

PRODUCIBILITY SYSTEM GUIDELINES

For **SUCCESSFUL** Companies

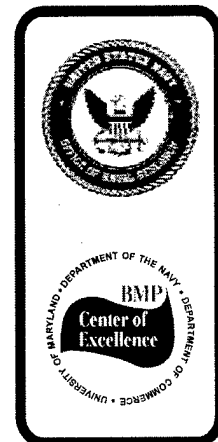

DISTRIBUTION STATEMENT A
Approved for Public Release
Distribution Unlimited

...The Five Steps To Success...

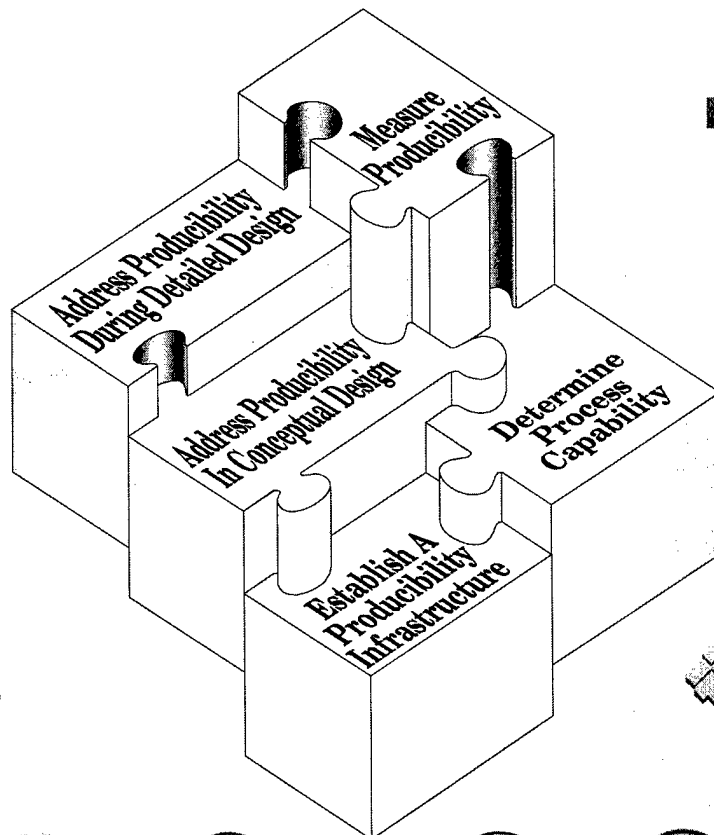

Raytheon

NIST



TRW

UTA
Engineering

BOEING

ITT Industries
Engineered for life



AQI 02-03-0510

DECEMBER 1999

**THE FIVE STEPS
TO SUCCESS**

**PRODUCIBILITY
SYSTEM GUIDELINES**

20011213 139

INTERNET DOCUMENT INFORMATION FORM

A. Report Title: **Producibility System Guidelines: The Five Steps to Success**

B. DATE Report Downloaded From the Internet: **12/12/01**

C. Report's Point of Contact: (Name, Organization, Address, Office Symbol, & Ph #):
**Best Manufacturing Practices
Center of Excellence
College Park, MD**

D. Currently Applicable Classification Level: **Unclassified**

E. Distribution Statement A: **Approved for Public Release**

F. The foregoing information was compiled and provided by:
DTIC-OCA, Initials: __VM__ Preparation Date 12/12/01

The foregoing information should exactly correspond to the Title, Report Number, and the Date on the accompanying report document. If there are mismatches, or other questions, contact the above OCA Representative for resolution.

PREFACE



Today, industry and government focus significant engineering and management attention on making goods more producible. Facing increased pressure to reduce outlays, many companies, organizations, and enterprises recognize that addressing producibility early, as part of the design process, is the most effective way to reduce costs and improve the quality of manufactured products. This guidelines document brings together concepts, techniques, and tools into a single explanation of what constitutes a successful producibility system, how to establish one, execute it, and measure its results.

The Best Manufacturing Practices program's Producibility Task Force (PTF), selected from industry, government, and academic experts, gathered for the first time in the spring of 1997 to develop a common-sense approach to producibility.

The PTF determined there are five basic steps in building and maintaining a successful producibility system. These five steps represent the criteria from numerous successful producibility programs and provide the basis for this document. By bringing together the basic elements of producibility, the PTF guidelines present a clear, easily understood picture of what any enterprise, regardless of size, can do to make its products more producible.

This guidelines document has significance for the future of U.S. manufacturing industries. We are now competing on a global scale where high quality is demanded and low cost is expected. The recognition of the importance of addressing producibility early in the product development cycle and the employment of an effective producibility system from design through production are critical to maintaining a vibrant position in the world marketplace.

Ernie Renner
Director,
Best Manufacturing Practices Program and
Center of Excellence

Contents

Producibility Guidelines Document

Preface

Introduction

I.1. Background	1
I.2. Purpose	2
I.3. Overview of Producibility	3
I.4. Producibility Tools and Techniques	6
I.5. Document Format	7
I.6. Recommendations for Use	8
I.7. Disclaimer	10
I.8. Summary	10

Section 1

<i>Step 1 - ESTABLISH A PRODUCIBILITY INFRASTRUCTURE.</i>	11
1.1. Recognize the Need for Management Commitment	12
1.2. Organize for Producibility	14
1.3. Implement a Risk Management Program	16
1.4. Incorporate Producibility into New Product Introduction Strategy	17
1.5. Employ Producibility Design Guidelines	18
1.6. Instill a Commercial Best Practices Philosophy	19

Section 2

<i>Step 2 - DETERMINE PROCESS CAPABILITY.</i>	23
2.1. Understand Current Process Capabilities (Company and Supplier)	24
2.2. Predict Future Process Capabilities	27

Section 3

<i>Step 3 - ADDRESS PRODUCIBILITY DURING CONCEPTUAL DESIGN.</i>	31
3.1. Identify Product Goals	32
3.2. Identify Key Characteristics	34
3.3. Perform Trade Studies on Alternative Product and Process Designs	35
3.4. Develop a Manufacturing Plan	36
3.5. Perform a Complexity Analysis	37

Contents (Continued)

Producibility Guidelines Document

Section 4

Step 4 - ADDRESS PRODUCIBILITY DURING DETAILED DESIGN.	39
4.1. Conduct Producibility Engineering Review	39
4.2. Error-Proof the Design	41
4.3. Optimize Manufacturing	42

Section 5

Step 5 - MEASURE PRODUCIBILITY.	45
5.1. Measure Processes	47
5.2. Measure Products	49
5.3. Measure Producibility System	50

Conclusion	53
-------------------------	----

Appendix A - Acronyms	A-1
Appendix B - Glossary of Producibility Terms	B-1
Appendix C - Bibliography	C-1
Appendix D - Case Studies	D-1
Appendix E - Industry Applications and Techniques	E-1
E.1. Customer Satisfaction Through Design for Manufacture / Assembly and Six Sigma Analysis	E-1
E.2. Producibility Design-to Requirements: Helping Enhance Product Definition	E-9
E.3. Producibility Program Implementation Checklist	E-18
Appendix F - Tools and Techniques	F-1
F.1. Tools and Techniques	F-1
F.1.1 Benchmarking	F-3
F.1.2 Cost Tools	F-4
F.1.3 Database Management Systems	F-5
F.1.4 Decision Support Tools	F-7
F.1.5 Design for Manufacture / Assembly	F-8
F.1.6 Design of Experiments	F-9
F.1.7 Failure Mode and Effects Analysis	F-10

Contents (Continued)

Producibility Guidelines Document

F1.8.	Integrated Product and Process Development	F-12
F1.9.	Integrated Product Team	F-13
F1.10.	Knowledge-Based Systems	F-14
F1.11.	Manufacturing Planning Tools	F-15
F1.12.	Manufacturing Simulations	F-17
F1.13.	Modeling and Simulation	F-17
F1.14.	Producibility Assessment Worksheet	F-18
F1.15.	Prototyping	F-19
F1.16.	Quality Function Deployment	F-21
F1.17.	Rapid Prototyping	F-23
F1.18.	Risk Management Tools	F-24
F1.19.	Root Cause Analysis	F-25
F1.20.	Six Sigma	F-26
F1.21.	Statistical Process Control	F-27
F1.22.	Statistical Quality Control	F-29
F1.23.	Tolerance Analysis	F-30
F2.	Producibility Software	F-31
F2.1.	Design for Assembly	F-31
F2.2.	Statistical Process Control and Statistical Quality Control	F-32
F2.3.	Simulation	F-32
F2.4.	Tolerance Analysis	F-32
F2.5.	Miscellaneous Producibility Software	F-32

Figures

Producibility Guidelines Document

I.1	Addressing Producibility Early is the Key to Success	1
I.2	The Five Steps	3
I.3	The Five Producibility Steps and Elements	4
I.4	The Five Steps of Producibility	4
I.5	Product Phase Implementation of Producibility Elements	5
I.6	Producibility Tools and Techniques	6
I.7	Producibility Maturity	8
I.8	Implementation of Producibility Elements	9
I.9	Producibility is Everybody's Business	10

1.1	The Five Producibility Steps	12
1.2	Key Points of Step 1 - Establish a Producibility Infrastructure	13
1.3	Staffing Profile: IPT Approach vs. Traditional Approach	15

2.1	The Five Producibility Steps	24
2.2	Key Points of Step 2 - Determine Process Capability	24
2.3	Tools and Techniques for Understanding Current Process Capabilities	26
2.4	Moore's Law for Intel CPUs	28
2.5	Tools and Techniques for Predicting Future Process Capabilities	28

3.1	The Five Producibility Steps	32
3.2	Key Points of Step 3 - Address Producibility During Conceptual Design	33
3.3	Tools and Techniques for Performing Trade Studies	36
3.4	Badge Holder: Ten Part Assembly vs. Single Part	37

4.1	The Five Producibility Steps	40
4.2	Key Points of Step 4 - Address Producibility During Detailed Design	41
4.3	Error-Proofed Bracket Design	42
4.4	Tools and Techniques for Optimizing Manufacturing	43

5.1	The Five Producibility Steps	46
5.2	Continuous Improvement in Producibility	47

Figures (Continued)

Producibility Guidelines Document

5.3	Key Points of Step 5 - Measure Producibility	48
5.4	Tools and Techniques for Measuring Processes	49
5.5	Tools and Techniques for Measuring Products	50
5.6	Tools and Techniques for Measuring Producibility Systems	51
<hr/>		
D.1	Case Studies vs. Producibility Elements	D-1
D.2	Risk Scoring Matrix	D-7
<hr/>		
E.1	Long Range Advanced Scout Surveillance System	E-1
E.2	GPSIS Cover Assembly	E-2
E.3	IPT Overall Process	E-3
E.4	Design Option 1	E-5
E.5	Design Option 2	E-5
E.6	Design Option 3	E-5
E.7	Design Option 4	E-6
E.8	Design Option 5	E-6
E.9	Design Option 6	E-6
E.10	Design Option 7	E-7
E.11	Concurrent Engineering Approaches	E-10
E.12	Lessons Learned and Design-To Requirements	E-12
E.13	Algorithms Define Producibility Design Characteristics	E-13
E.14	KPAT Augments Producibility Design Analysis	E-15
E.15	Concurrent Engineering Influence	E-16
E.16	Field Systems Benefit from Producibility and Supportability Engineering Improvements	E-17
E.17	Typical Design Review Checklist	E-21
<hr/>		
F.1	Producibility Tools and Techniques	F-1
F.2	Tools and Techniques vs. Producibility System	F-2
F.3	Example DFMEA	F-11
F.4	Universal PAW Example	F-20
F.5	QFD House of Quality	F-22

Figures (Continued)

Producibility Guidelines Document

F.6	Cause and Effect Diagram	F-25
F.7	Sigma	F-26
F.8	Histogram Example	F-28
F.9	Control Chart Example	F-28
F.10	Sample OC Curve	F-29
F.11	Producibility Software	F-33 - F-38

INTRODUCTION

I.1. Background

Dramatic changes in world competition have resulted in a major re-evaluation of how American industry develops and manufactures products. In the 1980s and the early to mid-1990s, there was a determined attempt to emulate Japanese manufacturing procedures. This led to the adoption of such concepts as Just-in-Time in which, theoretically, no one maintains inventory; each item needed at each step in the production and distribution chain arrives just in time and is exactly what is needed at that time. Total Quality Management (TQM) was another technique adopted. Based on the ideas of an American, W. Edwards Deming, and on earlier U.S. statistical quality control activities, TQM became the slogan for improvements in every aspect of the U.S. industrial environment. In 1990, the book, *The Machine That Changed The World*, focused attention on what the authors called "the Japanese auto industry's secret weapon" and on how and why lean manufacturing should be applied in U.S. industry in place of mass production. The application of these and many other techniques to enhance producibility is having a dramatic effect on U.S. industrial competitiveness.

Over this same period, the Department of Defense (DoD) began to recognize that the military services would be required to continue to produce state-of-the-art defense equipment, but that they needed to do so with significantly reduced funding. Today, the DoD is undergoing reform of the processes by which it acquires this equipment and is seeking to reduce the time it takes to develop and produce the equipment. It is attempting to adopt the best practices that have been developing in commercial industry. The DoD can no longer rely on mass production processes because it now purchases most items in only limited quantities. There is a major attempt to procure commercially available equipment whenever possible and to adopt commercial technology for military use. Of particular concern to the DoD is the need to service, support, and upgrade equipment over increasingly long product lifetimes. New equipment must be designed to accommodate rapid changes in technology and the resulting obsolescence of parts, especially in electronics.

In order to remain competitive and realize these objectives, both commercial and defense industries must continuously improve their ability to effectively and efficiently develop and manufacture products that will satisfy the customer. To achieve this in an environment in which technology is changing rapidly, it is impractical to delay consideration of manufacturing until after a product concept has been developed. Indeed, the producibility of the product must be part of the development process and, in some cases, may drive that process. Many commercial and defense companies have recognized that enhancing producibility throughout the product design and development cycle is the most effective way to reduce costs and improve the quality of manufactured products.

The importance of addressing producibility early is illustrated in Figure I.1. As a product concept matures, the ability to influence producibility and resulting product costs decreases. In contrast to the typical producibility activity profile shown on the figure, the goal is to reduce producibility activity during the production phase of a product and increase that activity during the initial concept and design phases. The producibility guidelines presented in this document are focused on the consideration of manufacturing issues throughout the design and development of a product.

Approached in 1989 to help research information on producibility, the Navy's Best Manufacturing

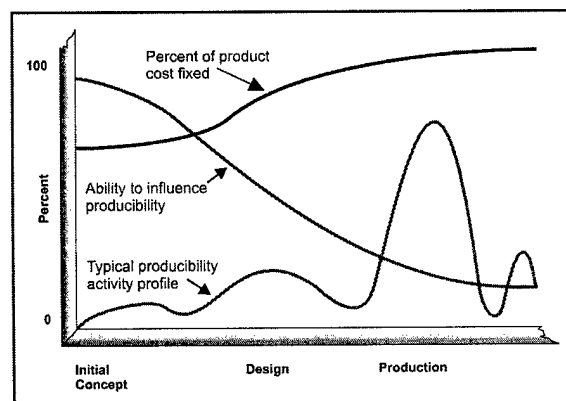

Figure I.1 - Addressing Producibility Early is the Key to Success

Practices (BMP) program produced two technical documents coauthored with experts from industry and government. "Producibility Measurement for DoD Contracts" was published in 1991, and "Producibility Measurement Guidelines" in 1993. Over the years, these documents have proven invaluable in helping many companies apply specific producibility measurement tools. Although they contained detailed descriptions of techniques and methodologies, the documents did not emphasize the specifics of integrating producibility into a total design and manufacturing program. This need was at the heart of industry's 1997 request to the BMP program to update the earlier producibility guidelines to include a clear explanation of how best to establish and maintain a successful producibility system.

In response to the industry request, a Producibility Task Force (PTF) was formed. The PTF determined that a traditional, comprehensive, and complex approach had to give way to a simplified and more concise, common-sense perspective. This new guidelines document had to define, in a straightforward manner, the steps and techniques required to build a successful producibility system. These guidelines are based on PTF deliberations and on each of the members' personal experiences with improving producibility.

The Producibility Task Force was comprised of representatives from the following industry, government, and academic institutions:

Robert Barazotto, University of Maryland
Michael Barbieri, Lockheed Martin Tactical Aircraft Systems
Richard Crispo, The Boeing Company
Richard H. Dewey, U.S. Army Chemical and Biological Defense Command
Erich Hausner, TRW
Robert Hawiszcak, Raytheon Systems Company
Jerry Knoski, Raytheon Systems Company
Swee Leong, National Institute of Standards and Technology
Roger Lindle, GE Aircraft Engines
Michael Malone, Lockheed Martin Tactical Aircraft Systems
Frank Mazza, Lockheed Martin Government Electronic Systems
Charles McLean, National Institute of Standards and Technology
Charles Minter, Best Manufacturing Practices Center of Excellence

Gregory Morano, ITT Aerospace/Communications
Jerry Norley, Motorola, Inc.
John Priest, University of Texas at Arlington
Ernie Renner, Best Manufacturing Practices Center of Excellence
Gene Wiggs, GE Aircraft Engines
Roy Witt, Best Manufacturing Practices Center of Excellence

The PTF thanks the following people for their contribution:

Art Froelich, Motorola, Inc.
Scott McLeod, Pioneer Manufacturing, Inc.
Terry Patterson, Raytheon Systems Company
Paul Zimmerman, Raytheon Systems Company

1.2. Purpose

Sometimes characterized as how to easily, repeatedly, and economically manufacture a product, producibility has stimulated the development and growth of numerous effective methodologies. Detailed information is available through technical documents, manuals, and software programs on topics ranging from Design for Manufacture / Assembly to the Six Sigma process of producibility measurement. Few documents, however, bring together concepts, techniques, and tools into a single explanation of what constitutes a successful producibility system, how to establish one, execute it, and measure results. That is the intent of these guidelines.

This guidelines document:

- **Presents** five basic steps to achieving producibility for any size organization;
- **Helps** those involved in designing and manufacturing a product to understand basic producibility concepts;
- **Serves** as a tool to assess an organization's current producibility efforts;
- **Assists** in identifying opportunities for improvement of an organization's producibility system;
- **Provides** information on what might be considered best-in-class in a producibility system; and
- Should be **integrated** into learning environments such as company training centers and the engineering curricula of technical colleges.

1.3. Overview of Producibility

In its deliberations, the PTF concluded that a single definition of producibility had to be understood and agreed to by all participants. Broadening the previous definition of producibility and defining what a producibility system included was of principal importance. The PTF agreed with the definition from the 1993 guidelines document that defined producibility as: "the relative ease by which a product can be manufactured." However, the PTF augmented that definition to include the fact that: "relative ease is measured in yield, cycle times, and the associated costs of options in product designs, manufacturing processes, production and support systems, and tooling." A producibility system, in the context of this document, is defined as "the integrated process and resources needed to successfully achieve producibility."

Producibility: The relative ease by which a product can be manufactured as measured in yield, cycle times, and the associated costs of options in product designs, manufacturing processes, production and support systems, and tooling.

Producibility System: The integrated process and resources needed to successfully achieve producibility.

In this document, the five basic steps to build and maintain a successful producibility system are presented. These five steps are based on criteria from numerous successful producibility programs and provide the foundation for this revised guidelines document. Although they may be examined independently, the five producibility steps are interdependent, each building on the preceding step.

- Step 1 - Establish a Producibility Infrastructure**
- Step 2 - Determine Process Capability**
- Step 3 - Address Producibility During Conceptual Design**
- Step 4 - Address Producibility During Detailed Design**
- Step 5 - Measure Producibility**

As shown in Figure I.3, each of the five steps includes the elements that are the building blocks of an effective producibility system. By bringing together these basic pieces of the puzzle, this new guidelines document presents a clear, easily under-

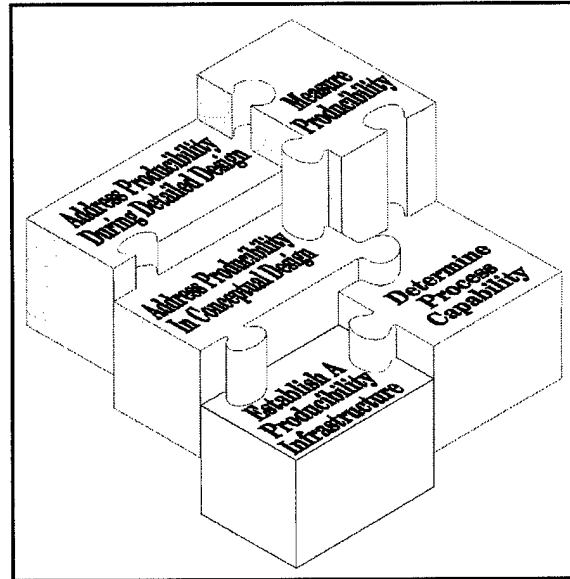

Figure I.2 - The Five Steps

stood picture of what any company, organization, or enterprise, regardless of size, can do to make its products more producible.

The interrelationship of the five producibility steps is shown in Figure I.4. Also shown on this figure is the notional product development cycle within a typical manufacturing enterprise, which begins with the preliminary conceptualization of a product and continues through the after-delivery service and support of that product. The five producibility steps are the numbered items on this figure. The block diagram and the phases of the process (Initial Concept, Preliminary Design, Detailed Design, and Production) represent the flow of product development in a typical company. Of importance is the understanding that the establishment of a producibility infrastructure in the enterprise (Step 1), the determination of its manufacturing process capabilities (Step 2), and its dedication to measurement of all aspects of product and process (Step 5) are areas that are universal to all products. They are not items that begin at a given product conceptualization nor end when production of a given product is complete. They form the inherent qualities that are the keys to improving producibility.

In contrast, producibility actions during conceptual design (Step 3) and detailed design (Step 4) are focused on a specific product. Some elements of these steps begin before the related phase of development and some extend beyond that phase. For example, the development of a manufacturing plan normally be-

- Step 1 - Establish a Producibility Infrastructure**
- 1.1 Recognize the Need for Management Commitment
 - 1.2 Organize for Producibility
 - 1.3 Implement a Risk Management Program
 - 1.4 Incorporate Producibility into New Product Introduction Strategy
 - 1.5 Employ Producibility Design Guidelines
 - 1.6 Instill a Commercial Best Practices Philosophy
- Step 2 - Determine Process Capability**
- 2.1 Understand Current Process Capabilities (Company and Supplier)
 - 2.2 Predict Future Process Capabilities
- Step 3 - Address Producibility During Conceptual Design**
- 3.1 Identify Product Goals
 - 3.2 Identify Key Characteristics
 - 3.3 Perform Trade Studies on Alternative Product and Process Designs
 - 3.4 Develop a Manufacturing Plan
 - 3.5 Perform a Complexity Analysis
- Step 4 - Address Producibility During Detailed Design**
- 4.1 Conduct Producibility Engineering Review
 - 4.2 Error-Proof the Design
 - 4.3 Optimize Manufacturing
- Step 5 - Measure Producibility**
- 5.1 Measure Processes
 - 5.2 Measure Products
 - 5.3 Measure Producibility System

Figure I.3 - The Five Producibility Steps and Elements

gins toward the end of the preliminary design phase and extends beyond the detailed design phase. In preliminary design, the plan focuses on long lead needs including capital for equipment. During detailed design, the plan becomes a specific formula for

production. In the production phase, the plan is modified, as appropriate, to account for lessons learned during initial manufacturing. In this document, the description of an element has been placed in a step based on what appears to be a natural place to discuss the item. Hence, the discussion of the manufacturing plan is included in Section 3.4 as part of Step 3, Address Producibility During Conceptual Design.

The producibility system elements arrayed against the phases of the notional product development cycle of Figure I.4 are presented in the matrix shown in Figure I.5. This matrix illustrates the producibility system elements that are critical for the design, development, and production of a single product. The "X"s on the figure denote the product phase in which the element should first be implemented. The dots on the figure indicate the other phases in which implementation of the element continues. Each element is described in detail in the remaining sections of this guidelines document. As indicated previously, many of these elements span a number of the phases. For example, all the elements of Steps 1, 2, and 5 impact all products of the enterprise and hence have broader influence on the entire organization than is evident from this matrix. It should be noted that this document is focused on the producibility elements and steps that lead to efficient and affordable manufacturing and not on the tools and techniques used in production.

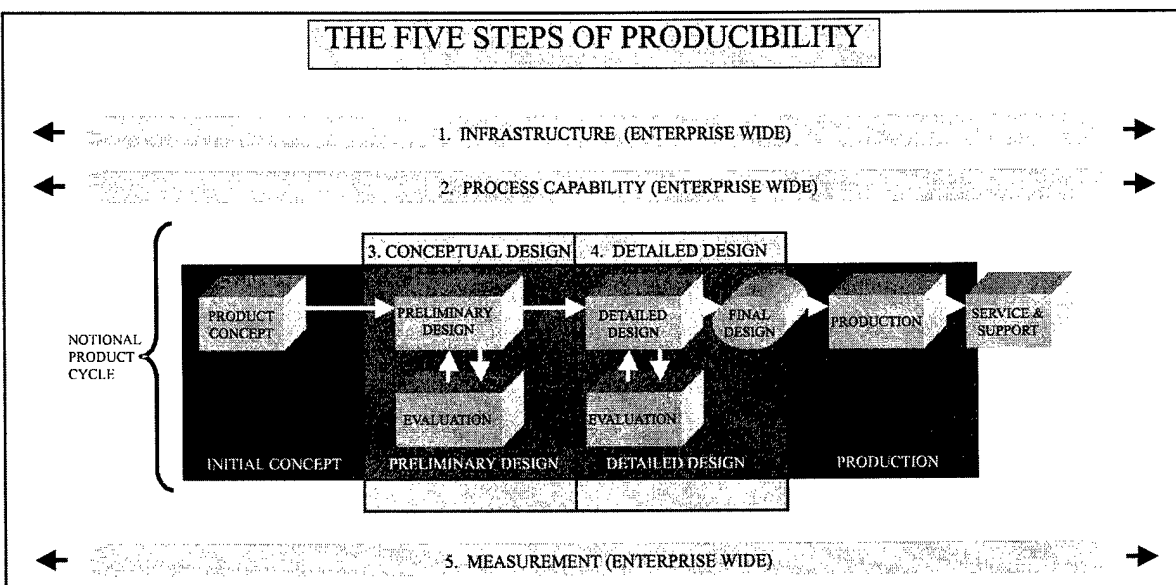

Figure I.4 - The Five Steps of Producibility

The five producibility steps and the producibility system elements are provided as a guide. It is not the intent to rigidly dictate what should be done and when, but rather to expose the reader to an overview of the key elements of the steps to improving producibility. Many of the elements can be implemented without implementing other elements. It is also important to note that although many of the key actions to achieve enhanced producibility are covered

in this document, it is impossible to ensure completeness in this rapidly changing field. In fact, the subject of producibility is continuously changing as more and more companies, organizations, and enterprises apply these techniques, modify them to suit their specific circumstances, and, in doing so, create new examples of best practices to achieve improved producibility.

Producibility Steps and Elements	Product Phase			
	Initial Concept	Preliminary Design	Detailed Design	Production
Step 1 - Establish a Producibility Infrastructure				
1.1 Recognize the Need for Management Commitment	X	●	●	●
1.2 Organize for Producibility	X	●	●	●
1.3 Implement a Risk Management Program	X	●	●	
1.4 Incorporate Producibility into New Product Introduction Strategy	X			
1.5 Employ Producibility Design Guidelines		X	●	
1.6 Instill a Commercial Best Practices Philosophy	X	●	●	●
Step 2 - Determine Process Capability				
2.1 Understand Current Process Capabilities (Company and Supplier)	X	●	●	●
2.2 Predict Future Process Capabilities		X	●	●
Step 3 - Address Producibility During Conceptual Design				
2.1 Identify Product Goals	X	●		
3.2 Identify Key Characteristics	X	●	●	
3.3 Perform Trade Studies on Alternative Product and Process Designs		X	●	
3.4 Develop a Manufacturing Plan		X	●	●
3.5 Perform a Complexity Analysis		X	●	
Step 4 - Address Producibility During Detailed Design				
4.1 Conduct Producibility Engineering Review			X	
4.2 Error-Proof the Design			X	
4.3 Optimize Manufacturing			X	●
Step 5 - Measure Producibility				
5.1 Measure Processes	X	●	●	●
5.2 Measure Products				X
5.3 Measure Producibility System				X
X - denotes the phase in which implementation of the producibility element begins ● - denotes continuing implementation of the producibility element				

Figure I.5 - Product Phase Implementation of Producibility Elements

I.4. Producibility Tools And Techniques

This document includes an overview of many of the current tools and techniques for achieving enhancements in producibility. Tools and techniques are indicated for many of the producibility elements and the document includes an appendix that provides a brief overview of each with references for obtaining additional information. The tools and techniques included are shown in Figure I.6.

In the not-too-distant past, it was deemed appropriate to compartmentalize industrial functions. This was a natural outgrowth of a management philosophy that encouraged a multi-tiered organizational structure with layers of middle management. Without today's computer and other communications technology, it was essential to provide intermediate management for the primary purpose of coordinating and controlling the activities of the enterprise. Hence,

Tools and Techniques
Benchmarking
Cost Tools
Database Management Systems
Decision Support Tools
Design for Manufacture / Assembly (DFMA)
Design of Experiments (DOE)
Failure Mode & Effects Analysis (FMEA)
- Design Failure Mode & Effects Analysis (DFMEA)
- Process Failure Mode & Effects Analysis (PFMEA)
Integrated Product and Process Development (IPPD)
Integrated Product Team (IPT)
Knowledge-Based Systems
Manufacturing Planning Tools
Manufacturing Simulations
Modeling and Simulation
Producibility Assessment Worksheet (PAW)
Prototyping
Quality Function Deployment (QFD)
Rapid Prototyping
Risk Management Tools
Root Cause Analysis
Six Sigma
Statistical Process Control (SPC)
Statistical Quality Control (SQC)
Tolerance Analysis

Figure I.6 - Producibility Tools and Techniques

the manufacturing director might meet with the other company directors in engineering, design, test, et al, to communicate the needs and status of manufacturing efforts and to learn about the needs and status of the rest of the organization. In order to understand the needs of manufacturing and to communicate the needs of others, the manufacturing director met with the managers for each manufacturing area. Each of them met with their supervisors who likewise met with the actual workers. This multi-level, middle management structure of communication and control was replicated throughout each part of the organization. The resulting process was not conducive to cost-effective product development and manufacturing. It established barriers between the workers in each of the functions and discouraged interdepartmental communication.

In recent years, it has been recognized that there is a more efficient and effective process that can rapidly and economically deliver quality products. It is the straightforward idea that all the key contributors to the development of a product must regularly communicate from first concept through delivery and product support. Although the specific participants may vary depending on the product, these key contributors normally include representatives of engineering, design, manufacturing, test, sales, marketing, accounting, and legal who are working on the specific product. Participants also normally include representatives of the suppliers and vendors and, whenever possible, the customer. All participants work together as a team to ensure that all aspects of the enterprise and its support structure as well as its customers are represented as the product evolves. For this model, most of middle management is not needed for communication. The team is composed of the workers and working level supervisors for that product, not the managers.

This concept has been described in various terms and with various titles. One such widely accepted term is Integrated Product and Process Development (IPPD). It encompasses the notion that the processes for manufacturing the product must be considered and developed together with the design and development of the product. IPPD is an outgrowth of earlier integrated design practices such as concurrent engineering. For the purposes of this document, IPPD is meant to encompass all such techniques for integrating the manufacturing process development and maturation with the product development.

IPPD encourages the formation of an Integrated Product Team (IPT) which includes representatives of all the key functions of the enterprise and its

customers and suppliers. The team works together from initial product concept to delivery to the customer, including after-delivery support. The IPT ensures that tools for controlling processes and for understanding the causes for, and solutions to, unacceptable product and process variability are implemented. The IPT must have the primary responsibility for implementing all essential elements of producibility during design, development, production, and support.

Throughout this document, emphasis is placed on including the customer as a member of the IPT. However, it is recognized that in some industries and for some products, customer participation on an IPT may not be appropriate or even possible. In those cases, the voice of the customer is still essential. This can be accommodated through participation on the IPT of a representative of marketing who may use customer contacts, trade information, and focus groups to assess customer desires and reactions.

1.5. Document Format

Each of the following sections of this document describes the producibility system elements of each of the five steps to improved producibility. At the beginning of each section, a table highlights the producibility elements for that step and a corresponding key point for each element. Each producibility element is then explained using the common format shown below to provide consistency across the many topics and to facilitate ease of comparison. Areas not applicable to a particular element will not appear. It is suggested that the document first be read completely before focusing on a specific topic of interest.

Producibility Element:

- **Description:** Brief description of the element.
- **Significance:** Explanation of how this element affects producibility.
- **Resource Requirements:** Explanation in each of the following as to what the company, organization, or enterprise may need to effectively apply the element.
 - **Staff:** What staff is needed to carry out this technique?
 - **Equipment:** What equipment is needed?
 - **Tools and Techniques:** Are techniques and software tools available to help?
 - **Training:** Will training be needed? What training is needed?

- **Implementation:** Explanation on how this element is best implemented

Appendices

While this guidelines document can be used as a stand-alone tool, there is substantial information located in the appendices. These appendices contain information compiled by the PTF to provide users valuable additional data to support and complement information contained in the text.

A standard list of acronyms is presented in Appendix A and a producibility glossary which includes definitions of terms as they relate to producibility is presented in Appendix B. This latter appendix is intended to provide an understanding of how many current manufacturing and design terms apply to the producibility field. An extensive bibliography of material used to develop this guidelines document can be found in Appendix C. This bibliography will help point users to specific sources for detailed producibility information.

The first three appendices are followed by a unique source of information – a compilation of best practices and processes either validated during BMP program surveys or submitted and verified by various companies throughout the U.S. Case histories, presented in Appendix D, highlight examples of the producibility elements in real world applications from many different companies.

This appendix is followed by Appendix E, Industry Applications and Techniques, which includes three industry examples that highlight some of the producibility system elements described in these guidelines. Appendix E.1 addresses the use of IPTs, Design for Manufacture, and Six Sigma to conduct design tradeoffs for the U.S. Army's Long Range Advanced Scout Surveillance System. Appendix E.2 presents a design-to-requirements process developed to enhance product definition while simultaneously reducing acquisition costs. This process addresses producibility from the very beginning of the product's life-cycle. Appendix E.3 is a producibility program implementation checklist that provides insight into the sequence of typical design reviews.

Summaries of the key tools and techniques presented in this document that are pertinent to producibility, including Design for Manufacture / Assembly, Six Sigma, Modeling and Simulation, and Quality Function Deployment (QFD), are presented in Appendix F. References to additional resources including available software, books, and technical papers are also included.

I.6. Recommendations for Use

These guidelines are aimed at all key personnel in a manufacturing enterprise – including top management. Specifically, product managers, project leaders, engineers, designers, and all personnel involved in managing and executing the development and production of a product should have an understanding of these guidelines.

The guidelines have applicability to organizations of every size and are appropriate for both defense and commercial entities. The guidelines present a clear, easily understood picture of what any company, organization, or enterprise can do to make its products more producible. Each of the five producibility steps contains the elements or techniques that help a company achieve or reach that step. While they may be examined independently, these elements and steps are interdependent, building on the preceding elements and steps. Therefore, it is recommended that the entire document be read or scanned before attempting to apply any of the producibility elements.

To facilitate the understanding of the five producibility steps, the PTF developed a series of three matrices for an organization to self-assess its level of producibility development and its strategy for improvement. It is recommended that the readers apply these matrices to their own organization's capabilities to gain a better understanding of where to place their investment in developing and / or improving their producibility system.

The self-assessment is performed using the matrix shown in Figure I.7 which identifies the producibility maturity of the organization. In this matrix, levels of proficiency, defined as “New to the Process,” “Moving up the Curve,” and “Fully Versed in Producibility,” can be measured against a set of criteria. For example, an organization would be considered “New to the Process” in the Organizational Structure criteria if it

does not use Integrated Product Teams. Similarly, an organization would be considered “Fully Versed in the Process” in the Supplier Relationships criteria if it involves its suppliers in the development and production of a product throughout the product development and production cycle.

Once a self-assessment is performed, two additional matrices serve as roadmaps to sequentially implement the various producibility activities discussed in this document. The matrix shown in Figure I.8 - Implementation of Producibility Elements, cross-references the producibility elements of the five basic steps against the levels of proficiency mentioned above. An organization that is “New to the Process” would probably achieve the maximum benefit by initially focusing its attention on the “Recognize the Need for Management Commitment,” “Organize for Producibility,” and “Implement a Risk Management Program” elements that affect the entire enterprise.

Figure I.5 - Product Phase Implementation of Producibility Elements, can be used to identify the proper timing for employing the producibility ele-

Criteria	New to Process	Moving Up the Curve	Fully Versed in Producibility
Management Commitment	General Interest	Demonstrated Understanding of Concepts	Institutionalized Support and Rewards System
Organizational Structure	Hierarchy (But May Have Small, Short Duration Teams)	Some Multi-Disciplinary Teams	Multi-Disciplinary Team Approach throughout Enterprise
Organizational Interactions	Over the Wall (Serial Process)	Periodic with Reviews	Continuous Interaction through Team Structure
Requirements Identification	Internal Assessment	Voice of the Customer Considered	Continuous Customer Involvement through QFD Process
Supplier Relationships	After-the-Fact	Critical Suppliers Phased into the Process	Upfront, Early Involvement on IPT
Risk Assessment	Product Performance Only	Partial Consideration of Processes	Full Consideration of Manufacturing / Assembly Processes
Design Procedures	Limited Documentation	On-line Database	On-Line Guidelines with Knowledge-Based Tool
Process Knowledge	Limited Documentation	On-line Database	On-Line Guidelines with Knowledge-Based Tool
Process Measurement and Control	Limited	SPC	Six Sigma
Product Metrics	Quality / Cost / Schedule	Variability Considerations	Six Sigma
Best Practices Philosophy	Not Open to Outside Solutions	Limited Use of Outside Solutions	Incorporation of Known Products and Processes (Benchmark)
Producibility Training	On-the-Job	Limited, Internal	Structured Educational Program (Internal and External)

Figure I.7 - Producibility Maturity

ments within an actual program. In this context, Figure I.5 highlights when elements should be addressed to achieve optimal producibility in the manufacture of a specific product. For example, "Identify Product Goals" should begin in the Initial Concept phase. "Error-Proof the Design" is normally started in the Detailed Design phase.

Use of all three of these matrices (Figures I.5, I.7, I.8) will highlight the producibility elements on which the organization should focus its efforts. They will identify areas for emphasis in the use of this document.

It should be recognized that although companies of all sizes can gain a competitive advantage through the implementation of the elements in the five

producibility steps, the degree of implementation may be dependent on the resources of the company. For example, software for the simulation of manufacturing processes often requires substantial resources including computer capability and trained and available personnel. Smaller enterprises may employ simpler modeling tools than larger companies due to more limited resources.

As noted previously, it is strongly recommended that the reader review the entire document before concentrating on specific elements to be implemented. An understanding of the interrelationship of the elements of the five steps is important for achieving success.

Producibility Steps and Elements	Maturity Level		
	New to Process	Moving Up the Curve	Fully Versed in Process
Step 1 - Establish a Producibility Infrastructure			
1.1 Recognize the Need for Management Commitment	X	X	X
1.2 Organize for Producibility	X	X	X
1.3 Implement a Risk Management Program	X	X	X
1.4 Incorporate Producibility into New Product Introduction Strategy			X
1.5 Employ Producibility Design Guidelines		X	X
1.6 Instill a Commercial Best Practices Philosophy			X
Step 2 - Determine Process Capability			
2.1 Understand Current Process Capabilities (Company and Supplier)	X	X	X
2.2 Predict Future Process Capabilities			X
Step 3 - Address Producibility During Conceptual Design			
3.1 Identify Product Goals	X	X	X
3.2 Identify Key Characteristics		X	X
3.3 Perform Trade Studies on Alternative Product and Process Designs		X	X
3.4 Develop a Manufacturing Plan		X	X
3.5 Perform a Complexity Analysis			X
Step 4 - Address Producibility During Detailed Design			
4.1 Conduct Producibility Engineering Review		X	X
4.2 Error-Proof the Design			X
4.3 Optimize Manufacturing			X
Step 5 - Measure Producibility			
5.1 Measure Processes		X	X
5.2 Measure Products		X	X
5.3 Measure Producibility System			X

Figure I.8 - Implementation of Producibility Elements

1.7. Disclaimer

The techniques for improving producibility are continuously evolving, and hence it is impossible to ensure completeness in any one document. These guidelines represent the PTF's judgment of the key considerations applicable to a wide range of manufacturing enterprises. The techniques and processes described herein are not meant to be rigidly applied. Taken together, they provide a useful, sufficiently complete guide to assist in improving the producibility of an organization.

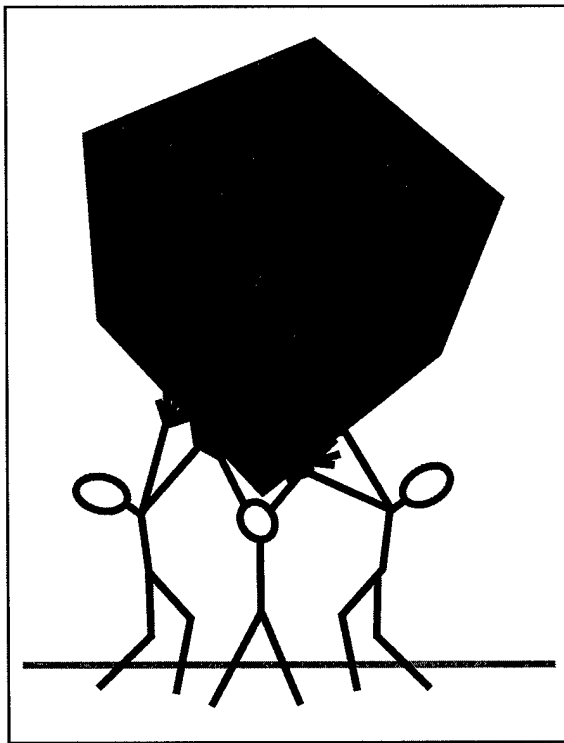

Figure I.9 - Producibility is Everybody's Business

1.8. Summary

Two facts remain unchanged from the 1993 "Producibility Measurement Guidelines." First, producibility is an evolutionary concept. Parts of this guidelines document will change as did parts of its predecessor. However, although new techniques or methodologies for achieving producibility may emerge, the elements presented in these guidelines should remain the basis for producibility enhancements.

Secondly, producibility is everybody's business. The historical view that producibility is someone else's problem is no longer acceptable. Producibility affects us all. Throughout industry, government, and society as a whole, no one – not design engineers, production personnel, management, government acquisition personnel, or taxpaying citizens – can ignore the necessity for manufacturing high quality products at an affordable price. In the end, we all pay for poor planning and inadequate designs.

Section 1

Step 1. ESTABLISH A PRODUCIBILITY INFRASTRUCTURE

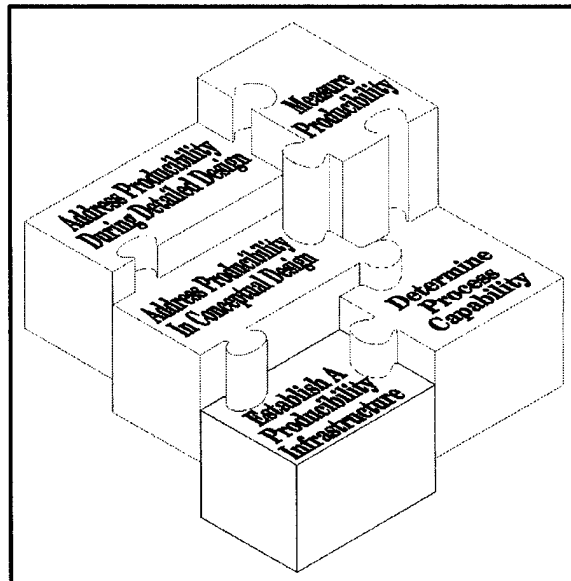

Figure 1.0 - Step 1 of the Five Steps

Establish A Producibility Infrastructure

The success of an enterprise's producibility system is directly related to the commitment of the enterprise to the producibility elements presented in this document and the ability of the organization to implement them effectively. As indicated in the Introduction, the notion of Integrated Product and Process Development (IPPD) and similar techniques encourages the involvement of all organizational components of the enterprise during the entire cycle of conceptualization, development, design, manufacturing, and support of a product. This philosophy of product development has emerged from the concept of concurrent engineering and is based on systems engineering principles. To implement this approach, an Integrated Product Team (IPT) is formed which has the responsibility and authority for the new product. Its membership should include suppliers, vendors, and, whenever possible, the customer.

In this step, six producibility elements are presented to guide the user in considering what is required to establish and support an effective producibility system. The relationship of this step,

Step 1 - Establish A Producibility Infrastructure, to the other four steps and to the notional product cycle for the development, production and support of a product in a typical manufacturing enterprise is illustrated in Figure 1.1. As shown, infrastructure encompasses the activities of the entire enterprise for all products. The elements discussed here set the tone for the organization. They are the backbone of the producibility system of the enterprise. The tools and techniques discussed within this step should be applied to all products.

The implementation of IPPD or a similar technique and the creation of empowered IPTs with total product responsibility appear to be simple and logical. The simplicity of the execution, however, depends on the ability of the enterprise to operate effectively in this manner. To do so requires a management that is fully committed to the process and a staff that understands the tools and techniques and is trained in their use. This management commitment should include an incentive recognition process that encourages the desired team behavior. The organization should be committed to the use of best manufacturing practices drawn from commercial industry whenever possible. It must understand that the keys to success are: delivering a product to the customer that meets or exceeds the customer's needs; that is easy to support and repair and preferably never needs either; that is delivered on time; and that costs no more than what the customer wants to pay. In other words, the entire enterprise must be focused on affordably meeting the customer's needs.

Since technology change is accelerating, it is imperative that the enterprise look for technical solutions for products and manufacturing processes that are easily upgradable. Of particular concern is the rapid change in electronics technology which can result in component obsolescence before the product is delivered to the customer. Product and process risk must be identified, assessed, and managed, and plans should be made for the insertion of new technology when available and if current technology becomes obsolete.

The six producibility elements that are part of establishing a producibility infrastructure and a corresponding key point for each are shown in Figure 1.2.

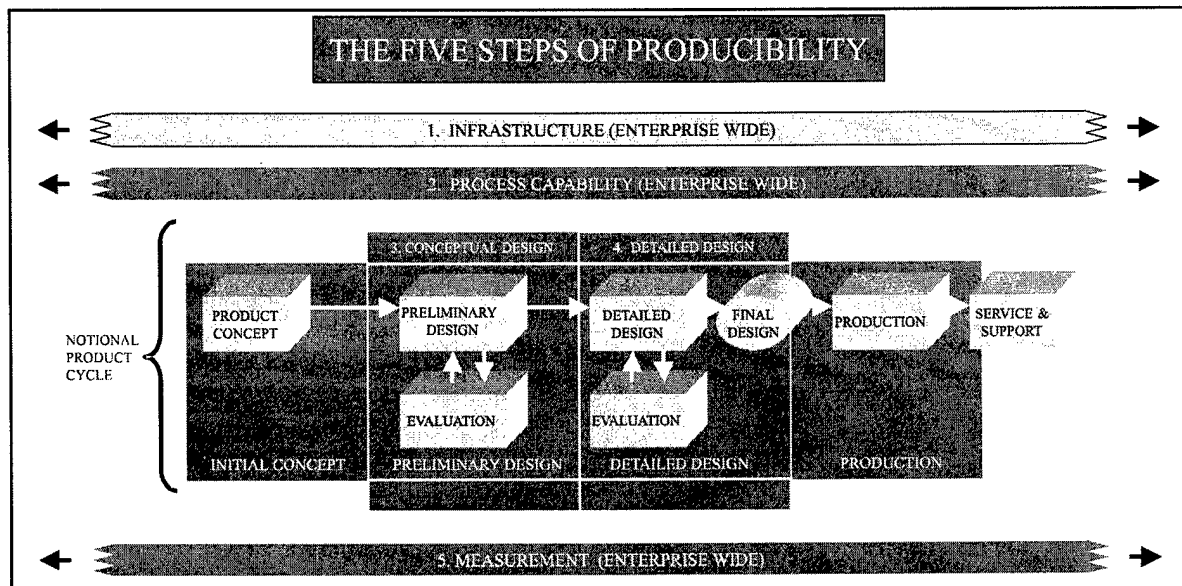

Figure 1.1 - The Five Producibility Steps

1.1. Recognize The Need For Management Commitment

Description

Enhancing producibility in an enterprise begins with the commitment of management. Implementation of a process such as IPPD, which integrates process development with the development and design of the product, and associated IPTs requires a clear indication that management encourages and supports the IPPD process and is willing to reward its staff for contributing to its successful implementation.

Management demonstrates its commitment to the producibility process through active engagement. Management must initiate the process, communicate expectations, set goals, empower teams, remain visible, provide managerial inputs, and commit to implementation of the results. Strong commitment and effective leadership generate success in a producibility system which, in turn, produces higher-quality, lower-cost designs for products that can be repeatedly manufactured with high yields. The commitment by management to provide for an effective producibility environment should permeate all infrastructure elements.

Management must also recognize that establishing a seamless, information-rich environment is a crucial part of the commitment. It is important that all members of the IPT have ready access to all relevant

information. Furthermore, it is essential that management is committed to understanding the capabilities of its organization and its processes. In this regard, measurement of all elements of product and process is critical. Management must foster an environment that requires measured data for decision making rather than the use of the resident expert. Finally, it must be clear to all that management believes that the ability to affordably manufacture and support the product is as important as product performance. The organization must maintain a focus on the customer – delivering what the customer wants, when it is wanted, and at the price the customer is willing to pay.

Case Studies 1 through 4 in Appendix D provide insight into the management commitment required to integrate producibility successfully into the product development process.

Significance

Historically, industry has spent significant resources on rework, scrap, and rejections. Much of this waste has resulted from a lack of communication among all the essential elements of the enterprise. A commitment by management to a producibility system as described in these guidelines will result in lower costs and enhance the organization's competitive posture.

Producibility System Element	Key Point
1.1 Recognize the Need for Management Commitment	Make producibility integral to the business. Train, empower, and encourage teams.
1.2 Organize for Producibility	Form multi-disciplinary Integrated Product Teams to facilitate communication.
1.3 Implement a Risk Management Program	Identify, assess, and attempt to mitigate production risk early in the design process.
1.4 Incorporate Producibility into New Product Introduction Strategy	Include producibility in every phase of the product development process.
1.5 Employ Producibility Design Guidelines	Apply best practices knowledge by maintaining and using design guidelines based on past experience.
1.6 Instill a Commercial Best Practices Philosophy	Identify and adopt commercial industry best practices. Whenever possible, use known solutions and processes.

Figure 1.2 - Key Points of Step 1 - Establish A Producibility Infrastructure

Resource Requirements

Staff: Commitment is required by all levels of management to achieve success. In particular, the company's senior staff and the leadership of the relevant IPTs must be dedicated to the achievement of an improved producibility system.

Tools and Techniques: There are many variations of the IPPD process – all with the same basic objective to integrate the design and development of the product with the development and maturation of the manufacturing processes. An overview of IPPD, including references for more information on this and related concepts, is presented in Appendix F.1.8.

Training: Training in the principles of IPPD and the use of IPTs to achieve the integration is essential.

Implementation

Effective communication is critical to integrate producibility into the product development process. In order to obtain the changes needed in the organization, a four-step process should be applied. First, information must be provided to all levels of the organization to build an awareness of producibility and the potential for improving the organization's products. Next, an understanding of producibility

skills, tools, and knowledge to implement the change must be acquired through education and training. Management must then commit to the change and communicate that commitment. Lastly, management must act to change the organization and its culture.

Management responsibilities for driving the cultural changes necessary for an effective producibility program include:

1. Making a long-term commitment to institutionalizing producibility as an integral part of doing business;
2. Ensuring that highly skilled people are available early in the design process to address producibility;
3. Educating and training employees in the producibility process, including producibility methods and tools;
4. Empowering, encouraging, and visibly supporting teams using producibility techniques;
5. Implementing the results of producibility efforts; and
6. Recognizing and rewarding producibility achievements.

For each product, initial and periodic senior management reviews with the IPT are critical to ensure up-front, mutual agreement on goals as well as continued support as the product develops. Senior management must provide the IPT with expectations and not specific direction on how to achieve the objective. In other words, management's role becomes one of enabling the IPT to arrive at an independent design solution. As noted in the next section, the organization must be capable of functioning in a manner very different from the traditional hierarchic organization.

1.2. Organize For Producibility

Description

In order to have an effective producibility system, an enterprise must be organized for producibility. Driven by a strong management commitment to affordably meet the needs of the customer, the organization must be capable of applying the principles of IPPD. To do so, the members of the organization must be adept at functioning in Integrated Product Teams (IPTs).

Sound business practice advocates a product development approach in which all necessary expertise is applied from the onset of the process. This expertise includes the knowledge and experience of the company as well as that of its customers and suppliers. In an effective producibility organization, an IPT concurrently develops the product and the process. Generally, IPT membership encompasses all organizational elements and includes representatives of the customers and the suppliers.

A major influence on any product is the customer. Early and continual involvement of the customer as a team member is an essential element of the IPT process. Active customer involvement ensures that customer requirements are well understood and that issues are resolved in real-time during the product evolution process. It should be noted that, in some industries and for some products, customer participation on an IPT may not be appropriate or even possible. In those cases, the voice of the customer must still be considered. This can be accommodated through participation on the IPT of a representative of marketing who may use customer contacts, trade information, and focus groups to assess customer desires and reactions.

Strategic partnerships and alliances with key suppliers is conducive to open communication. This free exchange of information enables rapid identification

of supplier producibility constraints such as: product costs, supplier availability and/or cost, and supplier capabilities. Representatives of key suppliers should be included on the IPT. This provides a direct link for the identification of alternatives to obviate any potential problems.

As a multi-disciplinary team, the IPT must be empowered and dedicated to achieving defined product and process goals. IPTs should have the primary responsibility for implementing all key elements of producibility during the entire product cycle. IPTs are effective at all stages of product development, from concept through design and into full production.

Case Studies 5 and 6, presented in Appendix D, provide some insight into the successful implementation of teams in a production operation.

Significance

Before IPTs became popular, an organization was usually hierarchically structured, which hindered the effective dissemination of vital information among and between participants. However, early involvement from a multi-disciplinary IPT has been proven to result in reduced design cycle time with fewer design changes downstream, and optimized personal performance levels through team dynamics. Through active customer involvement, requirements are better defined, understood, and negotiated. Designs facilitated through the use of an IPT generally result in reduced product costs, increased customer acceptance, and a better return on investment.

Resource Requirements

Staff: For an IPT to be fully functional and successful, it must have committed resources from the inception of the effort. Additionally, both customers and suppliers should participate on the IPT. The members of the IPT must have appropriate technical background in the areas they represent and should have knowledge of other disciplines. Staffing an IPT early, in the initial concept phase of a product development, is optimal. When compared to more traditional staffing approaches, early IPT staffing has resulted in a reduced staffing requirement during production, as shown in Figure 1.3.

Equipment: Networks should be established that allow key IPT members, including the customers and suppliers, to simultaneously view product development information. Team links through local

web sites or other forms of electronic data exchange improve the team's ability to process and efficiently use information.

Tools and Techniques: The concept of IPTs and similarly entitled teams has emerged as the key element for the implementation of IPPD. An overview of what these multi-disciplinary teams can achieve and how to structure and use them is discussed in Appendix F.1.9. An exceptionally useful tool for capturing and documenting customer inputs is the Quality Function Deployment (QFD) methodology (see Appendix F.1.16). QFD facilitates customer interaction in the product design process. Its objective is to methodically translate customer requirements into technical requirements during each phase of product development.

Training: Training in "people" and communication skills is required, with special emphasis on team dynamics for all IPT members. Team leaders might require additional training on how the functioning of an IPT differs from traditional management. It also may be beneficial for the IPT members to receive fundamental training in other disciplines to further their ability to integrate information within the IPT structure.

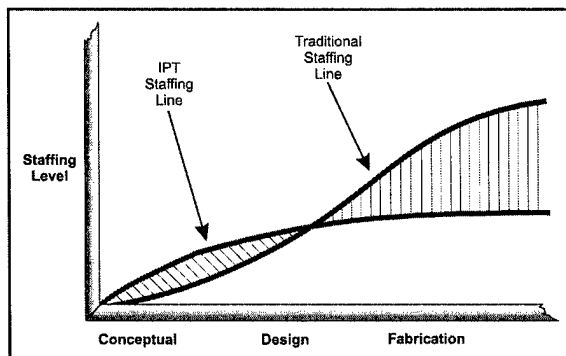

Figure 1.3 - Staffing Profile: IPT Approach vs. Traditional Approach

Implementation

Implementation of IPTs will vary among organizations since the approach must be aligned with the prevailing corporate culture. In organizations with a strong product management structure, a manager with clear lines of authority and accountability may drive IPT leadership. Conversely, in a functional organizational structure, IPT leadership may be

more distributed with overlapping control and accountability. Leadership may rotate among functional elements as the design evolves and matures. For example, Systems Engineering may lead the conceptual design phase while Manufacturing may drive production transition efforts. However, if the design is particularly challenging for Manufacturing, it may be appropriate for Manufacturing to lead the conceptual design team.

However instituted, effective implementation is dependent on choosing the right team. Three key considerations for the team are membership, size, and location. The IPT should typically consist of representatives with knowledge of key functional engineering, support engineering, and other stakeholder areas such as quality, manufacturing, procurement, customers, and suppliers.

There are several ways to structure the team – functionally (groups organized by their technical specialties), by product organization (a mix of disciplines), or as a matrix. A functional organization can accommodate a rapidly changing knowledge base. Conversely, a product organization can shorten the communication paths among team members and designate a responsible person to whom all team members report. A matrix (or hybrid) organization involves a person reporting to two different managers. For example, a person from one of the technical specialties reports to both the technical manager as well as to the product manager. This structure can be beneficial when resources must be shared across a number of product teams.

Determining optimal team size is not easy since it depends on many factors such as development scope, product complexity, product innovation, timing, and technology. However, between seven to ten members is an ideal size for a problem solving, decision making team. A team of this size can hold meetings of all types while still allowing for informality and spontaneity. A team of this size is, however, complex enough to require some structure to function properly.

While not essential, team co-location has many benefits, such as: exposure to other points of view, the ability to address communication problems among disciplines involved in systems development, and shorter development cycles which result in lower costs from fewer design changes and less rework.

The IPT leader is a facilitator, motivator, and consensus builder. The IPT leader has to encourage participation by all members of the team and not allow a dominant personality to take control. The members of the IPT must change their mind set from

a focus on a specific discipline to a focus on the product and its associated manufacturing processes. Each individual is expected to offer his or her expertise to the team as well as understand and respect the expertise available from other members of the team. They form the communication links to the balance of the organization.

1.3. Implement A Risk Management Program

Description

The development and production of any new product entails elements of risk. Risk has two components: (1) the probability or likelihood of an undesirable event occurring and (2) the effect or impact the occurrence of that event will have on the product. The goal of a risk management program is to anticipate risks and how they can be mitigated before they become problems.

Risk management entails actions to control risk. It includes risk planning, assessing risk areas, developing risk-handling options, monitoring risks to determine how they have changed, and documenting actions. The key to managing risk is to ensure that risk identification and assessment processes are in place and being followed from the onset of the product development. Such tools can assist in identification of potential risks early in the design process so that they can be assessed, tracked, and mitigated before they create significant problems. From the producibility perspective, risk reduction must focus on design and the transition to production, those areas that have the greatest impact on the successful manufacturing of the product.

The importance of risk management to producibility is highlighted in Case Studies 7, 8, and 9 in Appendix D.

Significance

Many product development efforts have failed because managers allowed the schedule to drive them into production with immature designs. They failed to identify risk early enough to preclude performance shortcomings or cost or schedule overruns.

Resource Requirements

Staff: The IPT is the instrument for risk management. All members of the team should view the management of risk as their own personal responsibility. Depending on product scope, some organizations utilize a risk facilitator (either full or part-

time) to work directly with IPTs to identify, track, and provide visibility to areas of risk so that managers and team leaders are continuously aware of the status of the risks and can make informed decisions on how to most effectively manage them.

Tools and Techniques: Risk Management Tools are available for assisting in assessing, analyzing and managing risk. Appendix F.1.18 includes a description of three tools that can address such issues as schedule, cost, and processing risk.

Training: The members of the IPT should be trained in risk assessment techniques and procedures including the need to follow a disciplined, repeatable process.

Implementation

Risk management activities begin at the outset of any product development effort and continue through all phases. Although the scope and method of implementation will vary with, among other things, product complexity, common threads of any risk reduction effort are:

- Risk identification: What process improvements are needed to ensure that producibility will be achieved? Do design analysis processes include a producibility assessment? Do trade study activities include producibility as a tradeoff criterion?
- Risk assessment: What consequences will result if identified areas of risk are not dealt with or are only partially addressed? Will the impact affect performance, cost, and/or schedule, and to what degree?
- Risk tracking: Is an unmitigated risk growing? By when must the risk be mitigated?
- Risk mitigation/reduction: What can be done to eliminate the source of the risk or reduce it to an acceptable level? Are funds available to develop and conduct the necessary risk mitigation efforts?

The following is an example of a risk management implementation strategy:

1. Issue statement and assessment of the risk or problem.
2. Identify the probability of success or the consequence of failure.
3. Consider the alternatives and the cost of each.

-
4. Recommend risk reduction / abatement method(s).
 5. Implement an impact statement (cost/schedule/technical).
 6. Identify the responsible organization and personnel.
 7. Establish criteria for closure of this risk activity.
 8. Highlight the decision points (flowcharts).
 9. Recommend backup developments and tests, including cost estimates.

It should be noted that since the implementation of such a strategy is both manpower and cost intensive, only the highest risk items should be assessed in this manner. Risk assessments should be tailored to fit the product and to satisfy customer requirements.

1.4. Incorporate Producibility Into New Product Introduction Strategy

Description

The infrastructure of the organization must have the capability to incorporate producibility into the decision process for the design and development of new products. Producibility must be in the forefront of management decisions to pursue new products, introduce product modifications, and support existing products. It is the management commitment described in 1.1 that sets the tone for the enterprise's emphasis on producibility in the new product introduction strategy.

Preliminary assessment of a potential product is the initial process of translating customer needs into initial product concepts. An IPPD approach should be implemented at this early stage. It is this attention to producibility at the earliest conceptual stage that has the largest influence on the eventual producibility and profitability of a product. Attention at this stage can also result in more rapid transition from product concept to final design. Of course, producibility is not the only consideration in decisions on initial product concepts. This is the time that market analyses, risk analyses, and organizational capability analyses are critical factors. A company must do everything it can to make sure that its products deliver an appropriate return-on-investment. The risks must be understood, and adequate resources must be allocated.

From a producibility perspective, this strategy should include consideration of insertion of newer technology after product introduction; obsolescence

of parts and sub-systems; the need for, and ease of, post production support for the product; and the use of commercial-off-the-shelf components and technologies in lieu of additional technology development. As noted in 1.6, use of commercial best practices in the introduction of new products includes an attempt to utilize only technology that is sufficiently mature. That is, to only use technology that has already been demonstrated in the environment in which it will be used and for which mature manufacturing processes have been demonstrated on the factory floor. Step 2 includes the important tools and techniques that should be used to understand current process capabilities and to predict future capabilities.

With a management commitment to producibility, the enterprise will be driven toward a new product strategy that incorporates producibility. The emphasis of the organization will be on developing the ability to include producibility aspects in every evaluation of potential new products. The relationship between this new corporate infrastructure and customers and key suppliers will permit more open communication of the opportunities and risks. This new infrastructure must be capable of supporting decision making processes that synergistically apply to all functional areas in the planning, manufacture, distribution, and implementation of new products and their subsequent impact on the entire organization.

Case Study 10 in Appendix D highlights the importance of incorporating producibility into an organization's new product introduction strategy.

Significance

The ability to forecast the producibility of a new product is important in determining that product's success and a company's continued profitability. Benefits include reduced transition time, reduced implementation costs, and maintainable schedule commitments.

Resource Requirements

Staff: Management must be committed to the execution of this strategy and must provide the resources and support required to implement it. Support for the understanding of process capabilities (see 2.1) and the identification of future process capabilities (see 2.2) is critical.

Training: The members of the IPT should be exposed to the precepts of this strategy and must be made aware of the enterprise's current and pro-

jected capabilities based on the activities presented in Step 2.

Implementation

The primary mechanism for incorporating producibility into a company's new product introduction strategy is the implementation of an IPPD process at the earliest stages of the product conceptualization. At every point in the development process, the maturity of manufacturing processes must be weighed against performance, cost, and other decision criteria. The process capabilities of the enterprise and its suppliers that are determined as part of Step 2 are critical for the effective implementation of this producibility system element. At the earliest stages of development, estimates of producibility are made based on similar technologies and products. These estimates become the basis for the producibility aspect of product evaluation. If a decision is made to proceed to product design, specific data is accumulated, whenever possible, to support further producibility assessments. This focus on producibility is critical to all phases of the product cycle. In particular, it must be a primary aspect of the trade studies conducted during the preliminary and detailed design phases (see 3.3 and 4.3). Some specifics include:

1. Dedicate funding for personnel, resources, and equipment to address producibility.
2. Include manufacturing personnel on product development teams from the start.
3. Identify manufacturing processes for new product concepts.
4. Assess process maturity and capability and use as a criteria for product concept selection.
5. As appropriate, establish manufacturing development projects to provide estimated development costs, estimated capital costs, schedules, and risk levels.
6. As appropriate, demonstrate process feasibility and identify equipment requirements, equipment costs, and risk levels.
7. Identify manufacturing procedures needed to provide a robust process.

1.5. Employ Producibility Design Guidelines

Description

In order to support the continued development of the enterprise in its quest to improve producibility,

the development of design guidelines is strongly recommended. Such guidelines contain the rules and procedures for improving producibility. They are based on expert knowledge and lessons learned from previous product development efforts. They form a unique knowledge base for the enterprise.

These guidelines may range from very simple recommendations to quantified requirements including specific methods and metrics. By setting metrics and measuring performance against those metrics, quantitative data that can highlight areas for design improvement and indicate areas of technical risk are developed. This quantitative information can support the development of additional guidelines as well as revisions to current guidelines.

The guidelines are a tool for both the experienced engineer and designer as well as the novice. They provide the parameters within which the design engineer should operate. However, it should not be a rigid rule book. The intent is to provide guidance and to avoid repeating known mistakes, not to hinder innovation and restrict resourceful improvements.

Design guidelines are applicable at every phase of the product development, from concept to detailed design. They are particularly important during concept development as they set the stage for the top-level requirements that flow down from conceptual and detailed design to the manufacturing processes for the final product.

Guidelines can also be used to incorporate changes in design parameters and tolerances to facilitate ease of production during a particular manufacturing process. Specific guidelines such as these must be individually developed and be based on specific capabilities. This assumes that the techniques of product simplification, standardization, and component selection have been incorporated (see 3.5 and 4.2). This is a systematic customizing effort aimed at maximizing production efficiency through product design. To support this activity, some organizations develop tailored, product-specific, design guidelines that are based on their general guidelines.

Case Studies 11 and 12 in Appendix D provide additional insight into the importance and use of design guidelines.

Significance

The establishment and maintenance of design guidelines provide the organization with the ability to avoid past mistakes and take advantage of the best knowledge available for addressing producibility. Design guidelines can be viewed as a risk mitigation action that assists in the considerations of

producibility in every aspect of development and design. (See the discussion on implementing a risk management program in 1.3.)

Resource Requirements

Staff: Developing design guidelines requires personnel capable of collecting lessons learned and translating the information to a specific set of design guidelines as applied to a functional specialty. This should be done by a corporate team, not a product specific team, that should be composed of experts in design, manufacturing, and customer support. This design guidelines team should function similarly to an IPT but should be focused on the entire enterprise and not on an individual product.

Tools and Techniques: A Database Management System can serve as a good repository of the lessons learned. An overview of database management systems is presented in Appendix F.1.3. Decision Support Tools are useful for extracting information from database systems, analyzing the data, and displaying the results in useful formats (Appendix F.1.4). Knowledge-Based Systems can provide a means for gathering, cataloging, and retrieving the knowledge of experts (Appendix F.1.10). In addition, the application of Root Cause Analysis (Appendix F.1.19) may be useful for identifying the causes of manufacturing problems to support the development of design guidelines.

Training: Some functional specialists may require training in the process of converting a known problem to its root cause and then developing specific guidelines. As necessary, training may be needed in the use of Database Management Systems, Decision Support Tools, Knowledge-Based Systems, and Root Cause Analysis.

Implementation

Design guidelines can come in many forms, from published checklists and standards to case-based reasoning incorporated in the designer's workstation. Whatever their form, producibility guidelines must be readily available and user friendly, and designers and engineers must know that they exist and must apply them. Management must be committed to the development and implementation of the guidelines and must provide the resources needed. Management should establish a corporate design guidelines team with the responsibility of collecting and maintaining the design information.

To develop and maintain these guidelines, time and resources must be allocated for collection, classification, continuous updates, and storage. Sources of information for developing guidelines include: product requirements, material properties, risk analyses, lessons learned from similar products, process variances, assembly process analysis, process and design failure mode and effects analyses (FMEAs) (Appendix F.1.7), design of experiments (DOE) (Appendix F.1.6), published checklists, experience, employee surveys, and consultants. Information gathered in 2.1 on current processing capability and from the measurement of processes and products during production (see 5.1 and 5.2) are essential elements of the guidelines. Instituting a discipline of post-mortem analysis following disruptions to the manufacturing process or test failures ensures that real-time lessons learned are collected for incorporation.

1.6. Instill A Commercial Best Practices Philosophy

Description

The best companies, the ones that are most highly respected for their innovative quality products and their profitability, continue to set the pace for improvements in producibility. They do so by instituting best practices such as IPPD and IPTs. They continuously benchmark best practices of others in related fields to look for evidence that they might have fallen behind.

The best companies tend to employ similar philosophies in the introduction of new products. With the exception of certain industries that will be addressed below, they will not proceed with the design and development of a product until they are certain that the technology is sufficiently mature. The approach is to identify technologies that have been used before for other purposes that can now be applied to the new product. The best solution to a technical need is to buy a component or part that provides a required function from someone else who already knows how to manufacture it. The new product then becomes a systems integration of known parts and components. The manufacturing processes are mature. The risks are reduced to what the enterprise knows best: the needs of its customers and the ability to find and assemble solutions to those needs. In some cases, new technology may be included in a product but only after it is sufficiently mature. Sufficient maturity is usually defined as technology that has been produced on a factory floor and implemented in a system in the same environment as the proposed product. In other

words, the technology has been demonstrated and applied. Additional effort required may be in maturing the production processes to improve yield and affordability, in integration of the technology in the proposed system, and in successful testing of the final design.

There is an exception to the introduction of "sufficiently mature" new technology. In the case of industries that are driven by rapid changes in technology and extreme competitive pressures, new product designs may begin long before technology demonstration is complete. The development of each new generation of computers is an example of such products. Because of the rapid pace of change and the extreme competition, even the "world-class" companies are forced to begin product designs long before the first prototype has been manufactured.

As stated in a U.S. General Accounting Office (GAO) report to the Subcommittee on Acquisition and Technology, Committee on Armed Services, U.S. Senate dated February 1998, "Commercial firms make a distinction between product and technology development. Product development entails the design and manufacture of a product . . . Technology development fosters technological advances for potential application to a product development." In comparing commercial best practices to DoD practices, the report notes that in both commercial and defense companies critical design reviews are held to assess the maturity of the design and its readiness for production. Engineering drawings calling out all the materials and details of the design are the usual measure. "Commercial companies typically have over 90 percent of these drawings available." DoD programs reviewed had between 33 percent and 60 percent available.

In an August 1996 report on best commercial quality assurance practices to the same committee, the GAO noted that there is a "striking difference between the way DoD's weapon system programs and world-class companies practice quality assurance." The latter make it part of their entire process from development to production, requiring: (1) communication between key players to achieve robust, producible designs before production begins, (2) the use of process controls to design products and control production processes, and (3) establishing long-term relationships with key suppliers. Commercial best practices incorporate the mind-set of designing for manufacturing using multi-disciplinary teams.

What is important is the need to understand what the best practices are and to apply that knowledge in

the design and development of products. Commercial practices are focused on customer-driven product performance specifications rather than on standards and operating principles that govern the processes used to design and manufacture the product. The DoD is supporting the increased use of commercial practices in the production of military equipment and weapon systems. Standards and specifications are being eliminated to every extent possible on new contracts to industry, and waivers are more easily granted on existing contracts. The use of commercial-off-the-shelf products and processes are encouraged. Responding to government initiatives addressing product affordability, defense corporations are seeking approaches to streamline their processes through the elimination of non-value-added activities.

Case Studies 13 through 16 in Appendix D provide insight into instilling a commercial best practices philosophy.

Significance

The use of commercial best practices can often result in significant cost savings and the rapid introduction of quality products.

Resource Requirements

Tools and Techniques: Benchmarking, which consists of the gathering of data on similar products and processes, is essential to understanding best practices. An overview of Benchmarking is presented in Appendix F.1.1. In addition, the Best Manufacturing Practices (BMP) program's database contains a substantial source of best practice information. The BMP database is available online on the Internet.

Implementation

First and foremost to the implementation of a commercial best practices philosophy is a management commitment to understanding the capabilities and limitations of its own enterprise and to benchmarking the best practices of related industry. From a producibility perspective, the key to an understanding of the capabilities of the enterprise is a determination of process capabilities as described in Step 2. The next step is to instill a corporate philosophy that encourages the use of existing solutions to design problems rather than the invention of new ways to solve the same problem. In other words, management must demonstrate that it is committed to the application of known technology and compo-

nents that have been previously applied by the enterprise or by others. Management must change the culture to overcome any not-invented-here considerations. Indeed, the practice of adopting only solutions that were invented elsewhere should be encouraged.

Finally, it is important to periodically benchmark competitors and partners to understand the current state of the art in the industry. Benchmarking

includes the gathering of data, the analysis of that data, the communication of the conclusion of the analysis in the form of goals and plans, and the implementation and monitoring of the planned improvements. Through information gathered from benchmarking conducted under partnering agreements with competitors and others, many enterprises continue to improve their manufacturing practices.

Section 2

Step 2. DETERMINE PROCESS CAPABILITY

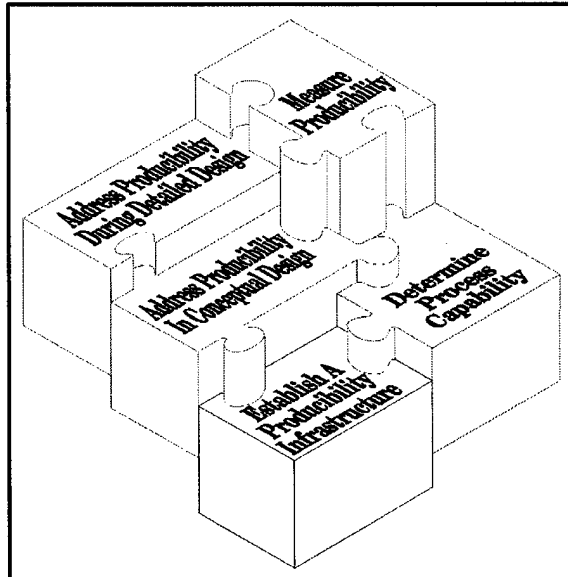

Figure 2.0 - Step 2 of the Five Steps

Determine Process Capability

A thorough knowledge of an enterprise's and its suppliers' process capabilities is critical to implementing a successful producibility system. Determining process capability is not a simple or a one-time effort. Process capability must be understood, measured, controlled, and documented, both in general and on a per product basis, and process capability information must be updated at periodic intervals. Information must be focused on what can be successfully manufactured accurately and repeatedly under various conditions and not what can be manufactured once under the best possible circumstances. It is this thorough understanding of process capabilities and the effective application of that knowledge to both current and future processing that is essential for achieving producibility.

In addition to fully understanding present capabilities, future process capabilities must be predicted to ensure that, as new or improved processes mature, they can be readily introduced into manufacturing with no detrimental effects to producibility. Predicting future capabilities is especially important in

markets like the electronics industry where product or process obsolescence forces the rapid development and use of new technology. Future process capabilities in this context means more than advanced, new processing techniques. It also means being cognizant of processes used by competitors or manufacturers in different industries and adapting those processes if, and when, it is appropriate.

The relationship of this step, Step 2 - Determine Process Capability, to the other four steps and to the notional process flow for the development, production, and support of a product in a typical manufacturing enterprise is illustrated in Figure 2.1. Shown as an enterprise-wide function, Step 2, with its goal of thorough understanding of process capabilities, is important both across the enterprise and with respect to a specific product line and a particular product.

Step 2 is closely allied with the two other enterprise-wide steps: Step 1 - Establish A Producibility Infrastructure and Step 5 - Measure Producibility. With regard to producibility infrastructure, process capabilities must be fully understood to accomplish the goals of Integrated Product and Process Development (IPPD), which encourages the development of manufacturing processes together with the design and development of the product (1.1). Process capability data and the producibility design guidelines (1.4) jointly focus on ensuring that designs are producible by incorporating process knowledge with specific design parameters. With respect to Step 5 - Measure Producibility, a complete understanding of process capabilities can only be accomplished through effective, repeated measurement and control of processes.

The producibility elements of Step 2 also figure prominently in Steps 3 and 4, as understanding process capabilities is paramount to the successful production of a particular product. A thorough knowledge of capabilities ensures that the trade studies performed on alternative product and process designs (3.3) are most effectively accomplished and that the manufacturing plan developed (3.4) enables the affordable production of a product which meets the customer's performance, cost, and schedule requirements.

In this step, two producibility elements address

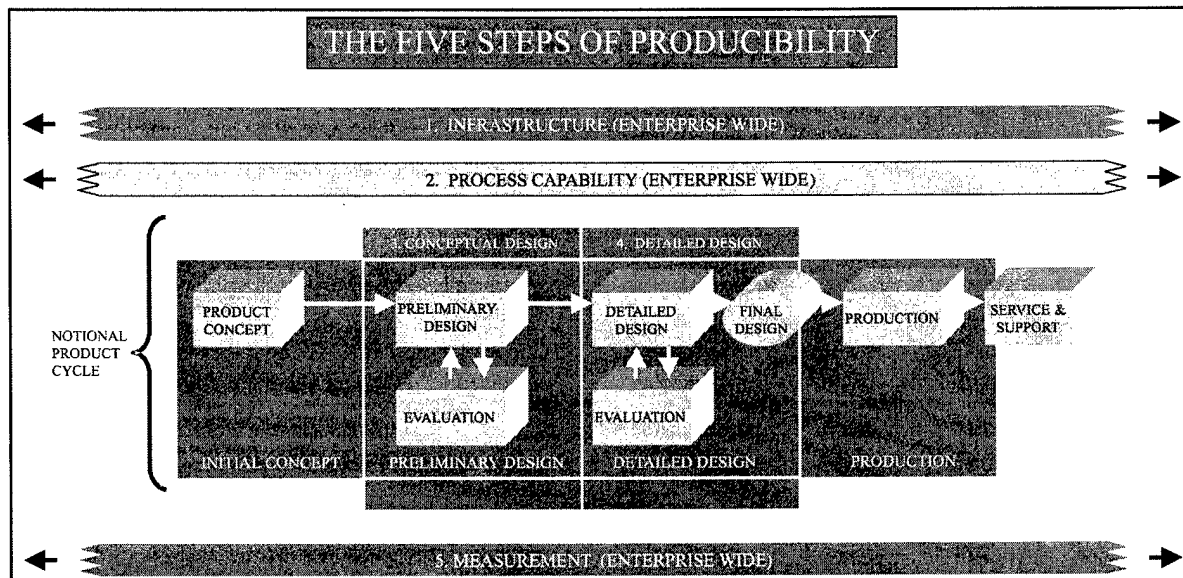

Figure 2.1 - The Five Producibility Steps

determining process capability. The first element, 2.1, describes the importance of understanding and capturing the company's and its suppliers' current capabilities and discusses some tools that aid in both process understanding and process measurement. The second element, 2.2, addresses the necessity of accurately predicting future capabilities and deals with issues such as obsolescence and technology insertion. These two elements and a corresponding key point for each are shown in Figure 2.2.

2.1. Understand Current Process Capabilities (Company And Supplier)

Description

Understanding current process capabilities means more than knowing which processes an organization

is capable of utilizing in manufacturing its products. A thorough knowledge of process capabilities is achieved only by effective process measurement, process control, and the application of resulting data to future processing. Data must be properly documented, and the documentation updated regularly. The organization must ensure that this process capability documentation is utilized in the design and processing of future products as well as in the optimization of the manufacturing sequence for current products. Management commitment to a thorough understanding of process capabilities and the effective application of that knowledge to both current and future processing is paramount to enhancing producibility.

Process capabilities must be determined for both the organization itself and for its key suppliers. In general, the depth of understanding required for the

Producibility System Element	Key Point
2.1 Understand Current Process Capabilities (Company and Supplier)	Measure and control processes for thorough understanding. Document knowledge in process capability guidelines and update guidelines routinely.
2.2 Predict Future Process Capabilities	Study new technologies for integration. Ensure that processes are sufficiently mature to use in production.

Figure 2.2 - Key Points of Step 2 - Determine Process Capability

organization's processes is far greater than that required for suppliers' capabilities. However, for highly complex components or subassemblies which require precise, difficult processing, an organization must ensure that its suppliers have a similar commitment to the requisite understanding and control of its respective processes.

It is tempting for an organization committed to a more complete understanding of its process capabilities to require that a similar level of knowledge be achieved for every process. This, however, is neither required nor economically prudent. Monitoring and tightly controlling every process is not crucial. One of the most important steps in determining process capabilities is performing a tradeoff analysis which identifies the level of understanding and control required for each process. This analysis should identify which processes must be fully understood, monitored, and controlled and which processes are perhaps less complex or less critical to the manufacture of product and therefore require a less complete understanding. Oftentimes, an organization's first cut at a tradeoff analysis might target complex and specialized processes. However, the complexity or specialization of a process does not necessarily determine its need for a more in-depth process understanding. An organization might utilize a very complex and specialized process in the manufacture of its products; however, the tolerance requirements of those products may be lax enough to enable less rigorous process monitoring and control. In general, any process which is critical to the organization's product lines and which requires the optimization of a number of process parameters must be more thoroughly understood and controlled than those less important processes. These critical processes might be those that enable an organization to be the supplier of choice for a certain product line or those that permit the company to compete more successfully against its competitors. They may be those considered by the company to be its niche or its core competency processes. Certainly, they must be those that, without effective process understanding and control, are responsible for or contribute to a product not meeting the customer's performance, cost, and schedule requirements.

From a risk management standpoint (1.3), an additional consideration in identifying the level of process capability understanding and control required is process maturity. A technology can be defined as mature if it has been demonstrated on the factory floor and successfully used to manufacture a similar product in the past. Processes that are not

mature usually require additional studies and statistical analyses to ensure that the capability is fully understood and defined prior to its use in the production of a product.

The understanding of process capabilities must be both general and product specific. Although a large number of different products might require the use of a particular process during their manufacture, the level of understanding and control of the process will likely vary on a product-by-product basis as well. It is precisely this reason that determining process capabilities is both an enterprise-wide and a product-specific step in achieving producibility throughout the organization.

Process capability documentation, or guidelines, defines the manufacturing capabilities and delineates the limits and rules associated with each. This documentation can be in the form of guideline handbooks, a process capability library, a database management system, or a knowledge-based software application. Regardless of the form of the guidelines, process capability data must be integrated into the organization's design and engineering procedures and utilized by product IPTs in the development of their products.

Process capability guidelines should contain information on process capabilities and constraints (i.e., products, design features, tolerances, materials); optimum process parameters; and data on overall manufacturing capability such as resource availability (i.e., parts, materials, and production systems) and production capacity (low versus high volume as well as part and volume mix).

Determining process capability must be looked at as a continuous and not a one-time effort. The guidelines must be updated regularly to benefit the producibility of future products. This is particularly important with the introduction of a new product line. Taking the lessons learned from new product manufacture and feeding the process parameters and constraints into process capability documentation ensure that the organization is most effective in producing similar products in the future. Additionally, the organization might find that processes developed or optimized for a new product might successfully be substituted in the manufacture of older products with resultant increases in product performance, decreases in product cost, or reductions in product schedule.

Case Studies 17 through 21, presented in Appendix D, provide additional insight into the importance of determining process capabilities.

Significance

Process capability understanding aids in ensuring compatibility between design and manufacturing processes and in making critical make / buy decisions. Without adequate knowledge of both internal and supplier capabilities, a company cannot make informed decisions regarding product manufacture, which oftentimes results in products not meeting quality, cost, or schedule requirements.

Resource Requirements

Staff: A corporate process capabilities team, designated by corporate management, coordinates the process capabilities effort across the organization. The team functions similarly to an IPT but is focused on determining process capabilities across the entire enterprise and not solely for a specific product. Experts from design, materials, manufacturing, and quality organizations are required.

Tools and Techniques: There are a number of tools and techniques helpful in determining process capabilities. Techniques that aid in process understanding include Modeling and Simulation (Process), Prototyping (Process), Design of Experiments (DOE) or Taguchi studies, and Process Failure Mode and Effects Analysis (PFMEA). Techniques for process measurement, verification of process capability data, and/or process control include Six Sigma and Statistical Process Control (SPC). Benchmarking is a useful technique for process comparison and evaluation. Depending on the chosen method for process capability documentation, required tools might include web-based software, a Database Management System, or a Knowledge-Based System. Decision Support Tools help in extracting information, analyzing data, and displaying the results in a useful format. The tools and techniques, as well as the appendices where additional information on these tools can be found, are listed in Figure 2.3.

Training: Many of the tools and techniques commonly used to thoroughly determine process capabilities are not self-explanatory, and, although not required, training on the effective use of these tools and techniques is recommended. Training on Six Sigma and SPC is particularly encouraged.

Implementation

Implementation begins with a corporate commitment to producibility. Corporate management should

Tools and Techniques	Appendix
• Benchmarking	F.1.1
• Database Management Systems	F.1.3
• Decision Support Tools	F.1.4
• Design of Experiments (DOE)	F.1.6
• Knowledge-Based Systems	F.1.10
• Modeling and Simulation	F.1.12
• Process Failure Mode & Effects Analysis (PFMEA)	F.1.7
• Prototyping	F.1.14
• Six Sigma	F.1.20
• Statistical Process Control (SPC)	F.1.21

Figure 2.3 - Tools and Techniques for Understanding Current Process Capabilities

establish a corporate process capabilities team with the responsibility of determining process capability. This corporate team defines the types of process capability information necessary and ensures its collection, documentation, and update.

In addition, corporate management should encourage the respective product IPTs to make use of process capability information in their product and process development. Each IPT is responsible for identifying the level of process understanding and control required to ensure product producibility and for making this information available to the corporate process capabilities team.

The incorporation of this product-specific process capability information back into the guidelines is the responsibility of the corporate process capabilities team. It is clear that effective coordination between the corporate process capabilities team and the product-specific IPTs is required.

Ten general steps used in determining internal and supplier process capabilities are:

1. Establish a corporate process capabilities team to coordinate process capability information. Identify the process experts required.
2. Identify processes for which data will be collected. Identify depth of knowledge generally required for each capability. For those process capabilities for which the depth of knowledge required varies on a per product basis, coordinate with product-specific IPTs.
3. Identify suppliers for which capability data is required. Identify depth of knowledge required for supplier capabilities.
4. Determine the method of process capability documentation to be used, as well as its distribution and access requirements.

Determine documentation update procedure and update cycle. Select documentation support tools.

5. Develop the format and forms for data collection.
6. Collect data. If necessary, conduct studies or analysis (such as DOE, PFMEA, prototyping, or modeling and simulation) to more fully understand process capability. Identify optimum processing parameters. Highlight process inconsistencies and determine their cause. Utilize statistical analyses to assess process capabilities.
7. Organize and document data in process capability guidelines.
8. Integrate the use of process capability guidelines in the company's design guidelines (1.5) and engineering procedures. Educate users on capability data.
9. Continuously verify and monitor data (through methods such as SPC or Six Sigma). Ensure that process capabilities do not vary over time through the use of SPC tracking mechanisms.
10. Periodically review and update process capability guidelines. Ensure that data being collected matches data required. Update list of suppliers for which data is required.

2.2. Predict Future Process Capabilities

Description

Just as it is critical to have a thorough understanding of current process capabilities, it is also very important to predict future process capabilities and develop or incorporate those that are advantageous to the organization. There are many reasons – external and internal – why advances in technology must be followed and applicable technology incorporated into an enterprise's process capabilities. External reasons may include increasing competition in the marketplace and customers who are demanding that their products be produced more affordably and more quickly. They may include customer expectations that new technology be used or a change in design that necessitates the use of a new process. Internal reasons may be driven by the product and include design changes or a need to produce the part more accurately to reduce rework and scrap. Internal process-related reasons may be due to a conflict in shop floor planning and scheduling (such as too

many products requiring the same equipment) or process obsolescence (resulting from environmental regulations, older equipment failure and the decision to substitute a new process rather than replacing the equipment, or the fast pace of electronics development). Whatever the impetus, organizations must make keeping abreast of beneficial technology and developing or maturing it a priority.

A future process capability can either be developed internally from its inception or developed externally and then incorporated and matured internally prior to its use in manufacturing. Regardless of the source of the new technology, it is essential that producibility engineers ensure that, prior to its production use, the process is mature and well understood (as discussed in Step 2.1), compatible with existing production processes, and beneficial from a producibility standpoint. Process maturity and a thorough understanding of the capability prior to use in production are critical.

For each product, consideration of new technology should begin in the earliest phases of product development, and opportunities for the incorporation of new technology should be periodically assessed throughout the transition from design to production as well as throughout production. This assessment should focus on the adaptability and maturity of the technology and its potential to be readily introduced into the manufacturing cycle, with no detrimental effects to producibility. In the design of a particular product, technology insertion should be considered as part of the trade studies conducted by the product-specific IPT (3.3).

Technology insertion is a means of dealing with the rapidly growing problems posed by obsolescence or by Diminishing Manufacturing Sources (DMS), which can be defined as the loss or impending loss of the last known manufacturer or supplier of a critical process, raw material, or production or repair part. While obsolescence or diminishing resources have not traditionally been considered in measuring or achieving producibility, a product is not producible if either the design or the processes chosen contain built-in obsolescence. Nowhere is this more apparent than in the electronics industry where technology is changing by an order of magnitude every 24 months, as shown in Figure 2.4.

Predicting future process capabilities should not be restricted to evaluating advanced, high technology processes. There may be processes that have been commonly used for years by industry that could be incorporated into an enterprise's current core of

processes and yield tremendous benefits, as discussed in 1.6 - Instill a Best Commercial Practices Philosophy. Benchmarking is an effective technique for evaluating the best practices and processes of other organizations.

As with current process capabilities, candidate future technologies should be documented and tracked. Ideally, these future capabilities would be integrated into the process capability guidelines, discussed in 2.1. The importance of predicting future capabilities is illustrated in Appendix D, Case Studies 22 and 23.

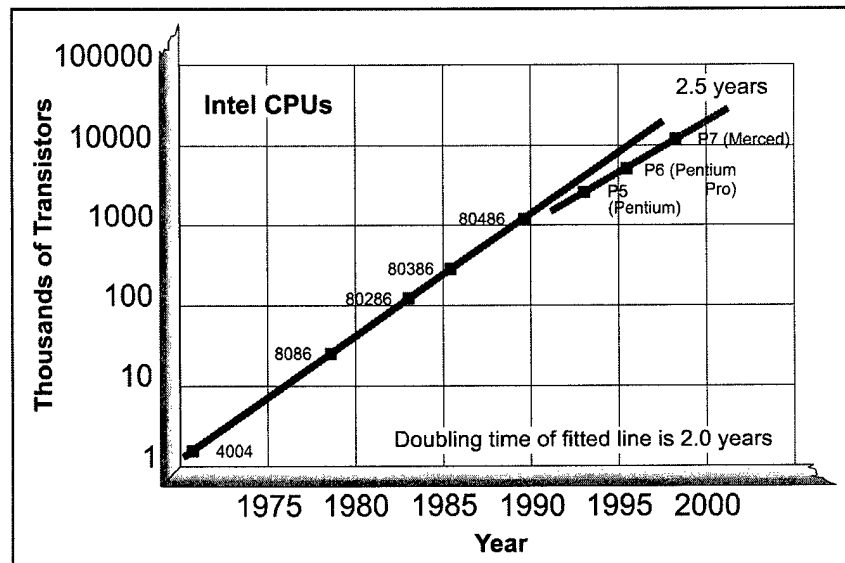

Figure 2.4 - Moore's Law for Intel CPUs

Significance

In today's dynamic environment, manufacturers must continuously evaluate, mature, and utilize new technologies to meet ever more challenging design requirements and remain competitive in their market.

Resource Requirements

Staff: The corporate process capabilities team designated by management to coordinate the organization's process capability efforts is also responsible for the coordination and integration of new technology.

Tools and Techniques: Internet searches can be used to keep abreast of technological advances and conduct preliminary technical inquiries. Benchmarking can provide information on processes used by competitors as well as by organizations in other industries. Including future process capabilities in the process capability guidelines (discussed in 2.1) might require the use of a Database Management System or a Knowledge-Based System, with Decision Support Tools, if required. Tools and techniques applicable to predicting future capabilities and the appendices in which they are found are listed in Figure 2.5.

Additionally, once the technology has been implemented internally, many of the tools presented in 2.1 and shown in Figure 2.3 would be helpful in

achieving a more thorough understanding of the capability in general, as well as its effects on a proposed product. Specifically, these include: DOE, prototyping, modeling and simulation, Six Sigma, and SPC techniques.

Tools and Techniques	Appendix
• Benchmarking	F.1.1
• Database Management Systems	F.1.3
• Decision Support Tools	F.1.4
• Knowledge-Based Systems	F.1.10

Figure 2.5 - Tools and Techniques for Predicting Future Process Capabilities

Training: Although not required, training could include courses or seminars on specific technologies.

Implementation

In general, predicting future process capabilities is the responsibility of the corporate process capabilities team, discussed in 2.1. Realistically however, all technical personnel in the organization are likely to be exposed to new technology that might have the potential for future implementation, and many will, themselves, have ideas for the development of new process technology.

Corporate management should encourage the open communication of process technology information.

Each IPT should identify process investment areas and communicate their needs to the corporate process capabilities team. The corporate process capabilities team should be tasked with providing recommendations for investment priorities. In addition, the team should coordinate efforts to ensure that new process capabilities are mature and well-understood prior to their use in a production environment and that the technology is available to those production programs that would benefit most from its use.

General steps in identifying future process capabilities are:

1. Continuously identify potential new capabilities through internal brainstorming, Internet searches, industry working groups, trade

publications and shows, and supplier strategic partnerships.

2. Evaluate candidate technologies. Assess marketing, financial, and schedule impacts as well as technical considerations.
3. Select the technology to develop internally or incorporate and mature.
4. Evaluate process capability and determine if adequate level of understanding of process capability exists.
5. If sufficient data is available, incorporate the new process capability data into the process capability guidelines (see 2.1). If the process capability is not mature and understanding of the process is not sufficient, conduct studies or analyses (see 2.1).

Section 3

Step 3. ADDRESS PRODUCIBILITY DURING CONCEPTUAL DESIGN

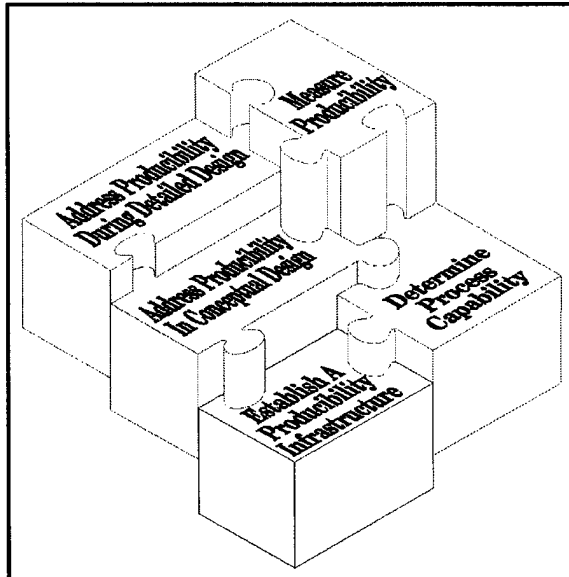

Figure 3.0 - Step 3 of the Five Steps

Address Producibility During Conceptual Design

Producibility must be addressed during every aspect of design and development in order to achieve the desired outcome of affordable products that meet the needs of the customer. During conceptual design, it is crucial that the Integrated Product Team (IPT) responsible for the product include a representative of manufacturing. It is also crucial that the IPT ensure that manufacturing issues are considered in every stage of the process. The development of a design concept is conducted by identifying possible alternatives and prioritizing them according to their ability to satisfy the goals of the product. By addressing manufacturing considerations from the beginning, the IPT ensures that the maturity of manufacturing processes is considered during the assessment of various design options. While a design and associated processes might be selected for which a particular process is technologically immature, the IPT must understand the implications of that choice and the investment needed to mature the process before production. With a management commitment to producibility (1.1) and a knowledge of the manufac-

turing processes available to the enterprise and its suppliers (2.1), producibility can be effectively addressed during conceptual design.

In this section, the five producibility system elements to address producibility during conceptual design are presented. The relationship of this step, Step 3, to the other four steps and to the notional product cycle for the development, production and support of a product in a typical manufacturing enterprise is illustrated in Figure 3.1. Also shown in this figure are the five elements of Step 3 and the time phasing of those five elements with the notional product cycle. As indicated, it is recommended that activity on some of these elements should commence prior to the start of the preliminary design phase and that some should continue into detailed design and, in one case, into the production phase. In particular, it is recommended that the identification of product goals (3.1) and the identification of key characteristics (3.2) begin before the preliminary design phase and that the development of the manufacturing plan (3.4) continue into the production phase.

Prior to significant activity on the conceptual design, it is critical that the product goals be clearly identified and understood by all the members of the IPT. The goals will generally include the desired performance characteristics, any geometric constraints, cost goals, and other considerations of importance to the customer, the members of the enterprise, and suppliers. Once the goals are clearly established and metrics to assess achievement against those goals have been identified, the key characteristics of the product can be determined. For each conceptual design element, processes, features, and cost drivers can be assessed against the desired goals. It is the responsibility of the IPT to ensure that the key characteristics of the product are understood and that all the goals can be affordably achieved.

As alternative design concepts emerge, trade studies are typically conducted. From the producibility standpoint, it is the maturity of the manufacturing processes that is of primary concern. The goal is to identify the concept that represents the best value. Prototyping as well as modeling and simulation may be used to assess elements of the concept and to evaluate the manufacturing processes needed.

As a single design concept begins to emerge, a manufacturing plan is drafted. Although it may seem

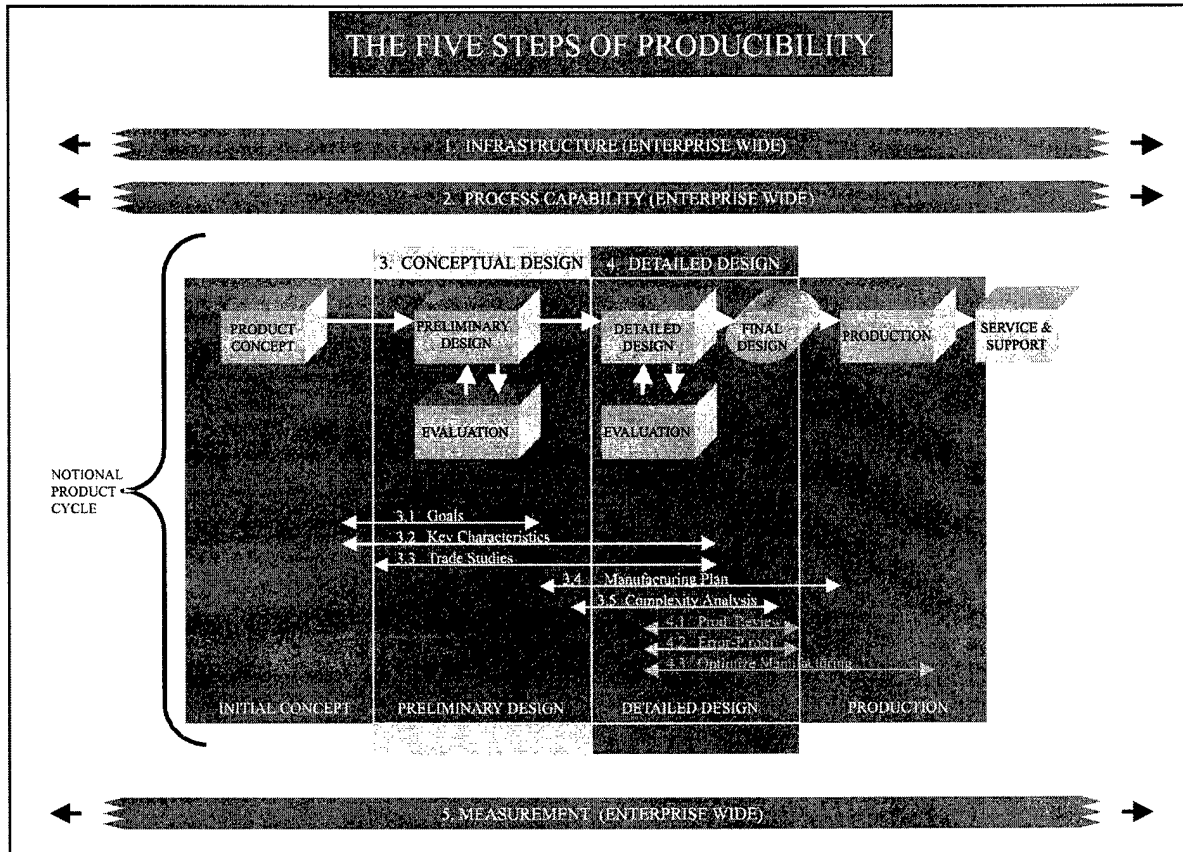

Figure 3.1 - The Five Producibility Steps

too early to create such a plan because final design details have not been defined, it is appropriate to start this effort during the conceptual design phase. Effective production requires that all necessary resources are available and sufficiently mature. At this stage in the process, the manufacturing plan becomes the basis for investments in long-lead capital equipment and the maturing of processes to support the product's manufacture.

Finally, as part of conceptual design, producibility is enhanced by an assessment of the complexity of the design. Every effort is made to ensure that the product is being designed for cost-effective manufacturing and assembly. Design simplifications may result in dramatically reduced errors during production. Attempts are made to achieve designs that can only be assembled correctly.

The five producibility system elements that are part of addressing producibility during conceptual design and a corresponding key point for each are shown in Figure 3.2.

3.1. Identify Product Goals

Description

A thorough understanding of product goals is essential to effective product development. Such goals normally encompass performance, cost, and schedule. It is the role of the IPT to assess the needs of the customer together with the capability of the enterprise and its suppliers to derive a complete set of achievable product goals. Understanding of the process capabilities of the enterprise and its suppliers, which is the objective of Step 2, is key to establishing achievable goals. Inclusion of the customer on the IPT is fundamental.

Use of techniques such as Quality Function Deployment (QFD) (see Appendix F.1.15) can assist in relating perceived customer goals to possible conceptual designs. This visual representation includes the customer requirements, the customer priorities, the design variables, and the design objectives, as well as the relationship among these key items. It is the in-

depth understanding of what is desired versus what is reasonably achievable that must be determined at the beginning of the product development process to realize a producible product downstream. Metrics must be established for all product goals so that the degree to which a design concept meets each goal can be readily understood.

Since product cost can be a critical issue, Cost Tools such as Design-to-Cost (see Appendix F.1.2), can be used for setting and achieving cost goals. The IPT is encouraged to retain design solutions that can meet the cost goal and to discard the others. It is critical to thoroughly understand the product goals *and* the process capabilities to affordably produce specific design concepts.

The importance of identifying product goals early in the product development cycle is highlighted in Case Studies 24 through 27 in Appendix D.

Significance

Setting appropriate and realistic goals is critical to successfully producing affordable products that meet the needs of the customer and that are available when needed.

Resource Requirements

Staff: Early involvement of all functional area representatives including the customer and suppliers on an IPT is required.

Tools and Techniques: QFD (see Appendix F.1.16) is an excellent technique for assessing the needs of the customer against the possible design variables. It provides a basis for the IPT to identify key goals and the relationship between those goals and the key product attributes. Cost models that relate the goals to the potential designs should also be maintained. The use of the Cost Tools discussed in Appendix F.1.2 can provide assistance in focusing on cost.

Training: It is beneficial to provide the IPT with training on QFD and Cost Tools.

Producibility System Element	Key Point
3.1 Identify Product Goals	Set appropriate and realistic goals based on customer needs.
3.2 Identify Key Characteristics	Identify design features with the greatest impact on meeting product goals.
3.3 Perform Trade Studies on Alternative Product and Process Designs	Assess alternative design concepts against product goals including producibility considerations.
3.4 Develop a Manufacturing Plan	Identify manufacturing processes including factory requirements. Highlight process development and long-lead capital equipment needs.
3.5 Perform a Complexity Analysis	Simplify product design and manufacturing processes to reduce manufacturing and assembly difficulties and prevent cost and schedule problems.

Figure 3.2 - Key Points of Step 3 - Address Producibility During Conceptual Design

Implementation

The key to identifying realistic product goals is to involve all organizational elements of the enterprise as well as representatives of the customer and the suppliers in the establishment and assessment of the goals. The formation and use of an IPT that includes these members from the beginning of the design process is the most effective means to achieve success. It is insufficient to have the customer provide the goals and then have the design team decide how to address them. Affordable production of useful products results from a cooperative understanding of all parties regarding the implications of customer requirements on the producibility of the product. Hence, the setting of goals should be done by the IPT and should be revised, as necessary, as additional information on design concepts and on the maturity of production processes is obtained.

As noted previously in 1.2, it is recognized that, for some products, the participation of a customer on the IPT may not be possible. Since it is important that the voice of the eventual customer be included in all deliberations, it is recommended that, in the least, the customer should be represented on the IPT by a member of the marketing organization of the enterprise.

Although not required, it is useful to employ such tools and techniques as QFD and Design-to-Cost (DTC) to assist in establishing and assessing product goals. What is most important is developing an understanding that goals must be set and that they must be based on the needs of the customer and the capability to affordably produce the product. In

addition, it is good practice to measure progress toward the goals to identify critical areas for additional emphasis.

Some specifics regarding the identification of product goals include:

1. Form a multi-disciplinary team (an IPT) that includes the customer(s), suppliers, and all organizational elements of the enterprise (sales, marketing, accounting, design, engineering, manufacturing, product service, and support, et al).
2. Identify all the customer desires for the product and prioritize.
3. Maintain a method for tracking potential design concepts and maturity of manufacturing processes against the customer desires. (QFD can be used.)
4. Based on the desires and the known capabilities of the enterprise and suppliers, agree on a set of product goals.
5. If appropriate, set specific cost goals and design the product to meet those goals. Addressing producibility early has significant cost leverage.
6. As trade studies are conducted (see 3.3), review the cost, schedule, and performance impacts of various design concepts and adjust the goals as agreed by the IPT.

3.2 Identify Key Characteristics

Description

Once the product goals have been determined and preliminary design concepts are beginning to be considered, it is important to identify the key characteristics of the product. From the producibility point of view, the key characteristics are those product attributes that will have the greatest impact on product performance and manufacturing time, cost, and schedule. The identification of key characteristics is the process whereby the key cost, schedule, and performance drivers are identified and their importance defined. The process is based on the requirements of the customer as well as all the lower level requirements that define the concept. Such characteristics can include specific materials, manufacturing and assembly processes, and product features. It is the responsibility of the IPT to identify key characteristics.

The identification of the key characteristics is assisted by employing the QFD technique noted in

3.1. It may also involve the use of Design Failure Mode and Effects Analysis (DFMEA) tools (see Appendix F.1.7) to help identify potential design flaws that can be related to manufacturing. The key characteristics assessment also can assist in the identification of possible complexities in the product—that is, the features that can be simplified to achieve a more affordable product (see 3.5). It can also assist in early identification of possible show-stoppers, characteristics that will result in the inability to deliver the product in accordance with the goals.

The objective is the identification of those key characteristics that are essential to meeting the product goals so that resources can be focused on those key items. The benefits of such a process and its application are presented in Appendix D, Case Studies 27 through 29.

Significance

Identifying key characteristics, which begins with the customer's product requirements and flows down to lower level requirements, can significantly improve quality and reduce cost and product realization time.

Resource Requirements

Tools and Techniques: QFD (Appendix F.1.16) and DFMEA (Appendix F.1.7) tools can be employed to assist in the identification of key characteristics.

Training: The IPT should be trained in the identification and use of key characteristics for the assessment of product concepts. Training in QFD and DFMEA is helpful.

Implementation

As for the determination of product goals (3.1), the principal instrument for the determination of key characteristics is the IPT. The classical product development process begins with the statement of product goals from which product specifications are derived. Typically, little effort is expended on prioritizing the goals or the resulting specification. Indeed, resources are expended on all elements of the product without regard to priority rather than focusing resources on the critical few features that are key to customer satisfaction.

The approach recommended here employs the QFD technique (Appendix F.1.16) introduced in 3.1. Since the IPT members represent all elements of the enterprise as well as the customer and suppliers, it is capable of applying QFD to prioritize the product

goals, array them against possible design approaches, and identify those characteristics of the product that are key to achieving customer satisfaction. The IPT can then ensure that resources are focused on the key characteristics. The basic steps are:

1. Array customer-driven product goals against product design attributes that can achieve the goals.
2. Prioritize customer goals.
3. Identify key design attributes (the key characteristics) that are required to achieve the critical goals.
4. Decompose the key characteristics to the lowest level possible in order to highlight all required actions.
5. Document and communicate the key characteristics to the entire design team.

3.3. Perform Trade Studies On Alternative Product And Process Designs

Description

A trade study is a formal decision-making method that can be used to solve many complex problems. Trade studies (also called tradeoff studies or analyses) are used to rank potential design solutions against the product goals. In the context of this document, the trade study can highlight the manufacturing advantages and disadvantages of each design concept. Process maturity, ease of assembly, manufacturing risk, and need for capital equipment are among the elements considered during the trade studies from the producibility perspective. The objective is to identify a design solution that most effectively meets all the product goals.

During the conceptual phase, trade studies can help identify possible designs that will result in an optimum balance of quality, functionality, cost, performance, and producibility. Product goals (3.1) and key characteristics (3.2) may be revisited and changed, as appropriate, based on the results of the studies.

Ideally, trade studies are conducted according to the principles of good experimental practice. Two or more design concept strategies with different values of an independent variable such as size, shape, or weight are compared using a dependent variable such as speed, energy use, reliability, or manufacturing process maturity. Tradeoff decisions are more meaningful when extraneous variables are kept constant or otherwise controlled. Producibility may be either

an independent or dependent variable depending on the requirements, but it should always be a documented variable. Producibility measurements can be related to cost, schedule, quality, complexity, and risk. The trade study's quality depends on the quality of the input data. The results will be unreliable if the input data comes only from peoples' memories, estimates, or best guesses. To be viable, trade studies must be based on fact.

Examples of the importance of trade studies in the product development cycle to producibility are presented in Case Studies 30 through 34 in Appendix D, and Appendix E.1 contains a more detailed presentation of the tradeoffs considered on a complex cover assembly for a surveillance system for the U.S. Army.

Significance

In areas where a trade study is performed, the IPT will identify design alternatives and determine rationale in support of design decisions. Then, working with the customer as a member of the IPT, the team can modify the product goals – if justified by the data. Further, the documentation of the alternatives and rationale will provide valuable references should the issue require revisiting. The tradeoff analysis process allows the IPT to make optimum decisions, taking into account the goals, the confidence levels of the trade studies, and the interdependencies among the requirements.

Resource Requirements

Staff: The IPT should take the lead in the trade studies. Other staff members may be brought in for their expertise. The evaluation should be conducted by the personnel who are most knowledgeable of the details of the product and who are technically qualified to perform the analyses.

Tools and Techniques: A wide range of tools are applicable to the trade study process. Figure 3.3 lists the tools and techniques included in Appendix F that can be applied to this producibility element.

Training: Depending on the extent and complexity of the study, training in the process of performing a trade study may be required. Training in the use of the tools and techniques in Figure 3.3 is useful but not required.

Implementation

Trade studies are used to assess potential design solutions. The objective is to identify a design concept that balances each of the product goals to

achieve a product that cost-effectively meets the customer's needs. From a producibility perspective, the IPT must be certain that the manufacturing techniques associated with each potential design are assessed and are considered in the tradeoff process. Attention must be given to both the maturity of the processes (see 2.1) and the availability of material, equipment, and staff in the enterprise and at suppliers. Consideration should also be given to outsourcing of some or all of production. Finally, the IPT must be cognizant of the effect material selection has on the ability to produce an affordable, quality product, on schedule. Basic steps in performing trade studies are:

1. Form the multi-disciplinary team that will conduct the trade studies. The team may be the basic IPT or portions thereof, with augmentation by functional experts as necessary. Customer involvement is strongly recommended.
2. Define the parameters of the trade study alternatives.
3. Modify the product goals if appropriate.
4. Determine the approach and resources required.
5. Evaluate and select the preferred alternative.
6. Validate the study results through simulation, prototyping, and testing.
7. Iterate more detailed trade studies through the design process as required.
8. Thoroughly document the study and results.

3.4 Develop A Manufacturing Plan

Description

A manufacturing plan identifies the processes used to create a producible product and is developed before the individual documents such as design drawings, tool designs, and work instructions are finalized. During the plan's development, the IPT reviews and agrees on the processes required to control the key characteristics of the product during production. The manufacturing plan includes factory requirements, teaming agreements, and supplier interface guidance.

The plan is drafted during conceptual design in order to further the understanding of the manufacturing processes that may be required and the maturity and availability of those processes. In order to be able to produce products in a timely manner after final design is completed, the manufacturing plant

Tools and Techniques	Appendix
• Benchmarking	F.1.1
• Cost Tools	F.1.2
• Design for Manufacture / Assembly (DFMA)	F.1.5
• Design Failure Mode and Effects Analysis (DFMEA)	F.1.7
• Process Failure Mode and Effects Analysis (PFMEA)	F.1.7
• Modeling and Simulation	F.1.13
• Producibility Assessment Worksheet (PAW)	F.1.14
• Prototyping	F.1.15
• Rapid Prototyping	F.1.17

Figure 3.3 - Tools and Techniques for Performing Trade Studies

must have the equipment, materials, and processes available. Planning for capital equipment must begin during conceptual design and may require purchasing prior to the completion of the conceptual design phase depending on acquisition and set-up lead-times. Likewise, process development and maturation may be required. The identification of processing capability and the importance of understanding these capabilities are discussed in Step 2. As in 3.3, manufacturing planning should also include consideration of outsourcing of all or part of production. The early development of a draft plan provides the IPT with insight into this information. It also provides information to be used in the trade studies (3.3) since it provides the equipment, material, and process development expenses related to the design concepts.

The development of the manufacturing plan continues through the detailed design phase of the product and is not completed until manufacturing has commenced. Updating of the manufacturing plan occurs during production if either the design or the processes change.

Significance

The manufacturing plan should be created early during conceptual design and be updated throughout detailed design and production. The plan can help identify and highlight risk areas for mitigation in the planned design.

Resource Requirements

Staff: The IPT is responsible for developing the manufacturing plan. Appropriate manufacturing and assembly expertise should be added to assist as needed.

Tools and Techniques: Manufacturing Planning Tools range from very simple spreadsheets to more sophisticated tools such as Material Requirements

Planning (MRP), Manufacturing Resource Planning (MRP II), and Enterprise Resource Planning (ERP). Manufacturing Planning Tools are discussed in Appendix F.1.11.

Training: Training on any Manufacturing Planning Tools, such as MRP, MRP II, or ERP, implemented by the organization, is required. Training is usually supplied by the vendor of the applications.

Implementation

Once the trade studies have resulted in a reasonable set of possible designs, the development of the manufacturing plan should begin. The purpose of this plan is to initiate the identification of manufacturing needs that may require investment. These may include the need to purchase capital equipment, the need to invest in maturing manufacturing processes, the need to change the layout of the factory floor, the hiring of personnel with specific expertise, and the need to identify vendors and suppliers who can manufacture all or part of the product. With regard to process maturity, the process capability guidelines discussed in Step 2 provides the corporate resource for understanding current and future processes.

Basic steps in developing a manufacturing plan are:

1. Analyze product requirements for specific design concepts.
2. Identify fabrication and assembly processes required and relate to the current processing capabilities (2.1).
3. Identify tooling approaches.
4. Identify resource requirements (work force and equipment).
5. Identify risk areas in processes, schedule, and cost.
6. Disseminate and review the plan with the IPT.
7. Update as the product configuration matures.

It should be noted that the manufacturing plan development continues into the production phase until full production of the final product is underway as shown in Figure 3.1.

3.5. Perform A Complexity Analysis

Description

Prior to final design, a complexity analysis of the selected design concept should be performed. The purpose is to identify those attributes of the design that may be overly complex or that may require overly complex manufacturing and assembly procedures. The intent is to attempt, if possible, to eliminate all such features. If they cannot be eliminated, then the analysis can form the basis for identifying additional efforts that may be necessary to ameliorate manufacturing and assembly difficulties. This analysis is most beneficial when performed by an independent team.

An example of reducing part count with the objective of reducing complexity is shown in Figure 3.4. In this redesign of a conference badge clip, a ten part assembly with fifteen assembly operations has been reduced to a single part. Reducing part count may result in beneficial reductions in assembly time and assembly errors and may prevent a possible assembly work stoppage due to missing parts. However, the manufacture of single part badge holder might introduce other complexities such as the need for a new and/or poorly defined process or a difficult operational sequence and may, in the end, result in a more expensive product whose cost cannot be justified. An independent assessment of complexity is often necessary to determine the best course of action.

Case Studies 34, 35, and 36 presented in Appendix D provide additional insight into the reduction of complexity on a variety of different products in a number of industries.

Significance

Complex design attributes or features may require the acquisition of new machinery, processes, or personnel capabilities. Complex designs may cause schedule problems and cost overruns, as they present

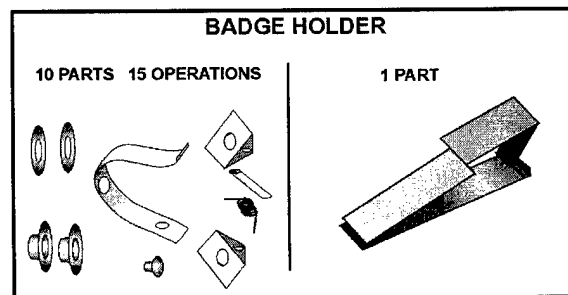

Figure 3.4 - Badge Holder: Ten Part Assembly vs. Single Part

significant risk areas and may cause impact on production by requiring an unplanned, last minute, modification to the product or process. The complexity analysis can result in simplifications to the design and recommendations to reduce manufacturing and assembly difficulties.

Resource Requirements

Staff: The formal complexity analysis should be conducted by a team of independent experts in all disciplines associated with the product and should include at least one producibility engineer who is expert at complexity analysis.

Implementation

Once the preliminary manufacturing plan (3.4) has been developed, a complexity analysis of the product and the processes should be performed to attempt to prevent manufacturing cost and schedule problems. The analysis should be conducted by an independent team of experts who are familiar with complexity analysis.

Steps in conducting a complexity analysis include:

1. Assemble the independent review team.
2. Determine complexity metrics to be assessed (design attributes or features, part count, process required, schedule, cost, tooling, etc.).
3. Analyze design against complexity metrics.
4. Recommend modifications to the design, as appropriate, and, as needed, to the manufacturing plan to incorporate the recommendations.
5. Document all assessments, analyses, and recommendations.

The recommendations of the complexity analysis team should be presented to the IPT in a formal transmittal both orally and in writing. It should be noted that the IPT does not have to follow all the recommendations of the review team. In the end, the IPT is responsible for the product.

Section 4

Step 4. ADDRESS PRODUCIBILITY DURING DETAILED DESIGN

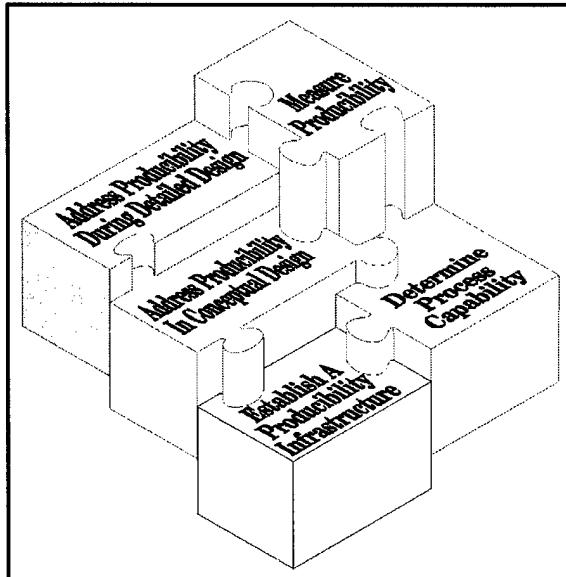

Figure 4.0 - Step 4 of the Five Steps

Address Producibility During Detailed Design

As indicated in the previous section, producibility must be addressed during every aspect of the design and development of a product in order to achieve the desired outcome of affordable products that meet the needs of the customer. During detailed design, it is crucial that the Integrated Product Team (IPT) responsible for the product continue to include a representative of manufacturing. As the product transitions to a final detailed design, the IPT must ensure that every aspect of producibility has been addressed. During this stage of the process, the IPT must continue to focus on the needs of the customer as stated in the product goals (see 3.1) and on the product's key characteristics (see 3.2). As part of detailed design, product and process data are definitized through prototyping and testing of hardware and processes. It is during detailed design that the manufacturing plan, started as part of Step 3 (see 3.4), is fully developed.

In this section, the three elements to address producibility during detailed design are presented.

The relationship of this step, Step 4, to the other four steps and to the notional product cycle for the development, production and support of a product in a typical manufacturing enterprise is illustrated in Figure 4.1. Also shown in this figure are the three elements of Step 4 and the time phasing of those elements with the notional product cycle. As shown, it is recommended that activity on all of these elements should commence soon after the start of the detailed design phase, but that optimizing manufacturing (4.3) should continue almost to the end of the production phase.

Engineering reviews using personnel who have not been involved in the product development are a traditional method for assessing the maturity of a design. In most cases, these reviews are conducted periodically during the design phases. With respect to producibility, a specific producibility engineering review (4.1) focused on the maturity of manufacturing processes is an essential step in achieving affordable products. Such a review should be accompanied by efforts to error-proof the design (4.2) and to optimize manufacturing (4.3). As described in this section, these three activities are inter-related. Although presented here as three separate elements, it is common practice to execute all three elements together, since they complement each other, to result in a final detailed design of a product that can be affordably manufactured.

With a management commitment to producibility (see Step 1), a knowledge of the manufacturing processes available to the enterprise and its suppliers (see Step 2), and attention to producibility during both conceptual design (see Step 3) and detailed design (Step 4), the enterprise can significantly enhance the producibility of its products.

The three producibility system elements that are part of addressing producibility during detailed design and a corresponding key point for each are shown in Figure 4.2.

4.1. Conduct Producibility Engineering Review

Description

The intent of a Producibility Engineering Review is to focus on manufacturability and not on the product's

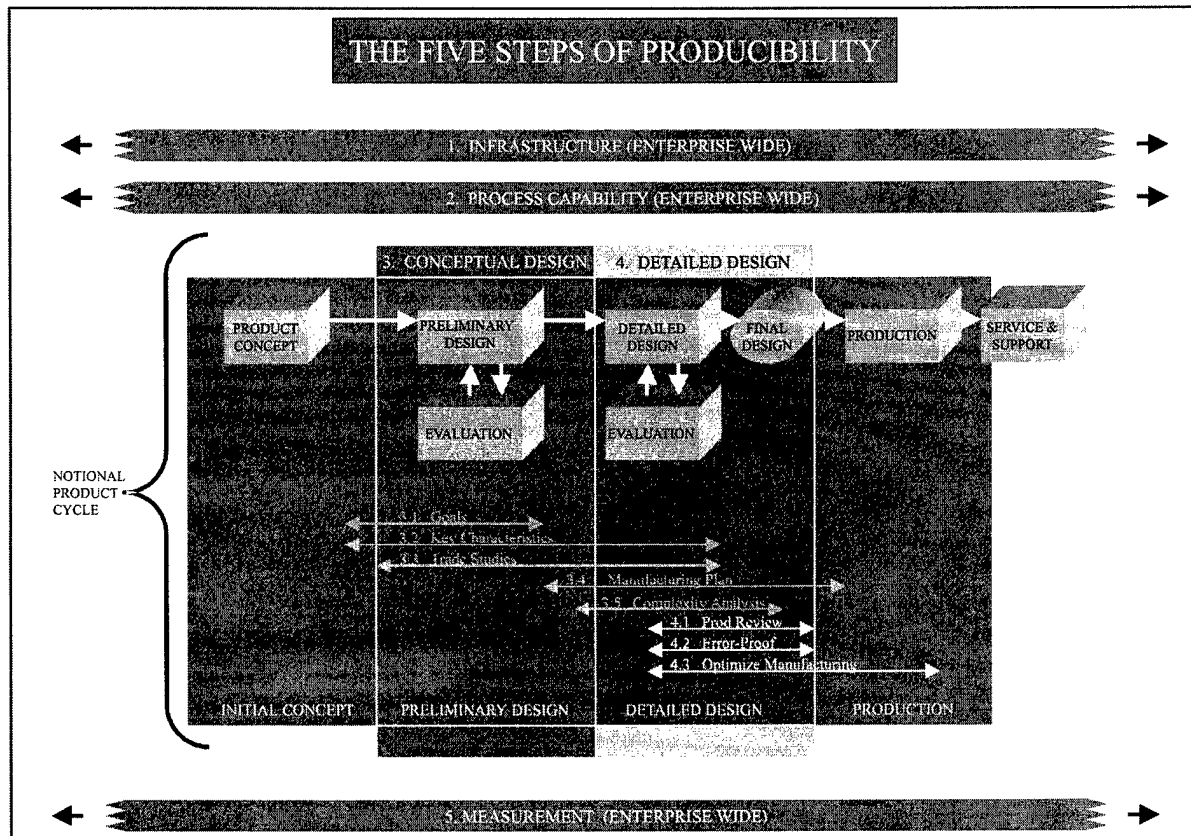

Figure 4.1 - The Five Producibility Steps

functionality. The goal is to identify manufacturing and assembly difficulties and potential problem areas. New process capabilities can then be traded off if the requirements exceed present capabilities.

As part of the Producibility Engineering Review, detailed attributes of the product under design are compared with documented process capabilities. This review is used as a checking mechanism to ensure that the product, as designed, can be produced with available manufacturing capabilities. This systematic, thorough evaluation is a necessary step in achieving enhanced producibility. The review can be conducted at one time or it can be done either continually or at pre-defined points in the design process.

The producibility engineering review is conducted in addition to normal and necessary design reviews. These latter reviews are conducted by the IPT throughout the design process and should be used to assess progress against the goals and metrics for the product. Since it is imperative that the IPT maintain a focus on producibility, the regular design reviews

address many producibility issues. However, they are typically focused on individual processes and components and normally include tool, production, and facilities planning for those processes.

In contrast, the focus of the producibility engineering review expands to an evaluation of whether the entire product can be manufactured in the intended facility within the given schedule and budget. Internal experts who are not part of the product IPT nor involved in the product development are normally brought in to conduct this review.

Two examples of the application of producibility reviews are presented in Appendix D, Case Studies 37 and 38. An industry example of a checklist and sequence of reviews used for assessing producibility during design is presented in Appendix E.3.

Significance

The Producibility Engineering Review can ensure that the product can be manufactured effectively and affordably within the allowable time frame.

Resource Requirements

Staff: Experts from manufacturing engineering, design engineering, and materials engineering; production and quality personnel; and key suppliers are necessary to conduct these reviews.

Tools and Techniques:

Design for Manufacture / Assembly (DFMA) and Tolerance Analysis are two of the tools that can assist the review team in compiling and analyzing producibility engineering information. Descriptions of these tools are presented in Appendix F.1.5 and F.1.23, respectively.

Training: It may be necessary to introduce team members to DFMA concepts and Tolerance Analysis methods for evaluating designs.

Implementation

As in many of the previous elements, the IPT is the essential mechanism for ensuring that the producibility engineering review is conducted. It is preferable that a separate review team be established to conduct the review. This team should be composed of staff members of both the enterprise and its suppliers who are not on the product IPT and who are not directly involved with the development of the product. As with the product IPT, this team should be structured as an IPT and should include representatives of all the key areas (see 1.2) as well as experts in manufacturing and design. Knowledge of the process capabilities should be available from the process capability guidelines (see 2.1) and also may be garnered from internal or external experts. As noted previously, this review can be conducted all at once or at various times during the design process. However, it should be conducted together with the activities described in the following two elements (see 4.2 and 4.3) due to the interdependence of these activities.

The basic steps for the producibility engineering review process are:

1. Identify the individual product attributes.
2. Identify the materials used in the design and any special manufacturing considerations.
3. Determine if the design can be produced using existing process capabilities.

Producibility System Element	Key Point
4.1 Conduct Producibility Engineering Review	Determine if design can be produced with available manufacturing capabilities.
4.2 Error-Proof the Design	Simplify the design to minimize production errors.
4.3 Optimize Manufacturing	Use prototypes and simulations to evaluate the design and the manufacturing floor capabilities. Conduct final design trade-offs.

Figure 4.2 - Key Points of Step 4 - Address Producibility During Detailed Design

4. Assess the ability of manufacturing to produce the product during the required schedule.
5. Review the impact of the design with regard to the tooling plan.
6. Determine if conflicting requirements can be resolved by either an enhancement of internal/external capabilities or product redesign.

After the review is completed and the other two elements of this step are conducted (4.2 and 4.3), the IPT should:

1. Update the manufacturing plan.
2. Complete the Engineering Release Package for the product.

4.2. Error-Proof the Design

Description

Another key element to achieve enhancements in producibility is to error-proof the design. This oft-overlooked activity can have a remarkably big payoff in the reduction of manufacturing errors that can result in the need for rework and/or the production of scrap. The goal is to eliminate the causes for error, minimize the possibilities of error, and make errors that do occur more readily detectable. In simple terms, this goal is accomplished by designing products so that they can only be assembled the correct way and by using manufacturing processes that can only be implemented correctly. In reality, this goal may be unattainable for every product. However, by striving to identify opportunities to meet the goal, producibility will be enhanced. The importance of error-proofing to producibility can be seen in Case Study 39 in Appendix D.

An error-proof design is one in which the design team has considered ways to eliminate or reduce the occurrence of mistakes during manufacturing, as-

sembly, and maintenance processes. A Failure Mode and Effects Analysis (FMEA) can assist in the identification of potential failure modes and in understanding the manufacturing process implications.

An example of eliminating an opportunity for errors is shown in Figure 4.3. In this redesign, a small lip was added to prevent installation of the bracket on the wrong side of the flange.

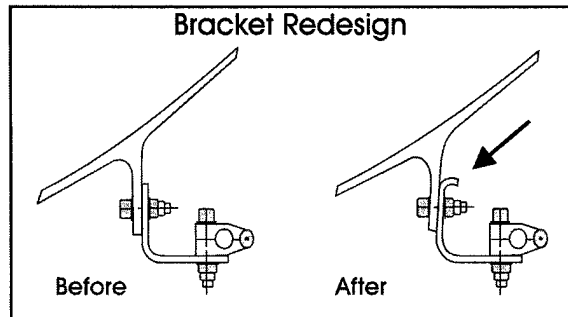

Figure 4.3 - Error-Proofed Bracket Design

Significance

Because errors represent a major cause of failures and defects, alleviating or eliminating the opportunity for errors has a significant impact on producibility.

Resource Requirements

Staff: Required staff includes all members of the product development team.

Tools and Techniques: The application of FMEA to assess the manufacturing and assembly processes will assist in the identification of potential errors. A description of FMEA is provided in Appendix F.1.7.

Training: Workshops to introduce the product designers to the concept of error-proofing and to provide them with examples and guidelines are available.

Implementation

In many cases, the opportunity for errors can be eliminated by simplifying the design or manufacturing operation. Hence, the design should be reviewed to identify features that can be changed to eliminate potential errors. For all potential errors identified, an attempt should be made to redesign to eliminate the possibility of an error. If this is not possible, an attempt should be made to redesign so that it is obvious that an error has occurred. At the very least, an attempt should be made to redesign so that, if the

error occurs, it can be easily identified as an error and corrected with minimum impact.

Finally, the design should be reviewed with the manufacturing personnel who will actually produce the product to review the potential for processing and assembly errors. Based on that review, design modifications should be made, if appropriate.

The design engineer should apply the following guidelines to help error-proof the design:

1. Maximize part symmetry or make parts *obviously* asymmetrical.
2. Ensure adequate access and unrestricted vision during assembly.
3. Eliminate adjustments.
4. Design self-locating or self-aligning parts.
5. Design parts that cannot be installed incorrectly.
6. Standardize all accessory parts such as fasteners.
7. Provide visibility and feedback to the operator such as making relevant parts visible and displaying system status by making the effects of operations immediate and obvious. For example, make a part number visible and easily readable when the part is installed properly.

Before a detailed design is approved and released, the following questions should be addressed:

1. Does the system design and the associated manufacturing processes make it difficult to take wrong actions?
2. Is it easy to discover errors that have occurred?
3. Has the design been standardized to every extent possible?
4. Is it easy to correct errors if they are made?

4.3. Optimize Manufacturing

Description

This element involves the final tradeoffs of design details and manufacturing capabilities to arrive at a final detailed design configuration that will enable on-time, error-free, affordable production. As in error-proofing the design (see 4.2), optimizing manufacturing is a goal. The objective is to continuously improve both product design and process capabilities.

During the detailed design phase, trade studies can assist in arriving at an optimum balance of quality, functionality, cost, performance, and producibility. Most of the techniques used to trade conceptual designs (see 3.3) can now be used to assess detailed designs.

In this step, prototypes are manufactured or purchased, testing is conducted, and simulations of the planned manufacturing processes are evaluated. Virtual prototypes and the use of simulations can reveal changes required prior to any actual manufacturing. Physical prototypes can be tested extensively to provide data to support the achievement of the design goals as well as for process control variables. Process maturity, ease of assembly, and manufacturing risk continue to be key elements considered during these final trade studies. Prior to final design release, it is appropriate to review the manufacturing plan for the design to attempt to identify improvements. Prototyping of product and process, using either real mock-ups or computer simulations, can assist in identifying opportunities for improvement.

Factory floor, assembly, and process simulation tools can provide a cost-effective evaluation of the manufacturing plan before any product is manufactured. Manufacturing system simulation may be used to model the overall production process, material flow, and schedules, while process simulations help predict the outcome between individual processes and the product's characteristics.

Advances in solid modeling and improvements in computer performance make it possible to perform a comprehensive analysis of virtual parts and to assess the capability of processes before actual manufacturing begins. Tolerance analysis tools allow users to simulate different tolerance stack-up conditions that are likely to occur during a manufacturing process. Modeling software also allows designers to model the behavior of mechanical systems under real-world conditions.

Case Studies 40 and 41 in Appendix D are examples pertinent to a discussion on optimizing manufacturing.

Significance

Improving manufacturing before production begins can result in more efficient and effective processes.

Resource Requirements

Staff: Designers, manufacturing engineers, industrial engineers, and simulation support staff.

Tools and Techniques: The tools used in the tradeoff studies begun in 3.3 are also applicable here. Such tools include Benchmarking, DFMA, Modeling and Simulation, Prototyping, and Rapid Prototyping. In addition, Manufacturing Simulations are suitable for analyzing the entire factory floor operation before production, and Root Cause Analysis (RCA) is helpful in identifying inherent problems in either products or processes and in determining possible corrective action. These tools are shown in Figure 4.4.

Training: Training may be required for the application of DFMA and Benchmarking. Training is a necessity to enable effective use of manufacturing simulation software. Most software vendors offer training courses on their products.

Implementation

The IPT must lead an effort to assess the manufacturing plan to identify opportunities for improved manufacturing processes. If available, simulation tools and models of both the product and the manufacturing processes should be developed to assist in this evaluation. Prototypes of hardware and processing techniques can also be employed. The objective is to identify simplifications in product and process that can result in more efficient manufacturing and to insert new process and product technologies in an effort to improve manufacturability before final design release. Processes should be evaluated based on the capability of the company and its suppliers (see Step 2) and assessed with respect to the key characteristics of the design (see 3.2). Lessons learned from these tradeoffs should be made available to the design guidelines team for inclusion in the corporate design guidelines (see 1.5) and to the corporate process capability team for inclusion in the process capability guidelines (see 2.1).

Tools and Techniques	Appendix
• Benchmarking	F.1.1
• Design for Manufacture / Assembly (DFMA)	F.1.5
• Manufacturing Simulations	F.1.12
• Modeling and Simulation	F.1.13
• Prototyping	F.1.15
• Rapid Prototyping	F.1.17
• Root Cause Analysis	F.1.19

Figure 4.4 - Tools and Techniques for Optimizing Manufacturing

There are a variety of simulation tools and models that can be applied to assessing the manufacturing systems, processes, and products to quickly assess producibility issues. Because costs can be considerable with simulation, it is not applicable for all sizes and types of organizations. Organizations need to determine the potential payoff before applying simulation technology in any particular area. Use of consultants may provide alternatives to a large investment in simulation technology.

The basic steps for optimizing manufacturing are:

1. Develop a statement that clearly specifies the problem to be investigated.
 2. Identify the team members participating in the study.
 3. Specify the performance measures that will be used to evaluate the results.
 4. Identify candidate solutions such as alternative models to be considered.
 5. Build physical prototypes or develop simulation models.
 6. Conduct tests on virtual or physical prototypes to assess the performance measures of item 3 above.
 7. Simulate the factory floor manufacturing and assembly processes.
 8. Conduct trade studies using information obtained in items 5, 6, and 7 above.
 9. Evaluate results.
 10. Select course of action.
-

Section 5

Step 5. MEASURE PRODUCIBILITY

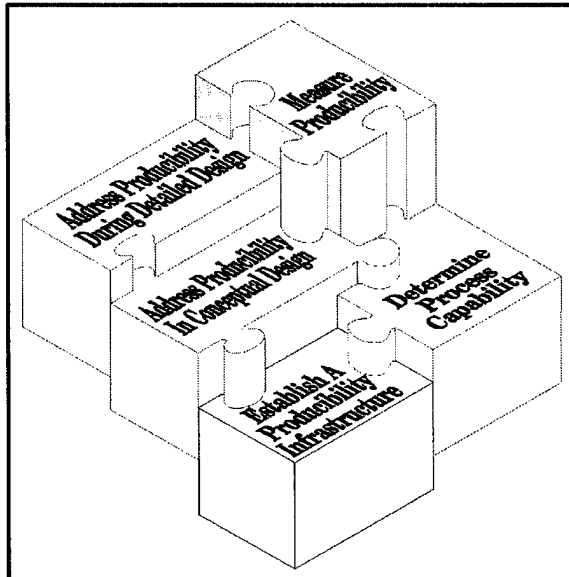

Figure 5.0 - Step 5 of the Five Steps

Measure Producibility

Effective measurement is critical to an accurate assessment of producibility. It is the key to understanding an organization's capability to produce a product and the accuracy of the product produced. It is a tool for evaluating the effectiveness of producibility performance and for determining the degree to which improvements need to be made to ensure that future products are producible. Included in the management commitment to producibility (1.1) is the commitment to measure all aspects of the corporation, its products, and processes to continuously assess progress towards the enhancement of producibility. As mentioned previously in this document, a world-class, best practices enterprise bases its business judgements on fact and not on opinion. Measurement is the process by which facts are gathered.

Producibility is the relative ease by which a product, which meets the customer's quality, cost, and schedule requirements, can be manufactured. To assess producibility on a product level, both the product and its manufacturing processes must be measured. Processes must be monitored and con-

trolled, through measurement, to ensure that they can repeatedly produce accurate, high-quality products. The goal of process monitoring and control is to limit process variability to a tolerable range. Process variability results in product variability, and product variability, when outside of design limits, means unacceptable quality. As a general rule, reducing process variability improves product quality and, therefore, producibility.

The effectiveness of an organization's producibility system or producibility approach in general cannot be measured using set rules or guidelines. Each organization is very different, and approaches to producibility vary widely. In general, to assess producibility on an enterprise level, an organization must first evaluate its producibility performance on a product-by-product basis. Analysis of producibility on a per-product basis allows the organization to better understand the strengths and weaknesses of its producibility system or enterprise-wide producibility approach, so that enhancements can be identified.

Fundamental to measurement of any kind is the setting of measurable goals and metrics. Metrics, in this case, are an objective means of measuring producibility performance as well as overall producibility system effectiveness. Establishing goals and applicable metrics forces the organization to focus in on those measurements critical to ensuring or enhancing producibility. While the old saying, *you can only manage what you measure*, certainly applies to producibility efforts, care should be taken to measure only what is important to measure and what will provide the organization critical information on which to base decisions regarding future actions. Collecting data for data's sake is neither effective nor economically reasonable. Too much data or irrelevant data compounds difficulties in analysis and often hinders, rather than highlights, the identification of the proper course of action.

The relationship of this step, Step 5 - Measure Producibility, to the other four steps and to the notional process flow for the development, production, and support of a product in a typical manufacturing enterprise is illustrated in Figure 5.1. Measurement is critical to producibility and permeates the other four steps. Shown as an enterprise-wide

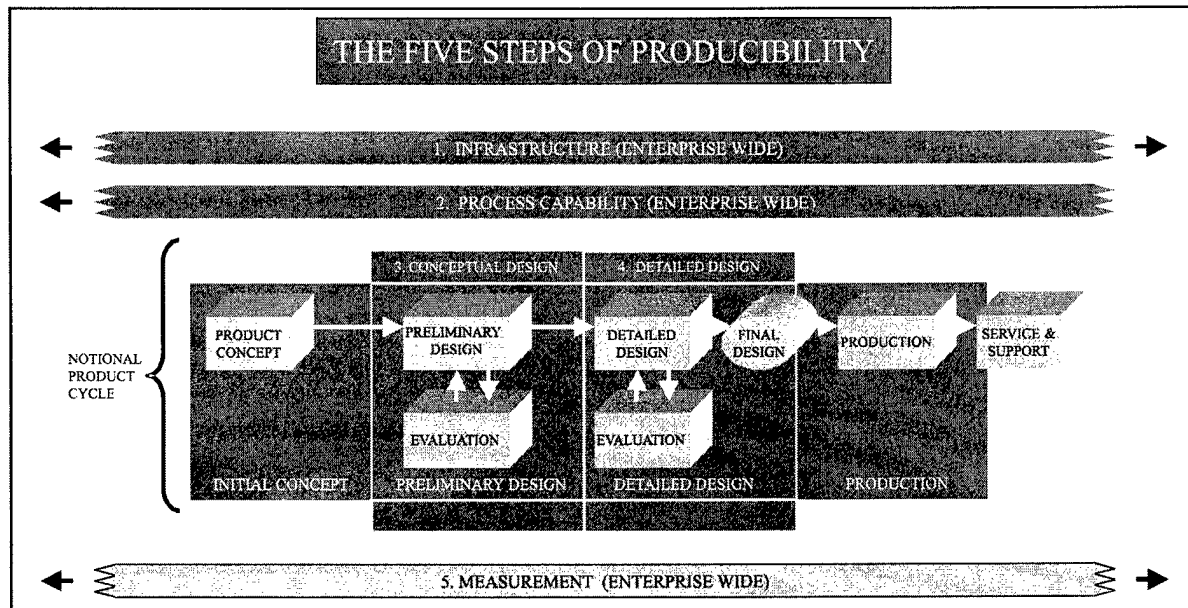

Figure 5.1 - The Five Producibility Steps

function, Step 5 provides the information critical to an assessment of producibility on both a per-product and system (enterprise-wide) basis. It is this information, when fed back into both the design guidelines (1.5) and the process capability guidelines (2.1), that provides the foundation for continuous improvement in producibility.

Figure 5.2 illustrates the continuous improvement cycle of the producibility system of the corporation and how that improvement is driven by the elements of this step. Whatever the state of the current system, each product development is driven by the knowledge of the corporation as to the capabilities of its current processes and the design guidelines that have emerged from past experience. The process information should be available in process capability guidelines that are developed and maintained by a corporate process capabilities team (see 2.1). In addition, a corporate design guidelines team should develop and maintain design guidelines (see 1.5). As illustrated in Figure 5.2, the process information is used in every phase of the notional product development cycle, and the design guidelines are used in the preliminary and detailed design phases. This knowledge base is part of the core competency of the organization. It is the basis for a competitive advantage in product development and manufacturing.

Producibility element 5.1 describes the importance of measuring an organization's processes and discusses a number of tools that aid in both process

measurement and control. The information gathered from these measurements is used during manufacturing to control processes and can be the basis for modifying manufacturing processes and procedures as well as modifying the design of the product. As shown in Figure 5.2, this data is fed back to the process capability guidelines to increase the corporate knowledge of what works well and what does not. This lessons-learned information enhances the ability to develop and produce succeeding products more effectively and efficiently.

Producibility element 5.2 addresses the necessity of measuring products and describes the types of measurements that provide useful information in assessing the effectiveness of producibility efforts on a per-product basis. As with the measurements in 5.1, this information may be used during manufacturing as the basis for modifying manufacturing processes and procedures as well as modifying the design of the product. As shown in Figure 5.2, this data is fed back to the design guidelines team for inclusion in the design guidelines.

The third element of this step, 5.3, discusses the concept of measuring the success of an organization's producibility system as a whole and provides a starting point for that assessment. In this element, the data gathered in 5.1 and 5.2 is combined with information gathered on other products as a measure of the capability of the corporate producibility system. Also included in the assessment of 5.3 is data from the

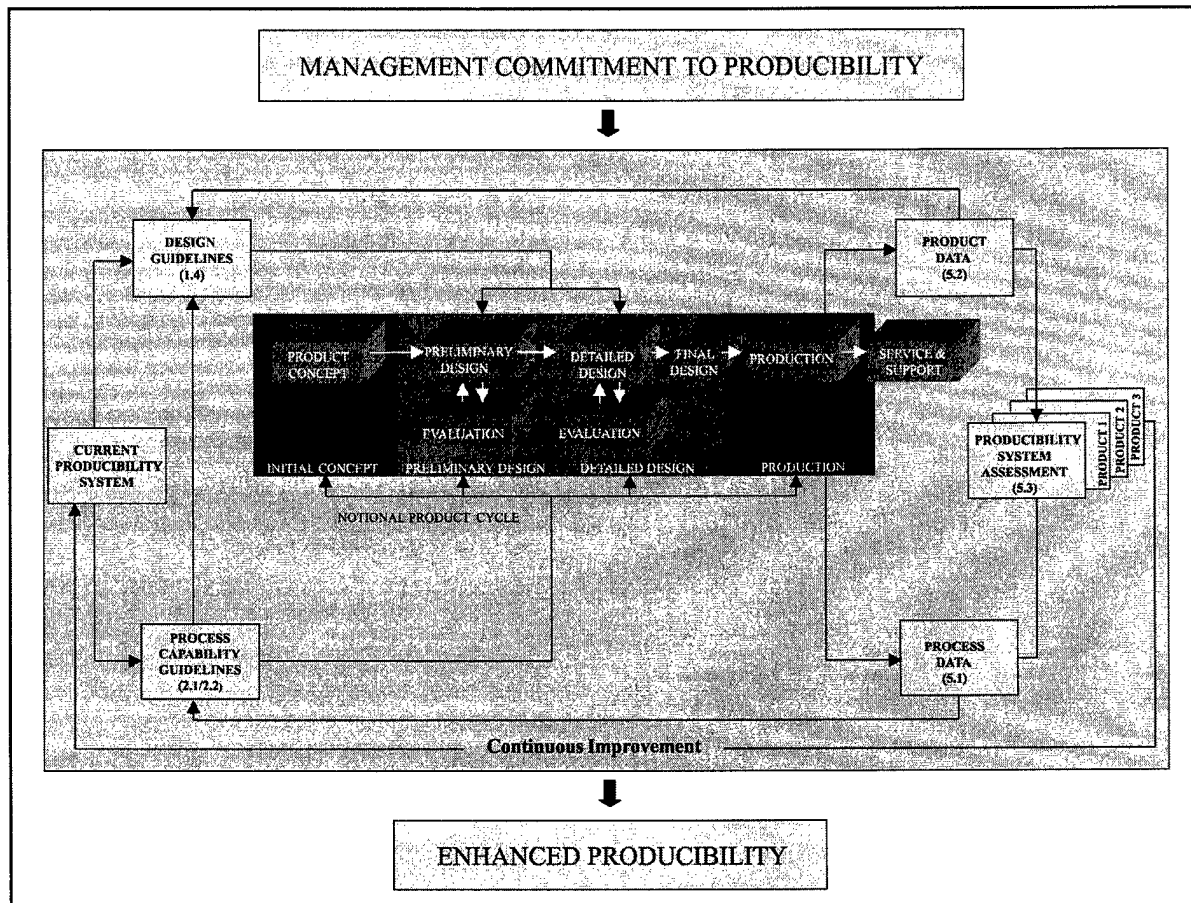

Figure 5.2 - Continuous Improvement in Producibility

benchmarking of other organization's capabilities. This assessment can be used to guide investment decisions for additional process development, equipment, and training. It is the corporate commitment to producibility that fosters this continuous improvement of its producibility system.

The three producibility system elements in measuring producibility and a corresponding key point for each are shown in Figure 5.3.

Measuring producibility must be a corporate philosophy. Senior management must continuously drive it, support it, and implement appropriate actions, identified through analysis of the data, to enhance producibility throughout the organization.

5.1. Measure Processes

Description

It is important to measure processes to understand process capabilities (Step 2) and to manufacture a

product that meets the customer's performance, cost, and schedule requirements (Steps 3 and 4). As discussed in Step 2 - Determine Process Capability, a thorough understanding of both company and supplier current process capabilities is critical to a successful producibility system. The level of process understanding required is achieved through effective process measurement and the application of the resulting data to future processing. These principles are explained in more detail in Step 2.

From a manufacturing standpoint, variability reduction is the goal of process measurement. Process variability results in variations in product. Effective process measurement, data analysis, and process adjustments ensure that processes are controlled and variability is either minimal or tolerable within the limits of the design. Rework is reduced; scrap is virtually eliminated; and, quite possibly, downstream product inspection requirements can be relaxed or eliminated. In short, products can be affordably

manufactured to meet Six Sigma or other designated quality goals.

Improvements in producibility require that the knowledge gained from process measurements is used to more thoroughly understand and refine or optimize processes so that future products can be produced more accurately, more cost-effectively, or more quickly. The data from process measurements must be

used to improve the process so that affordable, high quality products result each and every time.

To effectively assess processes, proper process metrics must be defined. Process metrics typically compare current process performance against objectives based on historical data, extrapolations from historical data for similar products, or predictions resulting from efforts such as process simulations. The process is then measured using the metrics, and the data is analyzed to ensure that the objectives for the process are being met. Analysis of deviations from expected results helps to identify process refinements that may be necessary to meet the defined objectives or highlights changes to the objectives that may be required.

Both process and product measurements are critical to ensure that the product meets the appropriate quality requirements. Hence, the activities that are performed as part of this producibility element during product manufacture are closely associated to the activities that are performed as part of 5.2 - Measure Products.

Examples detailing the importance of measuring and controlling manufacturing processes to impact product producibility are presented in Case Studies 42 and 43 in Appendix D.

Significance

Process measurements are necessary to understand process capabilities and to control process variation so that high quality products that meet the customer's requirements can be manufactured repeatedly and affordably.

Resource Requirements

Staff: Typically, production personnel perform process measurements and, in many cases, analyze the data and perform corrective action. The overall effort, however, should be coordinated by process

Producibility System Element	Key Point
5.1 Measure Processes	Obtain data for understanding of process capabilities. Control processes to reduce process variation.
5.2 Measure Products	Measure products to verify that products meet customer's quality, schedule, and cost requirements.
5.3 Measure Producibility System	Assess success of producibility efforts by evaluating producibility on a per-product basis. Benchmark against world-class companies. Strive for continuous improvement.

Figure 5.3 - Key Points of Step 5 - Measure Producibility

control experts working in concert with the corporate process capabilities team discussed in 2.1.

Tools and Techniques: There are many tools and techniques to measure processes – techniques to ensure that process variability is controlled and techniques to identify possible corrective action for processes in trouble. Many of these tools and techniques were discussed in Step 2. Techniques that target variability reduction as their goal include Six Sigma and Statistical Process Control (SPC). Techniques helpful in identifying inherent problems or inflexibility in processes and determining possible corrective steps include Design of Experiments (DOE), Process Failure Mode and Effects Analysis (PFMEA), and Root Cause Analysis (RCA). Depending on the chosen method for process capability guidelines (as discussed in 2.1), required tools for the collection and analysis of process measurement data might include web-based software or a Database Management System. These tools and the appendix in which they are discussed are highlighted in Figure 5.4.

Training: Many of the tools and techniques commonly used to measure processes are not self-explanatory, and although not required, training on the effective use of the tools and techniques is recommended. Due to the importance of variability reduction to the overall producibility efforts, training on Six Sigma and SPC is particularly encouraged.

Implementation

Senior management must drive the corporate commitment to producibility measurement. Typically, a senior level manager or corporate vice president maintains producibility as an overall responsibility and tracks progress against goals.

Tools and Techniques	Appendix
• Database Management Systems	F.1.3
• Design of Experiments (DOE)	F.1.6
• Process Failure Mode & Effects Analysis (PFMEA)	F.1.7
• Root Cause Analysis	F.1.19
• Six Sigma	F.1.20
• Statistical Process Control (SPC)	F.1.21

Figure 5.4 - Tools and Techniques for Measuring Processes

Process measurements typically are made by production staff either during process studies or during the manufacture of product. During the manufacture of a particular product, process measurement results may be analyzed and appropriate action taken by the production staff with approval from the cognizant product manager or product quality engineer. As shown in Figure 5.3, this data should be forwarded to the process capabilities team for analysis, tracking, action plan development and implementation (if appropriate), as well as incorporation into the process capability guidelines (2.1). Basic steps in measuring processes are:

1. Identify goals and purpose of measurements.
2. Develop appropriate metrics.
3. Select appropriate measurement tools and techniques (such as Statistical Process Control).
4. Measure and collect data at appropriate checkpoints in the process.
5. Analyze data. If process measurement is related to a product, inform IPT for tracking and determination of action items.
6. Measure progress against goals. Display progress.
7. Initiate process improvement activities if required.
8. Assess validity of metrics and update if necessary.
9. Forward results of process measurements to process capabilities team for incorporation into the process capability guidelines (2.1).

5.2. Measure Products

Description

Products must meet the customer's performance, cost, and schedule requirements. Based on these requirements, product goals are defined by the IPT in 3.1. Goals must be well documented so that a

comparison of goals to actuals can be performed to assess product producibility and to provide continuous feedback and enable improvement.

In addition to customer-driven goals, most organizations have internal goals, such as reducing the manufacturing cost of all products by 10 percent to increase the profit margin or reducing machine downtime by 15 percent. These must also be considered by the IPT when developing the producibility goals and metrics for the product.

Producibility goals should be specific and measurable. Examples might be the maximum number of defects per unit product or the maximum internal cost of manufacturing for the product.

Types of product measurements vary widely from product to product and from industry to industry. What to measure depends on the product itself and internal as well as customer requirements. Each product IPT, in concert with the corporate strategy and guidelines, must determine what is important to measure and establish appropriate metrics. Examples of product measurements commonly used to assess quality, cost, and schedule include, but are not limited to:

Quality: C_p , C_{pk} , DPU, dpmo*, rework, scrap, yield

Cost: Cost (of products, components, materials, processes, etc.)

Schedule: Cycle time, lead time, deliveries to schedule

*The Acronyms C_p , C_{pk} , DPU, and dpmo can be found in Appendix A.

Examples of other product measurements that impact producibility include:

Technical Risk: Number of new parts, new vendors, new processes

Design: ECNs, ECPs*

Complexity: Number of parts, processes, tools, features, and characteristics

*The Acronyms ECN and ECP can be found in Appendix A.

To assess the producibility of the product, the IPT analyzes the product data for trends and identifies any necessary corrective actions. Corrective actions could be either design or process-related. Results of these analyses are forwarded to the team or person responsible for maintaining the corporate design guidelines (discussed in 1.5) for incorporation.

Significance

Product measurements are necessary to assess whether the product meets customer-driven as well as internal goals.

Resource Requirements

Staff: Production personnel typically perform product measurements during routine product inspection steps. Quality engineers are required to oversee the measurement of the product, and the IPT analyzes data to identify trends and any necessary corrective actions.

Tools and Techniques: There are many tools and techniques to measure products. Widely used techniques that target variability reduction (both product and process) as its goal are Six Sigma and Statistical Quality Control (SQC). Techniques that are helpful in identifying inherent problems in either designs or products and determining possible corrective steps for future products are Design Failure Mode and Effects Analysis (DFMEA) and Root Cause Analysis (RCA). Depending on the chosen method for design guidelines (as discussed in 1.5), required tools for collection and analysis of product measurement data might include web-based software or a database management system. These tools and the appendix in which they are discussed are highlighted in Figure 5.5.

Training: Training on the use of Six Sigma and SQC is highly recommended. Training on Database Management Systems, DFMEA, Root Cause Analysis, and Tolerance Analysis is useful but not required.

Implementation

Senior management must drive the corporate commitment to producibility measurement. Typically, a senior level manager or corporate vice president maintains producibility as an overall responsibility and tracks progress against goals for all products.

Tools and Techniques	Appendix
• Database Management Systems	F.1.3
• Design Failure Mode & Effect Analysis (DFMEA)	F.1.7
• Root Cause Analysis	F.1.19
• Six Sigma	F.1.20
• Statistical Quality Control (SQC)	F.1.22
• Tolerance Analysis	F.1.23

Figure 5.5 - Tools and Techniques for Measuring Products

Product-specific IPTs are responsible for identifying the product measurement metrics required to effectively assess whether product goals have been met. Much of this information is collected during various inspection procedures performed as the product goes through the manufacturing cycle. The data, however, must be analyzed by the IPT to compare against the goals established in 3.1 to ensure that the product meets customer as well as any internal requirements. Analysis of this data is also helpful in identifying trends that require corrective action. Basic steps in product measurement include:

1. Set goals from customer requirements (3.1) as well as internal considerations. Document.
2. Establish appropriate metrics from customer and internal goals.
3. Measure product.
4. Analyze data. Compare actuals to goals to determine whether product meets customer goals as well as producibility goals. Display progress towards goals.
5. Identify trends and corrective action if necessary.
6. Address validity of goals and metrics and update if required.
7. Forward product measurement information to individual or team responsible for design guidelines to incorporate, if appropriate.

5.3. Measure Producibility System

Description

The effectiveness of an organization's producibility system must be measured. This assessment is helpful in identifying areas for improvement and in planning the implementation of new producibility methods. It guides investment decisions for additional process development, equipment, and training. Continuous improvement in enhancing producibility should be the goal.

Measurement of the success of a producibility system, however, is not a simple task. There are no set rules that each organization can apply. Organizations and their approaches to producibility are very different – even within the same industry. Each organization must determine its goals in producibility and, from these goals, the characteristics of its producibility system that must be measured to obtain an accurate assessment of overall producibility. These goals include customer-driven goals as well as inter-

nal goals. Progress towards meeting the goals must be continuously evaluated and producibility achievements communicated to the company staff and its customers. Producibility enhancements must be celebrated.

In general, to assess producibility performance on a corporate level, an organization must first evaluate its producibility performance on a product-by-product basis. Product-specific producibility assessments are determined from the information collected as part of 5.1 and 5.2. An analysis of the producibility performance against all products serves as a good indicator of the success of an organization's overall producibility approach.

A second gauge of producibility system performance is IPT performance. Corporate management should focus the IPTs on setting aggressive, but realistic, producibility goals and strongly encourage the IPTs to meet them. Measuring the IPTs' performance to goals across the enterprise gives an indication whether management has emphasized the importance of producibility in all of its efforts clearly enough and empowered the IPTs to achieve their respective goals.

Often, valuable information regarding the direction in which a company might want to go with its producibility efforts is gained by benchmarking. The organization should evaluate the competition and other successful companies to determine best-in-class producibility approaches, techniques, and goals and should implement a practice of "innovative imitation" – that is, to incorporate and then improve on those best ideas and methods that will provide desired benefits to producibility.

Significance

To continuously improve in its producibility efforts, an organization must assess its performance against its producibility goals. This evaluation helps in identifying future efforts required to enhance producibility.

Resource Requirements

Staff: Senior management drives the corporate commitment to producibility and its continuous improvement. The responsibility of overall company producibility typically belongs to a senior level manager or corporate vice president who tracks corporate progress against goals.

Tools and Techniques: Evaluating the producibility approaches and techniques used by

other companies can be accomplished by Benchmarking. Depending on the chosen method for cataloging producibility information, required tools might include a Database Management System or Knowledge-Based System, with Decision Support Tools, if necessary. These tools and the appendix in which they are discussed are highlighted in Figure 5.6.

Training: Training on Database Management Systems, Knowledge-Based Systems, and Decision Support Tools would be recommended, but not required.

Tools and Techniques	Appendix
• Benchmarking	F.1.1
• Database Management Systems	F.1.3
• Decision Support Tools	F.1.4
• Knowledge-Based Systems	F.1.10

Figure 5.6 - Tools and Techniques for Measuring Producibility Systems

Implementation

Corporate management must continuously demonstrate its commitment to producibility and its continuous improvement. Typically, a senior level manager or corporate vice president is responsible for tracking company-wide producibility. However, the responsibility of meeting producibility goals and the rewards for doing so belong to all employees.

Basic steps in measuring the effectiveness of a company's producibility system include:

1. Identify enterprise-wide producibility goals and metrics.
2. Collect producibility performance data for products.
3. Measure IPTs' performance to their respective goals.
4. Analyze data to identify trends and possible course of action for enterprise-wide producibility improvement.
5. Assess validity of goals and metrics. Update if necessary.
6. Benchmark the competition and other leading companies to identify best-in-class producibility approaches, techniques, and goals.
7. Communicate successes and progress towards goals to company staff and customers.
8. Continuously evaluate producibility performance.

CONCLUSION

The enhancement of producibility in a commercial or defense enterprise can result in more satisfied customers and increased profitability. The guidelines that have been presented in this document are intended to provide assistance for achieving that enhancement. An attempt has been made to provide a brief, simple, accurate overview of each item discussed. The intent is to give the producibility novice, the producibility expert, and everyone in between a useful reference tool.

Producibility, as defined by the PTF, is "the relative ease by which a product can be manufactured as measured in yield, cycle times, and the associated costs of options in product designs, manufacturing processes, production and support systems, and tooling." Each of the five producibility steps, as well as the producibility system elements within those steps, have been presented here in enough detail and with sufficient references so that the underlying techniques for improving producibility can be understood and further explored. Whenever possible, case study examples and overview descriptions of tools and techniques have been provided. Also, a series of three matrices for an organization to self-assess its level of producibility development has been included in the Introduction to assist in identifying and prioritizing areas for producibility investment.

As defined by the PTF, a producibility system is "the integrated process and resources needed to successfully achieve producibility." The intent has been to provide the reader with the basic concepts needed to develop and continuously improve an effective producibility system. To do so does not require

that all the elements of every step be implemented. What is required is an understanding of the elements and the steps and their relationship to each other and to the specific enterprise whose producibility system is being developed and improved.

The subject of producibility continues to improve and change as various companies from various industries apply techniques such as these, modify them, and thereby improve the state-of-the-art. Hence, it is impossible to ensure completeness in any one document. These guidelines represent the PTF's judgment of the key considerations applicable to a wide range of manufacturing enterprises. The techniques and processes described herein are not meant to be rigidly applied. Taken together, they provide a useful, sufficiently complete guide to assist in improving producibility.

Throughout this document, the use of an Integrated Product Team (IPT), which includes representatives of all the key functions of the enterprise and its customers and suppliers, has been encouraged. It has been demonstrated that an IPT, with the primary responsibility for implementing all essential elements of producibility during design, development, and production, can ensure that the tools for controlling processes and for understanding the causes for, and solutions to, unacceptable product and process variability are implemented.

The key is management commitment. The five steps are the building blocks. The application must be adapted to each enterprise based on its products and its culture. The results can be impressive.

Appendix A

TABLE OF ACRONYMS

Acronym	Definition
ABC	Activity-Based Costing
AWC	Arithmetic Worse Case
BMP	Best Manufacturing Practices
BTP	Build-to Package
CAD	Computer Aided Design
CAIV	Cost As an Independent Variable
CCA	Circuit Card Assembly
CDR	Critical Design Review
C _i	Capability Index
C _{pk}	Capability Index (Shifted)
DFA	Design for Assembly
DFC	Design-for-Cost
DFM	Design for Manufacture
DFMA	Design for Manufacture/Assembly
DFMEA	Design Failure Mode and Effects Analysis
DMS	Diminishing Manufacturing Sources
DoD	Department of Defense
DOE	Design of Experiments
dpmo	Defects per million opportunities
DPU	Defects Per Unit
DRSS	Dynamic Root Sum of Squares
DTC	Design-to-Cost
E-CAD	Electronic Computer Aided Design
ECN	Engineering Change Notice
ECP	Engineering Change Proposal
EDM	Electronic Data Management
EMI	Electromagnetic Interference
ERP	Enterprise Resource Planning
FMEA	Failure Mode and Effects Analysis
FOD	Foreign Object Damage
GAO	General Accounting Office
GPS	Global Positioning System
GPSIS	Global Positioning System Inclinometer System
HARM	High Speed Anti-Radiation Missile
I/O	Input/Output
IPDDB	Integrated Product Definition Data Base
IPPD	Integrated Product and Process Development
IPT	Integrated Product Team
ISO	International Standards Organization

Acronym	Definition
JCALs	Joint Continued Acquisition and Logistics Support
KPAT	Knowledge-Aided Producibility Analysis Technique
KSAT	Knowledge-Aided Supportability Analysis
LAVAD	Light Armored Vehicle Air Defense
LCC	Life-Cycle Cost
LRAS3	Long Range Advanced Scout Surveillance System
MES	Manufacturing Execution Systems
MRP	Material Requirements Planning
MRP II	Manufacturing Resource Planning
MS	Microsoft
MSN	Manufacturer Serial Number
OC	Operating Characteristics
PAW	Producibility Assessment Worksheet
PCA	Process Capability Analysis
PCM	Process Capability Model
PDR	Preliminary Design Review
PDTR	Producibility Design-to Requirements
PFMEA	Process Failure Mode and Effects Analysis
PMT	Performance Management Team
PRR	Production Readiness Review
PTF	Producibility Task Force
QFD	Quality Function Deployment
RCA	Root Cause Analysis
RFI	Radio Frequency Interference
RPN	Risk Priority Number
RSS	Root Sum of Squares
SCRAM	Schedule/Cost Risk Analysis Module
SDTR	Supportability Design-to Requirements
SLA	Stereolithography Apparatus
SLS	Selective Laser Sintering
SPC	Statistical Process Control
SQC	Statistical Quality Control
SQL	Structured Query Language
SRR	Systems Requirements Review
SRSS	Static Root Sum of Squares
TDP	Technical Data Package
TQM	Total Quality Management
TRIMS	Technical Risk Identification and Mitigation System
UV	Ultraviolet
WBS	Work Breakdown Structure
WUC	Work Unit Code

Appendix B

GLOSSARY OF PRODUCIBILITY TERMS

The following terms used in this guidelines document are defined as they apply to producibility. Although most of these terms appear in the text, others are alluded to or have a bearing on the understanding of producibility. Sources for these definitions include the Defense Systems Management College, Department of Defense Specifications, and the Producibility Task Force members.

Benchmarking: A process of comparing and evaluating products or processes in order to identify best practices and/or opportunities for improvement.

Complexity Analysis: An activity used to assess and simplify the product / manufacturing plan to minimize cost and schedule issues.

Cost Tools: Techniques for evaluating, managing and controlling the costs associated with product development.

Critical Design Review (CDR): A review conducted to determine that the detailed design satisfies the performance and engineering requirements of the development specification; to establish the detailed design compatibility among the item and other items such as equipment, facilities, computer programs, and personnel; to assess producibility and risk areas; and to review the preliminary product specifications.

Database Management System: A computer-based system that facilitates the creation, maintenance, and access to a database.

Decision Support Tools: Tools, usually computer-based, that are used to organize and communicate information used for decision-making.

Defect: Any variation in a required characteristic of a product or its parts which is far enough removed from its target value to prevent the product from fulfilling the physical and/or functional requirements of the customer or specification.

Defects per million opportunities (dpmo): A measure of process capability that normalizes defects per unit data so as to provide an equivalent comparison of processes, products, and services.

Defects Per Unit (DPU): A ratio of the number of defects found at any acceptance point to the number of units submitted. All reworked items undergoing inspection and test are excluded from the calculation.

Design Failure Mode and Effects Analysis (DFMEA): A technique used to analyze, prior to entering the manufacturing phase of development, a part's design to identify potential failures, errors, and defects and their effect on cost and risk.

Design for Manufacture / Assembly (DFMA): A technique used to achieve the optimum balance between design objectives, manufacturing and assembly requirements, and process capabilities.

Design Guidelines: Design guidelines are a compilation of knowledge expressed either in hard copy or electronic media that may be used by the design engineer or the Integrated Product Team to design the product to optimize its producibility.

Design of Experiments (DOE): The application of statistical tools and techniques as a means of optimizing product design and manufacturing processes.

Design Parameters: Qualitative, quantitative, physical, and functional value characteristics that are inputs to the design process for use in tradeoff studies, risk analyses, and the overall development of a product that meets customer requirements.

Error-Proofed Design: Design for which the design team or Integrated Product Team has considered ways to eliminate or reduce the occurrence of failure from mistakes during the manufacturing, assembly, and maintenance processes.

Failure Mode and Effects Analysis (FMEA): A technique used to identify the cause of failures, errors, and defects and to develop a corrective plan of action.

Integrated Product and Process Development (IPPD): A design practice, accomplished through the use of multi-disciplinary teams, that emphasizes the development of manufacturing processes concurrently with the development of a product.

Integrated Product Team (IPT): An empowered, multi-disciplinary team that is responsible for the product development; often used as part of Integrated Product and Process Development.

Key Characteristics: Those product attributes that have the greatest impact on product performance, and manufacturing time, cost, and schedule.

Knowledge-Based System: A computer-based system used to document and disseminate human expertise and other documented knowledge.

Life-Cycle Cost (LCC): The total cost for development, operation, maintenance, and disposal of a product over its full life and a value that is often used in design tradeoff studies. A model can be used to optimize product costs and predict future costs of maintenance, logistics, and warranties.

Manufacturing Planning Tools: Techniques that aid organizations with integrating manufacturing planning into the product development cycle and with other business planning functions.

Manufacturing Simulation: A mathematical modeling, usually coupled with a graphical representation, of a new or existing manufacturing operation and performed to identify opportunities for improvement or optimization.

Modeling and Simulation: The mathematical, physical, or graphical representation of a product or system on which analytical experiments may be conducted.

Multi-Disciplinary Team: A team with representatives from all organizational elements relevant to the successful development of a product (i.e., design, manufacturing, production, quality, marketing, etc.) (see Integrated Product Team).

Pareto Analysis: A method, using vertical bar graphs, to display occurrences in a prioritized order. Occurrences are taken for a specific time-frame of the event measured.

Preliminary Design Review (PDR): A review conducted on each configuration item to evaluate the progress, technical adequacy, and risk resolution of the selected design approach; to determine its compatibility with performance and engineering requirements of the development specification; and to establish the existence and compatibility of the physical and functional interfaces among the item and other items such as equipment, facilities, computer programs, and personnel.

Process Capability Guidelines: A reference source that provides the designer or manufacturing engineer with information about the organization's process capabilities, including equipment, facilities, and materials.

Process Failure Mode and Effects Analysis (PFMEA): A means for analyzing manufacturing processes to identify potential problems that may induce part defects.

Process Simulation: A simulation that typically focuses on the precise physical behavior of a particular manufacturing process.

Producibility: The relative ease by which a product can be manufactured. Relative ease is measured in yield, cycle times, and the associated costs of options in product designs, manufacturing processes, production and support systems, and tooling.

Producibility Assessment Worksheet (PAW): Documented expert opinion that is used as a means of identifying potential problem areas related to the producibility of a product.

Producibility System: The integrated process and resources needed to successfully achieve producibility.

Production Readiness Review (PRR): A formal review of a program to determine if the design is ready for production, if production engineering problems have been resolved, and if the producer has accomplished adequate planning for the production phase.

Prototyping: Representation of a product or process used to determine form-fit-and-function qualities and requirements.

Quality Function Deployment (QFD): An iterative process used to identify and define customer requirements and their effects on the design attributes.

Rapid Prototyping: A process for quickly transforming a design into a three-dimensional, physical model.

Risk Management Tools: Tools used to identify, assess, and mitigate the risks associated with product development.

Root Cause Analysis (RCA): A technique used to identify and eliminate the sources of failures and problems.

Sigma: The Greek letter used to denote the standard deviation of the normal distribution. The standard deviation is a measure of the dispersion of the data.

Six Sigma: A quality approach used to obtain zero defects in production.

Statistical Process Control (SPC): The use of statistical tools and techniques to identify, analyze, and control variation in manufacturing processes.

Statistical Quality Control (SQC): The use of statistical methods to analyze, monitor, and control the quality of the product and the production processes.

Systems Requirement Review (SRR): A Systems Requirement Review is conducted to ascertain progress in defining system technical requirements. It helps users determine the direction and progress of the systems engineering effort and the degree of convergence upon a balanced and complete configuration. A Systems Requirement Review with the customer focuses identification of and concurrence on the systems requirements and specifications to ensure they are clear, concise, accurate, and verifiable.

Tolerance Analysis: Tolerance analysis is a study of the deviation from nominal specifications that a component may have and still satisfy quality requirements.

Trade Study or Tradeoff Analysis: A formal decision-making method that can be used to solve many complex problems. Used in producibility to rank potential design solutions against the product goals to highlight the manufacturing advantages and disadvantages of each design concept.

Appendix C

BIBLIOGRAPHY

- Allen, Thomas J. Managing the Flow of Technology. Cambridge: Massachusetts Institute of Technology Press, 1977.
- American Institute of Aeronautics and Astronautics. Recommended Practice for Parts Management: AIAA R-100-1996. Reston, VA: American Institute of Aeronautics and Astronautics, 1997.
- Amsden, Robert T., Howard E. Butler, and Davida M. Amsden. SPC Simplified: Practical Steps to Quality. White Plains, NY: Quality Resources, 1986.
- Aubrey, Charles A., II, and Patricia K. Felkins. Teamwork: Involving People in Quality and Productivity Improvement. Milwaukee: Quality Resources, 1988.
- Boothroyd, Geoffrey, and Peter Dewhurst. Product Design for Assembly. Wakefield, RI: Boothroyd Dewhurst Inc., 1989.
- Boothroyd, Geoffrey, Peter Dewhurst, and Winston Knight. "Estimating the Costs of Printed Circuit Assemblies." Printed Circuit Design. June 1989.
- Bothe, Davis R. Measuring Process Capability. New York: McGraw-Hill Companies, 1997.
- Bralla, James, ed. Handbook of Product Design for Manufacturing. New York: McGraw-Hill Companies, 1986.
- Bralla, James. Design for Excellence. New York: McGraw-Hill Companies, 1995.
- Cooper, Robin, and Regine Slagmulder. Target Costing and Value Engineering. Portland, OR: Productivity Press, 1997.
- Creveling, Clyde M. Tolerance Design: A Handbook for Developing Optimal Specifications. Reading, MA: Addison-Wesley Publishing, 1996.
- Deming, W. Edwards. Out of the Crisis. Cambridge: Massachusetts Institute of Technology, Center for Advanced Educational Services, 1986.
- Dorofee, Audrey J., et al. Continuous Risk Management Guidebook. Pittsburgh: Software Engineering Institute, 1996.
- Electronic Industries Association. Process for Engineering a System: Interim Standard 632. Arlington, VA: Electronic Industries Association, 1994.
- Gebala, D. Letter. Motorola, Advanced Manufacturing Technologies. Fort Lauderdale, FL. 6 August 1992.
- Harry, Mikel J., and Ronald Lawson. Six Sigma Producibility Analysis and Process Characterization. Reading, MA: Addison Wesley Longman, 1992.
- Hinckley, C. Martin. A Global Conformance Quality Model: A New Strategic Tool for Minimizing Defects Caused by Variation, Error, and Complexity. Dissertation. Stanford University, 1993. UMI/NTIS SAND94-8451, 1994.

-
- Ishikawa, Kaoru. Guide to Quality Control. Tokyo: Asian Productivity Organization, 1982.
- James Gregory Associates. Affordability in Science and Technology: An Introduction. Pickerington, OH: James Gregory Associates, 1998.
- Knight, M. "Trends in the Automotive Industry to Lower Life Cycle Costs." Report. University of Texas at Arlington, 1995.
- Lamm, John. "Ethos-Orbital Prototype." Road and Track. April 1993: 126.
- Large, J. P., H. G. Campbell, and D. Cates. Parametric Equations for Estimating Aircraft Airframe Costs. Santa Monica, CA: Rand Corporation, 1976.
- Larson, Erik W., and David H. Gobeli. "Organizing for Product Development Projects." Journal of Product Innovation Management 5.3 (1988): 180-190.
- Nikkan Kogyo Shimibun, and Factory Magazine, eds. Poka-Yoke: Improving Product Quality by Preventing Defects. Portland, OR: Productivity Press, 1989.
- Norman, Donald A. The Design of Everyday Things. New York: Doubleday, 1990.
- Pioneer Manufacturing. Producibility Program Plan Outline. Flagstaff, AZ: Pioneer Manufacturing, 1997.
- Priest, John W. Engineering Design for Producibility and Reliability. New York: Marcel Dekker, 1988.
- Reason, James. Human Error. New York: Cambridge University Press, 1990.
- ReVelle, Jack B. The Two Day Statistician: An Introduction to Statistical Quality Control. Los Angeles: Hughes Aircraft Company, 1988.
- Schroeder, Don. "The Run-Flat Eagle Tire." Car and Driver. February 1994: 95-96.
- Seldon, M. R. Estimating the Cost of R and M Changes. Proceedings of the Annual Reliability and Maintainability Symposium. San Francisco, 1980. New York: Institute of Electrical and Electronics Engineers, 1980.
- Shewhart, Walter A. Economic Control of Quality of Manufactured Product. New York: Van Nostrand, 1931.
- Shingo, Shigeo. Zero Quality Control: Source Inspection and the Poka-Yoke System. Stamford, CT: Productivity Press, 1986.
- Smith, Preston G., and Donald G. Reinertsen. Developing Products in Half the Time. New York: John Wiley & Sons, 1991.
- Stamatis, Dean H. Failure Mode and Effect Analysis. Milwaukee: ASQ Quality Press, 1995.
- Tandom, Mridul K., and Ali A. Seireg. Manufacturing Tolerance Design for Optimum Life-Cycle Cost. Proceedings of Manufacturing International. Dallas, 1992. New York: American Society of Mechanical Engineers, 1992.
- Texas Instruments. What is Six Sigma?. Dallas: Texas Instruments, 1992.

United States. Department of Defense. Defense Systems Management College. Cost as an Independent Variable Workshop. Fort Belvoir, VA: Defense Systems Management College, 1998.

United States. Department of the Air Force. Air Force Materiel Command. Risk Management: AFMCPAM 63-101. Washington, DC: Air Force Materiel Command, 1997.

United States. Department of the Navy. Office of the Assistant Secretary of the Navy (Research, Development, & Acquisition). Methods and Metrics for Product Success. Washington, DC: Office of the Assistant Secretary of the Navy (Research, Development, & Acquisition), 1994.

United States. Department of the Navy. Best Manufacturing Practices Center of Excellence. Producibility Measurement for DOD Contracts. Washington, DC: Best Manufacturing Practices Center of Excellence, 1990.

United States. Department of the Navy. Best Manufacturing Practices Center of Excellence. Producibility Measurement Guidelines: NAVSO P-3679. Washington, DC: Best Manufacturing Practices Center of Excellence, 1993.

United States. Department of Transportation. Federal Aviation Administration. The Human Factors Guide for Aviation Maintenance. Washington, DC: Government Printing Office, 1996.

United States. National Academy of Sciences. National Research Council. Unit Manufacturing Processes: Issues and Opportunities in Research. Washington, DC: National Research Council, 1995.

Voigt, Edward C., ed., and Takashi Ichida, compiler. Product Design Review: A Method for Error Free Product Development. Portland, OR: Productivity Press, 1996.

Womack, James P., and Daniel T. Jones. Lean Thinking. New York: Simon & Schuster Trade, 1996.

Womack, James P., Daniel T. Jones, and Daniel Roos. The Machine That Changed the World. New York: Macmillan Publishing, 1990.

Appendix D

CASE STUDIES

The following case studies serve as examples of the producibility principles presented in this guidelines document. These case studies have differing origins and different formats. Some are validated Best Practices identified through Best Manufacturing Practices program surveys. These are marked with the Best Practices seal. Others were submitted by various companies throughout the United States. All, however, illustrate how producibility principles can be applied effectively.

The producibility elements that the case studies support have been identified and are shown below in Figure D.1. In those instances where a case study supports more than one producibility element, primary support is indicated by a "P" and secondary support by an "S."

Case Study	Producibility Steps and Elements																Appendix			
	Infrastructure						Process Capab	Conceptual Design				Final Design	Measurement							
	1.1 Mgmt Commitment	1.2 Organize for Prod	1.3 Risk Mgmt Program	1.4 New Product Intro Strategy	1.5 Prod Design Guidelines	1.6 Commercial Best Practices	2.1 Current Capabilities	2.2 Future Capabilities	3.1 Product Goals	3.2 Key Characteristics	3.3 Trade Studies	3.4 Manufacturing Plan	3.5 Complexity Analysis	4.1 Prod Eng Review	4.2 Error-Proof Design	4.3 Optimize Manufacturing		5.1 Measure Processes	5.2 Measure Products	5.3 Measure Prod System
1. Integrated Product Development I	P	S																		D.1
2. Integrated Product Development II	P	S																		D.2
3. Integrated Product Development III	P	S																		D.3
4. Integrated Product Development IV	P	S																		D.4
5. Performance Management Teams		P															S			D.5
6. Integrated Product Teams	S	P																		D.6
7. Risk Management I			P																	D.7
8. Risk Management II			P																	D.8
9. Risk Management III			P																	D.9
10. Program Launch Process	S		S	P																D.10
11. Knowledge / Rule-Based Guidelines					P															D.11
12. Mechanical Design Guidelines					P															D.12
13. Benchmarking Process						P														D.13
14. Benchmarking as a Tool for Quality Assessment						P														D.14
15. Best Practices Program						P														D.15
16. Supplier Best Practices						P														D.16
17. Process Capability Analysis							P			S				S						D.17
18. Process Capability Models							P			S										D.18
19. Understanding Composites and their Processing Requirements			S				P													D.19
20. Machine Capabilities and Tolerances							P													D.20
21. Partnering with Suppliers		S					P													D.21
22. Manufacturing Technology Insertion		S	S	S			S	P												D.22
23. Obsolescence and Commercial Technology Insertion								P												D.23
24. Affordability as a Key Product Goal									P		S									D.24
25. Design-to-Cost I									P	S										D.25
26. Design-to-Cost II									P											D.26
27. Application of Quality Function Deployment to Battery Design									P	P										D.27
28. Key Characteristics and Variability Reduction										P										D.28
29. F-22 Variability Reduction										P						S				D.29
30. Design for Manufacture/Assembly in Concurrent Engineering	S										P									D.30
31. Power Supply Trade Study											P									D.31
32. System Engineering Trade Study											P									D.32
33. Variation Simulation Analysis											P									D.33
34. Aircraft Panel Complexity Analysis													P							D.34
35. Change in Design Tolerance Due to Complexity Analysis Results											S		P							D.35
36. Complexity Analysis Examples													P							D.36
37. Producibility Expert Program		S												P						D.37
38. Producibility Review in Product Manufacture														P						D.38
39. Poka-Yoke: Mistake-Proofing the Process														P						D.39
40. Modeling and Simulation															P					D.40
41. Factory Process Modeling and Simulation							S			S					P					D.41
42. Process Variability Reduction							P									P				D.42
43. Using Metrics to Drive Process and Quality Management							P									P				D.43

Figure D.1 - Case Studies vs. Producibility Elements

D.1. Case Study 1 - Integrated Product Development I



Producibility Elements Highlighted:

Primary: 1.1 Recognize the Need for Management Commitment

Secondary: 1.2 Organize for Producibility

Market competition, driving the need to improve quality, reduce cost, and shorten cycle times, prompted McDonnell Douglas Aerospace (MDA) - West (Boeing Space Systems) to aggressively pursue concurrent engineering. While MDA has practiced concurrent engineering over the years, top corporate management recently re-emphasized its policy to build the product right the first time, every time. This re-emphasis, coupled with integrated CAD/CAM systems, provided a supportive environment for concurrent engineering (CE). Management demonstrated the backing of its policies through organizational restructuring, and the company has moved away from functional organizations toward Integrated Product Development (IPD) teams that operate in a flexible matrix. IPD multi-functional teams provide the communications interaction foundation for concurrent engineering efforts at MDA. The teams are augmented with integrated design and manufacturing support systems that create the environment for near real-time concurrent engineering. IPD efforts focus on eliminating functional communication barriers or "silos." As a result, IPD provides the framework for MDA's concurrent engineering efforts. This effort is a holistic, systematic approach encompassing the entire life-cycle development effort from concept through disposal.

CE/IPD represents a common sense approach to proceed with the right thinking up front and promote all possible parallel actions. This common sense approach to CE/IPD deployment has provided several benefits, including:

- Increased efficiency through early up-front communications;
- Awareness of downstream needs of all;
- Enterprise product ownership because of team involvement;
- Reduction in non-value added activity;
- Establishment of contact networks between suppliers and teammates;
- Higher first-time quality in all program phases;
- Increased use of shared data;
- Reduction in part counts through robust design principles;
- Higher performance achieved on schedule with less rework; and
- Reduced life cycle cost.

CE/IPD supports the TQM philosophy. It is a methodology, a philosophy, and a mindset that helps teams of product developers define all aspects of a product's life cycle from concept through disposal.

D.2. Case Study 2 - Integrated Product Development II



Producibility Elements Highlighted:

Primary: 1.1 Recognize the Need for Management Commitment

Secondary: 1.2 Organize for Producibility

Lockheed Martin Tactical Aircraft Systems (LMTAS) has been applying Integrated Product Development (IPD) since 1991, when an IPD team was established for the Block 50D update to the F-16. This IPD philosophy teams functional disciplines to integrate and concurrently apply processes to produce an effective, efficient product that satisfies a customer's needs, and it requires a strong partnership among contractor, customers, and suppliers.

At LMTAS, Business Area Managers or Program Directors/Managers identify program-unique procedures and processes required for IPD, and prepare and document IPD implementation and management plans. They work with the affected functional organizations to determine team tasks and coordinate team and functional

organization plans and schedules to support accomplishment of these tasks. They appoint team leaders and IPD teams, empower team leaders and teams to meet tasking to allocated budgets and schedules required to meet customer requirements and business objectives. The Program Director/Manager, team leaders, and team members monitor accomplishments as they relate to the team plan, and provide reports and status information. Functional Organizations develop departmental plans and procedures for implementing IPD in support of Business Area/program requirements. They assign and empower personnel to meet program requirements, and develop, maintain, and provide technical expertise and functional processes that support IPD. The IPD team develops a team plan, and the team leader ensures that the plan describes the operational concepts, required resources, and schedules. The Program Manager, team leader, and Functional Organizations set performance objectives, participate in the performance appraisal process, provide recommendations for training and development, and ensure that training is accomplished to achieve IPD goals.

At LMTAS, IPD supports a wide spectrum of programs – from small, one-of-a-kind, short duration programs to large multicompany, multiyear, complex design programs.

Some important lessons learned were realized from the IPD implementation:

- Organize IPD Teams early enough to participate in setting requirements and submitting proposals;
- Integrate customers in the IPD Team structure;
- Make suppliers members of the IPD Team as soon as the selection process is complete;
- Ensure that the functional department commits to not replace any IPD Team Member without consent of the IPD Team Leader;
- Ensure that IPD Team Members maintain a strong link to their home functional department, so they know they have a place to return when the IPD program is completed;
- Keep the number of “Management” positions to a minimum;
- Provide training for the functional departments to educate them on the benefits of IPD, interfaces with IPD, and support of IPD;
- Allow teams to make their own decisions to simplify and expedite the development process;
- Empower Team Members to make necessary decisions in their assignments;
- Give serious consideration to collocation for all full-time team members. Collocation should occur at the earliest practical phase of the program;
- Ensure open communication. Communication should span across all members of the IPD Teams, both union and non-union;
- Ensure that goals are understood by all;
- Keep the customer informed;
- Treat suppliers as Team Members and keep them informed of issues affecting them;
- Accept DPRO and government procuring agencies as a Team Member and keep them informed of meetings, reviews, and decisions;
- Redefine organization procedures and policies relative to resource allocations to support IPD teaming;
- Conduct in-process reviews to ensure everyone is working to the same ground rule;
- Allow IPD Teams to develop metrics which are meaningful to the Team and fulfill functional requirements;
- Do not allow IPD to become a new bureaucracy to replace an older bureaucracy.

D.3. Case Study 3 - Integrated Product Development III

Producibility Elements Highlighted:

Primary: 1.1 Recognize the Need for Management Commitment

Secondary: 1.2 Organize for Producibility



In the past, ITT Industries Aerospace/Communications Division (ITT A/CD) used a traditional functional matrix organization approach for its product development efforts. In 1990, the company began implementing an Integrated Product Development (IPD) process to pursue, develop, and produce all hardware, software, and systems. The IPD process is supported by top-level leadership, and enables the company to establish clear IPD process and project goals (e.g., proactive risk management, robust development, process improvement). Over the years, ITT A/CD continuously improved this process, and today uses a version known as IPD97.

IPD97 relies on two customer-focused concepts: empowered multi-disciplinary product teams and concurrent IPD processes which run from proposal start through production. The teams, known as Integrated Product Teams (IPTs), are comprised of representatives from each functional organization who can voice an opinion throughout the development and production cycles. By using IPTs, ITT A/CD eliminated the traditional method where each functional organization completed its task sequentially and passed the results to the next organization.

Management support and the integration of development and production processes help make the IPD process successful at ITT A/CD. The IPD process reduces product development cycle time, lowers overall product cost, and establishes an environment in which the employees can succeed. Since implementing the process, ITT A/CD reduced its typical product development cycle time from two-and-a-half years to just one year. In addition, the number of simultaneous ongoing programs has increased from 15 programs in 1993 to 40 programs in 1998. Other benefits include smoother transitions to production and improved quality of designs and products.

D.4. Case Study 4 - Integrated Product Development IV

Producibility Elements Highlighted:

Primary: 1.1 Recognize the Need for Management Commitment

Secondary: 1.2 Organize for Producibility



In 1994, Raytheon Missile Systems Company (RMSC) responded to increased competition and changing customer requirements by incorporating Integrated Product Development (IPD) as a way to produce higher quality products at lower costs, and in less time. The company is using a whole-systems approach to implement IPD on its existing and new programs.

RMSC began looking at IPD from four perspectives: teams/people; processes; tools; and integrated disciplines. The whole-systems approach resulted in the formation of multi-disciplined Integrated Product Teams (IPTs) that focus on the product. Processes related to product development were standardized and documented. Tools (e.g., web-based product data management system, IPT handbooks) were developed to make pertinent information available to the teams. The integrated discipline approach allowed RMSC to easily incorporate IPD into the company's organizational strategies and initiatives.

By focusing on the four perspectives, RMSC incorporated significant changes which led to the successful implementation of IPD in all programs. This concept is fully supported by RMSC management, who provides the necessary staffing and resources to execute IPD. In addition, a core group within the company provides ongoing training and guidance to IPTs on the skills and concepts related to IPD. RMSC also modified the reward system to recognize and encourage team participation. Through IPD, employees are given ownership of, and responsibility for, the success of a program.

By implementing IPD, RMSC improved its manufacturing processes and began creating robust designs. This approach allows employees to acquire the skills and knowledge to effectively manage costs, schedules, and risks. Customers and suppliers can monitor the progress of a program as well as work with RMSC personnel to efficiently resolve problems. IPD has improved internal and external communications at RMSC, and provided a positive impact on the company's ability to win new contracts.

D.5. Case Study 5 - Performance Management Teams

Producibility Elements Highlighted:

Primary: 1.2 Organize for Producibility

Secondary: 5.2 Measure Products



Lockheed Martin Electronics & Missiles Production Operations adopted the concept of Performance Management Teams (PMTs) in 1985 to continuously improve the quality and reliability of the company's products and services, reduce cost and cycle times, enhance productivity, and ensure schedule compliance to maximize customer satisfaction.

PMTs require a change in culture and total workforce commitment, and quality is designated as the top priority. Team performance is measured at the team level and achievements are recognized through rewards. Teams are comprised of a normal work group from areas such as manufacturing engineering, industrial engineering, production planning, quality engineering, technical operations, procurement, and safety. Where appropriate, customers are also members of the team.

The focus of the PMT process is the team's work area and responsibilities, similar to the company-within-a-company concept. Team leaders are designated, and support groups are made an integral and active part of the team. Teams meet once per week, review performance metrics, identify action items to improve product and services quality, and develop improvements to enhance overall efficiency. Participation is mandatory and is a major part of the performance appraisal process. Nine metrics have been established at the production floor level to include: yield, rework, scrap, audit result, cost performance, schedule/cycle time, lost time/overtime, customer satisfaction, and action items. These metrics could have a positive impact on product service quality and reliability, cost performance, productivity, safety, schedule delivery, cycle time, or customer satisfaction.

PMT recognition is based on a rewards system comprised of elements such as Team of the Month and Team of the Year designations that include an award breakfast, plaque and pins, write-ups in the in-house publication, and the Teamwork Counts Suggestion Program.

The benefits of PMTs are well documented. Lockheed Martin Electronics & Missiles has had no negative government audit findings in over six years. The company was U.S. Army Missile Command Contractor Performance Certified in 1990 and ISO 9001 certified in 1994. Production scrap and rework has been reduced over 70%, resulting in production budget under-runs. Total program cycle time has been reduced by an average of 36% on major Lockheed Martin systems, and there has been mission success on all programs.

D.6. Case Study 6 - Integrated Product Teams

Producibility Elements Highlighted:

Primary: 1.2 Organize for Producibility

Secondary: 1.1 Recognize the Need for Management Commitment



McDonnell Douglas Aerospace (MDA) (St. Louis) (Boeing Aircraft and Missiles) created its IPD program in 1992 to identify all activities and personnel required to deliver a product to internal customers and suppliers. This program represented a major shift in how project teams were identified. When MDA (St. Louis) made this management change, it contacted companies that were known to be making similar changes, and benchmarked with Texas Instruments, Ford, Martin Marietta, Northrop, and Vought.

To help implement the new management changes, MDA (St. Louis) created multi-disciplinary Integrated Product Teams for a skill-based organization. One significant change was including personnel from manufacturing (such as tool design engineers) to participate on the project team. They were collocated with design engineers and the other up-front disciplines. This move helped to initiate MDA's concurrent engineering effort.

These teams are cross-functional teams and formed with the specific purpose of delivering a specific product or service to the customer. The members are selected for their skills to complement other team members. Each team is expected to design for manufacturability and ease of assembly. One project team, responsible for updating an aircraft design, has been able to reduce the number of parts required by 33% on schedule, on cost, and has eliminated 11,000 defects per aircraft.

To prepare personnel to participate on these project teams, MDA (St. Louis) instituted 14 hours of required training per individual. Team leaders received 90 hours of classroom training on issues that included responsibilities, accountabilities, and authority. The members of each team were committed to a common purpose, performance goals, and approach for which they held themselves mutually accountable.

D.7. Case Study 7 - Risk Management I



Producibility Element Highlighted:

1.3 Implement a Risk Management Program

Raytheon Missile Systems Company (RMSC), in Tucson, Arizona, established the Risk Management process as a proactive method to predict potential problems and risks, and effectively mitigate the risks by controlling the process, developing strategies, and addressing issues early in a program. This process enables RMSC to develop and deliver systems that meet customer requirements on schedule and within budget. Risk management is now a part of the monthly metrics required for all programs per RMSC's Integrated Process Architecture. In the past, RMSC used a reactive method, which often led to crisis management and insufficient time to implement the optimum solution.

Risk management begins with a basic process which is tailored to a specific program. The process relies on customer needs, lessons learned, expert opinions, and existing management guidelines to develop a specific risk management plan that retains the essential principles of the standard process. Risks are then identified, analyzed, and prioritized using various tools to address the differing aspects (e.g., cost and schedule simulations, process analysis, predictive identification). RMSC's main tool is Risk Manager (based on Filemaker Pro with Risk Register and Risk Matrix components) for planning, ranking, and controlling risk. This tool is used to encompass all the risks and criteria found with other commercial and government off-the-shelf risk tools. Prioritization is achieved by determining the probability and consequence of occurrence in order to calculate a risk factor for every identified risk.

Once RMSC prioritizes the program risks, risk reduction begins. The company develops mitigation plans to reduce the risk areas, which are tracked and reported weekly in IPTs and other program events. Risk Manager can output a series of differing reports, including a one-page summary graphic that shows probability of occurrence versus severity of occurrence, and plots the top ten risks as high, medium, and low. The Risk Management process continues throughout the life cycle of the program, with ongoing management of risks and identification of new risks being done at each stage of development.

At the start of the Evolved Sea Sparrow Missile (ESSM) program, RMSC had erroneously estimated that an additional \$45 million in funding would be necessary to complete the project. However, after implementing the Risk Management process and having the customer prioritize the requirements, RMSC was able to fulfill the ESSM program without additional funding. Since implementing the Risk Management process, RMSC significantly improved customer satisfaction as reflected in its 85% or higher (outstanding level) award fee rating across all programs. The Navy has also requested RMSC to use Risk Manager plots for all design reviews of the Standard Missile programs.

D.8. Case Study 8 - Risk Management II



Producibility Element Highlighted:

1.3 Implement a Risk Management Program

Lockheed Martin Tactical Aircraft Systems (LMTAS) has developed a risk management process to help program managers in such programs as the F-16 aircraft. This risk management process helps identify, quantify, evaluate, analyze, and manage in-house and contractor risks that, if unattended, could cause major program delays and higher costs.

LMTAS orients risk assessment around the product work breakdown structure (WBS). Risk consists of two components – the probability of failing to achieve a particular outcome and the consequence of failing to achieve that outcome. Each component is assigned a five-tiered risk rating (low, minor, moderate, significant, and high), and a Risk Scoring Matrix is developed (Figure D.2) from the two risk components and the rating criteria. Risk assessment templates are prepared for each element of the WBS by identifying the risk drivers such as design maturity, producibility, process metrics, plans, resources, manpower, and funding. Each risk driver for each

D.10. Case Study 10 - Program Launch Process



Producibility Elements Highlighted:

- Primary:** 1.4 Incorporate Producibility into New Product Introduction Strategy
- Secondary:** 1.1 Recognize the Need for Management Commitment
1.3 Implement a Risk Management Program

In the first quarter of 1997, ITT Industries Aerospace/Communications Division (ITT A/CD) in Fort Wayne, Indiana, was faced with starting 15 new programs. Previously when a contract was awarded, the departments would scramble to get resources; define budgets and schedules; and haphazardly start production. Departments tended to work independently with little coordination among themselves. With limited advanced planning and no formalized process, the introduction of new programs often lacked well-executable steps, dedicated resources, adequate funding, program objectives, and launch schedules. As a result, new program launches were unsuccessful, resulting in false starts, low yield rates, high defect rates, missed schedules, excessive costs, and interruptions in new and existing production. In 1997, ITT A/CD established the Program Launch process as an organized method to ensure that budgets, schedules, resources, equipment, facilities, and materials required for launching new programs are identified, planned, and implemented prior to production.

Upon contract award, the Program Launch process begins. The steps include assembling a core team of senior staff; interpreting the contract and plan; identifying key task leaders and training requirements; reviewing the technical baseline; updating the Integrated Management Plan (IMP) process; collaborating with senior staff and directors; establishing baseline/detailed schedules and budgets; identifying additional needs; and implementing the program. A program start-up checklist itemizes each action item, responsible member, plan date, and status. Approximately 80 people have received more than 20 hours of IPD training consisting of an overview, program launch procedures, effective meetings, a Microsoft Project video, electronic data management system accessibility, and other development tools as required (e.g., quality function deployment; requirements traceability and management; failure modes and effects analysis; decision making; risk management).

Elements key to a successful program launch include:

- Talking to the customer product line team and senior staff to clearly understand the goals of the program;
- Thinking about and interpreting these objectives;
- Collaborating with key task leaders and experts;
- Planning how to implement the program;
- Documenting the program clearly by using the IMP process to avoid misunderstandings due to trickle-down information and hand-offs;
- Concurring with key task leaders and senior staff;
- Launching the program by using the IMP process as the core team's implementation plan and contract with senior staff.

ITT A/CD's Program Launch process provides a smoother method to launch new programs. Currently, the company's baseline launch period for a new program is 65 days with a goal set for 60 days. Success relies on assembling a staff early, providing forecast training, establishing plans before starting work, and updating requirement documents.

D.11. Case Study 11 - Knowledge/Rule-Based Guidelines



Producibility Element Highlighted:

- 1.5 Employ Producibility Design Guidelines

Litton Amecom is creating a powerful knowledge base consisting of various design rules useful in the transition between design and manufacturing. In effect, the concept focuses on cumulative rather than

individual knowledge of product development. Under rule-based design, the design team evolves a design while using a rule base that constrains options that could be detrimental, thus forcing intelligent tradeoffs. In addition, by adding a knowledge base, the concept leads development teams to optimum conclusions, where a rule base alone only prevents detrimental choices.

The knowledge and rules compiled within the database come from various sources. One of the main sources consists of material derived from various problem investigation reports. Other sources include manufacturing constraints, military standards, and reliability physics journals.

Many organizations rely on experienced individuals or publications as sources for design rules, which creates the potential for losing or overlooking valuable information over a period of time. The knowledge/rule-base concept addresses this problem by providing an optimum repository for storing and compiling rules. It is easily accessible, maintainable, and transportable. In effect, it keeps the knowledge "off the dusty shelves."

The nature of the data storage is more than just a database. The software is actually an artificial intelligence (AI) architecture with the capability of helping the user achieve several levels of information cross-reference. The use of AI is a natural evolution because of its potential for on-line use with Computer Aided Design, Computer Aided Engineering, and Computer Aided Manufacturing. In fact, AI was found to be helpful for the more complicated rules which require implementing algorithms.

The database is intended to benefit users with backgrounds in all phases of design and manufacturing, including electrical, mechanical, reliability, test, components, and manufacturing engineering. Ultimately, issues to be addressed in the database will include not only reliability and producibility guidelines, but also performance and economic tradeoffs. In general, the knowledge/rule base developed by Litton Amecom promises to be a very powerful tool which will smooth the transition between design and manufacturing.

D.12. Case Study 12 - Mechanical Design Guidelines

Producibility Element Highlighted:

1.5 Employ Producibility Design Guidelines



Computing Devices International (General Dynamics Information Systems) is in the process of developing mechanical design guidelines. The guidelines resulted from a TQMP (Total Quality Management Process) recommendation for reducing the number of mechanical design errors (engineering change orders) and to produce more consistent design quality. The document enables mechanical engineers to do-it-right-the-first-time. It is a formal framework for a disciplined design process as well as a training curriculum for new engineers and a method to enhance design reviews and to document corporate knowledge. A sample of key sections are: Design Process; Aerospace Specifications and Standards; Component/Material Selection; Human Factors; Mechanical Tolerancing; Product Assurance; Reliability and Maintainability; PCB Design and Documentation; Thermal; Structural; Manual and Automated Assembly; Electromagnetic Interference/Radio Frequency Interference; Mechanical Computer-Aided Design; Test; and Finishes.

New sections can be added to cover other necessary topics. Sections are authored by field experts and reviewed by peers, managers, and consultants. Revisions are made the third quarter of each year following a training session for new mechanical engineers.

D.13. Case Study 13 - Benchmarking Process

Producibility Element Highlighted:

1.6 Instill a Commercial Best Practices Philosophy



The McDonnell Douglas Aircraft (MDA)(St. Louis) (Boeing Aircraft and Missiles) benchmarking program builds on techniques used by companies such as Xerox, IBM, AT&T, Texas Instruments, and Motorola. It is a systematic and continuous measurement process for collecting benchmarks on superior processes, products, and services from other organizations. The process determines the specific actions for enhanced performance and integrates the results into the MDA (St. Louis) Continuous Process Improvement Process.

A five-step approach is applied in this MDA effort. Before a study is conducted, process capabilities, expectations, goals, and metrics are established and obvious problems are addressed. The company is highly

selective in its benchmarking program. For example, in determining what to benchmark, MDA (St. Louis) focuses on critical or high priority processes, products, or services that impact customer satisfaction and provide a competitive advantage.

The process is disciplined and uncomplicated. Easy-to-use templates provide guidance for selecting and prioritizing benchmarking topics, performing benchmarking readiness assessments, and other key activities. Hierarchy models of the types of benchmarking and data collection methods are applied, and personnel are trained in the advantages and disadvantages of each method. Benchmarking champions at the company and corporate levels provide consistency and leadership in continuing to develop and improve the benchmarking process.

Training development for benchmarking includes looking at the best training programs in industry. Three classes are available at MDA (St. Louis): a one-day course, a two-hour overview, and the Voluntary Improvement Program. The classes are available to all MDA (St. Louis) employees and are also offered to suppliers and external customers at no charge. All senior management at the vice-president and director levels have received the two-hour overview. Government representatives have also been trained, and the courses are in demand by suppliers.

The benchmarking process is very effective in obtaining participation from benchmarking partners. One indication of this is a response rate of consistently greater than 50% for benchmarking questionnaires sent to other companies, more than double the national average response rate. Future improvements to the process include development of an internal database of best practices, corporate-wide process integration, and continuous improvement.

D.14. Case Study 14 - Benchmarking as a Tool for Quality Assessment



Producibility Element Highlighted:

1.6 Instill a Commercial Best Practices Philosophy

Initiated in 1990, the benchmarking program of Raytheon TI Systems (Dallas, TX) is an outgrowth of the TI commitment to quality awareness and continuous improvement. Benchmarking, the process of continually searching for the best methods, practices, and processes, involves adopting or adapting good features and implementing them to become the "best of the best." Active commitment from TI DSEG management and benchmarking teams have been critical aspects of the program's success.

The benchmarking fundamentals of knowing company strengths and weaknesses, maintaining an awareness of industry leaders and the competition, incorporating the best, and gaining superiority are incorporated into four basic steps.

- A planning phase - where the team develops a functional flowchart of their current process and critical performance measures are derived;
- An analysis phase - where the team focuses on practice and process differences by analyzing outputs and results;
- An integration phase - where findings are presented, performance gaps are understood, and impact of change is analyzed;
- An action phase - where action plans, schedules, and measurements are defined and implemented.

As a part of the benchmarking program, a benchmarking handbook has been produced that explains the benchmarking process; describes the four types of benchmarking (internal, competitive, functional, and generic); provides information sources for identifying industry leaders; and presents factors for successful benchmarking. A quarterly benchmarking newsletter is also published. Benchmarking studies are ongoing in many aspects of operations including concurrent engineering; PWB design; supplier management processes; self-directed work teams; software quality; customer satisfaction measurement; quality training; health care compensation; material handling and bar code systems; strategic planning; flow solder processes; cellular manufacturing for PWB assemblies; ergonomic and safety programs; and purchase order systems.

The Raytheon TI Systems benchmarking team members have been involved with a number of external groups and have provided benchmarking training to other companies such as Amoco Oil, IBM, Phillips Petroleum, Boeing, and AT&T.

D.15. Case Study 15 - Best Practices Program



Producibility Element Highlighted:

1.6 Instill a Commercial Best Practices Philosophy

Lockheed Martin Electronics & Missiles has instituted a company-wide Best Practices program that focuses on the quality of the process as well as the product. The approach provides broad coverage of representative Department of Defense and other customer thrusts such as the Army's Contractor Performance Certification Program (CP)², the Air Force's Manufacturing Development Initiative, ISO 9000, and Agile Manufacturing, and incorporates them into 12 Best Practices. Each of the Best Practices is clearly defined and supported by a vice-president-level, executive advocate and a management implementation team.

Lockheed Martin's Best Practices program was a response to major forces such as changes in the defense market, downsizing, and decreased funding levels for defense-related programs. The multi-faceted objective of the program is to increase market share and profitability by continually benchmarking customer, industry, and Electronics and Missiles improvement initiatives; integrating them into a coherent set of focused practices and metrics; coordinating the implementation plan for these practices; publishing and marketing the Best Practices; and continuously measuring, assessing and re-evaluating.

Under the leadership of the executive advocate for each Best Practice area, the implementation team identifies initiatives and develops plans and milestones for implementation. The plans cover 18 months, include key elements, identify responsible individuals, and specify metrics. Each of the Best Practice areas designates a continuing series of "Silver Bullets," each an initiative targeted for that practice for completion in the current year across all active programs.

The Best Practices Program at Lockheed Martin is a highly effective, company-wide process that enables the company to operate proactively within the environment of rapid and constant change in the defense marketplace. The program increases credibility of proposals, is effective in opening new markets, proliferates the processes and tools, and is updated annually to meet quality, cost, schedule, and performance commitments.

D.16. Case Study 16 - Supplier Best Practices



Producibility Element Highlighted:

1.6 Instill a Commercial Best Practices Philosophy

McDonnell Douglas Aircraft (MDA) (St. Louis) (Boeing Aircraft and Missiles) recognizes that many of its suppliers have attained levels of proficiency in processes and techniques which are efficient and effective, some which may have application at MDA or be used to improve the overall supplier base. Teams perform Business Process Assessments as part of MDA's Preferred Supplier Certification process and observe many of these processes and collect the information. No proprietary or confidential company information is collected, only that information which can be used to improve MDA (St. Louis) and which its suppliers are willing to provide and share. These practices and processes are observed and validated first-hand by an assessment team.

Before data is collected, the guidelines are discussed with the supplier to determine any objections to documentation of the process for benchmarking and/or identifying the firm to other MDA (St. Louis) suppliers as a possible contact for benchmarking. Participation is strictly voluntary and no pressure is applied to the supplier. Processes receiving a high score by the MDA (St. Louis) assessment teams are considered as opportunities for formal benchmarking. Unique processes may be considered if they have application external to the firm being reviewed. Processes scoring slightly lower but viewed as outstanding may also be considered for benchmarking. These often include recent processes which appear to have very good results but are not yet proven.

Approximately 16 supplier best practices were documented, and interest and participation were growing. The program offers a unique and effective way to improve the capabilities of MDA (St. Louis) and also offer improvement opportunities to its supplier base.

D.17. Case Study 17 - Process Capability Analysis

Producibility Elements Highlighted:

Primary: 2.1 Understand Current Process Capabilities (Company and Supplier)

Secondary: 3.3 Perform Trade Studies on Alternative Product and Process Designs

4.2 Error-Proof the Design

Understanding manufacturing capabilities during the earliest design phases can significantly reduce program costs, cycle times, and defect rates. At Raytheon TI Systems in Dallas, Texas, emphasis has been placed on early identification of defect drivers through analyses such as Process Capability Analysis (PCA) and Process Failure Mode and Effects Analysis (PFMEA).

PCA is based on a series of process capability models that accurately predict manufacturing labor costs, cycle times, and defect rates for the processes required to assemble or fabricate the components of a design. PFMEA uses the traditional FMEA techniques, but incorporates manufacturing, assembly line workers, process engineers, as well as design engineers, into a formal review of the assembly or fabrication process. PCA supports the Process FMEA analysis by identifying the critical defect drivers in the process and providing recommendations for eliminating their resultant defects.

Program X, a major program at Raytheon TI Systems, has been using PCA as an interactive design tool to minimize defects during design. PCA has proven successful in providing valuable inputs to design engineers while their designs are still in progress. This enables trade studies to be evaluated to yield the optimal design, balancing performance requirements with manufacturing process capabilities.

Program X had been working a Pre-Engineering Manufacture/Design concept primarily to develop a product that met its performance requirements at the lowest possible cost. Using PCA, the program was able to closely look at defect drivers and identify how to eliminate defects before going into production. Through Program X's PCA, the elimination of defects was directly linked to reducing program costs and cycle times.

As the design team conceptualized various subassembly designs, PCA was used to evaluate the design for Six Sigma / variability reduction purposes. Sixteen of the system's 20 subassemblies were identified as critical feature sets and were targeted for analysis. By applying PCA models, the design team got immediate feedback on the effects their design decisions would have in manufacturing. In some cases, the design decision was made real-time to adopt the approach recommended by the PCA model. Following the complete analysis, PCA recommendations were documented and submitted as part of the design technical package. Included in this report were the PCA results based on the current design, recommendations for changes, and projected results with those changes incorporated. For the 16 assemblies analyzed, incorporating PCA recommendations resulted in an overall defect-per-million-opportunity reduction of 3,400. Extended across the program life-cycle and production quantities, the resulting cost avoidance was over \$42M.

Recommendations based on the PCA models included items such as moving rubber stamp symbolization of part numbers from the assembly level to incorporate a better methodology at the fabrication level. Other recommendations were increasing screw sizes and incorporating orientation configurations to prevent mirrors, lenses, and components from being incorrectly installed. Additionally, changes in the wire sizes for interconnect cables and the methods of inserting the wires into the connectors generated significant improvements.

Program X performed a PFMEA on the designs to further identify the processes used in the assembly of the hardware, the potential process failure modes, and the potential effects of those failure modes. This analysis took the PCA analysis a step further to ensure the processes used to assemble the hardware would be well understood before the hardware was built. Results from the PFMEA and PCA analyses were iterated until the team eliminated defects and manufacturing risks from the product or identified contingency plans for those issues or defects which could not be eliminated.

As proven by the significant cost avoidance realized by Program X, development programs have greatly benefitted from PCA and PFMEA. PCA and PFMEA provide valuable information to support critical tradeoffs required to ensure product performance and meet process objectives while addressing customer needs. To fully understand the cost impact that design decisions make on defect rates, it is imperative to consider manufacturing process capabilities during the earliest possible design phase.

D.18. Case Study 18 - Process Capability Models

Producibility Elements Highlighted:

Primary: 2.1 Understand Current Process Capabilities (Company and Supplier)

Secondary: 3.3 Perform Trade Studies on Alternative Product and Process Designs

Raytheon TI Systems (Dallas, TX) uses Process Capability Analysis (PCA) to focus on key manufacturing process capability constraints in the early design phases. By understanding and designing within process capability constraints during the conceptual and detailed design phases, designs have a significantly greater probability of meeting cost, cycle time, and quality goals. Because balancing cost, cycle time, and quality considerations within the PCA prove to be difficult and time-consuming, Raytheon Systems Company has developed the PCA based on a series of Process Capability Models (PCMs) to quickly predict the impact to cost, cycle time, and quality.

Input derived from the design features and characteristics mapped to the company's manufacturing process capabilities are used to determine which processes will be required to produce the given design. Comparing the known manufacturing process capability constraints with the current state of the design, the PCMs provide the user immediate feedback on predicted cost, cycle time, and Six Sigma ratings for the design.

The PCMs are based on historical data and expert knowledge. They are performed on individual fabrications at the part level to top system assembly level. The PCA is currently based on over 255 PCMs that are validated and maintained with current manufacturing process capabilities. This information is critical input to design tradeoff analysis efforts, which are optimally conducted as early in the design process as possible to maximize benefits.

D.19. Case Study 19 - Understanding Composites and Their Processing Requirements Prior to Production

Producibility Elements Highlighted:

Primary: 2.1 Understand Current Process Capabilities (Company and Supplier)

Secondary: 1.3 Implement a Risk Management Program

The Lockheed Martin Tactical Aircraft Systems (LMTAS) composite part design team for the F-22 aircraft planned to use new part materials, configurations, and tooling materials. However, LMTAS had no experience or historical database to determine if the capability existed to successfully fabricate these concepts within program cost and schedule constraints. This situation highlighted the need for development of composite manufacturing processes before entering the F-22 Engineering and Manufacturing Development phase of the program.

The team determined that a producibility test program was required to address these issues. For the test program to succeed, it had to provide proven materials for parts and tools; a proven engineering and tool design philosophy; part designs that would be producible with the baseline materials, processes, and tooling families; and proven manufacturing capabilities established for benchmarking. Consequently, a multi-disciplined Risk Reduction Team was created and the following test guidelines established:

- Design components were to meet actual airframe requirements.
- Production readiness and producibility on key part family candidates were to be demonstrated on key part family candidates. Key parts were to be established as program "pilot" proof articles.
- Baseline manufacturing processes, composite materials, tooling family, and quality methods were to be demonstrated and validated.
- The team's efforts were to be coordinated with the engineering Structural Development Test plan and Effects of Defects plan.
- Issues of engineering, manufacturing, and quality risk were to be resolved to support the Engineering and Manufacturing Development schedule.

-
- Accept/reject criteria for Quality Assurance/Inspection were to be determined.
 - Drawing specifications, check procedures, and incremental release procedures for engineering and manufacturing data to support concurrent design concepts were to be established.
 - Process Specifications, Material Specifications, Variability Reduction Procedures, and Quality Assurance processes were to be proof-loaded.
 - Standardized Work Instructions and visual aids by part family were to be established.
 - Risk reduction tools were to be fabricated using contracted F-22 tooling vendors.
 - Components were to be fabricated and inspected with production equipment and procedures.
 - Lessons learned were to be documented.
 - Production capacity and facilities were to be verified.

The Risk Reduction Team reviewed the preliminary structural layouts and decided that composite parts could be segregated into five primary families of components: highly contoured inlet duct skins; fuel floors/shear webs; medium contoured outer mold line skins; thermoplastic weapons bay doors skins (outer mold line); and thermoset weapons bay inner mold line door skin (honeycomb panel inner skin).

From these families, three representative composite parts were selected and fabricated: an inlet duct skin, a fuel floor, and an outer mold line skin. These articles were judged to be among the most difficult of their part families. The Risk Reduction Program used the production drawings, planning, material requirements planning, tooling, and inspection systems planned for the F-22.

Statistical process control data was collected and used as a baseline for the division process capabilities for these types of parts. These capabilities were used to establish the tolerance guidelines in the production drawings. This activity resulted in a yield rate of 98% on composite part production during the Engineering and Manufacturing Development phase of the F-22 program. This yield rate, one of the highest in the aerospace industry, is usually not achieved until much later in a program.

D.20. Case Study 20 - Machine Capabilities and Tolerances

Producibility Element Highlighted:

2.1 Understand Current Process Capabilities (Company and Supplier)

Lockheed Martin Tactical Aircraft Systems (LMTAS) in Ft. Worth, Texas determined that previous producibility information was normally process-based. For example, although a certain machine could hold a certain tolerance, the conditions or attributes of the design would affect what tolerance the machine could hold. Consequently, LMTAS found it needed to thoroughly categorize those factors affecting machine capabilities.

Using an Intranet program, LMTAS users can now choose from Process Characteristic, Tool Type, Material, Material Form, and Part Family categories. The user can know all or some of these attributes, and the system will interactively limit the choices. The user then submits the inputs, and the program reads the database and supplies the exact capability information based on the attributes chosen. This data provides statistical process control history; recommended tolerance; rules associated with the key characteristic; notes associated with the process; links to company, industry, or government standards or specifications; and tables or other illustrations.

D.21. Case Study 21 - Partnering with Suppliers

Producibility Elements Highlighted:

Primary: 2.1 Understand Current Process Capabilities (Company and Supplier)

Secondary: 1.2 Organize for Producibility

Lockheed Martin Electronics & Missiles (E&M) considers supplier partnerships and related practices critical to winning new business. Within this arena, there are a number of active initiatives and thrusts including:

strategic alliances, teaming with suppliers, supplier membership on Integrated Product Teams (IPTs), Design for Manufacture/Assembly (DFMA) flowdown to suppliers, Statistical Process Control/Variability Reduction flowdown, expanding the blanket purchase and group purchase base, supplier base reductions, supplier metrics, and best value awards.

Partnerships foster joint commitments between companies and promote shared investments that focus internal research and development activities and result in ownership of products. Partners take mutual ownership of problems and solutions and apply their complementary strengths to address weaknesses.

Lockheed Martin is rapidly moving from the traditional adversarial approach to subcontracting. This new approach to supplier partnerships is based on sharing, defining clear expectations, mutual trust and respect, commitment, responsibility, and performance. Partnerships are initiated by selecting the best technology or product available and entering a teaming agreement with the provider. Communication is open and full, and sensitive data is shared. To encourage such communication, E&M employs confidentiality agreements that are skewed in favor of protecting the discloser's technology versus limiting the receiver's liability. The company is committed to partnering and has mandated this approach for all future starts. The philosophy is also being applied to mature programs where possible.

Partnerships and alliances are a key part of the procurement process and are integrated early. Subcontractors are involved in the market analysis, pre-proposal, and proposal phases. They participate in life-of-the-program decisions, requirements specifications, design for manufacture and assembly, manufacturing development initiatives, and concurrent engineering. Benefits of this involvement include long-term contracts, design-to-unit cost pricing, mutual commitments to program goals, and use of commercial standards.

All supplier initiatives at Lockheed Martin Electronics & Missiles form an integrated process that results in best value and mission success. Unique involvement activities include Partners in Excellence Conferences, General Managers Meetings, and supplier membership on IPTs. Supplier membership on IPTs has been implemented successfully on two major programs and is mandated for all new programs. Benefits of IPT involvement include: transferring build-to-print design responsibility to subcontractors with resultant savings; co-development of proposals, designs, test equipment, manufacturing tooling and processes; sharing the cost of key process development; and other cost reduction activities such as design for manufacture and assembly which reduced the cost of an existing assembly by over 70% on one program.

D.22. Case Study 22 - Manufacturing Technology Insertion



Producibility Elements Highlighted:

- Primary:** 2.2 Predict Future Process Capabilities
- Secondary:** 1.2 Organize for Producibility
- 1.3 Implement a Risk Management Program
- 1.4 Incorporate Producibility into New Product Introduction Strategy
- 2.1 Understand Current Process Capabilities (Company and Supplier)

The Hamilton Standard Electronic Manufacturing Center instituted several process changes for Manufacturing Technology Insertion to address advanced packaging, environmental, and cost competitive technologies needs for future electronics business.

Several factors necessitated improvement to the previous process. Technology selection was primarily an engineering process, and, due to conflicting goals, manufacturing department buy-in did not always occur. There was also no manufacturing group dedicated to new technology process development. Often, delays resulted from unplanned and difficult to approve manufacturing resources and capital, and, consequently, manufacturing capability was seldom available in time to initiate new product development. Production implementation was often unsuccessful due to insufficient understanding of the risks and inadequate allocation of resources.

Hamilton Standard's Manufacturing Technology Insertion process improvements included formation of a dedicated manufacturing technology group and a documented manufacturing technology insertion process,

facilitated by use of detailed flowcharts for benchmarking and continuous improvement. New process steps included:

- Requiring that estimated development costs, estimated capital costs, project schedules, and risk levels be provided for manufacturing development projects.
- Demonstrating process feasibility and identifying equipment requirements, equipment costs, and risk levels.
- Providing for timely acquisition for equipment and early identification of committed suppliers.
- Developing manufacturing procedures to provide a robust process ($C_{pk} > 1.3$) and design guidelines. This step transitions the process to production with full documentation details and process owner transfer.

Process improvement teams, engineers, and manufacturing associates establish each business unit's technology insertion schedule. The schedule is then used as a tool for resource, capital, and facility planning to improve time to market of products. An improved planning and development process facilitates risk management and allows manufacturing capability to be in place in time for new product development. Cross-functional involvement in the entire process results in buy-in and commitment throughout the organization.

D.23. Case Study 23 - Obsolescence and Commercial Technology Insertion



Producibility Element Highlighted:

2.2 Predict Future Process Capabilities

Lockheed Martin Electronics & Missiles successfully applies requirements management through closely-related initiatives. Obsolescence Management combines manufacturer information and technology assessments with various tools to predict when components and products will become obsolete. Commercial Technology Insertion addresses replacing military-specified parts with commercial products, obsolete units as well as new designs.

Obsolescence Management provides risk information on electronic component technologies to help designers determine whether the components they select will meet the life cycle development and cost-of-ownership requirements of the design. Obsolescence Management uses the Document Information and Control System for displaying on-line data. This on-line obsolescence information helps the engineer select current technology for product designs and also provides source data used by procurement and product assurance personnel. The system also furnishes descriptive data for standardization, parts control, and part status.

In the second initiative, Lockheed Martin is focusing Commercial Technology Insertion's initial effort on microcircuits. A commercial component is any non-military part, ceramic or plastic, including telecommunication, computer, medical, automotive, industrial grade, or other devices. The Commercial Technology Insertion program provides a comprehensive plan for the selection, application, and procurement of reliable, low-cost commercial components. Current emphasis is on replacing ceramic components with plastic. Moisture-induced and temperature cycling failures are two major long-term reliability considerations for plastic components. These considerations are being analyzed against various product requirements. Potential cost saving opportunities and return on investments for plastic over ceramic components can exceed a 75 to 1 ratio.

D.24. Case Study 24 - Affordability as a Key Product Goal



Producibility Elements Highlighted:

Primary: 3.1 Identify Product Goals

Secondary: 3.3 Perform Trade Studies on Alternative Product and Process Designs

Northrop Grumman established a proactive cost reduction plan for the F/A-18 E/F aircraft program which has become a model for other affordability initiatives within the company. The company also defined a standard

procedure for affordability/producibility management of the F/A-18 program. Key elements of this procedure include:

- Establishing baseline and target costs for each component of the aircraft;
- Constructing a database that contains all cost estimate, projection, and affordability data;
- Assigning responsibility for initial and follow-through proposals for each work package down to the team leader level;
- Conducting trade studies to identify alternatives and impacts for cost reduction measures;
- Coordinating and integrating affordability and producibility initiatives;
- Creating affordability status reports; and
- Quantifying, tracking, and validating all savings.

Northrop Grumman's standard process procedure has several different affordability goals or allocations, such as average unit production cost (flyaway cost); initial support investment cost; and operating and support costs. These affordability goals are allocated by the work breakdown structure and flowed down to the team leader level.

The company has tracked and maintained cost baseline and affordability initiatives since 1992. Through cost reduction measures, Northrop Grumman has been able to keep aircraft flyaway and life-cycle costs within contractual requirements despite configuration changes and increased material cost. Cost reduction measures have also been responsible for a 10% savings in flyaway costs which helped offset a 12% increase in flyaway costs due to configuration and other changes.

D.25. Case Study 25 - Design-to-Cost I



Producibility Elements Highlighted:

Primary: 3.1 Identify Product Goals

Secondary: 3.3 Perform Trade Studies on Alternative Product and Process Designs

Computing Devices International (General Dynamics Information Systems) has introduced a design-to-cost (DTC) approach to new product development. This process was developed in early 1992 to provide product designs that are within cost guidelines. Computing Devices International can now determine whether cost goals are achievable early in the design cycle to allow for any necessary corrections.

Prior to implementing this new approach, product cost often would not be known until after the design was complete, usually resulting in either redesign or cost overrun, and producibility factors were often overlooked until too late. The customer requirement to avoid cost overrun prompted an improvement to the process. Analysis of previous product costs indicated that approximately 80% of the total cost was in individual part costs. Therefore, realistic product cost goals, coupled with accurate part costs, could be used to design products that were within budget.

A team of marketing, program management, and integrated product development team personnel now determines DTC production goals by year and quantity using preliminary parts and labor costs. During the preliminary design phase, a procurement team then obtains accurate part costs from suppliers, and a producibility team concurrently reviews the design for testability, producibility, and labor costs. Cost drivers are identified, trade studies performed, and make/buy decisions made. A favorable DTC review leads to the detailed design phase. In that phase, a DTC model is constructed using accurate part and labor costs. An iterative analysis is conducted in which trade studies are performed, the design is revised for producibility and testability, and the DTC model is updated as a function of DTC goals. The DTC database is hosted on a network for multiple access by the DTC team members, thereby providing electronic collocation.

By determining early in the design cycle whether cost goals are realistic and attainable, Computing Devices International can provide credible information for planning and resource allocation and assure customers that their requirements can be met without redesign or cost overrun.

D.26. Case Study 26 - Design-to-Cost II



Producibility Element Highlighted:

3.1 Identify Product Goals

The design-to-cost (DTC) initiative at Hamilton Standard Electronic Manufacturing Center (HSEMC) is a major element of the overall product design and development life-cycle management process initiated in the proposal stage. This DTC process results in the establishment of product target cost goals that meet customer expectations and is broken down into sub-system, sub-assembly, and piece part labor and material goals.

DTC is an iterative process that steps through a cadre of legacy data, design criteria, producibility guidelines, reliability information, and other elements to establish targets. The process encompasses the setting of individual cost targets; defining a process that will achieve the targets; implementing and modifying the defined process; analyzing data collected; and modifying the analyses.

The implementation of this well-defined process and assigned responsibilities collectively has resulted in customer satisfaction and cost-effective designs. The DTC cost-over-target average for 19 major programs at HSEMC is only 0.04%.

D.27. Case Study 27 - Application of Quality Function Deployment to Battery Design



Producibility Elements Highlighted:

- Primary:** 3.1 Identify Product Goals
3.2 Identify Key Characteristics

Sandia National Laboratories uses the Quality Function Deployment (QFD) process as the organizational aid in integrating the ability to determine product requirements from customers' needs and expectations, and ensure that these requirements are realized in a product or service. Integrating these customers' requirements into a commercial product is best accomplished through a step-by-step process, a primary reason for Sandia choosing QFD, a structured product planning and development tool, first used in Japan, to guarantee customer requirements are realized throughout the product life-cycle.

The QFD process is a structured activity that begins with a conceptual design and ends with a technical data package. In Phase I, a multi-disciplinary team translates key customer requirements into product measures that, if satisfied, will ensure customer satisfaction. Phase II translates the key product measures into parts characteristics. In Phase III, key parts characteristics are translated into manufacturing process characteristics. Finally, in Phase IV, these manufacturing process characteristics are translated into manufacturing process controls. This structured deployment of key requirements guarantees that the product development team maintains its focus on these requirements and realizes customer's needs and expectations repeatedly in the manufacture of the product.

Application of this process is demonstrated with Sandia's battery design. Since 1980, Sandia has used lithium/sulfur dioxide "D" cell batteries to provide highly reliable, continuous power (up to five years) in weapons applications. Because of the lab's responsibility to meet demanding DOE requirements, the Exploratory Battery Department demonstrated the feasibility of adapting an improved and innovative design to an established commercial lithium/thionyl-chloride battery technology that revolutionizes the way nuclear surety devices are powered in weapons. By using this new cell, in conjunction with new generation multichip module technology electronics, the size of the power supply can be reduced 50% and the service life doubled while maintaining ambitious safety and reliability requirements. To achieve this goal, the Product Realization Team utilized the QFD four stage process to guide the technology transfer effort and to communicate progress to the customers.

Applying QFD to the battery design produced the following results: (1) a longer battery service life which increased the limited-life components exchange interval, resulting in time and cost savings in nuclear weapons stockpile maintenance and (2) comparable lithium/thionyl-chloride cell manufacturing costs to those for the lithium/sulfur dioxide cell, at the same manufacturing quality.

The technology to produce this product for Sandia National Laboratories applications was successfully transferred to a commercial manufacturer, Eagle Picher Industries, Inc., Joplin, MO, enabling it to produce a variation of this cell for commercial application. Additionally, the Exploratory Battery Department was awarded Sandia National Laboratories 1994 President's Silver Quality Award for this effort.

D.28. Case Study 28 - Key Characteristics and Variability Reduction



Producibility Element Highlighted:

3.2 Identify Key Characteristics

Lockheed Martin Electronics & Missiles has adopted an approach called Key Characteristics and Variability Reduction in its quoting, design, and manufacturing processes as part of the company's continuous improvement efforts. This approach has enabled Lockheed Martin to translate critical customer requirements into detailed specifications, facilitating the separating of "critical few" from "trivial many" product features.

In the past, Lockheed Martin Electronics & Missiles followed the classical approach of defining the system requirements, conducting a tradeoff analysis, assigning component requirements, and detailing the resultant specifications. However, this did not support the desired practice of focusing efforts on the few critical attributes, while allowing standard practice to accommodate the non-essentials of the design.

Acknowledging that it would be extremely difficult to conduct variability reduction techniques on all the variables of all the products/processes involved, Lockheed Martin Electronics & Missiles identifies the relatively few high-level critical features of any design. Each of these features, in turn, could have many crucial components contribute to the overall criticality, but the analysis greatly reduces the field of consideration.

Once the critical features are identified, variability reduction and the resulting statistical tracking are applied. Process capability studies and a tradeoff analysis are conducted to determine which machines/processes can achieve the required key characteristics.

One result of using this methodology was the invention of a variability reduction flag being incorporated into Lockheed Martin Electronics & Missiles' drawing packages and procurement documentation. This flag indicates to both subcontractors and their own shop floors which geometric features are absolute "must-haves" and which features they can apply the knowledge of their trade to modify for ease of manufacture. This effort provides a substantial benefit to the design process by allowing the original equipment manufacturer to provide input up front. It also greatly reduces the number of Engineering Change Proposals that follow any new design.

D.29. Case Study 29 - F-22 Variability Reduction



Producibility Element Highlighted:

3.2 Identify Key Characteristics

Lockheed Martin Tactical Aircraft Systems (LMTAS) (Ft. Worth, TX) has established a Variability Reduction (VR) program to meet a contractual requirement of the F-22 program. Under the contract, the VR program and related activities are designated as award fee criteria. There are several defined objectives under the contract which includes: to reduce variation of key characteristics; estimate the impact of process variations on key characteristics; verify that key characteristics requirements are compatible with the manufacturing process; identify producibility studies for improving quality, increasing integrity and/or reducing production cost; characterize key manufacturing processes using statistical data; reduce scrap, rework and repair; and reduce reliance on end item inspection.

A seven-step approach has been developed to meet these objectives. This approach begins by identifying key characteristics. A key characteristic is a feature of a material, part, or assembly critical to the fit, performance, or integrity of the product. The VR team used Design of Experiments and Quality Function Deployment tools in a structured approach to systematically break down top-level requirements into lower level components. These lower level requirements are examined to decide key characteristics that are then associated with related individual control characteristics. The second step in the program is to correlate the identified key

characteristics to processes. This is followed by prioritizing and selecting firm key characteristics. Step 4 involves developing Variability Reduction Instructions for each of the selected key characteristics. These instructions include product definition, key characteristic description, manufacturing approach, data collection, tooling approach, process assessment, process analysis, and product feedback. Once developed, the Variability Reduction Instructions are incorporated into the Product Development and Definition build-to package. Step 6 involves actual process control of the key characteristics, and the final step provides feedback reporting for monitoring and continuous improvement activities.

The VR team on the F-22 has identified 2,561 product key characteristics. These are part-number driven and equate to the 678 processes/part families that led to the development of 126 Variability Reduction Instructions. Lessons learned during this process include the need to incorporate VR into normal engineering requirements to help early identification of key characteristics. This would ease earlier usage of Design of Experiment and Quality Function Deployment tools. Cross functional VR teams greatly simplified the implementation of VR, the use of quality tools was widely accepted by the IPT, and active coordination among the three primes ensured a common approach.

No award fee on the F-22 has been lost since the implementation of the VR program. An example of other benefits can be shown by looking at improvement in the NC trim operation of composite doors, skins, webs and floors. Since this system has been in place, the Cpk for this operation has improved to its current level of 1.2 or about 99.9%.

D.30. Case Study 30 - Design for Manufacture/Assembly in Concurrent Engineering



Producibility Elements Highlighted:

Primary: 3.3 Perform Trade Studies on Alternative Product and Process Designs

Secondary: 1.1 Recognize the Need for Management Commitment

Lockheed Martin has identified and effected an important methodology to successfully implement the principles of concurrent engineering. This Design for Manufacture/Assembly (DFMA) approach ensures the proper balance between design goals and ease of manufacture and assembly. The net result is a robust design that is more cost-effective to manufacture.

The company previously applied the concurrent engineering philosophy using a traditional design review process. It determined that a formal event called a DFMA workshop was needed to ensure that design-for-manufacture, design-for-assembly, and design-for-producibility considerations were addressed. After careful analysis, Lockheed Martin selected the Boothroyd Dewhurst, Inc. software to help achieve this objective. To demonstrate commitment, Lockheed Martin established a policy that DFMA be included in all programs.

Lockheed Martin embarked on a training program that taught the principles of DFMA and the specifics of the Boothroyd Dewhurst, Inc. tools to the product teams. The various disciplines represented on the team were taught the methodology, and the teams were required to use this approach in a real-world application. The teams first established the as-is baseline model of their products and then brainstormed and iterated solutions to simplify the assembly. Finally, at the end of the training, each team presented its analysis to management.

The ingredients critical to the success of this Lockheed Martin approach include mandating the requirement to utilize the DFMA approach, training personnel, providing each team a real-world case study, and involving management. The resulting synergy of this approach has helped the company achieve the desired goals of simplifying both the design and the processes necessary to manufacture and assemble the components of the design. Lockheed Martin has been able to significantly reduce the Bills of Material required to manufacture components, and, over the life-cycle of the many systems it produces, these component-level savings are significant.

D.31. Case Study 31 - Power Supply Trade Study

Producibility Element Highlighted:

3.3 Perform Trade Studies on Alternative Product and Process Designs

An electronic instrument manufacturer was considering using a new power supply being offered by a small vendor. The new power supply under consideration was much smaller and would take up less instrument frame space than the standard power supply that had been provided by a large company for several years. Additionally, the new power supply would weigh less than half as much as the standard power supply. The size reduction would improve producibility by allowing more access room for other components. The weight reduction would reduce ergonomic risk to the material handlers and assemblers in the production of the instruments, as well as to the field service engineers at the customer location.

However, with the new power supply, inventory costs were expected to grow due to an increase in the number of parts in storage and part numbers that must be monitored by purchasing. Technical risk to the design process would be introduced, because not only had the power supply not been used in a product before, but also the vendor had never produced one. This risk might have affected quality as well as the project schedule.

The estimated cost avoidance of reducing occupational injuries due to the manual material handling of the current power supply was \$55.58 per instrument. This figure was based on the injury incidence of 3.4 injuries per 200,000 hours of production with the average incident cost of \$52,000 including lost time and medical costs. The production time per instrument is 64 hours. Injury cost avoidance = $[(\$52,000 \text{ per injury} \times 3.4 \text{ injuries}) / (200,000 \text{ hours} \times 64 \text{ hours per instrument})]$.

The assembly cost reduction, due to improved producibility, was estimated to be \$11.88 per instrument, based on a reduction of 0.8 production hours at an hourly rate of \$14.85 per hour.

The risk of delay in the project schedule was eliminated when, within three months of the request, the vendor delivered a working prototype. The tradeoff analysis was still ongoing when the prototype arrived for evaluation.

The quality risk cost was estimated to be \$4.11 per part, based on a 10% increase in failure rate. The current power supply failure rate was two per 100 units with associated cost of \$187 per failure to replace and refurbish (1.1 x 2 failures/100 units x \$187 per failed unit). There was no inventory cost increase because the new power supply replaced the previous parts and the inventory costs canceled each other out.

In this tradeoff analysis, the total life-cycle cost savings estimated for the replacement of the old power supply with the new one was: Cost savings (\$64.35) = injury cost avoidance (\$55.58) + reduction in assembly cost (\$11.88) - quality risk cost (\$4.11). As the result of this trade study, the electronic instrument manufacturer decided to use the new power supply.

D.32. Case Study 32 - System Engineering Trade Study

Producibility Element Highlighted:

3.3 Perform Trade Studies on Alternative Product and Process Designs



McDonnell Douglas Aerospace (MDA) (St. Louis) (Boeing Aircraft and Missiles) re-engineered its trade study process to improve the product and response time to its internal and external customers. Based on a description of what should be included in a trade study, MDA (St. Louis) surveyed its high priority customers to determine further requirements for an exemplary study. Responses cited the need for such studies to be accurate, timely, objective, thorough, complete, have a consistent format, be documented, present a range of options, and provide a technical recommendation. In order to meet customer quality requirements, each Trade Study conducted within Product Definition is expected to be characterized by a consistent set of elements which include:

- Clear problem statement
- Identification of requirements that must be achieved
- Ground rules and assumptions

- Decision criteria
- Resource requirements statement (source/man hours required)
- Schedule to accomplish (proposed and actual)
- Potential solutions and screening matrix
- Comprehensive array of feasible alternatives
- Comparisons of alternatives using decision criteria
- Technical recommendation of Trade Study Leader
- Documentation of Decisions leading to recommendation.

The MDA (St. Louis) trade study process has been thoroughly modeled and brought under a control process that ensures that studies are timely and of a consistently high quality. Scheduling planning extends down to requiring that study documents be delivered to participants before meetings to allow sufficient time to review the progress of the study results. Personnel involved in the process know what problems they are to address, who it should be coordinated with, and when they are expected to conclude the study.

D.33. Case Study 33 - Variation Simulation Analysis



Producibility Element Highlighted:

3.3 Perform Trade Studies on Alternative Product and Process Designs

McDonnell Douglas Aerospace (MDA) (St. Louis) (Boeing Aircraft and Missiles) uses Variation Simulation Analysis (VSA) to accurately predict and minimize variation in its products. This capability allows evaluation of alternative aircraft design and process concepts to facilitate the selection of optimum designs based on function, assembly processes, and cost constraints.

The variation simulation process includes four basic steps, beginning with inputting part geometry using an appropriate translator such as IGES. Part assembly tolerances and process capabilities are then identified, and the assembly sequence is defined as a tree structure. Finally, critical measurements associated with key product characteristics are identified. A Monte Carlo simulation is then run in which feature dimensions are randomly varied based on the tolerance, process capability, and assembly sequence data. A number of reports can be generated to provide information on the number of parts expected to be out of tolerance, and to identify the level of contribution of different part features and assembly processes to those failed parts.

VSA provides a substantial benefit in verifying design quality using software instead of the more costly fabrication process. Other benefits include improved ease of assembly; more rational assignment of tolerances based on assembly process constraints; and an ability to consider cost tradeoffs associated with lowering tolerances, improving processes, or reworking parts. For example, MDA (St. Louis) staff conducted a transmission mounting analysis for a major aircraft design and determined that in-line and parallelism-of-holes tolerance, set at 0.001-inch, could be increased to 0.003-inch. Another application of VSA resulted in the assembly of the F/A-18 fuselage extensions without the use of shims.

D.34. Case Study 34 - Aircraft Panel Complexity Analysis

Producibility Element Highlighted:

3.5 Perform a Complexity Analysis

An aircraft panel at Boeing containing numerous gussets, brackets, joints, and rivets was highly labor-intensive to fabricate. While not complex in individual features, the sum of the features created an extremely high-cost item. The IPT determined that the function supplied by this assembly did not justify the current cost. Consequently, the assembly became an opportunity for improvement. Manufacturing research and development personnel conducted a study and determined that a casting could be made that represented the configuration of the sheetmetal assembly and satisfied other conditions such as load requirements. A prototype was made for verification, and the sheetmetal assembly was replaced with the casting. The result was a cheaper and lighter part.

D.35. Case Study 35 - Change in Design Tolerance due to Complexity Analysis Results

Producibility Elements Highlighted:

Primary: 3.5 Perform a Complexity Analysis

Secondary: 3.3 Perform Trade Studies on Alternative Product and Process Designs

At Raytheon TI Systems in Dallas, Texas, a program contained a number of detailed and complex housings that had to be fabricated in the metal shop. The design engineer had called out a specific type of tolerance on the housing, based on performance requirements, that forced the use of costly jig bore machinery.

Using Process Capability Analysis (PCA), the design engineer was shown an alternate tolerance and its required values to produce the desired results using a Computerized Numerical Control machine. This suggested change was analyzed to ensure performance was not compromised if incorporated in the design. Since it was proven to have no degradation in performance, the new tolerance scheme was incorporated. The resulting cost savings based on higher yields and lower defect rates for the new process was \$550 per unit. Extended across the life of the project, this generated a cost avoidance of over \$4M.

What was not captured in this analysis were the hidden costs associated with the capital equipment. To produce the design as originally toleranced, added jig bore machine capacity would have had to be obtained to meet the program's requirements. Whether obtained through capital purchases or subcontracting work outside, this cost was estimated to be significant.

This effort highlighted the value of performing PCA, not only to ensure that designs can be manufactured cost-effectively and defect-free, but also to eliminate hidden costs that may not become evident until much later in the program. Moreover, this one tolerance callout on one design, while representing only \$550 savings per unit, is an indication of other significant opportunities across all designs. The application of PCA across program life-cycles can accumulate the seemingly small per unit savings and hidden costs and quickly add up to millions of dollars in cost avoidance.

D.36. Case Study 36 - Complexity Analysis Examples

Producibility Element Highlighted:

3.5 Perform a Complexity Analysis

Ford Motor Co. saved \$11B and built better vehicles by simplifying and standardizing (Schwartz, 1996). Examples include:

- Offering three types of carpeting rather than nine saved an average of \$1.25 per vehicle, or \$8M to \$9M per year;
- Standardizing to five kinds of air filters rather than 18 saved \$0.45 per vehicle, or \$3M per year;
- Standardizing on one type of cigarette lighter instead of 14 varieties saved \$0.16 per car, or \$1M per year;
- Using black screws instead of color-matched painted screws on Mustang side mirrors saved \$5.40 per vehicle, or \$740,000 per year; and
- Skipping the black paint inside Explorer ashtrays saved \$0.25 per vehicle, or \$100,000 per year.

Schwartz also reported that Breyers ice cream had a manufacturing problem with the cellophane cover sheet inside the carton's top flap. Each rectangular sheet was stamped with "pledge of purity" that had to be centered over the ice cream. The centering process caused many manufacturing problems. Replacing the pledge with a repeating Breyers' leaf pattern that read "all natural" eliminated the process of centering the cellophane sheet and the need for precision cellophane trims on the assembly line, saving hundreds of thousands of dollars (Schwartz, 1996).

D.37. Case Study 37 - Producibility Expert Program



Producibility Elements Highlighted:

Primary: 4.1 Conduct Producibility Engineering Review

Secondary: 1.2 Organize for Producibility

Lockheed Martin, Government Electronic Systems (LM-GES) uses Producibility Experts and other technical experts to conduct design reviews and provide the best technical solution against requirements, producibility, standardization, and life-cycle cost criteria. The design review process consists of Concept, Implementation, and Pre-release reviews. To improve the first-pass success rate, the Design Review Team includes experts from Engineering, Operations, Sourcing, Quality, and Program Management, as well as the Producibility Experts.

The Producibility Expert Program was initiated in 1990 to address problems related to attrition. To maintain and advance the technical expert base in commodities, LM-GES established a recognized system of experts to convey both lessons learned and current processes to the design community to improve the total cost performance of new designs. The Producibility Expert's role is that of consultant and design reviewer inserted into the design process prior to Design Review. This practice has lowered the Drawing Change Rate.

Benefits of this program include the ability to contact experts on call for design engineering; the early insertion of process information and lessons learned into the design process; and manufacturing releases that are clearer and more producible.

D.38. Case Study 38 - Producibility Review in Product Manufacture

Producibility Element Highlighted:

4.1 Conduct Producibility Engineering Review

Lockheed Martin Tactical Aircraft Systems (LMTAS) in Ft. Worth, Texas applies an Integrated Product Team (IPT) review approach in its producibility program. The producibility review integrates the evaluation of the product with the tools and processes used to create the product. LMTAS calls this collection of data the Build-to-Package (BTP), which includes the product design, tool design, numerical control program, work instructions, and any other data required for production. All ingredients of the BTP are reviewed against each other before design starts and periodically during the BTP creation process. At its completion, the team again reviews all items against each other for producibility. Only then is the BTP released for production of the tools and hardware.

D.39. Case Study 39 - Poka-yoke: Mistake-Proofing the Process



Producibility Element Highlighted:

4.2 Error-Proof the Design

United Electric Controls (UE) applies Poka-yoke (mistake-proofing) principles to prevent and detect defects in its manufacturing processes. The procedure typically incorporates straightforward, simple tooling fixtures to ensure that various assemblies can only be assembled in the correct manner.

Poka-yoke prevents or detects problems before additional value is added to the parts as well as eliminates subsequent inspection steps to determine if the parts were correctly assembled. The process includes a series of questions regarding a defect such as:

- What was wrong?
- When was it discovered?
- What were the standard elements involved in making the part or assembly?
- What mistakes or errors were made?
- Why were the mistakes made?

This information is used to generate ideas on possible solutions to the problem. For its assembly fixtures, UE uses Poka-yoke devices such as limit switches, assembly templates or counters, and strategically placed pins or sensors on fixtures. Visual aids, detailed equipment set-up sheets, and in-process final assembly checks also aid the Poka-yoke process to ensure that the part was correctly assembled before it leaves the workstation.

UE's fixtures continue to go through the Poka-yoke process as assembly problems are noted. In addition, employees continue to identify other workcells where similar fixturing can be used to eliminate assembly problems.

D.40. Case Study 40 - Modeling and Simulation



Producibility Element Highlighted:

4.3 Optimize Manufacturing

Lockheed Martin Tactical Aircraft Systems (LMTAS) in Ft. Worth, TX, has bundled hardware and software into a toolset for modeling and simulating manufacturing processes during design in preparation for production. LMTAS is using modeling and simulation to integrate its design, manufacturing, and business data systems into a common information environment. This integration provides a common data path between functions and enhances evaluation of complex design, manufacturing, and business concepts during all phases of the product's life-cycle. Factory layout, functional verification of tools, interference detection of assemblies, and manufacturing process concept development are tied together by a three-dimensional solid model.

Workstations, PCs, and software tools, such as AUTOMOD, Advanced CAD (ACAD), ERGO, Computer-Aided Three-Dimensional Interface Applications (CATIA)/Computer Mock-up (COMOK), Excel, and SLAM, provide manufacturing process simulation capability used in product design. Operational simulations of flight, carrier operations analysis, and visualization of flight recorder data are also used. Networking and solid modeling of the product in CATIA/COMOK provide a common path for information sharing and simulation. An organizational realignment which integrated manufacturing engineering tasks into the design department provide early awareness and leverage of manufacturing issues in product design. Tooljigs and fixtures concepts are developed and functionally simulated during advanced design to highlight configuration or concept problems. Weight and cost data can be reviewed to trade options, or detailed part configuration information such as radii can be evaluated for economical machining. Solid modeling of products, parts, and processes allow fit checks and evaluations of interferences and ease of assembly using COMOK. High level assembly efforts are simulated using discrete event simulation software (SLAM) to assess efficiency and highlight improvement opportunities.

The traditional method of manufacturing allowed very little cross-functional technical interface. The virtual manufacturing method provides a simultaneous interface between all technical disciplines and provides better communication of complex designs, manufacturing, and business concepts. Results are shorter product cycle times, lower development costs, improved quality, and more team ownership.

D.41. Case Study 41 - Factory Process Modeling and Simulation



Producibility Elements Highlighted:

Primary: 4.3 Optimize Manufacturing

Secondary: 2.1 Understand Current Process Capabilities (Company and Supplier)

3.3 Perform Trade Studies on Alternative Product and Process Designs

Northrop Grumman's Simulation and Virtual Manufacturing Tools team developed Factory Process Modeling and Simulation for some sections of the F/A-18 C/D assembly line. Through modeling and simulation, the company can continuously make improvements in quality and productivity, and evaluate new ideas, methods, and actions. Simulation tools can develop utilization profiles for resources; allow Integrated Product Teams to plan and analyze possible scenarios; predict production system behavior without disrupting ongoing operations; and identify processes where lean manufacturing practices will have the greatest impact.

As a test case, the team modeled the production operations of Cost Center 2510 (the Aft Center Fuselage Assembly). First, the team developed an assembly precedence model using Microsoft Project. This model

identified critical paths and opportunities for shortening the process cycle. Next, the model was fine-tuned via input from the mechanics working on the production line. Then the model was exported from Microsoft Project, translated, and imported into the Autosimulations Autosched software. A graphic simulation model of the Center was developed in the Autosched software. To populate the model, data was downloaded from 35,000 lines of production scheduling and the Integrated Management, Planning, and Control for Assembly system. Other types of data used in the simulation included operator data such as quality certifications, efficiency/experience, difficulty of tasks, and job preference qualifications. The team devised and ran numerous simulation experiments to vary the parameters (e.g., operator efficiency, number of operators, workshift hours, number of nonconformances, quality assurance processing time).

Through this modeling and simulation effort, Northrop Grumman identified opportunities for a 10% cost reduction in the Center's operation. Simulations were also used to determine the best course of action to deal with part shortages occurring at the Center. The company was able to define and analyze possible scenarios for handling the shortages in a three-hour timeframe. Northrop Grumman is now applying its Factory Process Modeling and Simulation to other production areas within the company.

D.42. Case Study 42 - Process Variability Reduction



Producibility Elements Highlighted:

- Primary:** 2.1 Understand Current Process Capabilities (Company and Supplier)
5.1 Measure Processes

Northrop Grumman implemented a Process Variability Reduction (PVR) system to improve the manufacturing processes on its F/A-18 C/D and E/F programs. The PVR system consists of a Statistical Process Control (SPC) system, a Manufacturing Process Performance System (MPPS), and a Manufacturing Process Data Base (MPDB). All of these components are computer-based, open-system architecture tools used by management, the engineering design staff, and the shop floor. In 1992, market competition encouraged Northrop Grumman to begin SPC pilot projects. Since that time, the company's full SPC system has gained control of process variabilities and significantly reduced or eliminated the associated costs of nonconformance and rework.

The SPC component of the PVR system tightly tracks process variability, which allows Northrop Grumman to understand where problems arise and to address them immediately within that shift. Accessible in real time to all employees, the on-line SPC system is considered a certifiable skill for shop floor mechanics and is a requirement for completing any work. A lapsed certification in SPC or any other skills will prevent a mechanic from performing any work until certification is reinstated. All mechanics, engineers, mechanical engineers, quality assurance personnel, supervisors, and upper management must complete SPC training.

SPC usage has also reduced rework and administrative costs substantially. On the F/A-18 C/D program, the average number of defects per production unit decreased 79% between 1995 and 1996. Cycle time, hours per unit for rework, and administrative actions associated with those defects decreased 70% between 1995 and 1996, despite a 20% increase in production rate. Even further benefits are now being seen with the new E/F program. The use of an entirely CAD-based design for all parts and tooling has improved tolerances. However, Northrop Grumman does not monitor all of its processes by SPC. The decision-making process to identify which process should be applied to the PVR system includes pareto charts.

MPPS encompasses the SPC data collection on the shop floor as well as the data analysis and reporting used daily in IPT meetings. This data enabled Northrop Grumman to switch from 100% inspection to a sampling method, reducing inspection times by 70% per unit. Sampling rates are based on the higher figure from either process performance data or the American National Standards Institute (ANSI) recommended values.

MPDB, the on-line deliverer of process capability data, includes a catalog of all Process Codes, Process Specifications, Assembly Process Work Instructions (APWIs), and Process Performance Data. Northrop Grumman tracks processes not parts. Process Codes are cross-referenced to Process Specifications which, in turn, correlate to specific Cost Centers on the shop floor.

APWIs are electronically available on the shop floor. These work instruction documents support individual Assembly Line Operation Orders (ALOOs). ALOOs tie together all requirements (e.g., reference drawings, manufacturing notes, work instructions, inspection items) to complete a process that typically requires six to

eight hours per shift. Tool and Equipment Kits are also kitted to specific ALOOs. These kits include all power and hand tools and parts for a process.

Northrop Grumman continues to track process data through its PVR system. The company has gained improved manufacturing processes and cost savings for the F/A-18 C/D and E/F programs. In addition, the PVR system has enabled Northrop Grumman to earn the McDonnell Douglas Preferred Supplier Silver Rating.

D.43. Case Study 43 - Using Metrics to Drive Process and Quality Management



Producibility Elements Highlighted:

- Primary:** 2.1 Understand Current Process Capabilities (Company and Supplier)
5.1 Measure Processes

Several years ago, Raytheon Missile Systems Company (RMSC) realized its manufacturing capabilities were not meeting the customer's cost expectations. As a result, the company began efforts to improve its processes and turned to metrics as a way to drive process and quality management. Initially, process owners and general managers tracked the deployment of engineering disciplines across their programs as a way to increase the awareness and use of process improvement metrics. Now, metrics are required for all programs as a part of RMSC's Integrated Process Architecture (IPA).

RMSC starts every program with standard IPA processes, and tailors them to individual needs. Laboratory managers review the tailored processes to ensure that critical elements of each process are maintained. The Integrated Product Team program, responsible for the tailored process, identifies and collects standard and Six Sigma metrics on the key processes for continuous assessment across various engineering disciplines. Standard metrics include cycle time, defect detection, design-to-cost, risk mitigation, design reviews, top production issues, design reuse, staffing, and training. Although all processes do not require a Six Sigma level, RMSC uses these metrics to identify sources of defects, and to increase producibility, design for manufacturability, and communication among engineering disciplines. This approach reduces cycle time and improves costs, performance, and schedules for individual programs. Monthly process reviews are used across the enterprise.

In addition, RMSC tailored the Software Engineering Institute's Capability Maturity Model to be applicable to all mechanical, electrical, and software design processes. By identifying the maturity level of a process, RMSC can determine the associated estimates for risk level, producibility, and quality capability. Maturity of processes is another way for the company to benchmark against the rest of industry. RMSC also measures and analyzes in-process defects to identify defect type, occurrence pattern, and trends at the project and organization levels; identifies and resolves systematic problems; and addresses project-specific problems early in the life-cycle to reduce rework costs. By using process sigma levels and in-depth understanding, designers can develop new processes and estimate sigmas. Actual sigmas are compared to predicted ones, which enable RMSC to quickly resolve new issues. Although existing programs may not reach the maturity levels of newly planned ones, RMSC's continual use of metrics enables all programs to address process improvement and achieve reduced cycle times and/or defect levels.

Appendix E

INDUSTRY APPLICATIONS AND TECHNIQUES

This appendix contains three examples, submitted by industry, that highlight some of the producibility system elements described in these guidelines.

Appendix E.1: Addresses the use of Integrated Product Teams (IPTs), design for manufacture, and the Six Sigma technique to conduct design tradeoffs for the U.S. Army's Long Range Advanced Scout Surveillance System.

Appendix E.2: Presents a design-to-requirements process developed to enhance product definition while simultaneously reducing acquisition costs. This process addresses producibility from the very beginning of the product's life-cycle.

Appendix E.3: Presents a producibility program implementation checklist that provides insight into the sequence of typical design reviews.

E.1. Customer Satisfaction Through Design For Manufacture / Assembly And Six Sigma Analysis

Introduction

In 1997, the Raytheon Systems Company was contracted by the U.S. Army to design and build major portions of the Long Range Advanced Scout Surveillance System (LRAS3), shown in Figure E.1. The LRAS3 is a long-range reconnaissance and surveillance scout system operable in both a stationary vehicle and a dismounted configuration. It is a 24-hour, adverse weather operational, line-of-sight sensor system that provides real-time acquisition, target detection, target recognition, target identification, and far target location information to cavalry scouts. The system contains the following major components: forward looking infrared sensor, day video camera, eyesafe laser rangefinder, and the Global Positioning System (GPS).

Upon contract approval, an Integrated Product Team (IPT) was incorporated for implementation of concurrent engineering approaches to influence, as early as practical, an affordable and compliant system design. The IPT membership included various engineering disciplines, such as design, producibility, quality, reliability, maintainability, logistics, and safety, to identify critical factors, components, cost drivers, and processes. Producibility analyses were performed during each tradeoff determination to decide which product characteristics contributed to item/assembly process variability and cost. As a result, the IPT proposed and implemented alternatives for controlling or eliminating these process and cost variations. Consequently, the Global Positioning System Inclinometer System (GPSIS) cover, which was

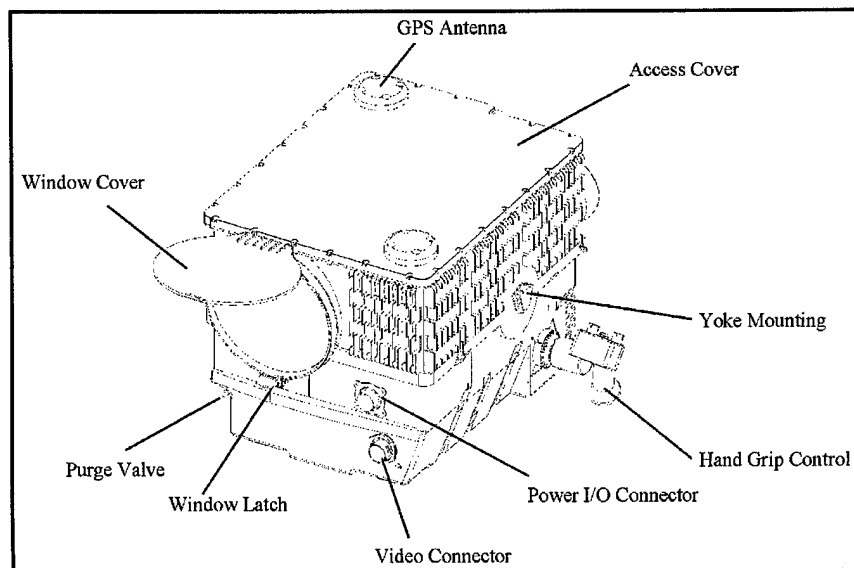

Figure E.1 - Long Range Advanced Scout Surveillance System

one of many tradeoff analyses performed by the LRAS3 IPT, was highlighted to demonstrate how Design For Manufacture/Assembly (DFMA) and Six Sigma processes can significantly impact customer satisfaction by minimizing cost drivers and schedule while maximizing performance.

Objectives

When designing products for military applications, customer concerns are cost, performance/quality, and schedule. Performance expectations for the LRAS3 were high because the lives of fielded soldiers depended on the system. The IPT members maintained that critical performance criteria should not be sacrificed for cost or schedule. The customer demands a product that meets all three critical goals.

GPSIS Cover Assembly Selection

The main purpose for focusing on DFMA and Six Sigma trade studies was to identify and minimize cost and schedule drivers, as well as to enhance system performance. Through analysis and experience, several complex mechanical/electrical sub-assemblies were identified by the IPT as high risk in cost and performance. The GPSIS

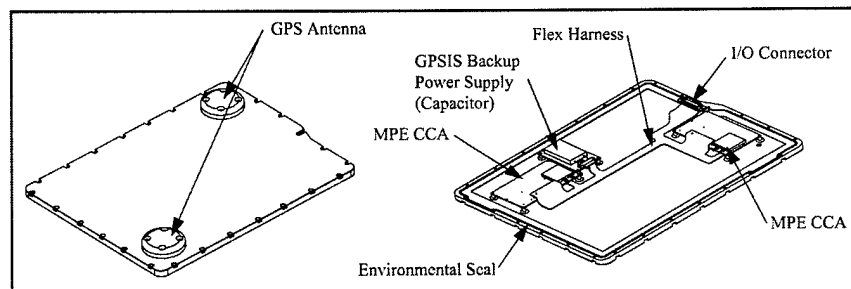

Figure E.2 - GPSIS Cover Assembly

Cover Assembly, shown in Figure E.2, was chosen for this project because it presented the IPT with a unique design challenge relative to performance and cost. The GPSIS Cover Assembly design incorporated the use of Global Positioning Antennas, Circuit Card Assemblies (CCAs), and a conductive ground plane with critical flatness requirements. Concerns were raised with the ground plane, antenna spacing, tolerancing, integration and testing, thermal isolation, and cover fabrication design approach. Consequently, the GPSIS Antenna/Ground Plane was considered one of the largest risk areas on the system.

Design Performance Requirements

The major design requirements were as follows:

- GPSIS Flat Ground Plane - Flatness +/- 1 degree between the two GPS antennas
- Lightweight construction
- Thermal isolation of MPE CCAs from solar load
- Environmental seal on antennas and sight
- Conductive ground plane for EMI/RFI
- Extreme rigidity
- Cost and schedule
- Tooling cost minimization

Design IPT Membership

Gretchen Anderson	Non-Metallics Engineer
Bill Bracken	Metal Fabrication Producibility
King Burgess	Mechanical Engineer
Bob Cunningham	Mechanical Engineer
Michelle Holly	Assembly Methods and Tooling Engineer
Terry Patterson	Quality Engineer
Winston Stallings	Lead Mechanical Engineer
Paul Zimmermann	Lead Systems Producibility Engineer

Design Methodologies and Tools

The IPT Design Team, whose overall process is shown in Figure E.3, used the following methodologies/tools during the cover design:

- The team met frequently to discuss design options. Hand sketches were used to evaluate options and performance, and first pass DFMA and Six Sigma were performed on conceptual sketches. The team documented the pros and cons for each design concept.
- DFMA analysis was applied.
- Six Sigma analysis was used to evaluate performance tradeoffs.
- DFMA analysis was used to determine the best design approach and assembly cycle time.
- Timely cost/performance tradeoffs were considered.
- The design team met frequently with manufacturing and the assembly shop to identify the required tooling.

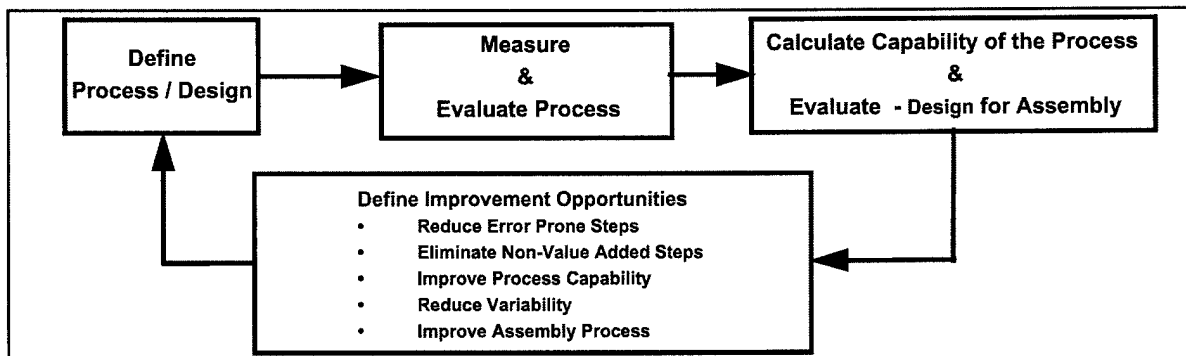

Figure E.3 - IPT Overall Process

DFMA and Six Sigma Principles

The IPT implemented the following DFMA and Six Sigma basic principles:

DFMA Principles

- Use modular subassemblies
- Provide accessibility
- Use multifunctional parts
- Standardize
- Avoid difficult components
- Minimize the number of parts
- Avoid special tooling
- Minimize the use of fasteners
- Minimize reorientations
- Use self-locating features

Six Sigma - 12 Basic Principles: Designing for Assembly

1. Minimize the number of parts
2. Minimize assembly surfaces
3. Design for Z axis assembly
4. Improve assembly access

-
5. Maximize part compliance
 6. Maximize part symmetry
 7. Optimize part handling
 8. Avoid separate fasteners whenever possible
 9. Provide parts with integral self-locking features
 10. Drive toward modular design
 11. Avoid mixtures of process technology
 12. Ensure specific piece part packaging compatibility with factory material handling and automation schemes

Design Evolution

Seven different design configurations were considered for manufacturing and assembly of the GPSIS Cover Assembly. Each option with a description and an illustration follows.

- **Design Option 1** was a machined casting with the insulation foam bonded to bottom side of cover.
- **Design Option 2** was a sheetmetal cover with welded aluminum flanges, mounts and insulation foam bonded to the bottom side of the cover.
- **Design Option 3** was a machined graphite composite lay-up with the insulation foam bonded to the bottom side of the cover.
- **Design Option 4** was a composite cover using prepreg, aluminum flanges, and mounts bonded in place during the lay-up. The laminated cover assembly had insulation foam between two prepreg layers.
- **Design Option 5** was a composite cover using aluminum top skin, flat aluminum bottom skin, insulation foam, four stamped aluminum flanges, eight Shur-lock inserts, and 12 Click Bond inserts. The laminated cover assembly had insulation foam between two aluminum skins.
- **Design Option 6** was a composite cover using flat aluminum top and bottom skins, insulation foam, four machined aluminum flanges, eight Shur-lock inserts, and 12 Click Bond inserts. The laminated cover assembly had insulation foam between two aluminum skins.
- **Design Option 7** was a composite cover using flat aluminum top and bottom skins, insulation foam, machined RPM cast aluminum flange, eight Shur-lock inserts, and 12 Click Bond inserts. The laminated cover assembly had insulation foam between two aluminum skins.

Design Results

The LRAS3 design IPT used DFMA and Six Sigma analyses to provide a solid basis for reducing variation, maintaining process control, minimizing cost drivers, and maximizing performance. The Army customer demanded higher quality and performance at cheaper prices with less time to deliver. DFMA and Six Sigma were used to ensure that the designs were manufacturable and that the production processes were capable, predictable, and in control. The following analyses results are highlighted as well as the impact on the design for the GPSIS Cover Assembly.

Process / Tools Approach

- IPT Team Meetings - DFMA / Six Sigma design iterations on seven design options
- Listed pros and cons of design options
- Worked with the functional shops
- Documented decisions and trade studies
- Applied the Boothroyd & Dewhurst, Inc. Design for Assembly tool
- Used Six Sigma analysis tool
- Applied Sigma roll up

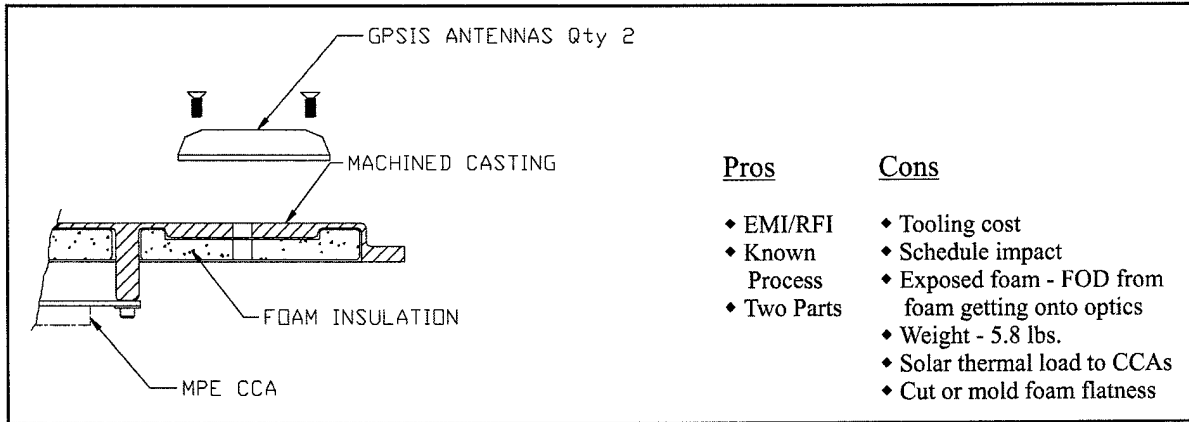

Figure E.4 - Design Option 1

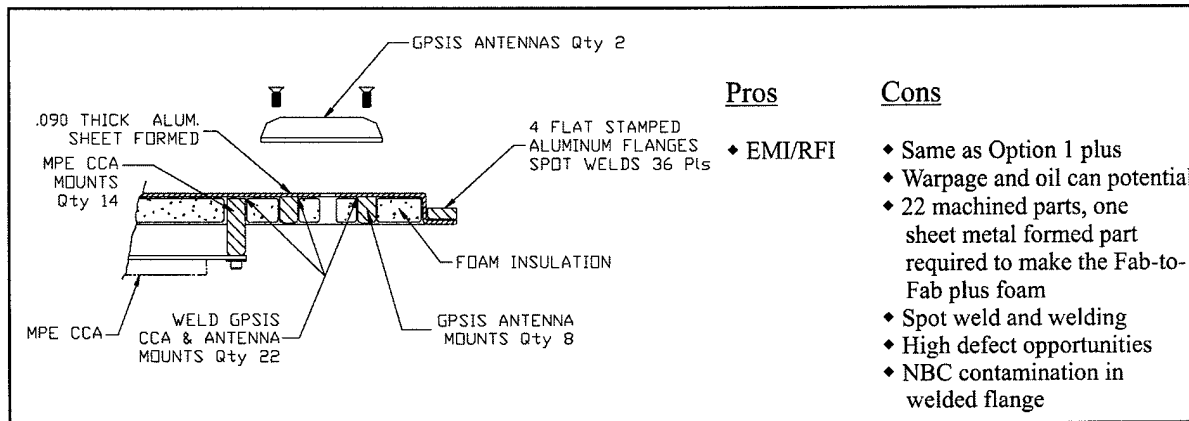

Figure E.5 - Design Option 2

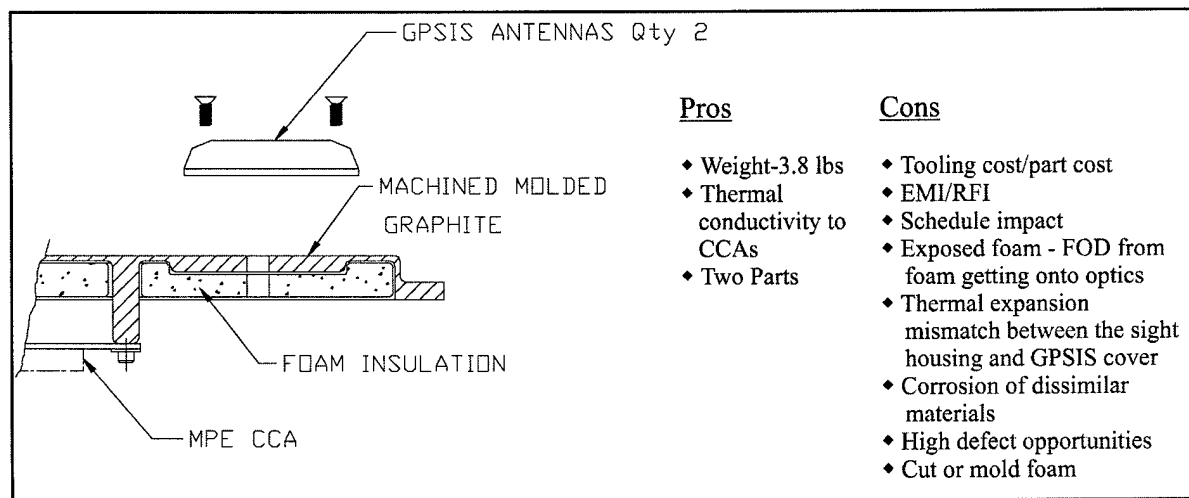

Figure E.6 - Design Option 3

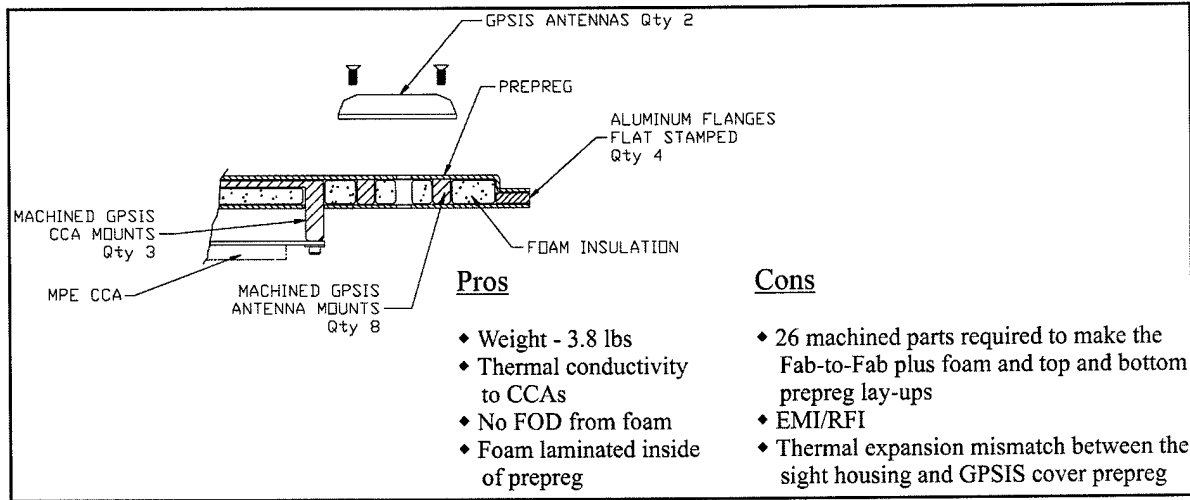

Figure E.7 - Design Option 4

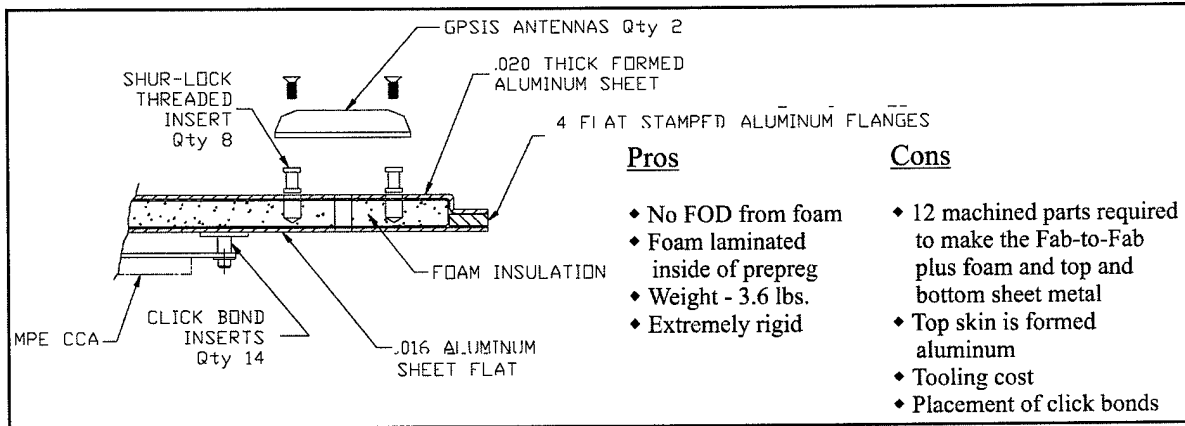

Figure E.8 - Design Option 5

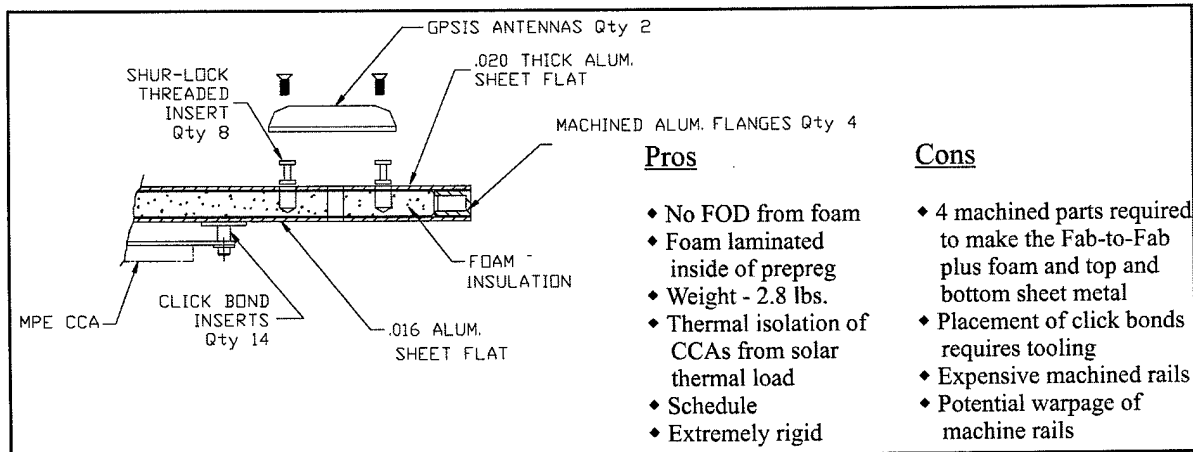

Figure E.9 - Design Option 6

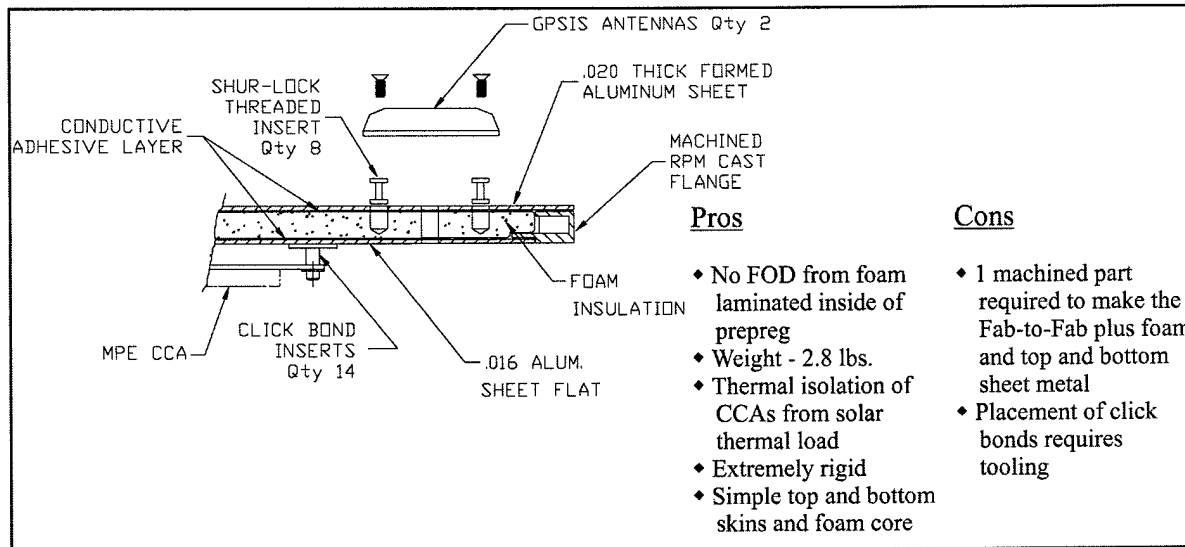

Figure E.10 - Design Option 7

Results of DFMA and Six Sigma Design Recommendations

The DFMA and Six Sigma analyses had a significant impact on cost, quality, and schedule. As a result, the following design recommendations were incorporated into the design:

- Fabricated parts were simplified to make the GPSIS Cover Assembly.
- A foam core was used as a structural member of a composite cover.
- The GPSIS Cover Assembly was made up of four major fabricated parts. The top and bottom skins and the foam core were a simple design with a Sigma value greater than six.
- The rubber plaster mold casting required minimal machining as it was designed before assembly with the cover. Only three mill cuts were needed to make the surface flat.
- Off-the-shelf mounting hardware was used. Eight Shur-lock inserts were used, as well as 12 Click Bond inserts for mounting the GPSIS Antennas and the CCAs. Historically, machined mounts would be used that would be bolted or welded in place to mount the CCAs and the Antennas.
- Composite laminate used a foam core, eliminating FOD from foam and resulting in a rigid structure.
- The system was shielded from electro-mechanical interference/radio frequency interference.
- The cover was made flat to minimize tooling cost.
- Marking was minimized. "Bagged and tagged" was used where possible.
- Wherever possible, hardware standardization was applied, using 4-40 Allen head cap screw type hardware to minimize issues with torqueing of the screws, and one drive type was used to minimize tooling required to assemble.
- The need for adding a solar shield assembly was eliminated.
- Silk screen or label assembly part number on main housing was used on assemblies to reduce rubber stamping effort at the higher levels (label marking was not acceptable for exterior surfaces).
- Used rubber stamp Manufacturer Serial Numbers (MSN) at the assembly level. Historically, the company would mark every fab part and assembly that goes into a system, using the rubber stamp process, which required almost one hour. To minimize the cost of the system, only assembly MSNs on the assemblies were marked.
- Marking height (0.109" through 0.140") was used to reduce smearing, smudging, etc., which in turn drove up the defect rate, affecting the part's Sigma.

- Silk screen marking at fabrication levels was used to reduce the defect rate and assembly cycle time.
- Foam core was used as a structural member of a composite cover, with an aluminum top and bottom skin. Initially, the design team was looking at using a casting or a sheetmetal weldment to isolate the insulation foam bonded to the bottom side of the cover. With age, the exposed foam would cause FOD or foam particles getting onto optics. These particles would degrade the optical performance of the system; therefore, by laminating the foam into the cover the team alleviated the potential damage to system performance.

Performance and Quality

System performance and quality were clearly impacted by the DFMA and Six Sigma analyses and showed the following improvements:

- Sigma Improvement

<u>Option 2</u>	<u>Option 7</u>	
3.64 Sigma	4.83 Sigma	(1.19 Sigma delta)
6.62 DPU	0.17 DPU	(6.45 DPU delta)
- Weight 2.8 lbs., approximately (3 lb. reduction)
- Thermally isolated CCAs (31 degree delta, top to bottom)

Predicted Cost Savings

- GPSIS Cover Assembly (Production Cost Savings)
 - 55% reduction in Production Cost by implementing Design Option 7 versus Design Option 2
- GPSIS Cover Assembly (Defect Cost Savings - DPU Predictions)
 - 97% reduction in Repair/Rework Avoidance Cost by implementing Design Option 7 versus Design Option 2

Bottom Line

Projected cost savings over the program life is in excess of \$2M.

Authors

Paul A. Zimmermann
Raytheon Systems Company & Texas Instruments, Inc.
McKinney, Texas

Mr. Zimmermann, Lead Systems Producibility Engineer, has worked for Raytheon since the acquisition of the Defense Systems and Electronics Group of Texas Instruments by Raytheon. Since then, he has been assigned to the LRAS3 program as the Lead Systems Producibility Engineer. He has conducted several Design for Manufacture and Assembly working sessions, and was instrumental in the design of the LRAS3 GPSIS Cover Assembly.

Before assignment on the LRAS3 program, Mr. Zimmermann worked for Texas Instruments for nineteen years, with his last assignment in the Digital Imaging Group working on the Business Projector, where he was instrumental in the productionization redesign of the Business Projector. From 1994 to 1995, he was assigned to Personal Productivity Products working on the TM5000 and the TM6000 Notebook Computer design. He previously worked in Systems Groups, supporting such programs as HARM, Javelin, LAVAD, and other military systems.

Terry A. Patterson
Raytheon Systems Company & Texas Instruments, Inc.
McKinney, Texas

Mr. Patterson is currently the Lead Quality Engineer for the Long Range Advanced Scout Surveillance System and Horizontal Technology Integration Forward Looking Infrared programs. He effectively conducted Six

Sigma product design improvement efforts for the Long Range Advanced Scout Surveillance System and Horizontal Technology Integration as well as other surface combat and Forward Looking Infrared programs.

Mr. Patterson currently holds certifications as a Quality Engineer through the American Society for Quality and as a Six Sigma Black Belt through Raytheon Systems Company.

E.2. Producibility Design-To Requirements: Helping Enhance Product Definition

Introduction

When implemented by an Integrated Product Team (IPT), a streamlined requirements definition process can produce significant benefits for both customer and industry while affecting time to market and lean enterprise endeavors. Producibility Design-To Requirements (PDTRs) can result in enhanced product definition while simultaneously reducing acquisition costs. Because PDTRs are applicable to development programs, Engineering Change Proposals (ECPs), or military Service Life Extension Programs, this technique is particularly effective when augmented by knowledge-aided techniques, such as those supported by the Joint Continued Acquisition and Logistics Support (JCALS) environment.

Producibility can be viewed as the domain of manufacturing events directly relatable to, and dependent upon, design attributes, and PDTRs result in design attributes. A design lacking in producibility characteristics is the consequence of a broken process in which PDTR development did not play a significant role. Ideally, a smooth transition of requirements between the customer and contractor is evidenced by a clear understanding of those requirements, specifically those of the end user, such as the next workstation, flexible manufacturing cell, or military depot. This effort will avoid over reliance on the traditional design review process (Preliminary and Critical Design Reviews), or a generic, after-the-fact producibility assessment approach.

The specific value of the PDTR approach is in its ability to maximize the individual IPT member's expertise and harmonize that with information system technology. A typical IPT member brings knowledge and experience to the team; however, if that member also had access to knowledge-based systems, his personal expertise could be significantly enhanced by external qualitative and quantitative information. The PDTR approach resembles the requirements generation process which starts with top level requirements that culminate in lower level, detailed requirements. The particular value of this to the IPT is that these PDTRs must then "pass muster" with the systems engineering and design organizations as they relate to their understanding and implementation potential. Within the IPT, the PDTRs are discussed, evaluated, and synthesized—the PDTR serves as the common requirements link for producibility. Fundamentally, the PDTR process precedes the traditional design review approach because its basis is more proactive. It therefore affords the designer more opportunity to integrate PDTRs into his creative process.

A successful producibility program should integrate supportability to help achieve production and maintainability objectives and goals. The integration between producibility and supportability engineering occurs within systems engineering, where the product is defined with the desired manufacturing and support characteristics. Because many producibility enhancing design features are also applicable to supportability, information relative to supportability is addressed here.

Technical Approach

To achieve the desired producibility features resulting from PDTRs, a significant amount of homework must be accomplished early, including the development of a formal lessons-learned database. When generating PDTRs, the homework should focus on identifying producibility drivers and analyzing manufacturing events from piece part fabrication to flight test. The PDTR is strengthened by input from the domain expert who in turn tailors the historical data through analyses related to the specific project. The domain expert is a selected candidate from either the engineering or the manufacturing organization. This expert most likely has the most knowledge in a specific area such as a machining process, setting up experiments, or understanding the capabilities of Computerized Numerical Control machinery.

Product definition consists of a flowdown of top-level to detailed requirements. These are available through an Integrated Product Definition Data Base (IPDDB), a critical element of the development effort in creating

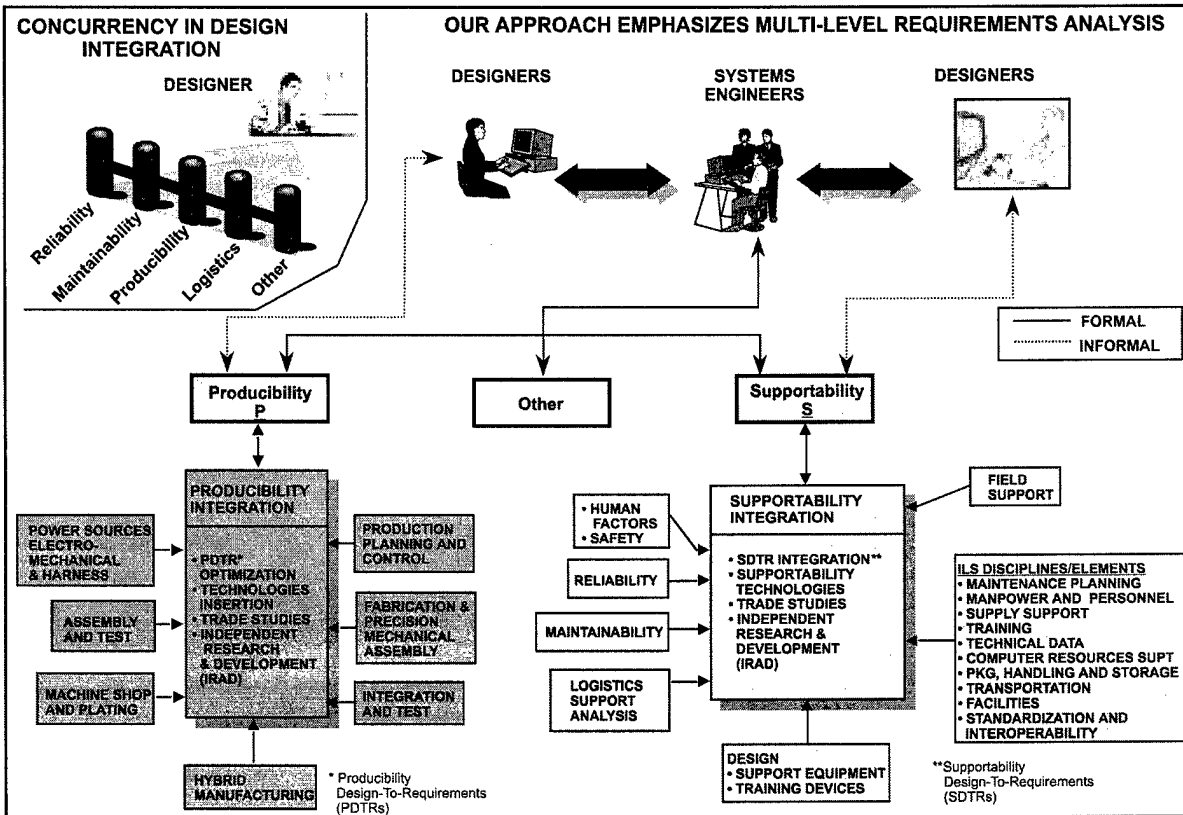

Figure E.11 - Concurrent Engineering Approaches

design-to requirements. The IPDDB is on the producibility engineer's workstation that converses with the designer's CAD terminal – this link helps ensure that the PDTRs are properly conveyed (Figure E.11). The Producibility Engineer essentially represents a selected group of manufacturing shops. Communication with the designer involves stating requirements in the timely design-to language while leaving indigenous producibility terminology transparent. This open architecture requirement generation capability promotes growth and team interaction, and ensures end user satisfaction.

Typically the manufacturing information database is an internally developed capability or exists in Material Resource Planning models. Research suggests that producibility-enhancing design features are also applicable to supportability with many instances of requirement harmony between producibility and supportability. Although the terminology defining events is different between producibility and supportability, the outcome is a discrete design-to requirement, and many events are similar among both disciplines.

TRW in San Diego, California developed its Knowledge-Aided Producibility Analysis Technique (KPAT) based on the above concepts. Using KPAT, the designer has the option of informally viewing lessons learned and the PDTRs to achieve familiarity with those requirements. At the formal level, the designer is provided PDTRs which have been synthesized, subjected to trade studies, and optimized by systems engineering. KPAT outputs either to mechanical CAD or to E-CAD. Design activities and responses can be monitored through built-in utilities that provide a historical trail of the interaction. At TRW, as requirement definition and the associated homework are being completed, JCALS capabilities are being explored and can be used to transmit selected files to the customer for continuous online viewing and comments. This closed design loop, open architecture requirement generation capability enhances rapid information flow and IPT interaction.

Contractor Participation

Two contractor efforts occur before product definition can take place. First, the contractor develops product requirement development procedures which echo those of the customer. Ultimately, the customer and the contractor requirements appear as though developed using similar techniques. (The customer may not necessarily articulate in-depth PDTRs in the current specification reform/Performance Based Business environment. However, the contractor must develop PDTRs internally so that cost and schedule goals can be achieved.) Secondly, it is important that both customer and contractor teams participate openly at some level in the Request for Proposal response to coalesce an understanding of its requirements, another example of an IPT involvement. This will ensure that the desired system design configuration reflects user requirements. It will also ensure that contractor management has made an obvious commitment to the IPT's efforts.

Information Architecture

The foundation for much of the information system technology at TRW was the JCALS initiative and from EDM capabilities. JCALS lends its relevance for producibility in data exchange and transfer, systems database structures, information processing, and delivery of deliverables in digital format. Without a JCALS-like capability and concurrent engineering processes, the IPT's effectiveness is sub-optimal in a highly competitive environment.

The producibility and supportability information architecture have a common denominator, the Information Node which can be the Work Breakdown Structure (WBS) or the Work Unit Code (WUC) for support aspects, as shown in Figure E.12. All information pertinent to the producibility or supportability characteristics can be readily captured in a WBS/WUC data element. This architecture enables the producibility engineer to capture lessons learned and develop the corresponding PDTRs. Included would be an engineering history as well as the lessons learned to provide comprehensive traceability of the new product lineage.

The integrated database, constructed from a combination of customer provided and internal information systems, accelerates an in-depth understanding of the nature of design-driven producibility requirements. This database must include not only the producibility characteristics of the prime hardware to its lowest indenture level (aircraft, train, commercial generator, etc.), but all the related manufacturing equipment which, in some cases, may be the real driver. For example, a sudden manufacturing equipment failure or out-of-tolerance condition can cause a serious schedule impact on the prime hardware, especially when failures occur during a critical stage of the manufacturing process. In that case, an organized approach focusing on the producibility elements, sub-elements, and information nodes is necessary; consequently, the sub-elements would include Facilities, Equipment, and Transportation, as illustrated in Figure E.12. By categorizing and linking the baseline with the project data as indicated through the cell characteristics, the manufacturing equipment issues can be nested in the same WBS that provides information for the prime hardware.

Studying the elements and sub-elements highlights that several levels of integration should occur before a requirement set is conveyed to the design organization, although subsequent design iterations are inevitable. But if done rigorously and in a knowledge-aided team environment using comparable techniques such as KPAT, the design should require minimal revisits and corrective ECPs.

The use of the WBS, product categories, or other means enhances product examination of the existing, comparative system, and genetic typing or characterization of design attributes for the project. As the data for both baseline (derivative, comparative) and the project (new, development, ECP) is assimilated, analyzed, and formatted, it acquires dynamic information attributes. These attributes may define areas such as surface features, hole sizes, or corner radii. Using JCALS information technology, these attributes are readily shared within the IPT. Added to this knowledge base is the input from the domain expert, who in turn tailors the historical data through analyses, such as trade studies or technology insertion, related to the specific project and its features. Consequently, a combination of manufacturing history and domain expertise engenders project design-to information development, while helping evolve a corporate memory bank. Information management, knowledge capture, and a dynamic system engineering environment can result in predictable and supportable products.

Data dictionary terms are intended to be quantifiable with respect to manufacturing events. For example, it should be possible to capture the frequency, duration, and cost of a particular event such as anodize. The shop work order may be a source of information that provides the frequency, duration and cost characteristics of that event. Augmenting the data dictionary, KPAT allows the data element directory to distribute, control, and manage each design driver or PDTR with respect to the previously mentioned information nodes.

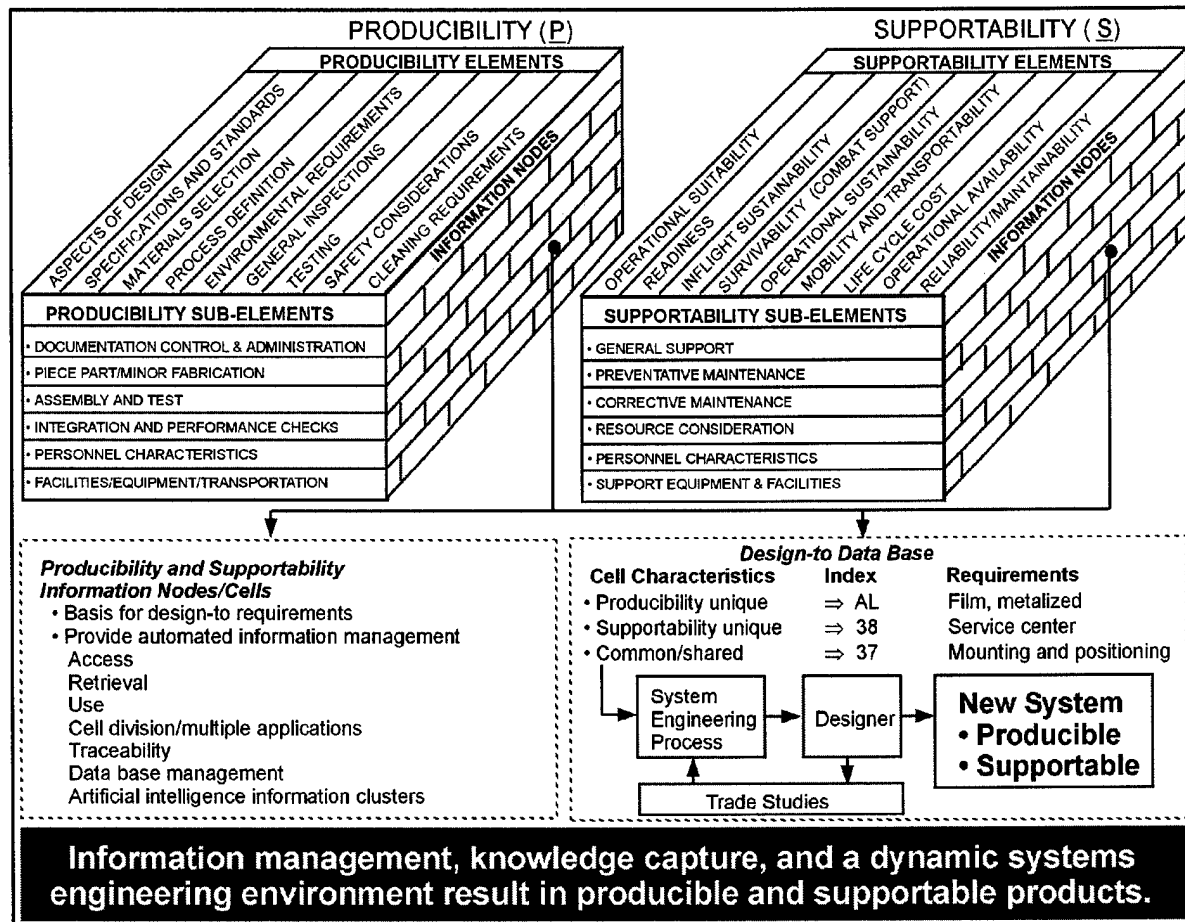

Figure E.12 - Lessons Learned and Design-To Requirements

Product Definition

For the KPAT technique, product definition essentially starts with the systems engineering process as outlined in the Defense Systems Management College Handbook: Systems Engineering. That handbook defines the various "ilities" such as reliability, maintainability, and transportability as systems engineering filters, and these are most likely represented by an IPT member. Product definition relating to producibility takes shape after the missions have been defined, "mission" representing that set of requirements which identifies what the product must do. For example, the aircraft and its systems must be able to fly a five-hour flight, to a certain altitude, and take pictures for geodetic research of certain ground features. That mission will determine some of the aircraft's vital characteristics, which then determine producibility approaches. So, if the aircraft is very light, then composite structure might be used.

Producibility definition which occurs through PDTR development is a reflection of those filters. PDTRs which extend to the lowest equipment levels will affect various systems configurations. These configurations, or fold-down of requirements, should be symmetric, consistent, and reflect vertical linkage within the WBS.

To distinguish between the disciplines, the data element dictionary defines each production event (approximately 500) and the responsible organization or discipline. For example, machining events belong to the machine shop, and composite lay-up events belong to the composite shop. Integration by the producibility engineer for each of these individual disciplines is essential and requires the producibility engineer ensure that each PDTR, associated with a specific manufacturing event (defined by the dictionary), causes its frequency function-duration-cost event to be definitely reduced. When there are instances where only a qualitative

requirement can be generated, the requirement is stated accordingly. Each level of the information architecture (elements, sub-elements, and information nodes) contributes to defining producibility for the various hardware indenture levels. The notional algorithm, presented in Figure E.13, defines producibility with respect to the information architecture and provides the means to conduct comparative analyses between the baseline and the project. The information architecture can be tailored to reflect a company's own producibility handbook.

Producibility and supportability can be defined by the following equations:

$$\underline{P} = F(f, d, c)$$

$$\underline{S} = F(f, d, c)$$

Where:

\underline{P} = Producibility, \underline{S} = Supportability

F = function of

f = event frequency, d = event duration, c = event cost

For example, manufacturing events range from anodize to Zyglol; support events range from access to winterize.

When the \underline{P} function approaches minima (the manufacturing events approach 0 for either f, d, or c), the respective manufacturing events have been successfully reduced through design interaction by PDTRs. (The designer must incorporate each PDTR into the design.) Because producibility and supportability requirements are often compatible from an "event" standpoint, these equations enhance cross-discipline uniformity in life cycle cost analyses and tradeoffs. It should therefore be relatively easy to trade off producibility against supportability at any WBS level for any combination of elements and sub-elements. This uniform formulation also accelerates the generation, tracking, and control of the design-to requirements.

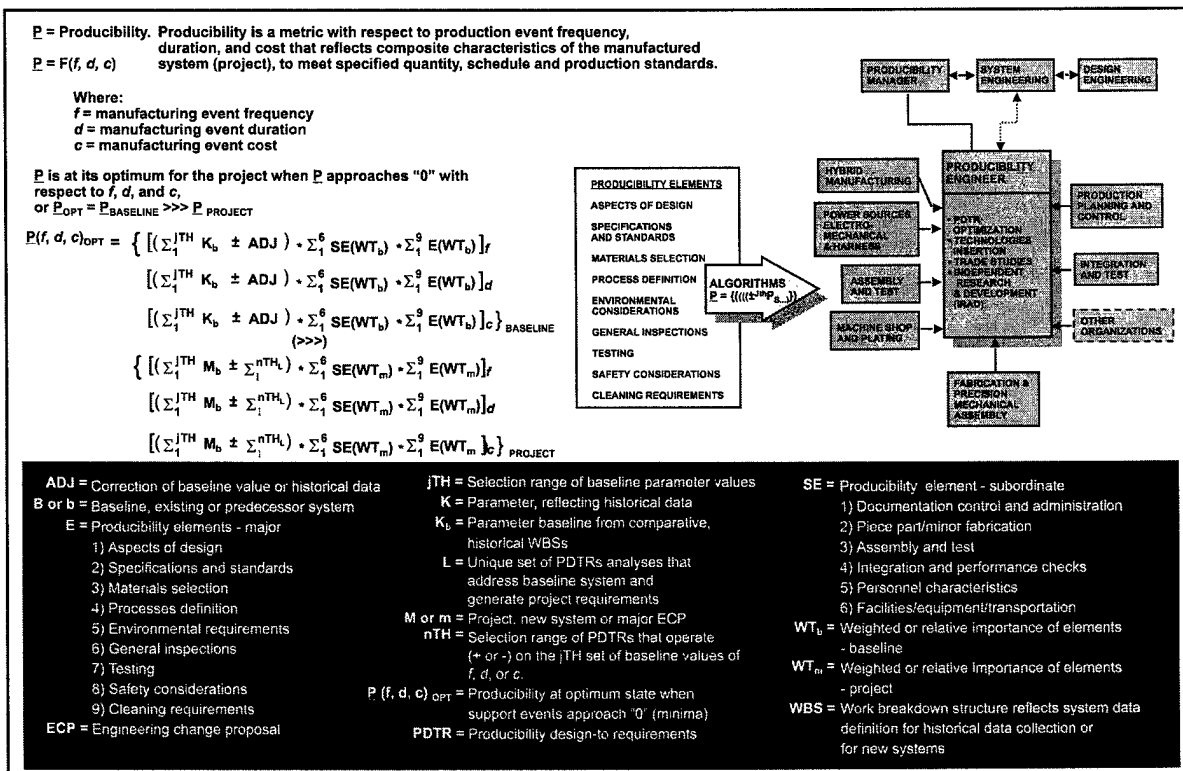

Figure E.13 - Algorithms Define Producibility Design Characteristics

By using the genetic-typing scheme inherent in the WBS, producibility and supportability data are readily accessible and manageable. It allows for effective analysis and comparison of seemingly unrelated design features that may impact either producibility or supportability. The simple equations above are integrated with the algorithm and are intended to provide not only a definitive correlation with design attributes through the PDTR, but also serve as the integrating function between producibility and supportability.

Although existing metrics such as Six Sigma have a special purpose, the purpose of the Producibility Metric $P = F(f,d,c)$ is to provide a means of establishing early design-to criteria at point of design in CAD rather than monitoring variations of processes during manufacture, and then accommodating those variations with other design changes, thereby compounding the problem.

Product definition includes the expressed issues and drivers of each organization, and each has a unique input that affects the system design. However, to avoid inundating the designer with conflicting design-to requirements, a systems engineering process is used to refine and balance producibility requirements. The information architecture ensures that each organization and its manufacturing events are represented. By committing to participate, the lessons learned and PDTRs must be updated for any new project.

The Producibility Engineering Top Ten Steps

Producibility engineering analyses apply the following steps, which are augmented by KPAT as shown in Figure E.14.

1. Establish baseline configuration of the product (usually done by systems engineering).
2. Review the predecessor, comparable item work orders, and manufacturing planning data, or results of experiments for technical difficulty or lessons learned.
3. Review statistical producibility drivers using Pareto techniques; identify drivers using the $P = F(f,d,c)$ parameters.
4. Interview manufacturing shops, assembly areas, and flight test with specific questions related to discoveries from tasks 2 and 3.
5. Develop detailed lessons learned from steps 3 and 4 and study their implications.
6. Integrate technical data, statistics, and interviews; develop initial PDTRs linked to the P function (presented in Figure E.14).
7. Optimize PDTRs with respect to production, schedule, Affordable Readiness criteria, and technological opportunities by conducting trade studies. Discuss with design team members and supportability engineer.
8. Finalize PDTRs; convert to spec language but allow freedom of design.
9. Update or negotiate PDTRs with systems engineers and designers.
10. Incorporate PDTRs in the system spec or ECP via the Technical Data Package (TDP). This is the final step in the PDTR development process.

As an example, to achieve an integrated, balanced design for producibility, the use of trade study models provides the desired optimization based on producibility objectives. A similar approach is taken by supportability engineering in that each "ility" such as reliability, maintainability, packaging, and transportation is optimally represented by integrated Supportability Design-To Requirements (SDTRs). The results of this first level requirements optimization are further integrated by systems engineering with other key aspects of the design, such as survivability, lethality, life-cycle costing, and performance, to ensure top level requirements integration.

New technology introduction also needs to be viewed from a producibility engineering perspective. It is therefore essential that producibility engineers participate in the technology development so that once the technology has evolved, it can also be produced economically. Technology development provides an opportunity for producibility influence, as shown in Figure E.15. When the technology is embryonic, technology experiments are observed with respect to selected criteria such as failures/successes, and PDTRs are generated to integrate producibility considerations. A detailed producibility analysis is conducted which addresses a variety of

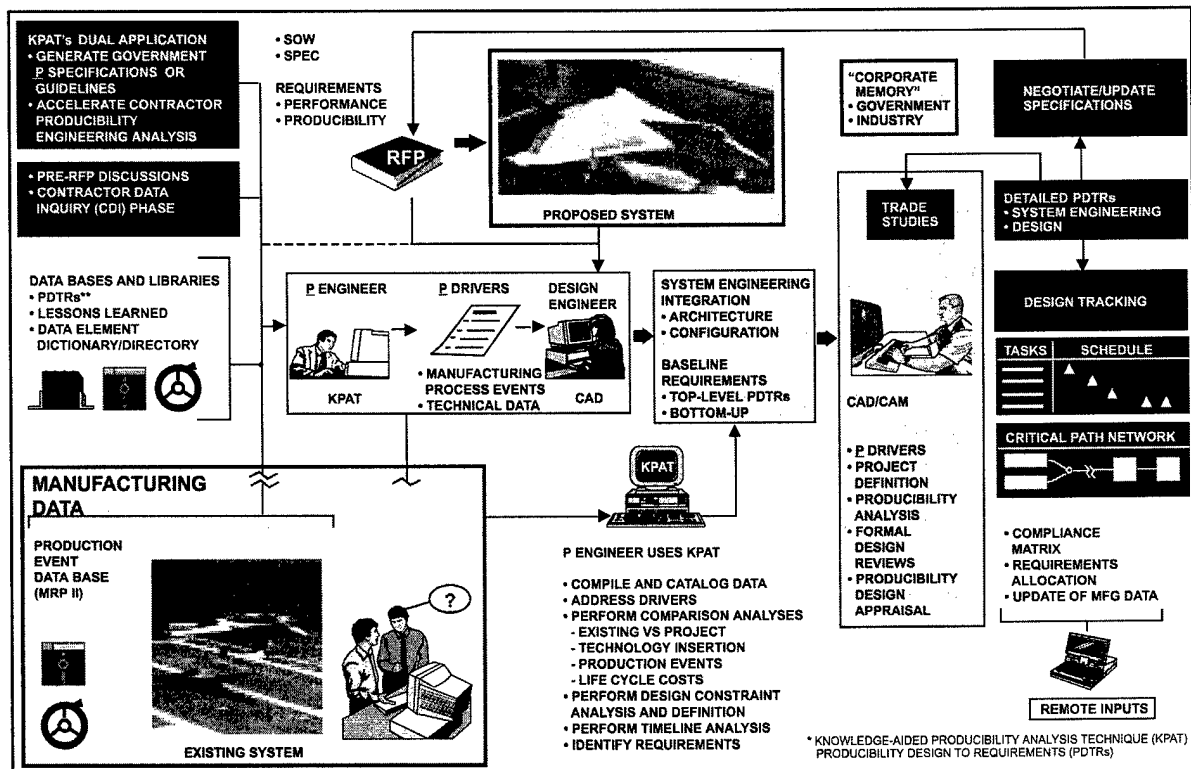

Figure E.14 - KPAT Augments Producibility Design Analysis

considerations for the PDTRs. Once the manufacturing support event criteria (f,d,c) appear to be successfully implemented, then the technology is deemed feasible for product development. During the transition to actual manufacture there will be additional opportunities for PDTR development. If the initial PDTR process was sufficiently rigorous, the manufacturing aspects of that technology should be negligible.

Producibility Engineering and the Military Depot

The military depot environment can be representative of a contractor's manufacturing facility. Although the depots typically do not fabricate entire systems as do their industrial counterparts, they do perform major structural repairs on severely damaged aircraft, or implement Engineering Change Proposals. Depots also perform complex repairs on systems and components of systems which in many cases require reverse engineering. Since these depots are similar to a manufacturing facility, consideration should be given to include military depots within producibility engineering guidelines.

Depots are currently re-evaluating their internal processes, and significant reductions in life cycle costs could occur if in the early design stages, the PDTR development were to consider depot equipment capabilities for the projected fielded systems, or those already fielded, as shown in Figure E.16. The depots could play a key role by submitting their PDTRs at the onset of a development program, thereby ensuring that their facilities could provide depot repairs at substantially reduced costs.

The KPAT could be used to benchmark the producibility characteristics of existing systems by applying available PDTRs for comparison purposes. PDTRs may also serve as guidelines during a technology insertion process to ensure that the technology does not proliferate producibility risks. A producibility/supportability synergism can be accomplished when the supportability version of KPAT is integrated with the depot producibility analyses. Factory flow optimization after PDTR implementation can help determine PDTR effectiveness even in a depot context.

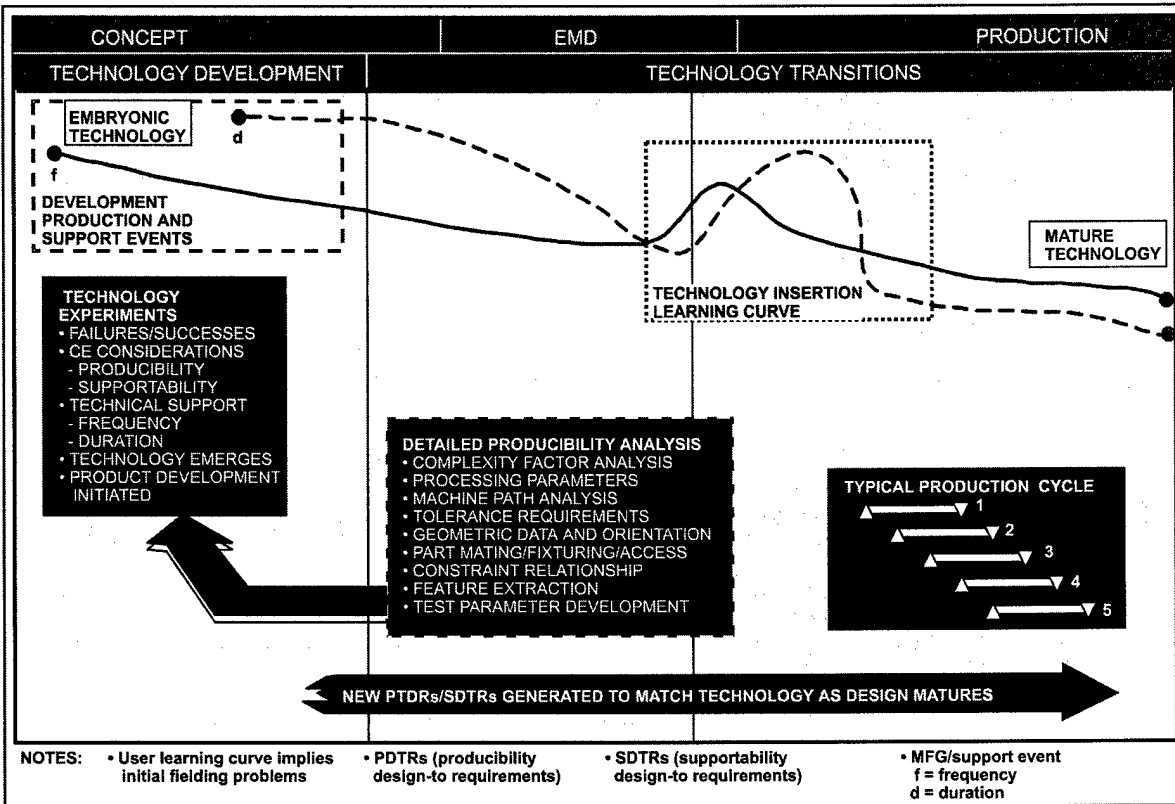

Figure E.15 - Concurrent Engineering Influence

Benefits

The benefits to producibility engineering are numerous. When a customer identifies key producibility issues which may have been based on a predecessor system, those issues can be translated into PDTRs to ensure producibility risk reduction. Competition is invigorated and risk mitigated to some extent, since the requirements represented by the PDTR can be challenging, yet risk is reduced by ultimately articulating requirements that avoid potential pitfalls.

Identifying producibility drivers and streamlining the requirements definition process can also help track a contractor's degree of IPT design involvement. Only stating that an IPT was used in the development process does not necessarily mean that discrete producibility requirements were incorporated into the design unless these and trade studies were documented. A contractor could easily be monitored by a customer to determine how effectively these PDTRs were incorporated into the design. It also helps reduce risk by minimizing "program phase transition risks." If supportability engineering is integrated early in the development phases, the program phase transition from production to support would be accomplished with less risk. And finally, military depots could take advantage of the PDTR development technique, ensuring that the depot process will be considered during the design stages. This could result in lowered depot costs for repairs or Engineering Change Proposals.

For the contractor, producibility engineering integrates with the systems engineering process and provides a critical communication link with the designer to achieve design fusion and feedback from production and support data collection systems. It promotes use of knowledge-based systems in design cycle, accelerates proposals, Engineering Change Proposals, and Service Life Extension Programs.

For design engineering personnel, producibility engineering can provide early inputs through the PDTRs to stimulate innovation and design solutions. It can also facilitate interactive functionality with the IPT during product definition, and minimize the risk associated with discovering problems during Production Design Reviews and Critical Design Reviews.

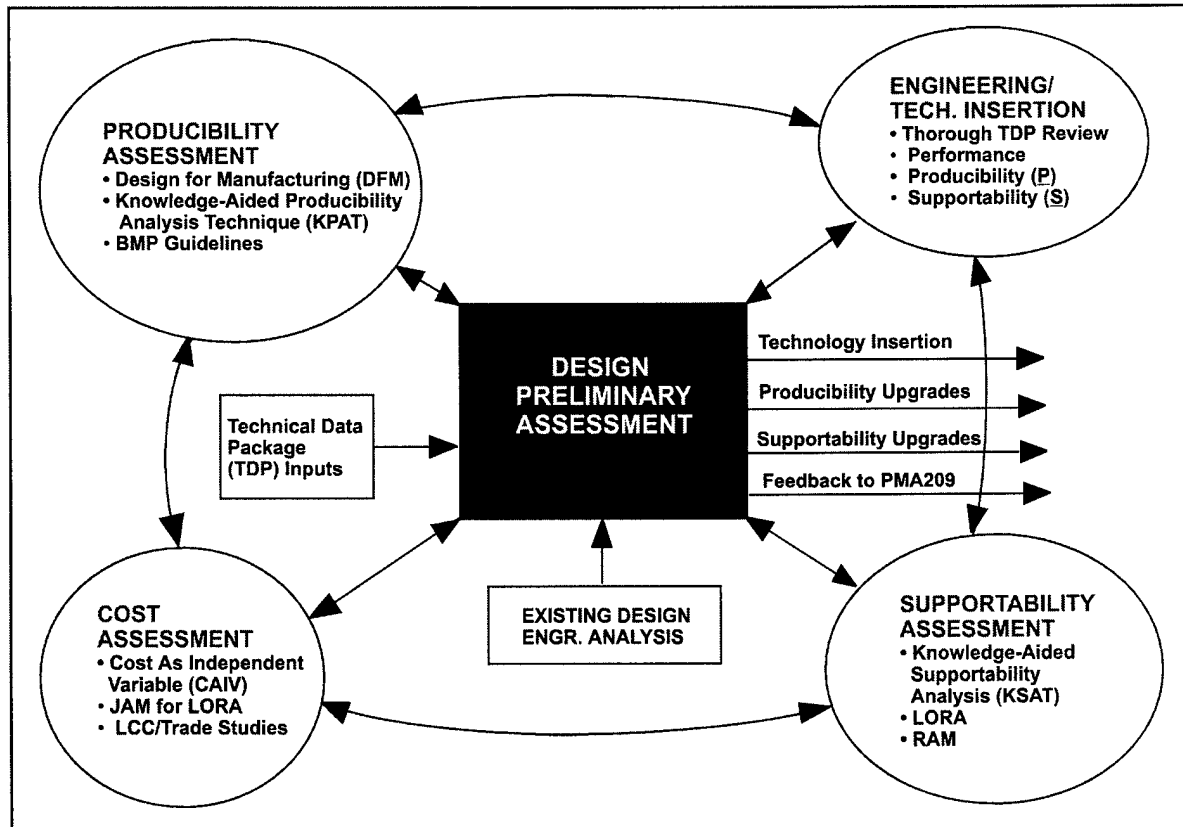

Figure E.16 - Field Systems Benefit from Producibility and Supportability Engineering Improvements

Conclusion

Declining budgets, foreign competition, rising costs, and increased design complexities prompt the IPT to offer a streamlined requirements definition. This process can impact product definition and reduce acquisition costs. When integrated with supportability efforts, a requirements definition process can also generate product supportability design-to-requirements to help achieve Total Ownership Cost goals and objectives. The results of integrating the IPT with effective knowledge-aided techniques will readily benefit both the customer and industry, and favorably affect time to market and lean enterprise endeavors.

Authors

W. Erich Hausner
TRW Avionics System Division
San Diego, California

Mr. Hausner is currently the Project Engineer - Producibility and Supportability Research for TRW Avionics Systems Division. His primary focus has been producibility and supportability research, and life cycle cost analyses for various aircraft and space programs. He integrates producibility and supportability domain experts within the systems engineering/design domain, conducts research and development in advanced producibility and supportability concepts, and defines related design requirements. Mr. Hausner's previous experience includes responsibilities as an Expediter and Tool Tracker, and he worked with methods engineers to streamline manufacturing processes.

Mr. Hausner developed the Knowledge-Aided Producibility / Supportability Analysis Technique. The International Society of Logistics awarded him the prestigious Field Award for Concurrent Engineering, and the Best Technical Paper, "Acquisition and Support."

Paul Blackwell
Department of Defense
Naval Aviation Depot - North Island
San Diego, California

Mr. Blackwell is a Supportability Engineer at the Naval Aviation Depot - North Island. He has represented the Depot by leading a research effort to enhance and apply the TRW Avionics Systems Division's Knowledge-Aided Supportability Analysis Technique. During the implementation of the Knowledge-Aided Supportability Analysis Technique, he conducted Supportability Analyses for avionics systems of the E-2C, C-2A, EA-6B, H-46, S-3B and P-3 aircraft. Mr. Blackwell's previous responsibilities include developing tactical navigation software for the Department of Defense while at the Depot.

Besides working for the Department of Defense, Mr. Blackwell held a position at TRW Vehicle Safety Systems, where he became certified as a reliability engineer through the American Society for Quality. In this position, he studied design and production test data to determine product reliability.

E.3. Producibility Program Implementation Checklist

An example of a generic product development design review flow chart and checklist are presented below. The flow chart provides insight into the sequence of reviews that typically occur during the design phase. It can be an effective tool for tracking critical design parameters and producibility progress throughout this phase. The chart can be tailored, based on the complexity of the product that is under development. For hardware that is highly complex, additional design reviews may be required for better progress tracking.

- **System Requirements Phase**
 - Clarify customer requirements
 - Identify safety and environmental design requirements
 - Develop conceptual design
 - Identify new technology
 - Establish Design-to-Cost (DTC) goals
 - Establish Six Sigma goals
 - Identify test requirements
 - Identify key suppliers
 - Identify fabrication process and capability
 - Identify risk
 - Hold Systems Requirements Review (SRR)

Entry Criteria: This phase begins when there is a signed contract, a budget has been approved, and the project has been staffed to support initial planning activities.

Exit Criteria: This phase is complete when the customer agrees that the requirements have been documented clearly, the goals and objective have been identified, and the conceptual design is complete.

- **Preliminary Design Phase**
 - Identify critical design parameters
 - Fabricate product model

-
- Develop manufacturing process plan
 - Develop product test strategy
 - Identify parts and materials
 - Perform initial Sigma analysis
 - Perform initial Design for Assembly (DFA) analysis
 - Establish Defects per Unit (DPU) goal
 - Update DTC goals
 - Perform trade studies
 - Perform preliminary producibility analysis
 - Generate design documentation
 - Hold supplier producibility reviews
 - Hold Preliminary Design Review (PDR)

Entry Criteria: The customer agrees with the design concept. All action items from the SRR are closed.

Exit Criteria: The customer agrees with the qualification plan. Preliminary analysis indicates that the product requirements, cost, and schedule can be met.

- **Critical Design Phase**

- Build engineering prototype
- Verify performance to customer requirements
- Verify parametric sigma performance
- Verify process sigma to goal
- Verify DTC to goal
- Verify DPU to goal
- Final production layout
- Release formal design documentation
- Update DFA analysis
- Update producibility analysis
- Hold supplier producibility review
- Hold Critical Design Review (CDR)

Entry Criteria: Action items from the PDR are complete. The customer agrees with the outcome of the PDR.

Exit Criteria: The engineering prototype has demonstrated functional compliance to customer requirements and manufacturing targets. Final configuration has been documented.

- **Production Readiness Phase**

- Build pilot production units
- Validate DPU, DFA analyses to goal
- Validate DTC analyses to goal
- Validate process sigma to goal
- Optimize producibility implementation
- Generate manufacturing metrics
- Verify shipping, packaging, and customer documentation

-
- Certify production process
 - Qualify product performance to customer requirements
 - Hold Production Readiness Review (PRR)

Entry Criteria: All the action items of the CDR are complete. The customer agrees with the qualification test results.

Exit Criteria: The production process has demonstrated the capability to meet producibility and product cost targets. Parametric qualification tests have been complete and are compliant with the customer requirements. The production line is certified.

- **Full Scale Production**

- Ensure continuous improvement of producibility factors
- Ensure continuous measurement of the manufacturing process
- Generate design process postmortem report
- Update lessons learned list
- Periodically verify product to customer requirements

Continuously measure the process and make improvements. Perform a postmortem to improve the product development process for future applications.

General Notes:

1. The design review process can be tailored to meet the needs of any contract and any customer. The tailoring process can be done by the IPT based on the expected output and the needs of the customer.
2. It is essential that the process is fully supported by the IPT and outside expertise who will provide a variety of views on the product development progress.
3. It is important that all the actions of a given design phase be complete prior to starting the next design phase.
4. The postmortem process is important to provide a continuous improvement action both for the product producibility process and the product development process.

A typical design review checklist, with responsible parties and their roles highlighted for each task, is shown in Figure E.17.

Author

Art Froehlich
Motorola, Satellite Communications Group
Chandler, Arizona

System Requirements Review											
No. Milestone / Tasks	Project Leader	MFG	Eng.	QA	Sales/ Mktg	Rel Eng	Mat'l	SM	Fin	Target Date	Act comp date
Develop Design Requirements Document	C	C	P	C	C	C	C	C			
Identify Critical Parameters	C	C	P	C	C	C		C			
Develop Conceptual Design	C		P			C					
DTC Cost Trade Off	C	P	C	C							
Structural Analysis			P								
Identify Fabrication Process and Capability		P		C							
Process Sigma Estimates				P							
Develop Product Test Plan	C	P	C	C							
Generate Producibility Plan	C	P	C	C	C	C		C	C		
Identify New Technology		C	P			C	C				
Identify Key Suppliers			P	C				C			
Develop Six Sigma Plan	C	C	C	P							
Generate Development Specification	C	P	C	C							
Risk Assessment	P	C	C	C	C	C	C				
System Requirements Review (SRR)	P	C	C	C	C	C	C	C			

Key: P = Primary Responsibility; C = Major Contributor; A = Review and Approve; V = Verify

Team Approval:

_____	_____
Project Leader	Engineering Team Leader
_____	_____
Manufacturing Team Leader	Materials Team Leader
_____	_____
Quality Assurance Team Leader	Purchasing
_____	_____
Marketing/Sales	Finance

Figure E.17 - Typical Design Review Checklist

Appendix F

TOOLS AND TECHNIQUES

Appendix F contains two sections, both relating to producibility tools and techniques.

Appendix F.1: Contains discussions on the tools and techniques listed in Figure I.6.

Appendix F.2: Contains a listing of available producibility software in the following categories: (1) Design for Manufacture / Assembly; (2) Statistical Process Control / Statistical Quality Control; (3) Simulation; (4) Tolerance Analysis; and (5) Miscellaneous Producibility Software.

F.1. Tools and Techniques

Appendix numbers and page numbers for the tools and techniques presented can be found in Figure F.1. In Figure F.2, the tools and techniques are shown referenced against the producibility system elements where they are used. The producibility system elements are discussed in Step 1 through Step 5 of this guidelines document.

Appendix	Tool / Technique	Page
F.1.1	Benchmarking	F-3
F.1.2	Cost Tools	F-4
F.1.3	Database Management Systems	F-5
F.1.4	Decision Support Tools	F-7
F.1.5	Design for Manufacture / Assembly (DFMA)	F-8
F.1.6	Design of Experiments (DOE)	F-9
F.1.7	Failure Mode and Effects Analysis (FMEA) ⁽¹⁾	F-10
F.1.7	- Design Failure Mode and Effects Analysis (DFMEA) ⁽¹⁾	F-10
F.1.7	- Process Failure Mode and Effects Analysis (PFMEA) ⁽¹⁾	F-10
F.1.8	Integrated Product and Process Development (IPPD)	F-12
F.1.9	Integrated Product Team (IPT)	F-13
F.1.10	Knowledge-Based Systems	F-14
F.1.11	Manufacturing Planning Tools	F-15
F.1.12	Manufacturing Simulations	F-17
F.1.13	Modeling and Simulation	F-17
F.1.14	Producibility Assessment Worksheet (PAW)	F-18
F.1.15	Prototyping	F-19
F.1.16	Quality Function Deployment (QFD)	F-21
F.1.17	Rapid Prototyping	F-23
F.1.18	Risk Management Tools	F-24
F.1.19	Root Cause Analysis (RCA)	F-25
F.1.20	Six Sigma	F-26
F.1.21	Statistical Process Control (SPC)	F-27
F.1.22	Statistical Quality Control (SQC)	F-29
F.1.23	Tolerance Analysis	F-30
<p>Note: (1) DFMEA and PFMEA are discussed in a general write-up on FMEA.</p>		

Figure F.1 - Producibility Tools and Techniques

Tool / Technique	Producibility Steps and Elements														Appendix				
	Infrastructure			Process Capab			Conceptual Design				Final Design			Measurement					
	1.1 Mgmt Commitment	1.2 Organize for Prod	1.3 Risk Mgmt Program	1.4 New Product Intro Strategy	1.5 Prod Design Guidelines	1.6 Commercial Best Practices	2.1 Current Capabilities	2.2 Future Capabilities	3.1 Product Goals	3.2 Key Characteristics	3.3 Trade Studies	3.4 Manufacturing Plan	3.5 Complexity Analysis	4.1 Prod Eng Review	4.2 Error-Proof Design	4.3 Optimize Manufacturing	5.1 Measure Processes	5.2 Measure Products	5.3 Measure Prod System
Benchmarking						X	X	X			X					X			X
Cost Tools							X		X										F.1.1
Database Management Systems					X		X	X									X		F.1.2
Decision Support Tools					X		X	X										X	F.1.3
Design for Manufacture / Assembly (DFMA)										X				X					F.1.4
Design of Experiments (DOE)							X										X		F.1.5
Failure Mode and Effects Analysis (FMEA) ⁽²⁾										X								X	F.1.6
- Design Failure Mode and Effects Analysis (DFMEA) ⁽²⁾							X							X					F.1.7
- Process Failure Mode and Effects Analysis (PFMEA) ⁽²⁾							X							X					F.1.7
Integrated Product and Process Development (IPPD) ⁽¹⁾	X																		F.1.8
Integrated Product Team (IPT) ⁽¹⁾		X																	F.1.9
Knowledge-Based Systems				X			X	X											F.1.10
Manufacturing Planning Tools											X								F.1.11
Manufacturing Simulations												X							F.1.12
Modeling and Simulation							X			X									F.1.13
Producibility Assessment Worksheet (PAW)							X			X									F.1.14
Prototyping							X			X									F.1.15
Quality Function Deployment (QFD)		X							X	X									F.1.16
Rapid Prototyping											X								F.1.17
Risk Management Tools			X																F.1.18
Root Cause Analysis (RCA)					X										X		X	X	F.1.19
Six Sigma							X										X	X	F.1.20
Statistical Process Control (SPC)							X											X	F.1.21
Statistical Quality Control (SQC)																		X	F.1.22
Tolerance Analysis																		X	F.1.23

Notes:
(1) IPPD and IPT are shown only in the sections where they are introduced. However, they are widely discussed throughout the document.
(2) DFMEA and PFMEA are discussed in a general write-up on FMEA.

Figure F.2 - Tools and Techniques vs. Producibility System

F.1.1. Benchmarking

Benchmarking is the continuous process of measuring one product or process against another similar product or process to identify best practices. It is a starting point for initiating change within a company or organization. The most common reasons an organization will benchmark are to determine where they stand amongst the competition and whether value can be added by incorporating the practices of others. Benchmarking can be used by organizations for comparison of internal operations, competitor-to-competitor products, industry standing, and generic business functions or processes. The goal of benchmarking is to identify the best practices of industry and to adapt and/or incorporate those practices that are beneficial to the organization.

In benchmarking, it is always best to start with a known problem that can be defined or one that has the potential to provide the maximum benefit to the organization. When applied to producibility, benchmarking can result in the identification of processes that will reduce cost, improve quality, and result in more desirable products for the customer.

Benchmarking within an organization can be used for the setting of goals and spurring creativity and innovation. It can also be employed to identify solutions for product or process problems. Benchmarking is an effective means of identifying improvements within an organization by raising the standard of quality and efficiency in a product or process. The standard of quality is elevated when comparison via benchmarking identifies opportunities and methods that can improve upon the item, process, or procedure being benchmarked.

When a company decides that it will strive to have the best product or process, benchmarking is used to determine its current status in the industry and to identify any steps necessary to reach its goal of becoming or remaining the best. In many cases, companies form benchmarking partnerships to permit the exchange of data. The benchmarking partner can be either a primary competitor, an internal organization, or, ideally, a world-class organization, which may be more likely to share information than a primary competitor.

There are four primary phases of benchmarking. The first phase is the planning phase during which the product or process to be benchmarked is identified and the companies to be used for comparison selected. The type of data to be gathered is identified, and the data is collected. One method to gather data is through a questionnaire to the benchmarking partner that specifically addresses the area being benchmarked.

The second phase is data analysis. In this phase, all aspects of the identified competition or benchmarking partner are analyzed to determine variations between the two similar products or processes. The information is compared for similarities and differences to identify improvement areas. This is where the current performance gap between the two benchmarking partners is determined.

The third phase, integration, is where the findings are communicated; goals are established; and a plan of action is defined.

Implementation, the fourth phase, consists of initiating the plan of action and monitoring the results. The product or process that was benchmarked continues to be monitored for improvement and should be benchmarked often to ensure the improvement is continuous.

References:

- Andersen, B., & Pettersen, P. (1996). The Benchmarking Handbook. London: Chapman & Hall.
- Bemowski, K. (1991). The Benchmarking Bandwagon. Quality Progress.
- Boxwell, R. J. (1994). Benchmarking for Competitive Advantage. New York: McGraw-Hill Companies.
- Drew, S. A. W. (1997). From Knowledge to Action: The Impact of Benchmarking on Organizational Performance. Long Range Planning, 30(3), 427-441.
- Finnigan, J. P. (1996). The Manager's Guide to Benchmarking. San Francisco: Jossey-Basser Publishers.
- Golwasser, C. (1995). Benchmarking: People Make the Process. Management Review, 84(6), 39-43.

Harrington, H. J. (1996). The Complete Benchmarking Implementation Guide. New York: McGraw-Hill Companies.

Karlof, B., & Ostblom, S. (1993). Benchmarking. Chichester, ENG: John Wiley & Sons.

Rostadas, A. (1995). Benchmarking-Theory and Practice. England: Chapman & Hall.

Spendolini, M. J. (1992). The Benchmarking Book. New York: AMACOM.

Zairi, M. (1996). Effective Benchmarking. London: Chapman & Hall.

Zangwill, W. (1994). Ten Mistakes CEOs Make About Quality. Quality Progress, 27(6), 43-48.

F.1.2. Cost Tools

In today's global economic environment, successful product development requires achieving the proper balance between cost, performance, and schedule objectives. Historically, product development, especially for defense equipment, has been performance-based, with minimal emphasis on controlling cost. Consequently, the costs associated with product development typically have increased dramatically throughout a product's life-cycle.

An extensive array of cost tools and techniques are available for assessing, managing, and controlling costs in a product development and manufacturing enterprise. In addition to accepted accounting procedures for computing the cost of sales of a product after it has been manufactured, specific techniques are aimed at determining the elements of those costs and on predicting the costs of new products prior to production. Some of these techniques include:

- **Activity-Based Costing (ABC)** which is used to assess the cost of every step in a process including all indirect overhead costs. Adding of the costs for each activity yields the cost of the product.
- **Cost As an Independent Variable (CAIV)** which treats cradle-to-grave, life-cycle cost as one of the independent variables in a design process and encourages trading it with performance and schedule.
- **Design-for-Cost (DFC)** which encourages the consideration of cost from the beginning of the design process.
- **Design-to-Cost (DTC)** which focuses on the product development and manufacturing costs, the setting of a target cost, and the achievement of that cost.
- **Parametric Cost Estimating** which consists of the analysis of models of the cost of developing and producing each of the standard components of a design.

Cost tools provide the basis for focusing attention on cost from the inception of a product development activity. Such tools vary in their difficulty of application and hence will not be used by every enterprise uniformly. The important point is to ensure that cost is addressed early in the design and development process. Achieving affordable products requires designing the products to be affordable.

From the producibility perspective, by developing and maintaining a database of cost data, new product costs can be predicted and assessed. At the beginning of the design process, costs should be estimated for each element needed to achieve each performance goal of the product and for the timely development of those elements so that the product will be available on schedule. Design tradeoffs should include the impact on cost as well as on performance and schedule. As manufacturing simulations (see Appendix F.1.12) and prototypes (see Appendix F.1.15 - Prototyping and Appendix F.1.17 - Rapid Prototyping) are developed and limited production begins, the cost estimates should be re-evaluated and modified as appropriate. Implementation is facilitated through the use of an empowered team approach (see Appendix F.1.9 - Integrated Product Team), which includes customer representation and is most effective for establishing and continuously evaluating the various objectives and making the necessary tradeoff decisions throughout the development cycle.

Cost tools and methodologies provide an effective means for integrating cost management techniques into the product development process. When successfully executed in conjunction with other producibility practices, these tools provide a means for reducing total life-cycle costs while optimizing the product development process.

References:

- Anderson, D. M. (1990). Design for Manufacturability: Optimizing Cost, Quality, and Time-to-Market. Cambria: CIM Press.
- Dean, E. B. (1992). Design for Cost: Techniques and Impact on the Cost Community. NASA Cost Estimating Symposium.
- Hoult, D. P., & Meador, C. L. (1995). Methods of Integrating Design and Cost Information to Achieve Enhanced Manufacturing Cost/Performance Trade-Offs. Management Support Technology Corporation.
- Kaplan, R. S., & Cooper, R. (1997). Cost and Effect: Using Integrated Cost Systems to Drive Profitability and Performance. Boston: Harvard Business School Press.
- Magrah, E. (1997). Integrated Product and Process Design and Development. New York: CRC Press.
- Michaels, J. V., & Wood, W. P. (1997). Design to Cost. New York: John Wiley & Sons.

F.1.3. Database Management Systems

A database management system is a computer application used to create, maintain, and provide controlled access to a database. A database is a shared collection of logically related data pertinent to an area of endeavor. A database management system is used to facilitate the collection, organization, and retrieval of data needed by the community of individuals involved in the endeavor. The system is used through the facilities of a "user interface" which provides the computer aided functions of data storage, retrieval, and modification.

In an organization's producibility efforts, the use of a database management system would pertain to a number of areas including: design guidelines, process capability guidelines, process measurement data, product measurement data, and producibility analyses data. The management and effective use of this data would be greatly facilitated through the functions of an associated database management system.

Data can be described as facts concerning objects, events, processes, or activities. Information is data that has been organized, processed, and presented in a form suitable for human interpretation and use. The steps necessary to convert data into information are acquisition, storage, manipulation, retrieval, and distribution. These steps describe the functions of a database management system.

In any endeavor, data is a primary constituent; and it exists of its own accord, with little, if any, human intervention. This data includes historical data providing the information necessary to initiate the endeavor as well as data gained as the endeavor progresses. The optimum conclusion of the endeavor is greatly influenced by the use of this data. A database management system maximizes the efficient, effective, and complete use of the data, which, in turn, maximizes the level of success of the endeavor.

As stated above, if management of data is not addressed, the data will still exist, but it will exist in a disorganized and possibly unusable state. Using a database management system ensures that data can be efficiently stored and retrieved for use when necessary. Benefits of a database management system include:

Minimal Data Redundancy: Occurrence of a data item is limited to the minimum necessary, in most cases, one. Minimal data redundancy promotes accuracy and efficiency in data storage and facilitates data consistency (see below). In a relatively few cases, duplicate occurrences of a data item are utilized for faster data access. The point is that, with a database management system, redundancy is controlled.

Consistency of Data: The elimination of data redundancy ensures data consistency. In those cases where data redundancy is allowed, a database management system enforces data consistency.

Integration of Data: In a database, data is organized into single, logically related structures. A database management system provides functions for exploiting the data relationships in retrieval and subsequent analysis.

Sharing of Data: A database management system provides for shared use of the database among multiple users.

Uniform Security, Privacy, and Integrity Controls: A database management system includes controls in the use of the database. These controls and their administration through centralized and standardized processes provide for the security, privacy, and integrity of the data.

A database management system is useful throughout the lifetime of an endeavor. In the planning stage, the database can provide information from specifications, samples, and similar successful efforts that will produce a plan that leads to a successful execution with minimum changes. In the execution stage, this same information can guide the execution through areas that may otherwise produce problems. At completion, the database management system is used in evaluating the success of the endeavor. Throughout the endeavor, a database management system collects additional data that can be used in future efforts.

A database management system includes a "user interface" that provides for the execution of those functions embedded in the operation of the database. These functions include simple storage, retrieval, and modification of data. Also, the system allows for data searches based on a partial definition of the data to be retrieved or based on the logical relationships of associated data. Most systems implement the Structured Query Language (SQL) that provides a standardized methodology for execution of database functions.

Database management systems are available from a multitude of vendors. Several representative systems are listed below:

Paradox 9: Paradox 9 is a relational database application that allows novice users to create a database with ready-to-use templates. Help features guide users through the creation of tables, forms, reports, and other database components. For more experienced users, Paradox 9 includes an object-based, event-driven development language that is used to create customized database applications. Paradox 9 operates in the Microsoft Windows environment. It is available from Corel Corporation, 1600 Carling Avenue, Ottawa, Ontario, K1Z 8R7, Canada. Telephone (613) 728-8200.

Access 2000: Microsoft Access 2000, a component of the Professional edition of Office 2000, is a widely used desktop database. It provides a broad range of tools to enter, analyze, and present data for individuals and workgroups managing megabytes of data. Microsoft Access 2000 operates in the Microsoft Windows environment. It is available from Microsoft Corporation, One Microsoft Way, Redmond, WA 98052-6399. Telephone (425) 882-8080.

Visual FoxPro 6.0: Microsoft Visual FoxPro 6.0 is the newest version of Microsoft's tool for creating high-performance database components and solutions. Visual FoxPro 6.0 gives developers the necessary tool for programming a fully developed data management application for end users. Visual FoxPro 6.0 operates in the Microsoft Windows environment and can manage a database of over 100 Gbytes. It is available from Microsoft Corporation, One Microsoft Way, Redmond, WA 98052-6399. Telephone (425) 882-8080.

References:

McFadden, F. R., & Hoffer, J. A. (1994). Modern Database Management. Cambridge, MA: Benjamin-Cummings Publishing Company.

Rob, P., & Coronel, C. (1997). Database Systems, Design, Implementation, and Management. Cambridge: Course Technology.

F.1.4. Decision Support Tools

Decision support tools permit decision makers to efficiently analyze and process large amounts of data required for decision making. Modern tools are computer based with interactive access to large database systems and allow for extracting, analyzing and presenting information from the databases in a useful format (see Appendix F.1.3. - Database Management Systems). Decision support tools are used as an aid to the decision makers by extending their intuitive capabilities; the tools are not meant to replace the decision-makers' judgement or expertise.

With regard to producibility efforts, decision support tools can facilitate the acquisition of pertinent information from producibility databases. Although they can be employed in many of the steps to producibility, they are perhaps most useful in assessing process capabilities to address specific manufacturing needs. Processing and assembly information that has been entered into relational and other databases during the manufacture of various products can be of great use in assessing the ability to manufacture new products. However, if the databases contain a lot of information, it becomes economically difficult to sort through the information and identify all information needed. A decision support tool can assist in the effort.

There are three basic types of decision support tools: (1) query and reporting; (2) on-line analytical processing; and (3) enterprise reporting. Query and reporting is an outgrowth of managing relational databases. It resulted from the need to sort large amounts of data. On-line analytical processing is an outgrowth of the management need for simple, high-level, graphical views of enterprise-level data. Typically, these tools provide instant red-flags for "out-of-spec" results. They allow the user to access detailed data from the top down but do not have query and reporting capabilities. Enterprise-reporting tools are an attempt to provide a single tool for the entire enterprise. They provide electronic reporting of data in the form of pre-defined reports that satisfy a wide range of corporate needs but do not provide for new queries or for the analysis and reporting of data other than in the pre-defined reports. The next generation of decision support tools are analytical reporting tools which include the ability to conduct interactive analysis on a report, thereby allowing new searches to be initiated, new reports to be formatted, and new as well as old data to be analyzed as the user desires.

It should be noted that not all decision support tools will work on all databases, nor are all the tools capable of all types of data retrieval and analysis. Vendors of decision support tools can provide information on what their tools can accomplish and on what databases they can be utilized. They can also provide instruction in the application of the tools. Consultants are available to both advise on the applicable tools and conduct any required data searches and analyses.

References:

Business Objects of America. 2870 Zanker Road, San Jose, CA 95134. Telephone (408) 953-6000, (800) 527-0580, Fax (408) 953-6001.

Parasei, H. R., & Kolli, S. (1995). Manufacturing Decision Support Systems. Chapman & Hall.

Stahre, J., & Johansson, A. (1994). Decision Support for Flexible Manufacturing. Fourth International Conference on Human Aspects of Advanced Manufacturing and Hybrid Automation. Manchester: IOS Press.

Stahre, J., & Johansson, A. (1994). Albert - A Decision Support Tool for Operators in Manufacturing Systems. Fourth International Conference on Human Aspects of Advanced Manufacturing and Hybrid Automtion. Manchester: IOS Press.

F.1.5. Design for Manufacture / Assembly

Product designs are often developed with little consideration of manufacturing and assembly requirements. Typically, design deficiencies are not identified until a product is in the manufacturing stage of the development process. Major design changes are often required to complete production, which results in schedule delays and increased development costs. Companies have begun using the Design for Manufacture/Assembly (DFMA) technique as a tool to optimize the product development process and alleviate this problem.

The DFMA concept emphasizes obtaining the proper balance between design objectives, manufacturing and assembly requirements, and process capabilities to decrease product development cycles and costs. Because more than half of the total cost associated with product development can be attributed to design decisions made early in the development process, a key component of DFMA is to integrate the development of manufacturing and assembly requirements into the design phase. To meet this objective, this technique facilitates having the design and manufacturing teams working together (see Appendix F.1.9 - Integrated Product Team) to define design goals. Therefore, any problems related to manufacturing and assembly can be detected early, and the design can be corrected before being finalized. Also, the need for any new manufacturing or assembly processes can be identified early, and, if necessary, process maturity efforts can be incorporated into the overall schedule, thereby avoiding unnecessary delays to production. Use of this technique throughout the product development cycle results in less complex, higher quality parts that can be produced at a lower cost.

The primary objective of DFMA is to simplify product design, which, in turn, simplifies the manufacturing and assembly processes required for production. Following are examples of the DFMA guidelines that can be used to simplify product design:

- Minimize the number of parts necessary to provide the required level of performance and model variations.
- Give careful consideration to existing process capabilities and avoid unnecessary processing requirements when developing designs. Developing a new process can substantially increase overall product development costs and schedule.
- Design parts so that assembly is straightforward and manual intervention is only value-added.
- Minimize the use of flexible parts such as belts, gaskets, and cables. The flexibility of these types of components makes handling and assembly more difficult and increases the part's susceptibility to damage.
- Minimize the use of threaded fasteners, which are time consuming to assemble and difficult to automate. The use of snap-together-fit and other joining techniques improves the efficiency of manufacturing, assembly, and disassembly.
- Incorporate modularity into product design. Modularity reduces the number of parts required and improves the overall quality of the final product.
- Consider automated production of parts.

The DFMA technique optimizes product development by providing a formal process for simultaneously defining and analyzing design goals along with manufacturing and assembly requirements. Integrating these functions results in a product design that can be efficiently manufactured and assembled to produce a product that meets the customer's needs. Other benefits to be gained from implementing this technique include reduced production time, improved product quality, and a lower total life-cycle cost.

References:

- Boothroyd, G., Dewhurst, P., & Knight, W. (1994). Product Design for Manufacture and Assembly. New York: Marcel Dekker.
- Bralla, J. G. (1998). Design for Manufacturability Handbook. New York: McGraw-Hill Companies.
- Lotter, B. (1989). Manufacturing Assembly Handbook. Woburn, MA: Butterworth-Heinemann.

Magrah, E. (1997). Integrated Product and Process Design and Development: The Product Realization Process. New York: CRC Press.

Redford, A., & Chal, J. (1995). Design for Assembly: Principles and Practice. New York: McGraw-Hill Companies.

DRM Associates. The Product Development Forum. 2613 Via Olivera, Palos Verdes, CA 90274. Telephone (310) 377-5569, Fax (310) 377-1315, E-mail kcrow@aol.com.

F.1.6. Design of Experiments

Design of Experiments (DOE) is a technique that is used to optimize the process of conducting experiments by determining what effect adjusting various input variables will have on the outcome of a process or system. Through the use of statistics, DOE can identify the input variables that have the greatest impact on product quality and performance. By maximizing the amount of information obtained from each iteration of testing and analysis (experimentation), DOE reduces the amount of time and resources required to determine the design and manufacturing processes that will ensure production of a high quality product. Adapting DOE methodology to the production environment is commonly referred to as the Taguchi Method. When properly applied, DOE identifies the optimum setting for manufacturing processes, thereby improving the quality of the final product while simultaneously reducing product development costs.

Typically, product design is conducted in two major steps – system design and tolerance design. Using an iterative design-and-test approach, the traditional process begins with the development and testing of all components and related processes. Once the initial design phase is complete, acceptable limits for product and process variation are then determined. To streamline the design process, DOE/Taguchi Methods introduce an intermediate step, called parameter design, that uses statistical tools, such as linear and orthogonal arrays, to identify those factors that may adversely affect the design and manufacturing process. Identifying and then controlling only these factors optimizes the manufacturing process and keeps product and process variation to a minimum. Also, the amount of time spent in the design phase is shortened, which reduces design costs.

In the application of this technique, input variables are classified as either controlled factors or noise factors. Controlled factors are those variables over which the product developer has some control, such as the selection of the manufacturing processes and material used for production. Noise factors are uncontrollable variables or those over which the developer has minimal control, such as the quality of the parts and material received from a supplier. DOE can be used to identify those controllable and noise factors that have the greatest impact on product performance and quality. This technique can also be used to determine the optimum specification and tolerance values for each of these factors in order to minimize their influence on product and process performance.

DOE is often an integral part of a total quality approach to manufacturing and can be used to identify solutions to quality problems in production. The adjustments required to alleviate the problem can be identified with minimal testing and evaluation, thereby reducing the number of parts produced that do not meet specifications and therefore have to be rejected and/or reworked.

Through application of this technique, it is possible to determine the influence of the individual factors on the overall performance of the process or product being developed. DOE can be applied to producibility as a means of more completely understanding a manufacturing process and its effects on a product. It can help to identify and optimize critical process parameters, assess the effects of processing alternatives on a product, and assist in the solution of any manufacturing problems related to quality. Successful application of this technique to product development, particularly design and manufacturing, improves the consistency of product performance, which improves product quality. DOE also minimizes the costs associated with product development through optimization of the design and manufacturing processes.

References:

Anderson, V. L., & McLean, R. A. (1974). Design of Experiments: A Realistic Approach. New York: Marcel Dekker.

-
- Fowlkes, W. Y., & Creveling, C.M. (1995). Engineering Methods for Robust Product Design: Using Taguchi Methods in Technology and Product Development. Reading, MA: Addison Wesley Longman.
- Hicks, C. R. (1982). Fundamental Concepts in the Design of Experiments (3rd ed.). New York: Saunders College Publishing.
- Montgomery, D. C. (1991). Design and Analysis of Experiments (3rd ed.). New York: John Wiley & Sons.
- Peace, G. S. (1993). Taguchi Methods: A Hands-On Approach. Reading, MA: Addison Wesley Longman.
- Pukelsheim, F. (1993). Optimal Design of Experiments. New York: John Wiley & Sons.
- Taguchi, G. (1986). Introduction to Quality Engineering: Designing Quality into Products and Processes. New York: Quality Resources.
- Taguchi, G. (1987). System of Experimental Design: Engineering Methods to Optimize Quality and Minimize Costs. New York: Quality Resources.
- Taguchi, G., & Yokoyama, Y. (1994). Taguchi Methods: Design of Experiments. Dearborn, MI: ASI Press.

F.1.7. Failure Mode and Effects Analysis

Includes: Design Failure Mode and Effects Analysis (DFMEA)
 Process Failure Mode and Effects Analysis (PFMEA)

Failure Mode and Effects Analysis (FMEA) is a structured methodology for identifying failures, errors, and defects before they occur and prioritizing them for corrective action. Throughout this guidelines document, the applicability of two types of FMEA have been discussed. These are Design Failure Mode and Effects Analysis (DFMEA) and Process Failure Mode and Effects Analysis (PFMEA). DFMEA is a means of analyzing the part design for potential failures, errors, and defects prior to the first production run. PFMEA helps to analyze the part's manufacturing processes prior to production to identify possible process failures that can induce defects into the part. In both methodologies, the goal is the same – early identification of and reduction or, ideally, elimination of failure mechanisms.

FMEA is a bottoms-up approach to failure identification. It should begin with the lowest level of detail and continue until the entire system has been analyzed. From a product standpoint, lowest level parts are first analyzed, followed by components, assemblies, subsystems, and, finally, systems. It is only through this thorough analysis of the whole system, part by part, that FMEA is most effective.

FMEA, whether DFMEA or PFMEA, should be an iterative process and should be used throughout the integrated product and process development cycle. Design FMEA or DFMEA should first be performed during conceptual design and then periodically as the design matures. Information from subsequent DFMEAs helps to further refine the design to ensure that failure mechanisms have been eliminated or controlled to the greatest extent possible prior to production of the product. Process FMEAs or PFMEAs can first be performed to more thoroughly understand a process capability and, as the design matures for a particular product, to analyze the effects of the process on that particular product. Additionally, both DFMEA and PFMEA can be used once failures have occurred in production to identify problems and aid in determining corrective action. As applied to producibility, FMEA should be utilized as a basis for continuous improvement.

To illustrate the concept of FMEA and how one is performed, an example DFMEA is provided in Figure F.3. A PFMEA, however, is similar and works in the same way. The first step is to identify, by a unique identifier, each part or component in the system, starting with the lowest level detail (A). The functions that each part performs and one or two failure modes for each function are listed in (B) and (C) respectively. The effects that each failure mode would have (especially as observed by the customer) (D) and the causes of the failure (E) are then detailed. A risk assessment, taking into account the severity of the failure (F), the frequency of occurrence

(G), and the ease of failure detection (H), is performed by assessing each on a pre-determined scale (often 1 to 10). These ratings for severity, occurrence, and detection are then multiplied together to get a Risk Priority Number (RPN), which identifies the level of risk for each part (I). Pareto analysis of the RPNs can then determine which parts or failure modes are most important to concentrate on first. The relative rankings of severity, occurrence, and detection identify what should be targeted for improvement to provide the biggest payoff. The corrective or preventative action that should be taken to eliminate or reduce the failure is listed in (J) and the responsible party and the date when the action should be accomplished by in (K) and (L) respectively. After the corrective action is accomplished, the risk assessment is performed once more (M-P) to ensure that the corrective action did, in fact, reduce the risk of failure.

From a producibility standpoint, the key to successful use of FMEA is to perform it throughout the integrated product and process design cycle – as the design matures and is finalized and as the processes are locked in for production of the product. It is important to perform FMEA (both DFMEA and PFMEA) with each major change in design to ensure that new failure modes have not been introduced during design refinement as well as after a part is in production to identify any failure modes that were overlooked prior to design release.

References:

McDermott, R. E. (1996). The Basics of FMEA. Resource Engineering.

Stamatis, D. H. (1995). Failure Mode and Effect Analysis: FMEA from Theory to Execution. Milwaukee, WI: American Society of Quality Control.

Palady, P. (1995). Failure Modes and Effects Analysis. PT Publications, Incorporated.

Palady, P. (1999). FMEA: The Author's Edition - Exclusive New Developments Approved for the Federal Standard. Practical Applications.

Resource Engineering, Inc. Staff. (1998). FMEA Investigator Workbook. Resource Engineering.

Rochester Institute of Technology. (1997). Failure Mode and Effects Analysis. Rochester, NY: Rochester Institute of Technology.

Ref Drawing #: _____		IPT: _____		FMEA Dates: _____	
Component: _____		Design Responsibility: _____		Original: _____	
Subsystem: _____				Rev: _____	
System: _____					
(A)	Part	(E)	Cause of Failure	(M)	Severity
(B)	Function (of part)	(D)	Effect of Failure	(N)	Occurrence
(C)	Failure Mode	(E)	Cause of Failure	(O)	Detection
(F)	Severity	(J)	Corrective / Preventative Action	(K)	Responsibility
(G)	Occurrence	(L)	Date	(M)	Severity
(H)	Detection	(P)	RPN	(N)	Occurrence
(I)	RPN	(P)	RPN	(O)	Detection

Figure F.3 - Example DFMEA

F.1.8. Integrated Product and Process Development

As a means of improving producibility and maintaining global competitiveness, world-class companies have begun using integrated design and development concepts to improve their manufacturing processes. Integrated Product and Process Development (IPPD) emerged from earlier integrated design practices, such as concurrent engineering. IPPD, also referred to as integrated product development, expands upon this concept by involving appropriate, multi-disciplinary teams in all phases of a product's development life-cycle. IPPD activities primarily focus on meeting the customer's needs, while simultaneously reducing costs, decreasing development times, and improving product performance and quality.

For most organizations involved with product development, IPPD is a new way of doing business. Typically, product development begins with loosely defined requirements, which, in most cases, have to be changed in the latter phases of the development process, resulting in elevated development costs. There is usually minimal communication and exchange of information between the key disciplines involved in the development process, such as engineering, design, and manufacturing personnel. This lack of communication often results in the need to make costly design changes during the latter stages of the development process, which contributes to high product development costs. By fostering a disciplined, simultaneous development of products and related process capabilities, the IPPD approach aims to eliminate these and other ineffective management practices. When using IPPD, an early, thorough evaluation of cost, schedule, and performance objectives, design alternatives, and related process capabilities is critical for success. Additionally, during the early stages of the development process, process capabilities must be evaluated for every phase of the product's life-cycle.

Implementation of IPPD practices usually requires an enterprise-wide cultural change. At the core of the process is the multi-disciplinary team approach. This multi-disciplinary team is referred to as an Integrated Product Team (IPT) (see Appendix F.1.9). IPTs facilitate effective and timely communication and decision making. These teams include representatives from all essential product development activities, including engineering, design, manufacturing, and management, as well as the customer's and suppliers' organizations. One primary objective of IPPD is to correctly define the customer's requirements early in the product development process, thereby eliminating the need for costly changes to requirements during the latter stages of the process. Customer representation as part of the IPPD process is essential for meeting this objective.

Another benefit of this approach is the ability to evaluate and improve supplier performance. Often schedules are adversely affected by a supplier's inability to provide necessary parts and/or services when required. By including supplier representation in the IPPD process, realistic objectives are determined at the beginning stages of development, schedule conflicts are easily identified, and corrective action can be taken to minimize their effect.

There are no standard procedures for implementing IPPD practices within an organization. Instead, the principles, tools, and methodologies should be selected and tailored to suit the specifics of the organization's products and related processes. In addition to those identified above, IPPD principles and practices include:

- Thorough planning for product development, including identifying required processes as well as evaluating process capabilities and available technology throughout the product's life-cycle.
- Defining requirements to facilitate the use of IPPD tools and practices.
- Employing risk management (see Appendix F.1.18) activities throughout the product development process.
- Providing teams with the proper tools, resources, and authority necessary to perform their respective tasks.

Successful implementation of IPPD enables enterprises to optimize their product development processes, thereby reducing costs and development cycle times while improving product performance and the quality of both products and processes.

References:

- Clark, K. B., & Fujimoto, T. (1991). Product Development Performance: Strategy, Organization, and Management in the World Auto Industry. Boston, MA: Harvard Business School Press.

-
- Clausing, D. (1991). Flexible Product Development. Time Based Competition: Speeding New Product Design and Development Conference. Nashville, TN.
- Dacey, W. E., Norman, R. F., & Lemon, J. R. (1990). Quality Function Deployment (QFD) in Support of Concurrent Product/Process Development (CP/PD). International TechneGroup, Incorporated.
- Hollins, B., & Pugh, S. (1990). Successful Product Design: What to Do and When. London, ENG: Butterworths.
- Knill, B. (Ed.). (1985, July). Allen-Bradley Puts Its Automation Where Its Market Is. Materials Handling Engineering, 40 (7), 62-66.
- Pugh, S. (1991). Total Design: Integrated Methods for Successful Product Engineering. Wokingham, ENG: Addison-Wesley Publishing Company.
- Shunk, D. L. (1992). Integrated Process Design and Development. Homewood, IL: Business One Irwin.
- Trygg, L. (1991). Engineering Design - Some Aspects of Product Development Efficiency (Dissertation, Department of Industrial Management and Economics, Chalmers University of Technology, Göteborg, Sweden, 1991).
- Wheelwright, S. C., & Clark, K. B. (1992). Revolutionizing Product Development: Quantum Leaps in Speed, Efficiency, and Quality. New York: The Free Press.

F.1.9. Integrated Product Team

The foundation of Integrated Product and Process Development (IPPD) is the Integrated Product Team (IPT). The IPT is a multi-disciplinary teamwork approach to implement IPPD. The team is formed for the purpose of delivering a product or process to either an internal or external customer. An IPT consists of representatives from the various functional disciplines influencing the product or process. The IPT approach differs that of traditional program organizations that usually focus on single-function disciplines.

IPT members work together to design and produce a successful and balanced product – to make sound and timely decisions and to identify and resolve issues. In addition to developing a product and its associated processes, IPTs plan, track, and manage their own work and the processes by which they do their work. The focus within the team is not on individual team members' areas of specialty, but instead is on the integrated product and process development that the team has been formed to conduct.

The IPT should include members of all areas involved in the delivery of a product for an external or internal customer. Representation within the IPT may include areas such as research, development, design, testing, manufacturing, training, product service and support, finance, customers, suppliers, and contracts. All functional disciplines that influence the product throughout its lifetime should be represented. Early involvement of all key participants ensures a higher quality integrated product development by providing a more detailed understanding of all the requirements and a consensus approach to designing the product or process.

Once the team's scope and objectives have been defined, team members are assigned roles and responsibilities within the IPT. Team members should feel free to participate and make decisions. Ideally, the IPT should be kept relatively small, between seven and ten people. Larger projects can employ a leadership IPT and a number of sub-IPTs, which also should be limited in size. Leaders of sub-IPTs are members of the leadership IPT and are empowered to address key decisions under their area of control.

The role of the team leader is not a dictatorial role, but instead the IPT leader functions as a facilitator to the team to ensure that everyone's voice is heard and that no person or group dominates the team. IPT leadership should create an environment of trust and open communication. Motivation is key to keeping the momentum and focus of the group to ensure that discussions and decisions lead toward successful product development.

The IPT leader is responsible for ensuring resolution of problems and intervening when necessary to resolve issues.

Teams focus on achieving set goals and objectives by setting metrics by which to measure their progress. Defining and using metrics allows for continuous monitoring and management of the product development cycle and enables early feedback to identify possible problem areas and determine proper corrective action.

References:

- Clark, K. B., & Fujimoto, T. (1991). Product Development Performance: Strategy, Organization, and Management in the World Auto Industry. Boston, MA: Harvard Business School Press.
- Clausing, D. (1991, May 16-17). Flexible Product Development. Time Based Competition: Speeding New Product Design and Development Conference. Nashville, TN.
- Dacey, W. E., Norman, R. F., & Lemon, J. R. (1990). Quality Function Deployment (QFD) in Support of Concurrent Product/Process Development (CP/PD). International TechneGroup, Incorporated.
- Hollins, B., & Pugh, S. (1990). Successful Product Design: What to Do and When. London, ENG: Butterworths.
- Knill, B. (Ed.). (1985). Allen-Bradley Puts Its Automation Where Its Market Is. Materials Handling Engineering, 40 (7), 62-66.
- Pugh, S. (1991). Total Design: Integrated Methods for Successful Product Engineering. Wokingham, ENG: Addison-Wesley Publishing Company.
- Shunk, D. L. (1992). Integrated Process Design and Development. Homewood, IL: Business One Irwin.
- Trygg, L. (1991). Engineering Design - Some Aspects of Product Development Efficiency. (Dissertation, Department of Industrial Management and Economics, Chalmers University of Technology, Göteborg, Sweden, 1991).
- Wheelwright, S. C., & Clark, K. B. (1992). Revolutionizing Product Development: Quantum Leaps in Speed, Efficiency, and Quality. New York: The Free Press.

F.1.10. Knowledge-Based Systems

Knowledge-based systems are computer-based programs that incorporate human expertise and other documented knowledge with the facilities for applying that knowledge to real-world circumstances. Knowledge-based systems provide the benefit of and satisfy the requirement for documenting, developing, and disseminating rules, processes, and/or guidance related to a specific domain or problem area. Knowledge-based systems may be automated in embedded systems or employed through a "user interface" where questions can be presented in a manner similar to how they would be asked of a human consultant or expert.

Knowledge-based systems, sometimes called "expert systems," are made up of two major components: the knowledge base and the inference engine. The knowledge base is the repository of the knowledge, which, in some systems, is expressed as a collection of facts together with related "if, then" rules. The inference engine interprets and manipulates the combined facts and rules in the knowledge base to arrive at the answer to a question. Other components of a knowledge-based system include a knowledge acquisition subsystem and a user interface. The knowledge acquisition subsystem facilitates generation of the knowledge base. This process involves collecting information from various sources including the human "experts" and translating this information into facts and rules in the language of the knowledge base. This process has been referred to as "knowledge engineering." The user interface provides a mechanism for the effective exchange of problem-related information between the end-user and the computer system.

To a large degree, knowledge-based systems are used to extend and apply the expertise or documented knowledge of an acquired discipline to areas where it would not be efficient, practical, or even possible using a non-automated process. They are widely used by decision makers for strategic planning and for identifying areas for improving productivity and process quality. A knowledge-based system may also be used in applications associated with automatic control or process monitoring. Systems used as expert assistants are queried on an ad hoc basis whenever the knowledge of an expert is required for satisfactory execution.

The decision to employ a knowledge-based system starts with selection of the system itself. In some cases, it may be possible to acquire a commercial-off-the-shelf system that is task-specific or solution-specific to the target application. This approach might be common in applications involving financial planning and medical diagnosis, where an initial knowledge base exists. However, for applications related to leading edge manufacturing, it is more likely that the system would need to be tailored to meet the peculiarities and anomalies of the related processes. In this case, a knowledge-based system shell would be used. This shell is a software development environment containing generic system components for building the application specific system. With the shell's knowledge acquisition subsystem, the knowledge base and the inference engine are configured and instantiated using the collection of knowledge and reasoning provided from representative experts and other available facts pertinent to the processes.

A knowledge-based system can be used by an organization to acquire, document, develop, and disseminate enterprise-wide design guidelines and process capabilities. Using a knowledge acquisition system, expert knowledge and opinions as well as lessons learned related to design practices and processes can be captured to formulate the knowledge base. Engineers and designers can then access the knowledge-based system when necessary to obtain design guidelines and other information related to specific tasks at hand. Managers may access the knowledge-based system to obtain information on current process capabilities or to identify opportunities for process improvement. A key benefit of employing knowledge-based systems is that consistency of the information provided reduces error rates and improves the overall quality of an organization's designs and processes.

References:

- Durkin, J., & Durkin, J. (1994). Expert Systems: Design and Development. MacMillan Collegiate Division.
- Gonzalez, A. J., & Dankel, D. D. (1993). The Engineering of Knowledge-Based Systems: Theory and Practice. Englewood Cliffs, NJ: Prentice-Hall, Inc.
- Jackson, P. (1999). Introduction to Expert Systems (International Computer Science Series). Addison Wesley Publishing Company.
- Turban, E., & Aronson, J. E. (1998). Decision Support Systems and Intelligent Systems. Prentice-Hall, Inc.

F.1.11. Manufacturing Planning Tools

Planning of manufacturing includes the planning of purchasing, receiving, cost estimating, forecasting, and labor requirements in accordance with the production schedule. It also includes planning for the production capacity to meet the required schedule.

Within the IPPD approach to integrated product development, manufacturing planning begins during the preliminary design phase with a twofold purpose. First, as design tradeoffs are made, early manufacturing planning can assist in identifying the design concepts that can most readily and economically meet the desired production schedule. Secondly, as the design matures, manufacturing planning can assist in identifying long-lead production needs and material requirements.

Manufacturing planning tools range from very simple spreadsheets to more sophisticated tools such as Material Requirements Planning (MRP), Manufacturing Resource Planning (MRP II), and Enterprise Resource Planning (ERP). Depending on their scope and complexity, such tools can provide assistance in planning anything from the requirements to support the workload of a portion of a manufacturing cell in a production facility to planning the resource requirements of the entire enterprise. Spreadsheet approaches can be developed

in-house or purchased as packages from a number of vendors. MRP, MRP II, and ERP are more sophisticated tools for which brief descriptions are presented in the following paragraphs.

MRP is used to determine the material requirements based on the production schedule and the specific bills of materials for the products. This technique is focused on the planning of materials needed to support production based on production quantities. It was developed as an approach to assist in the management of production and a method for determining appropriate inventory levels and controlling that inventory. MRP can be used to develop plans for ordering parts and material based on a company's current production requirements and for developing the forecasted demand for a product under development. By using MRP to determine and maintain inventory levels necessary to meet the current demand for a product, insufficient or surplus inventory levels can be avoided and reduced costs can be achieved.

MRP II is an extension of MRP that combines inventory control with production control. It provides a tool for manufacturing planning that begins to tie together many of the elements of the entire enterprise. However, unlike ERP which is described below, MRP II is not one integrated planning system for the enterprise. Rather, it is focused on manufacturing and requires that all the business planning of the enterprise be based on the same production forecasts. MRP II addresses the material, physical and labor requirements to support the production schedule. It expands upon MRP by integrating other business functions within a company, including sales, marketing, financial planning, engineering and purchasing, with the manufacturing planning process. Use of this tool ensures that all business units involved in the manufacturing process are kept abreast of current production requirements, purchase plans, and customer demand. MRP II can also include simulation tools that provide the capability to conduct "what if" scenarios related to manufacturing planning. The information output from MRP II systems may be combined with other financial planning tools within an organization for decision-making and strategic planning purposes.

ERP encompasses all the planning of the enterprise associated with a product, a series of products, or all products. In addition to those items covered in MRP II, ERP extends planning to all the other areas of the enterprise. This tool provides the capability to connect all business units within a company to a single computer system as a means of improving the communication and exchange of information. As companies become more global and decentralized, the need exists to develop individual manufacturing plans for multiple sites. ERP provides a means for distribution resource planning, which means determining when and at what location within the enterprise inventory levels should be increased or put on-hold due to changes in demand. This information can then be instantly communicated throughout the company. ERP accomplishes these objectives by providing a single tool that integrates all functions and resources within a company to merge business planning activities and objectives with its operational and manufacturing processes.

Manufacturing planning tools such as these can be used to improve the manufacturing planning process and overall strategic planning within an organization. Some of the benefits to be gained from adopting such tools and techniques include reduced costs, improved responsiveness to customers' needs and to market changes, and an improved product development process.

References:

- Boothe, R.S., Haynes, P. J., & Helms, M. M. (1991, Autumn). Rethinking the Manufacturing Focus: An Overlooked Strategic Tool. SAM Advanced Management Journal.
- Brooks, R. B. (1987). Integrating JIT and MRP II. International American Production and Inventory Control Society (APICS) Conference.
- Forger, G. (1997, March). Take Control of Your Shop Floor with Manufacturing Execution Systems. Modern Materials Handling.
- Giebels, M. M. T., Kals, H. J. J., & Zijm, W. H. M. (1998). Concurrent Manufacturing Planning and Control. Manufacturing Systems. Ljubljana: Faculty Press International.

Kessler, J. (1991, March). MRP II: In the Midst of a Continuing Evolution. Industrial Engineering.

Orlicky, J. (1975). Material Requirements Planning. New York: McGraw-Hill.

Smith, J. J. (1994). Theory of Constraints and MRP II: From Theory to Results. Illinois: Bradley University.

F.1.12. Manufacturing Simulations

A manufacturing simulation is the mathematical modeling, usually coupled with a graphical representation, of a new or existing manufacturing operation. All the steps involved in the manufacture of a product are modeled and sequenced accordingly, affording the designer the opportunity to visualize each step in the process and their interrelations, prior to the start-up or independent of the operating manufacturing line. The simulation predicts or echoes the behavior of real-world systems as the products step through the manufacturing processes.

“What-if” analysis leads to optimizing the manufacturing system, which results in minimized scrap, reduced downtime, reduced queuing or bottleneck problems, and the elimination of redundant operations. Thus, the equipment, work flow, and overall manufacturing processes can then be implemented with high confidence, having been previously optimized in a virtual environment.

After the manufacturing operation is implemented on the factory floor, the simulation model provides a baseline against which any proposed changes to the system can be analyzed prior to actual implementation. Simulation is also an effective method for studying schedule optimization, throughput increase, inventory reduction, resource utilization, and problem solving.

Since simulation-based “what-if” analyses can be done off-line to troubleshoot and improve factory operations, manufacturing simulation is also an efficient testing tool. Without contributing to factory down-time, engineers can test control strategies and determine the factory response to standard operations or to transient events that may otherwise lead to an unnecessary plant shutdown.

The implementation of simulation tools can also be used to help enhance employee performance. Integrating simulation-based training for factory or plant operations personnel puts operators’ skills to work more effectively and economically. Additionally, factories with hazardous materials environments frequently build simulated “malfunctions” into their simulation-based training systems in order to train operators in emergency operation procedures.

References:

Miller, R.K., & Press, F. (1989). Manufacturing Simulation. New York: Prentice-Hall.

Harrell, C., & Tumay, K. (1997). Simulation Made Easy: A Manager’s Guide. Engineering and Management Press.

Thomson, N. (1985). Simulation in Manufacturing. New York: Wiley & Sons.

Aspire Systems. 28550 S.W. Ashland Drive, Suite 64, Wilsonville, OR 97070. Telephone (503) 570-1003.

Fluor Daniel Applied Computer Solutions. One Fluor Daniel Drive, Aliso Viejo, CA 92698. Telephone (949) 349-4546.

Imagine That, Inc. 6830 Via Del Oro, Suite 230, San Jose, CA 95119. Telephone (408) 365-0305.

Simulation Dynamics, Inc. 416 High Street, Maryville, TN 37804-5836. Telephone (423) 982-7046.

F.1.13. Modeling and Simulation

Modeling and simulation tools and techniques are being used more frequently by enterprises to improve their product development processes. To meet consumer demands, organizations are striving to produce higher

quality products while simultaneously reducing development costs and cycle times. Modeling and simulation can be used to enhance various product development and process improvement tasks, such as developing and evaluating design alternatives and manufacturing requirements as well as prototyping (see Appendix F.1.15). A model is a snapshot representation of the behavior of a process or product. Simulation involves constructing a model and conducting experiments, such as “what if” analyses, to determine the behavior of a process or product with respect to time or other factors, such as changes in material or manufacturing processes.

Modeling and simulation tools can be used to help evaluate a product’s producibility with technology that supports both product design and manufacturing engineering. The use of these tools can assist the manufacturing team in designing the manufacturing process for a product design while in the early stages of development. The equipment, workflow, and overall process for manufacturing can be developed and evaluated for functionality, reliability, and safety at a fraction of the cost that would be required to actually perform the activities represented by the model. This up-front verification of designs also aids in the avoidance of costly field modifications, rework, and scrap. Some studies indicate that the use of modeling and simulation tools can result in significant manufacturing cost avoidance, including:

- 20-60% reductions in set-up time,
- 15-25% reductions in planned labor and tooling,
- 15-75% reductions in rework and scrap, and
- 20-50% reductions in work-in-progress carrying cost.

Each iteration of a component design can require tooling modifications in addition to the base costs of producing the actual component. An effective modeling system enables the simulation of this iterative process, thereby reducing the expense of tooling development trials. Modeling will reduce unit costs for complex components by eliminating the need to make multiple full-size trial parts to verify the method. Another benefit is the reduction in lead times for new components.

Simulation-based “what-if” analysis can be conducted offline to develop, evaluate, and/or improve manufacturing processes without contributing to production downtime. Use of these tools provides the capability to execute various operational scenarios, such as testing control strategies or evaluating the use of new materials, independent of normal operations.

The use of modeling and simulation makes developing and implementing new processes more efficient. The tools and techniques also provide a cost-effective means for improving product quality while reducing the costs and cycle times associated with product development.

References:

- Diamond, B. (1996). Concepts of Modeling and Simulation. PC AI Magazine.
- Gallaher, M., & Athiragan, P. (1996). Geometric modeling architecture for manufacturing-process simulation software. Product Modeling for Computer Integrated Design and Manufacture.
- Groff, G. K., & Muth, J. F. (1972). Operations Management: Analysis for Decisions.

F.1.14. Producibility Assessment Worksheet

The Producibility Assessment Worksheets (PAWs) are documentation of expert opinions on specific topics gathered from questionnaires or other non face-to-face means. They can be used to help an Integrated Product Team (IPT) identify problem areas that may be difficult to initially define. PAWs are structured to provide an easy means to identify these problem areas and help the IPT develop the course of action needed for resolution.

The PAW is an excellent example of a trade study tool. The PAW, which was presented in the 1993 “Producibility Measurement Guidelines,” assigns numerical values for each process element. When averaged, these indicate a measure of the probability of successful production. The producibility index is predicated on

subjective data, or information based on the evaluator's past experience with the product or similar product. The worksheet is, therefore, beneficial in a product's development stage because it is designed to communicate an evaluator's knowledge, experience, and expert judgment. The worksheet also accounts for what the evaluator knows about the product's design, as well as what resources may be used in production. This information is then shared with other members of the IPT to determine the likelihood of a product's successful production.

The basis of the PAW is the Delphi Technique. It is used as a means to compile the anonymous response of experts on the issues listed on the worksheet and as a tool to identify possible problems that might be encountered in manufacturing. The PAW is based on:

- **Anonymous Response:** Normally effected through the use of questionnaire, on-line computers, or other non face-to-face means. The IPT, however, can use both anonymous and face-to-face means.
- **Interaction and Controlled Feedback:** Conducted through a series of rounds between which a summary of the previous rounds results are communicated. If the assessments are initially completed anonymously, open discussions and feedback should occur after the IPT has collected the assessments.
- **Statistical Group Response:** After discussions, the IPT should have a good assessment as to the producibility of the part as designed.

The worksheets are simple, easy to use, and flexible enough to fit any manufacturer's individual needs or situation. PAWs have been developed for Source Selection, Circuit Card Assembly, Electrical, Mechanical, and Management. Figure F.4 is representative of the PAW methodology. Other PAWs can be developed to meet a company's needs. PAWs can be used for one single component or for a complete system. If needed, multiple PAWs can be used to yield a producibility measurement.

References:

Department of the Navy. (1993, December). Producibility Measurement Guidelines: Methodologies for Product Integrity.

F.1.15. Prototyping

Prototyping is a tool used for assessing form-fit-and-function of a product and for visualizing aesthetic quality. Prototyping techniques can also be used to create molds for full-scale production. Through use of a prototype, a designer can get feedback on design information and initial part acceptance for further use in optimizing the design and/or the manufacturing process(es). Prototyping is used to check design features and complexity and is helpful in tradeoff studies. The use of prototyping begins in the preliminary design step and continues into the early stages of the final design step. The ability to quickly transform a design into a three-dimensional solid model or prototype can significantly streamline the design and product development process, while substantially reducing costs.

Product prototyping falls into two categories: virtual and physical. Virtual prototyping, more commonly referred to as modeling and simulation (discussed in more detail in Appendix F.1.13), is a software-based engineering technique that entails computer modeling a product and then simulating and visualizing its behavior in three-dimensional, real-world operating conditions. Modeling and simulation enables the refining and optimizing of the design through iterative design studies and is of use as a preliminary step to physical prototyping.

Physical prototype fabrication is a test of a product design. Physical prototyping is used to test fabrication feasibility, check feature designs, and test material and product properties. Physical prototype fabrication falls into three categories: subtractive, compressive, and additive processes.

Subtractive Process: In a subtractive process, a block of material is carved out to produce the desired shape. Most conventional prototyping processes fall into the subtractive category. Subtractive processes normally used to fabricate prototypes include milling, turning, and grinding.

Assessment Candidate _____					
Production Method (PM) _____					
1. _____					
2. _____					
3. _____					
4. _____					
	Method	PM#1	PM#2	PM#3	PM#4
A1 Design					
.9	Existing/simple design	_____	_____	_____	_____
.7	Minor redesign/increase in complexity	_____	_____	_____	_____
.5	Major redesign/moderate increase complexity	_____	_____	_____	_____
.3	Tech. avail. complex design/significant increase	_____	_____	_____	_____
.1	State-of-the-art research req./highly complex	_____	_____	_____	_____
A2 Process					
.9	Process is proven and technology exists	_____	_____	_____	_____
.7	Previous experience with process	_____	_____	_____	_____
.5	Process experience available	_____	_____	_____	_____
.3	Process is available, but not proven yet	_____	_____	_____	_____
.1	No experience with process, needs R&D	_____	_____	_____	_____
A3 Materials (Availability)					
.9	Readily available	_____	_____	_____	_____
.7	1-3 month order	_____	_____	_____	_____
.5	3-9 month order	_____	_____	_____	_____
.3	9-18 month order	_____	_____	_____	_____
.1	18-36 month order	_____	_____	_____	_____
A4 Cost Goals					
.9	Budget not exceeded	_____	_____	_____	_____
.7	Exceeds 1-5% of cost goals	_____	_____	_____	_____
.5	Exceeds 5-20% of cost goals	_____	_____	_____	_____
.3	Exceeds 20-50% of cost goals	_____	_____	_____	_____
.1	Cost goals cannot be achieved >50%	_____	_____	_____	_____
A5 Schedule Compliance (Tailor for program)					
.9	Negligible impact on program	_____	_____	_____	_____
.7	Minor slip	_____	_____	_____	_____
.5	Moderate slip	_____	_____	_____	_____
.3	Significant slip	_____	_____	_____	_____
.1	Major slip	_____	_____	_____	_____
Producibility Assessment Ratings		PM#1 _____	PM#2 _____	PM#3 _____	PM#4 _____
For each method $\frac{(A1+A2+A3+A4+A5)}{5}$ = Producibility Assessment Rating for that Method					

Figure F.4 - Universal PAWExample

Compressive Process: A compressive process forces a semi-solid or liquid material into the desired shape, in which it is then induced to harden or solidify. Compressive processes include casting, molding, and powder metallurgical processes. Compressive processes tend to be the most time-consuming of physical prototyping processes. They require the production of a mold and cannot be used to produce high aspect ratio features. Compressive process prototypes can be produced with a wide variety of materials, but care must be taken to ensure 100% dense products if physical testing of the prototype is desired.

Additive Process: An additive process builds an object by joining particles or layers of raw material. The new rapid prototyping technologies (discussed in more detail in Appendix F.1.17) are additive processes. The integration of rapid prototyping into the compressive process category has resulted in the capability to more rapidly generate patterns from which molds are made. In general, prototypes produced using rapid prototyping cannot be used for physical testing of the design but can be used to check design features and complexity issues.

In addition to product prototyping, processes can be prototyped. While more often referred to as process verification or process trials, process prototyping is conducted to gain insight into whether a process can be utilized in the production of a particular product or product line and to optimize process parameters for the production of that product. Although it is very similar to product prototyping, the emphasis is on the process – process verification and process optimization. Process verifications are often performed as part of the trade studies in integrated product and process development. They are also performed, as the design matures, on any intended production process for parameter development or optimization. Verifying process capabilities through process prototyping can help reduce the risks associated with committing to production and investing in tooling and fixtures for an untested process or a new part design. Production benefits resulting from process verifications include the production of more accurate parts, a reduction in rework and scrap, cost savings, and, possibly, the avoidance of a deleterious impact to schedule.

References:

- Alting, L., & Boothroyd, G. (1994). Manufacturing Engineering Processes. Marcel Dekker.
- Fellers, W.O., & Hunt, W.W. (1994). Manufacturing Processes for Technology. New York: Prentice-Hall.
- Haas, R., & Teixeira, A. A. (1995). Virtual Prototyping: Virtual Environments and the Product Design Process. Chapman & Hall.
- Ostwald, P. F., & Munoz, J. (1996). Manufacturing Processes and Systems. New York: Wiley & Sons.
- Wood, L. (1992). Rapid Automated Prototyping: An Introduction. New York: Industrial Press.
- Wright, J. R., & Hessel, L. D. (1996). Manufacturing Processes. Delmar Publishers.

F.1.16. Quality Function Deployment

Quality Function Deployment (QFD) is a team-based systematic and iterative process used to address and fine tune the requirements and needs of customers. The primary goal is satisfying the customer's requirements. Once the customer's requirements are identified, they are then translated into specifications for product planning, design, process and production. QFD is a team approach to determine objectives, the best method to accomplish the objectives, the process to be used, and the resources needed.

A major benefit of QFD is that communication is enhanced throughout the product development process. This enhanced communication leads to a more effective decision-making process. Short-term benefits include reducing cross-functional barriers associated with product development teams and aiding changes in corporate

culture. Long-term benefits include reduced development costs, reduced overall cycle time, and increased productivity.

QFD can be used as a blueprint for implementing Integrated Product and Process Development (IPPD) (see Appendix F.1.8) and to reduce lead-times, startup costs, and engineering changes. It is also used to develop new products and services.

The QFD process is a structured procedure that begins with identifying the qualities desired by the customer and then the steps and means necessary to provide the product. It enables a great deal of information to be summarized in the form of easy-to-interpret charts.

The process uses a series of interrelated matrices to convert customer needs to process steps. QFD matrices relate the data produced in one stage to the decision that must be made at the next process stage. The QFD House of Quality (Figure F.5) shows the process for developing these matrices.

The "What"s are the product characteristics, functions, or level of performance wanted by the customer. The "How"s are the ways to accomplish the "What"s. The "How to What" is the relative strength relationship between the two. The "Importance Rating" denotes the importance of each "How." Through this process, input from all team members is considered to develop an overall recommendation on how to proceed to meet customer requirements.

References:

Akao, Y. (Ed.). (1990). Quality Function Deployment. Cambridge, MA: Productivity Press.

Cohen, L. (1995). Quality Function Deployment: How to Make QFD Work for You. New York: Addison Wesley Publishing Company.

Day, R. G. (1993). Quality Function Deployment: Linking a Company with Its Customers. Milwaukee, WI: American Society of Quality Control Quality Press.

Eureka, W. E., & Ryan, N. E. (1994). The Customer-Driven Company: Managerial Perspectives on Quality Function Deployment (2nd ed.). Dearborn, MI: ASI Press.

Guinta, L. R., & Praizler, N. C. (1993). The QFD Book: American Management Association. New York.

King, R. (1989). Better Designs in Half the Time: Implementing Quality Function Deployment in America. Methuen, MA.

Marsh, S., Moran, J. W., Nakui, S., & Hoffherr, G. (1991). Facilitating and Training in Quality Function Deployment. Methuen, MA.

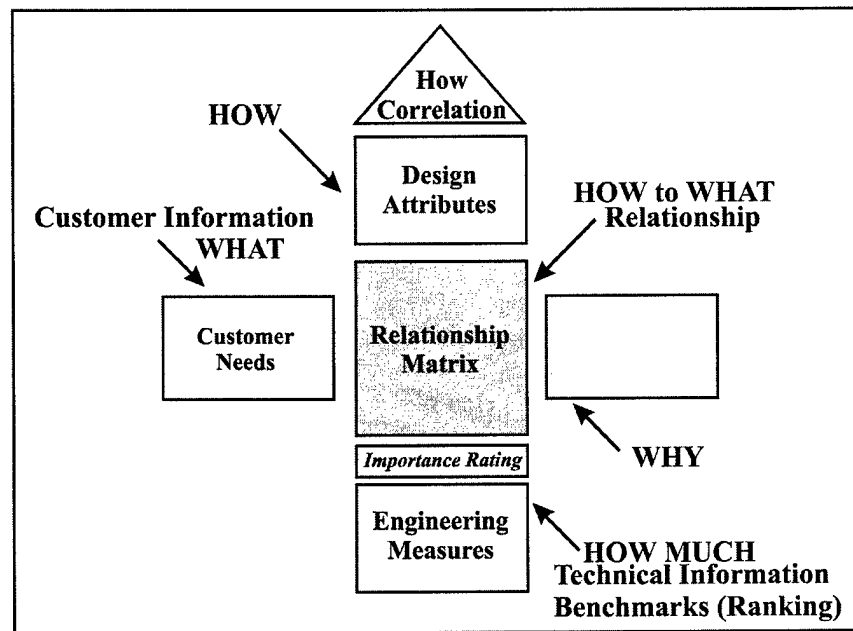

Figure F.5 - QFD House of Quality

Mizuno, S., & Akao, Y. (Eds.). (1994). QFD: The Customer-Driven Approach to Quality Planning and Development. White Plains, NY: Quality Resources.

Shillito, M. L., & Marle, D. J. (Ed.). Value, Its Measurement, Design, and Management. New York: John Wiley & Sons, Inc.

F.1.17. Rapid Prototyping

Product prototyping (as discussed in F.1.15) is an essential part of the product design cycle. It is a technique for design functionality and aesthetic quality assessment. Through use of a prototype, a designer can get feedback on design information and initial part acceptance for further use in the manufacturing process. Prototyping is used to check design features and identify complexity issues and is helpful in tradeoff studies.

The use of prototyping begins in the preliminary design phase and can continue throughout the early stages of the detailed design. Prototyping can also be performed in production to test whether a new process can be used to produce a product that meets the customer's quality requirements. The ability to quickly transform a design into a three-dimensional solid model or prototype can significantly streamline the design and product development process, while substantially reducing costs.

Rapid prototyping may also be used early in the product development cycle, before tooling has been developed, to provide visualization and verification feedback. This allows the designers to evaluate and refine a design prior to manufacturing, as well as to accelerate the production of prototype molds and tooling.

Traditional prototyping is time-consuming and costly. For this reason, rapid prototyping has emerged as a breakthrough process in the product design cycle. While conventional prototyping may take weeks or even months, rapid prototyping turnaround time for a typical part is usually no more than a few days. If the CAD models of the part exist beforehand, turnaround time can be less than 24 hours for smaller parts.

The two most widely used rapid prototyping processes are StereoLithography (SLA) and Selective Laser Sintering (SLS). SLA uses a photopolymer process to create complex, three-dimensional models by successively "laser-curing" cross-sections of liquid resin, using data from virtually any surface or solid modeling CAD system. The liquid photopolymer hardens in the specific areas where there is interaction with the ultraviolet (UV) laser beam, and the model is built layer-by-layer, without tooling, programming, or machining.

SLS is a similar process that makes use of a laser to elevate the temperature of a heat-fusible powder to near its melting point to fuse the particles in solid form. Like SLA, SLS is a three-dimensional process that vertically builds the part layer-by-layer. With either method, the transition from CAD data to physical part can take place in a matter of hours.

Specific attributes of SLA and SLS include:

- **Surface finish:** The surface finish of SLA is superior to that of SLS due to the formation of voids between particles during the SLS process.
- **Small feature definition:** Both SLA and SLS are capable of producing features in the range of 0.010 inches. The accuracy of the parts will be dependent on part geometry and material choice.
- **Material selection:** While SLA is only applicable to polymeric resins, SLS can be used on a range of materials including nylon, polycarbonate, resins, and wax. Research is currently ongoing to apply the SLS process to metals.

While SLS shows promise for future development, SLA is the more popular rapid prototyping technique in use today. The main components of a SLA system include: a vat containing liquid photopolymer, galvanometer controlled mirrors which direct a UV laser onto the surface of the liquid, and, just below the surface of the liquid, a vertical elevator tray. At the onset of the SLA process, the first layer of the part model is generated in software, and this information is used to control the mirrors to direct the laser onto the surface of the liquid resin. Where the laser strikes, the liquid turns to a solid almost instantaneously. When one layer has finished, the elevator lowers to submerge the newly solid top surface with liquid resin for the next layer. The next layer is generated

in software, and, again, the mirrors direct the laser onto the surface of the resin. This process is repeated until the model has been built, at which time it will be fully submerged in liquid resin. The elevator is raised, and the model removed for post-curing and clean-up.

Rapid prototyping is used widely to accelerate the product development process. Design engineers across all manufacturing industries have used rapid prototyping to improve product quality. Form, fit, and function tests can be performed earlier in the design cycle, thereby reducing costly engineering changes required after production has begun.

References:

Jacobs, P. F. (1996). StereoLithography and Other RP&M Technologies: From Rapid Prototyping to Rapid Tooling. Society of Manufacturing Engineers.

Kai, C. C., & Fai, L. K. (1997). Rapid Prototyping: Principles and Applications in Manufacturing. New York: Wiley & Sons.

Kochan, D. (1993). Solid Freeform Manufacturing: Advanced Rapid Prototyping. New York: Elsevier Science.

Wood, L. (1992). Rapid Automated Prototyping: An Introduction. New York: Industrial Press.

F.1.18. Risk Management Tools

Risk is common to any product development effort. A risk is the potential inability of achieving product goals and is quantified by the probability of a failure and the consequences of that failure. Risk management includes risk identification and assessment, tracking of risks to determine how risks have changed, and mitigation/reduction of risk impact on the product.

Risk management activities begin at the outset of any product development effort and continue through all phases. They are important elements in achieving a producible design. Although the scope and method of implementation will vary with product scope and complexity, among other things, common threads of any risk reduction effort are:

- **Risk identification:** What process improvements are needed to ensure that producibility will be achieved? Do design analysis processes include a producibility assessment? Do trade study activities include producibility as a tradeoff criterion?
- **Risk assessment:** What consequences will result if identified areas of risk are not dealt with or are only partially addressed? Will the impact affect performance, cost, and/or schedule, and to what degree?
- **Risk tracking:** Is an unmitigated risk growing? By when must the risk be mitigated?
- **Risk mitigation/reduction:** What can be done to eliminate the source of the risk or reduce it to an acceptable level? Are funds available to develop and conduct the necessary risk mitigation efforts?

Examples of risk management tools include: (1) the Navy-developed, knowledge-based and process-oriented Technical Risk Identification and Mitigation System (TRIMS); (2) the commercially available Schedule/Cost Risk Analysis Module (SCRAM! 3.0), a risk analysis/decision support tool that adds probabilistic duration, cost, and logic analysis capabilities to Microsoft (MS) Project; and (3) RiskTrak, a commercially available, Windows-based, networked software tool that enables an organization to identify, estimate, analyze, communicate, and report risk throughout the duration of any product development.

TRIMS, one of several electronic tools comprising the Navy-developed Program Manager's WorkStation, helps users identify, quantify, and track program risks as well as document and track mitigation plans addressing those risks. It was developed as part of the Navy's Best Manufacturing Practices (BMP) program for addressing manufacturing risk and can be accessed through the BMP Internet site. TRIMS is based on proven risk models (such as those from the Software Engineering Institute), on published practices, and on the

Navy's Best Practices templates and is applicable throughout all phases of both military and commercial programs.

TRIMS capitalizes on past experiences and identified best practices. It incorporates the factors of probability and effect – the probability that a problem or failure will occur and the effect on a product development if it does. Because TRIMS is knowledge-based and process-oriented, its baseline templates are product-independent and can be applied with equal effectiveness to most hardware or software systems. TRIMS incorporates several knowledge bases including Systems Engineering, Software Design, and Testability.

References:

Risk Management Guide for DoD Acquisition (2nd ed.). (1999). Fort Belvoir, VA: Defense Systems Management College Press.

F.1.19. Root Cause Analysis

Root Cause Analysis (RCA) is a method or series of actions taken to identify the reasons why a particular failure or problem exists and to highlight alternative solutions to eliminate the sources of those problems. An analysis of the comparative benefits and cost-effectiveness of the alternative solutions aids the decision maker in implementing the most beneficial course of action. RCA goes beyond identifying resolutions for the symptoms of a problem. It aims to provide solutions to eliminate the root cause of the problem to ensure that the problem can never occur or recur.

The use of RCA is a systematic process of gathering all relevant data about a problem, including its internal causes. When a problem occurs, there are several ways it can be addressed. A common method is to resolve the symptoms of the problem and hope it does not occur again. The preferable method, however, is to get to the root cause of the problem and permanently eliminate it. RCA is used to determine the root cause and to present the decision maker with alternatives that can be analyzed to determine the optimal solution.

With regard to producibility, performing RCA can help identify sources of problems that can be designed out of the final design, thereby reducing rework and improving quality in production. Root cause analysis can also be used to determine causes of problems in manufacturing – causes of process variation or product quality problems.

The process for root cause analysis entails first defining the specific problem to be addressed and then defining each mode in which the problem occurs. Data is then collected, and the analysis of the problem begins by defining the hypotheses of how the various failure modes could have occurred. Next comes the verification of the hypotheses to identify which failure mode was responsible for the problem. The results are tracked until a final conclusion as to the root cause of the problem is determined.

Cause and effect diagrams, sometimes called fishbone diagrams, are used to help identify the causes of a problem. An example of a fishbone diagram is shown in Figure F.6. The objective is to resolve the problem, or effect, by performing a thorough investigation of all of its possible causes. The effects are the particular quality characteristics or problems that are being encountered, such as "heat" in the example. The causes are the factors that influence the stated effects, such as, in this case,

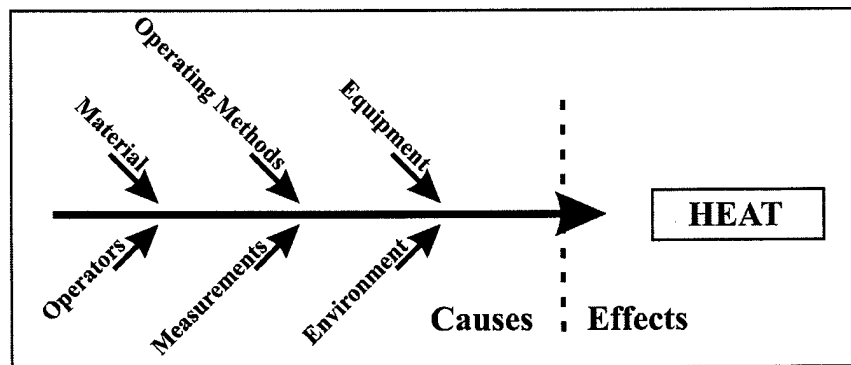

Figure F.6 - Cause and Effect Diagram

the material, equipment, operating methods, operators, or environment. Typically, in manufacturing, problems or effects can be related to quality, process variability, cost, schedule, safety, etc.

Throughout the process of developing the diagram, the use of brainstorming sessions can help lead to new ideas that can help better understand and identify the actual root cause of the problem.

References:

- Ammerman, M. (1998). The Root Cause Analysis Handbook: A Simplified Approach to Identifying, Correcting, and Reporting Workplace Errors. New York: Quality Resources.
- Ishikawa, K. (1982). Guide to Quality Control. Asian Productivity Organization.
- Joiner Associates, Inc., Staff. (1995). Cause-and-Effect Diagrams: Plain and Simple. Oriol, Inc.
- Latino, R. J., & Latino, K. C. (1999). Root Cause Analysis: Improving Performance for Bottom Line Results. CRC Press, Inc.
- Tromp. (1997). Root Cause Analysis RCA. Kendall/Hunt Publishing Company.
- Wilson, P. (1992). Root Cause Analysis/Workbook H0701a. ASQ Quality Press.
- Wilson, P. F., Del, L. D., & Anderson, G. F. (1993). Root Cause Analysis: A Tool for Total Quality Management. ASQ Quality Press.

F.1.20. Six Sigma

Six Sigma is a quality approach used to strive for zero defects in production. It is used as a management strategy for initiating comprehensive reviews of products and processes. The goal of Six Sigma is to reduce the defects to a maximum of 3.4 defects per million opportunities (dpmo), or 99.99966 percent acceptance. Since it is not possible to achieve a defect free process in the real world, Six Sigma is used to set a high standard for measuring quality performance. By reducing the number of defects, or total defects per unit (DPU), it becomes possible to produce more accurate products and, therefore, improve producibility.

The term sigma is a statistical term that means standard deviation. With Six Sigma, the total DPU is translated into a standard deviation value. The sigma value indicates how often defects are likely to occur. The higher the sigma value, the less likely a process will produce defects. A company that has successfully implemented Six Sigma will spend one percent, or less, of each sales dollar on the cost of non-conformance. Most companies in the U.S. industrial base operate near the four sigma level and spend as much as 25 percent of each sales dollar on the cost of non-conformance.

If process capabilities are known, the methods and tools provided by the Six Sigma approach can help an organization understand, predict, and avoid the occurrence of defects in its products while they are still in the design phase of the product development process. As stated above, the total DPU output of a process is converted to a standard deviation. Process capability is expressed as the *capability index*, which compares the output of the process (DPUs converted to standard deviation) to that of the process tolerance. The process tolerance is defined as six standard deviations, or Six Sigma. There are two capability indexes used to define process capabilities. C_p is the capability index of the

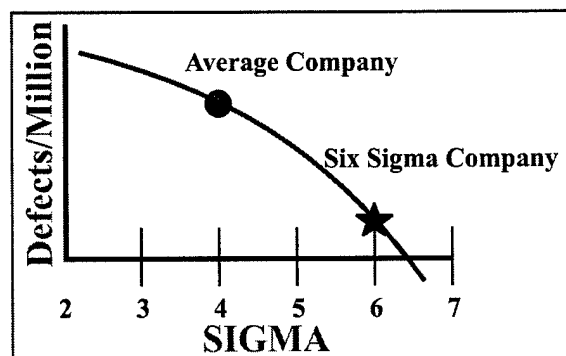

Figure F.7 - Sigma

nominal target process. It is the ratio of design tolerance to Six Sigma process variability. C_{pk} is C_p adjusted for the difference between the nominal process mean and the actual process mean.

For an organization determined to raise its standard of acceptable products and processes, use of the Six Sigma approach is an excellent means for accomplishing this goal. The benefits of incorporating this methodology include: improved production cycle times; reduction in errors, rework, and scrap; and gains in productivity. These benefits translate into improved product performance and reliability as well as lower product development costs.

Although the process of Six Sigma can be involved, the payoffs to producibility are significant. There are numerous training courses, software tools, reference materials, and consultants available to assist in its implementation.

References:

- Breyfogle, F.W. (1999). Smarter Six SIGMA Solutions: Statistical Methods for Testing, Development, Manufacturing, and Service. New York: John Wiley & Sons, Incorporated.
- Harry, M. J. (1988). Six Sigma Mechanical Design Tolerancing. Motorola University Press.
- Harry, M. J. (1988). The Nature of Six Sigma Quality. Motorola University Press.
- Massy, M. J. (1992). Six Sigma Producibility Analysis and Process Characterization. Massachusetts: Addison-Wesley.
- Perez-Wilson, M. (1999). Six Sigma: Understanding the Concept, Implications and Challenges. Advanced Systems Consultants.

F.1.21. Statistical Process Control

Statistical Process Control (SPC) is a method that uses statistical tools and techniques to monitor, control, and improve the product development processes. There are several basic premises behind this method, including the fact that there will always be some variation between two products, even when produced using the same processes. This variation will occur in a definite pattern, which can be used to identify process abnormalities or impending failures. The SPC method provides a means for measuring and analyzing variations in process capabilities, which, in turn, can identify opportunities for process correction. This methodology is often included as part of a larger Statistical Quality Control (SQC) initiative (discussed in Appendix F.1.22), the objective of which is to improve product quality by improving the quality of the related manufacturing processes. Successful implementation of SPC results in increased production throughput, decreased manufacturing defects, and improved quality.

Process and product variation is expected and can be attributed to variations in one or more of the following: materials, equipment, methods, environment, and personnel. The causes of variation can be categorized into two types: (1) chance or system causes which are those built-in process characteristics that are beyond human control and cannot be corrected and (2) assignable or special causes which are those process anomalies that can be detected and corrected. In order to maintain or improve product quality, assignable causes for variation should be minimized or, ideally, eliminated from the product manufacturing process.

The first step in the SPC method is to capture process variation under normal, stable conditions in which all controllable sources of variation have been eliminated. A histogram, or frequency distribution, is used to measure and analyze process variation. When used for analyzing process capability, a frequency distribution is a count of the number of times a particular measurement occurs as a result of the process. A histogram (Figure F.8) is bar graph depiction of a frequency distribution. When all assignable causes for variation have been eliminated, the measurements will tend to be somewhat evenly distributed around an average value. Ideally, this average value will equal the measurement required in the applicable specifications. Standard deviations,

also referred to as sigma, describe how the measurements fit around the average. Any variation induced by any of the factors noted above will distort the normal distribution of the measurements.

Because frequency distributions and histograms provide a snapshot depiction of a process, they should not be used to analyze a continuous manufacturing process. Instead, a control chart should be used. There are two types of control charts – variable and attribute. An average and range chart (X-bar, R chart), shown in Figure F.9, is a variable control chart that is used to determine how the average output of a process compares to specified requirements. An attribute chart is best suited when conducting “pass/fail” types of inspections. When used properly, both types of control charts provide an immediate visual indication of when a process is operating outside of previously specified limits and in need of corrective action.

Once all assignable causes have been eliminated from a process, the capability of the process is determined and expressed numerically as the capability index or the capability ratio. Both numbers are based upon the process tolerance, which is equal to six standard deviation (Six Sigma) of the process distribution. Many companies are adopting the Six Sigma approach, which converts the total defects per unit to a standard deviation as a process and quality improvement technique. (Six Sigma is discussed in Appendix F.1.20.)

Once a process problem has been identified using the tools above, other techniques, such as cause and effect diagrams and Pareto analysis, are used to help decide what corrective actions should be taken. Cause and effect diagrams are often used by teams as a brainstorming tool to identify the potential sources of process variation. Pareto analyses can be used to establish priorities for solving problems.

To achieve maximum benefits, SPC methods must be integrated into a company’s normal way of doing business. When successfully implemented, SPC will aid in optimizing production processes and capabilities, thereby improving the overall quality of products.

References:

Burr, I. W. (1976). Statistical Quality Control Methods. New York: Marcel Dekker, Inc.

Doty, L. A. (1996). Statistical Process Control. Industrial Press.

Evans, J. R. (1991). Statistical Process Control for Quality Improvement: A Training Guide to Learning SPC. Prentice Hall.

Grant, E. L., & Leavenworth, R. S. (1988). Statistical Quality Control (6th ed.). New York: McGraw-Hill Book Company.

Montgomery, D. C. (1985). Introduction to Statistical Quality Control. New York: John Wiley & Sons.

Oakland, J. S. (1996). Statistical Process Control: A Really Practical Guide. Butterworth-Heinemann.

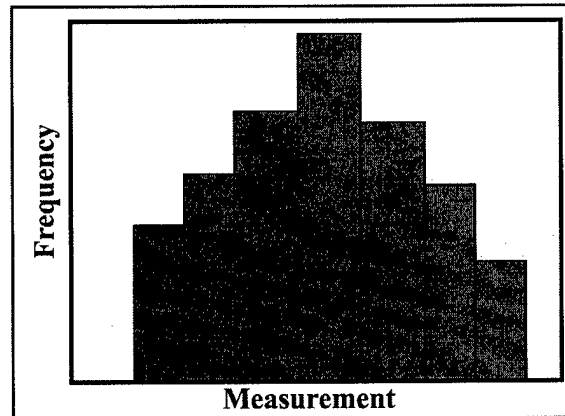

Figure F.8 - Histogram Example

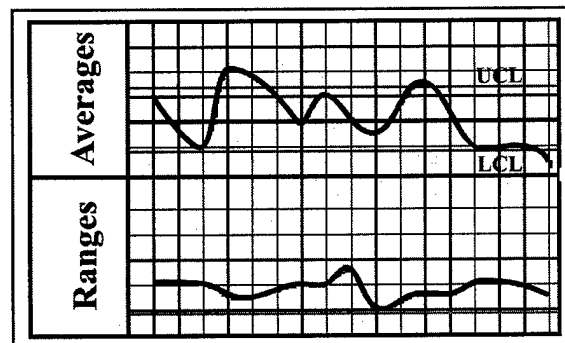

Figure F.9 - Control Chart Example

Rhyder, R. F. (1997). Manufacturing Process Design and Optimization. New York.

Smith, G. M. (1997). Statistical Process Control and Quality Improvement. Prentice Hall.

Wheeler, D. J., & Chambers, D. S. (1992). Understanding Statistical Process Control (2nd ed.). Knoxville, TN: SPC Press.

F.1.22. Statistical Quality Control

As a means of improving and maintaining competitiveness within the global market, enterprises are placing a greater emphasis on improving the quality of products provided to the consumer. To achieve this objective, organizations are looking for ways to improve the quality of manufacturing processes. Many world-class organizations have adopted Statistical Quality Control (SQC) which involves using statistical tools and techniques, such as acceptance sampling, process capability analysis, and Statistical Process Control (SPC), to analyze, monitor, and control the efficiency and quality of its manufacturing processes. By improving the quality of the manufacturing processes used in production, the quality of the end-product increases, which in turn improves productivity and customer satisfaction.

A key concept of SQC is recognizing that process and product variation is a normal occurrence and should be expected. The causes of variation are categorized into two types: (1) variation that is built into the process and cannot be corrected and (2) variation caused by external sources that can be controlled, such as material, equipment, methods, etc. SQC can be used to quantify process variation and determine an acceptable level of variation for manufacturing processes required to maintain or improve the quality of the final product. Techniques often used for Statistical Process Control, such as histograms and control charts, can be used to analyze and monitor the quality of manufacturing processes to reduce the amount of defective products being produced. (See Appendix F.1.21 - Statistical Process Control)

Acceptance sampling is often used to monitor the quality of products that are produced rapidly in large quantities. It is also used when the inspection method renders the product unusable. Because it is less expensive to implement and execute, acceptance sampling is often preferred over total (100 percent) sampling. Acceptance sampling can be used to determine either the quality of the product or whether the processes used to produce the product are operating within specified limits. There are some risks associated with using acceptance sampling, including the chance that an acceptable lot will be rejected or vice versa. These risks have been standardized and are expressed in terms of probability. The probability that an acceptable lot will be rejected due to sampling is referred to as the Producer's Risk (Alpha). The Consumer's Risk (Beta) is the probability that a lot that is defective will be mistakenly accepted. An

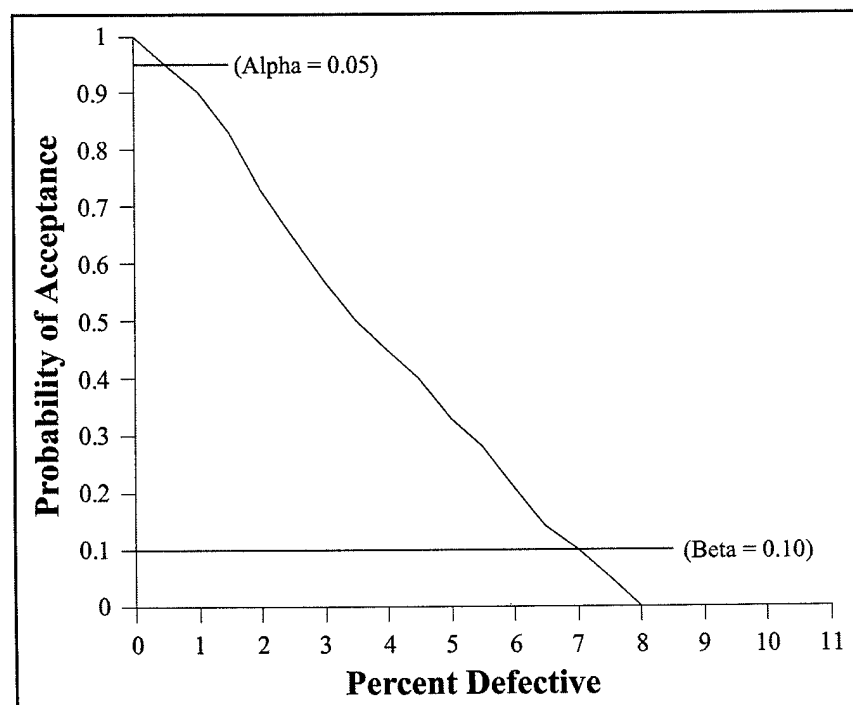

Figure F.10 - Sample OC Curve

Operating Characteristic (OC) curve (see Figure F.10) is used to graphically depict these numbers along with the probability that various levels of quality will be accepted under the sampling plan.

Another benefit to be gained from implementing SQC is the minimization of failure costs. Failure costs result from product defects and can be categorized as either internal failure costs or external failure costs. Internal failure costs result from defects that are detected after production is complete but prior to the product being sent to the customer. Internal failure costs include those associated with scrap and rework efforts, additional inspection and testing of repaired parts, as well as the labor hours spent trying to identify the cause of the defect. External failure costs result from defects being identified after the product has been provided to the customer and include the costs associated with complying with product warranties as well as the loss of revenue due to customer dissatisfaction. SQC tools and techniques can be used to ensure the production and delivery of high quality products, thereby reducing failure costs.

When successfully implemented and executed, SQC tools and techniques provide a reliable method for analyzing and controlling production processes to ensure that quality parts are produced. When manufacturing processes are under control, product and process variation is minimized, and the overall quality of the end product increases. Higher quality products and processes result in increased productivity and customer satisfaction, which improve competitiveness within the global market.

References:

Hart, M. K., & Hart, R. F. (1989). Quantitative Methods for Quality and Productivity Improvement. Milwaukee, WI: ASQC Quality Press.

Ishikawa, K. (1986). Guide to Quality Control. Ann Arbor, MI: UNIPUB.

Juran, J. M., & Gryna, F. M. (1988). Juran's Quality Control Handbook. New York: McGraw-Hill.

Maleyeff, J. (1994, December). The Fundamental Concepts of Statistical Quality Control. Industrial Engineering.

Schuetz, G. (1996, February). Bedrock Statistical Quality Control. Modern Machine Shop.

F.1.23. Tolerance Analysis

Tolerance analysis looks at the relationship of design tolerance (requirement) and manufacturing variation (process capability) to define an optimal tolerance solution. The method of tolerance analysis will depend upon the method of manufacture and the tolerance range within which the parts may vary. The key concept of tolerance analysis is the interchangeability of parts. If two parts can be switched in an assembly, they are considered to be interchangeable. In terms of fit, these parts are considered to be the same. Tolerance analysis will determine the limit to which these parts can vary and still be considered interchangeable. As the tolerance range approaches zero, the cost of manufacturing the part increases greatly. Therefore, the goal of tolerance analysis is to generate parts with as loose a tolerance as possible to minimize the production cost while still meeting the conditions for interchangeability. From a producibility standpoint, maximizing design tolerances is a necessity for a robust design.

There are several types of tolerance analysis methods available depending upon the complexity of the assembly and how conservative the design requirements are. Following are examples of tolerance analysis techniques:

Arithmetic Worse Case (AWC): AWC analysis is a straightforward linear addition and subtraction of worse case tolerances. From a design standpoint, AWC is the most conservative of the techniques. It does not consider the statistical probability of interference fit or process capability, but focuses instead on design specifications. Generally, worse case analysis should not be used when the number of parts in the assembly is greater than four.

Root Sum of Squares (RSS): RSS analysis produces less conservative results than AWC tolerance analysis. RSS assumes that the design tolerance will fall within centered Six-Sigma limits. This analysis exploits the manufacturing probability that a part will tend more toward the median level of design dimension instead of the maximum or minimum limits. It does not take into account process mean shifts.

Dynamic Root Sum of Squares (DRSS) and Static Root Sum of Squares (SRSS): These analyses factor process mean shifts into the analysis and, therefore, produce less conservative results than RSS. Process shifts at the component levels can, thereby, result in fit-up problems at the assembly level. DRSS inflates the assembly standard deviation but has little impact on the overall assembly mean (random process mean shift). SRSS assumes sustained mean shift conditions of each component in the assembly.

References:

Boyd, R. R. (1993). Tolerance Analysis of Electronic Circuits Using MATLAB. New York: CRC Press.

Cox, N. D. (1986). How to Perform Statistical Tolerance Analysis, Vol. 11. ASQ Press.

Meadoews, J. D. (1995). Geometric Dimensioning and Tolerancing: Applications and Techniques for Use in Design, Manufacturing, and Inspection. New York: Marcel Dekker.

Zhang, H. (1997). Advance Tolerancing Techniques. New York: Wiley & Sons.

F.2. *Producibility Software*

Software applications that can aid in enhancing producibility are numerous. In this appendix, available software for some of the producibility tools and techniques discussed in this guidelines document are presented in Figure F.11. This software is grouped into the following categories:

F.2.1 Design for Assembly

F.2.2 Statistical Process Control / Statistical Quality Control

F.2.3 Simulation

F.2.4 Tolerance Analysis

F.2.5 Miscellaneous Producibility Software

It should be noted that maintaining an up-to-date list of software applications that address producibility is impossible, because techniques are continuously refined and software applications are updated or are newly introduced on a frequent basis. This list of available software is provided only as a starting point. The reader is encouraged to gather additional information through Internet searches, the use of consultants, producibility workshops, etc.

F.2.1. *Design For Assembly*

Design for Assembly (DFA) software allows users to simulate and model process parameters and assembly issues during the entire design phase, from conceptual design to detailed specifications of tolerance, form, fit, function, costing, and manufacturing. The software provides a systematic approach to analyze and evaluate each component and assembly as it relates to identifying assembly procedures, an optimal sequence of operation, operation cycle-time, and recommendations for redesign. The software provides cost data, design guidance, and producibility analyses to capture manufacturing process knowledge and use that knowledge to identify and reduce costs at every stage of a product's life-cycle. These applications work with part geometry from feature-based CAD models as input to the software. The software examines fundamental design issues and anticipates ease of assembly and manufacturing efficiency and provides preliminary cost estimates early in the design phase.

F.2.2. Statistical Process Control and Statistical Quality Control

A fully integrated statistical process control (SPC)/statistical quality control (SQC) system will merge design, manufacturing engineering, and production management systems, such as MRP II systems, Enterprise Resource Planning (ERP) systems, and Manufacturing Execution Systems (MESs). The integrated systems will evaluate and control production processes as well as monitor plant productivity and quality assurance. The system will collect critical production data from the plant floor and will maintain inspection data in a database. Based on preset control limits, an automated integrated system is able to monitor and detect deviation from target values and schedule maintenance activities based on rate of variation from target over time. An integrated system will also present critical production information in statistical process control and statistical quality control charts, graphics screens, and reports.

F.2.3. Simulation

Simulation software provides interactive 2D or 3D graphics simulation capability for engineers, operations researchers, and other analysts to model conceptual and detail designs from design through manufacturing planning to production operations. Users may change the model to perform "what if" analyses and run cost tradeoff studies to evaluate manufacturing systems design iterations and alternatives before building prototypes or modifying existing designs. The analysis allows the user to optimize critical plant floor design parameters, including capacity, throughput, cycle-time, production yields, costs, and quality measurements. On machining operations, the model can simulate machine tool motions as they occur on the shop floor. It can work with numerical control programs to identify over-travel and detect potential collision problems, and can then compare the simulated part against the design model to highlight any overcut and undercut conditions. Work cells can be simulated by using libraries of manufacturing resource components and models such as human operators; materials, parts and components; and equipment such as robots, machine tools, cutting tools, work benches, positional tables, gantries, and weld guns.

F.2.4. Tolerance Analysis

Tolerance analysis software allows users to perform tolerance analysis and tolerance allocation to help identify all contributors to both geometric and dimensional tolerances that impact manufacturing processes and cost. This software provides the capability to evaluate tolerance specifications of design to avoid and reduce chances of assembly interference between adjacent mating components. Potential stack-up tolerances between mating parts in a complex assembly can also be analyzed. Percent contribution and sensitivity of critical dimensions in assembly can be calculated to changes in individual constraints. As tolerances are updated or changed, the changes are compared and evaluated against the datum schemes for their impact on form, fit, and function. Quantitative impact on design decisions are evaluated for cost and producibility analysis. The software also allows users to compare measured data from an inspected part or assembly against original CAD design tolerances. It can perform Go/No-Go checks and recommend rework for out-of-tolerance conditions.

F.2.5. Miscellaneous Producibility Software

The following is a listing of Miscellaneous Producibility Software. This category includes software for Quality Function Deployment, Failure Mode and Effects Analysis, Risk Management, Design Tradeoff Analysis, and Complexity Analysis.

Product	Company	Telephone	Fax
Design for Assembly (DFA)			
CIMBridge (V.3.2)	Mitron Corporation (subsidiary of GenRad, Inc.)	800-929-4704 503-624-1776	503-968-1666
Cost Advantage (V.1.8)	Cognition Corporation	617-271-9300	617-271-0813
Design for Assembly (DFA) (V.8.1)	Boothroyd Dewhurst, Inc.	401-783-5840	401-783-6872
DFM Workbench (V.1.0)	Avant! Corp.	510-413-8000	510-413-8080
Mechanical Advantage II (V.4.1)	Cognition Corp.	617-271-9300	617-271-0813
Scepter Software	Royal Digital Centers, Inc.	408-323-8080	408-323-8082
SEER-DFM (Design For Manufacturability) (V.2.0)	G A SEER Technologies (division of Galorath Associates)	310-414-3222	- - -
Statistical Process Control (SPC) / Statistical Quality Control (SQC)			
ANSTAT	Quality Measurement Systems Corp.	315-986-5710	315-986-2115
Automated Product Tracking	Macatawa Computer Services, Inc.	800-400-2430	616-392-6941
AutoTrans (V.4.0)	Major Micro Systems, Inc.	248-350-9177	248-350-9274
CELLworks SPC Server	FASTech Integration, Inc.	800-380-FAST 781-259-3131	781-259-3188
CIMNET Folders (Computer Integrated Manufacturing NETWORK)	J.N.L. Industries, Inc.	888-7-CIMNET 610-693-3114	610-693-5927
Citect	Ci Technologies, Inc.	888-CITECT-1 704-329-3838	704-329-3839
D/3 Distributed Control and Computing System (DCCS)	GSE Systems, Inc.	410-312-3500	410-312-3611
DBQ (Database for Quality) (V.2.0)	Murphy Software	800-892-3328 248-351-0900	248-351-0906
FIX SPC	Intellution, Inc. (subsidiary of Emerson Electric Co.)	800-526-3486 781-769-8878	781-769-1990
FIX Stats	Intellution, Inc. (subsidiary of Emerson Electric Co.)	800-526-3486 781-769-8878	781-769-1990
InTouch (V.6.0)	Wonderware Corp.	714-727-3200	714-727-3270
IQS Business System	IQS, Inc.	800-635-5901 440-333-1344	440-333-3752
ISO Achiever Plus	Infolmage, Inc.	800-864-5061 602-234-6900	602-234-6948
Lookout (V.3.7)	National Instruments Corp.	800-258-7022 512-794-0100	512-794-8411
M-Ware Manufacturing Execution System	Applied Statistics, Inc. (ASI)	800-207-5631 612-481-0202	612-481-0410
MagicWindow SPC Software	The Crosby Co.	888-4CROSBY 630-790-1711	630-790-1768
MONITROL (V.4.0)	Hilco Technologies, Inc.	800-334-4526 314-298-9100	314-298-1729
MRP9000 (V.3.6)	Intuitive Manufacturing Systems, Inc.	425-821-0740	425-814-0195
NWA Quality Analyst (V.5.1)	Northwest Analytical, Inc.	503-224-7727	503-224-5236
ONQuality	ONSPEC Automation Solutions	800-939-0439 916-853-2590	916-853-2585
OnTrack Manufacturing Execution Systems (MES/EM)	RWT Corp.	847-390-0200	847-390-9433
Paragon 550 (V.5.0)	NemaSoft (subsidiary of Nematron Corp.)	800-331-2565 508-660-1221	508-660-2374
PFT (V.1.5)	Integrated Quality Dynamics, Inc.	800-870-4200 310-540-6142	310-540-6392
Point 3	Baystate Technologies, Inc.	800-372-3872 508-229-2020	508-229-2121
Process Window	Taylor Industrial Software Inc. (subsidiary of Total Control Products, Inc.)	403-420-2000	403-420-2049
QA/S GainSeeker SPC (V.5.2)	Hertzler Systems Inc.	219-533-0571	219-533-3885
QI Analyst	SPSS Inc.	800-543-2185 312-329-2400	312-329-3668
QMS Programs / ISO 9001 Certification Group	John A. Keane & Associates, Inc.	609-924-7904	609-924-1078
QMS Programs / ISO 9002 Certification Group	John A. Keane & Associates, Inc.	609-924-7904	609-924-1078
QMS Programs / Basic System Module & Database	John A. Keane & Associates, Inc.	609-924-7904	609-924-1078
Quality Analyst 9000 (V.3.0)	PowerWay, Inc.	800-964-9004 317-598-1760	317-598-1740
Quality Control and Industrial Experiments (V.10.0)	Lionheart Press, Inc.	602-396-0899	602-396-0932
Quantum SPC	Intercim (division of Effective Management Systems, Inc.)	800-445-7785 612-894-9010	612-894-0399

Figure F.11. - Producibility Software

Product	Company	Telephone	Fax
Quantum SPC	Effective Management Systems, Inc.	800-962-1279 414-359-9800	414-359-9011
RQM (Real-Time Quality Management) (V.7.2.2)	Automated Technology Associates, Inc.	800-473-9012 317-271-9545	317-271-7974
Service Industry Analyst (V.1.1)	Perry Johnson, Inc.	800-800-7852 248-358-3388	248-358-0882
SPC (Statistical Process Control)	BJ Software Systems (division of Thermo Instrument Controls, Inc.)	800-771-3007 281-922-4357	281-922-5109
SPC 9000 (V.3.10)	PowerWay, Inc.	800-964-9004 317-598-1760	317-598-1740
SPC Direct	Stochos, Inc.	800-426-4014 518-372-5426	518-372-4789
SPC Express for Windows	Major Micro Systems, Inc.	248-350-9177	248-350-9274
SPC Workstation II (V.6.0)	Metrscope International, LLC	800-868-7481 803-754-0090	803-786-2110
SPM+Open / Statistical Process Monitoring & Control System (V.7.1.2)	Salemo Manufacturing Systems, Inc.	248-641-0800	248-641-0807
SQC pack for Windows	Productivity-Quality Systems, Inc.	800-777-3020 937-885-2255	937-885-2252
Statistical Process Control	Macatawa Computer Services, Inc.	800-400-2430 616-392-6941	---
Statistical Process Control	Sector Systems Company, Inc.	781-639-2625	---
Synergy Maestro (V.4.2)	Zontec, Inc.	800-955-0088 513-648-0088	513-648-9007
TimeSaver Maestro	Zontec, Inc.	800-955-0088 513-648-0088	513-648-9007
TQC Manager	Metrscope International, LLC	800-868-7481 803-754-0090	803-786-2110
TrueCELL	Thedra Technologies, Inc.	248-362-2763	248-362-364
TrueSPC (V.2.0)	Thedra Technologies, Inc.	248-362-2763	248-362-3649
VIEWpoint	SoftPLC Corp.	800-SOFTPLC 281-852-5366	281-852-3869
Simulation			
ADAPTication for Manufacturing (V.6.1)	PowerCerv Corp.	813-226-2600	813-222-0886
ADVENT	Aspen Technology, Inc.	617-577-0100	617-577-0303
Algor Finite Element Analysis and Event Simulation	Algor, Inc.	800-482-5467 412-967-2700	412-967-2781
ANVIL EXPRESS	Manufacturing and Consulting Services, Inc.	800-932-9329 602-991-8700	602-991-8732
Arena (V.2.0)	Systems Modeling Corp.	412-741-3727	412-741-5635
ASSEMBLY Option / Deneb	Deneb Robotics, Inc.	248-377-6900	248-377-8125
Automation Master	HEI Corp.	630-665-5500	630-665-5769
AutoMod (V.8.5)	AutoSimulations, Inc.	801-298-1398	801-298-8186
AutoPro (Rel.14)	Intercim (division of Effective Management Systems, Inc.)	800-445-7785 612-894-9010	612-894-0399
AutoStat	AutoSimulations, Inc.	801-298-1398	801-298-8186
AutoView	AutoSimulations, Inc.	801-298-1398	801-298-8186
Baan IV	Baan Co.	800-644-4634 650-462-4949	650-462-4961
Board Station	Mentor Graphics Corp.	800-592-2210 503-685-7000	503-685-1274
Bottomline-V Corporate Financial Planning and Valuation System for DOS/Windows (V.6.1)	ILAR Systems, Inc.	800-777-4920 714-640-2985	714-640-7233
CA-KBM: Standard Product Cost	Computer Associates International, Inc. (Acacia Technologies Business Unit)	800-523-5260	800-201-1782
CA-PRMS Capacity Requirements Planning	Computer Associates International, Inc. (Acacia Technologies Business Unit)	800-523-5260	800-201-1782
CA-PRMS Distribution Requirements Planning	Computer Associates International, Inc. (Acacia Technologies Business Unit)	800-523-5260	800-201-1782
CA-PRMS Forecasting Workbench	Computer Associates International, Inc. (Acacia Technologies Business Unit)	800-523-5260	800-201-1782
CA-PRMS Product Structure	Computer Associates International, Inc. (Acacia Technologies Business Unit)	800-523-5260	800-201-1782
CAM-POST (V.10.5)	ICAM Technologies Corp.	800-827-ICAM 514-697-8033	514-697-8621
CIMpro (V.5.1)	Intercim (division of Effective Management Systems, Inc.)	800-445-7785 612-894-9010	612-894-0399
CimStation Inspection	SILMA, Inc. (division of Adept Technology, Inc.)	800-34-SILMA 408-432-1260	408-432-3490

Figure F.11. - Producibility Software (continued)

Product	Company	Telephone	Fax
Collaborative Production Management	Numetrix, Ltd.	800-555-2173 416-979-7700	416-979-7559
Control (Rel.7.3)	Cincom Systems, Inc.	800-543-3010 513-662-2300	513-481-8332
C-MOLD (V.97.7)	C-MOLD	502-423-4350	502-423-4369
CMS (Capacity Management System)	Manufacturing Resource Management	800-745-4101 508-655-4100	508-655-3000
DFM Workbench (V.1.0)	Avant! Corp.	510-413-8000	510-413-8080
DTRO Forecasting	DTRO, Inc. (an IBM Co.)	415-661-3904	---
dVISE (V.5.0)	Division Inc. (subsidiary of Division Group PLC)	800-877-8759 650-312-8200	650-312-8300
DynaPLUS	Aspen Technology, Inc.	617-577-0100	617-577-0303
EDA Bridge (V.7.0)	OrCAD, Inc.	503-671-9500	503-671-9501
EdgeCAM (V.3.0)	Pathtrace Systems, Inc.	909-937-1222	909-937-1229
EnRoute (V.2.0)	ScanVec, Inc. (subsidiary of ScanVec Co., Ltd.)	800-866-6227 978-694-9488	978-694-9482
ENVISION (V.4.0)	Deneb Robotics, Inc.	248-377-6900	248-377-8125
ESPRIT/C (V.9.0)	DP Technology Corp.	805-388-6000	805-388-3085
ESPRIT/X (V.10)	DP Technology Corp.	805-388-6000	805-388-3085
Extend + Manufacturing (V.4.0)	Imagine That, Inc.	408-365-0305	408-629-1251
EUCLID Analyst	Matra Datavision, Inc. (subsidiary of Lagardere Groupe)	800-854-5429 978-685-5511	978-685-7100
EUCLID Machinist	Matra Datavision, Inc. (subsidiary of Lagardere Groupe)	800-854-5429 978-685-5511	978-685-7100
Factor / AIM (7.0)	Pritsker Corp.	800-428-7636 317-879-1011	317-471-6525
Fastflo	Numerical Algorithms Group, Inc.	630-971-2337	630-971-2706
Finite Capacity Planning	Distinction Software, Inc.	770-390-9339	770-390-9757
GELLO (V.3.4)	Event Technologies, Inc.	414-427-8002	414-427-8034
GPSS/H Professional (Rel.3.0)	Wolverine Software Corp.	800-456-5671 703-750-3910	703-642-9634
GPSS (General Purpose Simulation System)	Simulation Software, Ltd.	519-657-8229	519-657-6516
GRAFX II (V.1.13)	Datacut, Inc.	800-882-2288 914-693-6000	914-693-6738
G2 (V.5.0)	Gensym Corp.	617-547-2500	617-547-1962
I-DEAS Master Series (V.5.0)	Structural Dynamics Research Corp. (SDRC)	513-576-2400	513-576-2135
I-DEAS Material Data System	Structural Dynamics Research Corp. (SDRC)	513-576-2400	513-576-2135
I-DEAS Mold Cooling	Structural Dynamics Research Corp. (SDRC)	513-576-2400	513-576-2135
I-DEAS Mold Filling	Structural Dynamics Research Corp. (SDRC)	513-576-2400	513-576-2135
I-DEAS Thermoset Molding	Structural Dynamics Research Corp. (SDRC)	513-576-2400	513-576-2135
ISaGRAF Workbench (V.3.20)	TranSys, Inc.	800-440-1131 602-926-4100	602-926-6622
Jake / Jake-UX	JAI, Inc.	888-516-5253 909-637-1073	909-637-1084
JBA System 21 Capacity Planning	JBA International, Ltd.	800-522-4685 847-590-0299	847-590-0394
JBA System 21 Vendor Scheduling	JBA International, Ltd.	800-522-4685 847-590-0299	847-590-0394
J.D. Edwards Capacity Requirements Planning	J.D. Edwards World Solutions Co.	800-727-5333 303-488-4000	303-334-4880
KINEMA / SIM	Animation Science	617-497-0410	617-497-4011
Management Simulator	Dynacomp, Inc.	716-346-9788	---
ManSim / X (V.3.10)	Tyecin Systems Inc.	650-949-8501	650-949-8505
MARC / AutoForge	MARC Analysis Research Corp.	800-548-4665 650-329-6800	650-323-5892
Mast (V.5.1)	CMS Research, Inc.	920-235-3356	920-235-3816
MatPlan: Inventory Forecasting & Planning System	Micro Management Systems	414-427-8538	414-427-8539
MAX for Windows (V.3.0)	Micro-MRP, Inc. (subsidiary of Kewill Systems, PLC)	800-338-6921 650-345-6000	650-345-3079
Maxwell EM 2D Field Simulator (V.6.4)	Ansoft Corp.	412-261-3200	412-471-9427
MetalMan (V.2.0)	Metalman Corp.	800-346-5287 505-242-4995	505-247-0208
Micro Saint (V.2.0)	Micro Analysis & Design, Inc.	303-442-6947	303-442-8274
MK Fixed Asset Registration	Computer Associates International, Inc. (MK Group Business Unit)	800-407-8686 407-661-6985	407-660-8853
MK Master Production Scheduling	Computer Associates International, Inc. (MK Group Business Unit)	800-407-8686 407-661-6985	407-660-8853
MPSwin	Bridgeware, Inc.	510-782-7526	510-782-7607
MSC / PATRAN (V.7.5)	The MacNeal-Schwendler Corp.	800-336-4858 213-258-9111	213-259-3838

Figure F.11. - Producibility Software (continued)

Product	Company	Telephone	Fax
MS/X Planner (V.3.10)	Tyecin Systems Inc.	650-949-8501	650-949-8505
NCSIMUL	Matra Datavision, Inc. (subsidiary of Lagardere Groupe)	800-854-5429 978-685-5511	978-685-7100
Nonlinear Control Design Blockset	The MathWorks, Inc.	508-647-7000	508-647-7001
Nuform Level II	A. S. Thomas, Inc.	781-329-9200	781-461-8431
Oracle Capacity (Rel.9.0)	Oracle Corp.	800-633-0596 650-506-7000	650-506-7200
Oracle Inventory (Rel.9.0)	Oracle Corp.	800-633-0596 650-506-7000	650-506-7200
PaceMaker-RDS	Paragon Management Systems, Inc.	310-338-8444	310-338-9878
PCB Thermal	Pacific Numerix Corp.	602-483-6800	602-483-8526
PDME (Plant Data Management Environment)	Intergraph Corp.	800-345-4856 205-730-2000	205-730-8300
Personal Machinist (V.6.0)	Computervision Corp.	800-248-7728 781-275-1800	781-275-2670
Plant CONCEPT	EA Systems Inc.	800-657-2723 510-748-4700	510-748-4714
Prelude MANUFACTURING	Matra Datavision, Inc. (subsidiary of Lagardere Groupe)	800-854-5429 978-685-5511	978-685-7100
Prelude MANUFACTURING for Windows	Matra Datavision, Inc. (subsidiary of Lagardere Groupe)	800-854-5429 978-685-5511	978-685-7100
Pro-III Master	Access International Group	973-360-0750	973-360-0710
ProMIRA for Windows NT (V.4.0)	ProMIRA Software Inc.	800-380-1290 613-596-3344	613-596-2422
ProModel (V.3.5)	PROMODEL Corp.	801-223-4600	801-226-6046
Pro / NC - CHECK	Parametric Technology Corp.	781-398-5000	781-398-6000
Prosults	R.D. Byrnes Co.	414-276-1850	---
PROVISA (V.6.0)	Lanner Group Ltd.	440-519-1200	440-519-1243
Purchase Planning	Distinction Software, Inc.	770-390-9339	770-390-9757
QMS Programs/Data Entry Module	John A. Keane & Associates, Inc.	609-924-7904	609-924-1078
QueGauss	Aptech Systems, Inc.	425-432-7855	425-432-7832
QUEST (V.3.0)	Deneb Robotics, Inc.	248-377-6900	248-377-8125
Queueing+Analysis Software (V.1.0)	Lucent Technologies, Inc. (Software Solutions Group)	800-462-8146 407-662-7254	---
QuickTeach	ABB Flexible Automation Inc.	414-785-3400	414-785-0342
ROBCAD	Tecnomatix Technologies, Inc. (subsidiary of Tecnomatix Technologies, Ltd.)	800-ROBCAD1 248-471-6140	248-471-6147
ROBCAD/Man	Tecnomatix Technologies, Inc. (subsidiary of Tecnomatix Technologies, Ltd.)	800-ROBCAD1 248-471-6140	248-471-6147
ROBCAD/Paint	Tecnomatix Technologies, Inc. (subsidiary of Tecnomatix Technologies, Ltd.)	800-ROBCAD1 248-471-6140	248-471-6147
ROBCAD/Spot	Tecnomatix Technologies, Inc. (subsidiary of Tecnomatix Technologies, Ltd.)	800-ROBCAD1 248-471-6140	248-471-6147
RSTune	Rockwell Software Inc.	800-223-5354 414-321-8000	414-321-2211
SDLT (Synchronized Dynamic Lead Time)	Manufacturing Management Associates, Inc.	800-574-0308 630-574-0300	630-574-0309
SIMAN / Cinema V	Systems Modeling Corp.	412-741-3727	412-741-5635
SIMPROCESS (V.2.1)	CACI Products Co. (subsidiary of CACI International, Inc.)	619-824-5200	619-457-1184
SLX (V.1.0) (Statistical Output) Proof Animation (V.3.3) (Graphical Output)	Wolverine Software Corp.	800-456-5671 703-750-3910	703-642-9634
Soft Machines	SILMA, Inc. (division of Adept Technology, Inc.)	800-34-SILMA 408-432-1260	408-432-3490
ST-POINT (V.2.11)	Scheduling Technology Group	972-720-1000	972-720-1001
Supply Chain Management Manufacturing Resource Planning (V.3.03)	American Software, Inc.	800-SCM-2-WIN 404-261-4381	404-264-5206
SynQuest Optimized Planning	SynQuest, Inc.	800-844-3228 770-447-8667	770-447-4995
Taylor II for Windows (V.4.2)	F&H Simulations, Inc.	801-224-6914	801-224-6984
The Complete Works with Piece Works	The Edge, Inc.	800-917-2217 803-432-7674	803-425-5064
Total Enterprise Activity Management (T.E.A.M.)	Hanford Bay Associates, Ltd.	716-636-0100	716-636-1458
TS/X Planner (V.3.10)	Tyecin Systems Inc.	650-949-8501	650-949-8505
UG / Mechanisms	EDS Unigraphics (division of Electronic Data Systems Corp.)	314-344-5900	314-344-5158
UG / Sheet Metal Design	EDS Unigraphics (division of Electronic Data Systems Corp.)	314-344-5900	314-344-5158
UG / Simulation	EDS Unigraphics (division of Electronic Data Systems Corp.)	314-344-5900	314-344-5158
UG / Unisim	EDS Unigraphics (division of Electronic Data Systems Corp.)	314-344-5900	314-344-5158
UltraArc (V.4.0)	Deneb Robotics, Inc.	248-377-6900	248-377-8125
UltraSpot (V.4.0)	Deneb Robotics, Inc.	248-377-6900	248-377-8125
Unigraphics	EDS Unigraphics (division of Electronic Data Systems Corp.)	314-344-5900	314-344-5158

Figure F.11. - Producibility Software (continued)

Product	Company	Telephone	Fax
VALISYS / Assembly	Tecnomatix Technologies, Inc. (subsidiary of Tecnomatix Technologies, Ltd.)	800-ROBCAD1 248-471-6140	248-471-6147
VERICUT (V.3.4)	CGTech	714-753-1050	714-753-1053
VIC-3D (V.2.4)	Sabbagh Associates, Inc.	812-339-8273	812-339-8292
ViewSpice	Synopsys, Inc.	650-962-5000	650-965-8637
Virtual Collaborative Engineering (VCE)	Deneb Robotics, Inc.	248-377-6900	248-377-8125
Virtual NC (V.3.0)	Deneb Robotics, Inc.	248-377-6900	248-377-8125
Vision 4000 (V.4.3)	Northern Computer Systems, Inc.	800-387-1177 705-746-5873	705-746-5178
WebPLAN	Enterprise Planning Systems Corp. (subsidiary of Enterprise Planning Systems),	630-510-3258	630-510-3181
WebPLAN SERVICE	Enterprise Planning Systems Corp. (subsidiary of Enterprise Planning Systems),	630-510-3258	630-510-3181
Witness (Rel.8.0)	Lanner Group Ltd.	440-519-1200	---
Analytix (V.3.2)	Saltire Software	800-659-1874 503-968-6251	503-520-6998
CADDS 5 (Rel.7.0)	Computervision Corp.	800-248-7728 781-275-1800	781-275-2670
Entry Level StandbyServer for NetWare	Vinca Corp.	800-934-9530 801-223-3100	801-223-3107
I-DEAS Artisan Series Modeler	Structural Dynamics Research Corp. (SDRC)	513-576-2400	513-576-2135
I-DEAS Tolerance Analysis	Structural Dynamics Research Corp. (SDRC)	513-576-2400	513-576-2135
Mechanical Advantage II (V.4.3)	Cognition Corp.	800-669-7935 781-271-9300	781-271-0813
SoftFit (V.4.0)	Origin International, Inc.	800-269-2509 905-821-1820	905-821-0216
SolidWorks 97 Plus	SolidWorks Corp.	800-693-9000 978-371-2910	978-371-5088
StackSoft Stacked Tolerance Analysis	Dynacomp, Inc.	716-346-9788	---
TITANIUM	Micro Data Base Systems, Inc. (MDBS)	800-445-MDBS 765-463-7200	765-463-1234
TI/TOL Six Sigma Tolerance Optimization System (TI/TOL Six Sigma is a trademark of Raytheon Systems Company)	Raytheon Systems Company	1-800-232-3200	1-972-344-5797
Tolculator (V.4.0)	International Geometric Tolerancing Institute, Inc.	408-251-7058	408-272-2327
VALISYS/Analyze	Tecnomatix Technologies, Inc. (subsidiary of Tecnomatix Technologies, Ltd.)	248-471-6147	---
Variation Systems Analysis	Engineering Animation, Inc.	248-455-0000	248-455-0000
ADAPTlication for Manufacturing (V.6.1)	PowerCerv Corp.	813-226-2600	813-222-0886
BDS (Bayesian Decision Support System) (V.2.0)	OPA, Inc. - The Integrated Risk Management Group	707-762-2227	---
CETol	Raytheon Systems Company	972-344-5750 972-344-5770	---
DATA (V.3.0)	TreeAge Software, Inc.	800-254-1911 413-458-0104	413-458-0105
Decision Plus	Nicesoft Corp.	512-331-9027	512-219-5837
DPL (V.3.2)	Applied Decision Analysis	888-926-9251 650-926-9251	650-854-6233
ISOxPERT (V.4.0)	Management Software International, Inc.	800-ISO-EASY 781-279-1919	781-279-2929
Logiscope	Verilog, Inc.	800-424-3095 972-241-6595	972-241-6594
MFG/EDP Quality Control System II	MFG/EDP, Inc.	305-292-1254	305-294-4230
Manufacturing Management Plan Outline and Assignment Workbook	Pioneer Manufacturing, Inc.	520-714-1681	520-714-1422
Neural Network Utility (V.3.0)	IBM (International Business Machines)	800-426-3333 914-765-1900	---
Perception: PERT-PAC	SPAR Associates, Inc.	410-263-8593	410-267-0503
Powersim Solver (V.1.0)	Powersim Corp.	703-481-1270	703-481-1271
PQMPlus (Productivity Quality Measurement System) (Rel.2.1)	Union Pacific Technologies (subsidiary of Union Pacific Corp.)	800-776-0679 314-768-7422	314-768-0927
Producibility Program Plan Outline	Pioneer Manufacturing, Inc.	520-714-1681	520-714-1422
Producibility Risk Assessment Worksheet	Pioneer Manufacturing, Inc.	520-714-1681	520-714-1422
QFD	Raytheon Missile Systems Company	520-RX4-2000	520-794-9898
QFD Scope (V.1.1)	Integrated Quality Dynamics, Inc.	800-870-4200 310-540-6142	310-540-6392
RiskTech	NorthPoint Software Ventures, Inc.	508-370-4212	508-370-4216

Figure F.11. - Producibility Software (continued)

Product	Company	Telephone	Fax
SES / Workbench (V.3.0)	Scientific and Engineering Software, Inc. (SES)	800-759-6333 512-328-5544	512-327-6646
SLIM (Software Lifecycle Management) (V.4.0)	QSM Associates, Inc.	413-499-0988	413-447-7322
SmartCost (V.4.0)	Knowledge Based Systems, Inc.	409-260-5274	419-268-2310
SPC KISS 97	Air Academy Associates, LLC	800-748-1277 719-531-0777	719-531-0778
TechKnowledgey	NorthPoint Software Ventures, Inc.	508-370-4212	508-370-4216
Thermal (V.3.1)	SEA (Systems Effectiveness Associates, Inc.)	800-688-2003 781-762-9252	781-769-9422
XTie-RT (Cross Tie Requirements Tracer)	Teledyne Brown Engineering (subsidiary of Allegheny Teledyne Inc.)	800-933-2091 205-726-1000	205-726-1033
Y2K Manager	Janus Technologies, Inc.	412-787-3030	412-787-3099

Figure F.11. - Producibility Software (continued)