



Bureau of Marine Resources  
Ministry of Natural Resources, Environment and Tourism  
Republic of Palau

---

# ANNUAL REPORT

## 2017

---





---

# ANNUAL REPORT 2017

---

Bureau of Marine Resources  
Ministry of Natural Resources, Environment and Tourism  
Republic of Palau



*Koror, Palau  
March 2019*



---

COPYRIGHT

---

Bureau of Marine Resources  
Ministry of Natural Resources, Environment & Tourism  
Republic of Palau  
2019

---

CITATION

---

BMR (2018) Republic of Palau Bureau of Marine Resources Annual Report 2017. Bureau of Marine Resources, Koror, Palau.

---

PREPARED BY

---

Bureau of Marine Resources, Ministry of Natural Resources, Environment & Tourism,  
Government of the Republic of Palau

---

AVAILABLE FROM

---

Bureau of Marine Resources  
Ministry of Natural Resources, Environment & Tourism  
P.O. Box 359, Koror, Republic of Palau PW 96940  
Tel.: (680) 488-3125/2897  
Fax: (680) 488-3555  
E-mail: [tekoilchei@palaunet.com](mailto:tekoilchei@palaunet.com)

## MESSAGE FROM THE MINISTER

---



The last annual report on Palau's fisheries and marine resources was published some twenty-five years ago by the Marine Resources Division under what was then the Ministry of Resources and Development. This report describes the current structure and functions of the Bureau of Marine Resources (BMR) and reviews its operations in the year 2017. It summarizes annual trends in marine product exports, progress in fisheries and aquaculture development, and information on our offshore fisheries. It also provides an overview of the various permit procedures overseen by BMR, and the main challenges faced over the past year.

As Palau continues to build its management capacity to fully implement the Palau National Marine Sanctuary (PNMS) by 2020, it is important for us to prioritize the allocation of our resources and foster existing relationships with partners to support our efforts.

Domesticating our offshore fisheries requires some work that is already taking place, such as the implementation of the Strategic Plan for Tuna Fisheries 2017-2021 and continued trials of our Electronic Monitoring Program. It also requires new partnerships from countries and organizations that are able to provide the necessary expertise in the areas of monitoring, enforcement, and financing.

Likewise, resources will need to be directed towards understanding and mitigating immediate and future threats to our coastal fisheries. The development of a Strategic Plan for our Nationwide Network of Anchored Fish Aggregating Devices (FADs) and improvements to the management of data related to reef fisheries production and exports are impending steps towards ensuring the protection of food security and livelihoods for our communities.

This publication marks the re-installment of BMR's annually recurring reports. I encourage readers to provide feedback on how the report can be improved in coming years to ensure that the information on BMR's activities and performance is relevant and accessible to as wide an audience as possible. Ultimately, our goal is to encourage community stewardship and facilitate collaboration among stakeholders to protect the sustainability of our marine resources for current and future generations.

A handwritten signature in blue ink, appearing to read 'F. Umiich Sengebau', with a long horizontal flourish extending to the right.

F. Umiich Sengebau

Minister

Ministry of Natural Resources, Environment and Tourism

## FOREWORD FROM THE DIRECTOR

---



I am pleased to present to the Government and people of Palau the first annual report produced by the Bureau of Marine Resources (BMR) since 1992. This report therefore signifies a milestone achievement. It has been prepared in accordance with the Bureau's mandate as described in Executive Order No. 381, which requires BMR to analyze and report on the status of marine resources and aquaculture.

The main objective of this report is to communicate BMR's activities to government, our partners in non-government organizations, all those working in the fisheries and conservation sectors, and, last but not least, the general public. As such, we have strived to write in a reader-friendly and engaging manner, avoiding highly technical terms and analyses. To be able to serve our audience better, we welcome comments on the usefulness of the information presented for future annual reports.

The single most challenging constraint that the Bureau has been in deadlock over throughout the years is the lingering and debilitating lack of expertise in our technical positions. We can all agree that it was the absence of financial attention to support these positions that created stagnancy and the slow development of the BMR into the institution that it ought to be. It took two decades for improvement to achieve any foot hold and what we can see in this Annual Report is the result of the work accomplished by the Bureau's generally home-grown or locally produced officers and technicians, employing knowledge and ability gained through practical experience and augmented by periodic training made available through our development partners, like the Pacific Community (SPC), the Food and Agriculture Organization of the United Nations (FAO), The Nature Conservancy (TNC) and the Japanese and Taiwanese Governments.

Unlike the Palau International Coral Reef Center (PICRC), I tend to consider the BMR as no longer a scientific authority on the marine resources of the Republic but rather as the management or regulatory authority in this area's management jurisdiction, and I believe it could not be more appropriate than that.

As such, I believe it is the main duty of the Bureau to recommend legislation or draft regulations for the conservation or the protection of the country's vulnerable or threatened marine life. I am very pleased that the Republic has progressed and evolved to the point today where preserving our marine resources is 'everyone's business.' You can just look at the many

groups, NGOs, and lawmakers putting forth their own draft measures and proposed legislations without any initiation from the Bureau or the Ministry of Natural Resources, Environment, and Tourism.

It looks like we have many people caring for the environment and our natural resources but as Mr. Noah Idechong, the former Chief of the Division of Marine Resources and Chairman of the PICRC Board, stated in his address to the Senate Chamber recently: “We are done determining what needs to be done regarding our environment. What we need to do now is to strengthen the application of the law as in enforcement, by supporting and enabling the relevant agencies to do their job effectively” (English translation).

The most apparent trend that should be recognized by all from here on in is that our very finite marine resources have been in great decline and in some cases, drastically diminished. To the members of the National Congress who have the power to save our resources, I say, please act expeditiously to conserve and to protect the most threatened – or we will be known in Palau history as the generation that had so many chances but did nothing while we approached and passed the point of no return.

Of course, I didn’t need to hear the comments from the great Chairman of the PICRC Board to start thinking as he does. This has always been my opinion ever since I started to work at the BMR as the Administrative Officer more than a decade and a half ago.

Thank you to the caring fishermen and NGOs! Thank you to the States of Ngarchelong and Kayangel for creating the Northern Reef fisheries management measures. And thank you to the forward-looking OEK for passing the high-end tourism legislation. The less mass tourism, the less protected fish, clams, lobsters, black coral, sea cucumbers, etc. are taken from the sea.

We look forward to receiving suggestions for improvement, comments and queries.

A handwritten signature in blue ink, appearing to read 'LR', with a long, sweeping underline that extends to the right.

Leon Remengesau  
Director  
Bureau of Marine Resources



## ACKNOWLEDGEMENTS

---

The Bureau of Marine Resources acknowledges the generous support of our local and regional partners in the preparation and publication of this report.

The Nature Conservancy (TNC) Palau, especially Mr. Steven Victor for fruitful collaborations over the years; Mrs. Yvonne Ueda for assistance with the drafting of this report as part of her support to BMR; and Ms. Rachel Cohn, a TNC intern, for proof-reading the draft report.

Staff at the Pacific Community's Coastal Fisheries Programme (SPC-CFP) within the Fisheries, Aquaculture and Marine Ecosystems (FAME) Division, especially Mr. Ian Bertram, Mr. Jason Raubani and Dr. Andrew Halford for hosting Dr. Vanessa Jaiteh and Mrs. Yvonne Ueda at SPC in February 2018 and for providing guidance and resources for them as they developed this report.

Funding support for the development of this Annual Report was provided by the Palau National Marine Sanctuary Office (PNMSO) and SPC. The generous assistance of SPC in formatting and printing this report is sincerely appreciated and acknowledged.



# TABLE OF CONTENTS

---

Message from the Minister.....	iii
Foreword from the Director .....	v
Acknowledgements.....	vii
List of Figures.....	xii
List of Tables.....	xii
List of Acronyms.....	xiv
Background.....	1
Palau’s fisheries .....	1
Artisanal fishery .....	2
Commercial fishery .....	2
Inshore.....	2
Offshore.....	2
Purpose of the annual report .....	4
The Bureau of Marine Resources.....	4
Mandate .....	4
Mission.....	4
Corporate Structure .....	5
Organization.....	5
Finance.....	7
Operating budget and expenditure .....	7
Donor funding and projects in 2017.....	7
Revenue.....	9
Inshore.....	9
Offshore.....	9
Assets and Facilities.....	9
Activities.....	10
Administration.....	10
Permitting.....	10
Division of Coastal Fisheries Management .....	13
Overview.....	13

<b>Data Collection.....</b>	<b>13</b>
Marine Export Declarations (MEDs).....	13
Commercial exports.....	16
Personal exports .....	18
Scientific exports.....	20
<b>Fish Market Data.....</b>	<b>21</b>
<b>Annual Sports Fishing Tournament - Etpison Cup.....</b>	<b>22</b>
<b>Threatened, Endangered and Protected (TEP) Species .....</b>	<b>23</b>
CITES permits issued.....	23
Giant clam exports .....	23
Nautilus exports.....	25
Hard corals.....	25
Airport Confiscations .....	27
<b>Challenges and Opportunities.....</b>	<b>29</b>
Export data.....	29
<b>Division of Fisheries Development &amp; Aquaculture .....</b>	<b>31</b>
<b>Overview .....</b>	<b>31</b>
<b>Fisheries Development.....</b>	<b>31</b>
FADs.....	31
Overseas Fishery Cooperation Foundation (OFCF) of Japan.....	33
<b>Aquaculture Development.....</b>	<b>34</b>
<b>Giant Clam Mariculture.....</b>	<b>35</b>
Production.....	35
Farm promotion and construction.....	36
Seedling Distribution to Farms.....	38
Wild stock enhancement.....	40
Giant Clam Farm Monitoring (Collaboration with PALARIS) .....	41
<b>Fin Fish Culture.....</b>	<b>41</b>
Rabbitfish Floating Fish Cage/Fish Pen Construction.....	42
Donor Funding and Projects.....	43
<b>Challenges and Opportunities.....</b>	<b>44</b>
Aquaculture.....	44
Fisheries Development/FADS.....	44

Division of Oceanic Fishery Management.....	46
Roles and responsibilities .....	46
Fleet structure.....	46
Fishing permits.....	47
Longline and Purse-seine catch.....	47
Domestic sales and donations.....	49
Data Collection Systems .....	51
Log sheets & Port Sampling - data collection and verification.....	51
Observer data.....	51
Transshipment.....	52
Monitoring & Control.....	52
Vessel Monitoring Systems (VMS) & Automatic Location Communicator (ALC).....	52
Electronic Monitoring (EM) & Reporting (ER).....	53
Compliance.....	56
Enforcement .....	57
Regional and international instruments.....	57
Palau National Marine Sanctuary .....	58
Challenges and Opportunities.....	61
Division of Information and Data Management .....	62
Fisheries regulations and policy .....	62
Technical Reports and Publications by BMR 2014- 2017 .....	64
Challenges and Opportunities.....	64
Constraints of the Bureau .....	65
Examples of projects undertaken in 2017 by partner organizations in Palau.....	68
Improving marine resources management in Palau through ecosystem-based fisheries management: fisheries-dependent monitoring of commercial reef fisheries .....	68
FAO Assistance for the establishment of the Micronesian Association for Sustainable Aquaculture (MASA) 2014-2017.....	69
Estimating size at maturity using length measurements from spawning aggregations and deriving 20% SPR size limits for at least five reef fish species.....	70
Data and Information referenced in the report .....	72

## LIST OF FIGURES

---

Figure 1. Organizational structure of the Bureau of Marine Resources, Vacant positions are marked with an asterisk.....	5
Figure 2. MEDs issued by month in 2017.....	14
Figure 3. MED forms for scientific research, by country of destination for 2017.....	21
Figure 4. CITES permits issued by country in 2017. ....	24
Figure 5. Example of airport confiscation. Procedure includes cataloguing and weighing the confiscated items.....	28
Figure 6. FAD deployments for the period 2013 to 2017. No monitoring has been conducted since 2013; as such, presence or absence of the FADs could not be verified. ....	33
Figure 7. Workers outside the Palau National Aquaculture Center.....	42
Figure 8. Floating fish cage (above) and fish pen (below).....	43
Figure 9. Vessels in Palau’s EEZ monitored using VMS (left) and VMS and AIS (right). Orange teardrops represent vessels monitored by the FFA VMS, yellow triangles signal buoys used by longline vessels. All other triangles represent vessels transmitting AIS.....	54
Figure 10. A representative (left) of a locally-based fishing company translates reporting requirements as explained by fisheries officers from the Division of Oceanic Fisheries Management.....	58

## LIST OF TABLES

---

Table 1. Approved appropriation budgets and total expenditures for BMR, 2010-2017.....	7
Table 2. Major grants and funding support to BMR over the recent past. ....	8
Table 3. Permit types (not including permits administered by the Division of Oceanic Fishery Management).....	10
Table 4. Research permits applied for in 2017. ....	11
Table 5. Marine Export Declarations recorded by BMR for 2017. ....	15
Table 6. Destination countries for commercial exports. MEDs = Marine Export Declarations. Countries in the “Other” category include mainland USA, England, Japan, and Singapore..	17
Table 7. Estimated commercial exports of coastal products from Palau in 2017.....	17
Table 8. Estimated exports of coastal products for personal purposes from Palau in 2017....	18
Table 9. Estimated exports of coastal products (other than reef fish) for personal purposes from Palau in 2017. ....	19
Table 10. Official data for the 2017 Etipison Cup. Fishers may participate in one or more categories (e.g. Trolling and GT Catch and Release).....	22

Table 11. The number of giant clams exported for commercial, personal, and scientific purposes in 2017. Note that half clam shells are sometimes exported and represented as such. ....	24
Table 12. Detail of the number of giant clams exported live or in parts. ....	25
Table 13. Hard coral exports from Palau in 2017. ....	26
Table 14. Summary of Giant Clam Seed Production (2013-2017). Average* is the average number of seeds by species produced for years when seeds were produced.....	35
Table 15. PMDC giant clam stock (as of December 15, 2017). ....	36
Table 16. Summary of giant clam farms constructed over the period 2013-2017 in Palau.....	36
Table 17. Giant clam farm construction details in 2017. ....	37
Table 18. Giant clam seedlings charges, effective June 25, 2014. ....	38
Table 19. Summary of Giant Clam Seed Distribution (2013-2017).....	38
Table 20. Giant Clam Seed Distribution by Species and State in 2017.....	40
Table 21. Summary of Provision of Giant Clams to Conservation Programs (2013-2017)....	40
Table 22. Rabbit fish ( <i>Siganus lineatus</i> /Klsebuul) fry production and distribution in 2017. .	41
Table 23. Number of licenses issued by gear and flagged vessel in 2017. JP = Japan, PW = Palau, TW = Taiwan Republic of China. ....	47
Table 24. Breakdown of catches reported by Palau to the WCPFC, by the domestic (national and chartered vessels; <i>Flag State</i> ) and foreign fleets ( <i>Coastal State</i> ). Within these categories, catch is reported by fishign gear, flag state and species. FSM = Federated States of Micronesia, JP = Japan, KI = Kiribati, PNG = Papua New Guinea, TW = Taiwan.....	50
Table 25. Palau local sales and donations data 2014-2017 (provisional). ....	49
Table 26. Vessels participating in the EM Program, trip and set statistics as of June 19, 2017. ....	53
Table 27. Equipment and services provided to Palau for the EM project.....	55
Table 28. A summary of national fisheries policies since 1994. ....	62
Table 29. Participation of BMR staff in workshops, meetings and trainings in 2017.....	67

## LIST OF ACRONYMS

---

AIS	Automated Information System
ALC	Automatic Location Communicator
BMR	Bureau of Marine Resources
CMM	Conservation and Management Measure
EAF	Ecosystem Approach to Fisheries
EQPB	Environmental Quality Protection Board
FAD	Fish Aggregating Device
FAME	Fisheries, Aquaculture and Marine Ecosystems Division at SPC
FAO	UN Food and Agriculture Organization
FFA	Forum Fisheries Agency
GOP	Government of Palau
NGOs	Non-government organizations
OEK	Olbiil Era Kelulau (Palau National Congress)
OFCE	Overseas Fishery Cooperation Foundation
PCFAAC	Palau Coastal Fisheries and Aquaculture Advisory Committee
PMDC	Palau Mariculture Demonstration Center
PNA	Parties to the Nauru Agreement
PNAC	Palau National Aquaculture Center
RPPL	Republic of Palau Public Law
SPC	Pacific Community
SPC-CFP	SPC Coastal Fisheries Programme
TNC	The Nature Conservancy
VDS	Vessel Day Scheme (of the PNA)
VMS	Vessel Monitoring System
WCPFC	Western and Central Pacific Fisheries Commission
WCPO	Western and Central Pacific Ocean

## UNITS, CONVERSIONS AND ABBREVIATIONS

Metric units are used throughout this document. Conversions are as follows:

- 1 centimeter (cm) = 0.393 inch
- 1 inch = 2.54 cm
- 1 meter (m) = 3.281 feet
- 1 foot = 0.305 m
- 1 kilogram (kg) = 2.20462 pounds
- 1 pound = 0.453592 kg
- 1 degree Celsius = 33.8 deg. Fahrenheit
- 1 deg. Fahrenheit = -17.22 deg. Celsius

All references to dollars are United States Dollars (USD), the currency of Palau.



## BACKGROUND

---

Palau is an archipelago at the western margin of Micronesia, consisting of nine inhabited islands and more than 500 islets. While Palau's total land area comprises only 458 km<sup>2</sup>, its Exclusive Economic Zone (EEZ) covers an approximate area of 604,289 km<sup>2</sup> and encompasses extensive marine ecosystems, many of which are foundational to the continued health and existence of this island nation. The total coastline stretches for over 1,519 kilometers and is often surrounded by adjoining reef systems (of which about 50% are barrier reefs, 37% are fringing reefs, and 12% are coral atolls<sup>1</sup>). Palau is home to 17,950 people and the vast majority (77%) reside in Koror, the country's urban center. Palau's extraordinary marine seascapes have gained worldwide attention, leading it to become a major tourist destination for marine-based activities. In 2014, the country had 146,865 overseas visitors (2015 Census).

## PALAU'S FISHERIES

---

Palau's fisheries fall into two broad categories: commercial and artisanal/subsistence. A recent report showed that a relatively small number of people (n = 83, or 0.8% of all workers in Palau) were formally employed in Palau's commercial fishing sector; of these, only 17 (20.5% of those surveyed) were Palauan citizens<sup>2</sup>. Despite this relatively low formal employment rate in the commercial fisheries sector, a large number of Palauan citizens are involved in small-scale artisanal fisheries<sup>3</sup>. Furthermore, the majority of households are thought to engage in coastal fishing activities for subsistence or as a pastime; men often fish from boats while women are more commonly engaged in reef gleaning.

---

<sup>1</sup> NOAA (n.d.). The Three Main Types of Coral Reefs are Fringing, Barrier, and Atoll.

<sup>2</sup> California Environmental Associates (2016). Palau Fisheries: 2015 Summary. Prepared for the David and Lucile Packard Foundation.

## ARTISANAL FISHERY

---

The artisanal fishery targets mostly the inshore coral reefs and continues to provide the main source of protein for the majority of Palauan people<sup>1</sup>. The average annual fish consumption in Palau is 34.4 kg per capita, although it can reach as high as 86 kg per capita in some remote areas<sup>2</sup>.

Gears used for artisanal fishing commonly include troll (*etaki*) and drop lines (*kereel*), hand spears (*burch*), spear guns (*balch*), set nets (*kesokes*), and cast nets (*bidekill*). The total production of the artisanal sector in 2014 was estimated at about 1,250 mt<sup>3</sup>.

## COMMERCIAL FISHERY

---

### *Inshore*

---

The inshore commercial fishery mostly targets reef fish. Fishing gear used includes handlines (*kereel*), lure or bait casting (*mengetaki*), spear guns (*balch*), hand spears (*burch*), cast (*bidekill*) and set nets (*kesokes*), as well as electronic aids such as global positioning systems (GPS) and fish finders. Boats in this fishery are generally imported and of fiberglass construction. Most of the catch is processed and either sold locally, exported for commercial purposes, or used for personal consumption. In 2014, it was estimated that the total inshore commercial production was around 865 mt, valued at 3.2 million USD<sup>4</sup>.

---

<sup>1</sup> Ota, Y. (2006) Custom and Fishing: Cultural meaning and Social Relations of Pacific Fishing, Republic of Palau,

Micronesia. PhD, University College of London, England, London.

<sup>2</sup> Gillet, R. and Lightfoot, C. (2002) The Contribution of Fisheries to the economies of the Pacific Island Countries, Asian Development Bank, Manilla, Philippines.

<sup>5</sup> Gillett, R. (2016). Fisheries in the Economies of Pacific Island Countries and Territories. Secretariat of the Pacific Community, Noumea.

<sup>6</sup> Gillet, R. and Lightfoot, C. (2002) The Contribution of Fisheries to the economies of the Pacific Island Countries, Asian Development Bank, Manilla, Philippines.

<sup>4</sup> Gillet, R. and Lightfoot, C. (2002) The Contribution of Fisheries to the economies of the Pacific Island Countries, Asian Development Bank, Manilla, Philippines.

---

## *Offshore*

---

The offshore commercial fishery encompasses pelagic species such as yellowfin, skipjack, bigeye, and albacore tuna, and other tuna-like species. These are mainly targeted by the locally based (Palau-flagged) foreign-operated longline vessels of Taiwan (before 2015, this included some pole- and-line fishing vessels), and the offshore-based longline and purse-seine fishing fleets of Japan. In 2017, the total offshore fishery production was estimated to be 9,349 mt<sup>1</sup>, worth 1.2 million USD in export tax and local sales (excluding revenue from licenses and fishing agreements).

---

<sup>1</sup> Oiterong, Z. and Sisor, K. (2018) Annual Report to the WFPF Commission. Part I: Information on Fisheries, Research, and Statistics. Republic of Palau – 2017.

## PURPOSE OF THE ANNUAL REPORT

---

This report summarizes BMR's structure, mandated roles and responsibilities, and available data up to the end of 2017. It also highlights major challenges and limitations faced by the Bureau and its Divisions. The activities of each Division are presented separately and include a summary of annual export trends, aquaculture production and development, and offshore fisheries landings. The report also provides BMR's annual budget, information on donor funding, and an explanation of permitting procedures coordinated by the Bureau. The publication of this report constitutes part of the Bureau's mandate according to Executive Order No. 381, which requires BMR to analyze and report on the status of marine resources and aquaculture.

## THE BUREAU OF MARINE RESOURCES

---

### MANDATE

---

The Bureau of Marine Resources (BMR), which falls under the Ministry of Natural Resources, Environment and Tourism (MNRET) and was established under RPPL No. 7-43, is responsible for exploring, surveying, developing, managing, and conserving all living and non-living marine resources. The Bureau is further mandated under Executive Order 381 to work in five key areas:

1. Policy, institutional, and regulatory framework for management of marine resources;
2. Management, research, and conservation of marine resources through national management and co-management with States;
3. Development and promotion of sustainable aquaculture opportunities;
4. Development of nearshore fisheries resources; and
5. Collection and analysis of all forms of marine resources and aquaculture data.

## MISSION

---

The BMR, in collaboration with the States and other partners, provides support and a favorable environment for the management and sustainable use of marine resources in Palau's subsistence, commercial, aquaculture, and recreational fisheries sectors, considering the possible effects of climate change and other stressors on the marine environment, for the benefit of the people of Palau.

## CORPORATE STRUCTURE

### ORGANIZATION

---

The Bureau is headed by a Director and has four Divisions, each of which is led by a Chief. The four Divisions are: Division of Coastal Fisheries, Division of Fisheries Development and Aquaculture, Division of Information and Data Management, and Division of Oceanic Fishery Management (Fig. 1). As of the date of publication, several positions are vacant, including the four positions for Chiefs of the Divisions, along with positions within the two sub-sections of the Division of Information and Data Management (*Communication, Advisory & Outreach*, and *Data Management and Reporting*), and others (Fig. 1). The Chief of Division roles are currently filled informally by staff within the respective Divisions, while tasks falling under the Division of Information and Data Management are largely fulfilled by the Administrative Officer and Specialist.

The roles and responsibilities of each Division are summarized in each Division's respective section within this report.

# Ministry of Natural Resources, Environment and Tourism

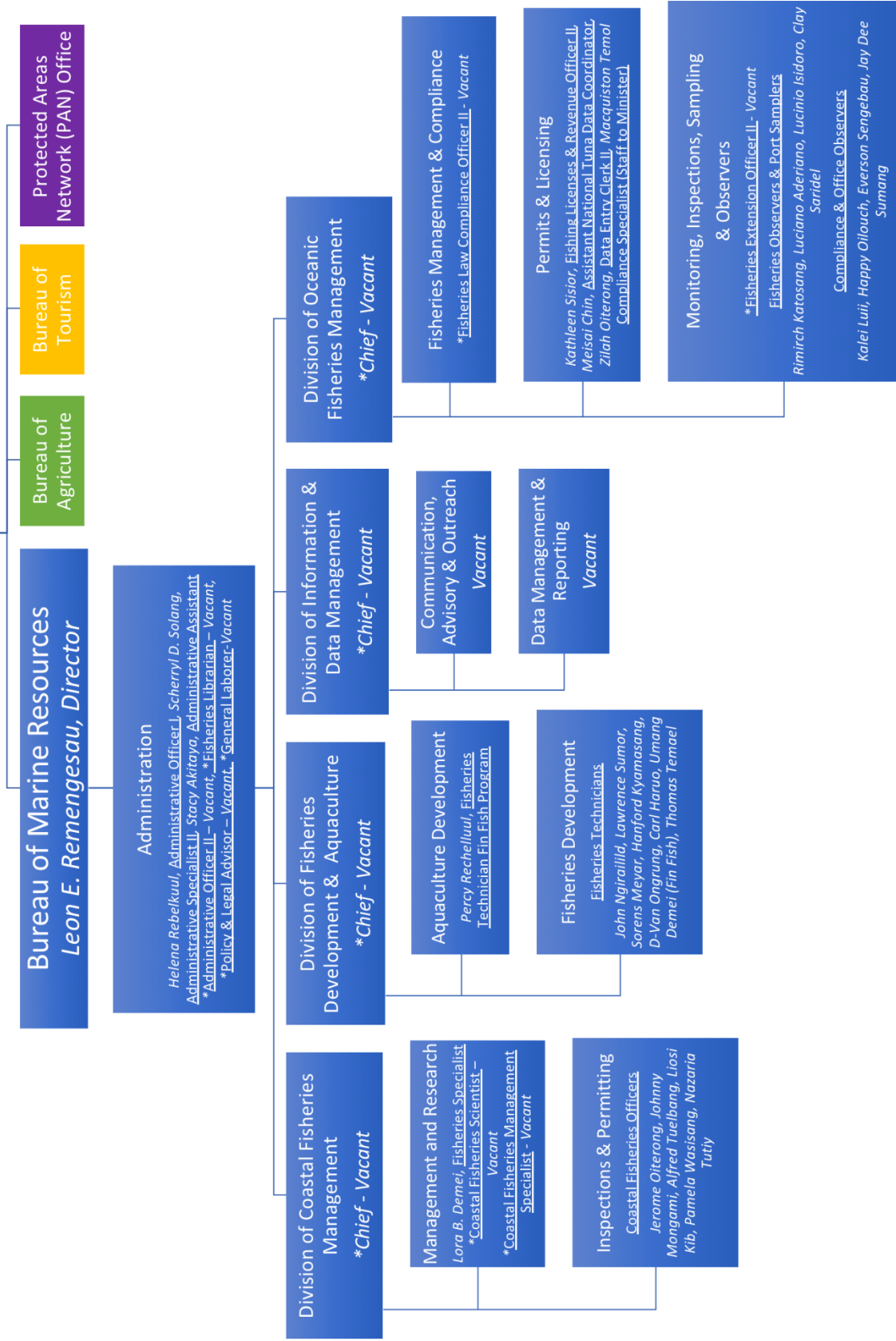

FIGURE 1. ORGANIZATIONAL STRUCTURE OF THE BUREAU OF MARINE RESOURCES, VACANT POSITIONS ARE MARKED WITH AN ASTERISK.

## FINANCE

### OPERATING BUDGET AND EXPENDITURE

---

The approved budget for BMR since 2010 was about 4.3 million USD, with an average annual budget of 534,360 USD (table 1). From 2010 – 2017, BMR expended 99-100% of the government appropriated budget except for the financial year (FY) 2016, when 87% was expended. In 2017, BMR was allocated an approved budget of 575,000 USD. About 43% of this amount was allocated for salaries and the remaining 57% for operations.

TABLE 1. APPROVED APPROPRIATION BUDGETS AND TOTAL EXPENDITURES FOR BMR, 2010-2017.

	Budget (USD)	Total expenditure (USD)
FY2010	461,000	460,992
FY2011	490,670	490,482
FY2012	517,444	513,384
FY2013	509,142	502,845
FY2014	550,205	549,748
FY2015	546,208	538,220
FY2016	625,214	541,472
FY2017	575,000	569,090

### DONOR FUNDING AND PROJECTS IN 2017

---

In addition to the funding allocated to BMR by the government, BMR continues to seek external funding support. The Bureau has received significant financial and technical support from development partners over the past years, some of which will roll into 2018 (table 2).

TABLE 2. MAJOR GRANTS AND FUNDING SUPPORT TO BMR OVER THE RECENT PAST.

Name	Description	Amount	Term
TNC	Grant # BMRPALo8o113 “To improve fishery management through data collection for coastal fishery and provide support for establishing a fishermen’s association”  Amendment - 160 surveys collected using the new survey method, “stereo-video camera.”	\$25,000.00 to \$35,000.00	Start: 8/01/13 End: 7/31/15
	Grant # AP/Micronesia/BMRP12o716 “BMR will coordinate fishery data collection and management at the National Level, support the development of alternative livelihoods, and develop policy recommendations for fishery management. <i>(Support NRFM with Rabbitfish Farms and data management)</i>	\$30,000.00	Start: 12/14/17 End: 06/30/18
	Palau Tuna Management - Design and Implement Long-line VDS * Amendment	\$150,000 to \$200,000	Start: 06/13/15 3 years
OFCF	MOU “The Fisheries Development Assistance for Pacific Island Nations Phase Six (VI)”	\$62,535.00	2016/2017
	MOU (Draft) – “The Fisheries Development Assistance for Pacific Island Nations Phase Six (VI)”	Pending	2017/2018
	MOU “Dispatching Advisor for Sustainable Use of Fishery Resources”	Technical Assistance	One Year Contract
	MOU “Dispatching Aquaculture Expert to provide technical assistance titled: The Technical Cooperation Project for the Promotion of Giant Clam Mariculture”.	Technical Assistance	One Year Contract
FAO	MASA – Micronesian Association for Sustainable Aquaculture	\$499,000	2015/2020
FFA	PDF – Project Development Funding	\$219,889.00	On-going
	Funding MCS Facilitator – <i>(Salary &amp; Housing Allowance)</i>	\$35,495.00	One Year Contract
Taiwan	Dispatch of two Aquaculture Experts (Fin Fish)	\$50,000	One Year Contract
	Establishment of Aquaculture Fund	\$7,764	On-going
	Agriculture and Aquaculture Loan	\$ 5 million	On-going



	Palau National Aquaculture Center (PNAC)	\$700,000	2011
	Repair & Construction of New Building – BMR Hatchery (FinFish)	\$300,000	On-going
JICA	The Project for Renovation of Palau Mariculture Demonstration Center Facility	\$6 million	2017 – 2018

## REVENUE

The annual revenue collected by the Bureau includes export tax for pelagic species (mainly tuna), permits for exports of reef fish and other inshore resources, licensing, registration, and fees for services, as listed below, and the sale of fishing days under the Parties to the Nauru Agreement (PNA) Vessel Day Scheme (VDS).

### *Inshore*

- Giant Clam Seed Sustainability Project Fund – The Bureau collected \$46,772 from its Giant clam development revolving fund for the year 2017.
- Sale of Giant Clam Seedlings – the bureau collected a total of \$3982 in 2017.
- Marine Export Declaration (MED) Fee – The Bureau collected a total of \$32,830 in MED fees in 2017.
- Convention on International Trade in Endangered Species of Wild Fauna and Flora (CITES) Permit Fee – The Bureau collected a total of \$1,860 in CITES Permit fees in 2017.
- Research Permit Fee – The Bureau collected a total of \$8,100 in research fees for 2017.

### *Offshore*

The Bureau's Division of Oceanic Fishery Management, under the PNA Vessel Day Schemes for purse-seine and longline fisheries, collected a total of USD 9.7 million in FY 2017.

## ASSETS AND FACILITIES

The Bureau of Marine Resources' (BMR) main office, constructed in 2011, is located at Malakal and is utilized by all staff, including the Minister and staff of the Bureau of Tourism. The building is equipped with functioning offices, conference room, kitchenettes, and bathrooms.

In addition to BMR’s main office, the Division of Fisheries Development & Aquaculture maintains additional work spaces utilized by the Division’s technical staff – the Palau National Aquaculture Center (PNAC), the original BMR Finfish Hatchery (currently being rebuilt), and a workshop – all located in close proximity to the main office in Malakal.

The Palau Mariculture Demonstration Center (PMDC), the world’s oldest and largest giant clam hatchery and an integral part of BMR, was demolished in 2017 due to an opportunity to expand the center and its services, and is being renovated at the time of writing. Construction is expected to conclude in late 2018. Other assets of the Bureau are listed in Appendix III.

## ACTIVITIES

---

### ADMINISTRATION

---

The Bureau’s administration is responsible for day to day administrative and financial matters affecting the operation and personnel of BMR. They also advise the director on the effectiveness of program requests by partners and stakeholders, as well as implications of funding cuts and priorities.

### PERMITTING

---

Table 3 below lists the permit types administered by the Coastal Division of the Bureau.

TABLE 3. PERMIT TYPES (NOT INCLUDING PERMITS ADMINISTERED BY THE DIVISION OF OCEANIC FISHERY MANAGEMENT).

Permit	Purpose	Procedure
1. Marine Research Permit	Any marine resources related research, including mariculture/aquaculture, scientific or medical research	BMR Regulation -Approved 01/06/2005

Permit	Purpose	Procedure
2. Aquarium Collection Permit	Collection of Aquarium Species for aquarium purpose / local aquarium	BMR Regulation -Approved 01/06/2005
3. Convention on International Trade in Endangered Species of Wild Flora and Fauna (CITES)	CITES listed species require this permit for export	CITES Signatory since 2004
4. Aquaculture Package	Maricultural / Aquacultural	Applicants must obtain land use permit from the Environmental Quality Protection Board (EQPB)

TABLE 4. RESEARCH PERMITS APPLIED FOR IN 2017.

Permit #	Validity Date	Institution
RE 17-01	01/01/17 - 12/31/17	Biota Incorporation
RE 17-02	01/06/17 - 01/18/17	University of Texas, Austin
RE 17-03	01/06/17 - 12/31/17	Micronesian Shark Foundation
RE 17-04	01/01/17 - 12/31/17	Palau International Coral Reef Center
RE 17-05	01/01/17 - 12/31/17	Pharma Mar, S.A.
RE 17-06	03/04/17 - 03/18/17	Seikai National Fisheries Research Institution
RE 17-07	03/29/17 - 05/13/17	The University of Queensland, Australia
RE 17-08	04/01/17 - 12/31/17	Fukui Prefectural University/Southern Marine
RE 17-09	03/01/17 - 12/13/17	University of Park, PA / Department of Biology
RE 17-10	03/01/17 - 12/31/17	Scripps Institution of Oceanography, CA USA

Permit #	Validity Date	Institution
RE 17-11	03/24/17 - 12/31/17	Univ. of Miyazaki / Southern Marine Laboratory
RE 17-12	02/27/17 - 12/31/17	Coral Reef Research Foundation
RE 17-13	05/01/17 - 05/19/17	Bermuda Institute of Ocean Science
RE 17-14	04/04/17 - 04/27/17	University of California, Santa Barbara
RE 17-15	04/17/17 - 12/31/17	University of California, Merced
RE 17-16	05/01/17 - 12/31/17	JAMSTEC
RE 17-17	<i>Permit not processed</i>	Ocean University of China
RE 17-18	06/01/17 - 08/31/17	Save the Nautilus & Central Camputs
RE 17-19	05/01/17 - 12/31/17	Aqua Marine Center
RE 17-20	<i>Permit not processed</i>	KIOST
RE 17-21	06/22/17 - 07/15/17	Scripps Institution of Oceanography
RE 17-22	06/01/17 - 12/31/17	Stanford University, Hopkins Marine Station
RE 17-23	07/22/17 - 07/30/17	University of Hong Kong
RE 17-24	08/29/17 - 09/07/17	University of Colorado
RE 17-25	09/23/17 - 10/01/17	Mie, Japan
RE 17-26	10/01/17 - 12/31/17	New Castle University, United Kingdom
RE 17-27	11/02/17 - 11/09/17	Yamagata University, Faculty of Science
RE 17-28	11/16/17 - 12/09/17	Japan Fisheries Research and Education Agency / Shunyo Maru
RE 17-29	12/03/17 - 12/15/17	California Academy of Sciences
RE 17-30	12/01/17 - 12/05/17	Research Center for Life and Environmental Science, Toyo Japan
RE 17-31	12/15/17 - 12/19/17	Faculty of Science, Shizuoka University
RE 17-32	09/09/17 - 09/14/17	The University of the Ryukyus, Okinawa, Japan

## DIVISION OF COASTAL FISHERIES MANAGEMENT

### OVERVIEW

---

The Division of Coastal Fisheries Management works collaboratively with the States alongside other partners and stakeholders to plan, develop, manage, and enforce regulations on coastal fisheries, aquaculture, and vulnerable/endangered species, with the ultimate goal of ensuring long-term sustainability and contributing to livelihood and food security. The Division is responsible for working with States, partners, and stakeholders to develop management plans, to collect data on key fisheries, aquaculture, and vulnerable/endangered species, and to assist and participate in research and monitoring activities related to all coastal marine resources.

The Division employs eight permanent staff who are supported by two contract staff. Of the permanent staff, one is a fisheries specialist, one is an administrative specialist who oversees data entry and analysis, and six are coastal fisheries officers. Three positions are vacant: one for the position of Chief of Division, one for a coastal fisheries scientist, and one for a coastal fisheries management specialist.

### DATA COLLECTION

---

#### *Marine Export Declarations (MEDs)*

---

All exports of marine products from Palau require the completion and filing of Marine Export Declaration (MED) forms to the BMR. The declaration forms contain the common name (English or Palauan) and Latin name of the species to be exported, the quantity (pieces and weight), the origin of the product, its use (commercial, personal or scientific), name of the exporter, the destination, and other fields. In the “use of product” category, '*commercial*' refers to marine products exported for on-selling, '*personal*' refers to marine products exported for personal use (consumption or gift), and '*scientific*' refers to marine products exported for research purposes. This information is stored in the BMR database.

A total of 4,884 MED forms were issued in 2017 (figure 2). Of these, 94% were issued for personal purpose and 3% each for commercial and scientific purposes (see table 5). July saw the highest number of personal exports, coinciding with summer holidays, high school and university graduations in Guam and Hawaii, and State elections in Palau, for which gatherings were held for Palauans living overseas and where fish and other food is commonly offered.

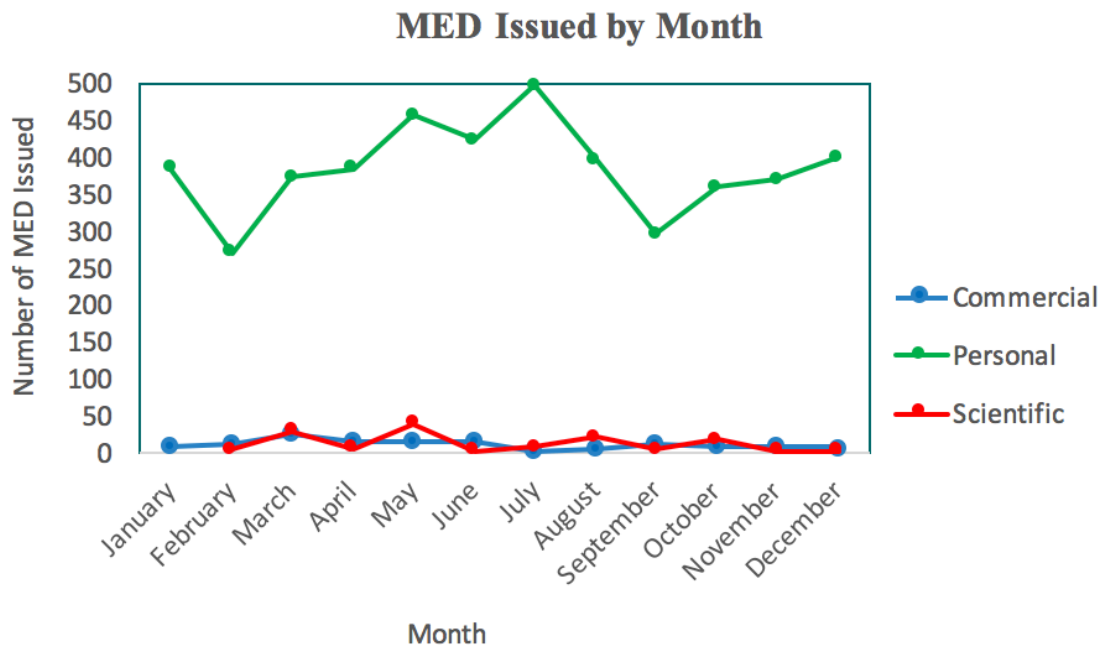

FIGURE 2. MARINE EXPORT DECLARATIONS ISSUED BY MONTH IN 2017.

An estimated 97.35 mt of marine products were exported for commercial and personal use in 2017. It should be noted that this estimate only includes whole reef fish; it does not include sliced, filleted, or cooked reef fish, or the weight of tuna, billfish, barracuda, moonfish, wahoo, Spanish mackerel, rays, eels, or other exported species for which weights could not be estimated.

TABLE 5. MARINE EXPORT DECLARATIONS RECORDED BY BMR FOR 2017.

Purpose	MEDs Issued	Proportion (%)	Weight (kg; whole specimens only)	Estimated value
Commercial	137	3	11,224.26	\$62,290.55
Personal	4609	94	86,129.46	\$502,237.70
Scientific	138	3	No weight recorded*	No value recorded*
<b>Total</b>	<b>4884</b>		<b>97,353.72</b>	<b>564,528.25</b>

\*Most scientific exports involve tissue samples or otherwise small parts of whole specimens; for this reason, whole fish weight and value was not estimated.

Although all exported marine products should be weighed before or during inspection at the airport, for various reasons this is not always done. For marine products that were not weighed, weights were estimated using published length-weight relationships on FishBase ([www.fishbase.org](http://www.fishbase.org))<sup>1</sup> and from research conducted in Micronesia (Lindfield et al. 2015)<sup>2</sup>, as well as unpublished length-weight relationships of commercial reef species from Palau (Lindfield 2015, unpublished data). Length-weight relationships were used by inputting the average size of a given species to generate the estimated weight of an individual, then extrapolating. However, this is not an ideal method for estimating fish weight, for several reasons:

- a) Fish are often taken to the airport frozen (bent or flat) in coolers, making it difficult to estimate the length of individual fish.
- b) Some fish were recorded as fillet, sliced, or cooked (smoked), and no weight was recorded on the respective MED forms. In these cases, a lack of information makes weight estimates difficult or impossible to generate. For example, it is often not known if fillets or cooked fish originated from a single fish or from multiple specimens.

<sup>1</sup> Froese, R., Pauly, D., 2013. FishBase [WWW Document]. URL <http://www.fishbase.org/>

<sup>2</sup> Lindfield, S.J., Harvey, E.S., Halford, A.R., McIlwain, J.L., 2015. Mesophotic depths as refuge areas for fishery-targeted species on coral reefs. *Coral Reefs* 35, 125–137.

c) Fish are often exported in mixed assemblages, and airport staff, due to time constraints, rely on the species information provided by those exporting the fish. However, Palauan species names do not always correspond to scientific species names, which results in a low species-specific resolution in some taxa. In some cases, this makes it impossible to determine the correct species for length-weight relationships and can yield unreliable results, especially for species groups that consist of a wide spectrum of sizes (e.g. emperors, snappers, wrasses).

For these reasons, our estimates of exported quantities are underestimates. The issues with data collection and analysis are limitations of this program and will need to be addressed to improve the accuracy of data collected and the usefulness of their interpretation to export monitoring. A number of suggestions for improvement are provided in the section ‘Challenges and Opportunities’ below. These will be expanded on in a forthcoming assessment of BMR’s overall data management.

---

### *Commercial exports*

---

Commercial exports include fish for consumption as well as species for the aquarium trade such as giant clams, soft corals, and various cultured and wild-caught fish species. Seventy-six of the 137 MEDs issued for commercial purposes were for the exportation of reef fish to Guam, the main importer of reef fish from Palau (see table 6 for all destinations). Other countries predominantly imported giant clams and soft corals for the aquarium trade.

An estimated 11.2 mt (92%) of reef fish were exported for commercial purposes, and were all sent to Guam where they were resold for consumption. The three main fish families exported for commercial purposes were Scaridae (Parrotfish, 65%), followed by Acanthuridae (Surgeonfish, 18%) and Siganidae (Rabbitfish, 12%) (table 7). Exports to China, Germany and Other countries were for the aquarium trade (table 7), for which no weight data are currently available.



TABLE 6. DESTINATION COUNTRIES FOR COMMERCIAL EXPORTS. MEDS = MARINE EXPORT DECLARATIONS. COUNTRIES IN THE "OTHER" CATEGORY INCLUDE MAINLAND USA, ENGLAND, JAPAN, AND SINGAPORE.

Country	Number of MEDs	Estimated quantity (kgs)
China	5	n/a
Germany	7	n/a
Guam (USA)	76	11,200
Other	49	n/a
<b>Total</b>	<b>137</b>	<b>n/a</b>

TABLE 7. ESTIMATED COMMERCIAL EXPORTS OF COASTAL PRODUCTS FROM PALAU IN 2017.

Family Common name	Local name	Qty (pieces)	Weight estimate (kg)
Emperor	Besechamel	230	116.16
Goatfish	Dech/Bang	176	81.55
Mackerel	Desui/Smach	42	23.13
Milkfish/Mullet	Aol	17	16.15
Parrotfish	Mellemau	11,195	7,249.04
Rabbitfish	Meyas	4,297	1,338.07
Rudderfish	Teboteb	38	41.44
Snapper	Keremlal	378	236.44
Soldier/Squirrel	Desachel	76	27.22
Surgeonfish	Merbas	87	87.39
Unicornfish	Um	2,409	1,994.02
Wrasse	Budech	38	13.61
<b>Grand Total</b>		<b>18,983</b>	<b>11,224.22</b>

*Note: The weights of barracuda, billfish, moonfish, wahoo, eels, rays, tuna, spanish mackerel and other fish species could not be estimated due to the uncertainty of the size of exported specimens or their parts.*

---

*Personal exports*

---

MED forms for personal use were divided into two categories by fish families for easy sorting (“Mix” and “Only”). The “Mix” category are MED forms that combine multiple families of species (e.g. parrotfish, rabbitfish, giant clams etc.). The “Only” category are MED forms for a single family or species (e.g. giant clam).

Most (4,475 forms, or 97%) MED forms completed were of the “Mix” category, indicating that Palauans generally take a mixture of species overseas for personal use. Of the 134 forms in the “Only” category, 34 were issued for aquarium fish, 48 for giant clam, 51 for seashells (not including giant clamshells), and one for sand.

An estimated 86 mt (86,768 kgs) of reef fish and 0.6mt (620 kg) of other reef products (bivalves, crustaceans, gastropods, etc.) were exported for personal purposes (tables 8 and 9).

TABLE 8. ESTIMATED EXPORTS OF COASTAL PRODUCTS FOR PERSONAL PURPOSES FROM PALAU IN 2017.

Species	Qty (pieces)	Weight estimate (kg)
Angelfish/Batfish/Butterflyfish	44	34.14
Boxfish/Porcupinefish	71	57.87
Emperor	9,035	6,102.51
Goatfish	2,164	814.07
Herrings, Sardines, Sprats	479	24.44
Jacks/Scad/Trevally	2,101	1,328.43
Mackerel	720	498.22
Milkfish/Mullet	2,514	1,259.67
Mojarra	336	93.21
Parrotfish	41,499	24,433.01
Rabbitfish	39,166	10,039.64
Rudderfish	902	581.82
Snapper	14,890	7,543.77

Species	Qty (pieces)	Weight estimate (kg)
Soldier/Squirrel	1,392	532.24
Surgeonfish	5,010	1,890.19
Sweetlip	763	1,006.32
Triggerfish	65	110.51
Unicornfish	31,386	29,582.48
Wrasse	502	196.15
<b>Grand Total</b>	<b>153,039</b>	<b>86,128.69</b>

*Note: The weight of barracuda, billfish, moonfish, wahoo, eel, rays, tuna, Spanish mackerel and other fish species could not be estimated due to the uncertainty of the size of exported specimens or their parts.*

TABLE 9. ESTIMATED EXPORTS OF COASTAL PRODUCTS (OTHER THAN REEF FISH) FOR PERSONAL PURPOSES FROM PALAU IN 2017.

Species	Local name	Individuals	Packs
Ringworm	Ngimer		7
Mangrove clam	Ngduul	448	68
<i>Crustaceans</i>		40890	382
Crab	Echoech		3
Crab	Kesakou	50	10
Land crab	Kesuar	30	
Blue manna crab	Kmai	3	1
Land crab	Rekung	3516	258
Land crab (meat)	Rekung (meat)		34
Crab	Rereik	20	
Crab	Senges	15	
Prepared crab meat	Ukaib	37256	76
<i>Gastropods</i>			5
Coral worm snail	Eol		4
Tiger conch	Smachel		1
<i>Holothuroidea</i>			906

Species	Local name	Individuals	Packs
Sea cucumber sp.	Edelngor		5
Sea cucumber sp.	Irimd		85
Curry fish	Ngimes		796
Sea cucumber sp.	Sekesakel		20
Seashells (bivalves & snails)	Kai	1014	
<i>Polyplacophora</i>		20	
Chiton	Echui	20	
<b>Grand Total</b>		<b>42,372</b>	<b>1,368</b>

*Note: Species groups and amounts exported given in italics, with specific taxa listed underneath the respective group. 'Packs' denotes bags or boxes in which specimens were exported (may contain any number of individuals).*

### *Scientific exports*

Scientific exports are often tissue samples of marine species preserved in solutions, or pieces that are dried. Most scientific exports in 2017 were hard coral samples exported to universities or research institutes (see figure 3 for information by country). However, samples of sponges, algae, fish, soft corals and giant clams were also exported for scientific and biomedical research.

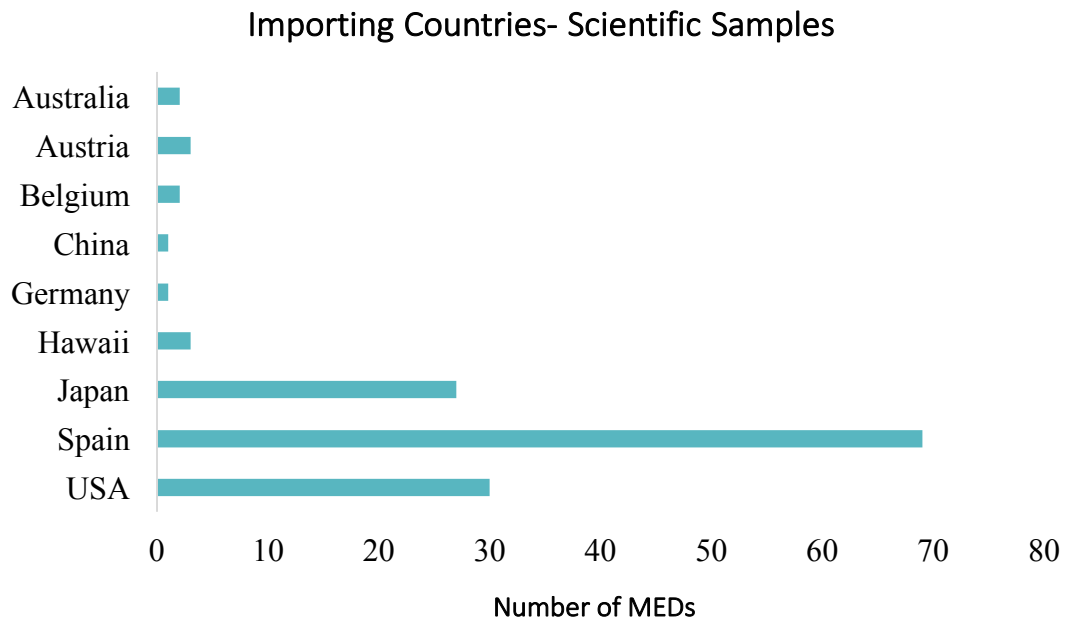

FIGURE 3. MARINE EXPORT DECLARATION FORMS FOR SCIENTIFIC RESEARCH, BY COUNTRY OF DESTINATION FOR 2017.

### FISH MARKET DATA

---

The Creel and Market Survey program collects information on the types, quantity and sizes of marine species at the main landing site in Koror, the JR-5 Central Market. The program has improved significantly over recent years with the utilization of stereo-video, a new technology for recording the species composition and lengths of reef fish. This improvement minimizes interference and disruption to fishers at the landing site. The report of the program is expected to be published in 2019 by staff of BMR’s Coastal Division; preliminary information will be included in the 2018 Annual Report if available.

## ANNUAL SPORTS FISHING TOURNAMENT - ETPISON CUP

Sport fishing data are collected annually at the Palau Sports Fishing Association's (PSFA) annual fishing tournament, featuring the Etpison Cup (table 10), which is held in May of each year.

TABLE 10. OFFICIAL DATA FOR THE 2017 ETPISON CUP. FISHERS MAY PARTICIPATE IN ONE OR MORE CATEGORIES (E.G. TROLLING AND GT CATCH AND RELEASE).

Category	#boats	#fishers	Species landed	Species released
			Pcs	
		(m = male, f = female)	Pcs	Weight (kg)
				Estimated weight (kg)
<b>Trolling</b>	23	88 (m)	63	476.5
<b>Ladies' bottom fishing</b>	4	22 (f)		48.1
<b>GT Catch &amp; Release</b>	6	24 (m)		Giant trevally 86.6
<b>Total</b>	27	110 (m=88, f=22)		

---

## THREATENED, ENDANGERED AND PROTECTED (TEP) SPECIES

---

---

### *CITES permits issued*

---

Palau became a signatory to the Convention on International Trade of Endangered Species of Wild Flora and Fauna (CITES) in 2004. The aim of the convention is to ensure that international trade in specimens of wild animals and plants does not threaten their species' survival.

As part of Palau's obligations to the Convention, a permit is required for any export of species – whole or in part, dead or alive – listed on Appendix I or II of CITES. The majority of CITES permits issued in Palau are for the export of giant clams, with a smaller number of permits issued for hard corals and nautilus (*Nautilus belauensis*). In 2017, 177 CITES permits were approved and issued (Appendix III). CITES permits are processed at the Bureau and attached to the relevant MED form(s) for shipment.

---

### *Giant clam exports*

---

In 2017, 90% of giant clams exported were used for commercial purposes, with 10% for personal use and <1% for scientific purposes. The majority of giant clam exports were for the commercial aquarium trade to the USA (51%), followed by Germany (20%), China (21%), Singapore, Austria, and England (8%) (see figure 4). Personal exports of giant clams are mostly shells and meat, while a small number are exported live for use in personal aquaria (table 11 and 12). By law, only cultured giant clams may be exported from Palau. While maintaining control over wild stocks has been a challenge for the Bureau, the traceability of cultured clams is currently low. To enforce the ban on the export of wild-caught clams, the BMR requires invoices from clam farmers to determine the point of origin when applying for CITES permits. This is reinforced by periodic monitoring of the inventory of individual clam farms to determine if the clams listed on invoices are cultured or wild-caught.

## Giant Clam CITES Permits - Importing Countries

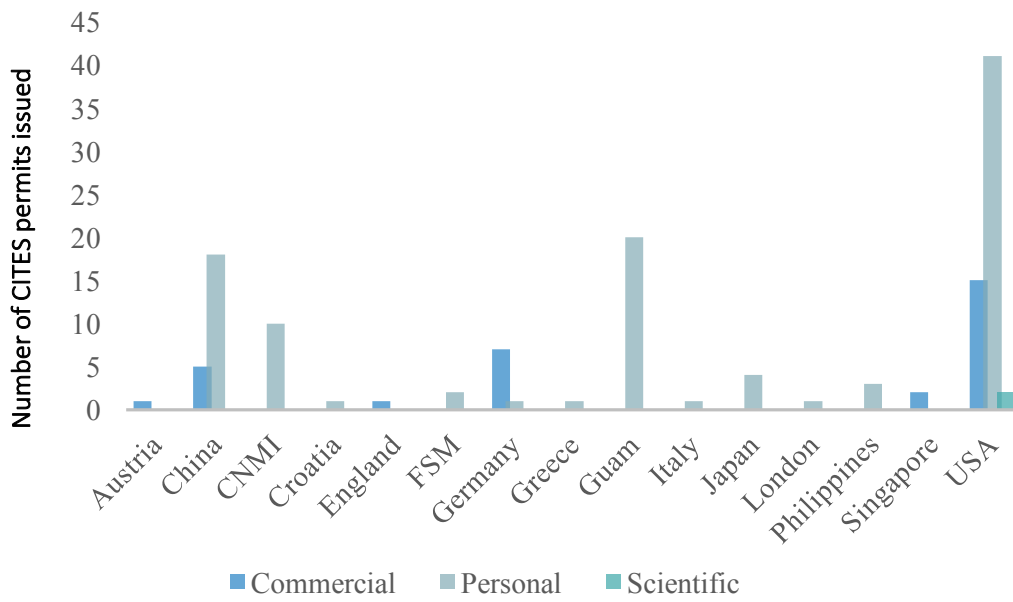

FIGURE 4. CITES PERMITS ISSUED BY COUNTRY IN 2017.

TABLE 11. THE NUMBER OF GIANT CLAMS EXPORTED FOR COMMERCIAL, PERSONAL, AND SCIENTIFIC PURPOSES IN 2017. NOTE THAT HALF CLAM SHELLS ARE SOMETIMES EXPORTED AND REPRESENTED AS SUCH.

Species	Commercial	Personal	Scientific	Total
<i>Tridacna crocea</i>	3882	95	25	4002
<i>Tridacna derasa</i>	5200	262	21	5483
<i>Triadacna gigas</i>		1	2	3
<i>Hippopus hippopus</i>	338	864.5	6	1208.5
<i>Tridacna maxima</i>	1307		10	1317
<i>Tridacna noae</i>	12			12
<i>Tridacna squamosa</i>	711	25	10	746
<b>Total</b>	<b>11,450</b>	<b>1,247.5</b>	<b>74</b>	<b>12,771.5</b>



TABLE 12. DETAIL OF THE NUMBER OF GIANT CLAMS EXPORTED LIVE OR IN PARTS.

Species	Live	Meat	Shell	Samples	Total
<i>Tridacna crocea</i>	3917	6	18	61	4002
<i>Tridacna derasa</i>	5210	190	18	65	5483
<i>Triadacna gigas</i>			2	1	3
<i>Hippopus hippopus</i>	358	781	6	63.5	1208.5
<i>Tridacna maxima</i>	1307		9	1	1317
<i>Tridacna noae</i>	12				12
<i>Tridacna squamosa</i>	711	11	8	16	746
<b>Total</b>	<b>11,515</b>	<b>988</b>	<b>61</b>	<b>207.5</b>	<b>12,771.5</b>

---

### *Nautilus exports*

---

Four CITES export permits were issued for *Nautilus belauensis* (three permits for personal use and one for scientific purposes). *N. belauensis* is listed on Appendix II of the Convention on International Trade in Endangered Species of Wild Fauna and Flora.

---

### *Hard corals*

---

Hard corals can only be exported if cultured, unless they are exported for scientific purposes. To export hard corals for scientific experiments, persons who wish to export parts of wild hard corals must hold a valid research permit approved by the Minister. There is currently no aquaculture of hard corals in Palau, and hence no export for commercial or personal purposes.

In 2017, 4,646 pieces of hard coral were exported. This compares to 2,595 pieces in 2016 and 7,996 pieces in 2015, respectively. Table 13 provides a list by species and quantity (pieces) of hard corals exported in 2017. Hard corals were either exported in tissue form (pellets or on filter) stored in solution, as skeletons, as fragments, or as larvae.

TABLE 13. HARD CORAL EXPORTS FROM PALAU IN 2017.

Species	Quantity (pieces)	Species	Quantity
<i>Acropora</i>	596	<i>Heteropsammia cochlea</i>	13
<i>Acropora tenella</i>	2	<i>Heteropsammia sp.</i>	24
<i>Anacropora sp.</i>	1	<i>Javania sp.</i>	6
<i>Antipath elegans</i>	1	<i>Leptoseris gardineri</i>	7
<i>Antipathes abies</i>	1	<i>Leptoseris sp.</i>	5
<i>Antipathes bifaria</i>	1	<i>Lillipathes sp.</i>	1
<i>Antipathes elegans cf.</i>	2	<i>Lobopyllia sp.</i>	2
<i>Antipathes n. Sp.</i>	2	<i>Madracis asanoi</i>	4
<i>Antipathes sp.</i>	14	<i>Madracis sp.</i>	2
<i>Antipathes spinulosa</i>	1	<i>Montipora</i>	25
<i>Aphanipathes reticulata cf.</i>	4	<i>Myriopathes japonica</i>	1
<i>Aphanipathes sp.</i>	7	<i>Myriopathes sp.</i>	3
<i>Aropora tenella</i>	3	<i>Pachyseries</i>	84
<i>Asteriopathes p.</i>	7	<i>Pachyseries rugosa</i>	262
<i>Asteriopathes sp.</i>	1	<i>Paracyathus sp.</i>	4
<i>Bathypathes sp.</i>	1	<i>Parantipathes sp.</i>	10
<i>Caryophyllia sp.</i>	31	<i>Pocillopora</i>	204
<i>Caulastrea sp.</i>	6	<i>Pocillopora damicornis</i>	287
<i>Cirrhopathes anguina cf</i>	2	<i>Pocillopora meandrina</i>	25
<i>Cirrhopathes sp.</i>	6	<i>Pocillopora sp.</i>	163
<i>Cladopsammia sp.</i>	1	<i>Pocillopora vernicosa</i>	2
<i>Coral (unknown)</i>	850	<i>Porites</i>	83
<i>Corallium sp.</i>	2	<i>Porites cylindrica</i>	622
<i>Culicia sp.</i>	25	<i>Porites rus</i>	467
<i>Cycloceris sp.</i>	2	<i>Porites lobata</i>	50
<i>Cynarina sp.</i>	30	<i>Psammacora sp.</i>	5

Species	Quantity (pieces)	Species	Quantity
<i>Dacropora digitifera</i>	6	<i>Pteridopathes sp.</i>	8
<i>Dactylortochus sp.</i>	4	<i>Rhipidopathes sp.</i>	1
<i>Dendrophyllia sp.</i>	5	<i>Rhizopsammia sp.</i>	31
<i>Dendrophyllia velta</i>	1	<i>Rhizotrochus sp.</i>	1
<i>Desmophyllum sp.</i>	5	<i>Seriatopora sp.</i>	2
<i>Distichopora borenlis</i>	1	<i>Stichopathes sp.</i>	5
<i>Distichopora irregularis</i>	5	<i>Stylaster campylecus</i>	1
<i>Distichopora sp.</i>	14	<i>Stylaster sp.</i>	22
<i>Enallopsammia sp.</i>	2	<i>Stylaster tenisonwoodsi</i>	2
<i>Eyphyllia sp.</i>	2	<i>Stylophora pistillata</i>	31
<i>Fungia sp.</i>	4	<i>Stylophora sp.</i>	1
<i>Galaxea sp.</i>	1	<i>Tubastraea sp.</i>	115
<i>Goniastrea</i>	374	<i>Tubipora sp.</i>	1
<i>Goniopora sp.</i>	9	<i>Turbinaria renformis</i>	25
<i>Heliopora sp.</i>	2	<i>Turbinaria sp.</i>	5
<b>Total</b>			<b>4,646</b>

### *Airport Confiscations*

In 2017, 123 cooler inspections for marine products occurred at Roman Tmetuchl International Airport. One confiscation was filed by the Coastal Fisheries Officers on October 5, 2017. The officers had found 1.48 kg of raw *Tectus niloticus*<sup>1</sup> (*semum*), 1.07 kg of cooked *T. niloticus*, and 3.25 kg of cooked sea turtle (*uel*) meat in coolers presented by a Governor from Babeldaob. The coolers were said to belong to an individual accompanying the Governor that night and were destined for Guam on flight #158.

<sup>1</sup> There has been a scientific name change for *Trochus niloticus* to *Tectus niloticus*

The confiscated items were brought to the BMR office for processing (figure 5). The items were documented and forwarded to the Division of Fish & Wildlife, Ministry of Justice.

FIGURE 5. EXAMPLE OF AIRPORT CONFISCATION. PROCEDURE INCLUDES CATALOGUING AND WEIGHING THE CONFISCATED ITEMS.

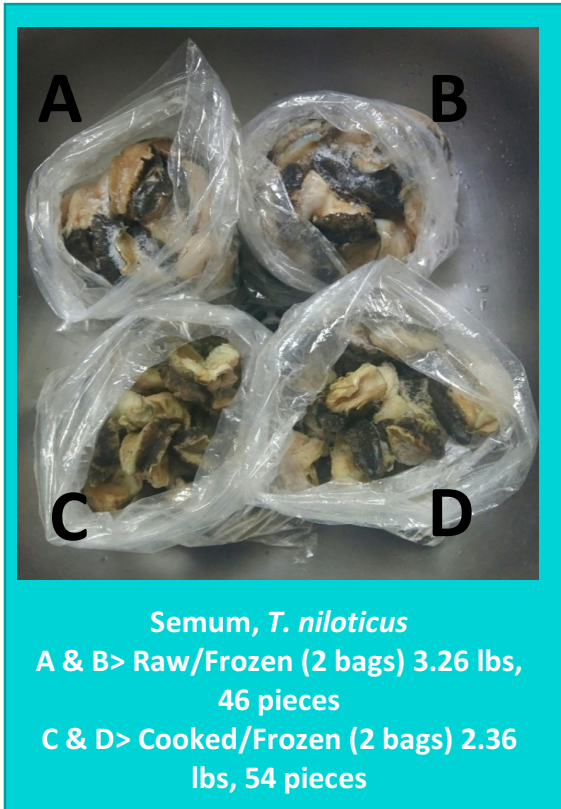

## CHALLENGES AND OPPORTUNITIES

---

### *Export data*

---

Limitations to this program, which should be addressed in the future, include the issues with calculating fish weights from limited data (usually only the average specimen in a cooler and known length to weight ratios) as well as the difficulty to determine weights for semi-processed large specimens. Therefore, our estimates of quantity exported are most likely underestimates.

To alleviate these issues, we suggest that BMR hire more staff to rotate airport shifts or that export inspections take place at BMR, during working hours. People could bring in their coolers to have their contents inspected, and sealed coolers could be kept in cold storage at BMR/PMDC until the flight. This would reduce the night shifts to one person (who could take coolers to their respective flights each evening) and improve working conditions for inspection staff. These jobs are often understaffed and a lack of accountability at the airport leads to customer complaints which can reflect negatively on the BMR and MNRET. Inspections at BMR would also allow for more time to inspect, identify species, and weigh cooler contents and would possibly reduce incidences of fee fraud.

BMR could also make it a requirement that fish are brought in fresh or, if frozen, separately (i.e. not mixed assemblages, no 75-pound blocks of solid frozen marine products that are difficult to inspect, identify and separate). Determining a standard size of cooler allowed for fish exports would also make the process easier, but may be difficult to enforce (BMR does not have authority to confiscate fish). For this reason, we should look into options for granting BMR inspection staff the authority to issue fines for attempts of illegal exports. Currently, this falls under the jurisdiction of Fish and Wildlife, a small team of less than a dozen people who are usually not able to come to the airport for such cases.

Another option to consider is outsourcing the collection of export data. This would require a budget and proposal for services and sourcing of funds but would free up BMR staff capacity and improve consistency in data collection. This would also allow us to assess and, if needed, overhaul data collection and entry methods to improve data extraction and analysis for future reports.

A final issue to consider is the lack of data collection on fish sales to restaurants and hotels. Given Palau's small population, it is concerning that local demand for fresh reef fish is often not met while coastal food fish stocks appear to be generally declining. As figures reported here show, the export of reef fish for personal use (known more commonly as the 'cooler trade') is substantial at around 90 metric tons annually. However, the amount of fish sold to local restaurants and hotels is likely to represent the vast majority of local reef fish sales and therefore will need to become part of the Bureau's data collection effort to allow for a more reliable estimate of total reef fish consumption. This in turn is an essential requirement for an informed approach to reef fisheries management in Palau.

## DIVISION OF FISHERIES DEVELOPMENT & AQUACULTURE

### OVERVIEW

---

The Division of Fisheries Development and Aquaculture is tasked with exploring and researching the sustainable development of fisheries resources with the goal of developing economically and socially viable marine resource production opportunities, in collaboration with partners and stakeholders. The Division maintains and operates national aquaculture facilities, conducts aquaculture research and development, and produces seedlings and fingerlings for partners and States to promote and support sustainable aquaculture in Palau. The Division is also mandated to maintain a Fish Aggregating Device (FAD) program and facilitate the development of sustainable and economically viable fishery cooperatives/associations.

The Division has a total of nine permanent and one contract staff supporting its operation. Of these, two employees work in the Aquaculture section and eight in Fisheries Development. The Chief of Division position is currently vacant.

### FISHERIES DEVELOPMENT

---

#### *FADs*

---

Palau has a long history of anchored Fishing Aggregation Device (FAD) use in artisanal and industrial fisheries development. The Fisheries Development Section of BMR developed the first FAD trials in coastal Palauan waters in 1980, when six deep-water offshore FADs were deployed.

Following these initial experiments with anchored FADs, there were sporadic FAD deployments in coastal waters during the 1990s to assist small-boat troll and hand-line fishers. The owners of domestic fishing companies were also known to set several FADs to assist their pole-and-line fishing ventures. After the year 2000, additional anchored FADs were set to aid pole-and-line skipjack fisheries as well as hand-line and jigging operations for larger tunas. In 2013, the Pacific Community donated materials for about 20 nearshore sub-surface FADs, to be deployed in Palau's coastal waters to support subsistence and artisanal fishers and with the underlying idea of

shifting some of the fishing effort on reef fishes to pelagic species. At the same time, the Palau Sports Fishing Association (PSFA) deployed, and has subsequently maintained, two anchored offshore FADs, which are mainly fished by recreational sports fishers. A total of 17 FADs have been deployed since 2013, including two offshore FADs deployed by the PSFA. Figure 6 illustrates the FAD locations from 2013 - 2017.

As of the end of 2017, no monitoring or maintenance of the FADs has been conducted; as such, it is not possible to state which FADs are still in place or have been lost, in what state are those still on location, or what maintenance may be required. However, a stakeholder meeting was held at BMR in September 2017, during which it was decided that the establishment, maintenance and monitoring of a nationwide FADs network should be made a priority for BMR in the coming years. As part of the effort to revive Palau's FADs fishery, a person is to be hired to lead the development of both a Strategic Plan for a nationwide FADs network and the network itself. FADs are regarded as an integral part of Palau's effort to improve local food security and livelihoods for local fishermen by promoting small-scale artisanal fisheries, tourism, and sports fishing.



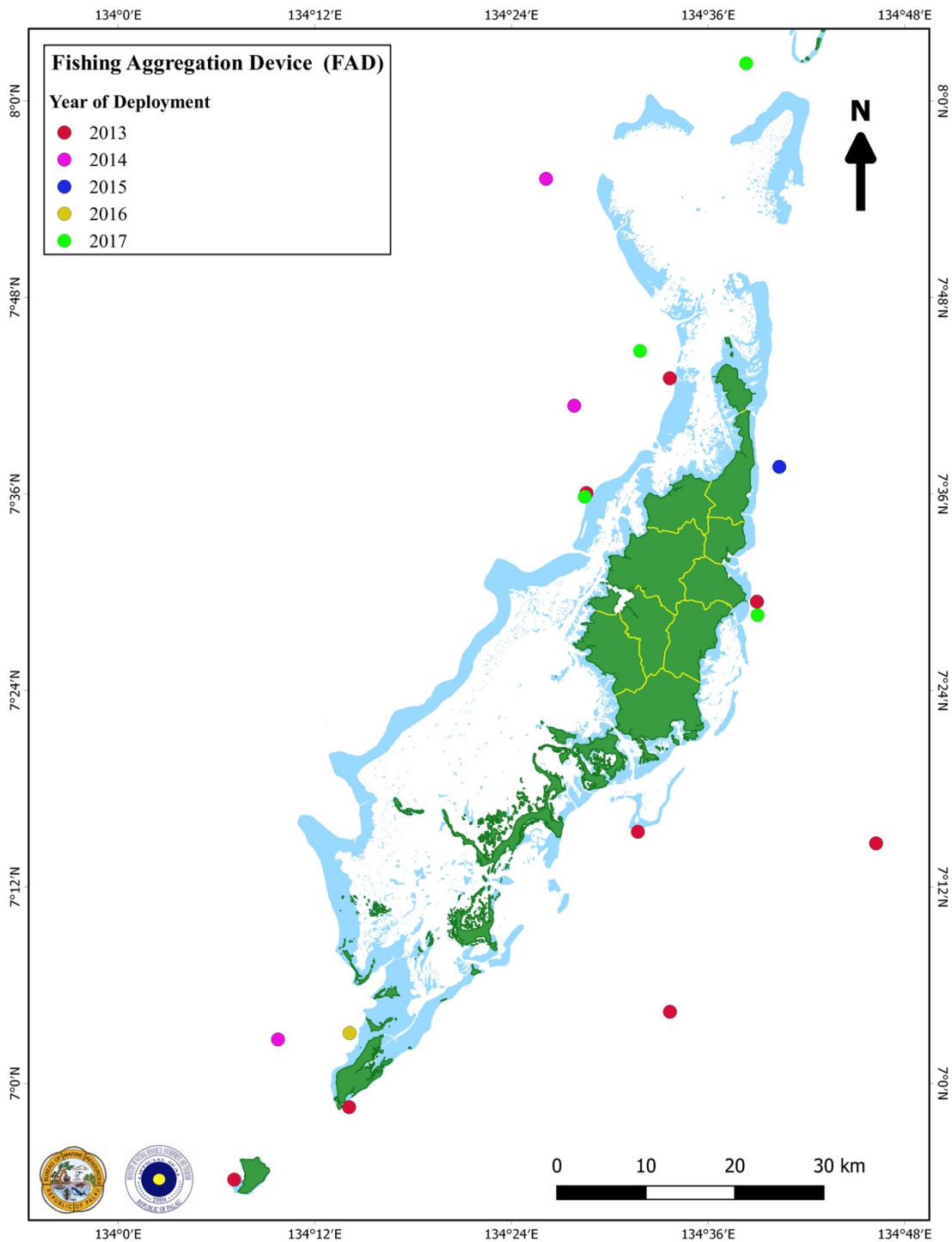

FIGURE 6. FAD DEPLOYMENTS FOR THE PERIOD 2013 TO 2017. NO MONITORING HAS BEEN CONDUCTED SINCE 2013; AS SUCH, PRESENCE OR ABSENCE OF THE FADS COULD NOT BE VERIFIED.

*Overseas Fishery Cooperation Foundation (OFCF) of Japan*

The Overseas Fisheries Cooperation Foundation’s (OFCF) assistance to Palau started in 1992. The goal of this program is to maintain and enhance goodwill relations in the fisheries field between Japan and Palau by way of extending technical and economic cooperation for the development and promotion of coastal fisheries and for effective management of marine resources. The assistance supports the

development of artisanal, subsistence, commercial, and export fisheries and has provided capital for six ice-making machines as well as several boats for State governments to assist fishing cooperatives. The program has also provided technical advisors who support infrastructure development, teach equipment operations, and introduce and promote various fishing, post-harvest, and aquaculture methods alongside resource management strategies.

The Overseas Fisheries Cooperation Foundation, as a part of fisheries development at the Bureau, faces several distinct challenges. The first of these is the constant turnover of administration within the group: staff retirement of cooperatives managers has led to limited institutional memory. Reporting and funding issues also limit progress to varying extents. The OFCF considers an improvement in the human resources capacity of BMR an important step to better serve employees and clients.

---

## AQUACULTURE DEVELOPMENT

---

Giant clam production has been operational in Palau since the 1970s. For many years, giant clam culture has been Palau's most important aquaculture activity, both for income generation and food security. There are currently around 60 giant clam farmers in Palau rearing clams of different species both for aquarium trade and domestic consumption. The development of the giant clam hatchery and rabbit fish aquaculture facility has become a high priority. BMR has received assistance from OFCF and National Taiwan Ocean University (NTOU) to further develop aquaculture growth. An assessment of BMR's giant clam and reef fin-fish breeding programs and associated technologies (such as brood stock development, feed, and maintenance operations) was recently completed and suggested the renovation of hatchery facilities to increase seed production and improvements in algae and live feed culture. Renovations of the Palau National Aquaculture Center (PNAC) at BMR were completed in 2017 with financial aid from the Government of Taiwan - Republic of China. Meanwhile, the Palau Mariculture Demonstration Center (PMDC) has been demolished and rebuilding commenced in October 2017, enabled by grant aid provided by the Japan International Cooperation Agency (JICA).

## GIANT CLAM MARICULTURE

### *Production*

In March 2016, the giant clam hatchery ceased operations and began renovations with funding assistance from Japan. All giant clam juveniles held at the hatchery were sold to farmers as seeds or transferred to the ocean nursery at the Palau Mariculture Demonstration Center (PMDC) by May 2017. It is anticipated that the PMDC will resume hatchery operations by September 2018.

Production of giant clam seeds had not been steady for the last five years (table 14). The number of seeds produced in 2013 was sufficient for *Tridacna derasa* and *Tridacna squamosa* but insufficient for *Tridacna maxima*, *Tridacna crocea* and *Hippopus hippopus*. As of December 15, 2017, BMR had a total of 22,647 juvenile and sub-adult (~7-8-year-old) stocks of clams, of which 89% were *H. hippopus* (table 15).

BMR had giant clam hatchery production technician assistance from SPC in 2013 and OFCF in November 2014.

TABLE 14. SUMMARY OF GIANT CLAM SEED PRODUCTION (2013-2017). AVERAGE\* IS THE AVERAGE NUMBER OF SEEDS BY SPECIES PRODUCED FOR YEARS WHEN SEEDS WERE PRODUCED.

Year	# Total pcs	<i>T. derasa</i>	<i>H. hippopus</i>	<i>T. squamosa</i>	<i>T. maxima</i>	<i>T. crocea</i>
2013	367,995	174,659	4,356	187,529		1,451
2014	198,294	2,908		8,701	37,053	149,632
2015	552,330	28,792	213,645	23,236	258,092	28,565
2016	91,752	91,752				
2017	No hatchery operations/production due to major renovation works					
Average*	302,600	74,530	109,000	73,150	147,570	59,890

TABLE 15. PMDC GIANT CLAM STOCK (AS OF DECEMBER 15, 2017).

Held at	Species	Batch #	Size	Number
Sub-pen @ POB	<i>T. derasa</i>	TD13-02/03	10 - 20 cm	707
Sub-pen @ POB	<i>H. hippopus</i>	HH15-01/02	4 - 12 cm	16,500
Sea bottom @ POB	<i>H. hippopus</i>	HH15-01/02	4 - 11 cm	2,200
BMR Fish Hatchery	<i>H. hippopus</i>	HH15-01/02	4 - 12 cm	1,400
Open-top Pen @ BMR	<i>T. derasa</i>	TD09/TD10	25 - 30 cm	1,840

### *Farm promotion and construction*

PMDC supports giant clam farmers in 10 of the 16 States in Palau, by providing training workshops, farm construction, repairs, and maintenance (table 16 and 17). Sixteen (16) farms were constructed in 2017 (see plate 1).

PMDC researched several kinds of farm and cage designs and has adopted the submersible pen – with dimensions of 6.1m (w) x 9.1m (l) x 0.6m (h) - as a standard model. This submersible pen has a gravel substrate rather than a natural bottom substrate. However, the installation and use of gravel bottom submersible pen is prohibited in Koror State. For this reason, PMDC needs to conduct further giant clam pen culture trials to be in line with Koror legislation.



PLATE 1. AQUACULTURE FARM CONSTRUCTION IN SEVERAL PALAUAN STATES.

TABLE 16. SUMMARY OF GIANT CLAM FARMS CONSTRUCTED OVER THE PERIOD 2013-2017 IN PALAU.

Year	Farms constructed	State (number of farms)
2014	1	Ngarchelong (1)
2015	6	Ngaraard (1), Ngaradmau (2), Aimeliik (1), Melekeok (1), Koror (1)
2016	22	Ngarchelong (4), Ngaraard (2), Ngiwal (1), Melekeok (6), Koror (8), Peleliu (1)
2017	16	Kayangal (5), Ngaraard (1), Ngchesar (1), Koror (8), Peleliu (1)

TABLE 17. GIANT CLAM FARM CONSTRUCTION DETAILS IN 2017.

#	Date	Hamlet/State	Type of the farm	Size	Remarks
01	02/01/2017	Meyuns/Koror	Nursery cage on stand	5' x 5'	New cage x4
02	02/01/2017	Meyuns/Koror	Sub-growout pen	20' x 30'	New
03	02/24/2017	Ngermid/Koror	Sub-growout pen	20' x 30'	New
04	03/02/2017	Meyuns/Koror	Sub-growout pen	13' x 30'	Old, Full Repair
05	03/16/2017	Ngerbeched/Koror	Nursery cage	4' x 10'	Recycled cage x1
06	04/07/2017	Kayangal	Submersible pen	20' x 30'	New
07	04/07/2017	Kayangal	Submersible pen	20' x 30'	New
08	04/07/2017	Kayangal	Submersible pen	20' x 30'	New
09	04/07/2017	Kayangal	Submersible pen	20' x 30'	New
10	04/07/2017	Kayangal	Submersible pen	20' x 30'	New
11	06/08/2017	Peleliu	Submersible pen	20' x 30'	New

1	06/28/201	Ngaraard	Submersible pen	20' x	New
2	7			30'	
1	09/26/201	Ngchesar	Submersible pen	20' x	New
3	7			30'	
1	11/16/201	Ngerbeched/Koro	Open-top pen	20' x	New extension
4	7	r		30'	
1	12/19/201	Metukerrikul/Kor	Sub-growout pen	20' x	New
5	7	or		30'	
1	12/27/201	Meyuns/Koror	Sub-growout pen	20' x	New
6	7			30'	

### *Seedling Distribution to Farms*

Giant clam seed (see plate 2) had been given to farmers at no cost for several decades until a change in policy was introduced in June, 2014. Currently, farmers have to pay for clam seeds produced by the PMDC, which contributes to the Giant Clam Seed Sustainability Project Fund (table 18). As a consequence, there was a slight decrease in demand for clam seeds in 2015 (table 19). In 2017, a total of 71,131 seed clams were distributed to 32 farmers, including the species *T. derasa* (49.2%), *H. hippopus* (38.4%), *T. squamosa* (2.7%), *T. maxima* (2.9%) and *T. crocea* (6.7%).

TABLE 18. GIANT CLAM SEEDLINGS CHARGES, EFFECTIVE JUNE 25, 2014.

Species	Cost for 1cm to 5cm	Cost for 5cm & above
<i>Tridacna maxima</i>	\$ 0.30 ea.	\$ 0.50 ea.
<i>T. crocea</i>	\$ 0.30 ea.	\$ 0.50 ea.
<i>T. derasa</i>	\$ 0.20 ea.	\$ 0.40 ea.
<i>T. squamosa</i>	\$ 0.30 ea.	\$ 0.50 ea.
<i>Hippopus porcellanus</i>	\$ 0.20 ea.	\$ 0.40 ea.
<i>H. hippopus</i>	\$ 0.20 ea.	\$ 0.40 ea.

TABLE 19. SUMMARY OF GIANT CLAM SEED DISTRIBUTION (2013-2017).

Year	# Total pcs	<i>T. derasa</i>	<i>H. hippopus</i>	<i>T. squamosa</i>	<i>T. maxima</i>	<i>T. crocea</i>
2013	58,224	31,979	8,303	7,382	9,060	1,500
2014	41,276	28,675	4,454	6,897	500	750
2015	32,869	7,775	17,500	973	0	6,621
2016	52,983	25,562	26,025	1,030	330	36
2017	71,131	35,000	27,300	1,953	2,083	4,795



PLATE 2. GIANT CLAM SEEDING AT BMR SUBSIDIZED CLAM FARMS AND SUBSEQUENT MONITORING AND HARVEST.

Many states are currently engaged in giant clam farming: In 2017, 39% of the seeds were sold to farmers in Koror, followed by 21% in Ngaraard and 12% in Ngarchelong (table 21). The most seeds distributed were *T. derasa* (49%) followed by *H. hippopus* (38%). The same table shows that the seeds of aquarium pet species such as *T. squamosa*, *T. maxima* and *T. crocea* are only distributed to limited states. The PMDC emphasizes the necessity of giant clam farming in terms of the food security, which is why *T.derasa* and *H.hippopus* seeds are widely distributed in Palau.

TABLE 20. GIANT CLAM SEED DISTRIBUTION BY SPECIES AND STATE IN 2017.

State	# Total pcs	<i>T. derasa</i>	<i>H. hippopus</i>	<i>T. squamosa</i>	<i>T. maxima</i>	<i>T. crocea</i>
Kayangel	6,000	1,000	5,000	0	0	0
Ngarcheloung	8,763	1,500	3,800	0	2,008	1,455
Ngaraard	15,000	9,000	6,000	0	0	0
Ngardmau	5,295	0	5,000	120	75	100
Ngiwal	2,500	1,500	1,000	0	0	0
Airai	1,000	1,000	0	0	0	0
Koror	28,073	17,000	6,000	1,833	0	3,240
Peleliu	4,500	4,000	500	0	0	0
<b>Total</b>	<b>71,131</b>	<b>35,000</b>	<b>27,300</b>	<b>1,953</b>	<b>2,083</b>	<b>4,795</b>

### *Wild stock enhancement*

The PMDC assists with giant clam stock enhancement activities conducted by state governments, state ranger offices, conservation groups, NGOs, and others. Prior to the closure of the old PMDC building and temporary cessation of operations, 2,900 sub-adult clams were provided to various partners for wild stock enhancement in various States (table 21). Several months after the planting, PMDC staff conducted follow-up monitoring surveys.

TABLE 21. SUMMARY OF PROVISION OF GIANT CLAMS TO CONSERVATION PROGRAMS (2013-2017).

Year	Number of clams provided	State (number and species)
2013	0	-
2014	0	-
2015	700	Koror/PPR (100 <i>T. derasa</i> ), Ngaraard (150 <i>T. derasa</i> & 150 <i>H. hippopus</i> ), Melekeok (150 <i>T. derasa</i> & 150 <i>H. hippopus</i> )



Year	Number of clams provided	State (number and species)
2016	1,200	Peleliu (300 <i>T.derasa</i> ), Angaur (200 <i>T.darasa</i> ), Airai (700 <i>T.derasa</i> )
2017	1,000	Peleliu (340 <i>T. derasa</i> & 60 <i>H.hippopus</i> ), Ngaradmau (600 <i>H.hippopus</i> )

### *Giant Clam Farm Monitoring (Collaboration with PALARIS)*

A nationwide in-water survey of giant clams was conducted during the summer of 2017 (June-August). As of that time, a total of 54 live giant clam farms were in operation, with 79,619 clams total. This work was done in collaboration with the Palau Automated Land and Resources Information System (PALARIS).

### FIN FISH CULTURE

Palau National Aquaculture Center (PNAC) was established in 2010 to conduct research into finfish production, including grouper (*Epinephelus fuscoguttatus*), rabbitfish (*Siganus lineatus*, *S. fuscescens*), clownfish (*Amphiprion ephippium*) and shrimp, also known as tiger prawn (*Penaeus monodon*; see figure 7). It also has the equipment and capability to produce live feed. The Center has collected rabbit fish broodstock since 2015, with the first batch of ~1300 fries successfully produced in June, 2015. Since then, several batches of rabbitfish fry have been produced. In 2016, approximately 4,000 rabbitfish fry at sizes between 4-9cm were sold to local farmers in Palau, at a price of \$0.05 each. In 2017, a total of 28,000 fry were produced (table 22). Other species farmed at the PNAC are not currently being sold.



FIGURE 7. WORKERS OUTSIDE THE PALAU NATIONAL AQUACULTURE CENTER.

TABLE 22. RABBIT FISH (*SIGANUS LINEATUS*/KLSEBUUL) FRY PRODUCTION AND DISTRIBUTION IN 2017.

Hatch date	Species	Size	Amount
2017/2/8	Klsebuul	2~3cm	5,000
2017/4/8	Klsebuul	2~3cm	4,000
2017/4/28	Meyas	2~3cm	2,000
2017/6/7	Klsebuul	2~3cm	6,000
2017/8/3	Klsebuul	2~3cm	4,000
2017/10/1	Klsebuul	2~3cm	4,000
2017/12/29	Klsebuul	2~3cm	3,000
	<b>Total</b>		<b>28,000</b>

#### 2017 Rabbit Fish Fry Distribution

Date	Name	Location	Mode	Species	Size	Amount
2017/1/24	Hiroimi Nabeyama	Ngatpang	Sea cage	Klsebuul	6cm	2,000
2017/2/24	Barrett	Peleliu	Fish pond	Klsebuul	6cm	1,000
2017/3/7	Mathaw Elbelau	Ngchesar	Fish pond	Meyas and Klsebuul	6cm	1,600
2017/3/8	Brenice Ngirkelau	Airai	Sea cage	Meyas	6~9cm	1,200
2017/6/23	Hiroimi Nabeyama	Ngatpang	Sea cage	Klsebuul	6~9cm	2,000

Date	Name	Location	Mode	Species	Size	Amount
2017/7/18	Hiromi Nabeyama	Ngatpang	Sea cage	Klsebuul	6~9cm	2,000
2017/8/28	Godwin Ito	Koror	Sea cage	Klsebuul	5~6cm	2,000
2017/9/5	Ngermechau Klobak Association	Ngiwal	Sea cage	Klsebuul	4~5cm	2,000
2017/10/5	Hiromi Nabeyama	Ngatpang	Sea cage	Klsebuul	6~9cm	2,000
2017/11/8	Hiromi Nabeyama	Ngatpang	Sea cage	Klsebuul	6~9cm	2,000
2017/11/13	Brenice Ngirkelau	Airai	Sea cage	Klsebuul	6cm	2,000
2017/11/22	Godwin Ito	Koror	Fish tank	Meyas	6~9cm	500
2017/12/20	Godwin Ito	Koror	Sea cage	Klsebuul	4~5cm	2,000
Total						22,300

### *Rabbitfish Floating Fish Cage/Fish Pen Construction*

Fish cages cost roughly \$1,630 USD in materials and pens cost roughly \$312 USD to create. Construction also requires the proper placement (in at least fifteen feet of water at lowest tide for the fish cage and at least 8 feet of water at lowest tide for the pen, figure 8), and the acquisition of a Point Source Pollutant Discharge Permit from the EQPB.

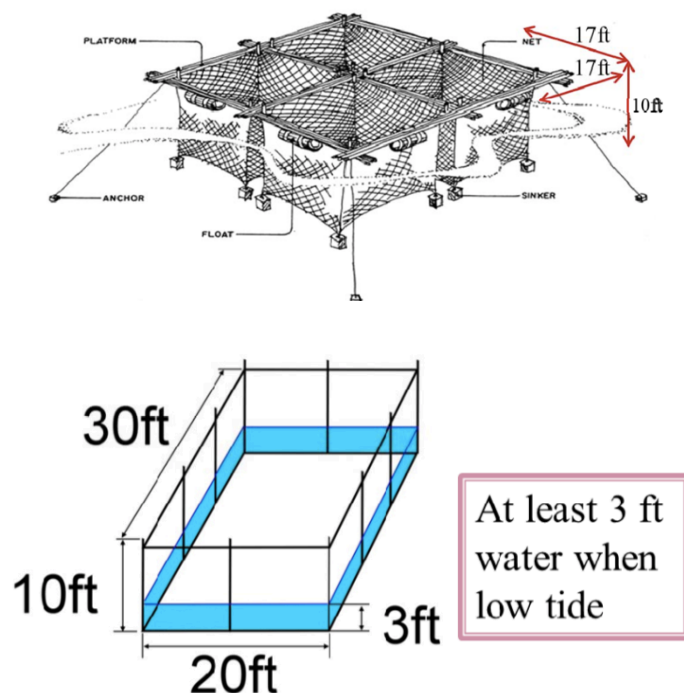

FIGURE 8. FLOATING FISH CAGE (ABOVE) AND FISH PEN (BELOW).

---

### *Donor Funding and Projects*

---

The Aquaculture Project (AP) was implemented in 2010 and is a joint initiative between the Republic of Palau and the Republic of China (ROC). This ROC-grant funded project is jointly implemented by the National Taiwan Ocean University (NTOU) and Palau's BMR.

The Taiwan Government built the hatchery in the Palau National Aquaculture Center and the NTOU provides the propagation experts, while the BMR shoulders power cost and utilities.

The overall goals of the project are: (1) to maintain the ecological balance of Palau's waters by building suitable aquaculture practices and conserving marine resources; and (2) to produce seafood by extending mariculture technology and establishing a mariculture industry in Palau, also reducing the overfishing impact on the environment and increasing food security.

## CHALLENGES AND OPPORTUNITIES

---

### *Aquaculture*

---

BMR's aquaculture initiatives have much room to grow in the coming years, however Palau's environmental regulations pose a challenge to aquaculture management. We suggest developing a legal baseline for environmental protection and aquaculture development, and to develop aquaculture under appropriate guidelines established by the Environmental Quality Protection Board.

BMR has identified rabbit fish as the most appropriate and economically viable target species for Palau. Therefore, we have entirely switched the focus of our fin fish aquaculture efforts from grouper to rabbit fish under the jointly funded BMR-ROC Aquaculture Project (AP). As the main producer of rabbit fish fry in Palau, BMR has concentrated its resources on expanding production capacity at the Palau National Aquaculture Center (PNAC) to yield adequate numbers of fry to stock the fish cages being built nation-wide with the support of The Nature Conservancy. In 2016, BMR requested assistance from the Government of Taiwan to develop the rabbit fish industry in Palau by supporting the expansion of the PNAC to accommodate increased production. At the time of writing, BMR's present output of fry produced at PNAC and distributed to the pilot farmers is limited because of the small numbers and size of the existing breeding tanks.

Another goal of the Aquaculture Project is to establish a healthy farming model. We aspire to do so by improving the feed management model, increasing fish disease prevention, and incorporating research and development to solve existing problems.

### *Fisheries Development/FADS*

---

Challenges distinct to FAD development are mainly the need for a sustainable National FAD program. A *Strategic Plan for the Development of a Nationwide anchored FADs Network* is in development now, but would benefit from technical and financial support over the coming year. The cost of running a successful and sustainable FADs program, including new materials, deployments, monitoring and evaluation schedule, and routine maintenance, is an important consideration and will

need to be explored carefully to ensure a feasible and sustainable program. Finally, questions over FAD ownership, i.e. whether the deployed FADs should remain under the ownership of the national government (BMR) or become the property of the States within whose waters they are placed, and what this will mean in terms of responsibility for maintenance, monitoring (data collection) and replacements, will need to be discussed with the relevant stakeholders early on to inform the development of the Strategic Plan and the program as a whole.

## DIVISION OF OCEANIC FISHERY MANAGEMENT

### ROLES AND RESPONSIBILITIES

---

The Division of Oceanic Fisheries Management is responsible for exploring, surveying, developing, managing and conserving all off-shore living and non-living resources within the contiguous and exclusive economic zones of Palau. The Division is tasked with establishing the total allowable level of foreign fishing, catch limits, and allocation in order to ensure the long-term sustainability and health of stocks of tuna and other pelagic species of fish, reef fish, and submerged reefs within the EEZ of Palau. This includes negotiating foreign fishing agreements, issuing foreign fishing permits, and performing other duties and functions for the management, utilization, and conservation of all living resources in the extended and exclusive fishery zone.

Title 27 of the Palau National Code is the primary fisheries legislation regulating the harvest of highly migratory fish stocks and fishing vessels that fish in the waters of the Republic of Palau.

The Division is headed by a Chief (position currently vacant) and has twelve staff supporting its operations. Two additional positions are currently vacant: Fisheries Law Compliance Officer II and Fisheries Extension Officer II.

### FLEET STRUCTURE

---

Palau's tuna fishery is dominated by offshore-based longline and purse seine fleets of Japan, and the locally based longline fleet of Taiwan - Republic of China (ROC).

BMR issues fishing permits to its bilateral partners as follows:

- 1) Offshore-based longline and purse seine
  - a. Four Fisheries Associations of Japan (FFAJ)
    - i. Federation of Japan Tuna Fisheries Cooperative Associations
    - ii. National Offshore Tuna Fisheries Association of Japan

- iii. Japan Far Seas Purse Seine Fishing Association
  - iv. Federation of Northern Pacific District Purse Seine Fisheries Cooperative Association of Japan
- b. Fairwell Fishery Group
- 2) Locally Based Foreign Fishing Companies
- a. Palau International Traders, Incorporated (PITI)
  - b. Kuniyoshi Fishing Company (KFC)
  - c. G & A Group Limited

## FISHING PERMITS

In 2017, Palau licensed a total 90 foreign fishing vessels - 58 longliners and 32 purse-seiners. Palau also registered and licensed two longline fishing vessels that are fully operated and managed locally as a domestic fleet. Table 23 shows the break-down of licensed vessels that operated in 2017 within Palau's EEZ by company, by gear and by flag.

TABLE 23. NUMBER OF LICENSES ISSUED BY GEAR AND FLAGGED VESSEL IN 2017. JP = JAPAN, PW = PALAU, TW = TAIWAN REPUBLIC OF CHINA.

Company	Longline			Purse-Seine		Total
	JP	PW	TW	JP	TW	
Fairwell Fishery Group	-	-	-	-	3	3
G&A Group Limited	-	2	-	-	-	2
Japan Far Seas Purse Seine Fishing Association	-	-	-	29	-	29
Kuniyoshi Fishing Company	-	-	8	-	-	8
National Offshore Tuna Fisheries Association of Japan	21	-	-	-	-	21
Palau International Traders Inc.	-	-	29	-	-	29
<b>Grand Total</b>	<b>21</b>	<b>2</b>	<b>37</b>	<b>29</b>	<b>3</b>	<b>92</b>



Palau also has agreements with multilateral partners under the Federated States of Micronesia Arrangement (FSMA) and the US Multilateral Fisheries Treaty (US Treaty). Vessels operating under the US Treaty rarely fish in Palau's EEZ because of its distance from transshipment ports and processing plants.

#### LONGLINE AND PURSE-SEINE CATCH

---

Total catch of pelagic fish reported for 2017, from both longline and purse-seine vessels, were 9,349 mt, consisting of 49 mt of albacore (*Thunnus alalunga*), 2322 mt of bigeye (*Thunnus obesus*), 3272 mt of skipjack (*Katsuwonus pelamis*), 3504 mt of yellowfin (*Thunnus albacares*), and 200 mt of other species. Palau's fishery port does not have infrastructure to accommodate purse-seine operations; as such, only the catch of longline vessels is landed in Palau's port at Malakal. Of the 2,181 mt that were landed at Malakal port, a total of 2,050 mt were exported, with Japan being the primary export destination. The rest were sold or donated locally based on the average price of \$3.80/kg (range = \$3.00 - \$6.00/kg), depending on the species and quality. Overall, catch landings increased in 2017 compared to 2016, as did the amount of catch that was exported or sold locally. Catch data are reported to the Scientific Committee of the WCPFC in two categories – Flag State Report and Coastal State Report. The former denotes the domestic fishery (Palauan owned and chartered vessels), while the latter sums catches of licensed foreign vessels.

Table 24 displays the breakdown of pelagic catches which Palau reports annually to the WCPFC. These comprise the catch of foreign vessels (shown under 'Coastal State') and the catch of domestic and chartered vessels (shown under 'Flag State') that fish in Palau's waters and those of countries with which Palau has multilateral fishing agreements. These catches are further categorized by gear (longline or purse-seine), flag (for vessels whose catch is reported under Coastal State) and species.

TABLE 24. BREAKDOWN OF CATCHES REPORTED BY PALAU TO THE WCPFC, BY THE DOMESTIC (NATIONAL AND CHARTERED VESSELS; FLAG STATE) AND FOREIGN FLEETS (COASTAL STATE). WITHIN THESE CATEGORIES, CATCH IS REPORTED BY FISHING GEAR, FLAG STATE AND SPECIES. FSM = FEDERATED STATES OF MICRONESIA, JP = JAPAN, KI = KIRIBATI, PNG = PAPUA NEW GUINEA, TW = TAIWAN.

a) Coastal State (CS) Catches (mt)							
Gear	Vessel	BET	SKJ	YFT	ALB	Other	Total
PS	FSM	0	41	25	0	0	66
PS	JP	6	1428	541	0	1	1976
PS	KI	0	0	0	0	0	0
PS	PNG	0	1701	1082	0	3	2786
PS	TP	0	100	0	0	0	100
<i>PS Total</i>							<b>4928</b>
LL	JP	1189.33	0	472.99	2.47	104.47	1769.26
LL	TW	21.81	0	31.91	0	1.15	54.87
<i>LL Total</i>							<b>1824.13</b>
<b>Total CS</b>							<b>PS Total + LL Total 6752.13</b>
b) Flag State (FS) catches (mt)							
Gear	Vessel	BET	SKJ	YFT	ALB	Other	Total
LL	National	27.37	0	36.52	0.04	2.86	66.79
LL	Chartered	1077.96	2.88	1314.8	47.2	88.01	2530.86
<b>Total FS</b>					<b>1</b>		<b>2597.65</b>
c) Total catch reported by Palau (mt)							
							<b>Total</b>
<b>CS &amp; FS</b>							<b>Coastal State + Flag State Totals 9349.78</b>

### *Domestic sales and donations*

Table 25 below shows the weight (mt) and value of pelagic catches that were sold or donated locally, by species and year (2014 – 2017). Local sales and donations normally constitute of lower grade (i.e. < A grade) tuna to hotels, restaurants, and other catering vendors.

TABLE 25. PALAU LOCAL SALES AND DONATIONS DATA 2014-2017 (PROVISIONAL).

Year	Species	Local Sales (mt)	Fish Value (USD)	Donation (mt)	Fish Value (USD)
2017	Bigeye	8.75	\$30,821.75	1.55	\$5,775.40
	Black Marlin	0.00	\$0.00	0.00	\$0.00
	Blue Marlin	0.38	\$1,196.85	1.47	\$4,846.70
	Pacific Bluefin	1.51	\$6,560.10	0.00	\$0.00
	Swordfish	1.18	\$3,914.50	0.39	\$1,339.50
	Yellowfin	27.14	\$95,910.60	6.20	\$22,842.35
	Others	1.70	\$5,944.40	0.23	\$794.05
<b>2017 Total</b>		<b>40.67</b>	<b>\$144,348.20</b>	<b>9.85</b>	<b>\$35,598.00</b>
2016	Bigeye	15.93	\$55,684.65	5.57	\$20,211.75
	Black Marlin	0.00	\$0.00	0.00	\$0.00
	Blue Marlin	0.32	\$1,123.50	5.75	\$19,999.00
	Pacific Bluefin	0.47	\$9,002.00	0.00	\$0.00
	Swordfish	1.95	\$6,674.20	0.48	\$1,523.30
	Yellowfin	47.43	\$168,294.85	18.41	\$67,743.35
	Others	3.43	\$11,889.70	0.41	\$1,302.95
<b>2016 Total</b>		<b>69.54</b>	<b>\$252,668.90</b>	<b>30.63</b>	<b>\$110,780.35</b>
2015	Bigeye	8.35	\$28,776.45	2.09	\$7,285.25
	Black Marlin	0.00	\$0.00	0.00	\$0.00
	Blue Marlin	0.00	\$0.00	0.00	\$0.00
	Pacific Bluefin	0.00	\$0.00	0.00	\$0.00
	Swordfish	0.60	\$2,114.00	0.00	\$0.00
	Yellowfin	16.45	\$57,193.75	6.26	\$21,817.90

Year	Species	Local Sales (mt)	Fish Value (USD)	Donation (mt)	Fish Value (USD)
<b>2015 Total</b>		<b>25.40</b>	<b>\$88,084.20</b>	<b>8.35</b>	<b>\$29,103.15</b>
2014	Bigeye	31.58	\$108,639.75	6.90	\$24,115.60
	Black Marlin	0.00	\$0.00	0.00	\$0.00
	Blue Marlin	0.00	\$0.00	0.13	\$240.50
	Pacific Bluefin	1.92	\$6,734.00	0.00	\$0.00
	Swordfish	0.00	\$0.00	0.00	\$0.00
	Yellowfin	29.90	\$103,587.05	10.65	\$37,210.75
<b>2014 Total</b>		<b>63.41</b>	<b>\$218,960.80</b>	<b>17.68</b>	<b>\$61,566.85</b>

\*Total Average Rate Charge of \$4.50, by company invoice, for local sales and donations is calculated and averaged from rate charges ranging from \$3.00 to \$6.00.

## DATA COLLECTION SYSTEMS

With support from regional and international organizations, namely FFA, PNA, SPC, WCPFC and the FAO, the DOFM has maintained a regular monitoring program. This includes monitoring of locally-based and foreign-based fleets, port sampling to collect landings and unloading data, a vessel licensing database that keeps records of vessel characteristics, observer programs (human and electronic), and vessel monitoring systems.

Palau is currently implementing the latest versions of SPC's regional data forms. The locally-based foreign companies are required by the Division to submit their fishing reports on a monthly basis. The foreign-based Japanese longline and purse seine companies submit their logsheets through email, facsimile, and postal service. The data are reconciled and then entered into the TUFMAN 2 Database.

---

### *Log sheets & Port Sampling - data collection and verification*

---

Dedicated fisheries port samplers and compliance officers are present at all times during offloading operations of longline fishing vessels. Their presence helps ensure that correct forms are used, that they are properly filled out by vessel captains, and that they are submitted to DOFM. Port sampling data is collected during offloading operations to help verify catches reported and to collect biological information.

---

### *Observer data*

---

All observers boarding a fishing vessel are required to complete and submit observer reports a week after their trips. Observer reports are verified by a designated officer and uploaded into TUFMAN2. Observer data are used to verify information collected through captains.

Palau has three observers and in 2017, two fishing trips were monitored by observers on locally based foreign vessels, totalling 16 days.

---

### *Transshipment*

---

The Division designed a form for fishing companies to use when reporting transshipments. All transshipments require prior authorization from the BMR. Once an authorized transshipment is conducted, a mandatory report is submitted to the fisheries officer during offloading operations. Transshipment forms are used to collect data including date, time, and location of transshipment as well as the amount of catch (by species) and its estimated weight.

---

## MONITORING & CONTROL

---

The DOFM has established measures to monitor and control fishing activities in Palau's EEZ. This is to ensure that vessel operators comply with Palau's laws as well as with regional and international treaties and agreements to which Palau is a party. The key monitoring and control measures or activities practiced in Palau among its flagged and licensed vessels are:

- Vessel monitoring system (VMS) or Automatic Location Communicator (ALC)

- Inspection of vessels in port
- Port sampling and monitoring of fish unloading
- National observer program
- Electronic monitoring program & Electronic Report Program
- Reporting requirements

---

*Vessel Monitoring Systems (VMS) & Automatic Location Communicator (ALC)*

---

All fishing vessels permitted to fish in Palau's EEZ are required to install a vessel monitoring system (VMS) for monitoring purposes. VMS provides navigational or positional data, which is used to verify catch position with the catch log reported by the vessel captain (figure 11). An Automated Information System (AIS) is also used to locate and track vessels. Both the VMS and AIS are part of the Automatic Location Communicator (ALC). Within DOFM, one officer is assigned to monitor vessels in Palau EEZ using VMS. On a more frequent basis, officers often liaise with FFA regarding VMS matters.

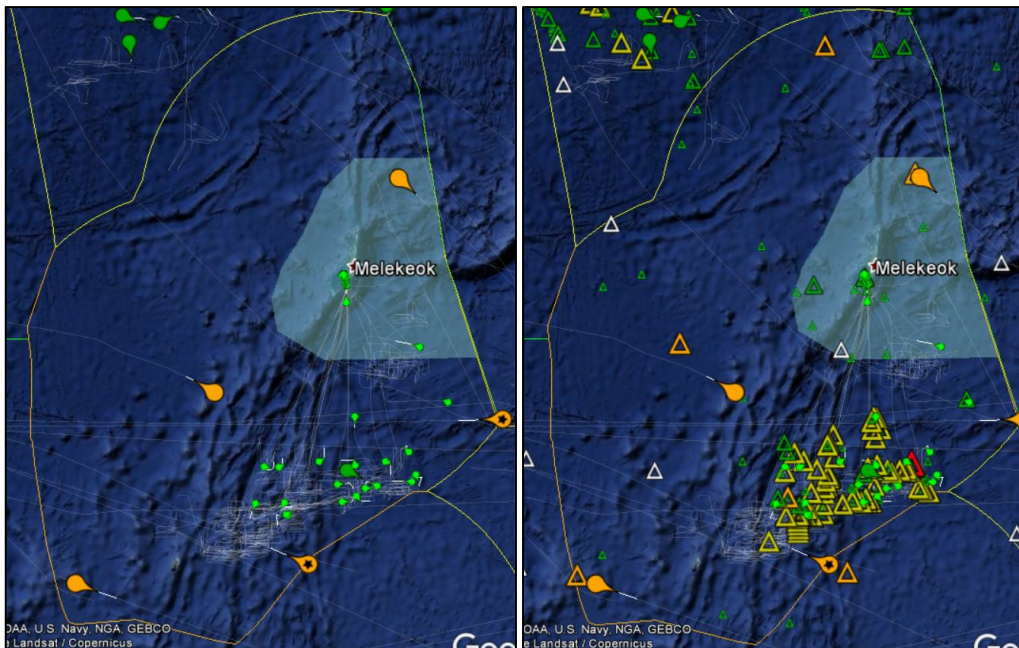

FIGURE 9. VESSELS IN PALAU'S EEZ MONITORED USING VMS (LEFT) AND VMS AND AIS (RIGHT). ORANGE TEARDROPS REPRESENT VESSELS MONITORED BY THE FFA VMS, YELLOW TRIANGLES SIGNAL BUOYS USED BY LONGLINE VESSELS. ALL OTHER TRIANGLES REPRESENT VESSELS TRANSMITTING AIS.

*Electronic Monitoring (EM) & Reporting (ER)*

In the summer of 2016, BMR, in partnership with The Nature Conservancy (TNC) and other stakeholders, piloted an EM project focusing on longline vessels licensed by Palau. Seven Palau licensed fishing vessels were installed with EM systems (table 28). Cameras were placed on board vessels to video record fishing activity. Data from the EM system was then retrieved and analyzed by the Observers at the Data Review Center (DRC).

Two key EM project objectives were to set up in-country EM video review capacity and to have the onboard EM systems collect as much data as possible.

TABLE 26. VESSELS PARTICIPATING IN THE EM PROGRAM, TRIP AND SET STATISTICS AS OF JUNE 19, 2017.

VESSEL	Date EM	Days	% EM System	# trips completed	# sets completed	# trips analysed	# sets analysed
	Installed	installed	Operational	with EM	with EM	at DRC	at DRC
1	9/27/2016	449	27.50%	3	26	2	21
2	10/01/2016	445	70.90%	17	146	4	31
3	10/05/2016	441	74.50%	18	155	4	21
4	10/13/2016	331	50.90%	4	35	0	0
5	1/25/2017	397	80.10%	9	135	1	15
6	1/18/2017	336	49.90%	2	30	0	0
7	1/13/2017	341	64.70%	5	75	0	8
<b>TOTAL</b>				<b>58</b>	<b>602</b>	<b>11 (19%)</b>	<b>96 (16%)</b>

Through this cooperative project, Palau received a technical grant from TNC valued at approximately 136,000 USD in the form of equipment and services (table 29). In addition to financial assistance, BMR personnel were trained on the use of the EM video review software. To date, a total of 11 full trips have been analyzed and successfully uploaded to the SPC TUBs (Tuna Observer System database) by the Palau EM analysts.

TABLE 27. EQUIPMENT AND SERVICES PROVIDED TO PALAU FOR THE EM PROJECT.<sup>1</sup>

Item	Cost
Sea tube camera systems (7)	\$35,870.00
SVM Computer Work Stations (3)	\$6,490.00
Total shipping costs	\$18,756.00
Technician travel and expenses - Trainings and installations	\$30,890.21
Total DRS fees <sup>2</sup>	\$34,188.00
Storage solutions, Synology plus HDD's	\$14,892.81
Satlink discount and credit <sup>3</sup>	-\$5,092.75
<b>Total</b>	<b>\$135,994.27</b>

Results so far are positive, as the footage covers almost the entire part of fishing operations when the EM system is fully functioning and operational. Using this EM system, Office Observers (OOs) were able to record details of gear deployed and fishing activities such as hook counts, float counts, time of set start, time of set end, time of hauling start, and time of hauling stop. EM systems allow OOs to record all catch by species (both target and bycatch species) and measure the length of fish. The result of the analysis also showed other non-compliant activities conducted by vessels operators, such as transfer of catch, transfer of vessel provision, transfer of crews, and dumping of waste (e.g. plastics) at sea. The comparison of SPC/FFA Regional Catch Logsheets shows that vessel operators with EM Systems placed on their vessel record catch more accurately than vessel operators whose vessels are not equipped with EM systems.

<sup>1</sup> TNC-Palau Cooperative Pelagic Longline EM Project (2017) – End of Contract Summary Report (Unpublished)

<sup>2</sup> DRS fees include the first full year along with an extra 6 months under the amended contract

<sup>3</sup> This credit was provided as compensation for delayed arrival of the Satlink EM hardware equipment.



## COMPLIANCE

---

The DOFM is responsible for inspection of fishing vessels that enter the country's only designated port at Malakal (figure 12). In general, the aim of vessel inspections in port is to:

- Ensure fishing vessels are in compliance with the national fisheries laws.
- Ensure enforcement actions are taken against vessel operators that violate fisheries laws of Republic of Palau.
- Promote harmonized practices to ensure implementation of Conservation and Management Measures (CMMs) adopted in the Western and Central Pacific Ocean (WCPO) region.
- Collect fisheries data and statistics through inspection of vessel in port for fisheries management purposes.

The types of inspection undertaken include:

- Pre-fishing inspection, which is conducted on fishing vessels that enters port purposely to collect a Republic of Palau Fishing License.
- Vessel arrival boarding and inspection, which is conducted on licensed vessels that enter the port for offloading and other activities and other unlicensed fishing vessels that enter port for other activities such as pick up of crew.
- Port departure inspection, which is conducted on licensed vessels that depart the port to fishing grounds or other ports.



FIGURE 10. A REPRESENTATIVE (LEFT) OF A LOCALLY-BASED FISHING COMPANY TRANSLATES REPORTING REQUIREMENTS AS EXPLAINED BY FISHERIES OFFICERS FROM THE DIVISION OF OCEANIC FISHERIES MANAGEMENT.

---

## ENFORCEMENT

---

The Division conducts the above-mentioned monitoring activities to ensure that fishing vessels comply with Palau's national laws and the terms of the unilateral agreement (ULA). However, Division staff do not have the authority to cite fishing vessels for any violation. Enforcement is a mandate fulfilled by the Bureau of Marine Law under the Ministry of Justice. Therefore, DOFM and Marine Law coordinate their efforts to ensure proper enforcement and to deter any illegal activities or violations of the fisheries laws of the Republic of Palau.

---

## REGIONAL AND INTERNATIONAL INSTRUMENTS

---

In addition to upholding and implementing relevant national laws regarding pelagic fisheries, the Division is also tasked with ensuring that Palau meets its obligations under the following sub-regional, regional and international agreements and conventions that the Republic is a party to:

1. United Nations Convention on the Law of the Sea (UNCLOS)
2. United Nations Fish Stocks Agreement
3. FAO Code of Conduct

4. Convention on Biological Diversity
5. FAO Compliance Agreement
6. FAO International Plans of Action
7. Port State Measure Convention
8. Driftnet Convention
9. United States Multilateral Treaty
10. Nauru Agreement Concerning Cooperation in the Management of Fisheries of Common Interest
11. The Federated States of Micronesia Agreement (FSMA) for Regional Fisheries Access
12. Palau Arrangement for the Management of the Western Pacific Purse Seine Fishery
13. Niue Agreement on Cooperation in Fisheries Surveillance and Law Enforcement in the South Pacific
14. Parties to the Nauru Agreement (PNA)
15. Forum Fisheries Agency (FFA)
16. FFA Minimum Terms & Conditions
17. Western and Central Pacific Fisheries Convention
18. Secretariat of the Pacific Community (SPC) Convention
19. Convention on International Trade in Endangered Species of Wild Flora and Fauna (CITES)

#### PALAU NATIONAL MARINE SANCTUARY

---

In October 2015, the Palau National Marine Sanctuary Act (PNMSA) was passed by Congress to preserve 80% of Palau's Exclusive Economic Zone as the Palau National Marine Sanctuary. This is designated as a no-take area, with the remaining 20% being established as a Domestic Fishing Zone (beginning at the boundary of the territorial sea and extending outward into Palau's EEZ for an area of approximately 85,896 square kilometers) where only locally-based vessels may operate and from which exports are banned, with the exception of tuna caught in free-schooling purse seine operations. These reforms are being implemented over a period of time that started

in January 2016 and will end on December 31, 2019. The PNMS Transition Regulations were adopted and promulgated to govern fishing during this wind-down period so that by January 1, 2020, the Palau National Marine Sanctuary will be fully implemented.

Pursuant to §123 of the PNMS Act, the Division has the following duties, functions and authority in implementing and maintaining the PNMS<sup>1</sup>:

- a) To adopt regulations for the conservation, management, and utilization of all living resources in the Palau National Marine Sanctuary and the Domestic Fishing Zone of the Republic, including but not limited to: equipment, catch types and species, fishing seasons, quotas and procedures for permits;
- b) To negotiate and conclude foreign fishing agreements in accordance with this title;
- c) To issue fishing permits in accordance with the law and regulations promulgated pursuant to sections 122 and 123 of the PNMS Act;
- d) To monitor fish stocks and set allowable catch limits within the Domestic Fishing Zone at a level necessary to supply the domestic market in Palau;
- e) To monitor all fish harvested within the Domestic Fishing Zone;
- f) To coordinate with the Ministry of Justice for the enforcement of all laws, rules and regulations in relation to domestic fishing, transit by foreign and domestic vessels through Palau's waters, and illegal or unreported or unregulated fishing or illegal activities within the Palau National Marine Sanctuary or Domestic Fishing Zone;
- g) To adopt regulations for the placement of Palau observers aboard all foreign and domestic fishing vessels engaged in fishing within Palau's waters or for Palau's continental shelf resources. Observers, while stationed aboard such fishing vessels, shall carry out such scientific, compliance monitoring, and other

---

<sup>1</sup> Republic of Palau Public Law 9-49 – Palau National Marine Sanctuary Act of 2015, Section 123

functions as the Minister deems necessary to carry out the provisions of this chapter;

- h) To coordinate Palau's compliance with all international fishery agreements or foreign fishing agreements, with a focus on maximizing the returns to Palau under any such agreements and negotiate with parties to such international fishery agreements, such as the Nauru Agreement; and
- i) To perform such other duties and functions as may be necessary to carry out the purposes of this chapter.

As fishing companies and managers look towards a new reality following the full implementation of the PNMS in 2020, including limited landings and fewer participants, they must address important social questions about how to sustain a viable domestic fishery. Palau's locally-based fishing industries are committed to ensuring their viability but the unpredictable price signals and shifting number of fishing vessels pose significant challenges. Other changes, like the winding down of vessel days under the Vessel Day Scheme (VDS) of the Parties to the Nauru Agreement (PNA) in preparation for the full implementation of the PNMS, and a decrease in export commodity prices, have also indirectly affected Palau's fisheries. These challenges pose a great impact on Palau's economy which is highly dependent on tuna as its only export commodity. Realistic resource pricing and recognition of the value of fishery commodities along with new conservation policies could help promote and stabilize Palau's economy.

## CHALLENGES AND OPPORTUNITIES

---

The Division recognizes its limited capacity for scientific analysis on offshore fisheries and places an important priority on capacity building. Currently, it plans to continue to rely on the regional partners such as the Pacific Community (SPC) for stock assessments and other related fishery data analyses. SPC has provided strong support in this area and continues to aid the DOFM in interpreting analysis results and applying them in fisheries management. In addition to stock assessment analysis, SPC provide database support to Palau's offshore fisheries database and at the same time maintains a dedicated webpage resource for accessing commercial fisheries data. Some analysis of data is carried out by the current Data Officers and sent to SPC, but other areas still need improvement to meet the required regional standards.

There are also internal issues that need to be addressed, especially with the Electronic Monitoring program. The EM pilot project faces several challenges, including insufficient staff for data review, lack of technical expertise to fix EM system malfunctions, and tampering with the on-board cameras by vessel captains. Staff shortages result in delays in data entry (tuna fishery) and analysis (EM program), as well as dissatisfied partner organizations and an overall lack of program support.

To support the Oceanic Fishery Management Division's work, we suggest the inclusion of oceanic fisheries into the BMR Strategic Plan.

## DIVISION OF INFORMATION AND DATA MANAGEMENT

---

The Division of Information and Data Management is tasked with the responsibility of developing, managing, and maintaining an efficient information and data management system. The Division is an initiative of the Bureau to strengthen its information and data management systems through the following core activities:

- Develop and input data into databases;
- Manage and analyze all marine resources data collected by the Bureau;
- Produce reports on the status of coastal marine resources and aquaculture, including an annual report each year for the Bureau; and
- Develop and disseminate educational and outreach materials in collaboration with states, partners and stakeholders to meet identified needs.

At the time of publication, none of the positions within this Division were filled; as such, the Division is not operational. Nevertheless, a number of staff from other Divisions were fulfilling some of the duties and responsibilities of the vacant positions.

## FISHERIES REGULATIONS AND POLICY

---

TABLE 28. A SUMMARY OF NATIONAL FISHERIES POLICIES SINCE 1994.

RPPL No.	Title	Description	Passed	Approved
4-18	Marine Protection Act of 1994	To regulate the taking of certain species of marine and terrestrial organisms, to prohibit or limit certain fishing methods, to repeal RPPL No. 1-9, RPPL No. 3-61, and for other purposes.	04/18/94	05/18/94
4-35	To amend RPPL No. 4-18	Regarding the taking of certain species of marine and terrestrial organisms, to clarify and strengthen the penalties and enforcement provisions, to require the	05/03/95	05/17/95

RPPL No.	Title	Description	Passed	Approved
		Minister to promulgate regulations concerning cultured species, and for other purposes.		
7-18	Amendment of 27 PNC Chapter 12	To amend 27 PNC 1203, 1204, 1205, and 1206 to clarify that prohibitions of the Marine Protection Act apply to activities that take place anywhere within the Republic of Palau and to make possession and receipt violation of the Act; to amend 27 PNC 1209 to provide for maximum criminal penalties for violation of the Act; to amend 27 PNC 1210 to provide for civil penalties for all the persons who participate in the violation of the Act in any way; and for other purposes.	04/25/06	05/03/06
7-43	To amend 2 PNC, Chapter 1, Sections 102, and 106	To split the Ministry of Resources and Development, by creating two separate and distinct ministries; to dissolve the Ministry of Commerce and Trade; and for other related purposes.	05/01/08	05/08/08
7-44	To amend Title 27 of the PNC, Sections 1203, 1204, and 1209	Prohibitions and Criminal Penalties	05/02/08	05/08/08
8-23	To amend 24 PNC Section 1281	To impose a five-year moratorium on the taking of hawksbill turtles; and to impose greater penalties for the violation of the Act; and for other related purposes	12/22/10	12/29/10
8-44	To amend 27 PNC Section 1204 and Section 1207	To allow the cultivation of certain species of crab, and for other related purposes	05/03/12	05/30/12



RPPL No.	Title	Description	Passed	Approved
9-50	Export Control	To control the export of any living resources that primarily inhabits the reefs of Palau, and for other related purposes	10/15/15	10/30/15
9-52	To amend 24 PNC Section 1281	To prohibit the taking or intentional killing of hawksbill turtles until April 01, 2021, and for other related purposes	11/04/15	11/11/15
Title 27	Fishing Division 1, Foreign Fishing	Fishery Zones and Regulations on Foreign Fishing	Sources RPPL 4-18	Modified Sec. 11
Regulation	BMR Regulations	Response to RPPL 4-35, which required the Minister to promulgate regulations		01/06/05
Regulation	Emergency Regulations	Prohibiting the exportation of sea cucumbers		12/28/11
Regulation	Domestic Law	Palau Domestic Fishing Laws		2012
Regulation	Giant Clam Revolving Fund	Marine Export Declaration fees, CITES Application fees, and charges collected from clam seedlings distributed in support of the clam farming industry		06/25/14

#### TECHNICAL REPORTS AND PUBLICATIONS BY BMR 2014- 2017

The Bureau published six technical reports between 2014 and 2017, listed in Appendix III.

#### CHALLENGES AND OPPORTUNITIES

The main issue for the division of information and management is a lack of staff. Tasks are only partly fulfilled by staff that are formally working in administration, or by contract staff, but no one is formally assigned to key roles. For example, the Annual Report falls under the responsibilities of this Division. To ensure that the recurring annual publication of a report for the Bureau is maintained, a staff member needs to be assigned to deal with the logistics and organization of compiling and publishing the report. Another area in need of improvement is the BMR library. The

library needs dedicated attention for both its digital and physical components by a staff member that does not already have a full-time workload, but there is currently no one to take this on.

## CONSTRAINTS OF THE BUREAU

---

During the period under review, the endeavors of the Bureau have been impeded by certain limitations. Limited financial resources have obstructed the Bureau's ability to allocate much needed funding to core operations and, subsequently, have impacted the overall performance of the Bureau and its capacity. Additionally, financial constraints have contributed to inadequate facilities which are deficient in working space and equipment and have unresolved maintenance issues. By bringing these constraints to light, we hope to address and mitigate them.

A lack of expertise in key areas, coupled with a dearth of capacity building within the Bureau, has undermined its successes over the years. The Bureau has limited operational capacity and a shortage of skilled human resources. We are grateful for the periodic training from our development partners - the Pacific Community (SPC), The Nature Conservancy (TNC) and the Japanese and Taiwanese Governments – but we require additional technical expertise to assist us in recommending legislation and drafting regulations to protect Palau's valuable marine resources. The Bureau has also struggled with fisheries data management, including data collection, storage, quality control and analysis, and would greatly benefit from additional technical expertise in this area. Additionally, the Bureau would gain from increased public awareness on key fisheries issues and initiatives taken to address such issues. For example, publishing more frequent Domestic Fishing Laws and clarifying the rationale and research behind such regulations to the public will likely result in increased compliance.

Vacancies in core positions, such as middle management (i.e. the Chief positions), and the absence of capacity building for existing personnel, have also resulted in poor performance assessments in the Bureau. The absence of middle management has created an environment without leadership or direction, and little accountability for failure to reach goals. The result has been dwindling motivation and morale and low productivity from some staff members. Currently, there are no operational protocols or mandated reporting methods in place and no existing internal processes to incentivize strong work ethics or create accountability for not achieving targets. There are also no defined or perceptible career paths for staff members and some are underpaid or work unpaid overtime. Hiring middle management with solid leadership skills and expertise in core areas, building capacity in existing staff, and developing operational protocols and procedures will empower the Bureau to promote effective governance and transparency while improving productivity and morale.

Another important issue faced by the Bureau is the largely outdated, piecemeal legal framework encompassing fisheries management which continues to hinder policy goals. At present, fisheries policies and legislation exist in several different laws, regulations, and executive orders, which creates disconnect and confusion between the agencies responsible for implementation. To confront this issue, an updated comprehensive National Fisheries Policy, and supporting legislation, should be developed and implemented with the cooperation of the Ministry of Natural Resources, Environment and Tourism and the Palau Fisheries Advisory Committee.

By elucidating the constraints that the Bureau has faced since the last annual report in 1992, we hope it is clear that by correcting the absence of financial and technical resources with which we have been challenged, the Bureau's mission is attainable. In the interim, the Bureau will continue to streamline its policies, priorities and management to achieve our goals to the best of our ability with the resources available to us at this time.

## APPENDIX I

TABLE 29. PARTICIPATION OF BMR STAFF IN WORKSHOPS, MEETINGS AND TRAININGS IN 2017.

No	Name of Training/Workshop	Attendees	Duration	Host & Funding	Location
1	R Workshop	Oceanic Division staff	6-10 Feb, 2017	PNA	BMR. Palau
2	3 <sup>rd</sup> Meeting of Signatories to the Dugong MOU	Percy Rechelluul	13-14 March 2017	CMS/UNEP	Abu Dhabi, United Arab Emirates.
3	Training on Aquatic Biosecurity Planning	Helena Rebelkuul Percy Rechelluul	24-28 April, 2017	SPC	New Caledonia
4	Tuna workshop	Zilah Oiterong	24-28 April 2017	SPC	New Caledonia
5	CITES Pacific Workshop on Non-Detriment Findings for CITES Appendix II Sharks and Rays	Scherryl L. Solang & Percy Rechelluul	May 26 – June 4, 2017	New Zealand Government	Nadi, Fiji
6	To attend the study visit on Development of Aquaculture and Food Processing for food security based of the Philosophy of Sufficiency Economy	Percy Rechelluul	June 2017	Local Funding	Bangkok, Thailand
7	Small Scale Canning Workshop	Fishermen & related agencies	3-7 July, 2017	BMR, PNAO, NRFC	Palau

8	Fisheries Information Management System (FIMS)	Everson Sengebau	21-29 Oct. 2017	PEW	Brisbane, Australia
9	Aquaculture and Blue Growth Development Opportunities in Small Island Development States (SIDS)	Percy Rechelluul	22-29 Oct. 2017	FAO	Rome, FAO Conference
10	25 <sup>th</sup> OFCF Head of Fisheries Meeting, Final Arrangement	Leon E. Remengesau	21 Oct. – 01 Nov., 2017	OFCF	Suva, Fiji
11	Management options consultation (MOC) and special officials (FFC100)	Kathleen Sisior	25 Oct. – 5 Nov., 2017	FFA	Honiara, Solomon Islands
12	Seafood Safety and Fish Handling	Scherryl L. Solang, Percy Rechelluul, Lora Demei, Erbai Yukiwo, Roman Mongami	Oct, 28 – Nov., 7, 2017	TNC & SPC	Palau
13	To Scope the Development Potential for Sport Fishing Tourism in Kayangel	Scherryl L. Solang, Percy Rechelluul, Lora Demei, Erbai Yukiwo, Roman Mongami	7-15 Nov., 2017	SPC	Palau
14	First SPC Regional Technical Meeting on Coastal Fisheries	Percy Rechelluul Scherryl L. Solang	28 Nov. – 01 Dec., 2017	SPC	Noumea, New Caledonia

## APPENDIX II

---

### EXAMPLES OF PROJECTS UNDERTAKEN IN 2017 BY PARTNER ORGANIZATIONS IN PALAU

---

#### *Improving marine resources management in Palau through ecosystem-based fisheries management: fisheries-dependent monitoring of commercial reef fisheries*

---

**Partners:** University of Guam (UoG), Palau International Coral Reef Center (PICRC) & Bureau of Marine Resources

#### **Summary**

This project supports and enhances fisheries management needs in Palau (and the wider Micronesia region) by providing quantitative fisheries-dependent baselines to assess the status of targeted reef-fish populations. Previous fisheries-dependent studies in the main commercial markets of Palau have been intermittent, surveying either a few months within a year, one day within each week across the year, or a subset of species in the Ngarchelong State fishery in Northern Babeldaob. While clearly useful for generalizing fisheries and providing site-specific insight for northern Palau, a robust analysis of Palau's overall coral reef fishery is lacking. Questions requiring further investigation include:

- (i) The dependence of catch success upon seasonal and lunar cycles,
- (ii) The distribution of fishing pressure across Palau,
- (iii) Species-based responses to fishing pressure, and
- (iv) Links between fishing pressure and the ecological condition of reefs.

From November 2016 to November 2017, we collected comprehensive information regarding commercial reef-fish landings through a combination of fisher interviews and daily species-based landings at the main fish markets of Koror. Following methods developed by the principal investigators, the fisheries-dependent assessments were also put into practice across several Micronesian jurisdictions.

During daily market visits by PICRC and BMR personnel, 287 fisher interviews were conducted. Coupling these interviews, over 23,000 fish were measured and identified at species level using stereo-video tools. In addition, records of daily landings from individual fishers were recorded, totaling over 1,199 landing and 186,000 pounds of fish. The resulting databases, together with available fisheries-independent databases, will be critical to balance Palau's reef fish landings with ecological sustainability, ultimately supporting their productive tourism industry as well.

---

*FAO Assistance for the establishment of the Micronesian Association for Sustainable Aquaculture (MASA) 2014-2017*

---

**Partners:** FAO, BMR

### **Summary**

The MASA project began in 2014 and ended in 2017. During the 2nd regional project workshop, held in Guam in May 2014, participants recommended that MASA be included in the agenda of the Micronesian President Summit (MPS). With the help of focal points of the project in RMI (hosts of the 2015 MPS), MASA was included in the agenda. The Presidents endorsed the official formation of MASA in their communiqué and also considered that a High Level Official Meeting (HLOM) be held in Palau on Nov 23-25, 2015. The members -RMI, FSM, Nauru, and Palau- meet every three years. The Republic of Nauru does not participate in the MPS but is one of four governments that requested that the FAO provide technical assistance to establish MASA and participate in the Project TCP/SAP 3403 (the first inaugural meeting convened immediately after signing the MASA Agreement on Nov, 25, 2015, thereby creating the Association). Elected Chairperson and Vice Chairperson of the Association are Minister F. Umiich Sengebau of MNRET, and Mr. Peter Diema, member of the Board of Directors of the Nauru Fisheries and Marine Resources Authority, respectively. The HLOM adopted administrative instruments: Rules of Procedure and Financial Regulations. After the Three-Year Technical Work Program of MASA was adopted, a HQ Agreement was adopted subject to further negotiations between the Association and the host Government (Palau). The coordinating office is



located on the second floor of the BMR building, which has also served as the PNMS's temporary office space, and is supported by staff from MNRET.

---

*Estimating size at maturity using length measurements from spawning aggregations and deriving 20% SPR size limits for at least five reef fish species*

---

**Partners:** CRRF, Biospherics (Australia)

### **Summary**

A new length-based spawning potential ratio (LB-SPR) data-poor assessment technique was developed to assess the sustainability of coral reef fisheries and to guide stocks towards management reference points. However, the SPR calculation process requires estimates of the size at maturity of each species in each location so that assessments and size limits can be scaled to local growth conditions. This project aims to address data gaps for seven species of reef fish in Palau. Five of these species have no current size at maturity estimates and two more have an estimated size at maturity from previous visual gonad inspections in the Northern Reefs (*Lethrinus olivaceus* and *Lutjanus bohar*). These latter two species were chosen for additional study due to the importance of their spawning aggregations. The study also investigated how data collected from non-invasive underwater stereo-video of fish spawning aggregations compared to fish dissections. These new measurements of size at maturity from microscopic histology will provide a basis to set new minimum size limits and to conduct future stock assessments for important fishery species in Palau.

## APPENDIX III

### DATA AND INFORMATION REFERENCED IN THE REPORT

A LIST OF THE GENERAL EQUIPMENT CURRENTLY MANAGED BY BMR AND ITS DIVISIONS.

No.	Description	Quantity	Fund Source	Division	Condition
<i>Administration</i>					
1	Telephone System, The Norstar Modular Integrate - Communication	1	ROP	ADM.	Good condition
2	Water Proof Camera	1	NGCLAM	ADM.	Good condition
3	Laptop	5	NGCLAM	ADM.	Fair to good condition
4	Desktop Computers	4	ROP, TNC	ADM.	All desktop computers are in good condition
5	Printer	6	ROP	ADM	All printers are in good to fair conditions
6	Air conditioner	1	ROP	ADM	Good condition
<i>Division of Aquaculture &amp; Fisheries Development (DAFD)</i>					
1	Desktop Computers	2	ROP	DAFD / PMDC	Fair require services and upgrade
2	Printer	2	ROP, OFCF	DAFD / FinFish	Printers are in fair condition and requires services
3	Air Conditioner	1	ROP	DAFD / PMDC	Good condition
4	Vehicle	5	OFCF, FAO	DAFD / PMDC	Good to fair conditions and require routine services and maintenance

No.	Description	Quantity	Fund Source	Division	Condition
5	Boat	2	OFCF	DAFD / Shop	Good condition
6	Boat Engine	5	OFCF	DAFD / Shop	Two are in good condition and require routine service and maintenance; 3 are in poor condition and ready to be surveyed
7	Water Blower	1	OFCF	DAFD / PMDC	Poor – Needs to be surveyed
8	Water pump	2	OFCF	DAFD / Shop	Poor - Needs to be surveyed
9	Green Machine (Grass trimmer)	2	NGCLAM	DAFD / Shop	1 new and in good condition and 1 surveyed
<i>Division of Coastal Fishery Management (DCFM)</i>					
1	Server	1	SPC	ADM.	Good condition
2	Desktop Computers	6	SPC, ROP	DCFM	Fair Condition
3	Laptops	1	TNC	DCFM	Fair Condition
4	Monitor	1	ROP	DCFM	Good Condition
5	Printer	5	SPC, ROP	DCFM	2 in fair condition, 3 in poor condition
6	Copy Machine	1	Turtle Proj. - USFWL and JICA	DCFM	Poor- Needs to be surveyed
7	Vehicle	2	Turtle Proj. - USFWL and JICA	DCFM	Fair condition and require engine services and body repair
<i>Division of Oceanic Fishery Management (DOFM)</i>					
1	Desktop Computer	8	TNC, FFA, ROP	DOFM	1 mission, 2 in poor condition, 5 in good condition
2	Printer	1	FFA, ROP	DOFM	Good Condition

No.	Description	Quantity	Fund Source	Division	Condition
3	Scanner	1	FFA	DOFM	Good Condition
4	Server	1	FFA	DOFM	Good Condition

CITES PERMITS ISSUED IN 2017, LISTED BY DESTINATION COUNTRY.

Number of Permits	Species	Quantity	Destination
1	<i>Tridacna crocea</i>	70	Australia
	<i>Tridacna derasa</i>	70	
	<i>Hippopus hippopus</i>	5	
	<i>Tridacna maxima</i>	70	
1	<i>Tridacna crocea</i>	240	Austria
	<i>Hippopus hippopus</i>	20	
24	<i>Tridacna crocea</i>	635	China
	<i>Tridacna derasa</i>	1878	
	<i>Hippopus hippopus</i>	46.5	
	<i>Nautilus Belauensis</i>	1	
	<i>Tridacna squamosa</i>	5	
8	<i>Hippopus hippopus</i>	215	CNMI
1	<i>Tridacna squamosa</i>	1	Croatia
	<i>Tridacna derasa</i>	2	
1	<i>Tridacna crocea</i>	100	England
	<i>Tridacna derasa</i>	40	
2	<i>Tridacna derasa</i>	20	FSM
	<i>Tridacna derasa</i>	21	
8	<i>Tridacna crocea</i>	1198	Germany
	<i>Tridacna derasa</i>	297	
	<i>Hippopus hippopus</i>	135	
	<i>Tridacna maxima</i>	424	
	<i>Tridacna squamosa</i>	185	
1	<i>Hippopus hippopus</i>	2	Greece
20	<i>Tridacna derasa</i>	52.5	Guam
	<i>Hippopus hippopus</i>	148.5	
67	<i>Acropora</i>	596	USA
	<i>Acropora Tenella</i>	2	
	<i>Anacropora Sp.</i>	1	
	<i>Antipath Elegans</i>	1	
	<i>Antipathes Abies</i>	1	
	<i>Antipathes Bifaria</i>	1	
	<i>Antipathes Elegans Cf.</i>	2	
	<i>Antipathes N. Sp.</i>	2	

Number of Permits	Species	Quantity	Destination
	<i>Antipathes Sp.</i>	14	
	<i>Antipathes Spinulosa</i>	1	
	<i>Aphanipathes Reticulata Cf.</i>	4	
	<i>Aphanipathes Sp.</i>	7	
	<i>Aropora Tenella</i>	3	
	<i>Asteriopathes P.</i>	7	
	<i>Asteriopathes Sp.</i>	1	
	<i>Bathypathes Sp.</i>	1	
	<i>Caryophyllia Sp.</i>	31	
	<i>Caulastrea Sp.</i>	6	
	<i>Cirrhopathes Anguina Cf</i>	2	
	<i>Cirrhopathes Sp.</i>	6	
	<i>Cladopsammia Sp.</i>	1	
	<i>Corallium Sp.</i>	2	
	<i>Tridacna crocea</i>	1682	
	<i>Culicia Sp.</i>	25	
	<i>Cycloceris Sp.</i>	2	
	<i>Cynarina Sp.</i>	30	
	<i>Dactylortochus Sp.</i>	4	
	<i>Dendrophyllia Sp.</i>	5	
	<i>Dendrophyllia Velta</i>	1	
	<i>Tridacna derasa</i>	2982	
	<i>Desmophyllum Sp.</i>	5	
	<i>Distichopora Borenlis</i>	1	
	<i>Distichopora Irregularis</i>	5	
	<i>Distichopora Sp.</i>	14	
	<i>Enallopsammia Sp.</i>	2	
	<i>Eyphyllia Sp.</i>	2	
	<i>Fungia Sp.</i>	4	
	<i>Galaxea Sp.</i>	1	
	<i>Tridacna gigas</i>	2	
	<i>Goniastrea</i>	374	
	<i>Goniopora Sp.</i>	9	
	<i>Heliopora Sp.</i>	2	
	<i>Heteropsammia Cochlea</i>	13	
	<i>Heteropsammia Sp.</i>	24	
	<i>Hippopus hippopus</i>	580.5	
	<i>Javania Sp.</i>	6	

Number of Permits	Species	Quantity	Destination
	<i>Leptoseris Gardineri</i>	7	
	<i>Leptoseris Sp.</i>	5	
	<i>Lillipathes Sp.</i>	1	
	<i>Lobopyllia Sp.</i>	2	
	<i>Madracis Asanoi</i>	4	
	<i>Madracis Sp.</i>	1	
	<i>Madracis Sp.</i>	1	
	<i>Tridacna maxima</i>	748	
	<i>Montipora</i>	25	
	<i>Myriopathes Japonica</i>	1	
	<i>Myriopathes Sp.</i>	3	
	<i>Nautilus belauensis</i>	2	
	<i>Tridacna noae</i>	12	
	<i>Pachyseries</i>	84	
	<i>Pachyseries Rugosa</i>	262	
	<i>Paracyathus Sp.</i>	4	
	<i>Parantipathes Sp.</i>	10	
	<i>Pocillopora Meandrina</i>	25	
	<i>Pocillopora Sp.</i>	205	
	<i>Pocillopora Vernicosa</i>	2	
	<i>Porites</i>	83	
	<i>Porites Rus</i>	467	
	<i>Porities Lobata</i>	50	
	<i>Psammacora Sp.</i>	5	
	<i>Pteriodpathes Sp.</i>	8	
	<i>Rhipidopathes Sp.</i>	1	
	<i>Rhizopsammia Sp.</i>	31	
	<i>Rhizotrochus Sp.</i>	1	
	<i>Seriatopora Sp.</i>	2	
	<i>Tridacna squamosa</i>	503	
	<i>Stichopathes Sp.</i>	5	
	<i>Stylaster Campylecus</i>	1	
	<i>Stylaster Sp.</i>	22	
	<i>Stylaster Tenisonwoodsi</i>	2	
	<i>Stylophora Pistillata</i>	31	
	<i>Stylophora Sp.</i>	1	
	<i>Tubastraea Sp.</i>	115	
	<i>Tubipora Sp.</i>	1	
	<i>Turbinaria Renformis</i>	25	

Number of Permits	Species	Quantity	Destination
	<i>Turbinaria Sp.</i>	5	
1	<i>Tridacna crocea</i>	2	Italy
	<i>Tridacna derasa</i>	4	
	<i>Hippopus hippopus</i>	7	
15	<i>Coral (Unknown)</i>	850	Japan
	<i>Dacropora Digitifera</i>	6	
	<i>Tridacna derasa</i>	0.5	
	<i>Hippopus hippopus</i>	23	
	<i>Nautilus Belauensis</i>	13	
	<i>Pocillopora Damicornis</i>	287	
	<i>Pocillopora Sp.</i>	162	
	<i>Porites Cylindrica</i>	622	
	<i>Tridacna squamosa</i>	2	
	<i>Turisiops Truncates</i>	25	
1	<i>Hippopus hippopus</i>	1	London
3	<i>Tridacna derasa</i>	5	Philippines
	<i>Hippopus hippopus</i>	7	
	<i>Tridacna gigas</i>	1	
2	<i>Tridacna crocea</i>	75	Singapore
	<i>Tridacna derasa</i>	105	
	<i>Hippopus hippopus</i>	25	
	<i>Tridacna maxima</i>	75	
	<i>Tridacna squamosa</i>	50	

Bureau of Marine Resources  
Ministry of Natural Resources, Environment and Tourism  
Republic of Palau



*Koror, Palau  
March 2019*

