

OCS STUDY
MMS 87-0051
CONTRACT NO. 14-12-0001-30064

STUDY OF BIOLOGICAL PROCESSES ON THE U.S. NORTH ATLANTIC SLOPE AND RISE

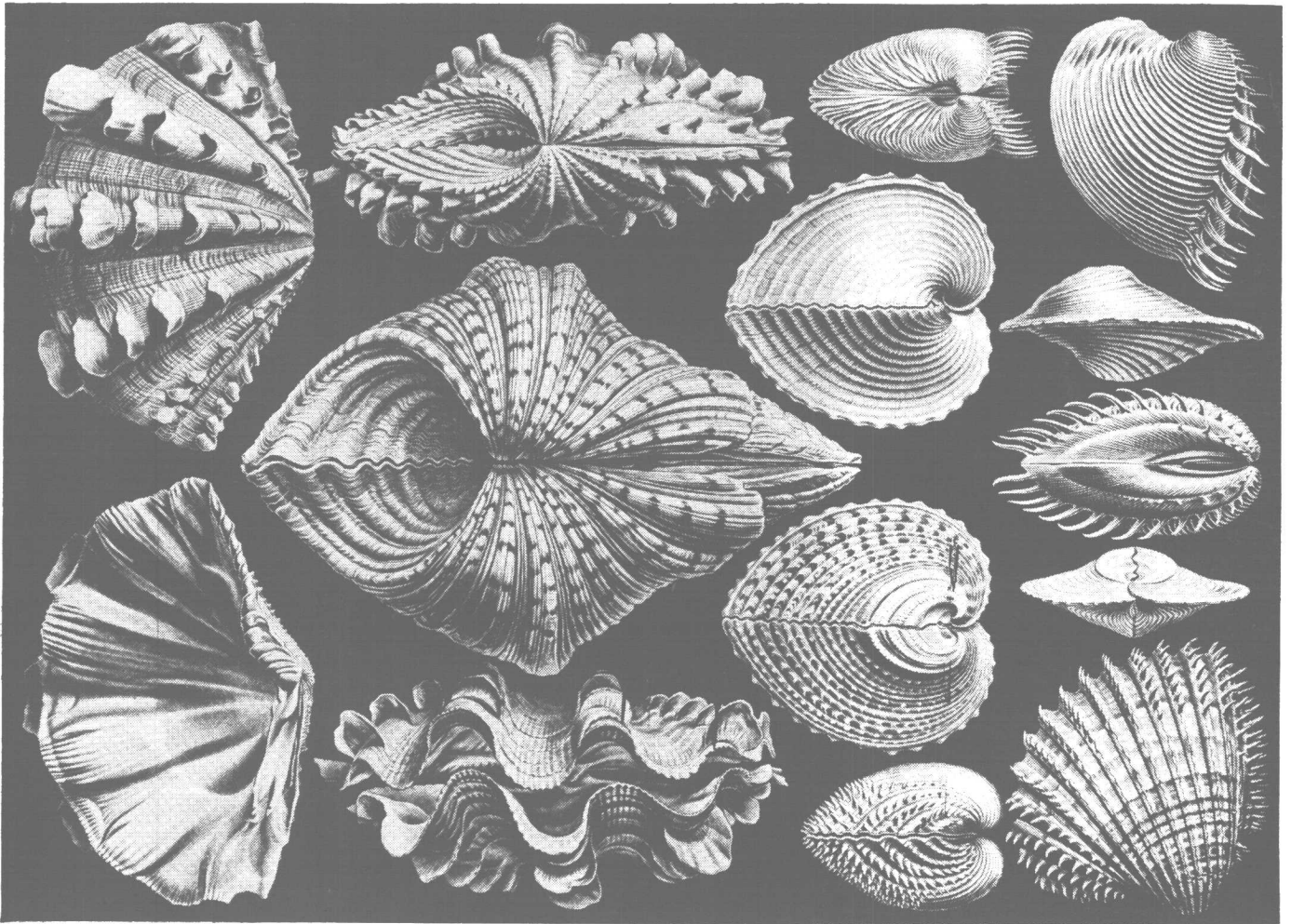

VOLUME 1
EXECUTIVE SUMMARY
PREPARED FOR
U.S. DEPARTMENT OF THE INTERIOR
MINERALS MANAGEMENT SERVICE

OCS Study
MMS 87-0051
Contract No. 14-12-0001-30064

**STUDY OF BIOLOGICAL PROCESSES
ON THE
U.S. NORTH ATLANTIC SLOPE AND RISE**

by

**N. Maciolek¹, J.F. Grassle², B. Hecker³, B. Brown¹, J.A. Blake¹
P.D. Boehm¹, R. Petrecca², S. Duffy¹, E. Baptiste¹, and R.E. Ruff¹**

December 15, 1987

**¹ Battelle Ocean Sciences
397 Washington Street, Duxbury, Massachusetts 02332**

**² Woods Hole Oceanographic Institution
Woods Hole, Massachusetts 02543**

**³ Lamont-Doherty Geological Observatory
of Columbia University
Palisades, New York 10964**

**Executive Summary Prepared for the
U.S. Department of the Interior
Minerals Management Service
Washington, D.C. 20240**

DISCLAIMER

This report is a work prepared for the United States by Battelle. In no event shall either the United States or Battelle have any responsibility or liability for any consequences of any use, misuse, inability to use, or reliance upon the information contained herein, nor does either warrant or otherwise represent in any way the accuracy, adequacy, efficacy, or applicability of the contents hereof.

REPORT DOCUMENTATION PAGE	1. REPORT NO.	2.	3. Recipient's Accession No.
4. Title and Subtitle Study of Biological Processes on the U.S. Mid-Atlantic Slope and Rise		5. Report Date December 15, 1987	
7. Author(s) N. Maciolek, J.F. Grassle, B. Hecker, P.D. Boehm, B. Brown, B. Dade, W.G. Steinhauer, E. Baptiste, R.F. Ruff, R. Petrecca		8. Performing Organization Report No.	
9. Performing Organization Name and Address Battelle Ocean Sciences 397 Washington Street, Duxbury, MA 02332 and Woods Hole Oceanographic Institution, Woods Hole, MA and Lamont-Doherty Geophysical Observatory, Palisades, NY		10. Project/Task/Work Unit No.	
		11. Contract(G) or Grant(G) No. (C) 14-12-001-30064 (G)	
12. Sponsoring Organization Name and Address U.S. Department of the Interior Minerals Management Service Atlantic Outer Continental Shelf Region 1951 Kidwell Drive, Suite 601, Vienna VA 22180		13. Type of Report & Period Covered Executive Summary 3/84-3/86	
13. Supplementary Notes This report is in two volumes: Volume 1: Executive Summary		Volume 2: Final Report	
16. Abstract (Limit: 200 words) Box core samples were collected at 14 stations as part of a monitoring program to evaluate potential effects of exploratory drilling in water depths of 1500 and 2100 m. The box core samples were analyzed for benthic infauna, hydrocarbons, sediment grain size, and total organic carbon, hydrogen, and nitrogen. Benthic infaunal diversity was high at all stations on all sampling dates. As a group, the shallower (1515-1613 m) stations were more diverse than the deeper stations. Species composition and abundance was homogeneous at depths of 2020 to 2195 m along a 176-km transect. Changes in diversity or similarity among stations over time could be explained by changes in the densities of a few dominant species, and were often related to differences in sediment texture, rather than drilling activities. Transect and classification analysis of epifaunal data collected from photographs taken on camera-sled tows indicated trends in trophic structure and species composition that were related to a combination of depth and topography. In one area down-slope of the drill site, a change in the density of a species of sea pen may have been due to drilling activities; however, sedimentary changes not related to drilling may have caused the observed decrease in the abundance of this species. There was no evidence that hydrocarbons in the sediments, or hydrocarbons and metals in brittle stars and sea urchins, originated from sources associated with drilling activities.			
17. Document Analysis a. Descriptors			
b. Identifiers/Open-Ended Terms			
c. COSATI Field/Group			
18. Availability Statement		19. Security Class (This Report)	21. No. of Pages
		20. Security Class (This Page)	22. Price

TABLE OF CONTENTS

	<u>Page</u>
VOLUME 1: EXECUTIVE SUMMARY	
INTRODUCTION.....	1
FIELD PROGRAM.....	2
Box Core Sampling.....	7
Camera Transects.....	7
Recolonization Trays.....	9
Bottom Trawls.....	9
Hydrographic Measurements.....	9
BIOLOGICAL PROCESSES.....	10
Benthic Infaunal Community Structure.....	10
Biomass.....	20
Benthic Recolonization Experiments.....	25
Epifauna.....	26
CHEMICAL COMPOSITION OF SEDIMENTS, AND TISSUES.....	31
Sediments.....	31
Tissues.....	33
Total Organic Carbon, Hydrogen, and Nitrogen.....	33
Sediment Grain Size.....	34
IMPACTS OF DRILLING.....	35
Physical Impacts.....	35
Chemical Impacts.....	36
Biological Impacts.....	38
LITERATURE CITED.....	42

LIST OF TABLES

Table 1.	Sampling Schedule for U.S. Mid-Atlantic Monitoring Program.....	3
Table 2.	Station Reference Coordinates for the U.S. Mid-Atlantic Slope and Rise Study.....	5
Table 3.	Summary of Samples Collected and Analyzed for the U.S. Mid-Atlantic Monitoring Program.....	6
Table 4.	Taxonomic Composition of Species Identified from U.S. Mid-Atlantic Infaunal Samples.....	12
Table 5.	Dominant Species Recorded at U.S. Mid-Atlantic Stations, Presented for Stations Summed According to Depth Intervals	14
Table 6.	Changes Over Time in Hurlbert Rarefaction Values for Species Per 100 and 1000 Individuals and in Shannon-Wiener Diversity (H') at the Drill-Site Stations 1 and 14 and Stations Located 2 km to the Southwest.....	39

LIST OF FIGURES

Figure 1.	Station Locations on the Continental Slope and Rise for the U.S. Mid-Atlantic Monitoring Program.....	4
Figure 2.	Photographic Coverage from Nine Camera-Sled Tows in the Vicinity of the Block 372 Drill Site.....	8
Figure 3.	Rarefaction Curves for Total Fauna, Polychaeta, Peracarida, and Mollusca at U.S. Mid-Atlantic Stations 1-7, 9, and 10	16
Figure 4.	Rarefaction Curves for Total Fauna, Polychaeta, Peracarida, and Mollusca at U.S. Mid-Atlantic Stations 10 through 14	17
Figure 5.	Summed Replicates Collected at Each Station Between April 1984 and November 1985 (Cruises Mid-1 Through Mid-6) Clustered by NESS at 200 Individuals and Group Average Sorting.....	19
Figure 6.	The Upper Curve is a Computer-Generated Species-Area Plot of the Mean Number of Species for Each Combination of Samples from the 2100-m Stations 1-5, 7, and 9 Regardless of Sampling Date.....	21
Figure 7.	Average Wet, Dry, and Ash-Free Dry Weights (AFDW) (g/m ²) For Each Size Fraction at Stations 6 and 10 from Cruise Mid-5.....	23
Figure 8.	Average Ash-Free Dry Weight (AFDW) (mg/m ²) for Taxonomic Categories in Each Size Fraction at Stations 6 and 10.....	24
Figure 9.	Density of Total Megafauna and Five Selected Species With Depth.....	27
Figure 10.	Depth, Trophic Type, and Abundance of Total Megafauna and Five Selected Species from the Camera-Sled Tow Along the 44-km Transect in April-May 1984.....	28
Figure 11.	Hierarchical Classification of Sample Areas from Camera-Sled Tows Along the 44-km Transect.....	30
Figure 12.	Representative UV/F Spectra of Sediment, Drilling Mud, and Drill Cutting Samples.....	32

TABLE OF CONTENTS (Continued)

	<u>Page</u>
VOLUME 2: FINAL REPORT	
CHAPTER 1. INTRODUCTION	1
CHAPTER 2. FIELD PROGRAM	7
CHAPTER 3. BENTHIC INFAUNAL COMMUNITY STRUCTURE	21
CHAPTER 4. BIOMASS ANALYSIS OF INFAUNAL BENTHOS	93
CHAPTER 5. BENTHIC RECOLONIZATION EXPERIMENTS	109
CHAPTER 6. EPIFAUNA	123
CHAPTER 7. CHEMICAL ANALYSIS OF SEDIMENTS, TISSUES, AND DRILLING DISCHARGES	157
CHAPTER 8. SEDIMENT CHARACTERISTICS: GRAIN SIZE AND CHN	205
CHAPTER 9. HYDROGRAPHY	263
CHAPTER 10. DISCUSSION OF BIOLOGICAL PROCESSES ON THE U.S. MID- ATLANTIC CONTINENTAL SLOPE AND RISE	273
CHAPTER 11. IMPACTS OF DRILLING	287
ACKNOWLEDGEMENTS.....	293
LITERATURE CITED.....	297
APPENDICES	
Appendix A. Designation of Subcores in Box Core Samples.....	A-1
Appendix B. Positions of Replicate Box Cores at Each Station.....	B-1
Appendix C. Latitude/Longitude Positions and Loran Time Delays OF Box Cores.....	C-1
Appendix D. Species Recorded from U.S. Mid-Atlantic Slope and Rise Infaunal Samples.....	D-1
Appendix E. Dominant Species at Each Station (Cruises Summed).....	E-1
Appendix F. Dominant Species at Each Station (Cruises Separate).....	F-1
Appendix G. Benthic Community Parameters Calculated Separately for Each Cruise and Replicate.....	G-1

TABLE OF CONTENTS (Continued)

	<u>Page</u>
Appendix H. Benthic Community Parameters Calculated Separately for Each Cruise, Replicates Combined.....	H-1
Appendix I. Chemical Analyses of Sediments.....	I-1
Appendix J. Sediment Grain-Size Analyses: Raw Data.....	J-1
Appendix K. Sediment Grain-Size Analyses: Summary Statistics.....	K-1
Appendix L. Carbon, Hydrogen, and Nitrogen (CHN) Data.....	L-1
Appendix M. CTD Profiles.....	M-1

INTRODUCTION

With the onset of oil and gas exploratory activities on the U.S. continental slope and rise, a need was identified for information on the structure and composition of deep-sea biological communities and the processes affecting those communities. Similarly, potential environmental impacts of drilling in deeper waters were not known. The "Study of Biological Processes on the U.S. Mid-Atlantic Slope and Rise" was initiated by the U.S. Department of the Interior, Minerals Management Service, in March 1984. The two-year study was performed by Battelle Ocean Sciences with subcontractors Woods Hole Oceanographic Institution (WHOI) and Lamont-Doherty Geological Observatory (LDGO). The objectives of the program were as follows:

1. To characterize pre-drilling biological, geological, and chemical properties of benthic environments at stations in the vicinity of two deep-water exploratory drilling rigs.
2. To monitor potential changes in these properties with time, and determine whether the changes were caused by drilling-related activities or were the result of other phenomena including natural temporal or spatial variation.
3. To determine the distribution and fate of discharged drilling-related materials that may have accumulated above background levels.
4. To estimate recovery rates of deep-sea benthic communities potentially impacted by activities related to drilling.

The parameters measured as part of this study were infaunal benthic community structure, including determination of ash-free dry weight of infauna at selected stations; rates of colonization of azoic sediments; megafaunal (epifaunal) population densities; hydrocarbon levels in sediments; hydrocarbon and trace metal levels in faunal tissues; chemical analysis of discharged drilling mud; sediment grain-size composition; and levels of total organic carbon, hydrogen, and nitrogen (CHN) in sediments. In addition, the U.S. Geological Survey (USGS) analyzed trace metals in sediments (Bothner et al., 1987).

FIELD PROGRAM

Six cruises over a two-year period were conducted to address the program objectives (Table 1). An array of 12 benthic sampling stations was planned to be centered around a deep-water drilling site. It was estimated that, at a water depth of about 2000 m, barite-sized particles could be distributed as far as 80 km downcurrent from the point of discharge and "smeared" in a cross-isobath direction for a distance of up to 4 km (Butman, unpublished calculations).

The drilling site chosen for monitoring was Shell Offshore, Inc.'s site in Block 372. Pre-drilling samples were collected in both Blocks 93 and 372 on three legs of a cruise between March and May 1984. Shell spudded a well in Block 372 on May 26, 1984. However, this site was plugged and abandoned on July 9, 1984. A new well was spudded in Block 93 on July 12, 1984. Two additional stations in Block 93 were therefore added to the station array in order to monitor the second drilling site. The majority of stations were located along the 2100-m isobath; the actual reference depths ranged from 2020 to 2209 m. Station 1 was established as close as possible to the actual drilling site in Block 372, and stations were then positioned at distances of 2, 22.5, 45, and 90 km on either side of that station. Stations 7 and 8 were approximately 22.5 km downcurrent of the drill site in a topographic high/low relationship; that is, the two stations were positioned as close together as possible, but with a difference of 50 m water depth between them. Stations 11 and 12, located at reference depths of 1515 and 2505 m, respectively, provided a cross-isobath transect in relation to Station 1. Station 14 was located near the drill site in Block 93 and Station 13 was approximately 2 km southwest of Station 14. The final station design is shown in Figure 1, and reference coordinates for all stations are summarized in Table 2.

The types of samples collected on each cruise are summarized in Table 3. The program for analysis of hydrocarbons in sediments was designed to sample all stations on the first two sampling cruises, but only five stations on the last four cruises. Collections of the brittle star Ophiomusium lymani and the urchin Echinus affinis for chemical analysis of tissues, and exposure of film footage for characterization of epifauna, were made on the first, second, and fifth cruises in the series. Samples of drilling muds were provided by Shell Offshore, Inc.

TABLE 1. SAMPLING SCHEDULE FOR U.S. MID-ATLANTIC MONITORING PROGRAM.

Cruise	Date	Vessel
Mid-1		
Leg 1	Mar/Apr 1984	R/V <u>Cape Hatteras</u>
Leg 2	May 1984	R/V <u>Oceanus</u>
Leg 3	May 1984	R/V <u>Gyre</u>
Mid-2	Aug 1984	R/V <u>Gyre</u>
Mid-3	Nov/Dec 1984	R/V <u>Oceanus</u>
Mid-4	May 1985	R/V <u>Oceanus</u>
Mid-5	Aug 1985	R/V <u>Oceanus</u>
Mid-6	Nov 1985	R/V <u>Gyre</u>

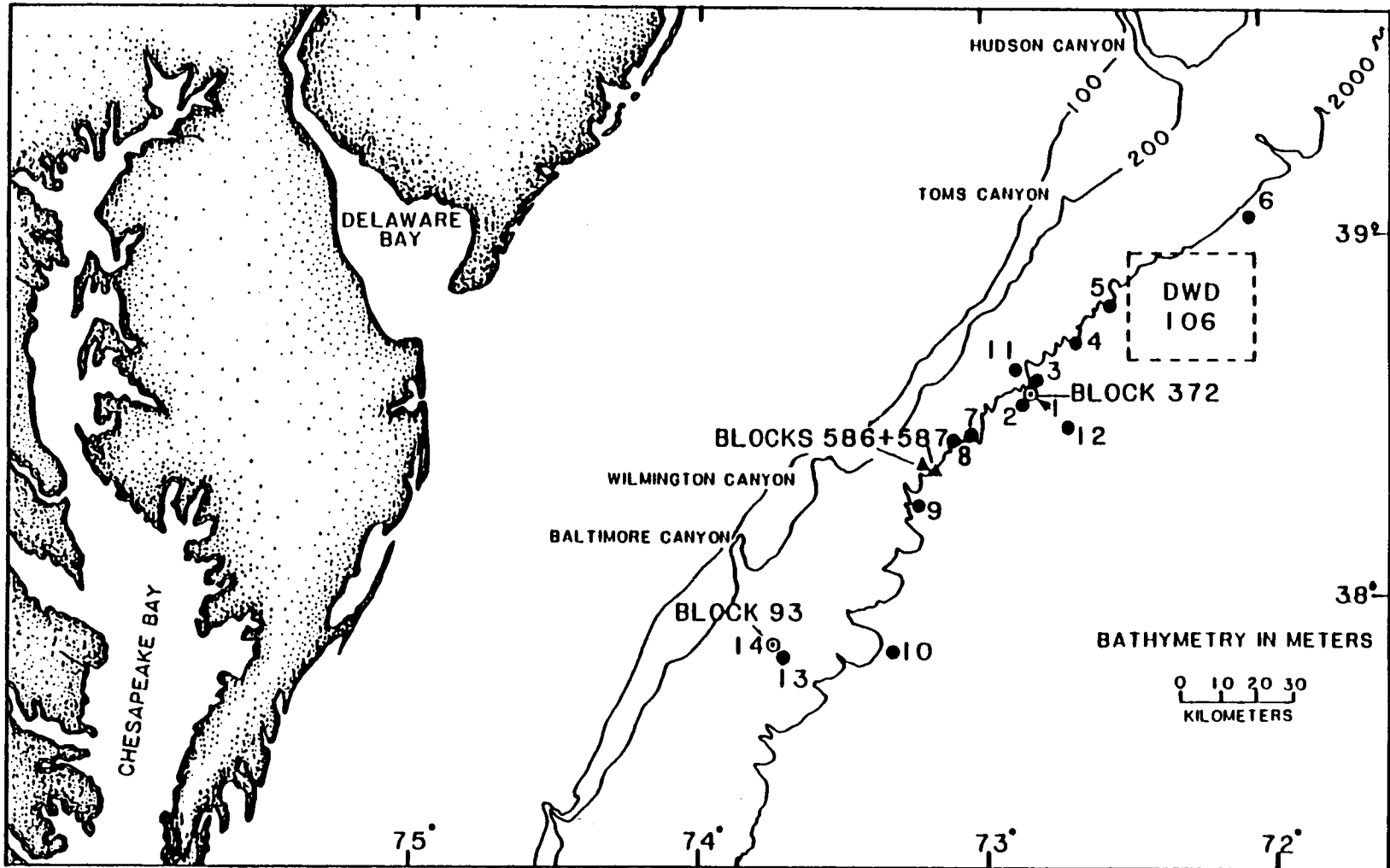

Figure 1. Station Locations on the Continental Slope and Rise for the U.S. Mid-Atlantic Monitoring Program.

TABLE 2. STATION REFERENCE COORDINATES FOR THE U.S. MID-ATLANTIC SLOPE AND RISE STUDY. LATITUDES AND LONGITUDES ARE BASED ON NORTHSTAR 6000.

Station	Latitude/ Longitude	Loran Time Delays	Reference Depth (m)	Actual Depths Sampled (m)
1	38°35.98'N 72°52.97'W	26365.6 42588.7	2195	2165-2209
2	38°35.78'N 72°53.65'W	26369.5 42586.2	2020	2005-2024
3	38°36.84'N 72°51.35'W	26357.0 42598.0	2055	2045-2064
4	38°44.47'N 72°33.01'W	26297.1 42675.1	2100	2091-2124
5	38°50.49'N 72°33.01'W	26249.4 42734.3	2065	2055-2090
6	39°05.54'N 72°02.97'W	26063.1 42878.2	2090	2045-2091
7	38°27.36'N 73°03.44'W	26423.0 42499.2	2100	2085-2110
8	38°27.31'N 73°04.87'W	26431.0 42497.8	2150	2148-2159
9	38°17.28'N 73°14.51'W	26480.6 42392.3	2105	2100-2114
10	37°51.80'N 73°19.84'W	26496.2 42137.0	2095	2093-2114
11	38°40.17'N 72°56.37'W	26386.8 42627.1	1515	1502-1540
12	38°29.30'N 72°42.15'W	26301.9 42532.0	2505	2495-2509
13	37°53.33'N 73°45.09'W	26628.4 42121.0	1613	1605-1619
14	37°53.91'N 73°44.62'W	26626.3 42126.8	1500	1409-1515

TABLE 3. SUMMARY OF SAMPLES COLLECTED AND ANALYZED FOR THE U.S. MID-ATLANTIC MONITORING PROGRAM.

Sample Type	Number of Stations or Transects	Number of Replicates Per Station	Number of Cruises	Total Collected	Total Analyzed
Infaunal Box Cores ^{a,b}	13-14 ^a	3	6	237	233
Meiofauna ^c	13-14	6	6	474	0
Sediment Grain Size	13-14	3	6	237	237
Sediment CHN	13-14	3	6	237	237
Sediment Hydrocarbons ^d	5-14	3	6	237	144 UV/F 40 GC/GCMS
Sediment Trace Metals ^e	13-14	6	6	474	e
Tissue Hydrocarbons ^f	3	1	3	9	9
Tissue Trace Metals ^f	3	1	3	9	9
Camera Sled Transects ^f	2.5	1	3	7.5	7.5
Colonization Trays	2	3	3	12	11
Biomass Box Cores	2	3	1	6	6
Hydrography ^g					
Dissolved Oxygen	13-14	3	6	237	225
Salinity	13-14	3	6	237	225
Temperature	13-14	3	6	237	225

^aFourteen stations were sampled on the first cruise, 13 stations were sampled on Cruises 2-6.

^bFour replicates were not processed, see Chapter 3.

^cMeiofauna samples are archived at Battelle.

^dSee Chapter 7, Volume 2, for chemistry analytical program.

^eSediment trace metal samples were analyzed at USGS, Woods Hole. See Bothner et al. (1987).

^fTissue samples and camera transects were taken on Cruises 1, 2, and 5.

^gSome hydrographic data were not collected on certain cruises, or were unusable.

Box Core Sampling

At all stations, a Mark III 0.25-m² box corer was used to collect three replicate samples. The core box was partitioned into 25 subcores, each with a surface area of 0.01 m². All subcores for trace metals were precoated with Teflon. A block of nine contiguous subcores was designated for infaunal analysis, with additional subcores designated for CHN, sediment grain size, trace metal chemistry, hydrocarbon chemistry, and meiofauna samples. Samples for biological analysis were sieved on 0.3-mm mesh screens, preserved in 10 percent buffered formalin, and later transferred to 80 percent alcohol. Meiofaunal samples were preserved without sieving in 5 percent buffered formalin and archived at Battelle. Samples for chemical, sediment grain-size, and CHN determinations were frozen until analysis. A total of 237 box cores were collected on the six cruises; all box cores were positioned in a tight array at each station.

Six additional box cores were collected specifically to obtain samples for the determination of ash-free dry weight (AFDW) of the fauna. Three samples were collected at each of two stations (Stations 6 and 10) in August 1985. Nine contiguous subcores were removed from each box core and preserved in formalin.

Camera Transects

The LDGO-developed camera sled BERNEI (Benthic Equipment for Reptant and Natant Epifaunal Imaging) was used to photograph epifauna in the vicinity of the Block 372 drilling site. Two transects were surveyed prior to drilling, and again 2 months and 14 months after drilling was completed (Figure 2). One transect was 44 km long and passed through the drill site, starting 35 km downcurrent (SW) and ending 9 km upcurrent (NE). A second transect circumscribed a circle with a radius of 2.3 km around the drill site. This 17.3-km-long transect surveyed areas both upslope and downslope from the drill site, as well as in downcurrent and upcurrent directions. The camera sled was towed at an average speed of 1 kn, and exposures were made at 15-s intervals. Each exposure covered an area of 5 m².

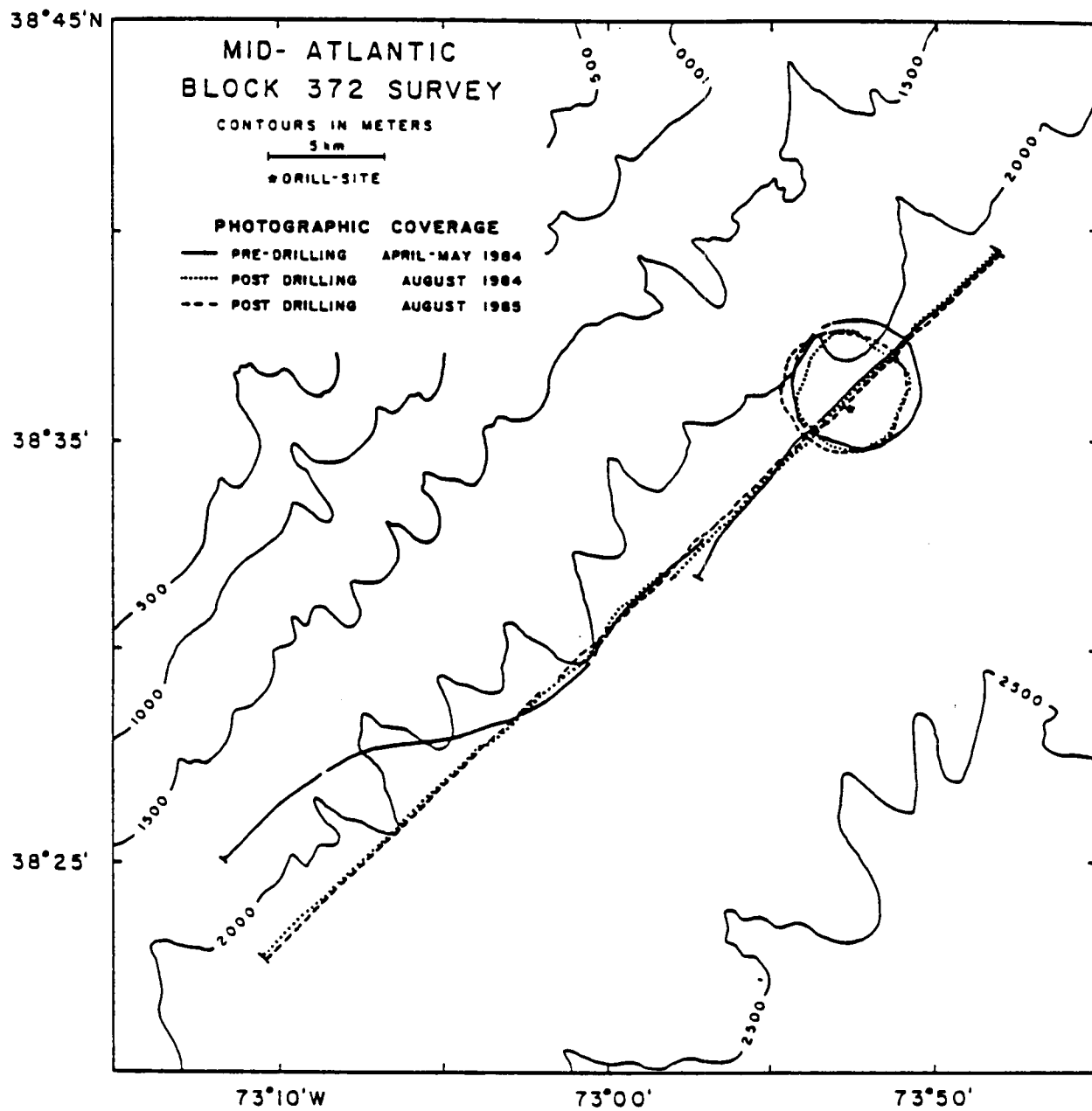

Figure 2. Photographic Coverage from Nine Camera-Sled Tows in the Vicinity of the Block 372 Drill Site.

Recolonization Trays

Twelve arrays of sediment trays were deployed over the course of the experiment. Trays were deployed for 6- and 12-month time periods at Station 2 (near the drill site) and Station 4 (upcurrent of the drill site). A second set of 6-month trays was deployed at Station 2.

Mud to be used in the recolonization experiments was collected from all of the U.S. Mid-Atlantic stations. This mud consisted of the 0- to 10-cm fraction of the undesignated subcores from each box core. The sediment was stored in 20-gal polyethylene containers and frozen until use, at which time it was thawed and homogenized. Each of three trays was filled to the brim with sediment; the other three trays in each array were either left empty to see how much sediment was trapped or filled with sediment for additional analyses, if needed.

Bottom Trawls

A 40-ft Gulf of Mexico trawl was used on three cruises (Mid-1, Mid-2, and Mid-5) to collect the brittle star Ophiomusium lymani and the urchin Echinus affinis for tissue analysis of trace metals and hydrocarbons. Voucher specimens were also collected for correlation with the bottom photographs. Specimens for chemical analysis were placed in pre-labeled Teflon jars and frozen until analysis. Specimens to be retained as biological vouchers were preserved in 10 percent buffered formalin and later transferred to 80 percent alcohol.

Hydrographic Measurements

At each station, hydrocasts were made using a Niskin bottle equipped with three reversing thermometers. Samples of near-bottom water were collected for measurements of temperature, salinity, and dissolved oxygen. Triplicate salinity samples were drawn and stored for transfer to WHOI where salinity was measured using an Autosal conductivity probe. Dissolved oxygen was determined by the Winkler titration method. Samples were analyzed in triplicate aboard ship. On the second cruise, a CTD unit integrated with the shipboard Hewlett Packard computer system was used to provide a continuous profile of temperature and salinity with depth.

BIOLOGICAL PROCESSES

Benthic Infaunal Community Structure

In the laboratory, each infaunal sample was transferred to 80 percent alcohol, stained with Rose Bengal, and sorted under a dissecting microscope. Organisms were identified to the lowest practicable taxon, usually to the species level. Certain taxonomic groups, i.e., amphipods, isopods, tanaidaceans, bivalves, and scaphopods, were identified by taxonomists on the WHOI staff. All other taxonomic groups, including polychaetes, oligochaetes, echinoderms, decapod crustaceans, gastropods, aplacophorans, pogonophorans, and sipunculans, were identified by Battelle staff. Dr. Leslie G. Watling, University of Maine, identified all cumaceans.

Species identifications were confirmed by several consultants, including Dr. John Allen, Dove Marine Laboratory, Scotland, thyasirid bivalves; Dr. Edward Cutler, Union College, sipunculans; Dr. Michael Rex, University of Massachusetts, gastropods; Ms. Amalie Scheltema, WHOI, aplacophorans; Dr. Kenneth Sebens, Northeastern University, anthozoans; Dr. Leslie G. Watling, University of Maine, amphipods; and Dr. George D.F. Wilson, Scripps Institution of Oceanography, isopods.

Statistical analysis included calculation of the Shannon-Weiner diversity index, Hurlbert rarefaction curves (Hurlbert, 1971), and species accumulation curves (Gaufin et al., 1956). An agglomerative clustering technique was used to determine similarity among samples. The similarity measures used were the Normalized Expected Species Shared (NESS) (Grassle and Smith, 1976), and the Bray-Curtis index (Boesch, 1977), which was calculated on both untransformed and log-transformed data. Species abundances were ordinated by reciprocal averaging (Hill, 1973, 1974). Mean densities of the top 18 dominant species were examined for each station and cruise. For each species, differences among stations for each sampling date and differences among sampling times at each station were tested by means of a one-way Analysis of Variance (ANOVA). For ANOVAs indicating significant differences, the differences among means were examined using the Student-Newman-Keuls least-significant range procedure (Sokal and Rohlf, 1969).

A total of 862 species representing 16 phyla was identified from the box core samples (Table 4). Of these, 489 species (56.7 percent) are undescribed. The largest percentage of new species recorded in major phyla were arthropods: 139 species (68 percent) are new to science. Sixty-four percent (236 species) of the polychaetes are undescribed. Within several polychaete families that have a high number of species, such as the Dorvilleidae, Cirratulidae, Spionidae, Flabelligeridae, and Terebellidae, the percentage of new species ranged from 75 to 93 percent. Five new species of oligochaetes were also found out of the 18 species recorded. Forty-two species, or 36.5 percent, of the molluscs are new to science. Additional undescribed species were found in the phyla Porifera (4), Cnidaria (22), Nemertea (23), Echiurida (4), Bryozoa (3), Brachiopoda (2), Echinodermata (5), and Hemichordata (4). In many cases, these new species represent 100 percent of the species recorded in the particular phylum.

In the companion programs to this study, Blake et al. (1987) reported 1202 species identified from 76 box cores taken on the U.S. South Atlantic slope and rise, and Maciolek et al. (1987) reported 1019 species identified from 191 samples taken on the U.S. North Atlantic slope and rise. In both studies, the percentage of new or undescribed taxa was similar to that reported for the Mid-Atlantic study area. The recognition that approximately half of the species collected are undescribed is important when comparing results of diversity and species composition with results of any other study of deep-sea benthos. The correct identification of the taxa composing the benthic communities is made substantially more difficult when the species are not documented in the published literature. A lower level of recognition of separate taxa would result in lower estimates of diversity.

The phylogenetic composition of infaunal communities in the Mid-Atlantic study area is generally similar to that reported for other continental slope and rise depths (Blake et al., 1987; Maciolek et al., 1987) and also to the majority of continental shelf communities (Maciolek-Blake et al., 1985). Annelids accounted for nearly 45 percent of all species recorded and were represented in the present study by 367 species of polychaetes in 46 families and 18 species of oligochaetes. The Spionidae, Ampharetidae, Paraonidae, Cirratulidae, and Dorvilleidae were the best represented polychaete families, with 33, 27, 24, 24, and 23 species, respectively. These same families were also important in the benthic communities on both the U.S. South and North Atlantic slope, although the family Phyllodocidae, with 26 species, was also dominant in the South Atlantic samples.

TABLE 4. TAXONOMIC COMPOSITION OF SPECIES IDENTIFIED FROM U.S. MID-ATLANTIC INFAUNAL SAMPLES.

Taxon	Number of Species	Percent of Total Species	Taxon	Number of Species	Percent of Total Species
Porifera	5	0.6	Scalibregmatidae	4	
Cnidaria	42	4.9	Sigalionidae	4	
Hydrozoa	25		Sphaerodoridae	8	
Anthozoa	14		Spionidae	33	
Scyphozoa	3		Syllidae	8	
Platyhelminthes	1	0.1	Terebellidae	14	
Nemertinea	23	2.7	Trichobranchidae	8	
Priapulida	2	0.2	Trochochaetidae	1	
Annelida		44.7	Uncispionidae	1	
Polychaeta	367	42.6	Unassigned	3	
Acrocirridae	2		Oligochaeta	18	2.1
Ampharetidae	28		Echiurida	4	0.5
Amphinomidae	1		Sipuncula	15	1.7
Aphroditidae	2		Pogonophora	13	1.5
Apostobranchidae	1		Mollusca	115	13.3
Arabellidae	1		Bivalvia	45	
Capitellidae	20		Gastropoda	36	
Chaetopteridae	1		Scaphopoda	9	
Chrysopetalidae	5		Aplacophora	25	
Cirratulidae	26		Arthropoda	202	23.4
Cossuridae	2		Mysidacea	4	
Dorvilleidae	24		Decapoda	3	
Fauveliopsidae	3		Cumacea	26	
Flabelligeridae	7		Tanaidacea	45	
Glyceridae	2		Isopoda	59	
Goniadidae	3		Amphipoda	64	
Hesionidae	6		Pycnogonida	1	
Heterospionidae	1		Bryozoa	4	0.5
Lacydoniidae	1		Brachiopoda	2	0.2
Lumbrineridae	10		Echinodermata	39	4.5
Maldanidae	21		Echinoidea	9	
Nephtyidae	3		Ophiuroidea	16	
Nereididae	4		Asteroidea	3	
Onuphidae	10		Holothuroidea	11	
Opheidae	6		Hemichordata	4	0.5
Orbiniidae	7		Chordata		
Oweniidae	16		Ascidacea	5	0.6
Paralacydoniidae	1				
Paraonidae	24		TOTAL:	862	100.0
Phobididae	1				
Phyllodocidae	18				
Pilargidae	4				
Poecilochaetidae	1				
Polynoidae	3				
Protodrilidae	1				
Sabelliidae	1				
Sabellidae	16				

The phylum Arthropoda was an important component of the fauna, and accounted for 23.4 percent of all species recorded. The orders Isopoda, Amphipoda, Tanaidacea, and Cumacea were the dominant arthropod groups. Approximately 13.3 percent of the species were molluscs, including bivalves, gastropods, aplousobranchs, and scaphopods. The remaining phyla were relatively less common, and included groups, such as sipunculans and pogonophorans, that are typical of deep-sea (rather than coastal or shelf) fauna.

The majority of dominant species at any depth interval were polychaetes, which comprised a total of 11 to 13 of the top 20 species (Table 5). The spionid polychaete Aurospio dibranchiata was the top dominant at the 11 stations deeper than 2020 m. This species was also dominant in the U.S. North Atlantic samples from similar depths, but was replaced by another small polychaete, Microrbinia linea, south of Cape Lookout (Maciolek et al., 1987; Blake et al., 1987). At the shallower (1500-1600 m) stations, the communities were dominated by the sipunculan Aspidosiphon zinni and the aplousobranch mollusc Prochaetoderma yongei. These same species also dominated mid-slope communities in the U.S. North Atlantic study area (Maciolek et al., 1987), and were found in the U.S. South Atlantic study area as far south as Cape Lookout (Blake et al., 1987). The dominance of these large burrowing forms in mid-slope depths may be related to marginally slower water currents, which may result in a greater deposition of organic material to support these organisms than is seen in areas with faster currents.

The actual percent contribution of individual species to each station varied very little among stations. For example, abundances of the most common species, A. dibranchiata, ranged from 6-8 percent of the total individuals at all ten 2100-m stations, and the successively less common species had abundances of 2-7 percent, 3-5 percent, 2-5 percent, 2-3 percent, 1-4 percent, 2-4 percent, and 2-3 percent, respectively. The ninth and tenth most common species accounted for an average of 2 percent of individuals at every station. In disturbed deep-sea environments, the most abundant species may represent more than half the individuals. For example, Thistle et al. (1985) found that the polychaete Paedampharete acutiseris made up 50-64 percent of the fauna in an area where the currents may be 20-25 cm/s for periods of several days. Smith et al. (1986) reported abundances of 67 percent of the polychaete Levinsenia oculata in background samples in an area characterized by dense concentrations of megafaunal mounds. Artificial mounds also produced similar proportions of the same species after 50 days. Grassle and Morse-Porteous (in press) found that the polychaete Ophryotrocha sp. A

TABLE 5. DOMINANT SPECIES RECORDED AT U.S. MID-ATLANTIC STATIONS, PRESENTED FOR STATIONS SUMMED ACCORDING TO DEPTH INTERVALS.

Stations 11, 13 and 14 (1515-1613 m)	Stations 1-10 (2020-2195 m)	Station 12 (2500 m)
1. <u>Aspidosiphon zinni</u> (S)	1. <u>Aurospio dibranchiata</u> (P)	1. <u>Aurospio dibranchiata</u> (P)
2. <u>Prochaetoderma yongei</u> (A)	2. <u>Pholoe anoculata</u> (P)	2. <u>Tharyx</u> sp. 1 (P)
3. <u>Aurospio dibranchiata</u> (P)	3. <u>Spathoderma clenchi</u> (A)	3. <u>Prionospio</u> sp. 2 (P)
4. <u>Aricidea tetrabranchia</u> (P)	4. <u>Tharyx</u> sp. 1 (P)	4. <u>Myriochele</u> sp. 1 (P)
5. <u>Glycera capitata</u> (P)	5. <u>Prionospio</u> sp. 2 (P)	5. <u>Paradoneis abranchiata</u> (P)
6. <u>Pholoe anoculata</u> (P)	6. <u>Tubificoides aculeatus</u> (O)	6. <u>Phalldrillus grasslei</u> (O)
7. <u>Kesun gravieri</u> (P)	7. <u>Prochaetoderma yongei</u> (A)	7. <u>Glycera capitata</u> (P)
8. <u>Tharyx</u> sp. 1 (P)	8. <u>Aricidea tetrabranchia</u> (P)	8. <u>Pholoe anoculata</u> (P)
9. <u>Lumbrineris latreilli</u> (P)	9. <u>Glycera capitata</u> (P)	9. Nemertea sp. 5 (N)
10. <u>Leptognathiella spinicauda</u> (T)	10. Nemertea sp. 5 (N)	10. <u>Aspidosiphon zinni</u> (S)
11. <u>Prionospio</u> sp. 11 (P)	11. <u>Sabidius cornatus</u> (P)	11. <u>Spathoderma clenchi</u> (A)
12. <u>Tubificoides aculeatus</u> (O)	12. <u>Fauveliopsis brevis</u> (P)	12. <u>Fauveliopsis brevis</u> (P)
13. Nemertea sp. 5 (N)	13. <u>Aricidea abranchiata</u> (P)	13. <u>Tubificoides aculeatus</u> (O)
14. <u>Prionospio</u> sp. 2 (P)	14. <u>Kesun gravieri</u> (P)	14. <u>Chaetozone</u> sp. 1 (P)
15. <u>Paranarthrura cf. insignis</u> (T)	15. <u>Grania atlantica</u> (O)	15. <u>Dacrydium</u> sp. 1 (B)
16. <u>Nucula granulosa</u> (B)	16. <u>Notomastus latericeus</u> (P)	16. Sabellidae sp. 5 (P)
17. <u>Dysponetus</u> sp. 4 (P)	17. <u>Levinsenia</u> sp. 1 (P)	17. <u>Notomastus latericeus</u> (P)
18. <u>Chaetozone</u> sp. 1 (P)	18. <u>Haplomesus</u> sp. 2 (I)	18. <u>Aricidea tetrabranchia</u> (P)
19. Nemertea sp. 2 (N)	19. <u>Prionospio</u> sp. 11 (P)	19. <u>Euchone</u> sp. 3 (P)
20. <u>Euchone</u> sp. 3 (P)	20. <u>Oecidiobanchus plebejum</u> (I)	20. <u>Nucula cancellata</u> (B)

A = Aplacophora; B = Bivalvia; I = Isopoda; N = Nemertea; O = Oligochaeta; P = Polychaeta; S = Sipuncula; T = Tanaidacea

comprised 38 percent of the individuals in cores dominated by decomposing Sargassum weed from 3600 m depth off New England. Another member of the same genus, O. akessoni, accounted for more than 90 percent of the individuals in sediments affected by hydrothermal venting (Grassle et al., 1985).

Species diversity was evaluated by several methods, including Hurlbert rarefaction, species accumulation over increasing area, and Shannon-Wiener diversity. Figures 3 and 4 show rarefaction diversity curves for the total fauna and three major faunal groups considered separately at each station. The shallower (1515 to 1613 m) Stations 11-14 were more diverse than the deeper stations. Station 10 is the most diverse of the 2100-m stations and Station 4 is the least diverse. This is, in part, because the samples from Station 10 contain a number of rare species that are presumed to be more common to the south of this station.

Polychaetes were always the most diverse taxon, followed by peracarid crustacea and molluscs. The peracarid diversity curve at a depth of 2500 m (Station 12) is particularly steep and close to the diversity of polychaetes at the 2100-m stations (Figure 4).

Shannon-Wiener diversity at individual stations ranged from means of 5.35 at the 2500-m Station 12 to 6.00 at the 2100-m Station 7. This method of calculating diversity gives results close to the Hurlbert rarefaction value for the expected number of species at 10 individuals (Smith et al., 1979). The higher diversity of the 1500-m stations was not evident in this measure, but was clear in the species accumulation plots for each station.

The expected number of species per 1000 individuals at the mid-slope Mid-Atlantic stations ranged from 176 to 184; whereas at the remaining Mid-Atlantic stations the same parameter ranged from 144 to 171 species per 1000 individuals. Similar results were obtained in the U.S. North Atlantic study area (Maciolek et al., 1987) where the mid-slope stations at 1220 to 1350 m exhibited higher diversities than either shallower (250 to 550 m) or deeper (2100 m) stations. Exceptions to this pattern were seen in the U.S. South Atlantic, where stations at 600, 2000, and 3000 m exhibited very high diversities (Blake et al., 1987). However, the highest diversity recorded in the entire U.S. Atlantic slope and rise program was at an 800-m station off Charleston, S.C., where the expected number of species per 1000 individuals was 223 (Blake et al., 1987). These results do not agree with

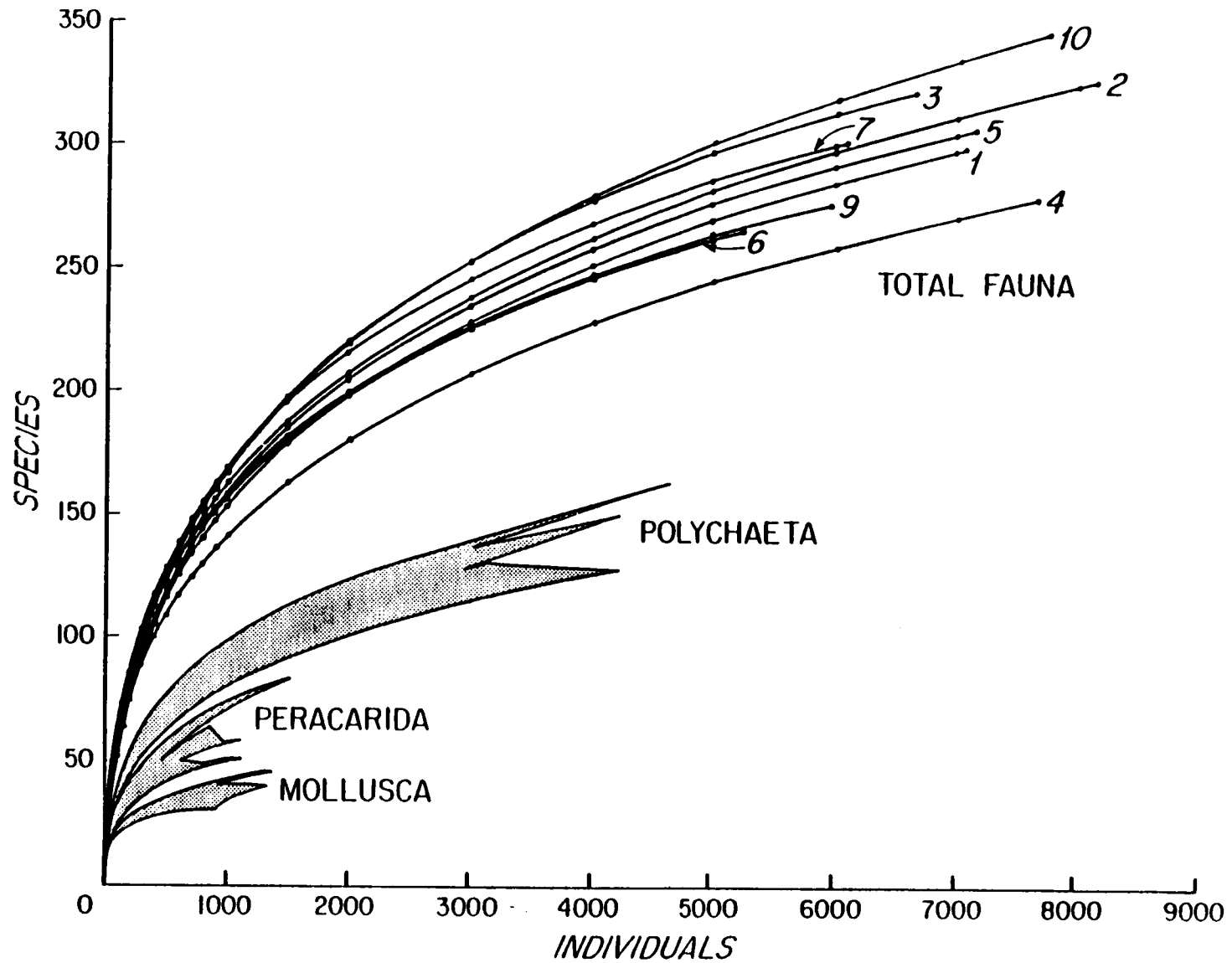

Figure 3. Rarefaction Curves for Total Fauna, Polychaeta, Peracarida, and Mollusca at U.S. Mid-Atlantic Stations 1-7, 9, and 10. The Jagged Right Edges of the Lower Curves Indicate the Actual Endpoints of the Nine Stations Included in Each of the Three Shaded Areas.

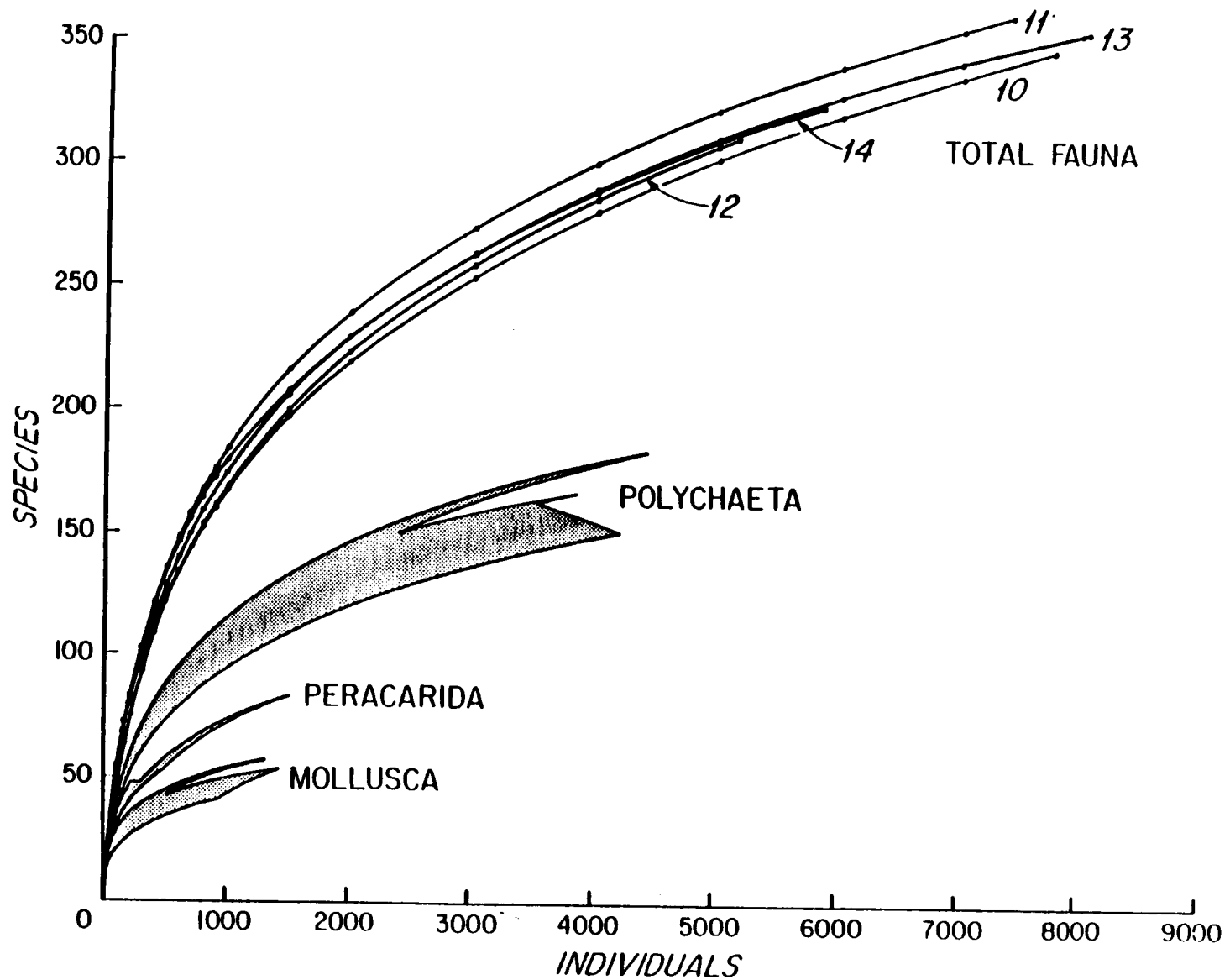

Figure 4. Rarefaction Curves for Total Fauna, Polychaeta, Peracarida, and Mollusca at U.S. Mid-Atlantic Stations 10 through 14. The Jagged Right Edges of the Lower Curves Indicate the Actual Endpoints of the Five Stations Included in Each of the Three Shaded Areas.

the conclusions reached by Rex (1983), who reviewed patterns of diversity for several major faunal groups. In Rex's review, he reported that diversities increased with depth to a maximum at about 2000 to 3000 m. However, most of the data that Rex used were based on qualitative epibenthic sled samples; whereas the present results are based on detailed quantitative data.

The major clusters delineated by classification and ordination correspond to the three major depth intervals sampled: 1500, 2100, and 2500 m (Figure 5). Within each of these depth intervals, samples from each station were generally more similar to each other than to samples from any other station. Samples from most stations clustered with other samples from the same station before joining with the next station. Station 12, at 2500 m the deepest station sampled, forms a distinct unit to the right of the diagram. The 1515- to 1613-m stations, Stations 11, 13, and 14, form a second large cluster. Stations 13 and 14 cluster with each other before joining with Station 11. This difference may be related to geographic position, because Station 11 is approximately 90 km to the northeast of Stations 13 and 14, which were only approximately 2 km distant from each other. The November 1985 (Cruise Mid-6) value for Station 11 was highly dissimilar not only to the other sampling times for Station 11, but also to the rest of the cluster composed of the three shallower stations. This result can be explained by the fact that of the two replicates analyzed for this sampling data at Station 11, one replicate had a highly unusual faunal composition. Several species present in high numbers in that one replicate were either rare or were not found at all in any other sample analyzed during this study.

The third major cluster shown in Figure 5 is composed of the 2100-m stations. Samples from Station 10 form a distinct station cluster, but this group joins with a cluster composed of samples from Stations 2 and 3 before joining with samples from the remaining 2100-m stations. Station 6 is the only other station for which all samples cluster together before joining with samples from remaining stations. Samples from Stations 7, 8, and 9 form a large cluster that, with the exception of Station 9, Cruise Mid-6, joins with Station 6 at the 0.90 level. Samples from Stations 4 and 5 cluster together before joining with samples from Station 1.

The results of the present study indicate that the species composition and abundance of benthic infauna is remarkably homogeneous at depths of 2020 to 2195 m along the 176-

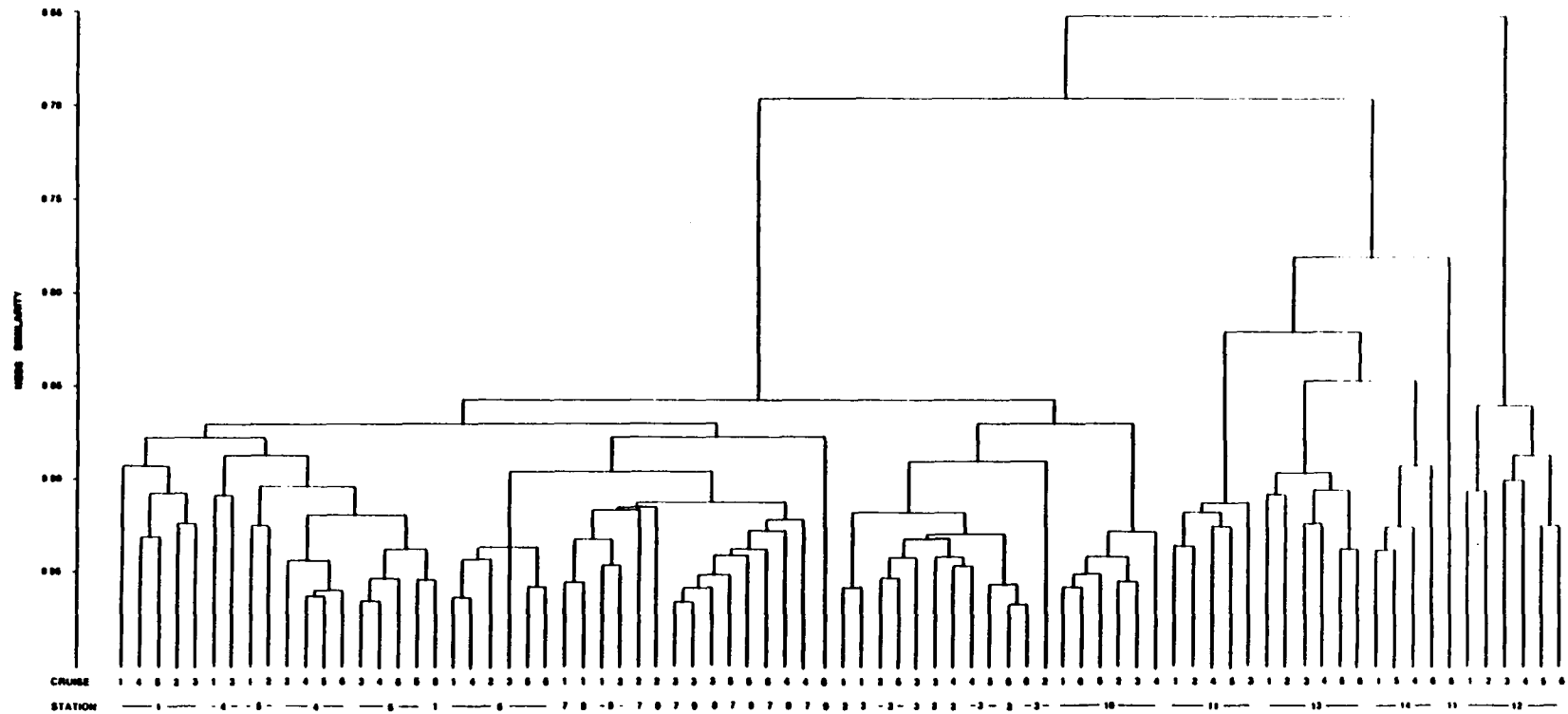

Figure 5. Summed Replicates Collected at Each Station Between April 1984 and November 1985 (Cruises Mid-1 Through Mid-6) Clustered by NESS at 200 Individuals and Group Average Sorting.

km-long transect sampled. This high similarity along depth contours was also seen in the U.S. North Atlantic study area (Maciolek et al., 1987) but is in sharp contrast to the remarkable heterogeneity reported by Blake et al. (1987) for the slope and rise south of Cape Hatteras. In the Mid-Atlantic study area, the mean NESS similarity ($m = 50$) of adjacent pairs of stations is $0.83 + .05$ (95 percent confidence limits) for the six northernmost stations (Stations 1-6), and $0.79 + .05$ between the most distant stations (Stations 6 and 10). The NESS similarities ($m = 200$) for all samples from the ten 2100-m stations were greater than 0.85 when a cluster analysis using a group average sorting was performed.

Because these similarities were so high, the entire fauna along the 2020- to 2195-m depth interval was considered to represent a single community and species accumulation and rarefaction curves were calculated based on 125 of the samples. This calculation indicated an extremely diverse fauna with many more species to be added with additional sampling (Figure 6). The curve did not reach an asymptote, but continues to climb, adding on the order of 30 species for every 10,000 individuals added. The five qualitative trawl samples for which all of the fauna has been analyzed (Hessler and Sanders, 1967) had 185-364 species for 4000 to 25,000 individuals. These samples fall well below the diversity curves for the present samples, in part because the epibenthic sled used by Hessler and Sanders captured only the surface fauna, and in part because there have been major developments in systematics of deep-sea invertebrates in the intervening 20 years. Shallow-water communities outside of tropical areas have relatively few species. The best-studied communities are from intertidal areas or coastal embayments where the number of species per number of individuals collected reaches an asymptote at less than 100 species (e.g., Hessler and Sanders, 1967). Communities on the continental shelf are more diverse than shallow-water communities, but 70 samples taken from a station at 80-m water depth on Georges Bank indicated that an asymptote was reached at about 200 species (Maciolek-Blake et al., 1985).

Biomass

Ash-free dry weight (AFDW) was determined for six box core samples collected specifically for these measurements. Each sample was resieved on 2.0-mm and 0.3-mm

2100 Meter Stations

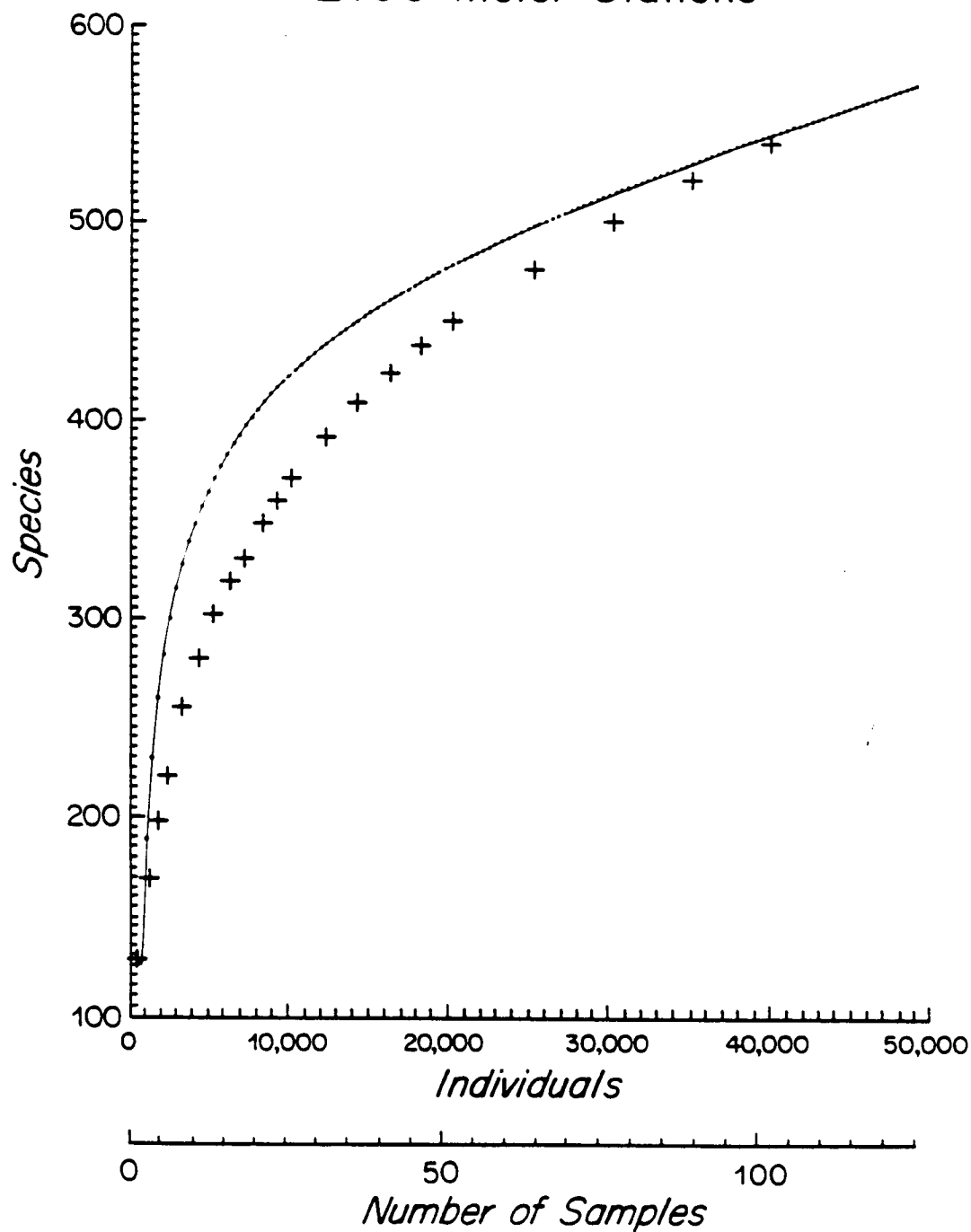

Figure 6. The Upper Curve is a Computer-Generated Species-Area Plot of the Mean Number of Species for Each Combination of Samples from the 2100-m Stations 1-5, 7, and 9 Regardless of Sampling Date. Plus (+) Symbols Mark the Species/Individuals Relationship Calculated by Rarefaction From a Single Summation of the 125 Separate Samples.

mesh sieves and the organisms were sorted into major taxonomic categories. Wet weights were first obtained for each category, with the two size fractions kept separate throughout. Dry weights were obtained after drying the samples at 600°C for 24 hr to remove water. Samples were then ashed in a muffle furnace at 450°C for 4 hr. After ashing, containers were placed in a dessicator for at least 12 hr, after which the sample was weighed. The AFDW was calculated as the difference between the dry weight and the ash weight.

Total wet weight, dry weight, and AFDW at Station 10 were approximately five, six, and two times higher, respectively, than the same parameters at Station 6 (Figure 7). There was a great deal of variability among replicates: at Station 6, for example, AFDW ranged between 0.133 and 0.188 g/m²; whereas the range at Station 10 was between 0.168 and 0.779 g/m². The higher values at Station 10 can be attributed to one of the three replicates, which had higher biomass values in several categories. Annelids and bivalves constituted 82.6 percent of the mean total AFDW at Station 6, accounting for 0.107 and 0.030 g/m², respectively (Figure 8). At Station 10, annelids and ophiuroids, with 0.124 and 0.066 g/m², respectively, accounted for 49.9 percent of the mean total AFDW (Figure 8).

At Station 6, the 0.3-mm and 2.0-mm size fractions contributed 57.1 and 42.9 percent, respectively, of the fauna. Values for the total wet weight, dry weight, and AFDW did not differ significantly between the two size fractions. At Station 10, the 0.3-mm and 2.0-mm size fractions contributed 39.0 and 61.0 percent of the total, respectively. The total AFDW of the 2.0-mm size fraction at Station 10 was 1.6 times that of the 0.3-mm fraction.

The data developed for the Mid-Atlantic stations are directly comparable with values generated for stations at similar depths in both the U.S. South and North Atlantic study areas (Blake et al., 1987; Maciolek et al., 1987). The Mid-Atlantic biomass values appear to be most similar to values from the two South Atlantic stations; whereas mean values from the two North Atlantic stations are an order of magnitude higher than mean values from the other four stations sampled. These measurements represent the first measurements of AFDW for continental slope environments. Other investigators have reported only wet weight or dry weight (e.g., Khripounoff et al., 1980; Rowe, 1983; Dinet et al., 1985). The wet weight and dry weight measurements developed for the present samples are generally comparable to, although higher than, those made by other

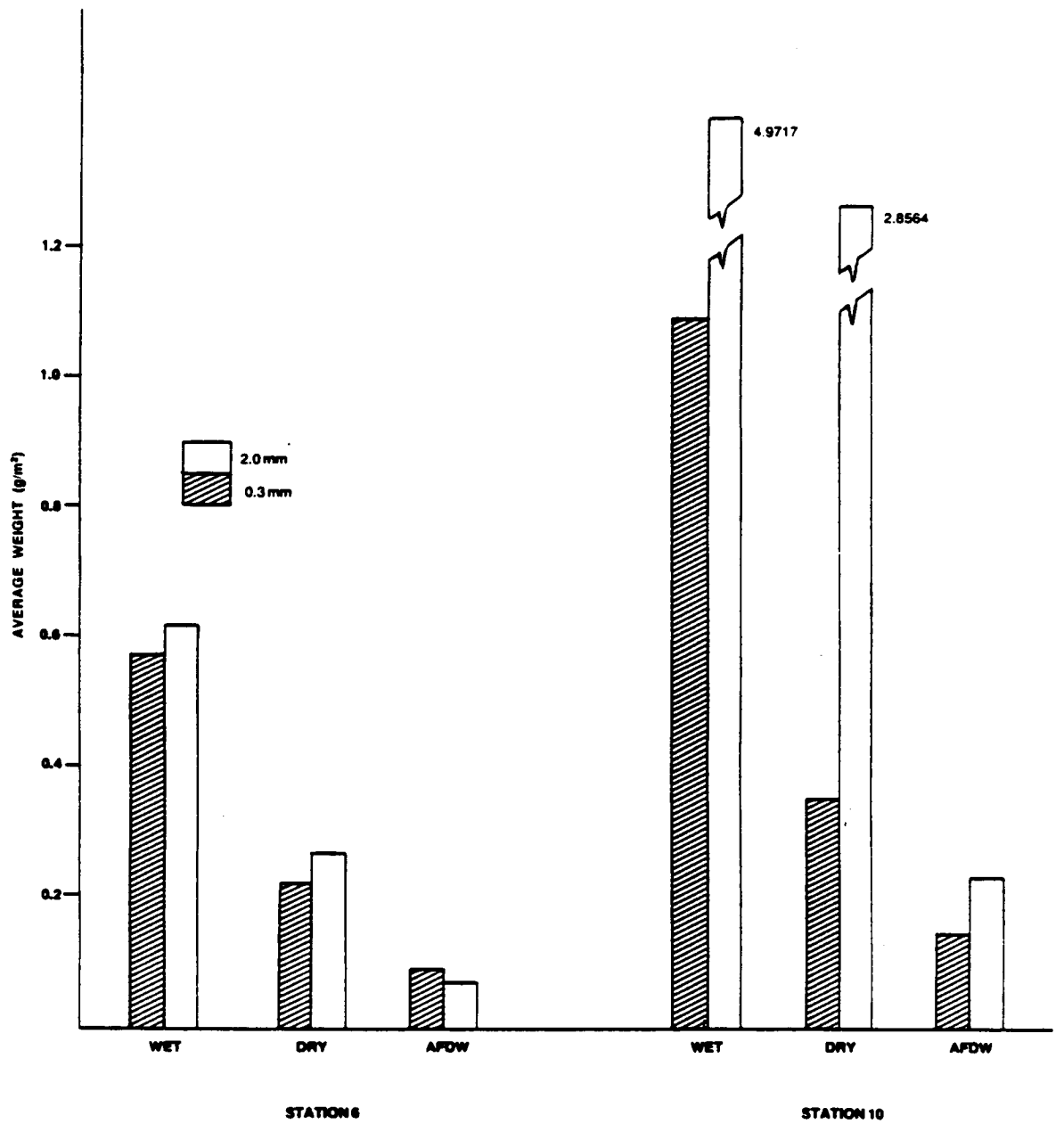

Figure 7. Average Wet, Dry, and Ash-Free Dry Weights (AFDW) (g/m²) For Each Size Fraction at Stations 6 and 10 From Cruise Mid-5.

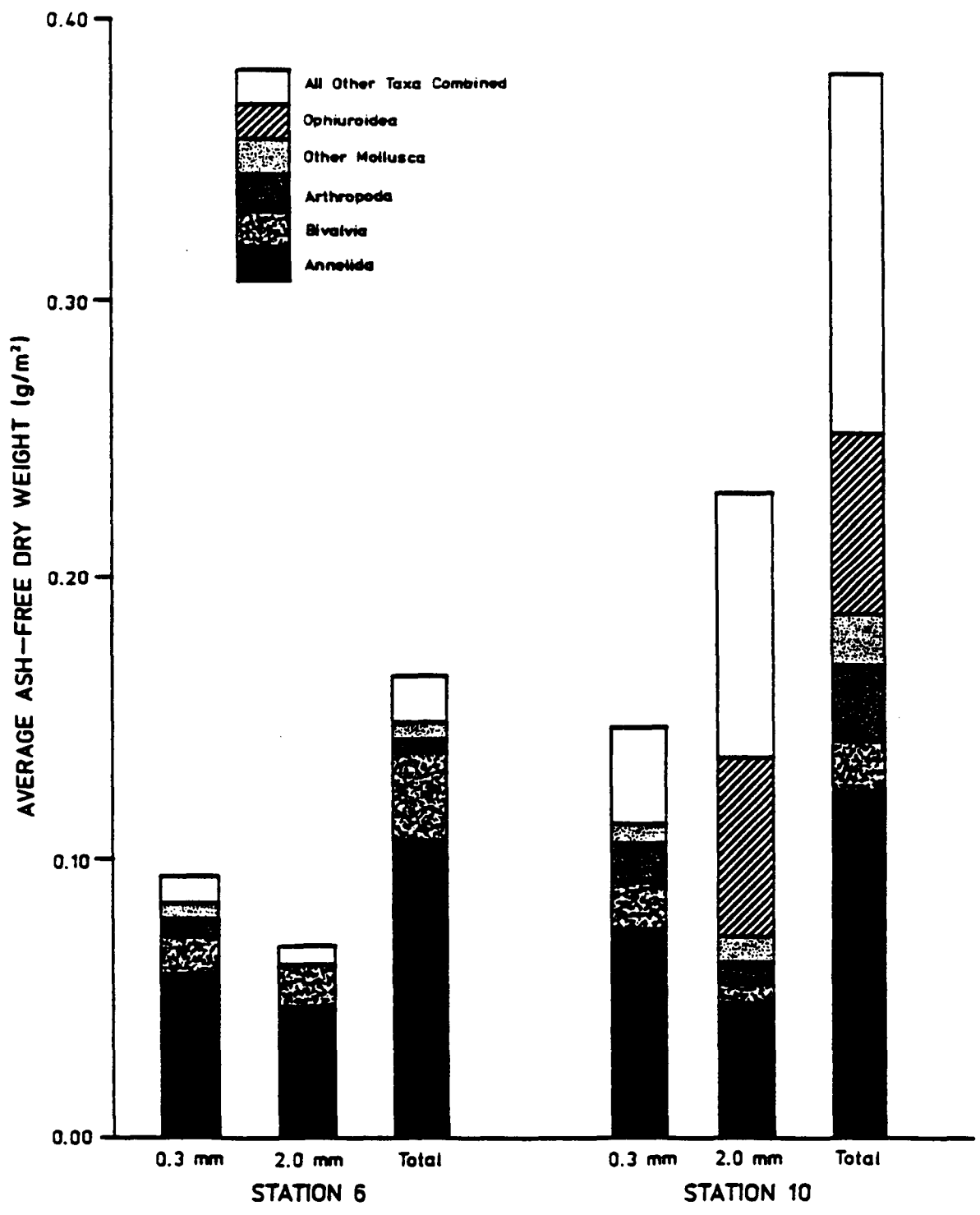

Figure 8. Average Ash-Free Dry Weight (AFDW) (mg/m^2) for Taxonomic Categories in Each Size Fraction at Stations 6 and 10. Size Fractions Presented Separately and Combined.

investigators, despite some differences in sample collection and processing methods. High variability of biomass among samples is not restricted to slope and rise environments, but has also been observed on continental shelf areas such as Georges Bank (Maurer and Wigley, 1984; Brown, 1985). This high variability results from the presence of a few large, heavy-bodied animals, usually molluscs or echinoderms, in one of the replicates.

Benthic Recolonization Experiments

Infaunal samples from the benthic recolonization trays were processed in the same manner as the subcores from the box cores for infaunal analyses, with the exception that the nine subcores from the trays were processed individually rather than combined. In most instances, samples were also saved for sediment grain-size and CHN analyses, and additional subcores were archived for trace metal and organic analyses.

The first set of six-month trays were deployed in April and retrieved in November 1984. The fauna in these trays was quite similar between replicates and stations. The total number of individuals in each tray ranged from 12 to 24 and the number of species ranged from 9 to 18. Auospio dibranchiata, the top dominant in the box core samples taken at the two stations, was the most common species in the trays at both stations. At Station 2, the deployment closest to the drilling rig, the numbers of A. dibranchiata and Capitella spp. declined after one year. At Station 4, the numbers of A. dibranchiata increased sharply; whereas Capitella spp. remained the same. Several other species also differed in density between the two stations. The total number of individuals in the one-year trays at Station 4 was also significantly greater than at Station 2. However, the differences in the one-year trays can be attributed mainly to differences in the sediment grain-size composition. Percent sand was significantly higher in the one-year trays at Station 2 than in any of the other trays at either station.

The second set of six-month trays, deployed between April and November 1985, sampled a different fauna than was recorded over the same time period in 1984. For example, spionids and Capitella-like species were both much more common in 1984 than in 1985. The sediment-dwelling tunicate Dicarpa simplex and the ectoparasitic isopod Gnathia sp. were common in 1985 but absent in 1984.

Epifauna

A total of 90,282 m² of the seafloor, spanning a depth range of 1756 to 2353 m, was viewed for this study. The 44-km-long transect was centered on the 2100-m isobath and transversed a series of valleys and ridges covering a depth range of 1901 to 2353 m. The depth range covered by the circle transect (see Figure 2) extended from 1950 to 2324 m. Data were developed for individual 35-mm frames. Each transect was divided into 30-picture sample intervals and abundances were standardized to number of individuals per 100 m².

Data analysis included the determination of faunal abundance and species composition with depth; the determination of density, faunal composition, and trophic structure with topography; and determination of epifaunal community parameters with depth and topography. Both classification (percent similarity) and ordination (reciprocal averaging) were used to evaluate patterns in epifaunal community structure.

Transect and classification analysis indicated trends in epifaunal trophic structure and species composition that were related to a combination of depth and topography. Faunal density was highest between 1800 and 1900 m and moderate between 1900 and 2350 m. Densities also followed a pattern of highest abundance on shallow ridges and in flat valleys, with lowest abundances on steep slopes and in deep valleys. Five species accounted for the majority of the fauna (Figures 9 and 10). The two most abundant species, the brittle star Ophiomusium lymani and an unnamed cerianthid anemone, were present in maximum abundances between 1800 and 1900 m. The highest densities of the three remaining species, the sea pen Kophobelemnon stelliferum, the urchin Echinus affinis, and the soft coral Acanella arbuscula, were found below 2000 m. Throughout most of the transect, densities were generally similar for each of the sampling periods. Density of total megafauna was highest on topographic highs and lowest in valleys. Peaks in density frequently reflected the abundance of one or two of the five most common species. Two species, the deposit-feeding ophiuroid O. lymani and the filter-feeding cerianthid anemone, were common throughout most of the along-isobath transect area surveyed. Both of these species were found in highest densities in topographic highs. Echinus affinis was most abundant in steep areas, K. stelliferum preferred flat areas, and A. arbuscula preferred shallow flat ridges.

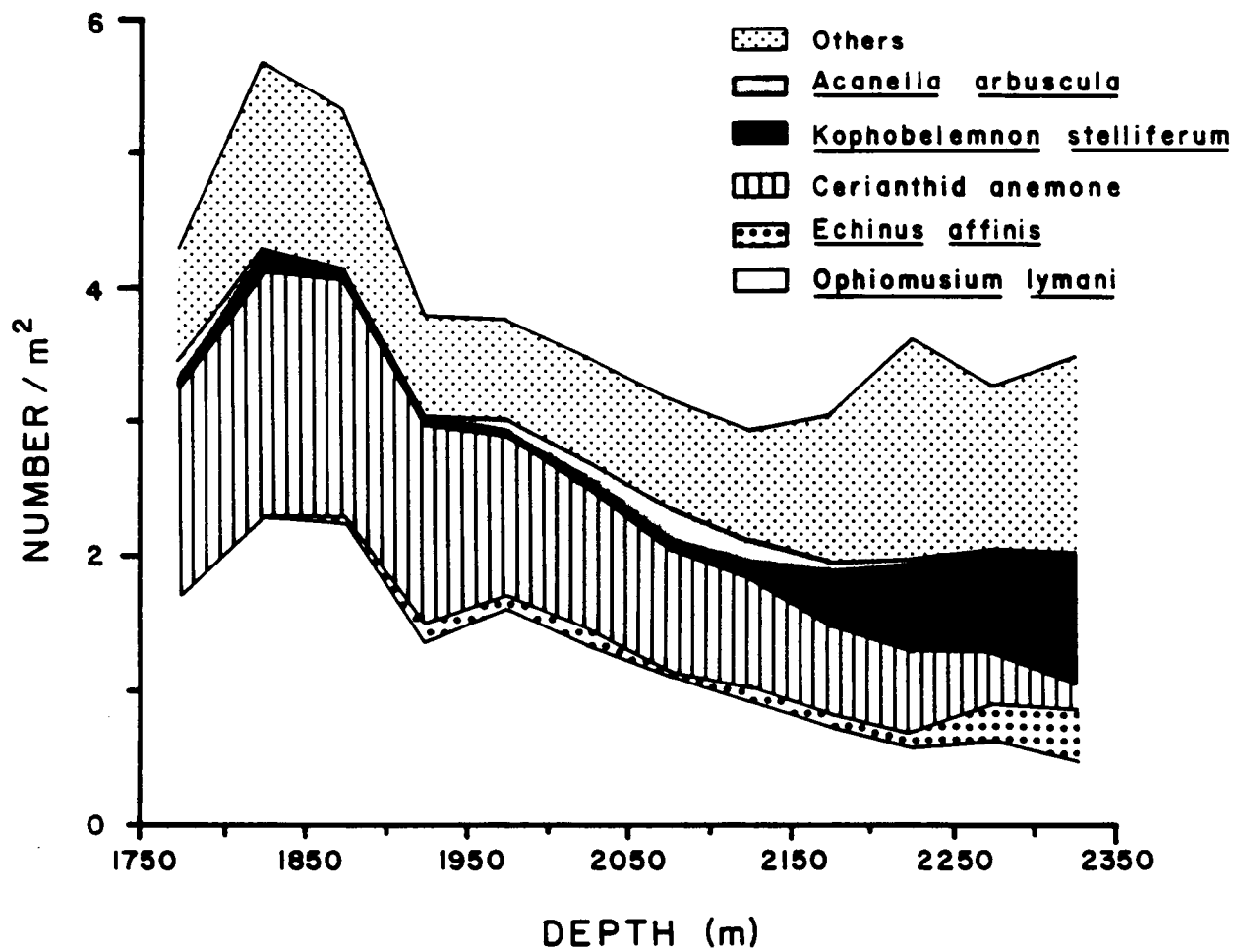

Figure 9. Density of Total Megafauna and Five Selected Species With Depth.

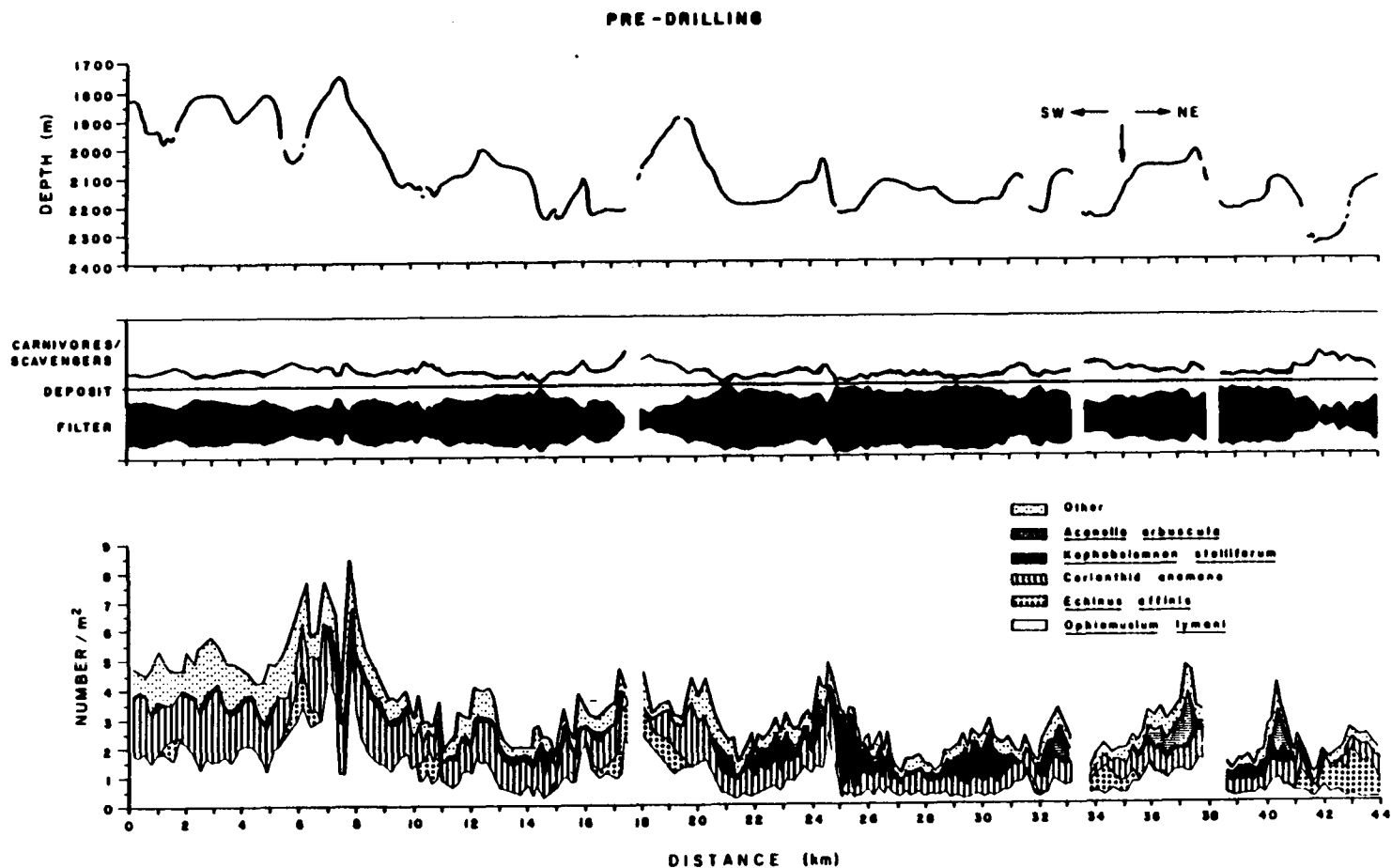

Figure 10. Depth, Trophic Type, and Abundance of Total Megafauna and Five Selected Species from the Camera-Sled Tows Along the 44-km Transect in April-May 1984. The Relative Proportion of Deposit Feeders Is Represented by the Clear Envelope Around the Center Line; the Relative Proportions of Carnivores/Scavengers and Filter Feeders Are Represented by the Shaded Areas Above and Below the Line, Respectively. The Arrow Marks the Location of Station 1.

Filter feeders and deposit feeders accounted for 97 to 100 percent of the fauna seen; whereas carnivores or scavengers as a group accounted for less than 3 percent (Figure 10). Shifts in the relative proportion of the two dominant feeding types followed the general pattern of a higher proportion of filter feeders on ridges and in flat valleys, and a higher proportion of deposit feeders on steep slopes and in deep valleys. These shifts in dominant trophic type usually reflected a decrease in the abundance of one species with a concurrent increase in the abundance of another species. The trophic pattern was generally quite consistent among the three sampling dates.

Community analysis indicated that faunal composition was related to a combination of depth and topography, with few discernible differences among sampling dates (Figure 11). The range of mean depths of areas within each of the three major clusters overlaps considerably, but further analyses indicated that areas in clusters 1 and 3 represent extreme flat and steep regions, respectively, and those in cluster 2 encompass the range between the two extremes. Faunal differences among the clusters and groups of areas defined by classification analysis were usually attributable to the presence or absence of one or two species. The results obtained by ordination analysis suggest that much of the cluster pattern represents areas of faunal transition between the extremes of high ridges and deep valleys, rather than well-defined faunal boundaries.

These shifts in trophic type, and the underlying changes in the fauna, may result from the interaction of bottom topography and currents, which can affect nutrient input. As a result of the along-slope flow of the Western Boundary Undercurrent, tops of ridges and flatter areas may experience higher current velocities and concomitantly greater suspended particulate matter than would deeply incised valleys. Higher numbers of filter feeders would therefore be supported in such areas. Conversely, decreased flow rates over topographic lows could result in the settling of suspended particles, therefore providing increased food supplies for deposit feeders. This situation could explain the high densities of E. affinis observed in valleys.

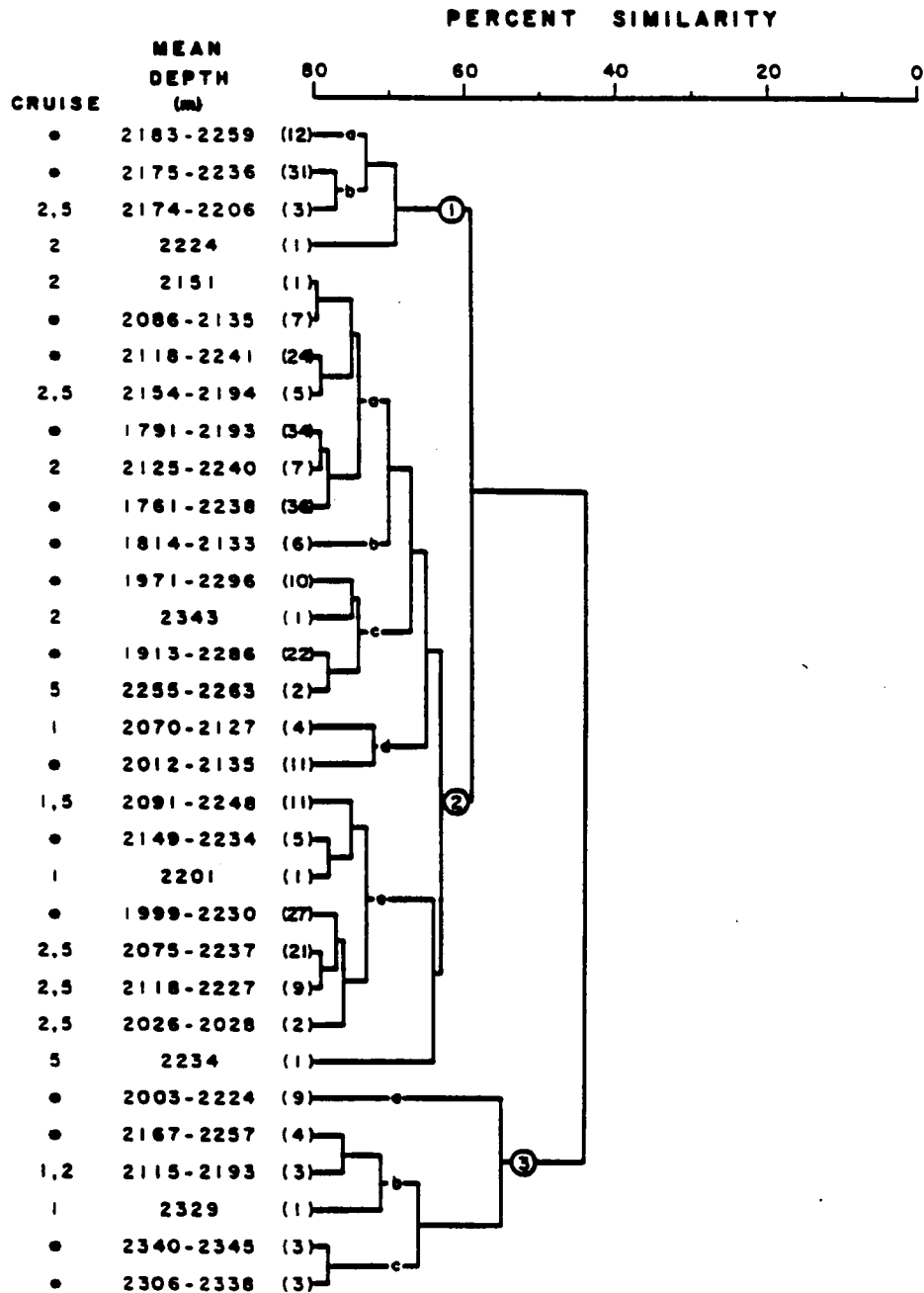

Figure 11. Hierarchical Classification of Sample Areas from Camera-Sled Tows Along the 44-km Transect. The circled Numbers and Corresponding Letters Represent Major Clusters and Groups of Areas, Respectively. The Following Information Is Presented for the Areas in Each Leg of the Dendrogram: Cruise (1=Pre-Drilling, 2=2 Months After Drilling, 5=14 Months After Drilling, and *=All Three Cruises), Depth Refers to the Range of Mean Depths of the Sample Areas, and the Number in Parentheses Represents the Number of Sample Areas Included in the Leg.

CHEMICAL COMPOSITION OF SEDIMENTS AND TISSUES

Sediments

Sediments were first extracted with methanol followed by a methanol:methylene chloride mixture. The extracts were then screened for petroleum residues by synchronous scanning UV/fluorescence spectrophotometry (UV/F), which provides a semiquantitative characterization of the aromatic hydrocarbon distributions. This method was used in conjunction with station location to identify those samples that would be further analyzed by high resolution gas chromatography (GC). Extracts from selected stations were then combined and fractionated by column chromatography to isolate saturated and aromatic hydrocarbons. Individual compounds were quantified using capillary gas chromatography with flame ionization detection (GC/FID) for the saturates and capillary gas chromatography/mass spectrometry (GC/MS) for the aromatics.

Hydrocarbon concentrations in sediments as determined by UV/F varied between 7.11 and 131 $\mu\text{g/g}$ (parts per million) dry weight. Typical UV/F spectra for surface sediment, drilling muds, and cuttings are presented in Figure 12. The spectra of all the sediment samples were dominated by broad spectral bands centering at approximately 312 nm, 355 nm, and 425 nm. By contrast, the spectra of the drilling muds and cuttings were dominated by spectral bands at 312 nm and 355 nm because of the prevalence of lower molecular weight aromatic compounds in these samples.

Total hydrocarbon concentrations as determined gravimetrically and by GC/FID ranged between 2.9 and 52.9 $\mu\text{g/g}$ dry weight, with roughly comparable contributions from saturated and aromatic hydrocarbons at most stations. The highest concentrations were found at Station 13, but elevated concentrations also occurred at Stations 2, 10, and 12. Total concentrations of polyaromatic hydrocarbons (PAH) ranged between 66 and 1157 ng/g (parts per billion) dry weight, and in general, paralleled the total hydrocarbon concentrations, with the lowest values found at Stations 10 and 12 and the highest values found at Stations 11, 13, and 14.

The concentrations appear similar to, but higher than, values found in earlier studies in same geographic area (Farrington and Tripp, 1977; Smith et al., 1979) and are also higher than concentrations found in sediments at similar depth regimes in the U.S. North

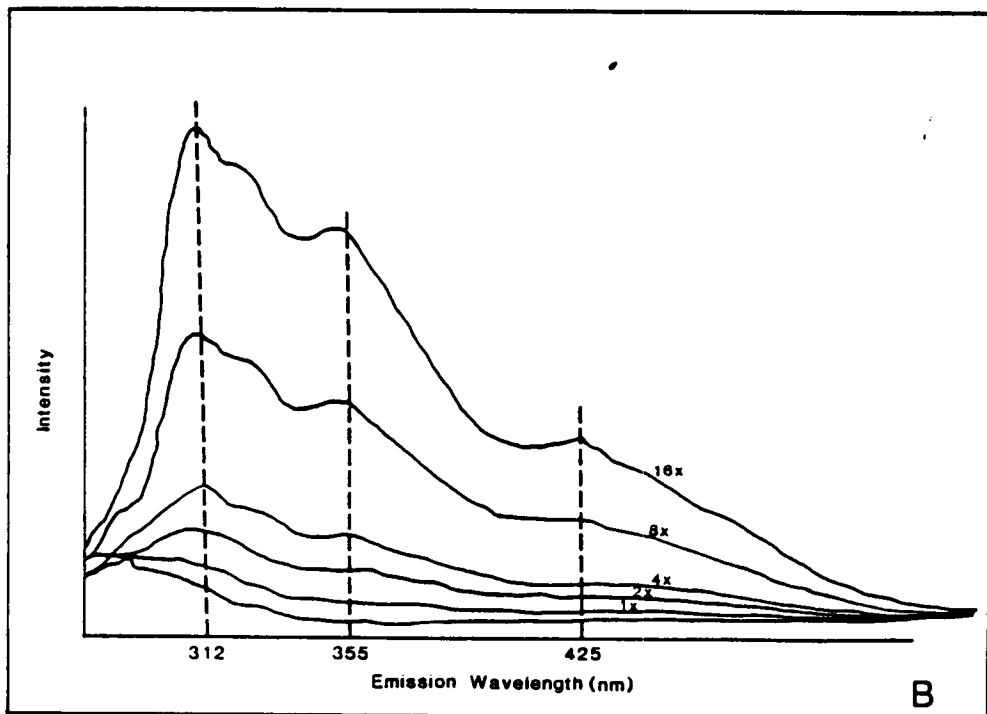
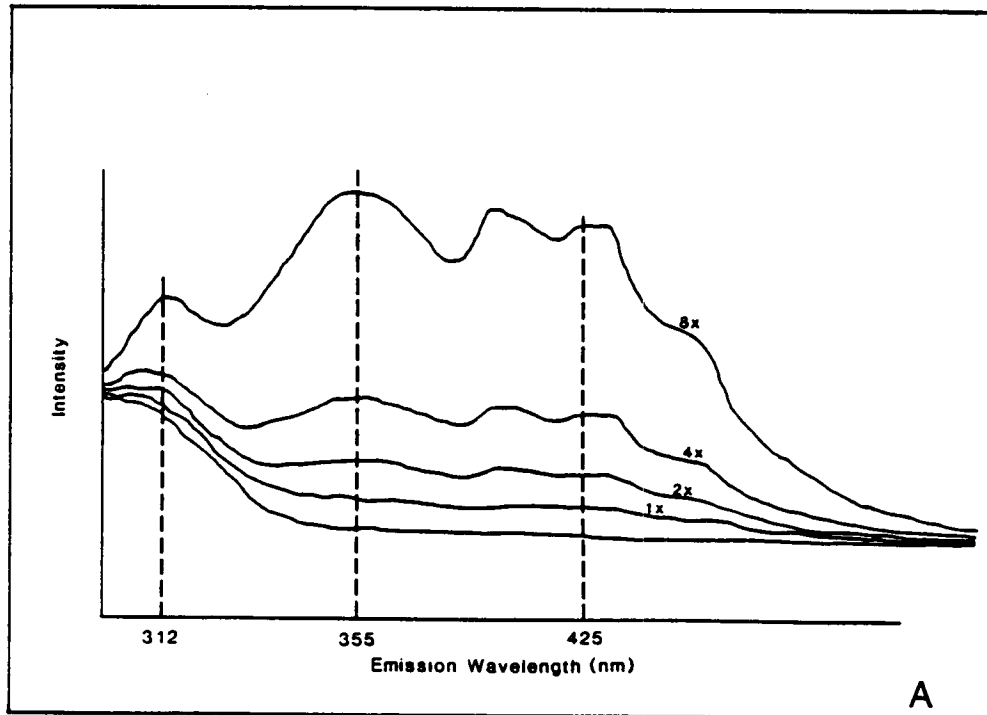

Figure 12. Representative UV/F Spectra of Sediment, Drilling Mud, and Drill Cutting Samples: A. Sediments from Station 7, Cruise Mid-1. B. Composite of Drilling Muds Discharged at Block 372.

Atlantic study area (Maciolek et al., 1987). UV/F, GC/FID, and GC/MS data for the stations for which there are data for all six cruises indicate that there was no change in hydrocarbon concentrations between sampling dates. Results of the UV/F analyses indicated that the variability in mean hydrocarbon concentration at any given station between sampling dates was similar to the variability between replicates for a single sampling time.

Tissues

Brittle stars (Ophiomusium lymani) and sea urchins (Echinus affinis) were analyzed directly by GC/FID and GC/MS to determine hydrocarbon content and composition and were also analyzed by atomic absorption spectroscopy (AAS) for a targeted suite of trace metals.

Hydrocarbon concentrations in the fauna ranged between 27.4 and 163.1 µg/g wet weight. GC/MS analyses of the six faunal samples revealed no detectable PAH compounds in any sample collected on Cruise Mid-1 or Cruise Mid-2. However, use of a larger sample size for the Cruise Mid-5 analyses allowed the lowering of the detection limits for individual PAH. The levels of PAH in these samples were uniformly low.

With the exception of aluminum, iron, and zinc, the elements present in the tissue samples were quite low and approached method detection limits for barium, cadmium, chromium, copper, nickel, vanadium, and mercury. The tissue analyses represent whole body analyses, and the higher levels of aluminum, iron, and zinc may represent material associated with ingested sediment.

Total Organic Carbon, Hydrogen, and Nitrogen

Frozen sediment samples were thawed, homogenized, and prepared for analysis by first dissolving the carbonate carbon with sulfurous acid. This treatment was followed by a wash with organic-free water. Samples were analyzed at WHOI on a Perkin-Elmer Model 240 Elemental Analyzer.

Sediments, particularly those from Station 12, were apparently much higher in carbonate carbon than were sediments from the continental shelf (Maciolek-Blake et al., 1985). Total organic carbon content ranged from 0.52 percent (Station 12) to 2.00 percent (Station 13). Nitrogen content ranged from 0.06 percent (Station 12) to 0.25 percent (Station 13). Carbon/nitrogen ratios averaged 7.95 for all stations over all cruises with a standard deviation of 0.62. All C/N values fell between 6 and 10.

Sediment Grain Size

Sediment samples remained frozen until analysis. Pretreatment of sediments included an overnight soak and 30-min ultrasonification in 80 ml of 0.5 percent solution of Calgon and 2 ml of 30 percent H₂O₂. Silt and clay fractions were analyzed by standard pipette procedures at whole-phi intervals (Folk, 1974). Sand fractions of samples with greater than 10 percent sand were sieved at whole-phi intervals on a Ro-Tap shaker.

Variability among samples collected at a single station was typically low within one sampling date; however, at some stations the within-station range equaled that observed on a regional scale. In general, sediments were dominated by silts and clays, and sand content increased with depth along the transect from Station 11 (1515 m) to Station 1 (2100 m) to Station 12 (2500 m) and from Station 13 (1613 m) to Station 10 (2095 m). This increase may reflect diminishing down-slope transport of terrigenous fine-grained material and increasing relative importance of pelagic sedimentation of sand-sized foraminiferal tests. The range of sediment textures found at the other stations probably reflects placement of stations in different depositional environments with respect to sediment transport in and around canyons.

IMPACTS OF DRILLING

The major objective of this program was to determine the impacts, if any, of exploratory drilling operations, in particular, the discharge of drilling muds and drill cuttings, on the benthic fauna of the U.S. Mid-Atlantic slope and rise. Drilling started in Block 372 in 2120 m of water on May 26, 1984, and the monitoring effort was centered around that site. The well was plugged and abandoned on July 9, 1984, having been completed to a depth of 4679 ft (1426 m) below the mud line. The drill ship, Discoverer Seven Seas, then moved to Block 93 in 1528 m of water and began drilling there on July 12, 1984. Drilling in Block 93 continued to a depth of 12,727 ft (3879 m) below the mud line. The well was plugged and abandoned on November 4, 1984. In the series of six cruises, one pre-drilling and five post-drilling sample sets were collected at Block 372. One pre-drilling, one during-drilling, and four post-drilling sample sets were collected at Station 13 in Block 93; one pre-drilling and three post-drilling sample sets were collected at Station 14.

Physical Impacts

A total of 4144 barrels (668,843 L) of drilling mud and 541 barrels (85,987 L) of drill cuttings were discharged from the drill ship during drilling of the well in Block 372. The drilling mud inventory for this well contained 511 metric tons (mt) of drilling mud solids, representing nine major drilling mud ingredients. Included were 96.5 mt of barite (18.9 percent of mud solids) and 1.75 mt of chrome lignosulfonate. Probably no more than 50 percent of the total solids in the drilling mud inventory were actually discharged to the ocean. The remainder was either retained on board the ship or left in the hole.

A total of 40,387 barrels (6,421,020 L) of drilling mud and 2506 barrels (398,454 L) of drill cuttings were discharged from the drill ship during drilling of the well in Block 93. The drilling mud inventory for this well was not available from the operator, but probably was qualitatively similar to the inventory for the Block 372 well.

Physical evidence of drilling-related activities was minimal in the vicinity of the Block 372 drill site. No cuttings piles were noted in the photographic analysis, although discarded plastic pipe casings were seen in the post-drilling (Cruise Mid-2) camera tow.

One sediment grain-size sample collected at Station 1 on Cruise Mid-2 contained large flakes of a brittle, pale-yellow material that at first was thought to be drill cuttings. Visual inspection of replicates from Stations 2, 3, and 10 revealed the presence of this material at Stations 2 and 3, in addition to Station 1. This material is now believed to be a calcareous claystone derived from recently eroded outcrops of Eocene age.

Chemical Impacts

There was little variation in the concentrations of heavy metals in surficial sediments among stations or at any station for the first four sampling cruises, with one exception (Bothner et al., 1987). In one replicate sample from Station 1 on Cruise Mid-3 (November/December 1984), the concentration of barium was as much as 13 percent higher in the top 4 cm than in the deeper core sediments. In one replicate from Cruise Mid-6, the top sediments were 20 percent higher in barium concentration. Barium, because it is usually abundant in drilling muds and is both dense and very insoluble, is frequently used as a tracer of the environmental fate of discharged drilling muds. Bothner et al. (1987) presented several lines of evidence in support of the premise that the elevation in the concentration of barium in sediments at Station 1 after drilling was due to the accumulation of drilling mud solids. However, the increase in barium concentration was small, from a pre-drilling mean of 422 ppm to a concentration of 493 ppm in the one Cruise Mid-3 replicate sample and 555 ppm in one Cruise Mid-6 sample, and these values are within the 580 ppm worldwide average for marine shales (Krauskopf, 1967). The concentrations of barium or other metals in sediments did not increase between pre- and post-drilling surveys at any other station along the two transects through the Block 372 drill site. In addition, there was no change in the concentrations of barium or other metals in surficial sediments at the two stations near the Block 93 drill site, despite the fact that nearly 10 times more drilling mud and cuttings were discharged at Block 93 than at Block 372. The strongest chemical signal from drilling mud was the collection of discrete particles of barite in several sediment traps placed within the upper 850 m of the water column at a mooring 2.8 km southwest of Station 1 (Bothner et al., 1987).

Given the great depth (>2000 m) of the water and the rate of sinking of barite-sized particles, most of the drilling mud solids discharged from the ship were expected to be

transported tens of kilometers away before settling on the bottom. However, during drilling of the surface hole (spudding in) and setting of the surface casing, the riser system is not in place and drilling mud is not returned to the ship for recycling down-hole. Instead, the spud mud and drill cuttings are discharged directly to the bottom. Because spud mud may contain up to 50 lb barite per barrel (Ayers et al., 1983), it is possible that the barium that accumulated in surficial sediments at Station 1 was derived from spud mud discharged directly to the bottom. Conversely, the sediment traps deployed by Bothner et al. (1987) were set out for a period of 99 days beginning June 21, 1984. This time period included the last 18 days of the drilling operations at Block 372. Bothner et al. (1987) concluded that large particles of barite fell individually through the water column at speeds predicted by a model based on Stokes Law; the presence of fine-grained barite is more difficult to explain, but presumably these particles could have been transported after incorporation into copepod fecal pellets.

Samples of drilling muds and cuttings were collected from the drill ship during drilling operations at both Block 93 and Block 372. The hydrocarbon composition of these samples was determined and compared to the hydrocarbon composition of the natural sediments. The concentration of total hydrocarbons in the samples of drilling muds and cuttings ranged from 91.9 to 918 ppm as measured gravimetrically. Hydrocarbon concentrations in the surficial sediments ranged from 5.7 to 52.9 ppm as measured gravimetrically. The highest concentrations in sediments occurred at Station 13, but elevated values were also found at Stations 5 and 11. The lowest concentrations of hydrocarbons in sediments were found at Stations 2, 10, and 12. The gas chromatograms of the alkane and aromatic hydrocarbon fractions of the sediment extracts revealed that a majority of the hydrocarbons present were of biogenic or pyrogenic origin and not from petroleum. There were no geographic or temporal trends in sediment concentrations of total hydrocarbons or resolved polycyclic aromatic hydrocarbons (the best markers of petroleum discharges) that could be attributed to drilling discharges.

Samples for heavy metal and hydrocarbon analysis of the brittle star Ophiomusium lymani and the sea urchin Echinus affinis were collected from three stations on Cruise Mid-1, from one station on Cruise Mid-2, and from two stations on Cruise Mid-5. With the exception of aluminum, iron, and zinc, the elements present in the tissue samples were quite low and approached the detection limits for the methods used. Concentrations of

barium, chromium, or other metals did not increase in the tissues of the sea urchins or brittle stars from either Stations 1 or 4 between the pre-drilling and the post-drilling cruises. There was no consistent relationship between the concentration of any metal in sediments from a particular station at a particular sampling time and the concentration of that metal in the tissues of echinoderms residing in that sediment.

Hydrocarbon concentrations in the tissues of these animals ranged between 27.4 and 163.1 ug/g wet weight. The gas chromatograms (GC) of hydrocarbons in the tissue extracts were dominated by high molecular weight saturates of biogenic origin. There was no clear relationship between the concentration of hydrocarbons in the tissues of the echinoderms and in the sediments in which they resided. There was no evidence of bioaccumulation of either heavy metals or hydrocarbons from discharged drilling mud and cuttings.

Biological Impacts

The biological parameters measured in this program were the community structure of the infaunal benthos and the composition of the epifaunal megabenthos. The deep-sea benthic infauna are thought to be very sensitive to burial (Jumars, 1981). Therefore, the accumulation of even a small amount of drilling mud and cuttings solids (a millimeter or so) on the sediment surface might be expected to have a deleterious effect on the fauna. Several measures of diversity were evaluated, including Hurlbert rarefaction and the Shannon-Wiener index. Diversity at all stations was uniformly high over all sampling seasons. It was hypothesized that any sudden, unnatural disturbance of the deep-sea communities would result in a sharp drop in diversity; such a decrease was not seen at any station (Table 6). The changes in diversity that were seen, e.g., at Station 1, were small and are not considered to be significant. At Station 1, the Shannon diversity values increased from 6.16 on the pre-drilling Cruise Mid-1 to 6.24 on Cruise Mid-6. The Hurlbert rarefaction values decreased from 154 to 150 species per 1000 individuals over the same time period. At Station 14, the Shannon diversity dropped from 6.34 on Cruise Mid-1 to 6.01 on Cruise Mid-6, but the Hurlbert rarefaction values did not change over the same time period.

TABLE 6. CHANGES OVER TIME IN HURLBERT RAREFACTION VALUES FOR SPECIES PER 100 AND 1000 INDIVIDUALS AND IN SHANNON-WIENER DIVERSITY (H') AT THE DRILL-SITE STATIONS 1 AND 14 AND STATIONS LOCATED 2 KM TO THE SOUTHWEST.

	<u>Drill-Site Station 1</u>			<u>Station 2</u>		
	<u>spp/100</u>	<u>spp/1000</u>	<u>H'</u>	<u>spp/100</u>	<u>spp/1000</u>	<u>H'</u>
Cruise Mid-1	51.9	153.8	6.16	50.9	152.6	6.09
Cruise Mid-2	49.3	135.9	5.99	53.6	146.1	6.25
Cruise Mid-3	48.7	138.9	5.94	54.1	153.4	6.30
Cruise Mid-4	48.5	128.0	5.95	52.1	142.8	6.18
Cruise Mid-5	49.0	134.4	5.94	52.2	154.2	6.19
Cruise Mid-6	53.8	149.6	6.24	55.8	153.4	6.36
	<u>Drill-Site Station 14</u>			<u>Station 13</u>		
	<u>spp/100</u>	<u>spp/1000</u>	<u>H'</u>	<u>spp/100</u>	<u>spp/1000</u>	<u>H'</u>
Cruise Mid-1	55.1	166.5	6.34	50.2	163.3	6.07
Cruise Mid-2	NS	NS	NS	50.8	152.3	6.08
Cruise Mid-3	NS	NS	NS	50.3	164.7	6.11
Cruise Mid-4	57.3	177.2	6.48	51.7	157.2	6.10
Cruise Mid-5	52.1	161.0	6.08	51.2	157.1	6.09
Cruise Mid-6	51.8	167.2	6.01	51.1	156.4	6.12

NS = Not sampled.

Based on both the NESS and Bray-Curtis similarity measures, samples collected at Station 1 on the first, pre-drilling, cruise clustered separately from samples collected on the post-drilling cruises. These results may be due to differences in the abundances of certain species over time. For example, the density of the polychaete Tharyx sp. 1 was significantly lower in Cruise Mid-4 (post-drilling) samples than in Cruise Mid-1 (pre-drilling) samples. However, the density of this species was not significantly different from densities recorded at the majority of stations on any particular sampling date. Similarly, the polychaete Auospio dibranchiata had significantly different densities at Station 14, the drill site station in Block 93, in May 1984 and May 1985. The abundance of this species, which is dominant at the majority of stations along the 2100-m isobath, increased between the two sampling dates, and the change is not considered to be a harmful effect of drilling.

Pre-drilling samples collected at Station 14, the drill site in Block 93, were highly similar to samples collected a year later (Cruise Mid-4). Samples collected on Cruise Mid-6, however, were highly dissimilar to other replicates collected at this station; this dissimilarity was apparent when only the polychaete fauna was evaluated as well as when the total fauna was evaluated. No statistically significant changes in sediment grain-size composition were detected at Station 14; therefore, it is difficult to account for the dissimilarity of this one sample set.

A much larger amount of drilling mud and cutting solids accumulated in surficial sediments near the drilling site in Block 312 in 80 m of water on Georges Bank, as indicated by increases in the concentration of barium in surficial sediments (Bothner et al., 1985). In that study, as in this one, there were no measurable changes in the benthic infaunal community structure that could be attributed to the drilling discharges (Maciolek-Blake et al., 1985).

Trays filled with azoic sediment were placed at Stations 2 and 4 in order to determine the rate of recolonization of disturbed sediments. The experiment was designed to determine if there were any differences in recolonization rates between stations near the drill site (Station 2) and up-current of the site (Station 4). After the first six-month period, the faunal recolonization was very similar at both stations, but after one year, significantly greater numbers of individuals had settled at Station 4 in comparison with Station 2. This difference is most likely due to the different percentages

of sand in the sediments in the trays. At Station 2, the percentage of sand in the one-year trays was about six times higher than in the one-year trays from Station 4. There were no differences in levels of trace metals in the tray sediments compared to the range of values obtained at the slope stations where the sediment was originally collected (Bothner et al., 1987).

Transect and classification analysis of data collected from camera-sled tows indicated trends in epifaunal trophic structure and species composition that were related to a combination of depth and topography. With one exception, only minor localized faunal differences between pre- and post-drilling transects were discerned. The one change in epifauna that may have been related to the drilling activity in Block 372 was seen in the valley 2 km downslope of the drill site. This area supported a very high abundance of the sea pen Kophobelemnon stelliferum prior to drilling. Two months after drilling had been completed, very reduced densities of this organism were found in the same area, but 14 months later somewhat higher abundances were found. Because the paths of all three camera-sled tows overlapped in this area, it is possible that the observed decline in the abundance of K. stelliferum during the first post-drilling tow was related to the drilling activity. However, this difference may be attributable to another factor, unrelated to drilling. Data on sediment texture developed during the present study indicate that a mass movement of sediment occurred between the pre-drilling and first post-drilling cruises in the area upslope of this region. This event may have buried many of the sea pens or clogged their filtering apparatuses, thereby accounting for the observed decrease in their abundance. If the decrease in K. stelliferum in the valley downslope of the drill site was indeed related to drilling activity, it appears to have been relatively short-lived, because higher densities were found 14 months after drilling had been completed. Other faunal changes between the post-drilling tows were minor, and were usually related to slight variations in the paths of the tows. In conclusion, with the possible exception of a small area downslope of the drill site, it does not appear that the exploratory drilling in Block 372 had a significant impact on the epifaunal composition of the surrounding area.

LITERATURE CITED

- Ayers, R.C., Jr., T.C. Sauer, Jr., and P.W. Anderson. 1983. The generic mud concept for offshore drilling for NPDES permitting. Proc. IADC/SPE 1983 Drilling Conference, New Orleans, LA. Society of Petroleum Engineers, Dallas, TX. No. 11399, pp. 327-336.
- Blake, J.A., B. Hecker, J.F. Grassle, B. Brown, M. Wade, P.D. Boehm, E. Baptiste, B. Hilbig, N. Maciolek, R. Petrecca, R.E. Ruff, V. Starczak, and L. Watling. 1987. Study of biological processes on the U.S. South Atlantic slope and rise. Phase 2. Final Report prepared for U.S. Dept. of the Interior, Minerals Management Service, Washington, D.C. 414 pp. + Appendices A-M.
- Boesch, D.F. 1977. Application of numerical classification in ecological investigations of water pollution. U. S. Department of Commerce, NTIS PB-269 604. EPA-60013-77-033. 114 pp.
- Bothner, M.H., R.R. Rendigs, E. Y. Campbell, M.W. Doughten, C.M. Parmenter, C.H. O'Dell, G.P. DiLisio, R.G. Johnson, J.R. Gillison, and N. Rait. 1985. The Georges Bank Monitoring Program: Analysis of trace metals in bottom sediments during the third year of monitoring. Final report submitted to the U.S. Department of the Interior, Minerals Management Service under Interagency Agreement No. 14-12-0001-30153. 99 pp.
- Bothner, M.H., E.Y. Campbell, G.P. DiLisio, C.M. Parmeter, R.R. Rendigs, J.R. Gillison, W. Dangelo and J.A. Commeau. 1987. Analysis of trace metals in bottom sediments in support of deepwater biological processes studies on the U.S. Mid-Atlantic Continental Slope and Rise. Final Report submitted to U.S. Department of the Interior, Minerals Management Service, March 31, 1987. Interagency Agreement No. 14-12-0001-31097. 82 pp.
- Brown, B. 1985. Ch. 4. Biomass. In: Georges Bank Benthic Infauna Monitoring Program Final Report, prepared for the U.S. Dept. of Interior, Minerals Management Service by Battelle New England Marine Research Laboratory and Woods Hole Oceanographic Institution, pp. 97-120.
- Dinet, A., D. Desbruyeres, and A. Khripounoff. 1985. Ch. 6. Abondance des peuplements macro- et meiobenthiques: repartition et strategie d'enchantillonnage. In: Peuplements profonds du Golfe de Gascogne - Campagnes Biogas, L. Laubier, and C. Monniot (eds.), IFREMER, Brest, pp. 121-142.
- Farrington, J.W. and B.W. Tripp. 1977. Hydrocarbons in western North Atlantic surface sediments. *Geochim. et Cosmochim. Acta* 41:1627-1641.
- Folk, R.L. 1974. Petrology of Sedimentary Rocks. Hemphill Publishing Company, Austin, Texas. 182 pp.
- Gaufin, A.R., E.K. Harris and H.J. Walter. 1956. A statistical evaluation of stream bottom sampling data obtained from three standard samplers. *Ecology* 37: 643-648.

- Grassle, J.F. and W.L. Smith. 1976. A similarity measure sensitive to the contribution of rare species and its use in investigation of variation in marine benthic communities. *Oecologia* 25:13-22.
- Grassle, J.F., L.S. Brown-Leger, L. Morse-Porteous, R. Petrecca, and I. Williams. 1985. Deep-sea fauna of sediments in the vicinity of hydrothermal vents. *Biol. Soc. Washington Bull.* 6:443-452.
- Grassle, J.F. and L. Morse-Porteous. In press. Macrofaunal colonization of disturbed deep-sea environments and the structure of deep-sea benthic communities. *Deep-Sea Res.*
- Hessler, R.R. and H.L. Sanders. 1967. Faunal diversity in the deep sea. *Deep-Sea Res.* 14: 65-78.
- Hill, M.O. 1973. Reciprocal averaging: an eigenvector method of ordination. *J. Ecol.* 61:237-249.
- Hill, M.O. 1974. Correspondence analysis: a neglected multivariate method. *J. Royal Stat. Soc., Ser. C.* 23:340-354.
- Hurlbert, S.H. 1971. The nonconcept of species diversity: a critique and alternative parameters. *Ecology* 52:577-586.
- Jumars, P.A. 1981. Limits in predicting and detecting benthic community responses to manganese module mining. *Marine Mining* 3:213-229.
- Krauskopf, K.B. 1967. Introduction to Geochemistry. McGraw-Hill, New York. 721 p.
- Khripounoff, A., D. Desbruyeres, and P. Chardy. 1980. Les peuplements benthiques de la faille Vema: donnees quantitatives et bilan d'energie en milieu abyssal. *Oceanologica Acta* 3: 187-198.
- Maciolek-Blake, N., J.M. Neff, and J.F. Grassle (eds.). 1985. Georges Bank Benthic Infauna Monitoring Program: Final Report for the Third Year of Sampling. Prepared for U.S. Department of the Interior, Minerals Management Service, Washington, D.C. under contract No. 14-12-0001-29192. ii + 333 pp.
- Maciolek, N.J., J.F. Grassle, B. Hecker, B. Brown, J.A. Blake, P.D. Boehm, R. Petrecca, S. Duffy, E. Baptiste, and R.E. Ruff. 1987. Study of biological processes on the U.S. North Atlantic slope and rise. Final Report prepared for U.S. Dept. of the Interior, Minerals Management Service, Washington, D.C., 358 pp. + Appendices A-L.
- Maurer, D. and R.L. Wigley. 1984. Biomass and density of macrobenthic invertebrates on the U.S. continental shelf off Martha's Vineyard, MA., in relation to environmental factors. NOAA Tech. Rpt., NMFS SSRF-783. 24 pp.
- Rex, M.A. 1983. Geographic patterns of species diversity in the deep-sea benthos. In: The Sea, Vol. 8, G.T. Rowe (ed.), John Wiley and Sons, pp. 453-472.

- Rowe, G.T. 1983. Ch. 3. Biomass and production of the deep-sea macrobenthos. In: Deep-Sea Biology, G.T. Rowe (ed.), John Wiley & Sons, New York, pp. 97-121.
- Smith C.L., C.W. Su, and W.G. MacIntyre. 1979. Hydrocarbon distribution and concentration, Chapt. 14, Section 1, Vol. IIB. In: Middle Atlantic Outer Continental Shelf Environmental Studies, Chemical and Biological Benchmark Studies, Final Report. Contract No. AA550-CT6-62, Bureau of Land Management, New York OCS Office, New York.
- Smith C.R., P.A. Jumars, and D.J. DeMasters. 1986. In situ studies of megafaunal mounds indicate rapid sediment turnover and community response at the deep-sea floor. *Nature* 323:251-253.
- Smith, W.L., J.F. Grassle, and D. Kravitz. 1979. Measures of diversity with unbiased estimates. In: Ecological Diversity in Theory and Practice, J.F. Grassle, G.P. Ptil, W.L. Smith and C. Taille (eds.), International Cooperative Publishing House, Fairland, Maryland, pp. 177-191.
- Sokal, R.R. and F.J. Rohlf. 1969. Biometry. Freeman Press, San Francisco. 776 pp.
- Thistle, D., J.Y. Yingst, and K. Fauchald. 1985. A deep-sea benthic community exposed to strong near-bottom currents on the Scotian Rise (western Atlantic). *Mar. Geol.* 66:91-112.