

Assessing the hidden Marine cryptic benthic Biodiversity of Coral Reef ecosystems of Grande Island, Goa

Submitted to



Submitted by



August 2023

Contents

Summary.....	6
1. Introduction	7
1.1. Scope of Work.....	9
2. Methodology.....	10
2.1. Study Area	10
2.2. Underwater Survey- LIT Method.....	11
2.3. ARMS Deployment	12
2.4. Taxonomic Identification.....	15
2.5. Non-Invasive Biodiversity Monitoring.....	15
3. Results.....	16
3.1. Line Intercept Transect (LIT) Survey.....	16
3.2. Taxonomic Assignment.....	19
3.3. Non-Invasive Biodiversity Assessment- Water sample.....	41
3.3.1. NGS Raw Sequences Submitted to NCBI.....	41
3.3.2. Quality Assessment of the Sequences Generated.....	41
3.3.3. Taxonomic Assignment	42
4. Discussion	43
5. Outcomes and Proposed Future Management Practices.....	46
References.....	47
Annexure I.....	50
Annexure II.....	53

List of Tables

Table 1: Underwater Survey sites with coordinates and date	12
Table 2: Autonomous Reef Monitoring System (ARMS) deployment	14
Table 3: Average percent cover of Live Corals, Dead Corals and Macro Algae of the Grande Island.....	18
Table 4: Details of sponge samples collected, taxonomy identification and voucher specimen .	20
Table 5: Sponge sample with their spicules isolated, Species ID and Voucher specification	21
Table 6: Molecular Taxonomy based on the Cytochrome Oxidase Subunit 1 gene.....	23
Table 7: The details of Sequence Read Archive (SRA) submission in the NCBI for the generated Grande island dataset.	41

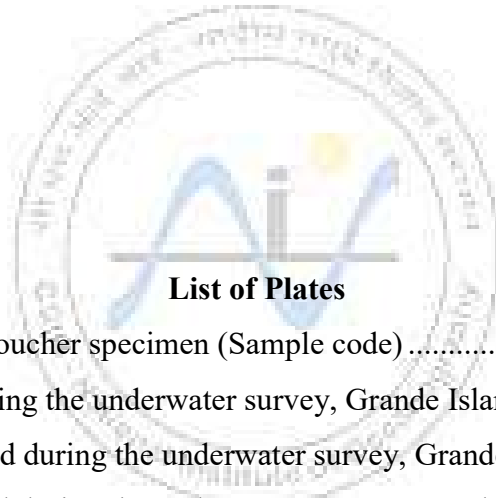

List of Plates

Plate 1: Coral nubbins for voucher specimen (Sample code)	25
Plate 2: Fishes recorded during the underwater survey, Grande Island.....	30
Plate 3: Macroalgae recorded during the underwater survey, Grande Island	34
Plate 4: Soft Corals recorded during the underwater survey, Grande Island	36
Plate 5: Other Fauna recorded during the underwater survey, Grande Island	37
Plate 6: Corals recorded during the underwater survey, Grande Island.....	39

List of Figures

Figure 1: 1A. The Grande Island, Goa, India (Source: https://mapcarta.com/14887360/Map);	
1B. Bathymetry of the Grande Island (Source: CSIR- NIO, Goa)	10
Figure 2: Transects for underwater survey of Corals and associated fauna	11
Figure 3: Underwater Line Intercept Transect (LIT) survey of Grande Island	12
Figure 4: The Autonomous Reef Monitoring System (ARMS) fabrication and assembly. a) Bottom plate; b) Assembled ARMS; c & d) Top and Side view of ARMS; (Measurements are in mm).....	13
Figure 5: The Grande Island with ARMS Deployment Sites	13
Figure 6: Images of the ARMS deployed in the Grande island coral reef environment	14
Figure 7: Relative abundance of categories, Corals LC- Live Coral; DCA- Dead Coral with algae; Algae TA- Turf Algae; CA- Coralline Algae; MA- Macroalage; AA- Algal assemblage; Sponge SP- Sponge; Other Associates; ZO- Zoanthids; OT- Other Associates; Abiotic S- Sand; R- Rubbles; SI- Silt; RCK- Rock; WA- Water	16
Figure 8: Maps representing the percentage of Bio-Parameters, a) Macro Algae, b) Dead Corals and c) Live Corals, recorded during LIT survey.....	17
Figure 9: Underwater Survey; a) Underwater Photographs of the fauna; b and e) Transect for the survey; c) sample collections for the voucher and molecular taxonomy; d) ARMS deployment during the survey.....	18
Figure 10: Principal component analysis based on the bio-physical components recorded among 9 sites of the Grande Island.....	19
Figure 11: Q Score or Phred Score Plot for the sequences generated cumulative.....	42
Figure 12: Alpha Rarefaction (OTUs observed vs. Sequencing Depth).....	42
Figure 13: Taxonomy Bar plot- Phylum Level.....	43
Figure 14: Cladogram showing OTUs (COI gene) with their phylogenetic relationship, taxonomic assignment of the sampling sites.....	44
Figure 15: Overview of the work accomplished.....	45

Team Members

S No	Member	Designation
1	Dr Dineshram R	Senior Scientist, BOD, CSIR- NIO, Goa
2	Dr Manikandan B	Senior Scientist, BOD, CSIR- NIO, Goa
3	Mr Pramod Kumar Maurya	Principal Scientist, MID, CSIR- NIO, Goa
4	Dr Marimuthu N	Scientist E, ZSI, Kolkata
5	Mr Bharath Subramanyam A	Project Associate, BOD, CSIR- NIO, Goa
6	Ms Vishwa Kale	Dissertation Student, BOD, CSIR- NIO, Goa
7	Mr Anil Kumar Behera	Project Associate, BOD, CSIR- NIO, Goa
8	Ms Farhana N M	Project Associate, BOD, CSIR- NIO, Goa
9	Mr Pranay S Sawant	Project Associate, BOD, CSIR- NIO, Goa
10	Mr Tushar R Lad	Project Associate, BOD, CSIR- NIO, Goa
11	Mr Venkatesh Charloo	NGO, Coastal Impact, Goa
12	Mr Jeremiah Josh	NGO Coastal Impact, Goa

Summary

Coral reefs are considered as most diverse marine ecosystems and also endangered environment. In general, patchy reefs are understudied and one such patchy reef is the Grande Island reef. In the present study, the biological communities associated with corals were studied using a combination of conventional and molecular methods. Line Intercept Transect (LIT) method was used to estimate the relative percent cover of different benthic forms in nine sites that are evenly distributed along the Grande Island. The Coral rich sites were, Lobster Avenue and navy Jetty and same sites were recorded for dead corals rich sites. And macroalgae presence was rich in Roanna's nursery followed by coral garden. The other biophysical parameters were also recorded using LIT survey methodology to provide an insight to the structure of reef environments. The samples were also collected for complementing conventional taxonomy with the molecular taxonomy using COI gene fragment. This study also provided non-invasive biodiversity monitoring alongside with LIT survey using water samples, generating information for a short fragment of COI gene for three different sites, Lobster Avenue, Dog Fish Alley and Coral Garden. All the samples collected and processed for data generation were deposited as voucher specimens. During the study period, artificial structures such as Autonomous Reef Monitoring Structures (ARMS) were deployed in six different sites around the island for collecting information on cryptic biodiversity. This study provided baseline data for the coral habitats of the Grande Island, Goa, which otherwise considered as an understudied reef environment in India. This data would help us in identifying the knowledge gaps and conserve with effective management strategies.

1. Introduction

Coral reefs refer to one of the most diverse of all marine ecosystems as it is a diverse assortment of species which are interrelated to each other (Knowlton & Jackson, 2001; Reaka, 1997). Coral reefs, includes roughly 25% of marine eukaryotic and prokaryotic species in no more than one percent of the ocean surface area (Mies et al., 2020). Coral reefs are also among the most endangered environments on the globe because they are extremely vulnerable to regional effects like sedimentation and pollution as well as global effects like ocean acidification and warming (Ransome et al., 2017). In general, patchy reefs are understudied unlike the major reef environments in India like Lakshadweep archipelago, Gulf of Kachchh, Gulf of Mannar and Palk Bay, Andaman and Nicobar Islands. The Grande Island also known to host a patchy reef is understudied (Manikandan et al., 2016).

In the present study, underwater survey was carried out using line intercept transect (LIT) to study and provide a latest comprehensive baseline of coral diversity of the Grande Island and also to provide the information on other reef communities using video transect and census. By expanding research beyond the few taxa that are visible and well identified taxonomically, DNA barcoding has the potential to considerably advance the comprehension of coral reef diversity in general (Leray & Knowlton, 2016). For accurate species identification a comprehensive molecular database is required (Meyer & Paulay, 2005). And this is achieved by a tool DNA barcoding. In this study, in addition to the underwater survey, samples were collected for voucher specification along with molecular taxonomy identification. DNA barcoding has established as a valuable methodology for the taxonomy. But alongside the voucher specimens provides the verification from which the identification of the species was carried out (Huber, 1998). In the present study, this holds the reason to collect and secure the sample collected as voucher specimen. In the present study, the ARMS structures were deployed underwater near the reef environment of Grande Island in the 6 different locations for long term reef monitoring and will be retrieved after one year from deployment. In addition, the ambient water samples were collected to study the biodiversity of a reef site using eDNA metabarcoding approaches.

Among the biodiversity of coral reefs, cryptic diversity is commonly characterized as the occurrence of multiple evolutionary lineages within the same species that are otherwise morphologically identical (Beheregaray & Caccone, 2007). Cryptic species is the worst-case situation of taxonomic incompleteness. They are identified and demarcated leading to un-

identification and therefore not accessed for conservation efforts. This also makes harder to hypothesize the role and how potentially they are linked to coral reef health. Autonomous Reef Monitoring Structures (ARMS) an artificial structure that use standardized material and its framework will allow the acquired samples to be compared across different spatial scales which gives an ideal opportunity to analyses small organisms within the coral reef habitats in a non-destructive manner. It is now a valid tool having ability to describe eukaryotic faunal biodiversity associated with the coral reefs which proven by several studies (Carvalho et al., 2019; Nichols et al., 2021; Palomino-Alvarez et al., 2021; Ransome et al., 2017).

The organisms in the coral reefs, the DNA may come from excreted cells and tissues (Thomsen & Willerslev, 2015) which is collected as an environmental DNA for the biodiversity monitoring, considered as non-destructive methodology. The difference between DNA barcoding and metabarcoding is generation of identification from one intact specimen or one specimen distinguishable from others and generation of identification from mixtures or fragmented DNA samples up to family level or higher, respectively (Ajmal Ali et al., 2014). The biodiversity assessment was carried out in this study using mitochondrial cytochrome oxidase subunit I (COI) short fragment (Geller et al., 2013; M. Leray et al., 2013) which was used in several studies and concluded on the efficiency of this particular gene fragment for non-invasive sample collection and data processing (Nichols et al., 2021).

In this study, with the help of all different methodology available viz., underwater survey, voucher specimen collection, DNA barcoding and non-invasive water sample collection for the biodiversity assessment, together served to generate a baseline data on the diversity of biological communities of the Grande Island, Goa which is considered to be an understudied reef environment in India. The data generated in this study will help us in identifying the gaps in the conservation and establishing surveillance with effective management strategies.

1.1. Scope of Work

- i.** To assess the coral diversity, abundance using video census and line intercept transect (LIT), based on the morphological features.
- ii.** To expand taxonomic identification by complementing morphology-based identification to the genetic information of the marine fauna.
- iii.** To develop an in-house database for the baseline information collected.
- iv.** To standardize non-invasive Environmental DNA based biodiversity assessment.
- v.** To deploy artificial structures to study hidden cryptic fauna of the Grande island coral reefs for future benthic diversity comparison on a global scale.



2. Methodology

2.1. Study Area

The coastal and marine resources in the Goa islands are abundant and significant from an ecological and livelihood perspective. The Grande Island, situated on the country's central west coast and which is nearby to the mouth of Zuari estuary, off Vasco Da Gama in South Goa, is the primary coastal island of Goa. In this study, The Grande Island was chosen to study the biodiversity, because it is considered an understudied coral reef according to Manikandan et al., 2016. In total 10 sites were assessed for biodiversity by underwater survey. And artificial structures were deployed during the survey and also based on the previous studies (Manikandan et al., 2016; Patankar et al., 2018). In general, Coral reefs safeguard the coastal environment and harbor diverse lifeforms. The role of patchy reefs is still unaddressed that always considered as a hotspot for tourism and harboring fish life.



Figure 1: 1A. The Grande Island, Goa, India (Source: <https://mapcarta.com/14887360/Map>); 1B. Bathymetry of the Grande Island (Source: CSIR- NIO, Goa)

2.2. Underwater Survey- LIT Method

The Grande Island's coral habitats were surveyed using Line Intercept Transect (LIT) with the transects made parallel to the shore line, and up to 5 meters depth from the shore. Each transect length was 20 meters and was laid in triplicates at all the study sites during the survey. Each transect was separated by 5 meters in length and laid in parallel to the shore line (**Figure 2**). In total 9 sites around the island (**Figure 3; Table 1**) were surveyed using LIT method to estimate the coral presence and diversity along with other life-forms associated with corals, for example, sponges, macroalgae, coralline and turf algae and Zoanthids. Along with life-forms associates, abiotic factors of the sites were also measured, for example, rocks, silt, sand, rubbles and water. The coral communities were categorized into live corals and macroalgae. The sites along with the entire biodiversity recorded was categorized by North and South of the Grande Island. Along with the survey, photographs were taken for the identification and also for the category, other associates. The flora and fauna of Grande Island was noted using underwater images into Corals, Fish, Macroalgae and other fauna (Mollusca, Sea Urchin, Sea Cucumber, etc.,).

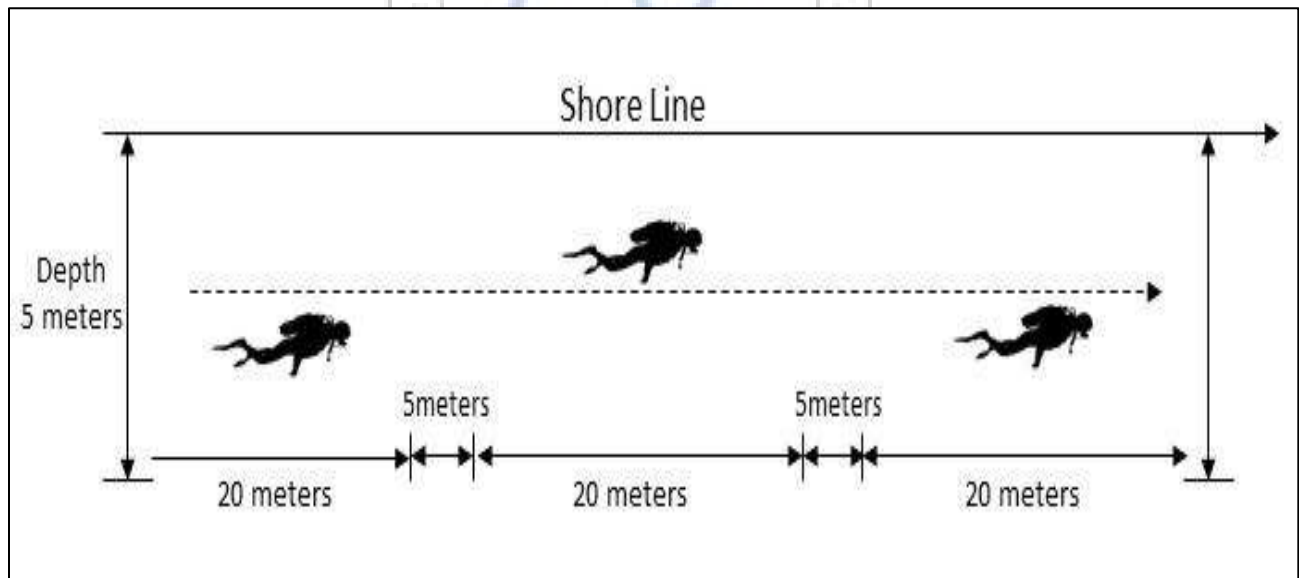

Figure 2: Transects for underwater survey of Corals and associated fauna

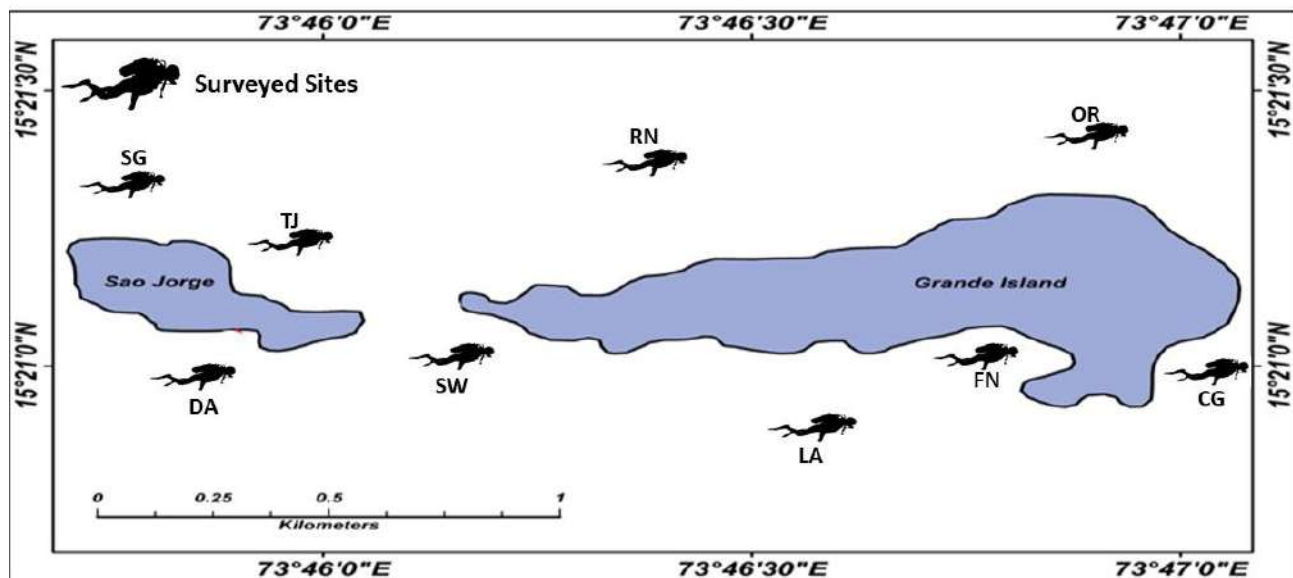

Figure 3: Underwater Line Intercept Transect (LIT) survey of Grande Island

Table 1: Underwater Survey sites with coordinates and date

S. No	Site Name (Code)	Coordinates		Survey Date
		N	E	
1	Coral Garden (CG)	15° 21' 1.4"	73° 46' 59.84"	25.01.2023
2	Dogfish Alley (DA)	15°20'56.6"	73°45'53.5"	26.01.2023
3	Lobster Avenue (LA)	15°21'00.1"	73°46'32.6"	26.01.2023
4	Roanna's Nursery (RN)	15°21'19.6"	73°46'19.9"	27.01.2023
5	Navy Jetty (TJ)	15°21'08.8"	73°45'58.3"	27.01.2023
6	Sting Ray City (SW)	15°21'05.1"	73°46'08.5"	28.01.2023
7	North-East of St. George Island (SG)	15°21'16.0"	73°45'52.6"	28.01.2023
8	Freddy's Nook (FN)	15°21'00.4"	73°46'49.9"	29.01.2023
9	On the Rocks (OR)	15°21'25.0"	73°46'42.7"	29.01.2023

2.3. ARMS Deployment

Six ARMS units were installed at five different sites at a depth via SCUBA. Each ARMS unit consists of a base plate of 35 x 45 cm and a stack of 22.5 x 22.5 cm PVC plates and spacers stacked

alternately in open and closed configurations with the measurements provided in **Figure 4**. The bars are placed alternatively to create different flow regimes.

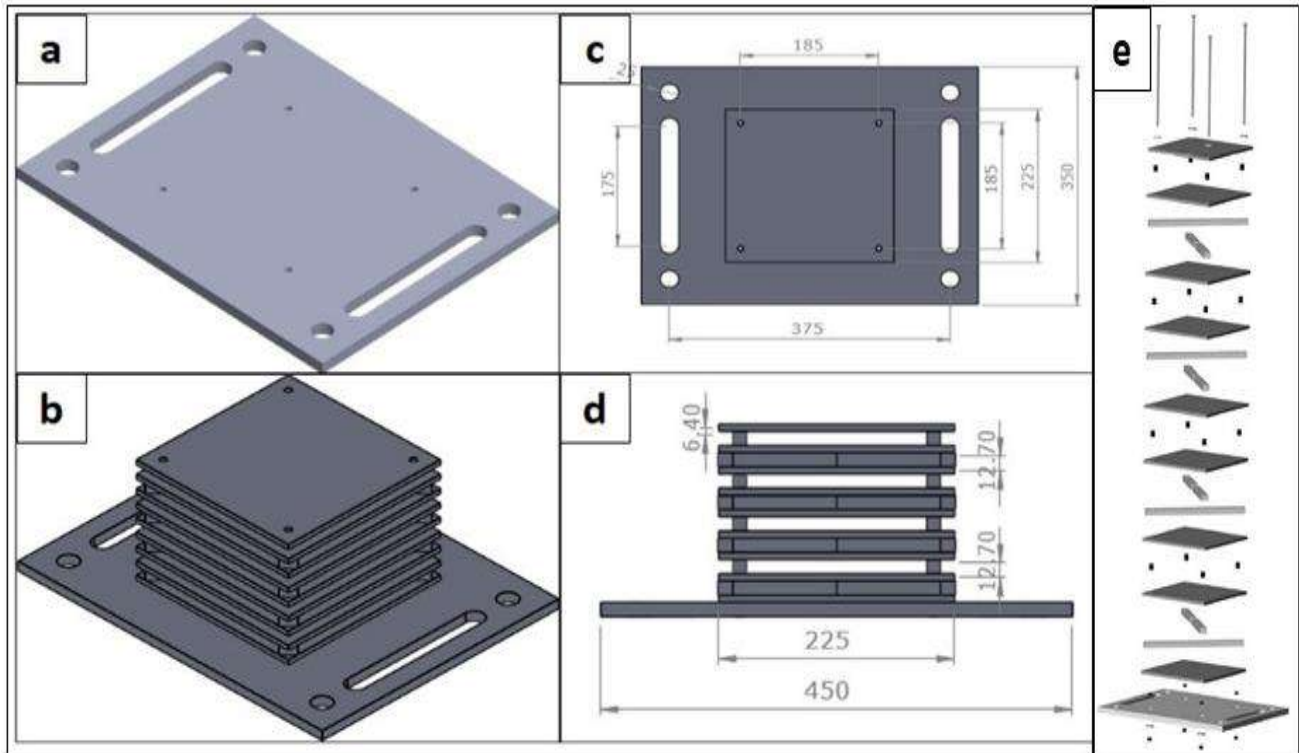

Figure 4: The Autonomous Reef Monitoring System (ARMS) fabrication and assembly. a) Bottom plate; b) Assembled ARMS; c & d) Top and Side view of ARMS; (Measurements are in mm)

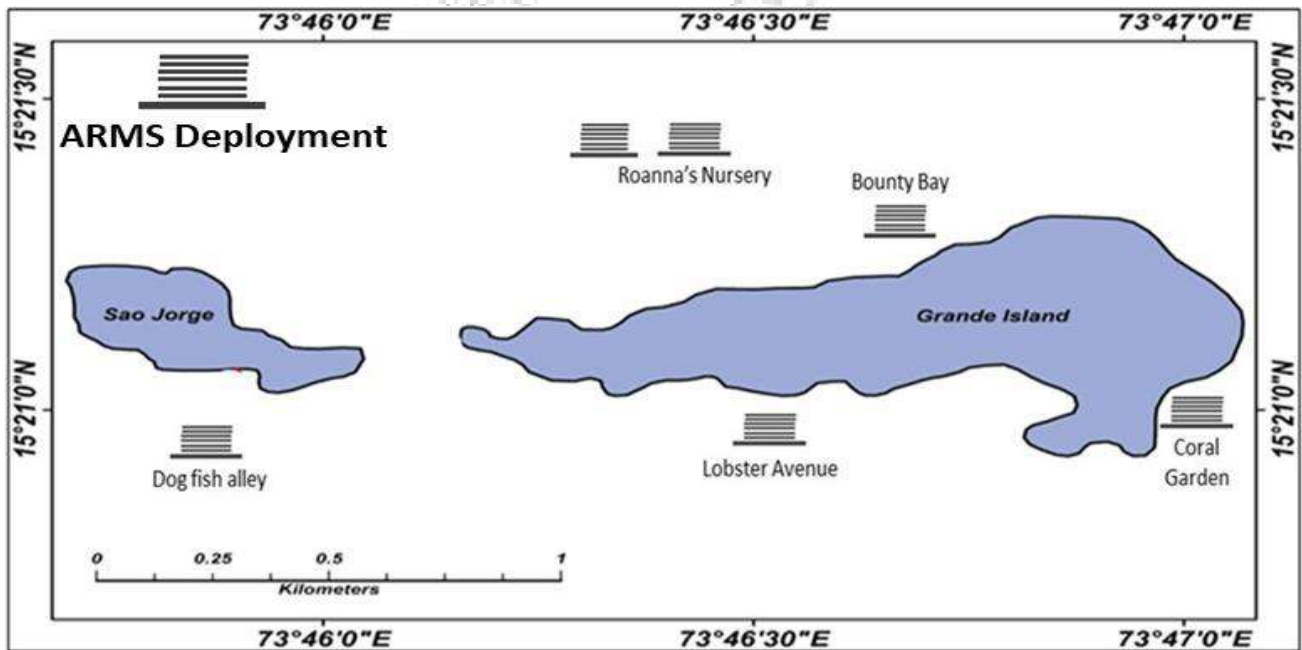

Figure 5: The Grande Island with ARMS Deployment Sites

The deployment was carried out by nailing the bottom plate of the ARMS to the rocks or bed using the nails for all four sides of the ARMS for stability during the period underwater (8-12 months). The deployment was carried out with the help of SCUBA-certified personnel. The deployment was carried out based on the data available from available studies (Manikandan et al., 2016; Patankar et al., 2018). Each site of ARMS deployment was marked for the coordinates using a GPS and the buoy was tied to the ARMS for retrieval after 8-12 months from the deployment (Figure 5 and Figure 6; Table 2).

Table 2: Autonomous Reef Monitoring System (ARMS) deployment

S. No	Site Name	Coordinates		No. ARMS Deployed	Deployed Date
		N	E		
1	Coral Garden	15° 21' 1.4"	73° 46' 59.84"	1	17.12.2022
2	Dogfish Alley	15°20'56.6"	73°45'53.5"	1	26.01.2023
3	Lobster Avenue	15°21'00.1"	73°46'32.6"	1	18.12.2022
4	Roanna's Nursery	15°21'19.6"	73°46'19.9"	2	27.01.2023
5	Bounty Bay	15°21'18.036"	73°46'44.22"	1	17.12.2022



Figure 6: Images of the ARMS deployed in the Grande island coral reef environment

2.4. Taxonomic Identification

During the underwater survey, marine faunal samples were collected for taxonomic identification (**Table 4; Table 6**). Later, a part of the sample was used for molecular taxonomy (DNA). The DNA isolated was amplified and sequenced for Cytochrome Oxidase Subunit I Gene with approx. length of 700bp using Sanger Sequencing or the dideoxy chain-termination sequencing method. The sequences were processed using Codon Code Aligner (version) for the contig and carried out nucleotide BLAST to identify the Genus/Species level. The sequence was later deposited in the NCBI nucleotide database and obtained accession number.

2.5. Non-Invasive Biodiversity Monitoring

In addition to the underwater survey and sample collection for voucher specification, the water was collected as a non-invasive sampling to assess the biodiversity on the site. The water samples were collected close to the ARMS structure deployment and filtered using a 0.2µm polyether sulfone filter. The filter was processed for DNA isolation. Further, the DNA isolated was used for the biodiversity assessment by amplifying and sequencing a gene fragment, Cytochrome Oxidase Subunit I of an approximate length of 350bp (Geller et al., 2013; Matthieu Leray et al., 2013).

The Sequencing was carried out using, Illumina MiSeq 500cycles. Before the sequencing, the samples were assessed for quality and prepared for sequencing. In other words, the library preparation was carried out for the samples using the NEB Next Ultra DNA Library preparation kit. The sequencing results were processed using **Qiime2 (version: qiime2-2025.5)**. The sequences obtained were first de-multiplexed and imported into the qiime2 pipeline. The imported artifact was first processed for denoising and chimera removal using **dada2** program within qiime2. And the denoised sequences were clustered using **vsearch** with 97% similarity. The clustered sequences were processed for the alpha rarefaction curve (OTUs vs. Sequencing depth) to confirm the sequencing depth sufficient to assess the biodiversity within the sample collected. The clustered sequences were also processed for the phylogenetic tree (rooted and un-rooted), followed by other core-metrics analyses. Later, the clustered sequences were assigned for the taxonomy using the pre-formatted DNA database for the COI available, **MIDORI2 (GB255 qiime2 version)**. The taxonomy assigned was then filtered for non-targeted taxa using the filter-taxa function within the qiime2. For the visualization, both a bar chart was provided. The heatmap was also generated using the taxa assigned to visualize the comparative abundance among the

samples. Also relating the phylogeny from the OTUs generated to the taxonomic assignments and with the sample specific, was generated using **Empress Plugin v1.2.0**.

3. Results

3.1. Line Intercept Transect (LIT) Survey

From the LIT survey, overall biodiversity varied site to site considering recorded biophysical categories which was given in **Figure 7**. The corals presence is rich in the sites, The Navy Jetty and Lobster Avenue followed by On the Rocks and Coral Garden. Comparatively less corals were seen in the site North-East St George Island.

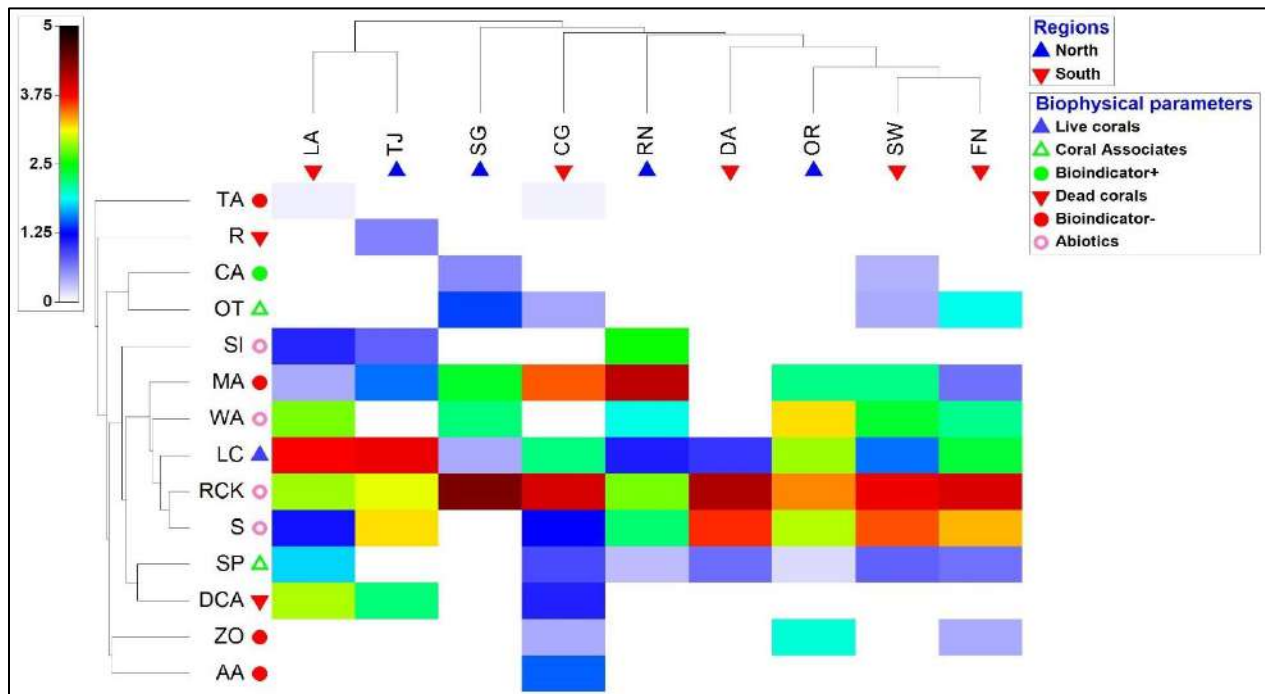

Figure 7: Relative abundance of categories, **Corals** LC- Live Coral; DCA- Dead Coral with algae; **Algae** TA- Turf Algae; CA- Coralline Algae; MA- Macroalage; AA- Algal assemblage; **Sponge** SP- Sponge; **Other Associates** ZO- Zoanths; OT- Other Associates; **Abiotic** S- Sand; R- Rubbles; SI- Silt; RCK- Rock; WA- Water

From the data collected on the biophysical parameters from the underwater survey using Line Intercept Transect (LIT) method, two regions were recorded to have high coral presence (Live Coral; LA), Navy Jetty (TJ) and Lobster Avenue (LA). Interestingly, same sites were recorded to have more dead corals. Similarly, the biophysical parameter which holds influence on corals

growth according to several studies is Macroalgae (MA). The sites recorded with low live coral presence were also observed to have high macroalgae, Roanna's Nursery (RN) and Coral Garden (CG) (**Table 3; Figure 8**). From the data, it is clear the distribution of corals (Live and Dead), Macroalgae and other algal assemblages observed were not correlated to any spatial variations. The coral rich sites were one on the north of the Island (TJ) and one on the south (LA).

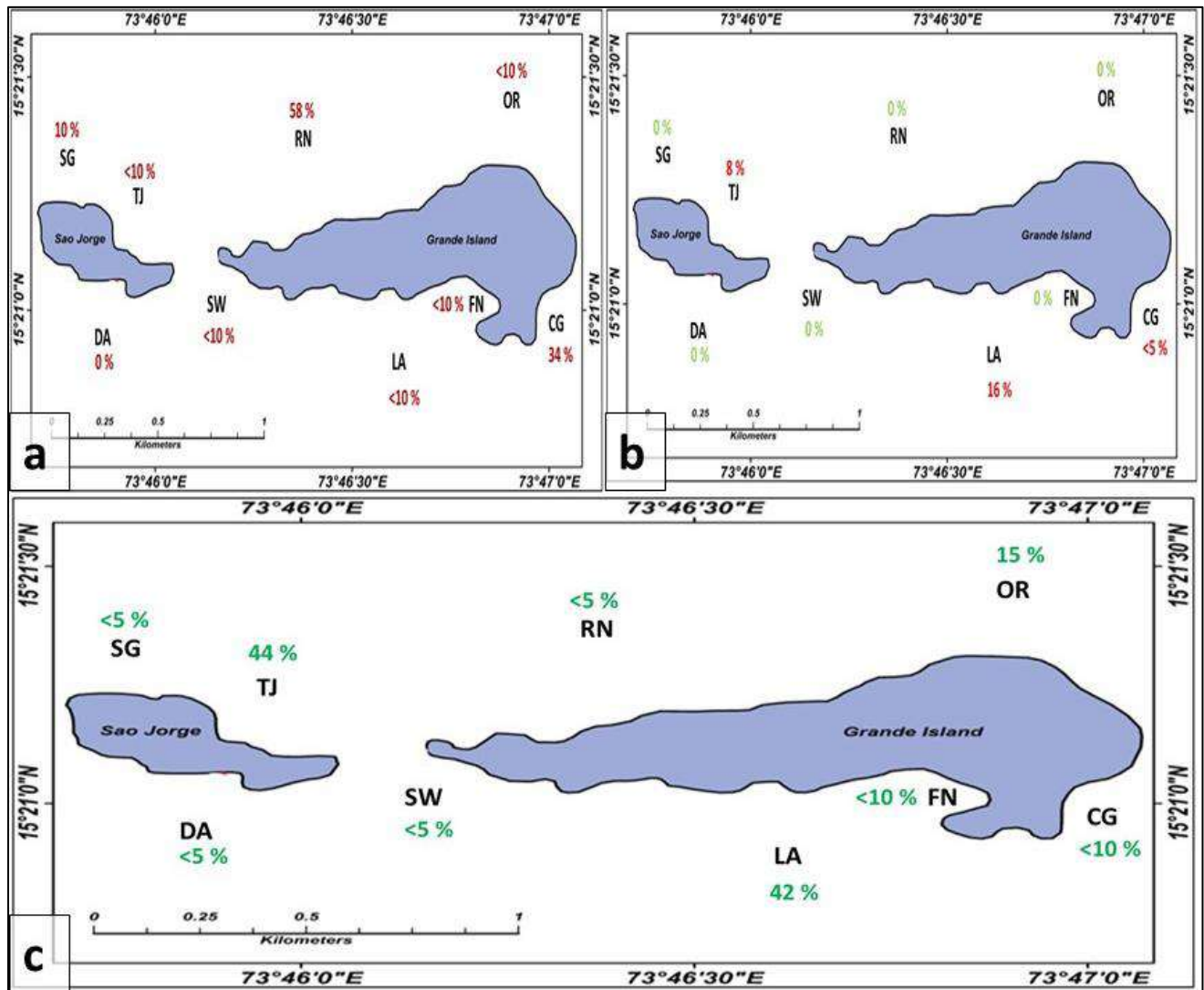

Figure 8: Maps representing the percentage of Bio-Parameters, a) Macro Algae, b) Dead Corals and c) Live Corals, recorded during LIT survey

Table 3: Average percent cover of Live Corals, Dead Corals and Macro Algae of the Grande Island

Live Corals (LC)	% mean cover within a site (Approx.)	44	42	15	9	8	Less than 5 %
	Sites	Navy Jetty (TJ)	Lobster Avenue (LA)	On the Rocks (OR)	Freddy' s Nook (FN)	Coral Garden (CG)	All other Sites
Macro algae (MA)	% mean cover within a site (Approx.)	58		34	10		Less than 10 %
	Sites	Roanna' s Nursery (RN)		Coral Garden (CG)	North East of St George Island (SG)		All other Sites
Dead Coral with Algae (DCA)	% mean cover within a site (Approx.)	16		8		Less than 5 %	
	Sites	Lobster Avenue (LA)		Navy Jetty (NJ)		Coral Garden (CG)	

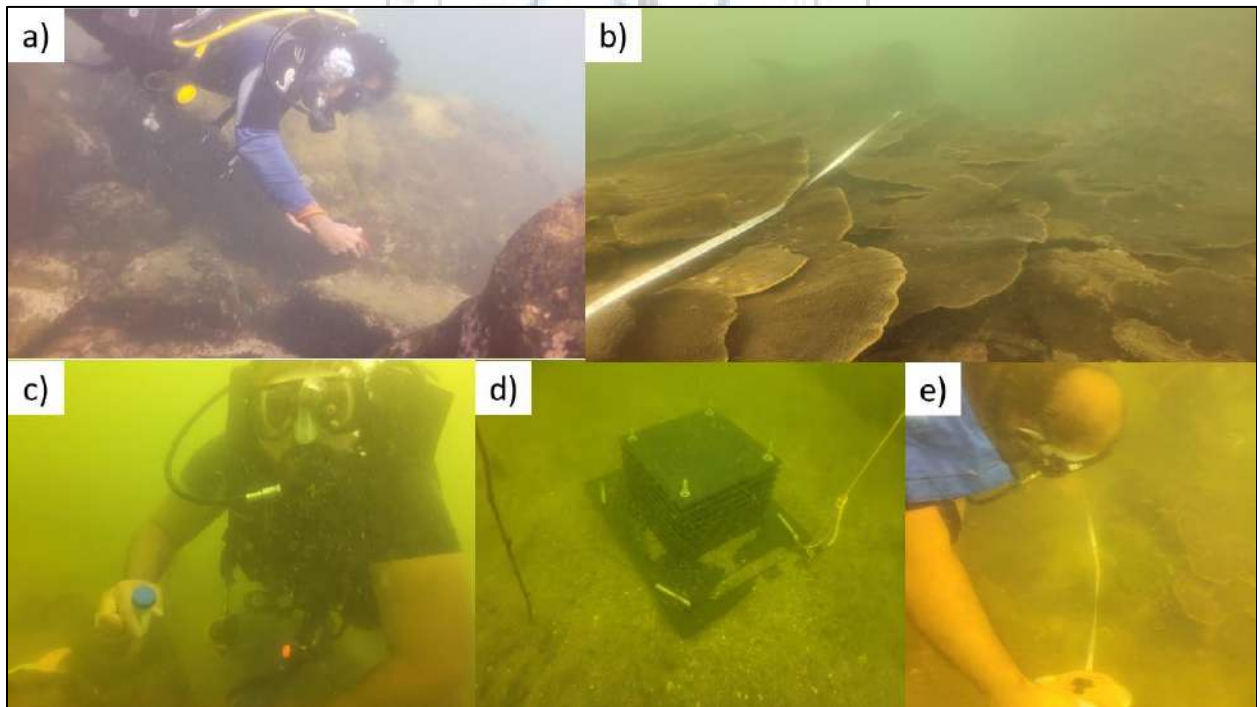

Figure 9: Underwater Survey; a) Underwater Photographs of the fauna; b and e) Transect for the survey; c) sample collections for the voucher and molecular taxonomy; d) ARMS deployment during the survey

Based on the biophysical parameters recorded, likely, Corals LC- Live Coral; DCA- Dead Coral with algae; Algae TA- Turf Algae; CA- Coralline Algae; MA- Macroalgae; AA- Algal assemblage; Sponge SP- Sponge; Other Associates ZO- Zoanthids; OT- Other Associates; Abiotic S- Sand; R- Rubbles; SI- Silt; RCK- Rock; WA- Water, Principal component plot was arrived. Based on the Principal component plot and heatmap, sites Navy Jetty and Lobster Avenue was clustered based on Live corals and Dead Corals with algae. Whereas sites, Roanna's nursery and Coral Garden on the macroalgae and other algal assemblages. In total, the similarity was 67.5% based on the principal component analysis on regions parted as north and south of the Grande Island. The sites, Freddys nook, Sting Ray City, On the Rocks, and North-East of St. George Island, of the Grande Island, clustered on the abiotic factors, rocks, sand and biotic factors, other coral associates (Fish, sea urchins, etc.), and Zoanthids (**Figure 10**).

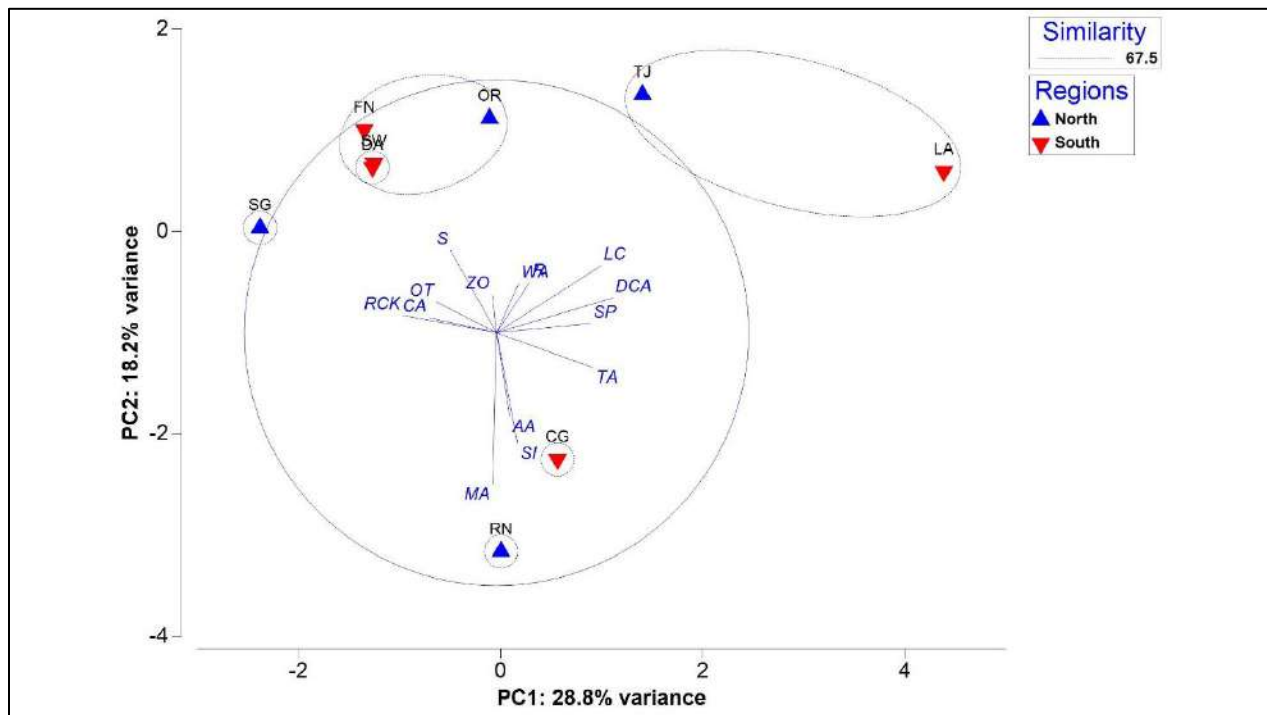

Figure 10: Principal component analysis based on the bio-physical components recorded among 9 sites of the Grande Island.

3.2. Taxonomic Assignment

The samples collected were sorted and labelled for taxonomic identification and voucher specification. The sponge samples collected were processed to isolate the spicules which were

used for the taxonomic identification by Zoological Survey of India, Kolkata, followed by the voucher deposition in ZSI (**Table 4, Table 5**).

Table 4: Details of sponge samples collected, taxonomy identification and voucher specimen

S. No	Date of Sample Collection	Sample Site	Sample NIO Code	Taxonomy (Based on the Spicules isolated)	Voucher Specimen
1	29.01.2023	Freddy's Nook, Grande Island, Goa, India	FN SP 01	<i>Clathria (Microciona) atrasanguinea</i> (Bowerbank, 1862)	ZSI- HQ/GNE/P4607/1
2		On the Rocks, Grande Island, Goa, India	ORK SP 02	<i>Clathria (Thalysias) cervicornis</i> (Thiele, 1903)	ZSI- HQ/GNE/P4608/1
3		On the Rocks, Grande Island, Goa, India	ORK SP 01	<i>Poecillastra eccentrica</i> (Dendy & Burton, 1926)	ZSI- HQ/GNE/P4609/1
4		On the Rocks, Grande Island, Goa, India	ORK WS 01	<i>Chalinula nematifera</i> (de Laubenfels, 1954)	ZSI- HQ/GNE/P4610/1
5		On the Rocks, Grande Island, Goa, India	ORK SP 04	<i>Placospongia carinata</i> (Bowerbank, 1858)	ZSI- HQ/GNE/P4611/1
6		On the Rocks, Grande Island, Goa, India	ORK YS 01	<i>Callyspongia (Cladochalina) spinosissima</i> (Dendy, 1887)	ZSI- HQ/GNE/P4612/1
7		Freddy's Nook, Grande Island, Goa, India	FN SP 02	<i>Cliothosa quadrata</i> (Hancock, 1849)	ZSI- HQ/GNE/P4613/1

Table 5: Sponge sample with their spicules isolated, Species ID and Voucher specification

Species ID: *Callyspongia (Cladochalina) spinosissima* (Dendy, 1887);

Voucher specimen: ZSI-HQ/GNE/P4612/1

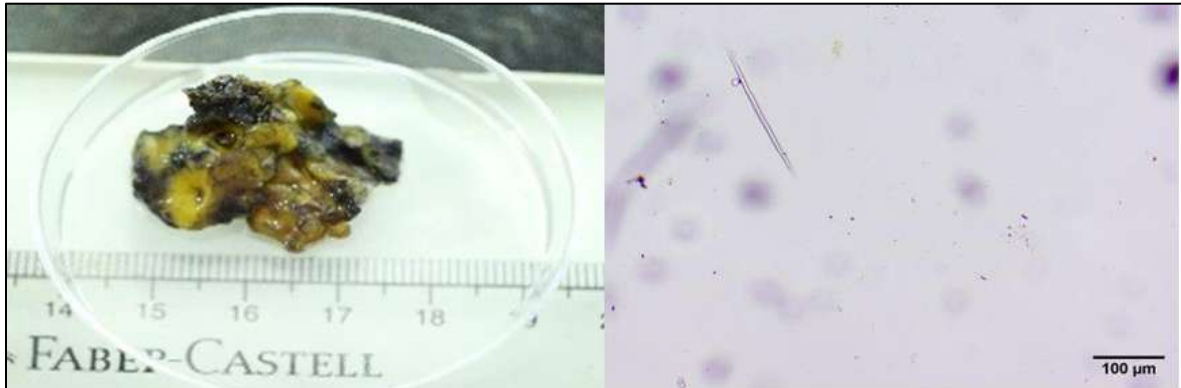

Species ID: *Chalinula nematifera* (de Laubenfels, 1954)

Voucher specimen: ZSI-HQ/GNE/P4610/1

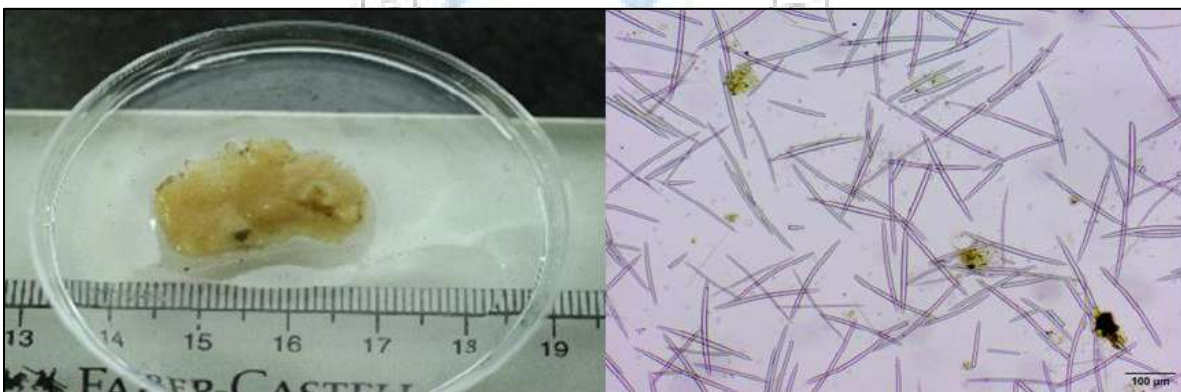

Species ID: *Clathria (Microciona) atrasanguinea* (Bowerbank, 1862)

Voucher specimen: ZSI-HQ/GNE/P4607/1



Species ID: *Cliothosa quadrata* (Hancock, 1849)

Voucher specimen: ZSI-HQ/GNE/P4613/1

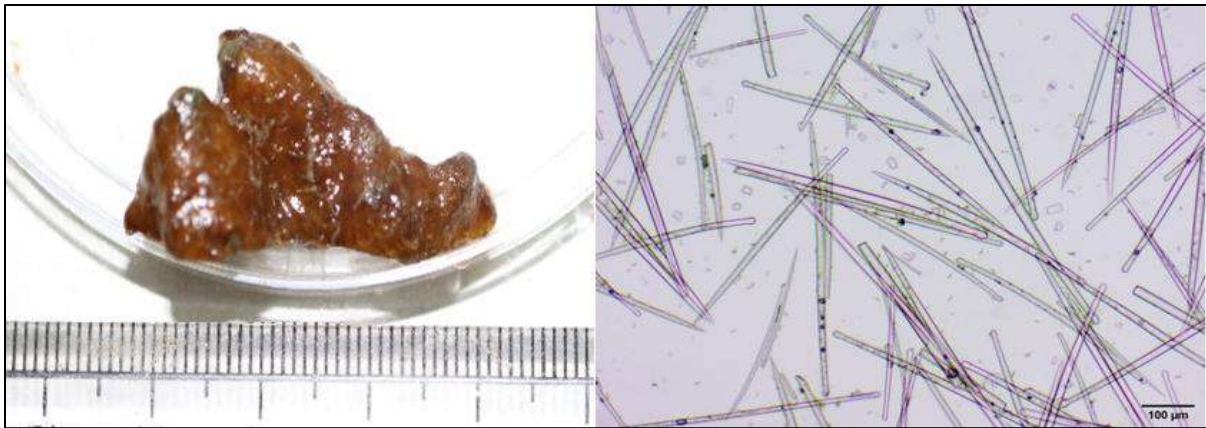

Species ID: *Poecillastra eccentrica* (Dendy & Burton, 1926)

Voucher Specimen: ZSI-HQ/GNE/P4609/1



Species ID: *Clathria (Thalysias) cervicornis* (Thiele, 1903)

Voucher Specimen: ZSI-HQ/GNE/P4608/1



Species ID: *Placospongia carinata* (Bowerbank, 1858)

Voucher Specimen: ZSI-HQ/GNE/P4611/1

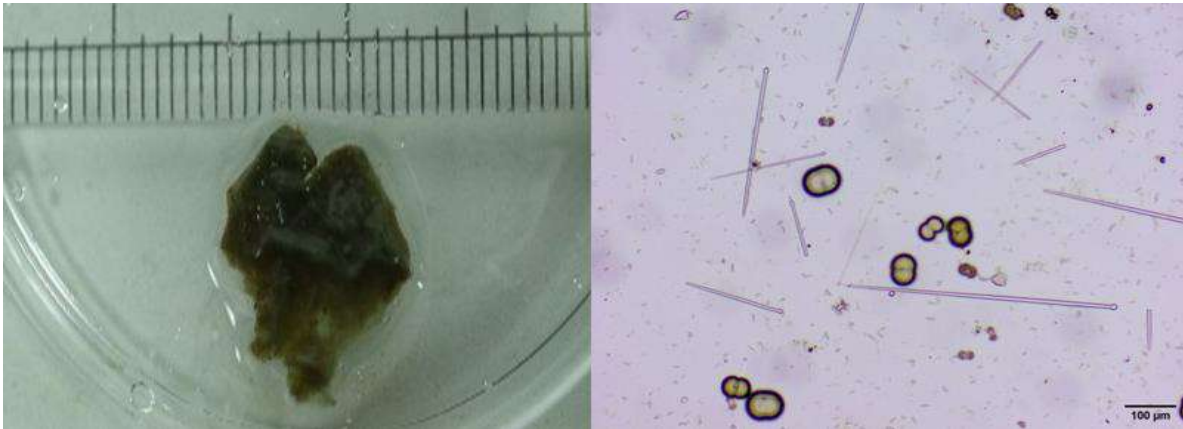

Table 6: Molecular Taxonomy based on the Cytochrome Oxidase Subunit 1 gene

S No	Sample Code	Location	Description	Species ID- NCBI BLAST	NCBI Accession Number
1	S1LA	Rock and Ridge	Coral Nubbin	<i>Turbineria sp.</i>	*
2	ORKS4	On the Rocks	Coral Nubbin	<i>Plesiastrea sp.</i>	*
3	ORKS3	On the Rocks	Coral Nubbin	<i>Coscinarea sp.</i>	*
4	FNCB01	Freddys Nook	Coral Nubbin	<i>Stylararea sp.</i>	*
5	FNSP02	Freddys Nook	Sponge Sample	<i>Sphaciospongia solida</i>	*
6	CA	Lobster Avenue	Conch Animal	<i>Turbinella pyrum</i>	OR186340
7	F1 SRC	Sting Ray City	Fish	<i>Halichoeres nigrescens</i>	OR186341

8	ORKBS04	On the Rocks	Brittle Star	No match in NCBI database is available	-
9	ORKBS02	On the Rocks	Brittle Star		-
10	ORKPC02	On the Rocks	Polychaete		-

*** NCBI GeneBank submission is in progress**

Samples collected during the underwater survey were processed for molecular taxonomy. The DNA obtained from the samples were amplified for the Cytochrome Oxidase subunit I of approx. size 650-700bp and sequenced using dideoxy chain terminating methodology or Sanger sequencing. The sequences generated was then uploaded in the NCBI generated Accession number for the same. And few sequences that are under process to obtain NCBI GenBank Accession number, the BLAST results are provided in a **Table 6**.

The photographs taken during the underwater survey was sorted for the fish, macroalgae, soft corals and identified based on the morphological features to create a baseline biodiversity of Grande island coral reef ecosystem (**Plate 1; Plate 2; Plate 3; Plate 4; Plate 5; Plate 6; Table A 1, Table A 2, Table A 3, Table A4, Table A 5**). Along with the other fauna, coral nubbins (smallest fragment possible) were also collected for the morphological, voucher specimen deposition and few for molecular taxonomy.

Plate 1: Coral nubbins for voucher specimen (Sample code)

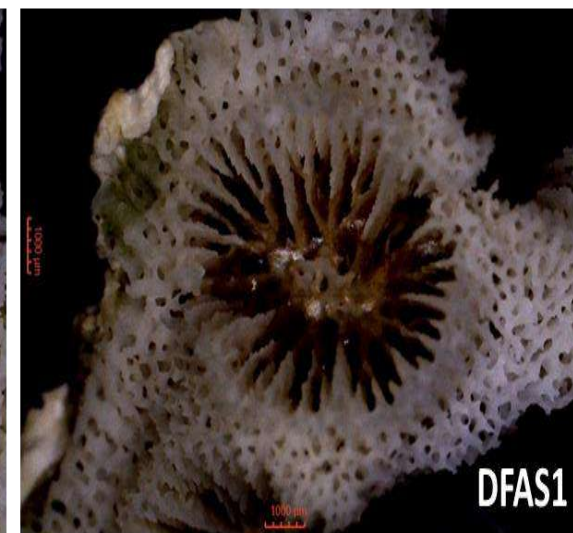
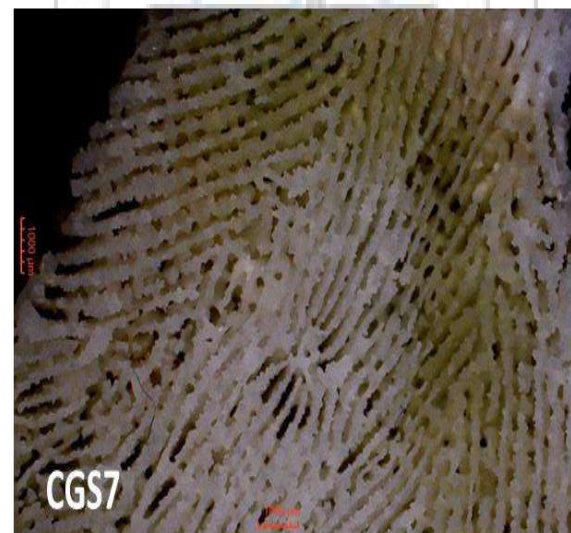
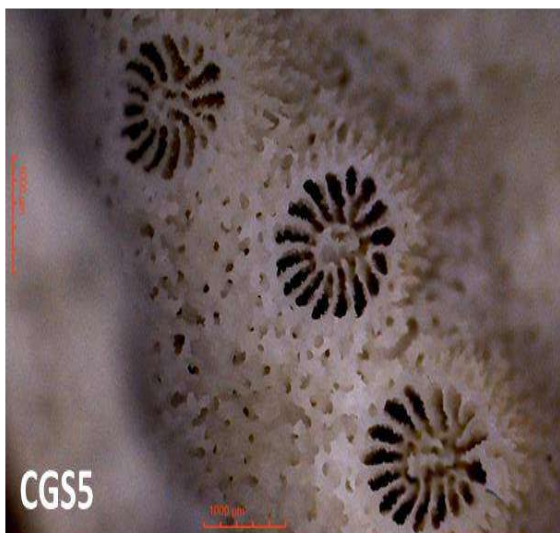
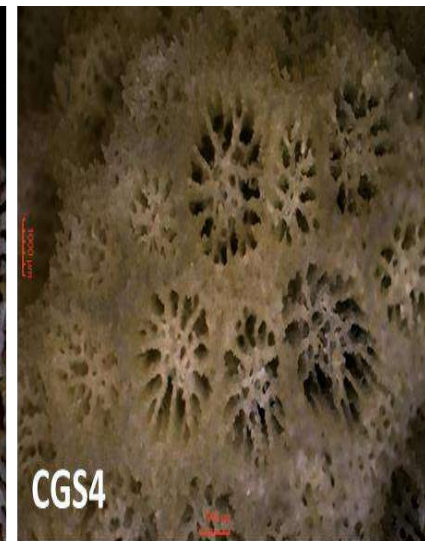
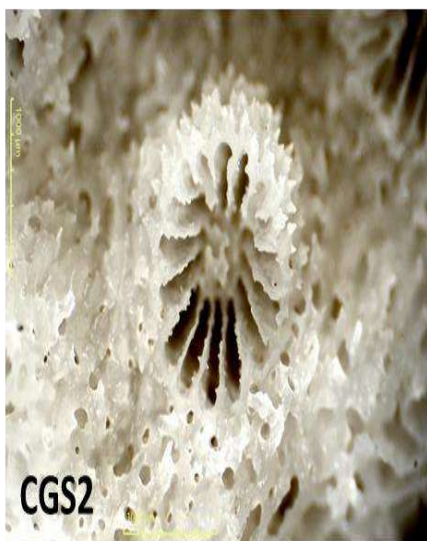

Plate 1 (Continued): Coral nubbins for voucher specimen (Sample code)

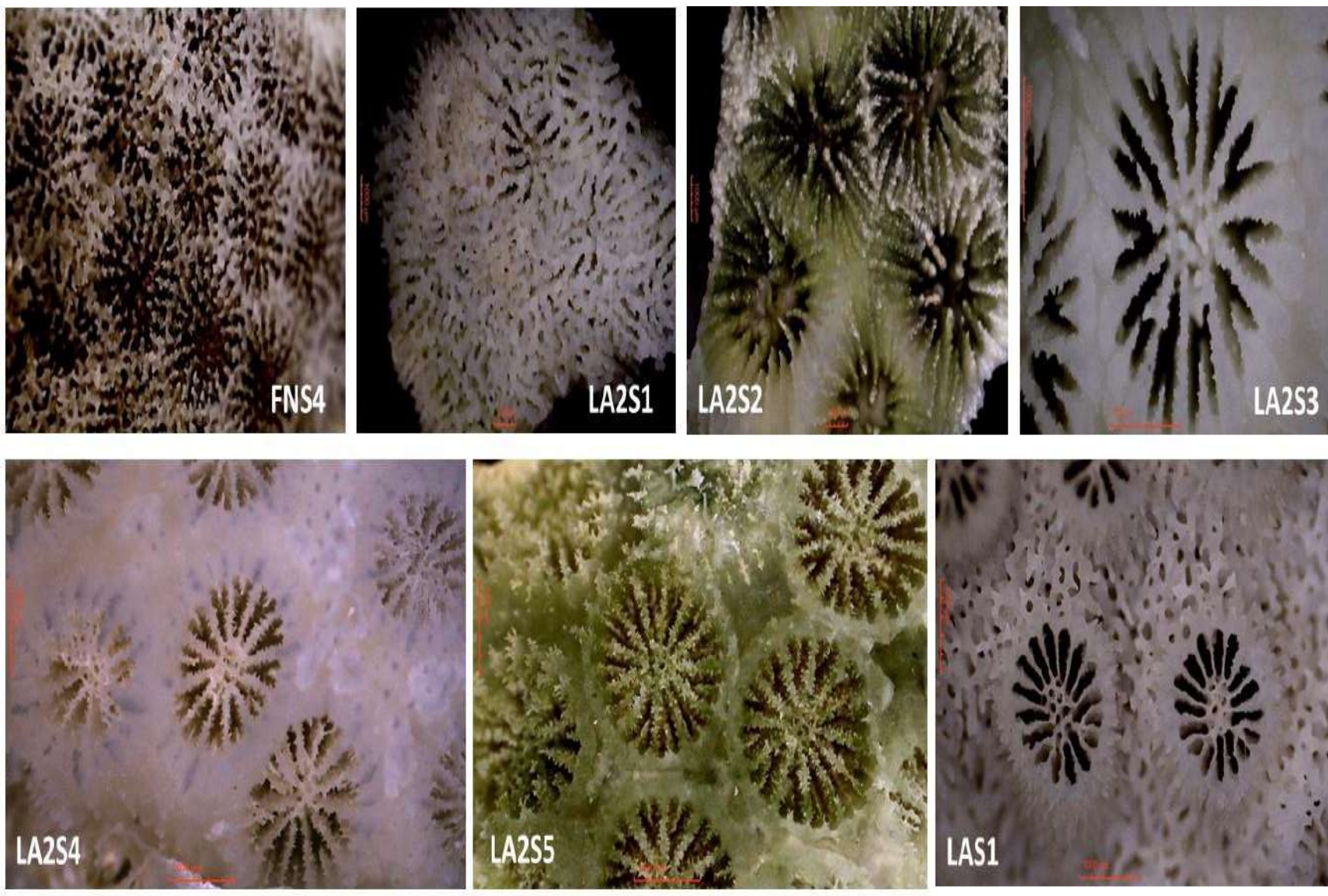

Plate 1 (Continued): Coral nubbins for voucher specimen (Sample code)

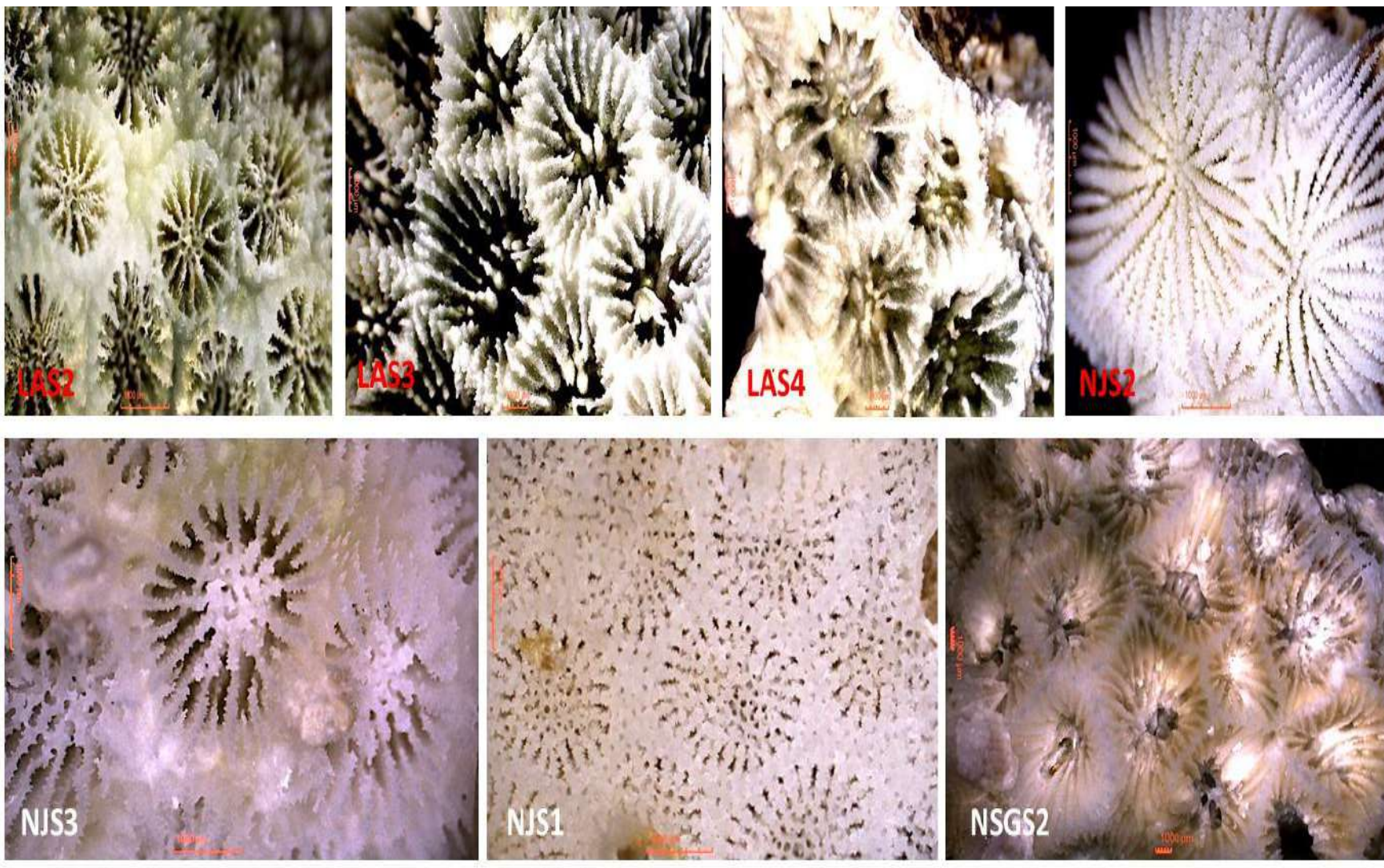

Plate 1 (Continued): Coral nubbins for voucher specimen (Sample code)

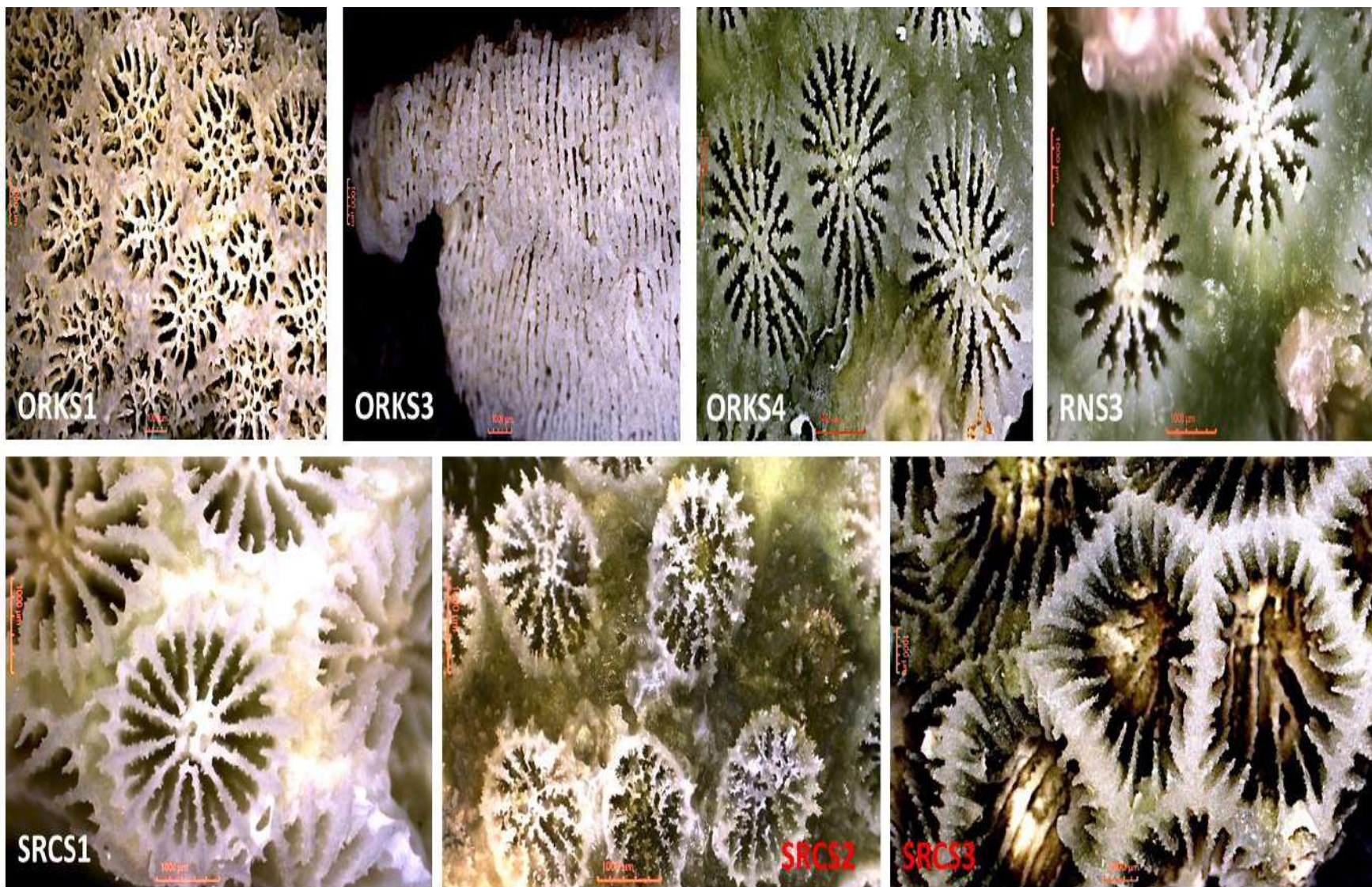

Plate 1 (Continued): Coral nubbins for voucher specimen (Sample code)

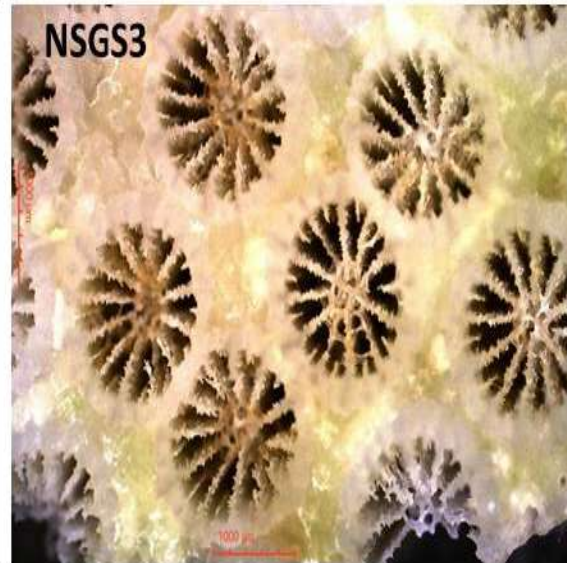
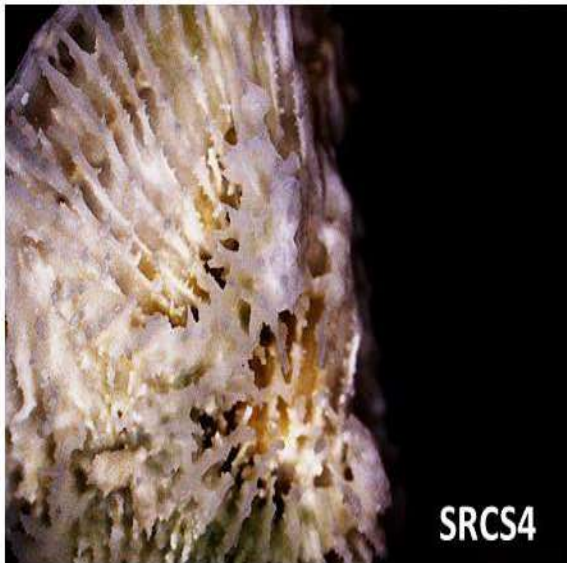
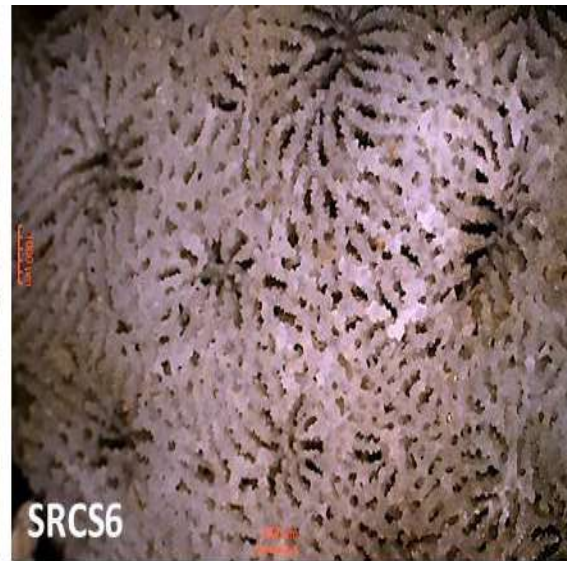

Plate 2: Fishes recorded during the underwater survey, Grande Island

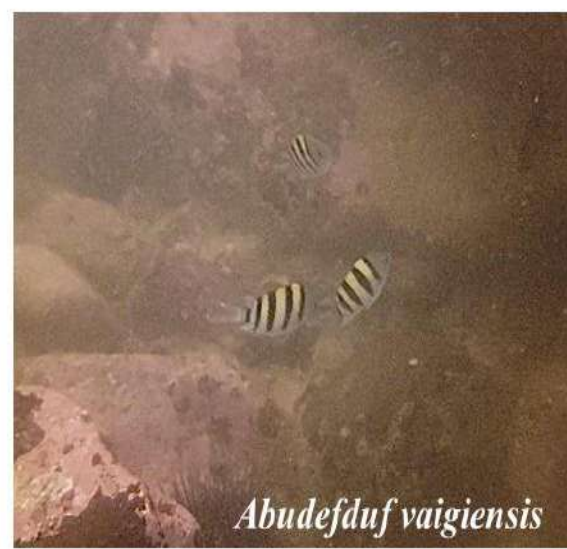
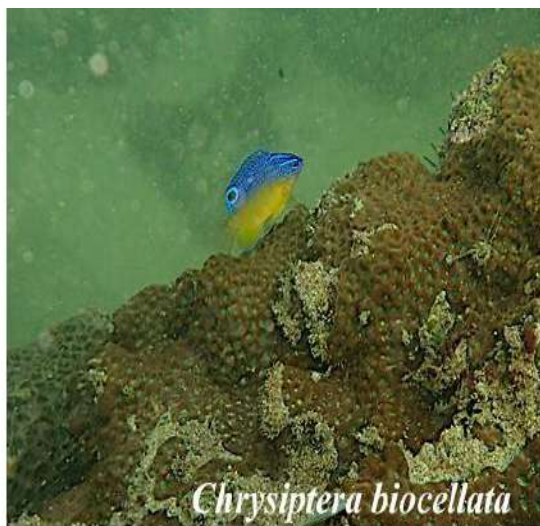
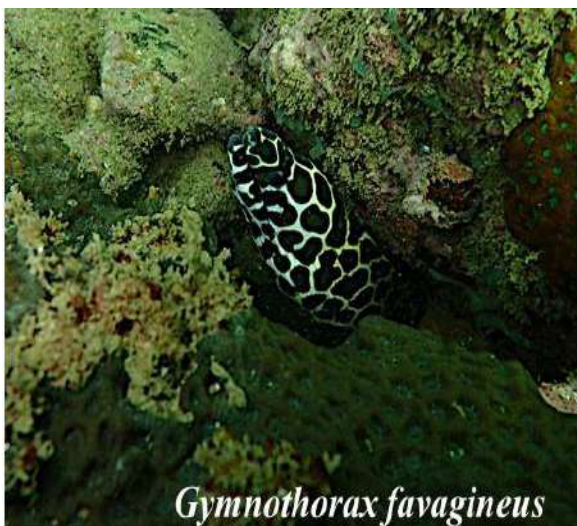

Plate 2 (Continued): Fishes recorded during the underwater survey, Grande Island

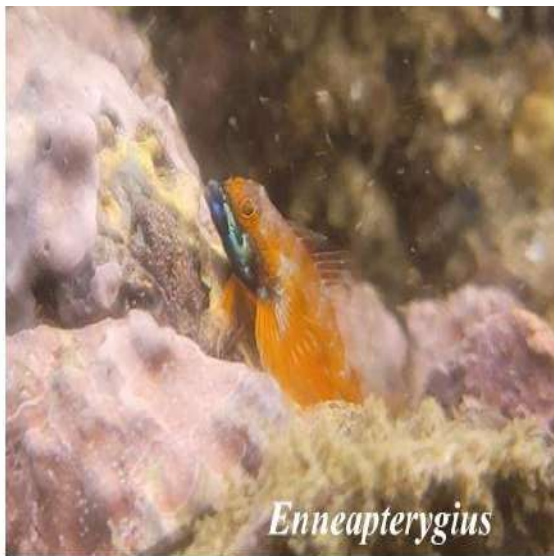

Plate 2 (Continued): Fishes recorded during the underwater survey, Grande Island

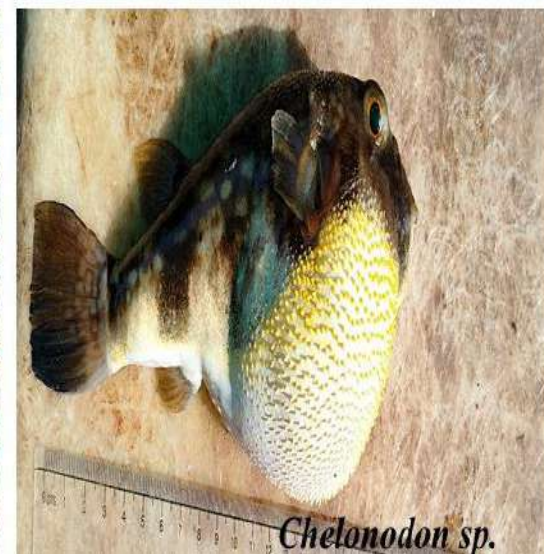

Plate 2 (Continued): Fishes recorded during the underwater survey, Grande Island

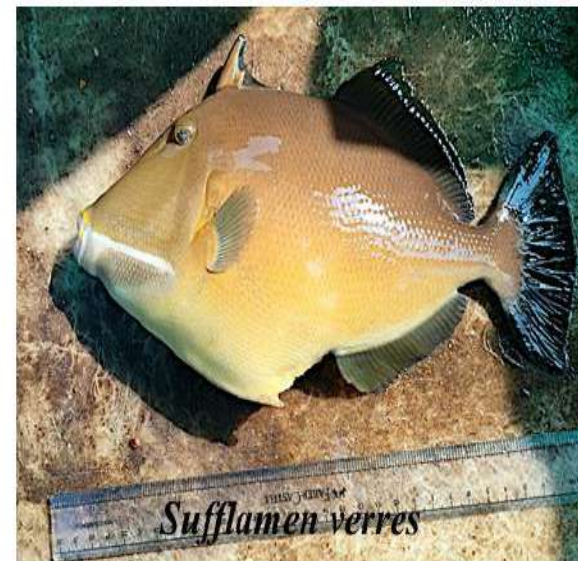
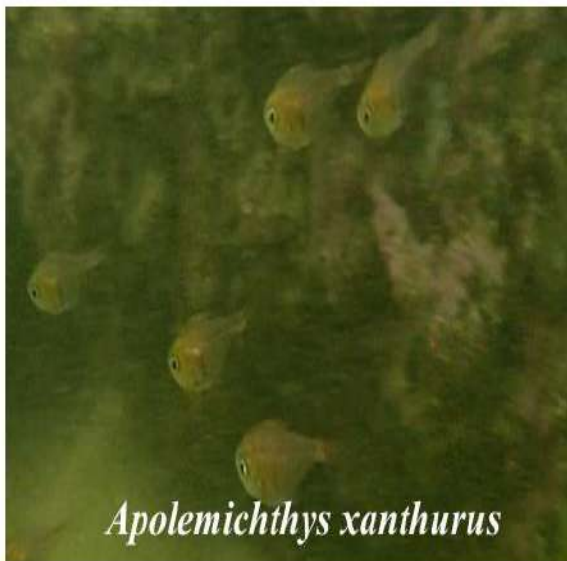

Plate 3: Macroalgae recorded during the underwater survey, Grande Island

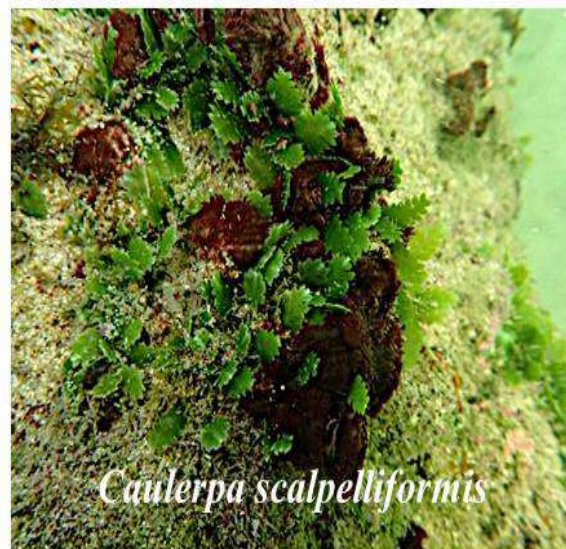
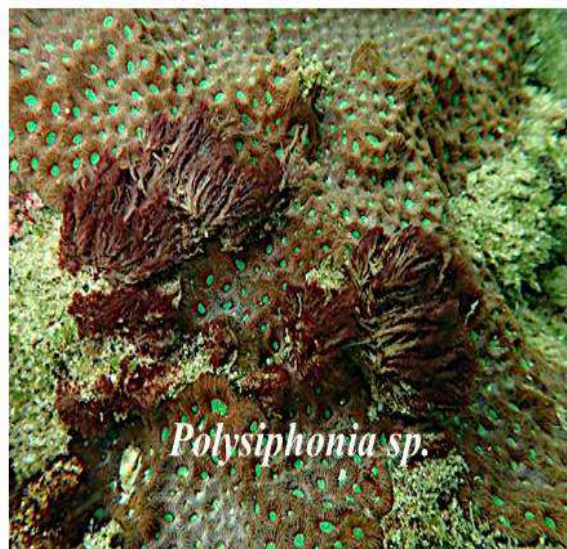
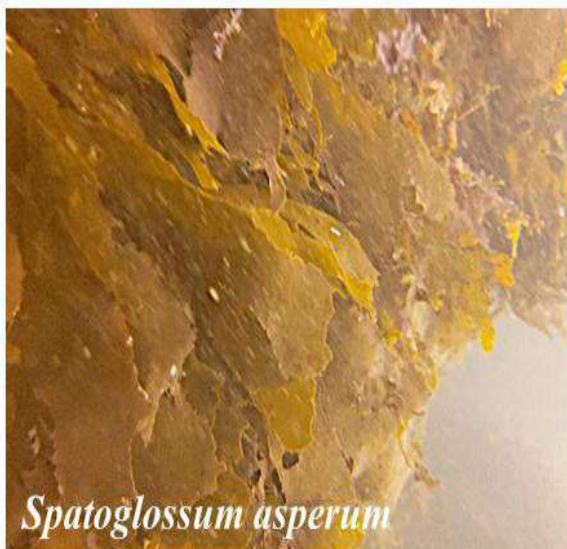
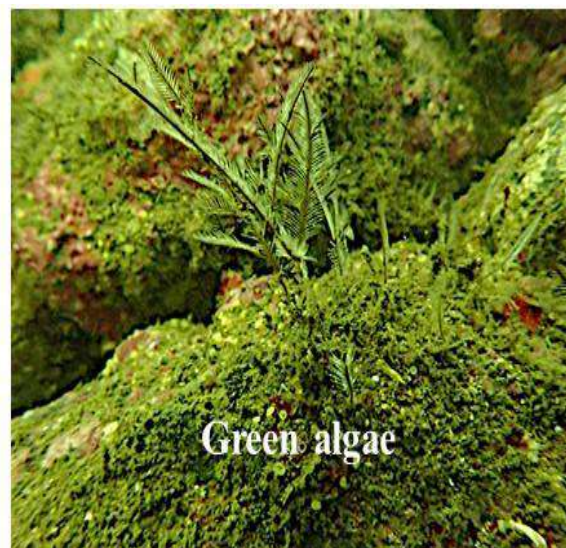
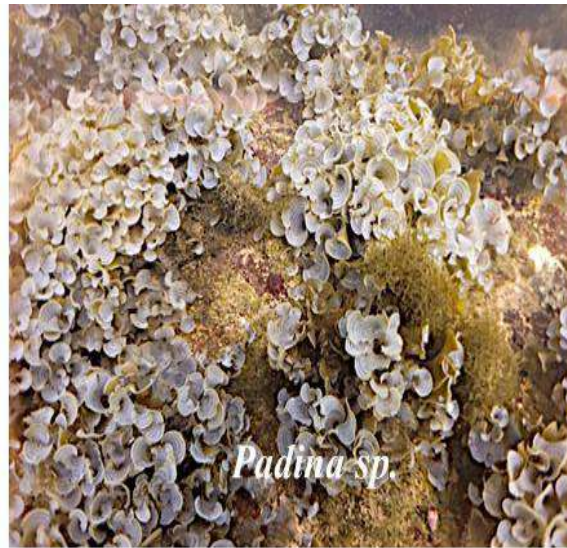

Plate 3 (Continued): Macro algae recorded during the underwater survey, Grande Island



Plate 4: Soft Corals recorded during the underwater survey, Grande Island

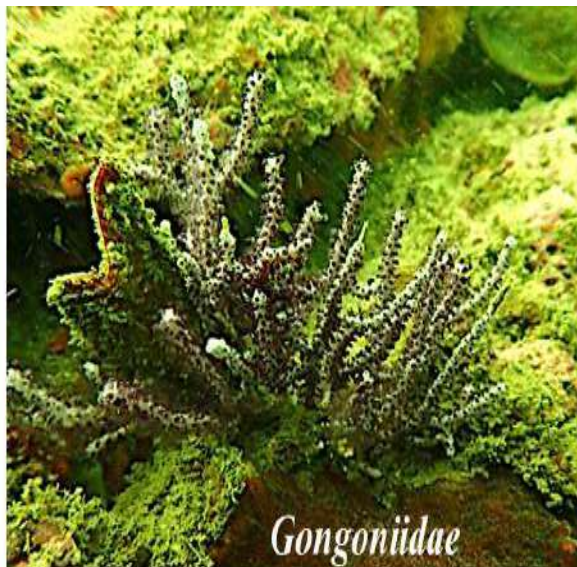
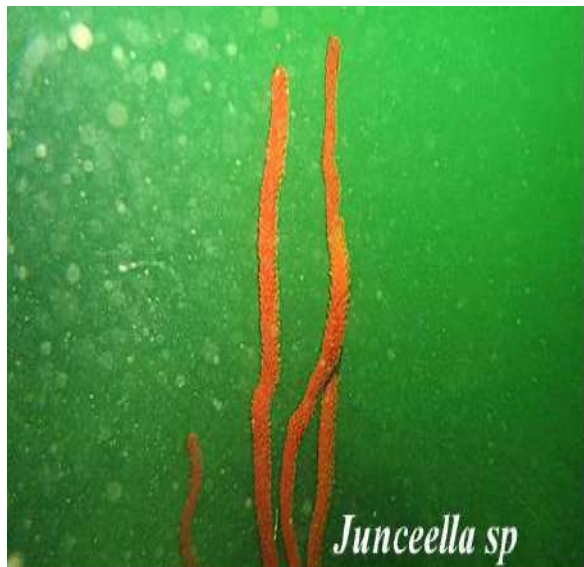

Plate 5: Other Fauna recorded during the underwater survey, Grande Island

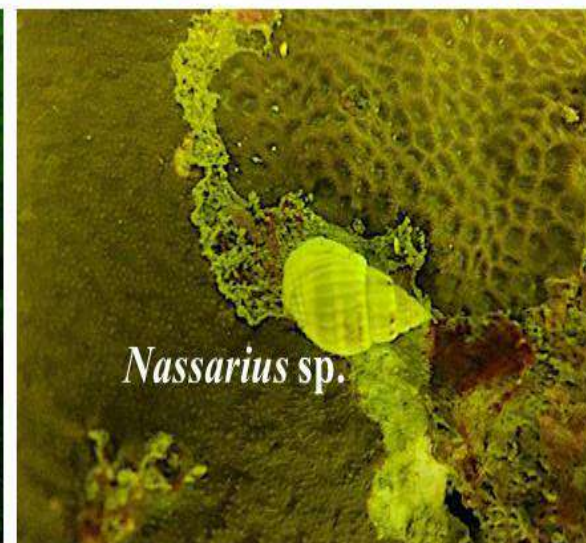
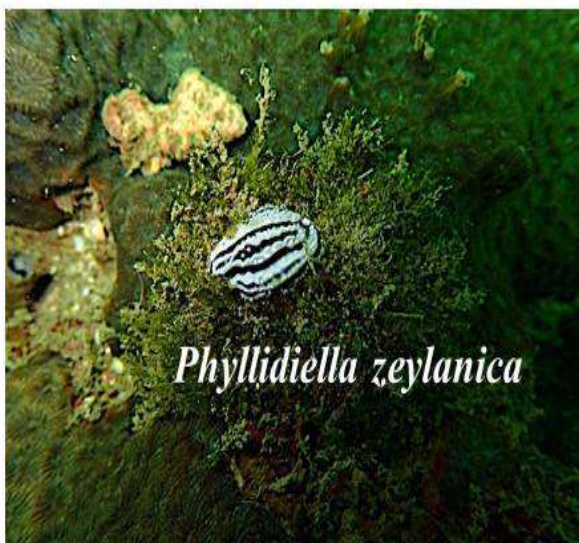
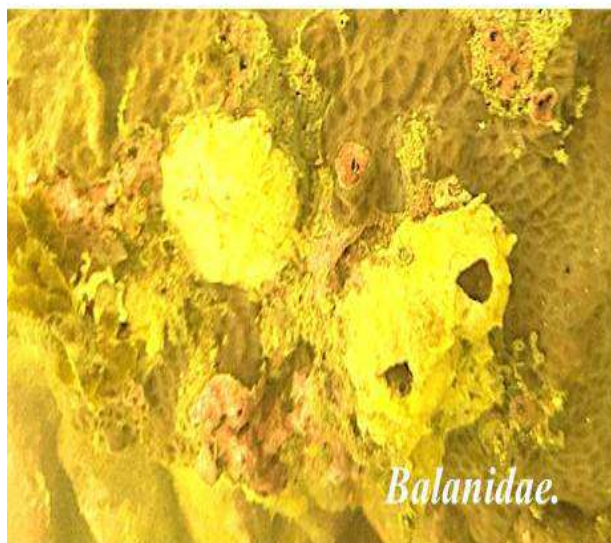
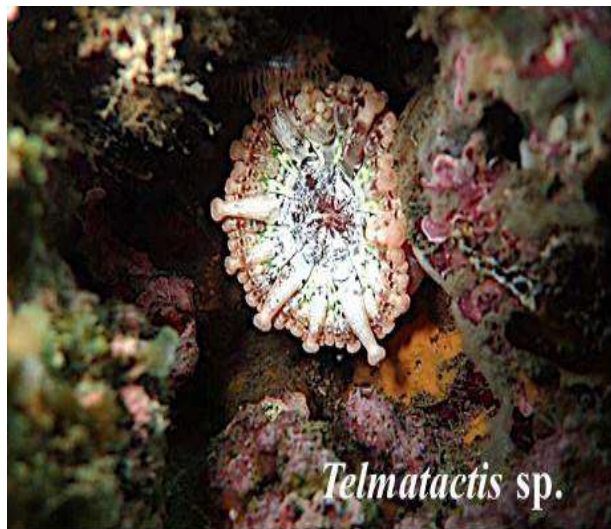

Plate 5 (Continued): Other Fauna recorded during the underwater survey, Grande Island



Plate 6: Corals recorded during the underwater survey, Grande Island

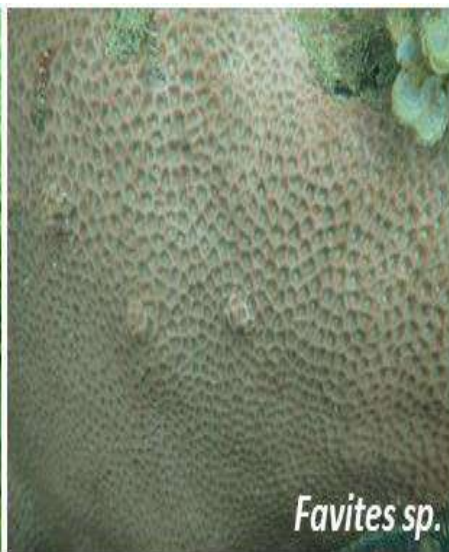
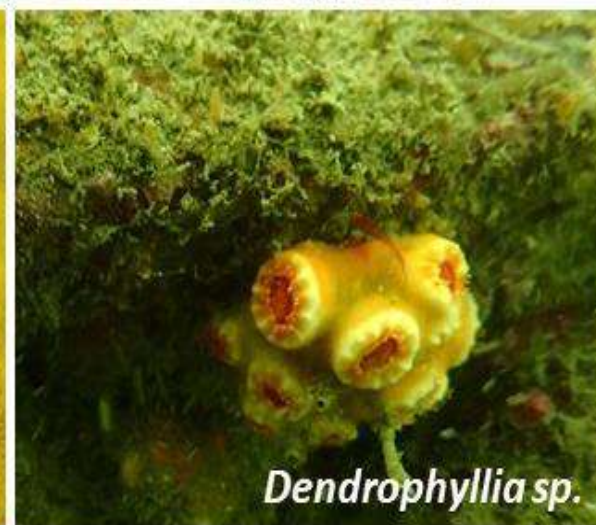

Plate 6: (Continued): Corals recorded during the underwater survey, Grande Island



3.3. Non-Invasive Biodiversity Assessment- Water sample

3.3.1. NGS Raw Sequences Submitted to NCBI

The raw sequences were submitted to the NCBI and the details of the submission are listed below in **Table 7**.

Table 7: The details of Sequence Read Archive (SRA) submission in the NCBI for the generated Grande island dataset.

Sample	Location (Refer to the table for the co-ordinates)	Files	SRA Submission number
A1GI	Coral Garden	Read 1: Forward Read 2: Reverse	SRR24986631
A3GI	Lobster Avenue	Read 1: Forward Read 2: Reverse	SRR24986633
A4GI	Dog Fish Alley	Read 1: Forward Read 2: Reverse	SRR24986632

3.3.2. Quality Assessment of the Sequences Generated

The raw sequences imported in Qiime2 (v qiime2-2025.5) was first evaluated for the Q-Score or Phred Score obtained. All the six multiplexed raw reads were imported as qiime2 attributes (.qza), typically for one sample, two files consisting of forward and reverse are often referred as R1 and R2 reads. These were visualized as a cumulative Phred Score for Forward and Reverse reads (**Figure 11**). For all the 3 samples the Q score was above 30 and considered to be good quality in DNA sequencing. The clustered OTUs were rarefied to confirm the OTUs increasing curve saturated at sequencing depth. The graph shows that the saturation point for sequence depth were 12000 whereas the lowest feature count was 16837 for sample collected from the Coral Garden, which shows that all the samples have been sufficiently sequenced to represent its diversity (**Figure 12**).

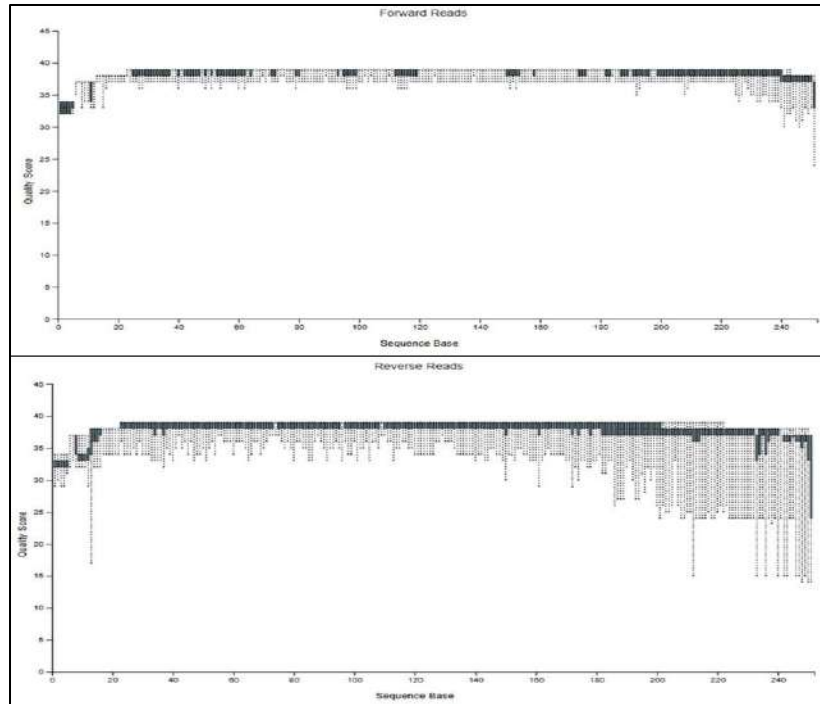

Figure 11: Q Score or Phred Score Plot for the sequences generated cumulative

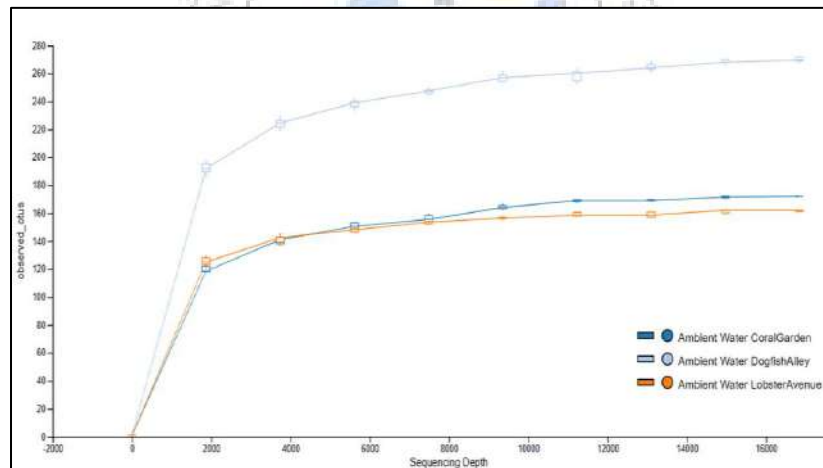

Figure 12: Alpha Rarefaction (OTUs observed vs. Sequencing Depth)

3.3.3. Taxonomic Assignment

After denoising using **dada2** and clustering using **vsearch** with 97% similarity, the sequences were assigned to taxonomy using pre-formatted database of Cytochrome Oxidase Subunit 1 gene (MIDORI2 GB255 qiime2 version). In total for all samples, 82.833% reads were unassigned and 17.166% were for assigned reads. To further analyze the taxonomy data obtained from the samples, the unassigned reads were filtered out along with the non-targeted taxa (e.g., Insects, Fungi). The

filtered taxonomic data was then plotted for the visualization to Phylum level with relative frequency of occurrence (**Figure 13**).

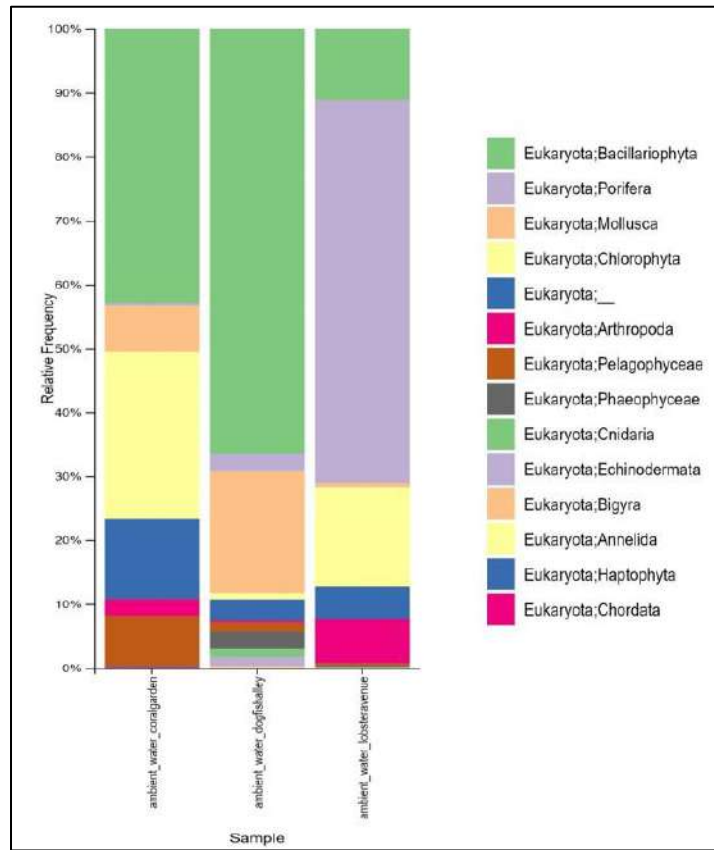

Figure 13: Taxonomy Bar plot- Phylum Level

4. Discussion

From the results of the LIT Survey, the live and dead corals were not spatially exclusive. This study provides a baseline for the macroalgae presence in the different coral reef sites surveyed using the LIT method, a major competitor for the substratum with corals. The relative abundance of biophysical parameters within a site would be helpful to assess the reef health in a particular site. Along with live, dead corals and macroalgae, coral associates were also photographed and identified at the genus level based on morphological features mentioned in Annexure I (**Table A 1** and **Table A 3**). In total, 33 coral associates were identified, including sea urchins. Based on the underwater photos, the corals were identified to the genus level. In total, the underwater survey photographs could capture 14 genera (**Table A 4**) that were also reported in the previously available reports on the Grande Island (Manikandan et al., 2016; Patankar et al., 2018). In addition, as part

of non-destructive sampling, the genomic material was successfully isolated from the water samples collected to assess the reef biodiversity. The isolated genetic material (DNA), such as environmental DNA (eDNA) water samples were successfully amplified and sequenced for the short gene fragment of COI gene of approx. 350 base pair. The majority of the taxonomy identification from the eDNA water sample collected were, microalgae followed by macro-algae (Different assignments at levels of taxonomy; *Phaeophyceae*, *Chordariaceae*, *Fucales*, *Sargassum*, *Bifurcaria bifurcate*). Interestingly few fauna considered as cryptic species were also observed, *Calanoida*, *Centropagidae* and *Terebellida*. And three assignments to sponges to different levels of taxonomy, at Class level *Desmospongiae*, Order level *Suberitida* and at genus *Cliona*. Few other metazoa identifications were also observed similarly, *Ellisellidae* (soft corals), *Hydrozoa*, *Zanclaea giancaloi*, *Galathea Mauritiana*, *Dendostrea* and *Trochidae*.

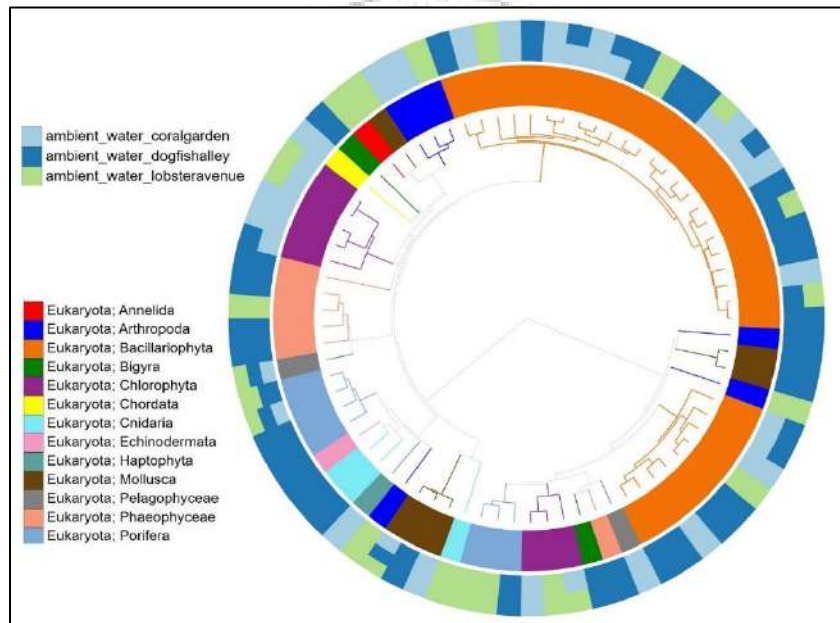

Figure 14: Cladogram showing OTUs (COI gene) with their phylogenetic relationship, taxonomic assignment of the sampling sites

The cladogram was generated to relate the sample data, phylogenetic relationships and respective taxonomic assignments. The inner-most space in the cladogram represents the phylogenetic relationships between the OTUs generated followed by taxonomic assignments to the OTUs and outer-most ring represents the presence of taxa in a particular sampling location. The legends provided within the figure can be differentiated based on the colors (**Figure 14**).

The micro and macro-algae together contributed to 57% of the total taxonomic identification from the water samples collected in present data. This methodology used in this present study can be adopted for the surveillance of the health of the coral habitat environment. According to the (Done, 1992) explanations on algal production and community structure, increased grazing and denuding by herbivores fauna will reduce the algal biomass in a habitat. The largest biomass of algae were represented by the presence of macroalgae and the lowest was represented by turf and crustose algae (Done, 1992). Thus, the current biodiversity assessment in the present study, will help assess the community shifts in the coral reef environments over temporal and spatial variations.

The importance of rapid biodiversity assessment in the current study was also explained with the results from the eDNA metabarcoding from different sites. Interestingly, eDNA-based experiment in this study identified cryptic fauna and sponges which are understudied in the Grande island coral habitats. eDNA-based biodiversity assessment will reduce the cost of the equipment and manpower to assess the health of coral reefs. Furthermore, the validation and replication of the study have to be carried out by comparing the data with the ARMS structures deployed in six sites, will be considered in the scope of future studies.

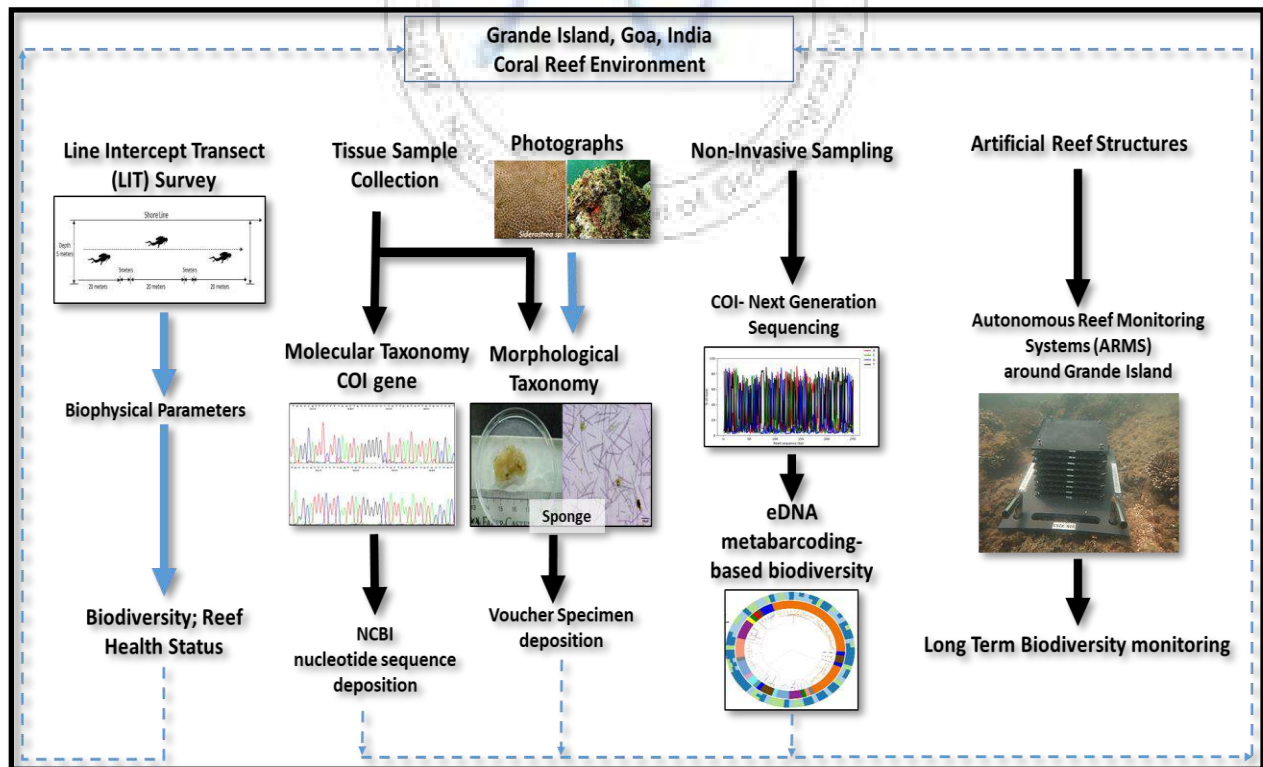

Figure 15: Overview of the work accomplished

5. Outcomes and Proposed Future Management Practices

1. The visibility in the coral habitat ecosystems is considered to be a major hurdle in conducting underwater surveys in the Grande island. Along the southwest coast of India, patchy reefs exist which are underexplored. Proper evaluation and monitoring need to be implemented on these patchy reefs, one among them is the Grande Island, Goa. The Grande Island is uninhabited yet still suffers human intervention as tourists. Regulated tourism in the coral reefs surrounding the Grande island is needed to ensure causing fewer disturbances to the ecosystem is recommended. Following are a few major management practices:
 - a. Boat anchor deployment around coral-rich sites should be avoided.
 - b. Tourists should be explained the importance of the coral reef environment.
 - c. Proper disposal of wastes, etc.
2. Sediment texture in the study area was primarily silty which means the sediment will take time to settle down and have more chances to be carried to the nearby areas including corals habitat surrounding the Grande island. The underwater survey in the present study was confined to the months of December and January. Siltation was observed as one of the bio-physical parameters. This certainly will put the ecologically sensitive habitat at great risk and requires to be monitored periodically in these regions to establish baseline information. High sedimentation rate would increase coral mortality and also influence the macroalgae density. The environmental factors should also be considered since the water current plays a major role in carrying out nutrient-enriched water away and towards the island's reef environment. Moreover, the physical disturbance not only causes re-suspension of sediments and rapid release of nutrients to the water column (Jones and Candy 1981) but may also release toxic substances which will affect the sedimentary and planktonic fauna.
3. Continuous reef monitoring should be carried out considering both temporal and spatial variations using eDNA-based rapid assessment. The abundance of seaweed biomass and coral abundance to understand the marine environmental health status around the Grande island should be assessed by periodic seasonal investigations.
4. It is proposed to conduct a regular reef check program for Grande Island, Goa, a tourist hotspot in Goa. Goa forest department should proactively conduct regular monitoring of reef checks at Grande island to review and improve the conservation efforts. Community based monitoring programs can be initiated to educate, train and engage voluntary

participation of NGOs, educational institutes, industries and volunteers for working towards sustainable management of coral reefs in Goa. This reef check program will be helpful in monitoring and report the health status of the reefs in Goa. The report generated would also be used to scientifically investigate the problems to ensure better governance of coral reefs and marine resources. Involving the local communities, would be the first step to attract local people in coral-reef management activities.

Coral reef check monitoring plan: The abundance of particular organism in reef environment is considered as indicator organisms reflecting the condition of a particular reef. The information on the reef would be gathered using reef-check program. In general reef check teams made up of a scientific and other sector people with an interest in re-creational activities will come together to collect, more than 30 measures of socio-economic, environmental conditions and human impacts on the site. A measure of different substrate types, invertebrate counts and fish counts using belt transect will be recorded in the reef check program accompanied with a biologist. Basically, a team will be made of 6 members with 3 buddies to collect the above-mentioned data. Once data will be generated, scientific community will intervene to discuss the management practices. The continuous impacts of tourists on a particular site requires to be monitored certainly once a month, the Grande Island which is a hotspot for tourism for recreational activities requires frequent monitoring and scientific supervision on the data collected. This creates responsible tourism and awareness to local communities. Thus, three goals should be there by implementing Reef Check program, Education, Data Collection and Coral reef management with scientific analysis.

References

1. Ajmal Ali, M., Gyulai, G., Hidvégi, N., Kerti, B., Al Hemaid, F. M., Pandey, A. K., & Lee, J. (2014). The changing epitome of species identification - DNA barcoding. *Saudi J Biol Sci*, 21(3), 204-231. doi:10.1016/j.sjbs.2014.03.003
2. Beheregaray, L. B., & Caccone, A. (2007). Cryptic biodiversity in a changing world. *Journal of Biology*, 6, 9 - 9.
3. Carvalho, S., Aylagas, E., Villalobos, R., Kattan, Y., Berumen, M., & Pearman, J. (2019). Beyond the visual: Using metabarcoding to characterize the hidden reef cryptobiome. *Proceedings of the Royal Society B: Biological Sciences*, 286, 20182697. doi:10.1098/rspb.2018.2697

4. Done, T. J. (1992). Phase shifts in coral reef communities and their ecological significance. *Hydrobiologia*, 247(1), 121-132. doi:10.1007/BF00008211
5. Geller, J., Meyer, C., Parker, M., & Hawk, H. (2013). Redesign of PCR primers for mitochondrial cytochrome c oxidase subunit I for marine invertebrates and application in all-taxa biotic surveys. *Mol Ecol Resour*, 13(5), 851-861. doi:10.1111/1755-0998.12138
6. Hodgson, G. (2000). Coral reef monitoring and management using Reef Check. *Integrated Coastal Zone Management*, 1, 169-179.
7. Huber, J. T. (1998). The importance of voucher specimens, with practical guidelines for preserving specimens of the major invertebrate phyla for identification. *Journal of Natural History*, 32(3), 367-385. doi:10.1080/00222939800770191
8. Knowlton, N., Brainard, R., Fisher, R., Moews, M., Plaisance, L., & Caley, M. (2010). Coral Reef Biodiversity. In (pp. 65-78).
9. Knowlton, N., & Jackson, C. (2001). The Ecology of Coral Reefs.
10. Leray, M., & Knowlton, N. (2016). Censusing marine eukaryotic diversity in the twenty-first century. *Philos Trans R Soc Lond B Biol Sci*, 371(1702). doi:10.1098/rstb.2015.0331
11. Leray, M., Yang, J. Y., Meyer, C. P., Mills, S. C., Agudelo, N., Ranwez, V., Machida, R. J. (2013). A new versatile primer set targeting a short fragment of the mitochondrial COI region for metabarcoding metazoan diversity: application for characterizing coral reef fish gut contents. *Front Zool*, 10, 34. doi:10.1186/1742-9994-10-34
12. Manikandan, B., Ravindran, J., Mohan, H., Periasamy, R., Murali, R. M., & Ingole, B. S. (2016). Community structure and coral health status across the depth gradients of Grande Island, Central west coast of India. *Regional Studies in Marine Science*, 7, 150-158. doi:<https://doi.org/10.1016/j.rsma.2016.05.013>
13. Meyer, C. P., & Paulay, G. (2005). DNA Barcoding: Error Rates Based on Comprehensive Sampling. *PLOS Biology*, 3(12), e422. doi:10.1371/journal.pbio.0030422
14. Mies, M., Francini-Filho, R. B., Zilberberg, C., Garrido, A. G., Longo, G. O., Laurentino, E., Banha, T. N. S. (2020). South Atlantic Coral Reefs Are Major Global Warming Refugia and Less Susceptible to Bleaching. *Frontiers in Marine Science*, 7. doi:10.3389/fmars.2020.00514
15. Ng, W., Cheang, C., Kei, K., Tsoi, K., & Chow, W. (2013, July). AFCD workshop: Hong Kong Reef Check: A programme to promote sustainable management of corals and science

education. Paper presented at the 3rd International Conference of East-Asian Association for Science Education, The Hong Kong Institute of Education, China.

16. Nichols, P., Timmers, M., & Marko, P. (2021). Hide 'n seq: Direct versus indirect metabarcoding of coral reef cryptic communities. *Environmental DNA*, 4. doi:10.1002/edn3.203
17. Palomino-Alvarez, L. A., Vital, X. G., Castillo-Cupul, R. E., Suárez-Mozo, N. Y., Ugalde, D., Cervantes-Campero, G., Guerra-Castro, E. J. (2021). Evaluation of the Use of Autonomous Reef Monitoring Structures (ARMS) for Describing the Species Diversity of Two Coral Reefs in the Yucatan Peninsula, Mexico. *Diversity*, 13(11), 579. Retrieved from <https://www.mdpi.com/1424-2818/13/11/579>
18. Ransome, E., Geller, J. B., Timmers, M., Leray, M., Mahardini, A., Sembiring, A., Meyer, C. P. (2017). The importance of standardization for biodiversity comparisons: A case study using autonomous reef monitoring structures (ARMS) and metabarcoding to measure cryptic diversity on Mo'orea coral reefs, French Polynesia. *PloS one*, 12(4), e0175066. doi:10.1371/journal.pone.0175066
19. Reaka, M. (1997). The global biodiversity of coral reefs: a comparison with rainforests.
20. Thomsen, P. F., & Willerslev, E. (2015). Environmental DNA – An emerging tool in conservation for monitoring past and present biodiversity. *Biological Conservation*, 183, 4-18. doi:<https://doi.org/10.1016/j.biocon.2014.11.019>.

Annexure I

Table A 1 : Fish Fauna recorded during the underwater survey of the Grande Island, Goa, India

S No	Scientific Name	IUCN Status
1	<i>Gymnothorax favagineus</i>	Least Concern
2	<i>Chrysiptera biocellata</i>	Least Concern
3	<i>Scorpaenidae</i>	Least Concern
4	<i>Scolopsis vosmeri</i>	Least Concern
5	<i>Chaetodon collare</i>	Least Concern
6	<i>Abudefduf vaigiensis</i>	Least Concern
7	<i>Enneapterygius sp.</i>	Least Concern
8	<i>Pseudochromis caudalis</i>	Least Concern
9	<i>Karalla daura</i>	Not Evaluated
10	<i>Caesionidae</i>	Least Concern
11	<i>Pempheris mangula</i>	Not Evaluated
12	<i>Amblygobius sp.</i>	Least Concern
13	<i>Scolopsis sp.</i>	Least Concern
14	<i>Epinephelus awoara</i>	Data Deficient
15	<i>Halichoeres nigrescens</i>	Least Concern
16	<i>Odonus niger</i>	Least Concern
17	<i>Chelonodon patoca</i>	Least Concern
18	<i>Cephalopholos formosa</i>	Least Concern
19	<i>Apolemichthys xanthurus</i>	Least Concern
20	<i>Sufflamen verres</i>	Least Concern
21	<i>Syngathoides sp.</i>	Least Concern

Table A 2: Macroalgae recorded during the underwater survey of the Grande Island, Goa

S No	Scientific Name	IUCN Status
1	<i>Sargassum sp.</i>	Data Deficient
2	<i>Padina sp.</i>	Data Deficient
3	<i>Spatoglossum asperum</i>	Data Deficient
4	<i>Polysiphonia sp.</i>	Not Evaluated
5	<i>Caulerpa scalpelliformis</i>	Not Evaluated
6	<i>Caulerpa nummularia</i>	Not Evaluated
7	<i>Caulerpa sertularioides</i>	Not Evaluated
8	<i>Amphiroa anceps</i>	Data Deficient

Table A 3: Other fauna recorded during the underwater survey of the Grande Island, Goa

S No	Scientific Name	IUCN Status	Wild life Act 2022, Govt of India
1	<i>Telmatactis sp.</i>	Data Deficient	
2	<i>Goniobranchus trimarginatus</i>	Not Evaluated	
3	<i>Tenguella granulata</i>	Not Evaluated	
4	<i>Balanidae.</i>	Data Deficient	
5	<i>Phyllidiella zeylanica</i>	Not Evaluated	
6	<i>Nassarius sp.</i>	Not Evaluated	
7	<i>Elysia ornate</i>	Not Evaluated	
8	<i>Trochus sp.</i>	Not Evaluated	
9	<i>Holothuria leucospilota</i>	Least Concern	Schedule I
10	<i>Stomopneustes variolaris</i>	Not Evaluated	
11	<i>Stomopneustes toreumaticus</i>	Not Evaluated	
12	<i>Turbinella pyrum</i>	Not Evaluated	

Table A 4: Corals of the Grande Island, Goa

S No	Scientific Name	IUCN Status	Wild life Act 2022, Govt of India
1	<i>Coscinaraea sp.</i>	Near Threatened	Schedule I
2	<i>Cyphastrea sp.</i>	Least Concern	Schedule I
3	<i>Favites sp.</i>	Near Threatened	Schedule I
4	<i>Siderastrea sp.</i>	Least Concern	Schedule I
5	<i>Coscinaraea sp.</i>	Near Threatened	Schedule I
6	<i>Dipsastrea sp.</i>	Not Evaluated	Schedule I
7	<i>Leptastrea sp.</i>	Near Threatened	Schedule I
8	<i>Pseudosiderastrea sp.</i>	Near Threatened	Schedule I
9	<i>Goniopora sp.</i>	Near Threatened	Schedule I
10	<i>Plesiastrea sp.</i>	Least Concern	Schedule I
11	<i>Porites sp.</i>	Near Threatened	Schedule I
12	<i>Turbinaria sp.</i>	Vulnerable	Schedule I
13	<i>Bernadopora sp.</i>	Not Evaluated	Schedule I
14	<i>Dendrophyllia sp.</i>	Data Deficient	Schedule I

Table A 5: Soft Corals of Grande Island, Goa

S No	Scientific Name	IUCN Status	Wild life Act 2022, Govt of India
1	<i>Junceella (Genus)</i>	Not Evaluated	Schedule I
2	<i>Gorgoniidae (Family)</i>	Not Evaluated	Schedule I

Annexure II Permission Letters

FORM XII
(See Rule 22(3))
Special Purpose Permit under Section 12 of the
Wildlife (Protection) Act, 1972

Subject to the provisions of the Wildlife (Protection) Act, 1972 and the rules made there under Special Purpose Permit is hereby granted to **Dr. Dineshram Ramadoss, Scientist, Biological Oceanography Division, CSIR-National Institute of Oceanography, Donapaula, Goa** from 12th October 2022 to 31st October 2023 to carry out study on Assessing the hidden Marine cryptic bentic Biodiversity of Coral Reef ecosystems of Grande Island, Goa for the scientific research purpose.

Sr. No	Name of the plants/ animals (including birds, reptile, etc) / Name of Plant/ Faunal species	Details								Area where collection is permitted	
		No.	Sex of the animals				Size of the animals				
			Male No.	Female No.	Adult No.	Young No.	No.				
1	2a	2b	3a(1)	3a(2)	3a(3)	3a(4)	3b(1)	3b(2)	3b(3)	3b(4)	4
1	Scleractinian coral nubbins						Scleractinian coral nubbins				Grande Island, Goa

2. The permit fees of Rs. **NIL** has been paid. The permit is required for scientific research.

3. (1) (a) The particulars of the permit holder where the permit holders are not of Government Department / Organization / Institution are as follows:- **N.A.**

SPECIMEN SIGNATURE OF THE PERMIT HOLDER

(i) 





(b) Passport size photograph of the Special permit holder duly attested by the permit issuing authorities – **Attached.**

(2) Where the permit holder is a Government Department / Organization / Institution – Name and full address of the Department / Organization / Institution - **CSIR-National Institute of Oceanography, Donapaula, Goa 403004**

4. The permit holder shall strictly abide by the provisions of the Act, rule made there under and the conditions laid down below:

(1) The permit holder shall not collect:-

- (i) Any wildlife unless specifically permitted.
- (ii) and in area other than specified in this permit.

13) Besides the penalties that may be imposed on them under the provisions of the Act, the permit holder shall pay such such penalties and compensation of violation of the conditions of the permit issued as may commit under the Act and the rules made there under as may be decided by the Chief Wildlife Warden, failing which his licence fee shall stand forfeited to the Government and the licence issued to him shall stand cancelled and such arrears as may be due from him as a result of the penalties and compensation by the Chief Wildlife Warden shall be recoverable from him as arrears of land revenue.

(14) Any deviation from the above conditions shall lead to cancellation of the permit and action as per Acts / Rules in force shall be taken.

This issues with the approval of Chief Wildlife Warden.

Santosh H. Fadte
Dy. Conservator of Forests
Planning & Statistics

No.2-66-WL-RESEARCH PERMISSIONS-FD-Vol.VI 3079

Place:- Panaji – Goa.

Date:- 13 /10/2022

To,

✓ Dr. Dineshram Ramadoss, Scientist,
Biological Oceanography Division,
CSIR-National Institute of Oceanography,
Donapaula, Goa

Copy to:-

1. The Dy. Conservator of Forests, Wildlife & Eco-tourism (/South) Division / South Goa Division/ Research & Utilisation Division, Margao-Goa for information and necessary action
2. The Head of Department, Biological Oceanography Division, CSIR-National Institute of Oceanography, Donapaula, Goa, for information.