

ISSF Coach Course

PISTOL SHOOTING



by Željko Todorović

© 2020 Željko Todorović

TABLE OF CONTENTS

ISSF Coach Course

THEORETICAL PART

| | |
|---|----|
| 1. INTRODUCTION | 1 |
| 2. LIFTING TECHNIQUE | 4 |
| PRECISION | 4 |
| Vertical movement to target (for precision disciplines and SP RF) | |
| DYMANIC | 9 |
| Horizontal movement with transition (RFP) | |
| 3. SIGHTING TECHNIQUE | 17 |
| PRECISION | 17 |
| DYMANIC | 24 |
| Sighting techniques for SP RF | |
| Sighting techniques for RFP | |
| 4. TRIGGERING TECHNIQUE | 27 |
| PRECISION | 30 |
| DYNAMIC | 32 |
| 5. FOLLOW THROUGH | 33 |
| 6. SHOOTING IN DIFFERENT WEATHER CONDITIONS | 35 |
| 7. WEAPON MAINTENANCE | 42 |

PRACTICAL PART

| | |
|--|----|
| 1. HOW TO AIM AND SIGHT | 45 |
| 2. APPROACHING CENTER OF THE TARGET. | 49 |
| 3. GRIP AND GRIPPING | 53 |
| 4. DETECTING CRITICAL POINTS BASED ON SHOT GROUP | 54 |
| 5. CORRECTION OF THE MOST COMMON MISTAKES | 58 |
| 6. TACTICS IN SHOOTING | 67 |
| 7. SHOOTING DIARY | 73 |
| 8. USE OF OPTOELECTRONIC EQUIPMENT | 76 |
| 9. WEAPON AND AMMO TESTING. | 84 |
| BIBLIOGRAPHY | 91 |

1. INTRODUCTION

During the previous course we were dealing with the position of the various pistol disciplines. One can see it as the preparation for carrying out three major tasks in shooting sport: lifting, sighting, and the triggering action. Considering them as three separate functions would not be wrong, but absolutely incorrect. Anyhow, before trying to make a coordinated action between these three tasks, for better understanding we will make an artificial separation of this complex action and try to describe each technique separately.

Taking into consideration that in the Olympic program we are dealing with basically 3 pistol disciplines, Air Pistol (Men, Women and Team Event), Sport Pistol (precision & rapid stage), and Rapid Fire Pistol (8, 6 & 4 seconds) which requires different lifting, sighting and triggering techniques. Each of them has two to four different models. A number of combined applications is far too many to be described and analyzed as separate techniques.

In this document we will try to describe major requirements and technical solution applications, dividing them into precision and rapid stage techniques.

During the residential course, we will conduct workshops dealing with different specific models of lifting-sighting-triggering technique.

2. LIFTING TECHNIQUE

PRECISION

In all precision pistol disciplines (air pistol, precision stage of sport pistol) we differentiate two major techniques and their individual variations. In this document they are called “High Technique” (HT) and “Low Technique” (LT).

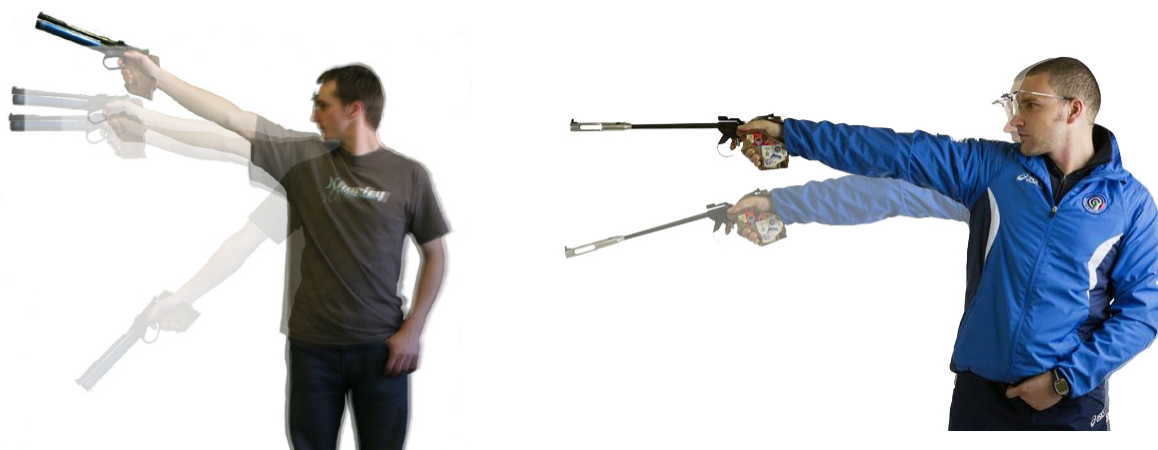

Both techniques have a common function – to provide a minimum arc of movement in the final aiming area and secure stability of the gun during the triggering process, avoiding any lateral or vertical forces that can result in a non-desired movement of the barrel.

Another important requirement for HT and LT is that the gun has to be lifted in such a manner that it provides a line of movement identical to a line passing vertically through the centre of the target. Experience and tests done with optoelectronic devices (Scatt) show that a lateral approach

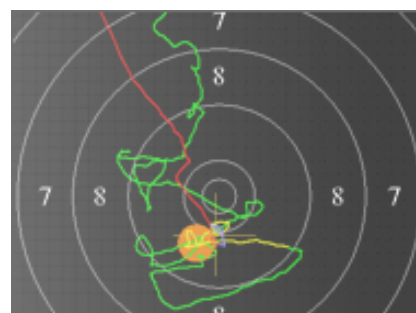

to the final aiming area creates a tendency to fire the shot in the direction of the approach, outside of the “ten area”.

HT can be described as a technique consisting of 4 stages:

- Taking the ready position, where the following technical elements are performed :
 - Correct gripping technique
 - Starting the lifting position of the gun aligning with the line of shooting
 - Correct head positioning
 - Building optimal tension of Deltoid muscle for concentric contraction
 - Locking wrist and elbow joint
- Lifting the gun through the middle of the target above the “bull’s eye”, within the limits defined by safety rules. When performing this sequence, the athlete is securing:
 - that lateral forces of the muscles holding the shoulder joint are equally engaged, providing optimal conditions for “zero lateral activity” of the shoulder joint
 - providing optimal conditions for activity of the muscle Deltoideus, for the next sequence of the lifting technique - eccentric contraction
 - performing the first stage of pistol stabilisation
- Lowering the gun through the middle of the target into the final aiming area. Usually, this sequence is divided in two stages:
 - Lowering the pistol to the point just above the “bull’s eye” where the second stage is to stabilize the weapon regarding the arc of the movement, sighting elements positioning, and first trigger stage. This phase will be the subject of a

more detailed description in the chapters describing sighting and triggering techniques.

- Second stage is represented by travel through the middle of the target, with deceleration of the movement from the position of the “10” towards the final aiming area.
- Stabilizing the movement of the gun in the final aiming area, combined with final aiming and triggering technique (these processes will be described later).

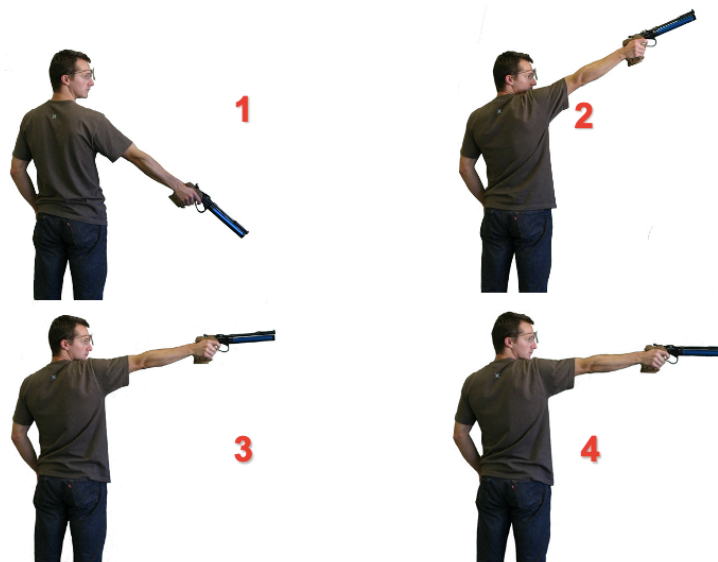

HT is the most commonly used technique among pistol shooters.

For a better understanding of the above-described, let us first elaborate anatomic and biomechanical functionality of muscle Deltoideus.

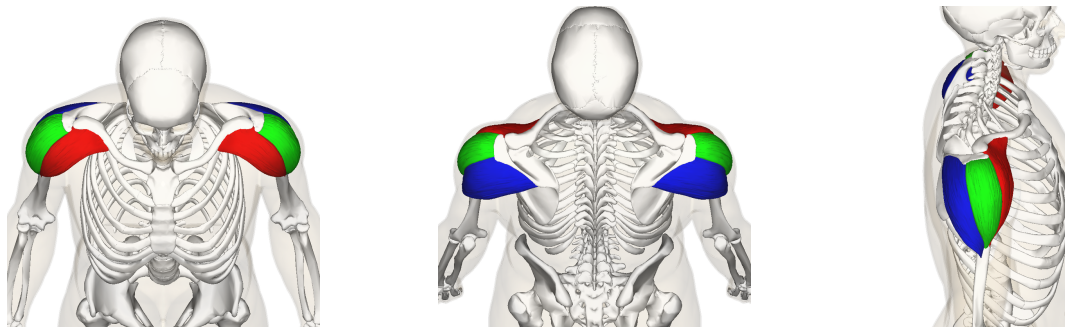

Deltoid muscle has three parts (heads).

The anterior or clavicular fibers arise from most of the anterior border and upper surface of the lateral third of the clavicle. The anterior origin lies adjacent to the lateral fibers of the pectoralis major muscle as do the end tendons of both muscles.

Intermediate or acromial fibers arise from the superior surface of the acromion process of the scapula.

Posterior or spinal fibers arise from the lower lip of the posterior border of the spine of the scapula.

When all its fibers contract simultaneously, the deltoid is the prime mover of arm abduction along the frontal plane. The arm must be medially rotated for the deltoid to have maximum effect. This makes the deltoid an antagonist muscle of the pectoralis major and latissimus dorsi during arm adduction.

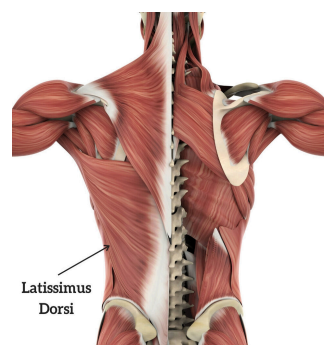
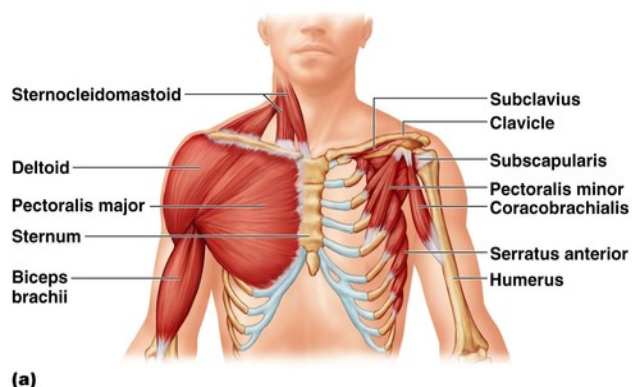

Eccentric contraction is one that is engaged when arm is being lowered.

Concentric contraction is the other that is engaged, when arm is raised.

The reason for the wide implementation of HT is the fact that the muscles involved, mainly the deltoids, resist the weight of the arm and gun during lowering the arm from above the target. This is an eccentric contraction, which gives **more control over speed and position** than a concentric action, being a dominant Deltoid activity during LT. At the same time, the shoulder joint is placed in the optimal physiological position.

LT is an equally efficient technique in terms of score, but is not so commonly used among shooters. In comparison with HT, LT has three stages:

- Taking ready position
- Lifting the gun in the final aiming area, in the line passing through the middle of the target
- Stabilizing the movement of the gun in the final aiming area

Analyzing the advantages and disadvantages, we can see that HT requires more complex movements and significant use of more energy for its delivery than in LT. In saying that, HT is more complex for learning than LT. On the other hand, HT is providing easier conditions for the function of the shoulder joint and three parts of the Deltoid muscle, which is a great advantage in comparison to the LT. As we will see in the following part of this document, LT is the ultimate technique for dynamic pistol disciplines (rapid stage of sport pistol and rapid fire pistol). We can agree that a precision shooter who competes in both kinds of pistol shooting can find their advantage by learning just one similar lifting technique.

DYMANIC

While in precision shooting we have two lifting techniques at our disposal, dynamic disciplines do not have that luxury. Due to the time limit rules, the lifting technique has to provide the travel of the gun to the final aiming area in the optimally shortest possible time.

Despite the short time available for the lift, we can differentiate two major lifting techniques applied in dynamic disciplines: Fast-Slow Technique (FST) and Fast Technique (FT).

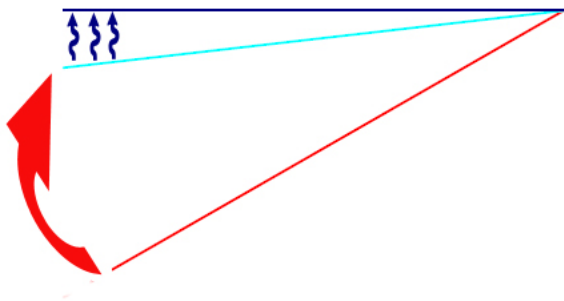

In FST, the lifting process is developed through a fast movement over the first $\frac{3}{4}$ of the total movement necessary to reach the final aiming area, followed by a deceleration in its last $\frac{1}{4}$. Namely, fast

movement is generated from the appearance of the green light on the target and lasts until the gun arrives at the lower edge of the target (or a bit lower). From this moment the movement is significantly and constantly slowing, providing slow and steady arrival in the final aiming area, which is in the middle of the target or a bit lower.

FT does not recognize any change in rhythm and speed from its start to the end of the movement, but an abrupt and well-controlled stop in the final aiming area.

The advantage of FST is the fact that the gun is moving with significantly slower motion when reaching the final aiming area, allowing the shooter to apply better control over the arc of movement of the pistol. Theoretically, chances for delivery of the correct shot are increased. At the same time, disadvantage consequence will occur with reduced time for final aiming adjustment if needed (some situations will be subject to further discussion).

FT shooters have to deal with an increased risk of a greater arc of movement of the gun, as well as significant vibrations caused by a violent stop in the final aiming area. This is the major disadvantage of this technique. At the same time, this technique is creating an advantage in the form of additional aiming time in the final aiming area, thus creating the possibility for corrections and adjustments if needed before the shot is delivered.

Considering that SP rapid stage is dealing only with a vertical movement during a series of 5 shots, both techniques can be equally efficient. The choice of technique is an individual decision based on the shooter's reaction time, physical characteristics, personal perception of time-lapse, and habits created from the beginning of a career. Nevertheless, it is rather common that shooters adopt/switch to a different technique in the process of developing their skills throughout their career. This should not be seen as an experimental change but as the natural development of the athlete.

The second aspect of the lifting technique in SP rapid stage is the process of preparation for the next shot i.e. 2, 3, 4 & 5. Preparation for those shots is starting after firing the first shot, by bringing the sighting elements to the “ten” position and lowering the gun with a slow, smooth movement to the start position. The ideal condition would be to equalize the eccentric and concentric activity of the Deltoid muscle. Simple rule – speed and intensity of lowering the gun should be the same with the speed and intensity of lifting the gun. Lowering the gun is a very important part of the lifting technique - often neglected and forgotten. The result of missing to incorporate the lowering technique will be in the inadequate activity of the Deltoid muscle, gun displacement in a ready position and insufficient readiness for the next shot.

[See the attached video – “SP_2_lifting_sighting”.](#)

In RFP, the lifting technique is just one part of the dynamic movement of the pistol. Due to the fact that after the first shot is delivered, the movement of the pistol has to be transformed into a horizontal movement. Optimal delivery of the first shot is the most crucial factor which determines the outcome of shots 2–5. The logics of the biomechanics would dictate that FST would give an advantage over FT, by producing better control of the gun movement and creating optimal conditions for a smooth transition through targets 2-5. Breaking further horizontal movement in detail, the most crucial part of this process is the transition from target one to target two. The way in which the transition from the first to the second target will be carried out will dictate the outcome of the transition through targets 2–5.

Horizontal movement can be carried out with one of the three major techniques:

- Straight linear movement technique (SLT)

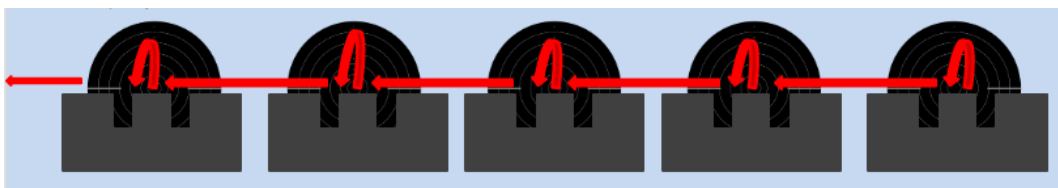

- Concave/convex movement technique (CCT)

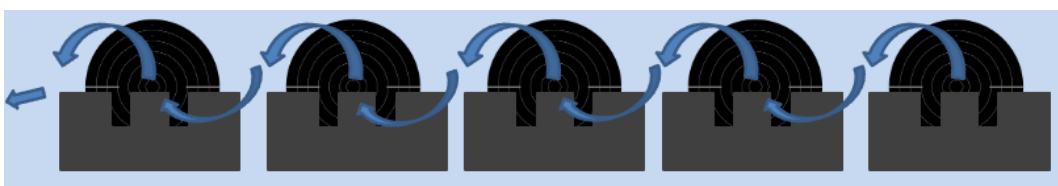

- Tooth-saw movement technique (TST)

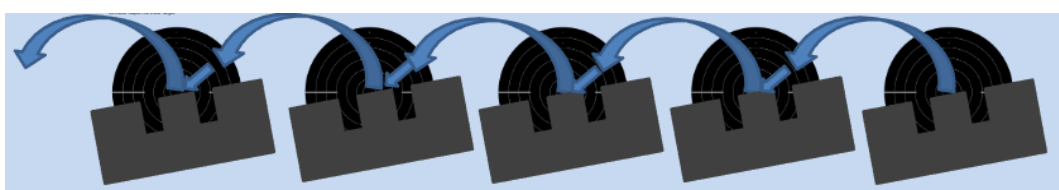

Straight Linear Technique in its definition would give a major benefit as being the most uniformed movement to the next target. At the same time, this technique is demanding a significant use of energy to deal with the accelerated forces produced by firing the shot. This is the greatest disadvantage when managing the movement of the gun into a straight line to the next aiming area of the target.

Convex/Concave Technique is more “shooter friendly” by using the energy produced by the muzzle movement to direct the gun to the aiming zone of the next target. The disadvantages are very similar to those in the previous technique. An additional disadvantage can be found in the fact that the trajectory is not always uniform due to inconsistent characteristics of ammunition.

The tooth-saw Technique is relatively “young”, and has found its application after rules changed in Rapid Fire Pistol discipline – transition to long rifle ammunition and Sport Pistol gun specification (lifting barrel axis and increasing trigger weight resistance). Those changes were pushing forward and looking at changes in all techniques: lifting, sighting, and triggering.

For a better understanding of the differences, advantages, and disadvantages of these lifting techniques, it is necessary to understand the functionality of the pistol action when firing the shot.

At the moment when the shooter overcomes trigger weight resistance, the hammer is hitting the firing pin. The firing pin is hitting into the back end of the cartridge, igniting the small explosive charge in the primer. The primer then ignites the propellant - the main explosive that occupies about two-thirds volume of a typical cartridge. As the propellant chemicals burn, they generate lots of gas very quickly.



The sudden, high pressure of the gas splits the bullet from the end of the cartridge, forcing it down the gun barrel at extremely high speed. It is only the bullet that fires from the gun; the rest of the cartridge stays where it is until it is ejected by the extractor system and the next cartridge is loaded into the barrel. While the bullet is traveling down the barrel it is spinning clockwise due to the grooves inside the barrel which provides more stability to its trajectory. Once the bullet is out of the barrel, the pressure is instantly dropping, while the sliding mechanism is being pushed backward extracting the empty cartridge on the right side of the pistol and mounting the next one into the barrel chamber.



All these physical action forces are resulting the pistol movement **up** **and to the left** when firing the shot.

The above-mentioned explanation is bringing us back to explain the tooth-saw technique advantages and disadvantages. In order to correctly apply this technique, the shooter has to lift the gun with a certain degree of canting. Also, the start of the lifting point is not straight in front of the shooter, but coming laterally, from the right and/or back side of the body. Lift is slightly diagonal and sights are canted from the start until arrival in the middle of the target.

Sure, one could argue that it is not a very good/correct technique and will be appropriate – it is a disadvantage from a precision discipline point of

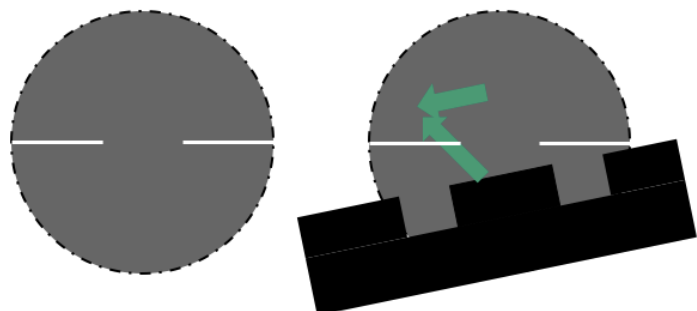

view. But, the advantage will be in the fact that when firing, the gun will, as described previously, travel up and to the left. Actually it will move towards the center of the next target.

In comparison with the two first lifting techniques LST & CCT, where the shooter is lifting the gun straight up, firing, and actively controlling the movement of the gun to the next target, TST is using physical forces of the gun to “propel it” towards the next target.

During the first Course we were elaborating the position of the RFP. For a short time let us revoke some details. There are two major methods to take the correct position. One according to the first target and one according to the third target.

- Advantage of choosing target N°3 as reference alignment target, is offering even distribution of horizontal movement from targets N°1-N°3 and target N°3-N°5, meaning that horizontal movement across 7° travel is equally spread to the right and to the left. This method prevents the tightness of the muscle groups which are engaged in the body's fixation, especially in the lower back, and the distance from the "zero" position to the first i.e., fifth target is the same. The theoretical disadvantage will be that the athlete has to turn approximately 3.5° to the right when assuming the ready position. Due to the rapid vertical lift the athlete is risking lateral displacement of the pistol in reference to the middle of the target.
- When choosing target N°1 as reference alignment target, advantage will be in dismissing above-mentioned disadvantage i.e. it will be more likely to reach the middle of the target in a rapid vertical movement. The first shot has the most important role for the whole series as the movement to the first target is the longest one. Consequently, due to the horizontal travel across the entire 7°, disadvantage is the probability of lowering the gun at the end of the motion on moving the gun from target 1 through 5, i.e. risk of shooting low shots on target 4 and/or 5.

Movement to the next target must be provided through leg muscle activity (groups under knees). Rotation of the body around the axis that is passing through the body's center of gravity is possible only if the muscles that are providing this activity are allowed to freely shorten or extend. They should not be interacting with overwork of the ligaments (which are having a contradictory role), and opposing groups of muscles that are fixating certain parts of the body. Therefore, it is of major interest to loosen the legs by spreading them wider. As mentioned, hip joints are getting “unlocked” to achieve a higher degree of flexibility. It can be found in various older literature statements that rotation is done in/with the rotation of the ankle joint. This statement has no validity in biomechanical and physiological function. Ankle joints cannot rotate! There is a “slack” in this joint that is a maximum of 5°. This means that actual rotation motion is done by lower leg muscles, between knee and ankle, where the pivoting point is located in the hip area.

There are two main horizontal techniques:

- Slow Horizontal Technique (SHT). This technique is carried out evenly, with a slower transition to the next target using one of the three methods mentioned above. The advantage of SHT is in the fact that the movement of the gun can be better controlled when moving to the next aiming zone, while the disadvantage is the reduced time for an eventual correction in the final aiming area.
- Fast Horizontal Technique (FHT). This technique is carried out by a rapid transition to the next target, also using one of the three mentioned methods. Contrary to the previous, the FHT technique is providing the possibility of a correction in the final aiming area, but the transition of the pistol to the next target is insufficient to control.

Taking into account the above, it can easily be concluded that different techniques of the horizontal movement have a common factor. The rotation takes place with the help of muscles below the knee, where the pivoting point is located in the hip area.

In any event, high-level international shooters have efficiently applied either of these techniques. All the above-described techniques, as we will see in the following part of this paper, must be compatible with two more techniques - the sighting and the triggering techniques. Individual abilities and personal preferences will determine which lifting technique will be combined with the rest of the shot delivery techniques.

[See the attached video – “RFP_lifting_sighting”.](#)

Self-evaluating question

Describe lifting techniques in precision disciplines

Describe lifting techniques in dynamic disciplines

3. SIGHTING TECHNIQUE

PRECISION

Before describing and commenting on some of the available sighting techniques, I would like to say a few words on the terminology used in covering this subject. In many different books and papers, there is a great deal of confusion and lack of understanding about what aiming is and what sighting technique is. Very often it is described as the same process or technique, with the same meaning for both.

Aiming picture – is the relationship between the pistol's sighting elements - front & rear sight, and target. Approval of this definition can be found in Yur'yevs statement (1973, p.173),“ ...aiming is an act in which the shooter places the rear sight, front sight, and aiming point in a single line in order to align the gun with the center of the target”.

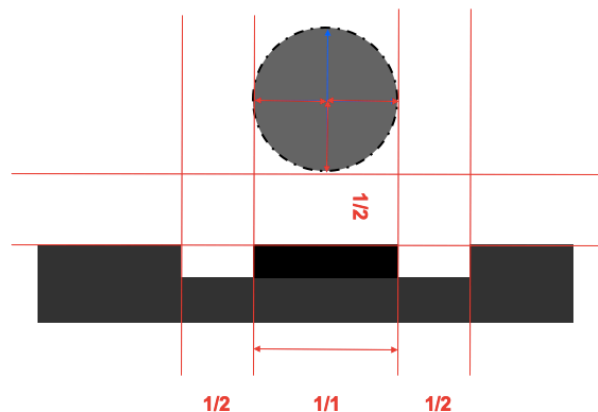

Sighting technique – is the process of following and positioning the pistol sighting elements during lifting and the triggering technique in relation to the target, or better to say, **in achieving correct aiming picture.**

Very often there is debate about several topics regarding the aiming picture. I will try to address some of them and give my point of view, based on various authors and my personal opinion:

- What is the size (width) of the front sight?
 - The simplest thing for the human eye is to recognize the symmetrical relationship of the observed objects. This fact imposes the conclusion from the front sight point of view, that it is easiest to choose its width which is the same as the diameter of the “bull’s eye“.
- What is the size of the white space on both sides of the front sight, in relation to the rear sight?
 - Taking into account the above, the width of the space between the front and rear sights is most noticeable if it represents half the width of the front sight.
- What is the size of the white space between the top of the front sight and bottom of the “bull’s eye“?
 - Simple answer should be – the same as the white space on the side of the front sight i.e., half the size of the front sight width.

Let us elaborate on this statement. There are physiological phenomena called the *framing effect* that will lead us to a different conclusion.

The closer a line extends toward a surrounding frame, the longer it appears.

Theodore Künnapas claimed and showed that the shape of the visual field itself can act as a frame that affects the perceived length of lines in a vertical-horizontal illusion.

This illusion is typically created by having a vertical line rising from the center of a horizontal line of the same length creating an inverted T figure.

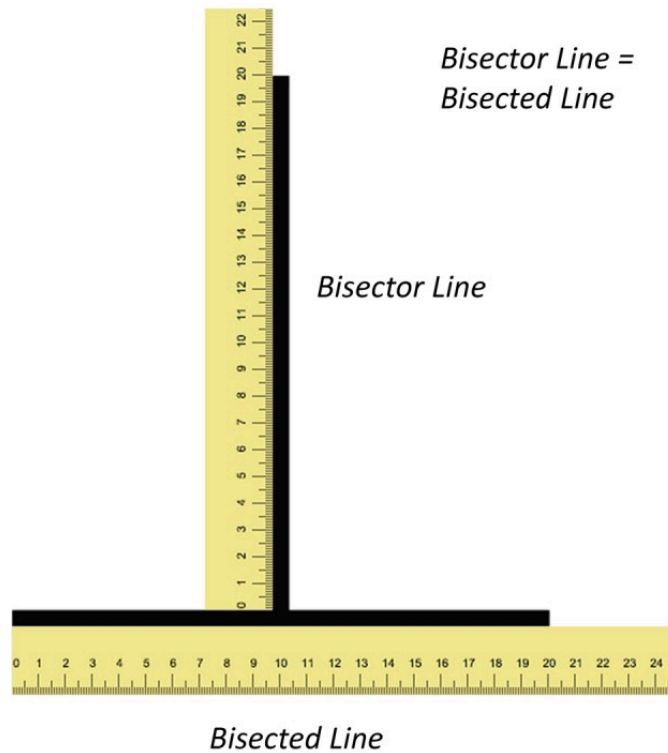

The vertical-horizontal illusion typically consists of a vertical line rising from the center of a horizontal line creating an inverted T figure. Although both lines are of equal length, the vertical line appears longer than the horizontal one. The most prominent theory to explain this illusion was proposed by Künnapas in 1955. This theory, known as the *framing theory*, is based on the principle that the shape of the visual field is more elongated in the horizontal plane as a result of the combined visual fields from each eye merging together. The shape of this visual field under binocular vision creates a framing effect whereby a vertical line appears longer than a horizontal line of the same length. This is because the former is closer to the boundaries of the visual field than the latter.

A team of scientists from Melbourne, Australia (see references below) proved through two experiments, like many other experiments, the accuracy of the Künnapas theory: the visual-field and vertical-horizontal illusion experiments.

“As predicted, the illusion was strongest when the stimulus was presented in either its standard inverted T orientation or when it was rotated 180° compared to other orientations, and in conditions in which the retinal image was more stable, as indexed by eye-tracking. Taken together, we conclude that the results provide support for Teodor Künnapas’ explanation of the vertical-horizontal illusion. “

Department of Psychology and Counselling, School of Psychology and Public Health, La Trobe University, Melbourne, VIC, Australia

Edited by: Michael A. Silver, University of California, Berkeley, USA

Reviewed by: Cheryl Olman, University of Minnesota, USA; Francesca Fortenbaugh, VA Boston Healthcare System, USA

Going back to our statement that: - space between the top of the front sight and bottom of the “bull’s eye” should be the same as the white space on the side of the front sight i.e., half the size of the front sight width – is not quite correct. Actually, the appearance of the distance from the top of the front sight to the bottom of the “bull’s eye” should be the same as the distance between the front sight and rear sight. This effect will be very important in the chapter elaborating “Shooting in different weather conditions“.

The main requirement of the sighting technique in precision shooting is to secure eye focus on the front sight during the final sighting process, for the optimal time. Before describing any sighting technique it is necessary to define the optimal time for the eye to focus on the front sight. During years (decades) of discussions, the findings and techniques have changed. In the late 1960’s it was recommended as 6–8 seconds (Freeman), during the 1970s 5–8 seconds (Yuriev, Standl, Antal & Skanåker), in the 1990’s it was suggested 4–6 seconds (Redhead).

Working for the past 30 years with some of the world’s best pistol shooters, I can state based on my experience and of various tests carried out, that the optimal time needed to focus on the front sight in the final stage of the sighting technique in precision shooting, is just about 3-4

seconds. Anything less than this time is insufficient, and more than 4 seconds is not efficient. Extensive prolonged time in the final aiming area can result in eye fatigue and the development of blind spots that can last up to ten minutes before the eye regains its optimal function (Kalinichenko 1968).

Sure, the most important organ in the sighting and aiming process are the eyes. The light from the target passes over the front and rear sight into the eye where it is diverted by the optical system to the rear of the eye, from where it is translated to a signal that is transported to the optical center in the brain. The information is interpreted and signals are sent to the finger to pull the trigger. This process takes some time, resulting in the shooter always shooting with an “old” aiming picture.

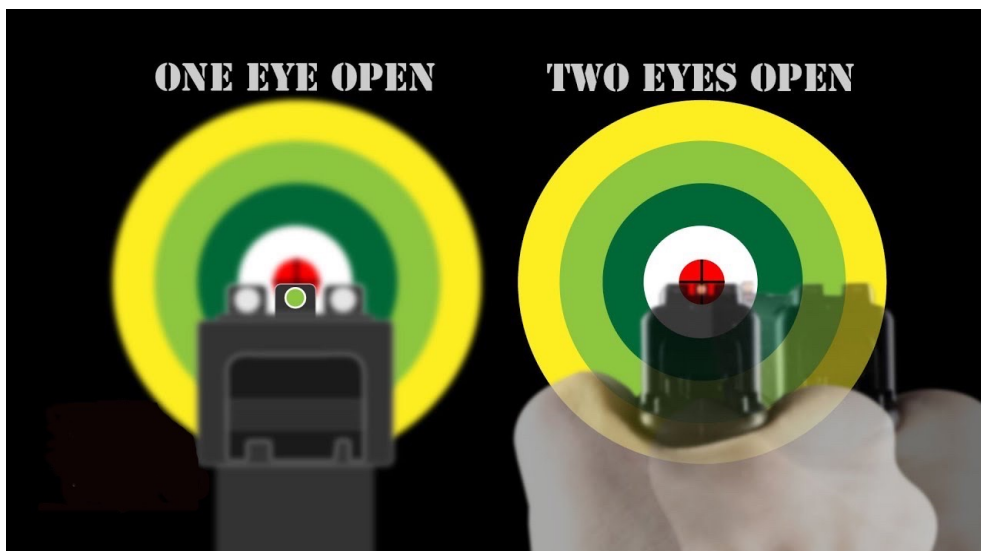

When sighting, the shooter should try to use both his eyes. This recommendation is due to the fact that the eyes work together and the reduced amount of light that the closed eye is causing also has negative effects on the open eye. Kalinichenko reported a 20% reduction in acuity in one eye when closing the other, compared to simply covering the other. For some shooters, it is impossible to keep both eyes open during the sighting process. In this case, it is

recommended to cover the “non-sighting” eye with a white, slightly transparent patch which will enable a sufficient amount of light to reach the covered eye resulting in a higher level of efficiency for the sighting eye. This allows the aiming eye to focus on the sights without a double image, and allows light into both eyes. The irises work in sympathy, so blocking light to the non-shooting eye will cause the shooting eye pupil to enlarge. This affects its depth of field and ability to focus (Redhead, 2005).

Many shooters wear shooting glasses. These correct visions or modify normal vision to improve the ability to focus on the front sight. This can include a lens, filter, iris, eye cover and/or side shield. When using shooting glasses, one has to make sure that the lens is correctly placed, i.e. that the center of the lens is aligned with the eye iris.

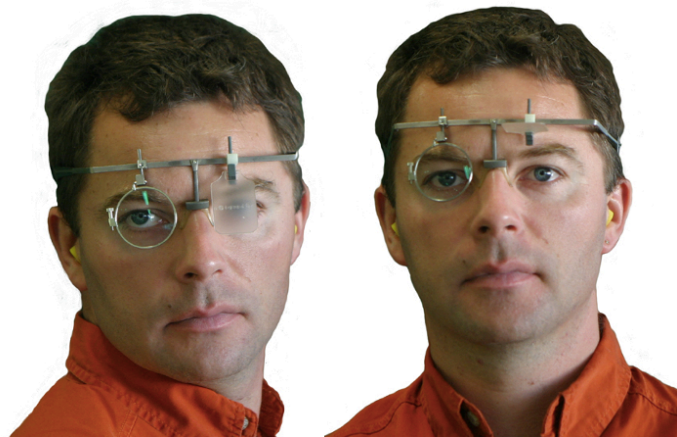

In the following photos, you can see the obvious displacement and corrections needed.

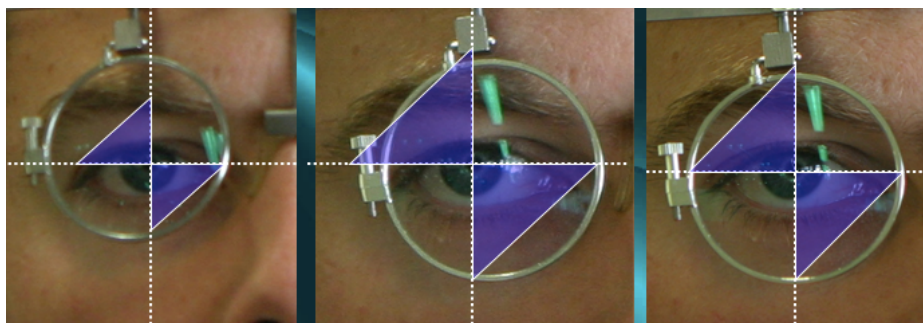

The sighting technique can be divided into four major stages:

- Rough aiming area
- Approaching aiming area
- Fine aiming
- Follow through

ROUGH AIMING AREA

Assuming that the pistol grip is properly fitted and the lifting technique mastered, the sighting technique is started when the pistol arrives in the rough aiming area. Later in this paper, we will see how we coordinate the lifting, sighting, and triggering technique. In precision shooting, the rough aiming area is determined by the lifting technique. In HT this area is above the “bull’s eye”, while in LT it is below the final aiming area. Common characteristics of both situations are that in the rough aiming area, the sighting technique is carried out by a rough alignment of the front and rear sight and is not related to the target in any precise manner. When a satisfactory picture appears, it is time to move to the next stage of the sighting technique.

APPROACHING AIMING AREA

The shooter is carrying out the rough aiming alignment in a vertical line passing through the middle of the target if using HT or just lifting higher if using LT. At this stage, the focus of the eye is still not engaged 100% on the front sight. The reason for this is described in the text above, avoiding eye fatigue. The alignment of the front and the rear sight is more accurate and

almost 90% aligned before coming to the final aiming area. The function of this stage of the sighting technique is to prepare the optimal conditions for the next stage.

FINE AIMING

Entering this phase of the sighting technique, all of the necessary preparations for an optimal final aiming picture is complete. Now is the time to make maximum focus on the front sight within the final aiming area. Above we discussed the optimal time necessary for final aiming. The process developing during this stage is one that we recognize as the automatic firing of the shot. Simply described, the process will function on the following principle:

The lifting technique was performed adequately, providing a minimum arc of movement of the gun. Eye focus is on the front sight and will send a satisfactory picture to the optical center in the brain. The “control center” will forward a “green” light for the rest of the system to perform. The final triggering action will be executed.

DYMANIC

It might seem that there is a radical difference in the sighting technique between the precision and dynamic disciplines, but actually there is not. All the main requirements remain the same, even the technique stages are the same.

Two major differences that must be taken into consideration are the result of the technical rules:

The time limit for the shot/series dictates as we saw in the previous chapter (lifting technique), that the approach to the final aiming area is exclusively done by LT, resulting in approaching the aiming area corresponding with this fact.

The target is black across all its diameter resulting the final aiming area is in the “bull’s eye”, not below as in precision disciplines. Those facts will somehow dictate a few minor adjustments in the sighting technique. In Sport Pistol Rapid Stage, approaching the aiming area

will be dictated by the lifting technique applied i.e., FST or FT. In the first scenario, the rough aiming area will be located in the area of the lower edge or below the target, and the final aiming area is in the middle of the target. In the second scenario, approaching the aiming area will be identical to the final aiming area. I am not trying to suggest a combination, but with the latter we can see some of the possibilities.

A great difference is in the fact that the eye must focus on the black surface of the front sight, while pointed against the black background of the target. In precision shooting, this issue is easier to manage because of the contrast produced by the white background of the target. On the other hand, the diameter of the “rapid” ten is 100% bigger than the “precision” ten. This fact will, to a great extent, compensate for minor mistakes in the front sight focus during the rapid stage without seriously diminishing the result. This does not mean that the focus on the front sight is not important. It is of essential value to teach the shooter to focus on it.

Rapid Fire Pistol's first target is handled in the same fashion as the Sport Pistol Rapid Stage sighting technique. Previously, while describing the lifting technique, we mentioned the necessity to deal with the horizontal movement to targets 2, 3, 4 & 5. This fact produces a requirement that a sighting technique has to be adopted for this sequence.

Basically, we can differentiate two well-know “horizontal” sighting techniques:

- Permanent follow of the front sight technique (PT)
- Moving the focus of the eye to the next target (advancing), before moving pistol (AT)

The first sighting technique has the benefit of never leaving the focus from the front sight and securing the certainty of the alignments of the sighting elements at times during rotation across the targets. The disadvantage of this technique is that it can produce eye fatigue and/or

disorientation when attempting to coordinate the middle of the next target with the pistol sighting elements.

The second technique has a “system of guiding” benefit i.e., visually locating the next point of stop that the shooter has to make. The great disadvantage will be the focus tilting from front sight to the next target and back to the front sight.

Self-evaluating question

Define aiming picture.

Define the sighting technique.

Explain framing theory.

Describe sighting techniques in precision disciplines.

Describe sighting techniques in dynamic disciplines.

4. TRIGGERING TECHNIQUE

In my humble opinion, triggering is the technical element that plays the most important role in performing the correct shot.

The proper triggering technique can be defined as uniformed, progressive pressure on the trigger shoe, without interfering with aiming stability. The proper triggering technique must not compromise the minimum arc of pistol movement, whether it is a displacement that is reflected in the position of the front sight or displacements in the area of the rear sight. The way the triggering technique is performed depends on the qualitative level of the shooter. Beginners tend to pull the trigger rapidly, which is the result of "image hunting", without feeling or knowledge of the triggering technique. The top shooter pulls the trigger as a result of the "correct image" with the maximum sense of performance and a highly trained triggering technique.

For an easier description and explanation of the various triggering techniques, we need to know that the trigger mechanisms, used for both the precision and the dynamic disciplines, are triggers with acceleration (mechanical or electronic). It means that there are two stages in its functioning; first leg (FL) and second leg (SL), divided by a trigger stop (TS). Such a mechanical construction gives the possibility for individuals to make their preferred adjustment and deliver a triggering technique in a personal and unique manner.

The trigger function will produce three technical requirements:

- Pulling the first leg
- Trigger stop
- Pulling the second leg

Regardless of the personal preference of the trigger setting or technique, the pressure on the second stage is very important. The pistol must be stable and aligned with the center of the final aiming zone before and during the shot. In order to meet these conditions, the pressure of the finger on the trigger must be parallel to the axis of the barrel, and at the same time it should build an angle of 90 degrees with it. To achieve this, it is necessary to have a well-adjusted grip as well as the position of the trigger shoe.

There are three methods of pulling the trigger:

1. progressive and continuous pressure,
2. pressure with preparation – gradual triggering
3. triggering in phase – pulsating triggering

The first technique is most often used and is recommended when working with beginners. It is also used by shooters who have a stable hold in the final aiming area. The pressure is continuous during the second trigger action. The finger pulls slowly, and continues after releasing the

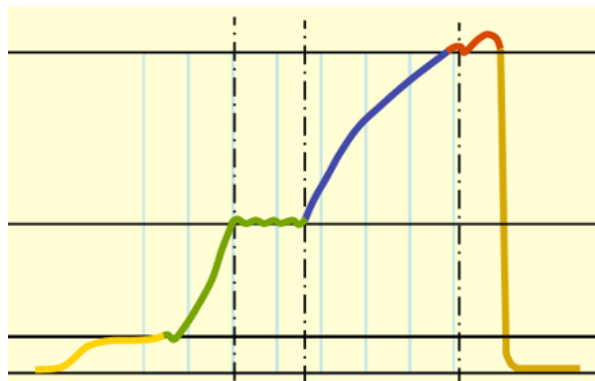

shot. This action largely depends on the aiming picture. The downside is that the shooter cannot be sure when the shot goes off and this fact can affect coordination with aiming.

The second technique is called "pressure with preparation". It consists of pulling the trigger between the first and second leg with more pressure than the first technique, but without firing a shot. This is the most used technique among world top class shooters. The shooter is developing a very fine sensation while executing triggering action, providing the possibility of conscious correction before firing a shot.

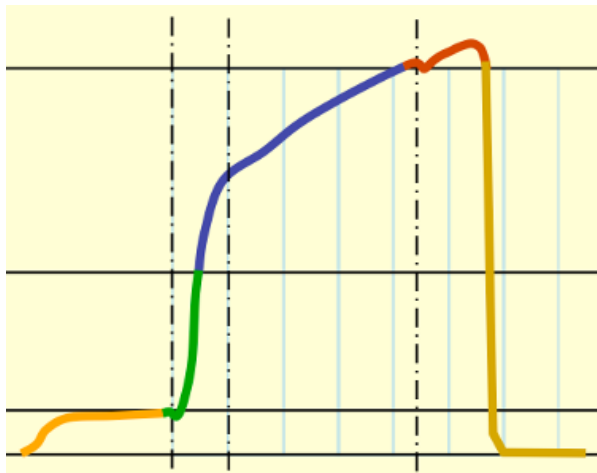

This method allows shooting in any state of stability. It is fast and efficient. It is an economic technique that is very good for superbly built shooters in competitive conditions. The shooter who uses this technique must be very careful because in conditions of increased and uncontrolled

stress, the trigger can be pulled too fast, which is also the biggest disadvantage of this technique.

The third technique "phase triggering", consists of pulling the trigger in the second stage by short progressive pulls, followed by release and another pull movement. The graphical representation of this technique resembles an ECG curve, so it is also called a pulsating technique.

This technique is a good way to learn the trigger sensation, at the same time allowing for improving coordination between aiming and triggering. A great benefit of this technique is in the preventive effect of "blocking the trigger technique".

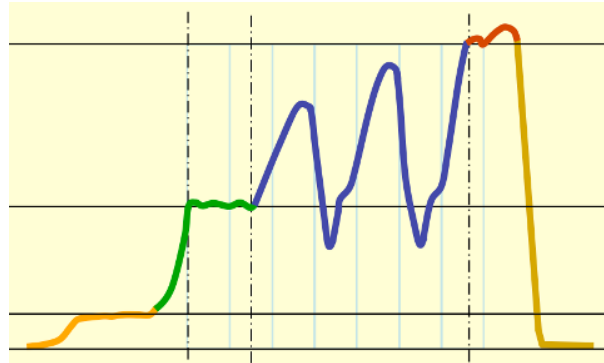

For improving the conscious activity of triggering technique, this method of triggering is used in rifle disciplines, but is not recommended for pistols except in the training process.

The general recommendation would be to learn all the techniques in order to improve the ability of the trigger sensation, but it is very important that the shooter and the coach choose the best combination. The triggering technique should be such as to allow the shooter to perform it under any circumstances and conditions. The shooting technique must be brought to automatism, to be repeatable and at the same time effective, which is triggered by the correct aiming image.

PRECISION

The question arising is where to deliver the first trigger technique sequence. The answer to this question will be largely determined by the lifting and the sighting technique used. In HT, the

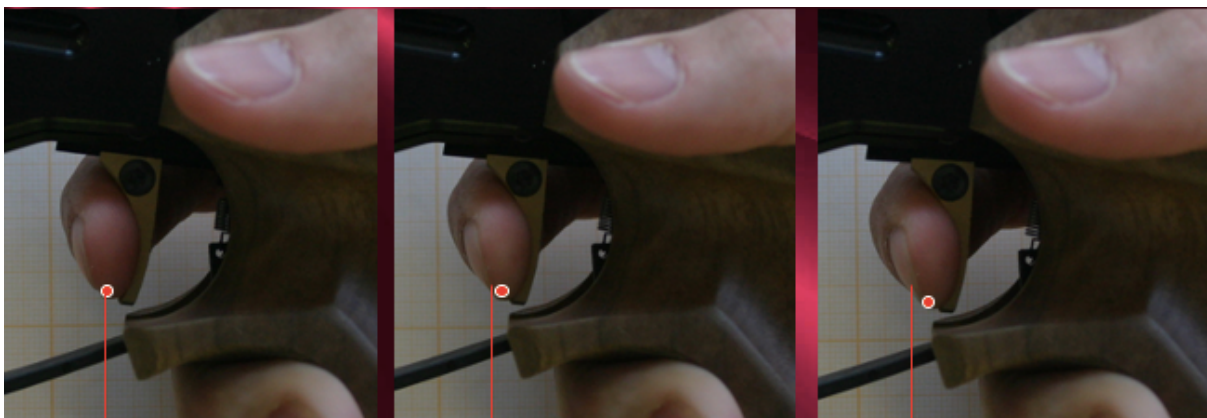

first leg can be pulled on the way above the “bull’s eye”, when reaching the highest lifting point or when coming into the rough aiming area. My suggestion is that it should be done in the latter. It will correspond with the start of the coordination of all three techniques (lifting-sighting-triggering). Applying this model will mean that the second sequence (trigger stop) is completed just before the beginning of the descent through the “bull’s eye”. The second leg delivery begins in the final aiming area and is completed in the time frame described above.

LT is somewhat different due to its nature. The first leg and trigger stop are completed just before entering the final aiming area, and the second leg delivery is identical as in the HT model.

Trigger technique will also be determined by the trigger weight distribution. AP and SP could be generally observed on the same principle, i.e. the first leg will have 70% of the trigger weight distribution and the second leg 30%. It will mean that the AP first leg will be 350gr (SP 700gr) and the second leg 150gr (SP 300gr). For fairness and respect, a few words on Free Pistol triggering where the situation is somewhat different. Many shooters use trigger mechanisms without an accelerator, but the situation has significantly changed in the past few years with weapon manufacturer’s development of the two-stage trigger. Still, trigger weight is significantly lower and very much individually adjusted. Training and speaking with some of the greatest FP shooters of the past time, I can recommend that the trigger weight should not be set below 70gr. Such an adjustment provides a comfortable trigger finger contact with the trigger shoe enabling a correct triggering action, yet leaving a light trigger weight.

DYNAMIC

As in the lifting and sighting technique, the trigger technique in dynamic disciplines is with LT characteristics. It is commonly adopted that the first leg and trigger stop are completed in the ready position in SP Rapid Stage. As the trigger time available is relatively short, method number two “pressure with preparation” is the method of choice for most top class shooters. In cases when the shooter uses the FT lifting technique, the first triggering method may be used, but this is not something that we meet very often. When using method number two, and taking into consideration the fact that the second leg weight distribution is significantly high, provides a relatively safe lift (without accidental firing) and enabling the optimal condition for completion of the second leg technique delivery. In RFP the situation is different as the triggering mechanism requires the total release of the trigger pressure after firing the shot in order to re-engage the trigger mechanism for the next shot. A very short time interval between shots dictates the need for the shooter to make a personal choice of weight distribution between the first stage and the second stage of the trigger. This choice is based on individual abilities (fx. reaction time) and characteristics of the pistol model/type (mechanical or electronic trigger mechanism). As a consequence of this selection, the shooter will also choose one of the three techniques that is most compatible with his abilities and trigger weight setup.

Self-evaluating question

Define trigger weight distribution

in Air Pistol

in Sport Pistol and Rapid Fire Pistol

Describe triggering techniques in precision disciplines.

Describe triggering techniques in dynamic disciplines.

5. FOLLOW THROUGH

When the shot has been released, the bullet will need some time to leave the barrel. This time is measured in milliseconds, depending on the type of the gun and ammunition used, making it necessary to maintain the pistol in the same manner as during the final aiming stage. Focus on the front sight has to remain for at least one additional second after the shot has been fired. This will ensure that the pistol is not moved too soon from the optimal position and will provide the shooter with priceless feedback on the intellectual level, as well as the “muscle memory” level. It is important to emphasize that follow through is not just a part of the sighting technique, but it is also a part of mental control and endurance. If one should try to make a definition for follow through it should sound something like this: “Follow through represents mental and physical state after the shot has been fired, before impact of the bullet/pellet with the target and additional time after impact.” Follow through technique does not exclusively belong to shooting sport.



We can find this technique in many other sports as an essential part of the overall technical execution of the “shot”, like in tennis, basketball, golf etc.



A typical mistake for beginners and often for experienced shooters, is reflected in the lack of the follow through technique due to the desire to see the value of the achieved hit on the screen/target as soon as possible. Such behaviour leads to the conclusion that the mental element of performing the correct shot was completely absent. Of course, in most cases, the desired outcome will be absent.

It is necessary to keep follow through on all aspects - aiming picture, index finger on the trigger, gripping force, muscle tension, breathing pause, balance, mental state, etc.

Correct execution of follow through gives the possibility of instant analysis, as well as a possible response to the situation that occurred during the firing of the shot. What happened, how it happened and why it happened are the most common questions, and the answers can be found instantly. Follow through can result in the prevention of error recurrence, which results in maintaining a more stable level of performance. The golden rule of improving performance level is to reduce the number of mistakes an athlete could make. Positive feedback of the correct shot at the same time raises self-confidence and motivation to perform what was trained. Follow through is not only a necessary part of the overall technique but is, at the same time, a teacher.

5. SHOOTING IN DIFFERENT WEATHER CONDITIONS

When we talk about shooting in different weather conditions, the most common association that comes to mind is the influence of wind and light. Of course, these are not the only weather conditions that can affect a shooter's performance. The influence of mirage, temperature, humidity and altitude must also be taken into account.

WIND CONDITIONS

One of the major problems and challenges for 25m events is wind. To manage the impact of the wind it is necessary to understand the basic influence of the wind on pistol shooting. Wind movement has to be observed for direction, strength and consistency (gusts). The longer the

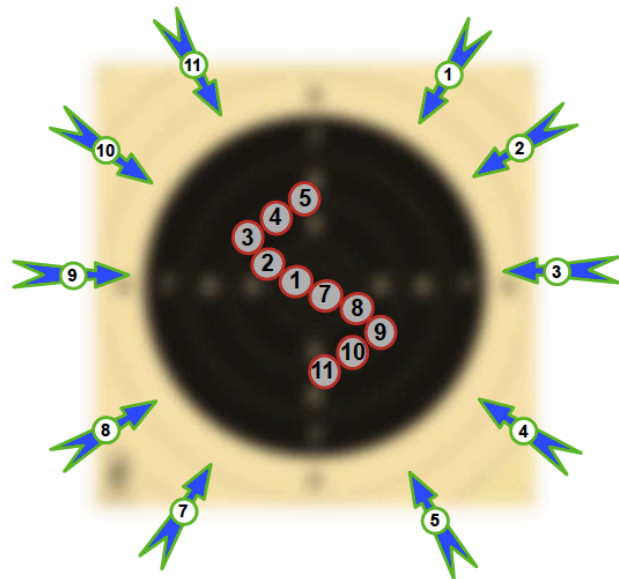

distance the greater the influence of the wind. The basic reason is that the velocity of the bullet drops when the flight time increases. There are some alterations on hit points due to the wind direction. As the wind flags are not existing on 25m open ranges, one has to use any possible indicator for detecting the direction and strength of the wind on the shooting range. It could be grass, dust, clothes, blinders between shooting stands, or anything that wind can move. For theoretical reasons we can explain how the wind is affecting the trajectory of the bullet. A wind that blows from the sides can deflect the bullets in horizontal, but also vertical directions,

because of its rotation in a clockwise mode. For instance, a right wind will push the bullet to the left side and high, and left wind will pull it to the right and down. The figure shows the impact of wind on the result of the shot.

The real problem with the influence of wind in the 25m disciplines is reflected in its effect that causes the stability of the shooter. The impact of wind is mostly manifested by its negative effect on the body and/or right arm, thus diminishing the stability of the shooter and increasing the arc of movement. Despite the lack of indication flags, the shooter must be familiar with the conditions on the shooting range and shooting line, since the influence and effects of wind depends on its power and direction, the firing line number, etc. Those observations have to be done during the official training or PET. The wind will always have its characteristics, intensity, and dynamics, which can give a possible tactical solution for the shooter.

The special importance of choosing a tactical solution is needed in the precision part of the SP discipline. Five minutes, as long as one series lasts, is quite enough time to implement the chosen tactic. It mainly consists of predicting wind gusts, followed by a period of reduced intensity or complete absence of wind, when the shooter delivers a shot. In order to learn and master this tactical solution, it is necessary to use windy conditions for the training process as often as possible. I have seen some indoor shooting ranges where equipment is installed to produce artificial wind conditions. Surprisingly, it was not a costly investment comparing to the achieved effect.

Dynamic disciplines - SP Rapid Stage and RFP, are demanding a different approach in dealing with windy conditions. As there are no possibilities for tactical prolongation of the time for the shot in these disciplines, it is necessary to find the best comparative solutions. Position adaptation, mainly with an increased activity of muscle in terms of additional position stability, is one of the most commonly used methods.

LIGHT CONDITIONS

Very often in the literature, the influence of light is neglected when we are talking about indoor shooting ranges, whether we are talking about 10m shooting ranges or final hall ranges.

It is a fact that shooting ranges respect the technical norms of lighting, but it is also a fact that the lighting varies from shooting range to shooting range. The reasons can be different, starting from the allowed tolerance of illumination, the height of the ceiling, the colors that dominate the interior of the shooting range, etc. All these factors affect the shooter's individual perception of lighting. Therefore, it is important that the shooter needs to study the light conditions on the shooting range during official training and PET. These training times serve to set the sighting elements, to enable hits in the center of the target. The next step is to adjust the sight elements in such a way that allows the shooter to focus clearly on the front sight without tiring the eye. This can be achieved by widening or narrowing the width of the rear sight. Another way to improve the clarity of the focus on the front sight and make it easier to aim is by using one of the available glass filters. Regarding the final part of the match, the conditions for adjustment are significantly different. Adaptation to the light conditions can be achieved, to some extent, by visiting the final hall during the finals in some other disciplines.

When speaking about light conditions on 25m range, on a sunny day shooting in the morning and in the afternoon may show alterations. The angle at which the sun's rays fall will significantly affect the grouping of hits on the targets. The clarity of focus on the front sight will also depend on this angle. Also, it will determine the amount of light between the front sight and the rear sight. Regardless of any weather conditions, it is recommended that the front sight be blackened using one of the known products. Conventionally, in the intensive lights we must apply a dark filter such as gray. In weak light conditions, a bright filter such as yellow are much better and preferable. Yellow filters are the filters of choice when shooting in weather

conditions when light is dispersed by drops of rain, or by dusty particles when shooting on shooting ranges that suffer lack of grass or are situated nearby dusty soil.

In interchangeable weather conditions, when clouds are moving across sky covering and/or uncovering the sun light, it is necessary to engage one of the two major tactical options:

- Wait for “default light” – can possibly be done in precision stage of SP
- Rear sight adjustment – by clicking predefined number of clicks based on previous trained experience – can be applied in both SP and RFP disciplines

Understanding how the amount of light rays affects the formation of hits on the target is vital. Theodore Künnapas's theory (see p.17) can help us find the right solution. Let us take the example of having "normal light" as a condition, where shots are grouped in the middle of the target. If the intensity of the light increases, the bright area between the front sight and the "bull's eye" will appear bigger, higher. This appearance will result in, as a consequence, a tendency for the shooter to "correct" the white gap by raising the gun. The final outcome will be high shots grouping on the target. Opposite, when the intensity of the light is decreasing, for example by cloud coverage, the gap between the front sight and bottom of the "bull's eye" will appear less. The consequence will be that the shooter is lowering the gun in an attempt to restore a "normal" white gap resulting in low shots grouping on the target. A simple conclusion will lead us to a simple definition:

When the Sun is up - the shot is up. When the Sun is down - the shot is down.

MIRAGE

Mirage is another variant of weather conditions that should be taken into account. In any case, this natural effect has a significant impact on the 50m discipline. At 25m shooting ranges its effect is almost insignificant, but for the sake of general knowledge, we will say a few words about this weather condition.

During sunny days, due to the increase in the outside temperature, the soil warms up more and more. As a result, the layer of air just above the ground heats up. Due to the increase in its temperature, this layer of air begins to expand and rises up as lighter air. At the same time, the cooler air above this layer descends towards the ground. The alternation of this process of heating the air causes the air to flicker and this natural phenomenon is called a mirage.

Mirage in combination with windy conditions can further complicate the conditions on the shooting range, resulting in more significant offset of the shot group from the center of the target. The necessary corrections to be made in such weather conditions are exclusively learned during the training process in the mentioned weather conditions, so it all depends on the experience of the shooter.

TEMPERATURE

The influence of temperature can have a dual effect - on the body of the shooters, as well as on the functionality of the weapon and the characteristics of the ammunition. Whether we are talking about low or high temperatures, the shooter must be fully prepared during the training process in order to adequately take the necessary measures. In these papers, we will not look in more detail at the necessary measures concerning the action of the shooter, because such weather conditions are "normal" during a lifetime and we all know what to do. We will look, as an example, at the influence of the outside temperature on the right hand of the shooter. Of course, it is well known that in colder weather conditions the hand will shrink, while in warmer conditions it will swell. In any case, this will result in the need for additional adjustment of the grip setup so that holding the pistol and pulling the trigger would be performed as in "normal weather conditions".

Regarding the influence of temperature on the functionality of the weapon, it is necessary to know that the structural materials of the weapon behave differently in different temperature conditions. In colder weather the materials shrink, while at the higher outdoor temperature they expand. These changes in the structural density of the materials from which the different parts of the pistol are made, will inevitably lead to different functional characteristics of the weapon. For example, there may be an expansion or contraction of the weapon barrel diameter, which will inevitably reflect the accuracy of the grouping of the shots. To overcome this problem, it is necessary to have ammunition that has been tested for different weather conditions. More on this topic will be in the section "ammunition testing". Changing the outside temperature will also affect the trigger adjustment characteristics, which in turn means that additional trigger adjustment is required.

HUMIDITY

Humidity, similar to different temperature conditions, affects both the shooter and the functionality of the weapon and the characteristics of the ammunition. Without much need to say how humidity affects the human body, it is sufficient to say that athletes must take all necessary measures to function as stable as possible in conditions of increased or decreased humidity. At the same time, it is necessary to pay additional attention to the condition of the weapon in extreme changes of humidity. Particular attention must be paid to the selection and preservation of ammunition and its characteristics.

ALTITUDE

Altitude is another in a series of weather condition aspects that can affect a shooter during a match. Of course, as with the previously described weather conditions, the shooter, weapon

and ammunition can be affected by altitude. This is especially pronounced when competitions take place at higher altitudes, where the air density is diluted. Eventually, a smaller amount of oxygen will affect the shooter, while a reduced air density will affect the ballistic behavior of the bullet. One of the solutions, in terms of setting the correct tactical response to such conditions, is to conduct training camps in similar competition circumstances.

Conclusion:

All the above-mentioned weather conditions should be analyzed from the aspect of the impact on the athlete, as well as the impact on weapons and ammunition. In a brief review I have mentioned some of the examples, but a deeper study of these circumstances needs to be considered. All the necessary adaptation measures which concern the athlete, will need to be analyzed and solutions made with experts in the field of medicine, physiology and physical training. The technical aspects of weapons and ammunition would be best handled with weapons and ballistics experts.

Self-evaluating question

Describe the impact of various weather conditions on pistol shooting:

wind

light

mirage

temperature

humidity

altitude

5. WEAPON MAINTENANCE

Every type of precision mechanical and electronic equipment needs regular inspection, service and maintenance. Today's pistols represent just that type of equipment - a mechanical and sophisticated electronic machine. For the precise functioning of the pistol, it is necessary to undertake a series of detailed inspections and maintenance. Ideally, each team (local or national), would have a professionally trained and equipped gunsmith. Unfortunately, this is not a reality in our sport; on the contrary, it is a rarity. Very often shooters are the ones responsible for checking and basic servicing of pistols. Maintenance is performed through the following steps:

- Daily check of the correct functionality of the weapon should be done by visual and functional inspection. The condition of the grip, its firmness, as well as the firmness of the front sight is checked. Special attention should be paid to the condition of the rear sight as it is a complex assembly of very fine mechanics. The condition and functionality of the slide and magazine should also be reviewed for SP and RFP.
- Daily maintenance and cleaning of weapons is a matter of necessity and discipline, rather than free will. Cleaning an air gun barrel, since it is not using explosives, is simpler than cleaning SP and RFP. In any case, barrel cleaning is still necessary due to the accumulation of lead deposits, dust, dirt and moisture from the air. It is possible to pull through cotton threads with the help of a nylon-string, or by shooting the felt pellets. Caution is needed on this occasion because firing felt pellets can still cause injuries. The compressed air pressure in the air cylinder is very high - 200, so it should be handled with maximum care.

- During the firing from the SP & RFP, due to the explosion of gunpowder charge, burnt material, as well as the remains of gunpowder, particles are accumulating in the barrel. Burnt debris and dirt are blown on the trigger mechanism as well as on the surfaces of the sliding elements of the gun. Those deposits are retained in the barrel and fill the rifling grooves. Moisture from the air causes oxidation and micro-damage to metal parts, as well as moisture and salt from sweat from the hands. It is very important to clean and protect weapons every day. The barrel can be cleaned with a plasticized rod with a rod guide to prevent damage, or by pulling off the cotton fabric with a nylon rope. A dry patch is used first, followed by a solvent patch. It is necessary to leave the solvent for a shorter period of time to soak and decompose the deposits, and then clean again with a dry patch. If done regularly, the need for brushing is reduced. If there are larger deposits, the use of a brass brush is mandatory. The frequency of cleaning and lubrication will partly depend on how dirty the ammunition is and how many shots are fired. In any case, during the training process it would be desirable to clean the weapon after each training unit. When it comes to competition, the pistol is thoroughly cleaned before the official training. Brushing of the barrel and moving parts is done after PET without applying oil, so as not to decrease the accuracy of the pistol. It is necessary to remove the oil film from the inside of the pipe before use, to avoid further damage to the pipe due to oil burning.

Moving parts must be clean and properly lubricated to ensure consistent weapon functionality and minimize parts wear. The triggers must be blown out with compressed air or cleaned with a soft brush so as not to build up dirt deposits in the dried oil thus disturbing precision of the trigger mechanism. When cleaning the pistol, all screws and fasteners should be inspected for safety and tightened before the next use.

The gun should be stored in dry conditions, to avoid unnecessary condensation. The outer parts of the gun must be cleaned and coated with a suitable oil during storage.

- Annual servicing of weapons is mandatory. All gun parts should be inspected. Worn and/or damaged parts should be replaced. When we talk about AP, air cylinders must be opened and cleaned of corrosion caused by condensation of unclean compressed air. The parts of the air cylinder valve should also be serviced. One should bear in mind that air cylinders have a legal life span of 10 years - after that time must be replaced. All moving parts of the pistol, AP, SP, RFP must be thoroughly inspected and replaced with new ones, if necessary. Special attention should be paid to the condition and servicing of the trigger mechanism, both mechanical and electronic components, if the gun has an electronic trigger. All rubber O-rings should be replaced, as well as all springs. It is necessary to change the firing pin and springs in the magazine. The condition of the rear sight should be inspected and worn or damaged parts replaced, if necessary. In the case of an air pistol, it is necessary to check the speed of the pellets at the end of the service, as well as to fine-tune the trigger mechanism on all types of the pistols.
- Weapons reparations due to malfunctioning or damage
The normal routine for each shooter is to have a set of spare parts that can be replaced during training or competition as needed, when a gunsmith is not available. The spare parts set for the Air Pistol consists of a spare battery for the trigger mechanism, a spare trigger mechanism, spare air cylinder, spare front and rear sight, a spare grip. For SP and RFP, beside front and rear sight, grip and trigger mechanism, it is necessary to have a spare magazine, firing pin, as well as a set of spare slide springs. Of course, in addition to spare parts, it is necessary to have the appropriate set of tools for reparation, including equipment for measuring the speed of pellets/bullets.

1. HOW TO AIM AND SIGHT

In the theoretical part of this paper, the difference between aiming and sighting was elaborated and defined. In this chapter, as we are discussing practical applications, we will try to find out how these two segments are cooperating during the actual shooting process. An example can be any of the various pistol disciplines, but in our case we will use RFP discipline, while selecting one of the available sighting techniques.

The process of aiming can be selected through two choices. The focus of the eye is on the target while the sighting elements are blurred, or the focus of the eye is on the front sight and the target is in the blurred part of the field of vision. Of course, as has been said before, the second choice is the correct one. Therefore, the shooter engages the focus of the eye to the front sight, from the very beginning of the "ready position". Performing the lifting technique is done without dropping the front sight from the focus of the eye. This sighting technique results in the movement of the head, which adapts to the lifting technique throughout the entire process. Such coordination technique has to be developed on the premises of Pavlov reflex i.e. reflex triggered with certain conditions.

Russian scientist Ivan Pavlov (Nobel Prize 1904) in 1897, established the theory of respondent conditioning, by experimenting with a dog's saliva glandules response to a bell ringing when fed.

“Classical conditioning (also known as **Pavlovian** or **respondent conditioning**) refers to a learning procedure in which a biologically potent stimulus (e.g. food) is paired with a previously neutral stimulus (e.g. a bell). It also refers to the learning process that results from

this pairing, through which the neutral stimulus comes to elicit a response (e.g. salivation) that is usually similar to the one elicited by the potent stimulus.”

In our example, the conditioned reflex should appear for two segments of the coordination technique. The first reflex is associated with the green light appearing as a stimulus to which the lifting technique responds. The second reflex occurs when a triggering action is activated on the correct aiming picture stimulus.

To bring the coordination technique to the highest possible level, it is necessary to develop instrumental conditioning. Operant conditioning (also called instrumental conditioning) is a method through which the strength of voluntary behavior is modified by reinforcement. The development of coordination techniques should also be developed through learning methodology, reinforcement/repetition (Skinner).

The progress made in the fields of physiology of the neurosciences and equipment, will modify the stereotype approach to aiming/sighting technique.

Progress in the knowledge of eye physiology made it possible to widen the fields of investigation in the field of peripheral and focused vision.

The eyes have several functions and are sending information to the brain which one did not suspect. The functions known were summarized, simply in vision and “directing eye”.

It is known now that the eye has other capacities that can be different and/or complementary from one eye to the other: directing eye, acuity, balance, color perception, contrast, intensity, relief, etc. It was highlighted in 2012, the possibility of having a “postural” eye not only in the management of balance but also in the management of movement.

The retina is composed of light-sensitive cells known as rods and cones. The human eye contains about 125 million rods, which are necessary for seeing in dim light. Cones, on the other hand, function best in bright light. There are between 6 and 7 million cones in the eye and they are essential for receiving a sharp accurate image and for distinguishing colors. The

retina works much in the same way as the film in a camera. The rods and cones are more numerous in the fovea posterior half of the inner face of the ocular sphere. The vision is at maximum within the foveal retina and does not exceed 2° amplitude. From 3° of the point of fixing it become less powerful (150 000 receivers with mm²). The peripheral vision starts from 5° (60000 receivers), and the peripheral vision is necessary to obtain an optimal balance.

The assessment established between the international shooters and the national shooters shows that the "Sutters strategy of movement" is a need for progressing performance. **It is thus necessary to set up a strategy in developing an oculomotor function.**

The movement of the eye and the weapon are independent (Sutter). With the national shooters, movement of the eye and the weapon are synchronous or a bit different. This behavior is identical despite the speed of movement. The strategy of **oculomotor function** independence makes it possible to reduce to the minimum duration of the eye movement making it possible to increase the stabilization time preceding the triggering. The more the visual fixation (anchoring) the more it is effective. The increase in the stabilization phase provides better precision. This report implies a necessary application in the visual strategy of the national shooters if wanting to progress to an international elite level.

Place of anchoring

We already spoke about the importance of approaching the position in a correct manner. Whether the position is obtained correctly or not will greatly determine the success or the failure of the shot. Through training, the shooter is developing a memory of position. The main focus is to create a memory of a position according to the goal. This goal can only be the target and more particularly with the acceptable zone of comfort, in which anchoring is carried out.

In the perception of the brain, the oculomotor function is essential because it takes part in the postural tonic activity, the movement and the precision in the execution of the movement. The

visual information data acquisition must be optimized to support its treatment (analysis) by the brain which gives the most adapted response to the active phase, triggering execution.

To correctly build a memory of position in correlation with visual anchoring, it is thus the essential element to allow a correct active phase. It can only be carried out in the following order:

- visual anchoring on the target (rough aiming area)
- approaching position together with visual anchoring on the target

The national shooters need a reference mark and in 90% of the cases, they are looking at their feet! It can be sensitive in the field perception of the position but not correlated with the real goal: the target. **"A cheetah when hunting does not look at its feet but focuses its aiming on the target: the gazelle".**

During RFP, everything is organized according to visual anchoring.

The choice of the lifting technique depends on the shooter's choice, one between the two classic lifting techniques, but the common point is in the zone of selected visual anchoring.

The first stimulus is the target's green light. In both lifting techniques, it triggers the process of lifting. During this process, only the eye and the unit arm/weapon moves. The eye passes from initial focusing (goal) to focusing on the front sight. This is happening through the transition of the peripheral view, during the fast lifting of the arm, to focusing on the front sight during the deceleration phase. Immediately after firing the shot starts phase two of the "Sutters strategy of the movement".

Conclusion:

Before choosing and designing appropriate aiming and sighting techniques, both coach and shooter should be aware of the eye functionality, as well as a mechanism, build-up, and functionality of the desired reflexes.

2. APPROACHING CENTER OF THE TARGET

This chapter will mainly deal with the coordination and implementation of the previously established facts from topics “Sighting Technique”, “Lifting Technique”, “How to Aim and Sight”, in combination with breathing techniques. All four techniques determine how to approach the center of the target. Considering the number of disciplines, various techniques and their different modalities, it would be too lengthy to elaborate on all of them. Here we will elaborate on one model as an example, which can be used as a basic principle to modify for specific individual combinations. Our example is describing basic precision discipline.

Before we talk about breathing techniques, let us first see some facts about the physiology of breathing. The average number of breathing cycles is 15 per minute which means that one breathing cycle (inhale and exhale) is 4 seconds. Humans breathe without thinking because the body does it automatically. Some conditions can change breathing patterns and make a person feel short of breath, anxious, or ready to faint. When this happens, it is called hyperventilation, or over-breathing. That is when the athlete inhales much deeper and takes a breath much faster than normal. In sport, hyperventilation can be the result of volunteer activity (when a shooter attempts to raise the level of oxygen), nervousness, anxiety, or stress. Very often we find all of these in our sport.

Normally, we breathe in oxygen and breathe out carbon dioxide. “Carbon dioxide is a byproduct of the energy-generating chemical reactions occurring within the cells of the body. Carbon dioxide produced by these chemical reactions within the cells of the body diffuses into the blood which transports it into the lungs where it is eliminated from the body in exhaled air. But carbon dioxide is not just an inert waste product. It is also a vital component in the

maintenance of the chemical environment of the body because it also regulates the acidity of the blood, as well as other fluids outside and inside each cell of the body.

In practical terms, all carbon dioxide is eliminated from the body as a gas in exhaled air. When the volumes of air breathed into and out of the lungs increases above what is normal, more carbon dioxide than normal is eliminated from the body. This lowers the pressure of carbon dioxide within the body, whereby carbonic acid changes back into water and carbon dioxide, eventually resulting in a new equilibrium between bicarbonate ion and carbon dioxide. But this spontaneous chemical reaction whereby carbonic acid returns to water and carbon dioxide is not as rapid as the speed with which carbon dioxide is removed from the body by hyperventilation. So when carbon dioxide pressure in the body is suddenly lowered relative to the bicarbonate concentration, the pH increases above normal because the bicarbonate concentration does not decrease as rapidly. The condition where the pH of the body is increased above normal is called “alkalosis”, and all the body fluids and cells become more alkaline than normal. This effect lies at the basis of the mental effects of hyperventilation.

Kety and Schmidt found that clouding of consciousness and unconsciousness became increasingly likely when the carbon dioxide pressure fell below 30 mmHg (Kety 1946). This threshold was subsequently confirmed by Rafferty in 1992, who also found that all people developed neurological symptoms due to hyperventilation at a carbon dioxide pressure of 20 mmHg (Rafferty 1992).

The mental effects of hyperventilation are very mixed. People with hyperventilation commonly describe symptoms such as disturbed mentation, impaired concentration, poor memory, and hallucinations. Feelings of depersonalization are also common, where hyperventilating persons describe sensations of unreality or feeling everything is confused and dream-like. Visual experiences such as blurred vision, tunnel vision, flashing lights, and seeing double also occur (Evans 2005, Lum 1987, Perkin 1986).”

All of the above leads to a simple conclusion. The breathing technique must be in line with the framework of normal, natural breathing, without hyperventilation. When we talk about breathing techniques during a single shot cycle, we can differentiate the breathing technique during the lifting technique and aiming technique.

When performing LT, the gun is raised directly to the final aiming area and the breathing technique is done with a single “action” – inhaling and stop breathing while aiming and releasing the shot.

[See the attached video – “SP 1 breathing”.](#)

Usually, this breathing technique is finding its place in dynamic disciplines, but can be applied in precision discipline when the shooter is running out of time (end of the match or during final shooting).

If the shooter is using HT for raising the pistol, one of the two breathing techniques can be chosen, depending on the sighting technique.

A single breathing technique is applied when lifting the pistol above the target, stopping and lowering it to the final aiming area. Breathing is done as follows: From the “ready” position, the shooter inhales through the nose and raises the pistol, passing through the middle of the target. When the inhalation is complete, the raise stops at some point above the target. The shooter then slowly exhales through the mouth and control the air flow rate and the speed of lowering the arm. Exhalation stops when the sights arrive in the final aiming area.

The advantages of this technique are (overall technique):

- aiming while arm muscles are in eccentric action
- provides good control into the final aiming area
- allows sufficient aiming time
- technical skill is divided into simple elements.

The main disadvantage is that it is a complex skill (technique), requiring time to be adopted.

Double breathing technique is used when lifting the pistol above the target, 1st stop, lowering the pistol just above the black circle (or target), 2nd stop, and lowering the pistol into the final aiming area. The lifting of the pistol is the same as for single breathing. On lowering the gun, the shooter stops breathing for the first time together with 2nd stop of the pistol. The shooter then takes one short breath (inhale and exhale) while maintaining the steady position of the gun. The shooter then takes one short breath (inhale and exhale) while maintaining the steady position of the gun. The next part of the technique is to breathe out very slowly, together with lowering the pistol into the final aiming area. Advantages are:

- aiming while arm muscles are in eccentric action
- provides improved control into the final aiming area
- two stages lowering technique minimizing the arc of the movement
- reducing final aiming time
- technical skill is divided into simple elements
- increasing oxygen reserves

The disadvantage is that it is a more complex skill than the previous one and requires an even longer time to be mastered.

For both techniques, a sufficient amount of air must be inhaled to ensure enough oxygen.

Both methods are widely practiced and demand proper control of the diaphragm during breathing.

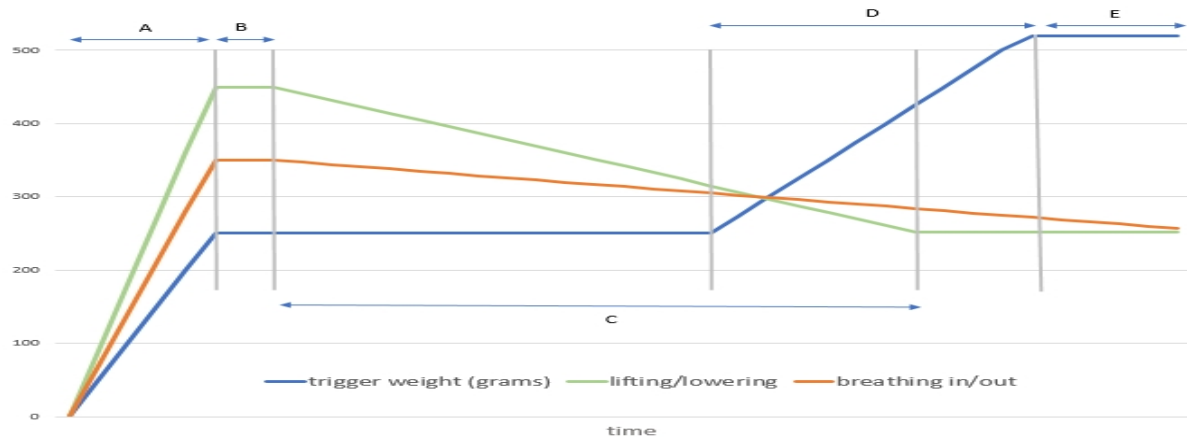

3. GRIP AND GRIPPING

In this material, as well as in the material of the previous course, there were many descriptions and explanations about grip and gripping techniques. There was talk about geometric requirements the grip must meet, how it is held by a hand, what the relationships are between hand, grip, and the weapon itself. We elaborated on how the standard grip can be modified and adapted to individual needs, as well as what the most common mistakes are that can be caused by an improper gripping technique. As this chapter is part of the practical part of this course, it will be the only chapter in which we will not deal further with additional descriptions and theoretical postulates. During the residential course, this chapter will be the subject of practical work. All participants in the practical part of the course will have a practical demonstration of customizing the grip, and then each of you will modify a personal grip. That is why it is necessary to take your grip, filling material, and necessary tools with you when coming to the course.

4. DETECTING CRITICAL POINT BASED ON SHOT GROUP

As in all sports, shooting sport athletes tend to repeat typical technical mistakes. In our sport, the target is a kind of book that can be “read”. Based on this, certain conclusions can be drawn. This paper describes some of the most common types of shot grouping, which are caused by some of the typical technical errors. For easier understanding, in the cases shown below, an Air Pistol target is used and has only a demonstrative role.

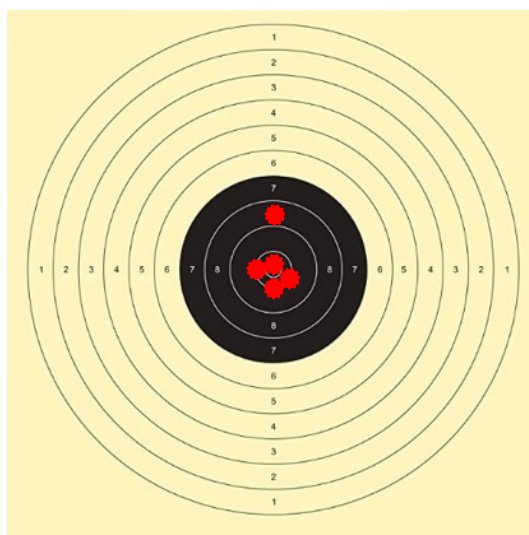

Case 1

Most of the shots are concentrated in a compact group, and one shot is at 12 o'clock in the eighth. In most cases, this type of error is the result of shifting the focus from front sight to target. When analyzing a shot like this, very often all the technical sequences are performed correctly. An explanation of the reason behind this type of mistake can be found in the "Sighting Technique" section (Künnapas framing theory). When the focus of the eye shifts from front sight to target, the white strip between the top of the front sight and the black circle appears larger, and the shooter raises the gun to restore its normal appearance. The consequence is high eight at 12 o'clock. This type of error is also present in the 25m disciplines. In particular, it can be seen in the precision part. In addition to the above reason, it may be the result of changing light conditions, but the mechanism that causes it is the same.

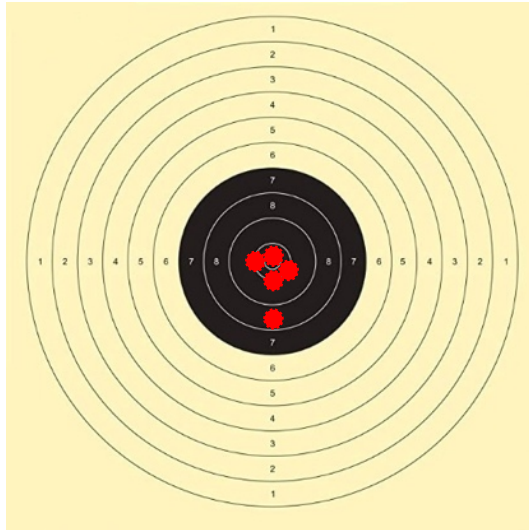

Case 2

The group of shots is located as in the previous example, with the difference that the eight is localized at 6 o'clock. This type of error occurs less frequently than the previous one. When it happens, it may be the result of one of the following reasons.

The focus of the eye shifts from front sight to rear sight. Changing light conditions can be another

reason, mainly in the 25m shooting range. The third reason may be improper gripping pressure, especially with the thumb. Fourth, and not equally frequent is the incorrect triggering technique (snatching).

Case 3

When the shots are situated along the diagonal line from 1-2 o'clock to 7-8 o'clock, the most common cause is in the different positioning of the left shoulder. This shoulder non-uniformity is a consequence of the different positioning of the left hand and/or left arm. Differences in positioning can be made in preparation for the shot, or during the execution of the shot. Anyhow, the outcome

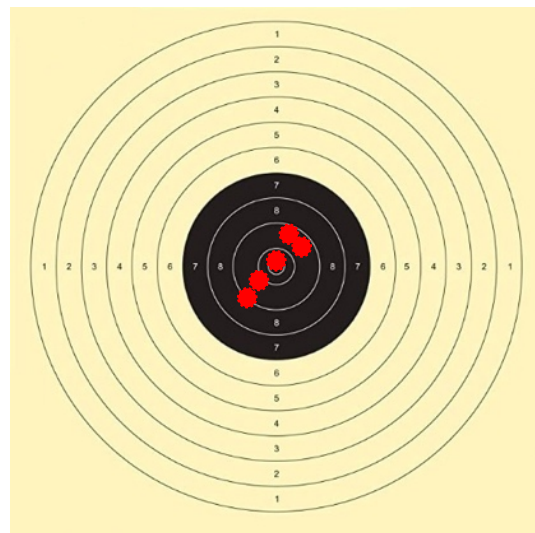

will be changing in posturology, resulting in this picture of shot grouping (Course No1 "The position of the left arm"). This is the most common reason, but of course not the only one. This picture can also be seen in the combination of errors that occur in the triggering or gripping technique.

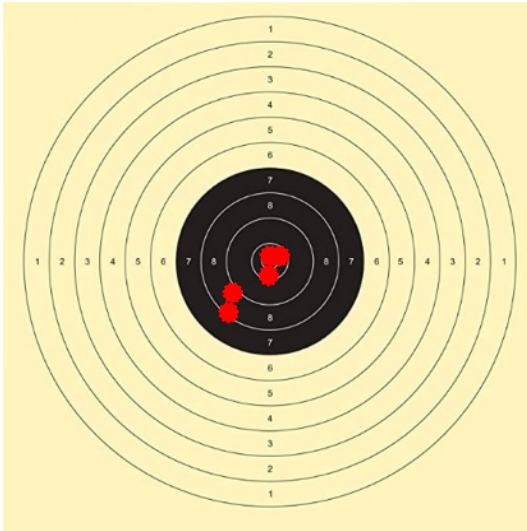

Case 4

When one or two shots "jump out" of the basic group and are situated within a weak nine or eight at 8 o'clock, we notice another classic mistake. This is one of the more common mistakes, especially among beginners but can also be seen with top shooters, especially in extremely stressful situations. In both cases, there is a triggering error

(snatching), but the reasons are different. With beginners, this error occurs mainly due to attempts to "hunt the ten", while with top shooters it occurs for one of the following reasons: The first is the uncontrolled pull of the trigger, due to mental misdirection/distraction. The second reason is that the shooter "missed" the optimal triggering time and entered the fatigue zone, resulting in uncontrolled second triggering stage - snatching.

Case 5

When the shots "fly" from the group and landing in eight or a weak nine zone at 1-2 o'clock, diagonally opposite to the previous mistake, they usually appear due to a wrong gripping technique. In 90% of cases, it is excessive gripping pressure, especially in the area of the last phalanges of 3-4-5 fingers. To create this type of pressure the group of the external

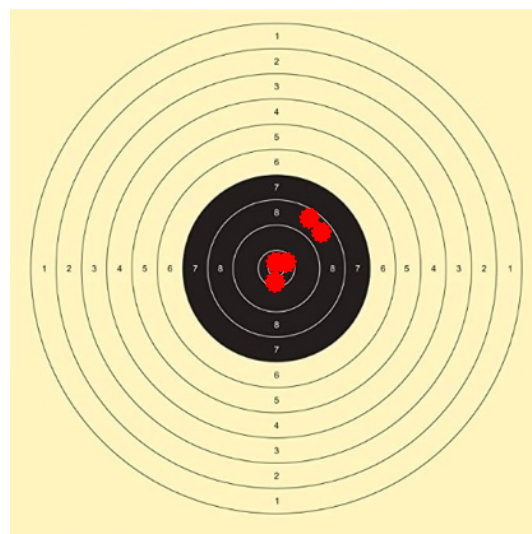

muscles between the hand and the elbow is in increased contraction activity. This activity

predominates especially at the time of firing the shot, causing the shortening of these muscles. The result is that the hand is moving to the right and up, causing shots to land in the described area.

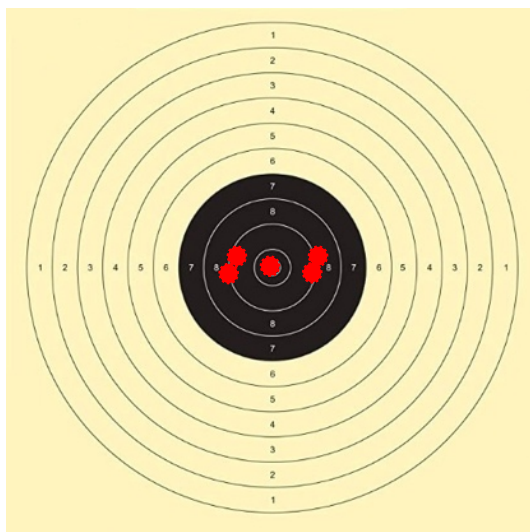

Case 6

The positioning of the shots to the left or right of the center of the target is mainly seen in insufficient body balance. This lack of balance can be caused by an incorrectly taken position. Insufficiently activated muscles that control core stability is another reason for insufficient balance. To correct this type of mistake it is recommended to retake the

position or increase the activity of the lower abdominal and back muscles.

Case 7

A common mistake encountered by more advanced shooters is characterized by very well-executed shots technically but, a significant number of them end up very near the center, resulting in a lower level of series points. By the simple use of the optoelectronic devices (SCATT), we can conclude that the shooter, in the second phase of the triggering technique, is

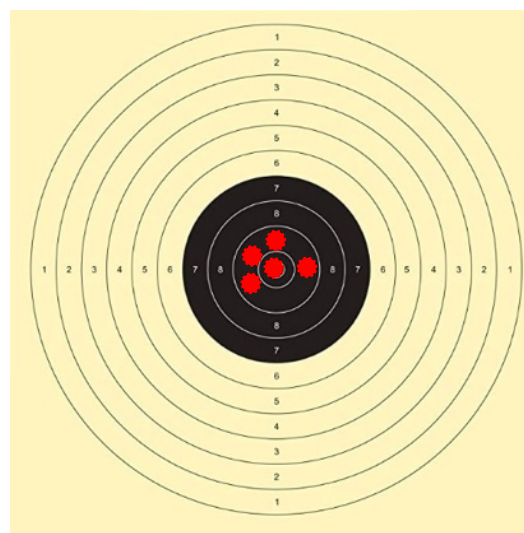

usually delayed by about 0.5 seconds. To correct this error, the shooter must execute the triggering technique with more confidence, without hesitation.

5. CORRECTIONS OF THE MOST COMMON MISTAKES

From 30 years of personal experience working as a coach, various professional seminars and existing literature, the most common mistakes can be categorized into four major groups regarding the *position, aiming/sighting technique, triggering technique* and *follow through*.

In this paper, those will be subject to elaboration, to some degree.

Position

Regardless of the discipline (AP, SP, or RFP) basic requirements have to be obtained. We discussed them in the first-course material. Anyhow, even concerning the maximum stability, the minimum arc of movement and correct absorption of the recoil, shooters very often tend to neglect the necessity to provide *muscle activity without unnecessary tension*. This is one of the first mistakes from the list of most common mistakes in pistol shooting. Best example is inconsistent and unnecessary gripping force, which is responsible for a great number of performance mistakes and diminishing desired result level. High position of the right shoulder is another example of high demand for muscle activity.

In the first course papers it was stated that the *wrist should be locked*, in all pistol disciplines. Correctness of this statement is something that all shooters and experts agree upon. Lack of meeting this requirement is another of the most common mistakes. There are different opinions about the consequences of a loose wrist joint, and therefore different technical approaches on how to deal with this problem. Yur'yev (1973) was making a statement that “the predominant movement caused by the wrist is one with a small angle to the vertical, and that the wrist immobilization is improved by a downwards inclination of the hand”. This might be the truth concerning a loose wrist, but only regarding vertical displacement. The existence of the

horizontal movement caused by a loose wrist is without any shadow of a doubt. Proof for Yur'yev's statement we can find in the work of advanced grip makers such as Dmitry Afonin, who makes grips that accommodate downwards inclination of the hand of the shooter, thus improving wrist immobilization in the vertical axis. Nevertheless, Piddubnyi (ISSF, 2003) states that the angular factor is only applicable to rifle shooting. In pistol shooting, according to his statement, mistakes in the horizontal axis are caused by wrist and hand motion. Piddubnyi states that the loose wrist is causing more mistakes than aiming errors. He describes that if the wrist is not fixed relative to the arm during aiming and the trigger release, large shot errors will occur. This actually means that there are also horizontal mistakes caused by the loose wrist. I do not agree with his statement that the angular factor is not part of horizontal mistakes. Anatolii Piddubnyi and I met for the first time in 1991, while he was working in Portugal. During years we came to know each other rather closely through our coaching activities, and on many occasions we were exchanging ideas and opinions about shooting. Regarding his statement above, we had a discussion that resulted in my research about angular factor mistakes in pistol shooting. Long story, short story, there is an impact of an *angular factor* in pistol shooting if the wrist is properly fixated. All the findings were demanding to make a different approach, especially on intellectual acceptance of this aspect of pistol shooting.

In late 2006, young French shooter Clément Petitot, IT student at that time, made a simple program interface simulating possible results based on angular factor. Let us take an example, if the shooter was shooting 10,0 on Air Pistol, what should the point value be on SP Precision or FP if a mistake was due to angular factor mistake. As shown in the photo, the value for SP Precision would be 10.3 and 9.5 for FP.

Point value :

Distance :

Bullet :

Pistol
- 10m : 10
- 25m : 10.3
- 25m RPF : 10.6
- 50m : 9.5

The next calculation was done by getting the program to calculate what the point value for AP would be if one would like to shoot 10.0 in SP Precision. The answer is 9.7.

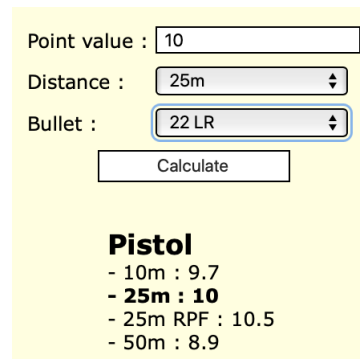

Point value :

Distance :

Bullet :

Pistol

- 10m : 9.7
- **25m : 10**
- 25m RPF : 10.5
- 50m : 8.9

Establishing a fact that angular factor is existing and showing the mathematical calculation of the point value, has changed

both technical and mental approaches of shooters across disciplines. Examples have shown that if an AP lady can develop a shot delivery technique, placing 10 shots within 9.7, most likely (with proper ammunition selection) she would be able to make 100 points on the precision stage of Sport Pistol. Proving angular factor and adopting mathematical calculation made French SP Women winning the first medal in this discipline after 17 years, and secured that in the next decade. They were regular visitors on the podiums across all major international competitions. In the next Olympic cycle, I was engaged in work with the Italian Pistol Team. With FP Men, using these simple findings, we established an approach that we called “Italian Ten”. Italian FP shooters, both in junior and senior category become most dominant European shooters in FP, as well as major players on the World stage.

The angular factor is closely related to the next most common mistake, *alignment with the target*. Here we are talking about mistakes related to incorrect establishing of “zero position”. This topic has been elaborated in detail in the papers from the previous course – chapter “Approaching Shooting Position”.

Aiming/sighting technique

When we talk about aiming/sighting technique mistakes, several different mistakes can happen during these processes. In this chapter, the four most common ones are selected: lateral sighting mistakes, vertical lifting mistakes, aiming too close or too far from the center of the

target and aiming for too long time. The first two errors are closely related to the lifting technique and errors during its execution.

Lateral sighting mistakes

As previously described in the "lifting technique" section, the shooter should adopt the technique by which he passes through the center of the target when raising the pistol, and then returns to the final aiming area with the same trajectory. A common mistake that we can notice is the inconsistent way of raising the pistol, which leads to an inconsistent approach to the final aiming zone. The second type of error consists in the way of raising the gun when the lifting path is stable, but in the form of a curve until it reaches the "rough aiming area". Both types of errors result in lateral errors, which, as a rule, lead to horizontal displacement of the shot. These unwanted errors are most easily registered using optoelectronic equipment, such as SCATT, Noptel, Rika, etc. Less sophisticated and cheaper devices can be used, such as video cameras or simple laser devices that can be mounted on the barrel of a weapon.

The solution to solving this problem is in the correction of the lifting technique. The process is rather simple but requires disciplined and dedicated work to advance the lifting technique. As an aid, one of the previously mentioned devices can be used as feedback, as well as the use of vertical stripe targets. Dry firing training is the most desired methodology in overcoming this mistake.

Vertical sighting mistakes

Another type of error that is closely related to the lifting technique is the vertical sighting mistake. A common occurrence that can be seen is in the process of reaching the final aiming zone. The shooter misses the stop point, and the sighting elements "sink" lower than desired. Such a situation demands concentric muscle action resulting in neglecting benefits of eccentric muscle activity.

As with the previous error, this phenomenon can be registered by one of the mentioned devices.

Correction of this problem also consists of improving the lifting technique, in the part concerning bringing/lowering the pistol to the final aiming zone. The correct slowing zone must be respected. As an auxiliary alternative, an adapted breathing technique can be used to overcome this error. When the shooter "misses" the stop zone and goes lower than desired, controlled breathing inhalation can help to return the sighting elements to the final aiming zone. This technique is very often used in the FP discipline, but can also be applied in other precision disciplines if needed.

Aiming too close to the center of the target

I will agree with the possibility that the above definition may not be the best choice. In any case, this is a situation where the shooter aligns the sighting elements in precision disciplines ***too close*** to the black circle of the target.

This type of error occurs due to the belief that vertical errors are eliminated due to the possibility of the inconsistent distance between the black circle and sighting elements. Of course, this is wrong for two reasons:

First of all, in this way of sighting is not possible to focus only on the front sight. The too-small distance between the target's black circle and the front sight makes it impossible.

The second reason is in the fact that, even with the sharpest focus of the front sight, the upper edge of the front sight is not seen as a clean line, but as a black surface with traces of the shadow. The same effect exists on the black circle of the target.

When the front sight is too close to the target's black circle, the two shadows are overlapping, making it impossible to clearly separate those two surfaces.

For these reasons, it is advisable to use the aiming technique which is described earlier in this paper.

When we talk about the dynamic disciplines, SP-RF or RFP, we have a situation where the shooter is aiming ***far from the center*** of the target. Namely, I have been in a situation several

times where the shooter explained to me that it is more efficient to aim at the bottom of the target (target frame), explaining this by arguing that in this way the movement from "ready position" to final aiming area is shorter. This may seem like a reasonable explanation, but only for someone who does not understand the basics of ballistics and the functioning of the rear sight mechanism.

Let us elaborate on this statement. For a moment we will eliminate the effect of the earth's gravity, the decrease in bullet speed, and the possible influence of wind or some other external factor that affects the trajectory of the bullet. For a bullet to hit the center of the target, the barrel axis must be an extension of the line extending from the center of the target to the barrel chamber where the bullet is located before firing.

This means that regardless of how the sighting elements are arranged, the axis of the barrel must always be in direct relation to the center of the target. Better to say, where the axis of the barrel is directed, there will be the bullet impact.

Aiming picture - is the relationship between the sighting elements of the pistol - front & rear sight, and target, and does not affect in which direction the barrel axis is placed.

For example, we can adjust the sighting elements to aim at the ground in front of the shooter and hit the center of the target, or we can adjust the sighting elements to aim at a neighboring target, and hit the center of our target.

Conclusion:

Regardless of the low aiming point, if shots are placed in the center of the target, the axis of the barrel is also at the height of the center of the target. So, it is not true that if aiming in the lower frame of the target that the lifting travel of the pistol is shorter.

Aiming for too long

The main goal and desire for every shooter is to shoot a ten - every time a shot is fired. It is legitimate, and to do this the shooter has to align the sighting elements properly in the final

area without the necessity for correction, and properly pull the trigger. It sounds easy, but... Delay in aiming is another of the common mistakes that can be the result of three factors: *incorrect aiming picture*, *incorrect triggering action* and *lack of focus on the front sight*.

The lifting technique is one of the main reasons that results in an incorrect aiming picture. As we saw earlier, the correct lifting technique is one of the more responsible factors of successful shot execution. Errors in its execution can be manifested through several aspects, and one of them is prolonged aiming. It is the product of the correction of the above-mentioned error. Its correction is not in the process of prolonged aiming itself but in the cause that led to it, incorrect lifting technique.

Another reason for aiming time that is too long is in the incorrectly performed triggering technique. Here too, it is important to point out that aiming time that is too long is the result of not doing something correct within another process, then it is a cause for itself. The most common causes of malfunction in triggering techniques are described in the next paragraph.

Lack of, or insufficient focus on front sight can be caused by various factors. Eye fatigue, not using a filter, or using an inadequate filter are just some of the reasons for the lack of sufficient focus on the front sight. Another common reason for this type of mistake can be found in the misplaced width of the rear sight. Shooters very often narrow the rear sight too much because they think that this improves the accuracy in the horizontal plane. In fact, they make a mistake with the same principle of action as when nearing the front sight regarding the black circle (see above description).

Triggering technique

Saying that triggering mistakes are one of the most common mistakes, I would like to refer to mistakes made by the shot release. It does not mean that there are no mistakes in other parts of

the triggering process, but most often those in connection with the last part of the triggering technique. If all the elements of the technique that precede the final part of triggering are carried out accurately, we can say that all the conditions for a successful shot have been met. The only thing that can disrupt the satisfactory outcome of the shot is late delivery of the last segment of the trigger segment - shot release. In real life, we most often see *trigger snatching* or jerking and *trigger freezing* mistakes.

Trigger snatching most often occurs just before firing the shot and causes the pistol barrel to move violently, producing a poor shot value. This phenomenon is most often seen in beginners and intermediate shooters, but sometimes can be seen in the performance of top shooters during exposure to maximum stress. Viewed from the aspect of mental performance, triggering should be performed subconsciously, automatically, in an optimal time interval, as a result of the correct aiming picture and stable holding. As very often these two preconditions are not met, the shooter consciously moves the last phalanx of the index finger, causing snatching of the trigger.

Yur'yev (1973) states that "controlled trigger release should be taught at the earliest opportunity in a shooter's training and constantly reinforced. Failure to do this will result in snatching the trigger or other involuntary actions which can adversely affect the shot quality. These actions can be blinking, tensioning muscles in the hand or arm, moving the head or shoulder. To address snatching, Yur'yev recommends cessation of live shooting and start dry-firing, to ...allow the nervous system to rest...". This type of error occurs as a consequence of sufficient mental preparation and is manifested through the fear of making the mistake, a poor shot. This fear is neglecting the process of triggering and its execution, as planned.

Solutions for resolving errors that occur during the triggering technique are found in the proper training methodology of this technique, as well as with compatible mental training. A great contribution to overcoming these problems will be the experience that can be gained during

test matches, as well as through smaller, developmental, domestic and international competitions.

The most common and explicit mistake encountered on all shooting ranges is a failure to execute *follow through technique*. The process of a correctly executed shot implies precise and systematic execution of each segment of all mentioned techniques - lifting/sighting/triggering; as well as creating conditions for the bullet to leave the barrel without the influence of any premature and unwanted force. The need to execute correct follow through technique is reflected, not only in physically keeping the weapon pointing towards the target. This process makes it possible to obtain the necessary information in the form of feedback, regarding shot execution. Another important segment relates to the mental endurance and consistency of performing the entire complex process of coordinating the various techniques needed to successfully deliver the shot. The lack of follow through techniques indicates the premature termination of some segment of the mentioned techniques. This shortcoming is usually caused by the increased desire of the shooter to see the result of the delivered shot. The moment after the shot is fired, the head moves towards the monitor. The shooter must understand and accept that the follow through technique is an integral part of the correct shot execution, not an isolated part of the technique left to the free choice of the shooter.

Self-evaluating question

Describe the most common mistakes and solutions for overcoming those.

6. TACTICS IN SHOOTING

This paper is describing some elementary suggestions for carrying out tactical preparation for the competition. Tactical preparation considers the preparation procedures before and during the competition period.

Tactical preparation for the competition begins weeks prior to the competition. It is a process that includes not only training units, but all necessary arrangements (traveling, accommodation, pre-competition training) and necessary evaluations and analysis prior, during, and after the competition. Meticulous planning is a must for successful performance during competition.

BEFORE THE COMPETITION

Training before the match

The task of the coach is to obtain and present as much information as possible related to the conditions of the shooting range where the competition takes place. This primarily refers to the appearance of the shooting range, where previously photos and videos taken can be of great help. If the coach does not have this information, it is possible to search for it on the Internet or ask the organizer or an acquaintance to send from the place of the competition. It is necessary to present the climatic conditions expected during the competition, as well as the specificity of the light, both at 25m and 10m shooting ranges. It would be desirable to make as detailed records as possible during each visit to the shooting ranges so that they can be used at a given moment.

The goals during the training camp should be adjusted to the main goal of the competition, in order to train the most realistic elements that need to be implemented in the competition.

When it comes to traveling to international competitions, there are two models of preparation and a trip to the destination that takes a couple of hours and overseas traveling. In both cases, common elements are checking the possession and validity of travel documents, passports, visas, ticket reservations, the total weight of equipment, etc. It is also important to choose the optimal time of arrival at the destination, to provide optimal conditions for all activities that need to be done during the arrival day (weapon pickup, which may take time depending on customs and police security procedures of the host country). Following the choice of the start of the trip, the time required for the procedures for leaving the country from which the trip starts should be planned. Upon completion of the arrival procedures at the destination, the time required for the transport and delivery of weapons to the shooting range, as well as obtaining accreditations for the competition should be taken into account. The next stage is the arrival at the hotel and all the procedures that must be done at the hotel. All this sounds quite simple, but very often it takes a long time to get from the moment the trip begins to the time when athletes can relax and rest. The result of the competition can also depend on the accuracy of travel planning.

It is necessary to follow the unwritten rule not to train on the day of arrival at the destination. Premature arrival at the destination, when there are several days between the day of arrival and the possibility of training is not recommended, because it can negatively affect the mental state of shooters due to lack of adequate activities.

When traveling to long intercontinental overseas competitions, special attention should be paid to the accommodation of athletes. Jetlag requires a longer period of recovery and adaptation, both physically and physiologically. Especially pronounced is a sleep disorder, which affects the overall functioning of the athlete. It is well known that long international flights to the east

require a longer period of adaptation than when traveling to the west. During long flights, special attention must be paid to adequate fluid intake to compensate for the negative effects of long stays in airplane cabin conditions. Adequate physical activities during long flights are mandatory to maintain the normal functioning of the athlete's circulatory system. Upon arrival at the destination, it is necessary to follow the previously created plan of activities for the following days.

Accommodation and food

It is highly recommended to book a hotel recommended by the organizer of the competition, as transportation to/from the shooting range is included. Making a reservation in good time, gives the possibility to choose one of the nearest hotels to the shooting range. It would be ideal if travel time from the hotel to the shooting range is within approximately 30 minutes. The traveling schedule has to be tested during training days and finalized before competition day(s). Rooms should be reserved in a way that shooters competing in the same discipline will be sharing the room, avoiding disturbance in sleeping time. At least, roommates should have similar daily sporting activities.

Eating habits must be adopted to the safe consumption of food. Bottled water, cooked vegetables, well-cooked meat and peeled fruit are some of the examples that are recommended. Any milk product food, seafood, and specially prepared exotic food should be avoided before the competition. Too often athletes neglected their competition due to various food poisoning.

Activities at the competition site

ID –cards

All members of the team, athletes, coaches, officials must obtain ID cards.

Start lists

It is necessary to obtain information regarding start lists for PET and competition.

The PET is conducted on the same firing points as in the qualification round (competition). The start lists are published latest the evening before the competition, if not earlier.

Shooting Range

Shooters, together with the coach should visit the shooting range and make necessary notes regarding conditions on the shooting range. This activity should be done on the first day upon arrival.

Equipment and weapon control

Following technical rules, it is advisable to make technical control on the first day of shooting range visit.

The storage of the weapons and equipment

Athletes should deliver their weapons and ammunition to the designed storage room and collect information regarding rules for delivering and taking weapons and ammunition during competition days.

Targets

Inspection of the targets and light conditions is part of the standard procedure.

The location of the weapon and ammunition manufacturers, team room, bathroom, and doping room, should be noted during the first-day visit.

DAY BEFORE THE COMPETITION

The Pre Event Training is taking place one day before the competition, on the same firing point as in the competition, but seldom at the same time as the time for the competition. Anyhow, the shooter should try to take advantage by getting familiar with the conditions and circumstances of his/her firing point as much as possible. When talking about Air Pistol

discipline, the main goal is to make proper adjustments of sighting elements so that the shot group is in the middle of the target. The situation with SP and RFP is rather different, as daylight characteristics during PET are most likely not the same as during the next day. Shot grouping can give rough orientation for the setup of sighting elements. The information regarding possible wind behaviour could be beneficial in outlining the final tactical approach for the competition.

The evening is reserved for a team meeting. All necessary information, regarding wakeup time, breakfast time, shuttle bus schedule, the pre-competition routine should be defined in its final form. Notes and information taken during PET are presented and analyzed. The final reminder of goal setting and tactics necessary for the competition are outlined and finalized.

After dinner, athletes should follow pre-trained routines and activities. Certainly, this is not the time to get “out of the tracks” and try something that is out of the usual competition behaviour.

DAY OF THE COMPETITION

Wake up time and choice of a meal are important elements of the competition day. These topics are in the responsibility of the specialists in those areas, and therefore will not be elaborated further in this paper.

Tactics during the match

Final tactics are decided the last evening and should consist of two sets: The main tactic and substitute tactical approach if conditions during the match are asking for it. Competition goals and various tactics have been subject to the training camp(s) before the competition. Tactical routines regarding physical and technical warm up are carried out with regular routine. A list of performance goals in longer or “keyword” form has to be followed, as it was trained. In the

case of some irregular situations appearing, the proper tactical solution should be engaged. All those various scenarios have been subject to training camp(s) activity.

An important part of the tactics during the match is shooting rhythm. During Air Pistol competition, as the conditions on the shooting range are constant and competition time is at the athlete's disposal on how to use it, the athlete is proceeding with predesigned tempo and tactical breaks. If an athlete is not able to deliver agreed rhythm for some reason, it is advisable to take a break or look for instruction from the coach, as another tactical approach might be selected. The situation with SP and RFP is much different. Besides the personal state of the athlete, weather conditions might be changing during the match and can result in the necessity of changing the tactical approach. The key to a successful result in the competition is always in the quality preparation during training camp(s) before the competition.

Analysis

My suggestion is that right after the competition, the coach should get short feedback from the shooter. It can be very worthy information on the emotional and psychological status of the athlete. The analytical discussion will take place later during the day, the latest in the evening during the team meeting. This procedure is very important, as usually during the international competition there is another match, sometimes in the same event or a second part of the event (SP and RF) or second event. It means that work is continuing and analysis should be taken as preparation for the next start.

The additional file can be used as reminder or check list.

[See the attached file – “pre_comp_cl”.](#)

7. SHOOTING DIARY

In this chapter, we will elaborate basic elements of writing and using a shooting diary. Very often we see that shooters and coaches are both taking notes or writing something in their notebooks on the shooting ranges. Said that, we can state that there are two kinds of shooting diaries; one for the shooter and one for the coach. Both parts are dealing with a large amount of information, so there is a need for the optimal format of gathering these and a system of using them. The reason for keeping the record of our activities is to improve the logical order of our plans and goals, as well as thoughts and actions. We practice the sport that demands maximum precision in its essence. We need to act in every segment of our daily activity, especially during the time we are spending in and around our sport, with maximum precision in behavior. Keeping a precise record of the activities of the sport is rather a must than free will for everyone who strives to become an elite shooter.

Let us first elaborate the diary of the shooter. First of all, it is personal information recorded by the shooter and the content should be revealed to others only by consent from the shooter. Some diary information can be used by both shooter and coach, such as weapon setup changes and ammo selection. This information should be given in the case that the coach, for some reason is not able to access, or is in the situation where a new coach is taking over the position of personal/national coach.

An often asked question is how much information a diary should contain. Besides basic info, like event, date, time, temperature, weather conditions, location and result, a diary should keep records of training/competition objective. Self-evaluation can be done either in form of

quantitative (numeric) measurement or qualitative (description) measurements. A very important part of the diary belongs to *Performance Analysis*. Based on the given objective and delivered performance, the shooter should make notes on Success Analysis and Solution Analysis. The conclusion of these two analytical processes will largely help in defining the goal for the next training session.

Diary records can be done on two levels - one for daily training purposes and one for the competition purpose. Information written during competition should contain some additional information - the layout of the shooting range, the light at the shooting range, height of the table at the shooting stand, approximate correction of the sighting elements, etc. Nowadays, with all modern electronic technology accessible to all shooters, it is possible to find and/or make personal diary applications that will also enable them to take photos or a video recording of the shooting range and environment. This can be a great help for the shooter to make optimal preparations, if in the future will compete again on the same shooting range.

Furthermore, the shooter can use a diary to write down the time for the team meetings, shooting time, number of the firing position, transportation schedule to the shooting range, and equipment checklist. Goal setting and performance goal list should also be recorded in the diary.

Daily training and competition records should contain the coach's instruction and evaluations. The coach's diary has a lot in common with the shooter's diary, but it also has its own characteristics. They are reflected in whether the coach is involved in individual work with one or two shooters or is involved with a larger group, such as working with a national team. Depending on this, the contents of the journal may vary. The example given (see the end of the paragraph) contains a large amount of information, which can be used for a possible report if necessary. The diary must contain all the general elements needed for the group, the main strategic goal for the training camp, the time table, the discipline division, etc. It must contain

individual and collective description of the state of performance at the beginning, during, and at the end of the camp. Which individual recommendations are given, as well as their effect on the shooter's performance? It must contain an individual and general evaluation and conclusion at the end of the training camp. Based on this information, a work program and goals are made for the next training camp. By comparing data from the diary, the progress of the performance of the group, and individuals in relation to the strategic goal can be monitored. Of course, in accordance with the conclusions, the necessary modifications can be made in order to optimize the conditions for achieving the desired form of the athlete and/or team.

For this chapter you can read and/or use two additional files:

- Example of coach diary that can also be used for report

[See the attached file page 1 -15 – “diary_coach”.](#)

- Example of shooter diary, which can be adopted for personal use

[See the attached file – “diary_shooter”.](#)

Self-evaluating question

Describe the content and use of a diary, for shooter and coach

8. USE OF OPTOELECTRONIC EQUIPMENT

The need for human society to develop in all areas of technological innovation has not bypassed shooting sports. In 1982, the Finnish company Noptel began its production of optoelectronic devices intended for the development of shooting sports. The first quality product, which we know in today's format, was Noptel ST 1000, which appeared at the end of 1988/9 and represented the father of the art. The response of a group of Russian enthusiasts in the form of the Scatt device, a company that started operating in 1991, soon arrived. The latter, market also saw some other equipment dealing with similar needs.

Noptel and Scatt found their daily use in the training activities, as well as in scientific research together with other kinds of equipment (EKG, force platforms, breathing devices, etc). In daily routine shooters and coaches use optoelectronic devices for two purposes: diagnostics and as training equipment in restricted conditions (use at home and/or when shooting range is not available). Great benefits in using them for training purposes are their small size, mobility, saving ammunition cost if used for dry firing, and saving time if using it at home. When using these devices for diagnostic purposes a variety of useful information are provided. For more simple terminology we will be talking about Scatt, also as described examples are performed by its use.

Scatt accurately and objectively measures and records the shooting activity, providing immediate feedback on each shot thus making the training very efficient. It would be a mistake if one thinks that the use of Scatt is reserved exclusively for elite shooters. Great benefits can be achieved in use with beginners and medium level shooters as well.

Using the Scatt the shooter and the coach can monitor and correct the three most important factors of the shooter's performance – posture, sighting, and triggering control.

Scatt provides statistical data and graphics for distance from the center in the x and y-axis, coordination between sighting and triggering, the rhythm of shooting, score foreseeing depending on the moment of firing, and projections for ammunition spread.

In the attached examples you will notice that the screenshots are showing the use of Air Rifle, but the same explanation and principles apply to any pistol discipline.

Let us start by showing the trace lines of the movement of the weapon on the screen.

For easy following the process of the shot delivery, the trace is marked in different colors and is limited by time intervals:

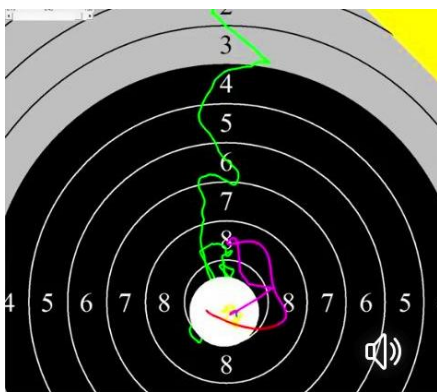

Green line - display time can be set by the user

Yellow line – 1.0 - 0.2 seconds before firing

Blue line – 0.2 – 0.0 seconds

Red line – movement after firing

Individual description of each part of the trace:

Green line – represents the way of approaching the center of the target. It shows the time and direction of the approach. By selecting the ``All Traces`` button from the menu, the shooter can see all the traces from a series of ten shots. The consistency of the approach shows whether the shooter brings the weapon to the center of the target in the same way and in the same direction consistently.

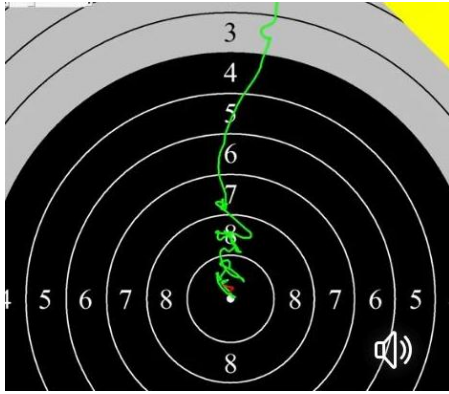

Yellow line – represents the final second before the shot is fired. This part of the trace shows a few things:



- Position of hold - is related to the aiming
- Speed of movement in mm/s – the "length" of the trace in millimeters is indicated in the lower-left corner
- Size of the aiming area – is related to stability and steadiness
- Shape of the aiming area – is it round, more horizontal, or vertical

The shot is correctly executed when the trace is as short as possible, moves slowly having a round shape, and is located in the center of the target.

Blue trace – the last 0.2 seconds before the shot is fired. It shows what happens during the trigger release. The short trace, almost like a dot, means that the triggering is smooth and clear. In addition to the smooth and clear triggering, the length and direction of the blue line indicate whether the position of the finger on the trigger is good. If the blue line is directed to the left, it means that the trigger is far away and vice versa.



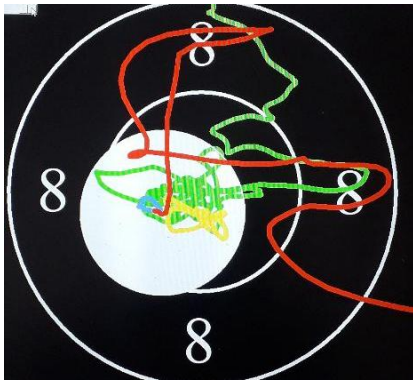

Red line – represents the recoil of the weapon. It lasts about a tenth of a second and normally is straight up when using Air Pistol, or up and left when using SP and RFP. Its height varies depending on the weapon we use, the weight and balance of the weapon, and the stability of the shooter's position. After recoil, the weapon falls back down. If the

movement is natural without any other force, and ends near its start point, the red trace shows the good follow through technique.

On the left side of the screen is displayed a table with numerical indicators of the shot processing. The most common indicators are: shot index, shot orientation relative to the center, and shot value. We can see different time parameters.

Aiming time, 10.0 – is the ratio of hold inside the 10.0 ring. 10a0 – is the ratio of hold inside 10.0 ring diameter centered on the average aiming point, measured in mm/s – aiming trace speed (the

| # | Result | Time | 10.0 | 10.5 | 10a0 | 10a5 | mm/s | mm/s/250ms |
|-----|--------|------|------|------|------|------|------|------------|
| 1 | 10.8 | 10.4 | 100% | 67% | 100% | 97% | 10.6 | 1.3 |
| 2 | 10.5 | 11.3 | 100% | 90% | 100% | 94% | 11.0 | 9.6 |
| 3 | 10.1 | 13.5 | 99% | 34% | 100% | 100% | 11.9 | 13.4 |
| 4 | 10.5 | 10.5 | 100% | 68% | 100% | 87% | 10.0 | 7.1 |
| 5 | 10.4 | 8.5 | 100% | 88% | 100% | 91% | 12.9 | 13.3 |
| 6 | 10.8 | 12.1 | 100% | 89% | 100% | 97% | 10.5 | 10.6 |
| 7 | 10.9 | 10.9 | 100% | 83% | 100% | 97% | 9.9 | 8.9 |
| 8 | 10.5 | 7.7 | 100% | 98% | 100% | 95% | 10.4 | 9.8 |
| 9 | 10.7 | 12.6 | 100% | 80% | 100% | 92% | 11.4 | 11.9 |
| 10 | 10.5 | 13.0 | 91% | 44% | 100% | 93% | 12.2 | 11.0 |
| 100 | 105.7 | 11.1 | 99% | 74% | 100% | 94% | 11.1 | 10.6 |

length in the last second before firing). Value mm/s/250ms - represents trace speed (the length in the last 250 ms before firing). DA – the distance between the average aiming point and breach. More demanding shooters can extend the list that includes a ratio of hold inside 10.5 and 10a5.

Explanation of individual indicators:

Time should be as constant as possible within a maximum of 2-3 seconds. 10.0 and 10a0 show the steadiness of the weapon. The higher the ratio is, the stability is better. When the percentage at 10.0 is significantly lower than 10a0 it means that the shooter made an aiming error or did not adjust the rear sight properly.

Mm/s shows the steadiness of the weapon during the final aiming procedure. It should be lower than 15 mm/s if desiring to achieve high results. Mm/s/250ms shows the final action of triggering. Smooth and clear triggering gives a lower value. DA represents the coordination between the aiming and triggering techniques. The lower the value, shows better coordination. At the end of a series of 10 shots and at the end of the whole session, the average value for all shots is calculated.

General info related to the entire training session

Ivana
10m Air Rifle (4.5 mm)

SCATT Shooter Training System
2/11/2020 10:03:24 AM



| | |
|--|---|
| Number of match shots | 60 |
| Result | integer 600 fractional 628.7 average 10.5 |
| Result for the shot group in relation to the center of the target | 629.7 (+1.0) |
| Total shooting time | 01:01:29 |
| Average time per shot | 00:01:01 (00:00:37, 00:05:34) |
| Stability of time interval between shots | 61% |
| Diametrical dispersion (group size) | 3.9 mm |
| Stability of aiming | 3.9 mm |
| Accuracy of shooting | 0.5 mm |
| Average steadiness in 10.0 | 96% |
| Average length of a tracing | 12.2 mm horizontal 8.5 mm vertical 6.9 mm |
| Elliptical factor | for group 1.05 for tracings 1.25 |
| Control interval | 1.0 sec |

Statistical data and graphs allow the shooter and the coach to get a complete analysis of the performance and all shooting techniques. Based on the findings, it is much easier to correct mistakes and make plans for the next training unit.

By comparing the listed data from two training units it is possible to monitor eventual progress.

Distance

This graph shows whether the balance of the position and the shooter-weapon arrangement is good. It can be seen that the movement of the weapon in the horizontal plane is slightly larger than in the vertical. If the lines are relatively straight and parallel it means that the balance is well set.



Coordination

Here we can see the coordination between aiming and triggering activity. The smoother the curve, the better the coordination. This is especially valid for the segment that shows coordination in the last second before firing.

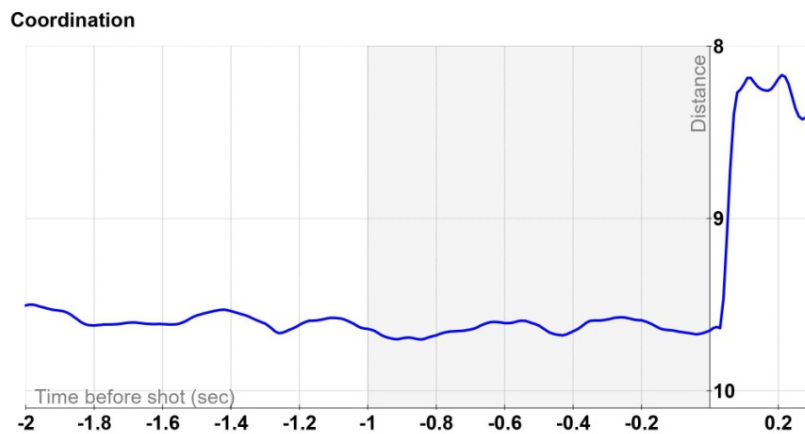

Shooting rhythm

The graph determines whether the shooter manages the match adequately, according to the tactical tasks. It indicates predesigned tactical breaks, breaks due to a drop in concentration, or breaks after a weak shot.

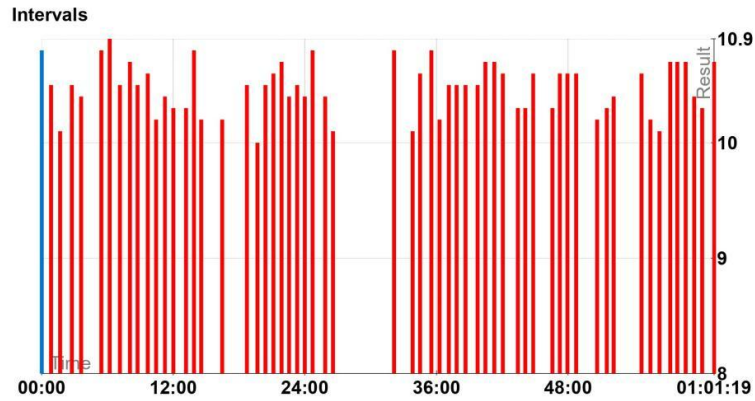

Shift

The anticipation of the score value in relation to the moment of firing. An analysis is showing that the shooter could have fired earlier and achieved the same result. This statement is related to the stability of the weapon, but the triggering process was not fully prepared. Usually, the theoretical highest result value is 0.2 seconds before the actual firing. The reason is in the fact that the shooter is always "seeing" the old picture due to the time necessary for the brain optical center to process received information. Simply speaking, we know this delay as "reaction time".

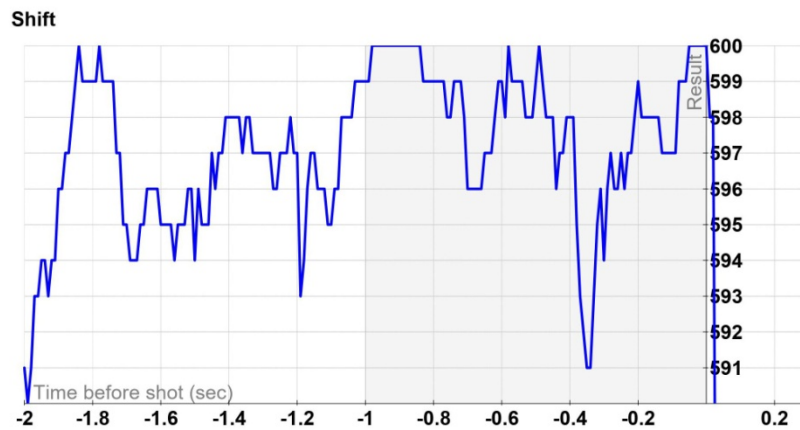

Probability

Projections concerning ammunition spread. This chart shows the need for quality and tested ammunition. The result is the same if the ammunition spread is up to 1 mm in diameter. This means that if the zero spread is 4.5 mm, it is acceptable to go up to 5.5 mm. Mostly, this is desired diameter when testing specific pellets.

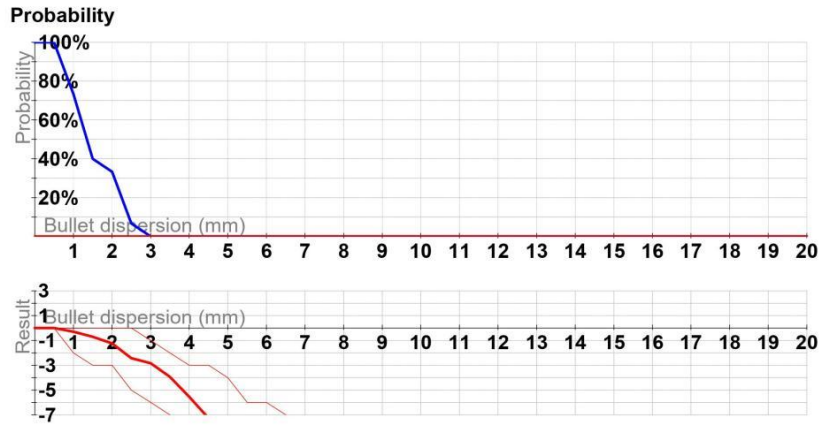

Conclusion: Optoelectronic equipment is not a luxury, but a daily necessity for any serious shooter and coach.

Self-evaluating question

Describe each segment of SCATT collected data on its interpretation for practical use.

9. WEAPON AND AMMO TESTING

To understand the basic needs for weapon/ammunition testing, it is necessary to say a few words about different types of ballistics.

There are three types of ballistics: internal, external and terminal.

Internal ballistics are studying processes that are happening inside the barrel of a weapon from the moment the firing pin hits the primer to the time the bullets exits the barrel. It is mainly concerned with propellant pressures, acceleration of the bullet whilst it is in the barrel, muzzle velocity and recoil. It is also including primer ignition time, primer pressure/time curves and temperature within the barrel.

External ballistics are dealing with the flight of the bullet from the muzzle of the weapon to the target. Various parameters affect the trajectory of the bullet, such as bullet shape, sectional density, atmospheric pressure and in larger-calibre weapons, the rotation of the earth.

Terminal ballistics deals with the behaviour of the missile once it reaches the target. In our sport this is not a concern as we are dealing with paper/rubber targets.

On the informative level let us elaborate the effect of the earth's gravity as a constant. For this purpose, we will be referring to the equatorial sea level average of 9.8 meters per second, each second. The moment the bullet leaves the barrel, two forces begin to act to decrease range and velocity. Gravity will pull the bullet toward the earth's surface and resistance caused by the air density. Bullets that move at a higher velocity, about 320–335 meters per second are supersonic, which is often the case in ammunition selection in our sport. Those speeds a shock

wave will be produced which is responsible for decreasing forward velocity more than the atmospheric drag.

With the help of thermal imaging, the temperature of the surface of the bullet when leaving the barrel is up to 260°C, depending on the ammunition used. Most of that heating is generated by friction with the barrel, partly due to the exposure to the propellant gases. A smaller part is from the heat generated by deformation as the bullet engraves to the rifling. Another small part is from friction and compression of the air ahead of the bullet in the barrel. Since the internal ballistic heating is only to the surface of the bullet that has very small thermal mass, so the overall temperature of the bullet will decrease quickly as that heat is conducted into the core of the bullet.

Due to the copyrights, it is not possible to display the photos, regarding bullet heating, so please visit the following link:

<https://www.google.com/imgres?imgurl=https%3A%2F%2Fthumbs.dreamstime.com%2Fb%2Fbullet-fired-gun-isolated-black-61923738.jpg&imgrefurl=https%3A%2F%2Fwww.dreamstime.com%2Fillustration%2Ffired-gun.html&tbnid=LdAOlwySbk9AmM&vet=10CAMQxiAoAGoXChMI8MvbhuKQ7AIVAAAAAB0AAAAAEAI.i&docid=NY-9qEpQ9BY3YM&w=800&h=519&itg=1&q=firing%20the%20pistol&hl=en&client=safari&ved=0CAMQxiAoAGoXChMI8MvbhuKQ7AIVAAAAAB0AAAAAEAI>

The need to match the barrel of the pistol with the best quality outcome ammunition is a matter of necessity for every elite shooter. Not only is the physical precision of the group a matter of compulsion, but there is also a need to establish the mental confidence of the shooter in the weapon.

As far as SP & RFP is concerned, the need for a quality barrel is vital for superior results. Weapon and barrel manufacturers can often recommend barrels with good, special properties. These types of barrels are tested with different types and qualities of ammunition, and they can show satisfactory results in grouping hits for several types and series of different ammunition manufacturers. Specially selected barrels generally show good groupings only with a certain type of ammunition. Such barrels require extensive testing to find a specific batch of

ammunition, which by its characteristics best suits the shooter. The diameter of the group must not be the only parameter based on which the selection of ammunition is made. Depending on the manufacturer, ammunition can have a shorter gunpowder burning time, causing stronger and more obvious recoil, often with higher output speed. Opposite, ammunition that has slower combustion and relatively lower output speed, will also have softer recoil. The choice between two ammunition products fx. will depend on the output speed of the bullet, recoil power, and personal preferences of the shooter.

Due to the economic effect, it is very important to find training ammunition with similar characteristics and satisfactory grouping parameters, as in the selection of excellent, competitive ammunition.

In situations when ammunition is chosen for mass use, especially for the needs of clubs, their primary option is for ammunition that has the most common group when using serially produced barrels without special characteristics, as it is the case with elite shooters.

As for ammunition for air pistol, pellets can be selected with different diameters, profiles, and weights. The selection of pellets is made based on similar parameters as ammunition for SP and RFP. The grouping of shots and the output speed are dominant factors in deciding the selection of pellets for each individual shooter. Various gun manufacturers construct their products indicating the optimal pellet speed range for their models. These parameters must be taken into account to provide the best possible conditions for the correct performance of the pistol.

To conduct proper testing of weapons whether it is a caliber .22 - 5.6mm (SP and RFP) or an air weapon caliber .177 - 4.5mm, it is necessary to know the elementary behavior of the weapon barrel. The barrel has its resonance, like strings on the guitar. The resonance of the barrel, among other things, will determine the diameter of the group of shots.

When firing the shot, the barrel is expanding in a sinusoidal manner. It would be optimal for the sinusoidal expansion to be in the zero position at the end of the barrel, but this is not the case with different types of ammunition, even when the same type of product is used. At a .22 caliber, the resonance can vary from batch to batch.

In theory, it is possible to achieve a sinusoidal zero position by registering the frequency of the sinusoid and then shorten (cut) the barrel at the desired location. Of course, this is not effective in daily life.

Another way is to select ammunition that produces a sinusoidal expansion of the tube with a zero point at the end of the tube. In practice, the second model is generally accepted, although many are unaware of this due to the lack of knowledge regarding the theory of barrel resonance.

There is a third way, changing the resonance of the barrel by adding counterweights on the barrel. The closest explanation would be a comparison of playing the guitar, a different tone is produced by pressing the strings in different places on the neck of the guitar.

Before conducting weapon testing, testing equipment should be selected. It has to be one that provides the closest possible characteristics like when a shooter shoots from a hand. It would be very wrong if barrel is clamped in the device, as it would make it impossible for the barrel to have its specific resonance during testing. Probably the shot grouping would show a small diameter, but it would be an artificial result. When the shooter takes the weapon to the shooting range and fires on the target, the most likely grouping will be much different, thus diminishing the expected result outcome. There is a range of various testing equipment and one should be careful when making decisions which one to use.



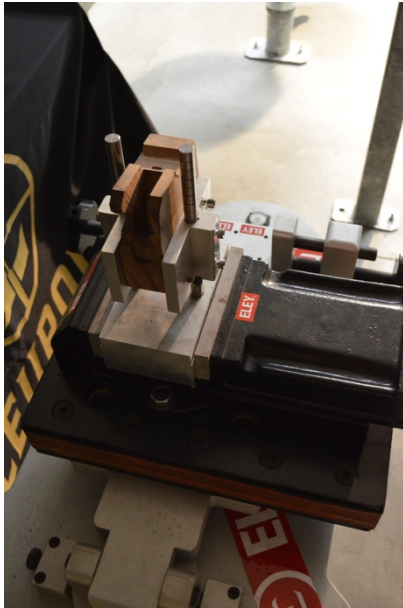

Twenty years ago, I came to an idea to construct versatile testing equipment that can be used for both pistol and rifle, regardless of the gun manufacturer and caliber of ammo that is tested. Together with a group of shooters and mechanic

engineers we constructed and extensively tested this product, before handing it out to Eley company for further use. Today it is used in many countries around the world, mostly in sophisticated testing facilities.

Before conducting the testing of firearms, like SP and RFP, guns should be meticulously cleaned. After setting up the pistol in the testing device, the first ten shots should be fired to remove possible traces of cleaning adhesives and lubricants. The test itself is conducted by shooting 10 rounds of the selected batch, recording the size of the group diameter and speed of the bullets. One should test as many necessary/available batch numbers until finding the desired group/diameter combined with speed consistency. Once the ammunition batch is selected, the same should be tested for fifty shots grouping. If the result is satisfactory, we can state that we found the desired ammunition. But this is not the end of the test. It would be advisable



to find ammunition suitable for different outside temperatures as well if possible, as well as finding cheaper ammunition batch for training purposes.

Testing air pistols is conducted similarly. The barrel has to be clean, the gun positioned in the testing device, fired 10 shots for obtaining "normal" barrel conditions before actual testing.

Measuring speed is mandatory. Once the desired pellet batch is selected, the precision of the pistol in the future will exclusively depend on the cleanness of the barrel and the speed of the pellet. Therefore, shooters should measure the speed of the pellets at least once a month.

Earlier, I was mentioning the resonance of the barrel, and here is an example of air pistol testing with the use of the 15 gr counterweight on the end of the barrel showing different outcomes.

The first picture represents "zero" testing conditions. The second and third are done with the same batch number, with slightly increased speed, and the fourth and fifth are with different batch numbers.

Test 1



Pistol: Steyr LP10
Pellet: H&N 8934
Avg speed: 169,11 m/s
Diameter: 8,0 mm
Note: no counterweight



Pistol: Steyr LP10
Pellet: H&N 8934
Avg speed: 174,63 m/s
Diameter: 10,5 mm
Note: with counterweight



Pistol: Steyr LP10
Pellet: H&N 8934
Avg speed: 174,63 m/s
Diameter: 7,0 mm
Note: no counterweight

Test 2

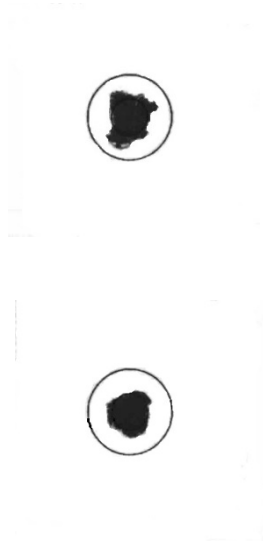

Pistol: Steyr LP10
Pellet: H&N 7298
Avg speed: 163,92 m/s
Diameter: 8,5 mm
Note: with counterweight

Pistol: Steyr LP10
Pellet: H&N 7298
Avg speed: 163,92 m/s
Diameter: 8,5 mm
Note: with counterweight

It is obvious that the change of the speed and barrel resonance have a visible effect on grouping diameter.

Self-evaluating question

Describe the influence of the barrel resonance on shoot grouping.

Describe the proper ammo testing process.

BIBLIOGRAPHY

Anatal, L & Skanaker, R. (1985) "Pistol Shooting" Ljungbergs Boktryckeri AB. Klippan, Sweden

Yur' Yev, A. (1973) "Competitive shooting – techniques and training for rifle, pistol and running game target shooting". English translation edited by Gary L. Anderson. National Rifle Association of America.

Anatal, L (1989) "Competitive Pistol Shooting" 2nd Ed. A & C Black. London.

Lozsan, A. (1997) "A shooter's guide to pistol marksmanship". Elite Coaching Systems. WA, Australia.

Standl, H. (1975) "Pistol shooting as a sport" English translation, Kaye & Ward Ltd, 1975 Whitstable Litho, Straker Brothers Ltd, Whitstable.

Standl, H. (1979). "Pistol Shooting" Coles Publishing Co. Toronto, Canada.

G.M. Woerlee, 2005–2020 <http://www.anesthesiaweb.org/hyperventilation.php>

Todorovic, Z. (2010) "ISSF Academy Pistol Shooting"

<https://www.google.com/imgres?imgurl=https%3A%2F%2Fthumbs.dreamstime.com%2Fb%2Fbullet-fired-gun-isolated-black-61923738.jpg&imgrefurl=https%3A%2F%2Fwww.dreamstime.com%2Fillustration%2Ffired-gun.html&tbnid=LdAOlwySbk9AmM&vet=10CAMOxiAoAGoXChMI8MvbhuKQ7AIVAAAAAB0AAAAAEAI..i&docid=NY-9qEpO9BY3YM&w=800&h=519&itg=1&q=firing%20the%20pistol&hl=en&client=safari&ved=0CAMOxiAoAGoXChMI8MvbhuKQ7AIVAAAAAB0AAAAAEAI>

<https://www.ncbi.nlm.nih.gov/pmc/articles/PMC5364142/>