

---

# 1 Instrumentation and Allied Technology for Endoscopic Surgery

A. MELZER, G. BUSS, and A. CUSCHIERI

## Introduction

The instrumentation for endoscopic surgery has increased substantially since 1989 when the first laparoscopic cholecystectomy was performed; however, the instruments and the technology have not advanced significantly from the original devices designed and developed by Jakobeus [1], Wittmoser and Pfau [2], Semm [3] and our teams [4, 5]. Although trocars, cannulae, needle holders, scissors, forceps, and clip and stapler systems have been refined the basic technical problems of endoscopic surgery have not been overcome [6]. Sutures, ligatures and difficult organ dissections have to be executed with rigid needle holders, external slip knots and unergonomic handles across a two-dimensional operative field. Thus, complicated endoscopic operations can only be conducted safely by experienced surgeons. These procedures will be facilitated if the present disadvantages and limitations of endoscopic surgery technology due to restricted handling of tissue, lack of tactile sensation and force control are resolved [7] and three-dimensional vision is established routinely [8]. More complex and exacting procedures require even more intricate and delicate instrumentation. It is important that the surgeon become familiar with engineering and technological principles because he is the one who has to address the technical operative problems. Aside from the need for instrument development, certain basic medical and surgical principles must be followed. These include adequate operating times, completely sterile equipment, minimum malfunction and uncompromised patient safety. In this respect it is important that we encourage the industry and engineering departments to co-operate with surgeons in order to produce the instrumentation which meets the needs of endoscopic surgery.

## Developmental Principles

Historically, physicians and technicians have worked closely to develop surgical instruments. Although these instruments were relatively primitive, they incorporated the necessary design features for good function using the manufacturing processes available at that time. Over the past centuries numerous instruments have been made [9]. Some were modified and then discarded, according to the progress in surgical science and current knowledge [10]. The conventional instruments of open surgery have obviously stood the test of time and over the years have been perfectly adapted to their purpose. But this tradition of instrument development and processing amongst surgeons and technicians has been interrupted and in past years the initiative has been taken over by industry.

### New Area of Surgery:

### Old Principles of Development

Endoscopic surgery reveals the limitations and fundamental problems of current instrumentation. In this respect, the close co-operation between the engineer and the surgeon is assuming more importance, and so, as in the past, they must join effort to utilize all the available technological advances to produce the instrumentation which is best suited for the operations. Endoscopic surgery requires new instrumentation, e.g. instruments which are steerable, multifunctional, with automatic suturing, etc. Our goal has been to create the required tools by appropriate design [11]. As in former times, the instruments are designed by both the surgeon and the technician. This interdisciplinary linkage has revealed an important advantage; while

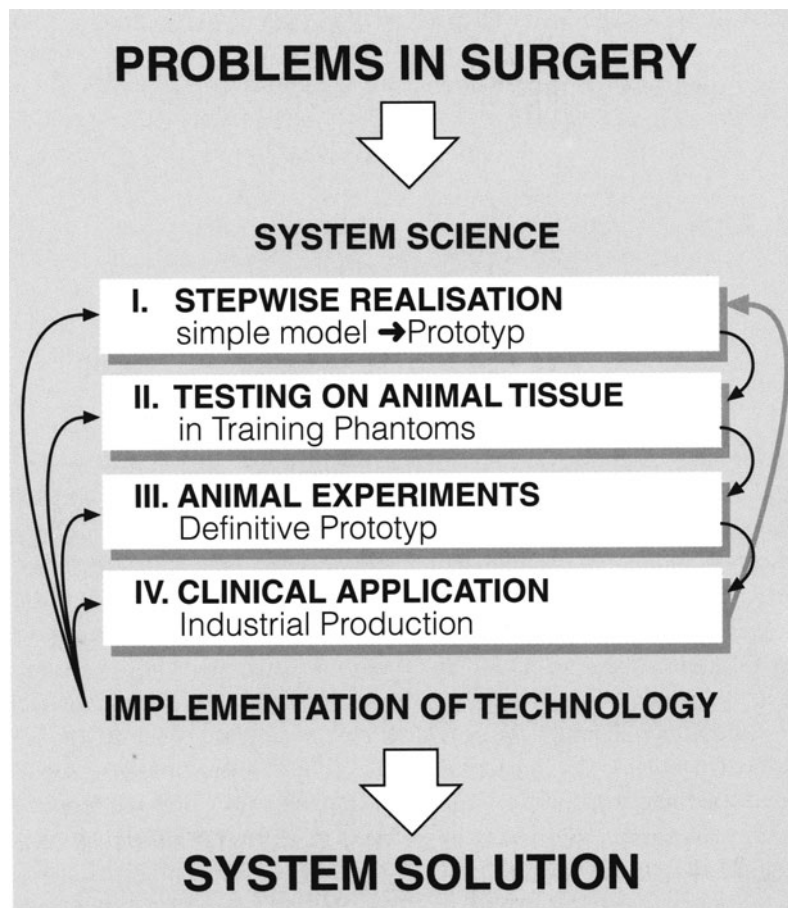

the surgeon is learning some important rules of design and principles of construction, the technician is acquiring knowledge concerning basic surgical and medical principles [12, 13].

### Interdisciplinary Co-operation

We have established an interdisciplinary team concerned with the development of endoscopic surgical technology. This team always operates with a specific goal according to the principles of the co-operative model, which is divided into two levels:

- Level 1 entails the development of simple instruments and devices in consideration of practical surgical requirements for endoscopic operations.
- Level 2 includes system research [14] of endoscopic surgery as the cornerstone of the development of advanced, intelligent instrumentation and operating systems.

**Fig. 1.1.** Innovation level 1 in technology development for endoscopic surgery.

The developmental process is subdivided in four phases: first phase (*I*): theoretical solutions and simple models; second phase (*II*): practical approval of ideas in phantom experiments on animal tissue; third phase (*III*): animal experiments and professional manufacturing of prototypes; fourth phase (*IV*): clinical tests and industrial production. All sections of the development are interconnected and thus influenced and controlled by each other, not necessarily proceeding from phase 1 to phase 4. Ideas can be realized in all phases depending on their technological complexity or the medical approach

The development in level 1 is governed by the surgical problem and consists of four phases (Fig. 1.1). These phases are interconnected and influenced by current technologies as well as system analysis and techniques.

In *phase one* the surgeon and the technician discuss and outline a number of theoretical solu-

tions regarding the instrument with sketches, drawings and simple wire or wooden models.

*Phase two* includes the crafting of simple prototypes, for example by modifying conventional instruments and creating test phantoms using animal tissue. At this stage the options are reduced to those which appear promising at the initial testing and only these are processed in the next phase. Whether engineers are involved in the theoretical calculation and design depends on the devices which are planned. The industry has to be involved early to consider processing, serial production and marketing.

In *phase three* the prototype is designed, manufactured and tested, first in phantoms and then in animals. Further modifications can be made in a workshop close to the animal lab. The practical experience gained by the use of the instrument in animals often requires that an instrument be redesigned.

In *phase four* a real prototype of the final instrument is manufactured by a medical instruments manufacturer. Only a device which has been successfully tested in human surgical procedures should reach the market for routine clinical application. However, reliability and clinical value of the solution only becomes apparent after an instrument has been used routinely. Not seldom, medical progress in other fields competes with or outmodes the operation itself.

This model is flexible; there are no fixed demarcations between the phases. The very first prototype of a simple instrument, for instance, can reach the routine usage phase and, by contrast, more complex developments such as manipulators or multifunctional instruments [7] may require processing through all the phases plus extensive testing and modification.

Level 2 entails systems research [14] and the development of intelligent instrument systems. The next generation of instruments will be intelligent steerable instruments equipped with microsensors, actuators [7, 15] and complex electronic controlling systems. The development of such instrumentation is, indeed, difficult and specific research must be conducted e.g. on qualification of tactile and proprioceptive impulse transmission [16, 17] or microsensor and actuator systems to achieve appropriate remote handling under three-dimensional endoscopic vision. Such delicate developments re-

quire the whole spectrum of scientific engineering. Therefore we are collaborating with research teams from the Nuclear Research Centre, Karlsruhe (KfK) Germany, the Fraunhofer Society, St. Ingbert, Germany, and the German Aerospace (DASA), Munich, Germany. The design and testing may be enhanced by simulating and modelling tools. In current microsystem engineering, computerized check of the design is indispensable [15]. The engineer proves and tests his development repeatedly to eliminate instrument failures. Such quality assurance and error analysis in endoscopic surgery will provide more reliable instrumentation. Even so, there is still the need for final experimental and clinical evaluation, because in surgical practice, instrument performance during actual operations is what ultimately determines its usefulness. It is important that the surgeon become more familiar with engineering principles and technological science, because he is the one who has to address the technical problems and to indicate the ways of resolving them. Hence, one of our most important aims is to create useful interdisciplinary co-operation in the future which requires that both groups be able to understand a certain basic language<sup>1</sup>.

## **Technological and Medical Considerations Governing Safe Endoscopic Instrumentation**

### **Reliability**

Spatial restrictions put limitations on the design and construction of reliable and safe endoscopic instrumentation. Multifunctional devices are especially delicate and susceptible to breakage, and so cleaning and sterilization can damage instruments [18]. Besides the financial aspect, breakage and loss of a jaw, for instance, while clamping a vessel, is unacceptable and can cause complications. The paramount problem in technical design, though, is the narrow calibre and the length of the instruments. Critical constructions with hinges and small

---

<sup>1</sup> A new journal, *Endoscopic Surgery and Allied Technologies*, has been established to provide a forum for interdisciplinary communication, for example.

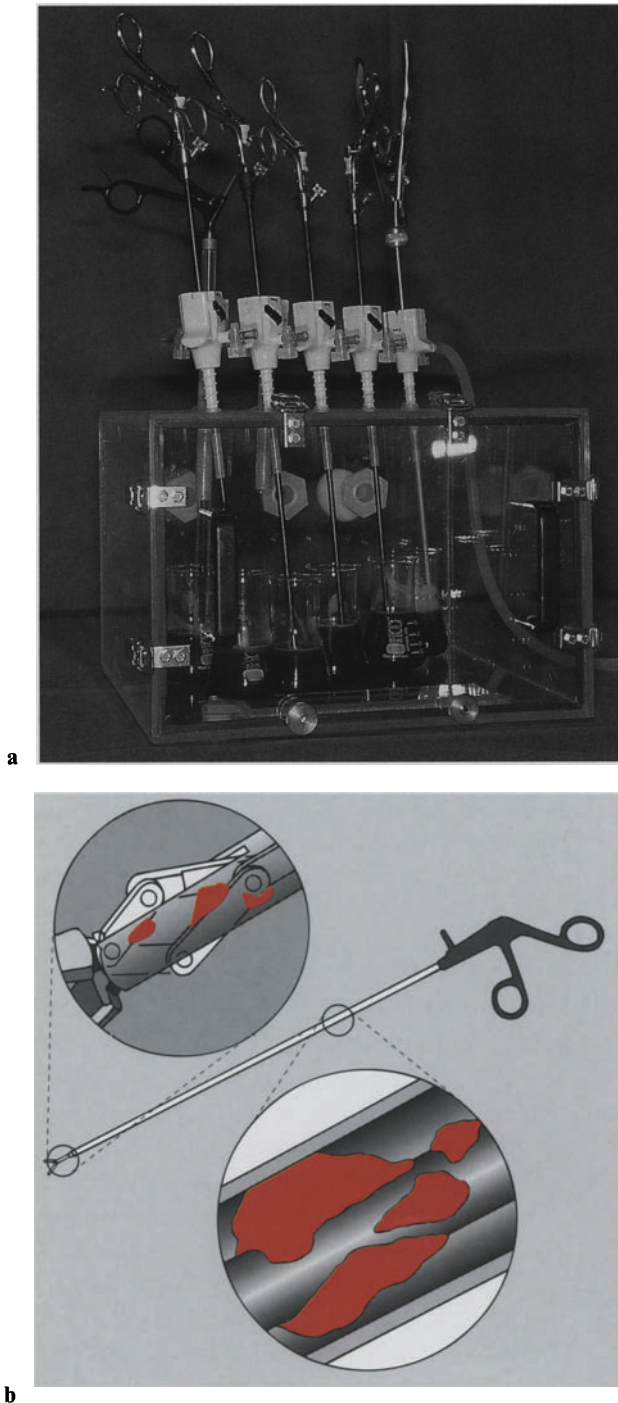

**Fig. 1.2 a, b.** Problems in cleaning endoscopic instruments. **a** Samples of standard instruments were placed in a simulator box in order to examine their cleanability (Tübingen). **b** Because of the tube character of the long instruments, the capillary gaps at the jaws and handle in conjunction with the intra-abdominal pressure become considerably stained with blood, which remains after routine work

bolts (Fig. 1.2) must be re-designed in order to achieve a simple and reliable action system which is simple and safe to use. Disposable instruments may solve some of the problems. They are completely sterile and the minimal lifetime requirement ensures in part appropriate function, e.g., scissors are sharp. However, the functions are often not as precise and optimal as required. Grasping forceps are sometimes unsuitable and the precise action of the jaws reduced because of instability and hysteresis of grip and hinges. Various considerations may require reduction of production costs, especially the desired low sales price. Thus either the design or the variety of construction material may affect instrument function and reliability.

In order to reduce the costs incurred in endoscopic surgery by disposables “re-posables” or semi-reusable instrumentation should be designed which meets the requirements for both endoscopic surgery and hygiene [19]. The functions should be controlled as easily as possible so that surgical procedures can be performed precisely and quickly. In addition, easy and fast sterilization and reprocessing must be possible without significant loss in reliable function and lifetime of the instrument.

The parts which are subject to excessive wear and tear or which are too delicate to undergo the work-up can be disposed of, and the function of reusable parts frequently and regularly checked, preferably by specialized staff.

### Applicability

#### Disinfection and Sterilization of Endoscopic Equipment

Hygienic requirements for instruments and equipment depend on the likelihood of contamination and subsequent infection in the patient. There are three risk levels [20]: Highly critical are those instruments exposed to the patient’s blood or tissue, semi-critical are those exposed to mucous membranes, and noncritical are those only in contact with the skin. For these different levels, different reduction rates of micro-organisms are mandatory. For high-risk instrumentation a microbe reduction of  $10^6$ , including spores, is necessary and for semi-critical equipment  $10^5$ , excluding spores.

If an instrument is exposed to the organs and possibly to the blood in endoscopic surgery it must be treated as a highly critical item. Cross-contamination and subsequent infection must be avoided by completely cleaning and subsequently sterilizing the instruments. The optimal sterilization process is autoclaving. However, 121 °C–134 °C pressurized and saturated water steam can severely damage heat-sensitive instruments made of plastics or optics and electronic devices. The explosive and toxic, ethylene oxide (EO) is used for low-temperature sterilization of heat-sensitive materials. The EO process requires delicate machinery and safety considerations and is less effective than steam processing. Prior to use the instrument has to be exposed to air to reduce the gas content. This airing time is up to 1 week for plastic and 24 h for metal. Thus the minimal time for an EO cycle is 1 day [21].

The low-temperature “sterilization” of the instruments using Sidex or other solutions such as glutaraldehyde, formaldehyde or peracetic acid is suitable for disinfection for semi-critical instruments but of limited value for instruments exposed to tissue and blood and cannot be recommended. There have been a few cases of proven transmission of HBV infection caused by endoscopic systems [20]. However, it is hardly possible to follow such infection pathways, and absence of evidence of infection does not mean there is no risk of infection. Hence, instruments must always be sterilized.

Newly developed methods of low-temperature sterilization can completely sterilize even delicate and temperature-sensitive systems [22]. The Sterrad System (Johnson&Johnson, Norderstedt, Germany) is a H<sub>2</sub>O<sub>2</sub> low-temperature plasma process which allows nontoxic, rapid sterilization at temperatures not above 50 °C [23].

The process proceeds in the following manner: The instruments are sealed in a special package and placed in the plasma chamber of the device and a vacuum created. Approximately 1.8 ml H<sub>2</sub>O<sub>2</sub> are injected into the chamber. The H<sub>2</sub>O<sub>2</sub> immediately vaporizes due to the vacuum and all instruments are contacted. A radio-frequency, high-voltage field is generated and breaks down the H<sub>2</sub>O<sub>2</sub> molecules into free radicals. These react with organic materials and thereby destroy micro-organisms. The whole cycle (ca. 75 min) is completed by refilling the chamber with filtered air.

Low-temperature plasma sterilization is limited primarily to surface sterilization; however, electronic equipment, in particular, synthetic materials can be sterilized and no airing is required. In addition, no special building or construction work is required in the clinic because the system is only the size of a large cleaning machine.

#### Basic Rules of Disinfection, Cleaning and Sterilization

The principle rule of work-up is disinfection, cleaning and subsequent sterilization. Cleaning and disinfection is usually a combined process. It must be possible to wet all surfaces of the instrument to adequately flush and rinse it [19]. Frequent tests of sealing are mandatory since the instrument cannot be disassembled after it has been sealed.

Preliminary results of our investigations in Tübingen indicate that cleaning facilities for standard-design, rigid, reusable endoscopic forceps and scissors are inadequate (Fig. 1.2b). Therefore, we have developed in co-operation with Netzsch Newamatic (Waldkraiburg, Germany) and Jakoubek (Liptingen, Germany) the Tübingen container (Fig. 1.3a). After surgery the nurse places the instrument, disassembled if required, in this container and connects all tubes to special interfaces. The contents of the container are automatically cleaned and thermally disinfected, as usual. All internal surfaces of the instrument are reached by measuring the irrigation flow through all channels. The same container is then returned to the operating theatre and the scrub nurse can reassemble the instrument for the next operation. Thus, direct contact with contaminated instruments which are usually inadequately cleaned and scrubbed by hand can be minimized. Not only in consideration of recent identification of HIV virus in blood aerosols during surgical procedures [24] hand cleaning should be abolished totally.

Cleaning and disinfection depend more on the design of the instrument than on the washing machines because those have stood the test of time and their cleaning properties have been confirmed and are reliable for existing traditional instruments. Although the Association of Operating Room Nurses (AORN) strongly recommends the disas-

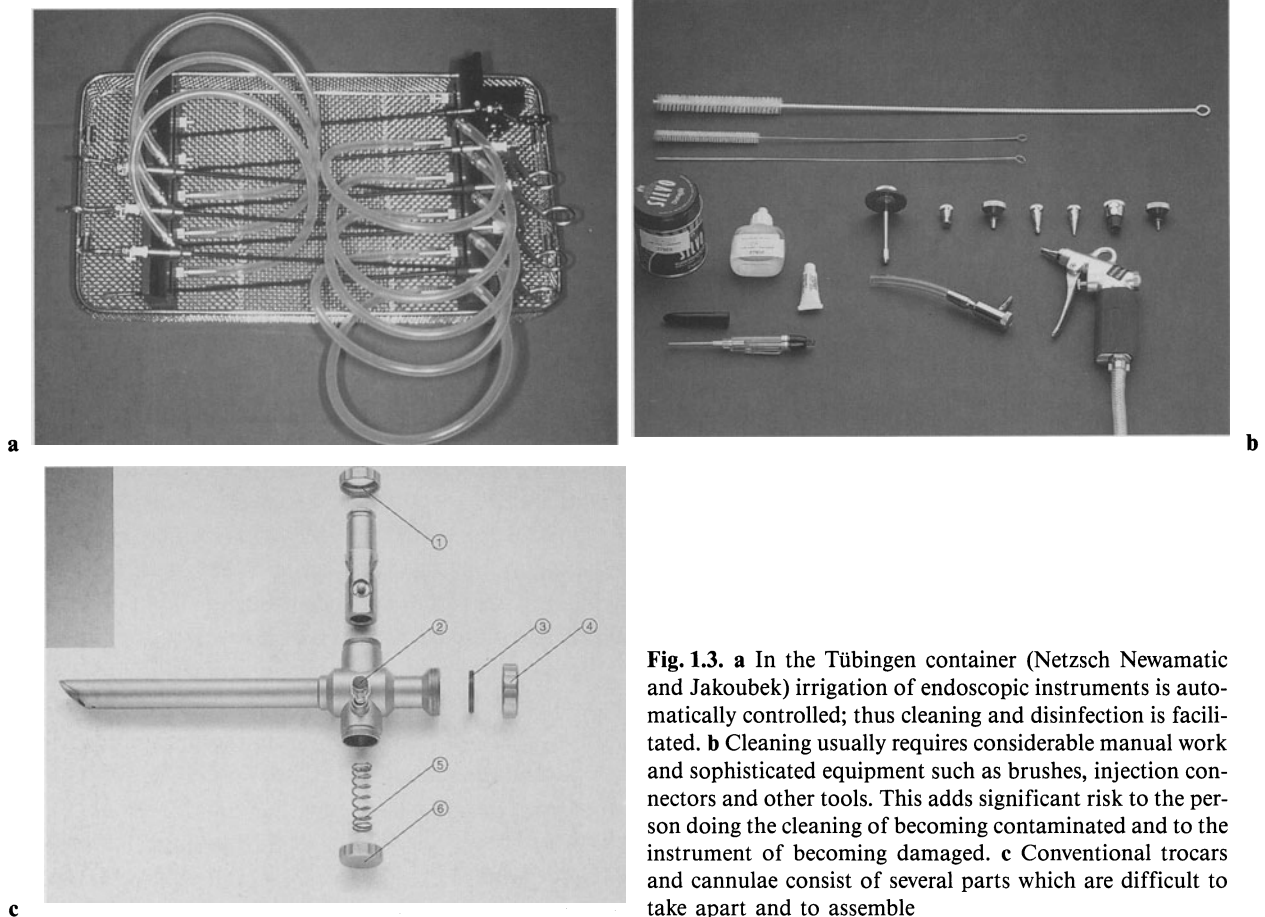

**Fig. 1.3.** **a** In the Tübingen container (Netzsch Newamatic and Jakoubek) irrigation of endoscopic instruments is automatically controlled; thus cleaning and disinfection is facilitated. **b** Cleaning usually requires considerable manual work and sophisticated equipment such as brushes, injection connectors and other tools. This adds significant risk to the person doing the cleaning of becoming contaminated and to the instrument of becoming damaged. **c** Conventional trocars and cannulae consist of several parts which are difficult to take apart and to assemble

sembling of all surgical equipment for sterilization [25, 26], endoscopic instruments can only rarely be efficiently and easily disassembled. Disassembled instruments are easier to clean and to sterilize [27]; however, the cleaning requires a considerable amount of work by hand and equipment (Fig. 1.3b). Conventional cannulae, for example, consist of several parts which are difficult to take apart and to assemble (Fig. 1.3c). We have attempted to develop instruments which can be easily disassembled and re-assembled while maintaining appropriate and reliable functions. The first prototypes of hingeless modular instruments designed and constructed in collaboration with PCI/Jakoubek (Lip-tingen, Germany) and Nitinol Devices and Components NDC (Fremont, CA, USA) are promising (Fig. 1.4a). Other manufacturers such as Storz (Tuttlingen, Germany) or Wolf (Knittlingen, Germany) are marketing instruments which can be disassembled (Fig. 1.4b).

The industry should be encouraged to supply the surgeon with suitable, practical equipment which also meets the requirements for hygiene and work-up. Therefore, norms and standards must be established for endoscopic instruments<sup>1</sup>.

The solution to these problems may be to replace reusables with disposables, but this would be of unacceptable expense. In our view the use of disposables should be restricted to certain instruments, such as staplers and other delicate ones. The shaft, handle and other simple parts should be reusable. The use of disposables leads to another important problem, that is reprocessing and reuse of disposable instruments, which seems to be practised in a number of hospitals. This policy is critical, because the manufacturers guarantee the function of their devices for the first use only. If the in-

<sup>1</sup> A committee to develop DIN standards for endoscopic surgery was founded in September 1993.

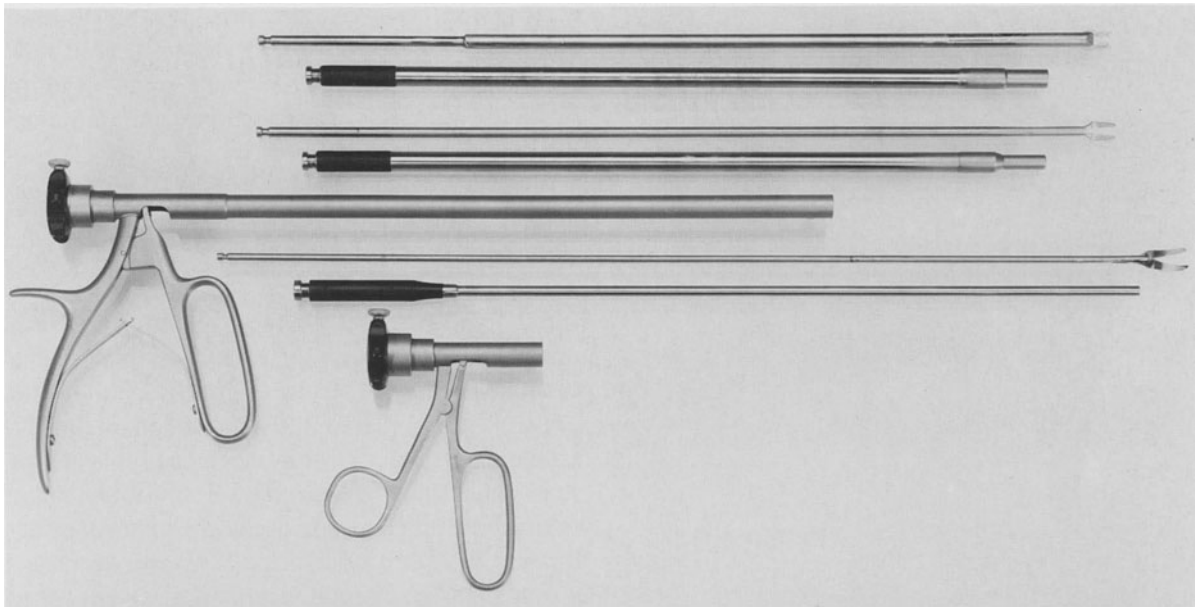

a

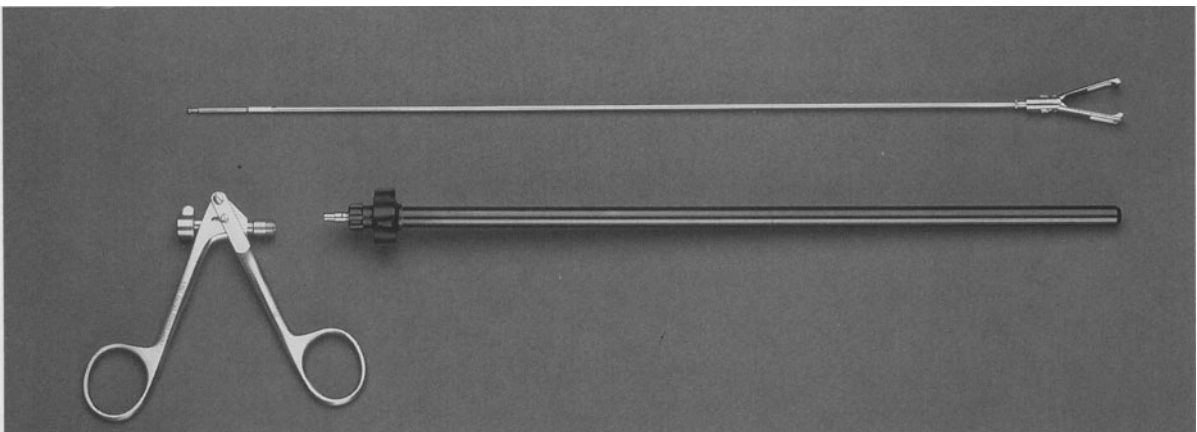

b

**Fig. 1.4. a** A new generation of hingeless modular instruments designed and constructed together with PCI/Jakoubek and Nitinol Devices & Components NDC can be easily disassembled and cleaned. **b** Storz, Wolf and other manufacturers are marketing standard hinge instruments which can be “taken apart” to facilitate cleaning

strument breaks subsequent to reprocessing, the surgeon is fully responsible for any resulting hazards [19]. We have only used reprocessed disposables in experimental surgery in animals and according to our experience the life-time of such instruments is often reduced after work-up and sterilization. However, cost-efficiency studies must be performed. Economical and ecological principles

such as waste, energy, material and labour also need to be intensively investigated in order to find the optimal endoscopic instruments.

### Biocompatibility

Biocompatibility is an important restriction in the design of endoscopic instruments as regards construction material, sealing grease and oil. The material has to meet certain requirements: no toxic effects to tissue, minimal tissue reaction, maximum chemical resistance to chemical influence, etc. [28]. The materials suitable for instruments must be of high mechanical quality. However, mechanical stability is inversely proportional to biocompatibility.

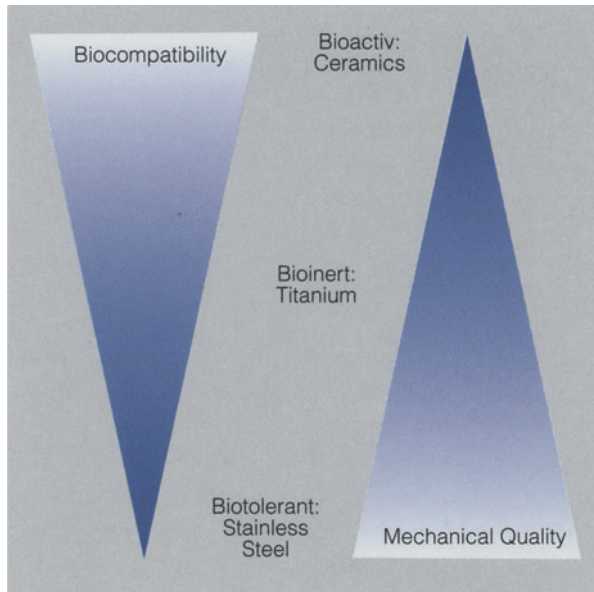

**Fig. 1.5.** Schematic illustration of the relationship between biocompatibility and mechanical quality of materials. The higher the level of biocompatibility of the material the lower the mechanical stability. For example, ceramics are bioactive materials, which means that the surface of the ceramic is either covered by a layer of protein molecules or it is actively integrated within tissue formation (calcium hydroxy dissolution apatite in bone). But their elasticity and mechanical stability is low. The bioinert materials such as titanium form passive oxide layers that protect within the human body. The biotolerable materials, such as tantalum and stainless steel, provide high stability, minimal tissue reaction and acceptable rate of dissolution of contents

Synthetic materials must be processed under clean conditions, e.g. the content of heavy metal must be kept to a minimum. Biodegradable plastics are preferable for clips and other implanted materials; however, their spectrum of processing is limited, there are fewer manufacturing facilities available and the mechanical stability is reduced compared to metal. Figure 1.5 illustrates the level of biocompatibility of common materials used in medical equipment.

## Imaging Principles

Due to reduced sensory input such as loss of tactile feedback and the two-dimensional video image, the endoscopic surgeon requires additional anatomical

information. Hence, angiography, ultrasound, computed tomography (CT) and magnetic resonance imaging (MRI) [29–35] are employed to improve the appraisal of the anatomy and pathology of the operative field.

## Intraoperative Cholangiography

Intraoperative cholangiography is not a new technique. Since it was introduced by Mirizzi and advocated by Hickens in 1936 [30], its routine use is still under discussion and the application in laparoscopic cholecystectomy has heightened this controversy [31, 32]. The editors, however, recommend its routine use during laparoscopic cholecystectomy, because there is no substitute diagnostic technique which yields comparable anatomical detail. Moreover, the surgeon who is not practised in performing routine intraoperative cholangiography will not progress to more complicated procedures. The quality of cholangiography depends on the radiological equipment and its competent use [30].

Mobile X-ray machines with three blind exposures during and after the injection of different amounts of contrast are unsuitable and yield poor results. In addition, the important filling phase during contrast injection is missed. Due to such mishaps the procedure has to be repeated frequently and is time consuming. With the modern C-arm imaging systems (Fig. 1.6) with digital enhancement software such as real-time subtraction, road mapping modes and image storage provide excellent high resolutions exposures [33] (OEC Diasonics, Salt Lake City, UT, USA; Philips Medical Systems, London UK; Siemens, Erlangen, Germany). Using digital real-time subtraction angiography (DSA) with intravenous contrast injection, arteries can be visualized, obviating the need for direct arterial puncture. Unwanted background information is “subtracted”, leaving only an image of the contrast-filled vessels, which is the difference between the “mask image” obtained at the start of subtraction and the contrasted exposure. When employed during intraoperative cholangiography, DSA is of particular benefit because it reveals additional anatomical details which can be obscured by overlapping structures. All the state-of-the-art C-arm machines support the subtraction technique.



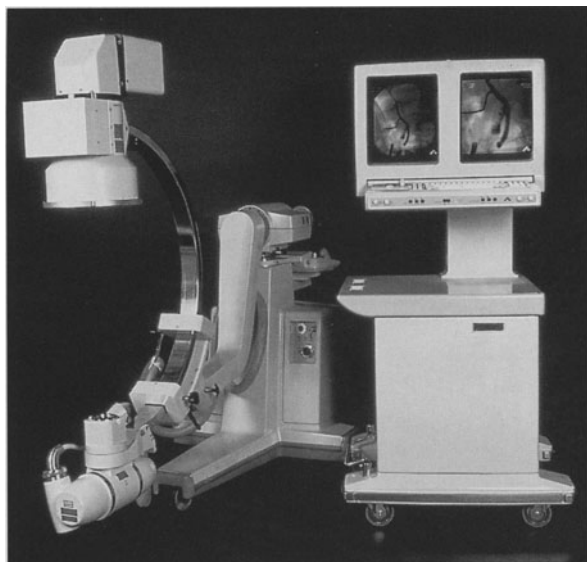

**Fig. 1.6.** Digital C-arm imaging systems provide superb exposures owing to new functions such as real-time subtraction, road mapping modes and image storage (OEC Diasonics, Philips Medical System, and Siemens)

The zoom, activated on the trackball panel, allows two- or four-fold magnification of a selected area of interest. “Peak opacification” compares the darkness of all pixels subsequently and replaces previous pixels by the darkest pixels acquired during the imaging process. By means of an automatic equalization of the contrast the “autohisto” takes a sampling of grey-scale values of the image and determines the correct level of an optimized and sharp exposure. The resulting image shows an optimum of contrast and quality for post-processing and image storage. The “road mapping” function obtains a sequence of subtracted images of a preselected original mask which is particularly useful for interventional cholangiography. With “real-time imaging” a selected stored image can be displayed on the left monitor and the active screening process on the right monitor. The running image can be enhanced by keeping an average of pixel values over several frames and a special feature reduces motion artefacts. It provides an average of the “noise” caused by small movements, allowing these to be viewed without undue lag. The images are stored on a hard disc, and so the surgeon can select images as they appear on the screen by means of a foot switch. These files can then be recalled and

post-processed by transmitting the data on X-ray film cassettes of a multiformat camera or as video signals in SVHS quality on tapes or if desired as video prints by means of a laser video imager.

## Ultrasound

The biliary tract and abdomen can be viewed using laparoscopic ultrasound [34, 35]. In contrast to radiological imaging, ultrasound operates on high-frequency longitudinal sound waves, which by reflection emanate an echogram of the biological tissue. The appropriate diagnostic range of the frequency (3.5–10 MHz) is obtained by a piezoelectric transducer. The size, shape and resonance frequency of the emitting silicon crystals determine the course of the sound beam within the examined tissue. To create a two-dimensional scanning field, the transducer crystal can be alternately moved within a sector of 60° up to 120°, or numerous transducer crystals linearly connected in a row are sequentially activated. The latter yields excellent resolution and a rectangular image which obviates the visual distortion of the triangular sector. The sound beam passes through the different cell layers that have different acoustic impedance which leads to attenuation of the sound beam. Attenuation is due to the loss of energy caused by reflection, refraction, divergence and absorption. The more attenuation caused by the sound through the tissue, the lower is the resultant signal intensity. The reflected sound signals detected by the receiver produce the image of the tissue texture according to the different signal intensities produced by the tissue impedance. The ultrasound image effects are “shadowing” and “enhancement”. A sound shadow occurs when the intensity of tissue (fibrous, calcification or gas) is higher than an average attenuation according to the depth of tissue, which is balanced by means of the electronic controlling unit of the imager, whereas enhancement is caused by tissue which has lower attenuation (e.g. fluid) than that of the underlying structure.

The degree of the resolution of the image in respect of the depth of the examined tissue is determined by the frequency of the ultrasound transducers. The lower the frequency, the deeper is the expo-

sure, but the degree of resolution decreases. By contrast, the higher the frequency (up to 20 MHz in intravascular scanning) the greater is the resolution, but the depth of the field is reduced [36]. For endoscopic purposes a range of 5–10 MHz seems to be appropriate. The ultrasound imaging systems are digitally enhanced and the pulse echo is converted into real-time, two-dimensional and even three-dimensional images. The contrast agents used are different from those used in radiology. Gas microbubbles in a fluid matrix provide the enhancement. However, the routine application of ultrasound contrast agents requires further research and evaluation.

### Laparoscopic Ultrasound Probes

The ultrasound probes currently available for laparoscopy are the sector scanner made by Endomedix (Irvine, CA, USA) and the Aloka linear probe (Keymed; Southend-on-Sea, UK). However Endomedix is no longer trading. The 7.5 MHz LaproScan (Endomedix) (Fig. 1.7 a, b) employs a sector of 90°, one probe in side view and one in transverse view. Although the scanning can be controlled by the handpiece, its resolution and image qualities need further refinement.

The Aloka probe (Keymed) has a linear array which consists of aligned transducer elements. Its image is of high quality and comparable to that of hand scanners. However, the array beams in a rectangular direction, which decreases its applicability [34]. A convex surface of the transducer would represent a considerable improvement. Also a deflectable and adjustable scanning position of the distal tip is adequate [35]. The paramount problem of a deflectable probe (IV-E1, Olympus Optical; Tokyo, Japan) is steam sterilization, because the technology employed is comparable to that of the flexible endoscope scanners (see Fig. 1.7 b).

### Duplex Scanning

The Doppler effect – a reflected sound wave from an object moving away from the acoustic source has an enlarged wavelength, whereas the reflected wave from an object moving towards the source has

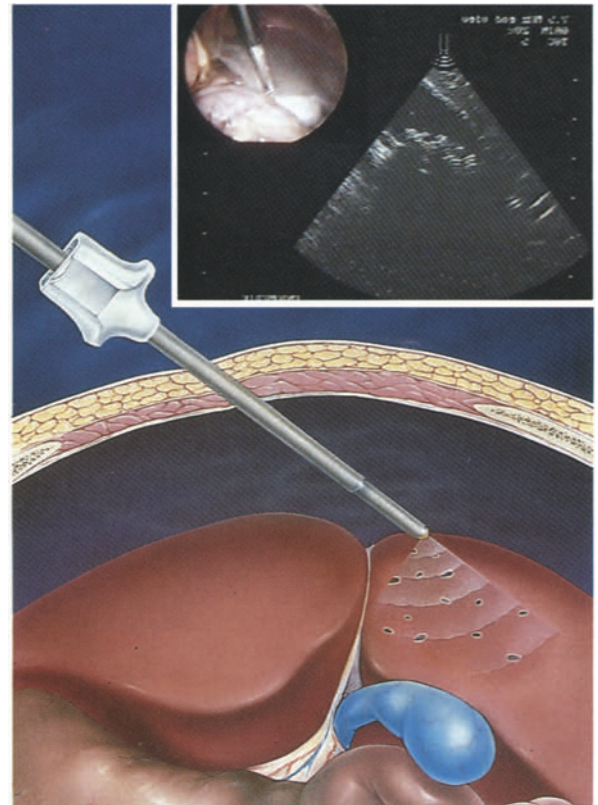

a

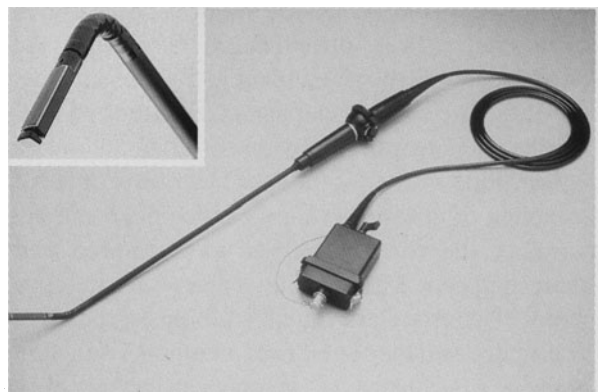

b

**Fig. 1.7.** **a** Endomedix (Irvine, CA, USA) used to market an ultrasound sector scanner which can be applied laparoscopically. Although sector scanning leads to image distortion, the scanning image can be gained from one single point. **b** A deflectable, linear sector scanner is available from Olympus Optical. The linear scanning requires a relatively large contact square to the organ; however, it produces superb images

a shortened wave length – is the principle which allows blood flow and direction to be detected and venous flow to be distinguished from arterial flow. The duplex scanning system facilitates endoscopic

dissection of structures containing large vessels in difficult anatomical regions [37, 38]. Doppler probes are available from Medasonics (Fremont, CA, USA) and Meadox Surgimed (Oakland, NJ, USA).

## Optical Systems

From the technological point of view the rod lens systems of rigid endoscopes are nearly optimized and further considerable improvement is physically limited. The resolution and colour quality of the current endoscopes corresponds to that which the human eye is able to perceive. Although distortion-free telescopes are available, distortion correction is still under discussion for monocular endoscopy. Distortion facilitates depth perception but the corrected optical system gives a better image (see Vol. 1, Chap. 2).

## Disposable Endoscopes

The latest development in rigid endoscopes is the disposable laparoscope by USSC (Norwalk, CT, USA). Although light weight, not heat conductive and equipped with a lens cleaner, the image quality is not fully adequate for endoscopic surgery. The compromise in quality is due to the cheap production required to make the price affordable. From the technological point of view, plastic lenses made of polymethylmethacrylate can yield superb image quality (Minolta photo lenses). Especially the coating with metal oxides and nanometre-size silicate particles gives plastic both excellent dereflection and scratch resistance properties which are comparable to those of glass.

However, these lenses are larger than endoscopic ones and the correction of chromatic and spheric aberrations of lenses requires different sorts of glass with different light defraction indices. Currently, plastic lenses have approximately the same light defraction index.

In future, the plasma sterilization method will make it possible to sterilize temperature-sensitive material such as plastic lenses made of polymethylacrylate routinely. In this respect the advantages of plastic lenses – light weight, reduced heat conduc-

tion and reduced risk of damage – should be considered for high-quality reusable endoscopes.

## Video Equipment

The paramount element of the image quality is the video equipment used for the operation [39]. The superb imaging quality of the telescopes are reduced by the resolution and colour quality of the cameras. The heart of the camera is the charge-coupled device (CCD) chip which is extensively described in Vol. 1, Chap. 2. The chips currently employed in endoscopic cameras are 1/2 inches diagonally. There are about 333 000 pixels and 400×400 lines; ca. 1000×1000 lines and 1 million pixels are desirable. Preliminary experience with endoscopic HDTV in Tübingen has revealed considerable advantages and enhancement of endoscopic surgical procedures due to the superb resolution 1250×920 lines and 2.2 million pixels. HDTV endoscopy will be commercialized by BTS (Eindhoven, The Netherlands) and Wolf. The minimal size of the rod lens system suitable for HDTV resolution is that of a 10-mm endoscope.

Digital video processing and recording is currently available (e.g. Canon, Sony, etc.) and holds great potential as the pictures are indefinitely stored on optic discs but current costs are prohibitively high. However, in combination with HDTV endoscopy digital video would fulfil all requirements regarding colour trueness and resolution that are necessary for adequate visualization in endoscopic surgery.

## Rigid Chip Endoscopes

The integration of the CCD chip within the tip of the endoscope seems to be of considerable advantage compared to the classic endoscope and camera system. It is light weight and easy to handle and the camera does not need to be adapted. The complete set can be sterilized so that no cover is required and the loss of light through the rod lenses and above through the connection between light cable endoscope and ocular camera can be avoided. However, resolution and colour reproduction of current CCDs are inferior to that of rigid rod lens systems.

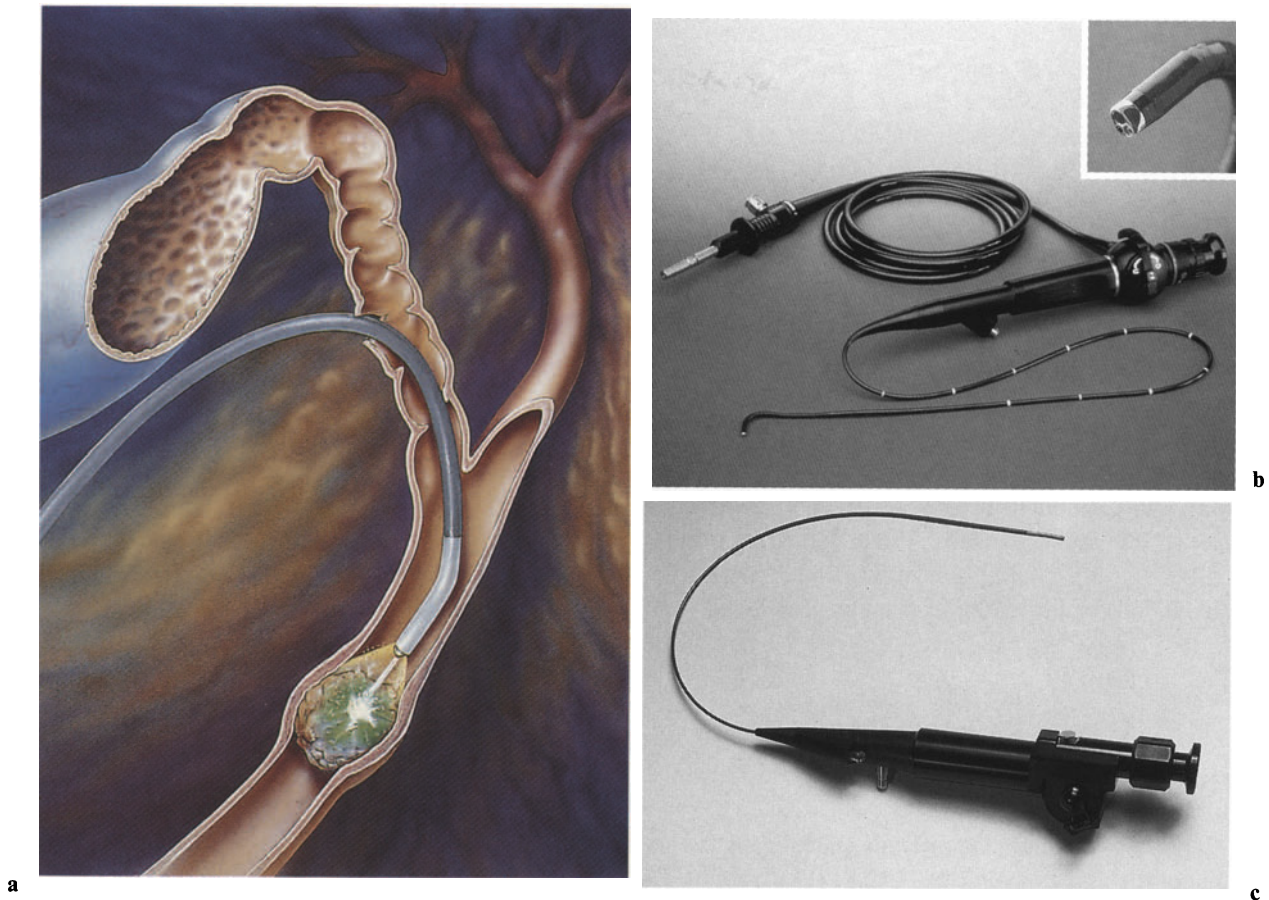

### Stereoscopes

In addition to the stereo telescope of transanal endoscopic microsurgery (Wolf) stereo laparoscopes manufactured by Aesculap (Tuttlingen, Germany) Olympus Winter&Ibe (Hamburg, Germany) and Opticon (Karlsruhe, Germany) and others are available. However, they are only useful in combination with two cameras for three-dimensional video techniques. Stereoscopes are comprised of two high-quality optical systems integrated into one tube. As high-precision optic adjustment and additional parts such as lenses and prisms are required, the manufacturing is difficult and more expensive than monocular endoscopes [40]. The two optics should be distortion-free, because this is important for a maximum correspondence of the two images.

**Fig. 1.8.** **a** Flexible endoscopes are being used increasingly in endoscopic surgery, e.g. for common bile duct exploration and intraoperative lithotripsy (Endomedix). **b** Photographic representation of a flexible choledochoscope (URF-P2, Olympus Optical). Comparable scopes are available from Storz, Wolf, Pentax and others. **c** Semi-disposable scopes (Endomedix) can be resterilized using ethylenoxide or formaldehyde a limited number of times, depending on care and handling

### Flexible Endoscopes

Flexible endoscopes are being used increasingly in endoscopic surgery, e.g. for common bile duct exploration (Fig. 1.8a). Flexible scopes (Storz, Wolf, Olympus Optical, and Pentax, Tokyo, Japan) can only be reliably sterilized by EO or formaldehyde processing which is time consuming and involves an additional risk of damage to these expensive devices. Semi-disposable scopes, (Endomedix; Fig. 1.8c) can be resterilized a limited number of times using EO or formaldehyde. The problem is

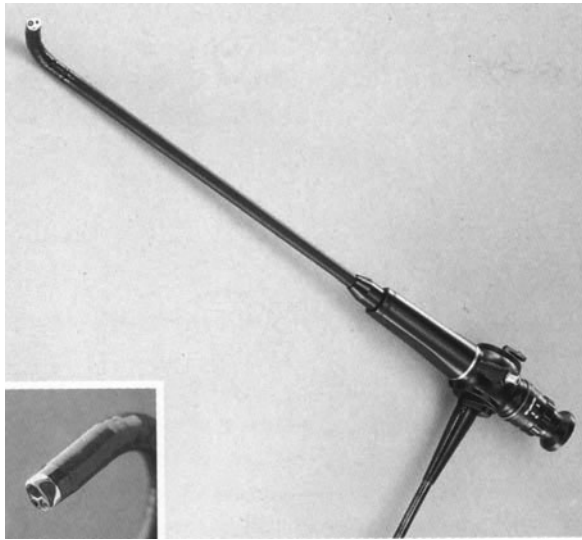

**Fig. 1.9. a** The new thoracofibrescopes have a rigid shaft but are flexible on the distal end (LTF, Olympus, Optical). Although the optical quality is inferior compared to rod lens endoscopes, the deflecting is of considerable benefit for diagnostic thoracoscopy. Schematic comparison of surgical manoeuvres using rigid (b) versus semiflexible (c) telescopes. Surgical manoeuvres are more difficult to conduct when the endoscope is deflected because the eye coordination axis is reversed

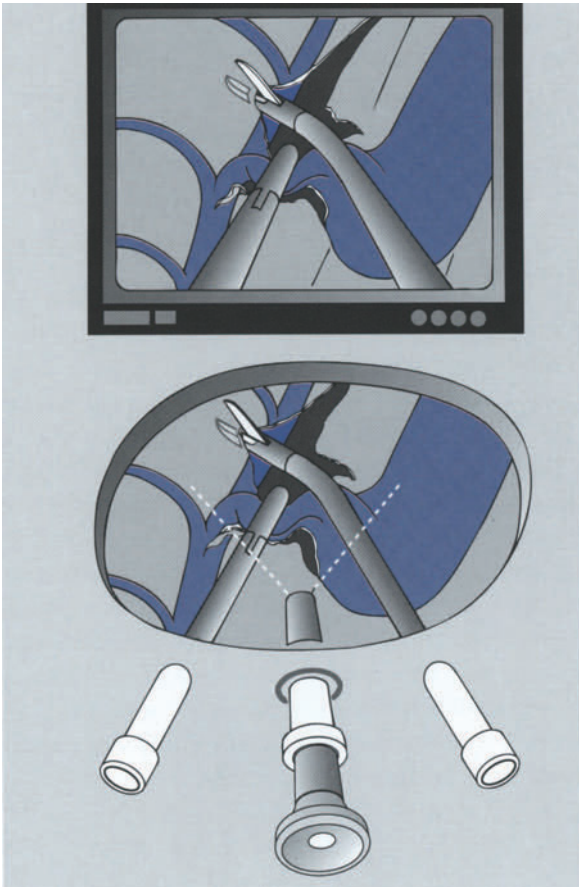
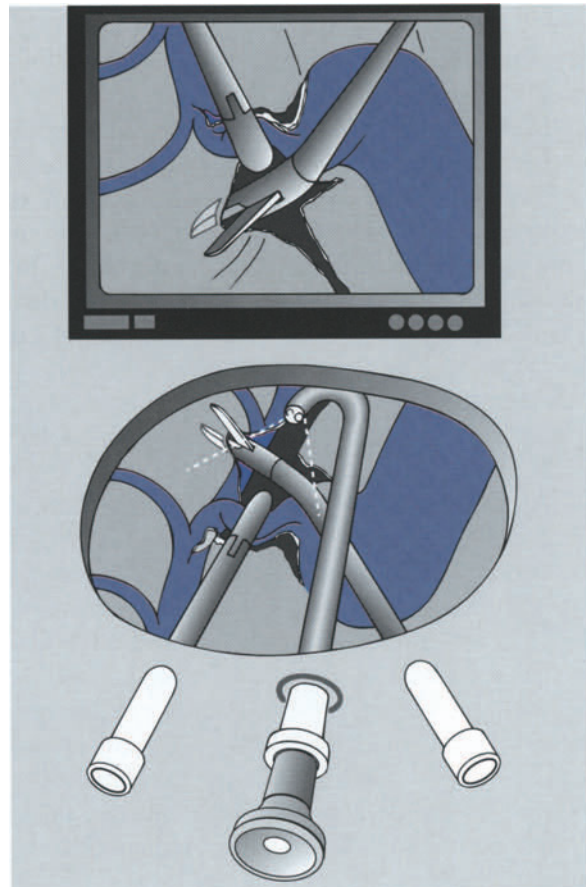
**a****b****c**

that these thin and delicate endoscopes are easily damaged, which, considering their price, is a major disadvantage for general use in endoscopic exploration of the bile duct. However, direct optic imaging of the biliary tract is desired and of considerable benefit for lithotripsy of common bile duct stones.

The use of a semi-flexible introduction sleeve through which the scope should be inserted through the cannula into the abdominal cavity is one way of preventing breakage.

### Semi-flexible Endoscopes

To construct a semi-flexible endoscope the conventional flexible endoscope was shortened and modified by a rigid intersection (e.g. Olympus Optical; Fig. 1.9a). Such a construction permits additional degrees of freedom of the viewing direction. However, the image quality of fibreoptics and the illumination do not fulfil all the endoscopic surgical requirements because they are inferior to rigid telescopes. The use of these flexibles scopes requires experience and care to prevent mishaps during surgical manoeuvres (Fig. 1.9b, c). Baxter has introduced a semi-flexible scope which is operated via a joy stick placed at the hand-piece. The movements of the front section are controlled by servomotors; however, orientation problems similar to those of fully flexible endoscopes occur during its utilization.

An adjustable viewing angle of the front lens of a rigid endoscope, for example, from  $0^\circ$  to  $90^\circ$ , is of considerable advantage, making change of the optic during complicated procedures unnecessary.

Although the optic quality of the rigid rod lens system is superior to that of fibrescopes, it restricts a viewing angle adjustment. Such a construction would require miniaturized moveable prism systems with adjustable optic segments as employed in Wittmoser's segmental optic [41]. Precise sealing would be required for cleaning, but autoclaving seems impossible.

An optical system which allows three-dimensional viewing with auto iris, auto focus, zoom and auto convergence combined with optimal resolution and colour reproduction is almost like the human eye. Such a system is required to provide the image quality that permits the highest possible

safety during an operation. With CCD chip technology [6] combined with micromechanics and microelectronics in a microsystem [15] it may be possible to create such a sophisticated optical system.

### Light Sources

There is no new technology of light generation and transmissions; however, existing systems have been refined. The new halogen metal vapour arc lamps emit light of daylight quality at a colour temperature of 5700 K. The life-time of these advanced bulbs can now be measured and they are simple to replace. The light sources still have some disadvantages: light cables can only be interchanged with special connectors, and the iris control is usually not interchangeable between cameras and light sources of different manufacturers. Automatic lamp changing and standardized interfaces of iris control and light cable connection are required.

### Intraluminal Illumination

Procedures such as cardiomyotomy benefit from intraluminal illumination with the gastroscope. The EndoLumina (BioEnterics, Carpinteria, CA, USA) includes a soft and transparent silicon elastomere bougie connected with a glass fibreoptic bundle that is designed to be attached to a light source. The light is transmitted through the surface of the bougie and thus transilluminates thin organic tissue such as the oesophagus wall. Different shapes and diameters are available. The device is autoclavable, but may not be soaked since the elastomere absorbs the disinfectant and subsequently leaks out, causing tissue damage.



a

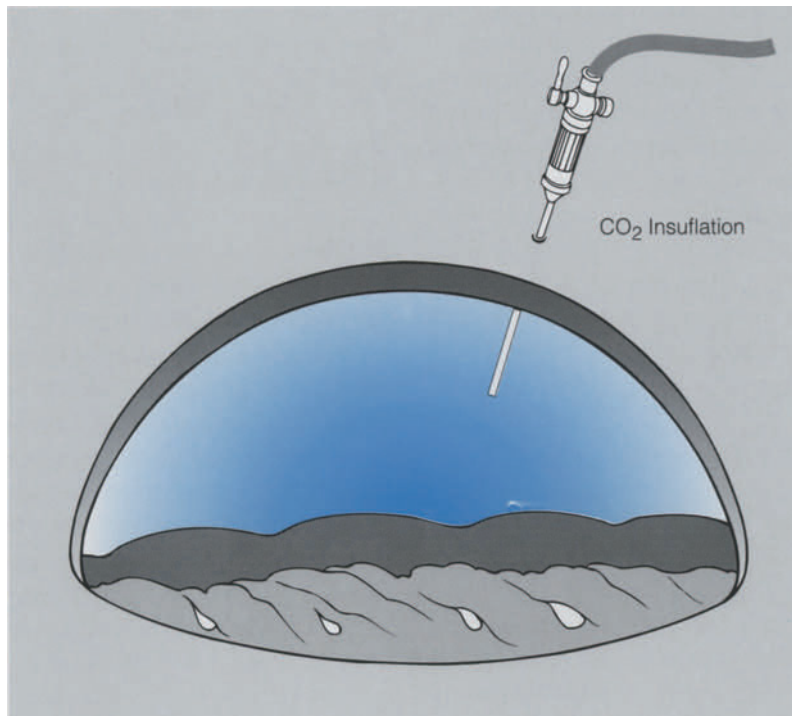

b

**Fig. 1.10 a, b.** Mechanical (a) versus gas pressure (b) distension of the abdominal wall. With mechanical lift there is insufficient exposure due to the non-uniform “tent-like” distraction of the abdominal wall, whereas gas insufflation

provides an adequately exposed operative field. However, gasless laparoscopy entails advantages for high-risk patients and in cases of trauma

## Exposure of the Operative Field

### New Technology of Mechanical Distension and Gasless Laparoscopy

Mechanical distension of the operative field is as old as surgery itself. Since introduced by Mouret in laparoscopic surgery, various devices such as hooks, barbs and fans have been used to distend the abdominal wall. Aside from simplicity, mechanical distension has certain advantages: gas insufflation can be avoided, it is reliable and instrument design is less restricted. Thus, a round cross-section of the instrument shaft is no longer essential.

From the clinical viewpoint the elderly or the trauma patient may benefit if extensive gas insufflation is avoided because there is less effect on ventilation and the risk of CO<sub>2</sub> embolism and emphysema are decreased. In addition, due to the intra-abdominal pressure the phrenic nerve may be irritated and cause shoulder pain. Particularly in the event of substantial bleeding mechanical distension permits immediate introduction of instruments without altering the haemodynamic condition of the patient. The disadvantages of mechanical lift include insufficient exposure, due to the non-uniform “tent-like” distraction of the abdominal wall (Fig. 1.10), and trauma to the peritoneum which may lead to adhesion formation. Some patients complain of postoperative pain in the area where the hook was introduced.

### Devices for Gasless Laparoscopy

The simplest method of mechanical lift is to apply sutures to the skin or insert a thick thread through the abdominal wall. The Dundee technique of suspending the abdominal wall by using a drain with an inserted rod (Fig. 1.11 a, b) is of considerable help during procedures such as fundoplication, vagotomy, etc. The soft plastic tube reduces traumatization of the peritoneum and postoperative pain in the suspended area. However, since this technique does not contain built-in safety features such as automatic release or spring gauge it has to be used with care.

Semm's suspension device is a simple rod with a hinge at the distal end. The tip can be deflected and a T-shaped barb results (WISAP, Sauerlach, Germany). A French suspender (Societe 3X, Caluire & Cuire, Paris, France) designed according to Mouret consists of a specially curved stainless steel rod which can be screwed through a small incision and then used to lift the abdominal wall (Fig. 1.11 c). However, damage to the peritoneum may be caused by both instruments. A fancier and more expensive device, the LaparoLift, is available from Origin (Menlo Park, CA, USA, Fig. 1.12). The principle is the same; a hook-shaped element (LaparoFan) is inserted through an incision and the abdominal wall is lifted. In our view the blades of the hook should be redesigned in order to improve their “atraumatic” design. This lift system is not sterilizable as it is large but it can be covered with a sterile polyethylene tube. Although, the LaparoLift is the only system with which overdistension might be avoided because of an integrated spring gauge, this is not achieved automatically. The limit for safe distension varies considerably from patient to patient and is influenced by several factors.

### Hydraulic Distension

Operations such as extraperitoneal hernia repair and urological procedures such as nephrectomy or removal of para-aortic lymph nodes require precise exposure of dedicated anatomical regions. An effective, but simple and cost-saving method is described by Rassweiler (Vol. 3). The finger of a conventional surgical glove is mounted at the tip of a laparoscope with instrumentation channel. Subsequent to blunt insertion and tunnelling, the finger is filled with a predetermined volume of saline solution (500–1000 ml). After initial filling, the balloon becomes transparent due to distension and thus the space created by blunt dissection of the anatomical layers can be visualized. Subsequent to aspiration of the balloon via standard suction and removal the scope can be positioned and the extraperitoneal operative field insufflated at 5–8 mmHg. Similarly functioning disposable balloons are available from Origin, General Surgical Innovations (Portola Valley, CA, USA) and others.



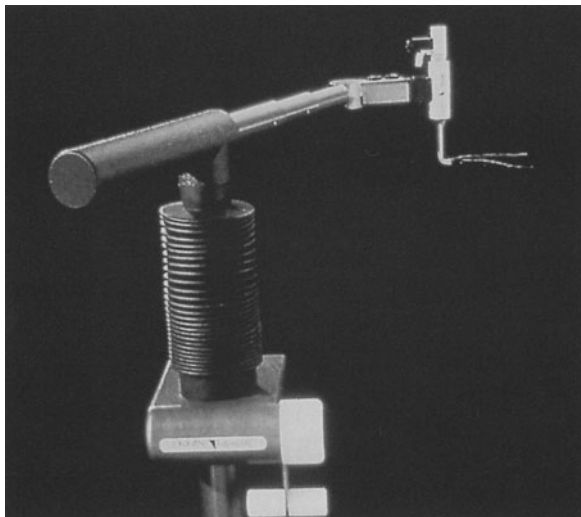
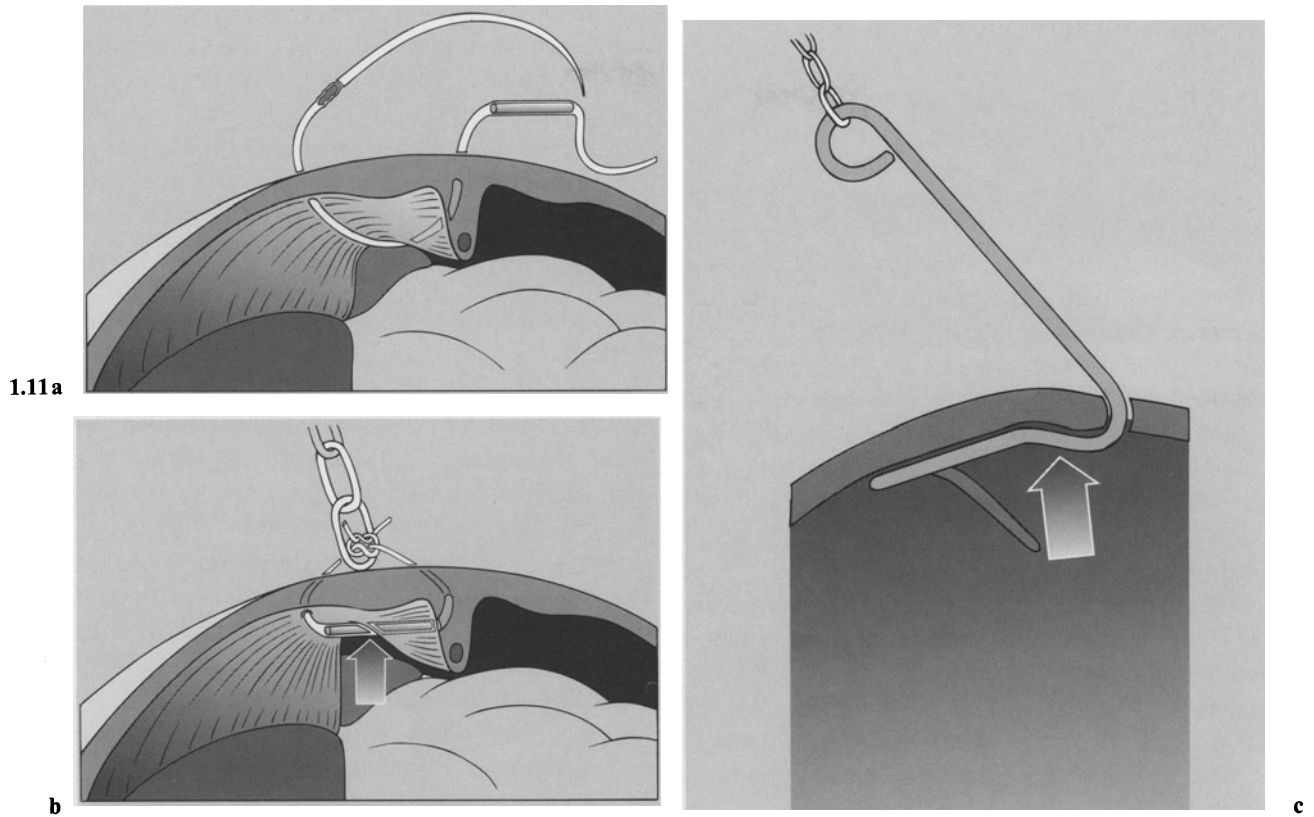

▲  
**Fig. 1.11 a–c.** Suspending the abdominal wall using a drain with an inserted rod (Dundee technique). **a** The first step includes the insertion of a drain trocar mounted with a silicon tube. **b** The stainless steel rod is then placed between the insertions and the tube is fixed to a gallow. **c** The suspender according to Mouret (Societe 3X; Caluire&Cuire, Paris, France) consists of a specially curved stainless steel rod which can be screwed into the abdominal cavity through a small incision

▲  
**Fig. 1.12.** The Laparo Lift device by Origin is electrically driven

## Gas Insufflation<sup>1</sup>

Several new types of gas insufflators have been introduced. Some important changes are electronic pressure and flow control, maximum gas flow of up to 20 l/min, electronic flow measurement, gas heating and filters.

### Pressure Control

Basically, an insufflator reduces the gas pressure of a CO<sub>2</sub> cylinder to low pressure needed in the human body. This pressure reduction is governed by the following parameters: intra-abdominal pressure, the insufflation (driving) pressure, the insufflation flow, and the gas temperature.

Intra-abdominal pressure is the most important parameter to control. Due to the blood pressure of about 10 mmHG in the vena cava, the intra-abdominal CO<sub>2</sub> pressure should not exceed 15 mmHG. Therefore, an insufflator should have a barrier against inadvertent CO<sub>2</sub> pressure preset for over 15 mmHG and a pressure relief system (Fig. 1.13).

Exact pressure control is of importance during suction and especially during argon beam spray coagulation. The use of argon beam coagulators, in particular, can cause major elevation of the intra-abdominal pressure. Furthermore, conventional irrigation and aspiration devices with piston pumps and imprecise adjustment also cause significant fluctuation of the intra-abdominal pressure.

Roller pumps, by contrast, are precisely adjustable to determined volumes (Fig. 1.14). For instance, if an argon beam spray coagulation device is used it insufflates approximately 4 l/min. The roller pump suction can then be adjusted to equilibrate pressure, provided a sucker is introduced. By contrast to the conventional suction device which aspirates ca. 2.4 l liquid per minute and sucks ca. 20 l air, a roller pump aspirates approximately the same amount of liquid and air (2.9 l/3.1 l).

The integration of a roller pump and aspirator would be more reliable and useful. This could automatically stop the gas input as well as aspirating the required amount of gas necessary to maintain the intra-abdominal pressure within defined limits. Such a system has recently been developed in Tübingen, the Operating System OREST I (Dornier Medizintechnik, Germering, Germany).

### Flow

The gas flow is created by pressure difference: the higher the pressure difference, the higher the flow. But the flow depends also on the flow resistors along the flow path (e.g. tubes, needle, trocar, etc.). During an operation of 1 h the consumption of CO<sub>2</sub> is about 60 l, resulting in an average flow of 1 l/min. The maximum flow of 20 l indicated by the manufacturers not only reduces the life-time of the gas bottle, but also represents potential danger for the patient due to the risk of overpressurization. However, as the maximum flow depends both on the driving pressure and the diameter and length of the supplying tubes, the maximum flow of the device is never achieved at the output site of the cannulae. Our examinations indicate a real flow of up to 6–9 l/min. A flow higher than 9 l/min seems unnecessary and carries considerable risks.

To prevent insufflation in the event of incorrect insertion of the Verres needle, e.g. intra-arterially, the driving pressure should not exceed more than 50 mmHg, which consequently reduces the maximum flow. In order to achieve both safe and stable pneumoperitoneum, an adequate pressure and flow control is necessary (which can be described as soft approach pressure control, SAPC). In addition, the output site (cannula) requires optimization and standardization. Most of the current insufflators work intermittently to obtain intra-abdominal pressure by means of pressure equalization. With a powerful controlling algorithm the average flow of such a device reaches 90% of a comparatively continuously working device. The advantage of the intermittently working device is the elegant pressure measurement without additional tubes. From the point of view of safety, the high-flow gas insufflation itself may cause severe complications, due to the lack of a safety valve, which would automati-

<sup>1</sup> In co-operation with S. Sawatzki, WOM, Berlin.

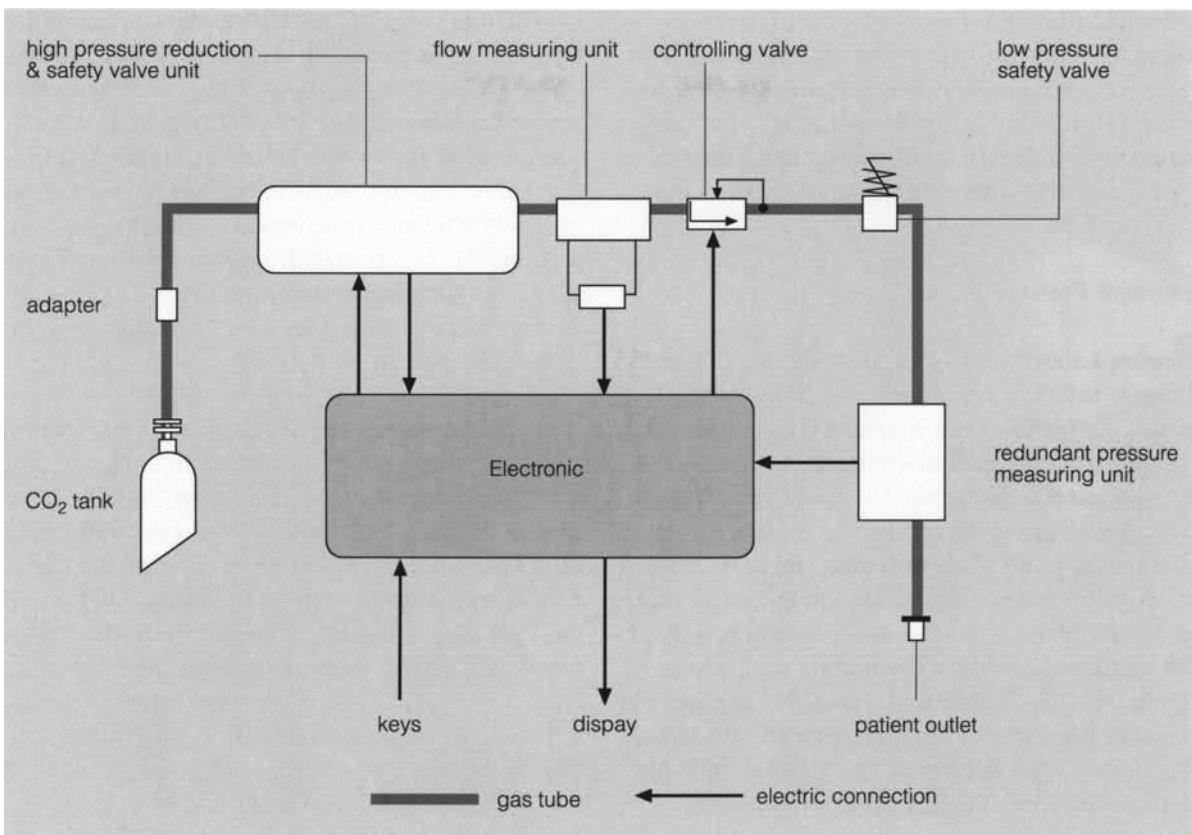

▲ **Fig. 1.13.** A modern insufflator with safety valves and electronic control of all functions

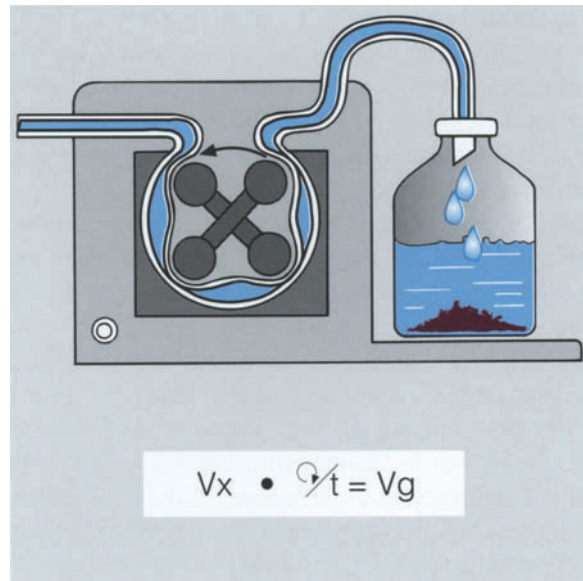

**Fig. 1.14.** The roller pump suction allows adjustment to determined volumes of either gas and liquid. Depending on the rotation speed of the roller, certain volumes are squeezed through the tube. Thus, excessive aspiration of gas is abolished

cally reduce the intra-abdominal pressure in the event of dangerous rise of the abdominal pressure. In this respect the conventional acoustic high pressure alarm is not sufficient. Although, the risk of overpressurization is minor, an insufflator equipped with such safety features should be preferred.

#### External Pressure Relief

Beacon Laboratories, Inc. (Broomfield, CO, USA) have a safety valve device, the Pressure Guard, which lets off gas when a preset pressure is reached. The device is simple but effective. An open plastic bag is placed at one of the IV stands of the patient. A scale indicating the pressure in mmHg is printed on the bag. Once filled with saline up to the desired relieving pressure level, e.g. 13 mmHg, and connected to one of the cannulae, every increase of the intra-abdominal pressure over the set level is relieved. The excess gas bubbles out into the atmosphere. The bubbling stops when the cavity pressure reaches the set level. However, the relief of overpressurization depends on gas flow from the insufflator and cannula type used.

#### Temperature Control

Expanding CO<sub>2</sub> gas cools down strongly, which is described by the Joule-Thomson effect. With the Joule-Thomson coefficient the gas temperature decrease of about 45 °C caused by a pressure reduction of 60 bar can be calculated. Regarding the low thermal capacity of CO<sub>2</sub> gas, the heating of a flow of 9 l/min to room temperature only requires a small quantity of thermal energy. The heat is created by the electronic components of the insufflator. At the output site of the insufflation tube CO<sub>2</sub> gas has reached room temperature. The only cooling effect to the patient is caused by CO<sub>2</sub> with room temperature. Although Semm advocates heating of insufflation gas, since the shoulder pain seems to be greatly reduced [42], the thermal capacity of CO<sub>2</sub> is not sufficient to decrease the body temperature significantly. A core temperature drop of 0.3 °C is caused by 40–50 l insufflated gas at room temperature [43]. Only in case of high flow

(ca. 9 l/min) does the intra-abdominal temperature drop 0.7 °C below intra-oesophageal temperature, but the body appears to be able to increase intra-abdominal temperature by 2 °C/min [44]. A comparison of nonheated gas and heated gas insufflation (Flow Therme, WISAP) has not revealed a significant difference in temperature drop in the two groups [45]. For extended laparoscopic operations with extensive insufflation rates the use of humidified and heated CO<sub>2</sub> may help to reduce thermal loss of the patient [46].

In comparison, the heating of 100 l CO<sub>2</sub> from room temperature to 37 °C extracts as much thermal heat from the patient as 200 ml irrigation liquid being warmed up by the patient by 3 °C. Due to its higher thermal capacity, the irrigation liquid can cause significantly more cooling of the abdomen than the insufflated CO<sub>2</sub>. Instead of heating the CO<sub>2</sub> gas, adequate temperature of the irrigation liquid seems more important.

#### Gas Reservoir

None of the insufflators currently available contains an additional gas reservoir. It is often noticed that it is necessary to change the gas bottle when the abdomen collapses. Aside from the hazardous risk, changing the gas cylinder causes a delay. The solution is quite simple: a main reservoir and a reserve cylinder. An acoustic or optic signal would indicate that the pressure in the main cylinder is decreasing and the reserve cylinder would then automatically be switched on. A manometer placed at the back of the insufflator should constantly show the actual reserve pressure. This additional reservoir would eliminate the inconvenience and danger of sudden decompression of the pneumoperitoneum during the operation.

The right choice of purchasing an insufflation device should be based on a thorough understanding of the clinical significance of several tests and evaluations [47] as well as the individual requirements of endoscopic operations. Besides technical specifications the insufflator should be easy to use, operate fully automatically, display intra-abdominal pressure and flow values clearly, and have a pressure relief system.

## Exposure Maintenance

During the operation the front lens is often stained by condensation and blood. Several useful antifog solutions are available for maintaining a clear view. To clean a stained optic and external instruments the laparoscopic scope warmer (Applied Laparoscopy; Laguna Hills, CA, USA) is useful. This sterilizable thermos bottle contains 500 ml of irrigation fluid which is kept hot for 3–4 h (Fig. 1.15). A more expensive telescope warmer, an electrically heated device is manufactured by Wolf; however, it cannot be sterilized and care has to be taken to cover it sufficiently with sterile polyethylene film.

## Optic Irrigation

Only few telescopes have integrated irrigation channels for maintaining the operative view. These are the TEM stereoscope and the Mediastinoscope (both by Wolf). The hydrolaparoscope (Circon AC-MI, Stamford, CT, USA) has recently been intro-



**Fig. 1.15.** The scope warmer (Applied Laparoscopy) is a sterilizable thermos bottle which keeps 500 ml irrigation fluid hot for 3–4 h

duced which permits both rinsing of the lens and irrigation of the operative field (Fig. 1.16a). Optic irrigation is imperative in delicate dissections, because accidental bleeding from a large vessel can quickly obscure the view. Bleeding was the most common cause for conversion from endoscopic procedure to open surgery in a multicentre study in major European centres [48].

## Combination of Insufflation, Irrigation and Suction

Since irrigation fluid drops at the front lens can impair the view until they dry, the Tübingen system combines suction, insufflation and irrigation to maintain a clear lens (Fig. 1.16b). The gas is introduced via a channel of an outer sleeve which fits to conventional 10-mm telescopes. The gas stream of the CO<sub>2</sub> is led over the objective lens and, hence, condensation is avoided (Fig. 1.16b<sub>4</sub>). In addition the front lens can be irrigated by means of a separate rinsing channel (Fig. 1.16b<sub>2</sub>). The front lens is immediately dried due to the constant gas output. This exposure maintenance system has been tested experimentally and clinically and is manufactured by Wiest (Munich, Germany).

## Energy Systems

### High-Frequency Devices and Instruments<sup>1</sup>

The quality of cutting and coagulation and the prevention of undesired side effects are of central importance during high-frequency (HF) surgery. Major prerequisites are the instruments and suitable generators as well as application techniques and their adequate execution. Once the surgeon is acquainted with the specific characteristics of HF surgery it becomes a versatile and safe technique for operative endoscopy.

<sup>1</sup> In co-operation with G. Farin, Erbe Elektromedizin, Tübingen, Germany.

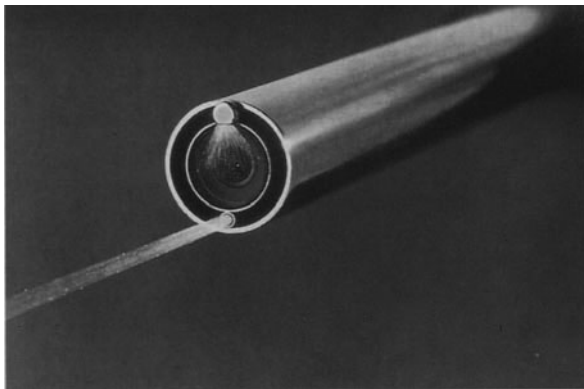

a

**Fig. 1.16. a** The hydrolaparoscope (Circon, ACMI) permits rinsing of the optic front lens as well as irrigation of the operative field. **b** The Tübingen system (Wiest) combines suction, insufflation and irrigation to maintain a clear view. The CO<sub>2</sub> is led over the front lens, thus drying drops of condensation. Smoke is aspirated due to the constant flow of gas

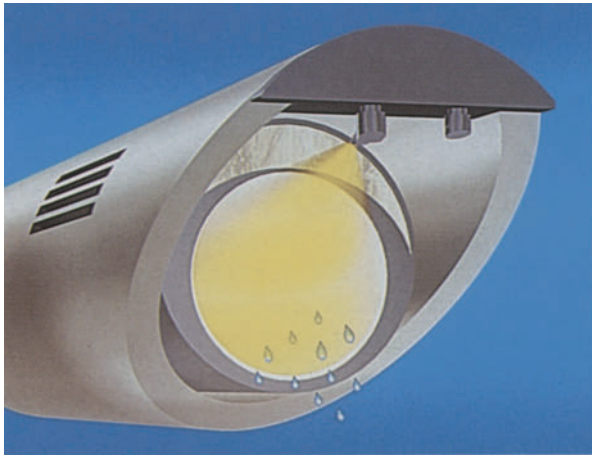
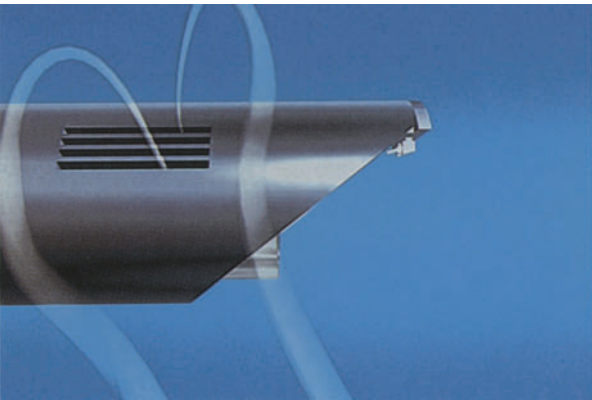
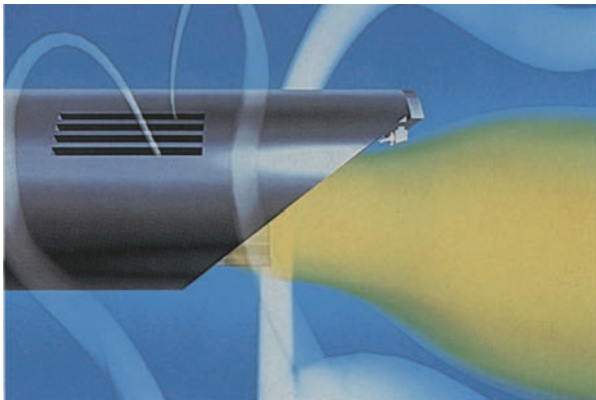
b<sub>1</sub>b<sub>2</sub>b<sub>3</sub>b<sub>4</sub>

### Quality of the Cutting

The quality of the cutting is determined by the type and extent of the thermal damage to the cutting margins. The tissue along the cutting margins should suffer as little thermal damage as possible so as to promote postoperative wound healing. Particularly, the delicate dissection of vascularized structures requires adequate differentiation of tis-

sue layers. For histopathological examination of the specimen, precise cutting is mandatory. However, the cutting margins should be coagulated sufficiently to ensure efficient haemostasis while cutting. Carbonization of the cutting margins should be avoided under all circumstances, and tissue vaporization should be kept to a minimum because the vapour and smoke obscure the endoscopic view.

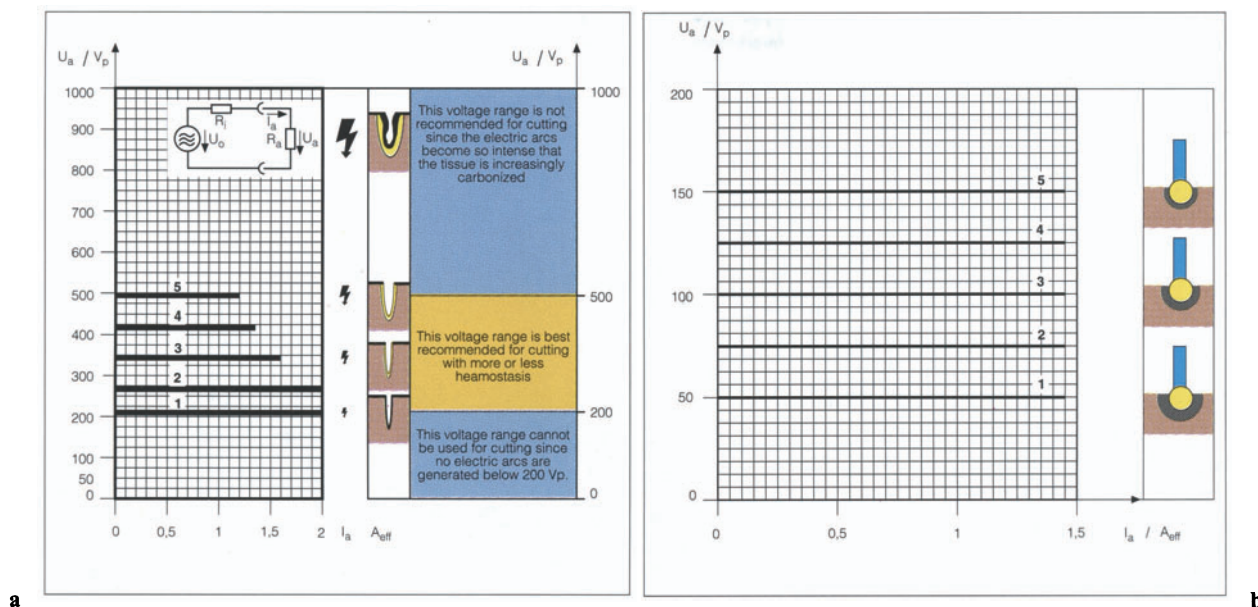

### Reproducible Cutting

The quality of the cutting depends on the intensity of the electric arc between the cutting electrode and the tissue, and the electric arc on the level of the electric voltage, the shape of the cutting electrode and the cutting procedure. The amplitude of the HF voltage between the cutting electrode and the tissue must reach at least 200 V, since the electric arc cannot be ignited at lower voltages. The higher the HF voltage, the greater the intensity of the microelectric arc and thus of the thermal damage to the cutting margins (Fig. 1.17 a). "Low-coagulation" cutting can be achieved with low, unmodulated HF voltages, thin-cutting electrodes and swift incision. "High-coagulation" cutting is achieved with high HF voltages, thick-cutting electrodes and slow movement during cutting. However, the amplitude of the HF voltage should not exceed 500 V, since the electric arc between the cutting electrode and the tissue becomes so intensive that carbonization and vaporization develop.

Since the amplitude of the HF voltage and the intensity of the electric arc between the cutting electrode and the tissue determine the quality of the cutting effect, HF surgery devices with automatic voltage or arc control should be used in order to ensure a reproducible and constant quality of cutting. This also precludes the undesired side effects such as carbonization and vaporization.

**Fig. 1.17. a** The relationship between high-frequency (HF) voltage, intensity of the microelectric arc and thermal damage to the cutting margins. HF devices with automatically regulated HF output provide reproducible quality of the cutting effect. **b** The relationship between HF voltage and intensity of the coagulation effect. HF devices with automatically regulated HF output voltage in the "soft coagulation" mode ensure absence of electric arcs and maintain a soft and moist coagulum

### Quality of the Coagulation

An important criterion for the quality of the coagulation is, again, the type and extent of the thermal damage to the tissue. As regards the extent of the coagulation zone, the reproducibility of the intended effects and the prevention of the unintended effects play an important role. It should always be ensured that only as much tissue as is needed for therapeutic purposes is coagulated. Desiccation (dehydration) of the coagulated tissue leads to shrinkage, which thereby supports haemostasis. However, desiccation can also lead to adhesion of the coagulated tissue to the electrode, thus incurring the risk of tearing it off from the surrounding tissue and inducing bleeding [49]. Carbonization represents a considerable risk for postoperative adhesion and should therefore be avoided [50].

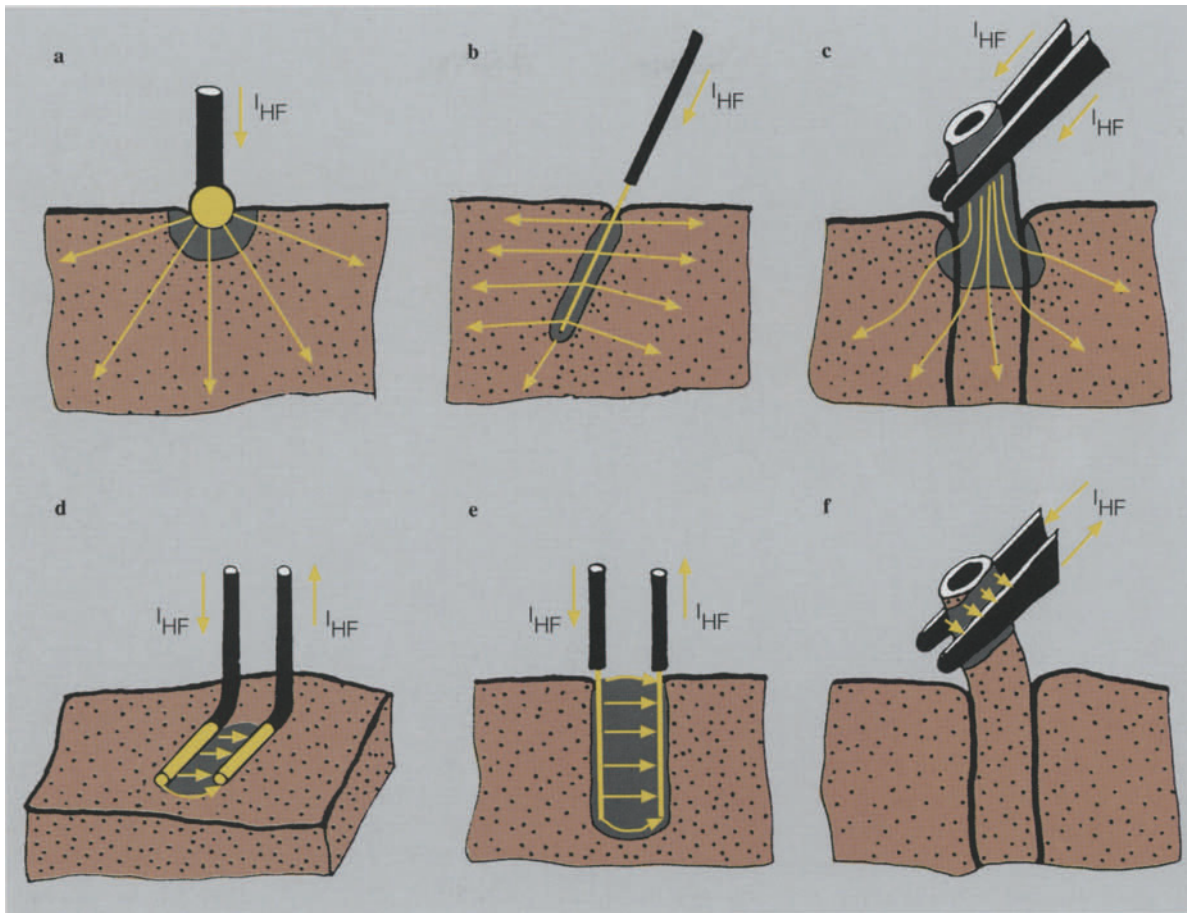

### Reproducible Coagulation

Coagulation depends particularly on the level of the electric voltage between the coagulation electrode and the tissue. Pure coagulation with adequate desiccation, minimal vapour formation and without carbonization can be achieved with HF voltages of amplitude ranging between 20 V and a maximum of 190 V. If the amplitude of the HF voltage exceeds 200 V, then electric arcs are formed which produce carbonization and smoke. As the coagulum remains soft and moist in the absence of electric arcs, this coagulation mode is termed “soft coagulation” (Fig. 1.17b).

In monopolar coagulation, the spatial development of the coagulation zone is proportional to the effective surface of the contact and inversely proportional to the square of the electric voltage between the coagulation electrode and the tissue (Fig. 1.18). In bipolar coagulation, the spatial de-

**Fig. 1.18 a–f.** Comparison of the spatial development of the coagulation zone of monopolar (a–c) and bipolar (d–f) high-frequency (HF) current. a, d contact coagulation; b, e puncture coagulation; c, f spread coagulation

velopment of the coagulation zone is largely limited to the tissue between the poles of the bipolar coagulation instrument. Because of the strong influence of the voltage on the spatial development of the monopolar coagulation zone, HF surgery device with automatic voltage control should be used.

Excessive desiccation and adhesion between tissue and electrode can largely be avoided by means of the automatic switch-off of the coagulation process when the vapour phase has been reached in the coagulum. This is related to the change of the tissue’s electrical features and lowered water content.



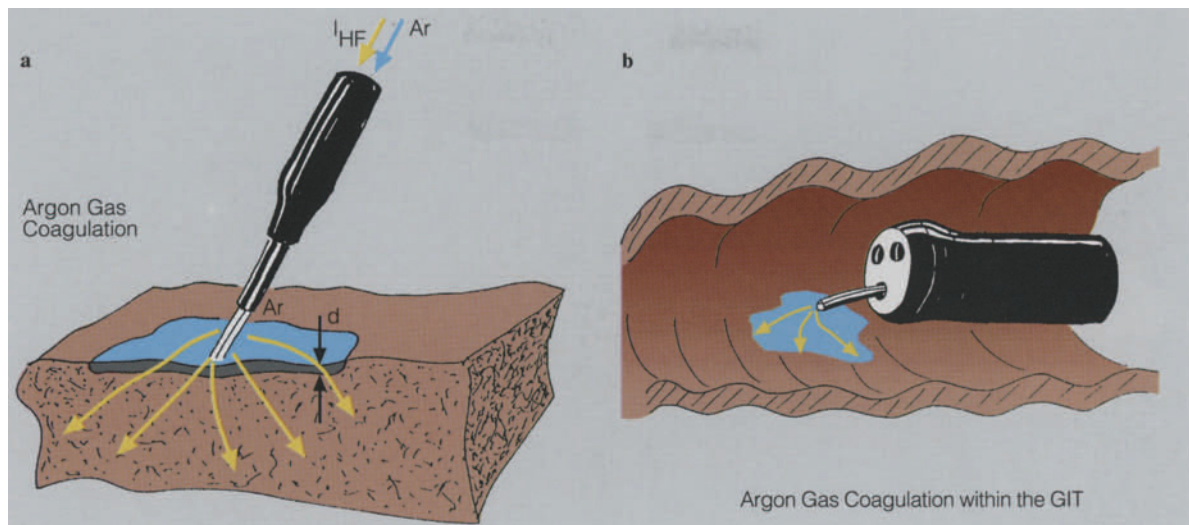

Since sometimes a relatively large area must be coagulated with a small monopolar electrode, the electric voltage between the electrode and the tissue must exceed 200 V. Electric arcs have to be generated which sufficiently penetrate electrically insulating layers of dried out tissue. This coagulation mode is termed “forced coagulation”. When applying “forced coagulation” in the presence of air, desiccation, carbonization, vaporization and the adhesion effect must be expected. However, when applying forced coagulation or other HF modes in combination with irrigation fluids such as water, these unintended side effects become minor or entirely nonexistent [51].

Voltages with amplitudes above 2000 V generate electric arcs of such length that contact of the active electrode with tissue becomes unnecessary. Although a surface coagulation can simply be gained by moving the electrode over the tissue at a distance, a reproducible coagulation effect is not possible. In the presence of oxygen this “spray coagulation” leads to considerable carbonization, vaporization and adhesion, which limits its application during endoscopic operations.

### Inert Gas Coagulation

Argon gas coagulation is the preferred method for contact-free coagulation of tissue surfaces. Here the HF current is applied to the tissue by means of

**Fig. 1.19 a, b.** The different application techniques of inert gas coagulation. **a** The argon gas is ionized due to the high-frequency (*HF*) electrical field and thus forming the electric arc which leads to a relatively constant coagulation depth of the tissue without significant carbonization. **b** Flexible application of argon gas coagulation within the gastrointestinal tract

an electrically ionized argon gas jet [52]. Argon is suitable for this because it is naturally relatively ionized and it has a high electric conductivity. The chemically inert argon prevents the carbonization and vaporization of the coagulum. Correct application technique leads to a relatively constant coagulation depth and well-controlled desiccation of the tissue surface, which permits adequate haemostasis (Fig. 1.19 a, b). Once a HF generator with a sufficiently controlled constant HF voltage is used, the depth of the coagulation zone is reproducible.

Argon gas coagulation is now a proven method for haemostasis in the gastrointestinal tract [53] as well as being useful for pulmonary [54] and splenic surgery [55]. In addition to a HF surgery device, argon gas coagulation requires a controlled argon source and an argon gas coagulation probe suitable to the specific application.

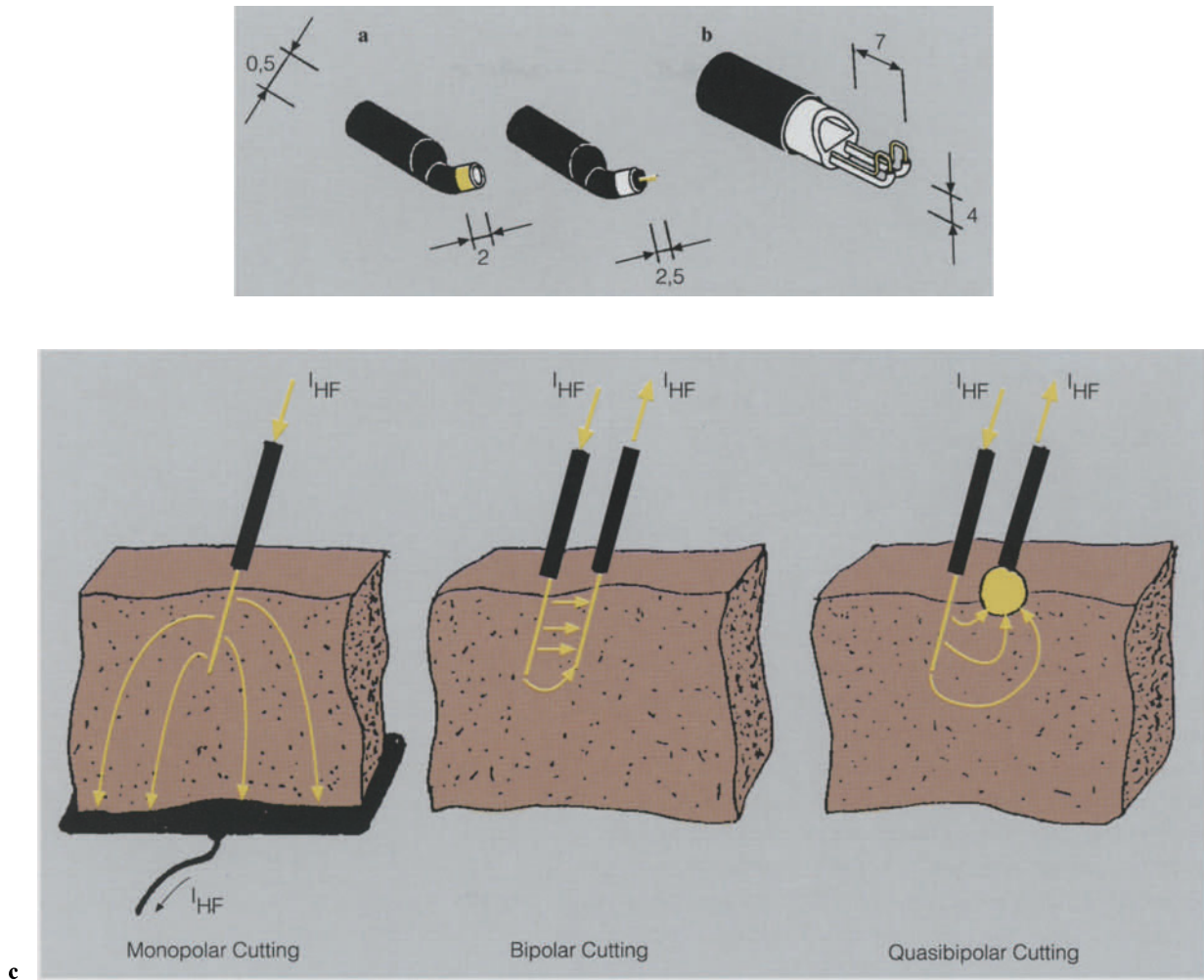

### Instrumentation for HF Surgery

Today, a broad spectrum of monofunctional, bifunctional and multifunctional HF surgery instruments is available for cutting and coagulation, and also in combination with other functions (Fig. 1.20).

#### Cutting Instruments

The simplest cutting instrument regarding design and application is the monopolar cutting electrode in needle form. In endoscopy surgery the thin-needle electrode can function as a scalpel for precise dissection and cutting. The advantage of thin-needle electrodes is that the HF current required for cutting is so low that there is only minimal thermal

**Fig. 1.20 a–c.** Examples of bifunctional cutting/coagulation instruments. **a** The needle is used for cutting, the distal ring for coagulation. **b** The two thin wires are used for bipolar cutting, the two thicker wires for bipolar coagulation. This instrument is additionally equipped with an irrigation channel. **c** The three different cutting techniques; monopolar (*left*); bipolar (*middle*); quasibipolar (*right*). *HF*, high frequency

damage to lateral tissue structures. A HF surgery device with automatic maximum voltage or arc control carries advantages for the use of HF needles. If the minimum voltage of 200 V necessary for cutting is not achieved, thin-needle electrodes may easily bend or even break and stick in the tissue. At voltages with amplitudes higher than 500 V a thin needle can quickly glow away. In order to abolish this risk, bipolar and quasi-bipolar cutting elec-

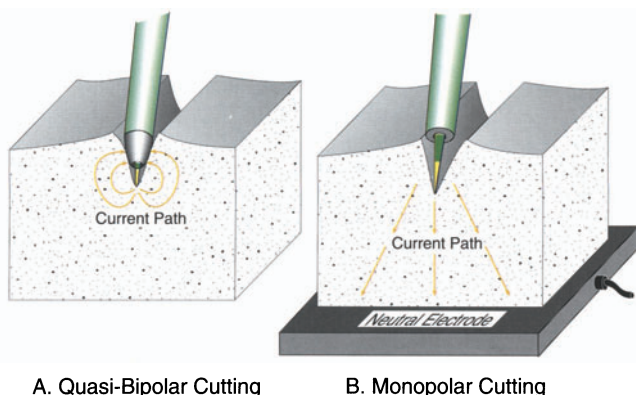

A. Quasi-Bipolar Cutting

B. Monopolar Cutting

**Fig. 1.21.** Monopolar (*right*) and quasibipolar (*left*) needle electrodes with adjustable needle length are available for preparation cuts with critical incision depth. (From: Endoscopic Surgery Allied Technologies 1 (1993) 103, Thieme Verlag, Stuttgart)

trodes have been developed. The “quasi-bipolar” needle electrodes combine both the above-mentioned advantages in application of a thin-needle electrode and the safety advantages of a bipolar electrode. Figure 1.20c gives a schematic representation of the three different cutting techniques. Monopolar and quasi-bipolar needle electrodes with adjustable needle length are available for preparation cuts with critical incision depth (Fig. 1.21).

### Coagulation Instruments

As opposed to conventional surgery and flexible endoscopy, instruments designed specifically for coagulation are rarely used in endoscopic surgery. In order to save the time needed for changing instruments, suction tubes or forceps are often used as monopolar or bipolar coagulation instruments. Hooks primarily designed for blunt manipulation of preparation are also used as cutting and coagulation instruments in arthroscopy and laparoscopy. The utilization of these instruments represents a compromise between optimal function and time saving. Figure 1.18 shows various coagulation techniques which can be carried out with both monofunctional, bifunctional and multifunctional instruments.

### Bifunctional Cutting/Coagulation Instruments

Bifunctional cutting/coagulation instruments incorporate principally two surgical techniques. An instrument primarily designed for cutting is used for coagulation, such as practised in transurethral resection (TUR) with the resection snare, or the instrument is equipped with separate cutting and coagulation electrodes. Coagulation with an instrument designed primarily for cutting entails the risk of unintended cutting. This can be ensured if the “soft coagulation” mode described above is applied. If “soft coagulation” does not provide sufficient haemostasis due to too small an effective contact area, “forced coagulation” can be applied. However, due care must be taken, as “forced coagulation” carries the risk of a cutting effect due to the electric arc. In order to reduce this risk, the diameter of the cutting instruments is increased as is necessary for a low-coagulation cutting quality. Bifunctional cutting/coagulation instruments are equipped with a cutting and a coagulation electrode (Fig. 1.20, 1.21). Figure 1.22 represents a sectional drawing of a multifunctional cutting-coagulation instrument. The needle electrode is advanced automatically by means of a pneumatic actuator which is activated prior to the HF current.

### Multifunctional Instruments for HF surgery

Cutting and coagulation have been combined with other functions, such as suction, irrigation, grasping, mechanical dissection, ultrasound dissection etc. to produce multifunctional instruments. As multifunctional instruments are not only connected with a HF surgery device, but also with suction and irrigation equipment, complex systems are formed that must be co-ordinated with regard to ergonomics and safety (Fig. 1.22).

### HF Surgery Device

Today, HF surgery devices are available for operative endoscopy that meet the requirements for reproducibility of cutting and coagulation effects and in the prevention of undesired side effects. By means of automatic monitoring, regulation and

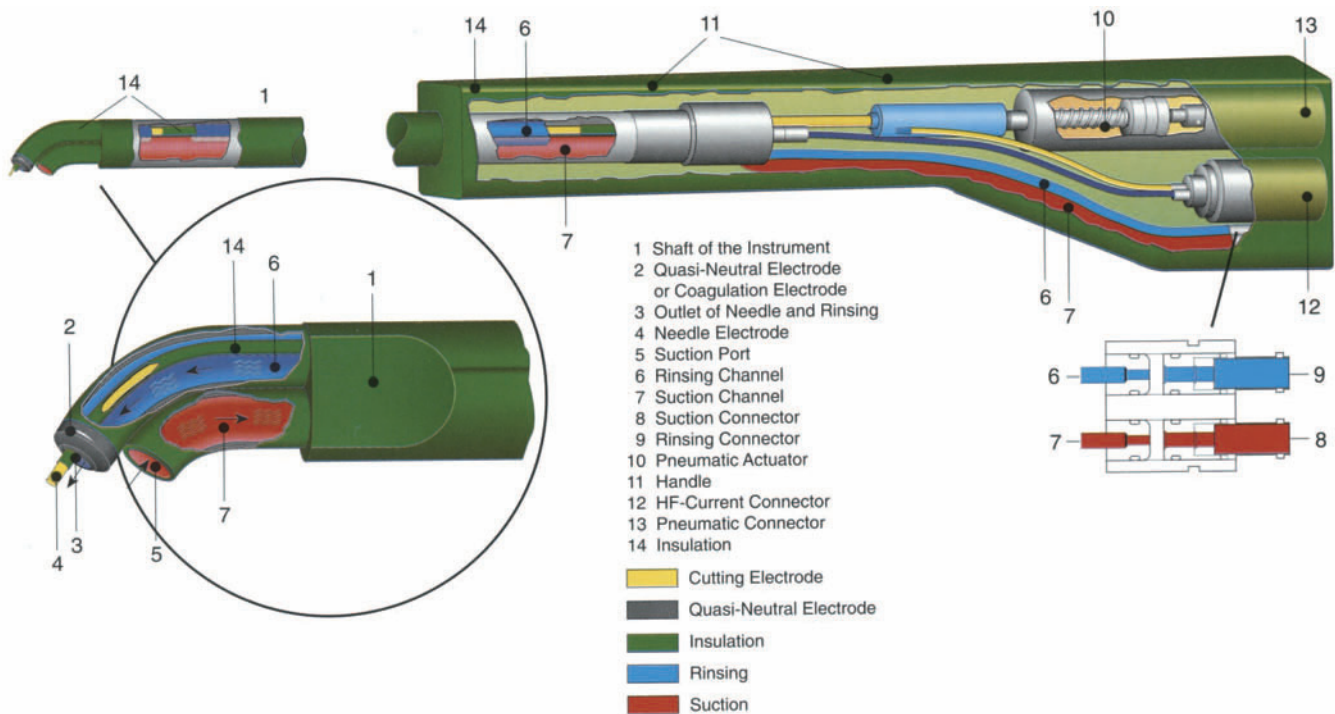

**Fig. 1.22.** Sectional drawing of a multifunctional instrument with pneumatic actuator. (Multifunctional instrument from Erbe, Tübingen, Germany, designed for endorectal surgery). When the cutting mode is activated, the bipolar cutting needle is pneumatically advanced. (From: *Endoscopic Surgery Allied Technologies 1* (1993) 98, Thieme Verlag, Stuttgart)

control of the electrical parameters the quality of the cutting and/or coagulation effects are ensured. As multifunctional instruments require complex control and monitoring functions to operate, these instruments and devices should be equipped with interfaces through which they communicate with each other. In order to assure sustained availability of the systems, the relevant devices should be equipped with automatic error detection and report functions. In operative endoscopy, a HF surgery device or a corresponding surgical instrument can no longer be viewed independently of each other, but must be treated jointly as components of a system [56].

## Therapeutic Ultrasound

The use of vibrations in ultrasound frequency is not limited to diagnostic imaging purposes. Several reports of liver surgery with ultrasonic dissection have been positive [57, 58]. A recent introduction has been the use of vibrations in the harmonic range, leading to a cutting and coagulating instrument for endoscopic surgery, the “harmonic scalpel” (Ultracision, Smithfield, RI, USA).

## Ultrasonic Dissection

With ultrasonic dissection damage to vessels ducts and nerves can be avoided whilst soft tissue such as fat or glandular parenchyma are separated or cleaved. This is achieved through a cavitation effect which occurs at the tip of the vibrating rod of the device (25 000/s). The ultrasonic high energy converts water to steam. Thus, the efficacy depends on the water content of the tissue and the cells which are in contact with the dissection tip. Fat and parenchymatous cells contain more water than connective tissue, thus the cavitation effect causes

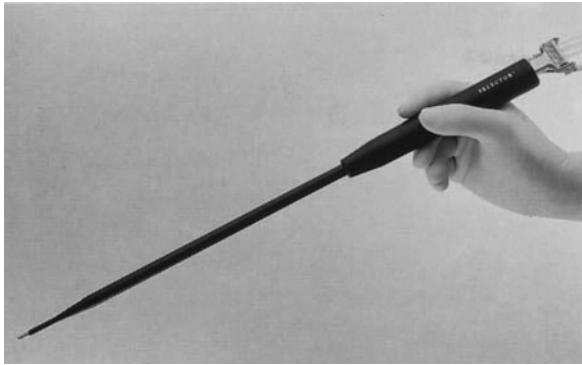

**Fig. 1.23.** The ultrasonic dissector by Surgical Technology Group (Andover, Hampshire, UK) carries significant advantages for dissection of parenchymatous organs. Similar devices are available from ValleyLab/Pfizer and Söring

fragmentation of parenchymatous cells and fat but structures containing significant amounts of collagen such as vessels and nerves are left intact. Figure 1.23 shows the ultrasonic dissector by Surgical Technology Group (Andover, UK). Similar devices are available from ValleyLab/Pfizer (Boulder, CO, USA) and Söring (Quickborn, Germany). Additional electrocoagulation functions are optionally available. The ultrasonic and HF current can be activated simultaneously. Their effects are additive and as the HF is conducted in electrolytic solutions, vessels, ducts and nerves are coagulated. The

HF should, therefore, be applied carefully and certainly reduces the safety margin of the ultrasonic probe. A combination of a HF hook with an ultrasonic dissection probe is available from Erbe.

### Ultrasound Cutting

If the frequency of the vibrating tip relative to the central rod is increased up to 55 000 Hz (harmonic range), the energy applied to the tissue which is in contact with the probe generates sufficient heat for coagulation. The thermal effect is dominant. If the tip is shaped like a scalpel, cutting and slightly coagulating effects are produced. The increased frequency, however, causes technical difficulties, including interference and resonance, especially when the vibrations are transmitted over a long distance (40 cm). The “harmonic scalpel” (Ultracision) is remarkable, because the knife is not really sharp and only cuts when the tip is vibrating in the harmonic range. The coagulating effect is, however, not deep and seems to be insufficient to prevent bleeding. Variant instruments are available with coagulation tips; spatulae and even a scissors have recently been introduced. All instruments have been clinically tested [59] and are available in 5-mm sizes (except the scissors). Figure 1.24 illustrates the thermal effect of ultrasound, HF and laser.

**Fig. 1.24.** Comparison of the thermal effect of ultrasonic (*left*), high-frequency (*middle*) and laser (*right*)

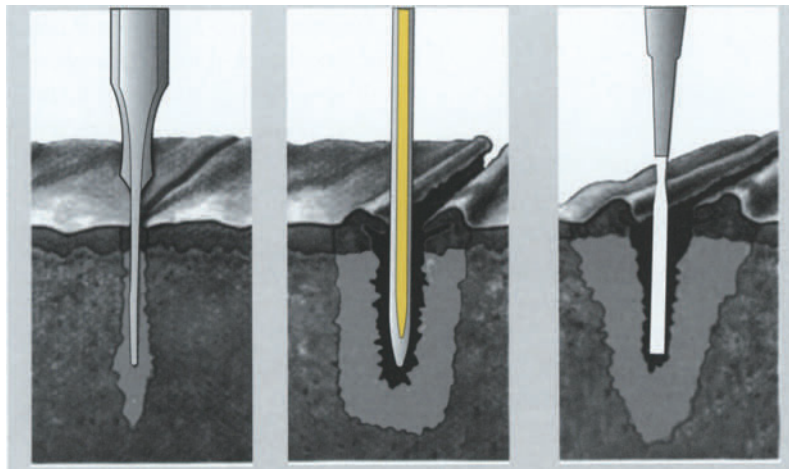

## Gallstone Lithotripsy

Gallstone fragmentation techniques vary from simple mechanical disintegration to ultrasound, piezoelectric and laser fragmentation [60, 61]. For endoscopic purposes all these techniques have both advantages and disadvantages.

In mechanical lithotripsy soft stones are grasped and crushed with a forceps or using the Dormia basket. More sophisticated lithotripsy can be performed using unique and very effective motor driven systems such as LaproLith and RothoLith (Endomedix). The RothoLith is flexible and was developed for percutaneous gallstone fragmentation, the LaproLith mainly for disintegration of gallstones prior to removal of the gallbladder. When switched on, the stones are completely fragmented within seconds and the residual liquid mixture can be aspirated easily. However, very large stones cannot be fragmented because they do not rise in the vortex caused by the rotating blade.

## Ultrasonic Lithotriptors

The ultrasonic desintegration of stones is based on the cavitation effect which was explained above. The shock impulses create shock waves which disintegrate the stone. The difficulties in transmitting the vibrations to the tip limit the length and the flexibility of ultrasound lithotripsy probes. The efficacy is low and depends on the composition of the stones, so that only the stones with high bilirubin and calcium content are fragmented efficiently by this technique.

## Electrohydraulic Lithotripsy

Shock waves can be created electrohydraulically by means of two exposed electrodes (wires) at the tip of the probe. An electrostatic charge generated by a piezoelectric element produces a spark at the tip which creates a shock wave. The disintegration effect is greater than that caused by ultrasound and 60%–80% of stones can be fragmented. However, direct tissue contact of the probe may damage soft tissue.

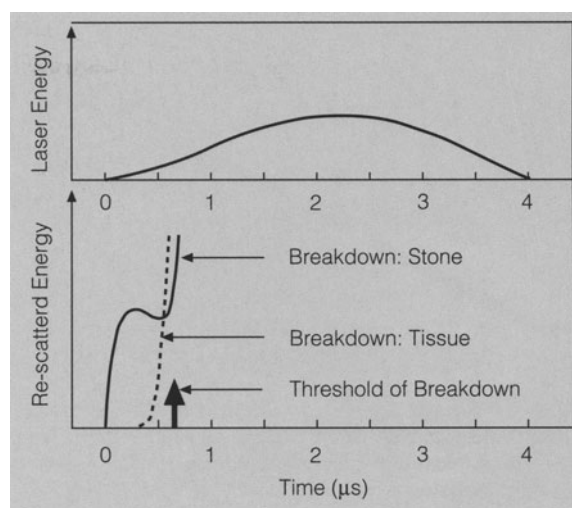

**Fig. 1.25.** The “Lithognost” laser (Telemit; Munich, Germany) produces a low, intensive laser light impulse prior to the main shot. The reflected light is analysed and the characteristic absorption of calculi is a precondition for activating the main pulse

## Laser Lithotripsy

Laser lithotriptors are very expensive but stones can be detected by means of light absorption. The Telemit laser “Lithognost” (Telemit, Munich, Germany) creates, when activated, a low, intensive laser light impulse which is absorbed, depending on the material illuminated (Fig. 1.25). The reflected amount of laser light is immediately, within nanoseconds, measured and if no specific light absorption characteristic of calculi is indicated, the main laser impulse is not activated. This principle is important because even under endoscopic view tissue damage caused by the laser impulses cannot totally be abolished. The fragmentation rate is adequate, although the disintegration rate of large stones is slow, taking up to 20 min.

## Instrument Holders

Instrument holders are not mandatory for routine operations. However, in emergency gallbladder surgery, for example during the night and if not enough assistance is available, an instrument holder can be very useful.

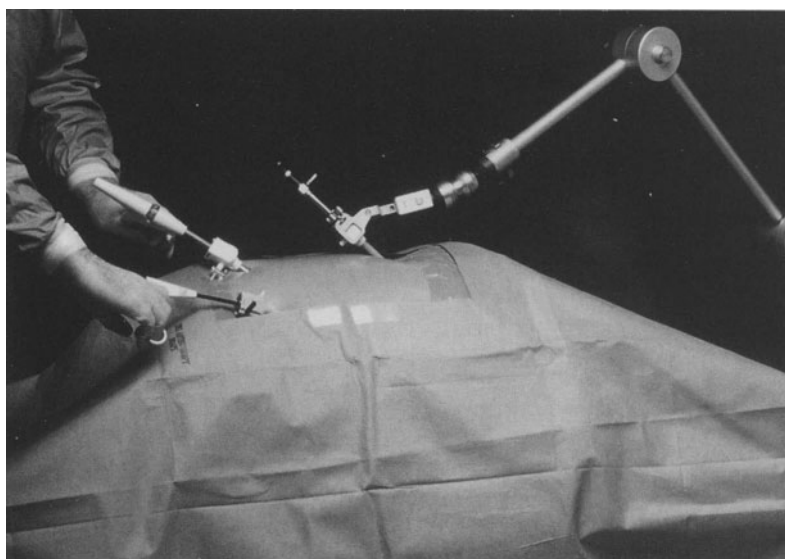

Complicated surgery, e.g. colonic resection, requires five or even more access channels. The surgeon who has to cope with several instruments making extensive movements is often hindered by the close proximity of his assistants. Hence, we have evaluated the feasibility of mechanically assisted operations. The one-man operation is, in fact, possible and with some experience easy to perform. However, its feasibility depends on the quality and features of the instrument holder. The Robotrac (Aesculap; Tuttlingen, Germany) has an inherent disadvantage: it collapses when both joints are unlocked. In addition the Robotrac is not autoclavable, but its holding force and position maintenance are excellent.

The autoclavable “first assistant” from Leonhard Medical (Huntington Valley, PA, USA) operates by vacuum locks which use conventional operating theatre suction and passive retraction so that it cannot collapse. Due to the vacuum principle, there is less holding force than with the Robotrac but the force is adequate for most applications [62–64]. The “little brother” has the same features (Fig. 1.26). The mechanical interfaces to the Leonhard arm enable adaptation of different instruments in addition to the telescope.

Having to control and adjust mechanical holders during a complex surgical procedure disrupts the continuity because frequent change of the position of the optic is required. Hence, the ideal holder

**Fig. 1.26.** The autoclavable “first assistant” from Leonhard Medical is operated by vacuum locks using conventional operating theatre suction

should have a voice-controlled locking function and manoeuvrability. However, such an intelligent holder is comparable to a manipulator and requires delicate technology. Computer Motion Inc. (Goleta, CA, USA) has developed the first robotic positioning system for endoscopes – the automated endoscopic system for optimal positioning, AESOP. The system comprises an arm with three segments interconnected with joints that are driven by servomotors. The arm needs protection with a sterile polyethylene tube. The movements can be programmed both by remote control and with a foot pedal. One of six programmable buttons simply has to be pressed at an important position and subsequent AESOP remembers operative sites by pressing the buttons correspondingly. However, as both patient position and anatomy vary, the programming has to be repeated, which is time consuming. The system can be activated via a foot pedal while the other instruments are operated simultaneously. However, as HF is controlled by a foot pedal, the foot control of the AESOP may lead to confusion.

From an educational point of view the assistant should not be replaced by holders or robot arms. However, as voice recognition and eye-tracking are

under development robotic instrument holders may enhance the efficacy of endoscopic surgical manipulations.

## Access Instruments

### Trocars and Cannulae

Several types of trocars and cannulae have been developed. The new features include valve systems, safety mechanisms, flexible trocars, new introduction principles and adapters which allow instruments of varying cross-sectional diameter to be employed without the need for reducer flops or tubes. The importance of safer penetration of the abdominal wall has led to several developments such as: the insertion of a needle scope into a Verres needle [65], complex access cannulae [66] and the principle of using an “optic scalpel” [67]. It seems likely that access and port problems will be resolved within the next few years. However, standardization of the trocars and cannulae remains an important consideration.

### Passive Dilatation

Passive dilatation of the access channel is achieved via a blunt trocar with cone-shaped tips. This system is used mostly in reusable cannulae (see Vol. 1, Chap. 2).

### Active Cutting

Penetration by means of sharp pyramidal trocars reduces the force required to traverse the abdominal wall. However, the sharp tip of the trocar may cause severe injuries [68] if the shield does not deploy quickly enough (Fig. 1.27 a, b). The principles of the safety shield, described in Vol. 1, Chap. 2, have been extended by new designs. A trocar from Dexide (Fort Worth, TX, USA) is a sharpened tube with a blind rod inside which moves forward when the abdominal wall is negotiated (Fig. 1.28 a). The trocar (developed by Origin) retracts within approximately 1 ms subsequent to the penetration of the abdominal wall (Fig. 1.28 b). This adds consider-

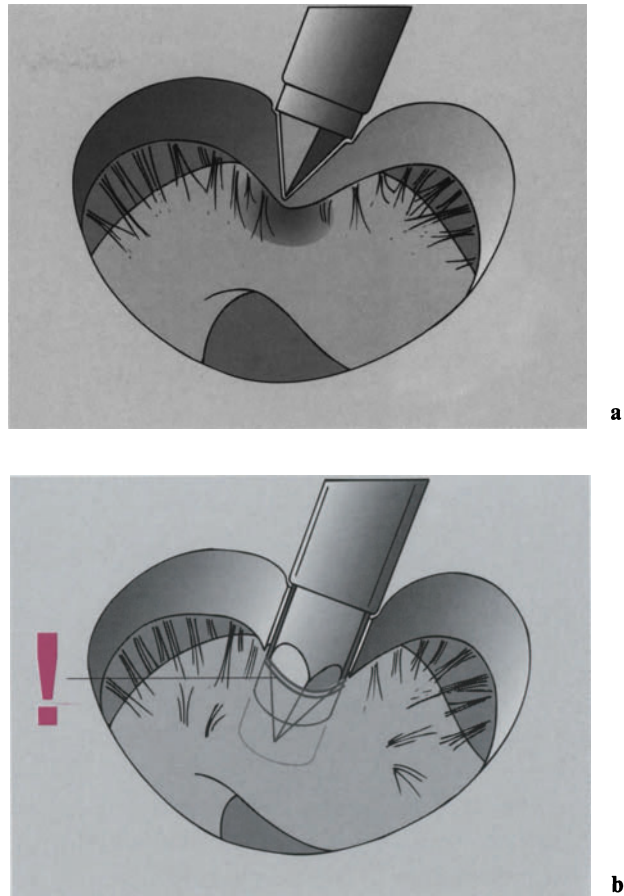

**Fig. 1.27 a, b.** Safety trocars may help to avoid severe damage of intra-abdominal organs. However, the sharp tip of the trocar may cause severe injuries if adhesions are present

able safety because the retraction can be hampered by adherent structures. Bühler (Tuttlingen, Germany) markets a reusable safety shield trocar.

Although all these trocars are considered “safe”, the bowel may be injured in the presence of adhesions. Hence, the use of sharp trocars demands experience and great care, even although recent studies [69, 70] indicate fewer bowel injuries.

The electrosurgical trocar Accucise is marketed by Applied Laparoscopy. The trocar consists of a plastic rod with a diathermy loop mounted on the tip (Fig. 1.29). The introduction force is approximately the same as with sharp trocars. Because the current is not automatically switched off when the abdominal cavity is reached, the internal organs may be injured, particularly in the presence of adhesions. These electrosurgical trocars are best intro-



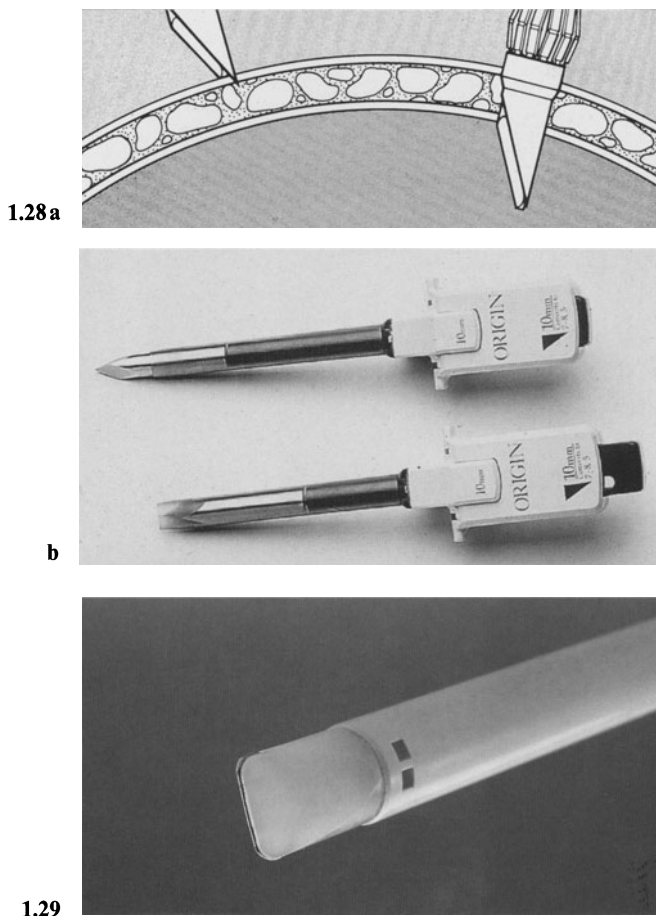

**Fig. 1.28.** a Dexide (Fort Worth, TX, USA) markets a trocar which employs a sharpened tube with a blind rod inside which moves forward when the abdominal wall is negotiated. b Disposable cannula with retracting trocar (Origin)

**Fig. 1.29.** The Accucise trocar (Applied Laparoscopy) incorporates a plastic rod with a diathermy loop mounted on the tip

duced under vision. Their advantage is reduced bleeding from the stab wound caused by the trocar.

### Controlled Active Cutting

The new “optic scalpel” (Olympus Winter&Ibe) consists of a special endoscope which allows simultaneous contact view with transillumination of tissue and a focus on objects at a distance [67]. The focus is adjusted via a separate ring at the ocular site. The 5-mm, 30° telescope is introduced into a stainless steel tube scalpel which has a sharpened distal end and fits in a trocar. This trocar allows a

dilatation up to 10 mm (Fig. 1.30a–e). The puncture is performed using the tube scalpel which can be moved via a hinge at the handgrip of the system.

Investigations on the abdominal wall of pigs in phantom and animal experiments have revealed a certain “colour code” that permits identification of the anatomical intersections (Table 1.1).

The puncture channel can be visualized by moving the endoscope to and fro and the layers distinguished by their “colour-coded” anatomical structure. However, both colour intensity contrast are low, thus the orientation requires considerable experience. The contact view is afforded by a special optic adapter for tissue transillumination, so that large vessels can be detected and spared. In addition to the colour code, the resistance of the anatomical structure is useful in identifying the layer reached while performing the insertion: fat and muscle allow easy passage, whereas the fascial intersections require active dissection. The reflection intensity of the peritoneum (white in an adhesive bowel loop or vascularized tissue; translucent in free intra-abdominal space) indicates the possibility to provide a “safe window” for entry into the cavity. The optic scalpel also seems useful for preperitoneal approaches because the surgeon can access the area of interest under visual control.

### Valves

#### Active Valves

Among the active valves are the manually controlled trumpet or flap valves. Flap valves are mainly used in disposable devices. In reusable trocars, cleaning and maintenance of flap valves is difficult

**Table 1.1.** “Colour code” of the anatomical structures of the abdominal wall

Anatomical structure	Colour
Fat	White reflection
Muscles	Light red
Fascia	Bright white reflection
Peritoneum	
Adherent internal structure	Opaque/bright reflection
Free abdominal cavity	Translucent/vascularized

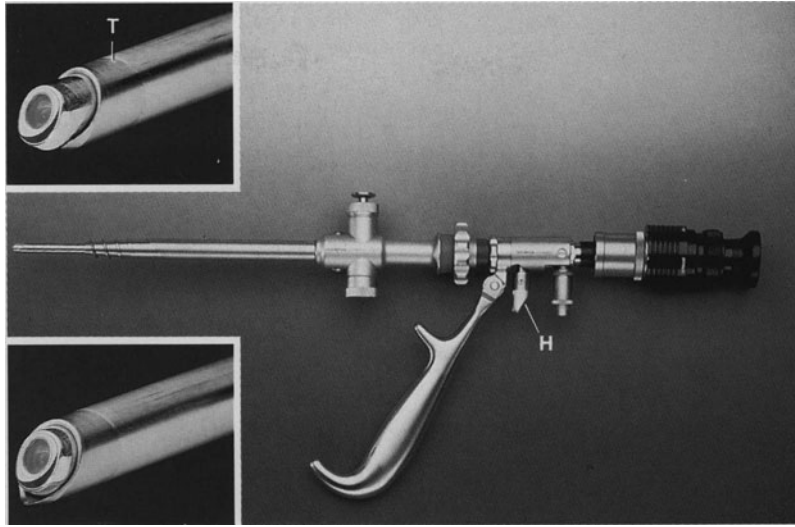

a

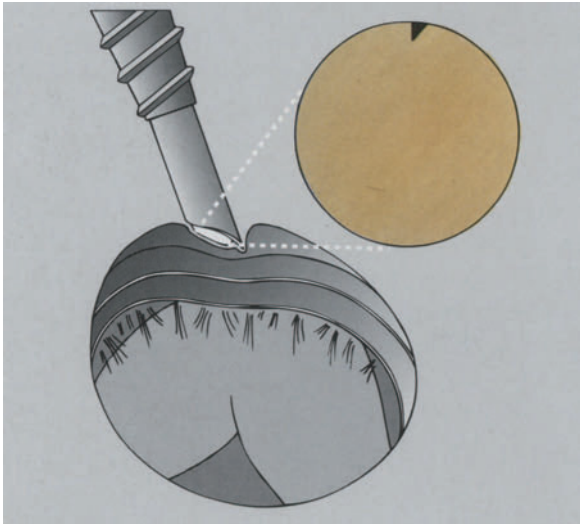

b

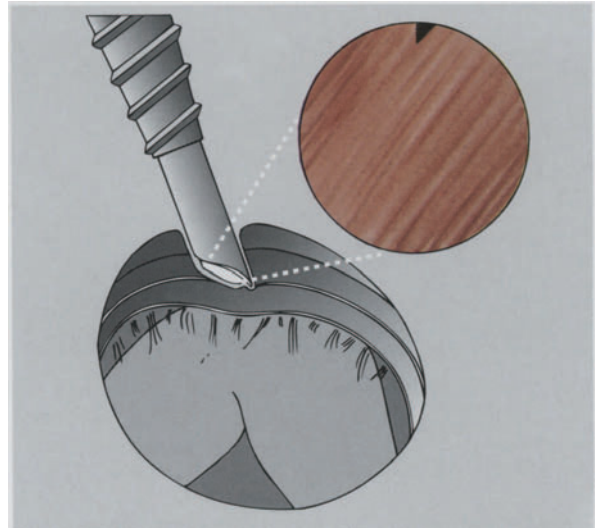

c

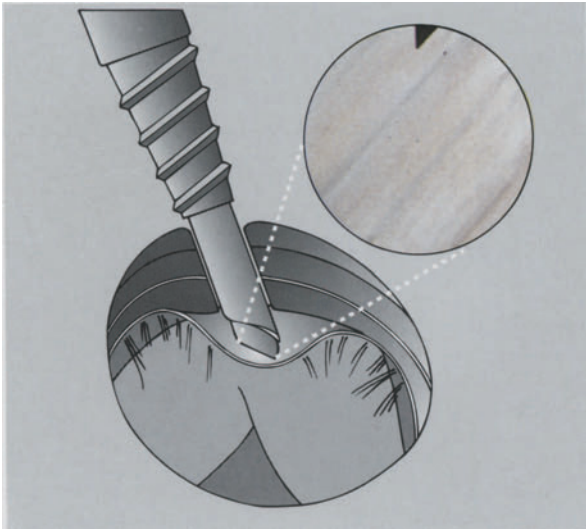

d

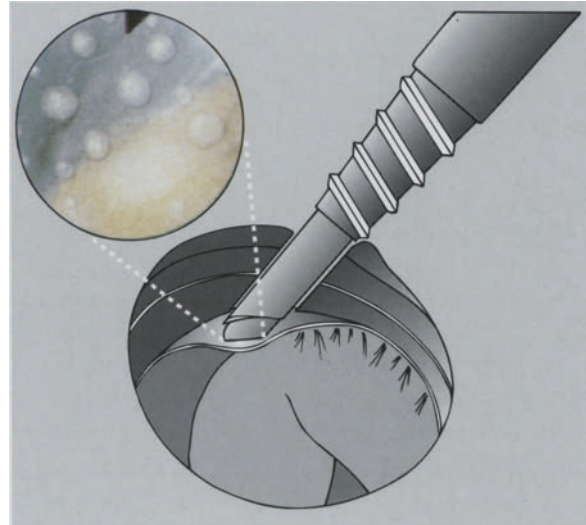

e

and time consuming. The small springs are the major weak point. They do not seal sufficiently when tissue fragments lodge between the flap and its seat.

The sealing quality of trumpet valves is excellent even under dirty conditions. However, the sharp-edged piston of the valve has to be kept fully open during insertion and withdrawal of instruments, otherwise the cannulae may be removed or the insulation of the instruments scratched (Fig. 1.31 a), and this may lead to a complete blocking of the cannula. A solution to this problem has been offered by Aesculap by means of the locking piston (Fig. 1.31 b). The piston can be withdrawn, secured and subsequently released by pressing the small button.

In general, trumpet valves can damage instruments and thus some experience and concentration is required when using them. The passive silicon valves are best; they do not require any controlling mechanism and seal adequately under most circumstances.

### Passive Valves

The silicon rubber seal made by Apple (London, UK) is simple and reliable (Fig. 1.32 a). The trocar sleeve is made of plastic which is temperature resistant. However, the company does not allow it to be reused because the autoclaving does not meet standards. The hot steam and EO may affect the internal structure of the material, which can weaken it considerably and leave toxic residues. The rubber sealing provides easy insertion of any instrument and sufficient friction to keep it in place. The cannulae is screw shaped, which protects it from being accidentally removed while withdrawing an instru-

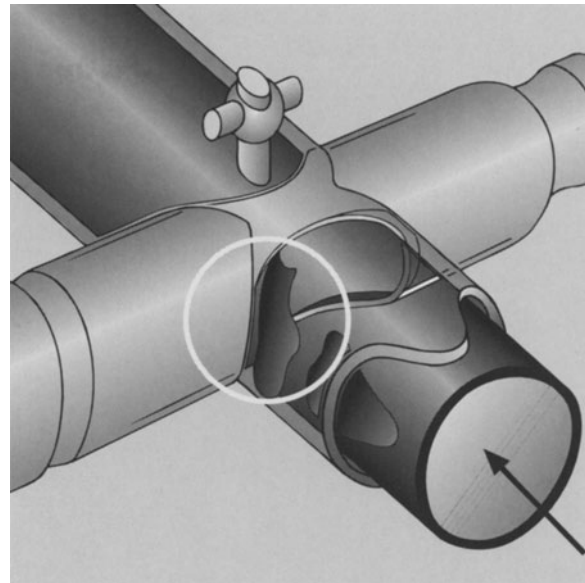

a



b

**Fig. 1.31.** a The piston of the trumpet valve has to be kept fully open during insertion and withdrawal of an instrument, otherwise the cannulae may be removed or the insulation of the instrument scratched and damaged. b Aesculap, uses a locking piston that permits free movements of the instruments. Simply pressing the button releases the piston

←  
**Fig. 1.30 a–e.** The “optical scalpel” (Olympus Winter&Ibe) permits an active, controlled, sharp penetration of the abdominal wall. The optic is inserted into a tubular scalpel (*T*) which can be operated from outside by a small hinge (*H*). Due to the colours of the different anatomical layers of the abdominal wall: fat, yellow (**b**); muscle, red (**c**); fascia, white; peritoneum, vascularized translucent or bright reflecting opaque, orientation is provided while penetrating the abdominal wall. The colour of the peritoneum indicates whether there is a free intra-abdominal cavity (**e** upper left) or whether there is an adhesion (**e** lower right)

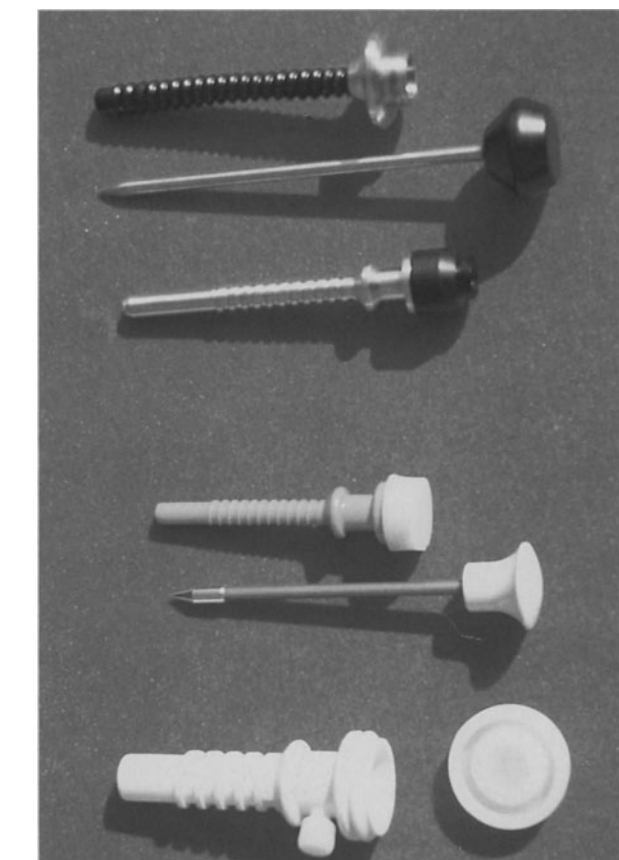

a

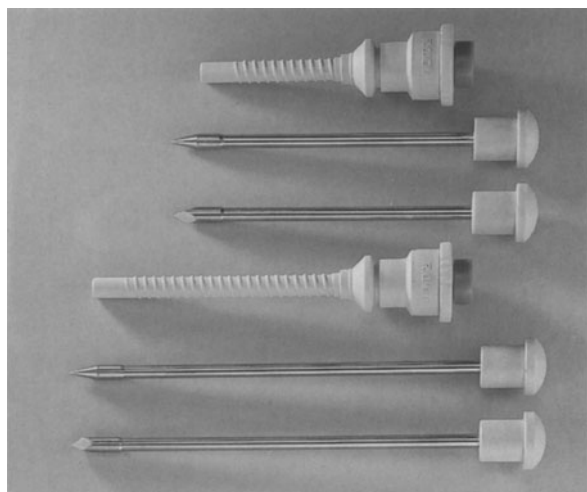

b

**Fig. 1.32 a, b.** Disposable trocars (Apple, London, UK; PCI, Liptingen; **a**) and Wolf (**b**) are equipped with simple silicon valves. The friction at the instrument is sufficient and only minimal gas leakage occurs during insertion or withdrawal of the instrument

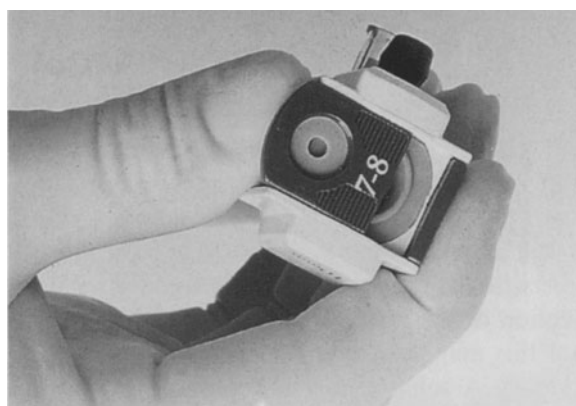

a

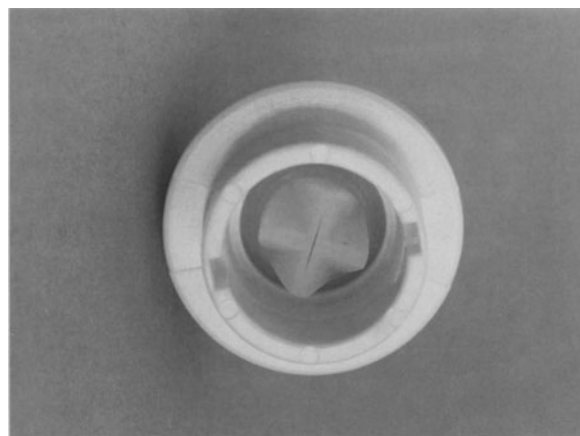

b

**Fig. 1.33. a** Origin markets cannulae with built-in converters that allow simple one-hand transposition. **b** A variable diameter seal (Applied Laparoscopy) permits the insertion of instruments from 4.5–10.5 mm in diameter without changing reducer caps

ment. Similar reusable cannulae are marketed by Wolf (Fig. 1.32b).

#### Diameter Seal

All cannulae incorporate a seal at the entrance of the valve. Apple use this entrance seal as a part of the valve itself. However, the 10-mm cannula can only take around 10-mm instruments with adequate seal leakage. If a 5-mm instrument is introduced and moved from side to side, there is loss of gas. Hence, the 5-mm instrument must be used with an adapter, either with a reducing tube or with additional seals. The latter is included in the Origin trocars as a set of seals and can be changed easily with one hand (Fig. 1.33 a).

The excellent variable diameter seal is made by Applied Laparoscopy (Fig. 1.33b). It seals adequately within a range from 4.5 to 11.5 mm and the instrument can be moved from side-to-side without leakage. However, the cannulae are disposable.

### Anchorable and Self-retaining Cannulae

The Hasson cannulae are anchored with sutures to keep them from sliding out of the abdominal wall [70]. This principle is quite useful and most of the available trocars allow the fixation of thread at the valve housing (Fig. 1.34a).

#### Screw

The screw shape of the trocar sleeve may allow easy and reliable fixation of the cannula in the abdominal or thoracic wall, provided that the screw flanks are adequately designed. The majority of cannulae screws have simple elevations similar to conventional screws [71]. The soft human tissue, however, requires relatively deep threadings with smoothed edges. In particular for dilatation from 5 to 10 mm such a design alleviates the screwing considerably.

#### Balloon

The balloon anchoring of cannulae is exemplified by the Marlow (Willoughby, OH, USA) and Origin devices (Fig. 1.34b). The major restriction is the minimal space for the balloon. However, the smooth surface may reduce trauma to the peritoneum. These cannulae are disposable as the balloon fixative precludes resterilization.

#### Mechanical Sheath Expansion

Mechanical spread cannulae have some advantages in terms of firm anchoring (Dexide). They are simple and reliable and their space requirement is low. In Fig. 1.34c various products are shown. Regrettably, this useful type of fixation is only available as a disposable cannula. Cleaning problems impede reuse.

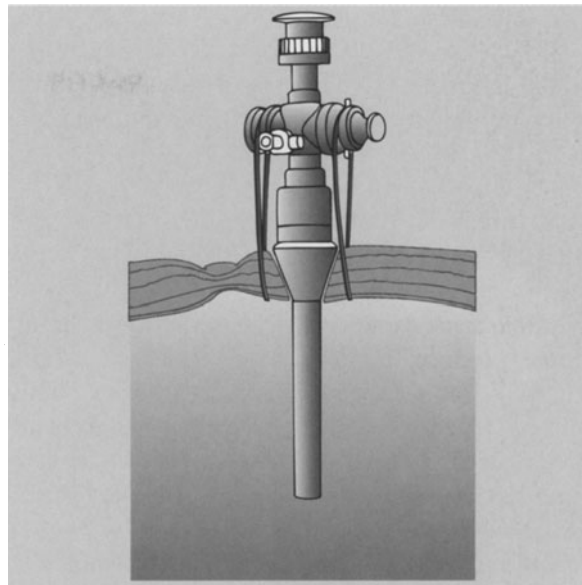

a



b

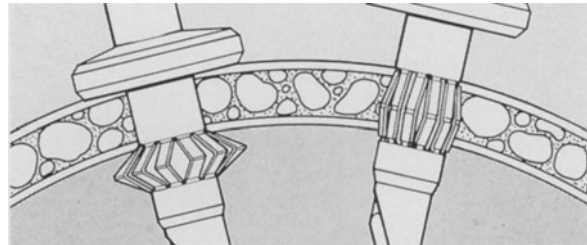

c

**Fig. 1.34.** **a** The Hasson cannulae are anchored with sutures to the abdominal wall, preventing gas leakage and accidental withdrawal of the cannula. **b** Marlow and Origin deploy balloons retaining the cannulae in place. **c** Mechanical sheath expansion keeps the Dexide cannulae from sliding out

## Flexible Trocar Cannulae

Basically, there are two types of flexible cannulae: elastic synthetic tubes or flexible metal tubes (Table 1.2) [72].

### Flexible Metal Cannulae

Flexible metal cannulae can be made from a spring. Storz produce this type of cannula based on a tightly coiled spring principle. This design is robust and allows easy insertion of the curved instruments (Fig. 1.35a). The instrument has to be inserted carefully and the jaws firmly closed, otherwise the instrument penetrates the coil. The coils are subsequently separated, while the curved instrument is introduced or negotiated. The immediate recoil ensures that there is only a momentary leakage of gas, which is not a particular problem once the cannula is fully introduced. Acceptable fixation is achieved after insertion of the curved instrument, because the opening slits clamp the tissue. To remove the cannula the trocar must be inserted to ensure exact alignment of the coils, otherwise they retract and may be damaged [73]. Silicon valves are going to be added to these reusable flexible cannulae.

### Synthetic Flexible Cannulae

Synthetic elastic tubes are also suitable for flexible cannulae. Shaping characteristics of the plastic are important in choosing appropriate material, e.g. for a reusable instrument the plastic needs a high temperature resistance of about 200°C. The most suitable material is polytetrafluoro-ethylene (PTFE; Teflon, Fig. 1.35b). However, its elasticity

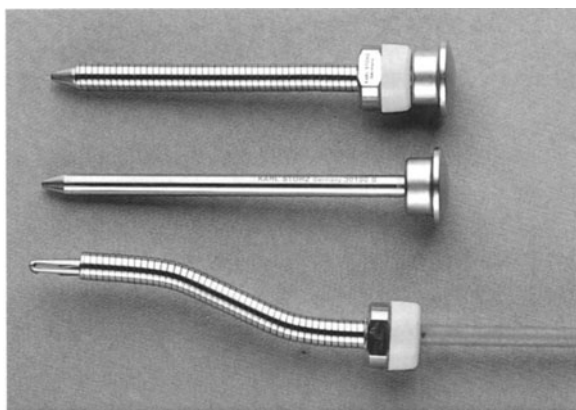

a

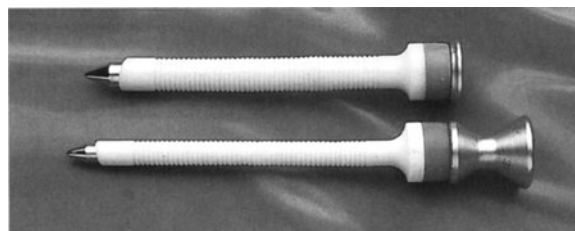

b

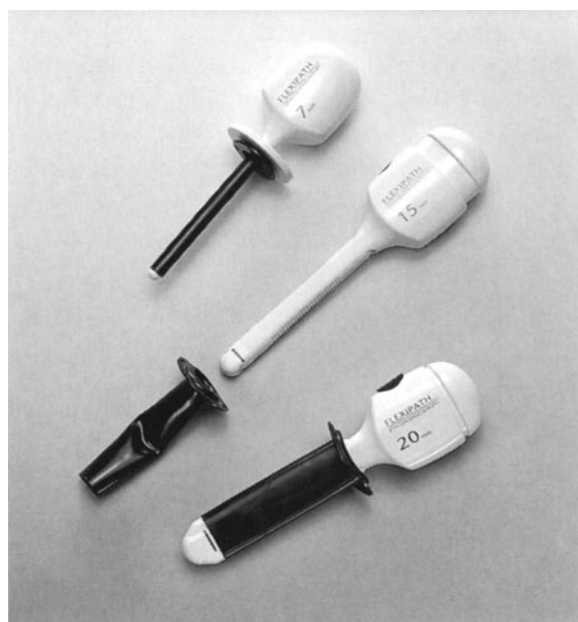

c

**Fig. 1.35.** a Storz produces flexible cannulae based on the tightly coiled spring principle. For removal of the cannula the trocar has to be fully inserted to ensure alignment of the coils. b Flexible cannulae made from Teflon tubes (Wolf). c Soft plastic cannulae with special introducer (Ethicon, Cincinnati, OH, USA)

**Table 1.2.** Basic requirements for flexible cannulae

Cleanability
Biocompatibility
No kinking while the instruments are being introduced
Minimal deformation
Minimal altering of length or diameter
Minimal friction between material and instrument
Adequate friction between cannula and tissue
Reasonable price

is not optimal. Hence, those flexible trocars do not exhibit optimal features.

Teflon is also used by Olympus Winter&Ibe. The flexible tube of the cannula is made of Goretex. This material is a thin foil, with pores 20000 times smaller than a drop of water and 700 times the size of a H<sub>2</sub>O molecule. Goretex film is used to line the tubes, which are very flexible. The disadvantage is that the tube is disposable because the pores cannot be cleaned sufficiently after use.

Quite soft, flexible, disposable cannulae (Ethicon; Cincinnati, OH, USA) are made from polyethylene. Their introduction is facilitated by using a trocar that can be distended within the cannula, tightly fixing it.

### Percutaneous Instruments

The “Quicksert” disposable instruments by Kinsey Nash (Nashville, TN, USA) are 3.7 mm in diameter. A piercing pin permits quasi self-seating, whereby the cannula is eliminated. These instruments include graspers, scissors and dissectors and can be reinserted without requiring additional incisions for cannulae. Thin, directly insertable instruments may provide considerable improvement in endoscopic surgical procedures and if they are reusable save costs as well. The smaller puncture sites may cause less pain and scar formation as an advantage for the patient.

### Instruments for Laparoscopic Cholangiography

Laparoscopic cholangiography usually starts with the cannulation of the cystic duct with a catheter, e.g. a 4–5 Fr ureteric catheter. After the catheter has been inserted through the small incision into the cystic duct, Heister’s valve is passed into the common bile duct [30, 74].

The surgeon can choose from a variety of forceps. These forceps, originally designed for urological procedures, combine a small instrument channel and grasping jaws at the distal end (Fig. 1.36). When approximated these jaws keep the cystic duct watertight as the catheter is impacted. However, all these forceps are delicate and break easily if not maintained adequately and it is hardly possible to clean them sufficiently.

Insertion of the catheter into the incision can be facilitated by using a preshaped, bent catheter guiding sleeve (Rüsch; Kernlen, Germany). The deflection can be adjusted by moving the sleeve back and forth within the outer tube (Fig. 1.37a). A guide wire can be used; however, this is usually unnecessary. Marks at the catheter’s tip permit a precise introduction depth of 2–3 cm. The catheter can be temporarily anchored to the cystic duct by a slightly approximated titanium Ligaclip.

**Fig. 1.36.** Forceps for intraoperative cholangiography consist of a small instrument channel and grasping jaws at the distal opening of the channel



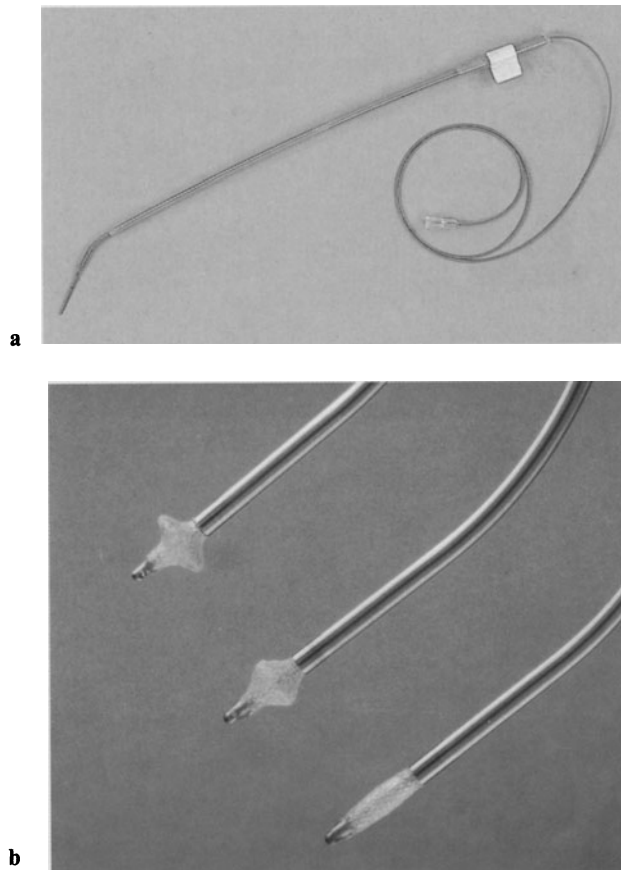

**Fig. 1.37.** **a** The preformed guiding sleeve (Tübingen and Rüschi, Kernen, Germany) facilitates the guidance of the conventional radiology catheter into the cystic duct. **b** Catheters manufactured by Applied Medical Resources or Origin employ a mechanical retention tip which can be adjusted via a ratchet handle

There are special catheters available in three sizes (Taut; Geneva, IL, USA) with which extravasation is prevented by a cone-shaped tip. However, these mechanically distensible cones have a small diameter, which limits their sealing capacity and hence a balloon would be an advantage. This Fogarty-like catheter is available from Arrow (Reading, PA, USA). Since a balloon catheter is employed, care has to be taken that the device is sufficiently inserted into the cystic duct. Otherwise the insufflation of the balloon pulls out the catheter. Catheters manufactured by Applied Medical Resources (Laguna Hills, CA, USA) or Origin, employ a mechanical retention tip which can be adjusted via a ratched handle (Fig. 1.37b). These rigid catheters have preformed angles, which require a separate access

or a flexible trocar. However, they reduce the need to suture or clip the catheter in place.

Another design is available from Lapromed (Irvine, CA, USA), the “PortSaver”, with which the abdominal wall can be electro-surgically penetrated. This should only be undertaken under endoscopic control from inside the abdominal cavity. The disposable “cholangiographic device” has a rectangular open tip in which a hollow needle is inserted. If the cystic duct is placed in the opening, a vacuum keeps it in place and then the needle is pushed, puncturing the duct, and contrast can be injected. This procedure will only work if the cystic duct is of a normal size and perfectly skeletonized.

## Hand Instruments

### Grip and Handle Design

Basically, the handle function can be described by coaxial and transaxial actions (Fig. 1.38a–c). Transaxial action handles are most common. The grips have finger rings and are positioned at  $90^\circ$  to the longitudinal axis. Hence, the action of fingers relative to the hand are transmitted in longitudinal movements. As a result the whole instrument moves. This unintended movement must be compensated for. However, it can be minimized when the grips are positioned in longitudinal direction. The opening actions then are  $90^\circ$  to the axis, hence, the force vector in longitudinal direction is zero.

### Ergonomic Grip Design

A unique and ergonomic design is the Polaris grip by ValleyLap/Pfizer, manufactured by DaVinci. The main advantage is that grip and shaft are modules which can be interchanged. However, the ergonomics are limited to a dedicated position, which, in fact, can only be used in a few procedures. Although, left- and right-handed users have been taken into consideration, most of the time the surgeon has to operate the handle in various positions and directions.

In order for all functions to be carried out with one hand, drives such as pneumatic cylinders or servomotors have to be considered. However, drives need switches, an energy supply, and additional

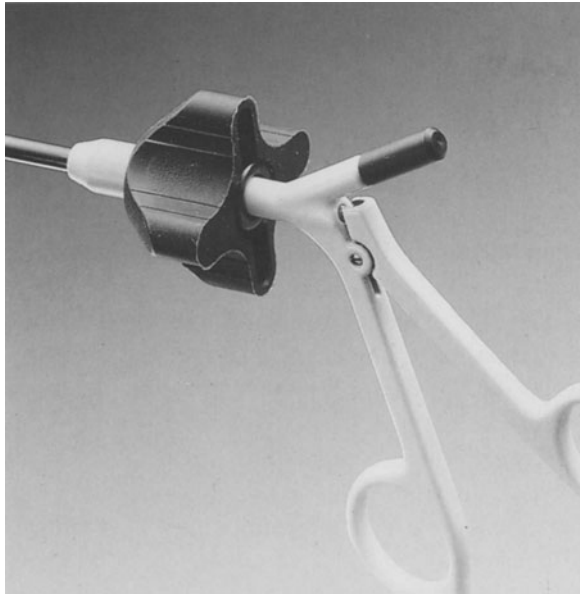
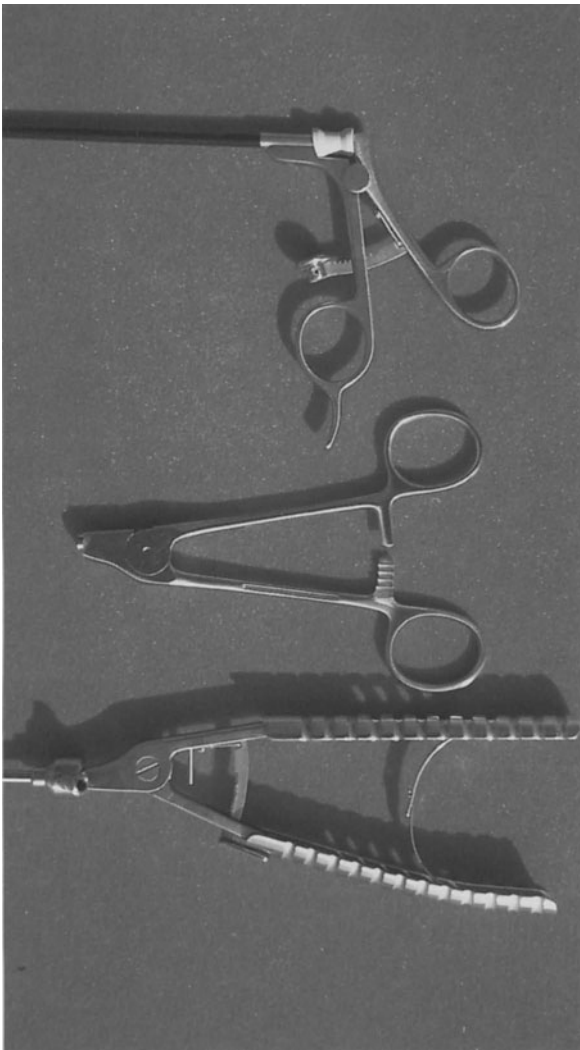
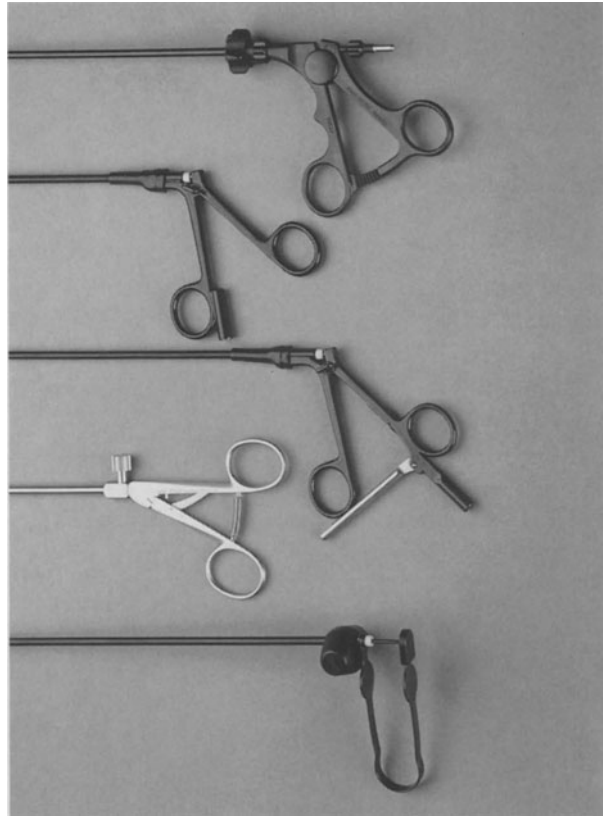

**a****b****c**

**Fig. 1.38 a–c.** Different types of handles. The principal functions can be classified into “coaxial” and “radial” action

maintenance, which increase the costs of an instrument; the priority, however, is to accomplish fast and precise operations.

## Tissue Manipulation

### Retractors

Hand instruments which provide the surgeon with adequate retraction have to meet certain requirements. First of all they have to be completely atraumatic. This is important, since the retractor tip is often outside the visual field and thus it is only controlled by sensorial feedback. The broad and smooth flanked hooks utilized in open surgery are appropriately designed for that purpose. Endoscopic retractors, however, have flanks and thin blades with relatively sharp edges (Fig. 1.39).

Only a few retractors are adequately designed. The principle is simple; pressure is force per square surface area and to reduce pressure applied to tissue, the square of the retractor has to be enlarged. Retractors made from segments with internal cables (Surgical Innovations; London, UK) are excellent as they are relatively stiff once the inner cable is strained by means of the handle. However, the cleaning of the segments is delicate and cumbersome.

An interesting concept of organ retraction is the "joy stick" by Origin. It was designed for cholecystectomy. The organ is punctured, the device inserted and then a balloon inflated. The gallbladder can be handled easily; however, the dissection is more difficult because the bladder slips around the balloon.

Considerable facilitation of organ dissection and retraction are the Dundee "variable curvature instruments" (reusable, Storz; disposable USSC; Fig. 1.40). A circular, preshaped retractor blade introduced in a straight shaft recovers once pushed out of the shaft. The instrument allows precise adjustment of the curvature. Thus retraction and mobilization are facilitated considerably [75].

### Forceps

The design of the forceps currently available is similar to that of the forceps employed in conventional

surgery. The shape of the jaws, for example, reproduces the features of De Bakey, Allis, Russian, etc. (Fig. 1.41). The small diameter restricts an optimal design. The opening distance of the jaws is limited. The length and the maximum possible force is very much reduced, whereas the stiffness is increased, which predisposes to accidental injuries. An atraumatic bowel grasping forceps, for instance, equipped with De Bakey's jaws, will cause severe damage to the tissue when the distance between the jaws close to the hinge is too narrow (Fig. 1.42a, b). Adequate opening angle and a free proximal space to protect clamped tissue from injury is most important for endoscopic forceps. One possibility to achieve large opening angles and adequate blade movements is a new hingeless type of instrument (Fig. 1.42c). The major disadvantage of the old type of hingeless graspers and bipolar forceps is the relatively longitudinal movement of the blades (Fig. 1.43a). The new hingeless instrument has an intermediate tube which approximates the blades when advanced (Fig. 1.43b). The jaws are connected with the grip, thus maintaining the jaws' position while in operation.

The superelasticity of nickel titanium alloy offers the required elasticity for hingeless instruments such as atraumatic forceps, scissors and needle holders. Superelasticity describes the property of recovering an initial shape subsequent to loading and substantial deformation. Superelastic Nitinol has an approximately ten-fold higher elastic deformability than common spring stainless steel [76, 77]. Those instruments combine adequate performance with a simple design, which facilitates the cleaning process as well as repair and maintenance.

Using superelastic materials in the production of endoscopic instruments offers important safety features:

- The graspers have a built-in pressure limit between the jaws, which reduces the risk of tissue damage.
- The needle driver has two locking positions: first lock adjusted exactly to hold the thread without damaging and second lock firm but also adjusted grip of the needle.
- The scissor blades slide with optimal elasticity along each other to facilitate excellent cutting and various curvatures.

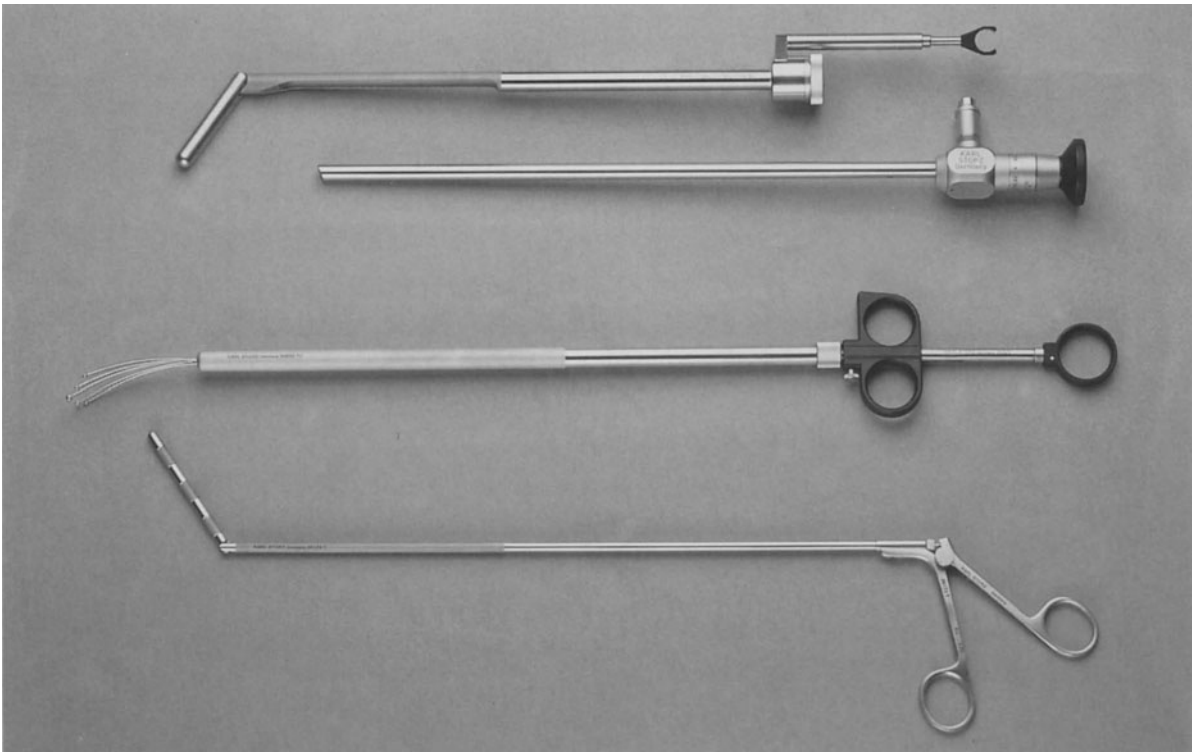

**a**



**b**

◀ **Fig. 1.39 a, b.** Variety of retractors. **a** Storz; **b** USSC

**Fig. 1.40 a, b.** Dundee “variable curvature instruments”, reusable by Storz **a** and disposable by USSC **b** employ a circular, preshaped, superelastic blade that recovers once pushed out of the shaft

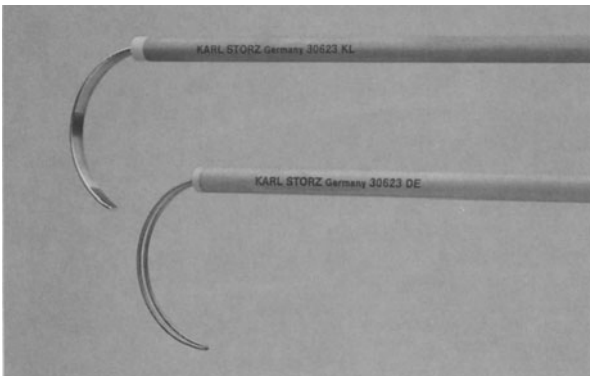

**a**

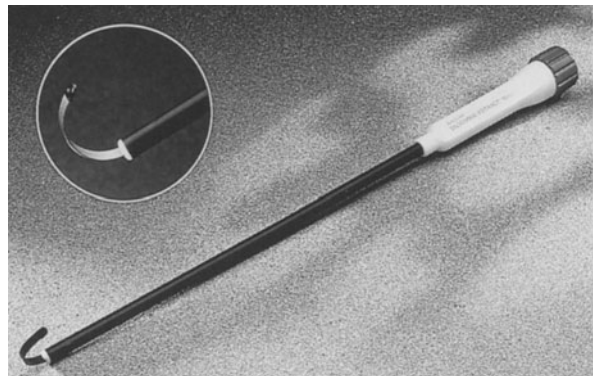

**b**

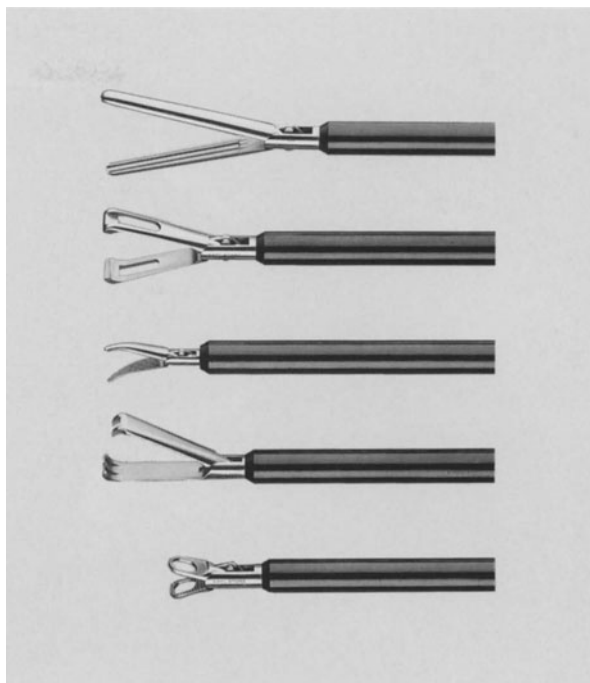
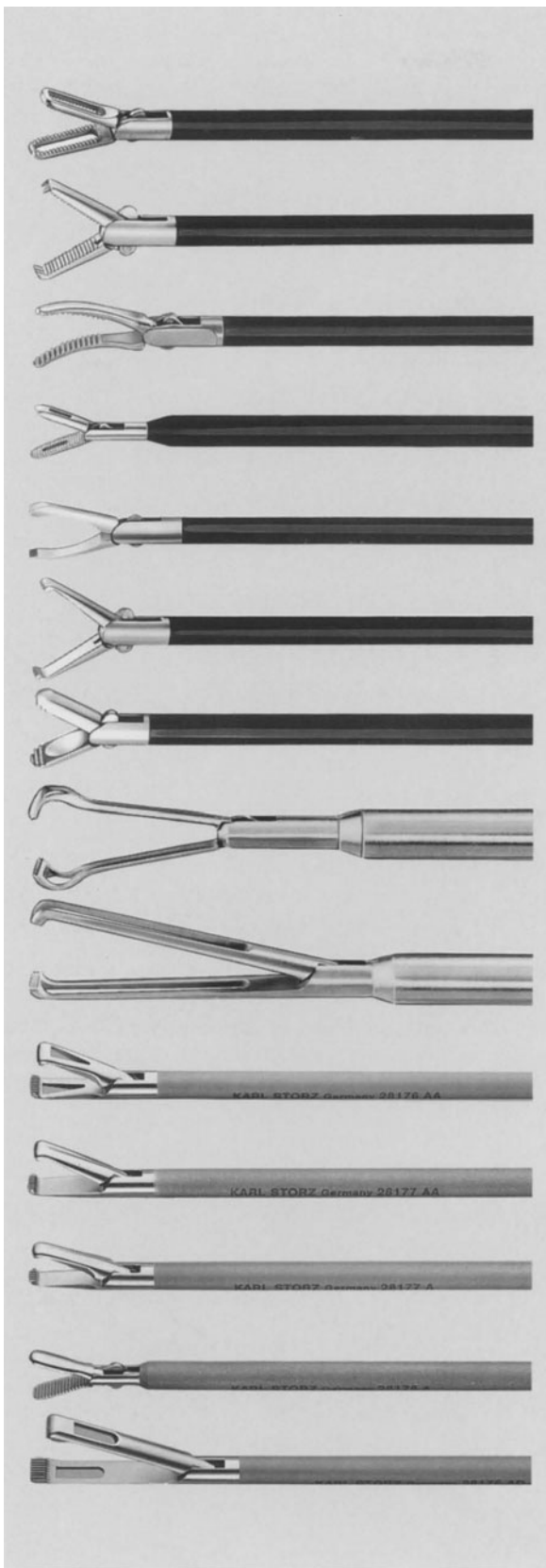

**Fig. 1.41.** The variety of types of jaws employed in endoscopic surgery

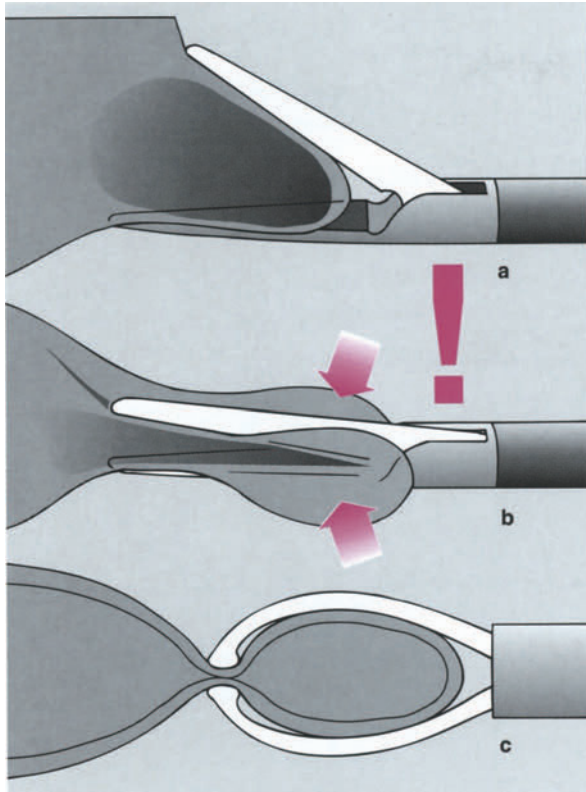

◀ Fig. 1.42. a, b A conventional forceps may cause severe damage to the tissue when the distance between the jaws proximal to the hinge is too narrow. c Adequate opening angle and a free proximal space to protect clamped tissue from injury is most important for atraumatic grasping forceps

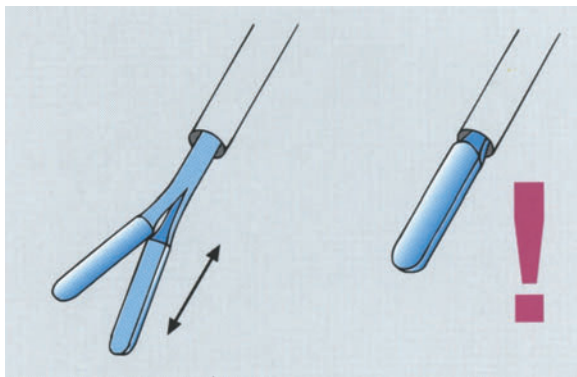

a<sub>1</sub>

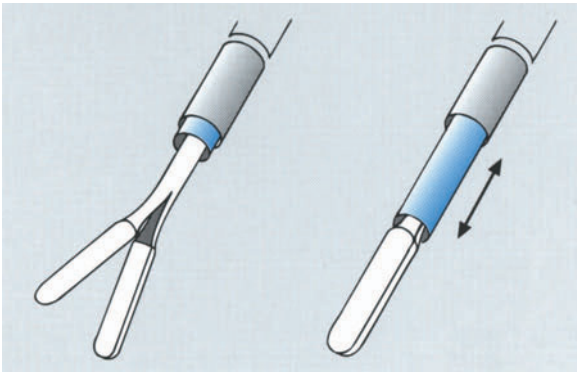

b<sub>1</sub>

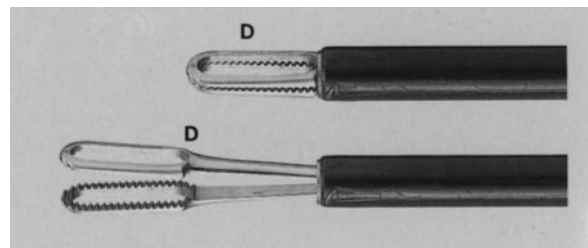

a<sub>2</sub>

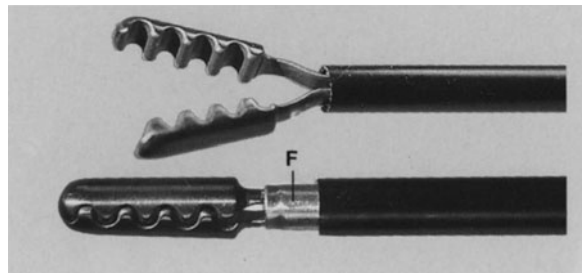

b<sub>2</sub>

▼ Fig. 1.43. a Conventional hingeless graspers and bipolar forceps entail relatively longitudinal movement of the blades while in operation, which requires compensating movement. b The new hingeless instruments (PCI and NDC) maintain the jaw position. An intermediate tube (*F*) is advanced to approximate the blades which are connected to the grip

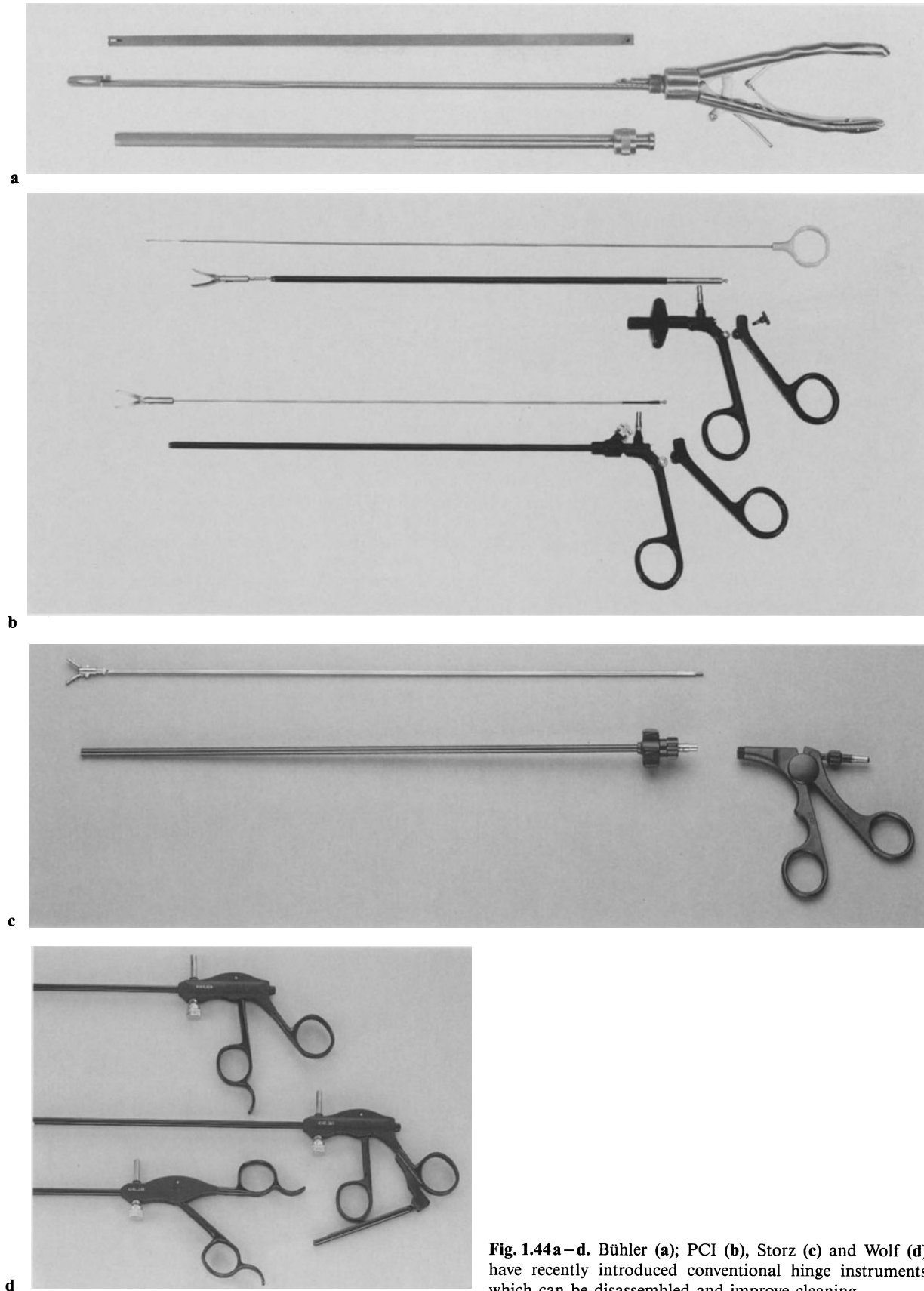

**Fig. 1.44a–d.** Bühler (a); PCI (b), Storz (c) and Wolf (d) have recently introduced conventional hinge instruments which can be disassembled and improve cleaning

For a list of the important features of instruments for endoscopic surgery see Table 1.3.

Bühler, Storz, Wolf, Circon, and PCI have recently introduced instruments which can be disassembled by unscrewing and disconnecting the push rod with the jaws from the outer sleeve (Fig. 1.44a–d). Most manufacturers offer similarly designed instruments.

Principally, the disassembling permits efficient and usable cleaning prior to sterilization. Furthermore, the functional tip can be replaced when it has worn out. Although cleaning feasibility is improved, this design has weakened the instrument.

### Curved Instruments

Curved and bayonet instruments were developed for endoluminal rectal surgery (see Vol. 1, Chap. 25). The narrow operative field requires distally curved forceps, suction probes and needle holders.

For delicate handling of internal organs in advanced laparoscopic surgery, e.g. colonic resections [78] or fundoplication (see Vol. 1, Chap. 23), additional movements and degrees of freedom of the instrument tip are needed. The limited space and movements of the instruments within the thoracic cavity further underlines the need for such equipment. This can be accomplished by simple distal curvature of the instrument (Fig. 1.45a) [79]. The distal curvature should have a radius of about 25 mm and 45° up to 60° for thoracoscopic interventions and antireflux surgery. Colonic surgery requires a curvature of up to 90°. Figure 1.45b presents a variety of curved instruments. The handling of bent instruments requires some experience because the instrument tip is moving along a circle as the long axis if the instrument is rotated (Fig. 1.45c, d).

To introduce curved instruments flexible canulae are needed. Although curved instruments increase the working area, the degrees of possible distal movement are still restricted to translation, rotation and some movements within the access port.

**Table 1.3.** Features required for instruments for endoscopic surgery

---

The instrument position should be stable when the jaws are activated.
The jaws should be adequately elastic so as to permit atraumatic grasping and other jaws functions.
The instrument should be easy to disassemble and reassemble.
The modules should be designed with similar interfaces so that an exchange is possible.
The outer sleeve (insulation) should be replaced easily.
The standardized interface should be connected to cleaning and rinsing devices.
A functional check of all parts should be easy and automatically takes place on each application.
The manufacturer should use a minimal number of parts, which reduces cost and should provide the surgeon with upgrades of the jaw design at a reasonable price.
The simple design for jaw action makes it possible to update the jaw design according to new applications.
The manufacturer should provide the surgeon with all parts so that in case of weakness or breakage only the defective component has to be replaced.
A simple design reduces wear and tear because the number of hinges and bolts are reduced.

---

### Variable Curvature Instruments

A more sophisticated solution is to use steerable, distally deflecting instruments. There are some instruments currently available which allow the transposition of the jaws' action mechanism (Micro France, Paris, France). However, when the jaws are deflected to 90° there is no residual opening angle.

The superelastic property of nickel-titanium is used for the variable curvature spatula and sling passer (Storz) (Fig. 1.40) and in the disposable, variable curvature forceps (USSC). The latter consists of a preshaped Nitinol tube covered by PTFE. The curvature is adjusted by shifting the outer sleeve. The price for the variable curvature is reduced stiffness of the curved part of the forceps. However, it is a useful design which enhances the scope of endoscopic manipulations. USSC is marketing the first deflectable instruments. The disposable rotulator generation incorporates superelastic Nitinol tubes. Although these instruments permit continuous adjustment of the distal end from 0° to 90°, their mechanical stability should be increased.

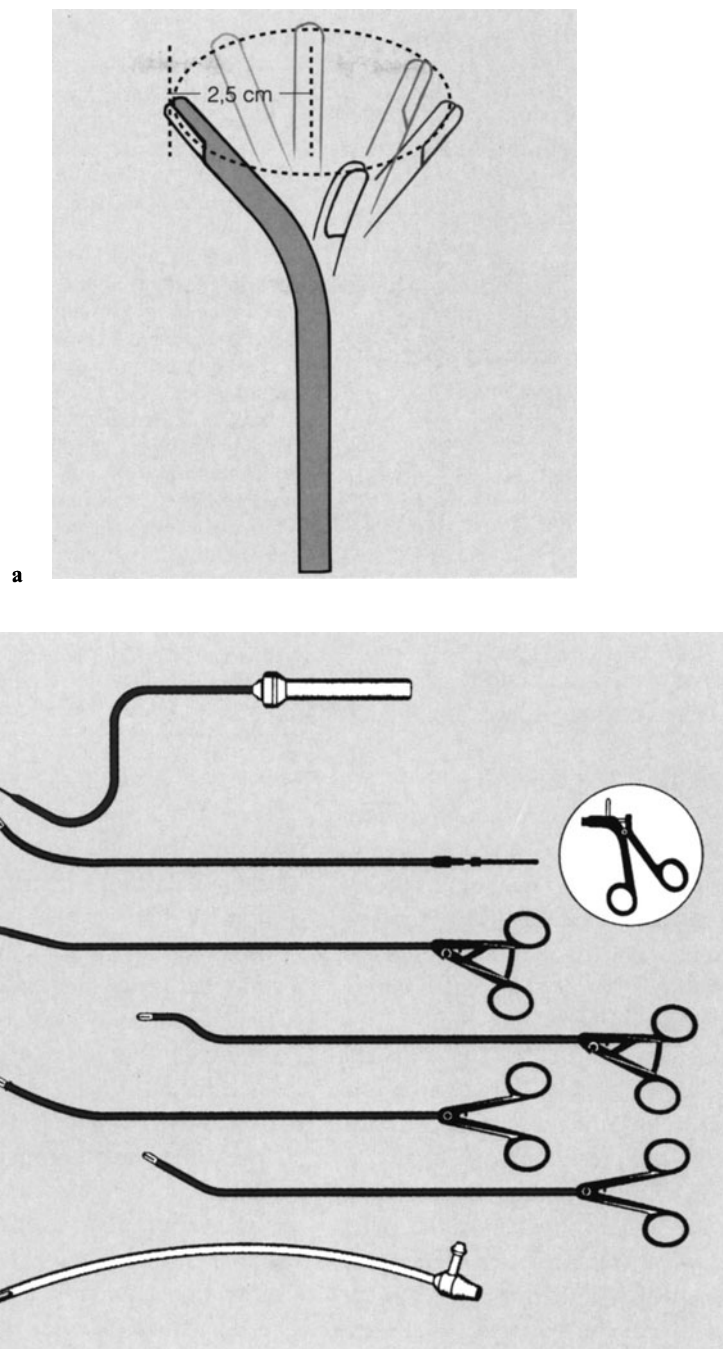

**Fig. 1.45.** **a** The ideal circle (radius of 25 mm) that is described by rotation of the functional tip of curved instruments. **b** A variety of available curved instruments (Olympus Winter&Ibe). **c** The geometry which is described by the possible movements of the functional tip of straight instru-

ments within the endoscopic operative field. **d** The handling of curved instruments requires additional training due to the complex geometry which is described by the movements of the functional tip



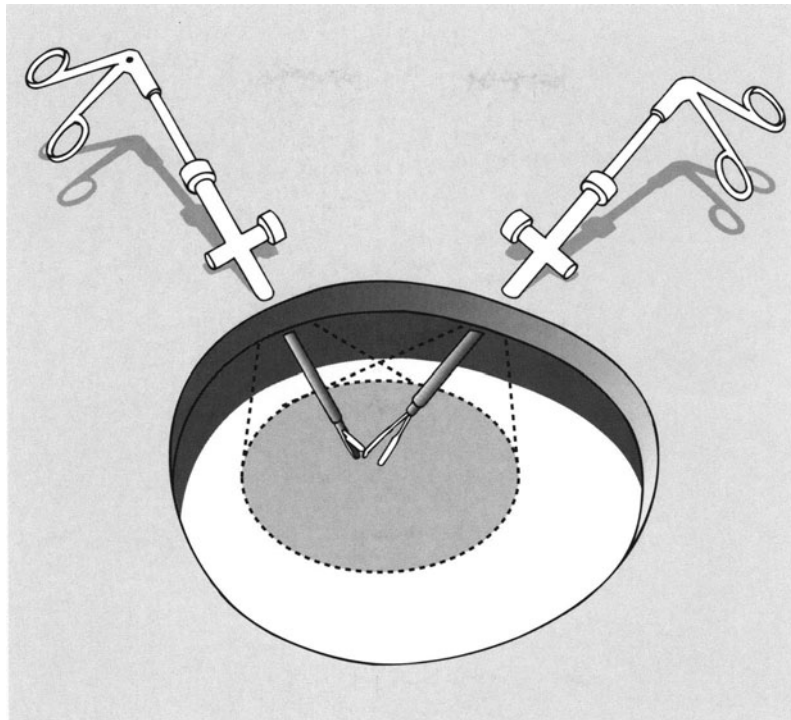

c

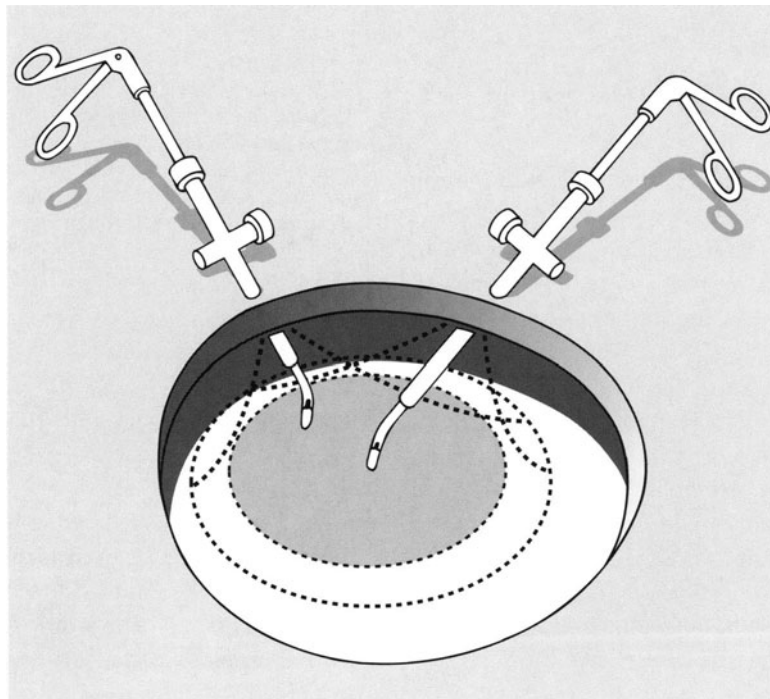

d

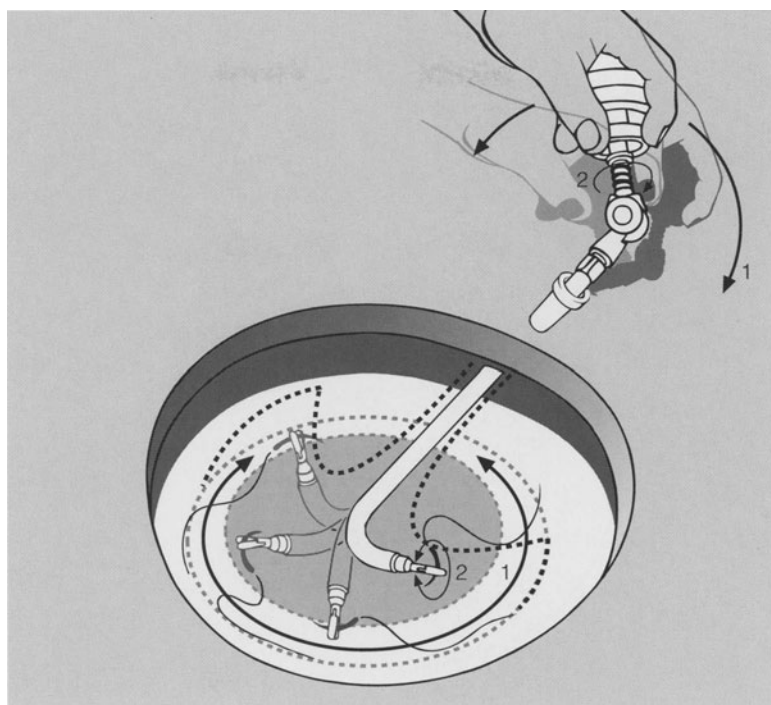

### Dextrous Instruments

In our experimental experience a steerable dextrous instrument should include two additional movements of the distal part [79, 80]: deflection of the tip by  $\pm 120^\circ$  and rotation of the tip while it is deflected (Fig. 1.46). A prototype of such an instrument has been developed in co-operation with the Nuclear Research Centre, Karlsruhe, Germany, and has been tested in animal experiments. It is a simple mechanical manipulator [81]. Although our experience indicates that steerable dextrous instruments facilitate endoscopic manipulation, their handling requires considerable training. Due to the various geometric configurations of the tip of dextrous instruments, their handling is more delicate than that of simple curved instruments. Once the surgeon is familiar with a specific curvature or angle of the shaft, he can correctly perform converted movements. Variable distal curvatures during endoscopic operations increase orientation problems. The integration of energetic drive such as pneumatic elements or servomotors will enhance the applicability of dextrous instruments [79, 80].

**Fig. 1.46.** The first prototype of a dextrous instrument (Tübingen and KfK, Karlsruhe, Germany). Two additional degrees of freedom of the functional tip (1, 2) are controlled outside by movements of the handle which are directly transmitted via cables through the shaft to the tip

### Mechanical Dissection

New types of scissors with tungsten inlets and remarkable cutting facilities have been developed (Aesculap; Fig. 1.47 a).

Because there are no long-term sharp, reusable scissors which can be used with HF disposable scissors, such as the Endoshears by USSC are widely used (Fig. 1.47 b). Improved designs are available from Everest Medical (Minneapolis, MN, USA); here ceramic blades have been incorporated in disposable bipolar scissors. Ceramic provides superior cutting, but it is expensive and should therefore be considered as a material for reusable scissors.

Principally, bipolar HF coagulation is preferable to monopolar diathermy due to the reduced risk of unintended side effects.

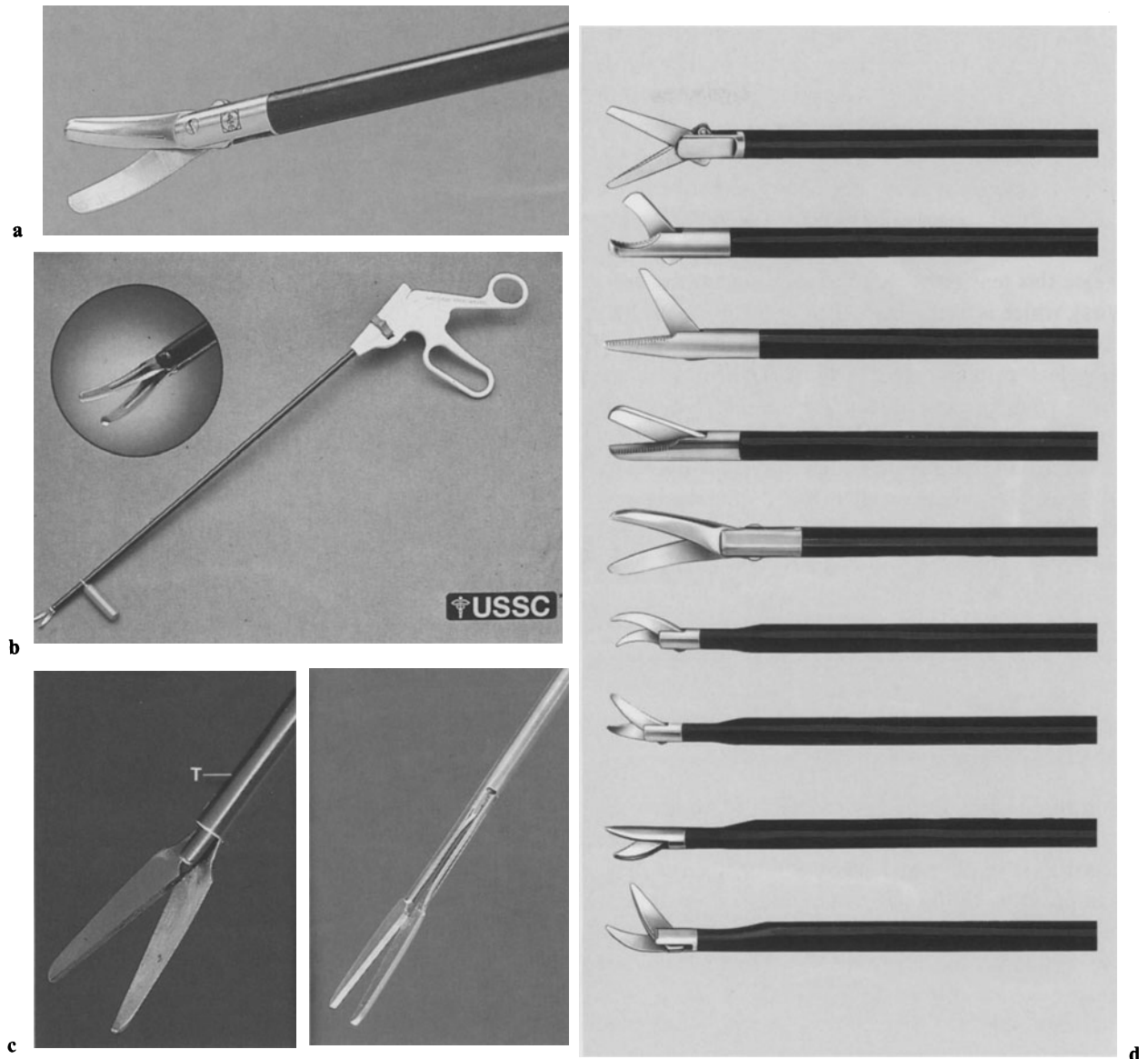

**Fig. 1.47.** **a** Aesculap (Tuttlingen, Germany) markets scissors with tungsten inlets in the blades which provide remarkable cutting capability. **b** Disposable scissors such as the Endoshears (USSC) should not be reused due to inadequate cleaning and functional mishaps subsequent to sterilization. **c** Re-posable hingeless scissors are made from one piece

(superelastic Nitinol or stainless steel). The reposable blades are approximated by means of an intermediate tube (*T*) that is advanced by the grip. Shaft and handle are fully reusable (PCI, NDC). **d** Range of reusable scissors

A principal problem of endoscopic scissors is caused by the short length of the blades. The tissue cannot be divided with the same precision as with conventional scissors used in open surgery. The major prerequisite of the ideal scissors is the tension with which the blades slide along each other. In conventional scissors this is achieved by the length of the branches. Some manufacturers have tried to create this tension with a screw (Metzenbaum scissors), which is useful but delicate. A simple but reliable scissors can be produced according to the hingeless principle (Fig. 1.47c). The scissors are made from one piece (e.g. superelastic Nitinol or stainless steel). The blades are approximated by means of an intermediate tube that is advanced by the grip. The jaws open again due to their elasticity, which provides the feature of the conventional scissors: the blades slides along each other. This enhances the cutting considerably. As the jaws are in one piece with the central rod they can be replaced easily at a reasonable cost (PCI, Liptingen, Germany).

### Tissue Approximation

Suturing is one of the key problems of endoscopic surgery. The remote technique of handling needle and thread with two instruments is considerably hampered by the length and rigidity of the instruments. It is difficult to achieve the correct needle position in the jaws or to drive it through the tissue in any desired direction.

Improved, "ski"-shaped needles with a flattened cross-section (Dundee) have been developed which can be easily erected by simply grasping them (Fig. 1.48a). The flat cross-section has another advantage: the lock is improved, which increases the fixation within the jaws. This form lock is very important for the spring-loaded needle holder without a locking mechanism. The better the form lock, the better the needle remains in position. Technically, the best congruence between jaw shape and needle cross-section is a triangular needle and prism grooves in the jaw (Fig. 1.48b). However, with such a design the thread may be damaged. The best compromise would be a diamond-dusted inner surface of jaws with smooth edges.

The needle holder from transanal endoscopic microsurgery (Wolf) has congruently concave-con-

vex-shaped jaws that automatically swivel a curved needle into upright position (Fig. 1.48c). Endoscopic suturing is facilitated with these instruments.

With the Cook needle holder curved needles are automatically set into upright position (Fig. 1.48d). However, only one needle position is possible with a particular type of the Cook holder. The difficulty of internal handling of the thread to make a knot is a major disadvantage.

Some needle drivers entail spring-loaded approximation of the jaws. Although high spring force provides excellent fixation of the needle, opening of the jaws requires additional force.

To improve the delicate handling of both the grip and the locking mechanism classical and novel design features have been introduced. The most advanced mechanism created by Wolf (Fig. 1.48e) involves telescopic locking which functions like a ball-point pen: one pressing locks and the next releases the grip. Unfortunately, the mechanism cannot be disassembled, which hinders complete and easy cleaning.

The new needle holder by MBG (Gembloux, Belgium) probably has the firmest gripping of the holders available. Its principle is quite simple; it consists of a tube and a pushrod and two tungsten metal rings which are simply pressed against each other (Fig. 1.48f). There are two major disadvantages to the design: it is difficult to tie a knot, because the tip is too long and the opening depth of jaws is reduced due to the central rod. Hence, the grasping of the thread is difficult. A monofilament suture when gripped with the rings is likely to be damaged. Handling of needle and thread is more practical with the conventional needle holder than with the one made by MBG. Although the MBG design is novel and fascinating it needs some practical refinements and improvements to facilitate cleaning after usage.

Z. Szabo and G. Berci have designed two instruments, the parrot and the flamingo forceps (Fig. 1.48g) [82], which permit excellent execution of internal suturing and knotting. Although, the handling is not optimal, the congruently shaped jaws of the instruments facilitate grasping and positioning of needle and thread. It must be stressed that the grasping of any suture with all available tungsten-reinforced holders, with the exception the

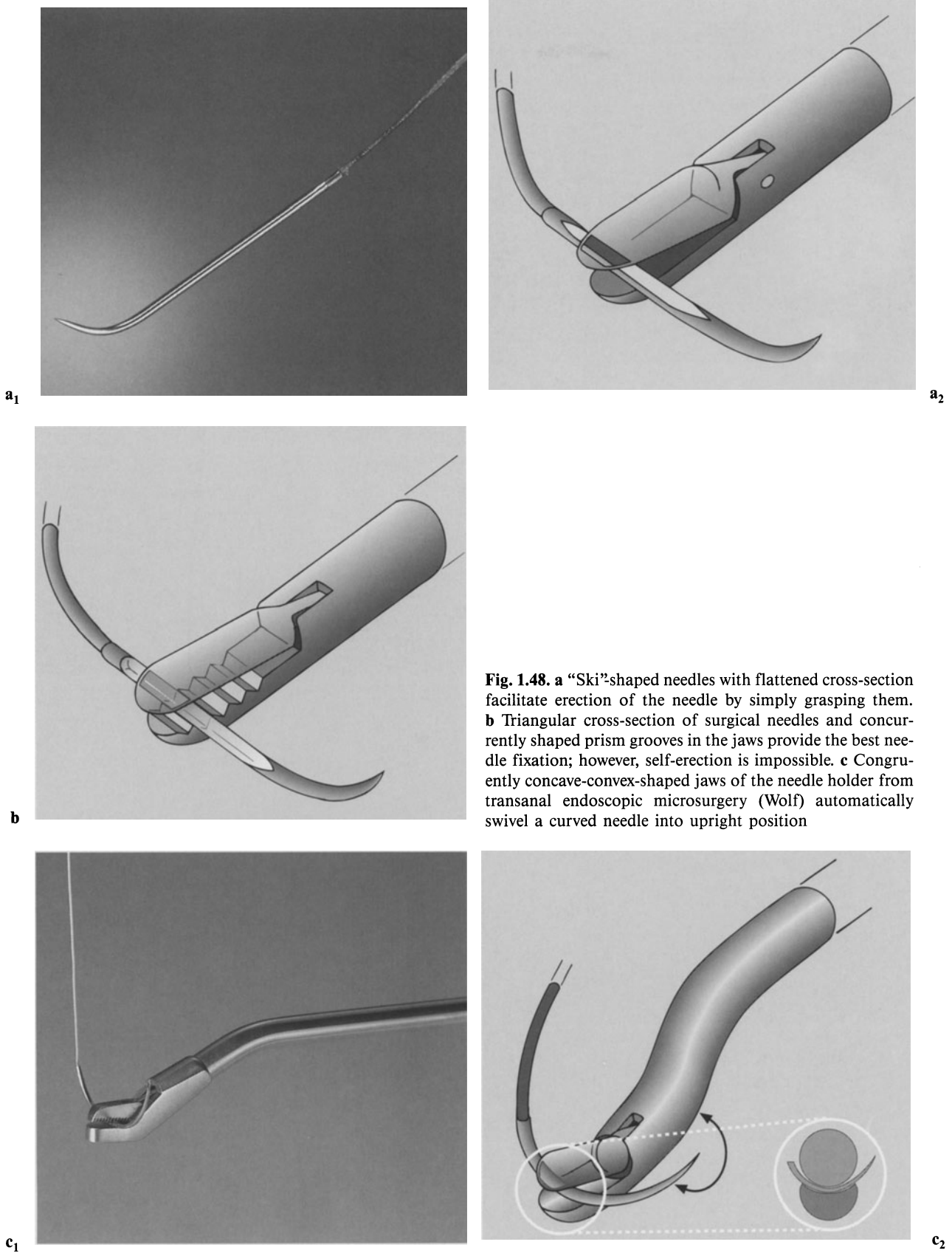

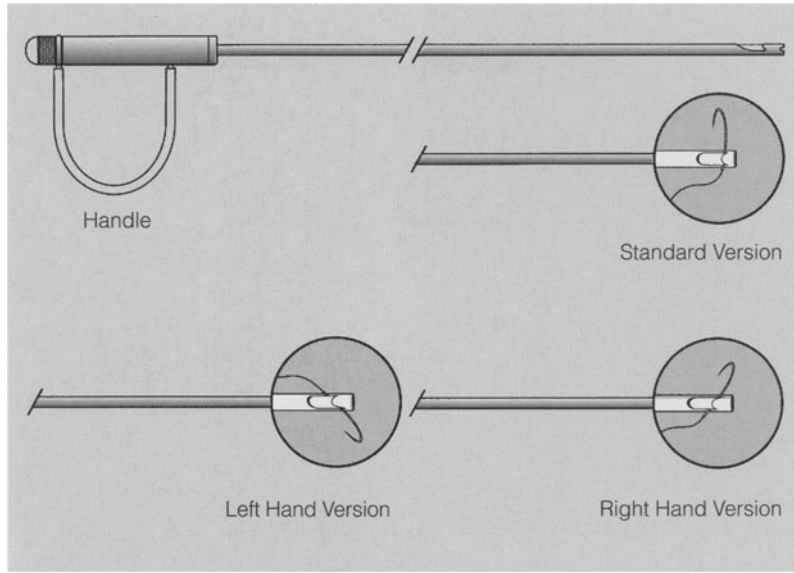

d

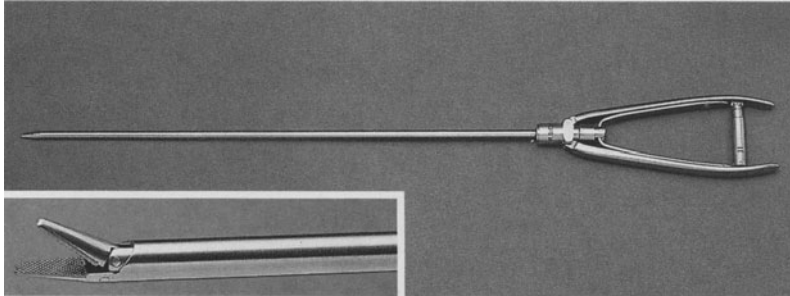

e

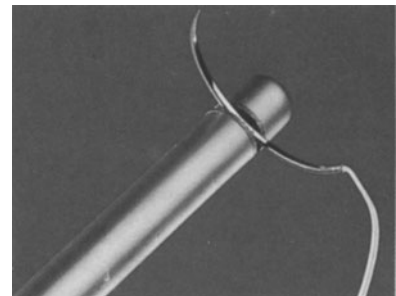

f

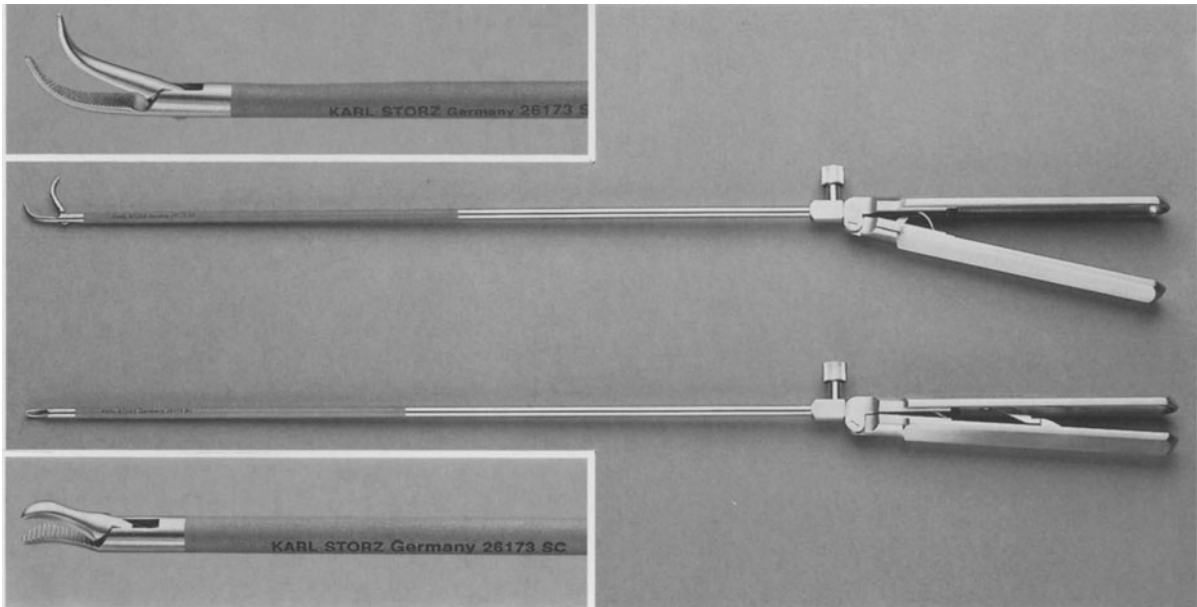

g

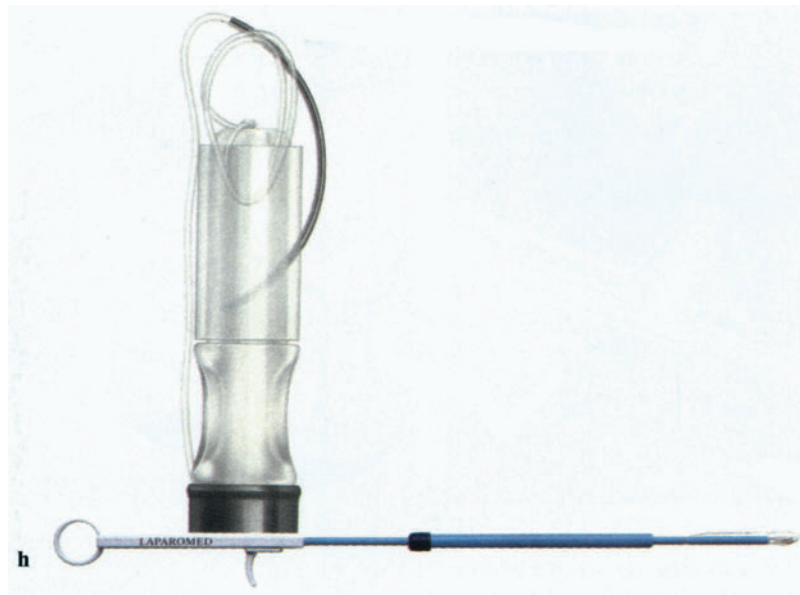

**Fig. 1.48. d** The Cook needle holder automatically sets curved needles into a predetermined position but grasping a thread is difficult. **e** Wolf markets a needle holder with a locking mechanism that functions like a ballpoint pen: one pressing locks and the next releases the grip. **f** The needle holder from a Belgian company (MBG) consists of a tube and a pushrod equipped with tungsten metal rings which are simply pressed against each other. Although needle hold is excellent, grasping a thread is difficult. **g** The “parrot” and the “flamingo” forceps designed by Szabo and Berci (Storz) facilitates internal suturing and knotting. **h** A disposable suture applier (Lapromed) consists of a needle, suture, pretied knot and applicator. Subsequent to suture the needle is simply led through those two loops and the knot then fastened from outside

rubber-shod holder, may lead to severe damage to the structure of the suture with subsequent breakage.

A disposable suture applier (Lapromed) consists of a needle, suture, pretied knot and applicator. The needle with the thread is stored in the tip of the device. After introduction the needle can be grasped. It is attached to a 15-cm-long thread. The knot is pretied and two loops are exposed at the tip of the shaft. To make these slip knots the needle is simply led through those two loops and the knot can then be fastened from outside by means of a retaining band (Fig. 1.48h). This suture applier is useful for the application of one single knot. If, however, several knots are required, the device increases costs considerably. It has the advantage that

the surgeon does not have to cope with external slip knots.

### Complex Suturing Devices

Our experimental work on suturing has led to the development of a new sewing device [83]. A needle holder designed in collaboration with the gynaecologist B. Klemm allows movement from one jaw to the other, which has some advantages in the handling of the needle. The needle can be positioned appropriately by moving the jaw in a longitudinal direction.

### Sewing Devices

The shuttle needle and its applicator are almost like a real sewing machine. They were developed by the Tübingen group in collaboration with the Nuclear Research Centre in Karlsruhe, Germany, from 1989 to 1991. With this device a needle can be transferred between two jaws, similar to the sewing shuttle employed in weaving looms. The shuttle needle has a central cross bore for the thread and two trocar point tips (Fig. 1.49a–d). It can be transferred between the jaws of the instrument and is intermittently docked to miniaturized grip elements

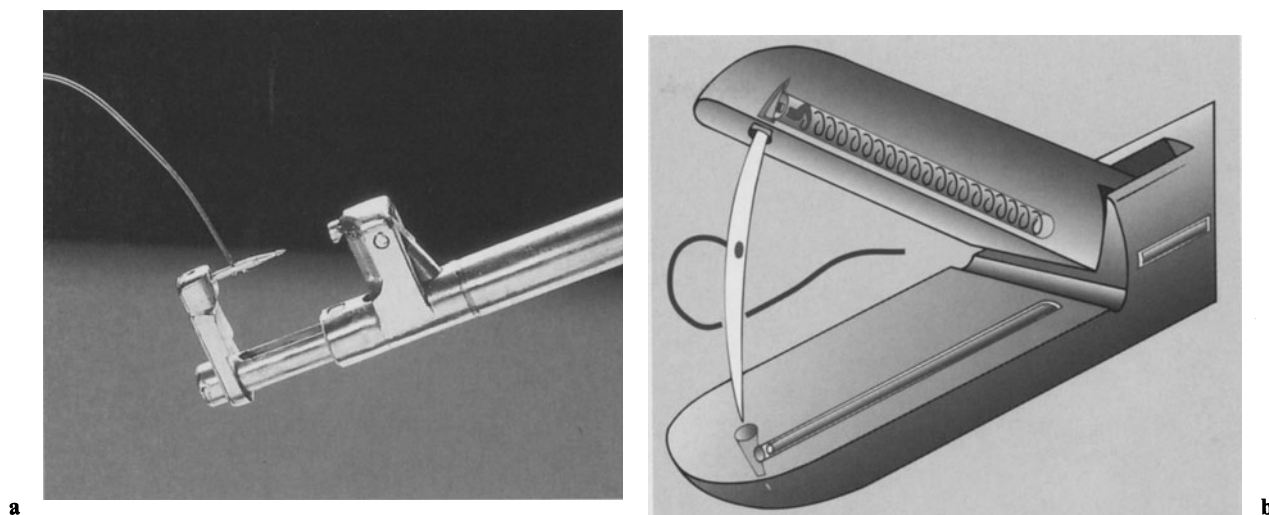
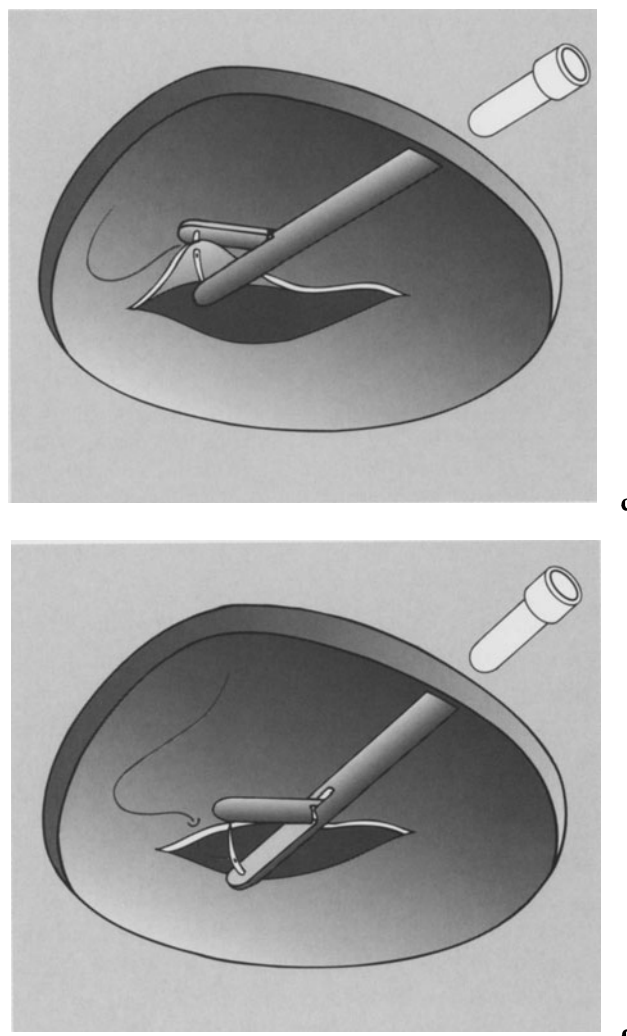

**Fig. 1.49.** **a** Photo and **b** diagrammatic representation of the “shuttle needle” device that allows the transfer of a “T-Needle” between the two jaws of the instrument by means of a spring-loaded gripping element within the moveable jaw and gripping element located in the opposite jaw which can be pneumatically operated from outside. **c** The “T-Needle” is stitched through the tissue into the opening funnel of the gripping element. **d** The needle remains in the locked gripper and the thread led through the stitch channel

integrated in the jaws by an active pneumatic gripper controlled by a foot switch. The other gripper is a passive, spring-loaded attachment. If the needle is held with the pneumatic gripper, the force of the spring-loaded grip is overcome and the needle is held in the pneumatic grip. If this grip is released, the needle is fixed in the spring-loaded grip. The elaborate handling of the needle with two holders is no longer required and the transfer can also be used to tie a knot. Different shapes and cross-sections of the needle and two transfer directions “vertical” and “axial” have been designed and tested. The shuttle needle facilitates endoscopic suturing. The device is now marked as “Endostich” by USSC.

### Ligating Instruments

The execution of a ligature with thread requires delicate handling with two forceps to pass the tie around the vessel and the creation of an external slip knot. Although the tie can be appropriately passed using curved instruments, the development of instruments especially for ligature is important.





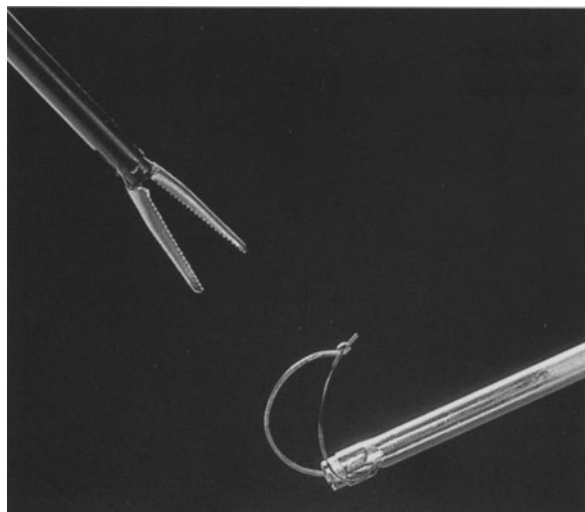

**Fig. 1.50.** Ligating is facilitated by using a superelastic Nitinol wire which permits the passage of a thread surrounding the pedicle. (EndoLig)

The passage of the thread around a vessel can be facilitated using superelastic material, e.g. Nitinol. In Fig. 1.50 the thread is passed with a superelastic wire surround the pedicle. Nitinol wire, which features stress-induced martensitic phase transformation, can be preshaped using special heat treatment. It can then be introduced in a restraining tube. When extruded it recovers its preformed curved shape [76, 77]. Thread can be inserted through a needle eye at the distal end and then passed around a pedicle. The thread is subsequently grasped by a forceps and the ligature then finished with an external slip knot or a knot clip.

A device similar to the above-mentioned EndoLig is the sling passer by Storz (Fig. 1.40a).

#### Classic Ligature with Tandem Forceps (Endo-overholt)

This instrument works in accordance with the ligature technique of open surgery. Two graspers are inserted in separate channels contained within one port. In between them is a moveable scalpel which can be controlled from outside. Both handles of the graspers are interconnected. Two additional channels carry two pretied polydioxanone (PDS) loops, each with its own plastic pusher. The loops are placed so that each surrounds the forceps tips on

either side (see Vol. 3). After the vascular pedicle is mobilized, it is grasped by the two forceps and then carefully divided by extrusion of the knife. After the knife is retracted the loops are pushed forward such that they surround the vascular pedicle and are then firmly tightened. This procedure is faster than standard endoscopic ligature using external slip knots.

#### Knot Pushers

Numerous knot pushers have been designed for endoscopy since the push rod was popularized by Semm. Most of the reusable knot pushers have grooves, small terminal slits or forks (Fig. 1.51a), and all of them tend to lose the thread when the knot is pushed down. All disposable pushers consist of a simple plastic tube. Although, it is impossible to lose the thread, reinserting a thread through the long rod is difficult.

A suitable reusable knot pusher should have a terminal concavity at its distal end to accommodate the knot in position. Insertion is then easy and the tie cannot slip off. To save time, for reproducible, safe cutting of the thread and to avoid slipping of the knot, an outer sleeve can be employed to cut the thread immediately after it is tightened (Fig. 1.51b,c). Such a cutting knot pusher is available from PCI.

#### Knot Substitutes

It is possible to replace external slip knots by knot clips [84]. However, the silver clip used in transrectal microsurgery (Fig. 1.52a) is not appropriate as an implant in laparoscopic or thoracoscopic surgery. The Lapraty knot clip (Ethicon; Fig. 1.52b) is made of bioabsorbable PDS and can therefore be used in various situations, but involves additional costs. The friction of the Lapraty is only suitable when pressed on size 3–0 polyfilament thread, for example start and end of a running suture. The Lapraty knot clip should be improved so that two threads could be fixed simultaneously, which would add applicability to interrupted sutures and ligatures. However, a properly tied external slip knot is the safest and most reliable way of performing a li-

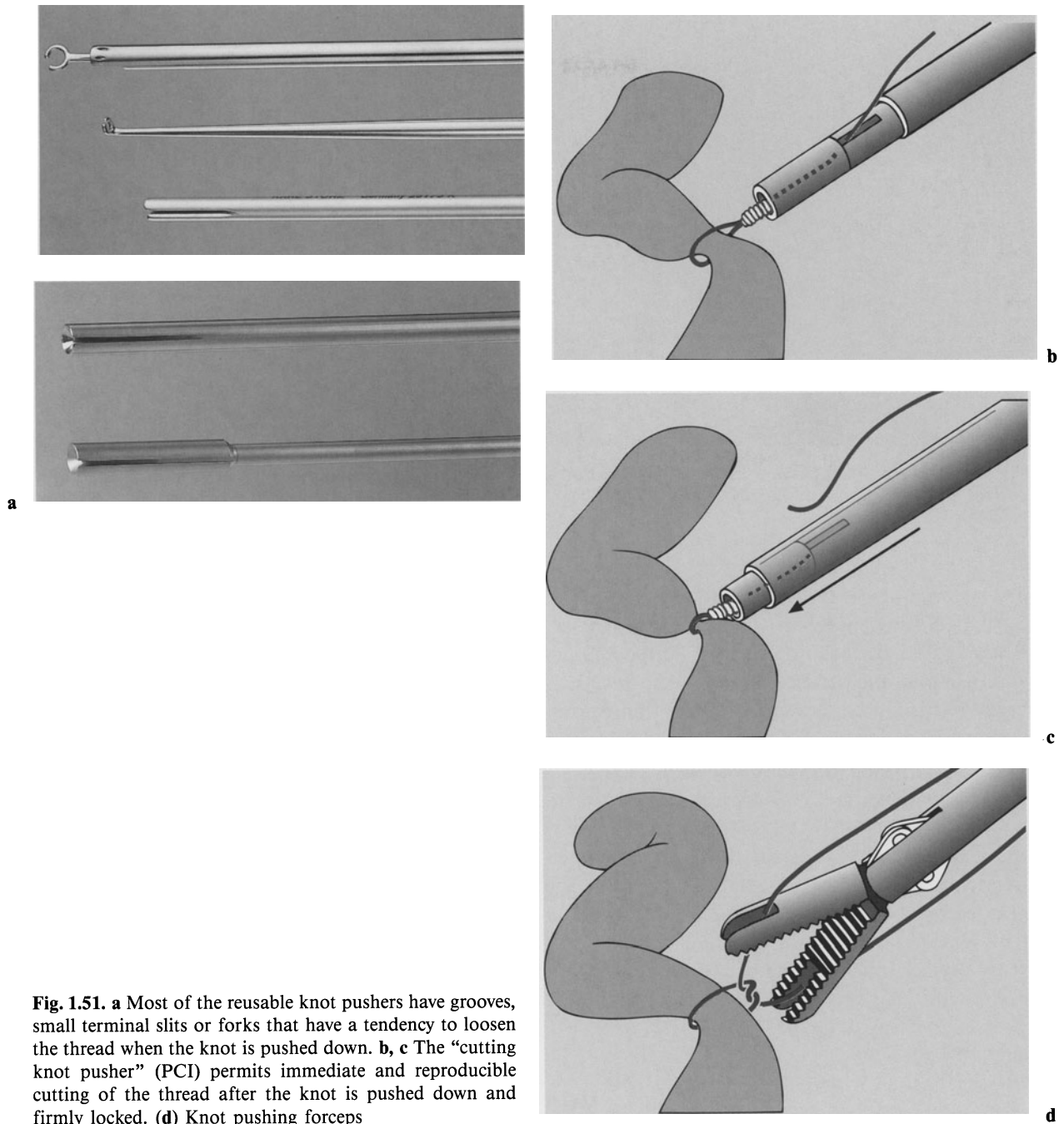

**Fig. 1.51.** **a** Most of the reusable knot pushers have grooves, small terminal slits or forks that have a tendency to loosen the thread when the knot is pushed down. **b, c** The “cutting knot pusher” (PCI) permits immediate and reproducible cutting of the thread after the knot is pushed down and firmly locked. **(d)** Knot pushing forceps

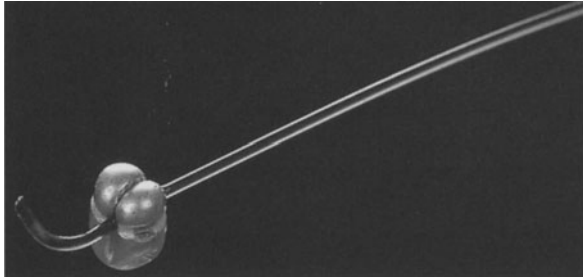
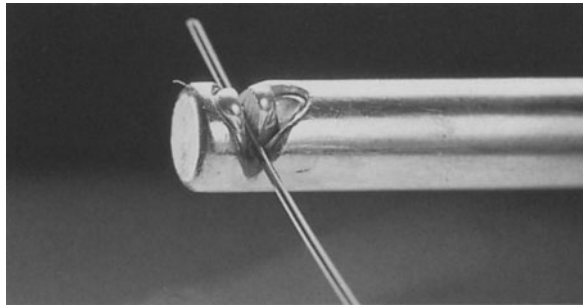

a

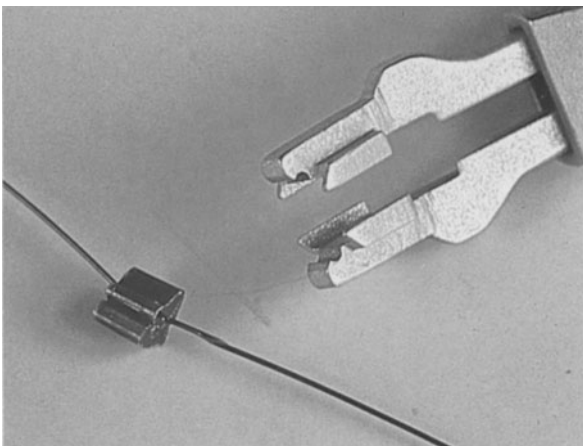
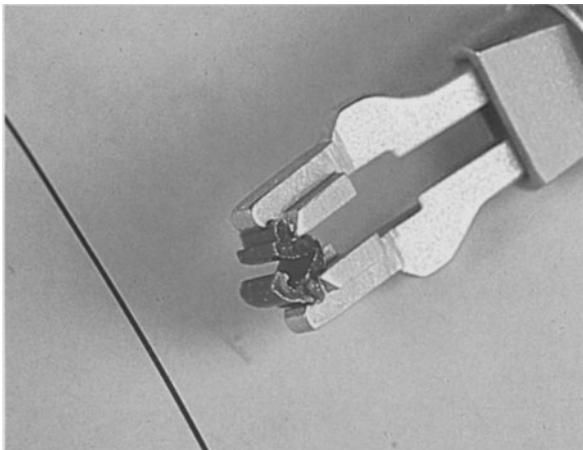

b

**Fig. 1.52.** **a** Silver clips are used as knot substitutes in transrectal endoscopic microsurgery (Wolf). **b** Knot clips, Lapraty, made from PDS (polydioxanone) are only suitable for 3:0 PDS to substitute the knots of a running suture (Ethicon; Sommerville, NJ, USA)

gature, although clumsy and time consuming. Electronic tension metering has revealed that only two tying techniques provide sufficient resistance to reverse slipping (up to 40 Newton): the Tayside knot according to Cuschieri for braided non-absorbable, and absorbable material including polydioxanone and lactomen-copolymer (Fig. 1.53 a) and others, and the Melzer knot for PDS II (Fig. 1.53 b).

### Clips and Clip Appliers

#### Ligature Clips

The traditional titanium and the absorbable (Absolock) ligature clips still have some disadvantages. The main problem is their weak grip after application to a pedicle. These clips can slip off easily, especially when they are brushed accidentally during manipulations. However, ligature clips are acceptable for small pedicles, provided they are applied precisely.

The ligature clip produced by Origin works on the principles of the ligature clips of open surgery. The arc-shaped clip captures the pedicle when its tips come in contact prior to full closure (Fig. 1.54 a). The rectangular, hook-like orientation of the clips and applicator provides improved control of the actual clipping process.

A new absorbable “lapro clip” consisting of two parts has been introduced by Davis + Geck (Wayne, NJ, USA) (Fig. 1.54 b). The relatively elastic inner member (polyglyconate) is approximated prior to full closure so that the pedicle can be grasped. Subsequently, the rigid outer member (polyglycolic acid) is pushed over the inner member and thus the clip completely and firmly locked. Each clip is mounted into a complete tip of the forceps, which is disposable, whereas handle and shaft are reusable parts.

The new Hem-lock-clip by Linvatec Weck (Largo, FL, USA) shows some principal improvements. The locking ends provides excellent tissue penetration and the fixation at the tissue is improved due to the concave-convex shape of the branches. This clip is nonabsorbable, which lowers its value. Further testing of these clips is necessary before final clinical application. As all metals more or less interfere with imaging procedures such as CT and MRI, clips made from synthetic material are preferable.

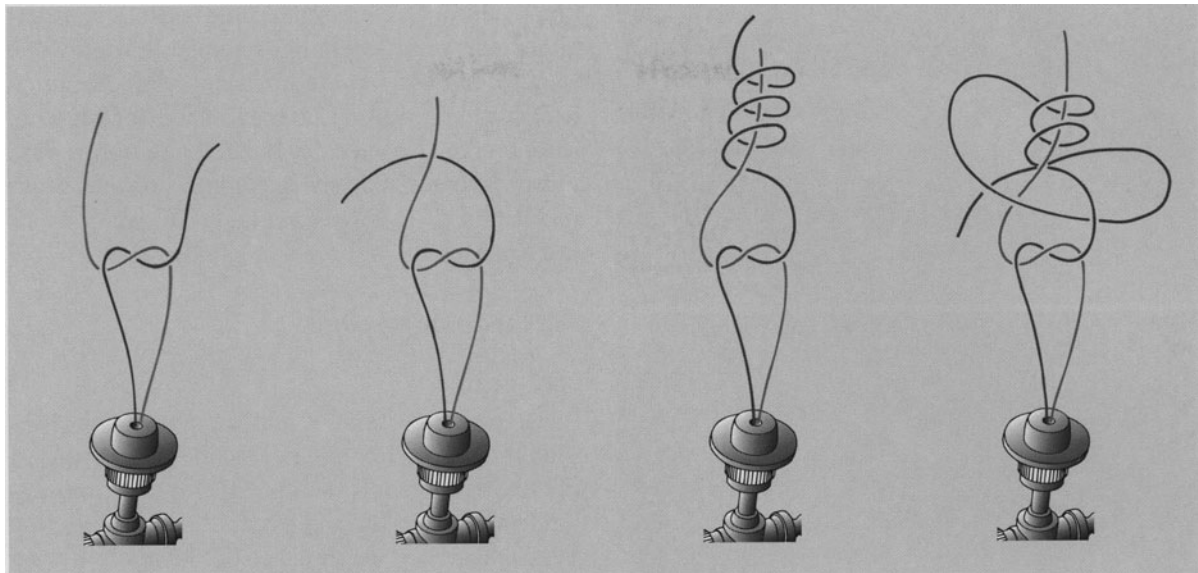

a

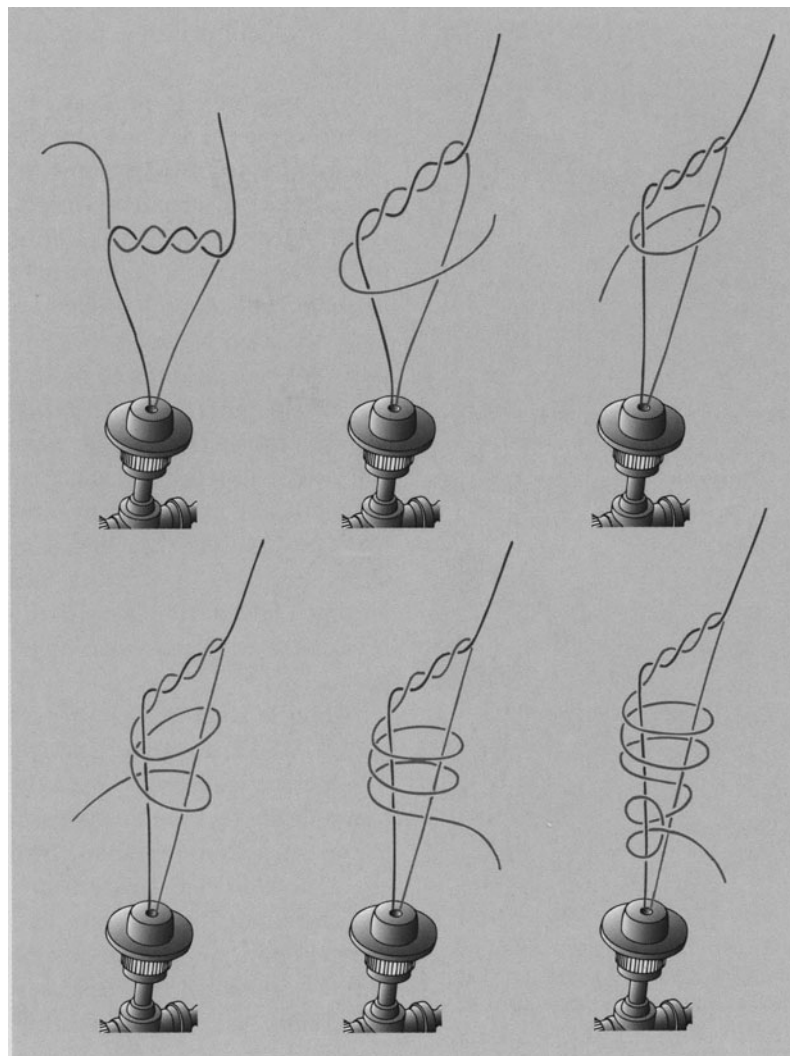

b

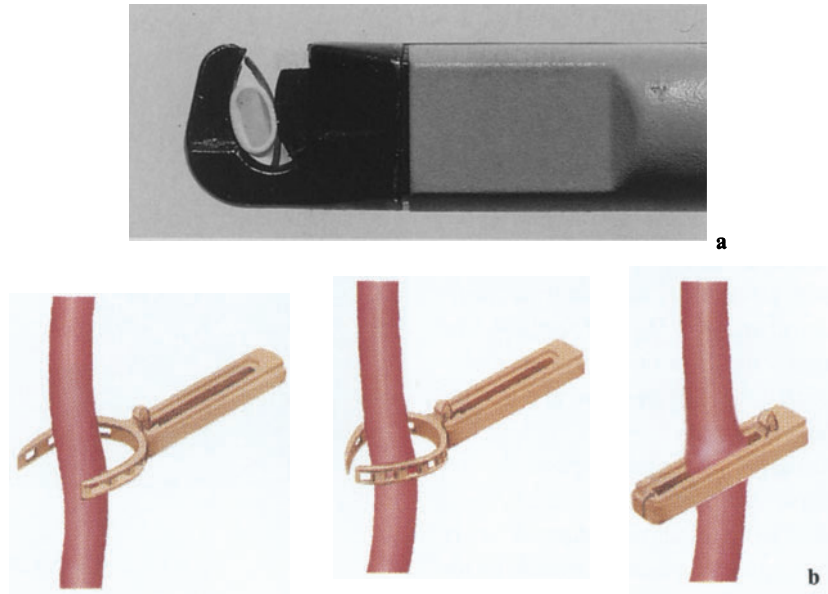

**Fig. 1.54.** **a** The rectangle hook-like orientation of the arch-shaped clips and the applicator improves control of the actual clipping process (Origin). **b** A new absorbable “lapro clip” (Davis+Geck) consists of two parts that are subsequently applied to the pedicle

### Clips for Tissue Approximation

Devices which can be used for tissue approximation by clips include the endohernia staplers of Ethicon (Cincinnati, OH, USA) and USSC. Although their efficacy in endoscopic hernia repair with mesh has been proven, the long-term effects caused by these clips to the surrounding tissue are still unclear. However, there is no comparable fast and reliable fixation system available other than these staplers. The articulating function, in particular, considerably enhances the applicability (Fig. 1.55). Their functioning principle is almost identical: the U-shaped clamp is deformed to a closed square. The only alternative is interrupted sutures, which are more reliable, but it takes considerably longer to apply single interrupted sutures than to apply a single clip.

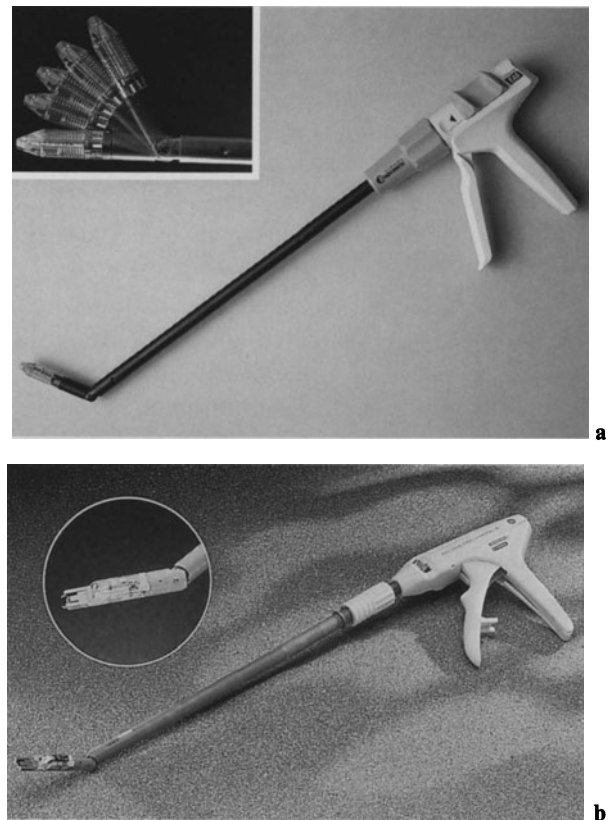

**Fig. 1.55 a, b.** The articulating function of the staplers for tissue approximation considerably enhances their applicability. Ethicon (Cincinnati, OH, USA) (**a**); USSC (**b**)

**Fig. 1.53.** **a** The Cuschieri Tayside knot. **b** The Melzer external slip knot

### \*Endo-Gastrointestinal-Anastomosis Stapler (Endo GIA \*)

Staplers have been improved and are now available in different lengths and equipped with different size clips (Fig. 1.56a). The height of the clips ranges from 2.5 to 4.8 mm. The articulating tip ( $\pm 50^\circ$ ) and the CO<sub>2</sub>-powered drive of the USSC staplers are of considerable advantage for accurate positioning end execution of the procedure. In thoracoscopic surgery the Endo GIA\* is an excellent tool for removal of small peripheral lung tumours (Fig. 1.56b).

Particular endoscopic procedures such as sigmoid resection allow the use of transanal "end-to-end anastomosis" with circular staplers. A newly developed flexible stapler has been recently introduced by the company Bieffe (Milan, Italy). Its outstanding feature is the length of approximately 100 cm. Thus the Bieffe EEA stapler seems useful for hemi-colectomies and possible for oesophageal dissection. The intra-abdominal manipulation of the stapler anvil is difficult, as is the performance of a purse-string suture. For this reason we have developed special anvil forceps and a simple purse-string technique using cable binders [85]. The binder is passed around the bowel, tightened and locked. When the tissue is firmly approximated to the stapler rod by the binder, surplus tissue is dissected and the binder's free end is cut off with scissors. To ease the introduction of the free end of the binder we have designed an open slit introducer. In future this binder may also be useful for temporary occlusion or trans-section of organs (hemi-nephrectomy) and, if absorbable, for ligation of major vessels.

### Multifunctional Instruments

Change of instruments during endoscopic surgery is time consuming and disrupts dissection considerably. Bleeding often obscures the operative field when an insulated coagulating instrument has to be inserted or clip applied. It is also the main reason for conversion to open surgery, as demonstrated by a multicentre study performed by the major European centres [48]. The solution to this problem is obtained by multifunction instruments which combine dissection, haemostasis, suction and irriga-

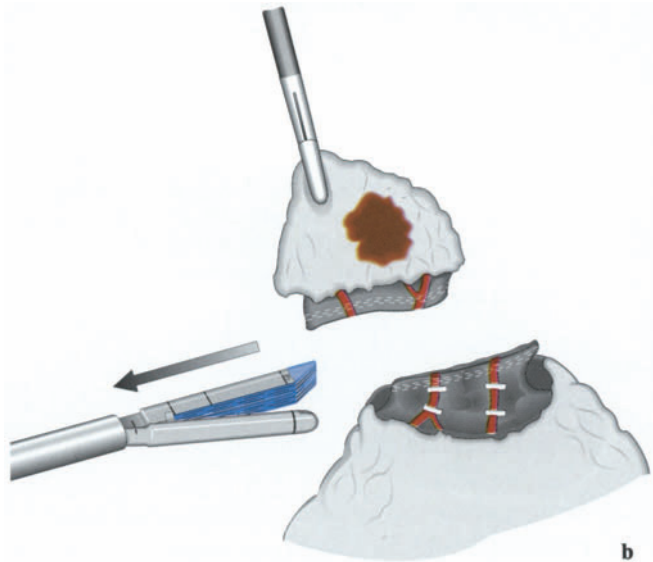
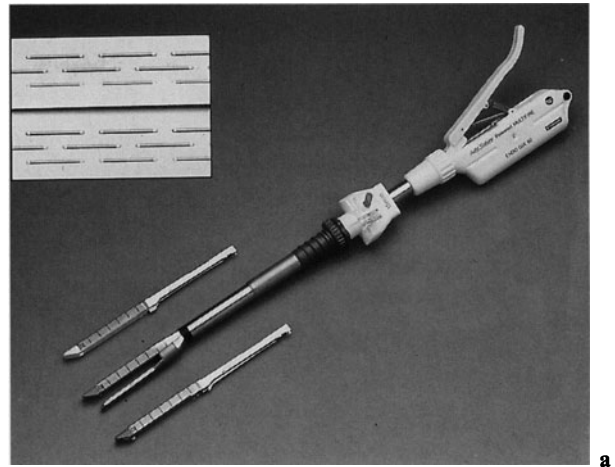

**Fig. 1.56. a** Endoscopic gastrointestinal staplers (Endo GIA\*, Ethicon and USSC) are available in different lengths (30 and 60 mm) equipped with different size clips, from 2.5 to 4.8 mm. The articulating tip ( $\pm 50^\circ$ ) and the CO<sub>2</sub> pressure drive of the USSC staplers are of considerable advantage for accurate execution of the tissue approximation. **b** The Endo GIA\* is an excellent tool for removal of small peripheral lung tumours in thoracoscopic surgery. (From: *Endoscopic Surgery Allied Technologies 1* (1993) 301, Thieme Verlag, Stuttgart) 301

tion. However, there are technological limitations in view of the restricted diameter of the access port. An example of a useful multifunctional instrument is the combination, suction-irrigation device by Wolf. It is described in Vol. 1, Chap. 2, and has been modified since. This instrument can be used for dissection, and if bleeding occurs, the function-

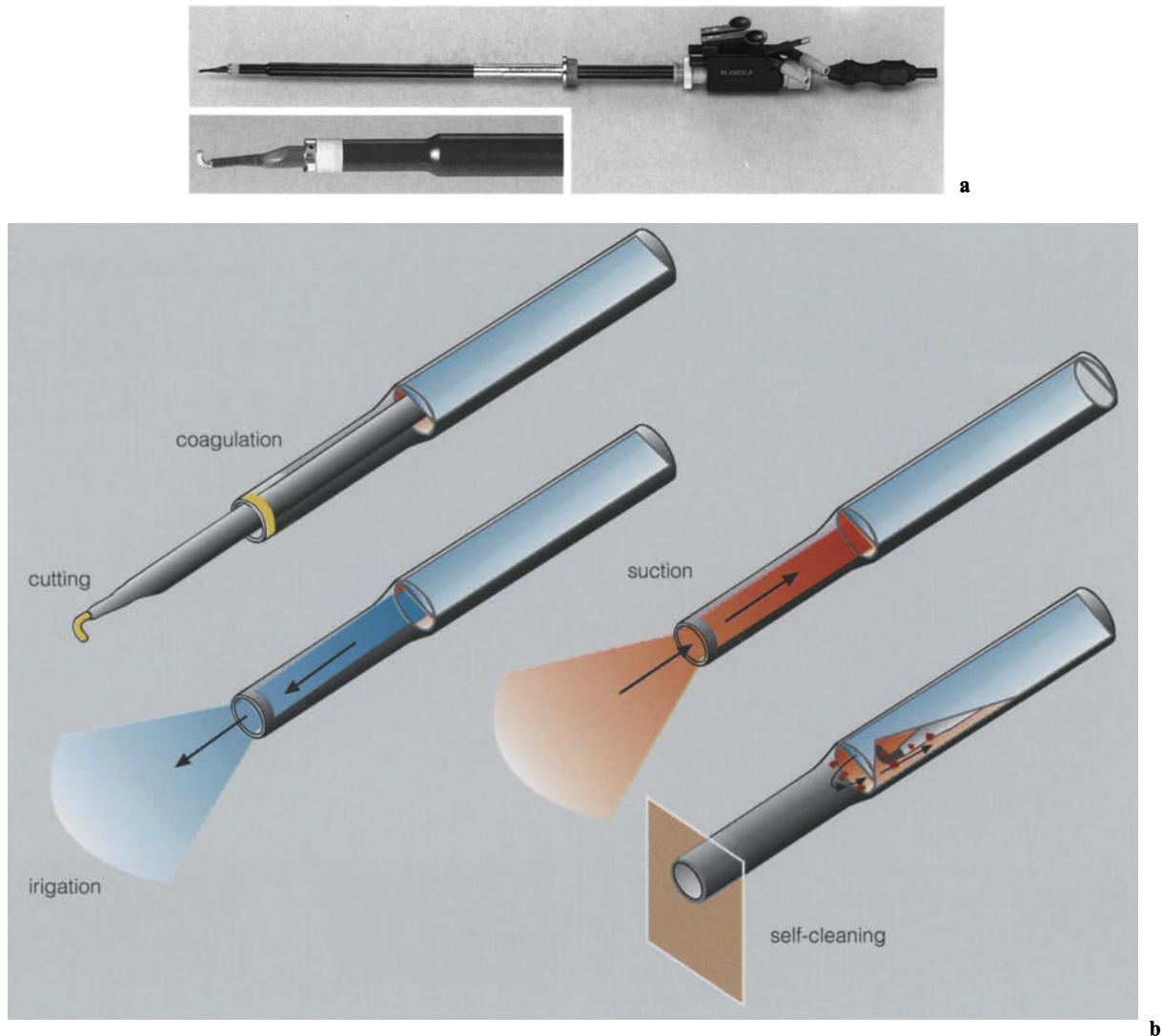

al tip of an inserted instrument is withdrawn and the channel can be used for suction and irrigation and the tip for monopolar coagulation (Fig. 1.57a, b). Other, similar instruments are available, but they are less sophisticated and partly or completely disposable. Figure 1.57c–e shows a variety of multifunctional suction probes.

A removable hook electrode (developed in Tübingen, Germany, in 1990) is incorporated with a suction probe. After withdrawing the probe, the tip allows aspiration as well as proper coagulation because the surface of the tip is enlarged. The suction channel can also be used for introduction of additional probes, including laser fibres. Retractable hooks are available from Access (Plymouth, MA,

**Fig. 1.57. a** The combination suction-irrigation device (Wolf) facilitates dissection, and in the event of bleeding partial withdrawal of the functional tip of an inserted instrument exposes the channel for suction and irrigation and the tip for monopolar coagulation. **b** Irrigation is obtained via a separate channel, thus cleaning of the main channel is possible during the operation

USA) and as a disposable item from Ethicon and Lapromed. These simple combinations are useful for regular procedures. The more exacting mobilization of bowel, stomach, uterus or prostate requires adequate multifunctional instruments.

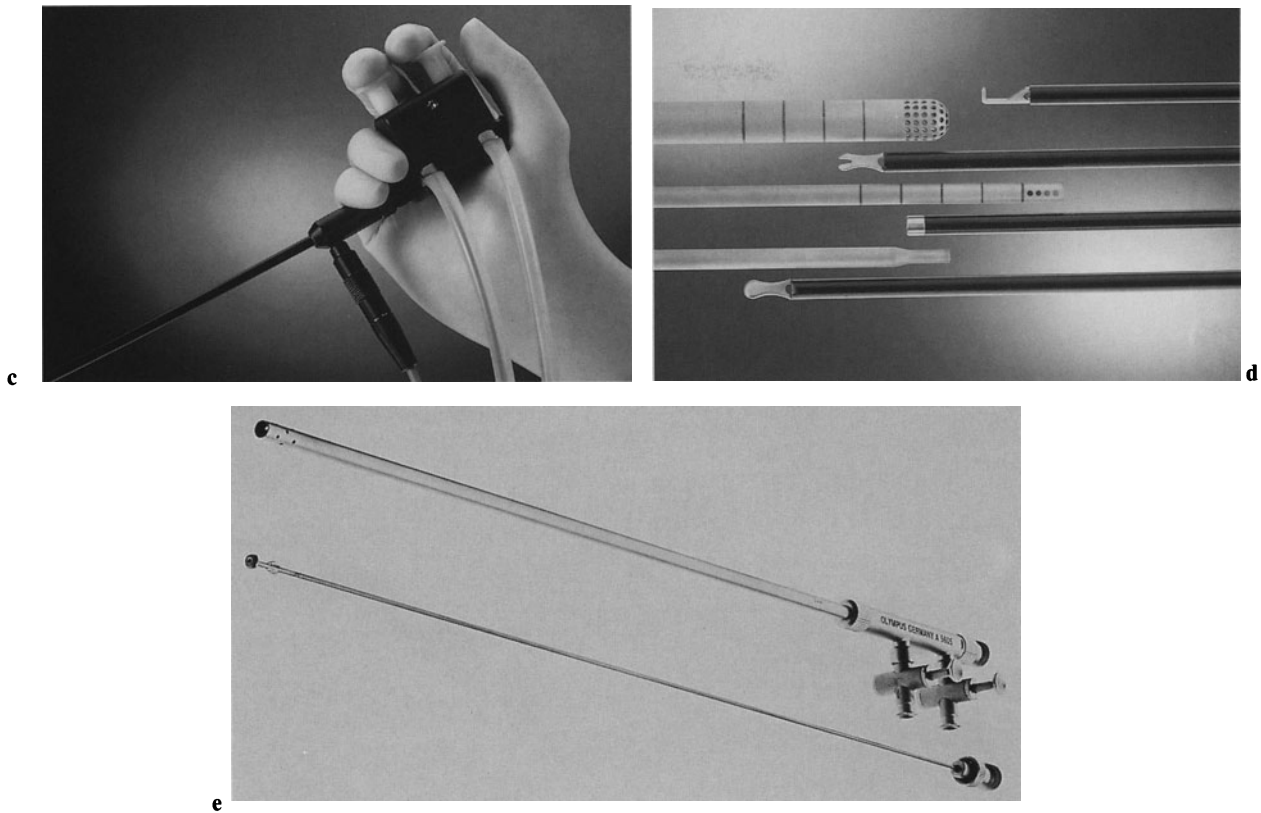

▲  
**Fig. 1.57. c–e** A variety of multifunctional suction probes (Storz (c,d), Olympus Winter&Ibe (e))

**Fig. 1.58. a,b** Retrieval bags that employ elastic opening wires facilitate gathering of the specimen (USSC, Endomedix) ▶  
 c The extraction of filled retrieval bags and gallbladders is often difficult due to the ballooning effect while pulling out the bag through the abdominal wall. **d** The “Bergetrokar” (Bühler) facilitates the extraction of specimens such as gallbladder. **e** The Dundee bag (Cameron Balloons). It is made from rib-stop nylon and shaped like a sausage. The specimen can be pulled into the bag; the free end is then drawn out of the abdomen and the contents gathered

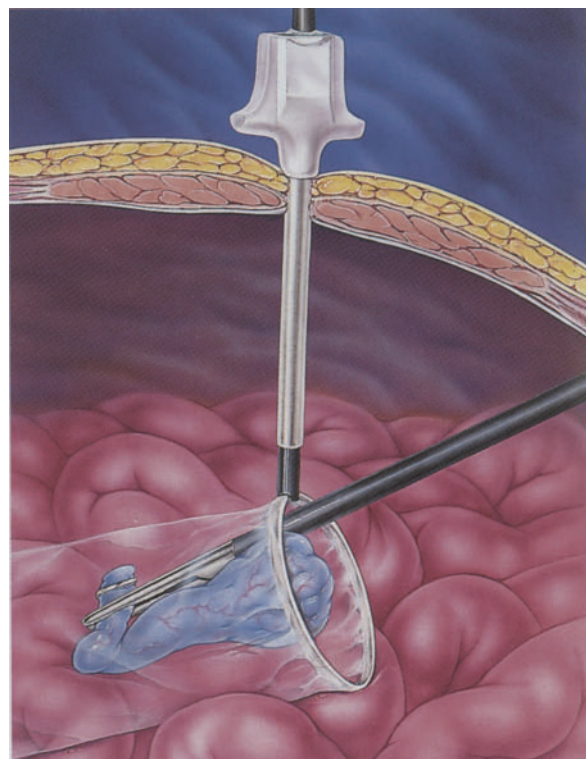
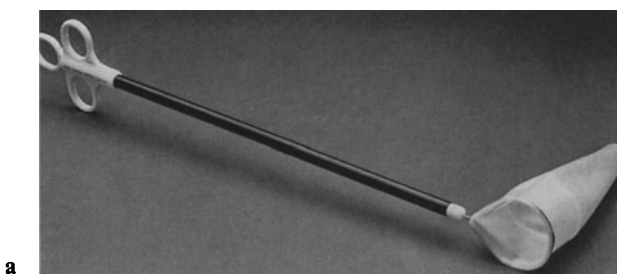

a

b



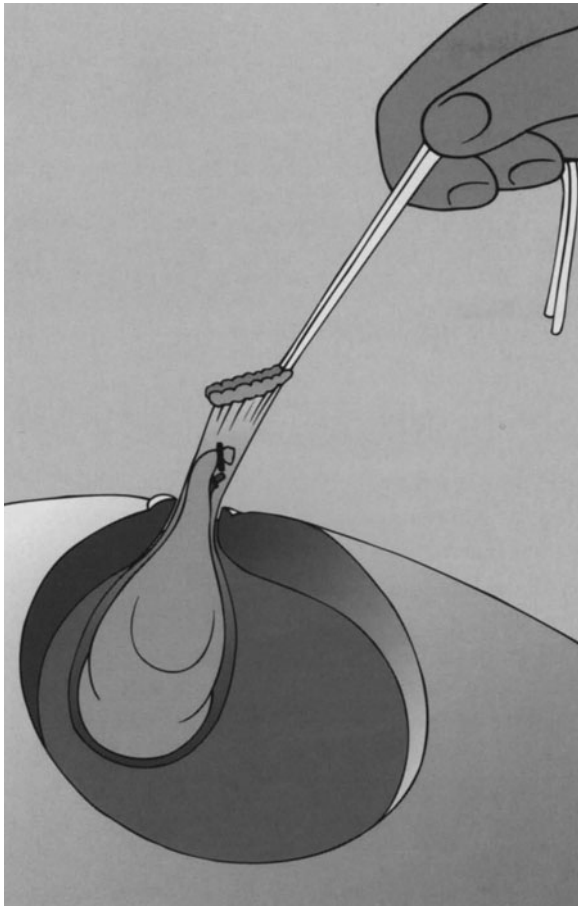

c

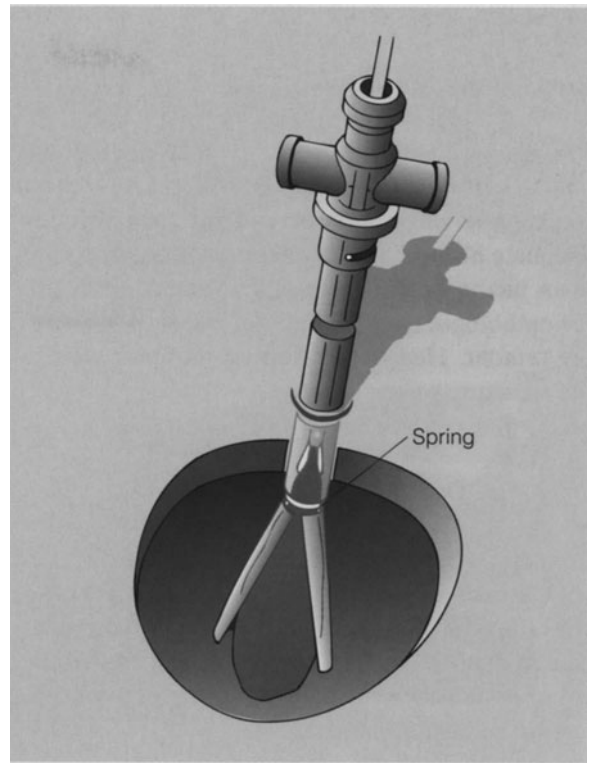

d

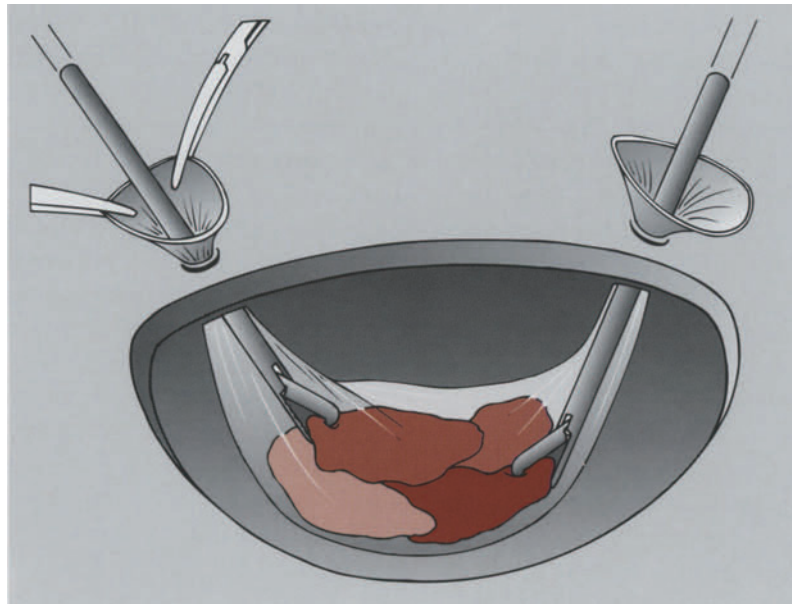

e

## Organ Extraction

### Pathological Demands

The key problem of endoscopic organ dissection is how to remove the specimen or the complete organ while preserving the structural integrity to allow adequate histopathological examination. The specimen has to be complete or transected such that the pathologist can examine and assess the organ or the tumour. Hence, transection must not destroy the structure of the organ.

### Oncologic Demands

For curative purposes the tumour must be dissected with a clear margin of intact tissue in accordance with the type of tumour. If a tumour is manipulated and removed within the body cavity, special precautions and equipment are needed to prevent spillage of malignant cells.

### Current Morcellators

Several devices have become available based on motor driven morcellation and mincing of tissue. The organ is put into an intra-abdominal bag, the morcellator inserted in the bag and the organ minced. The minced tissue cannot be subjected to reliable pathological examination. Even when the pathological preoperative assessment has indicated a benign process, the basic principle of postoperative histological examination must not be compromised. Fragmentation itself is useful in some situations, e.g. for stone removal.

### Retrieval Bags and Devices

Organ or specimen retrieval through a small incision without damaging the organ and losing the contents and without contamination of the abdominal wall is virtually impossible. To solve this problem various retrieval bags have been designed (Table 1.4).

**Table 1.4.** Important features of retrieval bags

---

Easy insertion, adequate capacity and ready unfolding within the abdominal cavity.
The opening should be as wide as possible.
The closure water tight and easy to perform.
The material must be waterproof and transparent to allow endoscopic control of the content.
The material must be as tear proof as possible and equipped with good sliding properties.
Plastic films are useful but are not as tear proof as woven materials.
The bag should be steerable by means of a guiding rod.

---

The bags marketed by Endomedix, USSC etc. have a useful opening mechanism. A superelastic wire is inserted in the opening edge of the bag. This gives the bag both guiding facility and a wide opening. However, the bag must be withdrawn for closure and sealing, which can lead to loss of content. The other bags without an opening wire (Ethicon, Cincinnati, OH, USA; Dexide; Cabot Medical, Langhorne, PA, USA) are simple and appropriate for smaller specimens such as gallbladder and appendix. As the extraction of full bags, as well as gallbladders, is often difficult due to the ballooning effect (Fig. 1.58a) when the bag is pulled through the abdominal wall, the "Bergetrokar" (Bühler) can be used (Fig. 1.58d). Although it is a massive 20-mm cannula, the two half shells of the retrieval element facilitate considerably the passage of the specimen through the insertion.

A newly designed bag from Dundee (Cameron Balloons; Bristol, UK) is made from rib-stop nylon and shaped like a sausage (Fig. 1.58e). One end can be tightened around an instrument and the other end is wide open. The specimen can be pulled into the bag and the free end is then drawn out of the abdomen through a small incision, according to the size of the specimen. In combination with a simple slicer the surgeon is able to cut the organ into slices which are suitable both for extraction through a small incision and adequate for reliable histopathological examination.

## References

1. Jakobeus (1910) Über die Möglichkeit, die Zystoskopie bei Untersuchung seröser Höhlung anzuwenden. *Münch Med Wochenschr* 57:2090–2092
2. Wittmoser R, Pfau F (1953) Technik der endoskopischen Farbenphotographie. *Photogr Wissensch* 2(2)
3. Semm K (1984) Operationslehre für endoskopische Abdominal-Chirurgie. Schattauer, Stuttgart
4. Buess G (ed) (1990) Endoskopie. Von der Diagnostik bis zur neuen Chirurgie. Deutscher Ärzte-Verlag, Cologne
5. Cuschieri A, Berci G (eds) (1990) Laparoscopic biliary surgery. Blackwell Scientific, Oxford
6. Melzer A, Buess G, Cuschieri A (1992) Instruments for endoscopic surgery. In: Cuschieri A, Buess G, Perrisat J (eds) Operative manual of endoscopic surgery. Springer, Berlin Heidelberg New York
7. Melzer A, Schurr MO, Kunert W et al (1993) Intelligent surgical instrument system ISIS. Concept and preliminary experimental application of prototypes. *Endosc Surg Allied Technol* 1:165–170
8. Becker H, Melzer A, Schurr MO, Buess G (1993) 3-D techniques in endoscopic surgery. *Endosc Surg Allied Technol* 1:40–46
9. Bouchet A (1990) Geschichte der Chirurgie vom Ende des 18. Jahrhunderts bis zur Gegenwart. In: *Illustrierte Geschichte der Medizin*, vol. 5, Andreas & Andreas, Salzburg, pp 2471–2537
10. Davis CJ (1992) A history of endoscopic surgery. *Surg Lap Endosc* 2:16–23
11. Melzer A, Buess G, Mentges B et al (1991) The developmental principles of minimal invasive surgery. 1st European conference on biomedical engineering. Nice
12. Melzer A (1993) *Medicus and Technicus* (editorial). *Endosc Surg Allied Technol* 1:63–64
13. Buess G (1993) Why this journal? (Editorial). *Endosc Surg Allied Technol* 1:1–2
14. Bertalanfy L (1974) The history and status of general systems theory. In: Couger JD, Knapp RW (eds) *System analysis and techniques*. Wiley, New York
15. Menz W, Buess G (1993) Potential applications of microsystem engineering in minimal invasive surgery. *Endosc Surg Allied Technol* 1:171–180
16. Omata S, Terunuma Y (1991) Development of new tactile sensors for detecting hardness and/or softness on an object like the human hand. *Transducer's 91*, San Francisco
17. Perez CA, Weed HR (1991) Optimization of the relationship between pulse width, pulse frequency and sensation thresholds for vibrotactile information transfer. *Annu Int Conf IEEE* 13(4)
18. Melzer A (1993) Quality standards of the reliability and applicability of instruments for endoscopic surgery. 1st European congress on endoscopic surgery, Cologne
19. Arbeitskreis für Krankenhaushygiene (1992) Infektionsprophylaxe in der endoskopischen Chirurgie. *Hyg Med* 17:378–380
20. Hingst J, Steinmann N (1993) Infectiological aspects. International Hospital Hygiene Association, 2nd meeting, Heidelberg
21. Bornef J (1982) *Hygiene*. Thieme, Stuttgart, pp 435–445
22. Janssen DW, Schneider PM (1993) Overview of ethylene oxide alternative sterilization technologies. *Zentralbl Steril* 1:16–32
23. Jacobs P, Kowatsch R (1993) Sterrad sterilization system: a new technology for instrument sterilization. *Endosc Surg Allied Technol* 1:57–58
24. Jewett DJ, Heinson P, Bennet C et al (1992) Blood-containing aerosols generated by surgical techniques: a possible infectious hazard. *Am Ind Hyg Assoc* 53:228–231
25. Association of Operating Room Standards and Recommended Practises for Perioperative Nursing (1987) *Recommended practices for sterilization and disinfection*. AORN 45:440
26. Committee on Infection Control in the Handling of Endoscopic Equipment (1980) Guidelines for preparation of laparoscopic instrumentation. *AORN* 32:65
27. Marshburn PB, Rutala WA, Wannamaker NS, Hulka JF (1991) Gas and steam sterilization of assembled versus disassembled laparoscopic equipment. *Microbiologic studies*. *Reprod Med* 36:483–487
28. Ebel B (1990) Biokompatibilität von Implantatwerkstoffen. Bericht 4776. Kernforschungszentrum, Karlsruhe, Germany
29. Wamsteker K (1989) Documentation in laparoscopic surgery. *Baillieres Clin Obstet Gynaecol* 3(3):625–647
30. Cuschieri A, Berci G (eds) (1990) Laparoscopic cholangiography. In: Cuschieri A, Berci G (eds) *Laparoscopic biliary surgery*. Blackwell Scientific, Oxford, pp 116–131
31. Greeg RD (1988) The case for selective cholangiography. *Am J Surg* 155:540–544
32. Pasquale MD, Nauta RJ (1989) Selective versus routine use of intraoperative cholangiography. *Arch Surg* 124:1041–1042
33. Operating manual for C-Arm series 9400 (1992) OEC diasonics, 384 Wright Brothers Drive, Salt Lake City, Utah 84116, USA
34. Miles WFA, Paterson-Brown S, Garden OJ (1992) Laparoscopic contact hepatic ultrasonography. *Br J Surg* 79:419–420
35. Ohta Y, Fujiwara K, Sato Y, Niwa H, Oka H (1983) New ultrasound laparoscope for diagnostic of intra-abdominal diseases. *Gastrointest Endosc* 29:289–294
36. Weir J, Abrahams PH (1992) *An Imaging atlas of human anatomy*. Wolfe, London
37. Loughlin KR, Brooks DC (1992) The use of a doppler probe to facilitate laparoscopic varicocele ligation. *Obstet Gynecol* 174:326–328
38. Loughlin KR, Brooks DC (1992) The use of a Doppler Probe in Laparoscopic Surgery. *Lap Endosc Surg* 2:191–194
39. Lange T (1993) State of the art of video techniques for endoscopic surgery. *Endosc Surg Allied Technol* 1:29–35
40. Zobel J (1993) Basics of three-dimensional endoscopic vision. *Endosc Surg Allied Technol* 1:36–39
41. Lattwein G, Kremer RW (1990) Photo-, Film- und Videodokumentation mit dem starren Endoskop. In: Buess G (ed) *Endoskopie. Von der Diagnostik zur neuen Chirurgie*. Arztverlag, Cologne, pp 208–216

42. Semm K (1992) Intrafasziale Hysterektomie. WISAP, Sauerlach, Germany, p 112
43. Ott D (1991) Laparoscopic hypothermia. *J Surg* 1: 183–186
44. Ison KT, Matuszewski M, Copcoat MJ (1993) Intraperitoneal temperature monitoring in laparoscopy. Society for Minimally Invasive Therapy, 5th international meeting, Orlando
45. Morin C, Berta C, Rene A (1993) Modification of the body temperature during the operative laparoscopy. Society for Minimally Invasive Therapy, 5th international meeting, Orlando
46. Ott DE (1991) Correction of laparoscopic insufflation hypothermia. *J Lap Surg* 1:183–186
47. Laparoscopic insufflators. *Health Devices* 21:183
48. Cuschieri A, Dubois F, Mouiel J, Mouret P, Becker H, Buess G, Trede M, Troidl H (1991) The European experience with laparoscopic cholecystectomy. *Am J Surg* 161:385–387
49. Farin G (1992) Principles of high-frequency surgery. Erbe Elektromedizin, Tübingen
50. Mecke H (1992) Intraabdominale Verwachsungslösung. Hippokrates, Stuttgart
51. Reidenbach H-D, Theiss R, Holder KW (1986) Experimentelle Studie zur flüssigkeitsunterstützten bipolaren Hochfrequentotomie parenchymatöser Organe. *Biomed Tech (Berlin)* 31:66–67
52. Farin G (1994) Argon Gas Coagulation. *Endosc Surg Allied Technol* 2:71–77
53. Grund KE, Storek D, Farin G (1994) Endoscopic argon-gas-coagulation. First clinical experiences. *Endosc Surg Allied Technol* 2:42–46
54. Rusch VW, Schmidt R, Shoji Y, Fujimura Y (1990) Use of the argon beam electrocoagulator for performing pulmonary wedge resection. *Soc Thorac Surg* 49: 287–291
55. Dunham CM, Cornwell EE, Mitello P (1991) The role of the argon beam coagulator in splenic salvage. *Surg Gynecol Obstet* 173:179–181
56. Farin G (1993) Pneumatically controlled bipolar cutting instrument. *Endosc Surg Allied Technol* 1:97–101
57. Storch BH, Rutgers EJ, Gortzak E, Zoetmueller PA (1991) The impact of CUSA ultrasonic dissection device on major liver resection. *Neth J Surg* 43:99–101
58. Putnam CHW (1983) Techniques of ultrasonic dissection in resection of the liver. *Surg Gynecol Obstet* 157:47
59. Amaral JF, Chrostek (1993) 5 mm Ultrasonically activated scalpel. Society for Minimally Invasive Therapy, 5th international meeting, Orlando
60. Cuschieri A, Berci G (1990) Laparoscopic treatment of common duct stones. In: Cuschieri A, Berci G (eds) *Laparoscopic biliary surgery*. Blackwell Scientific, Oxford, pp 155–169
61. Mentges B, Buess G, Melzer A, Schäfer D, Becker HD (1991) Results of laparoscopic cholecystectomy. In: Mosby year book on lithotripsy and related techniques for gallstone treatment. Mosby, St Louis, pp 183–190
62. Nathanson L, Shimi S, Cuschieri A (1991) Laparoscopic cholecystectomy: the Dundee technique. *Br J Surg* 78:155–159
63. Cuschieri A (1991) Minimal access surgery and the future of interventional laparoscopy. *Am J Surg* 161:104–407
64. Berci G, Sackier JM, Paz-Parlow M (1991) New ideas and improved instrumentation for laparoscopic cholecystectomy. *Surg Endosc* 5:1–3
65. Schaller G, Manegold BC, Künkel M (1992) Optical access to the abdominal cavity. Video, World congress on endoscopic surgery, Bordeaux
66. Klemm B, Salm R, Wanninger J (1993) More safety in the access to the abdominal cavity by looking through the peritoneum at the structures behind it. Society for Minimally Invasive Therapy, 5th international meeting, Orlando
67. Melzer A, Weiss U, Roth K, Loeffler M, Buess G (1993) Visually controlled trocar insertion by means of the “optical scalpel”. *Endosc Surg Allied Technol* 1:239–242
68. Oshinsky GS, Smith AD (1992) Laparoscopic needles and trocars: an overview of design and complications. *J Lap Surg* 2:117–125
69. Netzhat FR, Silfen SL, Evans D, Netzhat C (1991) Comparison of direct insertion of disposable and standard reusable laparoscopic trocars and previous pneumoperitoneum with Veress needle. *Obstet Genecol* 78:148–149
70. Hasson HM (1971) Modified instrument and method for laparoscopy. *Am J Obstet Gynaecol* 110:886–887
71. Reich H, McGlynn (1990) Short self-retaining trocar sleeves for laparoscopic surgery. *Am J Obstet Gynaecol* 162:453–454
72. Loeffler M, Trispel S (1993) Technological principles of curved instruments and flexible cannulae. *Endosc Surg Allied Technol* 1:365–370
73. Cuschieri A, Shimi S, Banting S, Van Velpen G, Dunkley P (1993) Coaxial Curved Instrumentation for Minimal Access Surgery. *Endosc Surg Allied Technol* 1:303–305
74. Périssat J (1992) Laparoscopic cholecystectomy. In: Cuschieri A, Buess G, Périssat J (eds) *Operative manual of endoscopic surgery*. Springer, Berlin Heidelberg New York, pp 209–232
75. Cuschieri A (1991) Variable curvature shape-memory spatula for laparoscopic surgery. *Surg Endosc* 5:179–171
76. Stöckel D, Melzer A (1993) New developments in superelastic instrumentation for minimally invasive surgery, medical data meeting. American College of Surgeons, San Francisco
77. Duerig T, Melton K, Cayman M, Stöckel D (eds) (1990) *Engineering aspects of shape memory alloy*. Butterworth-Heinemann, London
78. Lirici MM, Melzer A, Reuthebuch O, Buess G (1993) Experimental development in colorectal surgery. *Endosc Surg Allied Technol* 1:20–25
79. Schurr MO, Melzer A, Dautzenberg P, Neisius B, Trapp R, Buess G (1993) Development of steerable instruments for minimal invasive surgery in modular conception. *Acta Chir Belg*
80. Melzer A, Schurr MO, Kunert W, Buess G et al (1993) Intelligent surgical instrument system. Concept and preliminary experimental application of components and prototypes. *Endosc Surg Allied Technol* 1:165–170

- 
81. Köhler GW (1981) Typenbuch der Manipulatoren. Thiemig, Stuttgart
  82. Szabo Z (1994) Analysis of movements during endoscopic suturing. *Endosc Surg Allied Technol* 2:55–61
  83. Melzer A, Schurr MO, Lirici MM, Klemm B, Stöckel D, Buess G (1994) Future trends in endoscopic suturing. *Endosc Surg Allied Technol* 2:78–82
  84. Andrews SM, Lewis JL (1994) Laparoscopic knot substitutes. *Endosc Surg Allied Technol* 2:62–65
  85. Lirici MM, Buess G, Melzer A, Weinreich S, Becker HD (1993) Experimental results of colon resection with the Tübingen procedure. *Br J Surg* (in press)