

Y3.N 215:6/748

National Advisory Committee

for Aeronautics

MAILED

JAN 30 1940

So Library, *Hartford Public*

N 748

GOVT. DOC.

TECHNICAL NOTES

NATIONAL ADVISORY COMMITTEE FOR AERONAUTICS

No. 748

PRINCIPLES, PRACTICE, AND PROGRESS OF

NOISE REDUCTION IN AIRPLANES

By Albert London
National Bureau of Standards

Washington
January 1940

BUSINESS, SCIENCE
& TECHNOLOGY DEPT.

CONTENTS

	Page
I. Introduction	1
II. The Nature of Sound and Hearing	1
III. Sources of Noise in Aircraft	14
A. Propeller Noise	15
B. Exhaust and Engine Noise	19
C. Aerodynamic and Ventilating Noise	21
D. Secondary Noise Sources	24
IV. Soundproofing the Airplane	26
A. The Noise-Reduction Factor	26
B. Sound Absorption	31
C. Sound Insulation	39
D. Soundproofing Procedures	46
Bibliography	53

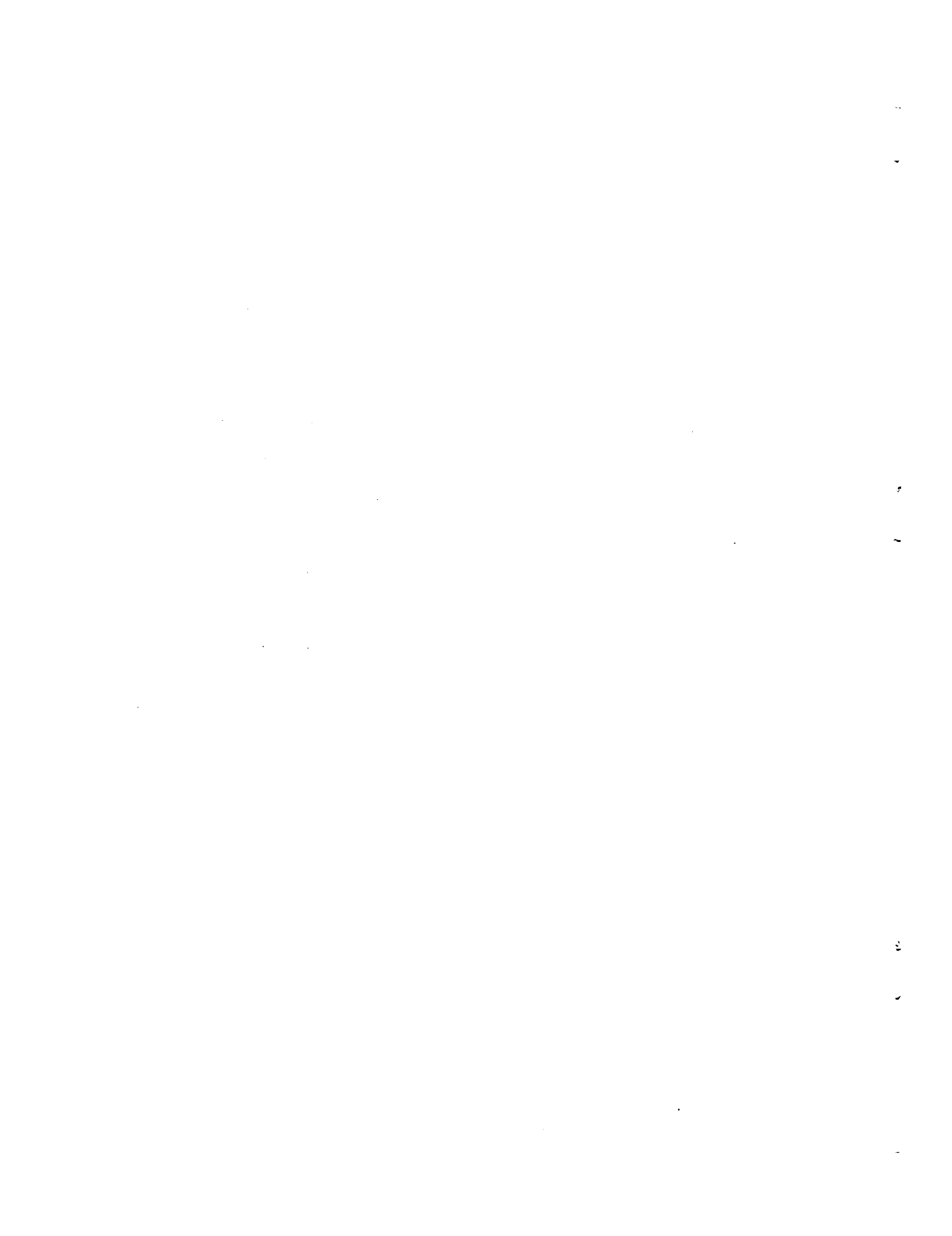

NATIONAL ADVISORY COMMITTEE FOR AERONAUTICS

TECHNICAL NOTE NO. 748

PRINCIPLES, PRACTICE, AND PROGRESS OF
NOISE REDUCTION IN AIRPLANES

By Albert London

I. INTRODUCTION

A decade ago, the air traveler's only protection against the deafening din of noise was the cotton plug which he could insert in his ear. Nothing speaks more eloquently for the progress which has been achieved in quieting the airplane than the fact that in night travel on certain air lines, passengers must be cautioned to speak quietly in order that those asleep be not disturbed.

This transition from "cotton plug" to "Quiet, please," has only been possible of attainment by a full application of the principles of acoustics. The investigators in this field have had to consider many and diverse topics. To name a few: What are the principal sources of noise in the airplane, and how may they be reduced or eliminated? How may we measure noise? What is the relationship between the purely physical attributes of noise and the physiological reaction of the ear to this stimulus? How may the filtration of noise into the airplane cabin be reduced by proper attention to constructional details, and how can this be accomplished with a minimum of weight? What systematic procedure should be used in carrying out this quieting process?

It is the purpose of this paper to review the body of knowledge which has been accumulated in this field. Special attention will be paid to effective soundproofing schemes, and all the data available in the published literature on this subject will be given.

II. THE NATURE OF SOUND AND HEARING

Most of us are familiar with the fact that whenever we hear a sound, we usually find that the source is a vi-

brating body of some kind. When the body is set in motion, the layer of air next to it takes on an exactly similar motion. This disturbance is then handed on from one layer of air particles to the next, until it ultimately reaches the ear.

An exactly similar process occurs when a stone is thrown into water. Here, there is visual evidence of a wave traveling outward from the center of the splash. However, to make our analogy agree more closely with what is actually happening in a sound wave, we should have to contrive, in some way, to have a number of crests emitted from the center of the disturbance periodically. Perhaps we might have a large number of stones and drop them in the water at the rate of, say, one a second. Then, every second a new crest would travel outward and the wave could be said to have a "frequency" of one crest per second. The distance between two adjacent crests is known as the wave length and, evidently, in this case it is equal to the distance the wave travels in one second. In general, for any wave motion, the following relation is true:

$$\text{Velocity of wave motion} = \text{frequency} \times \text{wave length}$$

In the simple sound source, the tuning fork, an analogous phenomenon takes place. Here the vibration of the prongs of the fork causes a wave motion in the air which is perceived as a sound by the ear. The frequency of the sound wave is equal to the number of vibrations which the prongs of the fork make per second, and is said to be so many cycles per second. If the fork vibrates a large number of times per second, we say its pitch is high; if only a few, its pitch is low. Thus, the highest note a standard piano produces is about 4,600 cycles per second, whereas, the lowest is about 30 cycles per second.

The tuning fork is a simple source of sound, only one frequency corresponding to its motion. There exist more complex sources, in which several frequencies are present. Thus, if two keys on a piano be struck, the air particles must vibrate as a result of both frequencies. Imagine how complex must be the dance of the air particles under the influence of a symphony orchestra where numerous frequencies from 30 to 10,000 cycles per second are present. In the more complex sound sources three types of frequency distributions are evident: 1) The frequency spectrum has only a discrete number of frequencies present; 2) a continuous distribution of frequencies is present; 3) a combination of 1) and 2) consisting of both a continuous and

a discrete frequency spectrum. Noise usually contains a large number of frequencies, having a spectrum which may fall under any one of these three classes.

There are many ways in which the investigator may analyze different sounds to find the constituent frequencies. Most of the methods in general use operate on a selective tuning principle, in which the instrument response is a maximum at one definite frequency. To cover a wide range of notes, the frequency of maximum response is made variable in a prescribed fashion so that the frequencies present in the analyzed sound may be readily determined from the setting of the instrument. For example, one commercial form of this type of device, the wave analyzer, has as its essential element a crystal which will respond to one frequency only, say 50,000 cycles per second. If a sound wave of 10,000 cycles per second is picked up by a microphone, and the electrical current so generated is amplified, and then passed through the analyzer, it is possible to get a response only by somehow stepping up the 10,000-cycle note to 50,000. To do this, the instrument is provided with an oscillator which can generate a wave of any frequency desired. By the well-known heterodyne effect, if a frequency of 40,000 cycles per second be combined with a frequency of 10,000 cycles per second in the proper way, we get as a result, the sum and difference of the two frequencies, i.e., 30,000 and 50,000 cycles per second. The 30,000 note may be suppressed and the 50,000 note passed through the crystal filter. The dial, which controls the frequency of the local oscillator, may be calibrated to read 10,000 cycles per second directly.

There is another type of analyzer commonly in use, in which an electrical circuit is used which will pass a given band of frequencies only. For example, it may pass all the frequencies in the octave between 512 and 1,024 cycles per second and reject all others. This type of device is known as a band-pass filter. By having a number of these band-pass filters, a frequency analysis to cover any desired range may be obtained.

Any sound, in addition to having some definite frequency spectrum associated with it, possesses one other important physical attribute, namely, intensity. To return to our tuning fork, if the prongs be tapped harder, more energy will be imparted to the vibrational motion, and the excursions of the prong from its rest position will be larger. It can be readily shown that the energy

associated with the motion of the fork is proportional to the square of its amplitude (the maximum displacement from the equilibrium position). A larger amplitude is imparted to the air particles, which, since they have a motion similar to that of the fork, therefore have an energy also proportional to the square of their amplitude. The maximum velocity of the air particles and the maximum pressure built up in the sound wave may both be shown to be proportional to the amplitude, so that the energy in a sound wave depends on the square of the particle velocity or of the pressure of the wave. By the term "intensity," we mean the total amount of sound energy which flows through unit area normal to the direction of propagation of the wave in one second. The units of intensity are, therefore, watts per square centimeter. However, to express sound intensities or energies, almost exclusive use is made of the decibel scale.

The decibel scale first came into use in telephony and electrical communications work, where it was desired to have a convenient way to express the ratio of two different values of such electrical quantities as current, voltage, or power. The decibel difference between two powers, P_1 and P_2 , is defined as $10 \log_{10} \left(\frac{P_1}{P_2} \right)$. Since the power developed in a resistance R_1 , by a current I_1 , is $P_1 = I_1^2 R_1$, or by a voltage V_1 is $P_1 = \frac{V_1^2}{R_1}$, we have:

$$\begin{aligned} \text{Decibel difference between } P_1 \text{ and } P_2 &= \\ &= 10 \log_{10} \left(\frac{P_1}{P_2} \right) = 10 \log_{10} \left(\frac{I_1^2 R_1}{I_2^2 R_2} \right) = 10 \log_{10} \left(\frac{V_1^2 R_2}{V_2^2 R_1} \right) \quad (1) \end{aligned}$$

If R_1 happens to be equal to R_2 , we have:

$$\begin{aligned} \text{Decibel difference} &= 10 \log_{10} \left(\frac{I_1}{I_2} \right)^2 = 10 \log_{10} \left(\frac{V_1}{V_2} \right)^2 \\ &= 20 \log_{10} \left(\frac{I_1}{I_2} \right) = 20 \log_{10} \left(\frac{V_1}{V_2} \right) \quad (2) \end{aligned}$$

Thus, in sound measurements, the decibel difference between two sounds is given by $10 \log_{10} \frac{E_1}{E_2}$ where E_1 and E_2

are the energies of the respective waves. Since the energy in a sound wave is proportional to the square of the sound pressure or particle velocity, we have:

$$10 \log_{10} \frac{E_1}{E_2} = 20 \log_{10} \frac{P_1}{P_2} = 20 \log \frac{V_1}{V_2} \quad (3)$$

where p and v represent sound pressure and particle velocity.

The decibel scale has several advantages which, however, we can more intelligently discuss after we have considered some of the phenomena associated with hearing.

The ear is a remarkably sensitive mechanism. At the lower limit of audibility (for the frequency of maximum sensitivity) it is possible for the ear to detect a motion of air particles which have an amplitude of only one-billionth of a centimeter (10^{-9} cm). If one remembers that molecular dimensions are of the order of magnitude of 10 times as much, i.e., 10^{-8} centimeter, it becomes evident how extraordinarily sensitive the ear is. On the other hand, at the upper limit (for this same frequency of maximum sensitivity), sounds about one million million times as intense can be heard. The ear has a range therefore of about 10^{12} in energy. In decibels this range can be expressed as $10 \log_{10} 10^{12}$, which is 120 decibels. That is, the sound level at the upper limit of audibility is 120 decibels above the sound level at the threshold of audibility. The decibel scale is, therefore, a compressed scale telescoping a ratio of 1 to 10^{12} in energy into 0 to 120 decibels.

Since a sound level in decibels really states how much more intense one sound is as compared with another, it is always necessary to know what the intensity of the reference sound is. The standard reference level has been defined by the American Standards Association as the intensity of 10^{-16} watts per square centimeter. This corresponds to a root-mean-square pressure of 0.0002 dynes per square centimeter in a plane progressive sound wave.*

*Other reference levels have been in use prior to the adoption of this standard. One common level in use, especially in airplane noise measurements, has been the intensity of a wave having a root-mean-square pressure of 0.001 dyne per square centimeter (1 millibar). Readings in decibels with this latter reference level are 13.8 db lower than those referred to the standard reference level. In this paper all levels, unless otherwise stated, are referred to 10^{-16} watts per sq. cm.

With this as a reference level, figure 1 gives some idea of the relation between the decibel scale and the sensation perceived by the ear.

Of more immediate interest for our purpose, is the range of levels found in moving vehicles. Table I,* which has been adapted from Zand (reference 32), gives the levels to be found in different types of transportation plus the associated subjective measure of the degree of comfort experienced.

The decibel scale is strictly a physical scale for intensity measurements. However, of primary interest is the sensation which is perceived by the ear as a result of the physical stimulus. The psychological reaction of the individual varies from person to person, so that in order to formulate the relationship existing between the physical stimulus and psychological sensation, it is necessary to investigate a large number of ears before any conclusions may be ascertained about the average ear.

It is found in this way that the sensation is a rather complex function of the intensity and frequency. For example, it was desired to ascertain when two different notes sounded equally loud to an observer. To do this, sounds of two frequencies were compared. One had a frequency of 1,000 cycles per second, and the observer was allowed to change the intensity of the other frequency until both notes were equally loud. Proceeding in this manner, a large number of different tones could be matched in loudness to the standard reference tone of 1,000 cycles. Figure 2, which is the result of the work of Fletcher and Munson (reference 2), gives the result of such measurements.

These curves have the following meaning: If we select one of the contours, say that numbered 50, then all points on it represent notes which are equally loud. Thus, a 100-cycle note of 67-decibel intensity level, sounds as loud as a 1,000-cycle note of 50-decibel intensity, or a 7,000-cycle note of about 60-decibel intensity. The lowest curve is the threshold of hearing. It gives the intensity level at which the average normal ear can just hear, at all the frequencies from about 25 to 15,000 cycles per second. The uppermost curve is the upper limit to hearing, the so-called "threshold of feeling." Phenomenologically, it is found that with sounds of this intensity, the sound is not only heard but there is also an

*At end of report.

additional sensation of "feeling." The actual sensation varies with frequency. At the lower frequencies a feeling of vibration is experienced, while at the higher frequencies, the feeling is one of pain. Thus, the area included between the two extreme contours gives the region over which audition is possible.

The intensity level of zero decibels is set to coincide approximately with the threshold of hearing at 1,000 cycles. It will be noticed, however, that the ear is most sensitive at about 3,500 cycles. The numbers on the contours are numerically equal to the intensity level of the 1,000-cycle note to which all notes on this contour are equated in loudness, and are known as loudness levels. Since a loudness level is not a strictly physical quantity, but rather a measure of the sensation recorded by the ear, it becomes inappropriate to use the decibel as the unit of loudness level. For this usage, the term "phon" has been accepted. However, it will be found in the literature that decibels are still sometimes used interchangeably with phons. For example, if a sound has a loudness level of 70 phons, it is equal in loudness to a 1,000-cycle note of 70-decibel intensity. Hence the loudness level is said to be 70 decibels.

There are several other important features about the contours which should be pointed out. From about 500 cycles and up, the contours are approximately equally displaced from one another, a 10-decibel increase in intensity corresponding to a 10-phon increase in loudness level. This is not so for the lower frequencies, as the curves crowd together at the lower end. Thus, a small drop in intensity means a much larger drop in loudness. For example, if we have a 100-cycle tone with a level of 100 decibels, and we drop the level by 62 decibels, the sound just becomes inaudible, whereas a 62-decibel drop in a 1,000-cycle note would still be plainly audible, having a loudness level of 38 phons.

This phenomenon has fortunate consequences in the sound insulation of airplane cabins. The largest contribution to airplane noise is made by the low frequencies; furthermore, the low frequencies are the most difficult to reduce in intensity. Thus, the ear comes to the rescue, inasmuch as it willingly accepts a much lower energy diminution in the low frequencies than it will in the higher frequencies. We shall refer again to this point when we discuss sound insulation.

The loudness level contours may be plotted in a different way with frequency as the parameter. Such a representation is figure 3 (reference 2). These curves give the loudness level versus the intensity level, each curve being valid for the frequency given on the curve. It will be noted that for a large range of frequencies, from about 300 to 4,000 cycles per second, the loudness level is approximately proportional to the intensity level, and furthermore, they are both very roughly equal to each other to within ordinary engineering accuracy. At the lower frequencies, the proportionality between loudness level and intensity level is true only for a limited range of loudness levels.

The question which arises next, is that of measuring these twin quantities, decibels and phons. Just what instrumental means are available for a quantitative specification of the amount of noise present? To answer this purpose, there has appeared in recent years the sound level meter.

This device consists essentially of a microphone with an associate electrical circuit containing an amplifier, attenuator, and meter. The latter is calibrated to read decibels directly and usually covers a range of about 15 decibels. Intensities over a range from about 30 to 130 decibels may be measured by adjusting the attenuator dials.

In designing this type of instrument, particular attention is paid to what is called the response frequency characteristic, i.e., the response of the meter to different frequencies. For measuring intensity levels, it is essential that sounds of different frequencies but of the same intensity, should give the same reading. If the meter has this property, it has a "flat" frequency response. In the case where the characteristic is not flat, a noise measurement will emphasize certain frequencies at the expense of others.

However, this is exactly what is desired in measuring loudness levels. Since the ear discriminates against some frequencies, the meter should do likewise in order to measure the ear's sensation. An attempt is therefore made to incorporate in sound-level meters a response-frequency characteristic similar to that of the ear. Three different characteristics are usually provided - a flat response and two which simulate the ear's at 70 and 40 phons. Figure 4 gives the design objective which has been set for

these meters by the American Standards Association. The curves as drawn here are directly comparable to the contours of figure 2 for the loudness levels of 70 and 40 phons.* To be more specific, the 70-decibel network curve gives the intensity level of tones of different frequencies which would give the same reading on the meter as a 1,000-cycle tone. For example, a tone of 60 cycles is discriminated against to the extent of 10 decibels on the 70-decibel network, and 26 decibels on the 40-decibel network; if it has an intensity of 75 decibels, it will read 65 decibels on the 70-decibel network and 49 decibels on the 40-decibel network. To get these three different characteristics, specially designed electrical circuits are provided. At the flip of a switch, any of these three networks may be introduced. It is recognized that the incorporation of only three networks is a compromise necessitated by the difficulty and expense of simulating the ear's response at all loudness levels. For this reason the meter performance is only an approximation to what the ear hears. In addition, there are certain tolerances permitted in designing the networks, so that very often the frequency response of the instrument is such that errors are introduced in the measurements. The sound-level meter, before being put into use, should always be calibrated so as to determine the extent of agreement with the design objective. With reference to the use of the various networks in the sound-level meter, the "A.I.E.E. Test Code for Apparatus Noise Measurement" recommends that the 40-decibel network "be used for usual apparatus noise measurements," the flat network "for very high intensities where low frequency noise is predominant" and that the 70-decibel network "be used only in special cases."

It should be mentioned that Davis (reference 1) has recently stated that the American sound-level meter does not give the correct value for the equivalent loudness of a noise consisting of a series of impulses or having considerable intermittency, the reading being too low. In accordance with his findings, Davis has constructed a meter which gives results in agreement with aural observations on this type of noise.

*There are certain inherent differences between the ear and a microphone as a sound-measuring device. Hence, the curves of figure 4 are necessarily slightly different from those of figure 2. These corrections are introduced to take care of the difference between the conditions under which the ear response was obtained as compared to the conditions under which noise measurements are usually taken.

In many noise measurements, there frequently occurs the case in which there are several component frequencies, one of which is predominantly loud. The reading obtained will be practically the same as if the quieter tones were missing. Consider a simple numerical example; there are two sound sources - one emits a note of intensity 80 decibels, the other 60 decibels.

$$R_1 = 80 \text{ db} = 10 \log_{10} \frac{E_1}{E_0} \quad \text{or} \quad E_1 = 10^8 E_0$$

$$R_2 = 60 \text{ db} = 10 \log_{10} \frac{E_2}{E_0} \quad \text{or} \quad E_2 = 10^6 E_0$$

Corresponding to the reading of 80 decibels, the energy E_1 is 100 million times the energy at the reference level of zero db, E_0 ; and corresponding to 60 decibels, E_2 is 1 million times as great as E_0 . When the two notes are sounded simultaneously, the reading will be R_{12} where

$$R_{12} = 10 \log_{10} \frac{E_1 + E_2}{E_0} = 10 \log(10^8 + 10^6) = 80.04 \text{ db}$$

which is sensibly the same as 80 decibels.

Proceeding in this way, we can formulate the following table, in which the two individual levels are R_1 and R_2 , and when heard together, are R_{12} :

R_1 (db)	R_2 (db)	R_{12} (db)
80.0	70.0	80.0
80.0	74.2	81.0
80.0	77.6	82.0
80.0	80.0	83.0
80.0	81.8	84.0
80.0	83.3	85.0

A convenient rule for calculations accurate to within 1 decibel is the following: If

$R_1 - R_2$ is greater than 9 db, then $R_{12} = R_1$

$R_1 - R_2$ lies between 9 and 4 db, then $R_{12} = R_1 + 1$

$R_1 - R_2$ " " 4 and 1 db, then $R_{12} = R_1 + 2$

$R_1 - R_2$ " " 1 and 0 db, then $R_{12} = R_1 + 3$

From these calculations we see that a reduction in noise level can be obtained only by first reducing the noise due to the loudest source. Eliminating sources which are of lesser intensity will cause only a slight decrease in level.

Of course, from the standpoint of noise reduction, the important question to consider is to what extent a diminution of 1 or 2 decibels is perceived by the ear. As a matter of fact, a very rough statement of the ear's sensitivity to slight differences in intensity is that it can just perceive a difference of about 1 decibel. This differential sensitivity to intensity varies with both frequency and intensity. For example, at a level of about 80 decibels above the threshold of hearing, the ear can just detect changes of about $1/2$ decibel through a frequency range of about 2,000 to 8,000 cycles; at 5 decibels above threshold, the level must be changed by about 4 decibels before it can be detected. At the low frequencies the differences must be much larger. Thus, at 50 cycles, the differential sensitivity is about 8 decibels when the original level is only 5 decibels above threshold; from 40 to 80 decibels above threshold the ear is sensitive to changes of 1 decibel or less.

The logical question to pose now is this: To what extent is the loudness reduced when reductions of 1 or 2 decibels occur? The answer may be obtained from figure 5 which is a result of a determination of an absolute scale of loudness by Fletcher and Munson (reference 3). In this experiment observers were asked to judge the relative loudness of two sounds; for example, when one sound was twice as loud as another. In this way, the relationship between loudness and loudness level was derived. Thus, if there is a reduction in loudness level of 20 phons from an original loudness level of 40 phons, figure 5 shows that the loudness changes from about 1,000 to 100 loudness units, or a reduction in loudness of 90 percent has occurred. Continuing in this way, the curves of figure 6 may be plotted (reference 6). From this figure we see that a reduction of 2 phons corresponds to a loudness reduction of about 15 percent. Small changes in loudness level produce a much larger change in the sensation of loudness. Thus, in any attempt at noise reduction, possible minor alterations, which produce but small reductions in level, should not be overlooked.

It is a matter of common experience that it is difficult to hear in a noisy environment. In table I, the relationship between the ability to carry on conversation and the noise level in various vehicles has been given. These experimental results are closely related to the auditory phenomenon of masking. If the threshold of hearing of an observer be measured in the presence of an extraneous noise having a uniform distribution of energy among a frequency spectrum which includes all audible frequencies, it will be found that his threshold is raised. The test tone must be made louder in order for him to hear it. Figure 7 summarizes the data for the masking effect of this type of noise (Fletcher and Munson, reference 3). It gives the masking in decibels, i.e., the amount the threshold at various frequencies is raised, when various masking noise levels (the numbers on the curves) are used. For example, if the noise level is 79 decibels, it raises the threshold for frequencies from about 300 to 10,000 cycles, about 52 decibels.

A pure tone may also produce a masking effect. It is found that tones of lower frequencies mask those of higher frequencies more readily than vice versa. However, a low frequency will not mask a much higher frequency in cases where the intensity of the masking tone is small. Furthermore, the masking tone may mask a lower pitched note if it is not too far removed in frequency. In the noise of aircraft, the lower frequencies predominate and are very loud. Hence, speech which contains frequencies from about 120 to 8,000 cycles is readily masked, especially those components which are most important for understanding, i.e., those between 500 and 5,000 cycles per second. The German aeronautic research group, the D.V.L., once measured the intelligibility of speech before and after treatment of a cabin (reference 30). The intelligibility increased from 6.5 percent in the bare cabin to 78 percent in the treated cabin.

In the early days of noise measurements, use was made of the masking effect to measure noise levels. By means of an instrument which measures auditory acuity, the audiometer, the threshold of hearing of the observer was measured in a quiet place. These threshold measurements were then repeated in the neighborhood of the noise source and the amount by which the threshold shifted was taken as a measure of the noise level.

Another method is one in which a known level produced

by the audiometer in one ear is compared to the noise level* to which the other ear listens. The tone on the audiometer is adjusted until it sounds as loud as the noise. If the note of controllable intensity is 1,000 cycles per second, this type of measurement will give directly the loudness level.

Before closing the discussion on sound and hearing, mention should be made of several other factors of importance. The reaction of the individual to noise is conditioned not only on its loudness, but also on its nature. Whereas people are prepared to tolerate some noise as a necessary evil in the operation of mechanical equipment, noises which are thought to be unnecessary and which should not be present can become quite disturbing. Rattling, squealing, or squeaking of the device, a low-pitched drumming, and intermittent or erratic sounds are often annoying. The reader can undoubtedly recall some sounds which he has found particularly objectionable. An attempt has been made by Laird and Coye (reference 4) to evaluate the degree of annoyance of different frequencies. They found that the annoyance increases when intensity increases and at one intensity level, the least annoying are the middle frequencies from 200 to 1,500 cycles per second.

Part of the disagreeable sensation associated with a noisy airplane arises from insecurely fastened structural members which are set into vibration. If the vibratory amplitude be sufficiently large, an audible sound will be emitted and, what is more, the passenger may experience a sensory reaction if the vibration is transmitted to where he happens to be. Just how large an amplitude is perceptible is given in the curves of figure 8 (reference 5). Here

*We take this opportunity to summarize the various terms in use as units for sound measurements. As a physical measure of the intensity of the sound or noise the three terms - sound level, intensity level, and noise level - are equivalent. The term "loudness level" is reserved for intensity measurements which have been corrected for ear response and should be expressed in phons but are often expressed in decibels. The "loudness" of a sound is an absolute measure of the observer's reaction to its intensity; it may be expressed in loudness units which are, therefore, a quantitative means of expressing the average auditor's impression of how loud the sound is.

the amplitude of vibration in centimeters is plotted against the frequency in cycles per second. The whole graph is divided into the six regions O, Ia, Ib, Ic, IIa, IIb, with the following meaning: All motions having the amplitude and frequency in the region

- O are not noticeable
- Ia, just noticeable
- Ib, well noticeable
- Ic, very strongly noticeable
- IIa, disagreeable
- IIb, very disagreeable

It will be observed that the greater the frequency the smaller the amplitude which can be detected. The vibration amplitudes of an airplane may be quite large. Zand (reference 32) reports one panel in an airplane which had an amplitude of $1/4$ inch, an extremely disagreeable source of discomfort. As a guide to be used in determining what vibration amplitudes are permissible, Zand gives the figure of 0.012 inch as the maximum amplitude to be tolerated, a figure which is considerably higher than the curves of figure 8 would indicate.

III. SOURCES OF NOISE IN AIRCRAFT

In the battle against noise, the first line of defense is a good offense; attack the enemy at its source. If possible, eliminate the noise source; if not possible, reduce its intensity. By studying all the possible sources of noise in the airplane, how they arise, the relationship between the intensity level and the different variables, and the relative magnitude of the various sources, valuable information is obtained which may be used to secure a sizable reduction in level.

Armed with a knowledge of the various physical factors involved, it is quite possible to predesign an airplane which will not exceed a specified noise level. However, having built the airplane, any changes in construction are relatively more costly. It is therefore the wis-

est and most economical course to make the initial design consistent with acoustical requirements. It is, of course, possible to correct the finished airplane, but usually this involves an increase in weight, with a consequent reduction in pay load.

Many investigators have discussed the various phases of noise reduction in aircraft. As a typical example of what can be done by paying attention to design features, Zand (reference 32) has given the data in table II. It should be emphasized that the reduction in level obtained is due to reducing the noise at the source, either by a more effective design or a proper choice of operating conditions, and not by the introduction of soundproofing materials.

TABLE II

The composition of noise in the cabin showing the improvement possible by an efficient design, excluding the use of soundproofing.

Source	Noise level in decibels	
	Inefficient design	Efficient design
1) Propeller	122	100-104
2) Exhaust	118	100-104
3) Engine clatter	104	89-99
4) Air-borne noises	108	74-79
5) Aerodynamic noise	94	79-84
6) Ventilating noise	114	72-76
Total noise	126	100-106

In particular instances the reduction possible may be more or less; the figures given are only to be considered as illustrative.

A. Propeller Noise

Extensive observations (references 10, 11, 12, 13, 14, 15, 16, 17, 18, 19, 20) on propeller noise have been made, the results of which will be briefly mentioned here. The noise consists mainly of two components. One is the rotation note, which has a frequency equal to the number of rotations per second multiplied by the number of blades in the propeller. This is the fundamental note, the low-pitched roar, and it is accompanied by a large number of harmonics (frequencies which are integral multiples of the fundamental).

Usually there is more acoustical energy in the fundamental than in all other frequencies, so that it is the chief cause of propeller noise. However, in certain cases (reference 11) the harmonics may predominate.

The other component is the rotation or vortex noise. As the propeller rotates, it causes a turbulent air condition to be set up, in which vortices are shed off the blades. The vortex motion gives a very complex frequency spectrum composed of a continuous distribution of frequencies from about 1,000 cycles up.

It is also found that the rotation noise and vortex noise are not equally intense in all directions about the propeller. The maximum intensity level occurs in the plane of the propeller blades and is due to the fundamental note. The vortex noise, on the other hand, has its maximum along the axis of rotation of the propeller. However, the frequency discrimination of the ear is such that the propeller noise is equally loud in all directions (Stowell and Deming, reference 20).

It is evident that proper positioning of the cabin relative to the propeller is of advantage. Both the sound intensity and the vibration amplitude of structural elements decrease with distance from the source of the disturbance. Some data of Bruderlin (reference 22) (fig. 9), give the variation of noise level, at the skin of the fuselage, with distance from the propeller, showing that a 10-decibel reduction may be obtained by placing the cabin 16 feet back from the plane of the propeller. If there is too little clearance between the fuselage and the tip of the propeller, the vibration amplitude of the fuselage will be larger and the noise level will be higher. The noise level varies as $\frac{1}{r^{2.5}}$, where r is this clearance distance (Bruderlin, reference 21), provided r varies from 8 to 12 inches. In one specific case (Zand, reference 32), a 2-inch clearance between the propeller and a certain panel caused the latter to vibrate with an amplitude of 1/4 inch, and as a result it was the cause of most of the noise in the cabin. To reduce the noise being emitted, a floating panel was attached to it by means of rubber strips. The amplitude of the floating panel measured 0.015 inch and the sound level dropped 10 decibels. This same reduction could have been obtained by having a clearance of 12 inches, had that been possible.

Multiple-engine airplanes with an even number of engines are to be preferred, as it is possible in this case to have the cabin situated farther away from the propellers than is usual. The cabin, however, should not be located in the plane of the propellers, since this is exactly where the rotation noise, which is hardest to insulate against, is a maximum.

The single most important determinant of propeller noise, however, is the propeller tip speed. Most authors are agreed that a linear relationship exists between noise level in decibels and propeller tip speed. Zand (reference 32) finds that the noise level in decibels for a two-blade metal propeller is

$$\text{Noise level (db)} = 24 + 0.11V \quad (4)$$

where V is the tip speed in feet per second. For a three-blade metal propeller the equation is, approximately,

$$\text{Noise level (db)} = 19 + 0.11V \quad (5)$$

The actual law is plotted in figure 10. The relations (equations (4) and (5)) seem to hold up to about $V = 850$ feet per second, when the sound level starts to increase faster than a linear law. Somewhere in the neighborhood of this speed, which is an appreciable fraction of the velocity of sound, the flow of air past an airfoil similar in design to a propeller section changes from smooth flow to "burbling type of flow which at low speeds occurs only at large angles of attack (reference 33)." This results in a decided change in the character of the sound with an apparent increase in intensity. Hilton (reference 14) has indicated that the linear law extends well on past the velocity of sound. He found that the noise level is directly proportional to tip speed in the range from 0 to 1.2 times the velocity of sound.

Obata and co-workers (reference 19) carried out an extensive series of observations on the intensity of different frequency components of the propeller noise as a function of tip speed and pitch angle of the blades. While the intensity does not vary in a simple fashion with the pitch, it is possible to make the rough statement that the sound level decreased 1 decibel for each degree decrease in pitch over a range from about -10° to $+10^\circ$ pitch setting.

Davis (reference 25) has given the following rules:

"Noise reduction of

- 10 db per 100 ft./sec. reduction in tip speed (some airscrews gave higher reductions up to 15 db).
- 1 db per degree decrease in pitch setting.
- 10 db for change to thin conventional section.
- 5 db per foot diameter increase of airscrew (for given power, forward speed, and similar operating point on the efficiency curve).
- 10 db for change to 4-blader of same diameter (for given power and appropriate speed). (The change from a 2-blader would, of course, involve a change of gear ratio and calculations have shown that there will be no actual improvement if the gear ratio is kept fixed.)"

A formula giving the noise level as a function of tip speed, distance of observation point from propeller, the number of blades, propeller radius, chord of blades, blade shape, angle of incidence of air stream, and air viscosity has been given by Capon (reference 23). There is some doubt as to its complete accuracy, as it has been assumed in this derivation that the sound intensity diminishes with the distance according to the familiar inverse square law. Several observers (references 19 and 20) have found experimentally that the intensity decreases more rapidly than this. The reader is referred to the original paper by Capon for the formula and its use.

The most effective way to reduce the noise level of an airplane is, then, to reduce the propeller tip speed, use large-blade propellers and preferably with more than two blades. In most cases the reduction of tip speed is accomplished by gearing the propeller to the engine. Care should be taken that the noise level of the gears is below that of the propeller noise. As an example of the advantage in gearing, we quote some figures of Davis (reference 25), in which a geared and an ungeared engine are compared. The tip speed of the ungeared airplane was 830 feet per second, while that of the geared airplane was 685 feet per second; the reduction was, on the average, about 13 decibels. In any event, the tip speed should not be permitted to exceed 850 feet per second, at which speed

the curves of figure 10 show that the sound level gets inordinately large.

B. Exhaust and Engine Noise

Usually the propeller noise is much louder than the exhaust noise. If the difference in intensity between the two is more than 10 decibels, then we have seen that even if we entirely eliminated the exhaust noise, the sound level would be unchanged. Thus, there is no point to reducing the exhaust noise unless it is louder than the propeller noise. Of course, some reduction (1 to 3 db) may be obtained in case the exhaust is no more than 9 decibels below the propeller noise. Before any reduction in level can be obtained, it is always necessary to first reduce the loudest offender.

In certain aircraft, where the tip speed is still relatively large, the exhaust needs no special mufflers or silencing device. The usual procedure is to use exhaust collectors, with the exhaust-pipe outlet located well away from the cabin so that the screening effect of the nacelles or wings is used to good advantage. Increasing the distance from the cabin is also of advantage since the sound intensity decreases as the inverse square of the distance, approximately.

In the event that in some way the contribution from the propeller has been reduced below the level of the exhaust, some kind of silencer will be necessary. The National Bureau of Standards has conducted an investigation to discover the nature of the action of a muffler and to test the effectiveness of various commercial and experiment mufflers (references 33 and 34).

Analysis of the action of the ordinary muffler showed that it acted by modifying the flow of gas so as to generate less sound, but did not act to absorb the sound after it had once been created. The working principle of some of the mufflers was chiefly one of reducing the temperature of the exhaust gas by an expansion chamber or by a large metal radiating surface. In addition, in some of these mufflers a turbulent gas flow, which caused convection currents, increased the rate of heat loss. When the temperature dropped, the density of the gas increased, as a consequence of which for a given energy of flow, the velocity of discharge of the gas was reduced. In the re-

sistance type of muffler, the flow of gases was retarded so that a back pressure was exerted on the engine with a consequent loss of power. Mufflers of this type are too heavy.

There are several types of mufflers which are built for the purpose of attenuating the sound produced. In one, use is made of sound-absorbent material which is able to withstand the heat of the exhaust gases. Another type has built into it an acoustic filter, a device which discriminates against certain frequencies present in the exhaust noise, so that these frequencies are attenuated. Measurements on one type of engine (reference 34), an 80-horsepower, V-type, 8-cylinder, water-cooled, Hispano-Suiza engine indicate that the exhaust sound energy is concentrated in the frequencies below 250 cycles and greater than 500 cycles. Hence, the acoustic filter should be designed to dissipate these two frequency regions.

One important conclusion of this investigation was that considerable reduction could be obtained merely by the use of a manifold system. Thus 7 decibels was gained when a side manifold tube 3 inches in diameter and 31 inches long was connected to the exhaust port. Four open ports, 2 inches in diameter, were provided on the side manifold. A more complicated device containing a Siamese fitting between the exhaust port and the side manifold attenuated the noise 13 decibels. This indicates the order of effectiveness of such a simple device as a collector and a tail pipe. Of the 10 mufflers tested, half of them had a reduction of about 5 decibels; the other five were responsible for 10 decibels loss. The loss in horsepower, due to the addition of the mufflers, was less than 2 percent, while the manifold system was responsible for a 1- to 3-percent loss.

It should be pointed out that the data on mufflers were obtained in the laboratory in a test set-up in which the propeller was purposely excluded, so that only exhaust noise would be measured. In any practical attempt at airplane quieting it is desirable to know just which component, propeller or exhaust noise, is louder, and it is of advantage to make such observations on the finished airplane. A method of separating the components has been indicated by Spain, Loye, and Templin (reference 28). Some of their results are given in a later section of this paper (p. 49).

Engine noise, in which we may include valve and tappet clatter, gear, carburetor, and supercharger noise, is usually below the level of the exhaust. Some figures we have already quoted (p. 15) and some obtained at the National Bureau of Standards (reference 34), indicate that the difference is about 14 or 15 decibels. Naturally, the engine may cause a great deal of disturbance because of vibration transmitted to the cabin structure. Care should be taken therefore to secure a proper elastic suspension for the engine. Zand (reference 32) states that a reduction of 2 or 3 decibels was obtained in one particular installation in which a resilient mounting was used. He advocates the use of rubber under shear for mounting purposes, as it gives a greater vibratory attenuation than the ordinary rubber under compression. A method of calculating the load on the rubber supports is also given by Zand. Of course, it is of advantage to have the suspension fittings as close as possible to the center of gravity of the engine. Additional refinements from the quieting viewpoint are flexible pipes and tubing between the engine and the nacelle, the rigid wall of ordinary pipe lines being more apt to vibrate than the discontinuous structure of a flexible conduit.

A particularly disconcerting effect which may be obtained in multiengine installations is the phenomenon of beats between engines. These occur when two engines are running at slightly different speeds; the net effect is a fluctuation in intensity which may be as great as 10 decibels. In the modern Douglas airplanes (Bruderlin (reference 21)), synchronization controls are provided whereby beats are kept less than 1 in 4 seconds. Beats may also occur between different frequencies present in the complex structure of airplane noise. When they occur and are sufficiently loud to be disturbing, the appropriate remedy is to change the frequency of the mechanical motion responsible for the generation of this note.

C. Aerodynamic and Ventilating Noise

The advent of streamlined aircraft, marking the relegation of the "stick and wire" structure and other aerodynamically faulty airplanes to obsolescence, has made the aerodynamic noise level an unimportant factor compared to propeller and engine noise. If the lines of the airplane hull are kept clean, and obstructions or protrusions which would cause excessive air turbulence are eliminated, noises

arising in this manner will not be troublesome. Precautions to be taken in this category are the avoidance of leaks or openings in windows or doors and their appropriate installation to assure continuity of streamlining.

Under flight conditions, with variable stresses acting on the fuselage and door, it is possible for slight openings to appear where a perfect closure existed on the ground. Such openings introduce a new source of noise because of the turbulent state of the air at these small cracks and because they transmit an inordinate amount of sound into the cabin. An effective door catch should exert pressure on all four sides; there are several such devices on the market. There is also a type which has a pneumatic gasket which is capable of expansion upon reaching a given elevation (Zand, reference 32).

In ventilating systems for aircraft, we have a perplexing problem in which, apparently, the demands of good ventilation are diametrically opposed to those of keeping the cabin quiet. To get the required air flow, rather large ducts must be used, and if these be employed, sufficient sound may be transmitted into the cabin from the noisy exterior to make the interior equally loud. Similar requirements arise in air conditioning, heating, and ventilating units for ordinary building construction. The designer in this case turns to the use of sound-absorbing materials which he employs as a duct lining. In the Curtis-Wright "Condor" (Golding, reference 27), such a ventilating system is used. The ducts consist of two concentric tubes; the inner tube is perforated and the space between the two is filled with glass wool which has good sound-absorbing properties. As the air stream passes through the center pipe, the associated noise is attenuated. In general, the attenuation or diminution in sound level is directly proportional to the length of the duct. For example, if there is a decrease of 10 decibels for 10 feet, there will be a 20-decibel loss for 20 feet. It is therefore evident that to keep the noise level low in the airplane, the intake opening should be as far as possible from the point where the air is discharged into the cabin. Furthermore, the intake should be located in a relatively quiet spot, say under a wing, away from the propeller.

The attenuation per unit length varies with frequency for any given lining and duct opening and is usually smaller at both the low and the high frequency ends. There may sometimes be some residual sound, a tearing or swishing

type of noise. To remedy, recourse should be had to a frequency analyzer to determine the frequency or frequencies present. An acoustic filter (p. 188, reference 36) may be the proper solution if too wide a frequency range is not present in the analysis.

In certain instances, the difficulty may arise from a resonant effect, i.e., if the length of the ventilating pipe is a multiple of one-half wave length ($1/2$, $2/2$, $3/2$, $4/2$, ...) of the sound wave concerned; then the pipe will be in resonance and the attenuation will be much less. Figure 11 (Schoch, reference 38) shows this effect. The influence of an opening of 15 centimeters length and 1.7 centimeters diameter on the sound insulation of a brick wall was ascertained. Curve a represents the sound insulation of the wall without hole, and curve b with the hole. The hole is essentially a tube of 15 centimeters length and will resonate at certain select frequencies, namely, those for which the wave length of the sound is 2, $2/2$, $2/3$, $2/4$, ... times the length of the pipe. The first frequency in the series is approximately 1,150 cycles/

second (frequency = $\frac{34400}{2 \times 15}$; the velocity of sound is 34,400 cm/sec.). Succeeding frequencies will therefore be 2,300, 3,450, 4,600, ... The arrows on the curves of figure 11 show the minima which occur approximately at these frequencies. It will be seen that 10 to 15 decibels more sound is transmitted at these frequencies than at others.

This resonant effect may become serious in some installations if the tube length is such as to resonate at the low frequencies from which airplane noise gets its loudest contribution. Thus a 6-foot length resonates at 94 cycles, and a 12-foot length at 47 cycles. In modern airplanes the fundamental of the propeller note is low because of the reduced tip speed, but usually not lower than 45 cycles per second, so that if ventilating pipes be kept longer than 12 feet, this anomalous transmission effect will not occur. Of course, if the pipe length is short, the higher frequencies will resonate and they are usually less objectionable than the lower tones. A frequency analysis of the offending residual sound will show if it has the frequencies associated with the length of the pipe. This length may be changed so that maximum attenuation is obtained by making the new length $1/4$, $3/4$, $5/4$, ... of a wave length. That is, if l = length of tube, and L =

the wave length, minimum attenuation occurs when $\lambda = \frac{2L}{4}$, $\frac{4L}{4}$, $\frac{6L}{4}$, ... and maximum attenuation when $\lambda = \frac{L}{4}$, $\frac{3L}{4}$, $\frac{5L}{4}$, ...

The lengths of maximum transmission occur halfway between those for minimum transmission.

The size of the conduit which should be used is determined by the rate at which air is to be supplied to the cabin and the maximum speed of flow commensurate with passenger comfort. Zand (reference 32) states that 15 to 20 kilometers per hour is "the maximum speed of air which will not create draughts" and that 30 cubic feet of air per person per minute will do in normal weather, while on very hot days, up to 60 cubic feet is necessary.

D. Secondary Noise Sources

The term "secondary noise sources" refers to noise arising from vibrating objects in the cabin, such as bulkheads, floors, baggage racks, chairs, and other auxiliary equipment. These give rise to air-borne sounds which may be particularly objectionable, as they are, in general, intermittent in nature. Furthermore, vibration of furniture or floors may give passengers an unpleasant vibratory sensation.

The fuselage of an airplane is subjected to sudden changes in stress, to shocks, and to vibratory motion arising from prime movers and intense sound waves. If any cabin fixtures be connected directly to the fuselage, they will be set into vibration. To remedy this undesirable condition, it is well not to mount cabin equipment on the fuselage directly or, if this is necessary, to use shock-absorbing mountings of rubber, felt, or any other vibration damping material. Floors, for example, should be mounted on an isolation system, say, of rubber, felt, or cork pads. Panels of the cabin trim should be fastened rigidly, and any large unsupported structural elements should be avoided, as they will readily cause a low-pitched drumming effect. The ideal cabin, from this viewpoint, is one in which no part is compelled to take the stresses to which the airplane is subjected. Intercabin bulkheads or any other internal bracing can be readily avoided by the use of monocoque constructions or "self-supporting U- or Z-shape rings (Zand, reference 32)."

Windows, if attached directly to the cabin trim, will

create a high-pitched disturbance in the immediate vicinity of the passenger. Appropriate rubber fittings for mounting the windows are available on the market. One patented construction, figure 12 (Zand, reference 32), provides a rubber channel into which the glass is inserted. Provision is made for the rubber to move in two directions, both laterally and vertically, so that the vibration is readily attenuated. The energy dissipation of such a material arises from its ability to change its shape under a load. Actually, if the rubber is not too soft, it will be found that it is almost incompressible when confined. It is, therefore, well for the designer to allow rubber or other resilient supporting material room for expansion or contraction.

Other minor pieces of equipment, "such as ashtrays, drinking glasses, mirrors, fire extinguishers, and seat belts" should be securely fastened to the cabin to eliminate the possibility of their rattling or buzzing. Eternal vigilance is the price of keeping these annoyances from cropping up. Mountings and fittings should be periodically inspected.

Attention to details when installing cabin equipment will pay. Secondary noises, then, may be kept to a minimum. With the principles detailed under the other sections A, B, and C, the designer may choose his operating conditions and pattern his design so that a material reduction in noise level of about 20 decibels is obtained. His untreated cabin, however, is still much too noisy, the level being about 100 to 105 decibels. For comfortable surroundings and unimpeded ability to converse, the sound intensity should be reduced to that in the V-16 and V-12 passenger cars of table I, i. e., between 79 and 84 decibels. A further reduction of anywhere from 15 to 25 decibels, and in some cases 30 decibels, may be necessary. For this, recourse must be had to the principles of sound insulation and sound absorption. We shall show that by making use of these two principles, it is possible to gain up to 30 decibels for a reasonable amount of additional weight. However, before discussing this phase of the problem, we should like to round off our present discussion by giving some additional means available to secure a reduction of noise level without soundproofing.

One of these schemes has been indicated by Bruderlin (reference 21). He found that by curving the fuselage section, less low-frequency sound would be transmitted

into the airplane than if the section were flat. Thus, in the DC-2, a deformation of the section to a 50-inch radius produced an improvement of $6\frac{1}{2}$ decibels at 50 cycles per second, while a 100-inch radius was $2\frac{1}{2}$ decibels better than a flat section. The appropriate radius is, of necessity, a compromise between decibel gain and necessary interior space. Analyses of the distribution of noise in the cabin have shown that the front of the airplane is, in general, noisier than the rear. For example, current practice among airplane manufacturers (reference 35) indicates that sound levels run from about 83 to 91 decibels in the cabin and 85 to 102 decibels in the pilot's quarters. It therefore follows that baggage rooms or mail compartments should be placed in between cabin and cockpit, so that the cabin is removed from the noisiest part of the airplane. On the other hand, rest rooms should probably be well in the rear, toward the quiet end since, for the passenger who is sick or desires rest, a noisy environment will accentuate his discomfort.

IV. SOUNDPROOFING THE AIRPLANE

A. The Noise-Reduction Factor

The process of soundproofing is dependent upon two different physical phenomena, sound absorption, and sound insulation. Just where the distinction arises may be seen from the following illustration. Imagine yourself the owner of a boiler factory. The din is terrific; workmen are subjected to the enervating effect of unceasing noise. Furthermore, the people who are unfortunate enough to live in the neighborhood are complaining: "Your factory is unbearable." You have two distinct problems to solve: one is to reduce the sound level within the building in order to relieve your employees, and the other is to prevent the noise from leaving the building - for the relief of your neighbors.

If you think you would first like to set your neighbors at ease, then what you must do is to change the construction of your walls so that they become more effective sound insulators. It is possible to achieve this increased efficiency in several ways, one of which is to increase the weight of the walls considerably. The heavier wall transmits less sound, but to secure all of the additional insulation desired a more complicated solution may be necessary.

However, having built this wall has not given respite to your workmen; the noise is still just as loud on the inside. Recourse must be had to sound-absorbing materials, the application of which to the walls of the interior will afford a material reduction in loudness. Furthermore, the use of absorption in the interior also helps to reduce the sound-level exterior to the building. If the sound level is reduced 5 decibels on the inside, it will also be 5 decibels less on the outside. In this sense, the utilization of sound absorbents may be said to have some sound-insulating value. However, since it is usually not possible to secure a reduction of more than 7 decibels by this means, it is necessary to make special provision for sound insulation.

Of course, in quieting an airplane, the point of view is reversed; the noise exists externally to the airplane and what is desired is to prevent the transmission of sound into the interior. However, having once penetrated into the cabin, acoustical materials may be applied so as to diminish the sound level. Soundproofing a cabin thus resolves itself into an attack on two fronts, the objectives of which are: "Keep the noise out and keep the noise down." On which of the two battlegrounds the stronger efforts should be exerted will be evident from consideration of the noise-reduction formula which we now deduce.

As an approximation to the actual physical situation encountered under flight conditions, the following set-up is considered. We have a cabin which may be thought of as a large box, this box being suspended inside of a still larger box. A source of sound is situated exterior to the cabin, as a result of which there will exist a certain sound field in the space between the two boxes; it is assumed that at all points in this field there exist equal amounts of sound energy. The total amount of sound energy present in the space exterior to the cabin will be denoted by E_e , and the amount of sound energy which is incident on unit area of the cabin surface on its exterior side in unit time, will be E'_e . Of these E'_e units of sound energy, only a certain fraction will be transmitted into the interior of the cabin. The fraction of the incident energy which is transmitted into the interior of the cabin is known as the transmissivity, and will be designated by the symbol τ . Hence, per unit time, the total energy appearing in the cabin is $\tau E'_e S$, S being the total surface area. Within the cabin there exist E_i units of

energy, as a result of which E'_i units of energy hit unit area of the interior in unit time. The cabin is lined with a surface finish which has a sound-absorption coefficient α . This means that of the E'_i energy units striking unit area of S , a certain fraction, α will be absorbed. Hence, $\alpha E'_i S$ units of energy are absorbed in unit time. In addition, there is also a certain transmission of energy from the interior of the cabin to the exterior, i.e., of the $E'_i S$ energy units incident on the interior surface $\tau E'_i S$ energy units appear externally. When equilibrium is attained, there must be just as much energy appearing as is disappearing in the cabin, so that we have:

$$\tau E'_e S = \alpha E'_i S + \tau E'_i S \quad (6)$$

whence

$$\frac{E'_e}{E'_i} = \frac{\alpha S + \tau S}{\tau S} \quad (7)$$

The sound energy striking the cabin wall on its interior side is a function of the total sound energy present in the interior of the cabin; in fact, it is possible to show that in the ideal case assumed here the two are proportional. Similarly, the sound energy incident on the exterior side is proportional to the energy exterior to the cabin, so that

$$\frac{E'_e}{E'_i} = \frac{E_e}{E_i} \quad (8)$$

The difference in sound level in decibels between the outside and the inside is known as the noise-reduction factor and is equal to $10 \log_{10} \frac{E_e}{E_i}$, so that the

$$\text{Noise reduction in decibels} = 10 \log_{10} \frac{\alpha S + \tau S}{\tau S} \quad (9)$$

A surprising fact will at once be evident from equation (9). If there is no absorption within the cabin, i.e., $\alpha = 0$, the sound level within will be equal to that without, no matter how effective the wall is in preventing the transmission of sound. Physical considerations show at once why this must be so. Any sound energy which does get into the interior is not absorbed and hence

will persist for a very long time. (There will be some loss at each incidence on the cabin wall due to transmission through the wall; hence it will not persist indefinitely.) As more and more energy is transmitted from the outside, the sound level will continue to increase until the external and internal intensities are equal. Equilibrium will then set in and the two sound levels will be equal. Thus, it is necessary to have some absorption in the cabin, else an effective insulation scheme will be of no avail.

It will be noticed from equation (9) that to obtain large sound reductions, we must have a low transmissivity and a high absorption coefficient. Figure 13, in which the decibel reduction calculated from equation (9) is plotted for different values of τ and α , illustrates this fact. (Cf. fig. 3, reference 33.) It will be seen that the maximum reduction occurs at the lowest transmissivities and the highest absorption coefficients. Furthermore, if there is very little absorption, the reduction is small. However, for low transmissivities the reduction increases much more rapidly for small values of α than for the same values of α at larger values of τ . Thus changing the absorption coefficient from 0 to 0.2 results in a change of 23 decibels for $\tau = 0.001$, of 13.3 decibels for $\tau = 0.01$, of 4.7 decibels for $\tau = 0.1$, and of 0.8 decibels for $\tau = 1$. On the other hand, if we change from $\alpha = 0.2$ to $\alpha = 1$, we get less varied reductions for the various τ 's, i.e., 7.0 decibels for $\tau = 0.001$, 6.7 decibels for $\tau = 0.01$, 5.3 decibels for $\tau = 0.1$, 2.2 decibels for $\tau = 1$. For the same increase in α , the decrease in the sound level within the cabin is greatest for low transmissivities.

Another important consideration which is evident from these curves will be illustrated by the following example: Suppose $\alpha = 0.1$ and $\tau = 0.01$; the noise reduction is 10.4 decibels. If we wish to gain another 10-decibel reduction, we may do one of two things: change the interior treatment so that the absorption coefficient increases from 0.1 to 1, or, keeping α fixed at 0.1, change the cabin wall structure so that τ decreases to 0.001. Either of these treatments will result in a further decrease in level of 9.6 decibels. The answer to the question as to which of these two possibilities is most advantageous depends on the relative weights of the proposed treatments; the best solution is that which requires the least additional weight, other things being equal. In any particular

case in which it is contemplated making a choice between decreasing τ or increasing α and in which the weights of the proposed treatments are known, the most appropriate answer can be readily obtained from the noise-reduction factor.

The above theoretical development is to be considered only as a very approximate one. It deals with a highly idealized cabin, which may be considered very simply as an empty room, devoid of any accessories and having all sides of uniform construction and surface finish. Under these circumstances, the transmitting and absorbing surfaces are the same, and the transmissivity and absorption coefficient do not vary from wall to wall. In our real cabin, however, the transmitting and absorbing surfaces are not equal. The cabin floor may have little absorption value but may be a very effective insulator. People, upholstered seats, various furniture pieces within the cabin have some absorbing ability. Furthermore, α and τ vary in different parts of the cabin. Glass windows have absorption and transmission coefficients (α and τ) which differ from that of the other cabin units, such as walls, bulkheads, floors, etc. Equation (9) may be modified to take these various factors into account. The total absorption in the room is not αS but a sum of the terms $\alpha_1 S_1 + \alpha_2 S_2 + \alpha_3 S_3 + \dots$, where α_1 is the absorption coefficient of a surface which has S_1 units of area, α_2 the absorption coefficient for S_2 units of area, etc. Similarly, the total transmission is given by $\tau_1 s_1 + \tau_2 s_2 + \tau_3 s_3 + \dots$, where $\tau_1, \tau_2, \tau_3, \dots$ are the transmissivities for the different surfaces having the area s_1, s_2, s_3, \dots

If we let $A = \alpha_1 S_1 + \alpha_2 S_2 + \dots = \text{absorption}$

$T = \tau_1 s_1 + \tau_2 s_2 + \dots = \text{transmittance}$

we get for equation (9):

$$\text{Noise reduction (db)} = 10 \log_{10} \frac{A+T}{T} = 10 \log_{10} \left(1 + \frac{A}{T} \right) \quad (10)$$

For reductions greater than about 20 decibels $\frac{A}{T}$ is much greater than 1, so we get

$$\text{Noise reduction (db)} = 10 \log_{10} \left(\frac{A}{T} \right) \quad (11)$$

B. Sound Absorption

To calculate the noise reduction one may obtain in any soundproofing scheme, it is necessary to know the absorption coefficient and transmissivity of the materials used. Methods are available to determine both of these quantities in the laboratory. The most reliable test procedure for determining α , now in use, is the reverberation-room method, in which the time it takes for sound in a room to decay through a specified number of decibels, is measured. Sabine first showed that the total absorption in a room, A , is related to the time of decay for a range of 60 decibels (the so-called "reverberation time" T) and to the volume of the room V , by the formula

$$T = \frac{0.05V}{A} \quad (12)$$

where T is in seconds and V in cubic feet. Thus, to determine α , it is necessary to measure the reverberation time with a known amount of material in the reverberation chamber. Correction must be made for the absorption of the empty room.

There are several features of importance about sound-absorbing materials which should be pointed out. Absorption of sound energy may occur in either of two ways: through porosity or diaphragm action. A material which is effective because of its porosity, consists of a great number of intercommunicating pores, fissures, or cells. The sound wave incident on the surface penetrates into the interior by means of the small openings in the material but, in traveling down these capillaries, the wave motion is resisted by a viscous drag exerted by the capillary walls. As a result, some of the energy in the wave is dissipated by this frictional force and is converted into heat. It is at once evident what the effect of thickness is. If the material is too thin, the wave will be reflected off the back surface after having been only partially dissipated, so that considerable energy will be reflected back into the room. If the material is thick enough, the wave may be absorbed to such an extent that what is finally returned to the room is considerably attenuated.

Some figures given by Knudsen (p. 191, reference 37), show the effect of thickness on the absorption of Balsam Wool at different frequencies. These are given in table III.

TABLE III

Variation of absorption coefficient of Balsam Wool with thickness and frequency (cycles per second)

Thickness	Absorption coefficient at frequencies of:				
	128	256	512	1024	2048
1/2 inch	0.06	0.22	0.41	0.58	0.57
1 "	.10	.25	.46	.62	.60
2 "	.21	.38	.58	.69	.70
4 "	.34	.48	.65	.75	.76

It will be seen that the greatest increase with thickness occurs at the lower frequencies. While no general conclusions are valid for all materials, a very general statement can be made which covers the action of all porous materials, viz, the absorption coefficient is roughly proportional to thickness for a frequency of 128 cycles per second for thicknesses as large as 3 or 4 inches. Above this frequency, for thicknesses greater than 2 inches, the coefficient is approximately constant, but may increase slightly; for smaller thicknesses the variation with thickness is usually not predictable.

In the phenomenon of diaphragm action, the acoustical material vibrates in such a fashion as to absorb energy from the sound wave. Since it requires energy to maintain this vibration, the reflected wave from the material is considerably attenuated. Whether a material is free to vibrate or not depends on the manner in which it is mounted on the wall which it covers. If it is mounted rigidly, it cannot show this diaphragm action, provided the wall itself is rigid. However, if it is mounted on wood studs, or fastened by any other similar means, so that the individual unit is held fast only at its edges, then it has the possibility of behaving like a diaphragm. An important consideration, therefore, in giving absorption coefficients is to state just how the materials were mounted when tested. The application of such data to other types of mountings is usually unreliable and incorrect. For example, the following data were taken at the National Bureau of Standards (p. 5, reference 2) on a certain acoustical tile

(Acousti-Celotex, type C2, 11/16 in. thick) which was stuck on gypsum wallboard by means of an adhesive. The wallboard was placed on the floor of the reverberation room and tested. It was also tested after it had been nailed on to 13/16- by 2-inch furring strips 12 inches on center. The results are as follows:

Mounting	128	256	512	1024	2048	4096
Cemented onto wallboard	0.11	0.31	0.71	0.80	0.67	0.57
Nailed to furring	.14	.65	.63	.73	.67	.55

The diaphragm action is especially evident at 256 cycles per second.

In this connection it is well to note one other point. If the material is tested in the laboratory in small individual tile units and then, in the actual installation, is applied in larger units, the use of laboratory coefficients may be inaccurate, especially at the lower frequencies. At these frequencies the tile may be in resonance (normal vibrational modes), and since these resonant effects depend on the size of the unit the coefficient will be different for the two tiles. In fact, laboratory data obtained at frequencies of 128 cycles or less may not be too close to the actual coefficients which obtain under the condition of mounting in an airplane, since at these frequencies there is considerable vibration of the airplane. This is, of course, only true for those materials which are sound absorbers by virtue of their vibratory characteristics.

Some commercial products are manufactured to give this diaphragmatic absorption. In general, they consist of a flexible external sheet of some kind - paper, wood, doped fabric, or metal foil backed up by an air space. One of these is "vibrafram," which comes in 13- by 13-inch units, and has a stiff sheet of felted paper shaped to form a sort of hollow pan. The base is arranged with a lip so that it can be pasted onto any surface desired.

It is the characteristic of this type of absorption scheme that the coefficient is a maximum at one frequency and tapers off at all others. The graph of absorption coefficient versus frequency is resonance-like in nature. What is taking place is, that at a certain frequency resonance occurs, as the combination of vibrating diaphragm

plus air-space forms, in effect, a mechanical system of a mass on a spring, in which the diaphragm may be considered as the mass and the volume of air enclosed by the vibrating membrane as the spring. That is, the enclosed volume of air acts as if it possessed stiffness, and this latter is the property of a spring.

Meyer (reference 8) has shown that if a wall is covered by a stiff membrane of this kind, of mass m per unit area and distance l from the wall, the resonant frequency is given by the following formula:

$$f = \frac{188}{\sqrt{m l}} \quad (13)$$

where f is in cycles per second, m in grams per square centimeters, and l in centimeters. Figure 14 gives the results of Meyer's measurement on brown wrapping paper placed at a distance of 5 centimeters from the wall. Curve a is with the air space, and curve b is with the space partially filled with cotton waste. The cotton was introduced in such a fashion that it did not touch the vibrating diaphragm. Its only effect was to absorb the sound waves which were produced in the air space, especially those waves traveling in a direction parallel to the face of the paper. By using several layers of material separated by an air space, it is possible to get good low-frequency absorption over a fairly wide range. Figure 15 (Meyer, reference 8) shows the results obtained in an arrangement using three layers of oilcloth, with an air space of 5 centimeters between each layer. The theoretical explanation of this action is based on the mechanical analogy of this arrangement to an electrical filter which passes high frequencies only.

While porous materials are generally inefficient at the low end of the frequency range, but are much more absorbent at the higher frequencies, those arrangements depending on diaphragm action have a maximum absorption at the low end. To obtain good absorption over the whole range, the logical procedure would be to attempt to combine these two effects. This may be done, as we have already pointed out, by using a mounting for the porous material which will permit vibration, if the material is sufficiently rigid to be capable of vibration. Another possibility is one in which the porous material is attached to a stiff membrane so that absorption occurs due to both porosity and vibration. For example, some figures

obtained at the National Bureau of Standards on a commercial product "Limpet," which is sprayed asbestos mixed with a binder to make it cohere, are given below. The asbestos was sprayed on metal lath, thus making possible diaphragmatic motion; and also on wallboard, in which case the absorption would be due to porosity only.

Mounting	Absorption coefficients of sprayed asbestos					
	128	256	512	1024	2048	4096
Sprayed on wallboard	0.13	0.31	0.66	0.83	0.74	0.66
Sprayed on metal lath and surface painted	.57	.71	.80	.56	.51	.52

The thickness of the layer was $3/4$ inch. There was approximately a 3-inch air space behind the metal lath. The much higher absorption coefficient resulting from diaphragm action is evident at the lower frequencies. The Limpet sprayed on metal lath was painted with several coats of paint. This causes a reduction in the coefficients at the three higher frequencies since the paint film prevents entrance of the sound wave into the pores in the interior of the material. On the other hand, it stiffens the surface of the material, so that the membrane action is enhanced at the lower frequencies. In another sample, in which Limpet was sprayed on metal lath and then painted, the absorption at the high frequencies was not reduced because of the existence in the painted surface of a great number of holes which permitted penetration of the wave directly into the air space. Once in the air space, the sound experiences a dissipative effect at the absorbent undersurface of the sprayed asbestos, and hence the absorption throughout the whole frequency range is increased. The material, Washkote, developed by Johns-Manville (reference 32) combined these two principles, porosity and diaphragm action, to produce an absorbent which was effective at all frequencies.

Some other arrangements have been given by the German investigators, Wehner and Willms (reference 30). For example, they used a 3-millimeter plywood sheet, perforated with 2-millimeter diameter holes, and backed up by 6-millimeter Calmuc (German trade name of a porous material) and a 50-millimeter air space. This arrangement shows a reso-

nant effect depending on the distance from the wall. At the wall a standing wave system is set up, and the particle velocity of this wave is a maximum at a distance of $1/4$ wave length (of the frequency concerned) from the wall. The amount of sound energy dissipated depends on the viscous resistance of the pores, and this is a maximum when the particle velocity is a maximum, so that at a distance of $1/4$ wave length the absorption coefficient will be greatest. At frequencies between 400 and 1,000 cycles per second this set-up gives a coefficient of about 90 percent, while at 100 cycles the absorption is only 10 percent. Of importance is the acoustical resistance of the backing layer. For best results it should match that of the air, i.e., 42 acoustical ohms.

Wehner and Willms also report some measurements in which coefficients close to 100 percent were obtained over a narrow band of frequencies. These were all resonant arrangements similar to Meyer's, the only difference being that on the back of the surface membrane (either perforated plywood or oilcloth) felt was applied. However, the absorption coefficient at other frequencies was less than 10 percent. For example, the oilcloth-felt arrangement with a 50-millimeter air space, gave the following coefficients at 100, 200, 300, 400, 500, 600, 800 cycles per second, respectively: $\alpha = 0.04, 0.03, 1.00, 0.65, 0.45, 0.25, 0.03$.

It is well to observe here that any surface covering applied over the face of a material is apt to change its coefficient. If the covering is very open, such as any perforated metal, wood, or fabric, or any open-weave cloth, the coefficient may change either way, i.e., increase or decrease, but usually not very much. In soundproofing airplanes the practice is to use pads or blankets of lightweight fibrous materials which are placed between the outer skin and the cabin trim. The trim may be a very open fabric, or perforated sheet of some kind, in which case the laboratory coefficients are probably unchanged; or the trim may be a heavy mohair, leather, or fabric of some kind. In the latter event, since the surface of the blanket is effectively screened by the external covering, the laboratory coefficients are no longer valid, unless the absorption has been measured with the particular covering actually used in the cabin. In some cases the materials may be covered with a special waterproofing finish or sheet, so that the effectiveness of the material will be practically all vitiated. The moral is: beware of extra-

neous surfaced finishes which prevent the penetration of sound into the absorbent; in any event, a test of the material with the covering on it, will determine whether the arrangement is satisfactory.

By using several layers of different types of blankets or sheets, it is possible to get a high absorption over a considerable range of frequencies. Some measurements made on 1-inch Fiberglas and 1/4-inch Unisorb Felt by the National Bureau of Standards, are given below. All tests were made by placing the material on the floor; on top of the blanket a perforated iron sheet was placed. The Fiberglas and Unisorb Felt were first tested separately, and then together, with the felt on top.

	128	256	512	1024	2048	4096
1-inch Fiberglas	0.20	0.66	0.92	0.93	0.83	0.88
1/4-inch Unisorb Felt	.04	.05	.14	.57	.66	.86
1-inch Fiberglas + 1/4-inch Unisorb Felt	.33	.86	.98	.97	.89	.91

While the felt is not very good at 128 and 256, it nevertheless produced a considerable increase in the coefficient when it was combined with the Fiberglas. If the coefficients of the individual layers are known, it will be seen from this example that it is not possible to predict just what the combination of the two will give. As stated before, in an accurate prediction of the noise reduction to be expected, the absorption coefficient of the actual arrangement of materials to be used should be known.

Of course, in making any choice of absorbents for aircraft, there are other properties which should be considered in addition to the absorption coefficient. The most important of these is weight. The material used should have the minimum of weight consistent with good absorption. Weight reduces the pay load, so that unnecessary weight is particularly costly. Bruderlin (reference 21) has calculated that in the 5-year life of an airplane of the DC-2 type, the net average cost per pound of excess weight is \$325, a sizable figure, especially if the excess is very much. For this reason the designer in choosing his acoustical material must restrict his attention to the very light materials. Fortunately, there is a fair-sized collection to choose from; in table IV we have compiled the known absorption data on low density materials.

While a material may have high absorption and low density, it still may not be the best one to use, since there are certain other important properties which it may lack. In selecting the proper one to use, considerations should be given to such quantities as heat conductivity, moisture absorption, fire resistance, vermin resistance, disintegration or packing under service conditions, chemical stability, etc.

Naturally, it is of considerable advantage if the product happens to be a good thermal insulator also. In this connection there is prevalent a widespread misconception to the effect that good sound absorbers always have low thermal conductivities. While this may be true in some cases, it is not necessarily so. All of the known thermal conductivities of products listed in table IV are given in table V. The thermal conductivities are given in terms of the K factor (B.t.u. per hour per square foot per degree Fahrenheit per 1 in. thickness).

Under the extremes of temperature and weather conditions which aircraft experience, the condensation of moisture on the acoustical material is very apt to occur. If the absorption of moisture takes place, there will be a considerable increase in the weight of the airplane and the acoustical efficiency of the treatment may be reduced. In addition, the thermal conductivity will be reduced. For these reasons it is important that the material be waterproof. One hundred percent waterproofness may be objectionable in certain instances, however, as S. J. Zand has pointed out to the author. If the material is placed next to the metal skin of the fuselage, say, glued on, then there will be formed slight air pockets between the skin and the back surface of the material. The water vapor originally present in these pockets will condense and if the absorbent is impervious to moisture the water cannot escape; whence the possibility of corrosion of the skin arises. If there is a slight avenue of escape left open for the water vapor - say, if the material is not entirely waterproof - the danger of corrosion will be eliminated. To assist in the evaporation process, it is quite feasible to bypass some of the air stream from the ventilating system through the space between interior trim and fuselage.

An item which should not be overlooked is the question of resistance to packing or settling. Vibration of aircraft is severe, and changes in acceleration are large and

occur rapidly, so that a material which may be all right for ordinary use may not be particularly suited for the airplane. There is the possibility that the fibers or substance from which the acoustic blanket is made may break up or subdivide. As a consequence, packing will result and some of the compartments in the blanket may be bare of fill-in spots.

C. Sound Insulation

While the sound-absorption coefficient suffices to describe the efficiency of the material as a sound absorber, the sound-transmission loss is the physical quantity which specifies its sound-insulation value, its ability to prevent the transmission of sound. Since the transmissivity, τ , represents a transmission of energy, the resistance to transmission, or opacity to sound, would be represented by $1/\tau$. The reciprocal of τ , expressed in the decibel scale is known as the transmission loss, i.e.,

$$\text{Transmission loss (in decibels)} = 10 \log_{10} \left(\frac{1}{\tau} \right) \quad (14)$$

To clarify this concept, consider this situation. There are two adjacent rooms, in one of which is located a source of sound. As a result of this, a certain sound level exists in the other room. To keep the level down, the second room is treated with a sound-absorbing material. It is desired to know the intrinsic insulation value of the wall between the two rooms. The difference in the sound level existing on the two sides of the wall, is due not only to its insulating efficiency but also to the absorption in the receiving room, so that to get the effect of the wall itself, a correction must be made for the absorption. From equation (11), we have for difference in level, greater than 20 decibels

$$10 \log_{10} \frac{E_1}{E_2} = 10 \log_{10} \left(\frac{A}{\tau S} \right) \quad (11)$$

where E_1 and E_2 are the sound energies in the source and receiving room, respectively, A is the total absorption in the receiving room, τ is the transmissivity of the wall and S is its surface area. Solving for $10 \log_{10} \frac{1}{\tau}$, we get

$$10 \log_{10} \left(\frac{1}{\tau} \right) = 10 \log_{10} \left(\frac{E_1}{E_2} \right) - 10 \log_{10} \left(\frac{A}{S} \right) \quad (15)$$

The expression $10 \log_{10} \left(\frac{1}{T} \right)$ is the transmission loss of the wall, $10 \log_{10} \left(\frac{E_1}{E_2} \right)$ is the observed decibel difference, so that $10 \log_{10} \left(\frac{A}{S} \right)$ is the correction term which corrects for the effect of absorption. Furthermore, the appearance of the surface area in the correction term is equivalent to reducing the result to that which would be gotten on a wall of unit area. Thus, if S were one unit area, there would be no correction for area, since $\log_{10} 1 = 0$. It is apparent, then, that the transmission loss is the unique physical quantity which is a property of the wall only. This makes it possible to compare the insulation value of different constructions by comparing their transmission losses.

The example outlined above is the basis of one method of determining the transmission loss of different structures. The panels are placed in an opening between two rooms, and the difference in level between the noisy and quiet side, the absorption on the quiet side, and the surface area of the panel are measured, these data sufficing to give the transmission loss. This method is in use at the National Bureau of Standards and other laboratories.

Observations made on a large number of panels of homogeneous construction have shown that the single, most important determinant of the insulation efficiency of a panel of this type is its mass. Figure 16 is a result of the work of Chrisler and Snyder (reference 24) conducted at the National Bureau of Standards (reference 33) on panels consisting of single sheets of different materials. It is to be seen that for the very light panels the average transmission loss* increases quite rapidly as the weight increases up to about 0.5 pound per square foot. From this point on, however, the curve begins to flatten and the rate of increase in insulation efficiency is much less. As a matter of fact, the curve of figure 16 can be represented on a logarithmic scale by a straight line. In figure 17, the transmission loss is plotted against the logarithm of the weight (lb./sq.ft.). This straight line has been given by Chrisler and Snyder (reference 24) and is represented by the dotted line of figure 16.

*The tests reported here were conducted in a slightly different fashion from that now in use; hence, while the figures obtained are not strictly transmission losses, they are very approximately so.

In table VI the actual measurements on the different materials are given. It is to be noticed that the transmission loss varies with frequency and that the panels are less effective at the low-frequency end. To specify the average performance of the panel, the average of the transmission losses at the three different frequency bands is given; in the future, in referring to the average transmission loss, we shall omit the word "average."

It has been found that the straight-line relationship between transmission loss and logarithm of the weight is valid for even very heavy panels. The designer is clearly at a disadvantage here. If he wishes to get good insulation he must resort to heavy structures. Fortunately, however, it is possible to get greater efficiency by resorting to the use of composite panels.

To illustrate the point, consider the case of three rooms arranged in a row in which room 2 is the center one, and rooms 1 and 3 the two extreme ones. Let us say, the separating partitions between the rooms are plywood, 0.125 inch thick. If we have a source of sound in room 1, test no. 14 tells us that there will be a reduction in level of approximately 19 decibels between rooms 1 and 2 and, furthermore, between rooms 2 and 3, there will be another approximate reduction of 19 decibels, so that room 3 is about 38 decibels quieter than room 1. This is a very considerable reduction, inasmuch as an increase of 19 decibels has been achieved merely by adding another plywood wall. Hence, one might expect that by using a double wall with an air space, the transmission loss would be much larger than for the single panel and much greater than the weight relationship for homogeneous panels would require.

In table VII is presented results on tests of two panels with an air space between them.

The last column in the table is significant; it states the gain in decibels of the double partition over the single homogeneous partition which has the same weight. For example, consider test no. 26, in which two aluminum sheets 0.025 inch thick were separated by an air space of 0.50 inch. The transmission loss was 16.1 decibels, and the weight of the panel was 0.70 pound per square foot. From figure 16 we see that a homogeneous panel of this weight would have a transmission loss of about 21 or 22 decibels, so that there has been an actual loss in insulation efficiency. In fact, not only is no. 26 less effec-

tive than a homogeneous partition of the same weight, but it is also poorer than no. 11, in which only one sheet of aluminum was used.

Thus, it will be seen that in practically all instances there is a loss instead of a gain. The effect of the air space, when the panels are very close, is to actually increase the transmission of sound. The difference between these results and our idealized situation of the three rooms is to be ascribed to the proximity of the two panels. For one thing, a good share of the vibration of the first panel is transmitted through the frame or common support on which the two are mounted; and secondly, the air space for these panels acts as a sort of elastic sheet which couples the two faces together. As the weight increases, however, the effect of the air space becomes less important, so that a gain in transmission loss is experienced as, for example, no. 32.

No. 30 is interesting as it suggests a clue as to what is to be done to remedy the situation. Insulite is a sound-absorbing material, hence, in no. 30 the sound level existing between the two partitions has been decreased with a consequent increase in insulation. What is needed then, is: 1) to absorb the sound energy present in the air space, and 2) to break the elastic tie which exists between the two walls as a result of the air space. For these reasons, various absorbent layers were placed in the air space. First, fibrous boards such as Celotex and Insulite, were tried. While there was an improvement over similar tests on the double wall with air space, the transmission loss was still 5 decibels less than that for a homogeneous panel of the same weight (test nos. 33-36, reference 33). For the low-density materials such as Balsam Wool, hair felt, and cotton, the following results were obtained (table VIII).

"The cotton, hair felt, and 1/2-inch layer of balsam wool are seen to give no improvement over a panel of equal weight. The thicker layers of balsam wool are seen to give an improvement of 5 decibels on the average." This reduction is what would be expected from a panel of more than twice the weight. Another series of panels was measured using a dry zero blanket, which is a product made of kapok and is very light, having a density of 1.14 pounds per cubic foot. The results are given in table IX.

The largest gain was experienced in panel no. 50 but

it must be ruled out in this comparative series of measurements, since it was not of the same size as the other panels. The best panels from the point of view of highest transmission loss for least weight are nos. 49 and 51, both giving a transmission loss of about 30 decibels with a weight of 1 pound per square foot. No. 51, however, has the disadvantage of having a highly reflecting interior surface, so that very little sound absorption will occur in the cabin. In general, the dry zero causes a net increase of 5 decibels, which is about the same as experienced with balsam wool, the dry zero panels, however, being usually lighter. Two other important points should be noticed. If the dry zero is compacted, as in no. 53, the reduction will be reduced as there is then a more solid tie between the two surfaces, the packed-in material acting to communicate the vibration from the front surface to the rear surface. In the two lightest panels, nos. 44 and 45, the dry zero is not as effective as in the heavier panels. However, if panel 44 be compared with 22, there is an increase of 9 decibels.

The results presented in table IX are, in general, in accord with a theory of Meyer (reference 7) on multiple partitions. This theory is of interest to us as it points out the limitations and possibilities in the use of this type of construction. It will be briefly summarized here.

Each partition with its accompanying air space (or absorbent-filled space) is considered as one of the iterated elements of an acoustical-mechanical system which may be represented by an analogous electrical circuit for which the mathematical solution is known. At low frequencies, such a combination has a small transmission loss. However, there exists a certain frequency (the "high-frequency cut-off") given by

$$f_c = \frac{576}{\sqrt{m l}} \quad (16)$$

where

f_c is cut-off frequency in cycles per second.

m , mass per unit area of one wall in g/cm^2 .

l , spatial separation between two successive partitions.

for which the transmission loss rises rapidly.

Figure 18 (reference 7) shows some results obtained on a) a 15-sheet cellophane wall with an air space of 1-centimeter and b) a wall consisting of 3, 5, and 10 sheets of roofing paper with $l = 2$ centimeters. The cellophane is so light that the cut-off frequency is 6,700 cycles; a noticeable rise in the curve is evident at this frequency. For the roofing paper, f_c is reduced to 800 cycles per second because of the increased weight and air space. It will be noticed that all of the b curves start to rise in the vicinity of 800 cycles per second; furthermore, for frequencies below this frequency the threefold, fivefold, and tenfold wall give about the same results for the transmission loss. It is only for frequencies above f_c that the curves separate. Some other data of Meyer (fig. 6 of reference 7) on partitions having one, two, three, four, and five layers of plywood, show the same effect - no difference for frequencies less than f_c , with a considerable spreading for frequencies greater than f_c .

Hence, to make an effective double wall, the mass should be as large as possible and the air space should be large. This will make the cut-off frequency low and hence the transmission loss versus frequency curve will rise sharply. In the light-weight partitions measured at the NBS, f_c was relatively high. Thus, as an example, for panel 27 consisting of two aluminum sheets with an air space of 1.75 inches, f_c was 780 cycles. Since the highest frequency at which the measurements were taken was about 1,000 cycles, the value at 1,000 would not be much different from the other two measurements. In panel 32, $f_c = 680$; the transmission loss at 1,000 is considerably greater than that at the other two frequencies.

The effect of the sound-absorbing filler is to absorb sound waves which travel to and fro in the enclosure parallel to the wall surface. If this is so, it should not be necessary to fill the entire space with absorbent, but placement around the boundary should be sufficient. This was done on the multiple plywood wall with a result similar to that obtained with the air space, except that the curves arose much more steeply for frequencies greater than the cut-off. Furthermore, comparison between the results obtained on a multiple wall with three plywood sheets when the whole enclosure was filled with cotton waste and when only the boundaries were lined, showed that they had practically the same transmission loss. Figure 19 shows the effect of the introduction of the cotton on the boundary as compared to the empty air space.

The fact that it is possible to get such a sizable increase in insulation efficiency merely by placement of material around the edges should be of considerable advantage in reducing the weight requirement for soundproofing cabins. The author is not aware of the application of this principle to airplane insulation.

Most of the insulation schemes now in use may differ somewhat from those particular constructions listed in tables VI, VII, VIII, and IX; however, these tables are useful in estimating the approximate value of any contemplated partition by comparison of the desired construction with a similar panel listed in the tables. This is a risky procedure sometimes so that it is always advisable to get the transmission loss by direct measurement of a sample partition.

Several investigators make use of a method which will give the relative values of different partitions. In general, this scheme consists in placing the partition between two small enclosures. The difference in level which is observed is taken as the insulation efficiency of the partition. D. P. Loye (reference 28) of the Electrical Research Products, Inc., of Hollywood, California, reports a number of such relative measurements. H. Bruderlin of the Douglas Aircraft Company, of Santa Monica, California, has a method in which the source room is a 2-foot cube. Phonograph records of airplane noise are used for a sound source, so that the over-all noise reduction is obtained. In a private communication to the author, Bruderlin states that over 300 variations of airplane partitions have been compared in this way. For purposes of standardization, a panel having a known transmission loss should be measured so that all data may be referred to it. F. K. Teichmann (reference 29) has measured various felts in this way by using a rectangular box of two equal compartments. The opening used was about 21 square inches.

Arbitrary measurements of this nature are fraught with difficulties in the interpretation of the results. For one thing, the absorption of the panel face is not separated from the transmission loss characteristic of the panel. In addition, if the size of the panel is small it may be much stiffer than the fairly large-size unit typical of an actual construction. For a small-size panel, the way in which the edges are clamped sometimes makes quite a difference. Sound-pressure measurements made close to the panel may be deceiving because of the stand-

ing wave system existing at its face. If the two halves of the box in which the measurements are made are not isolated from each other, there may be more sound transmitted through the box walls than through the panel, especially if the former are not heavy. To establish whether the arbitrary method places different panels in the same relative order as the absolute method, several panels, say three or four, whose absolute transmission losses are known, should be compared by the relative method. This will give an insight into the reliability of the results so obtained.

To give the reader some idea of current practice in the soundproofing of aircraft, table X is given. This table has been taken from a report (reference 35) on the physical properties (from the textile technologist's viewpoint) of the various insulating materials; the report was prepared by the engineering section of the Air Corps at Wright Field.

Data on the transmission loss and absorption coefficient of the various soundproofing arrangements listed in table X have not been found in the literature.

D. Soundproofing Procedures

In predicting the noise reduction to be expected from any given treatment, we must, then, have a knowledge of the two quantities α and τ . However, since these two quantities vary with frequency, the question arises as to what frequency should be considered typical - how should the coefficients be averaged? To answer this question, it is necessary to have a frequency analysis of the noise of the airplane. If the energy is fairly well distributed among the different frequencies, then the average transmission loss and the average absorption coefficient will suffice. If the noise predominates at certain frequencies, then an average over the dominant frequencies will give good results. As an illustration, we quote Zand's figures on the Douglas DC-1 (reference 31), in which the energy between 64 and 512 cycles is 10 decibels above the energy between 512 and 8,192. To get the noise reduction, we use equation (11):

$$\text{Noise reduction} = 10 \log_{10} \frac{\text{Absorption}}{\text{transmittance}}$$

The absorption coefficient was taken at the predominant frequency. Table XI gives these data.

This predicted reduction agreed with the actual reduction to within 3 decibels. For purposes of calculating the contribution of passengers and chairs, a figure of 3 to 4 units of absorption per seated passenger may be used (reference 9). This figure includes the absorption of the chair.

From the calculation above, we may illustrate the very important effect of an opening or highly transmitting surface, such as an open window. As an example, suppose a window is partially open, so that 1 square foot is exposed. The transmissivity of an open window is unity, so that the total transmittance is increased from $T = 0.835$ to 1.835.

$$\text{Noise reduction} = 10 \log_{10} \frac{590}{1.835} = 25.1 \text{ decibels}$$

That is, 1 square foot of open surface in 860 will cause a reduction in efficiency of a little more than 3 decibels. If there are small openings in the cabin, leaks, ventilating system ports, etc., their combined area may be readily equivalent to the effect of 1 square foot.

The influence of a small opening is dependent on the ratio of the size of the opening to the total transmitting surface, and on the transmissivity of the walls. It may be shown (p. 52, reference 38) that if the opening has an area s , the panel an area S , and the transmissivity of the panel is τ , the noise reduction will be decreased by $10 \log_{10} \left(1 + \frac{S}{s} \frac{1}{\tau} \right)$ decibels. Thus, if $s/S = \tau$, the reduction will be decreased by 3 decibels. Using 3 decibels as the maximum diminution in level which is permissible, we can say that for a cabin which has a 20-, 30-, 40-decibel transmission loss, the ratio of the total area of openings to the total cabin surface should not be greater than 0.01, 0.001, 0.0001, respectively.

Davis (reference 26) has calculated the noise levels to be expected within cabins of various airplanes on the basis of the theory outlined here. Usually his calculated values agreed with the observed values to within 2 decibels, although some results differed by as much as 5 decibels.

If the noise spectrum of the airplane is known, it is possible then to predict the level within the airplane. However, in the event of lack of this information, a frequency analysis should be taken. Figure 20 (reference 30) shows a frequency analysis of the German Focke-Wulf air-

plane F.W.-200, before and after treatment (curves 1 and 2) and the treated Neubau Ju-52 airplane (curve 3). It will be seen that the noise predominates at the lowest frequencies and that the treatment (on the F.W.-200) is more effective at the high frequencies. It will be noticed that the noise reduction varies from about 15 decibels at the low frequency end to about 30 decibels at the high end. Furthermore, reference to the loudness contours of the ear (fig. 2) shows that the loudness level which the ear experiences for these various frequencies is very close to the noise-level curve given here. This is because at these high levels of about 100 decibels, the ear responds about equally to all frequencies. Thus the low-pitched notes contribute heavily to the loudness.

Zand (reference 32) describes a method in which the bare airplane is first flown; a series of vibration amplitude measurements is taken at various parts of the airplane. Upon landing, particularly bad panels having considerable vibratory motion are reinforced with bracing. In the particular airplane cited in Zand's paper, this treatment resulted in a 3-decibel decrease in level for an expenditure of 4.4 pounds.

The airplane was divided into 36 stations, at each of which noise-level readings were taken, and at three of the stations a frequency analysis of the noise was made. This latter showed that the predominant noise existed at the fundamental frequency of the exhaust ($\frac{14 \times 2100}{2 \times 60} = 163$ cycles, 14-cylinder engine running at 2,100 r.p.m.) and of the propeller ($\frac{3 \times 2100}{60} \times \frac{2}{3} = 70$ cycles, three-blade propeller with gearing). It was found both in the vibration and sound measurements that the vibration amplitude and noise level were maximum in the front of the cabin, minimum in the middle region of the cabin, and average at the rear. These three sections were treated differently; section A, the noisiest section, was treated with material which was glued onto the skin and is a very good vibration damper; section B, of minimum noise level, was treated with a similar but lighter vibration absorber which is sufficient to damp light vibrations; and section C, of average vibration level, was treated with a similar material of intermediate properties. The materials used were kapok with a large percentage of paper pulp in it. This treatment produced a reduction of 6 decibels.

For the reduction of noise an intermediate layer of kapok was installed. This layer was installed so as to "float" in the air space between the first layer and the cabin trim. For the position of maximum noise, three layers of kapok were used, average noise two layers, minimum noise one layer. Adjusting the treatment to the intensity level has several advantages: It makes the level uniform throughout the cabin, so that there are no favorite seats; it involves a saving in weight as the weight is distributed where it will do most good.

After this treatment the noise level was again measured and a frequency analysis made, showing that the high-frequency component had been fairly uniformly attenuated. In different parts of the cabin, however, the low-frequency components were still troublesome. To secure low-frequency absorption, a stretched membrane of doped airplane fabric was used for the cabin trim and was backed by a damping layer of felt. The degree of stretch may be controlled to give a maximum absorption coefficient at different frequencies. Thus, for section A, an absorption coefficient of 55 percent was obtained at 64 cycles, for section B 70 percent at 256, and for section C 50 percent at 128. The noise levels were then measured again; the average reduction with this completed treatment was 24 decibels and the airplane was quite comfortable.

Figure 21 is taken from Zand's paper and shows the levels at different positions after the various treatments. The sound levels given are with a reference level of 1 millibar root-mean-square sound pressure; to convert to the standard reference level, approximately 14 decibels should be added. The actual average noise level in the airplane was 83 decibels above a reference level of 10^{-16} watts per square centimeter. When loudness level measurements were taken, the level was 79 phons. In figure 22 the progress of the noise reduction at different frequencies and at different steps in the procedure, is indicated.

Spain, Loye, and Templin (reference 28) describe a method in which a continuous record of the sound level at various frequencies is obtained. In this method a high-speed sound-level recorder in conjunction with a continuously variable frequency analyzer is used. The frequency analyzer is arranged so that it passes all the frequencies within a 200-cycle band, with the frequency marked on the scale as the center of the band. A motor drive is arranged on the analyzer so that this center point is continuously

varied. The sound level at the various frequencies is recorded on waxed paper by the recorder. An adjustment is provided to change the band width to 20 cycles. When the record is taken with the 20-cycle-band width, the various harmonic components of the engine explosion, crankshaft, and propeller noise show up. This gives very valuable information as to the relative values of different components in different parts of the airplane. For example, in the pilot's compartment of one airplane, the fundamental of the propeller plus the second harmonic of the crankshaft are dominant to the extent of being 30 decibels above any other frequencies, while in the cabin the importance of these two components is very much diminished. Figure 23 shows a typical record taken in this way.

By using a vibration pick-up in conjunction with this apparatus, a continuous record of the relative amplitude at different frequencies may be obtained. A frequency analysis of the fuselage vibration can then be taken in both the pilot's and passengers' compartments so that the effect of proximity to propeller or engine noise may be studied. Such a study of noise and vibration will give an insight into the relative amount of noise which arises from structure-borne vibration and that which arises from air-borne sound.

Different sections of the fuselage may radiate sound in different amounts so that certain surfaces radiate an inordinate amount of sound. It is desirable to be able to measure the contribution from a given area irrespective of the sound produced by an adjacent area. To accomplish this, Spain, Loye, and Templin (reference 28) provide the microphone with a special attachment, as a result of which the sound-radiation characteristic of a limited area only is measured. The results of such a noise survey showed that the ceiling radiated less on the average, the surfaces below windows were 9 decibels above the average, etc. Hence, the material could be distributed most effectively in accordance with these experimental findings.

To carry the noise analysis to its logical conclusion, it is necessary to know which of the three major noise sources - the propeller, engine, or aerodynamic disturbances - contributes the most energy. The above authors indicate a procedure which suffices to separate the total noise into these three components. With the aid of this analysis figure 24 was obtained for an airplane with a three-blade geared propeller. It shows that, in this case,

the propeller noise was below both engine noise and aerodynamic noise. For a direct-driven propeller, the propeller noise predominated. On another airplane with a lower tip speed and a stiffer engine mounting, the engine noise was greatest. The latter type of airplane, when fitted with a two-blade direct-driven propeller, showed that for low r.p.m., the engine noise was loudest, but for 1,800 r.p.m., the propeller noise was dominant.

As the principles and experimental knowledge enunciated in the foregoing became better known, it was natural that increased riding comfort continued to be secured with decreasing expenditure of weight. Diminishing noise level and weight allowance per passenger went hand in hand. Figure 25 shows the result of Zand's (reference 32) soundproofing work on airplanes. In the Wibault 670 the noise level is approximately 79 decibels (above 10^{-16} watts per sq. cm), the expenditure of weight per passenger only about 12 pounds. The weight of soundproofing ranges from about 2 percent for smaller airplanes to 1 percent for very large airplanes. In the Douglas DST (reference 22), an airplane of 24,000 pounds, the weight of treatment was 204 pounds, only 0.85 percent of the total weight; the sound level was 79 decibels. All of the published literature indicates that the figure of 79 decibels and weight treatment of about 12 pounds per passenger is very close to a figure which would seem to be difficult to better. Bruderlin (reference 22) predicted a noise level of 77 decibels for the Douglas DC-4 at 65-percent power; the actual level obtained is not known to the author. The German Focke-Wulf F.W.-200 airplane (reference 30) used only 7.7 pounds of soundproofing per passenger but the sound level would seem to be about 82 decibels. As we have stated before, the current practice with most manufacturers is for the sound level in the cabin to range from 83 to 91 decibels (reference 35).

The possibility of still further reducing the weight allowance would seem to hinge on the potential application of the theory of Meyer which we have already discussed (p. 43). Meyer's research indicates that, in the usual soundproofing construction in which sound-absorbing material is placed between fuselage and cabin trim, it should be necessary to distribute the material at intervals only. A continuous distribution of material would not seem to be necessary. The applicability of this scheme to aircraft needs further investigation.

While we have devoted our chief attention to discussing the attainment of quiet in the cabin, it is evident that the pilot's compartment should not be neglected. The air-line pilot who is subjected to unending noise daily, is bound to suffer fatigue and a loss of efficiency. In commercial transport airplanes the noise level in the pilot's quarters varies from 85 to 102 decibels, which is indicative of the trend toward quiet cockpits.

The author is indebted to V. L. Chrisler and P. R. Hoyl for many valuable suggestions and criticisms of this paper, and to S. J. Zand, who provided considerable useful information.

National Bureau of Standards,

Washington, D. C., December 9, 1939.

BIBLIOGRAPHY*

I. ACOUSTICS

A. Hearing

1. Davis, A. H.: An Objective-Noise Meter for the Measurement of Moderate and Loud, Steady and Impulsive Noises. Jour. Inst. of Elect. Eng., 83, 249 (1938).
2. Fletcher, Harvey, and Munson, W. A.: Loudness, Its Definition, Measurement, and Calculation. Jour. Acoustical Soc. Am., 5, 82 (1933).
3. Fletcher, Harvey, and Munson, W. A.: Relation between Loudness and Masking. Jour. Acoustical Soc. Am., 9, 1 (1937).
4. Laird and Coye: Psychological Measurements of Annoyance as Related to Pitch and Loudness. Jour. Acoustical Soc. Am., 1, 158 (1929).
5. Meister, F. I.: Physiological Evaluation of Shock Measurements. Akustische Zeits., 1, 1 (1937). Also see summary in English in Jour. Acoustical Soc. Am., 9, 53 (1937).

B. General

6. Heyl, Paul R., and Chrisler, V. L.: Architectural Acoustics. Cir. National Bureau of Standards (1938) C418.
7. Meyer, E.: Die Mehrfachwand als akustisch-mechanische Drosselkette. Elektrische Nachrichten-Technik, 12, 393 (1935); Z. f. Tech. Phys., 16, 565 (1935).
8. Meyer, E.: "Über das Schallschluckvermögen Schwingungsfähiger nicht-poröser Stoffe, Elektrische Nachrichten-Technik, 13, 95 (1936)
9. Sound Absorption Coefficients of the More Common Acoustic Materials. Letter Cir. National Bureau of Standards (1938) LC-639.

* Only those references have been numbered which are referred to in the text; the others have been included for the sake of completeness.

II. AIRCRAFT NOISE AND ITS REDUCTION

A. Propeller Noise

10. Deming, A. F.: Noise from Propellers with Symmetrical Sections at Zero Blade Angle, I. T.N. No. 605, N.A.C.A., 1937.

Deming, A. F.: Noise from Propellers with Symmetrical Sections at Zero Blade Angle, II. T.N. No. 679, N.A.C.A., 1938.
11. Ernsthausen, W.: The Source of Propeller Noise. T.M. No. 825, N.A.C.A., 1937.
12. Ernsthausen, W.: Investigation on the Noise of Aircraft Propellers. Akustische Zeits. 3, 141 (1938).
13. Gutin, L.: ^UÜber das Schallfeld einer Rotierenden Luftschraube. Phys. Zeits. der Sowjetunion, 9, 57 (1936).
14. Hilton, W. F.: The Photography of Airscrew Sound Waves. Roy. Soc. Proc., 169A, 174 (1938).
15. Kemp, C. F. B.: Intensity of Low Frequency Sounds Close to a Metal Airscrew. Phys. Soc. Proc., 45, 727 (1933).

Munk, M. M.: Silencing of Propellers by Thrust Relief. Aero Digest, 33, no. 67 (1938).
16. Obata, Juichi; Yosida, Yahei; and Morita, Sakae: Studies on the Sounds Emitted by Revolving Airscrews. Aero. Res. Inst., Tokyo Imperial Univ., Parts I and II, 6, nos. 13 and 14, Reports Nos. 79 and 80.
17. Obata, Juichi; Yosida, Yahei; and Yosida, Umezirô: Investigations on the Origin of the Sound Emitted by Revolving Airscrews. Aero. Res. Inst., Tokyo Imperial Univ., 10, no. 14 (1935). Report No. 99.
18. Obata, Juichi; Yosida, Yahei; and Yosida, Umezirô: On the Directional Properties of Airscrew Sound. Aero. Res. Inst., Tokyo Imperial Univ., 11, no. 2 (1936). Report No. 134.

19. Obata, Juichi, Kawada, Sandi, Yosida, Yabei, and Yosida, Umezirô: On the Relation between the Performance and the Loudness of Sound of an Airscrew. Aero. Res. Inst., Tokyo Imperial Univ., 11, no. 9 (1933), Report No. 141.
20. Stowell, E. Z., and Deming, A. F.: Noise from Two-Blade Propellers. T.R. No. 526, N.A.C.A., 1935.

B. Airplane Quieting

- Bassett, P. R., and Zand, S. J.: Noise Reduction in Cabin Airplanes. A.S.M.E. Trans., 56, 49 (1934).
- Bassett, P. R.: Passenger Comfort in Air Transportation. Jour. Aero. Sci., Feb. 1935.
21. Bruderlin, H. H.: Developments in Aircraft Sound Control. Jour. Acoustical Soc. of Am., 8, 181 (1937).
22. Bruderlin, H. H.: "Like a Kitten" in Sound-Proofed Sleepers. Aviation, 36, 22 Mar. (1937).
23. Capon, R. S.: The Reduction of Aircraft Noises. Engineering, 136, 475 and 503 (1933).
24. Chrisler, V. L., and Snyder, W. F.: Soundproofing of Airplane Cabins. Jour. Res. National Bureau of Standards, 2, 897 (1929).
- Davis, A. H.: The Cause of Noise in Aircraft. Aircraft Engineering 2, 273 (1930).
25. Davis, A. H.: Noise. Roy. Aero. Soc., 35, 676 (1931).
- Davis, A. H.: Noise. Aeroplane, 40, 725 (1931);
Flight 23, 391 (1931); Mech. Eng., 53, 750 (1931).
- Davis, A. H.: Silencing Aircraft. Engineer, 156, 316 (1933).
26. Davis, A. H.: Silencing of Aeroplanes. Aircraft Engineering, 5, 290 (1933).
- Davis, A. H.: Silencing Air Liner Cabins. Airways and Airports, 10, 265 (1933).
- Denton, J.: L'alutte contre le bruit dans les avions. L'Aéronautique, 16, 5 Jan. (1934).
- Dryden, H. L.: Silencing the Airplane. Experiments and investigations by aeronautics branch of the Dept. of Commerce. A.S.M.E. Trans., 2, 107-111 July-Sept. (1930).

- Dryden, H. L.: Quieting the Airplane Cabin. Commercial Standards Monthly, 7, 75 (1930).
- Geisse, J. H.: The Roads to Noiseless Flight. Western Flying, 8, 42 Nov. (1930).
27. Golding, P.: Heating and Ventilating Airplanes without Noise. Heating and Ventilating, 30, 37 (1933).
- Gutsche, F.: Der Flugzeuglaerm und seine Bekaempfung. Z.V.D.I., 78, 825 (1934).
- Metral, A.: Un aspect particulier de la lutte contre la bruit. L'insonorisation des avions, Génie Civil, 109, 79 and 97 (1936).
- Miller, R. A.: Glazing Problems in Aircraft Cabins. Aero Digest, 29, 22, Sept. (1936).
- Nutt, A. E. W.: Aircraft Noise - Its Measurement and Suppression. Roy. Air Force Quarterly, 4, 35 (1933).
- Sayers, W. H.: Noise Elimination. Aeroplane, 35, 533 (1938).
28. Spain, C. J., Loye, D. P., and Templin, E. W.: Reduction of Airplane Noise and Vibration. A.S.M.E. Trans., 58, 423 (1936).
29. Teichmann, F. K.: Uses of Felt in Aircraft Construction. Aero Digest, 24, 36, Feb. (1934).
- Tucker, W. S.: The Problem of Noise in Civil Aircraft and the Possibilities of Its Elimination. Roy. Aero. Soc. Jour., 32, 185 (1928); T.M. Nos. 473, Parts I and II, N.A.C.A., 1928.
- Verticchio, D.: Il rumore nei velivoli. Rivista Aeronautica, 11, 242 (1935).
30. Wehner, H., and Willms, W.: Die Erfolge der Entlär-^ung in Flugzeugkabinen. Luftwissen, 5, 121 (1938).
- Zand, S. J.: A Study of Instrument Board Vibrations. S.A.E. Jour., p. 263, Oct. (1931).
- Zand, S. J.: The Decibel. Aviation Engineering, 8, 19 Feb. (1933).

- Zand, S. J.: Quiet within the Airplane. *Aviation*, 32, 106 (1933).
- Zand, S. J.: Douglas - The Silent Transport. *Western Flying*, 13, 52 (1933).
31. Zand, S. J.: Acoustics and the Airplane. *A.S.M.E. Trans.*, Feb. 1934, p. 49.
- Zand, S. J.: Deducing Decibels. *Aeroplane*, 49, 689 (1935).
32. Zand, S. J.: Comfort in Air Travel. *Roy. Aero. Soc.*, 40, 524 (1936).
- Zand, S. J., and Perot, G.: Etude du confort à bord des avions de transport et application pratique à un appareil. *L'Aeronautique*, 18, 69 (1936).
33. Reduction of Airplane Noise. U.S. Dept. of Commerce, *Aero. Bul. no. 25*, Oct. 1930.
34. Reports of Tests on Reduction of Airplane Noise by Use of Mufflers. U.S. Dept. of Commerce, *Air Commerce Bul.*, 4, no. 12, Dec. 1932.
- Silence Within. *Flight*, 29, 348 (1936).
- Silencers. *Flight*, 21, 1261 (1929).
35. Sound and Heat Insulating Materials. *Eng. Sec. Memo. Report M56-3167*, U. S. Air Corps, Wright Field.
- The Sounds of Airplanes. *Aircraft Engineering*, 2, 17 (1930).
- Stinson Reliant for 1937. *Aero Digest*, 30, 60, Feb. 1937.

III. BOOKS

36. Davis, A. H.: *Modern Acoustics*. G. Bell and Sons, Ltd., 1934.
37. Knudsen, V. O.: *Architectural Acoustics*. John Wiley and Sons, Inc., 1932.
38. Schoch, A.: *Die Physikalischen und technischen Grundlagen der Schalldämmung in Bauwesen*. S. Hirzel, Leipzig, 1937.
- Stevens, S. S., and Davis, H.: *Hearing*. John Wiley and Sons, Inc., 1938.

TABLE I. Noise and "Comfort" Level of Different Vehicles at Various Speeds

Year	Vehicle	Speed m.p.h.	Noise level at this speed, decibels	Maximum speed speed	Noise level at maximum speed, decibels	Comfort level at maximum speed	Conver- sation level
1935	2-engine bomber	230	124	250	129	A ¹	a ¹
1929	3-engine 12- passenger transport	110	119	125	129	A	a
1928	2-engine 6- passenger transport	105	117	120	114	A	a
1927	4-engine 30- passenger transport	75	94	95	99	C	c
1934	Railway car	100	104	110	109	B	c
1933	Railway car	85	96	95	101	C	c
1918	N.Y. subway	50	104	65	114	A	b
1925	U.S. Pullman sleeper	55	82	80	94	C	d
1930	6-cylinder passenger car	40	74	70	90	D	d
1933	8-cylinder de luxe passen- ger car	40	72	70	94	C	d
1933	V-16 passenger car	40	68	55	79	E	e
1934	V-12 passenger car	40	70	90	84	E	e
1929	Ocean motorboat cabin class	23	49	30	69	F	f

¹Comfort level: A - very painful, B - very uncomfortable, C - uncomfortable, D - slightly uncomfortable, E - comfortable, F - very comfortable.

Conversation level: a - impossible to converse even by shouting, b - possible by shouting, c - possible with effort up to 5 ft., d - possible with slight effort up to about 8 ft., e - normal conversation up to about 15 ft., f - conversation in low tones possible.

TABLE IV
Absorption Coefficients of Light-Weight Acoustical Materials¹

Name	Thick- ness (in.)	Weight (lb./sq. ft.)	Coefficient of frequencies of						Authority	Mount- ing	Manufacturer
			128	256	512	1024	2048	4096			
Akoustikos felt	1/2	0.37	0.10	0.14	0.27	0.48	0.74	0.62	NBS*	A	Johns-Manville, New York, N. Y.
Balsam Wool (scrim facing)	1	.29	.18	.36	.55	.65	.67	.66	NBS	A	Wood Conversion Co., Chicago, Ill.
Balsam Wool	2	.52	.23	.40	.58	.69	.70	.66	V. O. Knudsen	-	"
Cabot's Quilt	-	.41	.12	.30	.69	.82	.41	.31	NBS	A	Samuel Cabot, Inc., Boston, Mass.
Cellufoam type HD	{ 1	.14	.11	.28	.60	.70	.73	.78	NBS	B	Cellufoam Corp., Chicago, Ill.
Corning Glass Mineral Wool Blanket	1	.14	.14	.33	.58	.82	.82	.82	NBS	C	"
Dry Zero in burliap	2	.44	.27	.63	.75	.75	.75	.75	NBS	A	Corning Glass Co., Corning, N. Y.
Dry Zero in Muslin	2	.50	.22	.35	.61	.80	.91	.98	NBS	A	Dry Zero Corporation, Chicago, Ill.
Dry Zero in plicofilm	1	.21	.10	.21	.38	.56	.60	.60	S. J. Zand	A	"
Fiberglas	3	.72 ²	.50	.99	.97	.85	.87	.88	NBS	D	Gustlin Bacon Co., Kansas City, Mo.
Firtex	1/2	.43	.10	.34	.73	.83	.70	.66	NBS	C	Dant & Russell, Inc., Portland, Ore.
Glass Wool	1	.34	.20	.66	.92	.93	.83	.88	NBS	B	Owens Illinois Glass Co., Toledo, Ohio.
Insulite	1/2	.41	.07	.20	.53	.77	.74	.74	NBS	D	Insulite Co., Minneapolis, Minn.
Johns-Manville BX-4	1	.39	.10	.34	.70	.81	.78	.71	NBS	A	"
Acoustic Blanket BX-4M	2	.62	.22	.73	.92	.94	.83	.83	NBS	A	Johns-Manville, New York, N. Y.
"K" Felt	3/16	.08	.16	.21	.30	.53	.58	-	-	-	-
	4/16	.11	.17	.24	.40	.65	.74	-	Bares	-	American Felt Co., New York, N. Y.
	5/16	.14	.18	.27	.45	.70	.77	-	Knobel	-	-
	6/16	.17	.19	.29	.51	.75	.80	-	& Young	-	-
	8/16	.22	.20	.31	.62	.81	.83	-	-	-	-
Kapok (Prime Java)	2	.53	.30	.43	.58	.64	.85	.90	S. J. Zand	E	Seaman Paper Co., Chicago, Ill.
Kwikto	1	.083	.08	.19	.70	.98	.86	.69	Riverbank	B	U. S. Gypsum Co., Chicago, Ill.
Quietone	1/2	.47	.10	.22	.56	.69	.63	.63	NBS	E	Seaman Paper Co.
C. S. Seapak	1/4	.11	.33	.36	.74	.74	.73	-	Riverbank	E	"
C. J. Seapak	1/4	.11	.39	.31	.76	.74	.75	-	Riverbank	E	"
C. J. Seapak	1/2	.22	.19	.23	.99	.62	.61	-	Riverbank	F	"
Stonefelt type A	1/2	.24	.11	.29	.88	.65	.31	-	Johns-	-	Johns-Manville, New York, N. Y.
	3/4	.31	.12	.35	.91	.70	.29	-	Manville	-	"
	1	.37	.15	.52	.98	.60	.27	-	Laborato-	-	"
Stonefelt type M	1-1/2	.43	.26	.74	.95	.41	.23	-	ries	-	"
	1/2	.17	.08	.18	.54	.78	.80	-	-	-	"
	3/4	.23	.09	.22	.65	.80	.85	-	-	-	"
	1	.29	.10	.28	.76	.85	.85	-	-	-	"
4 1/2-inch Stonefelt type M	1-1/2	.36	.22	.57	.97	.91	.78	-	-	-	"
5 1/2-inch Stonefelt type M	1/2	-	.18	.58	.83	.56	.38	-	-	-	"
1 1/2	1	-	.22	.64	.77	.66	.61	-	-	-	"
Tropal	1	.17	.29	.48	.70	.83	.90	-	Perrot	-	Airpak, Ltd., London, England.

¹As a general rule, coefficients have been given only for those thicknesses for which the weight is less than 0.5 lb. to the square foot. There are some exceptions. Practically all of the materials included in the table are marketed in blanket form. The only exceptions are Cellufoam, Firtex, and Quietone, which are acoustic boards. The measurements from different laboratories are not strictly comparable as the test conditions may be different and in some cases the reverberation-room method may not have been used. In making a choice of material on the basis of these coefficients, it follows that slight differences should be neglected. It is difficult to give an accurate statement of the degree of reliability of the various measurements.

²Nominal density.
³Mountings: A. Laid on floor. B. Cemented to Gypsum wallboard. C. Nailed to furring strips, 13/16- by 2-inch strips.
 D. Covered with highly perforated sheet iron. E. Placed loosely on 1- by 2-inch furring strips. F. Cemented to 22-gage metal and placed on floor.
⁴Two layers C. J. Seapak, crossed corrugations.
⁵In contact with doped fabric interior trim.
⁶With broadcloth as interior trim.
 *National Bureau of Standards.

TABLE V

Thermal Conductivity of Light-Weight Acoustical Materials

Name	Density (lb./cu.ft.)	k	Mean temper- ature °F.	Authority
Balsam Wool	2.2	0.27	90	NBS
Caoot's Quilt	{ 3.4 4.6	{ .25 .26	{ 90 90	NBS
Cellufoam	1.73	.29	109	NBS
Dry Zero Blanket	1.9	.23	-	J. C. Peebles
Firtex	14.4	0.28 to 0.31	-	V. O. Knudsen
Glass Wool	1.78	.35	81	NBS
Glass Wool	1.50	.27	75	J. C. Peebles
Insulite	12.0	.30	-	V. O. Knudsen
"K" felt	5.3	.21	-	J. C. Peebles
Kapok between burlap	1.0	.24	-	NBS
Kwilko	1.0	.24	-	J. C. Peebles
Seapak	5.1	.26	-	J. C. Peebles
Stonefelt	2.7-3.0	.25	60	Johns-Manville
Tropal	3.0	.23	-	National Physical Laboratory

TABLE VI

Single Panels of Homogeneous Materials

Material	Thick- ness (in.)	Weight (lb./ sq. ft.)	Transmission loss in decibels at frequency bands of -			Average
			150-220	400-470	1000-1120	
1 Wrapping paper	0.006	0.017	1.6	1.8	2.3	1.9
2 Aluminum	.006	.075	5.5	6.6	8.3	6.8
3 Airplane fabric ¹		.10	5.3	6.7	11.2	7.7
4 Balsa wood ² ₃	.25	.16	10.9	10.5	12.6	11.3
5 Balsam wool ²	.50	.20	7.4	9.5	9.5	8.8
6 Micarta ²	.047	.23	12.4	12.8	15.7	13.6
7 Alclad		.30	9.6	15.8	16.9	14.1
8 Balsa wood ²	.50	.30	11.5	14.5	14.3	13.4
9 Duraluminum ₃	.020	.33	16.6	16.4	16.1	16.4
10 Balsam wool ³	1.00	.33	9.8	11.2	16.4	12.5
11 Aluminum	.025	.35	16.1	17.3	20.3	17.9
12 Insulite	.25	.36	20.9	16.3	20.3	19.2
13 Insulite	.31	.43	14.8	16.7	22.0	17.8
14 Plywood	.125	.52	17.5	18.7	21.8	19.3
15 Celotex	.44	.63	17.1	20.3	24.0	20.5
16 Plywood	.25	.73	18.6	20.8	24.5	21.3
17 Insulite	.50	.75	21.4	23.3	25.0	23.2
18 Galvanized iron	.03	1.2	24.5	25.7	26.6	25.5
19 Double strength glass	.13	1.6	24.7	27.0	32.0	27.9
20 Duplate glass ²	.094	1.8	25.3	28.6	30.8	28.6
21 Plate glass	.25	3.65	28.7	32.0	34.2	31.6

¹Doped five times, varnished twice.

²For these materials the frequency bands were 150-180, 400-440, and 1000-1093 cycles per second.

³Paper each side.

TABLE VII
Two Panels with Air Space

	Front panel Material	Thick-ness (in.)	Rear panel Material	Thick-ness (in.)	Air space (in.)	Weight (lb./sq.ft.)	Transmission loss in decibels at frequency bands of			Aver- age	Gain
							150-220	400-470	1000-1120		
22	Airplane, fabric doped ¹	-	Imitation leather	-	1.75	0.28	9.8	10.2	13.2	11.1	-3
23	do. ¹	-	Micarta	0.047	1.75	.33	10.0	11.7	14.5	12.1	-4
24	Aluminum ¹	0.025	Imitation leather	-	1.75	.53	13.0	15.1	19.3	15.8	-4
25	do. ¹	.025	Micarta	.047	1.75	.58	15.0	16.2	21.8	17.7	-2
26	do.	.025	Aluminum	.025	.50	.70	14.5	15.1	18.6	16.1	-5
27	do.	.025	do.	.025	1.75	.70	13.2	15.5	15.0	14.6	-7
28	do. ¹	.025	Plymetal	-	1.75	.81	18.5	18.2	23.9	20.2	-1
29	Plywood	.125	Plywood	.125	1.75	1.04	19.9	18.8	26.5	21.7	-3
30	Insulite	.50	Insulite	.50	1.75	1.5	26.2	29.0	37.6	30.9	4
31	do.	.50	do.	.50	0	1.5	24.0	25.8	29.7	26.5	-1
32	Double-strength glass	.125	Double-strength glass	.125	.50	3.2	29.1	27.5	42.8	33.1	2

¹For these materials the frequency bands were 150-180, 400-440, and 1000-1093 cycles per second.

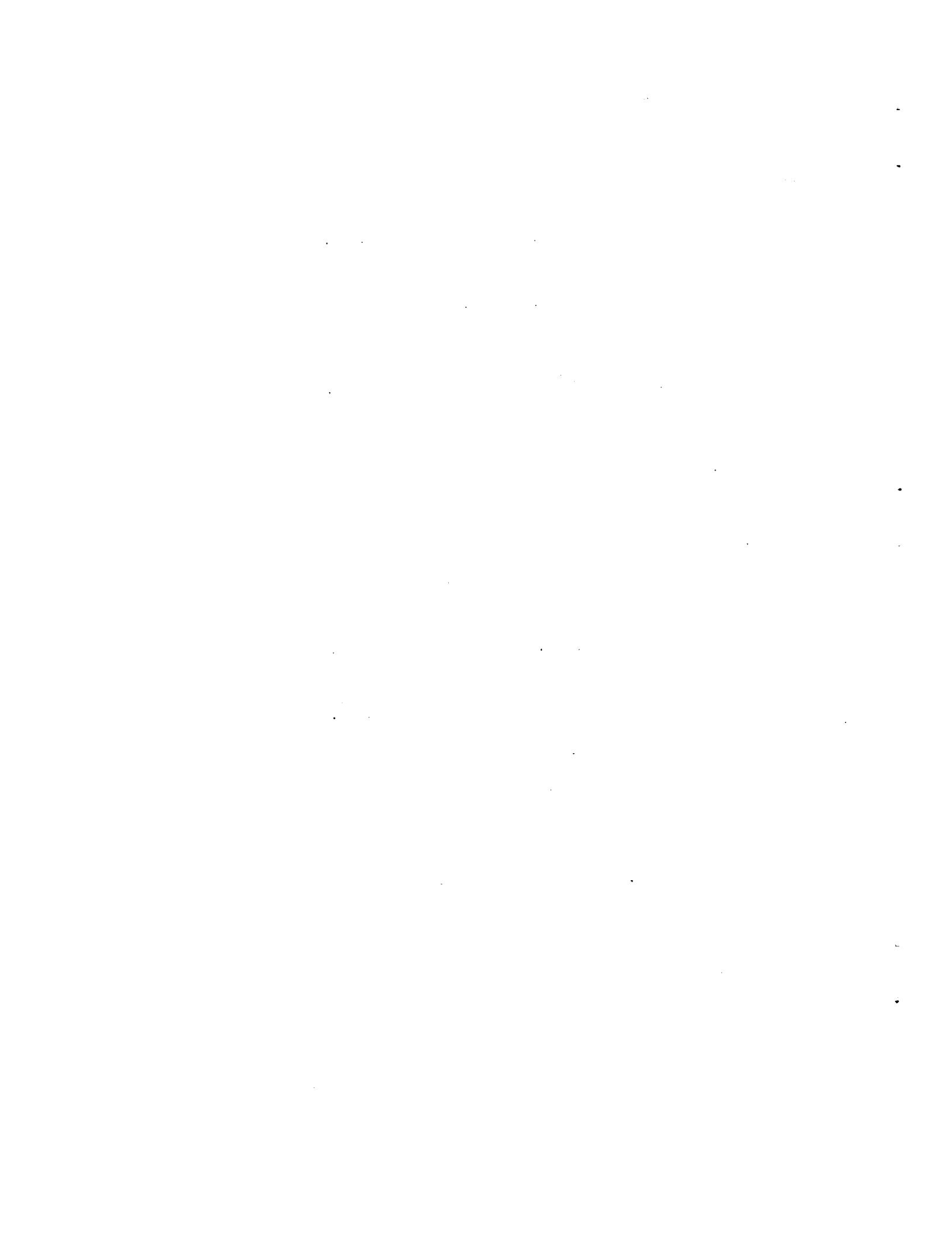

TABLE VIII
Composite Panels with Balsam Wool, Hair Felt, and Cotton

Front panel Material	Thickness (in.)	Filler	Rear panel Material	Thickness (in.)	Weight (lb./sq.ft.)	Transmission loss in decibels at frequency bands of			Average	Gain
						150-220	400-470	1000-1120		
37 Aluminum	0.025	½-inch balsam wool, paper each side	Aluminum	0.025	0.90	17.6	15.1	51.8	21.5	-2
38 do.	.025	4 layers ½-inch cotton separated by paper	do.	.025	1.20	25.0	24.5	29.4	26.6	1
39 do.	.025	½-inch balsam wool, paper each side 1-inch balsam wool, paper each side	do.	.025	1.23	20.8	27.6	41.8	30.1	4
40 do.	.025	do.	Insulite	.51	1.31	20.3	30.9	43.9	31.7	5
41 do.	.025	Same as 39 with 0.00½-inch aluminum in center	Aluminum	.025	1.31	20.7	26.9	42.7	30.4	4
42 Plywood	.125	Same as 39	Plywood	.125	1.57	31.4	32.2	40.6	34.7	7
43 Aluminum	.025	2 layers 1-inch hair felt	Aluminum	.025	2.06	26.8	23.1	39.8	29.9	0

TABLE IX
Composite Panels with Dry Zero Blanket

	Front panel Material	Thick- ness (in.)	Filler	Rear panel Material	Thick- ness (in.)	Weight (lb./sq.ft.)	Transmission loss in decibels at frequency bands of			Aver- age	Gain
							150- 220	400- 470	1000- 1120		
44	Airplane fabric ¹	-	2-inch dry zero	Imitation leather	-	0.47	16.1	17.8	27.2	20.4	2
45	do. ¹		do.	Micarta	0.047	.52	17.5	19.6	27.1	21.4	2
46	Aluminum ¹	0.025	do.	Imitation leather	-	.72	19.9	25.7	35.0	26.9	5
47	do. ¹	.025	do.	Micarta	.19	.77	21.9	25.9	36.5	28.1	6
48	do.	.025	do.	Aluminum	.025	.89	22.5	23.2	33.7	26.5	3
49	do.	.025	do.	Insulite	.31	.97	26.7	25.9	37.6	30.1	6
50	do. ²	.025	do.	do.	.31	.97	28.6	35.6	45.0	36.4	12
51	do. ¹	.025	do.	Plymetal	.125	1.00	26.6	30.5	36.5	31.2	7
52	do.	.025	do.	Plywood	.125	1.06	27.0	27.5	34.9	29.8	5
53	do.	.025	2 layers 2-inch dry zero	Aluminum	.025	1.08	24.3	24.0	32.7	27.0	2
54	Plywood	.125	2-inch dry zero	Plywood	.125	1.23	29.1	26.9	39.4	31.8	6

¹For these materials the frequency bands were 150-180, 400-440, and 1000-1093 cycles per second.

²Large panel, 70 by 84 inches, 1-3/4 by 1-3/4 inches framing every 16 inches running the shorter way.

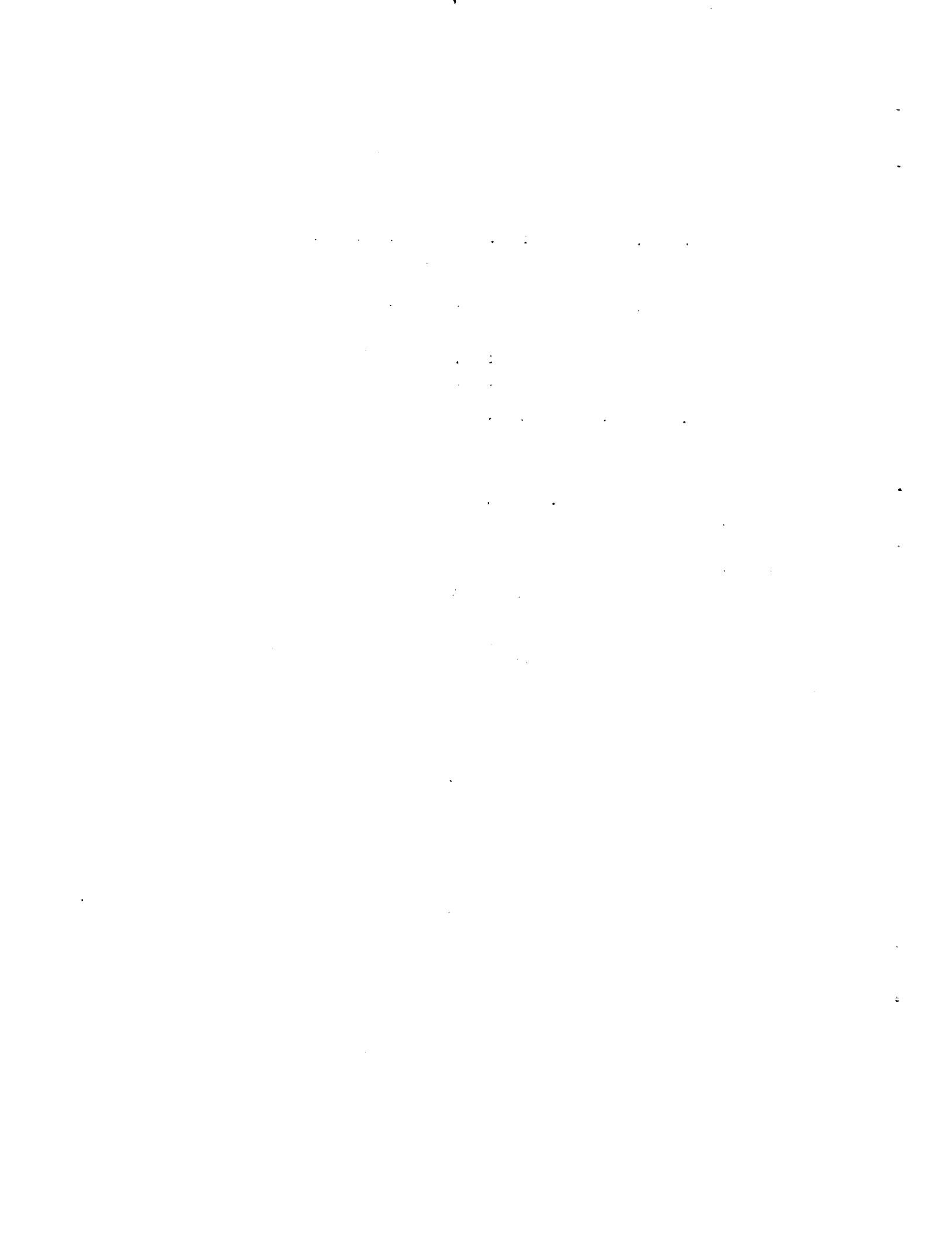

TABLE X
Chart Showing Materials and Methods of Applying Sound and Heat Insulation
to Airplanes as Used by Various Manufacturers

Airplane model and Manufacturer	Material	Manufacturer	Location and method of application
Curtiss-Wright (Condor)	Insulite, 1/8- by 1/4- inch thick, flameproof. Seapak, 1/8-inch thick, flameproof.	Insulite Mfg. Co., Minneapolis, Minn. Seaman Paper Co., Chicago, Ill.	Cabin: Insulite and Seapak nailed to wooden cabin framing.
Boeing (General practice)	Laminated pliofilm and cheese-cloth Dry zero blankets Felted kapok Casement cloth	Doecknum Company, Cleveland, Ohio. Dry Zero Corp., Chicago. American Felt Co., Chicago, Ill. L. C. Chase & Co., New York City or Moss Rose, Inc., Philadelphia, Pa.	Ventilating system: 1/8-inch felted kapok covered with pliofilm. Cabin: two 1-inch dry zero blankets next to hull, various thicknesses of felted kapok, casement cloth. Material supported by hooks which are riveted to fuselage.
Douglas (Transport)	Seapak Latex cement	Seaman Paper Co., Chicago, Ill. Billings-Chapin, Cleveland, Ohio.	Seapak is attached to hull with latex cement and may be reinforced by metal strips.
Lockheed (Model 12)	Seapak Akoustikos Latex cement	Seaman Paper Co., Chicago, Ill. - Billings-Chapin, Cleveland, Ohio.	Material is glued into place with Dum Dum.
Sikorsky	Seapak Type K felt Rubatex (Cellular sponge) B-C sound deadener Neoprene cement Vultex cement	Seaman Paper Co., Chicago, Ill. do. Virginia Rubatex Co., Bedford, Va. Billings-Chapin, Cleveland, Ohio. Du Pont Company, Arlington, N. J. Vultex Chem. Co., Cambridge, Mass.	Cabins and Cockpits: Seapak and felt cemented to metal surface with Vultex cement. Rubatex attached directly to sides and deck, covered with neoprene cement. Sprayed directly to skin Sprayed or crushed on rubber. Sprayed or brushed on metal - not on felt. Ventilating ducts: lined with 1/8-inch felt.



TABLE XI

Areas and Coefficient of Absorption of the Douglas DC-1

Component surface	Area (sq.ft.)	α at predominant frequency	Absorption = * $\alpha \times$ area
Ceiling	240	0.82	197.0
Front bulkhead	45	.87	39.0
Side walls	260	.79	205.0
Rear walls	65	.87	56.5
Rug	30	.28	8.4
12 passengers at 3 sabinés*			36.0
12 chairs at 2.8 sabinés			33.6
Parcels - trim, curtains			15.0

Total absorption = $A = 590$ sabinés

*The product $\alpha \times$ area gives the number of units of absorption or the number of sabinés.

Areas and Transmissivities of the Douglas DC-1

Component surface	Area (sq.ft.)	T	Transmittance = $T \times$ area
Cabin, including floor	805.0	0.000678	0.5454
12 windows and 2.25 sq. ft.	27.5	.00875	.2400
Doors - very good closure	24.0	.00024	.0496

Total transmittance = $T = 0.8350$

Noise reduction in decibels = $10 \log_{10} \frac{A}{T} = 10 \log_{10} \frac{590}{.835} =$
28.5 decibels.

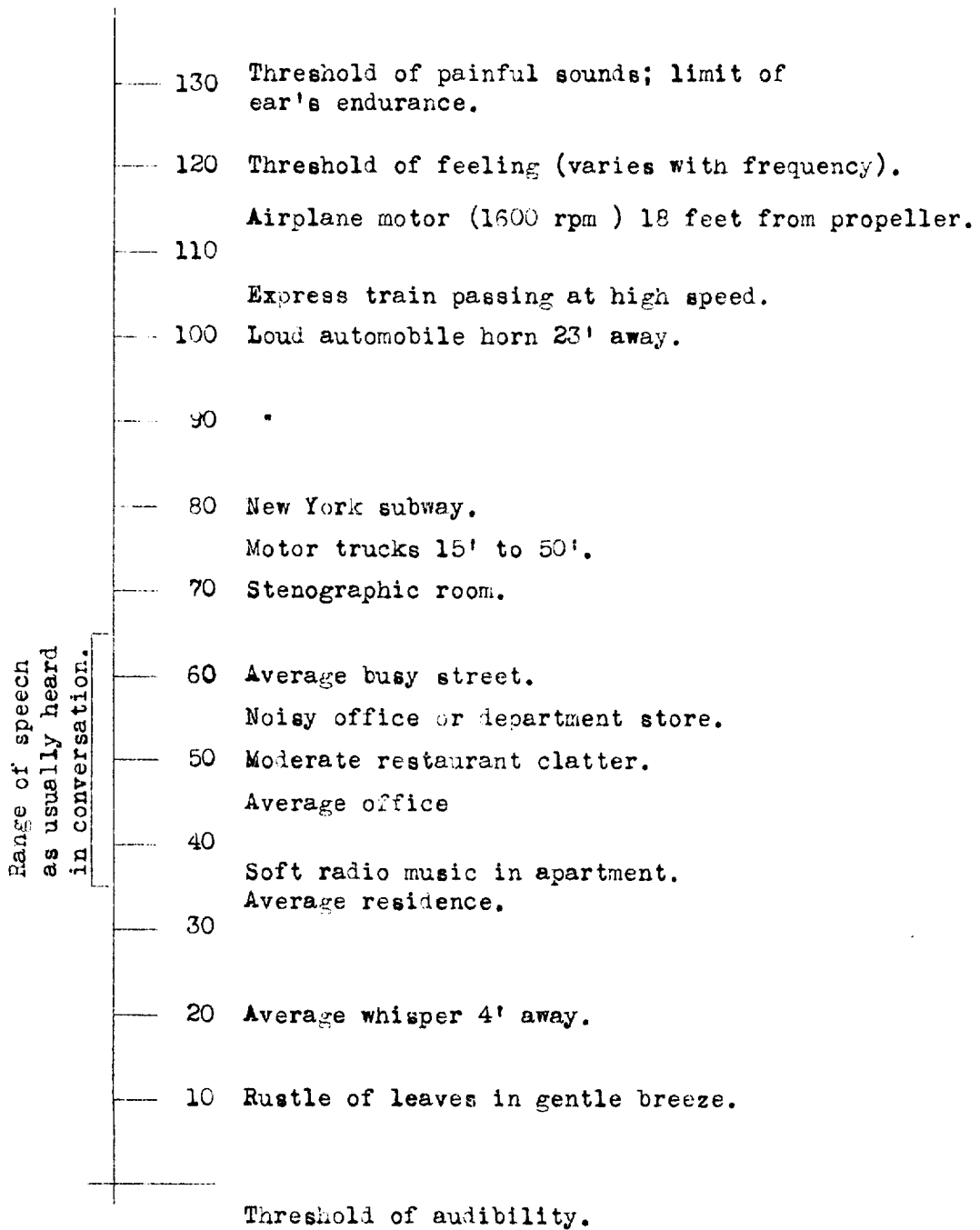

Figure 1.- Decibel scale of sound intensities.

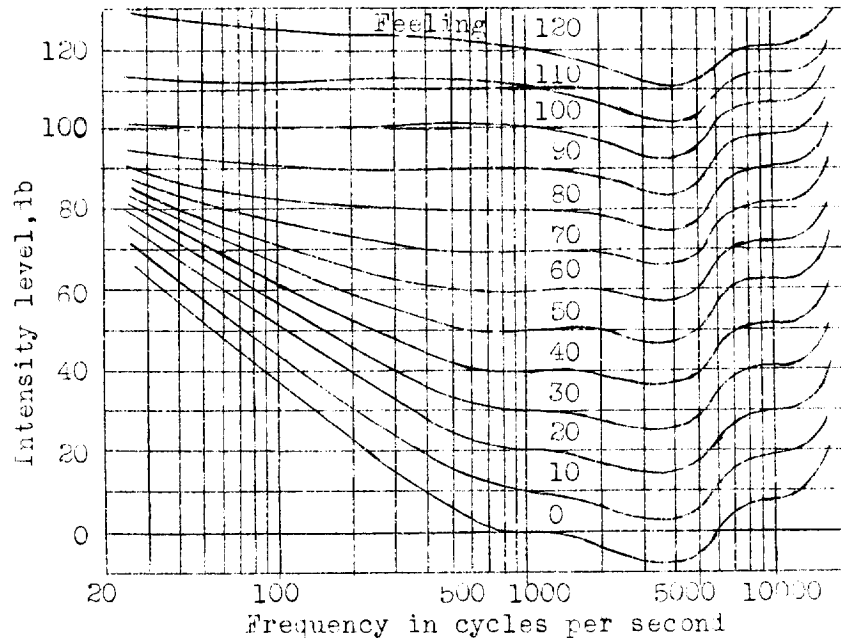

Figure 2.- Loudness level contours of the ear; each contour represents all the tones which are equally as loud as a 1000 cycle per second note. For example, an 80 cycle per second note at 70 decibels sounds as loud as a 1000 cycle note at 50 decibels.

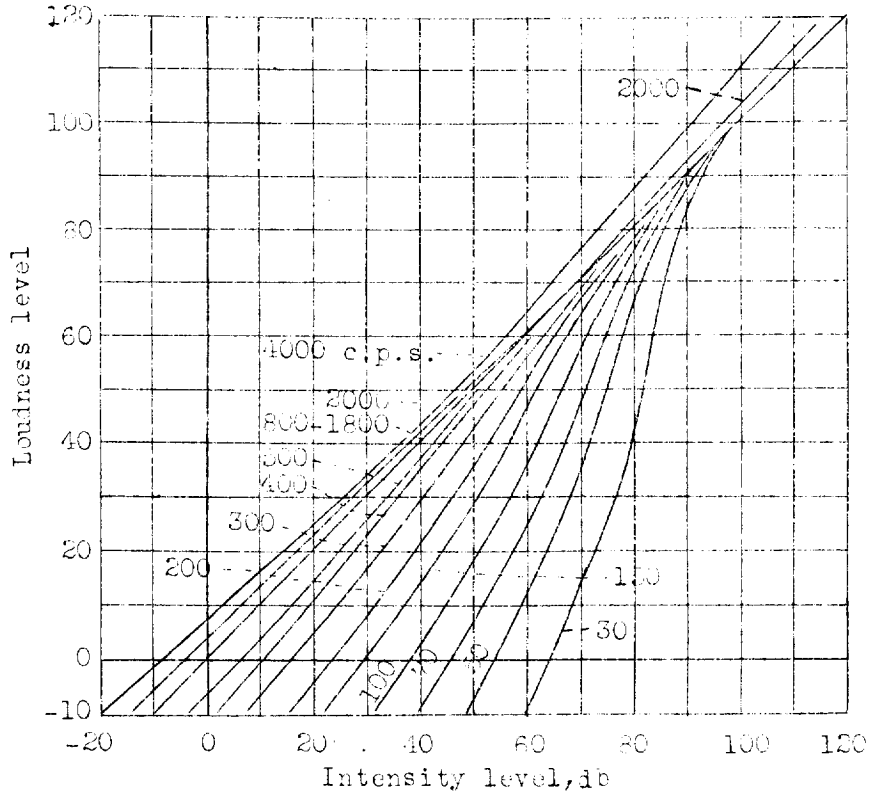

Figure 3.- Loudness level of pure tones at different intensity levels.

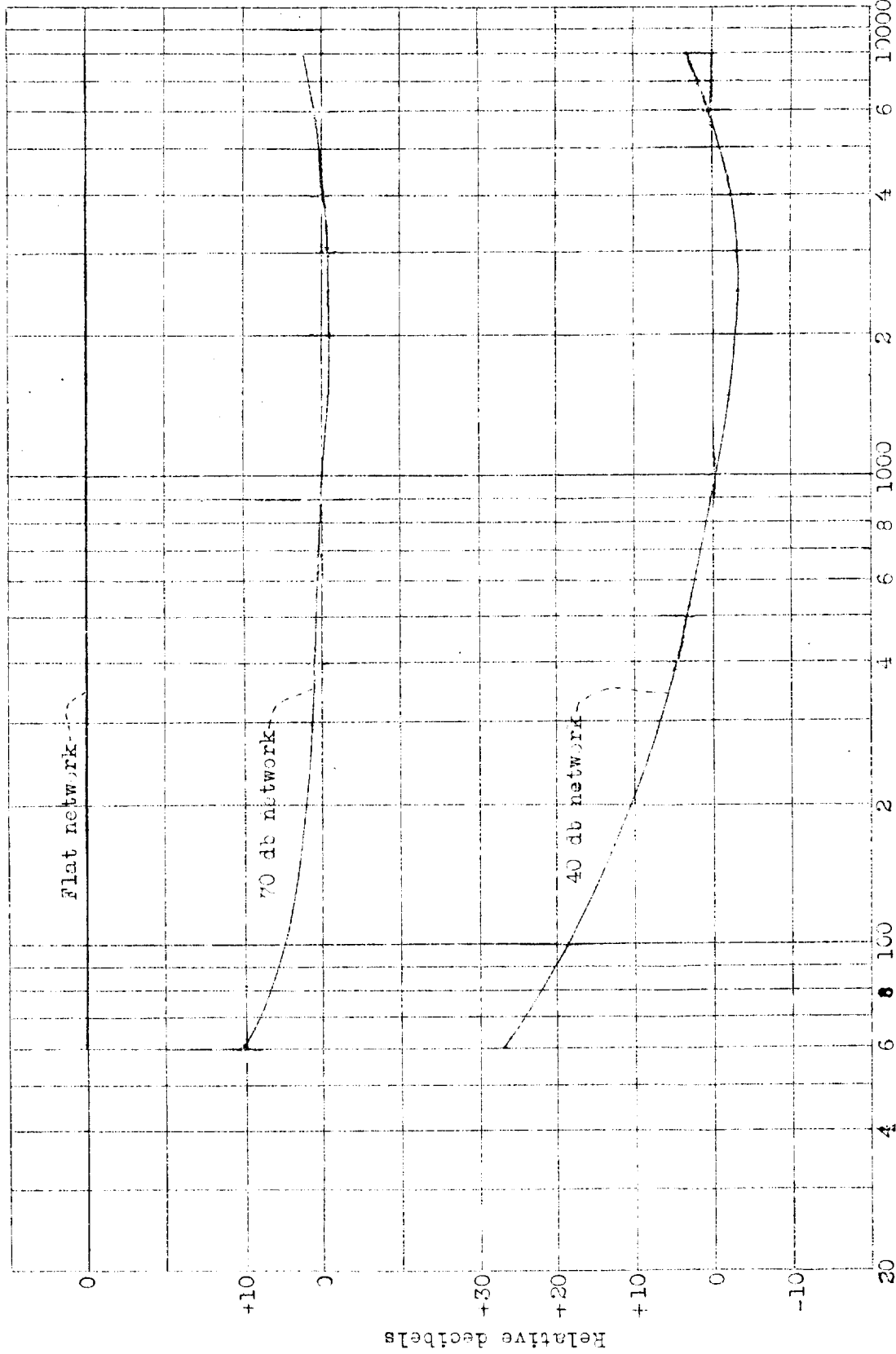
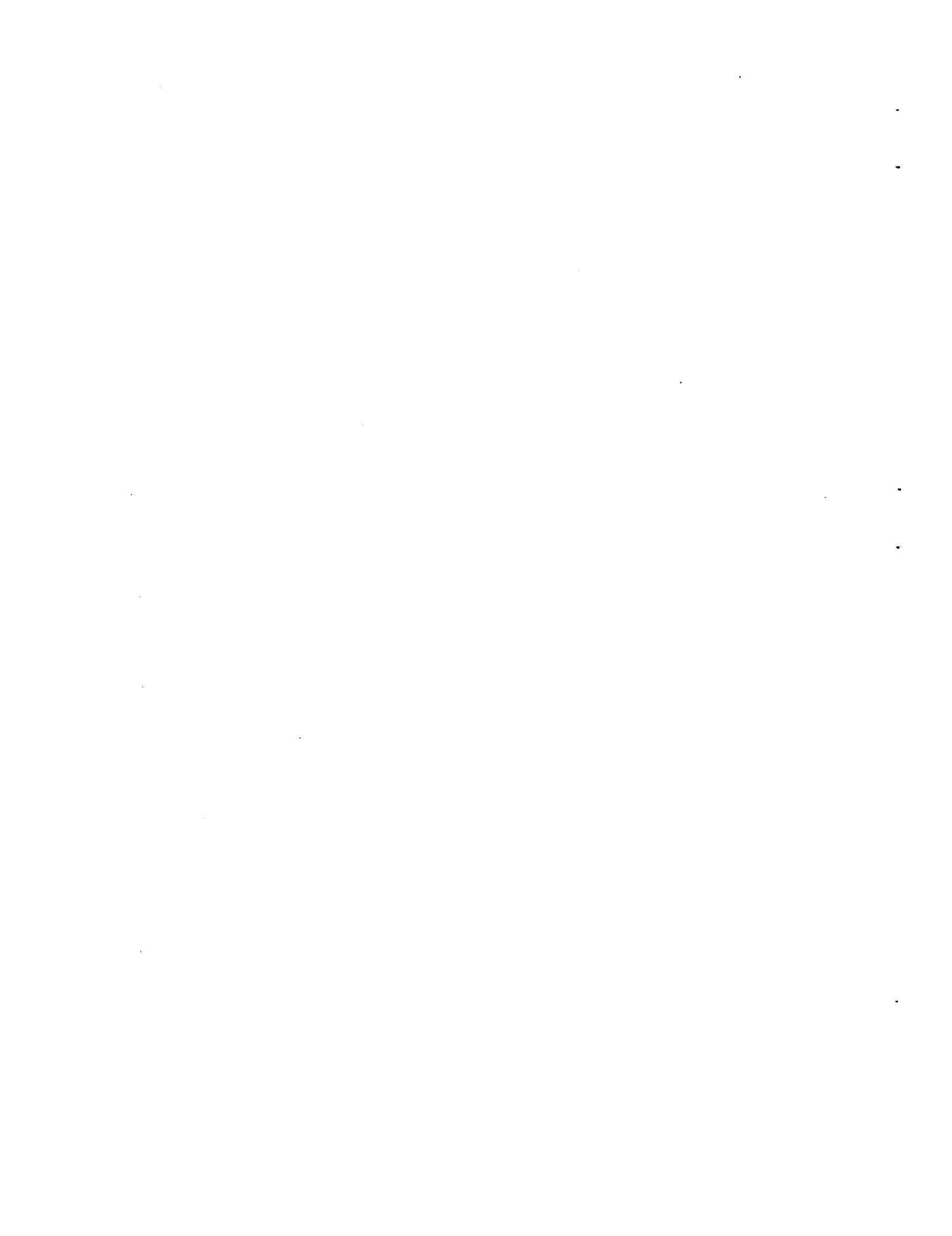

Figure 4.- Loudness level contours of the sound level meter; for example, a 100 cycle note at 75 db will give the same reading as 1,000 cycle note at 70 db.



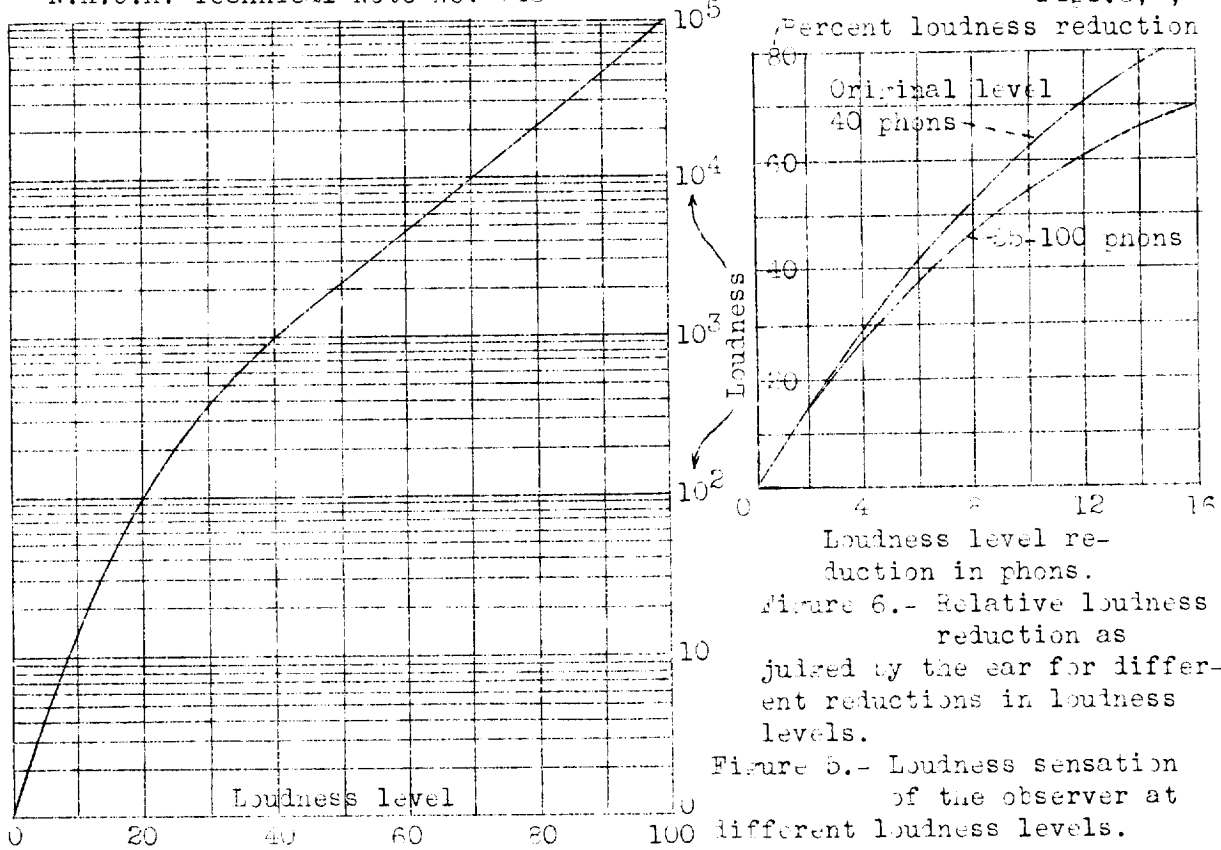

Figure 6.- Relative loudness reduction as judged by the ear for different reductions in loudness levels.

Figure 5.- Loudness sensation of the observer at different loudness levels.

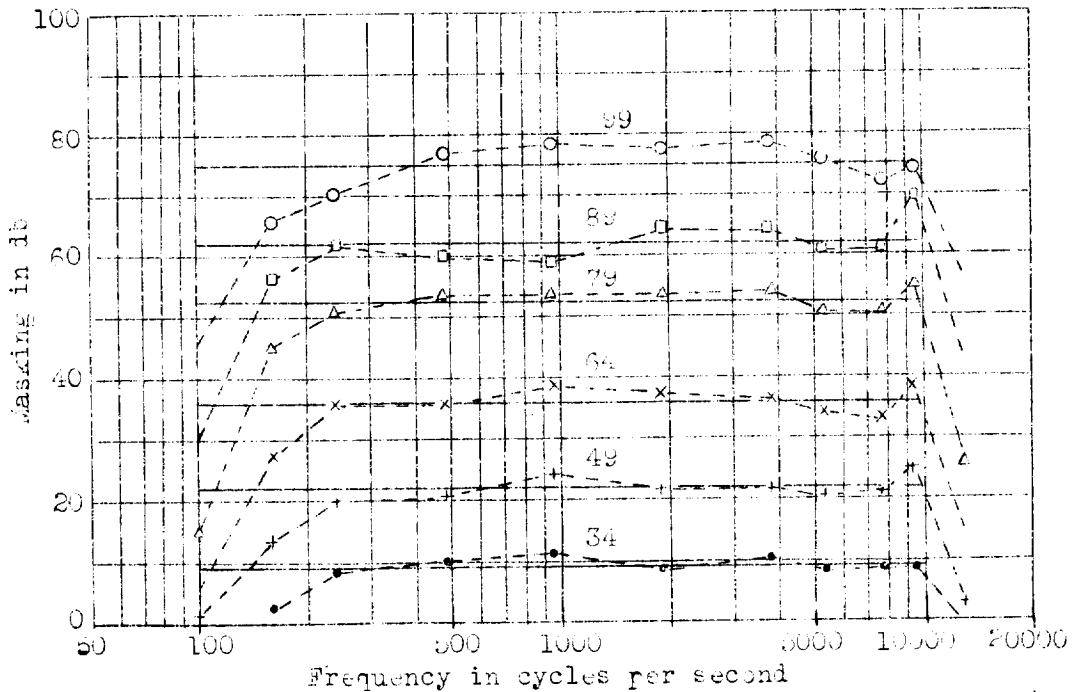
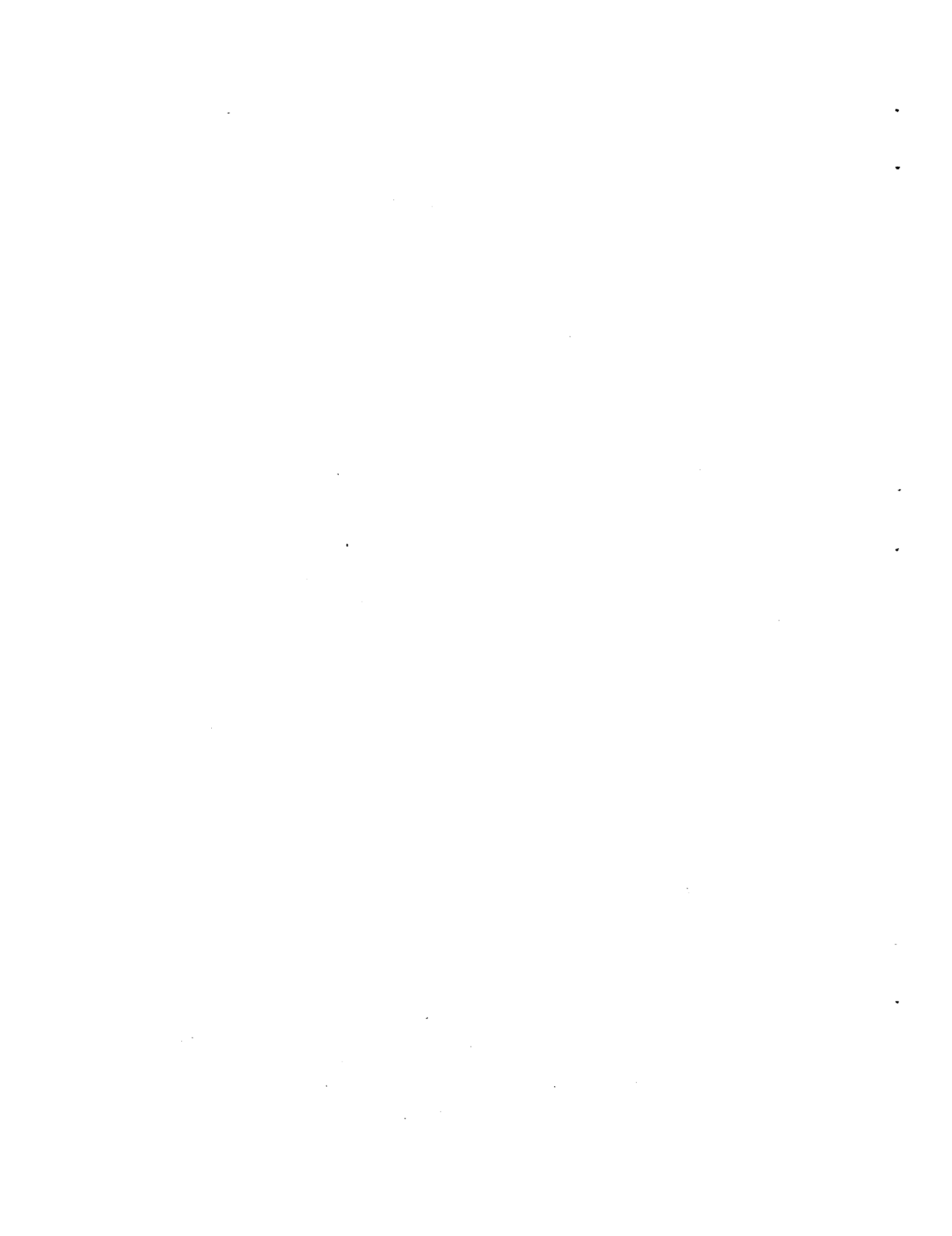

Figure 7.- Decibel shift of threshold of hearing (masking in db) in presence of noise containing a wide range of audible frequencies; numbers on the curves represent the sound level in db of the masking noise. For example, for a masking noise of 79 db, the threshold for a 500 cycle note is shifted by 53 db.



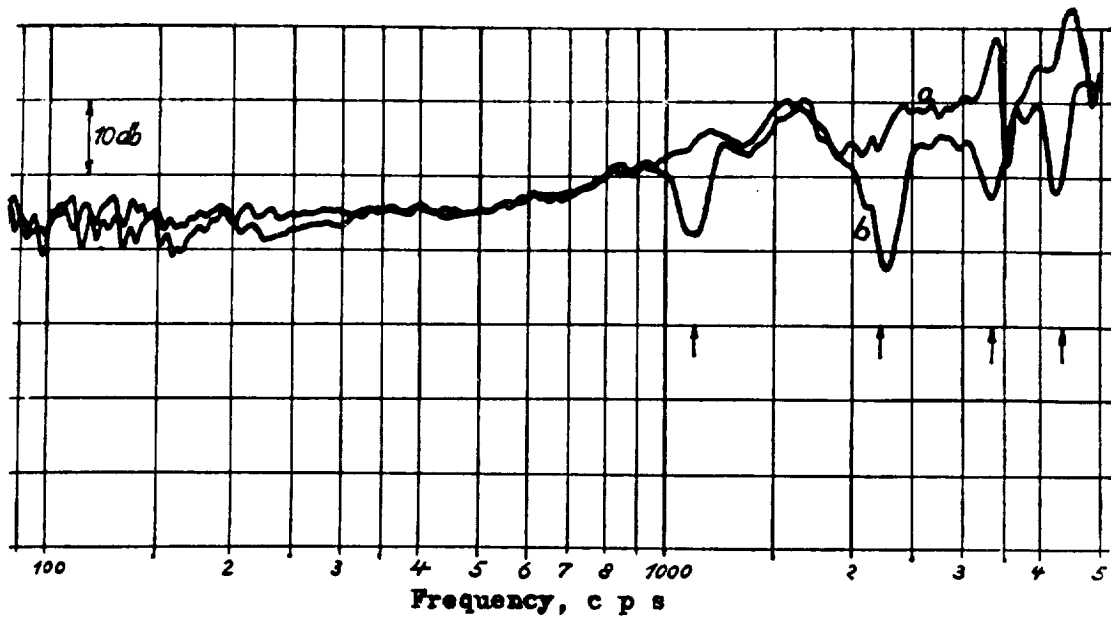

Figure 11.- Diminution in the sound insulation of a thick wall caused by a small tubular opening; a, insulation efficiency of the wall without opening; b, with an opening of 1.7 cm diameter and 15 cm length.

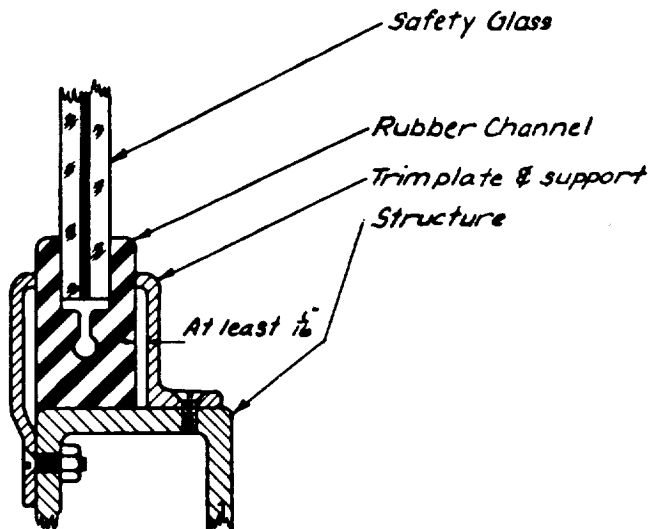
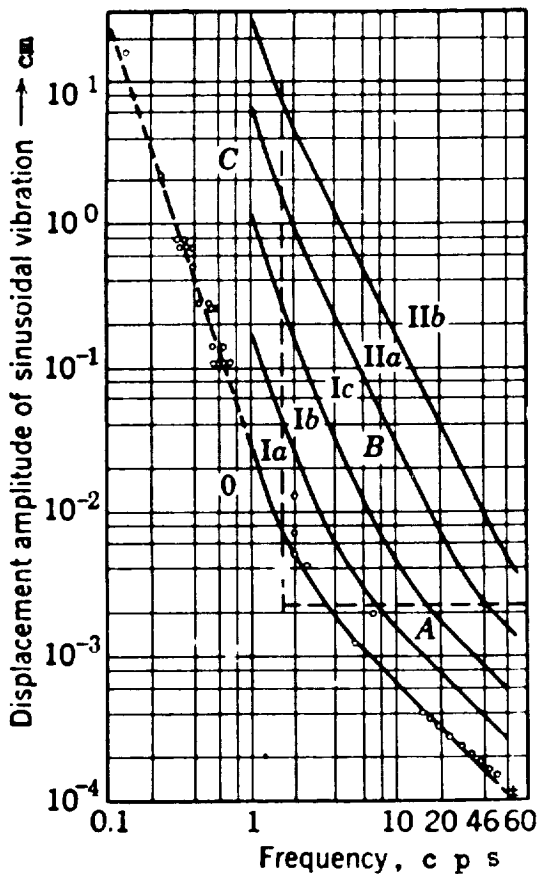
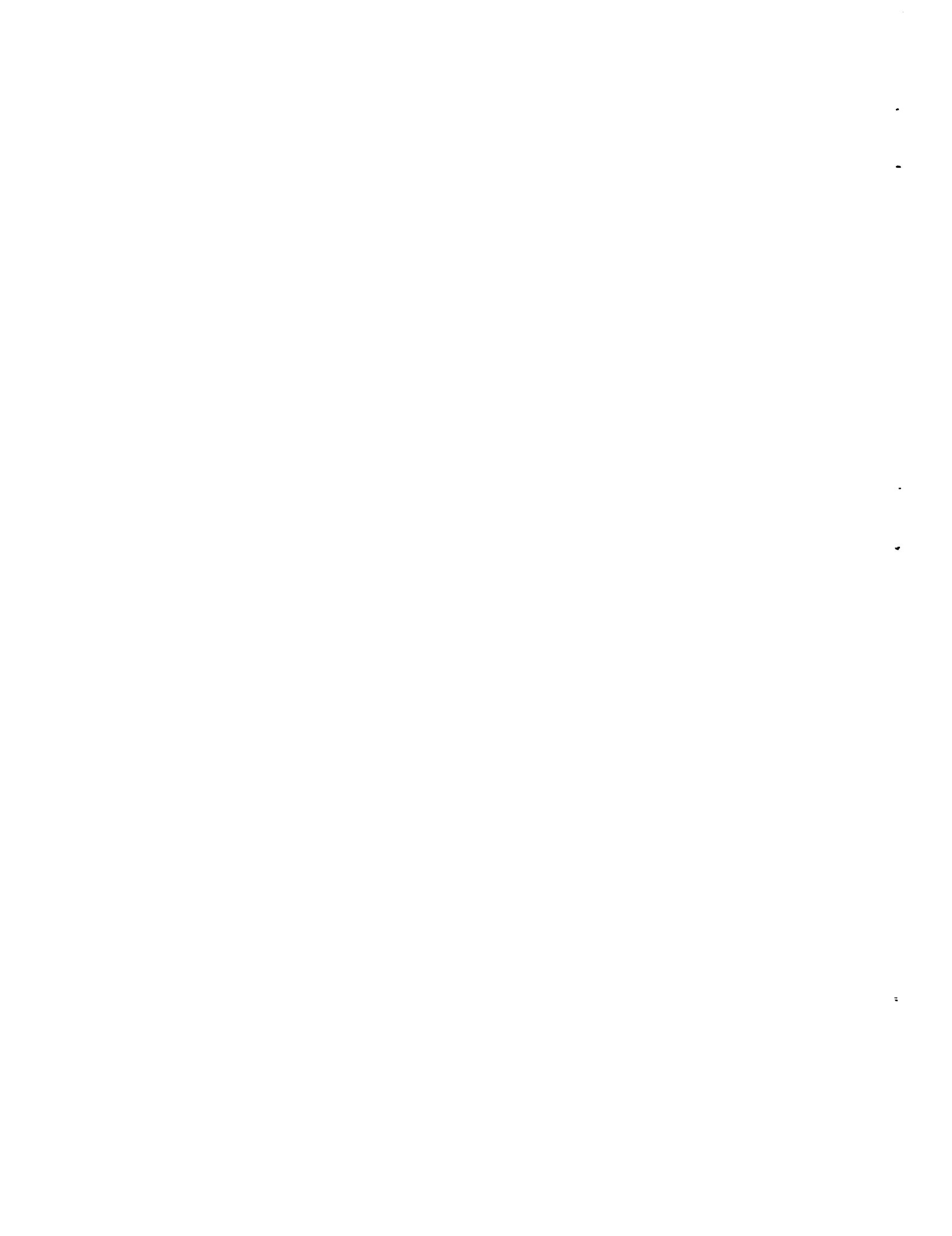

Figure 12.- Showing the construction of a proper window mounting (U.S. Patent #19991832); vibration damping is obtained by allowing space for the rubber channel to deform under the action of stresses.

Figure 8.- Response of the individual to vibration (see text).



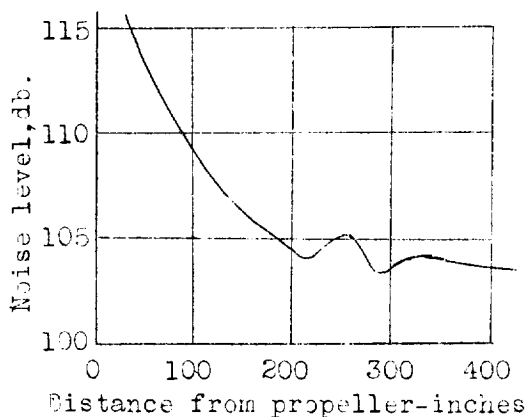

Figure 9.- Variation of noise level outside of cabin wall with distance from the plane of the propeller. Observations made at fuselage wall.

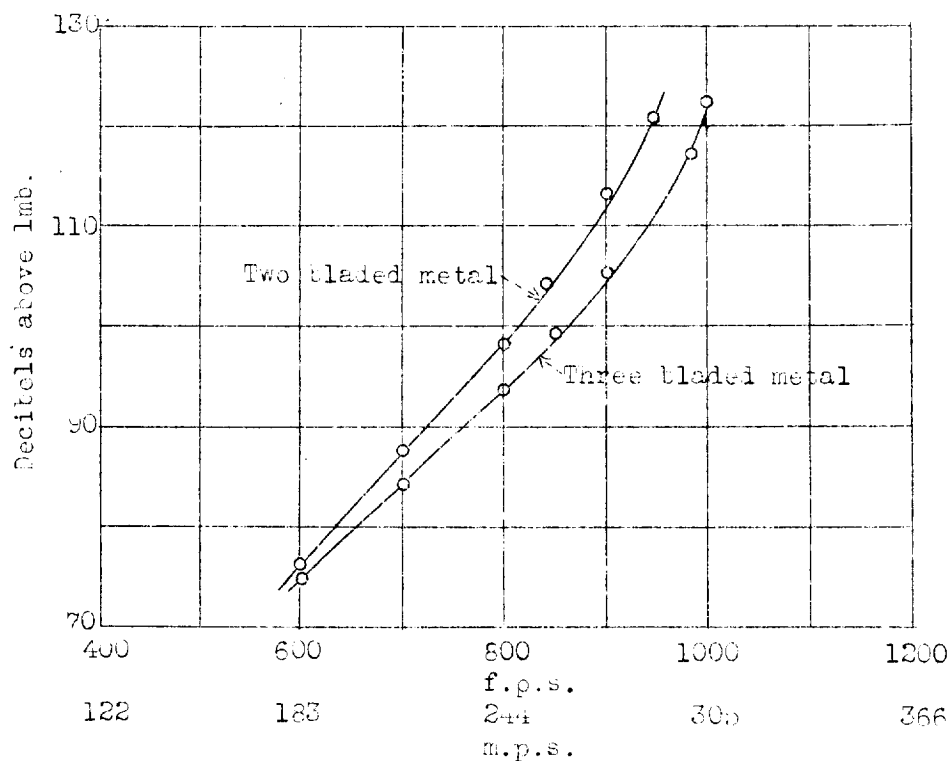

Figure 10.- Noise level (in db above 1 millibar; add 13.8 db to convert to usual reference level) produced by airscrews at various tip speeds.



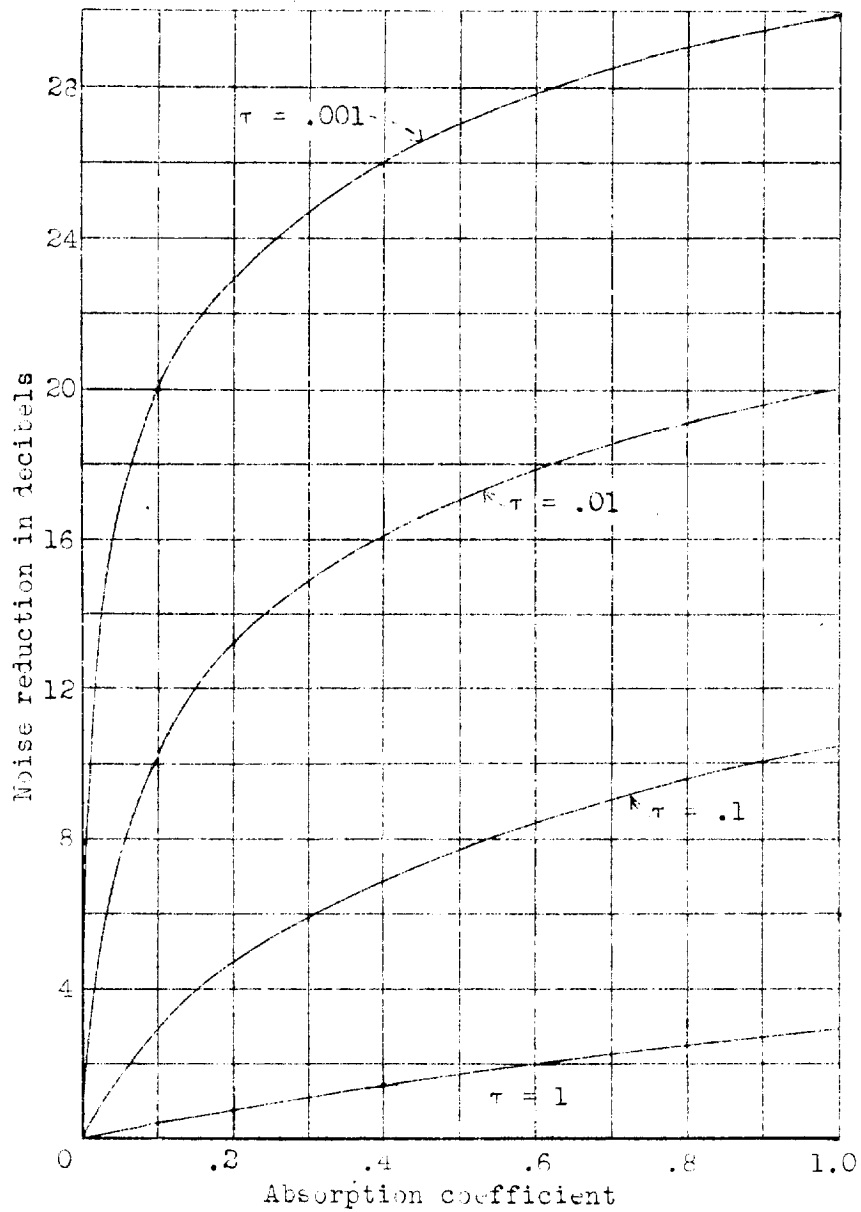
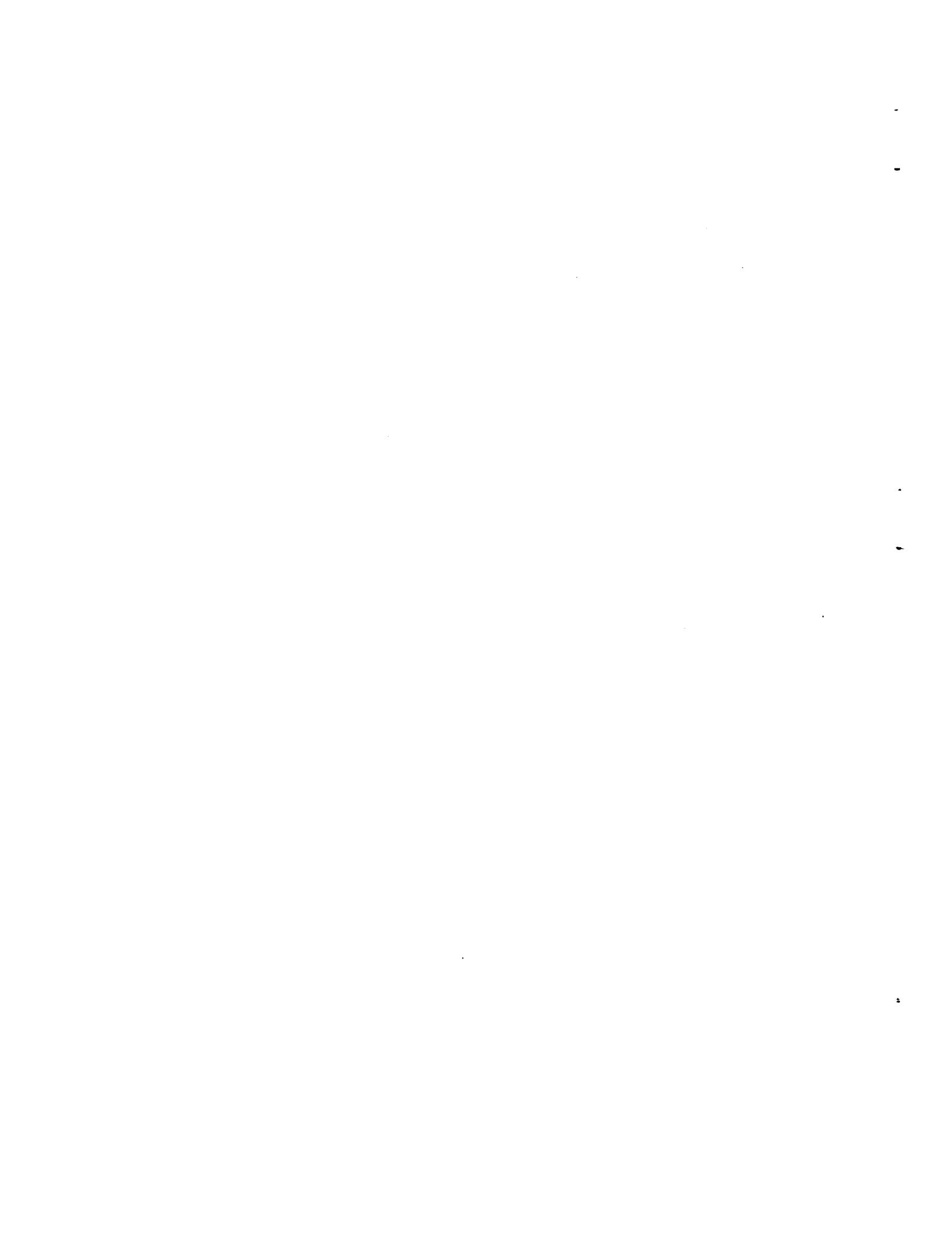

Figure 13.- Variation of noise reduction with absorption coefficient and transmissivity τ , for an idealized cabin (see text).



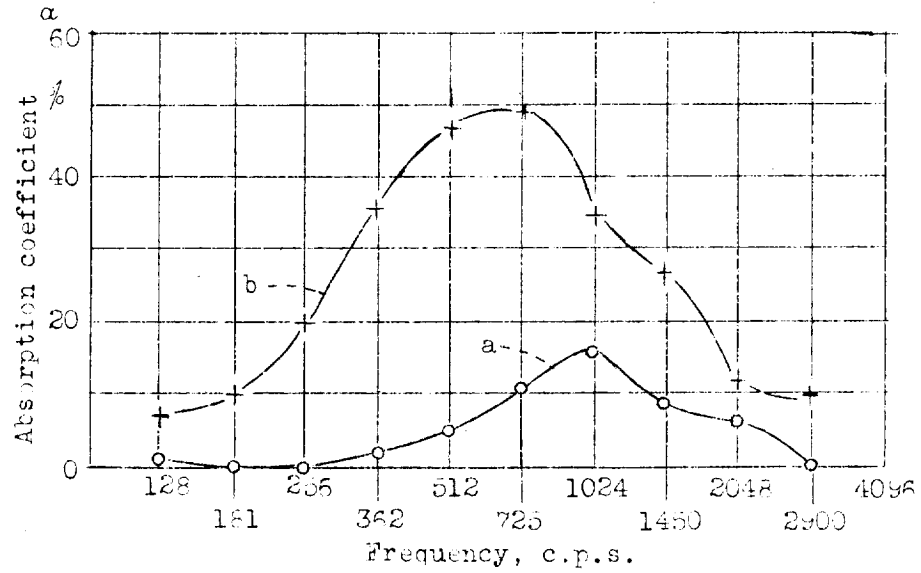

Figure 14.- Sound absorption coefficient of wrapping paper placed 5 cm from wall; a, with airspace only; b, airspace filled with cotton.

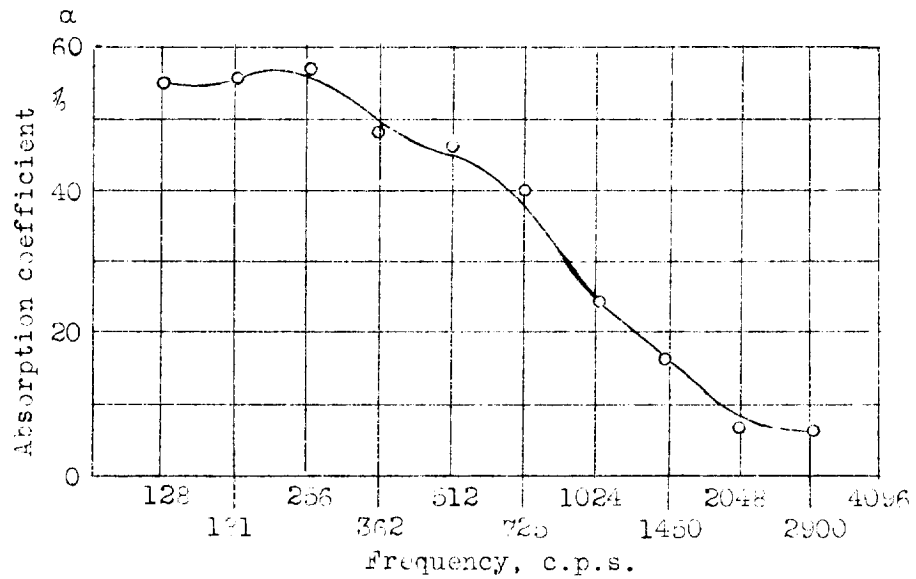

Figure 15.- Sound absorption coefficient of 3 layers of oilcloth with 5 cm airspace between layers.

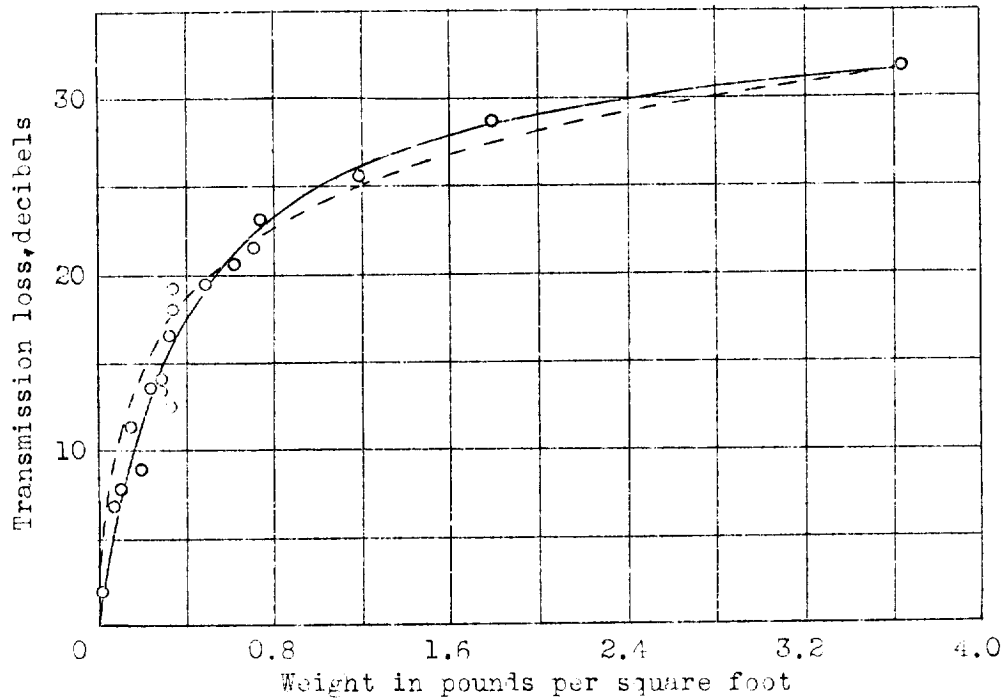

Figure 16.- Variation of transmission loss with weight for homogeneous panels.

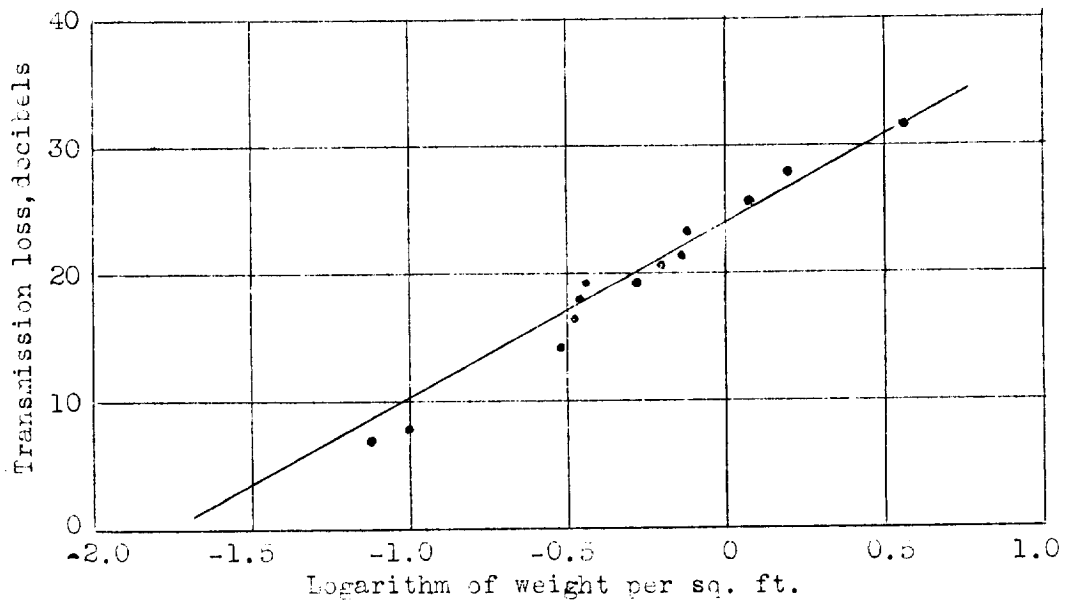
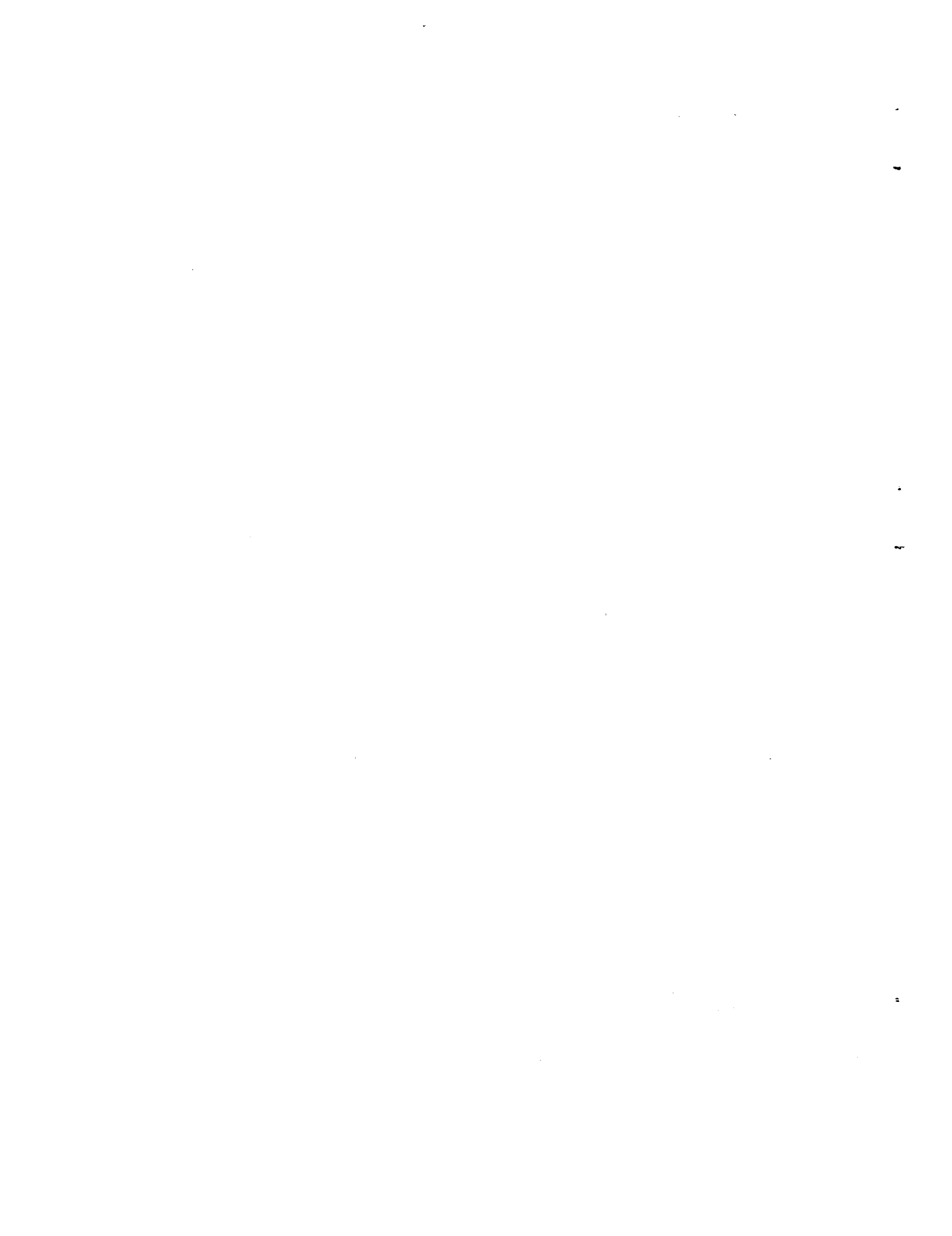

Figure 17.- Dependence of the transmission loss homogeneous panels on the logarithm of weight in lb/sq.ft.



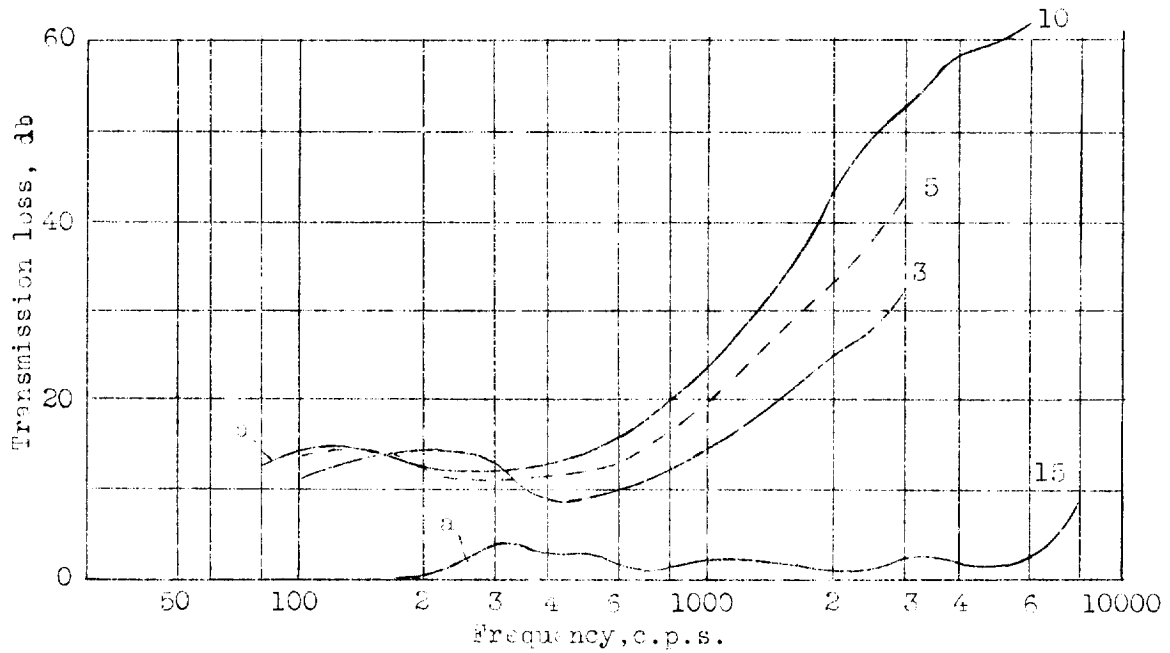

Figure 18.-Transmission loss of multiple walls: Curve a: 15 sheet cellophane wall ($f_c = 6700$ c.p.s.); curves b: 3, 5, and 10 sheet roofing-paper wall ($f_c = 200$ c.p.s.).

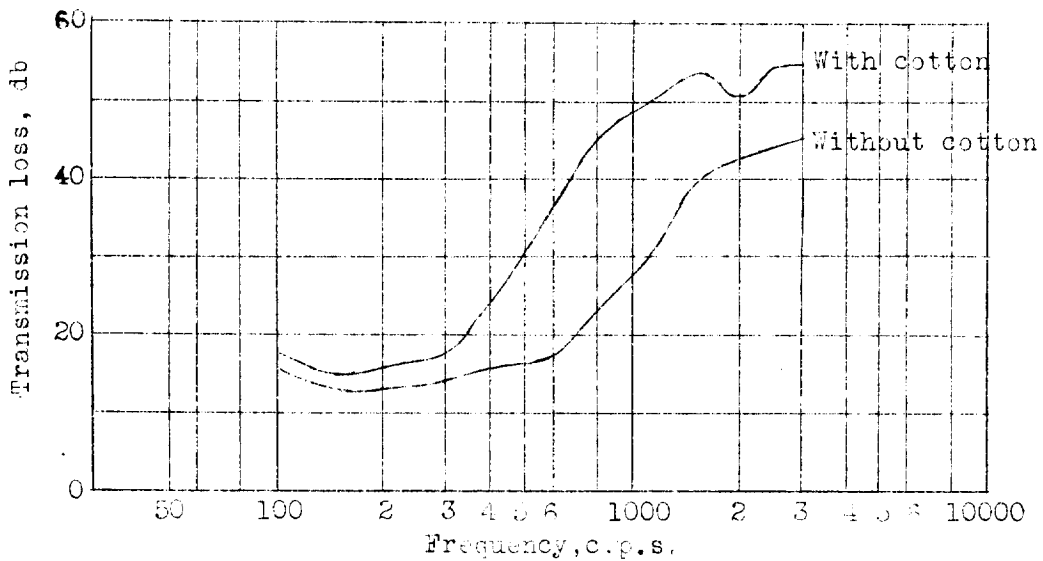
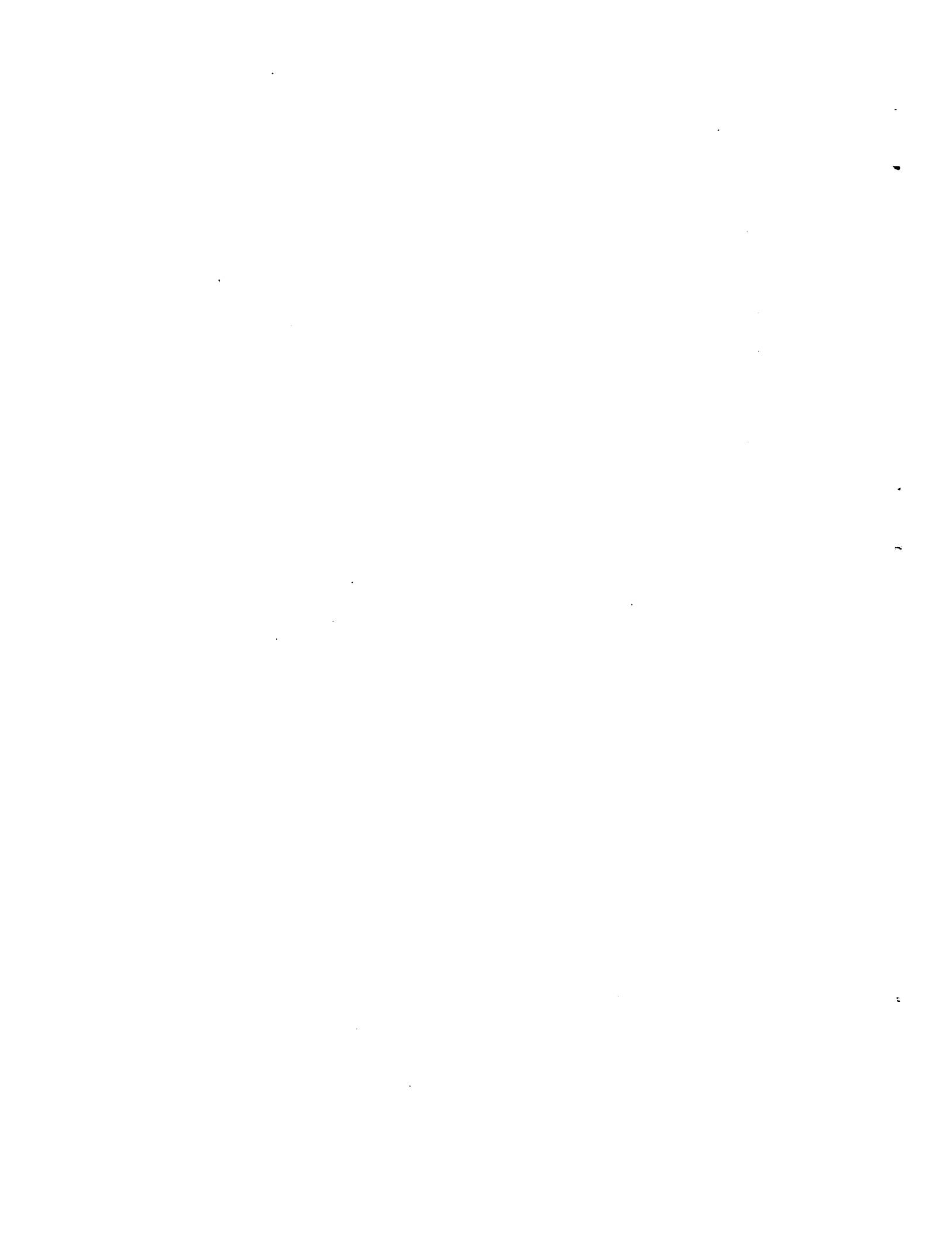

Figure 19.- Transmission loss of a wall consisting of 3 layers of plywood with and without cotton around the borders of the wall.



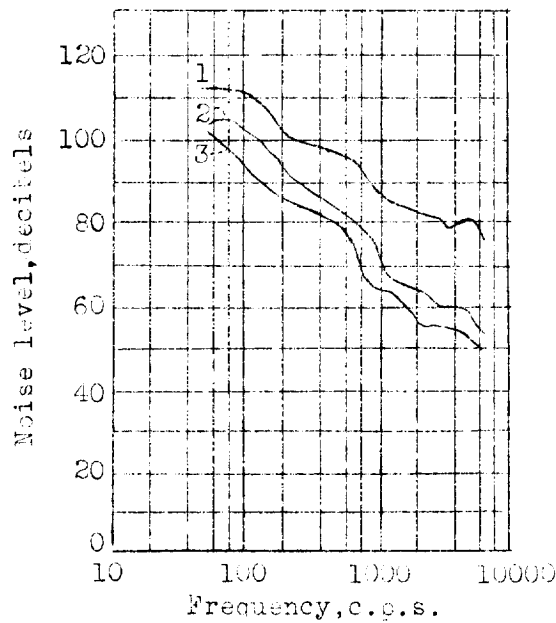

Figure 20.- Frequency analysis of the noise within the cabin; 1-FW200 without treatment, 2-FW200 with treatment, 3-Ju52 with treatment.

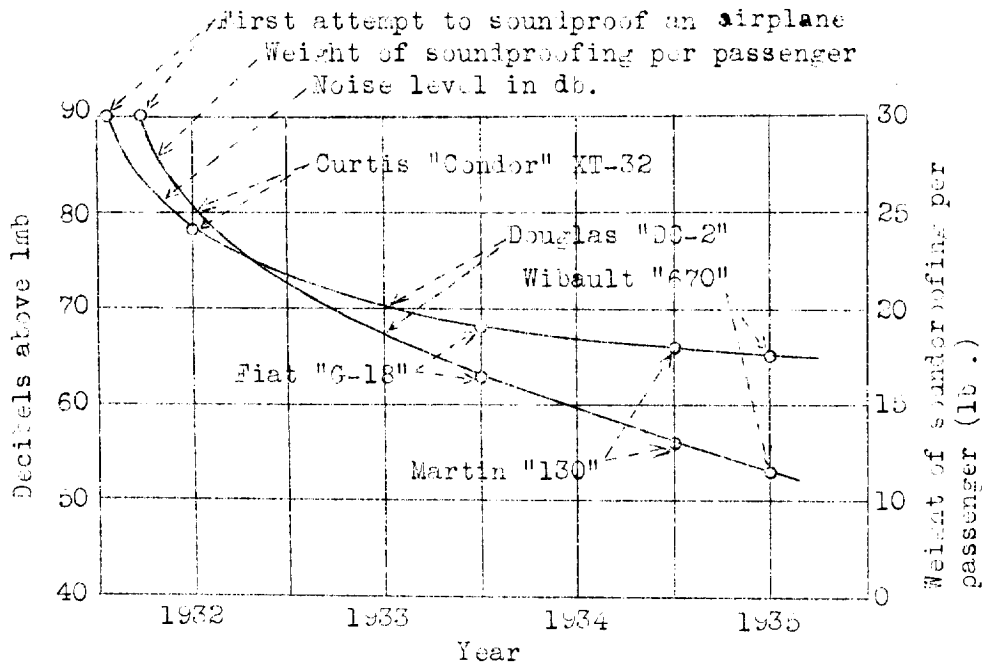
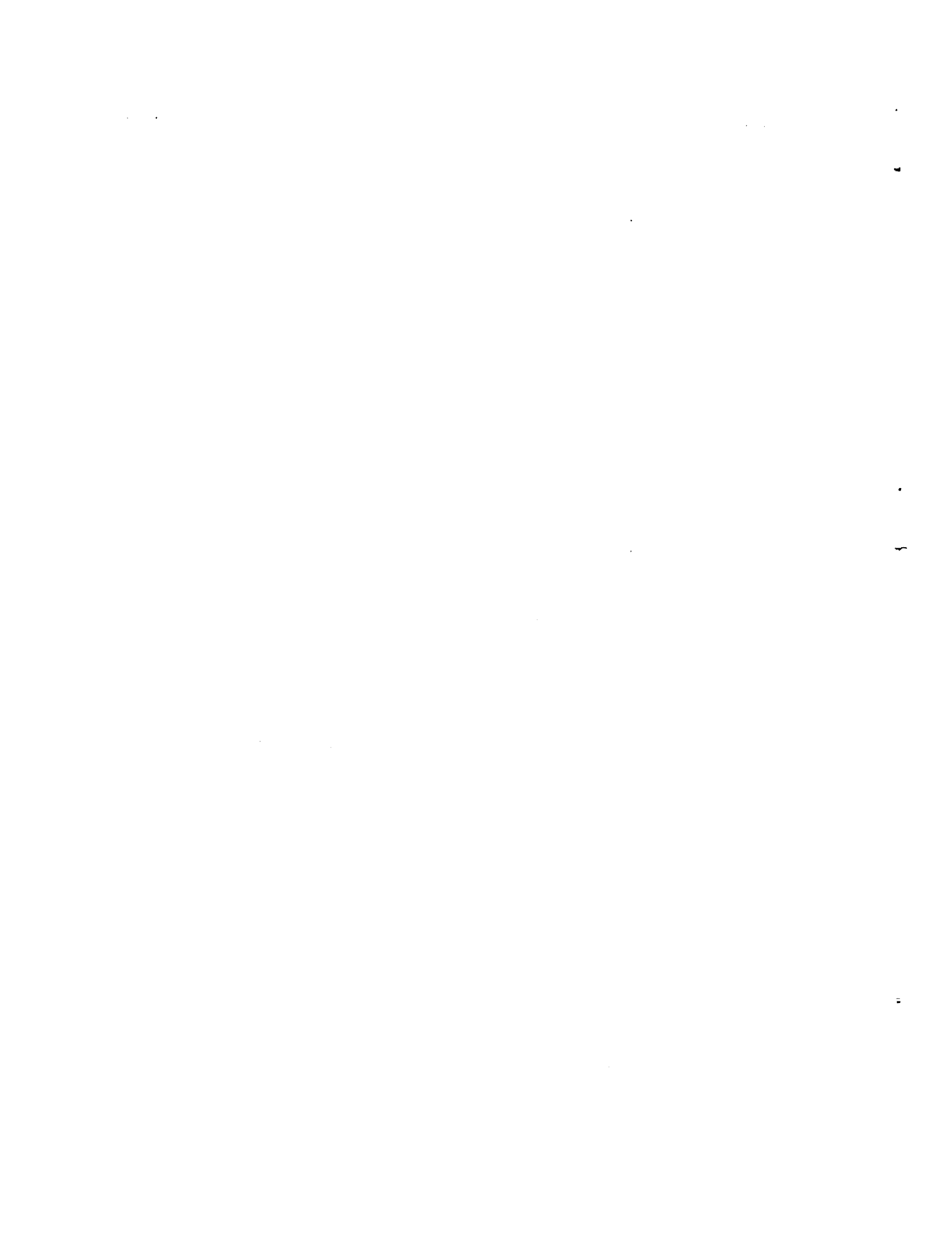

Figure 25.- Progress of soundproofing of aircraft showing the reduction of noise level and reduction in weight of acoustical treatment required. Approximately 14 db should be added to noise levels to convert to usual reference level.



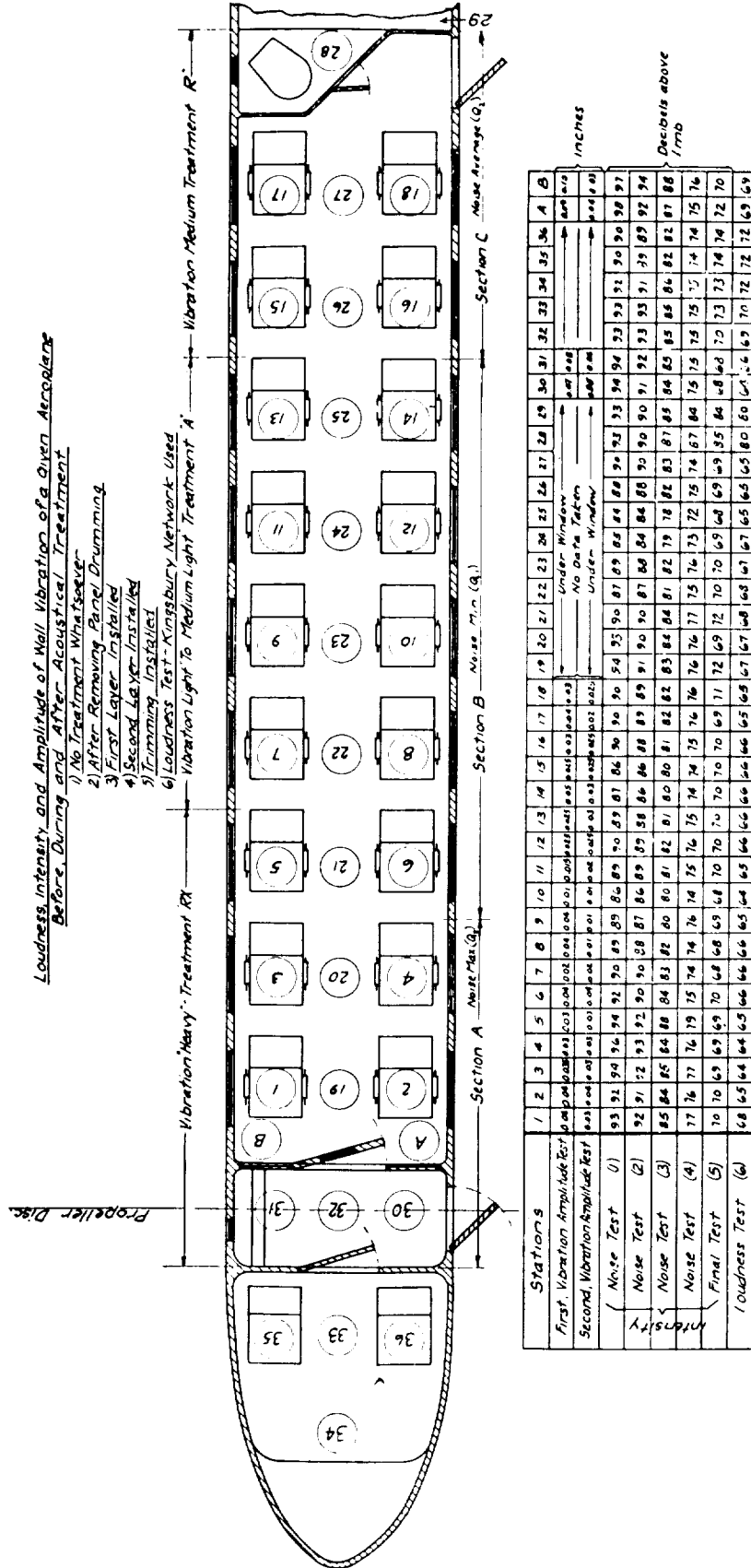

Figure 21.- Analysis of noise level and vibration amplitude existing at various positions in the plane. Approximately 14 db should be added to noise levels to convert to usual reference level.



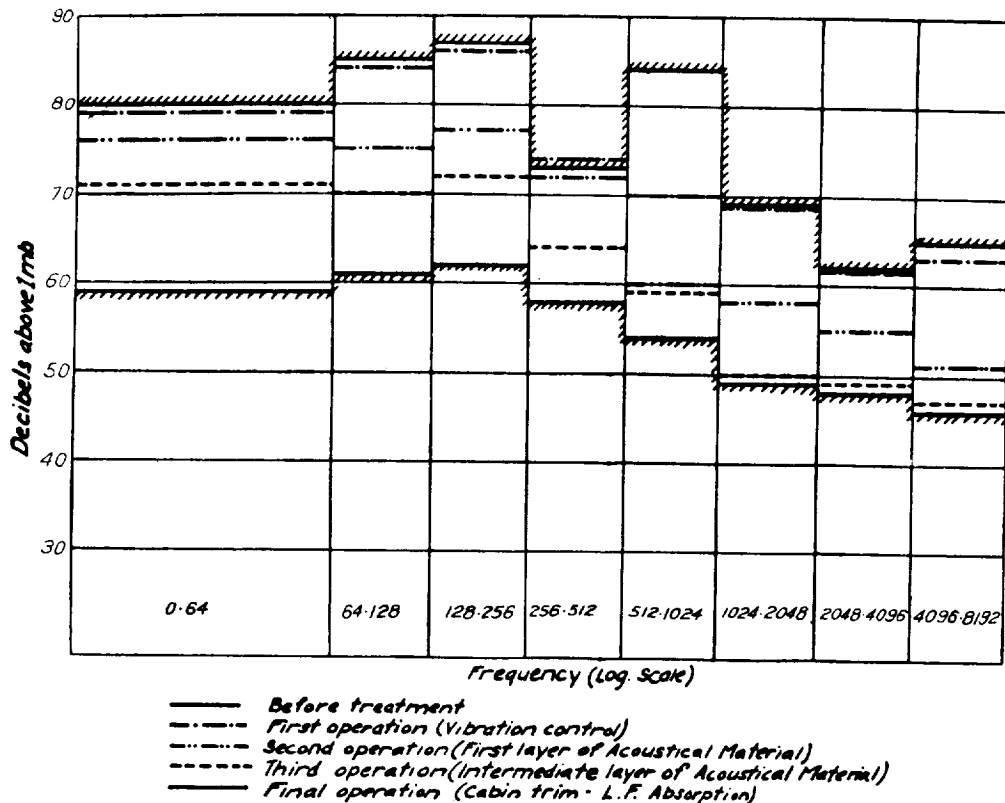

Figure 22.- Progress of noise reduction at various stages of the treatment. Approximately 14 db should be added to noise levels to convert to usual reference level.

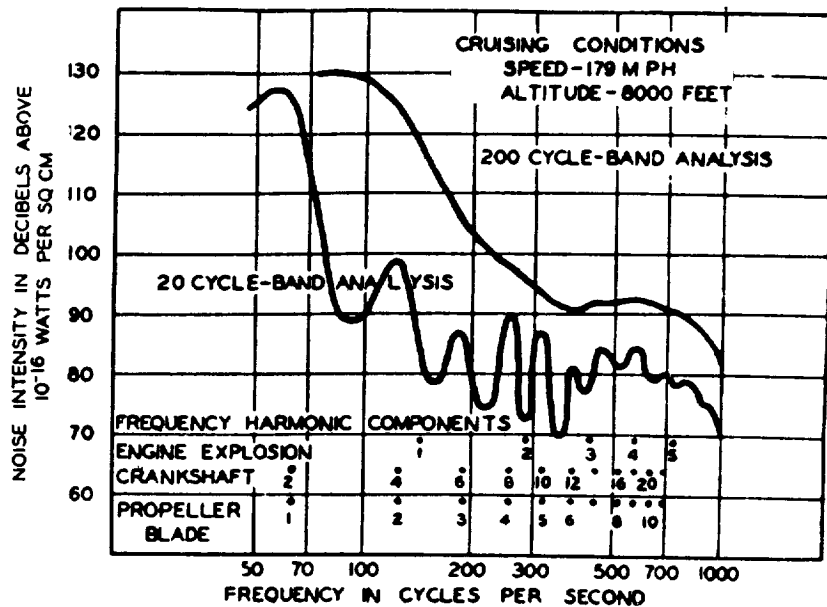
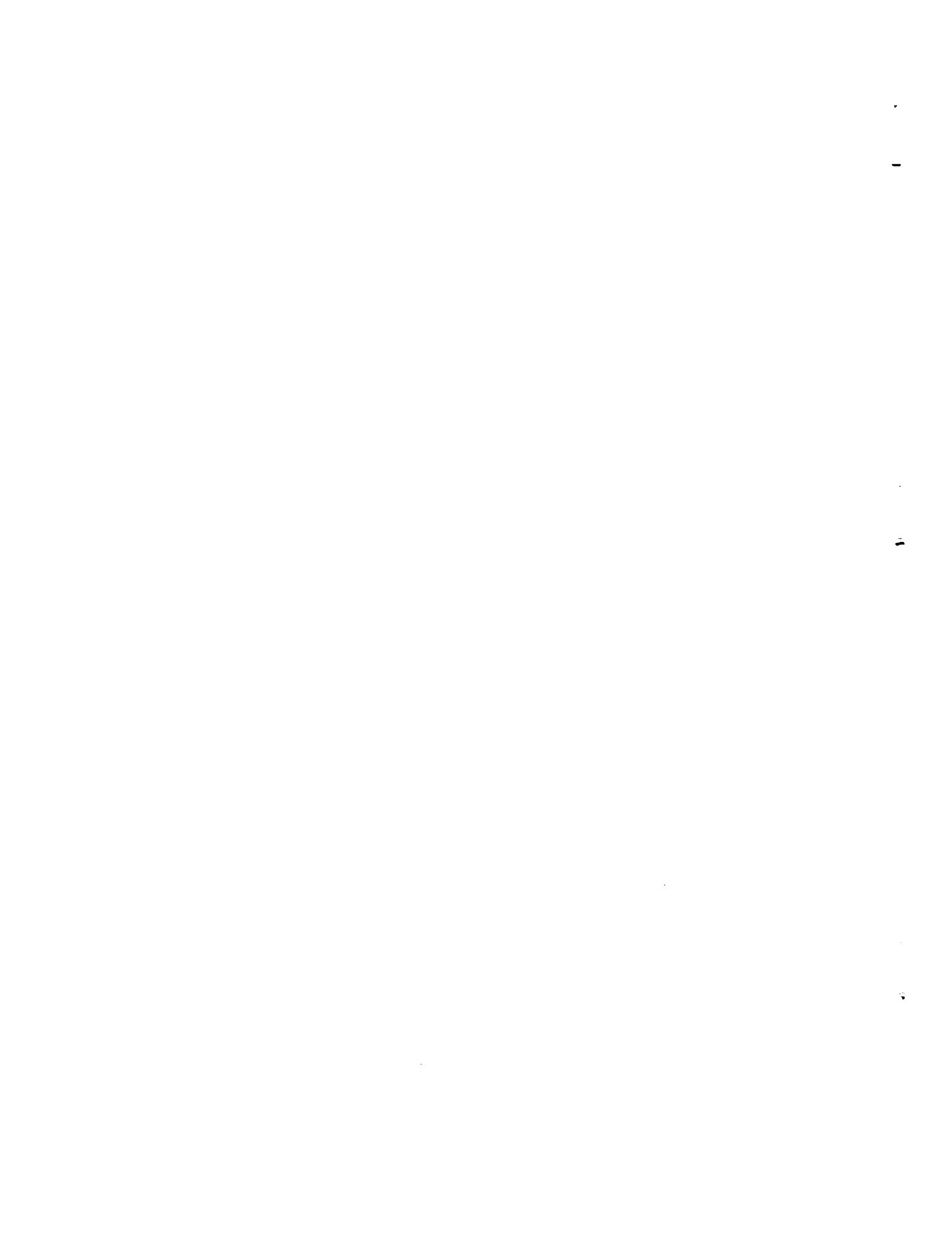

Figure 23.- Frequency analysis of noise in the pilot's compartment of an airplane with direct driven propeller.



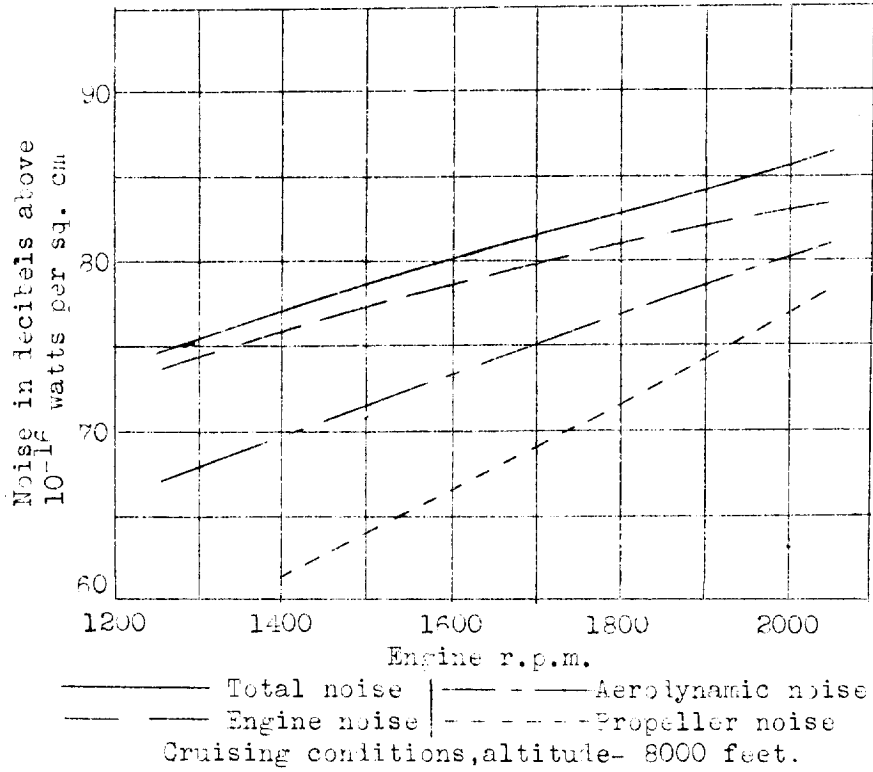

Figure 24.- Relation of the various components to the total noise in the cabin of an airplane with a three blade geared propeller.

