

# Chapter 12.

# Stereoscopic Plotting Instruments

## 12-1. Introduction

- ❖ Stereoscopic plotting instruments (commonly called *stereoplotters* or simply "plotters") are instruments designed to provide rigorously accurate solutions for object point positions from their corresponding image positions on overlapping pairs of photos
- ❖ A **stereoplotter** is essentially a three-dimensional digitizer, capable of producing accurate  $X, Y$ , and  $Z$  object space coordinates when properly oriented and calibrated
- ❖ The fact that the photos may contain varying amounts of tilt is of no consequence in the resulting accuracy  
⇒ in fact, modern stereoplotters are capable of handling oblique or horizontal (terrestrial) photos
- ❖ The **primary uses of stereoplotters** are compiling topographic maps and generating digital files of topographic information, and because these are widely practiced photogrammetric applications, the subject of stereoplotters is one of the most important in the study of photogrammetry

## 12-1. Introduction

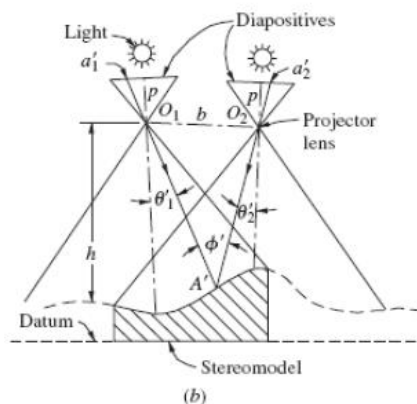
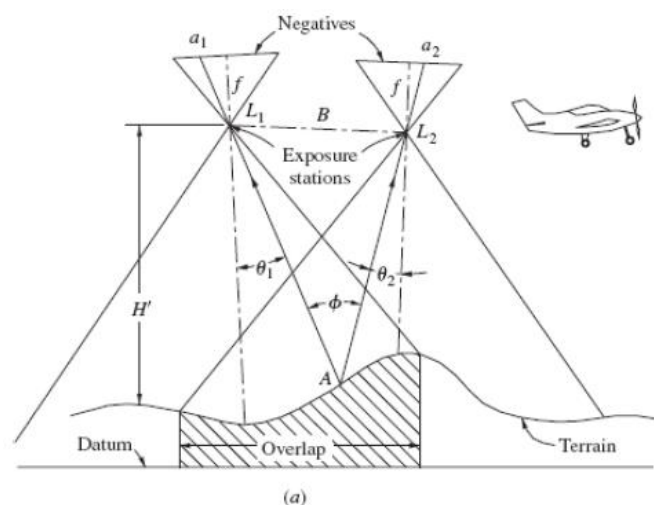

Figure 12-1. Fundamental concept of stereoscopic plotting instrument design. (a) Aerial photography; (b) Stereoscopic plotting instrument.

- ❖ The fundamental concept underlying the design of an early type of stereoplotter is illustrated in Fig. 12-1
- ❖ In Fig. 12-1a, an overlapping pair of aerial photos is exposed
- ❖ Transparencies or *diapositives*, as they are called, carefully prepared to exacting standards from the negatives, are placed in two stereoplotter projectors, as shown in Fig. 12-1b
  - ⇒ This process is called *interior orientation*
- ❖ With the diapositives in place, light rays are projected through them; and when rays from corresponding images on the left and right diapositives intersect below, they create a stereomodel (often simply called a *model*)

## 12-1. Introduction

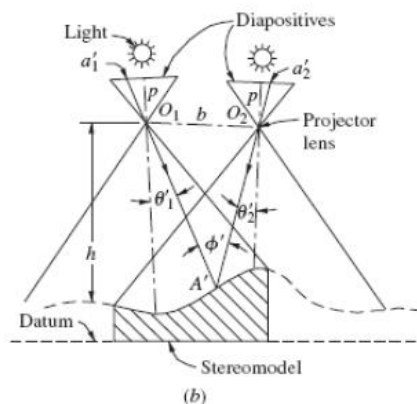
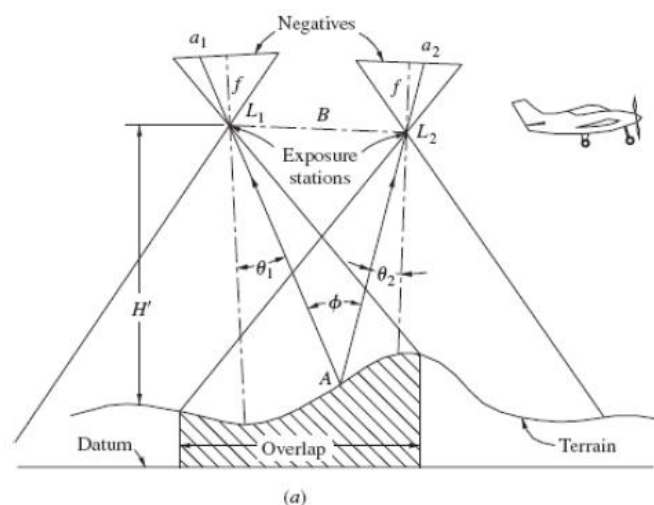

Figure 12-1. Fundamental concept of stereoscopic plotting instrument design. (a) Aerial photography; (b) Stereoscopic plotting instrument.

- ❖ In creating the intersections of corresponding light rays, the two projectors are oriented so that the diapositives bear the exact relative angular orientation to each other in the projectors that the negatives had in the camera at the instants they were exposed
- ❖ The process is called *relative orientation* and creates, in miniature, a true three-dimensional stereomodel of the overlap area
- ❖ After relative orientation is completed, *absolute orientation* is performed
  - ⇒ In this process the stereomodel is brought to the desired scale and leveled with respect to a reference datum

## 12-1. Introduction

- ❖ When orientation is completed, measurements of the model may be made and recorded, nowadays generally in digital, computer-compatible form
- ❖ The position of any point is determined by bringing a three-dimensional reference mark (the floating mark) in contact with the model point
- ❖ At the position of the reference mark, the three-dimensional coordinates ( $X$ ,  $Y$ , and  $Z$ ) are obtained through either an analog or a digital solution
- ❖ Planimetric ( $X$ ,  $Y$ ) positions and elevations ( $Z$ ) of points are thus obtained

## 12-2. Classification of Stereoscopic Plotters

❖ A variety of stereoscopic plotting instruments have been developed over the years, each with a different design

❖ As an aid to understanding **stereoplotters**, it is helpful to classify them into groups having common characteristics

⇒ This classification is divided into four general categories:

(1) *direct optical projection* instruments

(2) instruments with *mechanical* or *optical-mechanical projection*

(3) *analytical* stereoplotters

(4) *softcopy* stereoplotters

## 12-2. Classification of Stereoscopic Plotters

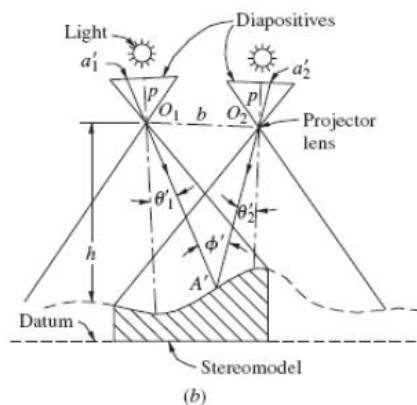
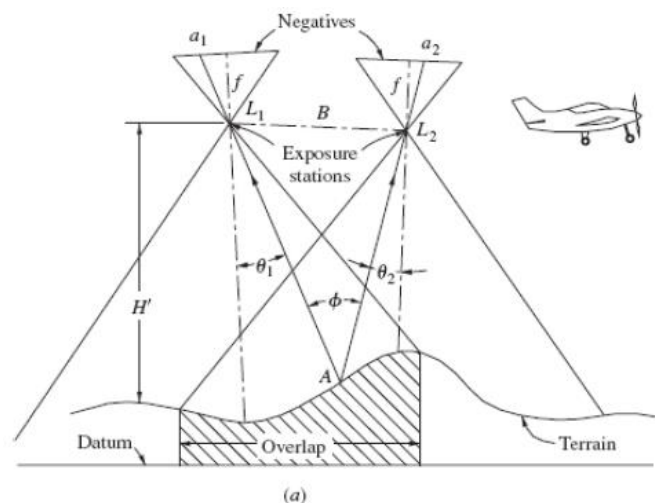

Figure 12-1. Fundamental concept of stereoscopic plotting instrument design. (a) Aerial photography; (b) Stereoscopic plotting instrument.

- ❖ The first-generation stereoplotters were of direct optical projection design, and although they are only of historic interest today, a description of their operation provides a good introduction to the subject of stereoplotters
  - ⇒ These instruments create a true three-dimensional stereomodel by projecting transparency images through projector lenses, as illustrated in Fig. 12-1
- ❖ The model is formed by intersections of light rays from corresponding images of the left and right diapositives
- ❖ An operator is able to view the model directly and make measurements on it by intercepting projected rays on a viewing screen (platen)

## 12-2. Classification of Stereoscopic Plotters

- ❖ Instruments of **mechanical projection** or **optical-mechanical projection** also create a true three-dimensional model from which measurements are taken
  - ⇒ Their method of projection, however, is a simulation of direct projection of light rays by mechanical or optical-mechanical means
- ❖ An operator views the diapositives stereoscopically directly through a binocular train
- ❖ **Analytical stereoplotters** form a stereomodel through a purely mathematical procedure which takes place in a computer
- ❖ As with **mechanical plotters**, an operator views the diapositives stereoscopically directly through a binocular train
- ❖ The movements of the stereoscopic images are introduced by servomotors which are under computer control
- ❖ Unlike direct projection or mechanical plotters, these versatile instruments are essentially unlimited in terms of the photographic geometry they can accommodate



## 12-2. Classification of Stereoscopic Plotters

- ❖ Softcopy instruments are the most recent innovation in the design of stereoplotters
- ❖ Fundamentally, **softcopy plotters** operate in the same manner as analytical stereoplotters, except that instead of viewing film (hard-copy) diapositives through binocular optics, scanned (softcopy) photographs are displayed on a computer screen and viewed directly
- ❖ Special viewing systems have been designed which enable the operator to view the left image with the left eye and the right image with the right eye in order to see in stereo
- ❖ Descriptions are general without reference to specific plotters and without comparisons of available instruments
- ❖ Omission of other comparable stereoplotters is not intended to imply any inferiority of these instruments
- ❖ Operator's manuals which outline the details of each of the different instruments are provided by the manufacturers
- ❖ Comprehension of the principles presented in this chapter should provide the background necessary for understanding these manuals

# **PART I**

# **DIRECT OPTICAL PROJECTION STEREOPLOTTERS**

## 12-3. Components

- ❖ The principal components of a typical direct optical projection stereoplotter are illustrated in the schematic diagram of Fig. 12-2
- ❖ The numbered parts are the :
  - (1) *main frame*, which supports the projectors rigidly in place, thereby maintaining orientation of a stereomodel over long periods
  - (2) *reference table*, a large smooth surface which serves as the vertical datum to which model elevations are referenced and which also provides the surface upon which the manuscript map is compiled
  - (3) *tracing table*, to which the platen and tracing pencil are attached

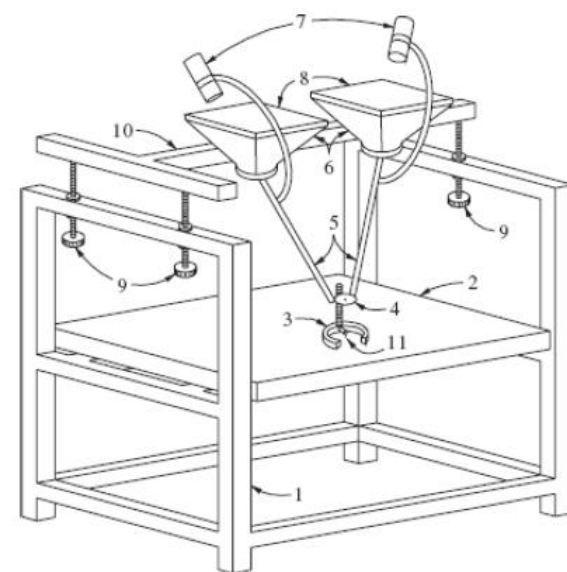

Figure 12-2. Principal components of a typical direct optical projection stereoplotter.

## 12-3. Components

❖ The numbered parts are the (continued) :

- (4) *platen*, the viewing screen which also contains the reference mark
- (5) *guide rods*, which drive the illumination lamps, causing projected rays to be illuminated on the platen regardless of the area of the stereomodel being viewed
- (6) *projectors*
- (7) *illumination lamps*
- (8) *diapositives*
- (9) *leveling screws*, which may be used to tilt the projectors in absolute orientation
- (10) *projector bar*, to which the projectors are attached
- (11) *tracing pencil*, which is located vertically beneath the reference mark on the platen

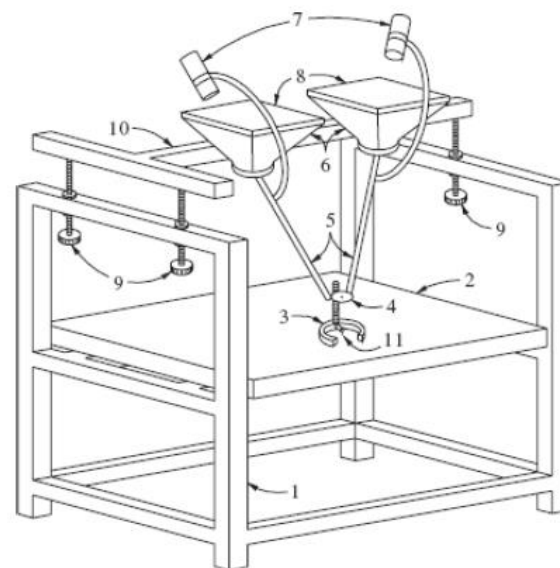

Figure 12-2. Principal components of a typical direct optical projection stereoplotter.

## 12-4. Projection Systems

- ❖ In the projection systems of direct optical projection stereoplotters, diapositives of a stereopair are placed in projectors and illuminated from above
- ❖ Light rays are projected through the projector objective lenses and intercepted below on the reflecting surface of the platen
- ❖ The projection systems of this type of stereoplotter require that the instruments be operated in a dark room
- ❖ **Stereoplotter projectors** are similar to ordinary slide projectors, differing primarily in their optical precision, physical size, and capability of adjustment in angular attitude relative to one another
- ❖ Since projection takes place through an objective lens, the lens formula, Eq. (2-4), must be satisfied in order to obtain a sharply focused stereomodel
 
$$\frac{1}{o} + \frac{1}{i} = \frac{1}{f} \quad (2-4)$$
- ❖ In terms of the stereoplotter symbols of Fig. 12-1b, the lens formula is expressed as
 
$$\frac{1}{f'} = \frac{1}{p} + \frac{1}{h} \quad (12-1)$$

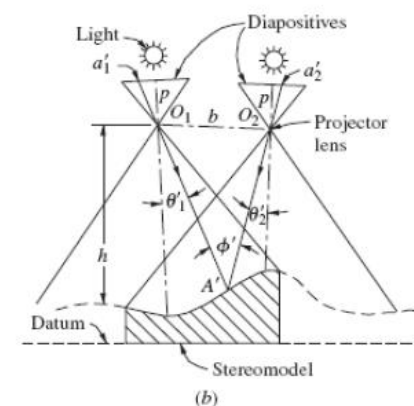

Figure 12-1. Fundamental concept of stereoscopic plotting instrument design.  
(b) Stereoscopic plotting instrument.

## 12-4. Projection Systems

$$\frac{1}{f'} = \frac{1}{p} + \frac{1}{h} \quad (12-1)$$

- ❖ In Eq. (12-1),  $p$  is the *principal distance* of the projectors (distance from diapositive image plane to upper nodal point of the projector lens),  $h$  is the **projection distance** (distance from lower nodal point of the objective lens to the plane of optimum focus), and  $f'$  is the **focal length** of the projector objective lens
- ❖ To obtain a clear stereomodel, intersections of projected corresponding rays must occur at a projection distance within the range of the *depth of field* of the projector lens

## 12-4. Projection Systems

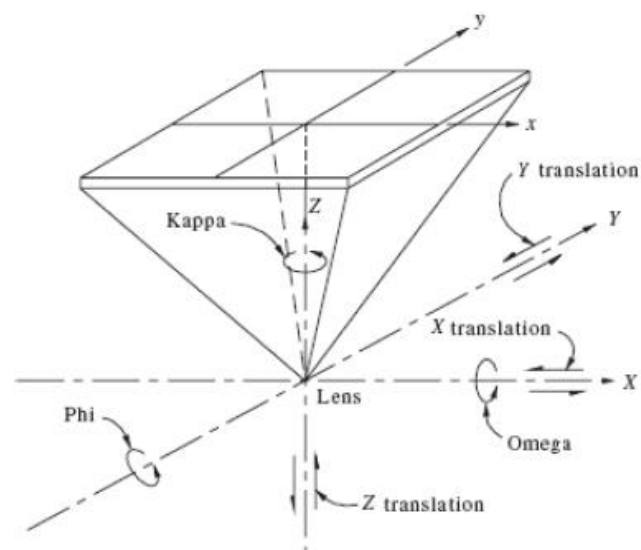

Figure 12-3. The six basic projector motions.

- ❖ To recreate the relative angular relationship of two photographs exactly as they were at the instants of their exposures (a process described in Sec. 12-8), it is necessary that the projectors have rotational and translational movement capabilities
- ❖ These motions, six in number for each projector, are illustrated in Fig. 12-3
- ❖ Three of the movements are angular rotations about each of three mutually perpendicular axes:  $x$  rotation, called *omega*;  $y$  rotation, called *phi*; and  $z$  rotation, called *kappa*
- ❖ The origin of the axis system about which the rotations take place is at the projector lens, with the  $x$  axis being parallel to the projector bar

## 12-4. Projection Systems

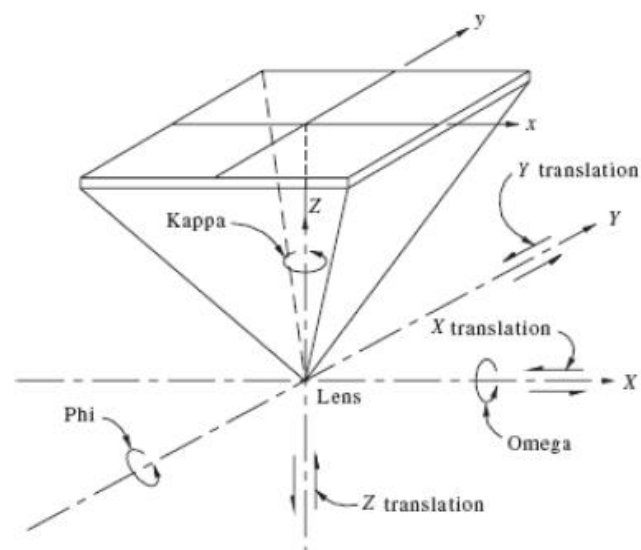

Figure 12-3. The six basic projector motions.

- ❖ To recreate the relative angular relationship of two photographs exactly as they were at the instants of their exposures (a process described in Sec. 12-8), it is necessary that the projectors have rotational and translational movement capabilities
- ❖ These motions, six in number for each projector, are illustrated in Fig. 12-3
- ❖ The other three movements are linear translations along each of the three axes
- ❖ In general, projectors of direct optical projection stereoplotters have all three angular rotations
  - ⇒ however, they do not necessarily have all three linear translations
- ❖ As a minimum, though, they must have the  $x$  translation for changing the spacing between projectors



## 12-4. Projection Systems

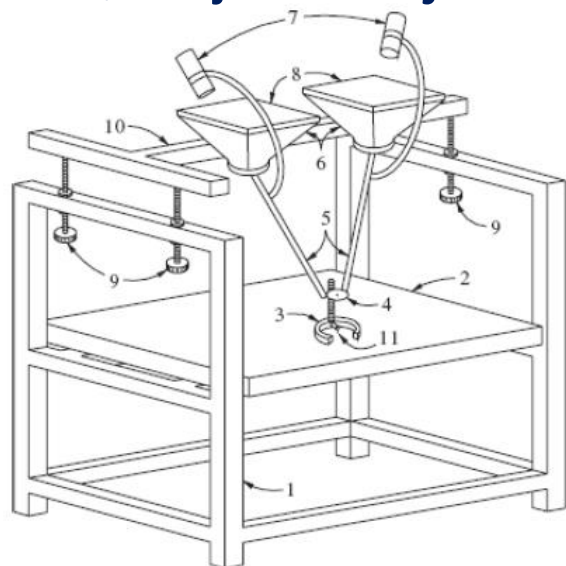

Figure 12-2. Principal components of a typical direct optical projection stereoplotter.

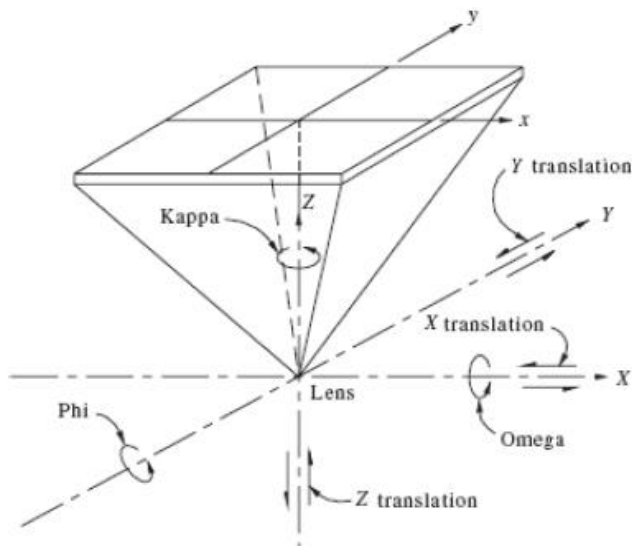

Figure 12-3. The six basic projector motions.

- ❖ Projectors of the type illustrated in Fig. 12-2 illuminate only a small area of the diapositive at a time
- ❖ This type of illumination system consists of a small, narrowangle light source which illuminates a circular area on the diapositive approximately 4 cm in diameter
- ❖ When projected through the objective lens, an area slightly larger than the platen is illuminated in the model area
- ❖ Driven by means of guide rods, the lamps swing above the diapositives, following the platen and illuminating it as it moves about the stereomodel

## 12-5. Viewing and Tracing Systems

- ❖ The function of the viewing system of a stereoplotter is to enable the operator to view the stereomodel three-dimensionally
  - ❖ Stereoviewing is made possible by forcing the left eye to view only the overlap area of the left photo while the right eye simultaneously sees only the overlap area of the right photo
- ❖ The different stereoviewing systems used in direct optical projection plotters are :
    - (1) the *anaglyphic* system
    - (2) the *stereo-image alternator* (SIA)
    - (3) the *polarized-platen viewing* (PPV) system
- ❖ The **anaglyphic system** uses filters of complementary colors, usually red and cyan (blue-green), to separate the left and right projections
  - ❖ Assume that a cyan filter is placed over the light source of the left projector while a red filter is placed over the right
  - ❖ Then, if the operator views the projected images while wearing a pair of spectacles having cyan glass over the left eye and red glass over the right eye, the stereomodel can be seen in three dimensions

## 12-5. Viewing and Tracing Systems

- ❖ The **SIA system** uses synchronized shutters to achieve stereoviewing, and a shutter is placed in front of each projector lens
  - ⇒ a pair of eyepiece shutters, through which the operator must look, is situated in front of the platen
- ❖ The shutters are synchronized so that the left projector and left eyepiece shutters are open simultaneously while the right projector and right eyepiece shutters are closed
- ❖ An operator therefore sees only left projector images with the left eye and right projector images with the right eye
- ❖ The shutters rotate at a rapid rate so that the operator is unaware of any discontinuity in the projection
- ❖ The **PPV system** operates similarly to the anaglyphic system except that polarizing filters are used instead of colored filters
- ❖ Filters of orthogonal polarity are placed in front of the left and right projectors, and the operator wears a pair of spectacles with corresponding filters on the left and right
- ❖ In contrast to the anaglyphic system, the **SIA** and **PPV** systems both cause much less light loss, and both permit the use of color diapositives

## 12-5. Viewing and Tracing Systems

- ❖ A system for making precise measurements of the stereomodel is essential to every stereoplotter
- ❖ Measurements may be recorded as direct tracings of planimetric features and contours of elevation, or they may be taken as **X**, **Y**, and **Z** model coordinates
- ❖ One of the principal elements of the measuring system of a direct optical projection stereoplotter is a tracing table
- ❖ The platen (see Fig. 12-2), which can be raised or lowered, contains a reference mark in its center, usually a tiny speck of light
- ❖ The reference mark appears to float above the stereomodel if the platen is above the terrain  
⇒ hence it is called the floating mark
- ❖ Vertical movement of the platen is geared to a dial, and by varying gear combinations the dial can be made to display elevations directly in meters or feet for varying model scales

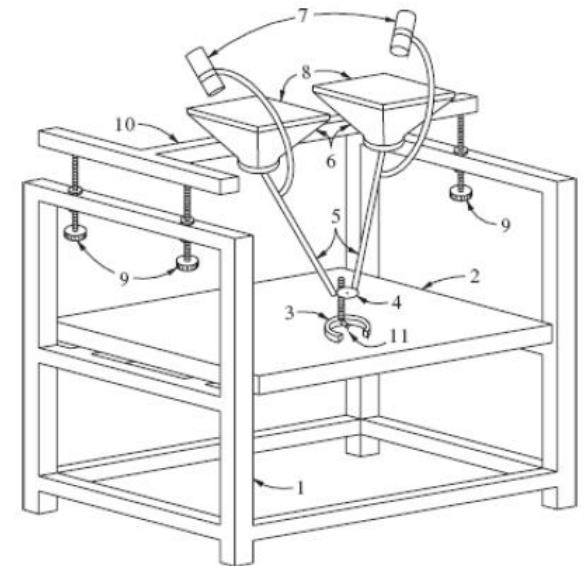

Figure 12-2. Principal components of a typical direct optical projection stereoplotter.

## 12-5. Viewing and Tracing Systems

- ❖ A manuscript map, preferably of stable base material, is placed on top of the reference table  $\Rightarrow$  The tracing table rests on the manuscript and is moved about manually in the  $X$  and  $Y$  directions
- ❖ To plot the position of any point, the platen is adjusted in  $X, Y$ , and  $Z$  until the floating mark appears to rest exactly on the desired point in the model
- ❖ A pencil point which is vertically beneath the floating mark is then lowered to record the planimetric position of the point on the map, and its elevation is read directly from the dial
- ❖ To trace a planimetric feature such as a creek, the pencil is lowered to the map and the tracing table is moved in the  $XY$  plane while the platen is moved up or down to keep the floating mark in contact with the stream  $\Rightarrow$  The pencil thereby records a continuous trace of the feature
- ❖ Contours of elevation may also be traced by locking the dial at the elevation of the desired contour and then moving the tracing table about, keeping the floating mark in contact with the terrain  $\Rightarrow$  Tracing contours with a stereoplotter is a skill that takes years of practice to master

## 12-6. Interior Orientation

- ❖ *Interior orientation*, includes preparations necessary to recreate the geometry of the projected rays to duplicate exactly the geometry of the original photos
  - ⇒ This is necessary to obtain a true stereomodel
  - ⇒ Procedures involved in interior orientation are : (1) preparation of diapositives, (2) compensation for image distortions, (3) centering of diapositives in the projectors, (4) setting off the proper principal distance in the projectors

- ❖ Diapositives are transparencies prepared on optically flat glass for the stereoplotter of Fig. 12-2
- ❖ They are made by direct contact printing so their principal distances will be exactly equal to the focal length of the taking camera
- ❖ Contact printing creates true geometry as long as the principal distances of the projectors are set equal to the focal length of the taking camera

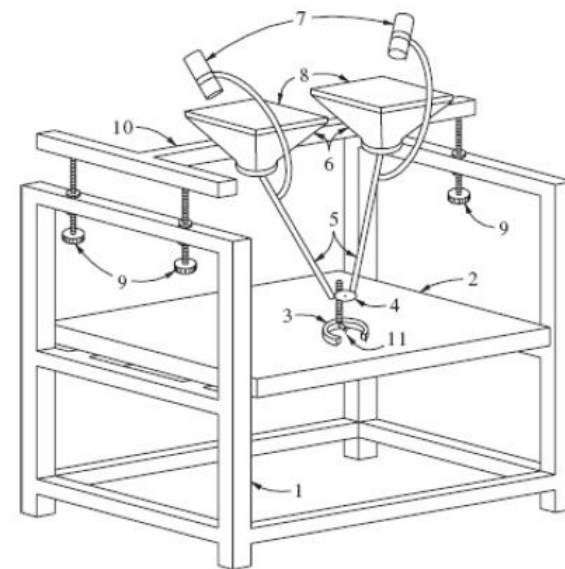

Figure 12-2. Principal components of a typical direct optical projection stereoplotter.

## 12-6. Interior Orientation

- ❖ In **direct optical projection plotters**, compensation for symmetric radial distortion of the lens of the taking camera may be accomplished in one of the following three ways :
  - (1) elimination of the distortion with a "correction plate"
  - (2) varying the projector principal distance by means of a cam
  - (3) use of a projector lens whose distortion characteristics negate the camera's distortion
- ❖ Each diapositive must be centered in its projector so that the principal point is on the optical axis of the projector lens
- ❖ Although this problem is solved slightly differently for each instrument, it is basically done by aligning fiducial marks of the diapositive with four calibrated collimation marks whose intersection locates the optical axis of the projector
- ❖ The final step in interior orientation is to set the diapositive principal distance on the projectors
- ❖ The principal distance is adjusted by either graduated screws or a graduated ring to raise or lower the diapositive image plane

## 12-7. Relative Orientation

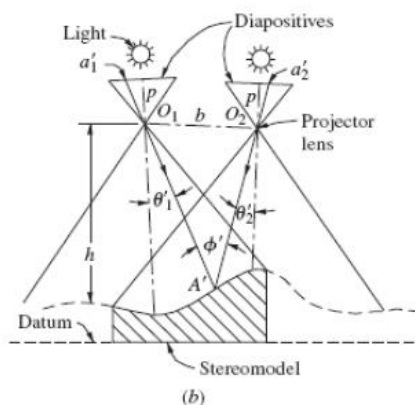
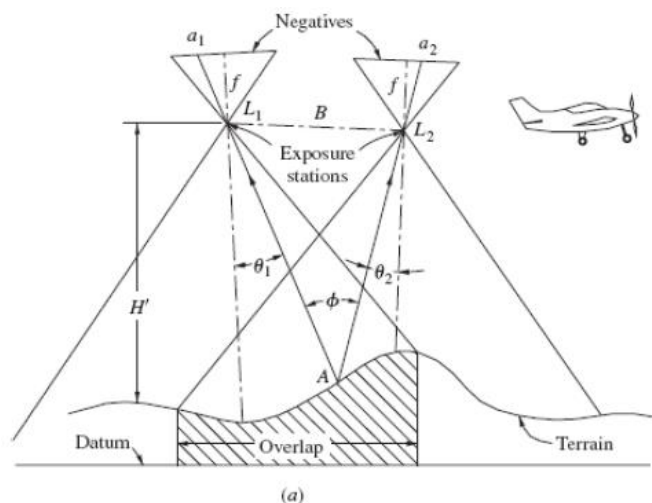

Figure 12-1. Fundamental concept of stereoscopic plotting instrument design. (a) Aerial photography; (b) Stereoscopic plotting instrument.

- ❖ Imagine the camera frozen in space at the instants of exposure of two photographs of a stereopair
- ❖ The two negatives in the camera would then bear a definite position and attitude relationship relative to each other
- ❖ In relative orientation, this relative position and attitude relationship is recreated for the two diapositives by means of movements imparted to the projectors
- ❖ The condition that is fulfilled in relative orientation is that each model point and the two projection centers form a plane in miniature just like the plane that existed for the corresponding ground point and the two exposure stations
  - ⇒ This condition is illustrated by corresponding planes  $A'O_1O_2$  and  $AL_1L_2$  of Fig. 12-1
  - ⇒ Also, parallax angle  $\phi'$  for any point of the stereomodel of Fig. 12-1 must equal the point's original parallax angle  $\phi$



## 12-7. Relative Orientation

- ❖ The implication of the foregoing condition of **relative orientation** is that projected rays of all corresponding points on the left and right diapositives must intersect at a point, and this is the basis of the systematic relative orientation procedures described below
- ❖ Since relative orientation is unknown at the start, the two projectors are **first** positioned relative to each other by estimation
- ❖ **Usually**, if near-vertical photography is being used, the projectors are set so that the diapositives are nearly level and so that their **X** axes lie along a common line
- ❖ **Also**, the projectors are adjusted so that their **Y** and **Z** settings (distances from the projector bar in the **Y** and **Z** directions) are equal
- ❖ **Then**, by an iterative procedure involving incremental projector adjustments while creating clear stereo views at an arrangement of spots in the overlap area, the projectors eventually become properly aligned
- ❖ When **finished**, the projectors are in the same relative orientation as the camera stations were when the photography was acquired
- ❖ The operator can then "roam" about the overlap area and see the model comfortably in three dimensions

## 12-8. Absolute Orientation

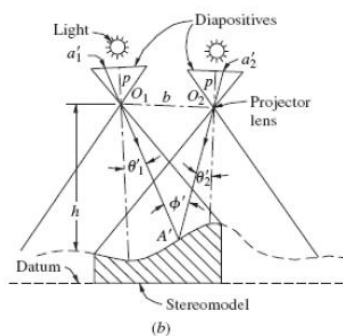
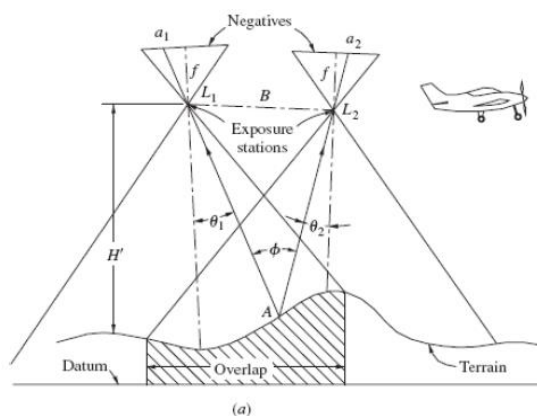

Figure 12-1. Fundamental concept of stereoscopic plotting instrument design.

(a) Aerial photography; (b)

Stereoscopic plotting instrument.

- ❖ Equating these similar triangles, model scale may be expressed as

$$S_m = \frac{b}{B} = \frac{h}{H'} \quad (12-2)$$

- ❖ After relative orientation is completed, a true three-dimensional model of the terrain exists
- ❖ Although the horizontal and vertical scales of the model are equal, that scale is unknown and must be fixed at the desired value
- ❖ Also the model is not yet level with respect to a vertical datum
- ❖ Selecting model scale and fixing the model at that scale, and leveling the model are the purposes of absolute orientation
- ❖ Model scale is fixed within certain limits by the scale of the photography and by the characteristics of the particular stereoplotter
- ❖ By comparing the geometry of Fig. 12-1a and b, model scale is seen to be the ratio of the sizes of triangles  $AL_1L_2$  and  $A'O_1O_2$

## 12-8. Absolute Orientation

$$S_m = \frac{b}{B} = \frac{h}{H'} \quad (12-2)$$

- ❖ In Eq. (12-2),  $S_m$  is model scale,  $b$  is the model air base,  $B$  is the photographic air base,  $h$  is plotter projection distance, and  $H'$  is the flying height above ground
- ❖ From Eq. (12-2) it can be seen that model scale is directly proportional to model air base
- ❖ Thus by varying the model air base, the model scale can be set to the desired value  
⇒ However, due to limits on the range of  $h$  values, there will be corresponding limits on the range of the model air base,  $b$

## 12-8. Absolute Orientation

- ❖ If a preliminary model base is calculated from Eq. (12-2) and the projectors are set accordingly, then after relative orientation the stereomodel will be near the required scale
- ❖ As defined by Eq. (12-2) and shown in Fig. 12-4, model scale is changed by varying the model base

$$S_m = \frac{b}{B} = \frac{h}{H'} \quad (12-2)$$

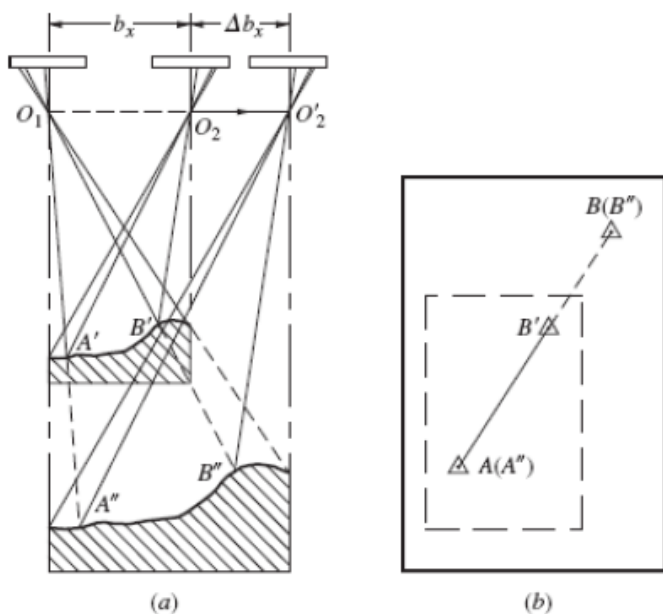

Figure 12-4. Changing model scale by adjusting model base. (a) Cross-sectional view; (b) plan view.

- ❖ If the  $Y$  and  $Z$  settings of the two projectors are equal, then model base is composed only of an  $X$  component called  $b_x$ , and model scale is varied by simply changing the model base by  $\Delta b_x$ , as shown in Fig. 12-4a

## 12-8. Absolute Orientation

- ❖ A minimum of two horizontal control points is required to scale a stereomodel. These points are plotted at adopted model scale on the manuscript map as points **A** and **B** of Fig. 12-4b
- ❖ The manuscript is then positioned under the model, and with the floating mark set on one model point, such as **A'**, the manuscript is moved until map point **A** is directly under the plotting pencil  $\Rightarrow$  The floating mark is then set on model point **B'**

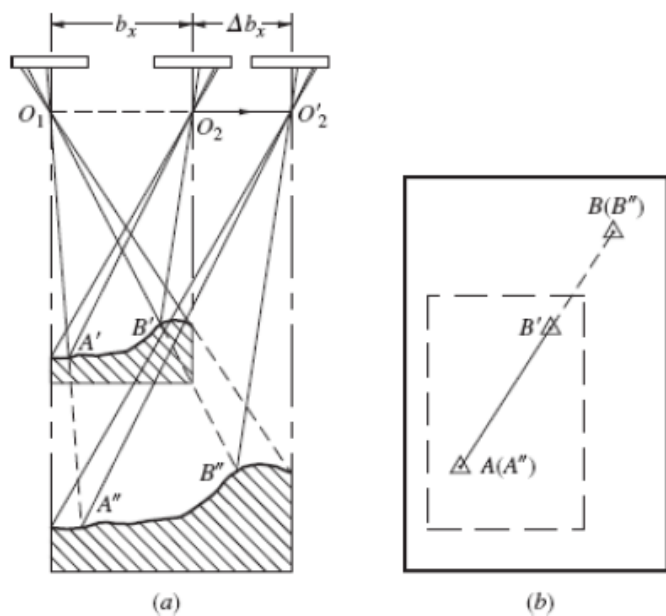

Figure 12-4. Changing model scale by adjusting model base. (a) Cross-sectional view; (b) plan view.

- ❖ While the manuscript is held firmly with a fingertip at point **A**, it is rotated until map line **AB** is collinear with model line **A'B'**
- ❖ If model line **A'B'** is shorter than map line **AB**, as is the case in Fig. 12-4b, model scale is too small and must be increased by increasing the model base until new model line **A''B''** is equal in length to map line **AB**
- ❖ The model base may be set to the required value by trial and error, or  $\Delta b_x$  may be calculated directly from

$$\Delta b_x = b_x \left( \frac{AB}{A'B'} - 1 \right) \quad (12-3)$$

## 12-8. Absolute Orientation

$$\Delta b_x = b_x \left( \frac{AB}{A'B'} - 1 \right) \quad (12-3)$$

- ❖ In Eq. (12-3),  $AB$  and  $A'B'$  are scaled from the manuscript in any convenient units
- ❖ If the algebraic sign of  $\Delta b_x$  is negative, model scale is too large and  $b$  must be reduced by  $\Delta b_x$
- ❖ Once the model is scaled, it is recommended that a third horizontal control point be checked to guard against possible mistakes
- ❖ The final step in absolute orientation is to level the model
- ❖ This procedure requires a minimum of three vertical control points distributed in the model so that they form a large triangle
- ❖ As a practical matter, four points, one near each corner of the model, should be used
- ❖ A fifth point near the center of the model is also desirable

## 12-8. Absolute Orientation

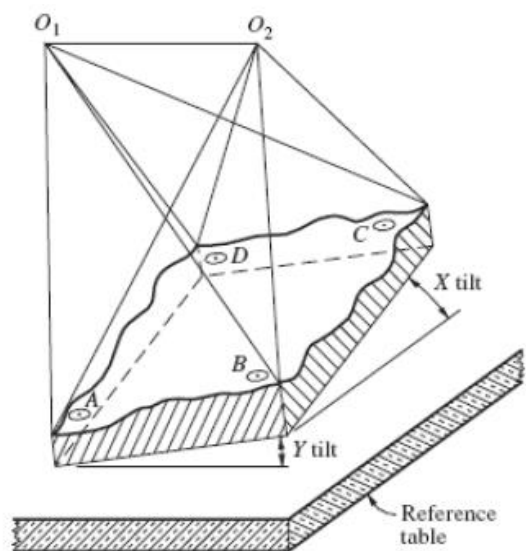

Figure 12-5. Stereomodel that is not level (note X and Y components of tilt).

- ❖ A model with a vertical control point near each corner that has not yet been leveled is shown in Fig. 12-5
- ❖ Note that there are two components of tilt in the model, an  $X$  component (also called  $\Omega$ ) and a  $Y$  component (also called  $\Phi$ )
- ❖ The amount by which the model is out of level in each of these components is determined by reading model elevations of the vertical control points and comparing them with their known values

## 12-8. Absolute Orientation

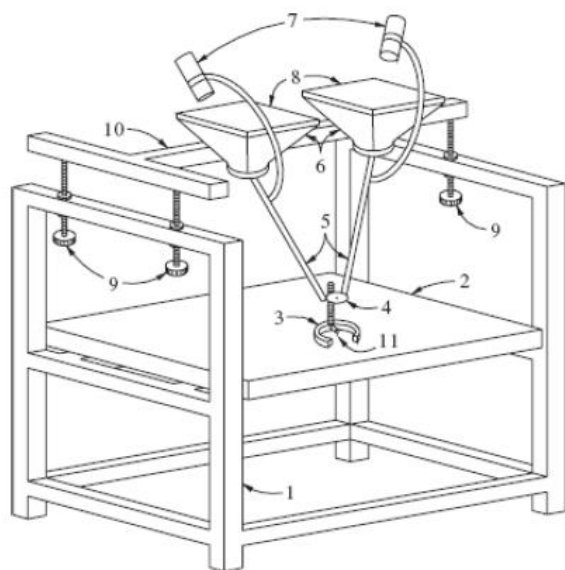

Figure 12-2. Principal components of a typical direct optical projection stereoplotter.

- ❖ With stereoplotters such as that of Fig. 12-2, corrective tilts can be introduced by turning the leveling screws to rotate the projector bar as illustrated in Fig. 12-6
- ❖ After the leveling procedure has been completed, the model will appear as it does in Fig. 12-6b and d

- ❖ There are different methods available for introducing the corrective  $X$  and  $Y$  tilts, depending upon the particular design of the stereoplotter

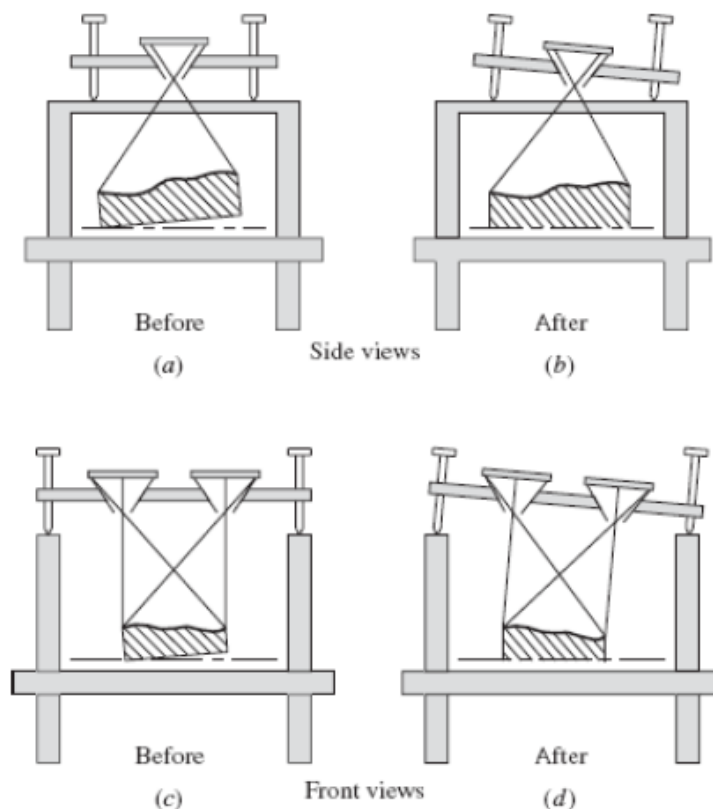

Figure 12-6. (a) and (b) Correcting  $X$  tilt of a model by  $X$  tilt of projector bar. (c) and (d) Correcting  $Y$  tilt of a model by  $Y$  tilt of projector bar.



## 12-8. Absolute Orientation

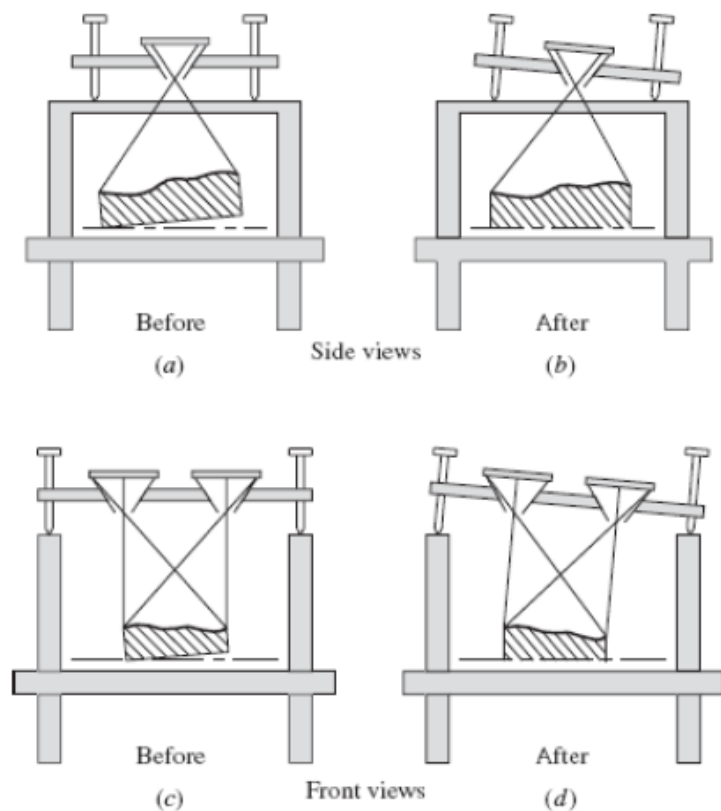

Figure 12-6. (a) and (b) Correcting X tilt of a model by X tilt of projector bar. (c) and (d) Correcting Y tilt of a model by Y tilt of projector bar.

- ❖ The leveling operation will disturb the previously established model scale, especially if large corrective tilts are required
- ❖ Also, it is likely that absolute orientation will slightly upset relative orientation
- ❖ Therefore it is not practical to labor at great lengths with either relative or absolute orientation the first time through
- ❖ Rather, quick orientations should be performed at first, followed by careful refinements the second time through
- ❖ When orientation is completed, the manuscript map should be firmly secured to the reference table in preparation for map compilation

# **PART II**

# **ANALYTICAL PLOTTERS**

## 12-9. Introduction

- ❖ Analytical plotters development was made possible by advances in computers, digital encoders, and servosystems
- ❖ By combining computerized control with precision optical and mechanical components, **analytical plotters** enable exact mathematical calculations to define the nature of the stereomodel
- ❖ They are also easily interfaced with computer-aided drafting (CAD) systems, which facilitates map editing and updates
- ❖ These instruments, with their digital output capability, are ideal for compiling data for use in geographic information systems
- ❖ Because they have no optical or mechanical limitations in the formation of their mathematical models, analytical plotters have great versatility
- ❖ They can handle any type of photography, including vertical, tilted, low oblique, convergent, high oblique, panoramic, and terrestrial photos
- ❖ In addition, they can accommodate photography from any focal-length camera, and in fact they can simultaneously use two photos of different focal lengths to form a model

## 12-9. Introduction

- ❖ In comparison with analog plotters, analytical plotters can provide results of **superior accuracy** for three fundamental reasons

① Because they do not form model points by intersecting projected light rays or mechanical components optical and mechanical errors from these sources are not introduced

② Analytical plotters can effectively correct for any combination of systematic errors caused by camera lens distortions, film shrinkage or expansion, atmospheric refraction, and, if necessary, earth curvature

③ In almost every phase of their operation, they can take advantage of redundant observations and incorporate the method of least squares into the solution of the equations

## 12-9. Introduction

- ❖ The essential capabilities of an analytical plotter are :
  - (1) to precisely measure x and y photo coordinates on both photos of a stereopair
  - (2) to accurately move to defined x and y photo locations
- ⇒ These operations are carried out under direct computer control
  
- ❖ Digital encoders provide the ability to measure x and y photo coordinates, with the output from the encoders being read by the computer
  
- ❖ Servomotors, which respond to signals from the controlling computer, allow the photographs to be moved to the defined locations

## 12-10. System Components and Method of Operation

- ❖ An analytical plotter incorporates a pair of precision comparators which hold the left and right photos of a stereopair
- ❖ Figure 12-7 shows a schematic diagram of a single comparator which employs a lead screw for measurement and movement
- ❖ The plate carrier, which holds the photograph, moves independently in the X and Y directions as the servomotors turn the corresponding lead screws

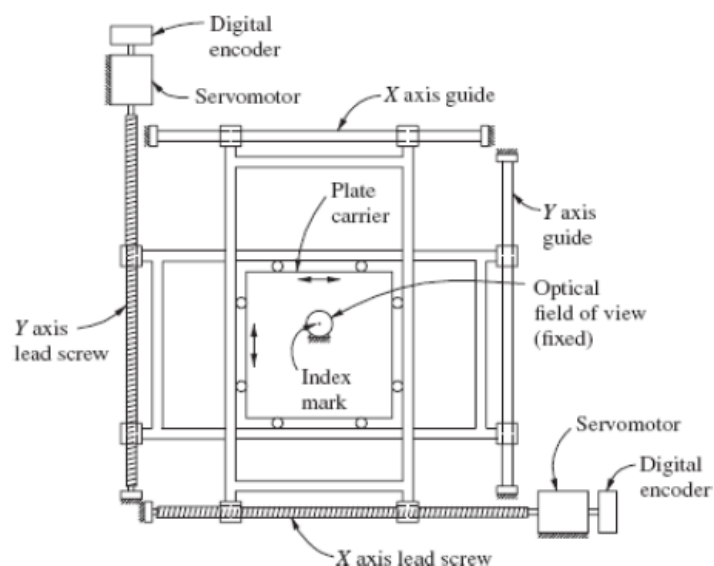

Figure 12-7. Schematic representation of a comparator from an analytical plotter.

- ❖ Digital encoders attached to the shafts of the motors sense the position of a point on the photo relative to an index mark (half mark) which is fixed

## 12-10. System Components and Method of Operation

- ❖ Figure 12-8 illustrates how the primary components of an analytical stereoplotter interact
- ❖ The heart of the system is the *controller computer* which interfaces with the *operator controls*, *servomotors*, *encoders*, and the *CAD computer*

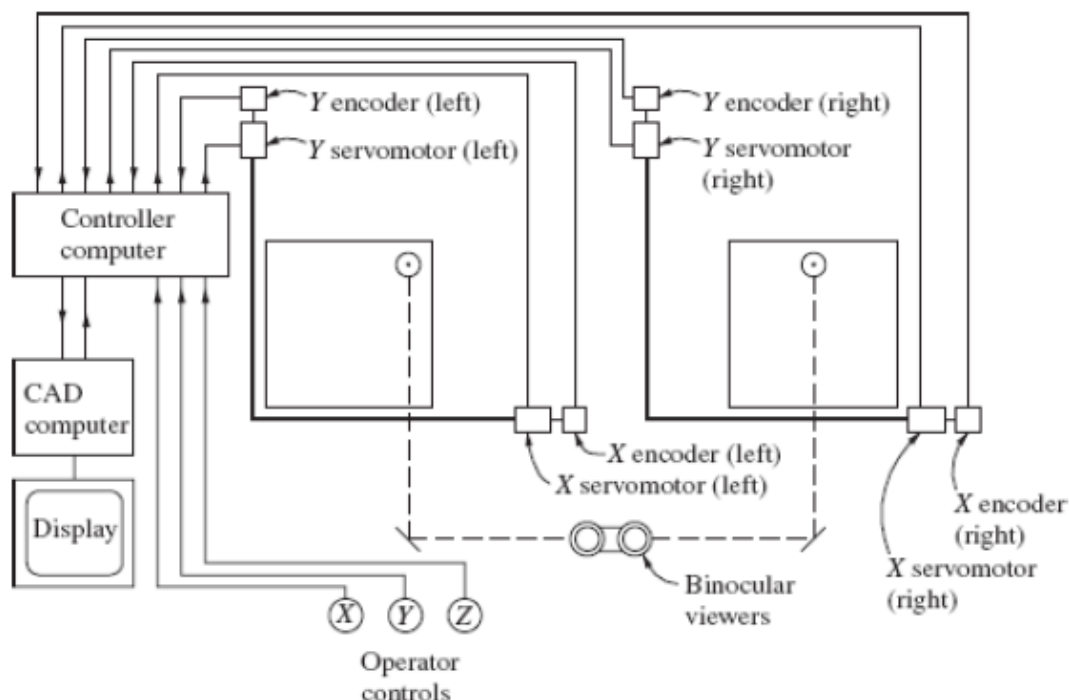

Figure 12-8. Schematic diagram of components and operation of an analytical plotter.

- ❖ The controller computer accepts input from the operator controls and calculates left and right plate positions from these inputs
- ❖ It then operates the servomotors to move the plates, stopping when the encoders indicate that the correct positions have been reached

## 12-10. System Components and Method of Operation

- ❖ Analytical plotters form neither an optical nor a mechanical model, rather, they compute a *mathematical* model based on the principles of analytical photogrammetry
  - ⇒ This mathematical model is established through numerical versions of interior, relative, and absolute orientation
- ❖ Although the exact methods used to accomplish these orientations may vary among instruments, the fundamental approach is the same
- ❖ Typically, the orientation software is a distinct module, separate from the data collection (mapping) software
  - ⇒ This allows flexibility in the choice of available data collection software for a given analytical plotter

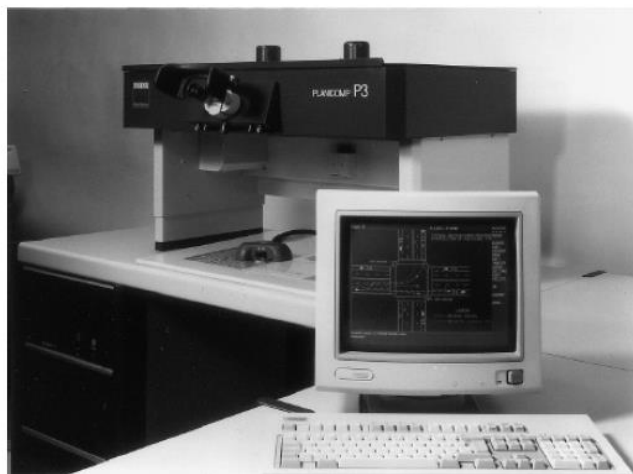

Figure 12-9. Zeiss P-3 analytical plotter. (Courtesy Carl Zeiss, Inc.)



Figure 12-10. Leica SD3000 analytical plotter. (Courtesy LH Systems, LLC.)



## 12-10. System Components and Method of Operation

- ❖ Although the development of the softcopy stereoplotters has reduced the demand for analytical plotters and major manufacturers are no longer producing new plotters they are still widely used
- ❖ Two popular analytical stereoplotters are the Zeiss P-3, and the Leica SD3000, shown in Figs. 12-9 and 12-10, respectively

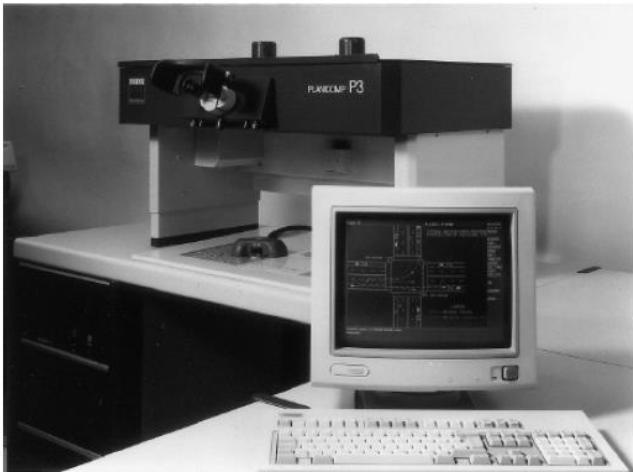

Figure 12-9. Zeiss P-3 analytical plotter. (Courtesy Carl Zeiss, Inc.)



Figure 12-10. Leica SD3000 analytical plotter. (Courtesy LH Systems, LLC.)

## 12-11. Analytical Plotter Orientation

- ❖ As is necessary with all analog stereoplotters, interior, relative, and absolute orientation are also required for analytical plotters prior to going into most modes of operation
- ❖ In all phases of orientation, a dialogue is maintained between operator and instrument
- ❖ The system's computer guides the operator through each of the various steps of operation, calling for data when needed and giving the operator opportunities to make certain decisions
- ❖ Prior to using an analytical plotter, its measuring system should be calibrated using a precise grid plate ⇨ This plate consists of a flat piece of glass upon which an array of fine crosses has been etched
- ❖ The coordinates of the crosses on a high-quality grid plate are known to within 1 or 2  $\mu\text{m}$
- ❖ The grid plate is placed on the plate carrier, and the coordinates of each of the crosses are measured
- ❖ A two-dimensional coordinate transformation is then computed which relates the raw plate coordinates of the analytical plotter to the accurate xy system of the grid plate
- ❖ An analytical plotter should be recalibrated approximately every year as part of routine maintenance or anytime the instrument is moved, to ensure accurate results

## 12-11-1. Interior Orientation

- ❖ Interior orientation consists of :
  - (1) preparation of diapositives
  - (2) compensation for image distortions
  - (3) centering of diapositives
  - (4) setting off the proper principal distance
- ❖ Steps 2 and 4 simply amount to accessing the appropriate lens distortion coefficients and camera focal length from a data file
- ❖ Diapositives used with analytical plotters are typically contact prints made on film transparencies, although some plotters can accommodate paper (opaque) prints
- ❖ The individual diapositives of a stereopair are placed on the left and right plate carriers and held in place by glass covers
- ❖ Centering of the diapositives is accomplished by measuring the  $X$  and  $Y$  plate coordinates (based on the encoders) of the fiducials of each photo
- ❖ This phase of operation is aided by computer-activated servomotors, which automatically drive the measuring mark to the vicinity of the fiducials
- ❖ A fine pointing is then made by the operator

## 12-11-1. Interior Orientation

- ❖ As few as two fiducials can be measured, but more are recommended and up to eight should be measured if they are available, to increase redundancy
- ❖ Individual two-dimensional coordinate transformations are then calculated for the left and right photos
  - ⇒ This establishes the relationship between the  $XY$  plate coordinates and the  $xy$  calibrated fiducial coordinates, and at the same time it compensates for film shrinkage or expansion
- ❖ A choice of coordinate transformations is available, but usually the affine or projective types are used
- ❖ Residuals for this solution will be displayed so that the operator can either accept them or remeasure one or more fiducials
- ❖ When the solution is accepted, the interior orientation parameters are stored in the computer

## 12-11-2. Relative Orientation

- ❖ Relative orientation is achieved by numerical techniques
- ❖ The operator measures the left and right photo coordinates of at least six pass points to provide observations for the least squares relative orientation solution
- ❖ In areas of imagery that contain discrete features such as manhole covers and sidewalk intersections, the operator sets the individual left and right index marks on the images of the feature in each photo to measure their coordinates
- ❖ In open areas such as grass-covered fields, the operator adjusts the floating mark while viewing in stereo until it appears to rest exactly on the ground
- ❖ Once the raw plate coordinates are observed for all pass points, they are transformed to the calibrated fiducial system, and then lens distortion and atmospheric refraction corrections are applied, resulting in refined coordinates

## 12-11-2. Relative Orientation

- ❖ Numerical relative orientation is then calculated, resulting in values for the exterior orientation parameters ( $\omega, \varphi, \kappa, X_L, Y_L, Z_L$ ) for both photos
- ❖ Again the residuals will be displayed, and the operator has the option of discarding certain points, adding others, or accepting the solution
- ❖ When relative orientation is accepted, the orientation parameters are stored in the computer
- ❖ At this point the operation of the analytical plotter changes from a two-dimensional to a three-dimensional mode
- ❖ The  $X, Y,$  and  $Z$  operator controls provide model coordinate input to the controller computer which then drives the plates to the appropriate image locations

## 12-11-3. Absolute Orientation

- ❖ Absolute orientation is commonly achieved by a three-dimensional conformal coordinate transformation
- ❖ While viewing in stereo, the operator places the floating mark on the images of the ground control points which appear in the model and records the **XYZ** model coordinates
- ❖ The computer then accesses a previously established data file which contains the ground coordinates for the control points, thus enabling a three-dimensional conformal coordinate transformation to be calculated
- ❖ For absolute orientation a minimum of two horizontal and three well-distributed vertical control points are required, just as for absolutely orienting analog plotters
- ❖ More than the minimum is recommended, however, so that a least squares solution can be made
- ❖ Once again, residuals are displayed, and the operator has the option of discarding or remeasuring individual points
- ❖ After the solution is accepted, the transformation parameters are stored, the analytical stereoplotter is fully oriented, and it is ready to be used as a three-dimensional mapping tool

## 12-12. Three-Dimensional Operation of Analytical Plotters

- ❖ After the steps of orientation are complete, the parameters from each step are available for real-time control of the plotter
- ❖ The operator supplies input of  $X, Y$ , and  $Z$  ground coordinates through hand (and/or foot) controls, and the instrument responds by calculating theoretical left and right plate coordinates for this ground position
- ❖ The servomotors then move the left and right plates to these coordinates so that the floating mark appears at the corresponding location in the model
- ❖ At first glance, this sequence of operation seems to be out of order
- ❖ Users of analytical plotters often incorrectly assume that their hand control inputs directly move the index marks to positions in the photos and that ground  $XYZ$  coordinates are then computed  
⇒ This confusion may arise due to the real-time nature of plotter operation.



## 12-12. Three-Dimensional Operation of Analytical Plotters

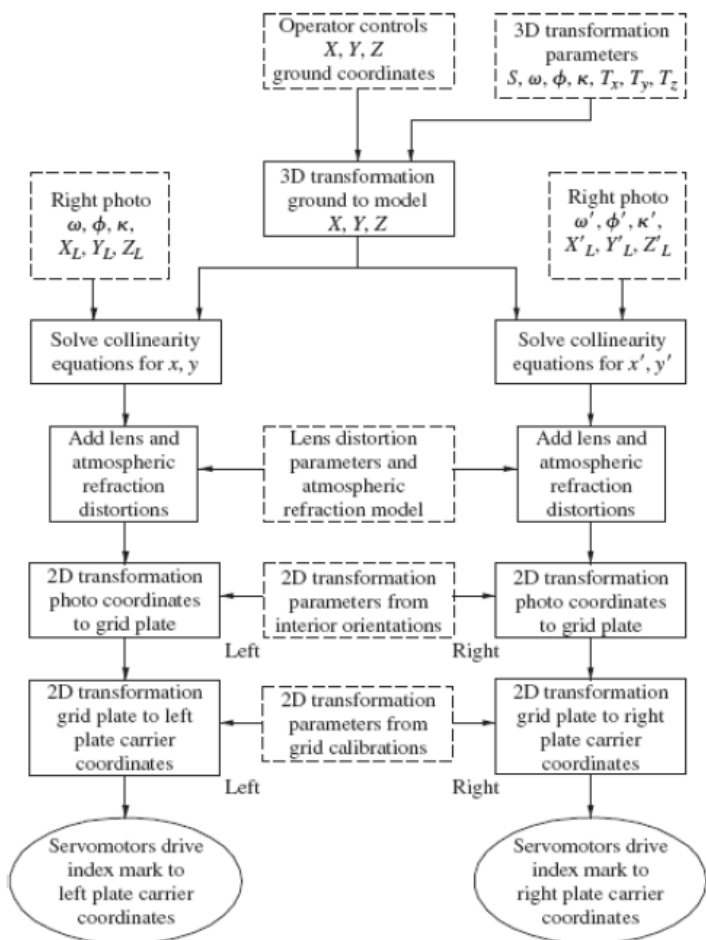
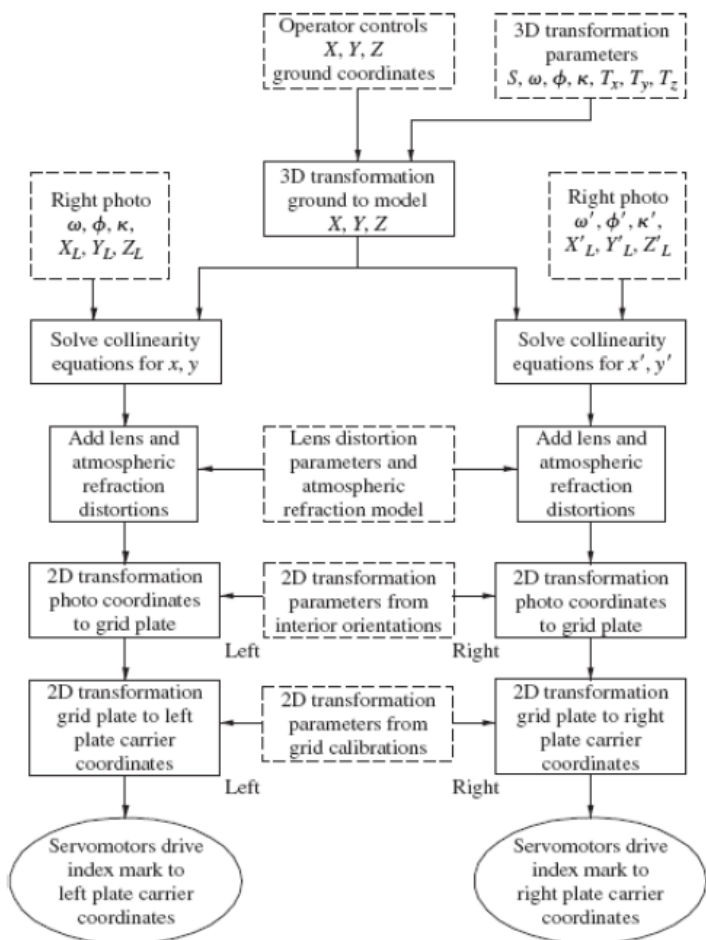

Figure 12-11. Flowchart showing the real-time, three-dimensional operation of an analytical stereoplotter.

- ❖ The top-down flow of this real-time operation is illustrated in Fig. 12-11
- ❖ In this figure, computational steps are indicated with solid boxes, inputs represented with dashed boxes, and instrument movements indicated with ellipses
- ❖ The process begins when the operator adjusts the  $XYZ$  controls which provide the primary inputs
- ❖ The controlling computer then calculates the corresponding  $XYZ$  model coordinates by applying parameters of the three-dimensional conformal coordinate transformation, which was calculated in the absolute orientation step
- ❖ Note that the three-dimensional transformation was computed going from ground system to model

## 12-12. Three-Dimensional Operation of Analytical Plotters



$$x_a = x_o - f \left[ \frac{m_{11}(X_A - X_L) + m_{12}(Y_A - Y_L) + m_{13}(Z_A - Z_L)}{m_{31}(X_A - X_L) + m_{32}(Y_A - Y_L) + m_{33}(Z_A - Z_L)} \right] \quad (11-1)$$

$$y_a = y_o - f \left[ \frac{m_{21}(X_A - X_L) + m_{22}(Y_A - Y_L) + m_{23}(Z_A - Z_L)}{m_{31}(X_A - X_L) + m_{32}(Y_A - Y_L) + m_{33}(Z_A - Z_L)} \right] \quad (11-2)$$

- ❖ After the **XYZ** model coordinates have been computed, the computer solves the collinearity equations [see Eqs. (11-1) and (11-2)] for  $x$  and  $y$  coordinates on the left photo and  $x'$  and  $y'$  coordinates on the right
- ❖ The calculations are made using the **XYZ** model coordinates as well as the exterior orientation parameters  $\omega, \varphi, \kappa, X_L, Y_L, Z_L$  of the left photo and  $\omega', \varphi', \kappa', X'_L, Y'_L, Z'_L$  of the right

Figure 12-11. Flowchart showing the real-time, three-dimensional operation of an analytical stereoplottor.

## 12-12. Three-Dimensional Operation of Analytical Plotters

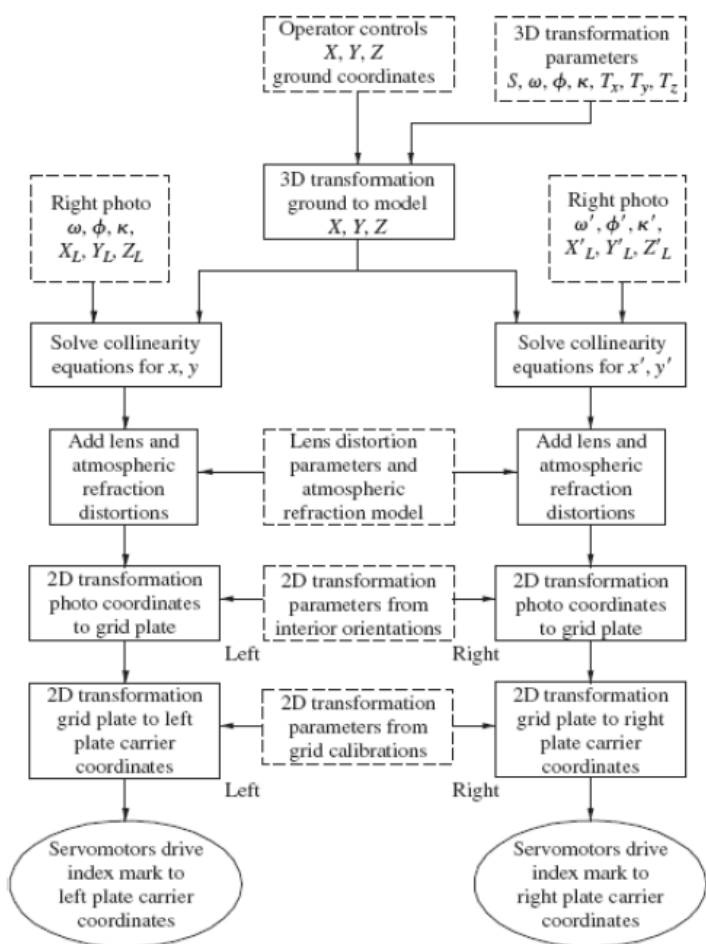

Figure 12-11. Flowchart showing the real-time, three-dimensional operation of an analytical stereoplottedter.

- ❖ The photo coordinates directly computed from the collinearity equations contain no distortions and may therefore be considered ideal coordinates
- ❖ The actual images in the photographs, however, do not occupy these ideal positions due to lens distortion and atmospheric refraction
- ❖ Therefore, when the servomotors move the plates, in order for the actual images in the photos to correctly coincide with the index marks in the binoculars, distortions must be added to the ideal coordinates computed by the collinearity equations

## 12-12. Three-Dimensional Operation of Analytical Plotters

- ❖ The next step is to transform from the photo coordinate system to the calibrated grid plate coordinate system
  - ⇒ This calculation is based on the two-dimensional coordinate transformation parameters which were computed during interior orientation
- ❖ The final step is to transform from grid plate coordinates to the plate carrier coordinate system
  - ⇒ This calculation relies on the two-dimensional coordinate transformation parameters which were computed during grid plate calibration
- ❖ With the plate carrier coordinates known for both photographs, the servomotors are instructed to drive the left and right index marks to these locations
- ❖ All these calculations can be performed in a fraction of a millisecond on a modern computer, giving a real-time response
- ❖ The only lag in the system is due to the finite speed of the servomotors
  - ⇒ However, unless fast, abrupt movements are made with the operator controls, the entire process happens smoothly and with instantaneous response

## 12-12. Three-Dimensional Operation of Analytical Plotters

- ❖ The *XYZ* stereoplotter controls are directly linked to the CAD system inputs
- ❖ The operator could, in fact, draw on the CAD system using these controls without looking into the plotter, although the drawn entities would have no relationship to the ground if this were done
- ❖ By looking into the plotter, the operator can see the movement of the floating mark as it responds to *XYZ* input
- ❖ The operator guides the floating mark in *X*, *Y*, and *Z* until it appears to rest directly on the feature of interest
- ❖ At that point, the final position of the operator controls defines the *XYZ* ground position of the feature, and it is then recorded into the CAD system

## 12-13. Modes of Use of Analytical Plotters

- ❖ The modes of use of analytical plotters vary only slightly with the different instruments
  - ⇒ Generally all can perform planimetric and topographic mapping
  - ⇒ In this case the operator simply traces out features and contours by keeping the floating mark in contact with each feature
- ❖ The ground coordinates from the operator controls are directly transmitted to the CAD computer for subsequent off-line editing and plotting, or for the development of digital elevation models
- ❖ "Layered information" needed for the databases of geographic information systems can also be conveniently compiled and stored

## 12-13. Modes of Use of Analytical Plotters

- ❖ Analytical plotters can also be operated in a profiling mode
  - ⇒ In this operation  $X, Y$ , and  $Z$  coordinates can be measured along predetermined lines in the model
- ❖ The locations and directions of desired profile lines can be input to the computer in terms of  $XY$  ground coordinates, and the machine will automatically drive the measuring mark to the corresponding locations while an operator monitors the floating mark to keep it in contact with the ground
  - ⇒ The  $XYZ$  plotter output is continuously recorded by the CAD computer
- ❖ Profile data can be used directly for various engineering applications such as investigating earthwork quantities along proposed highway centerlines, or they can be used to generate terrain elevation data for subsequent digital orthophoto production

## 12-13. Modes of Use of Analytical Plotters

- ❖ Another common application of analytical plotters is in **aerotriangulation**
  - ⇒ Here various modes of operation are possible, from independent model triangulation to simultaneous bundle adjustment
- ❖ When the aerotriangulation is completed, the **diapositives** can be used in other stereoplotters or photogrammetric scanners, or they can be reset in the analytical plotter based upon the now available ground control information
  - ⇒ As a result of aerotriangulation, the parameters of relative and absolute orientation become known
- ❖ Analytical plotters have a "**reset**" **capability** which enables reading in these known parameters, whereupon an instantaneous relative and absolute orientation can be achieved automatically, thus bypassing the measurements otherwise needed to determine those two steps
- ❖ In fact, if for any reason a model that was once set should need to be reset to obtain additional data, the orientation parameters from the first setting can be recalled and the system will automatically perform relative and absolute orientation
- ❖ Anytime photos are moved, however, interior orientations must be redone since the positions of the photographs on the plate carriers will have changed



## 12-13. Modes of Use of Analytical Plotters

- ❖ Analytical plotters can also be used simply as **monocomparators** or **stereocomparators**, where image coordinates are measured and recorded for use in aerotriangulation
- ❖ Many analytical stereoplotters contain a software module which performs aerotriangulation
- ❖ Alternatively, photo coordinate data can be recorded in a computer file in various formats, suitable for any of several commercially available aerotriangulation software programs

# **PART III**

# **SOFTCOPY PLOTTERS**

## 12-14. Introduction

- ❖ The latest stage in the evolution of stereoplotters is that of **softcopy plotters**
- ❖ The fundamental operation of a softcopy plotter is the same as that of an analytical plotter except that instead of employing servomotors and encoders for point measurement, softcopy systems rely on digital imagery
- ❖ Softcopy plotters can perform all the operations of an analytical plotter and, due to their design, can perform a wealth of digital image processing routines as well
- ❖ Softcopy stereoplotters have had a tremendous impact on the practice of photogrammetry
- ❖ By replacing costly optical and mechanical components with digital display manipulation, **softcopy plotters** have become less expensive and more versatile than analytical plotters
- ❖ The core of a softcopy plotter is a set of computer software modules that perform various photogrammetric tasks
- ❖ Software is the distinguishing characteristic, while associated computer hardware may be purchased "off the shelf" from a variety of vendors

## 12-14. Introduction

- ❖ Besides the software, another essential component of a softcopy plotter is a computer with a high-resolution graphics display
- ❖ The computer must be capable of manipulating large digital images efficiently and must be able to display left and right photos of a stereopair simultaneously or nearly so
- ❖ At the same time, a special configuration is required so that the operator's left eye views only the left photo and the right eye views only the right photo
- ❖ Manual use of a softcopy plotter is most similar to that of an analytical stereoplotter
- ❖ Orientations can be performed by placing the measuring mark (a single pixel or small pattern of pixels on the display) on necessary points, followed by analytical calculations being performed to compute the orientation
- ❖ Once oriented, the softcopy plotter can be used in the three-dimensional mode to measure (digitize) topographic features

## 12-14. Introduction

- ❖ In addition to the manual uses available with softcopy plotters, these systems offer many automatic features not found on analytical plotters
- ❖ One of the most useful automatic capabilities is the ability to perform routine point measurement by computer processing, requiring little or no operator input
- ❖ This capability can significantly speed up the process of orienting the plotter, as well as assist in collecting digital elevation model information, profiles, and cross-sections
- ❖ Another convenience offered by softcopy plotters is *vector superimposition*, in which topographic map features (lines, points, etc.) are superimposed on the digital photos as they are being digitized
- ❖ This capability, also found on a few analytical stereoplotters, allows operators to keep their gaze in one place rather than constantly moving back and forth from photograph display to CAD display

## 12-15. System Hardware

- ❖ The fundamental hardware requirement for a softcopy stereoplotter is a high-performance computer workstation with advanced graphics capability
- ❖ The computer must have not only substantial processing speed, but also large amounts of random access memory and mass storage (hard disk space)
- ❖ Many systems employ **multiple processors to increase computational speed**
  - ⇒ This high speed and the large memory capacity are necessary because digital image files used in softcopy plotters may be several hundred megabytes or more
  - ⇒ In addition, some form of archival storage such as optical disks is required for offline storage of digital images
- ❖ The system also requires operator controls for  **$X$ ,  $Y$ , and  $Z$**  position within the stereomodel
- ❖ On a softcopy system, the  **$X$**  and  **$Y$**  controls are usually implemented as some type of computer "mouse," while the  **$Z$**  control is typically a small wheel which can be rotated by the operator's thumb

## 12-15. System Hardware

- ❖ For the computer to serve as a stereo workstation, additional hardware is required to enable the operator to see the left image with the left eye and the right image with the right eye
- ❖ Various approaches are available to provide stereoviewing capability, such as polarizing filters and alternating shutters
- ❖ In the polarizing filter approach, a computer, display system is configured so that light from the left image and light from the right image are orthogonally polarized

- ❖ Meanwhile, the operator wears a simple pair of spectacles consisting of orthogonally polarized filters
- ❖ Figure 12-12 illustrates a stereo display configuration for the polarizing filter approach

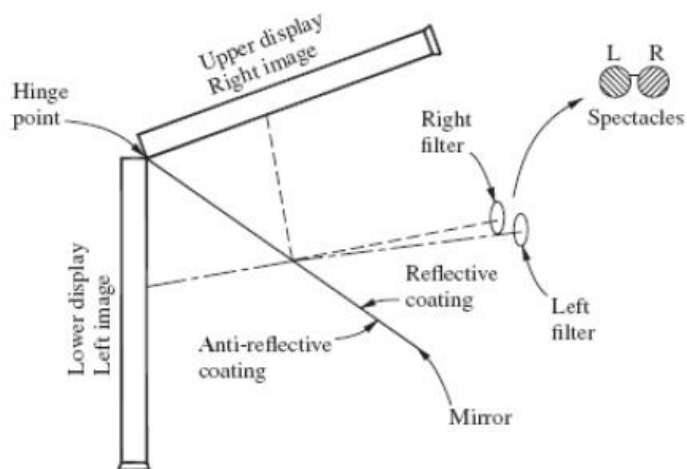

Figure 12-12. Stereoviewing principle of the polarizing filter screen display.

## 12-15. System Hardware

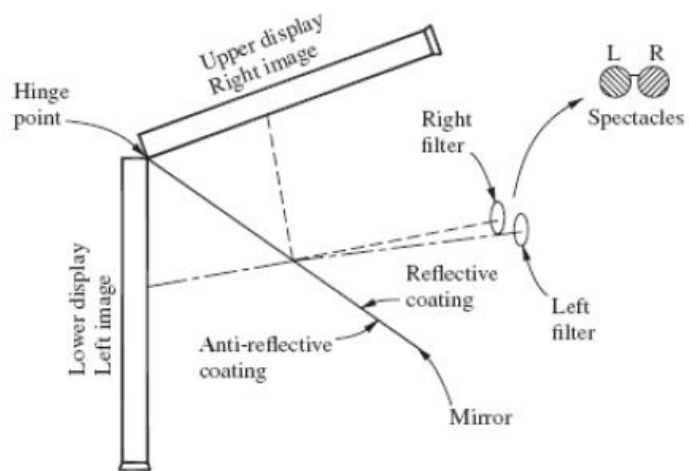

Figure 12-12. Stereoviewing principle of the polarizing filter screen display.

- ❖ The lower and upper displays (LCD monitors) are arranged so that the tops are nearly joined at the *hinge point* and the bottoms are spread out at an angle of approximately  $110^\circ$
- ❖ A partially reflective mirror bisects the angle of the displays with the reflective side facing the upper display and the anti-reflective side facing the lower display
- ❖ Understanding how the stereo image is formed requires knowledge of an interesting detail regarding LCD computer monitors



## 12-15. System Hardware

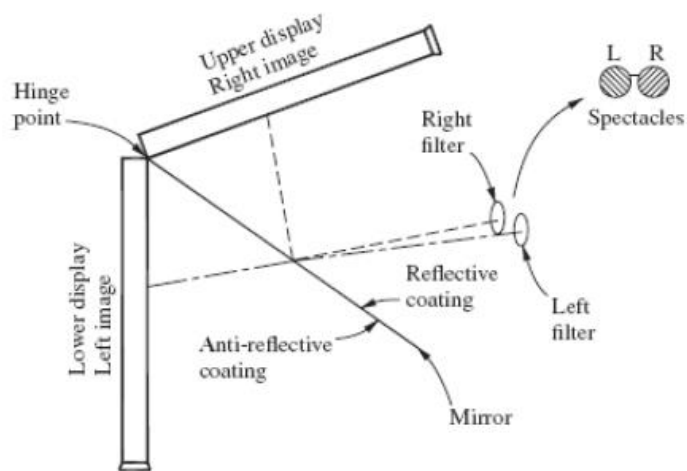

Figure 12-12. Stereoviewing principle of the polarizing filter screen display.

- ❖ The physical construction of an LCD requires the use of polarizing filters and as a result, light emanating from an LCD monitor is polarized, usually in a  $45^\circ$  orientation
- ❖ In the polarizing filter approach, light from the lower display passes through the anti-reflective side of the mirror without changing its polarization angle
- ❖ It will then pass through the filter (left filter in Fig. 12-12), that has the same polarization angle and will be visible to the left eye
- ❖ However, this polarized light will not pass through the filter that has the orthogonal orientation (right filter in Fig. 12-12)
- ❖ Light from the upper display changes polarization  $90^\circ$  by reflecting off the mirror and will therefore be blocked by the left filter but will pass through the right
- ❖ The result is that the left eye will see the left image (from the lower display) and the right eye will see the right image (from the upper display)

## 12-15. System Hardware



Figure 12-13. Softcopy photogrammetric workstation with polarizing filter stereo imaging. (Courtesy BAE Systems.)

- ❖ Figure 12-13 shows the polarizing filter display configured for a softcopy system
- ❖ One additional detail that is addressed in the design is the fact that the reflected image of the upper display will be reversed in a left/right sense
- ❖ An additional hardware device or software emulator is required to reverse the initial monitor image to that it appears normal in its mirrored state

## 12-15. System Hardware

- ❖ A second approach to stereoviewing uses a display monitor which shows alternating left and right images at 120 Hz, along with special viewing glasses that have liquid crystal shutters (LCS) which alternate at the same rate
- ❖ The LCS glasses receive signals transmitted by the computer—often from an infrared device—which control the alternating left and right masking functions
- ❖ At a particular instant, the left image is displayed on the monitor, and at the same time, the LCS mask over the right eye turns opaque while the LCS mask over the left eye is clear, as illustrated in Fig.12-14a ⇨ Since the right eye is blocked and the left eye is unobstructed, the operator sees the left image with the left eye

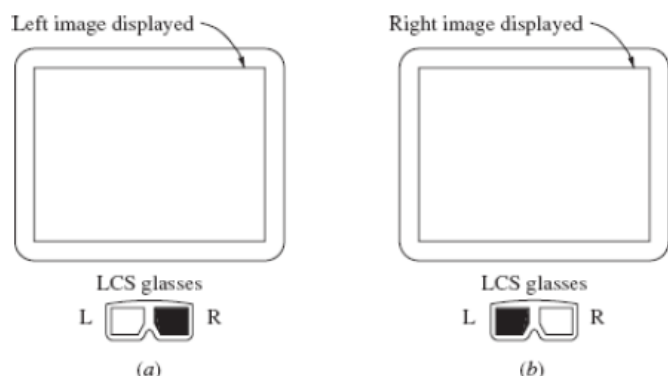

Figure 12-14. Stereoviewing principle of the alternating LCS shutter display. (a) view of the screen with the left image displayed and right LCS mask closed (b) view of the same screen a split second later, with the right image displayed and left LCS mask closed.



Figure 12-15. VR mapping workstation. (Courtesy Cardinal Systems.)

## 12-15. System Hardware

- ❖ A split second later, the right image is displayed on the monitor, and at the same time the LCS mask over the left eye turns opaque while the LCS mask over the right eye is clear, as illustrated in Fig. 12-14b
- ❖ This causes the operator to see the right image with the right eye
- ❖ When this is repeated at a rate of 120 Hz, the operator is unaware of the alternating images, yet the proper stereoview is created
- ❖ The system shown in Fig. 12-15, uses this method of stereo image display

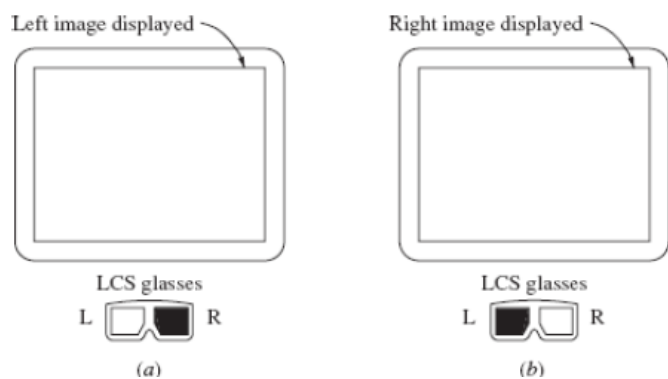

Figure 12-14. Stereoviewing principle of the alternating LCS shutter display. (a) view of the screen with the left image displayed and right LCS mask closed (b) view of the same screen a split second later, with the right image displayed and left LCS mask closed.



Figure 12-15. VR mapping workstation. (Courtesy Cardinal Systems.)

## 12-15. System Hardware

- ❖ An advantage of the polarizing screen method is that more than one person can view the stereo display at one time, with extra sets of inexpensive polarized spectacles
- ❖ The alternating-shutter approach shares the advantage of more than one person viewing the stereo display at a time, although this requires multiple sets of LCS glasses, which are more expensive than simple polarized spectacles
- ❖ The polarizing screen and alternating-shutter methods also allow the operator more freedom of movement compared to binocular viewing systems associated with analytical plotters

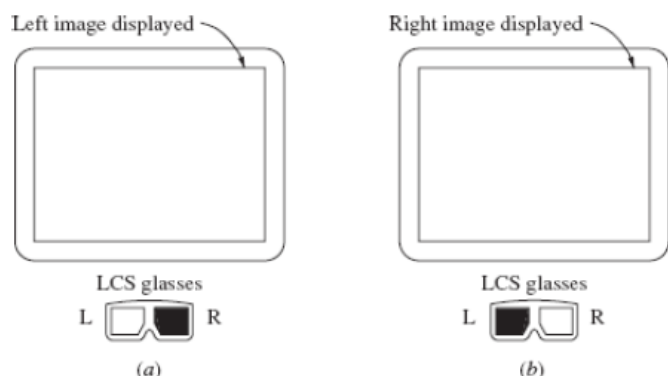

Figure 12-14. Stereoviewing principle of the alternating LCS shutter display. (a) view of the screen with the left image displayed and right LCS mask closed (b) view of the same screen a split second later, with the right image displayed and left LCS mask closed.



Figure 12-15. VR mapping workstation. (Courtesy Cardinal Systems.)

## 12-16. Image Measurements

- ❖ As is the case with all **stereoplotters**, manual image measurements are accomplished through operator control of a floating mark
- ❖ On a **softcopy stereoplotter**, a floating mark consists of left and right half marks which are superimposed on the left and right images, respectively
- ❖ An individual half mark consists of a single pixel, or small pattern of pixels in the shape of a dot, cross, or more complex shape
- ❖ The pixel(s) of the half mark is (are) set to brightness values and/or colors which give a high contrast with the background image
- ❖ When the operator moves the **X, Y**, or **Z** control, the positions of the individual half marks move with respect to the background images
- ❖ Once the floating mark visually coincides with a feature of interest, the operator can press a button or foot pedal to record the feature's position

## 12-16. Image Measurements

- ❖ Two approaches are used for half mark movement: a fixed mark with a moving image or a fixed image with a moving mark

- The first approach, which mimics the action of an analytical stereoplotter, keeps the individual half marks at the same physical position on the screen while the images pan across the screen under operator control
- This implementation places a high demand on the computer display in terms of data transfer rate, thus requiring a high-speed computer graphics adapter

- The second approach works by keeping the left and right images in a fixed position on the display while the individual half marks move in response to the operator's input
  - While this approach places far less demand on the display adapter, it creates additional problems
- ① When the half marks approach the edge of the image area, the images must be reloaded and redisplayed so that the half marks can be placed at the center of the viewing area
- ⇒ This discontinuous image shift can be quite disruptive to the operator, since it requires a corresponding shift in the direction of the operator's gaze

## 12-16. Image Measurements

- ❖ Two approaches are used for half mark movement: a fixed mark with a moving image or a fixed image with a moving mark

- The first approach, which mimics the action of an analytical stereoplotter, keeps the individual half marks at the same physical position on the screen while the images pan across the screen under operator control
- This implementation places a high demand on the computer display in terms of data transfer rate, thus requiring a high-speed computer graphics adapter

- The second approach works by keeping the left and right images in a fixed position on the display while the individual half marks move in response to the operator's input
  - While this approach places far less demand on the display adapter, it creates additional problems
- ① When the half marks approach the edge of the image area, the images must be reloaded and redisplayed so that the half marks can be placed at the center of the viewing area
- ⇒ This discontinuous image shift can be quite disruptive to the operator, since it requires a corresponding shift in the direction of the operator's gaze



## 12-16. Image Measurements

- ❖ Two approaches are used for half mark movement: a fixed mark with a moving image or a fixed image with a moving mark

- The first approach, which mimics the action of an analytical stereoplotter, keeps the individual half marks at the same physical position on the screen while the images pan across the screen under operator control
- This implementation places a high demand on the computer display in terms of data transfer rate, thus requiring a high-speed computer graphics adapter

- The second approach works by keeping the left and right images in a fixed position on the display while the individual half marks move in response to the operator's input
  - While this approach places far less demand on the display adapter, it creates additional problems
- ② Another problem, which is more subtle, is that the operator's eyes must follow the floating mark as it moves, which can cause eye strain
- ⇒ With the fixed half mark approach, the operator's gaze remains essentially fixed while the images move around it

## 12-16. Image Measurements

- ❖ A key **advantage** afforded by **softcopy plotters** is their ability to make point measurements automatically
  - ⇒ This is accomplished through some form of patternmatching technique, wherein a small subarray of digital numbers from the left image is matched with a corresponding subarray from the right image
- ❖ Finding the matching position is equivalent to manually setting the floating mark so that it appears to rest directly on a feature in the stereomodel
- ❖ Various methods are available for performing the pattern-matching operation

## 12-17. Orientation Procedures

- ❖ Softcopy plotters are oriented in a similar fashion to that of analytical plotters; i.e., the same three steps of interior, relative, and absolute orientation must be performed
- ❖ The key difference between orientations of softcopy and analytical plotters is that softcopy systems allow for greater automation in the process
- ❖ Interior orientation, which primarily consists of pointing on the fiducial marks, can be done directly under operator control, or by use of pattern-matching methods
- ❖ Systems that use pattern matching attempt to find the positions of the fiducial marks by matching a standard image of the fiducial, sometimes called a *template*, with a corresponding subarray from the image
- ❖ Once all fiducials have been located, a two-dimensional transformation can be computed to relate image coordinates (row and column) to the fiducial axis system

## 12-17. Orientation Procedures

- ❖ Relative orientation can also be greatly assisted by automatic pattern matching
- ❖ Small subarrays from the left image in the standard pass point locations are matched with corresponding subarrays from the right image
- ❖ Once a sufficient number of pass points have been matched (generally at least six points), a relative orientation can be computed
- ❖ Accuracy of the relative orientation can be improved by matching additional pass points, thus providing greater redundancy in the least squares solution

## 12-17. Orientation Procedures

- ❖ Absolute orientation is much less amenable to automation than interior or relative orientation
- ❖ In absolute orientation, three-dimensional measurements must be made on the positions of ground control points which appear in the model
- ❖ Since ground control points can have varying shapes and can appear anywhere within the model, they are more difficult to locate by automatic pattern-matching techniques  
⇒ In these cases, manual pointing on the control points is usually done.
- ❖ One situation where absolute orientation can be automated occurs when a block aerotriangulation has previously been performed on the digital images
- ❖ As a result of the aerotriangulation, exterior orientation parameters will have been determined for each photo
- ❖ Having known exterior orientation parameters essentially defines the absolute orientation, thus no additional measurements need to be taken

## 12-18. Epipolar Geometry

- ❖ Automatic methods can be used to set the floating mark on a feature
  - ⇒ This involves pattern matching, which can be a computationally intensive task
- ❖ To reduce the computational burden, it is helpful to constrain the search area so as to avoid unnecessary calculations
- ❖ By exploiting the principle of *epipolar geometry*, search regions can be constrained along a single line
- ❖ By using the principle of epipolar geometry, searching for matching points is much more efficient
- ❖ This is especially important when a large number of points must be matched, such as when a digital elevation model is created
- ❖ Many softcopy systems perform epipolar resampling after relative orientation so that the rows of pixels in both images lie along epipolar lines
  - ⇒ This resampling can increase the efficiency of pattern matching even further

## 12-18. Epipolar Geometry

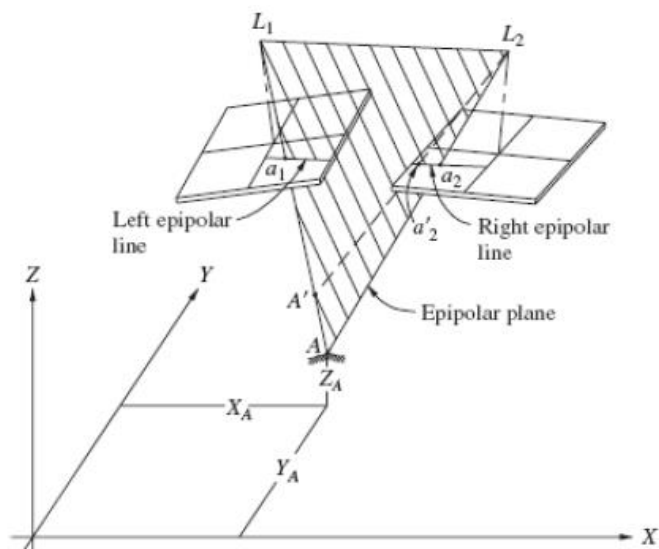

Figure 12-16. Epipolar geometry of a stereopair of photos.

- ❖ Coplanarity is the condition in which the left and right camera stations, an object point, and the left and right images of the object point lie in a common plane
- ❖ If relative orientation is known for a given stereopair, the coplanarity condition can be used to define epipolar lines
  - ⇒ This situation is illustrated in Fig. 12-16.
- ❖ The figure shows the intersection of the *epipolar plane* (any plane containing the two exposure stations and an object point, in this instance plane  $L_1AL_2$ ) with the left and right photo planes
- ❖ The 1 2 resulting lines of intersection are the *epipolar lines*
- ❖ They are important because, given the left photo location of image  $a_1$ , its corresponding point  $a_2$  on the right photo is known to lie along the right epipolar line

## 12-18. Epipolar Geometry

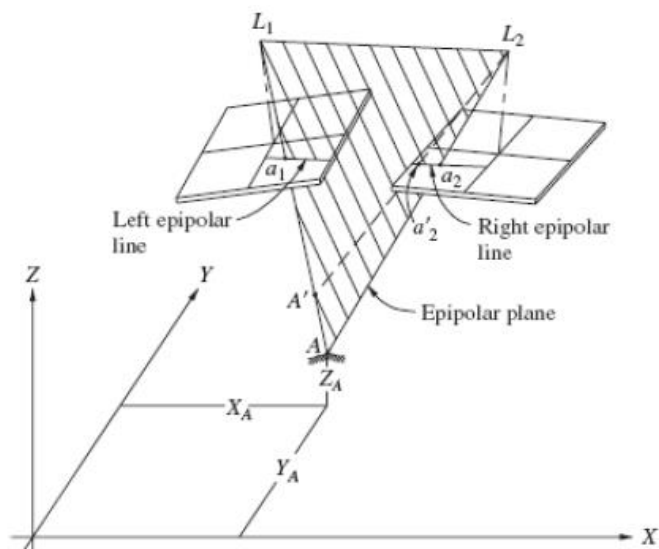

Figure 12-16. Epipolar geometry of a stereopair of photos.

- ❖ Based solely upon the location of image point  $a_1$ , object point  $A$  could be located anywhere along line  $L_1A$ , at an arbitrary  $Z$  elevation
- ❖ Based on an assumed object point position of  $A'$ , the corresponding location of its image on the right photo,  $a'_2$  can be calculated by the collinearity equations
- ❖ A small subarray of digital numbers at the location of point  $a'_2$  can be compared with a corresponding subarray at the location of point  $a_1$
- ❖ Since these two locations do not both correspond to images of object point  $A$ , the patterns would not match, and another point on the right epipolar line would be tried
- ❖ The search continues along the epipolar line until it zeros in on the corresponding image at  $a_2$ , where the patterns match
- ❖ The coordinates of image points  $a_1$  and  $a_2$  can then be used to determine the three-dimensional object space coordinates of point  $A$



## 12-18. Epipolar Geometry

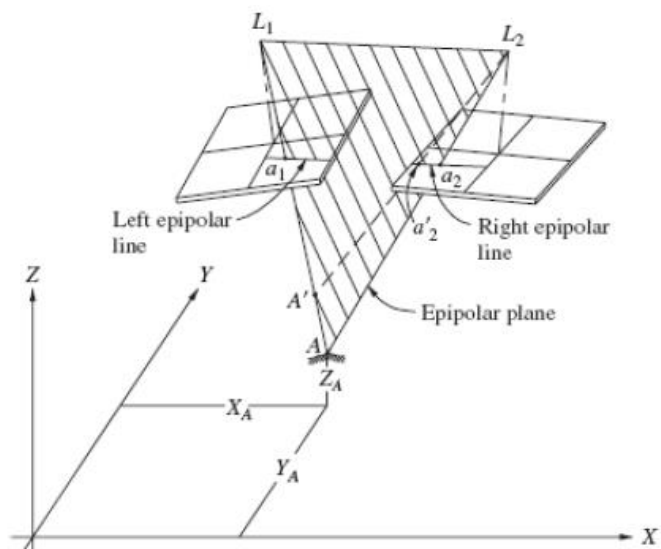

Figure 12-16. Epipolar geometry of a stereopair of photos.

- ❖ Based solely upon the location of image point  $a_1$ , object point  $A$  could be located anywhere along line  $L_1A$ , at an arbitrary  $Z$  elevation
  - ❖ Based on an assumed object point position of  $A'$ , the corresponding location of its image on the right photo,  $a'_2$  can be calculated by the collinearity equations
  - ❖ A small subarray of digital numbers at the location of point  $a'_2$  can be compared with a corresponding subarray at the location of point  $a_1$
- ❖ By using the principle of epipolar geometry, searching for matching points is much more efficient
    - ⇒ This is especially important when a large number of points must be matched, such as when a digital elevation model is created
  - ❖ Many softcopy systems perform epipolar resampling after relative orientation so that the rows of pixels in both images lie along epipolar lines
    - ⇒ This resampling can increase the efficiency of pattern matching even further