

# Hi-Fi / Stereo

JULY 1962 • 50 CENTS

## review

### GEORGE GERSHWIN

A PICTURE  
PORTFOLIO

THOUGHTS ON  
CONTEMPORARY  
MUSIC AND  
RECORDING

BY **IGOR  
STRAVINSKY**

THE BASICS  
OF **HI-FI**  
TROUBLESHOOTING

HOW TO  
SUCCEED IN  
COMPOSING  
WITHOUT  
REALLY  
SUCCEEDING

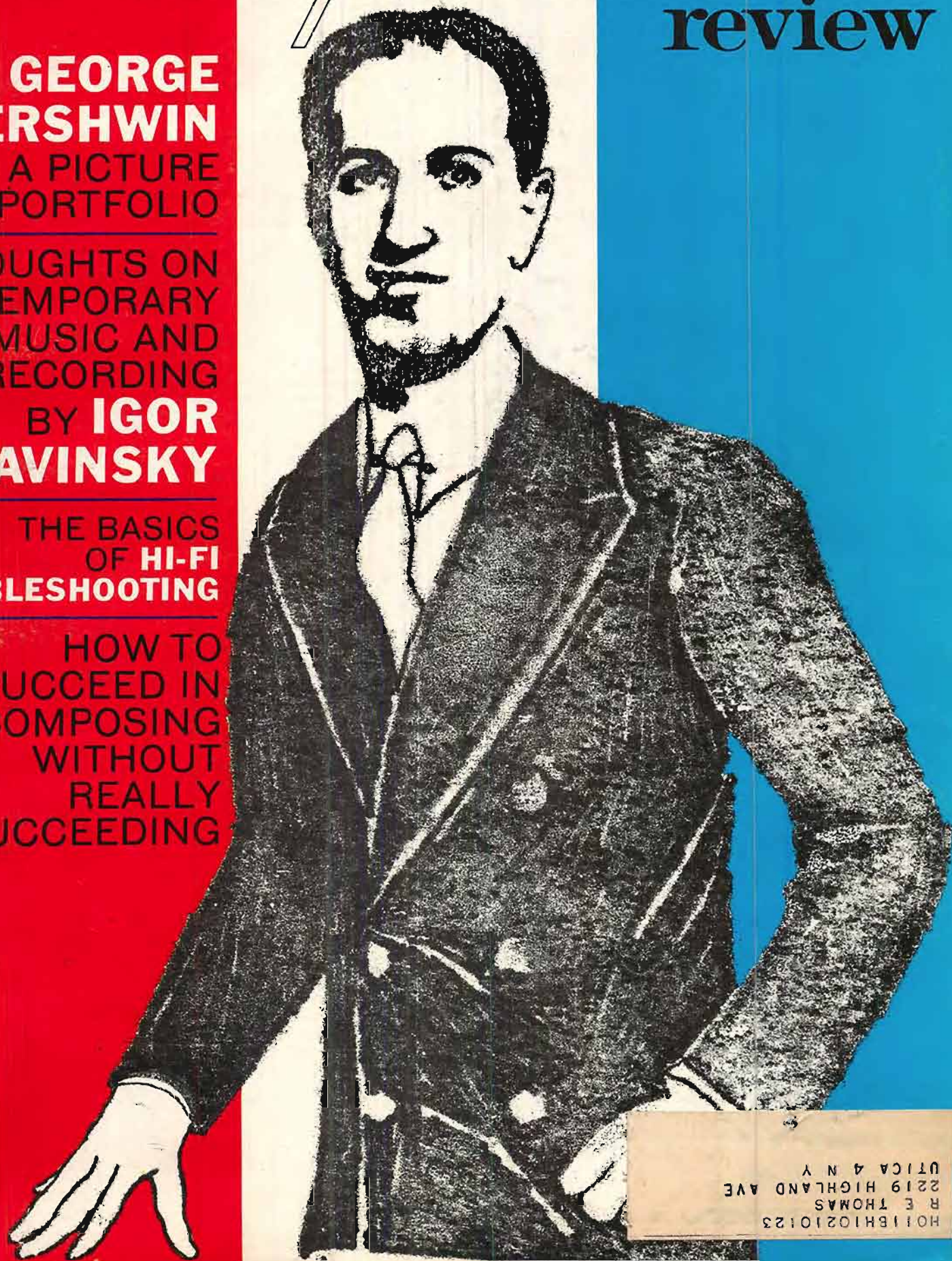

HOLLIBROOK 10123  
R E THOMAS  
2219 HIGHLAND AVE  
UTICA 4 N Y



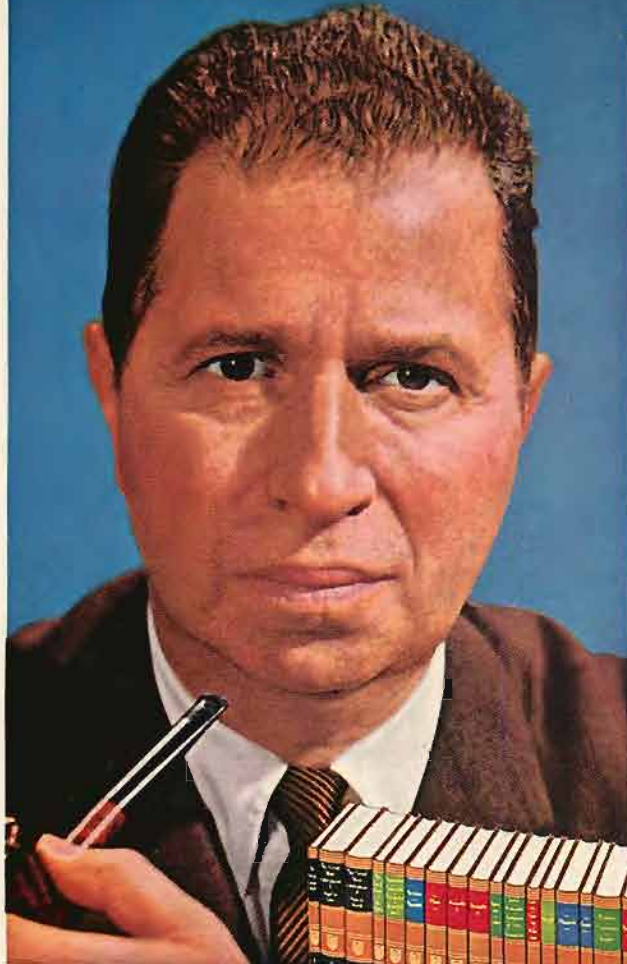

## A college education does not make an educated man

*Mortimer J. Adler*  
Dr. Mortimer J. Adler, Director of the Institute for Philosophical Research, Editor of the SYNTOPICON

"The ultimate end of education is not just to learn to be an engineer, a lawyer, a doctor, or a scientist. These are skills—like any others—which help you earn a living and render a useful service to society. But knowledge of any one particular subject is not necessarily evidence of an educated man.

"Education is the sum total of one's experience, and the purpose of higher education is to widen our experience beyond the circumscribed existence of our own daily lives. Most people have only begun their education when they finish school, and after school the steady pressure of a job narrows rather than expands their experience.

"That is why the Private Library Edition of the GREAT BOOKS described below was published—to give every thinking person, no matter what his degree of formal education, the opportunity to become a really educated man. Through this Private Library Edition of the GREAT BOOKS you can acquire for yourself the total experience of the whole human race. With that experience, you will then be far better equipped to face life and love it—to meet its challenges and problems with courage, confidence, and intelligence."



Published by the Encyclopaedia Britannica in collaboration with the University of Chicago

# GREAT BOOKS



Now available direct from the publisher with great new **SYNTOPICON**

VERY few people have either the time or money to return to school, and to embark on a program of self-education without a "teacher" is both unrewarding and unproductive.

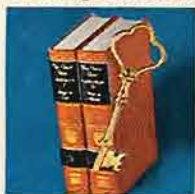

THE SYNTOPICON

Guidance, interpretation, discussion are necessary to help you relate the total experience of the whole human race to the problems of today. That is why this Private Library Edition of the GREAT BOOKS was published. The key to its enormous educational value is the "teacher" it provides—the amazing SYNTOPICON pictured here. The SYNTOPICON is a new concept in self-education. It is the product of 400,000 man-hours of research by 100 scholars over a period of eight years. It is quite literally a great "teacher" living in your home... always at your disposal to interpret the GREAT BOOKS to you.

As you begin to absorb and understand the great ideas by which man has

survived and progressed, you will begin to reflect their greatness in your own ability to think, speak, and act with a new and impressive maturity. You will have sounder judgment on political and economic issues as the great minds who conceived and contributed law and justice make the whole idea of government clear to you. You will develop a sounder philosophy of life as the accumulated experience of the race becomes your experience through the great minds of the ages.

You will not be limited in your business progress by your own narrow specialty, but will be prepared to handle the daily problems of top level management which call for broad general thinking rather than limited technical knowledge.

Even in your own personal life, the experience of mankind through century on century can guide you to the decisions and actions which have eternally resulted in the greatest success and contentment.

Don't miss this opportunity to learn all the details of this handsome Private Library Edition of the GREAT BOOKS.

Mail the attached card for a free descriptive booklet. It will explain how you can find new understanding of yourself and the world through the great ideas which have engrossed men since the written record of man began. It is in this way that one acquires an education. It is in this way that one acquires wisdom.

Mail the attached card now for **FREE BOOKLET**

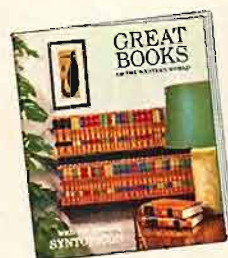

Simply tear out the attached card along perforated line, fill in and mail for your free, colorfully illustrated booklet describing the GREAT BOOKS and the SYNTOPICON. Or write to GREAT BOOKS OF THE WESTERN WORLD, Dept. 69-F, 425 N. Michigan Ave., Chicago 11, Ill



the incomparable new

# SHURE SERIES M33

*Stereo Dynetic®*

HIGH FIDELITY PHONOGRAPH CARTRIDGES

### NOT HOW MUCH? BUT HOW GOOD?

According to United Press' Preston McGraw, the Shure series M33 cartridges are "so good that a hard-shelled listener might suspect Shure engineers of not knowing what they had when they hung a price tag on them."

We knew, all right, Mr. McGraw. It's just that we don't believe the best sounding cartridge need be the most expensive. The new Series M33, after all, was developed by the same team of engineers who developed the redoubtable Shure M3D series . . . the world's first truly high fidelity stereo cartridge. Numerically, Shure has made more highest-quality stereo cartridges than any other manufacturer—and they're used by more critics and independent hi-fi authorities than any other. Chronologically, Shure had a two year head start on the others. In short, Shure has learned how to make these critical components in the kind of quantities that result in lower prices.

### THE SOUND OF SPECIFICATIONS

Again quoting Mr. McGraw: "Professional engineers are largely impressed by specifications, and the specifications of the M33 (except for compliance) are not unprecedented. But the way it sounds is something else again. The M33 puts flesh and bones on specifications. It brings out sound from records that more expensive cartridges do not."

He's right. To begin with, Shure specifications (as published) are not theoretical laboratory figures, or mere claims . . . they are actual production standards. 20 to 20,000 cps. response may appear average. But what the bare specifications don't show is that the M33 series goes right through the audible spectrum without a hint of the break-up prevalent in most other cartridges. Also, it is remarkably free from disconcerting peaking at this frequency or that. Result: absolutely smooth, transparent, *natural* sound re-creation. (Incidentally, where would you find a record that goes from 20 to 20,000 cps. with genuine music on it?)

Separation is over 22.5 db. at 1000 cps. Much more than necessary, really. Again, the separation figure doesn't show that the M33's separation is excellent throughout the audible spectrum. No cross-talk between channels. Even when an oboe plays.

And the matter of compliance:  $22 \times 10^{-6}$  cm. per dyne for the M33-5. Now there's a specification! According to Mr. McGraw, the Shure stylus feels like a "loose tooth." And so it should. The incredible compliance of the M33-5 gives it the ability to respond instantly to the manifold and hyper-complex undulations of the record groove. Superior sound is one outcome of the superb compliance.

Another is the ability to track the record at low force. *The M33-5 will track at forces as low as any other cartridge on the market today.*

SPECIFICATIONS	M33-5	M33-7
----------------	-------	-------

Channel Separation (at 1000 cps)	Over 22.5 db	Over 22.5 db
Frequency Response	20 to 20,000 cps	20 to 20,000 cps
Output Voltage (per channel, at 1000 cps)	6 mv	6 mv
Recommended Load Impedance (per channel)	47,000 ohms	47,000 ohms
Compliance; Vertical & Lateral	$22.0 \times 10^{-6}$ cent. per dyne	$20.0 \times 10^{-6}$ cent. per dyne
Tracking Force	$\frac{1}{2}$ to 1.5 grams	1.5 to 3 grams
Inductance	600 millihenrys	600 millihenrys
D.C. Resistance	750 ohms	750 ohms
Stylus:	.0005" diamond	.0007" diamond
Terminals	4 terminal. (Furnished with adapters for 3-terminal stereo or monaural use.)	
Mounting Centers		Fits Standard $\frac{1}{2}$ "

One other item: if your tracking force is 4 to 6 grams, the even lower cost M77 Stereo Dynetic will deliver the best sound you can possibly get from your cartridge-arm combination.

### THE ULTIMATE TEST

Give a listen. In fact, compare the Shure M33 series with any other cartridge, regardless of price, in A-B tests (we do it all the time). If you are not impressed with the distinct difference and greater naturalness of the Shure, don't buy it. That's punishment enough for us.

### PRICES:

Why spend more than you must? M33-5 and M33-7 net for \$36.50 The M77 is only \$27.50

If you *insist* on Shure when you buy, you can *demand* more from the rest of your system when you play . . . write for literature, or still better, hear them at your high fidelity showroom: Shure Brothers, Inc., 222 Hartrey Avenue, Evanston, Illinois.

"Brings out sound from records that more expensive cartridges do not"

Preston McGraw  
United Press  
International Hi-Fi  
equipment reviewer





THE AT6 AUTOMATIC TURNTABLE DOES NOT COME TO YOU AS SHOWN... IN THE FORM OF ITS SEPARATE PARTS... BUT THE TONEARM IS PRE-MOUNTED, FULLY INTEGRATED AT THE FACTORY TO INSURE CORRECT PERFORMANCE



## Garrard's New AT6 Automatic Turntable How good can it be for only \$54.50?

*THE ANSWER: So good it will excite you!*

You may be wondering, for example, whether the AT6's dynamically balanced tonearm will not only accept and track "professional" cartridges, but also bring out the best in them. Definitely yes! This is a counterweight balanced arm — the pressure being set in two steps. First — you move the counterweight until the arm floats at zero pressure. Then you merely move the indicator to the correct pressure shown on the built-in gauge, set on the side of the arm for easy reading. Once balanced, the AT6 arm will track each side of the stereo groove precisely and perfectly at the lowest pressure specified by the cartridge manufacturer. □ Those who know tonearms will appreciate that this type of arm was once available only as a separate component. Now it is not only yours in the AT6 but integrated — scientifically mounted

to insure precision performance. But that isn't all... □ The turntable of the AT6 is oversized, heavy, balanced. Here, too, are the features you would expect to find in separately sold turntable units — high torque, no noise, no rumble. The motor was designed specifically to match the AT6 turntable, and built by the Garrard Laboratories to deliver perfect, constant speed, silently. It is double-shielded against magnetic hum—an important feature.



□ Add to this such AT6 advantages as: —(1) the convenience of automatic play, when desired (automatic and single play spindles furnished), plus the luxury of being able to intermix any size, any sequence of records. (2) Design so compact that the AT6 will fit easily into any record player cabinet. □ Yes, if you have been wondering just how much you can expect from the AT6 Automatic Turntable at its price of \$54.50, just consider these features. Better still, try one. You will be startled, and gratified, by this superb, completely up-to-date record-playing component made possible only by the unexcelled facilities and unique experience of the Garrard Laboratories.

For literature, write Dept. GG-122,  
Garrard Sales Corporation  
Port Washington, New York

**GARRARD'S** **AT6**

**AUTOMATIC TURNTABLE**

Canadian inquiries to Chas. W. Pointon, Ltd., 66 Racine Road, Rexdale, Ontario — Territories other than U.S.A. and Canada to Garrard Engineering & Mfg. Co., Ltd., Swindon, Wilts., England  
CIRCLE NO. 10 ON READER SERVICE CARD



# HiFi / Stereo review

## THE MUSIC

- 22** THE BASIC REPERTOIRE  
*Ravel's Daphnis and Chloë* . . . . . MARTIN BOOKSPAN
- 29** THOUGHTS ON CONTEMPORARY  
MUSIC AND RECORDING  
*A modern master speaks from experience* . . . . . IGOR STRAVINSKY
- 35** NEW IDEAS ABOUT EARS  
*Hearing isn't as simple as it sounds* . . . . . J. GORDON HOLT
- 44** GEORGE GERSHWIN: A PICTURE PORTFOLIO  
*A tribute to our best-known composer* . . . . . EDWARD JABLONSKI
- 50** HOW TO SUCCEED IN COMPOSING  
WITHOUT REALLY SUCCEEDING  
*The fiscal facts of musical creation* . . . . . WILLIAM FLANAGAN
- 76** A BIRTHDAY PRESENT FOR STRAVINSKY  
*Columbia's five-disc festival* . . . . . DAVID HALL
- 79** THE ART OF RUTH DRAPER  
*A theatrical legend lives again on records* . . . . . ROBERT SHELTON

## THE EQUIPMENT

- 18** BEGINNERS ONLY  
*A basic approach to audio* . . . . . HANS FANTEL
- 25** TECHNICAL TALK  
*Comment on current hi-fi developments* . . . . . JULIAN D. HIRSCH
- 34** INSTALLATION OF THE MONTH  
*Sound out of sight*
- 39** BASIC HI-FI TROUBLESHOOTING  
*What to do before calling the serviceman* . . . . . ALEXANDER ROSNER

## THE REVIEWS

- 61** HIFI/STEREO CLASSICS
- 81** HIFI/STEREO JAZZ
- 86** HIFI/STEREO REEL AND CARTRIDGE
- 91** HIFI/STEREO ENTERTAINMENT

## THE REGULARS

- 6** EDITORIALY SPEAKING
- 10** HIFI SOUNDINGS
- 14** LETTERS
- 16** JUST LOOKING
- 54** SOUND AND THE QUERY
- 55** BEST OF THE MONTH
- 73** MUSIQUIZ  
COVER DESIGN BY ROBERT TUCKER

Copyright © 1962 by Ziff-Davis Publishing Company. All rights reserved. HIFI/STEREO REVIEW July, 1962, Volume 9, Number 1, is published monthly by Ziff-Davis Publishing Company at 434 South Wabash Avenue, Chicago 6, Illinois. Subscription rates: one year United States and possessions \$5.00; Canada and Pan-American Union Countries \$5.50; all other foreign countries \$6.00. Second-class postage paid at Chicago, Illinois and at additional mailing offices. Authorized as second class mail by the Post Office Department, Ottawa, Canada, and for payment of postage in cash.

(For information on facing advertisement circle no. 10 on reader service card.)



# HiFi/Stereo review

**PUBLISHER**  
PHILLIP T. HEFFERNAN

**EDITOR**  
FURMAN HEBB

**MUSIC EDITOR**  
DAVID HALL

**MANAGING EDITOR**  
ROBERT CAMPBELL

**ART EDITOR**  
ROBERT TUCKER

**ASSOCIATE EDITORS**  
HANS H. FANTEL  
JAMES HINTON, JR.

**ASSISTANT EDITORS**  
JILL BENGELSDORF  
BARBARA GLUCK

**CONTRIBUTING EDITORS**  
CHRISTIE BARTER  
MARTIN BOOKSPAN  
WILLIAM FLANAGAN  
STANLEY GREEN  
NAT HENTOFF  
JULIAN D. HIRSCH  
GEORGE JELLINEK  
IGOR KIPNIS

**EDITORIAL CONSULTANT**  
OLIVER READ

**ADVERTISING  
SALES MANAGER**  
LAWRENCE SPORN

**ADVERTISING  
SERVICE MANAGER**  
ARDYS C. MORAN

## ZIFF-DAVIS PUBLISHING COMPANY

Editorial and Executive Offices (Oltegon 9-7200)  
One Park Avenue, New York 16, New York  
William B. Ziff, Chairman of the Board (1946-1953)  
William Ziff, President  
W. Bradford Briggs, Executive Vice President  
Hershel B. Sarbin,  
Vice President and General Manager  
M. T. Birmingham, Jr.,  
Vice President and Treasurer  
Robert P. Inceasing, Circulation Director  
Charles Housman, Financial Vice President  
Stanley R. Greenfield, Vice President  
Midwestern and Circulation Office (Wabash 2-4911)  
434 South Wabash Avenue, Chicago 5, Illinois  
Midwestern Advertising Manager: Jack Tierney  
Western Office (Chestview 4-0265)  
9025 Wilshire Boulevard, Beverly Hills, California  
Western Advertising Manager: Bud Dean  
Southern Representative  
William G. Browning  
804 First National Bank Building  
Temple, Texas  
Prospect 8-3311  
Foreign Advertising Representative  
D. A. Goodall Ltd., London, England

**SUBSCRIPTION SERVICE:** All subscription correspondence should be addressed to HiFi/Stereo Review, Circulation Department, 434 South Wabash Avenue, Chicago 5, Illinois. Please allow at least six weeks for change of address. Include your old address, as well as new—enclosing if possible an address label from a recent issue.

**EDITORIAL CONTRIBUTIONS** must be accompanied by return postage and will be handled with reasonable care; however, publisher assumes no responsibility for return or safety of art work, photographs, or manuscripts.



## EDITORIALLY SPEAKING

by FURMAN HEBB

**T**WO PIECES of Federal legislation seem to promise that the long-delayed blossoming forth of educational television is at last nearly at hand. The Government has allocated some money for the purpose, and it seems that television set manufacturers will soon be required to make all-channel receivers. This latter will make it feasible for educational stations to broadcast on the uncrowded UHF band, which until now has been limited in its growth because few listeners have had sets to receive UHF stations. The establishment of educational television on a firm footing will undoubtedly stimulate new interest in all the arts. Music, of course, will receive its fair share of coverage and, in fact, will have a golden opportunity to win new supporters.

What bothers me about this is how well this opportunity will be utilized. I say this because in my experience programs of serious music on television often do a genuine disservice to the music. When I see Eugene Ormandy and his Philadelphians on television, as I did some weeks ago, I expect more than just to see a concert. I also want to hear it. The telecast in question had such poor sound quality that I turned it off long before it was over, preferring to listen to recordings. Of course, there is no denying that it is interesting to watch a great conductor at work, but I would rather listen to good sound sans images than to see images sans good sound.

Of the last ten or fifteen serious musical programs I have seen on television, I recall only two presentations that had acceptable sound. These were both NBC Opera productions—English-language versions of *Don Giovanni* and *The Love of Three Kings*—which were to my mind perfect examples of how music should be presented on television. But the great majority of the programs I have seen have been far, far below high-fidelity standards.

The real tragedy of this situation is that in many instances televised musical programs—which set out with the praiseworthy aim of bringing great music to the masses—probably backfire because of poor audio quality and serve only to confirm many viewers' opinions that classical music really is pretty boring. It is bad enough that most television sets cannot reproduce music adequately. But to compound the hurt by transmitting a substandard audio channel is inexcusable.

\*\*\*\*\*

Coming Next Month in HiFi/STEREO REVIEW

**PHONIES AMONG THE SYMPHONIES**

by Jan LaRue

**UNDERSTANDING THE DECIBEL**

by Herman Burstein

**LORD AYLESFORD IN DARKEST AFRICA**

by Janos Starker

\*\*\*\*\*



COLUMBIA RECORD CLUB  
now offers new members

# The Best of Two Musical Worlds

AS A NEW MEMBER YOU ARE INVITED TO TAKE

**ANY 6** of these \$3.98 to \$5.98 records **\$1.89** REGULAR or STEREO FOR ONLY RETAIL VALUE UP TO \$35.88

if you join the Club now and agree to purchase as few as 6 selections from the more than 400 to be made available during the coming 12 months

### GREAT JAZZ

<b>ANDRE PREVIN</b> A Touch of Elegance THE MUSIC OF DUKE ELLINGTON COLUMBIA 50	<b>ANDRE PREVIN AND HIS TRIO</b> Give My Regards To Broadway COLUMBIA 51	<b>TIME OUT</b> THE DAVE BRUBECK QUARTET COLUMBIA 52	<b>Time Further Out</b> The Dave Brubeck Quartet COLUMBIA 53
<b>MILES DAVIS</b> Sketches of Spain COLUMBIA 56	<b>THE DUKES OF DIXIELAND</b> BREAKIN' IT UP ON BROADWAY COLUMBIA 81	<b>THE MODERN JAZZ QUARTET</b> Patterns COLUMBIA 95	<b>AHMAD JAMAL</b> HAPPY MOODS ARGO 96
<b>Quincy Jones</b> and his Orchestra at NEWPORT '61 Mercury 131	<b>GERRY MULLIGAN QUARTET</b> what is there to say? COLUMBIA 133	<b>WHO'S WHO IN THE SWINGING SIXTIES</b> THE MANY SOUNDS OF JAZZ TODAY ★ LOUIS BRUBECK ★ MILES DAVIS ★ LIONEL HAMPTON ★ DUKE ELLINGTON and many more COLUMBIA 229	<b>MIDNIGHT IN MOSCOW</b> Kenny Ball KAPPA 232
<b>MILES DAVIS</b> KIND OF BLUE COLUMBIA 290	<b>LAMBERT, HENORICKS &amp; ROSS!</b> COLUMBIA 291	<b>ELLINGTON INDIGOS</b> COLUMBIA 292	<b>CHARLES MINGUS</b> and his Jazz Group MINGUS DYNASTY Must Indigo - night more COLUMBIA 293
<b>CANNONBALL ADDERLEY QUINTET</b> in CHICAGO Mercury 294	<b>BILLIE HOLIDAY</b> The Golden Years COLUMBIA 285-286-287 (Counts as Three Selections) (Monaural only)		

### GREAT CLASSICAL

<b>HANDEL: MESSIAH</b> LEONARD BERNSTEIN N. Y. PHILHARMONIC COLUMBIA 171-172 (Counts as Two Selections)	<b>CLAIR de LUNE</b> A Debussy Piano Recital by PHILIPPE ENTREMONT COLUMBIA 174	<b>Rhapsody in Blue</b> An American in Paris Leonard Bernstein plays Geschwin COLUMBIA 176	
<b>FINLANDIA</b> PHILADELPHIA ORCHESTRA - MORANON YASERHARU CHOIR plus - Valde Triste - Swedish Rhapsody - Peer Gynt Suite No. 1 COLUMBIA 177	<b>BETHOVEN</b> Piano Concerto No. 5 "Emperor" LEON BLSHER SZELL CLEVELAND ORCH. COLUMBIA 183	<b>BETHOVEN</b> Violin Concerto ISAAC STERN COLUMBIA 184	<b>Bach Organ Favorites</b> E. Power Biggs COLUMBIA 186
<b>CHOPIN:</b> The 14 Waltzes Braldovsky COLUMBIA 187	<b>RAVEL:</b> Bolero - La Valse Rapsodie Espagnole LEONARD BERNSTEIN N. Y. PHILHARMONIC COLUMBIA 191	<b>STRAVINSKY</b> conducts The "FIREBIRD" COMPLETE BALLET COLUMBIA 193	<b>SHOSTAKOVICH SYMPHONY No. 5</b> LEONARD BERNSTEIN NEW YORK PHILHARMONIC COLUMBIA 195
<b>FLAMENCO PURO</b> SABICAS COLUMBIA 198	<b>Music of EDGAR VARÈSE</b> Robert Craft compiling Woodwinds, Brass and Percussion COLUMBIA 201	<b>VIVALDI</b> FOUR CONCERTOS LEONARD BERNSTEIN conducting the NEW YORK PHILHARMONIC with soloists COLUMBIA 220	<b>ORFF: GARMINA BURANA</b> THE PHILADELPHIA ORCHESTRA soloists and chorus DAN LINDY conducting COLUMBIA 342
<b>Mozart Concertos</b> Nos. 22 and 23 ROBERT CASADESUS GEORGE SZELL Columbia Symphony Orchestra COLUMBIA 206	<b>MAHLER</b> Symphony No. 4 BERNSTEIN New York Philharmonic COLUMBIA 218	<b>SVIATOSLAV RICHTER</b> at CARNEGIE HALL 5 Beethoven Sonatas COLUMBIA 202-203 (Counts as Two Selections) (Monaural only)	

YES... HERE'S A WONDERFUL OPPORTUNITY to choose from classical masterworks performed by world-renowned artists - and jazz gems played by world-famous stars! By joining now, you may have ANY SIX of the 40 outstanding records shown on this page - up to a \$35.88 retail value - for only \$1.89. What's more, you'll also receive a remarkable hi-fi/stereo test record - absolutely FREE!

TO RECEIVE YOUR 6 RECORDS FOR ONLY \$1.89 - simply fill in and mail the coupon. Be sure to indicate whether you want your six records (and all future selections) in regular high-fidelity or stereo. Also indicate which Club Division best suits your musical taste: Classical; Listening and Dancing; Broadway, Movies, Television and Musical Comedies; Jazz.

HOW THE CLUB OPERATES: Each month the Club's staff of music experts selects outstanding records from every field of music. These selections are fully described in the Club's entertaining and informative music Magazine, which you receive free each month.

You may accept the monthly selection for your Division... or take any of the wide variety of other records offered in the Magazine, from all Divisions... or take no record in any particular month. Your only membership obligation is to purchase six records from the more than 400 to

be offered in the coming 12 months. Thereafter, you have no further obligation to buy any additional records... and you may discontinue membership at any time.

FREE BONUS RECORDS GIVEN REGULARLY. If you wish to continue as a member after purchasing six records, you will receive - FREE - a bonus record of your choice for every two additional selections you buy.

The records you want are mailed and billed to you at the list price of \$3.98 (Classical \$4.98; occasional Original Cast recordings somewhat higher), plus a small mailing and handling charge. Stereo records are \$1.00 more.

MAIL THE COUPON TODAY to receive your 6 records - plus a free hi-fi/stereo test record - for only \$1.89.

NOTE: Stereo records must be played only on a stereo record player.

**FREE** If you join now  
**TEST RECORD**  
FOR HI-FI AND STEREO MACHINES

This remarkable 7" record permits you to check the performance of your phonograph regardless of the type you own.



COLUMBIA RECORD CLUB, Dept. 220-5  
Terre Haute, Indiana

I accept your special offer and have written in the boxes below the numbers of the six records I wish to receive for \$1.89, plus small mailing and handling charge. I will also receive a hi-fi stereo test record - FREE.

Enroll me in the Club Division indicated below, with the understanding that I may select records from any Division. I agree to purchase six selections from the more than 400 to be offered during the coming 12 months, at the list price plus small mailing and handling charge. Thereafter, if I decide to continue my membership, I am to receive a 12" bonus record of my choice FREE for every two additional selections I accept.

Name.....  
(Please Print)

Address.....

City..... ZONE..... State.....

BE SURE TO COMPLETE ALL 3 ITEMS BELOW

1 SEND ME THESE SIX RECORDS  
(fill in numbers below)

--	--	--	--	--	--

2 SEND MY SIX RECORDS AND ALL FUTURE SELECTIONS IN (check one box)

REGULAR HIGH-FIDELITY  STEREO

3 ENROLL ME IN THE FOLLOWING DIVISION (check one box)

Classical  Listening & Dancing  Jazz  
 Broadway, Movies, Television & Musical Comedies

APO, FPO addresses: write for special offer  
CANADA: prices slightly higher; 1111 Leslie St., Don Mills Ont.  
232 **54-KE (REG)** **54-SE (STER)**

© "Columbia," ® "Epic," © Marcap Reg. © Columbia Records Distribution Corp., 1962



# NEW FROM SCOTT

## FINEST FM MULTIPLEX TUNER IN THE WORLD

### WITH AMAZING ELECTRONIC BRAIN

### THAT ACTUALLY THINKS FOR YOU!

This Wide-Band FM multiplex tuner is designed for the most critical stereo listener and for the most exacting applications imaginable. Its many features and stringent standards of performance make it the prudent choice for broadcast station monitoring. The famed advanced engineering group at H.H. Scott believes the sophisticated circuitry of the 4310 to represent the highest possible achievement in tuner engineering at this state of the art. This circuitry results in IHFM sensitivity of 1.9 microvolts. Scott's revolutionary Time-Switching multiplex section gives you practically noise-free reception of even weakest stereo signals, with separation of 30 db or better . . . truly an outstanding design achievement.

This superb tuner incorporates an amazing new "electronic brain" which is invaluable for serious tape recordists and discriminating listeners. As you tune across the FM dial, the 4310 AUTOMATICALLY switches to multiplex when a stereo broadcast is reached. If serious interference occurs, however, the tuner will switch back instantly and automatically to the monophonic FM mode, which is less susceptible to background noise. You completely disable this feature if you so desire, or you can set it so that switching occurs at that level of interference which you consider objectionable. Using this automatic feature, you hear practically flawless reception, with the tuner instantly picking the optimum mode for existing signal conditions.

This feature is essential for the tape recordist who wishes his recordings of prized material to be undisturbed by sudden interference, as often happens on very weak signals. The exceptional design and advanced features of the new H. H. Scott 4310 have already established new standards of achievement in the FM Field.

**IMPORTANT TECHNICAL INFORMATION:** IHFM sensitivity 1.9  $\mu$ v; Capture ratio 2.2 db; Signal to noise ratio 60 db; Harmonic distortion 0.5%; Frequency response 30-15,000 cps  $\pm$  1db; Selectivity 50 db; 4 FM IF stages; Cascade RF stage; Size in accessory case 15½ W x 5¼ H x 13¼ D. Rack mounted model available for broadcast station use.

Write today for technical details on these new tuners:



H. H. Scott, Inc., 111 Powdermill Rd., Maynard, Mass. Dept. 65



**Separate VU meter for each channel.** You can actually measure stereo separation between channels with these accurate meters enabling you to tune and orient your antenna for maximum stereo separation. Separate controls allow adjustment for broadcasts having unequal channel levels. Precision step-type master attenuator.

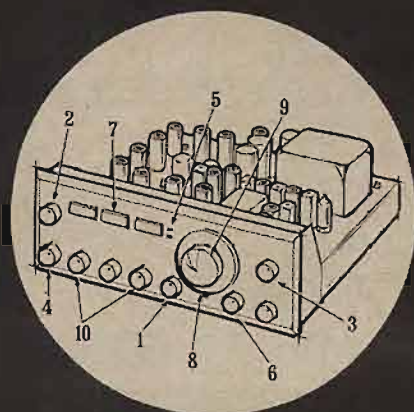

**Professional front panel controls:** 1. Stereo Threshold. 2. Multiple Diversity. 3. Precision Step-Type Level. 4. Stereo Selector. 5. Automatic Stereo Indicator. 6. Interstation Noise Suppressor. 7. Precision Signal Strength and Tuning Meter. 8. Logging Scale. 9. Main Tuning Dial. 10. Separate Level Controls for each channel.

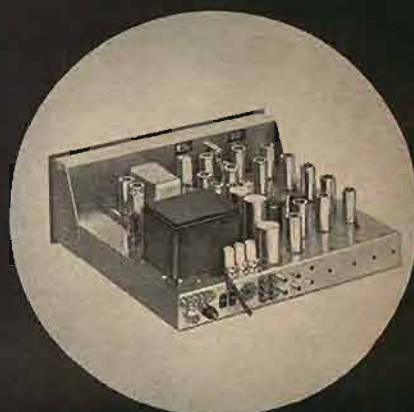

**Unique circuit features:** Diversity facilities for monitor and rebroadcast installations; Special tape recording filters; Automatic Stereo Threshold; Heavily silver-plated cascade front end; Provision for 72 ohm or 300 ohm balanced or unbalanced antenna inputs; 600 ohm output available. Automatic switching from monophonic to multiplex.





4310 Wide-Band FM Multiplex Broadcast Monitor Tuner



**New 350 FM Multiplex Tuner**  
— Incorporates the latest advances in multiplex circuitry. Sensitivity  $2.5 \mu\text{v}$ . 3 FM IF stages. Precision tuning meter. Silver-plated front end. Sharp filtering circuits permit flawless stereo tape recording. Stereo separation can match exacting FCC transmission specifications. \$199.95, East of Rockies.

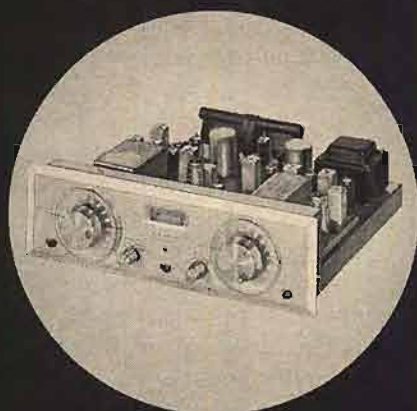

**New 333 AM/FM Multiplex Tuner**  
— Combines the features and performance of the 350 FM Multiplex tuner with a famous Scott Wide-Range AM tuner all on one compact chassis. You can receive Monophonic AM or FM, AM/FM stereo or new FM Multiplex Stereo, FM sensitivity  $2.2 \mu\text{v}$ . Two AM bandwidth positions. Loopstick antenna for AM.

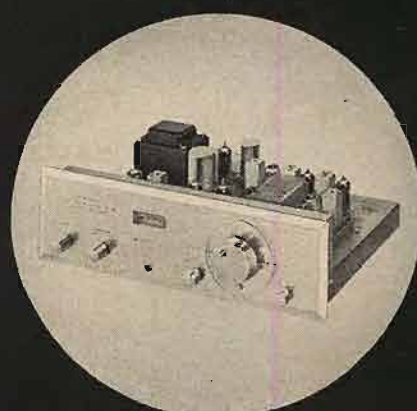

**LT-110 Wide-Band FM Multiplex Tuner Kit**  
— Build your own fabulous Scott Tuner. The LT-110 includes the same superb multiplex circuitry as the 350. Pre-wired multiplex section and front end. Full color instruction book. You can build the LT-110 in less than 12 hours. Sensitivity  $2.2 \mu\text{v}$ . \$159.95, East of Rockies.



portable  
perfection  
for  
hi-fi fans



From Denmark comes this aristocrat of portables. Superb AM-FM-Shortwave performance with all the features you've ever wanted in a portable: 12 transistor power with push-pull output and a 5" x 7" speaker, flywheel tuning, full range independent tone controls, pushbutton selection, loudspeaker-earphone output and separate tuner output, plus plug-in connection for an auto antenna for over-the-road hi-fi.

Complete information is available on request. Write for the name of your nearest dealer.



By appointment  
to the Royal Danish Court

**DYNACO**

DYNACO, INC.  
3912 Powelton Ave., Phila. 4, Pa.

CIRCLE NO. 15 ON READER SERVICE CARD

## HiFi Soundings



by DAVID HALL

### THE INTERNATIONAL LOOK

A FEW MONTHS ago I had the pleasure of a visit to Rome to attend the inauguration of the huge new RCA Italiana recording studios. RCA's Rome plant is unusually interesting from the technological viewpoint, for it offers complete facilities for the making of records from studio session to final manufacture and packing. Even more interesting, however, is the way in which the new plant symbolizes today's increasingly broad international outlook on the part of the large record companies.

Of course, international arrangements in the record business are nothing new. Back in the 1930's the major world-wide record combine was Electric & Musical Industries, Ltd. of England (makers of His Master's Voice, Columbia, and Parlophone records in England), and serious disc collectors gained a surprising amount of knowledge about music-making in other countries thanks to the recorded performances made available from EMI through both RCA Victor and Columbia. For example, it was through the medium of recording, rather than through concert performances, that the conducting artistry of the late Sir Thomas Beecham became known to large numbers of music lovers in this country.

Today, not one but several international disc combines are fighting it out for a share of the American record buyer's dollar. Whereas in the past an overseas record firm would be content to make an exchange agreement with an American counterpart, today's giant international competitors are far more aggressive. In the old days EMI issued its recordings through RCA Victor and Columbia with no special identification. Then, in 1953, it established its own sales organization and special label for America—Angel, thus following the pattern set after the war by its biggest competitor, Teldec (a combination of English Decca and German Telefunken) in establishing London as a name to be reckoned with on these shores. Then in 1958, EMI went a step further by purchasing the American firm of Capitol and combining Angel with it.

The same pattern has obtained for the newest of the international giants, Philips of Holland, which made its entry on the American scene in late 1953 via the Epic label, created especially by American Columbia as part of an exchange agreement. But since the first of 1962, Philips has followed the EMI example of buying an American company, in this instance Mercury, which now issues records under both the Mercury and Philips imprints.

Deutsche Grammophon Gesellschaft, the German firm, also made its LP debut over here through a 1951 exchange arrangement with American Decca. But by the fall of 1959, DGG felt the need to establish its own identity in America, too, and so began issuing releases on the Deutsche Grammophon label, at first in Decca pressings, but subsequently in imported pressings. Since early this year, DGG has switched its American sales affiliation from Decca to MGM.

A special case among international combines is that of Artia-Parliament, an American firm that makes available both on its own





## *crunch*

Apples taste better when you're six years old. What's more they *sound* better. Those crunching noises reverberating through your head are exciting. You keep wondering if they can be heard on the "outside." Remember?

Naturally, you'll never hear an apple like that again. But if you've retained even a little sonic sensitivity, we can offer you an experience almost as pleasant.

Make your next recording on Audiotape.

You'll find that the wonderful quality of this tape provides more clarity, more range, eliminates noise and distortion

problems. And you'll find this quality is consistent from reel to reel and within every reel of Audiotape.

Whether you're taping a small apple-cruncher or a great symphony orchestra, there's an Audiotape exactly suited to your needs. From Audio Devices, for 25 years a leader in the manufacture of sound recording media—Audiodiscs\*, Audiofilm\* and . . .

**audiotape**  
TRADE MARK

AUDIO DEVICES INC., 444 Madison Ave., N.Y. 22, N.Y.  
Offices in Los Angeles, Chicago, Washington, D.C.

CIRCLE NO. 6 ON READER SERVICE CARD

\*TRADE MARK



# ARE YOU BEING CHEATED?

We at GRADO are constantly asked "How does a consumer know which ads are truthful?" "How can the consumer be sure that what he buys is really good?" "What protection does the consumer have after he spends his money?" He couldn't be sure until now!

**100% CONSUMER PROTECTION.** Proof of GRADO integrity and superb product quality is what we offer you with absolutely no risk on our part!!

## GRADO SENATOR CARTRIDGE A Genuine Moving Coil Stereo Cartridge \$24.95

**CERTIFIED SPECIFICATIONS.** After carefully controlled Laboratory tests the New York Testing Laboratories certifies the following specifications to be completely accurate. (Note: These specifications will be recertified at various intervals to assure you, the consumer, of consistent quality).

### SPECIFICATIONS — CERTIFIED (New York Testing Laboratories)



**FREQUENCY  
RESPONSE:**  
20CPS—1KC—  
±1DB  
1KC—10KC—  
±1.5DB  
10KC—22KC—  
±2DB

**APPLICATION:**  
Tone Arm or  
Record Changer  
Excellent for  
Monaural Records

**CHANNEL  
SEPARATION:**  
Vertical—Lateral  
30DB—1KC  
18DB—15KC  
45°—45° } 1KC  
30DB } 15KC  
14DB }  
Output—  
8MV @ 10CMV  
Tracking Force—  
3 grams  
Diamond Stylus

**ONE YEAR UNCONDITIONAL GUARANTEE** (From date of purchase). If the cartridge becomes defective for any reason (including children) you will receive a brand new cartridge FREE!!

**5 YEAR DIAMOND STYLUS GUARANTEE.** If the diamond wears from playing within 5 years of the purchase (even in a record changer) GRADO will replace it FREE!!

**ADDITIONAL PROTECTION.** You may return the cartridge to your dealer for a full refund if you are not completely satisfied after ten days of close listening in your own home.

### THE EXPERTS SAY:

"Provided a tape like stereo effect with no instrument wander."  
Larry Zide . . . American Record Guide  
"Superb sound at any price."  
Chester Santon . . . Adventures in Sound, WQXR

If the cartridge becomes defective after the warranty period expires, for a flat fee of \$15.00, you will receive a brand new cartridge.

**ONLY GRADO CAN BE PURCHASED WITH COMPLETE SECURITY!!**

The above guarantee also covers:

Laboratory Stereo Cartridge \$49.50 • Classic Stereo Cartridge \$37.50

For Ultimate Results Use The **TOP RATED** Laboratory Series Tone Arm \$39.50

ASK YOUR DEALER ABOUT THE **GRADO DUSTAT \$6.95**  
**VELVET TOUCH RECORD CLEANER • NO MESSY FLUIDS**

FOR FURTHER  
INFORMATION WRITE: **GRADO LABORATORIES, INC.**  
4614 Seventh Ave., Brooklyn 20, N. Y. • Export—Simonfrice, 25 Warren St., N.Y.C.

domestic pressings and by direct import (on the MK, Supraphon, and Qualiton labels) the product of the government-owned record trusts of the Iron Curtain countries.

Just as the great European record companies are seeking to engage the awareness of the American buyers, so our own firms are battling for their share of the overseas market from Rio to Tokyo, from Iceland to New Zealand. In some instances, this is being done through cooperation with one of the international combines but with insistence that the identity of the American label be retained. A current result of this type of operation is the new CBS label, which Columbia has established abroad to promote its corporate image on a world-wide basis.

This jockeying of international record colossi has begun to make its effect felt in the American classical-record market, if only because the great promotional and sales power of the international combines puts a terrific squeeze on the smaller independent (and often more enterprising in terms of repertoire) labels. Those that specialize in such fields as folk songs, spoken word, or musi-



cal esoterica are least affected; but those whose catalogs impinge on areas covered by the giants find the competition getting ever more rough. To deal with this problem, some independents have entered into loose federations that allow them some of the benefits of big-company promotion and sales. The affiliation of Command and Westminster with ABC-Paramount is a prime example.

Whether the current trend toward domination of the disc market by the international giants, with the almost inevitable resultant restriction of independent companies to specialty areas, is good or bad from the classical-repertoire standpoint depends in large measure on whether the American buyer will be treated to an abundance of superior records or whether he is to be restricted to endless duplication of standard repertoire, indifferently performed, and with variable engineering. At this point, we can only hope for the best.



# Don't buy it just because it's the world's best seller.



(There are 7 better reasons for choosing the Fisher 500-B integrated stereo receiver.)

1. All-in-one design: FM Stereo Multiplex tuner, stereo control-preamplifier and stereo power amplifier, all on one superb chassis, only 13½" deep by 17½" wide by 5¾" high. Just connect a pair of speakers and it's ready to play!
  2. Ultrasophisticated wide-band FM Multiplex circuitry, with 0.7 microvolts sensitivity for 20 db quieting at 72 ohms (2.2 microvolts IHFM Standard), four IF stages, absolute stability.
  3. Exclusive Stereo Beam indicator, the ingenious Fisher invention that shows instantly whether or not an FM station is broadcasting in stereo.
  4. High undistorted audio power: 65 watts IHFM Standard stereo music power at less than 0.8% distortion.
  5. Master control-preamplifier section of grand-organ versatility and simplicity.
  6. Magnificent styling, with architectural brass-finish control panel and beautifully finished walnut or mahogany cabinet.\*
  7. The Fisher name. (No comment necessary.)
- Price, \$359.50.\* The Fisher 800-B, virtually identical but also including a high-sensitivity AM tuner, \$429.50.\*

FREE! \$1.00 VALUE! Write for the 1962 Fisher Handbook, a 40-page illustrated reference guide, idea book and component catalogue for custom stereo installations.

Fisher Radio Corporation  
21-37 44th Drive  
Long Island City 1, N. Y.

Please send free 40-page Handbook, with complete specifications on the 500-B and 800-B.

Name \_\_\_\_\_

Address \_\_\_\_\_

City \_\_\_\_\_ Zone \_\_\_\_\_ State \_\_\_\_\_

02701



\*Cabinets \$24.95 extra. Prices slightly higher in the far west. Export: Fisher Radio International, Inc., Long Island City 1, N. Y. Canada: Tri-Tel Associates, Ltd., Willowdale, Ontario, Canada



# LETTERS TO THE EDITOR



**the  
Concord  
880  
is for  
connoisseurs\***

If you're going after top results in stereo tape you'll want to meet the Concord 880. There isn't a unit 4-track stereo recorder that can match the 880's important professional features. 3 heads, 3 speeds, 2 separate speakers, sound-on-sound, computerized tracking, dual VU meters and many other big advantages in achieving professional standards in stereo recording and playback. Enjoy the luxury of listening to the Concord 880 soon. Certainly before you invest in any tape recorder. And write for your copy of the specification brochure "All The Facts." Priced under \$400.

\* Connoisseur—Star of Danny Thomas CBS TV show sponsored by General Foods.

**CONCORD 880**  
—CONCORD ELECTRONICS CORPORATION

809F N. Cahuenga Boulevard, Los Angeles 38.  
CIRCLE NO. 13 ON READER SERVICE CARD

## Music Festivals

● Having attended quite a few European music festivals, I was interested in Joseph Wechsberg's observations on "The Festival Merry-Go-Round" in the April issue. I agree with Mr. Wechsberg that one is not likely to find more devoted performances of Wagner than at Bayreuth, though my enjoyment of them is lessened by the presence of the surviving members of the Master Race, for whom the Bayreuth festivals serve as a kind of class reunion.

The Salzburg festival has become a three-ring circus that the city just isn't big enough to contain. Last year I was unable to find a room within thirty miles of the city. No matter how magnificent the music, something is wrong when exquisite Baroque squares are turned into parking lots. It was a relief to see Salzburg revert to its delightful normal self when the festival was over.

In my experience, the most enjoyable music festivals are those in Vienna and Lucerne, largely because these cities maintain a relaxed pace that is congenial to the enjoyment of great music.

SHEA COHALLAN  
New York, N.Y.

● Joseph Wechsberg has written a delightful article on European festivals, but I am afraid that to some extent he has allowed whimsy to conquer truth. He implies that many of these festivals are dreamed up solely for commercial reasons, and he unfortunately selects the Schwetzingen Festival as a typical example, going on at some length to prove that the sale of asparagus is the motivating reason of the festival.

Whatever the case may be today, both Mr. Wechsberg and your readers may be interested to know how the festival came into being. The year was 1946, one of the dreariest in German history. I had just been assigned to the Heidelberg area as Theater-and-Music Control Office of the Military Government. My immediate superior was Newell Jenkins, well-known on records as conductor of the Italian Chamber Orchestra and in those days Chief of Theater and Music Control for Wuerttemberg-Baden.

As soon as he knew where I would be stationed, Newell (who was familiar with Germany from prewar days) urged me to drive out to nearby Schwetzingen and inspect the beautiful little roccoco theater located in the palace.

This little gem can seat only 420 persons, but with an auditorium which is only 40 feet deep, it boasts a stage almost 100 feet deep. Designed for the operatic requirements of the eighteenth cen-

tury, for which it is the most ideal frame I know, I immediately said to myself that this was the ideal place to do *The Magic Flute*. And with that the Schwetzingen festival was born.

It would seem clear, then, that the sole motivating reason for the Schwetzingen festival as it was originally conceived was one of pure art for art's sake, and with no commercial afterthoughts. Since leaving Germany in 1950, I've lost track of what is being performed there. I can only hope that the performances are as good as the asparagus.

JEROME J. PASTENE  
Dover, Mass.

## What is Basic

● I do not presume to question Martin Bookspan's taste in his selection of the preferred recordings of "The Basic Repertoire," but it does seem to me that the selection of the repertoire itself is lopsided in favor of the Romantic composers. Among the first thirty-five selections of what is to constitute the "Basic Fifty" I cannot sanction the inclusion of seven works by Beethoven, five by Brahms, five by Tchaikovsky, and eight more by other Romantic composers, while the Baroque, classic, and contemporary eras are neglected. Should not a basic repertoire represent a cross-section of great music of all times?

PAUL R. MILLER  
Short Hills, N. J.

*Mr. Bookspan chooses works for review in his "Basic Repertoire" series partly on the basis of their representation in the record catalogs, feeling that it is of primary importance to help the reader select recordings of works that are available in a considerable number of versions—sometimes actually forty or more.*

*The concentration on works of the Romantic period simply reflects the state of the record catalogs and presumably that of public taste.*

## Three for the Price of One

● In Floyd St. Clair's excellent survey of language-teaching records "From Aal to Zut" (April, 1962), he lists the price of the Dover "Listen and Learn" sets as \$17.85. Possibly he thought that each disc in the set costs \$5.95. The fact is that the entire set, consisting of three 12-inch LP records plus the printed material, sells for \$5.95.

This unusual value may have led Mr. St. Clair to believe that our language sets sell for three times as much as they actually do.

HAYWARD CIRKER, President  
Dover Publications, Inc.  
New York, N.Y.



Honest weight, accurate weight—they're one and the same. People have come to look upon counterbalanced scales as assurance of accurate weight. And for good reason, too.

Springs are uncertain. They expand with heat, and contract with cold. The more you extend a spring, the more it pulls back. With every change of extension, there's a change in pulling force. Pick-up arms that use springs are susceptible to these changes. When several records are stacked on the turntable, the arm is raised; the length or extension of the spring is altered; the pulling force changes, and consequently, the force of the stylus changes, too. With warped records, the arm is constantly rising and falling, and the stylus force is constantly changing.

The Miracord-Studio arm uses no springs. It is like a fine apothecary or chemist's scale—mass-balanced, and freely suspended on low-friction bearings. Stylus force is set by shifting the mass of the counterbalance. Once set, this stylus force remains constant with one or with ten records on the platter.

During actual play, the Miracord-Studio arm is completely disengaged from the automatic mechanism. It responds freely and effortlessly without the slightest trace of friction or drag.

Location of the pivot at almost the level of the record surface minimizes wow due to warped records. Tracking error geometry is at an absolute minimum—zero degrees at 2-inch radius, and slightly over 1 degree at 6 inches—and there are no resonant peaks within or even beyond the audible spectrum.

Unlike other transcription arms, you don't have to buy the Miracord-Studio separately. It is an integral part of the Miracord, the only record playing instrument with a dynamically balanced turntable and mass-balanced transcription arm which you can play manually or as automatically as you please.

Miracord 10H with hysteresis-synchronous motor is \$99.50; the Model 10 with 4-pole induction motor, \$89.50. Prices include arm, but do not include the cartridge and base.

Make it a point to see the Miracord at your high fidelity dealer, soon—or write for new 6-page descriptive catalog.



**MIRACORD**

BENJAMIN ELECTRONIC SOUND CORP., 97-03 43RD AVENUE, CORONA 68, NEW YORK • SOLE U.S. DISTRIBUTOR FOR ELECTROACUSTIC® RECORD PLAYING COMPONENTS

**HONEST  
WEIGHT  
NO  
SPRINGS**

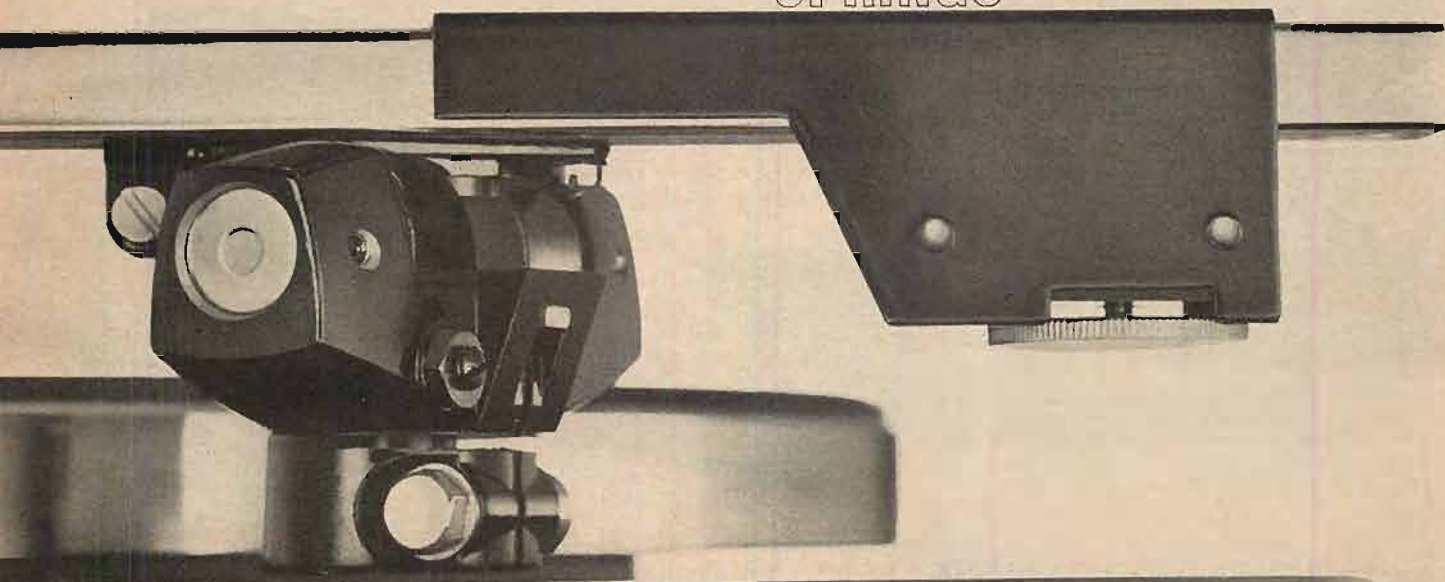



Now is the time  
to come to the aid  
of your party!  
*outdoor*

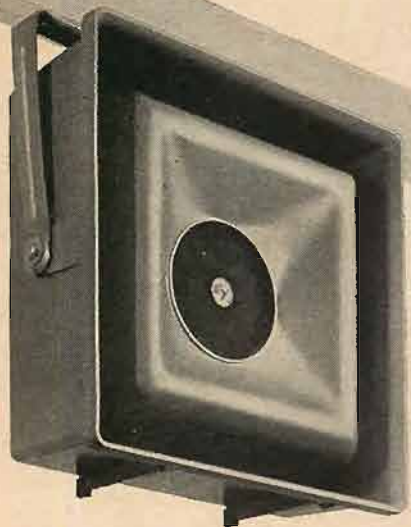

**Electro-Voice®**

High-Fidelity Speaker System  
...it's Weather-Proofed!

Now you can easily add the luxury of high-fidelity music to your outdoor fun!

Whether you're dancing under the stars, swimming in the pool or relaxing around the barbecue... the new Electro-Voice Musicaster provides high-fidelity music from your present hi-fi system, radio, phonograph or TV set.

Specially designed for indoor-outdoor use, the E-V Musicaster features a heavy-duty weather-proofed speaker mounted in a rugged aluminum die-cast enclosure. It's easy to connect for permanent use outside. And you simply move it into the recreation room for year-round pleasure.

Send now for full information... plus the name of your nearest E-V sound specialist!

The E-V Musicaster® is also a "sound" buy for church, school, or club!



ELECTRO-VOICE, INC., Buchanan, Mich.

ELECTRO-VOICE, INC., Dept. 724F  
Buchanan, Michigan  
Please send me your free booklet, "How to Enjoy High-Fidelity Outdoors" and E-V sound specialist list.

Name \_\_\_\_\_  
Address \_\_\_\_\_  
City \_\_\_\_\_ State \_\_\_\_\_

CIRCLE NO. 18 ON READER SERVICE CARD

## just looking

...at the best in new hi-fi components

● **Audio Originals** announces the Model 303 stereo cabinet, which provides spaces for tuner, amplifier, turntable or changer, and two compact

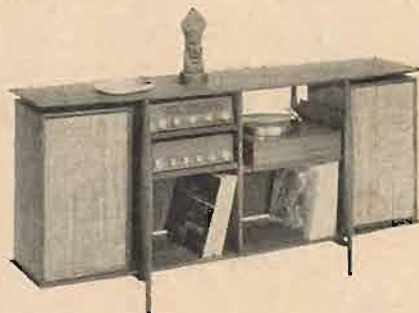

speaker systems. Over-all dimensions are 72½ x 32½ x 16 inches. Speaker compartments are 25¾ x 16¾ x 16 inches. The Model 303 is available in oiled walnut, fruitwood, cherry, and mahogany finishes. Price: \$99.50. (Audio Originals, 474 South Meridian Street, Indianapolis 25, Ind.)

circle 176 on reader service card

● **Dynaco** now offers a stereo adapter kit, the Model FMX-3, that fits on the chassis of the FM-1 Dynatuner. Automatic in operation, the FMX-3 provides identical signals on both channels in mono reception and 30 db stereo separation if a stereo broadcast is tuned in. Incoming stereo signals light up an indicator on the front panel.

Alignment can be accomplished by the kit builder without the use of test equipment, and construction time is estimated at three hours. Price: \$29.95 (FMX-3 kit). The stereo Dynatuner is also available factory-assembled for \$169.95. (Dynaco, Inc., 3912 Powelton Avenue, Philadelphia 4, Pa.)

circle 177 on reader service card

● **Lafayette** introduces a four-track mono tape recorder, the RK-137, that also plays back prerecorded stereo tapes



through external playback equipment. The RK-137 operates at either 7½ or 3¾ ips. Frequency response is 40 to 15,000 cps; wow and flutter are less than

0.3 per cent; and the signal-to-noise ratio is 42 db. Outputs are provided for an external speaker, monitor phones, and for an external amplifier. Weight: 21 lbs. Dimensions: 13½ x 6½ x 10⅝ inches. Price: \$89.50. (Lafayette Radio Electronics Corp., 111 Jericho Turnpike, Syosset, Long Island, N. Y.)

circle 178 on reader service card

● **Transis-Tronics** introduces the Model 320, which comprises the transistorized S-15 stereo amplifier and FM-15MX stereo tuner mounted in a cabinet that includes provisions for installing a record changer or turntable. All components are concealed behind hinged panels, and the unit is unusually com-



compact. Dimensions: 23 x 14 x 15¼ inches. Price: \$428.50. (Transis-Tronics, Inc., 1601 Olympic Blvd., Santa Monica, Calif.)

circle 179 on reader service card

● **Zenith** offers a portable AM-FM transistor radio, the Royal 2000, that is powered by eight flashlight batteries.



The Royal 2000 operates through a 7 x 5-inch oval speaker. A headphone jack, an AM loopstick, and a telescoping FM dipole antenna are provided. The unit can be used as an AM-FM tuner by the incorporation of an adapter, furnished at additional charge. Weight: 11¾ lbs. (with batteries). Dimensions: 11⅝ x 10⅜ x 4⅞ inches. Price: \$149.95. (Zenith Radio Corporation, 6001 Dickens Avenue, Chicago 39, Ill.)

circle 180 on reader service card



# ONLY THE ROBERTS 1040

## WITH "HARMONIZER" MAGI-CABLE



**LUCILLE BALL:** "My advice to anyone who wants to improve his musical or speaking ability is to use a Roberts 1040 tape recorder for rehearsal."



**LAWRENCE WELK:** "My Roberts 1040 tape recorder is the closest to recording studio equipment that I have seen."



**STAN KENTON:** "Leaves nothing to be desired in terms of recording and playback quality—really unbelievable at \$299.50!"



▲ Danny—big for his 4½ years—and his accompanist are shown making a basic recording of "Farmer in the Dell"—using the 1040 in normal record mode.

Now the "Magi-Cable" has been installed for sound-on-sound transfer on the 1040. Danny says that four-and-a-half is NOT too young to learn how to harmonize. ▼

Offers Multiple sound-on-sound recording on a single Stereophonic Tape Recorder (Sound with Sound, too!)



# ONLY THE ROBERTS 1040

## COMBINES THESE ADVANCED FEATURES

Records New FM MULTIPLEX STEREO CASTS • 4-track stereo and monaural record/play • 2-track stereo and monaural play • Sound-with-sound, using either track as basic track • Dual, self contained power stereo amplifiers • Dual, built-in extended range stereo speakers • Automatic shut-off.

**\$299<sup>50</sup>**

**ROBERTS ELECTRONICS, INC.**  
LOS ANGELES 16, CALIFORNIA



INTERNATIONAL SALES: Joseph Plasencia, Inc., 401 Broadway, New York 13, New York—Cable: UNIONTEX  
ROBERTS CANADA: 2810 Victoria Drive, Vancouver, B.C.  
Prices slightly higher in Canada

*Roberts Never Discounts the Value of the Best in Music Reproduction*

ROBERTS ELECTRONICS, INC., Dept. HFSR-7-L  
5920 Bowcroft Ave., Los Angeles 16, Calif.

Please send me:

- Roberts Stereo Tape Instruction Manual containing stereo and monaural applications. I enclose 25¢ (cash, stamps) for postage and handling.  
 The name of my nearest dealer.

Name \_\_\_\_\_

Address \_\_\_\_\_

City \_\_\_\_\_ Zone \_\_\_\_\_ State \_\_\_\_\_



**FOR FULL QUALITY  
STEREO-MULTIPLEX  
OR MONOPHONIC  
FM RECEPTION**

use

**FINCO**®

**World's most  
Complete Line of  
Hi Fi Phased  
FM Antennas . . .**

**The "Top-Rated" "Best Buy"  
FM ANTENNA LINE**

• No matter how well your FM unit is performing, you'll hear the difference a FINCO makes. Rich, luxurious distortion-free sound is yours when you pick just the right FM antenna from FINCO's complete line.

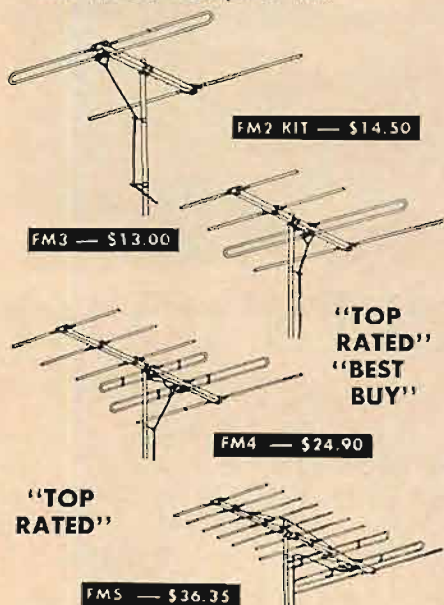

Plus FMT-1 Turnstile Kit — \$14.50

Write today for Catalog #20-213.

**FINCO**®  
**THE FINNEY COMPANY**

Dept. H.D.

34 W. Interstate Road Bedford, Ohio

CIRCLE NO. 19 ON READER SERVICE CARD

18



**BEGINNERS  
ONLY**

by HANS H. FANTEL

**I**N ADDITION to the familiar treble and bass controls, the front panels of many amplifiers have an additional tone control marked "Equalization." To use this control intelligently, it helps to have some understanding of the process by which records are made from the master tapes.

It is not possible to record a disc with the balance between bass and treble as it actually exists in music. The reason is that the bass notes contain so much acoustic energy that they would make the record groove swing over an amplitude too great to fit within the width normally allowed for the groove. Treble notes, on the other hand, contain so little acoustic energy that they would be overshadowed by surface noise if they were engraved in a record in their natural balance. To counteract these difficulties, the bass frequencies are reduced and the treble frequencies are emphasized when a record is cut.

In playback, therefore, to restore the natural balance between bass and treble, the bass frequencies must be emphasized and the treble frequencies reduced. This process is called equalization. In the early days of the long-playing record, recording engineers were in disagreement over how much the bass and treble ranges should be manipulated and at what frequencies the boost or cut should take place. This led to a number of different equalization standards. Since 1955, however, a single standard, the RIAA (Record Industry Association of America) equalization curve, has been in effect. In theory, all that is necessary to get correct tonal balance from any record made since 1955 is to set your equalization to "RIAA" and leave the bass and treble controls in the neutral position. In practice, however, this doesn't always work out, not only because there are differences in room acoustics but because record companies sometimes alter tonal balances in an effort to make the recording sound better. Some emphasize the treble, giving their records a brilliant sound. Others have a tendency to cut back on bass, presumably to make it easier for inferior equipment to track loudly recorded passages. Whatever the reasons, these alterations in tonal balance mean that you cannot always rely on the equalization control alone to give you neutral balance. It will give you a fair approximation, but often you still have to make touch-up adjustments with the treble and bass controls to achieve realistic sound from a given disc.

In addition to the RIAA setting, your amplifier may have other equalization positions, such as NAB, AES, LP, etc. These refer to various equalization curves that were used before the adoption of the RIAA standard. On many older discs, the record jacket tells you which setting to use. If your amplifier lacks the prescribed setting, you can usually come pretty close to it by leaving the equalization on RIAA and then adjusting the treble and bass controls until the record sounds balanced to your ears. Hearing, after all, is a subjective experience, and no standard equalization can please all listeners. So don't hesitate to assert your individuality via the tone controls. The correct setting is simply the one you like best.



*Heathkit<sup>®</sup>  
puts  
professional  
quality  
into new  
low cost  
stereo tape  
recorder*

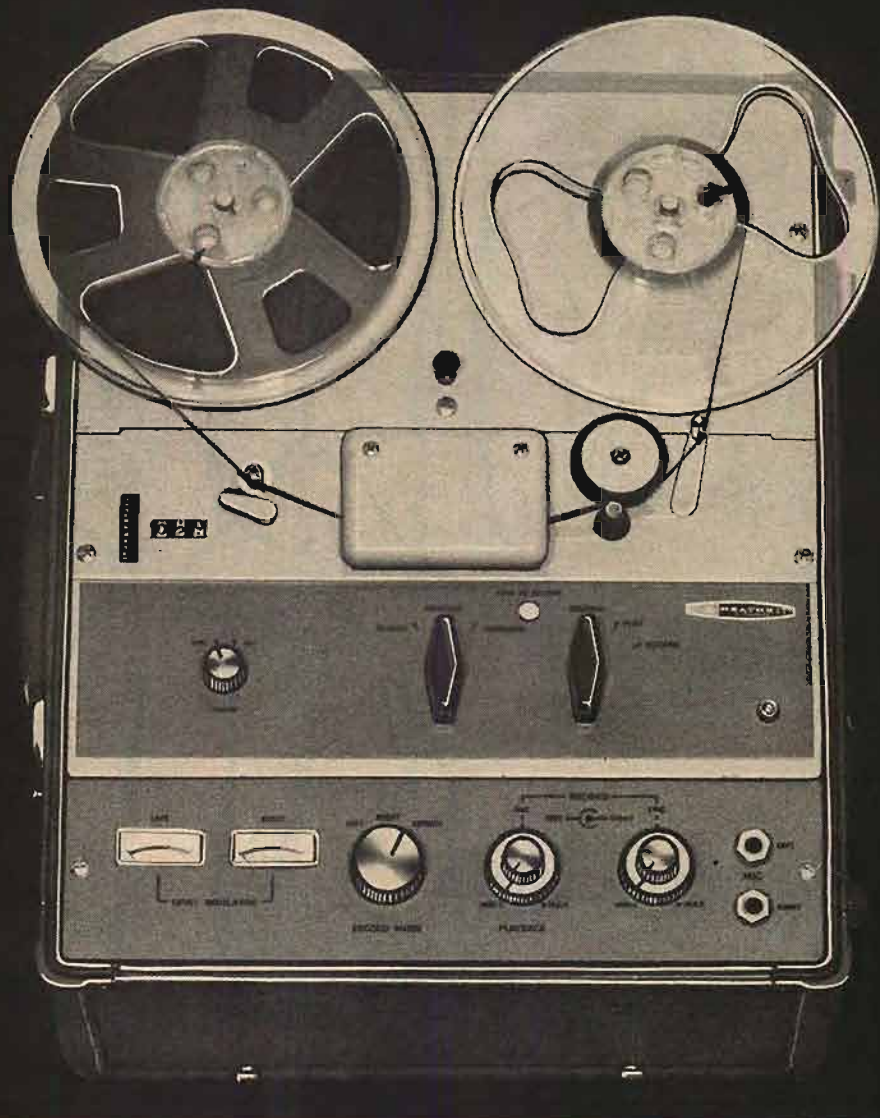

Here's the latest example of the Heath ability to give you more for less . . . the all new Heathkit 4-Track Stereo Tape Recorder. Its obvious quality yields professional results (less than .18% wow & flutter at 7½ ips). Its many extra features assure better, more convenient performance (see chart at right). Its fast, easy circuit board construction makes any tyro confident of technical excellence. Its versatility is remarkable . . . record and playback 4-track stereo tapes or playback 2-track monophonic tapes . . . use it as part of your stereo music system or as a portable. Choose your model now: the Model AD-12 provides the mechanism for playback of stereo or mono tapes (converts to a recorder later by adding the electronics) \$124.95; the model AD-22 includes both mechanism and electronics for stereo record and playback, \$179.95. Optional carrying case, \$37.50. Accessory ceramic microphones, \$9.95 ea.

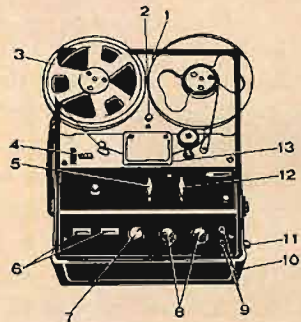

#### FEATURES

1. Die-Cast aluminum panel.
2. Speed change lever (7½ & 3¾").
3. Seven inch reel capacity.
4. Three-digit counter.
5. Fast forward—rewind lever.
6. VU-type level meters.
7. Stereo /Mono record switch.
8. Mixing level controls (mic. & line).
9. Microphone inputs.
10. Cathode-follower output jacks.
11. Line inputs.
12. Record-playback lever.
13. 4-track record-playback and erase heads.



**HEATH COMPANY**  
Benton Harbor 40, Michigan

Ordering Instructions: Fill out the order blank, include charges for parcel post according to weights shown. Express orders shipped delivery charges collect. All prices F. O. B. Benton Harbor, Mich. A 20% deposit is required on all C.O.D. orders. Prices subject to change without notice. Dealer and export prices slightly higher.

Enclosed is \$ \_\_\_\_\_; send \_\_\_\_\_

Name \_\_\_\_\_

Address \_\_\_\_\_

City \_\_\_\_\_ Zone \_\_\_\_\_ State \_\_\_\_\_





WOODCUT BY ARISTÈDE MAILLOL COURTESY BETTMANN ARCHIVE

## RAVEL'S *DAPHNIS AND CHLOË*

**D**URING the two decades before and after World War I the most vital performing organization in the world of the musical theater was undoubtedly the fabled Ballet Russe of Serge Diaghileff. Diaghileff had a positive genius for recruiting the collaborate efforts of the leading graphic, musical, and dancing artists of the day. The resulting confluence of creative endeavor produced a series of twentieth-century masterpieces that are still unparalleled in their utilization of talents from the various fields of art. For example, the following artists were responsible for the world-premiere presentation (in London in July, 1919) of the ballet, *The Three Cornered Hat*, based on the Spanish folk novel by Alarcón: Manuel de Falla, who composed the score; Pablo Picasso, who designed the scenery and costumes; Leonide Massine and Tamara Karsavina, who danced the leading roles;

and Ernest Ansermet, who conducted the performance.

Seven years earlier, an equally distinguished group of artists created for Diaghileff a ballet on the *Daphnis and Chloë* story by the fifth-century Greek author Longus. Maurice Ravel composed the music; Michel Fokine did the choreography; Leon Bakst created the sets; Nijinsky and Karsavina danced the leading roles; and Pierre Monteux conducted the performance. Another distinguished composer for Diaghileff, Igor Stravinsky, once wrote of *Daphnis and Chloë*: "It is not only Ravel's best work, but also one of the most beautiful products of all French music."

Ravel, being a classicist, was strongly drawn to the story of the Greek pastoral and its tale of the instinctive and uninhibited love between Daphnis, the shepherd, and Chloë, the shepherdess. And yet there is little of classical remoteness in the music; rather, there is



mirrored in its pages the essence of Ravel's art: elegant, polished, and sophisticated. John N. Burk has pointed out that this is not ancient Greece, but France, the France of Versailles, where simplicity was achieved in the most studied, elegant, and sophisticated manner possible.

Ravel, in an autobiographical sketch written in 1928, said of *Daphnis and Chloë*: "The work is constructed symphonically according to a strict tonal plan by the method of a few motifs, the development of which achieves a symphonic homogeneity of style." These words are especially pertinent in discussing the complete ballet score (as distinguished from the two concert suites that Ravel himself extracted from the larger work). The two suites, especially the second, have long been favorites of the repertoire, but in recent seasons conductors have been turning with increasing frequency to the complete score of the work for their concert performances.

**M**ORE than half a dozen recordings of the full ballet have been released during the past decade, and there are three stereo/mono editions of the work in the current catalog: Leonard Bernstein with the New York Philharmonic (Columbia MS 6260, ML 5660); Pierre Monteux with the London Symphony Orchestra (London CS 6147, CM 9028); and Charles Munch with the Boston Symphony Orchestra (RCA Victor LSC/LM 2568).

The Munch album is a recent rerecording (made in February of last year) of an interpretation that has constantly grown in refinement and sensitivity since the conductor first recorded the two suites for English Decca about fifteen years ago. *Daphnis and Chloë*, with its shifting colors, its violent contrasts, and languorous atmosphere, is a perfect score for the mercurial art of Charles Munch, and he has given us here one of the finest achievements of his career. The quality of sound is mellower than that in the deleted Munch-Boston Symphony recording of 1955 (RCA Victor LSC/LM 1893), owing to a more distant microphone placement, and the chorus is less to the fore. But the greater refinement and mystery of the new performance makes for a more poetic and—one is

reasonably certain—more authentic presentation of the music.

Monteux, for his part, is considerably more detached in his approach than is Munch. There is a quality of austerity in the Monteux performance that underlines the classical directness of the music. For those to whom understatement is the preferred ideal, Monteux's version will prove eminently satisfying. The sound is slightly more forward than in the second Munch recording, but in most essentials there is little to choose between the two in this regard. Munch, incidentally, in both his 1955 and 1961 recordings, takes over fifty-five minutes; Monteux takes just over fifty-one.

Bernstein, as might have been anticipated, draws much broader effects in the music than does either Munch or Monteux, and his recorded sound has more presence than that of the two rival editions. There is no denying the vigor and excitement of the Bernstein recording—and a special word of praise must be directed to the enthusiastic collaboration of the Schola Cantorum of New York—but the atmosphere and aesthetic of *Daphnis and Chloë* are more authentically communicated by the two older conductors. Bernstein, like Monteux, takes about fifty-one minutes for the performance, yet his tempos seem considerably more rushed at times.

Many recordings are available of the Second Suite alone, coupled with other miscellaneous material, but strangely there is apparently no longer any recording available of just the First Suite. Most of the Second Suite recordings omit the brief part for the wordless chorus in the *General Dance* (the Second Suite is actually Part Three of the ballet), but there are a few that do include it. Of these, probably Command's edition (11005 SD, 11005) with Pierre Dervaux conducting the Colonne Orchestra of Paris will please the majority of listeners. The recorded sound is superb, with remarkable clarity and definition of timbres, and Dervaux leads an idiomatic performance. Carlo Maria Giulini's version (Angel S 35820, 35820), of the recordings that omit the choral portions in the Second Suite, seems to me the most consistently worthwhile, and it gains from really superlative playing from London's Philharmonia Orchestra.



Charles Munch's recent recording of *Daphnis and Chloë* for RCA Victor is one of the great achievements of his career, while Pierre Monteux, on the London label, offers an ideal reading for listeners who prefer a more classic style. Pierre Dervaux's *Second Suite* for Command is idiomatic and is noteworthy for its sonic brilliance.



# all-transistorized New Sony Sterecorder 777



**the first/complete/portable/all-transistorized/high fidelity PROFESSIONAL RECORDING & PLAYBACK SYSTEM**

The most advanced achievement in recorder engineering to date, the superb new remote-controlled professional Sterecorder 777 series features the exclusive and patented Sony Electro Bi-Lateral 2 & 4 track playback Head, a revolutionary innovation that permits the playback of 2 track and 4 track stereophonic or monophonic tape without track width compromise—through the same head!

Included in an array of outstanding features are individual erase/record/playback heads, professional 3" VU meters, automatic shut-off, automatic tape lifters, an all-solenoid, feather-touch operated mechanism, electrical speed change, monitoring of either source or tape, sound on sound facilities, and an all-transistorized military plug-in type circuitry for simple maintenance. The three motors consist of one hysteresis synchronous drive motor and two hi-torque spooling motors.

Unquestionably the finest professional value on the market today, the 777 is available in two models, the S-2 (records 2 track stereo) and the S-4 (records 4 track stereo). Both models can reproduce 2 and 4 track tapes.\* And, the Sterecorder 777 models will integrate into any existing component system. \$595 complete with portable case and remote control unit.

\*Through the exclusive Sony Electro Bi-Lateral 2 and 4 track playback head.

Sony has also developed a complete portable all-transistorized 20 watt speaker/amplifier combination, featuring separate volume, treble and bass controls, mounted in a carrying case that matches the Sterecorder 777. \$175 each.

Also available is the MX-777, a six channel all-transistorized stereo/monophonic mixer that contains six matching transformers for balanced microphone inputs and recorder outputs, individual level controls and channel selector switches, Cannon XL type receptacles, a switch to permit bridging of center staging solo mike. \$175 complete with matching carrying case.

The first/complete/portable/all-transistorized/high fidelity/professional recording & playback system: \$1120 complete.

Sold only at Superscope franchised dealers. The better stores everywhere.

For additional literature and name of nearest franchised dealer write Superscope, Inc., Dept 8 Sun Valley, California.

All Sony Sterecorders  
are Multiplex ready!

**SUPERSCOPE**

The Tapaway to Stereo





# TECHNICAL TALK

by JULIAN D. HIRSCH



**W**HEN THE present system of stereo disc recording was introduced a few years ago, its compatibility with the existing monophonic system was extensively publicized. A stereo cartridge would not only play stereo records but mono records as well.

Anyone who has followed the progress of stereo disc reproduction is aware that the early stereo pickups were inferior to the better mono pickups of the day, particularly in respect to frequency response and distortion. Great improvements have been made since then, and most current stereo cartridges are clearly superior to the finest mono cartridges of three years ago.

The key factor in stereo-mono compatibility is that the sum of the left- and right-channel information corresponds to purely lateral stylus motion. Playing a laterally cut mono record monophonically with a stereo pickup yields an output equivalent to that from a stereo record with the vertical modulation removed. Also, a bonus in signal-to-noise ratio results from paralleling the two outputs of the stereo cartridge when playing mono records. This cancels rumble and noise components that are caused by vertical stylus motion.

But many listeners, including myself, have observed that the apparent high-frequency response of a stereo cartridge is often reduced when its outputs are paralleled. When this occurs, it is usually possible to make an audible improvement by playing the record with the amplifier set to the stereo mode, even though this may increase the rumble level. The extent to which there is an improvement varies widely with the particular cartridge and record being used. I can find no meaningful correlation between the quality of a cartridge and its loss of highs when its outputs are paralleled.

My first theory was that this effect was caused simply by a reduction in record hiss and high-frequency distortion when the cartridge's vertical response was cancelled. Careful listening revealed that, while this was part of the story, there was also a definite deadening of high frequencies on the program material. A second possible explanation was that the two outputs from the stereo cartridge had a phase difference that produced partial cancellation of high frequencies. In general, however, frequency-response measurements with and without the parallel connection do not fully confirm this theory.

To be perfectly honest, I cannot explain this effect in terms of any single cause. I suspect it is due to a combination of the factors I have mentioned, and possibly others as well. It is certainly a very real and discernible phenomenon, however, and I would suggest that the stereo playback mode be tried when playing mono records with a stereo pickup. If your turntable has reasonably low vertical rumble, you may hear a worthwhile improvement in sound.

Incidentally, there is one other consideration involved here. Most earlier LP records were designed to be played with 1-mil styli. Stereo pickups generally have 0.7- to 0.5-mil styli and may rattle around in the bottom of a mono groove and cause distortion. If this is the case, for best reproduction it is advisable to use a good mono pickup to play these older records.

## CABINART MARK II SPEAKER



● AT A TIME when most speaker systems sell for over \$100.00, it is interesting to come across a system priced at only \$27.00. The Cabinart Mark II, similar in size and shape to most popular bookshelf systems, has an advertised frequency response of 40 to 15,000 cps, a power-handling capability of 15 watts, and an impedance of 8 ohms.

The Mark II's enclosure is made from  $\frac{3}{4}$ -inch pressed-wood composition board, and its glued joints are accurately mitred, there being no visible gaps along any of the joints. The surface (sanded smooth) is fairly attractive without further finishing, and it can be painted if such is desired. The system is also available in a walnut veneer finish for \$43.20.

Acoustically, the Mark II is a ducted-port design, with a duct at each end. The sides and rear of the box are covered with absorbent material to damp resonances. The speakers are a 12-inch woofer cone and a 3-inch coaxially mounted tweeter.

In my tests, I drove the system with a constant 10-watt input from 20 to 1,000 cps, reducing power to 1



watt above 1,000 cps to prevent damage to the tweeter. The response curves obtained at eight microphone positions were averaged to obtain a composite curve. This curve showed a peak of 8 db at 150 cps and another of 8 db at 1,500 cps, with otherwise quite uniform response between 100 and 4,000 cps. The output dropped off below and above these limits, with another 8-db peak at 8,000 cps and smaller peaks at 40 and 70 cps. The low-frequency harmonic distortion remained low (under 4 per cent) down to 70 cps, and tone-burst tests revealed fairly good transient response, comparable to that of some much more expensive speaker systems.

The measurements largely confirmed my subjective evaluation of the Mark II in listening tests. It seemed to have a bright, rather hard sound, with little feeling of bass content. The brightness is evidently due to the peak at 8,000 cps rather than to an extended high-frequency response. There is a strong sense of projection from the 1,500-cps peak and a bit of boxiness on male voices from the 150-cps peak.

The over-all effect of the Mark II is not unpleasant if the volume is kept at reasonable levels, but the fact of the matter is that this speaker lacks the smoothness I like in my musical reproduction. On the other hand, it is not fair to make a statement like this without at the same time noting that the Mark II sells for about one quarter of the price of most popular speaker systems. Considering this, I would say that the Mark II is a good value, and I believe it would be perfectly satisfactory for use as an extension speaker.

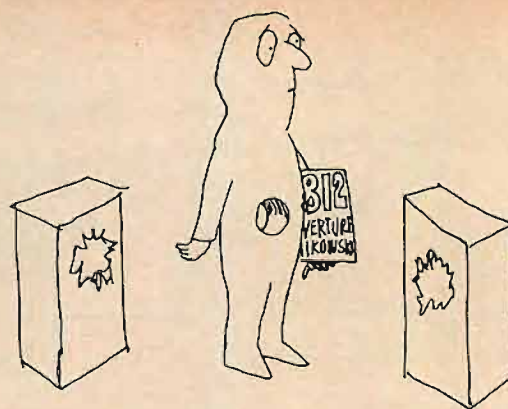

JERRY MARTIN

RIAA record-playback equalization to approximate the tape-playback characteristic.

The tuner dial is large and quite legible. Calibration is at 2-megacycle intervals, which, incidentally, is a bit too infrequent for my liking. A neon bulb behind the dial plate glows when the input is set to FM, and another bulb lights up when a station that is tuned in is transmitting in stereo.

The amplifier section of the Pilot 654M delivered 25 watts per channel (continuous) at 2 per cent distortion at middle frequencies, and over 20 watts per channel at 20 and 20,000 cps. This is very good performance for a moderate-price amplifier, especially when one considers that both channels were being driven simultaneously. IM distortion was 0.4 per cent at 5 watts per channel, 0.8 per cent at 10 watts per channel, and 2 per cent at 22 watts per channel.

Over-all frequency response, tone-control action, and filter action were all good, except that I felt that the filters were too gradual in their effect and removed too much program material. The amplifier gains were high, yet hum levels were quite low (completely inaudible, in fact). The stereo crosstalk was -34 db at 1,000 cps.

The FM tuner section of the 654M had an IHFM usable sensitivity of 5 microvolts. For signals over 100 microvolts, distortion was under 0.5 per cent at 100 per cent modulation (unusually good). The tuner had virtually no drift and a 3.5-db capture ratio (very good). This is important for reducing distortion from multipath reception of FM stereo signals. The tuner hum was very low, measuring 58 db below 100 per cent modulation.

The stereo demodulator is of the switching type, simple yet effective. The channel separation was about 30 db up to 2,000 cps, falling to 18 db at 10,000 cps and 10 db at 15,000. These measurements are very good and are comparable to the best stereo cartridges. Frequency response in stereo was essentially the same as in mono:  $\pm 1.4$  db from 20 to 15,000 cps.

In use, the Pilot 654M performed very well. It was easy to tune and gave quiet, undistorted, and audibly excellent reception of both stereo and mono FM broadcasts. The stereo-indicator light was quite effective and was not triggered by interstation noise.

The 654M costs \$329.50, including metal cabinet.

#### PILOT 654M STEREO TUNER- AMPLIFIER



● PILOT has handled the transition from AM-FM stereo to FM stereo very neatly in their Model 654M tuner-amplifier. The AM section of the earlier Model 654 has been replaced by a multiplex demodulator, and minor modifications have been made in the circuitry of the FM section. The amplifier sections appear to be unchanged, and are rated at 30 watts per channel (music power).

The 654M is a handsome and flexible unit and is pleasingly free of gadgetry. I particularly liked its functional control layout. The tone controls are normally ganged for both channels, which is preferable if identical speakers are used. An easily removed locking pin converts them into separate concentric controls. The two phono inputs, selectable by a separate knob, are identified as RC and TT. The RC input is designed for the higher-output cartridges commonly used with record changers. Actually, it has enough gain for practically any good magnetic cartridge. The TT input has more gain, and can be driven from a low-output cartridge or directly from a tape-playback head. In the latter case, the bass tone control is used to modify the





THE WORLD'S MOST FUNCTIONAL PACKAGE

UNTIL NOW



## THE REMARKABLE NEW AWARD KITS BY HARMAN-KARDON

The perfect blend of form and content. This is the unique achievement of the Award Kit Series.

There's sheer pleasure in just looking at the kit: in seeing how each component is packed precisely in the sequence in which it will be used; how the unique tool-box packaging, with pull-out trays, makes handling and identification easy.

An extraordinary instruction book lends a dimension never before available in a high fidelity kit. It contains simple, interesting explanations of how each section of the instrument works. For the first time the kit builder understands just what he is doing—as he is doing it. The handsome book is easeled, spiral-bound and provides complete integration of diagrams and text.

No detail has been overlooked in the creation of this exciting product group. Here is the electronic perfection and incompara-

ble performance of the famed Award Series; the total integration of the most advanced instruction material, packaging and construction techniques. From the moment you open the kit, until the final moment when the completed instrument is turned on, yours will be a totally gratifying experience.

The Award Kits include: Model A30K—handsome 30 watt integrated stereo amplifier kit—\$79.95. Model A50K—powerful 50 watt integrated stereo amplifier kit—\$119.95. Model F50XK—professional FM Stereo (Multiplex) tuner kit—\$129.95. All prices slightly higher in the West.

For more information write Dept. R-7, Harman-Kardon, Inc., Plainview, New York.

**harman kardon**

CIRCLE NO. 23 ON READER SERVICE CARD



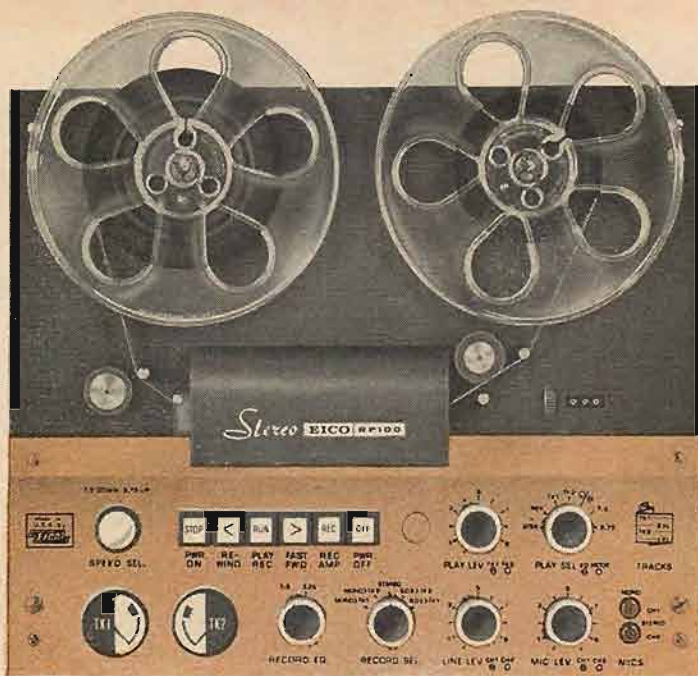

# 9 New Features Now In The New 1962 EICO RP100 Transistorized Stereo/Mono 4-Track Tape Deck

### A great tape recorder made greater:

1. New professional studio recording hysteresis-synchronous capstan motor: 24 stator slots for ultra-smooth drive, ultra-quiet and vibrationless professional bearing system.
2. Two new take-up and rewind reel motors, both extra-powered for effortless operation.
3. New cored-out steel capstan flywheel with all the mass concentrated at the rim for improved flutter filtering.
4. New optimally designed capstan drive belt brings wow down to negligibility.
5. New relay provides instantaneous extra power to the take-up reel motor at start to minimize tape bounce. Provides near-perfect stop-and-go operation and eliminates any risk of tape spillage when starting with a nearly full take-up reel.
6. New automatic end-of-tape stop switch cuts off take-up reel motor power. Also permits professional editing techniques, whereby tape being edited out runs off the machine while you are listening to it.
7. Playback preamps remain "on" during stop-standby mode to permit cueing.
8. Recording level adjustment during stop-standby.
9. Shock-absorbent helical spring tape lifters practically eliminate tape bounce at start of fast winding.

## And All These Well-known RP-100 Features:

Separate stereo 1/4 track record and playback heads permitting off-the-tape monitor and true sound-on-sound recording; separate transistor stereo record and stereo playback amplifiers meeting true high fidelity standards; monaural recording on 4 tracks; digital turns counter; electrodynamic braking (no mechanical brakes to wear out or loosen); all-electric push-button transport control (separate solenoids actuate pinch-roller and tape lifters); unequalled electronic control facilities such as mixing mic and line controls, two recording level meters, sound-on-sound recording selected on panel, playback mode selector, etc. Modular plug-in construction.

**Wow and flutter:** under 0.15% RMS at 7 1/2 IPS; under 0.2% RMS at 3 3/4 IPS. **Timing Accuracy:** ± 0.15% (±3 seconds in 30 minutes). **Frequency Response:** ± 2db 30-15,000 cps at 7 1/2 IPS, 55db signal-to-noise ratio; ± 2db 30-10,000 cps at 3 3/4 IPS, 50db signal-to-noise ratio. **Line Inputs Sensitivity:** 100mv. **Mike Inputs Sensitivity:** 0.5mv.

**Semikit: Tape transport assembled and tested; electronics in kit form \$299.95**  
**Factory-assembled: Handwired throughout by skilled American craftsmen \$399.95**

An original, exclusive EICO product designed and manufactured in the U.S.A. (Patents Pending)

**Carrying Case \$29.95**  
**Rack Mount \$9.95**



**FM-AM Stereo Tuner ST96**  
 Kit \$89.95 Wired \$129.95  
 Includes Metal Cover and FET



**70-Watt Integrated Stereo Amplifier ST70**  
 Kit \$99.95 Wired \$149.95  
 Includes Metal Cover

**40-Watt Integrated Stereo Amplifier ST40**  
 Kit \$79.95 Wired \$129.95  
 Includes Metal Cover



**FM MULTIPLEX AUTODAPTOR MX99 (Patent Pending)**  
 Kit \$39.95 Wired \$64.95 Cover Optional \$2.95

An original EICO contribution to the art of FM-Multiplex reception

The MX-99 employs the EICO-originated method of zero phase-shift filterless detection of FM Stereo signals (patent pending) described in the January 1962 issue of AUDIO Magazine (reprints available). This method prevents loss of channel separation due to phase shift of the L-R sub-channel before detection and matrixing with the L+R channel signal. In addition, the oscillator synchronizing circuit is phase-locked at all amplitudes of incoming 19kc pilot carrier, as well as extremely sensitive for fringe-area reception. This circuit also operates a neon lamp-indicator, whenever pilot carrier is present, to indicate that a stereo program is in progress. The type of detection employed inherently prevents SCA background music interference or any significant amount of 38kc carrier from appearing in the output. However, very sharp L-C low pass filters are provided in the cathode-follower audio output circuit to reduce to practical extinction any 19kc pilot carrier, any slight amounts of 38kc sub-carrier or harmonics thereof, and any undesired detection products. This can prove very important when tape recording stereo broadcasts. The MX-99 is self-powered and is completely factory pre-aligned. A very high quality printed board is provided to assure laboratory performance from every kit. The MX-99 is designed for all EICO FM equipment (ST96, HFT90, HFT92) and component quality, wide-band FM equipment.

©1962 EICO Electronic Instrument Co. Inc.  
 3300 Northern Boulevard, L. I. C., I. N. Y.

EICO, 3300 N. Blvd., L.I.C. 1, N.Y. HR-7

- Send free 32-page catalog & dealer's name
- Send new 36-page Guidebook to HI-FI for which I enclose 25¢ for postage & handling.

Name \_\_\_\_\_

Address \_\_\_\_\_

City \_\_\_\_\_ Zone \_\_\_\_\_ State \_\_\_\_\_

Over 2 MILLION EICO instruments in use.  
 Most EICO Dealers offer budget terms.  
 Add 5% in West.

Listen to the EICO Hour, WABC-FM, N. Y. 95.5 MC. Mon.-Fri., 7:15-8 P.M. Export Dept., Roburn Agencies Inc., 431 Greenwich St., New York 13



# Thoughts on Contemporary Music and Recording

by Igor Stravinsky

**C**ON-TEMPO: "with the times." Con-tempo music is the most interesting music that has ever been written, and the present moment is the most exciting in music history. It always has been. Nearly all con-tempo music is bad, too, and so was it ever. The "lament of present days," as Byron called it, is as old as the first antiquarian.

Modern: *modernus, modo*: "just now." But, also, *modus*, "manner," whence "up-to-date" and "fashionable." A more complex word and evidently an urban one, though I shall have to look this up in the Latin and French poets. (Rimbaud: "*Il faut être absolument moderne.*")

And "new music"? But that misplaces the emphasis. What is most new in new music dies quickest, and that which makes it live is all that is oldest and most tried. To oppose the new and the old is a *reductio ad absurdum*, and sectarian "new music" is the blight of contemporaneity. Let us use con-tempo, then, not technically, in the sense that Schoenberg and Chaminade lived at the same time, but in my meaning: "with the times."

\* \* \*

To the performer, a recording is valuable chiefly as a mirror. He is able to reflect himself in it, to walk away from his subjective experience and look at it. A recording session is a shuttling back and forth from subjective to objective, and the performer is like a muralist stepping back to see his work in perspective. In my case the perspective of the object, the playback, dwindles to a mere point of identity when I begin to conduct, and the located object "myself conducting

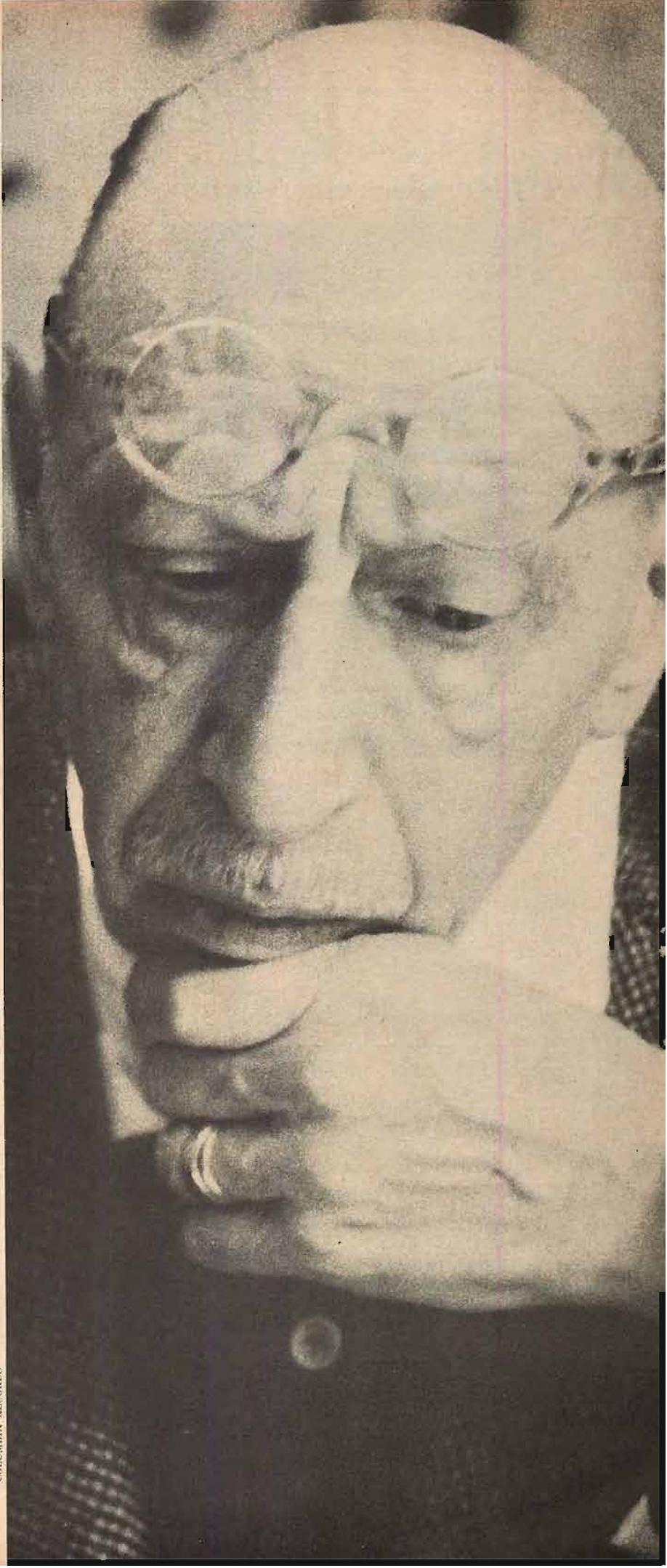



## IGOR STRAVINSKY THROUGH THE YEARS

BETTMANN ARCHIVE



the music" is replaced by, simply, "the music" (or "myself in the music," for I am always aware of my being in my music). This is the main item, I think, and not whether the recording extends the range of peripheral hearing or canalizes hearing selectively: a record is a lever to lift one outside of one's performance involvement altogether, or far enough out, at least, to bring about the illusion.

\* \* \*

Mirrors are also mnemonic devices. One sees what one was rather than what one is; the immediate has too many shadings. I look into my mirrors and am aware only of the subtraction; I listen to myself only to compare. The recognition of a time seam and its point of view is evident to me in other people's recordings of other composers, too, though my reaction to it is more passive. And I imagine that any performer who is still growing must be similarly disturbed (while an occasional Narcissus, hydrocephalic, will drown on the turntable of his own recorded performance).

\* \* \*

By definition contemporary music is unfamiliar, and, by deduction, it is more difficult than other types of music to record. (I do not say that it is more difficult



COLUMBIA RECORDS

*At left: Stravinsky in 1911, the year of Petrouchka, with the dancer Nijinsky. Above: in 1920, in Paris, where Stravinsky had taken up residence after the revolution in Russia.*

to perform; it is and it isn't, in different ways.) The fifty recordings of the Beethoven symphony are fifty different angles of distortion, but these distortions actually protect the scope of the work: the larger the variorum the greater the guarantee that Beethoven himself will remain intact. The recording of the contemporary, on the other hand, lacks comparison and therefore fixes the music at a single angle. Moreover, the greatest danger of this fixed angle is not obvious. It is that the truly contemporary must always exist on the precarious edge of the comprehensible—for most people. What is wrong with the Beethoven performance is evident and cannot damage the work, but what is wrong in the performance of the contemporary work is not at all evident, and the line between sense and nonsense in contemporary music may, and often does, depend upon its performance. The difference between a Kandinsky and a doodler, a Schoenberg and a lunatic was apparent to only a few imaginative and highly trained perceivers in 1912. (In Schoenberg's case we know that even such a close disciple as Alban Berg could not readily follow the gigantic leap of imagination in *Pierrot lunaire*.) I state as axiomatic, then, that performance of the unfamiliar is a greater responsibility and must seek higher standards than performance of the familiar. Every first recording is a risk.





Jean Cocteau, Pablo Picasso, Stravinsky, and Mme Picasso at Antibes in 1926.

COLUMBIA RECORDS



A case history, the recording of Anton Webern's numbered *opera*, a project that I helped to foster by giving quarters of hours from my own sessions, in which time the smaller instrumental pieces were recorded. (The larger ones were phonographed in a single session—that is, in about the same time as the most carefully barbered conductors are allowed to capture the full expressive essence of the trumpet solo in *Rienzi*.) The younger generation in every country of the world heard Webern's music for the first time from those records and I do not exaggerate when I say that their appearance, tardy as it was (they were made in 1954 but released in 1957) has been a determining event in contemporary music. But they are Webern seen from only one angle, and they bind him to it inflexibly, which is to say that like all newly born animals they are stiff, and like all best first readings they are more lucid than dramatic and more accurate than expressive. But these dangers and limitations are less important than the fact of the existence of the recordings (so far as I have the right to say, not being Webern), if only because a second reading, more dramatic and expressive and more and less of other things, is now possible.



The Webern records raise the question of value in repertory versus nonrepertory. I see no artistic reason to proliferate recordings of music that is widely performed live. I mean, of course, the concertos in B-flat Minor, the tone poems in E-flat Major, the symphonies in E Minor. A recording is, or should be, a performance, and I cannot suffer exactly the same set of performance limitations more than once—at least not with familiar music. I do suffer from them when the music is unfamiliar but less painfully because they do not distract me unduly from the learning process, the becoming familiar. The recording of nonrepertory, of what is not generally available live, should be, in my opinion, the *raison d'être* of the record industry. How many people have heard live performances of the two Webern cantatas in the United States? The answer—in full figures for per capita comparison—is 000,000,000. And the conclusion is obvious: recordings, rather than isolated and sporadic live performances, are the chief means of communication between the contemporary composer and his audience.



A footnote on nonrepertory with another meaning of that term: nonexistent. An advertisement for a record from the current catalog says something about "Stokowski's Bach." But no such Bach ever existed.



## IGOR STRAVINSKY THROUGH THE YEARS



COLUMBIA RECORDS

*Stravinsky in his Paris apartment during the middle 1930's.*

"Bach's Stokowski" would make far more sense historically. And I have just received another album with a blurb about "The great conductor" von K.'s "Mozart." But what does von K.'s conducting really do to Mozart? It opens his bier, unclasps his hands from his bosom, and folds them behind his head.



I have just received some programs of a concert series in Moscow dedicated to my later music. Every musician—composers, conductors, music educators—to whom I have shown them has made the same comment: "I wonder what the performances sounded like since no one there has heard the music." In other words, the printed page is no longer sufficient and should be supplemented by a recording as a guide to interpretation.



What are my attitudes to my own recorded performances? I have already said that I listen to them only professionally and critically and that I could not, as well as would not, do any of them the same way again. But even the poorest of them are at least valid readings that can guide other performers, and the best, like the new *Oedipus Rex* and the complete *Firebird*, are very good indeed. What are the poorest? Those pieces that



COLUMBIA RECORDS

*Modern Orpheus: Stravinsky "plays" a Citroen radiator grille.*

were too new to me, and for which I had not yet acquired a settled technique of performance.



What is most important about a recorded performance? An indefinable but instantly recognizable spirit. The spirit of the London recordings of my music has fallen arches, for instance, while the spirit of the Mercury recordings has been propped up in Adler elevator shoes. Next to the spirit are the two chief questions of the flesh: tempo and balance. I am considerably annoyed by the violin solo in my *Agon* recording. It sounds as though it is coming from the bedroom, while the accompaniment of trombones is in my lap. Many early stereo recordings committed mistakes of that sort, and whereas a monaural was a closet, an early stereo was three closets. We heard things we had never heard before, but we didn't always want to; let backgrounds be backgrounds, like bygones. But I am more irritated still by an insupportable tempo. If speeds of everything in the world and in ourselves are changing, musical tempi cannot remain the same. The metronomic markings one wrote forty years ago were contemporary forty years ago, but every performance is a different set of circumstances, and tempo must be effected by circumstance. I doubt that any of my own recorded tempi match my metronome markings.





CULVER PICTURES

Stravinsky in 1941, at fifty-nine years of age.

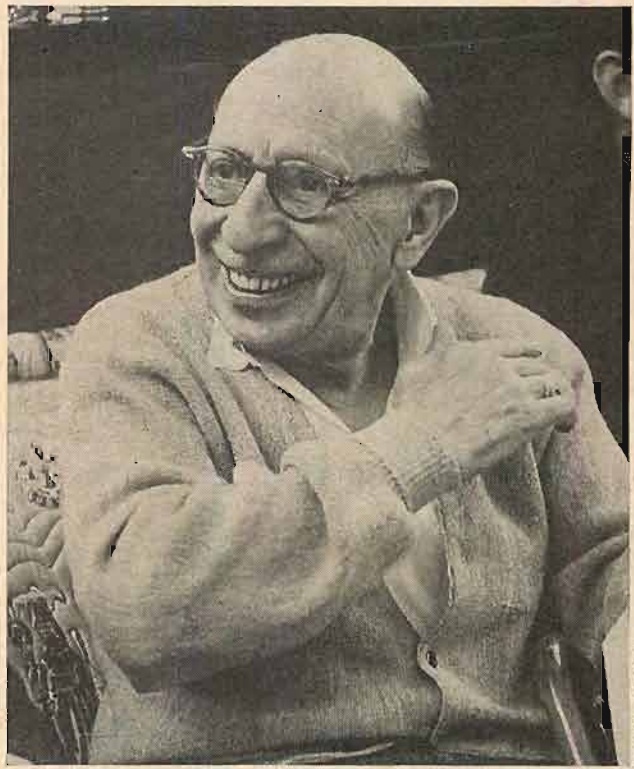

CBS TELEVISION

During the videotaping, in 1962, of a major new work, *The Flood*.



"Live music is at least a performance." This familiar statement implies that recordings are not performances. In fact, though, performers can be inspired even in the dreariest recording studio and the concentration there is at least as great as it is in a concert. With technically complex contemporary music, a true performance on records, though it should always be the goal, is difficult to achieve. It is, in fact, more likely to be a paste of excerpts from the best of several forays. I can make this clear only by a description of such a session.

It lasts three hours. The music has not been rehearsed and the first two hours are therefore consumed spot-rehearsing it. During this time microphones are adjusted, balance tests are made, positions of instruments are changed, and sometimes even the whole orchestra is reseat. The conductor's faculties are entirely concentrated on the problem of when to stop and correct—on deciding what a player or an orchestra is likely to correct the next time around on its own and what it will never understand without prompting and explanation. This is a matter of the conductor's experience but not entirely that, and some part of it will always be a gamble. When this perfunctory contact with the music is over and the actual recording has begun, the conductor's attention is turned from the music to the clock. From then on he becomes a ma-

chine for making decisions. Can this section be performed better if it is played once more? How much time remains and how much music has still to be recorded? The recording director will advise him to go on, of course, telling him the section may be repeated "if time is left at the end" (quotation from the standard A-&-R recording director's manual) but every recording session is a photo finish, and if one could return to something recorded earlier the sound levels would not match.

If the conductor is the surgeon in this three-hour operation, his anaesthetist is the A-&-R recording supervisor. This accomplice must be a virtuoso listener and score-reader, a child psychologist, and an accomplished liar ("Marvelous take, everybody"). He must know his artist to such an extent that he can keep him directed toward a performance the artist himself may have lost sight of.

He must hide his boredom, too, for most of his time is spent in recording the Liberaces of popular classical music, and the little contemporary music he does (in this case not contemporary but modern) are apt to be the gimmick pieces for vibraphones, *sprechstimme*, and *ponticello*—in other words, sound effects rather than music. Qualified recording supervisors are rare, and the opportunity to collaborate with them is rarer still. I have such a collaboration. And I hope to make many more records.



## INSTALLATION OF THE MONTH

# SOUND OUT OF SIGHT

*The control center fits compactly into an alcove that faces the loudspeaker installation across the room.*



BOB SERATINO

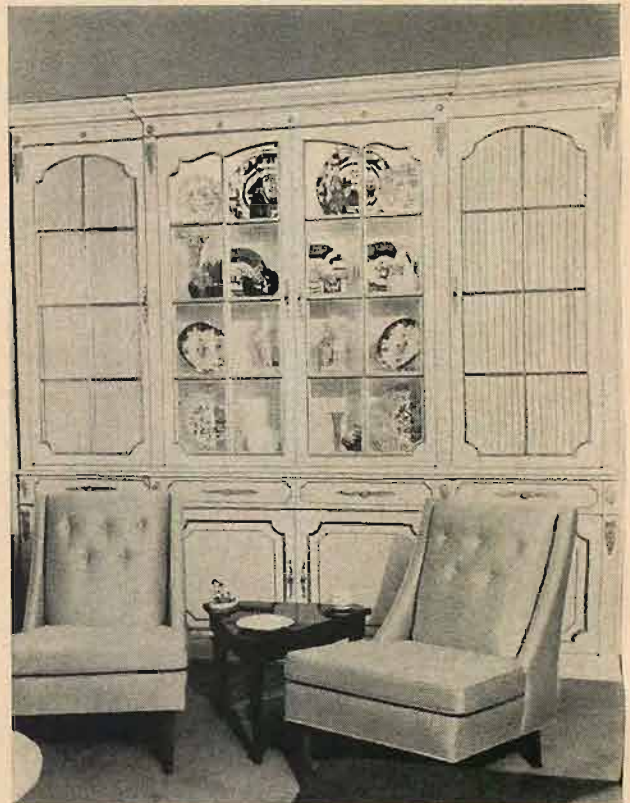

*Concealed behind the curtained doors of the credenza are two Tannoy speakers, each in a bass-reflex enclosure.*

RECONCILING the dictates of decor with the requirements of good sound can be a difficult proposition, especially when the logical place for the loudspeakers is pre-empted by a large credenza in French Directoire style. This was the situation faced by Mordecai Schwartz of Continental Sound when he was called upon to install a stereo system in the home of Mr. Sidney Freedman, a building contractor in Forest Hills, N.Y. The best solution, Mr. Schwartz decided, was to install the speakers in the credenza itself. Glass panes were removed from the two outer doors and replaced by sonically transparent curtains, and behind these were concealed two Tannoy 15-inch dual concentric speakers, each in a heavy plywood bass-reflex enclosure. To prevent vibration from rattling Mr. Freedman's treasured collection of porcelain, the speaker enclosures were placed on a thick layer of Tufflex, a commercial sound-absorbent material.

A small alcove at the opposite side of the room was converted into a compact control area that houses a Harman-Kardon Citation I and II preamplifier and amplifier, a Citation III-X stereo tuner, a Thorens TD-124 turntable with an Empire 98 tone arm and an Ortofon cartridge, a Garrard RC-88 changer with a Shure M7D cartridge, and a Berlant-Concertone Series 20-20 tape recorder. The electronic components are cooled through side vents by a small fan.



*A discussion of one of human physiology's most engrossing enigmas: how the cochlea converts variations in pressure into a sensation of sound.*

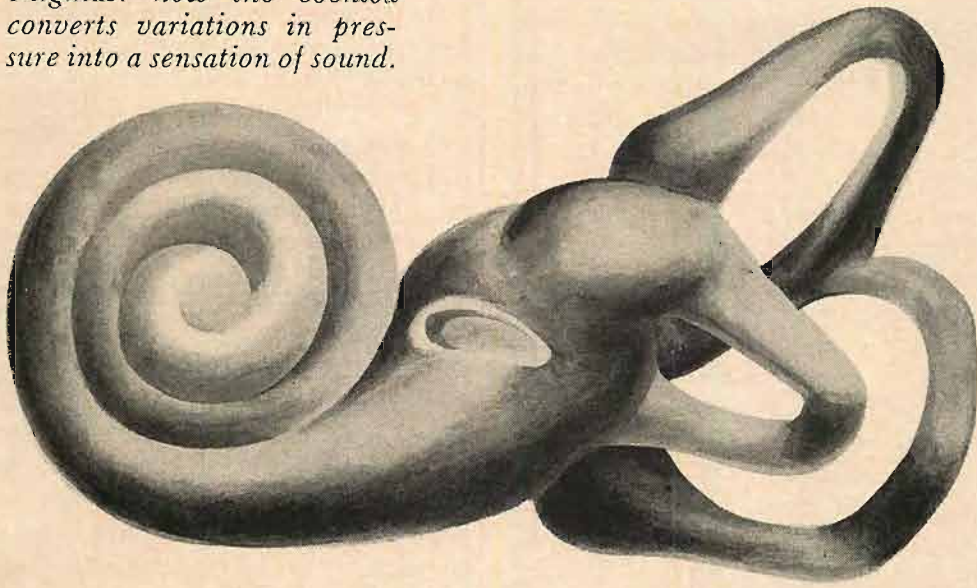

## NEW IDEAS ABOUT EARS

THE AVERAGE music listener, engrossed in a Debussy nocturne or a Beethoven symphony, may be deeply moved by what he hears, but he is rarely moved to wonder how his ears can convert air vibrations into perceptions of music. This is probably just as well, because the knowledge-seeker who sets out to discover the True Facts about how his ears work soon makes the rather frustrating discovery that much of what passes for sure knowledge about hearing is theory, and some of it is sheer speculation. For even though ears have always been in plentiful supply for scientific study, their most complicated part lies buried inaccessibly deep in the dense bone of the skull.

Early researchers who dissected cadavers had no trouble figuring out that vibrations aroused by sound waves striking the eardrum were transmitted by a linkage of tiny bones—the hammer, the anvil, and the stirrup—to a flexible window on the ear's innermost chamber, a fluid-filled spiral labyrinth called the cochlea, whose descriptive name was taken from the Greek word for snail. They could also see that the cochlea is connected to the brain by a large bundle of nerve filaments, and infer that somehow the cochlea passes on data that the brain interprets as sounds; but precisely how the cochlea operates to accomplish this marvel has remained a subject for debate and speculation. (*Continued overleaf*)

by J. GORDON HOLT



## NEW IDEAS ABOUT EARS

One theory suggested that, since nerves are known to carry tiny electrical impulses, the cochlea must simply act as a microphone, converting mechanical sound vibrations into electrical signals that the brain then identifies as sounds. This idea, though beautiful in its simplicity, had one serious flaw: everything we already knew about the physiology of hearing tended to refute it.

To begin with, nerves just do not function like wires. A wire will transmit any kind of electrical signal that is fed over it—sine waves, square waves, and all the various complex wave forms that make up natural sounds. A nerve, however, can transmit only one kind of signal: a series of identical impulses of very limited repetition rate. Each of the long, tandem-connected cells that comprise a nerve route is a tiny, self-charging battery that holds its charge rather precariously. A change in voltage at the first cell in the line discharges it, resulting in a single impulse of voltage change. This travels the length of the cell, upsets the next cell along the line, and discharges it. Thus, a single impulse is "relayed" from cell to cell along the entire length of the nerve fiber. But once an individual cell has fired it takes about 2/1,000 of a second to recharge before it can fire again, so no nerve can pass more than about five hundred impulses per second to the brain—a maximum rate that is inconsistent with the fact that human beings can hear up to 20,000 cycles per second.

But if the microphone analogy was too naïve to be taken very seriously, there was still the obvious fact that the brain was somehow getting information about high-frequency sounds, and experimenters set about discovering how. The result was the so-called place theory of pitch perception.

According to the place theory, tones of different frequencies stimulate nerve endings at different places along the cochlea's flexible membrane, and we distinguish pitch according to the particular place that is being stimulated. The place theory visualizes all of the cochlea's nerve endings as being connected by nerve fibers directly to specific areas of the brain's

auditory centers, so that when a certain area receives nerve impulses the brain "knows" which part of the cochlea these are coming from and perceives the appropriate pitch.

During the early 1930's, the acoustician Georg von Békésy confirmed at least part of the place theory by observing that in a carefully dissected-out cochlea sounds of different frequencies did indeed excite different areas of the nerve-lined basilar membrane, which divides the cochlea in half for almost its entire length. Within the deep-bass range, from 15-50 cycles, the entire membrane vibrated, stimulating all the nerve endings ranged along it. At slightly above 50 cycles, Békésy observed that the membrane vibrated maximally at a particular place near the gap (the helicotrema) at the apex of the cochlea. Raising the frequency, he then observed that this vibration point moved along the membrane toward the broad end of the cochlea. Meanwhile, other researchers had been "mapping" the surface of the brain's auditory centers, and had found that vibration of specific places on the basilar membrane caused response in specific locations of the brain. This seemed to prove the place theory—almost.

Unfortunately, there were still some unanswered questions. How could vibrations of a relatively long segment of the basilar membrane account for our ability to detect extremely small differences in pitch (one cycle in 1,000) throughout our hearing range? Békésy attributed this to a "sharpening" or "funneling" process whose operation was still unclear, but even this hypothesis left several puzzling questions.

**O**NE THING it failed to explain was how the hearing mechanism can experience subjective perception of a pitch when the appropriate place on the basilar membrane is not being stimulated at all. For example, if you start with a complex musical tone and then filter out the fundamental, leaving only the overtones, the basilar membrane at the place corresponding to the fundamental frequency will cease to vibrate, yet you continue to hear the fundamental as if it were still sounding. If you take a continuous high-pitched tone and turn it on and off gradually at a rate of, say,

*This schematic cross-section of the human ear shows how sound pressure from the eardrum is transmitted to the fluid in the cochlear cavity. At bass frequencies in the range of 15 to 50 cps, the entire nerve-bearing basilar membrane is deflected by the vibration.*

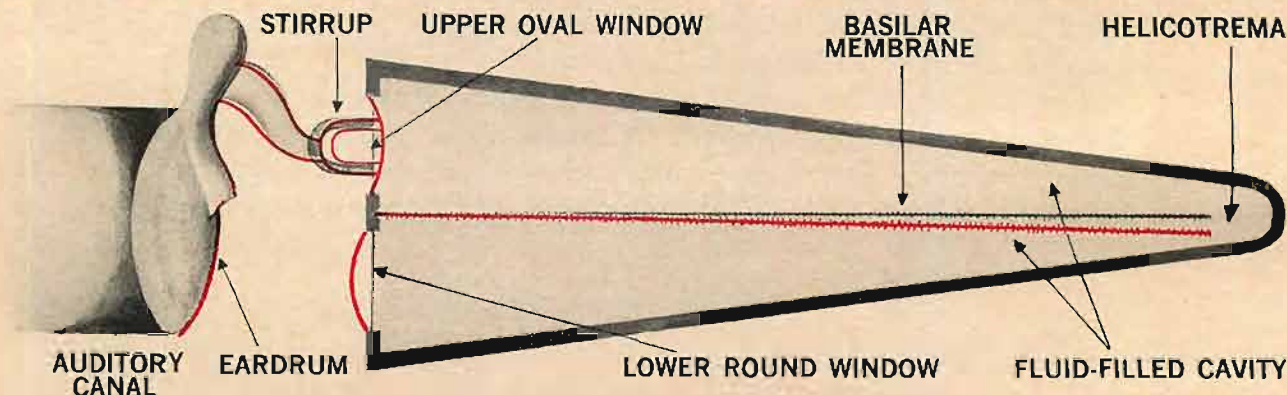



100 times a second, the 100-cycle place on the basilar membrane will show no movement, yet you will hear a distinct 100-cycle tone.

In phenomena such as these, the periodic discontinuities in the sound create an illusory pitch of the frequency at which they occur. So evidently the brain derives pitch information from the repetition rate of complex sounds rather than from their placement on the basilar membrane. And, if this is indeed the case, the brain must be counting the individual bursts, or volleys, of nerve impulses sent out by each movement of the membrane. This idea is the basis for the volley theory of pitch perception.

**B**ÉKÉSY had reported that in response to sounds of very low frequencies the basilar membrane vibrated along its entire length. This would discharge all its nerve endings with each movement of the membrane, so these volleys of impulses would occur in perfect synchronism with the cycles of the tone. This was how the place theorists accounted for pitch perception below 50 cycles, where placement on the basilar membrane ceased to exist. But since sounds that were higher in frequency than 50 cycles produced definitely localized action on the membrane, the place theorists held that place alone was responsible for perception of all these higher-pitched tones.

The volley theorists recognized the fact that above the deep-bass range different frequencies affected different places on the basilar membrane, but they denied that this had anything to do with pitch perception. They insisted, rather, that the timing between volleys of nerve impulses—each volley corresponding to a single cycle of sound—was solely responsible for transmitting pitch information to the brain.

But, said the place theorists, since no nerve can transmit more than about five hundred impulses per second, how can impulses keep synchronized with the cycles of a high-pitched tone? No trouble at all, replied the volley theorists: different nerves take turns firing on successive cycles, like the spark plugs in an automobile engine. Anatomists had established that each part of the basilar membrane is served by hundreds of nerve fibers; why attribute this to nothing more than gross wastefulness? Obviously such proliferation had a purpose, and that was to enable the alternate nerves to fill in during each other's recharging periods and so accomplish reciprocally what they could not accomplish singly.

Thus the volley theory seemed to provide a logically sufficient explanation of the phenomena of hearing—until neurologists got around to measuring the frequency response of the multi-fibred nerve that connects the cochlea to the brain. They did confirm that each nerve fiber gave off impulses in synchronism

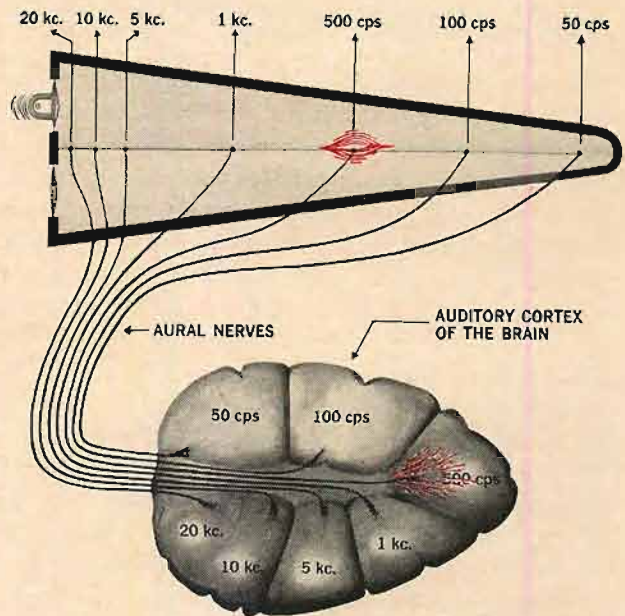

According to the place theory, different frequencies stimulate different parts of the basilar membrane and corresponding areas of the auditory cortex. The sketch shows this for a 500-cps note.

with the cycles of sounds up to around 500 cycles, and they detected, from groups of nerves, synchronized volleys in response to frequencies well beyond each nerve's 500-cycle limit. But they also found that the volleys start to lose synchronism with stimuli above 3,000 cycles and to deteriorate into purely random nerve impulses by about 6,000 cycles. So apparently the volley theory was not the whole explanation either.

**W**ELL, THEN, how does the human hearing mechanism perceive pitch—through response to volleying or through response to “place”? The consensus now seems to be that the brain uses both kinds of data, responding to volleying alone for frequencies from 15 to 50 cycles, to a combination of volleying and place for tones from 50 to 3,000 cycles, and to place alone for sustained tones of higher frequency.

In the range within which both placement and volleying occur, the brain appears to have some way of selecting which of the two best conveys the desired information. Thus the pitch of a sustained tone that produces both placement and volleying responses might be perceived in either way. But in dealing with a sound whose vibrations are not regularly spaced in time, and so elicit no definitely localized placement response from the basilar membrane, the brain has to rely for pitch data entirely on the individual volleys of nerve impulses created by each succeeding vibration.

Keeping track of such rapid volleys would seem to be an almost impossible task, but the brain appears to be well able to make instantaneous computations of the sort. As a matter of fact, the sense of spacious-



## NEW IDEAS ABOUT EARS

ness that we associate with stereophonic, or concert-hall, hearing is a result of the brain's remarkable facility in dealing with very minute differences, both in timing and in intensity. Because of the spacing between our ears, and the shape of the ear openings, sounds other than those coming from directly ahead or directly behind us reach the closer ear a fraction of a second before they reach the other, and with somewhat higher intensity. The hearing nerves maintain the delay between the impulses and convey information about the differing loudness by transmitting more nerve impulses in response to the louder sound. The brain interprets these differences as directionality. It locates an individual sound as coming from the side that sends the brain the first and the most numerous impulses, and the total perception of space in a reverberant auditorium is the brain's reaction to thousands of these time and intensity (quantity) differences between the echoes arriving at our ears from walls, floor, and ceiling.

We seem to have no conscious control over our ability to perceive the spatial characteristics of sound,

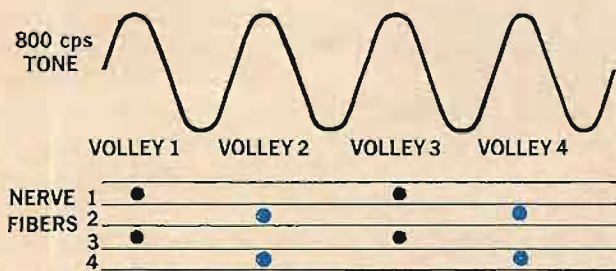

*The volley theory of pitch perception explains how the 500-cps frequency limit of a single nerve fiber can be exceeded by using alternate nerve fibers in sequence. Here, two sets of nerve fibers are able to convey pitch information about a 800-cps tone.*

but there is evidence that the brain does exercise constant involuntary control over much of our hearing system. Since ears respond to air vibrations, it might be expected that they would pick up all vibrations within audible range. The fact is, though, that our hearing often tends to be quite selective. As long as the attention is directed at something else, like the words in a book, awareness of such familiar, unimportant sounds as ticking clocks and humming refrigerators is diminished, if not completely blocked.

This process of selective inhibition, like that of spatial perception, seems to be largely resistant to conscious control; we cannot simply will certain sounds to be unheard. Indeed, the more we try to ignore a sound, the more acutely we hear it. The inhibition occurs only by default, so to speak, when the atten-

tion is diverted. On the other hand, the fact that we can in certain circumstances exercise some positive control over what we hear is illustrated by the familiar "cocktail-party effect," whereby we are able to single out one voice from a general babble of conversation merely by concentrating on that voice. However, this focusing ability is more than just selective inhibition at work; otherwise we could do it equally well when listening with one ear—which we can't. It appears, rather, to be a function of yet another intricate time-comparison system, this one involving both channels of our hearing mechanism.

**M**OST of the nerve routes from each cochlea end up in the aural center on the opposite side of the brain. But in addition to these diagonal connections there are many that run to the same side of the brain, and many that run laterally between the two hearing-nerve routes, connecting them at several points along their length. Obviously, if all these cross-connections were to function at once they would simply do away with the advantages of two-eared hearing. But most of the cross-connections seem to be kept closed off most of the time, presumably by inhibiting controls sent from the brain to their junction points through the system of returning nerves.

The exact operation of this maze of cross-wiring is still a puzzle to neurologists, but some of them are inclined to believe that it acts as a delaying system, whereby either hearing channel can be lengthened to some degree—by rerouting nerve impulses through a more devious path—to change the time relationships between the information reaching the brain from each ear. This mechanism might explain how our aural focusing faculty works, since, by delaying the signals coming from the ear that receives them first, it could bring them into synchronism with the corresponding signals transmitted by the other ear so as to provide coincident patterns of signals from the sound that has drawn our attention. Other sounds, with different time delays, would remain unsynchronized and hence unfocused.

This last refinement, however, is pure speculation, based on little more than intuition and our growing knowledge of electronic circuits. When researchers do find out for certain, the knowledge probably will not enhance our enjoyment of Beethoven, but it may at least help to explain it.

---

*J. Gordon Holt uses his own ears to good advantage as a freelance recording engineer. The more recent of his many articles in this magazine were "How to Choose a Microphone" (June, 1962) and "Tips on Taping Stereo FM" (May, 1962).*



COLUMBIA RECORD CLUB  
now offers new members

# The Best of Two Musical Worlds

AS A NEW MEMBER YOU ARE INVITED TO TAKE

**ANY 6** of these \$3.98 to \$5.98 records **\$1.89** REGULAR or STEREO FOR ONLY RETAIL VALUE UP TO \$35.88

if you join the Club now and agree to purchase as few as 6 selections from the more than 400 to be made available during the coming 12 months

### GREAT JAZZ

<b>ANDRE PREVIN</b> A Touch of Elegance THE MUSIC OF DUKE ELLINGTON COLUMBIA 50	<b>ANDRE PREVIN AND HIS TRIO</b> Give My Regards To Broadway COLUMBIA 51	<b>TIME OUT</b> THE DAVE BRUBECK QUARTET COLUMBIA 52	<b>Time Further Out</b> The Dave Brubeck Quartet COLUMBIA 53
<b>MILES DAVIS</b> Sketches of Spain COLUMBIA 56	<b>THE DUKES OF DIXIELAND</b> BREAKIN' IT UP ON BROADWAY COLUMBIA 81	<b>THE MODERN JAZZ QUARTET</b> Patterns COLUMBIA 95	<b>AHMAD JAMAL</b> HAPPY MOODS ARGO 96
<b>Quincy Jones</b> and his Orchestra at NEWPORT '61 Mercury 131	<b>GERRY MULLIGAN QUARTET</b> what is there to say? COLUMBIA 133	<b>WHO'S WHO IN THE SWINGING SIXTIES</b> THE MANY SOUNDS OF JAZZ TODAY * DAVE BRUBECK * LOUIS ARMSTRONG * MILES DAVIS * LIONEL HAMPTON * DUKE ELLINGTON and * COLLECTORS! BIRDY BIRD COLUMBIA 229	<b>MIDNIGHT IN MOSCOW</b> Kenny Ball KAPP 232
<b>MILES DAVIS</b> KIND OF BLUE COLUMBIA 290	<b>THE HOTTEST NEW GROUP IN JAZZ</b> LAMBERT, HENDRICKS & ROSS! COLUMBIA 291	<b>ELLINGTON INDIGOS</b> COLUMBIA 292	<b>CHARLES MINGUS</b> and his Jazz Groups MINGUS DYNASTY COLUMBIA 293
<b>CANNONBALL ADDERLEY</b> QUINTET - in CHICAGO Mercury 284	<b>BILLIE HOLIDAY</b> The Golden Years COLUMBIA 285-286-287 (Counts as Three Selections) (Monaural only)		

### GREAT CLASSICAL

<b>HANDEL: MESSIAH</b> LEONARD BERNSTEIN N. Y. PHILHARMONIC COLUMBIA 171-172 (Counts as Two Selections)	<b>CLAIR de LUNE</b> A Debussy Piano Recital by PHILIPPE ENTREMONT COLUMBIA 174	<b>Rhapsody in Blue</b> An American in Paris Leonard Bernstein plays Geisthaus COLUMBIA 176
<b>FINLANDIA</b> PHILADELPHIA ORCHESTRA - MORMON TABERNACLE CHOIR plus - Valde Triste - Glorious Flaggery - Peer Gynt Suite No. 1. COLUMBIA 177	<b>BETHOVEN</b> Piano Concerto No. 5 "Empireur" LEONARD BERNSTEIN COLUMBIA 183	<b>BETHOVEN</b> Violin Concerto ISAAC STERN New York Philharmonic, Leonard Bernstein, Cond. COLUMBIA 184
<b>CHOPIN:</b> The 14 Waltzes Brallovesky COLUMBIA 187	<b>RAVEL:</b> Bolero • La Valse Rapsodie Espagnole LEONARD BERNSTEIN N. Y. PHILHARMONIC COLUMBIA 191	<b>STRAVINSKY</b> conducts The "FIREBIRD" COMPLETE BALLET COLUMBIA 193
<b>FLAMENCO PURO</b> SABICAS COLUMBIA 198	<b>MUSIC BY EDGAR VARESE</b> Robert Craft conducting Woodwinds, Strings and Percussion COLUMBIA 201	<b>VIVALDI</b> FOUR CONCERTOS LEONARD BERNSTEIN conducting the NEW YORK PHILHARMONIC with soloists COLUMBIA 220
<b>Mozart Concertos</b> Nos. 22 and 23 ROBERT CASADESUS GEORGE SZELL Columbia Symphony COLUMBIA 206	<b>MAHLER</b> Symphony No. 4 BERNSTEIN New York Philharmonic COLUMBIA 218	<b>SVIATOSLAV RICHTER</b> at CARNEGIE HALL 5 Beethoven Sonatas COLUMBIA 202-203 (Counts as Two Selections) (Monaural only)
<b>ORFF: CIRIMBA BURANA</b> THE PHILADELPHIA ORCHESTRA soloists and chorus ORLANDO conducting COLUMBIA 342		

YES... HERE'S A WONDERFUL OPPORTUNITY to choose from classical masterworks performed by world-renowned artists - and jazz gems played by world-famous stars! By joining now, you may have ANY SIX of the 40 outstanding records shown on this page - up to a \$35.88 retail value - for only \$1.89. What's more, you'll also receive a remarkable hi-fi/stereo test record - absolutely FREE!

TO RECEIVE YOUR 6 RECORDS FOR ONLY \$1.89 - simply fill in and mail the coupon. Be sure to indicate whether you want your six records (and all future selections) in regular high-fidelity or stereo. Also indicate which Club Division best suits your musical taste: Classical; Listening and Dancing; Broadway, Movies, Television and Musical Comedies; Jazz.

HOW THE CLUB OPERATES: Each month the Club's staff of music experts selects outstanding records from every field of music. These selections are fully described in the Club's entertaining and informative music Magazine, which you receive free each month.

You may accept the monthly selection for your Division... or take any of the wide variety of other records offered in the Magazine, from all Divisions... or take no record in any particular month. Your only membership obligation is to purchase six records from the more than 400 to

be offered in the coming 12 months. Thereafter, you have no further obligation to buy any additional records... and you may discontinue membership at any time.

**FREE BONUS RECORDS GIVEN REGULARLY.** If you wish to continue as a member after purchasing six records, you will receive - FREE - a bonus record of your choice for every two additional selections you buy.

The records you want are mailed and billed to you at the list price of \$3.98 (Classical \$4.98; occasional Original Cast recordings somewhat higher), plus a small mailing and handling charge. Stereo records are \$1.00 more.

**MAIL THE COUPON TODAY** to receive your 6 records - plus a free hi-fi/stereo test record - for only \$1.89.

NOTE: Stereo records must be played only on a stereo record player.

**FREE** if you join now  
**TEST RECORD**  
FOR HI-FI AND STEREO MACHINES

This remarkable 7" record permits you to check the performance of your phonograph regardless of the type you own.



COLUMBIA RECORD CLUB, Dept. 220-5  
Terre Haute, Indiana

I accept your special offer and have written in the boxes below the numbers of the six records I wish to receive for \$1.89, plus small mailing and handling charge. I will also receive a hi-fi stereo test record - FREE.

Enroll me in the Club Division indicated below, with the understanding that I may select records from any Division. I agree to purchase six selections from the more than 400 to be offered during the coming 12 months, at the list price plus small mailing and handling charge. Thereafter, if I decide to continue my membership, I am to receive a 12" bonus record of my choice FREE for every two additional selections I accept.

Name: \_\_\_\_\_  
(Please Print)

Address: \_\_\_\_\_

City: \_\_\_\_\_ ZONE: \_\_\_\_\_ State: \_\_\_\_\_

BE SURE TO COMPLETE ALL 3 ITEMS BELOW

**1 SEND ME THESE SIX RECORDS**  
(fill in numbers below)

--	--	--	--	--	--

**2 SEND MY SIX RECORDS AND ALL FUTURE SELECTIONS IN** (check one box)

REGULAR HIGH-FIDELITY  STEREO

**3 ENROLL ME IN THE FOLLOWING DIVISION**  
(check one box)

Classical  Listening & Dancing  Jazz  
 Broadway, Movies, Television & Musical Comedies

APO, FPO addresses: write for special offer  
CANADA: prices slightly higher; 1111 Leslie St., Don Mills Ont.  
232 **SA-KE (REG)** **SA-SE (STER)**

© "Columbia," "Epic," "Mercury" Reg. © Columbia Records Distribution Corp., 1962



# NEW FROM SCOTT

## FINEST FM MULTIPLEX TUNER IN THE WORLD

### WITH AMAZING ELECTRONIC BRAIN

### THAT ACTUALLY THINKS FOR YOU!

This Wide-Band FM multiplex tuner is designed for the most critical stereo listener and for the most exacting applications imaginable. Its many features and stringent standards of performance make it the prudent choice for broadcast station monitoring. The famed advanced engineering group at H.H. Scott believes the sophisticated circuitry of the 4310 to represent the highest possible achievement in tuner engineering at this state of the art. This circuitry results in IHFM sensitivity of 1.9 microvolts. Scott's revolutionary Time-Switching multiplex section gives you practically noise-free reception of even weakest stereo signals, with separation of 30 db or better . . . truly an outstanding design achievement.

This superb tuner incorporates an amazing new "electronic brain" which is invaluable for serious tape recordists and discriminating listeners. As you tune across the FM dial, the 4310 AUTOMATICALLY switches to multiplex when a stereo broadcast is reached. If serious interference occurs, however, the tuner will switch back instantly and automatically to the monophonic FM mode, which is less susceptible to background noise. You completely disable this feature if you so desire, or you can set it so that switching occurs at that level of interference which you consider objectionable. Using this automatic feature, you hear practically flawless reception, with the tuner instantly picking the optimum mode for existing signal conditions.

This feature is essential for the tape recordist who wishes his recordings of prized material to be undisturbed by sudden interference, as often happens on very weak signals. The exceptional design and advanced features of the new H. H. Scott 4310 have already established new standards of achievement in the FM Field.

**IMPORTANT TECHNICAL INFORMATION:** IHFM sensitivity 1.9  $\mu$ v; Capture ratio 2.2 db; Signal to noise ratio 60 db; Harmonic distortion 0.5%; Frequency response 30-15,000 cps  $\pm$  1db; Selectivity 50 db; 4 FM IF stages; Cascade RF stage; Size in accessory case 15½ W x 5¼ H x 13¼ D. Rack mounted model available for broadcast station use.

Write today for technical details on these new tuners:



H. H. Scott, Inc., 111 Powdermill Rd., Maynard, Mass. Dept. 65



**Separate VU meter for each channel.** You can actually measure stereo separation between channels with these accurate meters enabling you to tune and orient your antenna for maximum stereo separation. Separate controls allow adjustment for broadcasts having unequal channel levels. Precision step-type master attenuator.

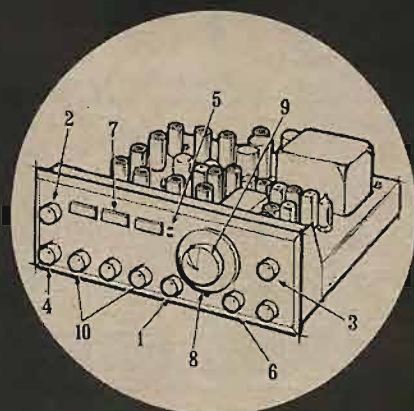

**Professional front panel controls:** 1. Stereo Threshold. 2. Multiple Diversity. 3. Precision Step-Type Level. 4. Stereo Selector. 5. Automatic Stereo Indicator. 6. Interstation Noise Suppressor. 7. Precision Signal Strength and Tuning Meter. 8. Logging Scale. 9. Main Tuning Dial. 10. Separate Level Controls for each channel.

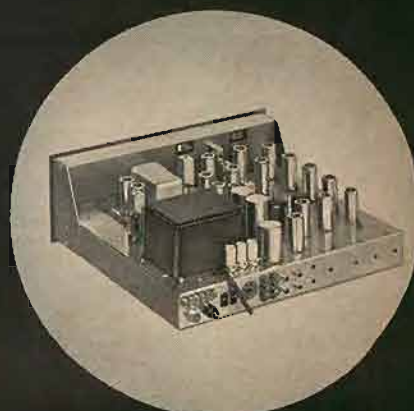

**Unique circuit features:** Diversity facilities for monitor and rebroadcast installations; Special tape recording filters; Automatic Stereo Threshold; Heavily silver-plated cascade front end; Provision for 72 ohm or 300 ohm balanced or unbalanced antenna inputs; 600 ohm output available. Automatic switching from monophonic to multiplex.





4310 Wide-Band FM Multiplex Broadcast Monitor Tuner

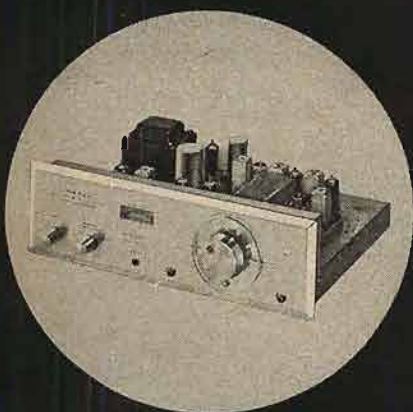

**New 350 FM Multiplex Tuner**  
 — Incorporates the latest advances in multiplex circuitry. Sensitivity  $2.5 \mu\text{V}$ . 3 FM IF stages. Precision tuning meter. Silver-plated front end. Sharp filtering circuits permit flawless stereo tape recording. Stereo separation can match exacting FCC transmission specifications. \$199.95, East of Rockies.

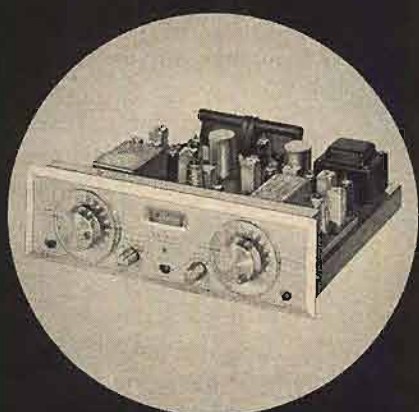

**New 333 AM/FM Multiplex Tuner**  
 — Combines the features and performance of the 350 FM Multiplex tuner with a famous Scott Wide-Range AM tuner all on one compact chassis. You can receive Monophonic AM or FM, AM/FM stereo or new FM Multiplex Stereo. FM sensitivity  $2.2 \mu\text{V}$ . Two AM bandwidth positions. Loopstick antenna for AM.

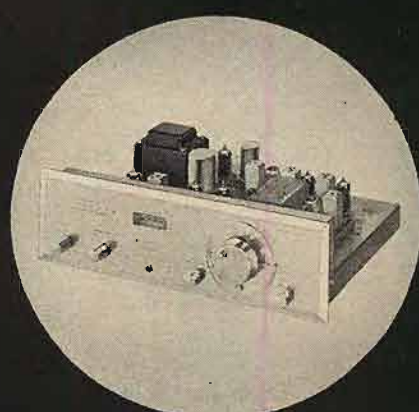

**LT-110 Wide-Band FM Multiplex Tuner Kit**  
 — Build your own fabulous Scott Tuner. The LT-110 includes the same superb multiplex circuitry as the 350. Pre-wired multiplex section and front end. Full color instruction book. You can build the LT-110 in less than 12 hours. Sensitivity  $2.2 \mu\text{V}$ . \$159.95, East of Rockies.



portable  
perfection  
for  
hi-fi fans



From Denmark comes this aristocrat of portables. Superb AM-FM-Shortwave performance with all the features you've ever wanted in a portable: 12 transistor power with push-pull output and a 5" x 7" speaker, flywheel tuning, full range independent tone controls, pushbutton selection, loudspeaker - earphone output and separate tuner output, plus plug-in connection for an auto antenna for over-the-road hi-fi.

Complete information is available on request. Write for the name of your nearest dealer.



By appointment  
to the Royal Danish Court

**DYNACO**

DYNACO, INC.  
3912 Powelton Ave., Phila. 4, Pa.

CIRCLE NO. 15 ON READER SERVICE CARD

## HiFi Soundings



by DAVID HALL

### THE INTERNATIONAL LOOK

A FEW MONTHS ago I had the pleasure of a visit to Rome to attend the inauguration of the huge new RCA Italiana recording studios. RCA's Rome plant is unusually interesting from the technological viewpoint, for it offers complete facilities for the making of records from studio session to final manufacture and packing. Even more interesting, however, is the way in which the new plant symbolizes today's increasingly broad international outlook on the part of the large record companies.

Of course, international arrangements in the record business are nothing new. Back in the 1930's the major world-wide record combine was Electric & Musical Industries, Ltd. of England (makers of His Master's Voice, Columbia, and Parlophone records in England), and serious disc collectors gained a surprising amount of knowledge about music-making in other countries thanks to the recorded performances made available from EMI through both RCA Victor and Columbia. For example, it was through the medium of recording, rather than through concert performances, that the conducting artistry of the late Sir Thomas Beecham became known to large numbers of music lovers in this country.

Today, not one but several international disc combines are fighting it out for a share of the American record buyer's dollar. Whereas in the past an overseas record firm would be content to make an exchange agreement with an American counterpart, today's giant international competitors are far more aggressive. In the old days EMI issued its recordings through RCA Victor and Columbia with no special identification. Then, in 1953, it established its own sales organization and special label for America—Angel, thus following the pattern set after the war by its biggest competitor, Teldec (a combination of English Decca and German Telefunken) in establishing London as a name to be reckoned with on these shores. Then in 1958, EMI went a step further by purchasing the American firm of Capitol and combining Angel with it.

The same pattern has obtained for the newest of the international giants, Philips of Holland, which made its entry on the American scene in late 1953 via the Epic label, created especially by American Columbia as part of an exchange agreement. But since the first of 1962, Philips has followed the EMI example of buying an American company, in this instance Mercury, which now issues records under both the Mercury and Philips imprints.

Deutsche Grammophon Gesellschaft, the German firm, also made its LP debut over here through a 1951 exchange arrangement with American Decca. But by the fall of 1959, DGG felt the need to establish its own identity in America, too, and so began issuing releases on the Deutsche Grammophon label, at first in Decca pressings, but subsequently in imported pressings. Since early this year, DGG has switched its American sales affiliation from Decca to MGM.

A special case among international combines is that of Artia-Parliament, an American firm that makes available both on its own





## *crunch*

Apples taste better when you're six years old. What's more they *sound* better. Those crunching noises reverberating through your head are exciting. You keep wondering if they can be heard on the "outside." Remember?

Naturally, you'll never hear an apple like that again. But if you've retained even a little sonic sensitivity, we can offer you an experience almost as pleasant.

Make your next recording on Audiotape.

You'll find that the wonderful quality of this tape provides more clarity, more range, eliminates noise and distortion

problems. And you'll find this quality is consistent from reel to reel and within every reel of Audiotape.

Whether you're taping a small apple-cruncher or a great symphony orchestra, there's an Audiotape exactly suited to your needs. From Audio Devices, for 25 years a leader in the manufacture of sound recording media—Audiodiscs\*, Audiofilm\* and ...

**audiotape**  
TRADE MARK

AUDIO DEVICES INC., 444 Madison Ave., N.Y. 22, N.Y.  
Offices in Los Angeles, Chicago, Washington, D.C.

CIRCLE NO. 6 ON READER SERVICE CARD

\*TRADE MARK



# ARE YOU BEING CHEATED?

We at GRADO are constantly asked "How does a consumer know which ads are truthful?" "How can the consumer be sure that what he buys is really good?" "What protection does the consumer have after he spends his money?" He couldn't be sure until now!

**100% CONSUMER PROTECTION.** Proof of GRADO integrity and superb product quality is what we offer you with absolutely no risk on our part!!

## GRADO SENATOR CARTRIDGE A Genuine Moving Coil Stereo Cartridge \$24.95

**CERTIFIED SPECIFICATIONS.** After carefully controlled Laboratory tests the New York Testing Laboratories certifies the following specifications to be completely accurate. (Note: These specifications will be recertified at various intervals to assure you, the consumer, of consistent quality).

### SPECIFICATIONS — CERTIFIED (New York Testing Laboratories)



**FREQUENCY  
RESPONSE:**  
20CPS-1KC—  
±1DB  
1KC-10KC—  
±1.5DB  
10KC-22KC—  
±2DB

**APPLICATION:**  
Tone Arm or  
Record Changer  
Excellent for  
Monaural Records

**CHANNEL  
SEPARATION:**  
Vertical—Lateral  
30DB-1KC  
18DB-15KC  
45°-45° } 1KC  
30DB } 15KC  
14DB }  
Output—  
8MV @ 10CMV  
Tracking Force—  
3 grams  
Diamond Stylus

**ONE YEAR UNCONDITIONAL GUARANTEE** (From date of purchase). If the cartridge becomes defective for any reason (including children) you will receive a brand new cartridge FREE!!

**5 YEAR DIAMOND STYLUS GUARANTEE.** If the diamond wears from playing within 5 years of the purchase (even in a record changer) GRADO will replace it FREE!!

**ADDITIONAL PROTECTION.** You may return the cartridge to your dealer for a full refund if you are not completely satisfied after ten days of close listening in your own home.

### THE EXPERTS SAY:

"Provided a tape like stereo effect with no instrument wander."  
Lorry Zide . . . American Record Guide

"Superb sound at any price."  
Chester Santon . . . Adventures in Sound, WQXR

If the cartridge becomes defective after the warranty period expires, for a flat fee of \$15.00, you will receive a brand new cartridge.

**ONLY GRADO CAN BE PURCHASED WITH COMPLETE SECURITY!!**

The above guarantee also cover:

Laboratory Stereo Cartridge \$49.50 • Classic Stereo Cartridge \$37.50

For Ultimate Results Use The **TOP RATED** Laboratory Series Tone Arm \$39.50

ASK YOUR DEALER ABOUT THE **GRADO DUSTAT \$6.95**  
**VELVET TOUCH RECORD CLEANER • NO MESSY FLUIDS**

FOR FURTHER  
INFORMATION WRITE: **GRADO LABORATORIES, INC.**  
4614 Seventh Ave., Brooklyn 20, N. Y. • Export—Simonfrice, 25 Warren St., N.Y.C.

domestic pressings and by direct import (on the MK, Supraphon, and Qualiton labels) the product of the government-owned record trusts of the Iron Curtain countries.

Just as the great European record companies are seeking to engage the awareness of the American buyers, so our own firms are battling for their share of the overseas market from Rio to Tokyo, from Iceland to New Zealand. In some instances, this is being done through cooperation with one of the international combines but with insistence that the identity of the American label be retained. A current result of this type of operation is the new CBS label, which Columbia has established abroad to promote its corporate image on a world-wide basis.

This jockeying of international record colossi has begun to make its effect felt in the American classical-record market, if only because the great promotional and sales power of the international combines puts a terrific squeeze on the smaller independent (and often more enterprising in terms of repertoire) labels. Those that specialize in such fields as folk songs, spoken word, or musi-



cal esoterica are least affected; but those whose catalogs impinge on areas covered by the giants find the competition getting ever more rough. To deal with this problem, some independents have entered into loose federations that allow them some of the benefits of big-company promotion and sales. The affiliation of Command and Westminster with ABC-Paramount is a prime example.

Whether the current trend toward domination of the disc market by the international giants, with the almost inevitable resultant restriction of independent companies to specialty areas, is good or bad from the classical-repertoire standpoint depends in large measure on whether the American buyer will be treated to an abundance of superior records or whether he is to be restricted to endless duplication of standard repertoire, indifferently performed, and with variable engineering. At this point, we can only hope for the best.



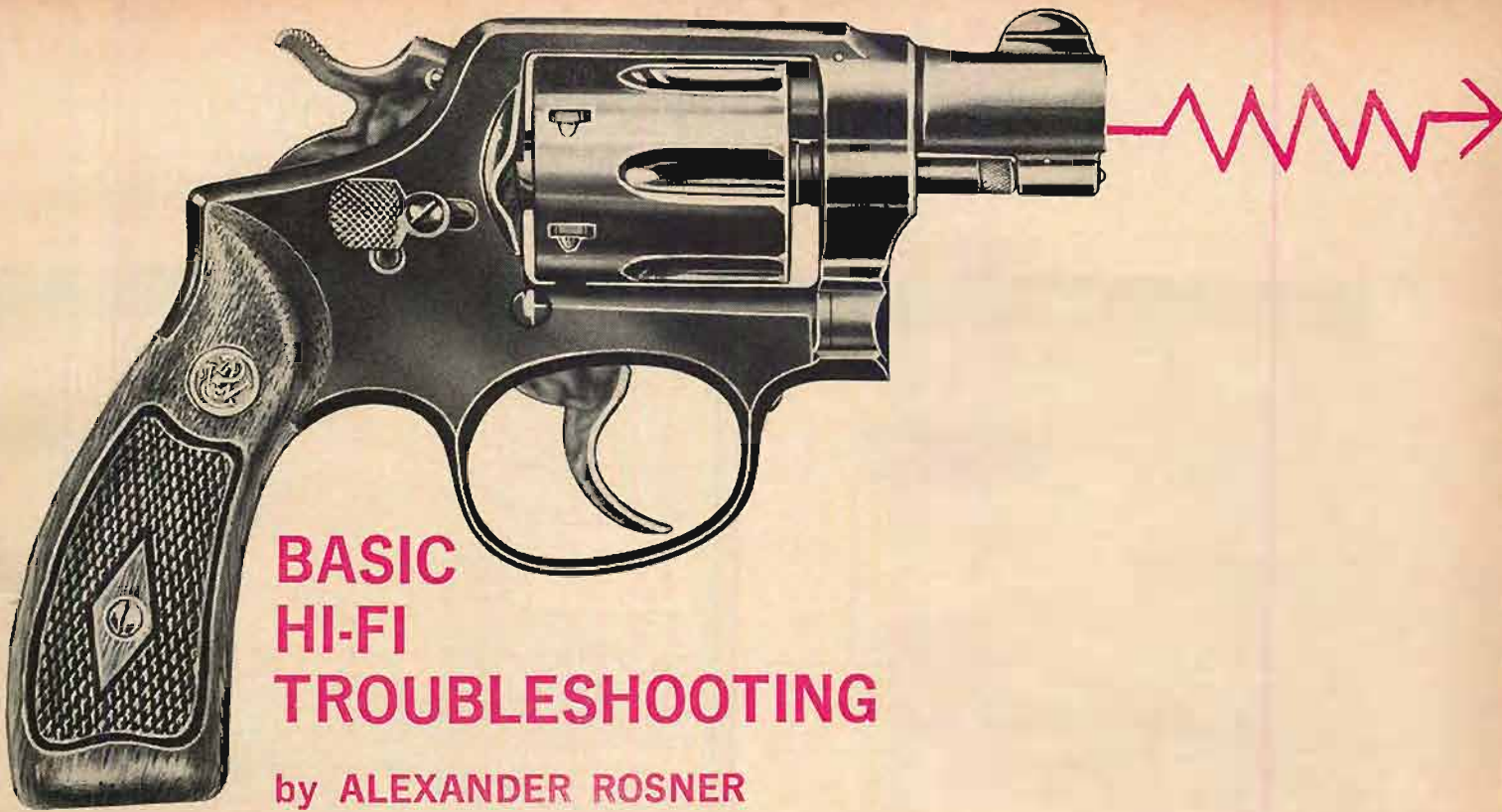

# BASIC HI-FI TROUBLESHOOTING

by ALEXANDER ROSNER

## A step-by-step approach for the beginning do-it-yourselfer

**I**F YOU have ever done any troubleshooting on hi-fi equipment you will know that it can be a great deal of fun. It is something like trying to solve a mystery. First you collect and evaluate the various clues; then you decide on the solution. A more tangible reward for investigating on your own before you call a serviceman is in the form of monetary savings. Even if you can't repair the equipment yourself, you can save the price of a service call by isolating the guilty component and taking it to a repair agency.

The trouble can often be found by checking the units and their interconnections, one at a time, beginning at the speaker end of the component chain. But this sequence is time-consuming, and by using the troubleshooting charts on pages 40 and 42, you can bypass most of it and work on only that area of the system that seems to be defective.

Some advice on the general technique of component-checking may be in order. When it appears that an electronic component—such as an amplifier—is defective, check the rectifier tube first, the preamplifier tube next, and then the other tubes. A noisy tube may not be detected by even the finest tube tester, so substitution is the only practical detection method. If you have a stereo amplifier, it's not necessary to keep many extra tubes on hand, as the tubes from the properly functioning channel can serve as substitutes.

Cable connections from one component to another are a common source of trouble. Cables may loosen, especially if your equipment is moved about from time to time. On occasion, they may corrode slightly, caus-

ing a slow deterioration of sound over a period of time. While cables are reasonably sturdy, they can become defective if they are subjected to undue tugging or twisting. One way to check a cable without the aid of test equipment is to use it to complete the circuit between a flashlight bulb and a battery or batteries. If the bulb lights, the cable is good.

In addition to discontinuities, strands of paired wires on cables, speakers, and cartridge leads that touch their neighbor and cause short circuits will effect a loss of sound. Frayed ends of cables and leads can be avoided by tinning the exposed wire with solder before attaching it to the proper terminal fitting or lug.

**S**UPPLEMENTING the troubleshooting charts is the chart on page 43, which shows common symptoms, the malfunctions that probably cause them, and suggested remedies. The items are grouped according to input source used, with general troubles first, followed by phono, then tuner, difficulties. Should your search for a defect require more than checking tubes, it would be wise to call a hi-fi serviceman, unless you have had experience at troubleshooting circuits. If you do not know of a good audio service shop, write the manufacturer, describing the malfunction in detail. You may be asked to ship your unit to the manufacturer's nearest authorized service agency. Be sure that you are sent an authorization before shipping your unit, and also be sure, when packing the unit for shipment, to enclose all pertinent correspondence and information about the malfunction.



# TROUBLESHOOTING

## DISTORTED OR NOISY SOUND

ck. control settings, and listen with alternate inputs

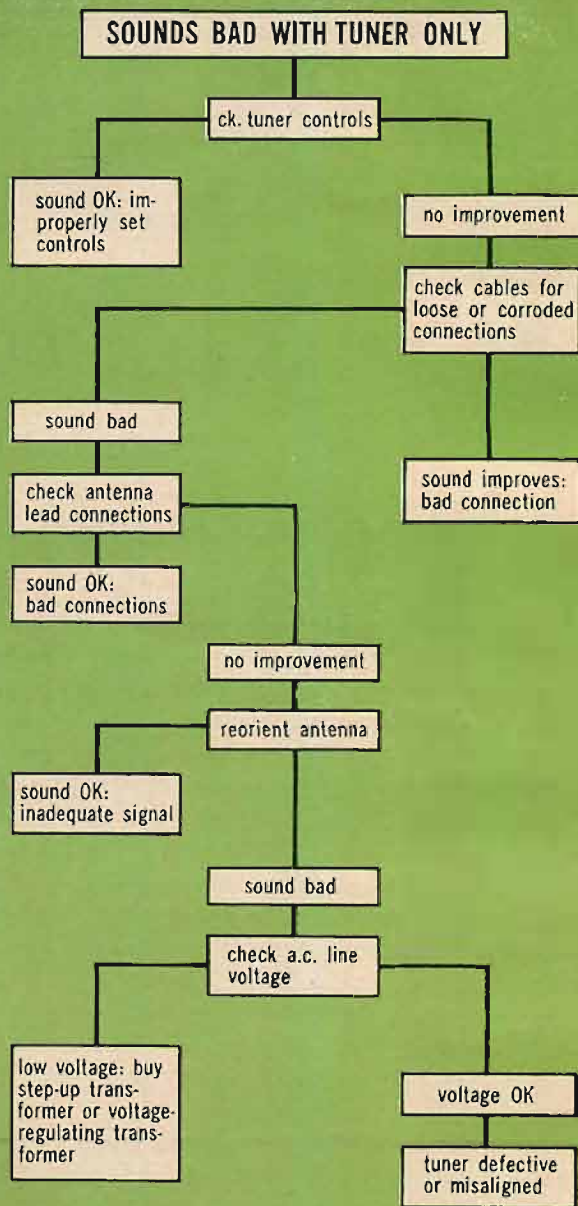
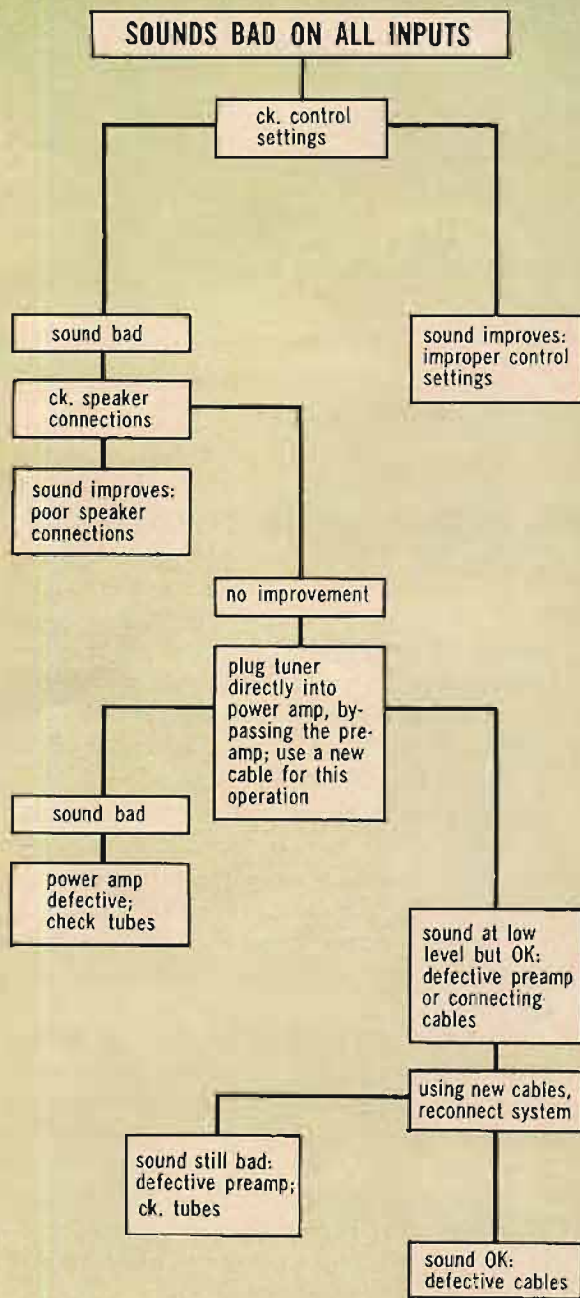



**SOUNDS BAD WITH PHONO ONLY**

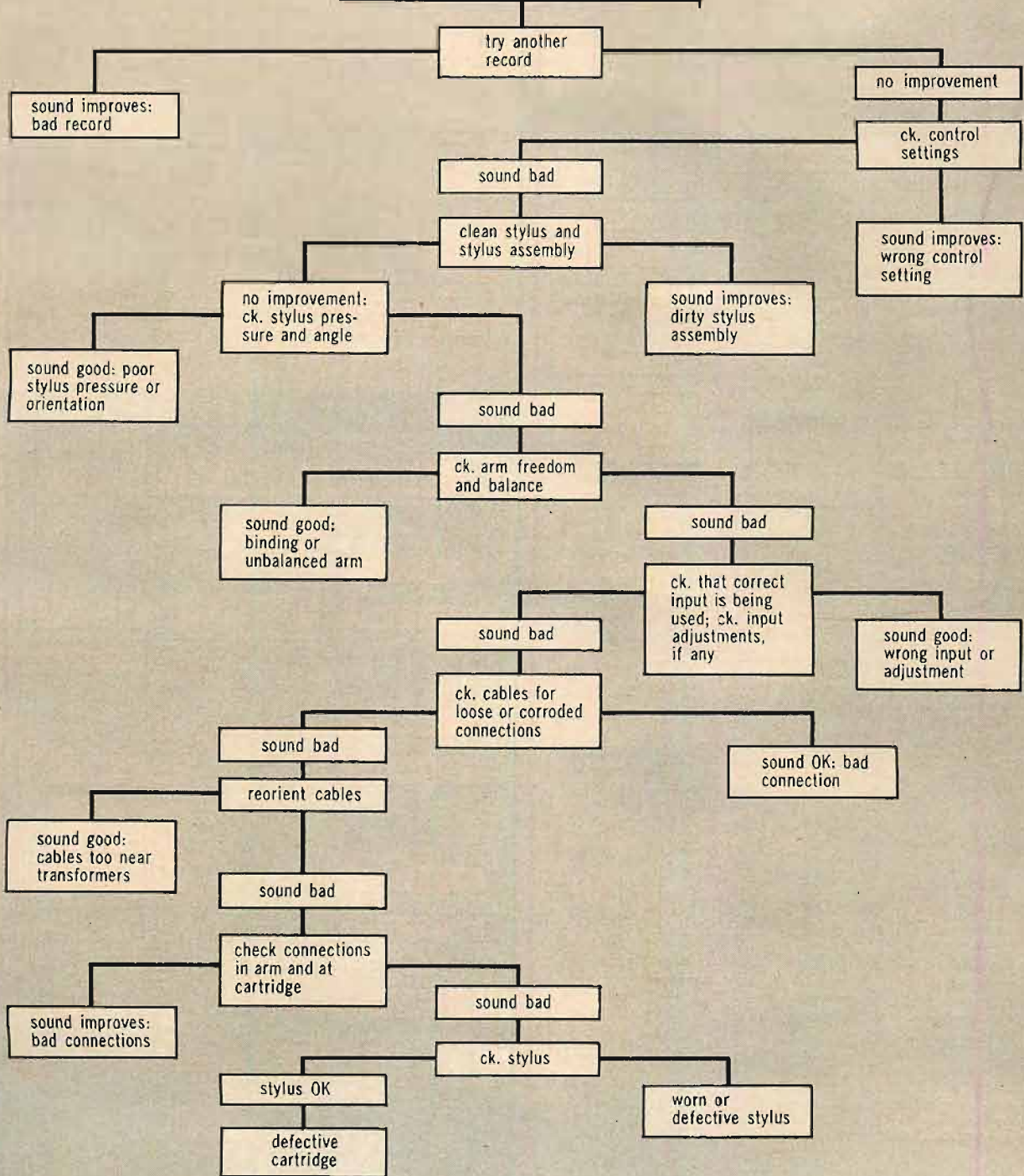



# TROUBLESHOOTING

## NO SOUND

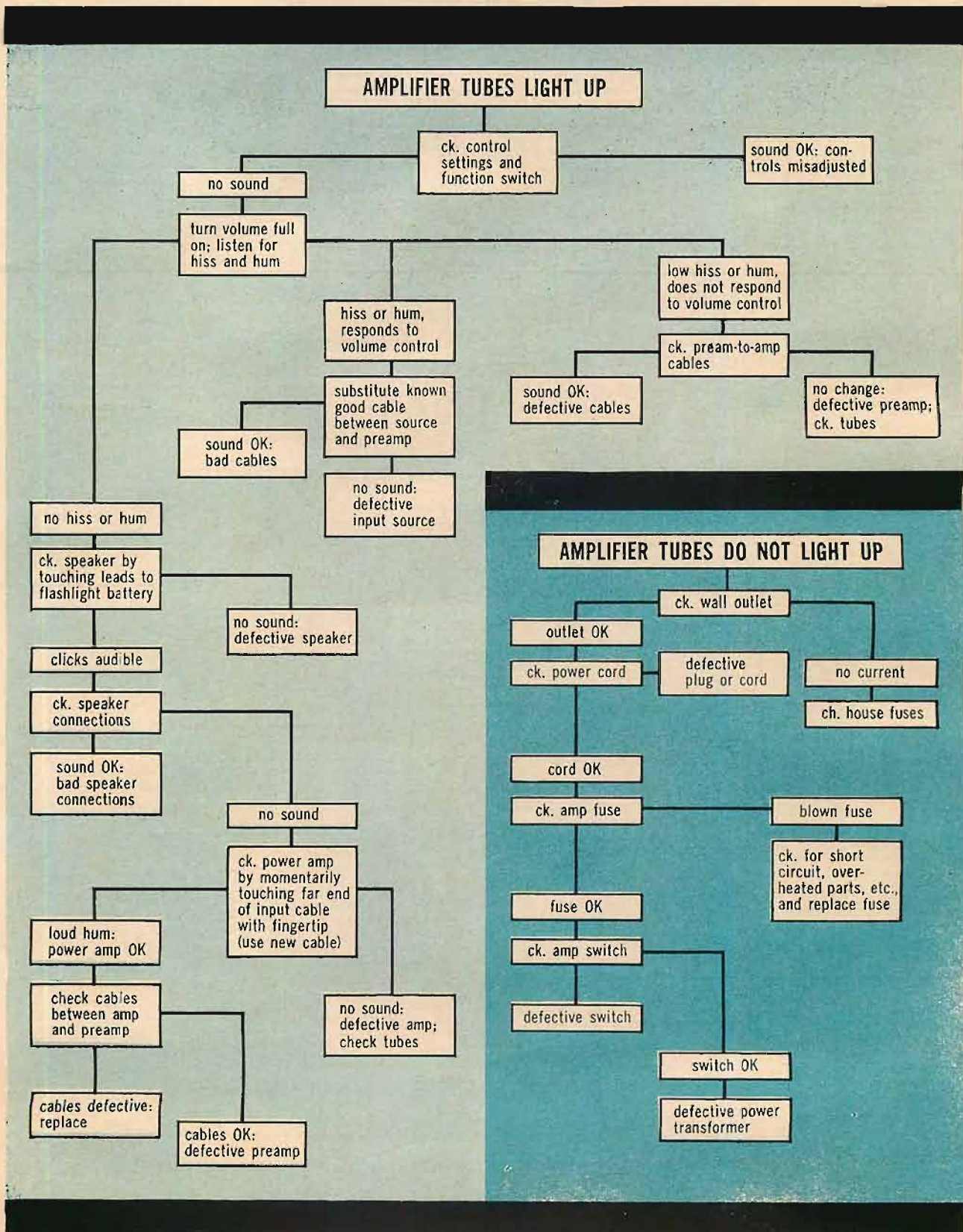



## THE MOST COMMON COMPLAINTS, THEIR PROBABLE CAUSES, AND SUGGESTED REMEDIES

GENERAL COMPLAINT	PROBABLE CAUSE	SUGGESTED REMEDY
Hum at minimum volume level (not proportional to volume).	Amplifier power supply defective.	Check rectifier tube; have amplifier checked.
Complete loss of sound in one channel.	Bad connection between amplifier and speaker.	Check wires between amplifier and speaker.
Loss of volume intermittently or for long periods.	Weak amplifier output tubes.	Check and replace tubes.
Intermittent clicks and pops.	Defective tube in amplifier.	Check and replace tubes.
Apparent "hole in the middle"; loss of deep bass; sound shifts with position of listener; poor localization.	Speakers out of phase.	Reverse one set of speaker leads at speaker or amplifier.
Buzzing sound in one channel.	Defective preamplifier tube; defective tweeter; loose component in speaker cabinet.	Replace or repair faulty components.
Ringing sound.	Microphonic tubes.	Gently tap each tube; replace noisy tube.
<b>PHONO INPUT</b>		
Distortion from loud passages.	Improper arm adjustment or worn stylus.	Recheck installation and balancing of arm; have stylus inspected.
Excessive hum at listening level; increases with volume-control setting.	Improper grounding; ground loop.	Check all input and preamp-to-amp connections for loose ground.
Stylus skips grooves.	Acoustical feedback; misaligned stylus.	Level turntable, rebalance arm, install foam rubber pad under base; check stylus alignment.
Excessive surface noise, accompanied by loss of highs.	Worn stylus; unbalanced arm.	Have cartridge and stylus examined; check arm installation and balance.
Wow or flutter.	Warped record, off-center record, or improperly operating turntable mechanism.	Clean drive belts, pulleys, and shafts with alcohol; lubricate according to manufacturer's instruction.
<b>TUNER INPUT</b>		
Distorted sound and/or noise.	Bad antenna connection.	Check antenna and lead-in wire.
Sound fades in and out.	Tuner muting control set too high; station too weak; interference.	Reset muting control; reorient antenna.
Distorted sound on weak stations.	Tuner out of alignment.	Have tuner aligned.





## GEORGE GERSHWIN

TWENTY-FIVE years after his death George Gershwin remains for the world at large America's most celebrated composer. His music—serious and popular—is universally loved and played; his personality, a mingling of brash youthfulness and artistic sensibility, remains ever fascinating. The drama of his tragically brief life is here recalled in rare photographs that recall Gershwin's colorful career: from his first job as a composer in 1918 to the last photograph in 1937.



# GEORGE GERSHWIN: A PICTURE PORTFOLIO

by Edward Jablonski

GERSHWIN ARCHIVES



*At the age of fifteen George Gershwin left New York City's High School of Commerce to become the "youngest piano pounder in Tin Pan Alley" for the Remick Company. In 1914 Tin Pan Alley was off Broadway on Twenty-Eighth Street.*

GERSHWIN ARCHIVES

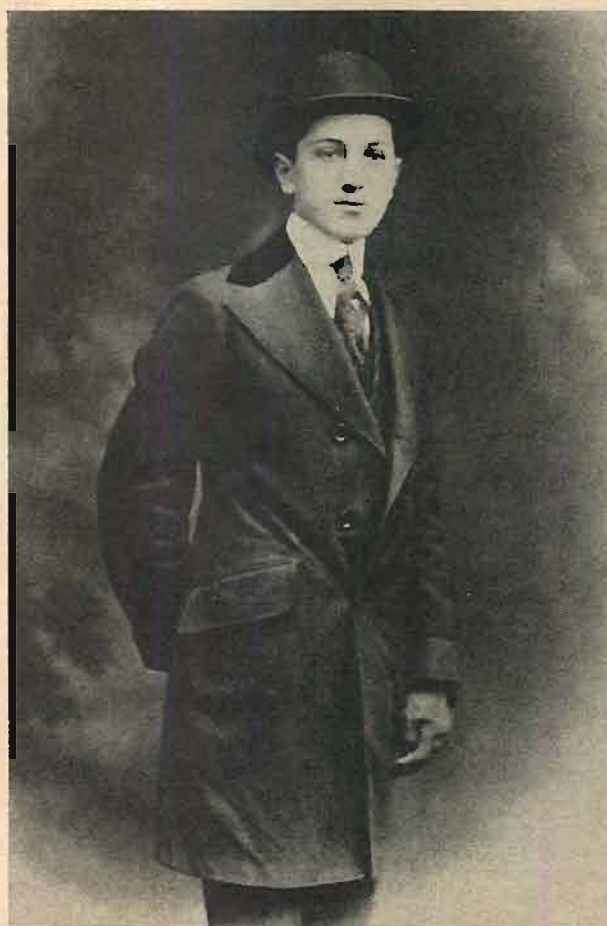

*George Gershwin at twenty, attired as he imagined a prospective Broadway composer should be. The occasion was the production of his first show, Half Past Eight, in December of 1918. The show expired in Syracuse and was never produced on Broadway.*

PHOTO FACING: WIDE WORLD PHOTOS



GERSHWIN ARCHIVES



*Nineteen-year-old George Gershwin reports for his first job as a composer, in February of 1918.*

GERSHWIN ARCHIVES

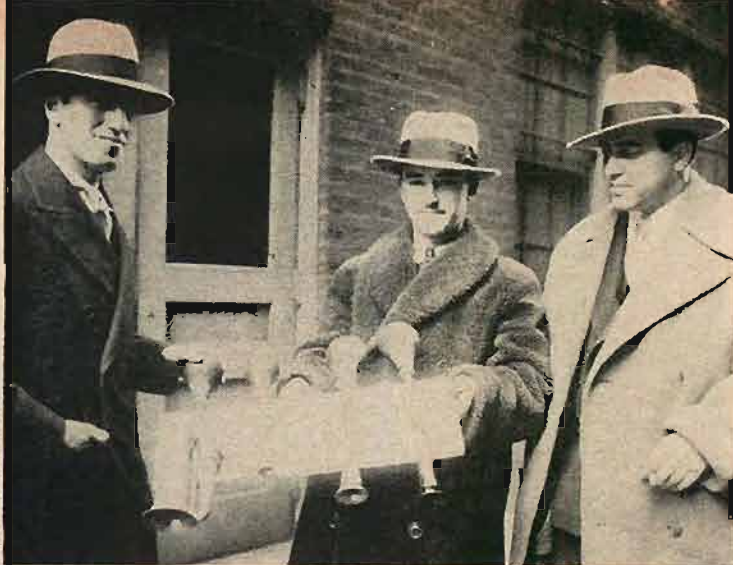

*In Pittsburgh for a performance of An American in Paris, Gershwin, a member of the orchestra, and tenor Richard Crooks pose with the authentic French taxi horns that Gershwin bought in Paris in 1918 for use in the score.*

GERSHWIN ARCHIVES



*George Gershwin in 1922, at the time he had written the music for George White's Scandals, which included a one-act work of his in opera form, Blue Monday.*

*Director Rouben Mamoulian and Gershwin shake hands at the premiere of Porgy and Bess on October 10, 1935.*

THE GERSHWIN YEARS







WIDE WORLD PHOTOS

*At a birthday party for Maurice Ravel on March 7, 1928. Gershwin awaits his chance to get at the piano. From left to right are conductor Oskar Fried, singer Eva Gauthier, Ravel seated at the piano, Tedesco of Naples, and Gershwin.*



GERSHWIN ARCHIVES

*On the set of the film Shall We Dance, late in 1936. Fred Astaire and Gershwin play a duet as Ira Gershwin looks on. Gershwin was impressed with Astaire's skill at playing the piano; Astaire, in turn, admired Gershwin's tap dancing.*

*Congregating at Lewisohn Stadium in the summer of 1931 for an all-American program are conductor Fritz Reiner, Gershwin, Deems Taylor, and Robert Russell Bennett.*

WIDE WORLD PHOTOS

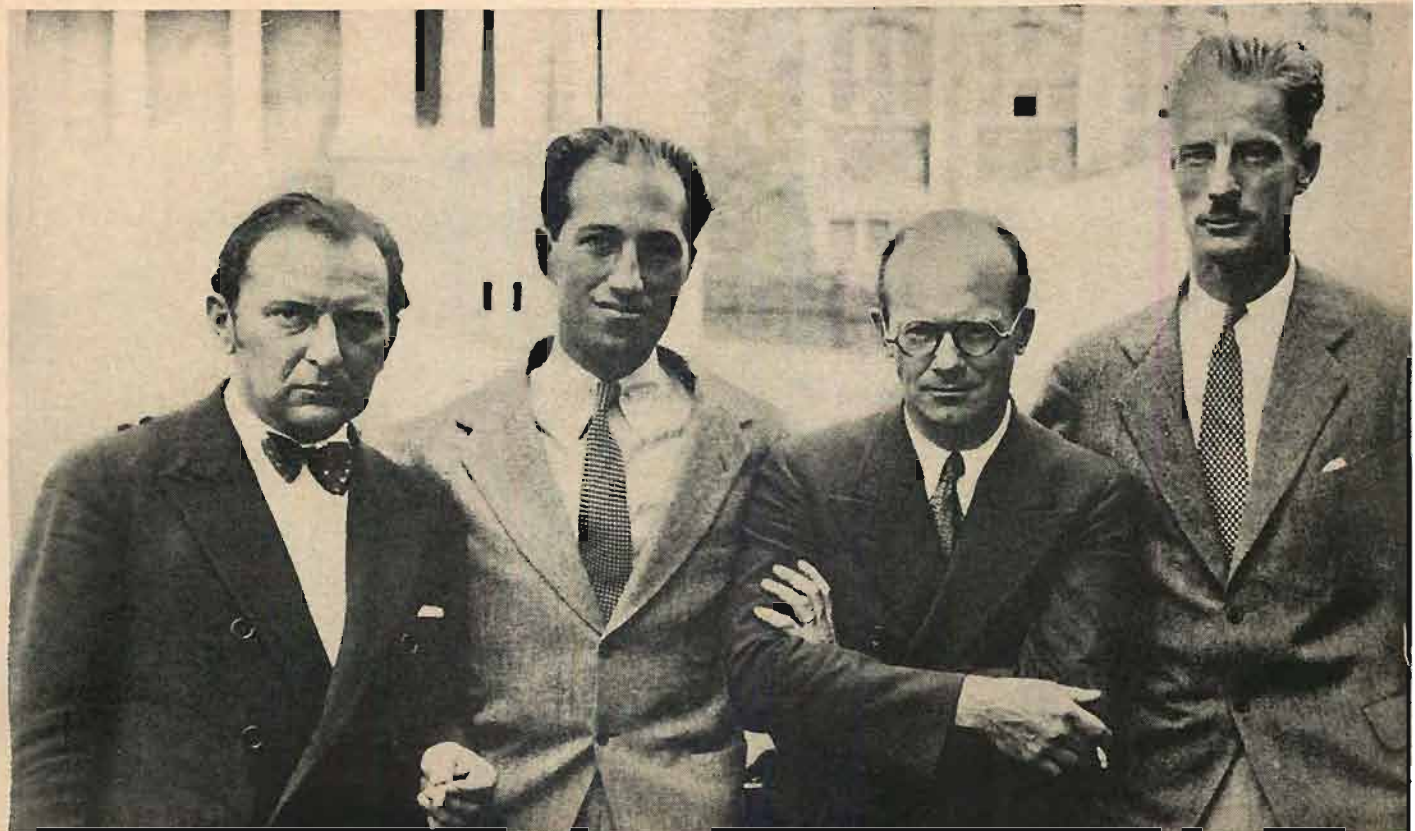





GERSHWIN ARCHIVES

*Gershwin conducts a rehearsal of the Los Angeles Philharmonic in February of 1937. During the concert Gershwin as the piano soloist stumbled over a passage in the Concerto in F, the first indication of his fatal illness.*

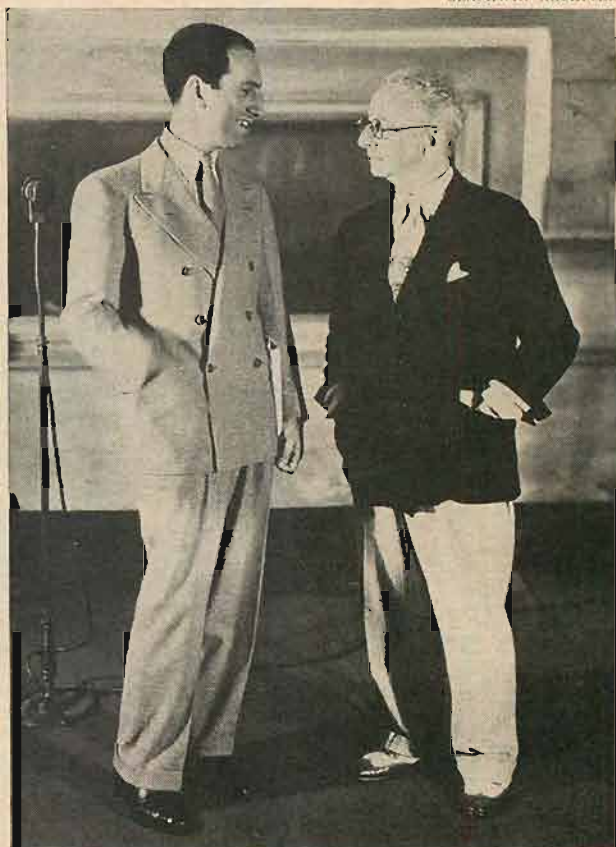

GERSHWIN ARCHIVES

*During 1934 Gershwin had his own radio program. Here he is in a radio studio with his good friend, composer Jerome Kern.*

*George and Ira Gershwin work on the songs for A Damsel in Distress in the living room of their Roxbury Drive home in Beverly Hills during the spring of 1937.*

GERSHWIN ARCHIVES







GERSHWIN ARCHIVES

*George Gershwin with his mother, Rose Bruskin Gershwin, in 1936.*



GERSHWIN ARCHIVES

*George and Ira Gershwin demonstrate some of their songs for Shall We Dance. Among these were They All Laughed and They Can't Take That Away From Me.*

*George and Ira Gershwin board the plane from Newark to Hollywood on August 10, 1936. They had just signed to write the music for a Fred Astaire-Ginger Rogers movie, Stepping Toes, which eventually became Shall We Dance.*



CULVER PICTURES

*The last photograph of George Gershwin. This candid shot was taken on June 16, 1937, less than a month before his death following an operation for a brain tumor.*



GERSHWIN ARCHIVES





## How to succeed in composing

**N**OT LONG AGO the present occupants of the White House in Washington, D.C. were hosts to a musical event that attracted wide attention in the public prints. The occasion was a recital given by Pablo Casals, the great cellist who, in self-exile from his native Spain, had long refused to play publicly in any country that gives diplomatic recognition to the Franco government.

Oddly enough, the big news was not the cellist's having made so spectacular an exception to his rule. It was, rather, the sheer novelty of such official recognition of the serious musical art having been given at all. The audience was, quite properly, an imposing aggregation of variously celebrated people. And, considering the matter superficially, there should have been nothing whatever astonishing about the fact that the guest list included a careful assortment of the United States' most distinguished composers. But, if one is to judge from the reports, no one could have been more winsomely, touchingly, gawkingly impressed by this presence than the composers themselves.

William Schuman was reported to have marveled: "Just think, we must be the first American composers to be here since that song-writing lawyer Francis Hopkinson used to drop in to see his friend Thomas Jefferson."

"I was deeply moved by the entire occasion—merely by the music of Casals but by the company in which it was played," said Leonard Bernstein. And Henry Cowell, it is said, added: "It's the closest thing we've ever had to being honored by our government."

*Time* summed up what seems to have been the prevailing attitude in a quote attributed to a Washington music critic: "The composers acted and talked like poor country cousins who had at last been let in the front door."

**T**HE EVENT itself, the journalistic attitude born of it, the all but pathetic gratitude felt by a congregation of distinguished creative musical artists symbolize, quite as poetically as anything that comes to mind, the standing of the composer in the United States. For if the problems attendant on being a full-time, practicing composer were not so seriously and personally affecting to so many serious and gifted people, the whole picture would be quite grossly funny.

Of course, no one undertaking a career in the arts—even the so-called popular arts—can look forward to the security that an aspiring dentist or even a plumber can. Those counting on it are fools, deranged, or possibly a little of both. But only in the United States does the composer of serious music find himself in so insecure a position. He may achieve recognition, first among his colleagues and then among members of that comparatively small part of the public who are aware of the fact that contemporary music exists; he may even achieve a parochial fame. But, with only a handful of phenomenal exceptions, he is a craftsman without a recognized profession, a worker with only the remotest hope of adequate recompense.

Working on the assumption that serious composers are more useful than detrimental to our national cul-



by WILLIAM FLANAGAN



## ...without really succeeding

tural image—an assumption that many critics and music lovers grant only with reluctance—we must be thankful that it is virtually impossible to elect a career in composition at a time of life other than extreme youth. Who else but the starry-eyed young would knowingly enter upon a professional training that is as arduous, long-range, expensive, and highly technical as that of a physician, say, and yet one that ultimately offers but the barest hope for minimal security or community status? This is not to say that the novice composer is unaware of these cold prospects—simply that struggle, deprivation, and lack of status are part of the very condition of youth and are more readily accepted by the young. More than one composer has approached the age of thirty to wonder with dawning horror what in heaven's name he has let himself in for. If he is a good composer the chances are that he has learned to do little else; composing is all he knows, and he is stuck with a profession that, so far as the “real” world is concerned, is not a profession at all, forced to forego all but the dimmest hope of the status and the creature comforts that are generally regarded as the rewards of maturity.

**L**EST these statements strike the reader as the exaggerated alarms of the self-interested—for I am, after all, a composer—let us look at related careers in music's sister arts. Talent, luck, hard work, personal charm, a measure of gall, a talent for politics and people, competent chiselling—all of these in proportion, brought together in the right place make for a successful career.

Anyone who undertakes a career in the arts—actor, painter, zitherist, cinematographer—takes a long, long chance. Especially if he is a pure creator rather than an interpretative artist. But—and this is an enormous “but”—a painter, given recognition, sells his painting for acceptable profit; an aspiring novelist, given publication, may become fashionable, famous, rich; a playwright, given production, may reap even greater reward from an art medium that is even more provincial in the United States than music is. Only the serious composer, along with the serious poet, must as a matter of course look to side-line occupation for mere economic survival, even if he is a recognized, performed talent. Only the composer takes the long chance that any career in the arts entails only to discover that at the end of the rainbow there is neither potted gold nor compensating prestige.

**I** SHOULD like partially to illustrate this peculiar state of affairs from my own career. Not because my case is special—I am, in fact, more fortunate than many of my contemporaries—but, rather, because I know my own circumstances best.

I am a composer still in my thirties, which, according to the generous standards that prevail, makes me a “young” composer. (As an actor or a writer, for example, I wouldn't be quite so young.) My first professional performances took place in New York about thirteen years ago. My music was first published about eleven years ago. My work has been consistently performed, first by professional societies dedicated to the





## HOW TO SUCCEED...

performance of new music at "chic" concerts, then, more gratifyingly, by reputable singers and instrumentalists. I have no unperformed music. In the last few years, I have begun to achieve major performance of my larger works; the orchestral pieces have been picked up by major symphony orchestras, and I have had a well-publicized showing of my only opera. I have been represented by three listings in the Schwann catalog. As a result of all of this, a fairly extensive critical evaluation (favorable, by and large) has been made of my work. I am, in short, a "recognized" "young" composer. Not so much of either as some, but more of both than many.

An uninformed observer, confronted with these credits, might assume that, while I have a good way to go, I should be encouraged and have no reason for acute dissatisfaction with my lot. But the facts are otherwise. For were it not for sideline activities that are tangential to my professional training, I should long ago quite literally have starved. My professional activity is, in truth, avocational, and activities arising out of my tangential abilities are vocational—or at least this is how the Internal Revenue Service views it.

AS A MATTER of fact, the wise composer in America is one who in many of life's day-to-day activities learns to conceal his prime occupation in favor of whatever way he really makes his living. One may, for example, be a recognized young composer who earns his keep by tossing salads at a Howard Johnson's restaurant. But, if he is applying for an apartment with the hope of getting it, he will do well to conceal his reputation as a composer in favor of his status as a salad man. Quite apart from the fact that the latter occupation offers the landlord a better guarantee of his ability to pay the rent, it renders the applicant less likely to be considered eccentric and therefore generally unreliable.

Nor does the Internal Revenue Service offer much leeway in deduction for the expenses that are involved in a composing career. It argues, quite reasonably, that a profession that earns no money is not a profession at all and therefore that the composer's request for consideration is the practical equivalent of a housewife's requesting privilege of deduction for the cost of her pet hobby—a weekly bridge club, say. A trip to the

Middle West to attend the world premiere of a composition, both from a personal point of view and from the point of view of the orchestra that plays it, is a must for a composer's career. Although its expense must come out of the composer's pocket (no orchestra would think of paying it), I have yet to encounter a tax man who considers it deductible.

THE FACT is that *all* of the works that have resulted from the practice of my craft for its own sake have, to this date, cost me more by their professional performance than they have earned me.

If this statement is surprising, it should be remembered that the composer's product, like any other, involves initial expense in the making. But, unlike most other products, it can be marketed "successfully" without even returning its initial cost.

A simple but typical illustration will demonstrate this point. Let us consider the economics of a ten-minute orchestral piece, in this case my own *Concert Ode*. Six months of work are expended in its creation. Once it is completed, about two hundred dollars are required to pay a copyist to prepare a clear score on transparent paper. Time, energy, highly skilled training, and money go into the work as a matter of course, even though the composer has not the faintest guarantee that he will so much as hear the piece in performance, let alone enjoy a profit from it.

So far, so good. The risk may be fair enough in so risky a way of life as the arts.

But, in following the career of this same work we find that the conductor of a major symphony orchestra accepts it for performance on a regular subscription series. If the piece is not controlled by a publisher, the composer must provide the several hundred dollars required for extraction of the orchestral parts from the conductor's score. If he has a publisher, the publisher *may* provide the parts. But the composer has gained only time, for more often than not the cost is recouped by the publisher as an "advance" against whatever performance royalties the piece may bring. The long and short of it is that the composer has gone deeply into the hole before a baton has been lifted.

But the piece is played and is successful with the public and the critics. During the following season it is played by other major orchestras—one of them nothing less than the celebrated one in Philadelphia. A few months later still, a professional recording of the piece is released.

It has, then, been brought close to the highest possible point of success for the work of a young composer, short of finding a place in the repertoire. But my dollar investment in the work has not, as of this writing, been fully returned.

But look for a moment at an instance where the func-



tion of a composer is connected with an art form that *can* support its creator. I was asked a couple of years ago to supply seven minutes of music, composed for a single clarinet, for a fifteen-minute playlet by a young playwright who has since risen to a position of fame and affluence. Straight off I received a hundred dollars in fee—decent enough remuneration for what amounted to an afternoon of work. But I know of nothing that better illustrates the irony of the composer's situation than the subsequent reward of this casual collaboration with a fellow artist. Through repeated productions of this briefest of plays, including two that were televised, I have been paid in excess of two thousand dollars with no end to further gain in sight. Not only has this afternoon of work contributed to my livelihood in a way that the success of my successful orchestral piece has not begun to, but it has brought me at least as much as the many performances and recordings of my music have over the thirteen years of my career as a professional composer.

**S**TILL, ironies and hard-luck stories do not alter the facts inherent to the system of free enterprise that is our national glory. If serious music is, by now, big business in certain of its manifestations, even the most missionary of composers can scarcely deny that serious contemporary music, American or otherwise, plays but a minutely fractional part in it. And, our society, according to its most fundamental tenets, allows that a man may do what he chooses with his life so long as he plays no havoc with the letter of the law in the doing. If he chooses so deviant a path as creative music, the choice is his; but he must recognize at the same time that he is equally "free" to accept, without just complaint, the hard socio-economic facts that accompany his choice.

This hard line is one that some musical leaders and critics hold to even as they applaud the current investigations instigated by an enlightened administration into the problem of subsidy for the performing musical arts. The composer can only regard this wryly as he notes that the plight of performing musicians, woeful as it may be, is certainly a bed of roses by comparison with his own.

Further, many knowledgeable persons will charge that, particularly during the years since the Second World War, the American composer is by and large in pursuit of a course of stylistic obscurantism that, whatever acclaim it may bring him in professional circles, is simply not filling the need of even the more sophisticated segments of the general concert public. It follows, perhaps rather tortuously, that he has a fine nerve asking either moral or economic support from his fellow man under such circumstances.

Bypassing arguments of aesthetics and style that are less than germane to my purposes here, one might con-

cede that there is perhaps a suspicion of truth to the charge, if not justice to the punishment.

But, even here, hasn't the cart been got somehow before the horse? If a composer writes "for an audience," is it surprising to find the composer in America writing for the only audience that does not take his value to be that of a second left hand to a right-handed man—specifically, for other composers and the specially oriented listener? The history of the last forty years of American music would seem, on close examination, to suggest that this is what has happened.

**W**HAT, then, the reader may well be asking, would at least this composer—the one engaged in writing this article—do? What are the solutions?

Words to fill volumes have been written about the more feasible avenues of hope. Federal subsidy has been suggested; so have increases in foundation activity, with more prizes, more grants, more commissions to create in their lucky recipients a temporary and entirely artificial sense of having solved problems that will nonetheless remain basic. I can shed no further light on any one of these proposals in spite of my ready acknowledgement of their stop-gap value.

It is in the last analysis, beyond the stop-gap, that one sees in the event at the White House a small, white flame of hope.

It was, at bottom, simply a concert and some dinner. Yet, in the listening and in the eating, a particular kind of attention was given to the Coplands, Barbers, Sessions, Thomsons, and Pistons that all of their major performances in impressive totality could not quite command. It was nothing more nor less than their country's supreme representative saying, in effect: "We know you are here, and we take pride in your accomplishments."

When, as a nation, we know that our composers are here and are proud of what they have accomplished—whether it interests or pleases us as individuals or not—then, and only then, will the role of the composer in the United States become anything better than a practical absurdity for the man of reasonable needs, tolerable vanity, and the thoroughly human and democratic desire to feel important to his fellows. It is then, moreover, that both the composer and the general listener will, each by his own means, narrow the appalling gap that continues to separate them.

---

*William Flanagan has emerged as one of the most gifted and sensitive of the post-World War II American composers. His Concert Ode has been recorded on the CRI label, and his The Lady of Tearful Regret is scheduled for future release. Mr. Flanagan regularly reviews new recordings for this magazine, specializing in the field of twentieth-century music.*



# SOUND and the QUERY

by J. Gordon Holt

a forum for eliminating the most common—and often most exasperating—problems of stereo hi-fi

## Reluctant Turntable

**Q.** My turntable—an idler-drive type with a four-pole motor and a heavy platter—takes almost four minutes to come up to full speed from a cold start. Even then, it sometimes requires a helping hand before it gets there. What can I do about this?

DONALD M. Fosco  
Rochester, N. Y.

**A.** Remove your turntable's platter, and clean its spindle with a clean rag soaked in gasoline. If there's a ball bearing at the bottom of the spindle well, remove it (by means of a screwdriver that has been magnetized), and clean it thoroughly. Then clean the spindle well itself, using a gasoline-soaked rag wrapped around a pencil.

Next, clean the inside rim of the platter (where the idler wheel contacts it), the outside rim of the idler tire, and the drive pulley on the motor. Finally, lubricate the entire unit as recommended by its manufacturer, and reassemble it (remembering to replace the ball bearing, if any).

If this doesn't clear up your trouble, the idler tension may be wrong or the motor may be defective. In either case, you'd best have the factory service it or else trade it in on a new turntable.

## New Life for Old Heads

**Q.** I am told that worn-out tape-recorder heads can be reconditioned to restore them to new condition. Is this true? If so, how do they go about replacing the worn pole pieces?

H. NESBITT  
St. Louis, Mo.

**A.** Most tape-recorder heads are so constructed that pole-piece wear

widens their magnetic gap, so these heads must be discarded when worn. The heads used in many professional and semiprofessional recorders, on the other hand, have a very deep magnetic gap, so appreciable wear can take place without widening the gap. As wear progresses, though, the rounded surface of the pole pieces flattens out, spreading the tape's contact force over a broader surface and thus reducing its contact pressure at the gap, causing high-frequency losses. It is possible to correct this condition by careful honing of the pole pieces, to restore their rounded shape and hence their original performance characteristics. But the honing operation is extremely delicate and requires skill as well as precision grinding equipment, so the cost of reconditioning makes it prohibitive except for heads that are initially very costly.

## Recorder Response

**Q.** I am considering buying a tape recorder that has a frequency response of  $\pm 2\frac{1}{2}$  db from 30 to 12,000 cycles at  $7\frac{1}{2}$  ips speed. If I feed this with a 30-to-16,000-cycle source, and listen to the tapes on good equipment, will this recorder reproduce the sounds with their original fidelity?

JOHN PARKER  
Norfolk, Va.

**A.** No recorder will reproduce sound with perfect fidelity, but an excellent one will come close enough that the difference won't worry anyone too much. The frequency-response rating you quoted for the recorder is not complete enough, however, to show whether or not it would audibly color the sound of its tapes. If most of the specified losses occur at the frequency extremes and the response variations between 30 and 12,000 cps deviate no more than  $\pm 1$  db, the recorder is excellent. If the deviation between 30 and 12,000 cps is greater than this, the sound will suffer accordingly. This is why it is often wiser to choose a machine that doesn't extend quite as far at the frequency extremes but has smoother response in between.

## Horns Versus Cones

**Q.** Which does the best job of reproducing the range from 600 to 5,000 cycles, a horn or a cone-type speaker? I'd like to know this in relation to price as well as in price-no-object terms.

JOSEPH MENTO  
Frankfort, N.Y.

**A.** It isn't easy to generalize about this. Both can be made to have very smooth response and low distortion. In terms of potential performance, top-price horns and cone speakers are about equally excellent. In the lower-price ranges, however, my experience is that mediocre cone speakers usually sound better than mediocre horns.

## In-Phase Wiring

**Q.** I am aware that the customary way of phasing loudspeakers is by equipping one with a phase-reverse switch, and then flipping this back and forth until they sound as if they are in phase. But is this trial-and-error technique always necessary?

If you use identical speakers for the two channels, and feed them from identical amplifiers, wouldn't identical connections between them assure correct phasing? In other words, if each amplifier's ground terminal were connected to the same terminal on each speaker, wouldn't this automatically put the speakers in phase with one another?

RAYMOND RAMQUIST  
Director, Audio-Visual Department  
DePaul University  
Chicago, Ill.

**A.** This would indeed assure correct phasing. The main reason why the trial-and-error method is recommended, though, is because it is not always possible to ensure that identical connections are maintained in both channels.

The problem, of course, is that in order to make sure that each ground terminal is connected to the same speaker terminal you must be able to distinguish between the two conductors of each speaker cable. If you use color-coded wires, or have the use of a continuity tester, this is no problem. But most speaker connections are made with ordinary lamp cord, which does not have color-coded wires. Some lamp cord does have a small molding seam running along one edge, and this can serve as a tracer for maintaining continuity. But when even this is lacking, or when the speakers are not the same, the phasing-switch trial-and-error technique is the only way of making sure of correct phasing.

In general, identical speakers will be properly phased when they are identically connected. Since there is always the possibility of human error in speaker manufacturing, though, a system that should be in phase but that sounds as if it isn't should be checked.



## BEST OF THE MONTH



## CLASSICAL

## BRUNO WALTER'S TESTAMENT—AND GUSTAV MAHLER'S

*A definitive recording of the Mahler Ninth Symphony*

**B**RUNO WALTER, the supreme humanist among the twentieth-century orchestral conductors, passed into eternity early this year after more than sixty years of glorious music-making. It is the good fortune of us who live on that we are able to continue to experience the humanism of Bruno Walter in all its compassion and strength in his recorded interpretations of the masterworks of Mozart, Beethoven, Brahms, Wagner, Bruckner, and Gustav Mahler.

COLUMBIA RECORDS

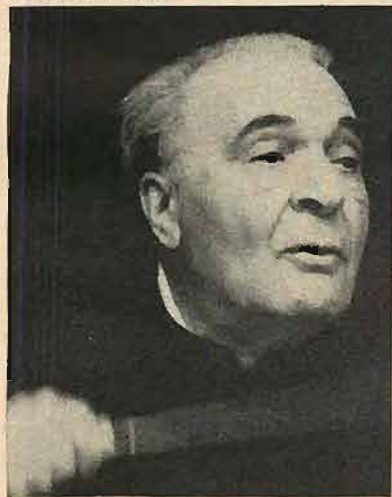

BRUNO WALTER  
*A glorious testament*

It was as a worshipful disciple of Mahler that the young Bruno Walter was launched upon his career as a conductor; and it was Bruno Walter who conducted in 1911 and in 1912 the world premieres of Mahler's two last completed masterpieces—works that Mahler himself was never to hear—*Das Lied von der Erde* and the Ninth Symphony. How fitting it is that Columbia Records should issue as a memorial to Bruno Walter the impassioned performance of the Mahler Ninth Symphony that he recorded in early 1961. As a fascinating supplement, this album also offers on one record (at no extra cost, incidentally) a series of rehearsal sequences from

the recording sessions, with illuminating commentary by producer John McClure, as well as portions of an interview with the conductor. Thus we have not only a view of Bruno Walter the musician but also a glimpse of Bruno Walter the man.

Few veteran record collectors will forget the experience of hearing Bruno Walter's recording of the Mahler Ninth Symphony that was issued on twenty 78-rpm sides by RCA Victor more than two decades ago. The tragic *(continued overleaf)*





impact of the music was intensified by the fact that it was taken from a public performance of the Vienna Philharmonic Orchestra on January 16, 1938, a scant two months before Hitler and his Nazis took over Vienna and drove Walter into exile for the second time within five years. That Mahler Ninth recording, with all its technical shortcomings, presented a reading of fiery passion—a document wholly unique of its kind.

The new Mahler Ninth as recorded by Walter has lost not one whit of the old passion, and it has gained in the interim an epic grandeur that obtains not merely for the turbulent first movement and the other-worldly finale but even for the grotesque and sardonic middle movements. There is no question but that this recorded performance represents the quintessence of Bruno Walter's interpretive art, as well as his definitive view of Gustav Mahler's greatest musical creation—surpassing even *Das Lied von der Erde*.

The Los Angeles and Hollywood musicians that recorded under Bruno Walter's baton during the last four years of his life had by 1961 cohered into a superb orchestra that was truly his, and it shows in every bar of this performance, whether

in the shattering climaxes of the opening movement, the delicacy of the second-movement *ländler*, the crystal-clear rendering of the thorny polyphony of the third-movement *Rondo-burleske*, or the now lush, now ethereal string sonorities of the poignantly drawn-out slow movement that brings the work to a close. Equally important, the Columbia production staff has done a superlative recording job, utterly true to the sound of Walter's orchestra and wholly free from any taint of gimmickry. The stereo sound is full-bodied, open, and wonderfully natural.

Together with the recent Columbia album of the Bruckner "Romantic" Symphony, this Mahler Ninth belongs among the real treasures of Bruno Walter's art on discs. Fortunately this is not the end of Bruno Walter's legacy as taped by Columbia, for among other things we can count on the Bruckner Seventh Symphony for release some time in 1962.

David Hall

© © MAHLER: *Symphony No. 9; Rehearsal Sequences From Mahler Ninth Recording Sessions; A Bruno Walter Interview*. Columbia Symphony Orchestra, Bruno Walter cond. COLUMBIA M2S 676 three 12-inch discs \$11.96, M2L 276 \$9.96.

## A GREAT SCHUBERT MASS

*Erich Leinsdorf  
reveals a  
major late masterpiece*



ERICH LEINSDORF  
*Drama and warmth for late Schubert*

**M**AGNIFICENT music, superb leadership, and a fine performance, all set down in rich and majestic sound, make Capitol's new recording of Schubert's Mass in E-flat under Erich Leinsdorf's direction one of the most significant record releases of the year. In the earlier Masses of Schubert there had been promises of a greater and more individual beauty to come. Here, then, is

the fulfillment, complete and overflowing, yet with still a promise of what might have been had not Schubert died at the age of thirty-one. Like the earlier masses, this is essentially a choral and lyrically homophonic work, with few extended solo passages. Yet, massive as it is, there is no monotony in this glorious work. *The Sanctus* is no less than tremendous, and the most original stroke



of all, the alternation of the lovely, almost pastoral *Incarnatus* with the dark-shaded *Crucifixus*, is deeply felt and makes no descent into mere pietism.

Erich Leinsdorf's conducting cannot be praised too highly, for he fully comprehends the nature of this work and presents it with unbroken musical and dramatic continuity. The playing of the Berlin Philharmonic is superb; the St. Hedwig's Cathedral Choir is admirable—one never senses strain, even in the most expansive passages; and the principals bring to the few passages for the solo quartet a heart-warming naturalness. The technical quality of the recording is worthy of the music in every respect—rich and sonorous, yet always clear. In particular, the breadth and depth of the stereo perspective is thrilling.

Ralph Bates

© © SCHUBERT: *Mass, in E-flat (D. 950)*. St. Hedwig's Cathedral Choir; Berlin Philharmonic Orchestra. Erich Leinsdorf cond. CAPITOL SP 8579 \$5.98, P 8579\* \$4.98.

## \*\*\*\*\* JAZZ \*\*\*\*\*

### THE PEERLESS ART OF BILLIE HOLIDAY

*Columbia's  
comprehensive  
anthology of Lady Day*

**I**F YOU'VE been waiting for a definitive collection of some of our best popular music, the new Columbia album, "Billie Holiday: The Golden Years" may be your reward. Comprising classic examples of the art of the greatest jazz singer we have had, this three-record boxed set clarifies the meaning of that army of critics and writers who, by way of operational definition, have pointed to Billie Holiday and said, "That's what a jazz singer is."

During that portion of her career encompassed by this album—essentially from 1936 to 1941—Billie Holiday extended the vocal repertoire of jazz beyond the blues to include popular songs, but she replaced the sentimentality implicit in many of their lyrics with her own sense of pathos and pitiless, diamond-hard realism. A host of present-day singers would have no concept of this approach if Miss Holiday had not shown them the interpretive possibilities. The important thing to remember is that such standards as *Them*



CBS TELEVISION

BILLIE HOLIDAY AND LESTER YOUNG  
*They made beautiful music together*

*There Eyes, These Foolish Things, Easy to Love* and *The Way You Look Tonight* were brand-new pop tunes when she first sang them, and may not otherwise have been remembered at all. These are among the choice items included in this indispensable collection.

The first few tracks are from 1933, when she still sounded like a genre singer of the period, but by 1936 she was able to make a melody instantly her own, as on *They Can't Take That Away From Me*, or *Love Me Or Leave Me*, often leaving the detailed structure of the tune behind to interpret it with a few economical notes that were its essence, as Louis Armstrong did before her, or as Lester Young was doing at about the same time.

The forty-eight numbers in this album take Miss Holiday from the beginning of her great period through its maturity in 1941, fittingly ending with *Gloomy Sunday*. Most of them are recorded with the superb small combos assembled under her name or Teddy Wilson's, and one can hear the evolution of small-band jazz, from series of solos to ensemble arrangements. Most notable of the musicians involved is Lester Young, her friend and powerful stylistic influence. He is magnificent on *This Year's Kisses* and *The Man I Love*, and most particularly on a remarkable duet with



Billie in *I Can't Get Started*, during a rare recording of a radio performance with the Basie band.

Although today's younger hi-fi buffs may not be overly impressed by the sound of this set (although the sound is at all times adequate and in some cases surprisingly good), it is the music itself that should make eminently clear to them what all the fuss about Billie Holiday is about.

Joe Goldberg

Ⓜ **BILLIE HOLIDAY:** *The Golden Years*. Billie Holiday (vocals); various orchestras. Forty-eight selections. COLUMBIA C3L 21 three 12-inch discs \$11.98.

## THE NEW STRENGTH OF SONNY ROLLINS

*A new  
RCA Victor album  
finds him in peak form*

**T**AKING its name from the fact that the artist tested his technique on the Williamsburg Bridge in lower Manhattan, Sonny Rollins' new RCA Victor album, "The Bridge," is the first by the tenor saxophonist since his return from a two-year sabbatical of rest, reflection, and practice. Obviously the leave of absence has had its salutary effects: the session is a brilliant reconfirmation of Rollins' leadership—with John Coltrane

SONNY ROLLINS

*He again asserts his leadership*



JOE ALPER

—of the modern jazz tenor saxophone domain.

As has been clear in his recent club appearances, Rollins did not try to change his style radically during his exile, but he now has a more authoritative, more relaxed method of playing that is marked by a warmer tone and sharpened wit. Rollins is still primarily a melodist, constructing ingenious and continually surprising thematic variations rather than concentrating on chordal patterning. But his beat now has even more sweeping strength, and he may well be the most flexible among the younger reedmen.

In this recital, Rollins' range of capacities is impressive. In the title number, for instance, he is dazzlingly swift and buoyant while remaining utterly controlled. His singular wryness adds a new dimension to sections of *Without a Song* and *You Do Something to Me*. On the ballad *Where Are You* Rollins is tender without being cloying.

Rollins has selected his sidemen well. Guitarist Jim Hall plays with a glowing, thoughtful lyricism that sets off Rollins' more aggressive intensity perfectly. The two, moreover, occasionally improvise collectively with a rare sense of mutual anticipation and understanding. The rest of the rhythm section is robustly functional.

Engineer Ray Hall, one of the most sensitive technicians at jazz record dates in New York, has balanced the quartet so that Hall's softer tone is not overshadowed and the rhythm instruments are never obtrusive. The stereo version is especially attractive since it enhances the passages of interplay between Rollins and Hall.

Nat Hentoff

Ⓜ Ⓜ **SONNY ROLLINS:** *The Bridge*. Sonny Rollins (tenor saxophone), Jim Hall (guitar), Bob Cranshaw (bass), Ben Riley and H. T. Saunders (drums). *Without a Song*; *John S.*; *The Bridge*; and three others. RCA Victor LSP 2527 \$4.98, LPM 2527 \$3.98.

## \* ENTERTAINMENT \*

### THE ORIGINAL-CAST NO STRINGS

*Richard Rodgers'  
great vehicle  
for Diahann Carroll*

**R**ICHARD RODGERS, as the most celebrated figure in the musical theater, had everything to lose in *No Strings* by going it



alone as his own lyricist for the first time in his career. But Capitol's new album reveals a sophistication and fitness of lyrics that is on a level as high as his music.

It is not hard to detect qualities that were associated with the late Lorenz Hart and the late Oscar Hammerstein II. But the score has qualities of lyricism and emotion that are unmistakably Rodgers in both words and music. And though he has written his songs alone, he has been fortunate in securing arranger Ralph Burns who has done some daring things in the theater that are also noticeable on the record.

Two of the most striking of these innovations were scoring the work for a conventional orchestra minus the string section, and the use of solo instruments as part of the action to integrate song and story. For the opening song, *The Sweetest Sounds*, a flute is used to accompany Diahann Carroll while a clarinet backs up Richard Kiley. A trombone is very much in evidence in *Love Makes the World Go Square*, and the feeling of extreme boredom in *Eager Beaver* is conveyed perfectly through a muted trumpet. All this makes for a highly effective aural presentation, of which Capitol has taken full stereophonic advantage.

In her first starring role, Diahann Carroll establishes herself as one of the most exciting musical-comedy singers today. Her songs give her the opportunity to interpret a variety of emotions, which she does to perfection. There is some roughness to Richard Kiley's voice, but his skill as an actor enables him to invest his numbers with honesty and conviction. *Stanley Green*

© ® NO STRINGS (Richard Rodgers). Original-cast recording. Richard Kiley, Diahann Carroll, Polly Rowles, Noelle Adam, Alvin Epstein, Bernice Massi, Don Chastain; orchestra, Peter Matz cond. CAPITOL SO 1695 \$6.98, O 1695 \$5.98.

## THE CLANCY BROTHERS AND TOMMY MAKEM HIT THE BIG TIME

*Their new Columbia album  
finds them still  
fresh and unspoiled*

**F**ROM THE back room of the White Horse Tavern in Greenwich Village the Clancy Brothers and Tommy Makem have gone to such more



THE CLANCY BROTHERS AND TOMMY MAKEM  
*Their Irish is up and doing*

formal and more expensive night retreats as the Gate of Horn in Chicago, where their new album, "Hearty and Hellish," was recorded. They have also moved from their own small Tradition label to far-flung Columbia. Despite all the temptations inherent in their new affluence, the Clancys, as they show here, have lost none of their roistering impudence and wit.

As is their custom, the Clancys sing mostly of the pleasures of courting, drinking, and rebellion. They have also included their shatteringly sardonic version of the anti-war tune, *Johnny, I Hardly Knew Ye*. Among the newer material is *Mr. Moses Ri-Tooral-I-Ay*, a comic tale of an Irish Jew arrested by an ambitious British policeman who cannot tell Hebrew from Gaelic.

The Clancys are at their best when recorded before a live audience because theirs is a decidedly gregarious approach to music-making, and they become all the bolder when the audience is clearly on their side, as it was this night at the Gate of Horn. The engineering is first-rate, and the stereo setup increases the illusion of sitting at a front table and being directly addressed by these brash but enormously appealing actors-turned-minstrels. *Nat Hentoff*

© ® THE CLANCY BROTHERS AND TOMMY MAKEM: *Hearty and Hellish!* Tom, Pat, Liam Clancy and Tommy Makem (vocals), Bruce Langhorne (guitar), Frank Hamilton (banjo), Herb Brown (bass). *Irish Rover; The Barnyards of Delgaty; October Winds; Courtin' in the Kitchen; The Jolly Tinker; Jug of This; Johnny McEldoo; Whiskey, You're The Devil; Mountain Dew; When I Was Single; The 23rd of June; The Rising of the Moon; God Bless England; Mr. Moses Ri-Tooral-I-Ay; Johnny, I Hardly Knew Ye*. COLUMBIA CS 8571 \$4.98, CL 1771\* \$3.98.



# HANS KNAPPERTSBUSCH CONDUCTS FIDELIO

with the Bavarian State Opera Orchestra and Chorus



"Knappertsbusch's FIDELIO...welds the exalted solos and choruses into a memorable experience."

WASHINGTON STAR

Sena Jurinac as Leonora  
Jan Peerce as Florestan  
Maria Stader as Marcellina

**Other new releases:**

BACH: St. John Passion, conducted by Scherchen.  
HAYDN: Seven Last Words of Christ, Scherchen.  
MARTIN: Le Vin Herbé, conducted by Victor Desarzens, with the composer at the piano.



3 record set —  
WST-318 (Stereo) \$17.94.  
XWN-3318 (Monaural) \$14.94

Free — Complete new catalog. Write Dept. HS9, Westminister Recording Co., Inc. a subsidiary of ABC-Paramount Records, Inc. 1501 Broadway, N.Y. 36.



The Westminister listener is the selective listener

"Stereo thorough and most convincing...sound clear and deep". — HIGH FIDELITY





# classics

Reviewed by RALPH BATES • WILLIAM FLANAGAN

DAVID HALL • GEORGE JELLINEK • IGOR KIPNIS

### Explanation of symbols:

- Ⓜ = monophonic recording
- Ⓢ = stereophonic recording
- \* = mono or stereo version not received for review

Ⓢ Ⓜ BACH: *Brandenburg Concerto No. 5, in D Major*. BACH-STOKOWSKI: *Three Chorale-Preludes: Ich ruf zu Dir, Herr Jesu Christ; Nun komm der Heiden Heiland; Wir glauben all an einen Gott*. Fernando Valenti (harpsichord); Anshel Brusilow (violin); William Kincaid (flute); Philadelphia Orchestra, Leopold Stokowski cond. COLUMBIA MS 6313 \$5.98, ML 5713\* \$4.98.

Interest: Bach-Stokowski  
 Performance: Heavy-handed  
 Recording: Warm but balances are poor  
 Stereo Quality: Very good

Stokowski's way with Bach had a useful purpose in the 1920's and 1930's when he was permanent conductor of the Philadelphia Orchestra: most Bach was generally unknown, especially the organ works, and the conductor did much to familiarize music lovers with works they otherwise might seldom have heard. Now that a large proportion of the same music is available on LP's in original versions for the authentic instruments in far more faithful performances, Stokowski's efforts seem regressive. The conductor's transcriptions of three organ chorale-preludes are merely up-to-date versions of his familiar 78-rpm recordings; the Philadelphia Orchestra sounds as it did then, but the whole style of performance is old-fashioned. The same must be said about the Fifth Brandenburg, which the conductor has not previously recorded. A beautiful-sounding ensemble cannot excuse the over-all conception that features a heavy orchestra, incongruous sweeping phrases, swollen sonorities, and ridiculous ritards (the first of many occurs after the opening ritornello and before the entrance of the solo instruments). To be sure, Stokowski does include the harpsichord, but it is made audible only at its most important statements and in the cadenza (very excitingly played by Fernando Valenti, though a poor splice in the middle must be noted). Except for

this balance deficiency, the sound is very good. I. K.

Ⓢ Ⓜ BACH: *Concerto for Flute, Violin, Harpsichord, Strings, and Continuo, in A Minor (S. 1041); Harpsichord Concerto No. 4, in A Major (S. 1055); Harpsichord Concerto No. 5, in F Minor (S. 1056)*. Ralph Kirkpatrick (harpsichord); Aurèle Nicolet (flute); Rudolf Baumgartner (violin); Festival Strings Lucerne, Rudolf Baumgartner cond. DGG ARCHIVE ARC 73176 \$6.98, ARC 3176 \$5.98.

Interest: Great harpsichord concertos  
 Performance: Mostly very good  
 Recording: Excellent  
 Stereo Quality: Excellent

The second disc of the Deutsche Grammophon traversal of the complete harpsichord concertos of Bach includes two



THURSTON DART  
*Authentic Bach with wit and grace*

typical and fairly popular examples of this form as well as the generally neglected A Minor Concerto, a counterpart in its scoring to the Fifth Brandenburg, and one of the most taxing of all Bach's works for the solo keyboard. Both the soloist and the orchestra sound a little stiff in the Fourth Concerto, with a slightly perfunctory middle movement and some heavy-handedness in the strings, but the remaining performances should rank among the best on records with a really exciting, fast-paced, and powerful account of the difficult A Minor. The sound in both stereo and mono versions is excellent. I. K.

### RECORDING OF SPECIAL MERIT

Ⓢ Ⓜ BACH: *Six French Suites*. Thurston Dart (clavichord). L'OISEAU-LYRE SOL 60039 \$5.98, OL 50208\* \$4.98.

Interest: Bach keyboard delights  
 Performance: Remarkable  
 Recording: Lovely  
 Stereo Quality: Just right

In his sleeve note for his performance of the French Suites, Thurston Dart argues persuasively for the use of what was supposed to have been Johann Sebastian Bach's favorite keyboard instrument, the clavichord. Even more eloquent than his scholarly discussion, however, is the performance itself, clearly the best disc version to date of all six suites. Dart's playing is technically admirable and learned in execution (ornaments, appoggiaturas, tempos, etc.) but far from a dry, musicological approach. The intimate clavichord, whose dynamic range is limited, differs from the harpsichord in that variations in volume are possible as well as miniscule subtleties of tone. Dart realizes this technique completely—his touch is extremely gentle, and his conceptions are warm and sensitive. His refined use of the *Bebung* (a vibrato achieved by a slight up and down motion after the key has been depressed) is particularly expressive. Aside from all technicalities, Dart's playing of the French Suites is enjoyable simply as music—graceful, witty, tender, and wonderfully moving. In order that the six suites might be contained on a single disc, all repeats have been omitted, not a serious fault. Both in terms of performance and sound, this recording must be considered one of the most successful of the delicate-voiced instrument. The stereo version provides just enough added dimension for complete realism, but the listener must be warned to keep the volume level far down for accurate reproduction, to even less than one might use for playing back a guitar recording. I. K.

Ⓢ Ⓜ BACH: *St. John Passion*. Phyllis Curtin (soprano); Eunice Alberts (contralto); Waldemar Kmentt (tenor); Frederic Guthrie (bass); John van Kesteren (tenor), Evangelist; Otto Wiener (bass), Jesus; Franz Holetschek (organ). Vienna Academy Chorus and Vienna State Opera Orchestra, Hermann Scher-



chen cond. WESTMINSTER WST 319 three 12-inch discs \$17.94, XWN 3319 \$14.94.

Interest: Liturgical landmark  
Performance: Bach-Scherchen  
Recording: Excellent  
Stereo Quality: Excellent

Scherchen's approach to Bach's earliest setting of the Passion (the *St. John* was written at the time of the composer's appointment to Leipzig) is, as one might have expected, untraditional: tempos in particular are subject to unconventional ideas, so that, for example, the recitative "Then Pilate therefore took Jesus and scourged him" or the middle section of "It is finished" are dramatically and musically too slow, while "I follow thee" (the soul after Christ) is rushed. Not all tempos are ill-chosen (the beginning of "Beloved Saviour, wilt thou answer?" is excellent), but Scherchen's individual views sometimes have little bearing on the text, and his treatment of chorales includes a sentimental, almost sticky slowing down for the last line. The chorus, not as steady a body of voices as the best European groups, sounds as though its members had been cautioned to sing in half voice, often to the detriment of the dramatic sentiment (i.e., an exasperatingly lightweight, almost whispered "Jesus of Nazareth" instead of an angry retort). Of the soloists, the only truly outstanding member is the excellent Evangelist, who manages quite frequently to rise above the conductorial constrictions to deliver a full range of emotion. The others, whether through lack of color, vocal control, or stylistic insight, do not add distinction to a set that already has so many interpretive drawbacks. There are, to be sure, real moments of excitement and conviction, but, over-all, either the recent London stereo version or the older monophonic Archive performance is infinitely preferable. The Westminster recording, both mono and stereo, is first-rate, but the stereo version (there is some groove damage on side two of my copy) is especially impressive in its feeling of transparency. Notes and complete texts are included. I. K.

© © BARTÓK: *The Miraculous Mandarin; The Wooden Prince—Suite*. Southwest German Radio Orchestra, Baden-Baden, Rolf Reinhardt cond. Vox STPL 512040 \$4.98, 12040\* \$4.98.

Interest: Bartók for the dance  
Performance: Adequate  
Recording: So-so  
Stereo Quality: Mostly quite good

The idea of coupling these evocative dance scores of Béla Bartók's relatively early years is excellent, but the project—as a technical production—is less than ideal. The interpretations are rather coarse, and the instrumental execution,

while it in no way misrepresents the music, is, in many details, less than first-rate. Neither is the recording likely to win any prizes. W. F.

© © BARTÓK: *The Miraculous Mandarin*. SHOSTAKOVICH: *The Age of Gold*. Philharmonia Orchestra, Robert Irving cond. CAPITOL SP 8576 \$5.98, P 8576\* \$4.98.

Interest: Flashy contemporary ballet  
Performance: Sharp and bright  
Recording: Ditto  
Stereo Quality: Fine

Few people would mention the names of Béla Bartók and Dmitri Shostakovich in the same breath, yet these scores have something in common. Both are brash and abrasive, both fantastic in expressive aura, and both use tonal dissonance with the kind of glee that one rarely encounters in composition today. But I have always had my doubts about the viability of the

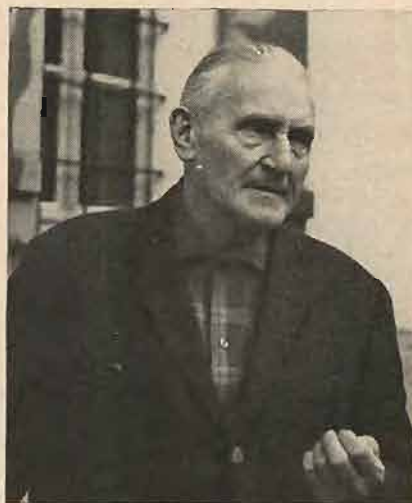

HERMANN SCHERCHEN  
*An individual approach to Bach*

Bartók as a concert piece. Full of energy and invention as it is, it specializes rather heavily in effects, and one longs for something a little more musically tangible. Still, it is a brilliant dramatic conception, an orchestral tour de force, and Irving has given it, as well as the Shostakovich, a vividly intense reading. The recording is full-bodied and elegantly detailed. W. F.

BARTÓK: *Rhapsody No. 1* (see BLOCH).

© © BEETHOVEN: *Fidelio*. Sena Jurinac (soprano), Leonora; Jan Peerce (tenor), Florestan; Maria Stader (soprano), Marcellina; Murray Dickie (tenor), Jacquino; Gustav Neidlinger (baritone), Pizarro; Dezso Ernster (bass), Rocco; Frederic Guthrie (bass), Don Fernando; Georg Paskuda (tenor), First Prisoner; Paul Neuner (bass), Second Prisoner. Bavarian State Opera and Chorus, Hans Knappertsbusch cond.

WESTMINSTER WST 318 three 12-inch discs \$17.94, XWN 3318 \$14.94.

Interest: Beethoven's one opera  
Performance: An unhurried view  
Recording: Good  
Stereo Quality: Well-planned

There is an aura of unhurried grandeur about Knappertsbusch's *Fidelio*. Even those unconvinced of the fundamental rightness of his stately approach will find much to admire in the inner logic of his reading, in his many revelations of orchestral detail, in the painstaking clarity of his articulation. This reading, however, commands more respect than passionate enthusiasm, for it lacks the propulsive spark essential to make this thorny opera an exciting musical experience.

Everything here is molded to the conductor's image. Sometimes the singers pay the toll—it is difficult to make Rocco's "Gold" aria or Pizarro's "Ha, Welch' ein Augenblick" effective at such a leisurely pace. Yet there are occasions, particularly in some expressive passages allotted to Leonora, when Knappertsbusch's conducting proves very rewarding.

Among the singers, only Stader and Dickie seem perfectly cast and in full, relaxed command of their assignments. Peerce's voice no longer follows his musical instincts with the freedom and easy flow remembered from the great Toscanini broadcast (RCA Victor LM 6025), but that was eighteen years ago. However, it would still be difficult to find Peerce's peer among other current Florestans. Sena Jurinac, on the other hand, never had the heroic thrust required for such crucial scenes as "Abscheulicher" or the final ensemble. It is a tribute to her artistry that her warm-toned and always musical singing often makes the listener forget this.

For Pizarro, Neidlinger supplies the sinister aura and the appropriate vocal color but not the power. Ernster's Rocco is expertly drawn, but his singing is inconsistent in tone quality and frequently unfocused. The Don Fernando of Frederic Guthrie is unfortunately ineffective. The Munich orchestra and chorus, including the two solo Prisoners, respond admirably to Knappertsbusch's exacting leadership.

Today's choice of recorded *Fidelios*: Vox VBX 250—fine performance hampered by outdated sound; RCA Victor LM 6025—aging, incomplete, but in many ways incomparable; and Decca DX 147—an estimable compendium of compromises. Westminster alone offers up-to-date sonics. Angel has another *Fidelio* in the offing, with Otto Klemperer conducting, and prospective buyers may wish to wait for a comparison. G. J.

© BEETHOVEN: *Sonata No. 7, in D Major, Op. 10, No. 3*. RACHMANINOFF: *Ten Preludes From Op. 23* and



Op. 32. Sviatoslav Richter (piano). COLUMBIA ML 5725 \$4.98.

Interest: Major personality  
Performance: Excellent  
Recording: Below standard

This Carnegie Hall recording of Richter's third concert offers finely performed early Beethoven, with all Richter's faculties in full play. But for many, the chief value of the record will lie in the superb reading of the ten Rachmaninoff preludes. The sound, however, is so much below standard, being blurred in the middle and lower registers, that the disc can hardly be recommended except to students of the piano and to hero worshippers, amongst whom I seem to be one.  
R. B.

#### RECORDING OF SPECIAL MERIT

© ® BEETHOVEN: *Sonata No. 19, in D Minor, Op. 31, No. 2*. SCHUMANN: *Fantasia, in C Major, Op. 17*. Sviatoslav Richter (piano). ANGEL S 35679 \$5.98, 35679\* \$4.98.

© BEETHOVEN: *Sonata No. 18, in E-flat, Op. 31, No. 3; 32 Variations in C Minor; Ecossaises in E-flat; Rondo in G Major, Op. 31, No. 2; Seven Ländlerische Tänze in D Major*. Maria Greenberg (piano). ARTIA MK 1568 \$4.98.

© ® BEETHOVEN: *Sonata, in D Minor, Op. 31, No. 2; Sonata, in E-flat, Op. 31, No. 3*. Clara Haskil (piano). EPIC BC 1158 \$5.98, BC 1157 \$4.98.

Interest: Piano masterworks  
Performances: Good to fine  
Recordings: Good to excellent  
Stereo Quality: Appropriate

Three fine but overlapping Beethoven piano records in one month is God's plenty and the collector's dilemma. Direct comparison may therefore be in order. In the remarkable sonata in D Minor, the choice between Richter and Haskil is extremely difficult, for both offer authoritative conceptions, powerfully expressed. Richter's is more personal and thoughtful and Haskil's more dramatic, especially in the first and last movements. In the Adagio, Richter's intensity is perhaps the greater; certainly it is so in the recitative passages. In the last movement, however, Richter's superior delicacy and liquid tone win my vote.

In the two performances of the sonata in E-flat, Haskil's mature vitality is in contrast with Greenberg's sharply outlined virtuosity. Greenberg is strong, swift, and precise in her fingerwork but at times a little breathless and too violent in her dynamic contrasts. But she is very good. Haskil's minuet, however, is mar-

velous, haunting in its nostalgia, while Greenberg gives it a formal and exteriorized treatment. The other side of this disc, however, contains an outstanding performance of the 32 Variations. This is the best version on records, with finely displayed virtuosity coupled with sound judgment.

Richter is said to regard himself not as an intellectual pianist but as an intuitive one. If that means an extraordinary ability to seize upon the emotional content of every work and to combine this with genuine command of style, then he is right. His highly individual playing of the Schumann fantasia pulses with urgency. As to quality of recording, all three discs are quite good.  
R. B.

#### RECORDING OF SPECIAL MERIT

© ® BEETHOVEN: *Sonatas for Piano and Violin (complete); Twelve Variations on "Se vuol ballare"; Six German Dances; Rondo in G*. Aaron Rosand (violin); Eileen Flissler (piano). Vox SBVX 517, 518 (two albums, each with three 12-inch discs) \$8.95 per album, VBX 17, 18 \$8.95 per album.

Interest: Beethoven sonata cycle  
Performance: Lucid  
Recording: Good  
Stereo Quality: Mostly good

The first of many admirable qualities in these sets is the fire and infectious enthu-



(S)P-8580

## The Gorgeous Sound of Wagner and Strauss

Here is the first modern coupling of these two magnificent meditations on love and death. Erich Leinsdorf creates poetry in sound with Wagner and Richard Strauss in their most passionate music. This exciting album is a worthy companion to Leinsdorf's best-selling "The Sound of Wagner" (S)P-8411... and "The Sound of Richard Strauss" (S)P-8548. Of the latter, HI FI/STEREO REVIEW said, "The Leinsdorf disk is distinguished by superb orchestral playing and really dazzling reproduction."



© CAPITOL RECORDS, INC.

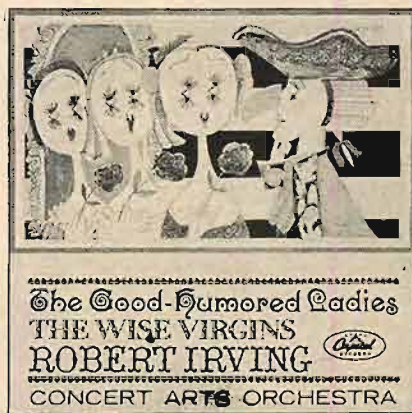

(S)P-8583

## The Sparkling Sound of Bach and Scarlatti

The wit, grace, and melody of Bach are happily transcribed by Sir William Walton into one of the most delightful ballets in the modern repertoire... "The Wise Virgins." The collaboration of Tommasini and Scarlatti in "The Good-Humored Ladies" is just as glittering, just as polished and stylized. The conductor: Robert Irving, "...the best conductor of ballet music in the world" —THE ATLANTIC. This new album, premiering both works in superb Stereo, bears out that opinion.

Other superb Robert Irving ballet albums on Capitol: The Miraculous Mandarin (Bartok)/The Age of Gold (Shostakovitch) (S)P-8576/The Seasons (Glazounov) (S)P-8551.



siasm communicated by Aaron Rosand and Eileen Flissler. There have been more powerful statements of the "Kreutzer," more poetic and reflective readings of the poignant Adagios of the "middle group," but it is hard to find a more persuasive projection of the exuberant glow that suffuses the first three sonatas, the exultant No. 5 ("Spring"), or the light-hearted No. 8, the most uninhibitedly joyful in the entire sequence. The fast movements are often taken at a hazardously brisk tempo, but the artists surmount all tests of articulation and intonation. Rosand plays with glowing tone, sensitive phrasing and flawless technique, and Miss Flissler (who is Mrs. Rosand) is a responsive partner whose pianism is a rare composite of grace, incisiveness, and accuracy.

Vox favors more stereo separation than do most other producers of sonata discs, but the two instruments still form a natural blend in bright and crystal-clear sound. There is one curious instance—during several measures in the first movement of Sonata No. 3—when the violin suddenly switches from the left to the right of the piano.

There are six discs in the series instead of the customary four. Thus the grooves are not overcrowded, with one sonata placed per side and an entire disc devoted to the "Kreutzer." The low price makes this set an especially attractive bargain, and the relatively unfamiliar works thrown in as a bonus are most welcome choices, played with engaging lightness and humor. *G. J.*

#### RECORDING OF SPECIAL MERIT

Ⓢ Ⓜ **BEETHOVEN: Symphonies: No. 1, in C Major, Op. 21; No. 9, in D Minor, Op. 125 ("Choral").** Chicago Symphony Orchestra and Chorus, Fritz Reiner cond. RCA Victor LSC 6096 two 12-inch discs \$11.96, LM 6096 \$9.96.

ANDRE VANDERNOOT

*A virile reading of Berlioz's Symphonie Fantastique*



Interest: Early and late masterpieces  
Performance: No. 1 good,  
No. 9 very good  
Recording: Excellent  
Stereo Quality: Fine

This Beethoven Ninth has all the qualities one would expect of a reading by Fritz Reiner leading his own orchestra. In the first movement it has drive and relentlessly controlled rhythm. The Scherzo is as elemental as it should be. Hushed intensity and power sustain the great line of melody in the slow movement. The last movement is a wholly confident and successful effort.

I do not feel that Reiner's playing of the First Symphony can be praised in the same degree. Reiner presses the work too hard, reading it with the future Beethoven too much in mind. The recording of both works is very good, rock-firm and clean-edged, with the orchestral perspective well displayed. *R. B.*

Ⓢ Ⓜ **BEETHOVEN: Symphony No. 5, in C Minor, Op. 67; Egmont Overture, Op. 84.** Berlin Philharmonic Orchestra, Wilhelm Furtwängler cond. DEUTSCHE GRAMMOPHON LPM 18724 \$5.98.

Ⓢ Ⓜ **MOZART: Symphony No. 39, in E-flat (K. 543); HAYDN: Symphony No. 88, in G Major.** Berlin Philharmonic Orchestra, Wilhelm Furtwängler cond. DEUTSCHE GRAMMOPHON LPM 18725 \$5.98.

Interest: Classic interpretations  
Performance: Excellent  
Recording: Adequate

Here are four fine examples of Furtwängler's art. The details of the music are felt afresh, and out of them the sense of the whole is derived. The subtle tension in Furtwängler's playing of the introduction to the Mozart E-flat symphony

is a case in point. It is the same with his Haydn, which makes the most of the imaginative wit and the delicacy of the music. I do not know when these recordings were made (Furtwängler died in 1954), but, even as sound, they stand up very well. *R. B.*

#### RECORDING OF SPECIAL MERIT

Ⓢ Ⓜ **BERLIOZ: Symphonie Fantastique, Op. 14.** L'Orchestre National, André Vandernoot cond. COMMAND 11009 SD \$5.98, 11009 \$4.98.

Interest: Romantic cornerstone  
Performance: Excellent  
Recording: Excellent  
Stereo Quality: Demonstration-type

If you want to show off your stereo equipment, the *Symphonie Fantastique* of Berlioz might well be the work to select, especially when it is given the sweeping and virile performance it is here and the recording is of the quality provided by Command on this disc. This record reproduces the orchestral choirs and their separate members with astonishing fidelity. But after a while you may come to feel, as I did, that they sometimes fail to blend as they should. The woodwinds have an almost excessive saliency. In effect one is sitting in Row A rather than in Row Q. Yet reservations give way to unalloyed pleasure at the authenticity of the performance. *R. B.*

Ⓢ Ⓜ **BLOCH: Concerto for Violin and Orchestra. BARTÓK: Rhapsody No. 1 for Violin and Orchestra.** Roman Totenberg (violin); Vienna State Opera Orchestra, Vladimir Golschmann cond. VANGUARD VSD 2110 \$5.95, VRS 1083 \$4.98.

Interest: Rhapsodic modern concertos  
Performance: Vigorous  
Recording: Good  
Stereo Quality: Fine

Bloch's Concerto for Violin and Orchestra—the composer's single gesture in the medium—represents him, as ever, wearing his heartfelt lyricism on his sleeve. And, while much of Bloch's output may not stand the test of time, this work is impressive for its masterly construction, its glowingly idiomatic violin writing, and its almost discomfiting sincerity and integrity. The performance is elegant: Totenberg sustains the long, sinewy line with excellent control and an impressive sense of phrasing. Golschmann's way with the orchestra has strength and feeling: he has not confused intensity with breast-beating. I am less convinced by the performance of the Bartók work. Solid, musicianly, and shapely the reading is, but it wants somewhat in charm and animation. The recording is excellent. *W. F.*

(Continued on page 66)



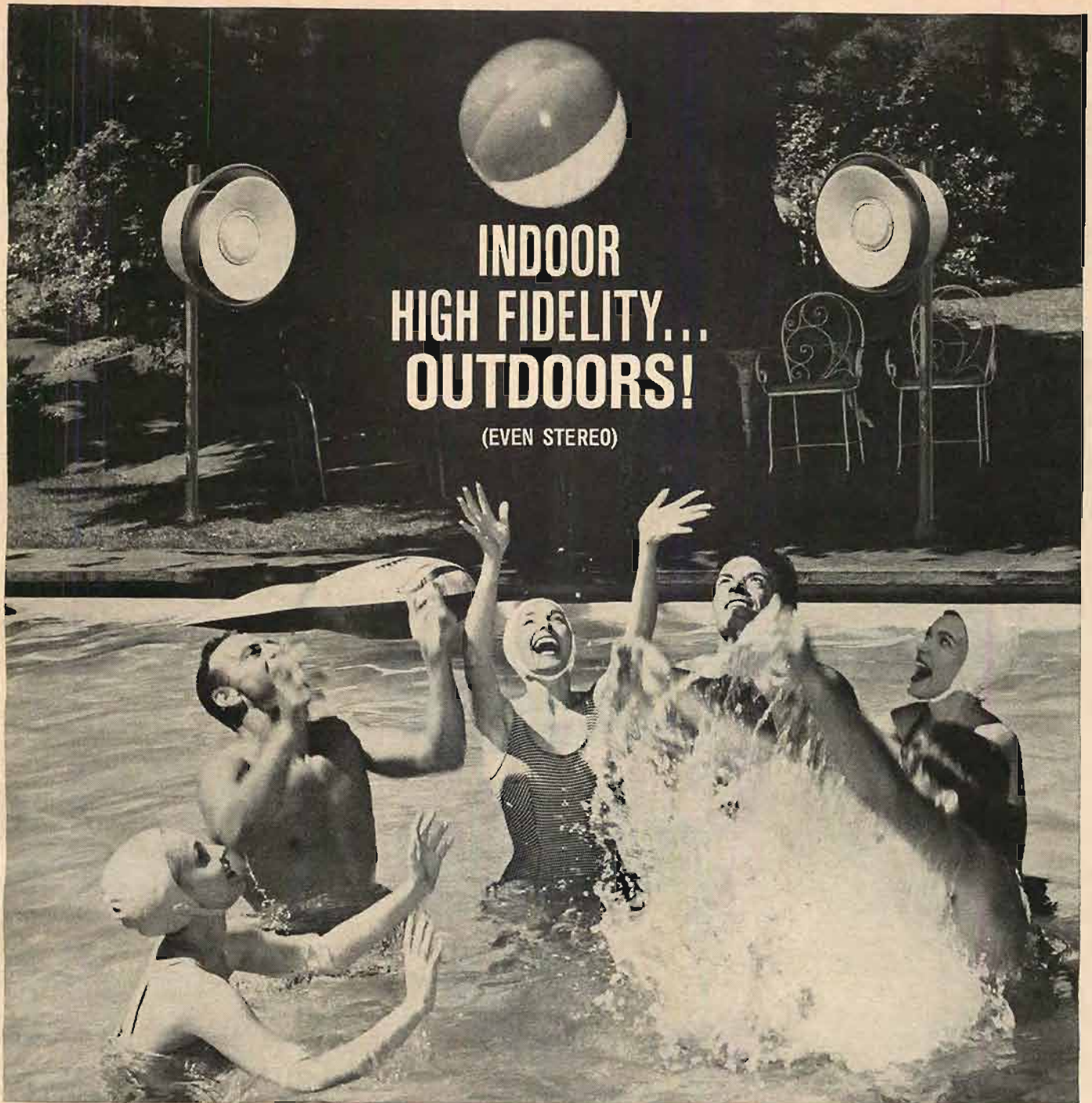

# INDOOR HIGH FIDELITY... OUTDOORS!

(EVEN STEREO)

with **UNIVERSITY** true outdoor high fidelity speaker systems

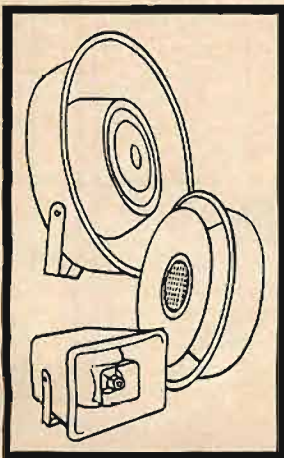

Now—outdoor systems that not only promise high fidelity performance—but deliver it. Just as they do in concert halls around the world, and for all the astronaut countdowns. Now these same superb outdoor speaker systems—systems chosen by discerning music lovers as well as top government sound engineers—are yours: to perk up your barbecue with frankfurters and fugues; to make mere swimming a new and exciting experience; or to bring the finest indoor concerts to your backyard!

You can connect a University outdoor speaker system (or two, for stereo) to the speaker terminals of your radio, TV set, phono or hi-fi amplifier and thrill to full-bodied high fidelity outdoors—at any time. Because they're totally weather-proof, they stay outdoors for good. Why hardly anything short of a hurricane can mar their performance. And they can be put anywhere—at patio or pool, on the house, a pole, a shelf, a fence—even on a tree. All you need is a screwdriver; adjustable 'U' brackets make installation a snap!

Interested? Really interested in how outdoor high fidelity speakers can glorify your summer and make the neighbors sit up and take notice? Just write: Desk D-7, University Loudspeakers, White Plains, N. Y.

## MUSIC UNDERWATER, TOO!

That's right. For the penultimate in outdoor living, without ever missing a note when you dive into the pool, University offers—in limited supply—the same underwater speakers that are required equipment in commercial and luxury resort pools. Write for separate information about the MM-2FUW and the MM-2UW underwater speakers. Just another 'first' by University.



A Division of Ling-Temco-Vought, Inc.



**RECORDING OF SPECIAL MERIT**

© 1968 BRAHMS: *Clarinet Quintet, in B Minor, Op. 115.* WAGNER: *Adagio for Clarinet and String Quintet.* Alfred Boskovsky; members of the Vienna Octet. LONDON CS 6234 \$5.98, CM 9301\* \$4.98.

Interest: Mature, relaxed Brahms  
Performance: Excellent  
Recording: Excellent  
Stereo Quality: Very pleasing

A lovely work, this clarinet quintet of Brahms. The Vienna Octet players accord it a fluent and unforced performance, full of thought and poetry, almost giving the sense of improvisation.

Much of the credit must be given to the clarinetist for his wonderfully phrased melodic line and a tone that is never pinched, even in the quietest passages. All four movements are played well, but the Adagio is outstanding. It is rapt and quiet, yet it achieves drama in the central aria episodes without breaking the impression of reverie. R. B.

© 1968 BRAHMS: *String Sextet, in B-flat Major.* New York String Sextet. 20TH Fox S 4000\* \$5.98, 4000 \$4.98.

Interest: Youthful Brahms  
Performance: Good  
Recording: Adequate

The New York String Quartet here gives a good performance of this early and optimistic score of Brahms. Its classical outlines are displayed clearly, and its themes are set forth with thought and feeling. The Andante, with its six not entirely lucid variations, is given clarification, and the Scherzo lives. Roughness, indeed, there is, but that is in Brahms, too. The last movement has its *joie de vivre*, and its close exults. A good performance, but the upper strings are often rough and wiry. R. B.

© 1968 CARTER: *Double Concerto for Harpsichord, Piano, and Two Chamber Orchestras.* KIRCHNER: *Concerto for Violin, Cello, Ten Winds, and Percussion.* Ralph Kirkpatrick (harpsichord); Charles Rosen (piano); Chamber orchestra, Gustav Meier cond. Tossy Spivakovsky (violin); Aldo Parisot (cello); Chamber orchestra, Leon Kirchner cond. Epic BC 1157 \$5.98, LC 3830\* \$4.98.

Interest: Top scores by top Americans  
Performance: Presumably authentic  
Recording: Excellent  
Stereo Quality: Uncommonly good

The last decade has seen the sudden emergence of Elliott Carter from the upper echelon of America's most promising younger composers to his present eminence, at fifty-four, as one of America's most accomplished musical creators—one whose excellence is acknowledged internationally. The Double Concerto here recorded (written on a commission from the Fromm Foundation) tells us why. Carter has developed a musical style that is at once recognizable as his own, and has, moreover, achieved genuine musical innovation—not in harmony, where it is most commonly sought nowadays, but in rhythm, or, to be more precise, in the area of rhythmic and contrapuntal independence.

One observes this in his two monumental and relatively recent string quartets (Columbia ML 5104, RCA Victor LSC/LM 2481). The Carter magic reaches even more ambitious heights in the Double Concerto. Here, whole instrumental combinations and keyboard units, each operating with separately styled complexes of harmony, form massively complicated blocks that seem to function as separate voices. Carter's explorations of the harpsichord, for example, as harmonically complex as they are in themselves, seem to act in precisely the same way that a single contrapuntal strand does in the music of Bach.

This is not music for the timid or the conventional-minded. But those with open minds and genuine curiosity are invited into the world of a man who may well be a major figure in the history of contemporary music.

(Continued on page 68)

# Compare...

## DAYSTROM STEREO/HI-FI KITS



### for value

Compare the features of this deluxe Daystrom AM-FM Tuner: 12-tube circuit, FM automatic frequency control, flywheel tuning, separate tuning "eyes," FM multiplex adapter output jack. Compare this low price!

Kit DA-286  
\$84.95



Listen to the solid power and fine fidelity of this stereo amplifier-pre-amp . . . 36 watts (18 per channel) at IHFM standards . . . with four stereo inputs, clutched volume controls, separate ganged tone controls, styled in the sparkling Daystrom motif of beige vinyl-clad steel and brushed anodized aluminum. Look at this low price!

Kit DA-282  
\$79.95



Enjoy FM in Stereo with this Daystrom Multiplex Adapter kit . . . easy to build circuit complete with cabinet and cables. Check this low price!

Kit DA-330  
\$34.95



Bring the wonders of high-fidelity FM radio to your home easily and economically with this Daystrom FM Tuner kit. Wide-band circuit features factory-built "front-end," multiplex adapter output, automatic frequency control, flywheel tuning, and cabinet. Extra value at this low price!

Kit DA-287  
\$49.95

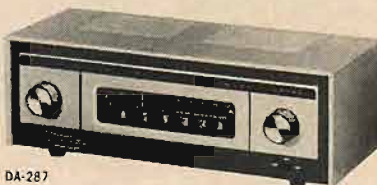

### for easy assembly

Compare the ease of Daystrom kit methods with any! Multi-color manuals tell what and how! Parts packed in order of use; factory-installed hardware.



### for performance

Compare the thrilling Daystrom Stereo/Hi-Fi performance . . . clear, quiet, and dynamic. See and hear these quality components . . .



at your nearest  
Daystrom dealer

DAYSTROM PRODUCTS CORPORATION  
BOX 167 / ST. JOSEPH, MICHIGAN





This summer: what precision 4-track recorder offers a special bonus? **AMPEX** Fine Line 1200.

Now: buy the Ampex Fine Line 1200 recorder/player — and take your choice of additional equipment. Free. Choose an Ampex 818 microphone kit with factory matched microphones for stereo recording, bases, cables and connectors. (Retail value: \$75.) Or you can have two Ampex 2012 amplifier/speakers for the price of one—complete for stereo playback! (Want just one speaker? Ampex will give you one 2012 at half-price.) Best news of all: with the Ampex Fine Line 1200 you get the only 4-track home recorder built to professional



standards. Three new heads for narrow-track recording and playback. Plus a precision tracking technique and tape guidance system to keep the tape in Fine Line alignment from reel to reel. Never any cross-talk. Just high fidelity sound. Take advantage of this special offer now at your local participating Ampex dealer. July 2 through September 1. It comes from the only company providing recorders and tape for every kind of application: Ampex Corporation, 934 Charter Street, Redwood City, California. (Offer is good in the U.S.A. only.)



RECORDING OF SPECIAL MERIT

© ® DVOŘÁK: *The Spectre's Bride*, Op. 69. Drahomira Tikalova (soprano), Beno Blachut (tenor), Ladislav Mraz (baritone); Czech Philharmonic Orchestra and the Czech Singers Choir, Jaroslav Krombholc cond. ARTIA ALP (S) 196/197 two 12-inch discs \$11.96, ALP 196/197\* \$9.96.

Interest: Quite a discovery

Performance: Absorbing

Recording: First-rate

Stereo Quality: Good

The element of dramatic urgency, often lacking in Dvořák's operas, is abundant in his dramatic cantata *The Spectre's Bride*, composed on commission from the British publishing firm of Novello for an English tour in 1885. Based on a text from K. J. Erben's anthology of Bohemian folk poetry—a source of a number of significant Dvořák inspirations—this is a grisly tale of a departed lover who returns from the beyond to claim his distraught bride. His appearance is dramatized with great skill and imagination, and the eerie ride of the lovers toward a mysterious destination recalls the cumulative agitation and overhanging terror of the Goethe-Schubert *Erkönig*. A hair-raising *danse macabre* climaxes the episode, with good finally triumphing over evil. The integration of solo voices with the powerful orchestra, and the evocative use of the chorus, are masterly. Dvořák created and sustained an atmosphere of horror with music alone, and with beautiful music at that: his exceptional melodic gifts find full expression here.

The performance is a tour de force for which conductor Krombholc and the engineering staff may jointly be complimented. Neither Miss Tikalova nor Mr. Blachut—well known from other Czech recordings—is a particularly appealing vocalist, but their persuasive characterizations and thorough absorption in the music could hardly be bettered. The baritone, Ladislav Mraz, who performs the vital task of the narrator and who carries most of the burden in the stirring final scene, is exceptional in every way.

In addition to the original text, the set contains good background notes but also the Novello translation, which substitutes *prim* and awkward Victorian English for the earthy original. But on musical values alone, *The Spectre's Bride* represents one of the highest marks of Czech music.

G. J.

FAURÉ: *Dolly* (see DEBUSSY).

© ® HAYDN: *The Seven Last Words of Christ*. Virginia Babikian and Ina Dressel (sopranos); Eunice Alberts (contralto); John van Kesteren (tenor); Otto Wiener (bass); Vienna Academy Chorus  
(Continued on page 71)



ROBERT AND GABY CASADESUS  
*Irresistible in the four-hand French repertoire*

It is odd to recall that Leon Kirchner, when he emerged on the American musical scene, was widely regarded as an "advanced" composer. The concerto recorded here (another Fromm commission) sounds just barely on the safe side of conventional today. Kirchner has yet to consolidate into his own work many of the solutions to the problems of rhythmic variety and textural relief that composers of the last decade have brought to contemporary chromaticism. I do not mean to suggest that Kirchner's concerto is without considerable merit; merely that this, his newest work, finds him quite where we found him in the early Fifties. His growth has been slow.

This is, in any case, an important record for anyone interested in contemporary music. Epic has done a superb job in its production.

W. F.

CHABRIER: *Trois Valses Romantiques* (see DEBUSSY).

© ® COPLAND: *Appalachian Spring*—*Suite*. *Billy the Kid*. London Symphony Orchestra, Antal Dorati cond. MERCURY SR 90246 \$5.98, MG 50246\* \$4.98.

Interest: Twin Copland classics  
Performance: Excellent  
Recording: Handsome  
Stereo Quality: Just

While this appropriate coupling of Copland's classic ballet scores is excellent in almost every way, it appears with at least two strikes solidly against it. *Appalachian Spring* is available in at least one preferable performance (Copland's own, with the Boston Symphony on RCA Victor), and *Billy the Kid* may be had in two other more preferable readings, in its suite form (Copland's own, with the London Symphony on Everest, and Bernstein's reading with the New York Philharmonic on Columbia). Furthermore,

while there is a distinct virtue in the present disc for the felicity of its coupling, the same may be had in Ormandy's monophonic Columbia version in a performance that, taken altogether, is as good as this new one with the additional bonus of presenting the only recording of the complete *Appalachian Spring*.

To sum up: commendable performances on a recording that is thoroughly admirable (except the apparent necessity of recording the first part of *Billy* at the end of side 1). However, both works have been given more idiomatic readings elsewhere.

W. F.

CUSHING: *Cereus* (see IMBRIE).

RECORDING OF SPECIAL MERIT

© ® DEBUSSY: *Petite Suite*. SATIE: *Trois Morceaux en forme de Poire*. CHABRIER: *Trois Valses romantiques*. FAURÉ: *Dolly*. Robert and Gaby Casadesus (piano). COLUMBIA MS 6323 \$5.98, ML 5723\* \$4.98.

Interest: Four-handed French charm  
Performance: Lovely  
Recording: Clear  
Stereo Quality: Fine

This record should be all but irresistible to anyone except the listener who cannot abide things French. The program is first-rate down to the last note, and its performance is perfection. Note, for example, the superbly poker-faced humor that the Casadesus duo brings to the Satie *Three Pieces in the Shape of a Pear*, and the exquisite, small-scaled singing line that floats over the accompaniment of Fauré's *Dolly*. Four-hand, one-piano playing can be one of the most gratifying personal pleasures in musical performance. The Casadesus team, on this record, invites us to overhear their fun. Record buyers should accept the invitation.

W. F.



and Vienna State Opera Orchestra, Hermann Scherchen cond. WESTMINSTER WST 17006 \$5.98, XWN 19006 \$4.98.

Interest: Galant oratorio  
Performance: Warm and dramatic  
Recording: Fine  
Stereo Quality: Clearly defined

When Haydn received a commission from the Cathedral of Cadiz to write a work for the Good Friday service, he responded in 1785 with a setting of the *Seven Last Words of Christ* for orchestra. The music achieved great popularity, although the subject matter of necessity called for slow tempos, and Haydn's score consisted of seven adagios preceded by a solemn introduction and followed by a presto depicting the earthquake. Haydn subsequently rewrote the work for both string quartet and solo keyboard (1787), and then in 1797 gave the music its final setting, as recorded here, for orchestra, soloists, and chorus. Musically, except for the drama of the introduction, the soft chanting of the words before each of the sections, and the final earthquake, this is good Haydn but something less than a heartfelt setting of the text—certainly a far cry from Bach's gripping account of the Passion. For me, this music suggests an element of graciousness and bewigged gentlemen that seems slightly incongruous, as in the almost gay (and very charming) melody to the words, "I thirst." Scherchen provides a warm performance—a bit individualistic in places but dramatically very effective—and the solo and choral singing are commendable. The spacious sound, clearly defined as to location in the stereo version, is excellent, but there is some slight pre-echo on the second side. Texts and translations are included. I. K.

HAYDN: *Symphony No. 88* (see BEE-THOVEN).

© IMBRIE: *Legend for Orchestra*. CUSHING: *Cereus—Poem for Orchestra*. San Francisco Symphony Orchestra, Enrique Jorda cond. CRI 152 \$5.95.

Interest: For Imbrie  
Performance: Sounds good  
Recording: Above CRI par

The *Legend* by Andrew Imbrie (b. 1921) is the good news of this CRI release. An extended, intensely original exploration of a long, one-movement formal mold, it sustains interest from first to last. Its orchestration is personal, and its highly dissonant, richly chromatic harmonic style sounds unlike that of any similarly oriented composer. It's an impressive work, and from the hand of a composer who, at forty-one, may yet be an important one.

The Charles Cushing (b. 1905) work is post-Impressionist in manner but dif-

JULY 1962



## Precious handful of sound

This hand cradles the finest pickup cartridge in the world.

The ADC-1 high compliance stereo cartridge is the key to pure, truthful sound—the very heart of living sound within the microgroove.

This cartridge is years ahead of its time. It is made for people of sound judgment and rare appreciation of the hidden qualities, the subtleties of timbre and tone, which all too often vanish before they have uttered their message of fidelity.

In combination with the new Pritchard tone arm, you have the most remarkable system available today.

For complete information on the ADC-1 and the new Pritchard tone arm, write today.

### ADC-1 Specifications

TYPE: Miniature moving magnet  
SENSITIVITY: 7 millivolts per channel  $\pm 2$  db at 1,000 cps (5.5 cm/sec recorded velocity)  
FREQUENCY RESPONSE: 10-20,000 cps  $\pm 2$  db  
CHANNEL SEPARATION: 30 db, 50 to 7,000 cycles, comparable everywhere  
STYLUS TIP RADIUS: .0006" (accurately maintained)

STYLUS TIP MASS: .5 milligrams

LATERAL AND VERTICAL COMPLIANCE:  $25 \times 10^{-6}$  cms/dyne minimum

RECOMMENDED LOAD IMPEDANCE: 47K ohms

RECOMMENDED TRACKING FORCE: .75 to 2 grams in top quality arms

MOUNTING CENTERS: Standard 1/2" and 7/16" centers



**AUDIO DYNAMICS CORPORATION**

Pickett District Road • New Milford, Conn.

CIRCLE NO. 7 ON READER SERVICE CARD

71



ferent from what the phrase might suggest. It is gratifyingly free from cliché; it is made with impressive skill; and it sustains interest.

The performances are good, and the recorded sound ranks with CRI's better achievements. *W. F.*

**KIRCHNER:** *Concerto* (see **CARTER**).

#### RECORDING OF SPECIAL MERIT

© ® **LOCATELLI:** *L'Arte del Violino, Op. 3: Concerto No. 1, in D Major; Concerto No. 8, in E Minor; Concerto No. 9, in G Major.* Roberto Michelucci (violin); I Musici. Epic BC 1155 \$5.98, LC 3827\* \$4.98.

Interest: Violin concerto origins  
Performance: Superb  
Recording: Excellent  
Stereo Quality: Excellent

Pietro Antonio Locatelli (c. 1695-1764), who is said to have studied with Corelli, made important contributions to the

#### RECORDING OF SPECIAL MERIT

© ® **ORFF:** *Carmina Burana.* Czech Singers Choir; Czech Philharmonic Orchestra; soloists, Vaclav Smetáček cond. PARLIAMENT PLP(S) 161 \$2.98, PLP 161\* \$1.98.

Interest: Good buy in popular Orff  
Performance: Uninhibited  
Recording: Brilliant  
Stereo Quality: Spacious

This low-price disc of Carl Orff's most popular work is an excellent buy on all counts. The vocal soloists may not be the world's greatest, but the all-important choral work is very nearly the best to be heard on any available recording, and the playing of the Czech Philharmonic is full of fiery zest and is excellently recorded. Not the least fascinating aspect of this recording is the way in which the performers add a bit of Czech folk flavor to the music's elemental rhythms. Indeed, the production as a whole is superbly uninhibited, as it should be. All things considered, it finds its peer only

*Landes Jesu Christi nach dem Evangelisten St. Matthäus (St. Matthew Passion).* Dietrich Fischer-Dieskau (baritone), Evangelist; Johannes Richter (bass), Jesus; Horst Schäfertöns (tenor), Pilate; Udo Steinhauer (bass), Caiphás; Hans-Dieter Rodewald (tenor), Judas; Wolf Zeddies (tenor), First False Witness; Harry Oshitzki (tenor), Second False Witness and Peter; Helga Ruth (alto), Pilate's Wife; Ingrid Schulz (soprano), Ancilla I; Lore Fischer-Dieskau (soprano), Ancilla II; Hugo Distler Choir, Berlin, Klaus Fischer-Dieskau cond. DGG ARCHIVE ARC 73172 \$6.98, ARC 3172 \$5.98.

Interest: Seventeenth-century Passion  
Performance: Exceptional  
Recording: Excellent  
Stereo Quality: Splendid

Although Heinrich Schütz's setting of the *St. Matthew Passion* (ca. 1664) may seem undeveloped and primitive to ears accustomed to the greater variety of timbres in Bach's version, the earlier music closely resembles the traditional singing of the Passion as part of the liturgy, without accompaniment and in neo-Gregorian manner. Schütz does not include any arias, and the only chorale occurs at the conclusion. What sounds comparatively dry by description is, however, enormously exciting and moving when heard in a performance that achieves the standard of vocalism heard in this recording. The performance of the individual soloists, whose diction is uncommonly clear, is highlighted by the beautifully expressive singing of Dietrich Fischer-Dieskau as the Evangelist, a performance that must rank as one of the baritone's greatest. The others interpret their parts with equal conviction and dramatic logic, and the fifty-three-voice chorus attains a lightness and transparency that is a joy to the ear. In spite of the necessarily limited appeal of the work, this exceptional performance, supremely well reproduced with unexaggerated church acoustics and correct liturgical placement of the voices in the stereo version, provides one of the best examples on records of Schütz at his greatest. For those who are curious about the various Fischer-Dieskaus participating in this recording, the conductor, Klaus, is the baritone's brother, and Lore is Klaus's wife. *I. K.*

**SHOSTAKOVICH:** *The Age of Gold* (see **BARTÓK**).

© ® **SHOSTAKOVICH:** *Symphony No. 5, Op. 47.* Minneapolis Symphony Orchestra, Stanislaw Skrowaczewski cond. MERCURY SR 90060 \$5.98, MG 50060\* \$4.98.

Interest: Mature Shostakovich  
Performance: Honorable  
(Continued on page 74)



DIETRICH FISCHER-DIESKAU  
*Profoundly moving artistry in the Schütz Passion*

technique of violin playing. His *L'arte del violino* consists of twelve violin concertos plus twenty-four *Capriccios* that were meant to be interpolated within the concertos. Vox, as part of a presumably complete Op. 3, has already issued the first four concertos in highly satisfactory performances (500500/2; 500/2), but in terms of smoothness of ensemble, virtuosic fiddle playing, and soaring intensity and warmth, the present recording is even more desirable. From every standpoint—performances and reproduction—this disc, beautifully recorded, should be considered one of I Musici's best, and it belongs in any library of Baroque music. *I. K.*

**MAHLER:** *Symphony No. 9* (see p. 55).

**MOZART:** *Symphony No. 39* (see **BEEHoven**).

in the more polished and equally vital performance recorded for Columbia by Eugene Ormandy and the Philadelphia Orchestra with the Rutgers University Choir. Without question, this is one of the best offerings yet on the low-price Parliament label. *D. H.*

**RACHMANINOFF:** *Ten Preludes* (see **BEETHOVEN**).

**SATIE:** *Trois Morceaux* (see **DEBUSSY**).

**SCHUBERT:** *Mass in E-flat* (see p. 52).

**SCHUMANN:** *Fantasia in C Major* (see **BEETHOVEN**).

#### RECORDING OF SPECIAL MERIT

© ® **SCHÜTZ:** *Historia des Leidens und Sterbens unsers Herrn und Hei-*



# Warren DeMotte's MUSIC QUIZ



1. MODEST Moussorgsky's *Pictures at an Exhibition* was inspired by paintings and drawings done by his friend Victor Hartmann. Name three other composers who have responded to graphic artists with musical works.

2. AMONG the signers of the Declaration of Independence was one of the infant nation's leading poet-composers. He played the harpsichord proficiently and wrote art songs. During the Revolutionary War, he composed satirical lyrics, and in 1781 he wrote *The Temple of Minerva*, a cantata celebrating the alliance with France. George Washington, the French minister, and other notables attended the premiere, which the composer conducted. Who was the patriot-composer?

3. THE USE of women singers to impersonate youths is an old tradition in opera. Can you name three such characters in the standard operatic repertoire?

4. LIGHTNING sometimes strikes twice. A famous composer's First Piano Concerto did not impress its dedicatee, so the dedication was transferred to a more receptive artist. Later, when the composer wrote a Violin Concerto, he dedicated it to Leopold Auer, who rewarded the compliment by ignoring the composition. Hurt, the composer rededicated the work to Adolf Brodsky, who played it at his Vienna debut, only to run afoul of a savage review by Eduard Hanslick in which he said that in the concerto "the violin was not played; it was beaten black and blue." Who was the composer?

5. ON SEVERAL occasions the identical story and characters have been used by more than one composer in their operas. However, in which of their operas did Mozart and Rossini set to music

different stories, both of which involve the same central character, although at different stages of his career? What is the name of that ubiquitous personage?

6. NEVER ONE to look far afield for inspiration, Haydn composed three of his earliest symphonies to the moods invoked by the simplest divisions of the waking day. Do you know which symphonies they are and what they are called?

7. THE HERO of Puccini's *Madama Butterfly* is hardly admirable, much less of heroic stature, but in his vocation he has much in common with the heroes of Wagner's *Der Fliegende Holländer*, Meyerbeer's *L'Africaine*, and Sullivan's *H.M.S. Pinafore*. What was the everyday occupation of these characters?

8. I KNOW of no *George Washington Symphony* or *Franklin Delano Roosevelt Symphony*, but Robert Russell Bennett has written an *Abraham*



*Lincoln Symphony* and Daniel Gregory Mason wrote a *Lincoln Symphony*. Can you recall two other contemporary compositions, written by the composers pictured above, bearing the name of the Great Emancipator?

9. BEFORE they became orchestra conductors, Leopold Stokowski was an organist and Eugene Ormandy was a violinist. Do you know what instruments the following conductors played before they took up the baton: Arturo Toscanini, Alfred Wallenstein, Hans Kindler, Daniel Saidenberg, and Sir John Barbirolli?

## ANSWERS:

1. Sergei Rachmaninoff: *The Isle of the Dead* (Arnold Böcklin), Enrique Granados: *Goyescas* (Francisco Goya). Harold Triggs: *Six Surrealist Afterludes* (Max Ernst, Francis Picabia, Salvador Dalí, Joan Miró, Giorgio de Chirico, Yves Tanguy). David Diamond: *World of Paul Klee* (Paul Klee). Gunther Schuller: *Seven Studies After Paul Klee* (Paul Klee). Paul Hindemith: *Mathis der Maler* (Matthias Grünewald).
2. Francis Hopkinson (1737-1791).
3. Octavian, in Richard Strauss's *Der Rosenkavalier*; Cherubino, in Mozart's *Le Nozze di Figaro*; Siebel, in Gounod's *Faust*.
4. Peter Ilyich Tchaikovsky.
5. Figaro appears in Mozart's *Le Nozze di Figaro* and in Rossini's *Il Barbiere di Siviglia*.
6. No. 6, in D Major, *Le Matin (Morning)*; No. 7, in C Major, *Le Midi (Noon)*; No. 8, in G Major, *Le Soir (Evening)*.
7. They were men of the sea.
8. Aaron Copland's *A Lincoln Portrait* and Morton Gould's *Lincoln Legend*.
9. They all played the cello.



Recording: Fine  
Stereo Quality: Mostly good

The Minneapolis Symphony's young conductor Skrowaczewski has tried an extremely interesting approach to the Shostakovich Fifth. The characteristics of his approach are precision, restraint, and, above all, meticulous clarity. The results are interesting—even admirable—but I am less sure that they are completely successful. Shostakovich's music, as a whole, is not too well served by revealing its technical substance and musical detail. Its primary effect lies in its sweep and grandiloquence. The less the listener is forced to concentrate on its musical substance, the more believable the composer's narrative. Mercury's recording is clear and rather reserved—an approach that suits the conductor's method quite perfectly. *W. F.*

**STRAVINSKY:** (see p. 76-77).

© ④ **WAGNER:** *Das Rheingold: Entry of the Gods into Valhalla. Die Walküre: The Ride of the Valkyries; Magic Fire Music. Die Götterdämmerung: Siegfried's Rhine Journey; Funeral Music.* Pittsburgh Symphony Orchestra, William Steinberg cond. COMMAND CC 11012SD \$5.98, CC 11012\* \$4.98.

Interest: Ring highlights  
Performance: Brilliant  
Recording: Impressive  
Stereo Quality: Likewise

As a Wagnerian stylist, Steinberg is one of the best around, as this recording eloquently proves. In both the *Rhine Journey* and the *Funeral Music* from *Die Götterdämmerung* he makes Wagner's romantic grandiosity wholly convincing and brings to fullest realization all the magical sonority of Wagner's magnificent orchestral fabric. The *Rhine Journey*, one of the Bayreuth master's happiest inspirations, gets the finest performance it has had on records since the great days of Arturo Toscanini. A substantial portion of credit for the effectiveness of this recorded performance belongs to the Command recording staff, which has done a beautiful job.

In many respects, the *Götterdämmerung* side of the disc is the most satisfying orchestral Wagner on disc. I only regret, however, that since Mr. Steinberg uses the Toscanini arrangement of the *Rhine Journey* introduction, he did not use Wagner's original ending instead of the synthetic Humperdinck version, thereby making possible a continuous transition into the somber grandeurs of the *Funeral Music*.

Such reservations as I have about this record concern the *Walküre* and *Rheingold* excerpts. With the exception of the high-speed *Ride of the Valkyries*, they

come under the heading of what the late Sir Donald Tovey used to call "bleeding chunks." The *Entry of the Gods*, which



WILLIAM STEINBERG  
*Wagnerian stylist par excellence*

is badly cut up here, suffers especially from this treatment. Nevertheless, half a disc of first-rate *Götterdämmerung* is better than none. *D. H.*

## COLLECTIONS

© ④ **DIETRICH FISCHER-DIESKAU:** *Opera Recital.* Bizet: *Carmen: Toreador Song; Les Pêcheurs de perles: L'orage s'est calmé . . . O Nadir tendre ami.* Gounod: *Faust: Avant de quitter ces lieux.* Verdi: *La forza del destino: Morir! tremenda cosa . . . Urna fatale; La Traviata: Di Provenza il mar.* Rossini: *William Tell: Resta immobile.* Giordano: *Andrea Chénier: Nemico della patria?* Leoncavallo: *Pagliacci: Si può?* Dietrich Fischer-Dieskau (baritone); Radio Symphony Orchestra, Berlin, Ferenc Fricsay cond. DEUTSCHE GRAMMOPHON SLPM 138700 \$6.98, LPM 18700 \$5.98.

Interest: Dieskau  
Performance: Disappointing  
Recording: Good average  
Stereo Quality: Good

This recital, calling for a fast-moving sequence of vivid dramatic images projected through effectively concentrated vocalism, exposes Fischer-Dieskau's vocal limitations in volume and range and his lack of interpretive authority in French

and Italian opera. For all his searching musicality, keen dramatic sense, and illuminative treatment of certain passages and phrases, he cannot make any of these arias wholly idiomatic and convincing. Unable to solve his musical problems by vocal means, he often resorts to undue emotional stresses. In the otherwise admirably flowing *Traviata* and *William Tell* arias he is defeated by the tessitura; in the dramatic monologues of *La forza* and *Pagliacci* his voice lacks richness and stylistic authority. Weakest of all is his *Toreador Song*; to begin the recital with this graceless and unrepresentative sample of the singer's art was a singularly unhappy choice.

Fricsay assures disciplined orchestral playing, but otherwise he, too, seems out of his element. DGG's surfaces are flawless; the sound has more liveliness and bite in stereo than in mono. *G. J.*

## RECORDING OF SPECIAL MERIT

④ **JOHN McCORMACK:** *Arias and Lieder.* Handel: *Atalanta: Come, beloved; Semle: Where'er you walk; Il Pastor Fido: Caro amor.* Mozart: *Ridente la calma (K. 152); To Chloë (K. 524).* Donaudy: *Luoghi sereni e cari; O del mio amato ben.* Pergolesi (?): *Tre giorni son che Nina.* Brahms: *Die Mainacht; In Waldeseinsamkeit.* Schubert: *Die Liebe hat gelogen.* Strauss: *Allerseelen.* Wolf: *Beherzigung; Ganymed; Auch kleine Dinge; Herr, was trägt; Schlafendes Jesukind.* John McCormack (tenor); Edwin Schneider and Gerald Moore (piano); orchestra, Walter Goehr cond. ANGEL COLH 123 \$5.98.

④ **JOHN McCORMACK:** *Songs and Ballads.* Quilter: *Now sleeps the crimson petal.* Foster: *Jeanie with the light brown hair; Sweetly she sleeps, my Alice fair.* Vaughan Williams: *Silent noon.* Haynes: *Off to Philadelphia.* O'Connor: *The old house;* and thirteen others. John McCormack (tenor); Edwin Schneider and Gerald Moore (piano). ANGEL COLH 124 \$5.98.

Interest: Unique artist  
Performance: Exceptional  
Recording: Good restoration

Supplementing the already available documentation of John McCormack's operatic, Irish, and sacred repertoire, these well-chosen recitals offer further evidence of this bygone artist's prodigious gifts. COLH 123 is evenly divided between classical arias and lieder. In the former, McCormack's purity of tone and exquisite legato are matched by a sovereign technique that makes the most exacting vocal problems sound easy. Since he never fully mastered the German *ö* and *ü* sounds, some will undoubtedly find his lieder quaintly inflected. Nonetheless, they are sung with impec-



cable clarity and with a wealth of illuminating nuance. Musical form and the purity of vocal line, the essence of McCormack's approach to singing, are never sacrificed to floodtides of emotion or overinterpretation. Yet, as his *Gany-med* eloquently proves, the emotional range of his singing was extraordinary.

His "Songs and Ballads" (COLH 124) reveal superlative vocal art lavished on material of slender musical significance. Here, again, the clarity of his enunciation is a thing of wonder. McCormack goes beyond the clear articulation of phrases, and even syllables—with him, even consonants are shaded with caressing attention. Now and then his instrument-like phrasing, his perfect sense of rubato, and those inimitable bell-like tones recall the art of his friend Fritz Kreisler. To imagine these two together again, making music as they did on countless occasions, is as comforting a view of heaven as any music lover could wish for.

The technical restoration on both discs is praiseworthy. Some surface noise is evident, but so is the characteristic, untampered-with timbre of John McCormack's voice.

G. J.

#### RECORDING OF SPECIAL MERIT

Ⓜ THE SILVER SWAN AND OTHER MASTERPIECES OF THE ELIZABETHAN AND JACOBAN MADRIGAL. Gibbons: *The Silver Swan; What is our life?; Ah! dear heart; Dainty fine bird.* Pilkington: *Rest, sweet nymphs; Diaphenia like the daffdown-dilly; Have I found her; O softly singing lute; Amyntas with his Phyllis fair.* Byrd: *Though Amaryllis dance; This sweet and merry month of May.* Ward: *Retire, my troubled soul; Upon a bank with roses; Out from the vale.* The Deller Consort (April Cantelo and Eileen McLoughlin, sopranos; Alfred Deller, countertenor; Wilfred Brown, tenor; Maurice Bevan, baritone). VANGUARD BACH GUILD BG 624 \$4.98.

Interest: Madrigal collection  
Performance: Excellent  
Recording: Warm and balanced

Some of the contents of this nicely varied collection are available in other recordings, Deller, in fact, having already made both the *Silver Swan* and *What is our life?* for DGG Archive with mostly the same performers, as well as the solo setting of *Rest, Sweet Nymphs* for Vanguard. Particularly interesting in the present performances is the style: very moving, sweetly sung, and with more warmth and sentiment than one is apt to hear. Most collections of this type feature an overly cool manner of madrigal singing, detached and devoid of emotion. For this reason, the disc at hand is well worth owning.

(Continued on page 78)

# SHERWOOD

only for those who want the ultimate

S-8000 FM/MX 64-watt Stereo Receiver \$299.00. 16¼" x 4½" x 14" deep. Combines Sherwood's brilliant FM stereo tuner design, two 32-watt amplifiers, two phono/tape pre-amplifiers, and all circuitry necessary to receive FM stereocasts.

RAVINIA Model SR3 3-way speaker system \$139.50. Walnut Cabinet 26¼" x 15" x 13¼" deep. 12" high-compliance woofer, 8" midrange, and 2½" ring-radiator tweeter. Features low intermodulation distortion, flat frequency response (± 2½ DB) to 17 KC.

S3000 IV FM/MX Stereo Tuner \$160.00. 14" x 4½" x 10½" deep. Identical tuner design to S-8000. Other tuners: S-2100 FM Stereo/AM Tuner \$199.50. S-2000 II FM/AM Tuner \$150.50. (Same but without FM stereo feature)

FM Stereo Multiplex Adapters may be used to convert Sherwood and other FM tuners for stereo-cast reception. \$49.50 to \$59.50.

S-5500 II 64-watt Stereo Pre-amplifier-Amplifier \$164.50. 14" x 4½" x 12¼" deep. Identical to amplifier used in S-8000. Other amplifiers: S-5000 II 80-watt Stereo Amplifier-Pre-amplifier \$199.50.



S-8000 FM/MX 64-watt Stereo Receiver



S3000 IV FM/MX Stereo Tuner



S-5500 II 64-watt Stereo Pre-amplifier-Amplifier

This typical room setting includes Sherwood's "Superb Stereo Starters,"—one S-8000 Receiver and two SR3 Loudspeakers. Sherwood Electronic Laboratories, Inc., 4300 N. California Ave., Chicago 18, Illinois.

Write for complete technical details.



Write Dept. R-7



# A BIRTHDAY PRESENT FOR STRAVINSKY

Honoring the occasion of Igor Stravinsky's eightieth birthday, Columbia Records has produced a five-disc salute to the modern master. Superb readings of *The Firebird*, *Le Rossignol*, and the *Symphony in Three Movements*—all conducted by Stravinsky himself—are the highlights.

by David Hall

## RECORDING OF SPECIAL MERIT

© ® STRAVINSKY: *The Firebird*. Columbia Symphony Orchestra, Igor Stravinsky cond. COLUMBIA MS 6328 \$5.98, ML 5728\* \$4.98.

Interest: The master's first masterpiece  
Performance: Warmly poetic  
Recording: Lovely  
Stereo Quality: Excellent

With this release of the complete *Firebird* ballet, Columbia now offers in stereo all three of the great dance masterpieces of Stravinsky's early maturity as conducted by their composer (the recent recordings of *Petrouchka* and *Le Sacre du printemps* are available on MS 6332/ML 5732 and MS 6319/ML 5719).

This, Stravinsky's first recorded performance of the complete *Firebird* score, seems to me superior to both the Ansermet-Suisse Romande version on London and the Dorati-London Symphony effort on Mercury. Ansermet captured the music's poetry but not its vigor, while Dorati gave us the vigor, but not much poetry, and in each instance the recorded sound tended to underscore the character of the performance in question. These performances made me feel *The Firebird* was more rewarding in the suite form usually heard in concert.

Stravinsky's own recording forces a reconsideration, and he accomplishes this by giving an interpretation that emphasizes proportion and poetry rather than dynamics and color. Thus, the pantomimic episodes no longer seem like dead spots between such famous highlights as the *Dance of the Firebird* and the *Infernal Dance of Kastehei's Subjects*.

Superlative orchestral playing and wonderfully warm-toned recording aid Stravinsky in this achievement. Indeed, a special bouquet goes to the first horn player, whose solo work embodies so flawlessly the inherent poetry and romantic Slavism in the music's best pages. Needless to say, this disc is indispensable Stravinsky.

## RECORDING OF SPECIAL MERIT

© ® STRAVINSKY: *Le Rossignol*. Loren Driscoll (tenor), The Fisherman; Reri Grist (soprano), The Nightingale; Marina Picassi (contralto), The Cook; Kenneth Smith (bass), The Chamber-

lain; Herbert Beattie (bass), The Bonze; Donald Gramm (bass), The Emperor; Elaine Bonazzi (mezzo-soprano), Death; chorus and orchestra of the Opera Society of Washington, D.C., Igor Stravinsky cond. COLUMBIA KS 6327 \$6.98, KL 5727\* \$5.98.

Interest: Poetic fairytale  
Performance: Feelingful  
Recording: Flawless  
Stereo Quality: Effective

Although its first act was composed prior to *The Firebird* and the remaining two were completed after *Le Sacre du printemps*, Stravinsky's brief opera after Hans Christian Andersen's *The Emperor and the Nightingale* remains one of the most satisfying and delightful of his early works. So engrossing are the poetry and grotesque comicality of the piece that its stylistic incongruities never intrude.

*The Firebird* is usually thought of as displaying the greatest influence of Stravinsky's teacher, Rimsky-Korsakoff; actually, however, the Korsakoffian influence seems far more evident in *Le Rossignol*—as do influences of Debussy—perhaps because the Chinese locale offers opportunities for the type of fantasy and glitter that we associate with Rimsky's *Golden Cockerel* or *Czar Saltan*.

At any rate, since the excellent French-language recording of *Le Rossignol* once available on Angel has been in the hard-to-get category for some years, it is a joy to have the score in a first stereo recording, sung in Russian, and conducted by Stravinsky himself, with a first-rate cast from the Washington Opera Society production of this past season.

The nostalgic, nocturnal song of the fisherman sets the atmosphere as the curtain rises; then the cascading roulades of the nightingale bring a feeling of expectancy. The comic element enters when the Chinese emperor's courtiers seek out the nightingale with the object of having her sing at court. As the nightingale assents, the act ends with the nostalgic song of the fisherman.

In the second act Stravinsky's post-*Sacre* music provides an extraordinarily original and riotous chinoiserie to pave the way for the entrance of the emperor and the nightingale's court aria. No sooner has this ended when three Japanese envoys enter with what they feel to be a far superior mechanical nightingale,

whose song Stravinsky characterizes with unerring craft. The true nightingale flies away at this point, and when the emperor discovers this, he banishes her and appoints the mechanical nightingale as court singer. Again the act ends with the fisherman's song.

The final act finds the emperor on his deathbed, and here the music takes on a mien of sinister pageantry. The true nightingale returns, and there ensues a strangely moving dialogue between Death and the nightingale. Death disappears, and the emperor begs the nightingale never to fly away again. As he falls asleep the court enters to begin the funeral ceremonies; but the emperor, restored to health by the nightingale's song, arises in full regalia with a morning greeting. The curtain falls as the fisherman is once more heard singing of the sunrise and the birds in the forest, through whose voices "the heavenly spirit himself does speak."

The poetry, humor, and drama of Stravinsky's music is superbly captured by all the vocal participants, notably by Reri Grist as the nightingale and by Donald Gramm, with a richly human portrayal of the emperor. The tricky choral parts in the opening of the court scene of the second act are stunningly managed by the Washington Opera Society forces. Stravinsky himself is in first-rate conductorial form, eliciting from his excellent orchestra beautifully accurate playing, full of zestful rhythm and vital phrasing. The stereo aspects of the recording are handled with taste, and the over-all sound is splendidly satisfying in its glitter of high-pitched percussion and weird string and brass sonorities.

*Le Rossignol* is one of Stravinsky's lesser-known scores, but it is as deserving of popularity as any of the three famous ballets—*Firebird*, *Petrouchka*, and *Le Sacre*—and we hope the present recording will help bring this to pass.

© ® STRAVINSKY: *Concerto for Piano and Wind Orchestra; Pulcinella Suite*. Seymour Lipkin (piano); New York Philharmonic, Leonard Bernstein cond. COLUMBIA MS 6329 \$5.98, ML 5729 \$4.98.

Interest: Stravinskian time-travel  
Performance: Spirited  
Recording: Good  
Stereo Quality: OK



The single orchestral disc in Columbia's mammoth release of music by Stravinsky that is not conducted by the composer finds Leonard Bernstein and the New York Philharmonic performing two works from the early stages of Stravinsky's stylistic journey away from his youthful rhythmic-kinetic Slavism toward cosmopolitan neo-classicism.

In *Pulcinella* (1919) Stravinsky probes directly into the heritage of eighteenth-century Italian music and transforms it into a *commedia dell'arte* ballet, Stravinskian in its kinetics and clear-cut so-

© ® STRAVINSKY: *Three Easy Pieces; Five Easy Pieces; Concerto for Two Solo Pianos; Sonata for Two Pianos*. Arthur Gold and Robert Fizdale (pianos). COLUMBIA MS 6333 \$5.98, ML 5733\* \$4.98.

Interest: Four-hand Stravinskiana  
Performance: Brilliant  
Recording: A bit tight  
Stereo Quality: Distinct separation

The two sets of Easy Pieces for piano four-hands (1915, 1917) are minor Stra-

the distinct stereo separation is a bit unrealistic; however, this effectively clarifies Stravinsky's rhythmic and contrapuntal textures.

© ® STRAVINSKY: *Violin Concerto; Symphony in Three Movements*. Isaac Stern (violin); Columbia Symphony Orchestra, Igor Stravinsky cond. COLUMBIA MS 6331 \$5.98, ML 5731\* \$4.98.

Interest: For the symphony  
Performance: Concerto good,  
symphony magnificent

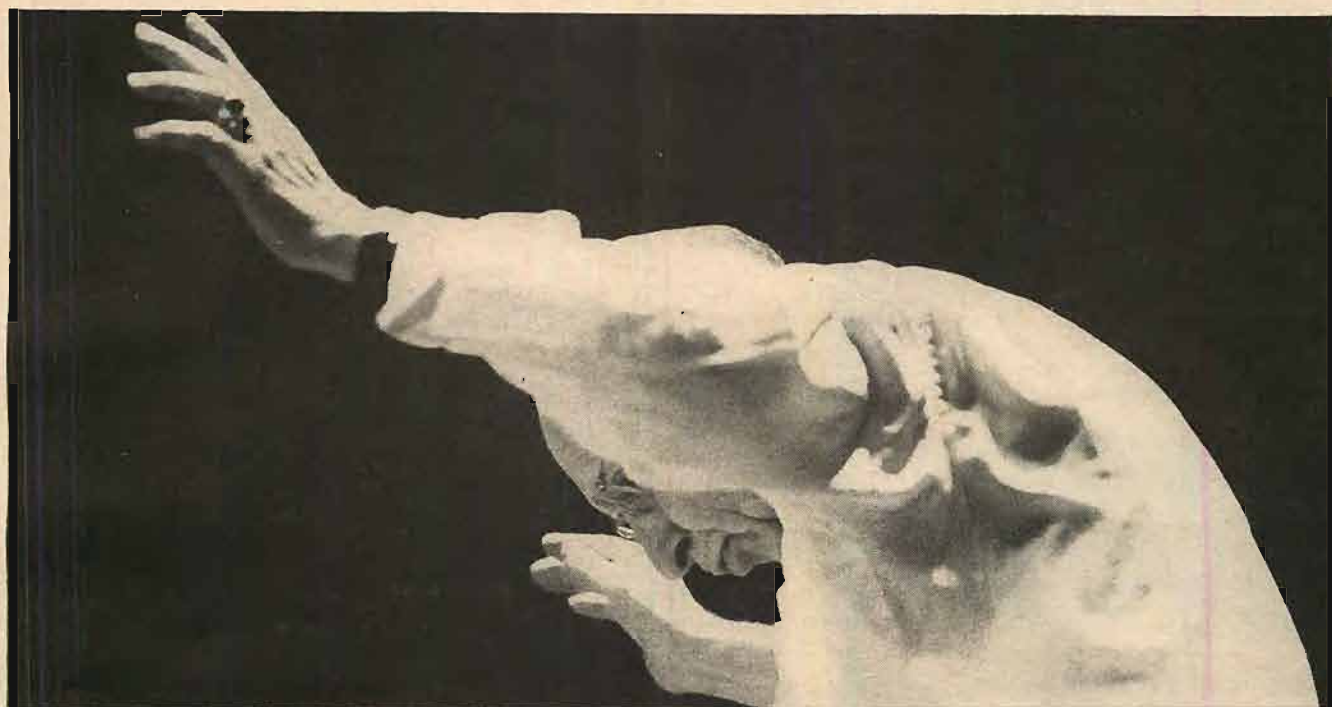

IGOR STRAVINSKY

*His conducting brings new warmth and poetry to his own music*

norities yet delightfully Italianate in spirit. Stravinsky's scoring is made to order for stereo, with its contrasts between solo string quintet, wind ensemble, and full string body. Bernstein leads a splendidly spirited performance, in which the fascinating Stravinsky rhythmic by-play gets its full due. However, the Italianate lyricism receives even more emphasis.

A more difficult piece for the listener is Stravinsky's Concerto for Piano and Wind Orchestra. Here the composer is launched upon a curious brand of back-to-Bachism, wherein he attempts to synthesize his own special rhythmic idiom with late-Baroque concerto procedure. Episodes of stately grandeur alternate with riveting-machine motorism and bits of jazzy syncopation. The musical high point of the concerto is the solemnly beautiful slow movement, alongside which the end movements sound contrived. Seymour Lipkin does an accurate and vital job with the solo part, and he is ably backed by Bernstein's conductorial support. The recorded sound is very good, indeed.

vinsky flirtations with the popular music-hall idiom that became fashionable among Parisian composers just after World War I. Stravinsky later arranged them for orchestra, and in either form the music makes for entertaining, if inconsequential, listening.

The Concerto for Two Pianos begins in Stravinsky's typical motoric neo-classic manner, proceeds to an exquisitely lyrical dialogue between the two pianos, and concludes with sharply contrasted variations and a grandiose prelude and fugue.

The Stravinskian neo-classic rigor is relaxed somewhat in the two-piano sonata. An easy flow characterizes the first movement, while elegant decoration of a simple and genuinely beautiful melody highlights the middle movement. Running polyphonic dialogue is the keynote of the finale.

Messrs. Gold and Fizdale have long been past masters in the realm of contemporary two-piano repertoire, and they are at their elegant and eloquent best throughout the two sides of this disc. The recorded sound is a trifle dry, and

Recording: First-rate  
Stereo Quality: Good

The Stravinsky Violin Concerto is one of those Stravinsky neo-classic stylings that can make its point only if both the solo and ensemble elements are brought off with the utmost brilliance and seemingly effortless ease. The least sign of laboring or unsureness and the whole thing falls to the ground. I recall a concert performance years ago by Zino Francescatti that made the concerto sound like a tour de force, but this recorded performance misses the mark—due to an inherent overrichness in Stern's tone that deprives the music of the necessary lightness.

The Symphony in Three Movements is something else again. I have long regarded it as the finest of Stravinsky's post-*Sacre* instrumental works—a brilliant synthesis of his neo-classic manner with kinetic dynamism à la *Sacre*. Stravinsky makes a thrilling experience of the end movements and an experience of loveliness of the slow movement. The orchestral execution is superlative, and the recorded sound is perfection.



# FM Stereo Kit Triumph

## knight-kit®

### STEREO FM MULTIPLEX ADAPTER KIT KS-10A

only \$1995

### SEND NO MONEY

only \$5 per month

enjoy beautiful Stereo FM reception at unbelievably low cost . . .

Now you can have the pleasure of an easy kit-building experience. Now you can add the tonal beauty and realism of Stereo FM broadcasts to your present music system. The savings simply can't be duplicated. The quality can't be matched for anywhere near the price. Order the KS-10A Knight-Kit Multiplex adapter today—no money down (just check coupon). Unbeatable value.



#### PROOF OF SUPERIOR VALUE

- Self-powered—installs out of sight • Separation control for precise stereo adjustment
- Frequency response 50-15,000 cps, ± 1 db
- Noise filter (switchable) for use in weak signal areas • Top-performing circuit using 2 dual and 1 triple-purpose tubes • Power supply is transformer-operated; uses selenium rectifier • Pi-filter network for ripple-free B+ voltage—hum is practically inaudible • Pre-aligned coils • AC on-off switch • Three 36" connecting cables included . . . Simply plugs into your tuner's Multiplex output and your amplifier's tuner inputs. With all connecting cables, tubes, parts, and famous Knight-Kit step-by-step instructions. 3 1/2 x 8 1/2 x 4". For 110-125 v. 60 cycle A.C. 4 lbs.

An amazing value at only . . . **\$1995**

Satisfaction guaranteed or your money back

## ALLIED RADIO KNIGHT ELECTRONICS DIVISION

**SEND NO MONEY**  
order today

**ALLIED RADIO**  
100 N. Western Ave.,  
Chicago 80, Ill.

Ship me the Knight-Kit Multiplex KS-10A Adapter Kit 83 Y 656 AV

Ship No Money Down on Allied's Credit Fund Plan

Name \_\_\_\_\_

Address \_\_\_\_\_

City \_\_\_\_\_ Zone \_\_\_\_\_ State \_\_\_\_\_

The sound, warm and balanced, matches the first-class performances. I. K.

© THE WORLD'S GREATEST MUSIC: Beethoven: *Symphony No. 3, in E-flat, Op. 55 ("Eroica")*. Czech Philharmonic Orchestra, Lovro von Maticac cond.; *Piano Concerto No. 5, in E-flat, Op. 73 ("Emperor")*. Frantisek Rauch (piano); Czech Philharmonic Orchestra, Karel Senja cond. Mozart: *Piano Concerto No. 21, in C Major (K. 467)*. Emil Gilels (piano); Moscow Chamber Orchestra, Rudolf Barshai cond. Mozart: *Violin Concerto No. 3, in G Major (K. 216)*. David Oistrakh (violin); Moscow Chamber Orchestra, Rudolf Barshai cond. Tchaikovsky: *Piano Concerto No. 1, in B-flat Minor, Op. 23*. Sviatoslav Richter (piano); Czech Philharmonic Orchestra, Karel Ančerl cond. Tchaikovsky: *Symphony No. 6, in B Minor, Op. 74 ("Pathétique")*. Czech Philharmonic Orchestra, Vaclav Talich cond. Dvořák: *Symphony No. 5, in E Minor, Op. 95 ("From the New World")*. Czech Philharmonic Orchestra, Vaclav Talich cond. Rimsky-Korsakoff: *Scheherazade, Op. 35*. Czech Philharmonic Orchestra, Zdenek Chalabala cond. Debussy: *La Mer*. Czech Philharmonic Orchestra, Roger Désormière cond. Borodin: *Prince Igor: Polovstian Dances*. Prague National Theater Chorus and Orchestra, Zdenek Chalabala cond. Moussorgsky: *A Night on Bald Mountain*. Czech Philharmonic Orchestra, Zdenek Chalabala cond. Tchaikovsky: *Overture 1812, Op. 49*. Prague Symphony Orchestra, Frantisek Stupka cond. Smetana: *The Bartered Bride: Overture*. Prague National Theater Orchestra, Jaroslav Vogel cond. Mendelssohn: *A Midsummer Night's Dream: Overture, Op. 21*. Vienna State Opera Orchestra, Hermann Scherchen cond. Brahms: *Tragic Overture, Op. 81*. Slovak Philharmonic Orchestra, Ladovit Rajter cond. Rachmaninoff: *Piano Concerto No. 2, in C Minor, Op. 18*. Sviatoslav Richter (piano), Leningrad Philharmonic Orchestra, Kurt Sanderling cond. PARLIAMENT WG M 1 ten 12-inch discs \$9.97.

Interest: Bargain classics  
Performance: Mostly good  
Recording: Mostly good

Anyone who is building a record library on a budget and seeks to get off to a flying start will find himself in luck with this remarkable ten-disc set from Parliament. Given the masterpieces recorded here, interpreted by such names as Richter, Oistrakh, Gilels, and Vaclav Talich, it is hard to see this set as anything less than a best buy.

The fact of the matter is that some of the major works, such as the Tchaikovsky "Pathétique," the Dvořák "New World," and the Beethoven "Eroica," hold their own in terms of performance

with any of the other competition in the Schwann catalog. Talich's Tchaikovsky and Dvořák is full of noble lyricism and drama, and Maticac's Beethoven is endowed with both power and dignity.

The Beethoven "Emperor" Concerto is a fine and conscientious reading, and the Mozart concertos, if not the last word stylistically, are done with fine vitality. Neither are the *Scheherazade* and *La Mer* the last word in polish, but they do have surge and zest. The Richter touch in the Tchaikovsky and Rachmaninoff concertos is unique in its sensitivity, though the recorded sound is somewhat uneven. The short pieces fare less well, with only the sparkling overture to *The Bartered Bride* and the rousing *Prince Igor* dances measuring up to the above-mentioned items in terms of performance and recorded sound. The Czech Philharmonic discs of the Tchaikovsky, Beethoven, and Dvořák symphonies have quite good sonics, and almost nothing else, save for the Brahms, Mendelssohn, and Tchaikovsky overtures, falls below acceptable standards. The surfaces are also generally decent. D. H.

© THE MAGNIFICENT SOUND OF THE PHILADELPHIA ORCHESTRA: Bizet: *Carmen Suite: Les Toreadors*. Liszt: *Hungarian Rhapsody No. 2*. Borodin: *Prince Igor: Polovstian Dance No. 2*. Tchaikovsky: *Sleeping Beauty: Waltz; Swan Lake; Waltz*. Bach: *Suite No. 3: Air; Toccata and Fugue, in D Minor*. Saint-Saëns: *Danse macabre*. Strauss: *Voices of Spring*. Grieg: *Peer Gynt Suite No. 1: Anitra's Dance*. Glinka: *Ruslan and Ludmilla: Overture*. Handel: *Water Music: Air*. Debussy: *Prelude to The Afternoon of a Faun*. Ravel: *Alborada del gracioso*. Sibelius: *The Swan of Tuonela*. Berlioz: *Symphonic Fantastique: March to the Scaffold*. Philadelphia Orchestra, Eugene Ormandy cond. COLUMBIA PHS 1 two 12-inch discs \$3.98, PHM 1 \$2.98.

Interest: Bargain hi-fi encores  
Performance: Philadelphian  
Recording: Brilliant  
Stereo Quality: Big spread

This assemblage of highlights from Columbia's huge catalog of Ormandy-Philadelphia Orchestra recordings is a first-rate value. In essence, it could be called "capsule classics for kicks," because both performances and recording, to say nothing of repertoire selection, are tailored for maximum sonic impact. Musical purists will cavil over the lush Bach and Handel, the racing Ravel, and the overemphatic Debussy and Sibelius. But no one can complain about the dazzling treatments of Saint-Saëns and Liszt or about the fine dash of Hungarian paprika with which Ormandy flavors the Strauss *Voices of Spring* waltz. This set is worth anybody's \$2.98 or \$3.98. D. H.



WITH THE death of Ruth Draper on December 30, 1956, the theater lost one of its most distinctive actresses and imaginative minds. For forty years Miss Draper had been performing monologues of her own invention and had won unanimous popular and critical acclaim. Her sketches, if that word does not slight the depth and incisiveness of her characterizations, ran a broad emotional range. She had a gift for recreating the speech cadences, the intonation, the vocabulary, and—most importantly—the innermost attitudes of a gallery of women as diverse as society grand dames, dozing mothers, selfish daughters, social secretaries, and social outcasts.

Ruth Draper was born to a socially prominent New York family and at an early age began doing little dramatic sketches for her family and friends. One family intimate, Ignace Paderewski, the pianist-statesman, suggested to her around 1910 that she do her monologues professionally.

Miss Draper began giving recitals in London's Aeolian Hall in 1920, appearing there for seasons of four to twelve weeks for more than twenty years. Tour followed tour, and honors heaped upon honors. She was painted in various roles by Sargent, appeared at a command performance at Windsor Castle, was made a Commander of the Order of the British Empire, and received many honorary degrees here and in Britain.

On the five Spoken Arts 799 series of discs called "The Art of Ruth Draper," each of which is priced at \$5.95, we have eleven examples of the unusual and demanding form of theater in which she worked. The set was recorded in January, 1954, only a few days before her passing, when Miss Draper was making what was called her farewell New York showing, at the Vanderbilt Theater.

It is gratifying to find how much of her art has been captured on these five recordings. While no record can evoke the excitement and anticipation one experiences in the theater, the very absence of a visual element allows the listener to conjure up the settings for himself. The mobility, clarity, and strength of Miss Draper's

voice was particularly suited to the phonograph.

Although Miss Draper once said that few of her monodramas (as she termed them) were drawn from actual experience, it is obvious that they were the result of sensitive observation in her wide travels. The *Italian Lesson*, the first selection on Volume 1, pokes some trenchant fun at a wealthy dilettante having a go at Dante. Everything intrudes on her bout with culture—telephone calls, menu-planning, children, telephone calls, plans to attend a not-too-grievous funeral, talks with maids and governesses, and more telephone calls.

## THE ART OF RUTH DRAPER by Robert Shelton



RUTH DRAPER  
*A genius for characterization*

The "student" speaks in a voice that is unctuous, pretentious, and arch, as refined and empty as its owner.

In *Three Generations in a Court of Domestic Relations*, also on Volume 1, Miss Draper portrays in turn a mother, grandmother, and daughter facing a rupture in their lives. If the daughter marries, the two older women must go to an institution. The conflict is movingly human, yet retold with amazing economy.

A master of dialects, Miss Draper in *The Scottish Immigrant*, which concludes the first disc, speaks with

believable humility and flavorsome Scotticisms of a young woman arriving in America to marry. Momentarily, the girl is afraid her intended will not arrive to claim her. Miss Draper's voice here assumes the modest, simple character of an honest girl on the brink of a new life, so hopeful, yet so fearful of the thread of one man's devotion on which it hangs.

*A Church in Italy* and *An English House Party*, which comprise Volume 2, have ample flashes of wit, balanced occasionally with a counterpoint of melancholy. There are moments in *A Church in Italy* when the gauche-ries of the tourist confronting Renaissance culture become at once laughable, yet almost uncomfortable.

Volume 3 begins with *The Children's Party*, which is a study in a mother's genial hysteria. *A Southern Girl at a Dance* is a broad take-off on a not-so-naïve young magnolia from below the Mason-Dixon line. And the actress does an incredible job of simulating Down East dialect in the *Maine Coast Village* episode.

The longest work here, a three-act melodrama, comprises Volume 4, *Three Women and Mr. Clifford*. Here is Miss Draper at her subtlest, revealing how deep ran her knowledge of women and men as well. With an almost Pirandello-like skill, she draws portraits of the three women in a wealthy executive's life: his amiable, efficient, worshipful secretary; his flinty, pampered wife, and his warm, compassionate mistress.

One side of Volume 5 is devoted to *The Actress*. This is more of Miss Draper's satire, and it cuts cleanly and hits bluntly at the same time. Miss Draper switches from heavily French-accented English to French to what apparently is Russian in a dazzling display of vocal control. *Doctors and Diets*, which is on the other side, is on a timeless, universal theme, centered on a group of dieting women at a fashionable restaurant.

The quiet, unassuming genius that made Ruth Draper an institution in the theater has been well served by these records. Since her repertoire numbered thirty-seven monodramas, it can only be hoped that more have been recorded for future release.



ahmad jamal  
 ramsey lewis trio  
 james moody  
 john young trio  
 jug ammons



AHMAD JAMAL LP 691

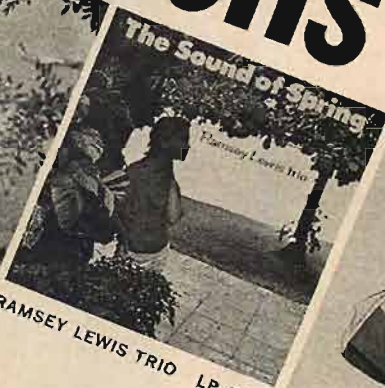

RAMSEY LEWIS TRIO LP 693



JAMES MOODY LP 695



JOHN YOUNG TRIO LP 692



JUG AMMONS LP 698

THE SOUNDS OF JAZZ  
 ON

**ARGO**

AVAILABLE OF COURSE, ON STEREO AT NO EXTRA CHARGE

**ARGO RECORDS**

2120 SOUTH MICHIGAN AVENUE, CHICAGO 11, ILLINOIS

CIRCLE NO. 5 ON READER SERVICE CARD

HIFI/STEREO REVIEW



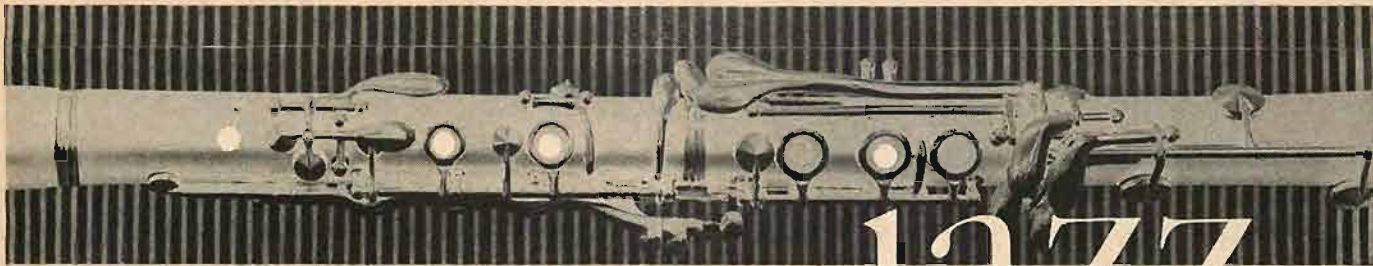

# Jazz

Reviewed by JOE GOLDBERG • NAT HENTOFF

### Explanation of symbols:

Ⓜ = monophonic recording

Ⓢ = stereophonic recording

\* = mono or stereo version  
not received for review

### RECORDING OF SPECIAL MERIT

Ⓢ Ⓜ BOB BROOKMEYER: *Gloomy Sunday and Other Bright Moments*. Bob Brookmeyer (valve trombone), Clark Terry (trumpet), Al Cohn (tenor saxophone), Hank Jones (piano). *Caravan; Why Are You Blue; Days Gone By; Oh My!; Some of My Best Friends; Detour Ahead; Where Oh Where; Ho Hum; Gloomy Sunday*. VERVE 68455\* \$5.98, 8455 \$4.98.

Interest: Arranger's showcase  
Performance: At times remarkable  
Recording: Good

Trombonist Bob Brookmeyer, best known as contributor to such tight-knit small groups as those of Gerry Mulligan, Stan Getz, and Jimmy Giuffrè, has been quietly getting better all the time. Here, he has assembled some of New York's top arrangers and musicians and has come up with an outstanding record.

It is an uneven album, made so by the fact that five different arrangers are involved. There is work that is average (Ralph Burns's *Caravan*), overelaborate (Brookmeyer's *Detour Ahead*), and charming (Brookmeyer's setting of Cole Porter's delightful and neglected *Where, Oh Where*). And there is fine solo playing, from Brookmeyer himself, and from such men as trumpeter Joe Newman and Phil Woods, who plays both alto and clarinet.

The album contains two tracks that would make it required listening even if it offered nothing else. First, there is Eddie Sauter's contrapuntal reworking of *Gloomy Sunday*, a brilliant short essay in organization, which features some of the best Brookmeyer work ever recorded. Then there is *Why Are You Blue*, composed and arranged by Gary McFarland, who is, with Oliver Nelson, one of the two young arrangers who have genuinely fresh ideas about big-band jazz. J. G.

Ⓢ Ⓜ AL COHN AND ZOOT SIMS: *Either Way*. Al Cohn (tenor saxophone), Zoot Sims (tenor saxophone), "Old Grand Happy" (piano), Bill Crow (bass), Gus Johnson (drums), Cecil "Kid Haffey" Collier (vocals). *P-Town; Autumn Leaves; Nagasaki; Morning Fun*; and four others. FRED MILES PRESENTS FM 1 \$4.98.

Interest: Sympathetic tenors  
Performance: Happy  
Recording: Good

Tenor saxophonists Al Cohn and Zoot Sims work better with one another than with anyone else. Here, with Bill Crow on bass and Gus Johnson on drums, and with a pseudonymous piano player who might be Mose Allison, they pursue what appears to be their mutual life's work: a lithe, deft evocation of the Lester Young-Count Basie era.

Both men are influenced by Young, and the casual listener is likely to have difficulty telling them apart. Probably Sims is the firmer, more inventive soloist, but when the two are working as well together as they are here there is little need to choose.

Three of the tracks feature ingratiating



BOB BROOKMEYER

*Fine soloing, variable arranging*

vocals by Cecil "Kid Haffey" Collier, who, appropriately enough, is reminiscent of the Basie era's Jimmy Rushing. Mention should be made of Bill Crow's fine solo on *P-Town*, while *Morning Fun* brings out the best in everyone. Fun without much depth probably best describes the set. J. G.

Ⓢ Ⓜ DUKE ELLINGTON: *All American* in Jazz. Duke Ellington (piano); orchestra. *Back to School; If I Were You; We Speak the Same Language*; and seven others. COLUMBIA CS 8590 \$4.98, CL 1790\* \$3.98.

Interest: Ducal wizardry  
Performance: Masterful  
Recording: Very good  
Stereo Quality: First-rate

The score for *All American*—by Lee Adams and Charlie Strouse—is both unpretentious and undistinctive. Accordingly, Duke Ellington's transmutation of this slight material into an experience of sustained musical interest reveals again his unique expertise and that of his collaborator, Billy Strayhorn.

The song treatments are graceful, flexible, and often slyly humorous. There are authoritative, careful solos by, among others, Lawrence Brown, Paul Gonsalves, Johnny Hodges, Ray Nance, Harry Carney, Jimmy Hamilton, and the uncredited Harold Baker on trumpet. An interesting footnote: Ellington's men saw the arrangements for the first time at the recording session. But being Ellington veterans they are not only quick readers but are swift to blend into a multi-colored instrument extremely sensitive to the subtlest desires of its manipulator, the perennially inventive Mr. Ellington.

N. H.

Ⓢ GRANT GREEN: *Grantstand*. Grant Green (guitar), Yusef Lateef (tenor saxophone and flute), Jack McDuff (organ), Al Harewood (drums). *Grantstand; My Funny Valentine; Blues in Maude's Flat; Old Folks*. BLUE NOTE 4086 \$4.98.

Interest: Basic blowing  
Performance: Committed  
Recording: Very good

Although this is nominally guitarist Grant Green's album, the main interest here is in the work of Yusef Lateef who limits himself to two of his many instruments, tenor saxophone and flute. On *Blues in Maude's Flat* his solo is little more than one quotation after another, but it fascinates by the sheer power of conviction with which it is played, as if



# The Barnes Library of Spoken Languages

idiomatic conversation recorded by native instructors of the foreign languages departments of Columbia University . . . 22 lessons . . . 2 different speeds—33½ rpm and 45 rpm. Each record in an attractive slip case accompanied with a foreign language conversational manual and a dictionary.



THE EASY WAY  
TO FRENCH  
\$3.95



THE EASY WAY  
TO SPANISH  
\$3.95



THE EASY WAY  
TO GERMAN  
\$3.95



THE EASY WAY  
TO ITALIAN  
\$3.95

COMBINED PACKAGE OF 4 LANGUAGE RECORDS  
only \$9.95

A. S. Barnes & Co. Inc.  
151-51 7th St.  
Whitestone 57, N.Y.

3AA

Please send me:

- EASY WAY TO FRENCH at \$3.95  
 EASY WAY TO SPANISH at \$3.95  
 EASY WAY TO GERMAN at \$3.95  
 EASY WAY TO ITALIAN at \$3.95  
 ALL FOUR RECORDS for only \$9.95  
 and/or

I enclose \$ \_\_\_\_\_  Send C.O.D.

NAME \_\_\_\_\_

ADDRESS \_\_\_\_\_

CITY \_\_\_\_\_ ZONE \_\_\_\_\_ STATE \_\_\_\_\_

Lateef were a modern Buddy Tate. On the overexposed *My Funny Valentine*, unexpectedly the triumph of the set, his flute is a thing of delicacy and beauty.

Green himself, like Lateef, combines simplicity and conviction into a compelling effect that has little to do with any quality of originality. Organist Jack McDuff is better suited to this kind of set than most; he mars one of the four numbers, *Grantstand*, but fits in admirably on the others. Drummer Al Harewood (there is no bassist) is quietly effective.

The record is a peacefully relaxed restatement of things everybody knows, but it is good to hear them said again by men who say them so well and believe in them so much. J. G.

© ® EDDIE HARRIS: *Jazz for "Breakfast at Tiffany's."* Eddie Harris (tenor saxophone); unidentified small combo. *Moon River; Hub Caps and Tail Lights; Latin Golightly;* and eight others. VEE JAY S-3027\* \$4.98, 3027 \$4.98.

Interest: Thin  
Performance: Routine  
Recording: Competent

© ® BARNEY KESSEL: *Breakfast at Tiffany's.* Barney Kessel (guitar), Victor Feldman (vibraphone), Paul Horn (alto saxophone; piccolo), Bud Shank (flute), Earl Palmer (drums). *Something for Cat; The Big Blow Out; The Big Heist;* and nine others. REPRISÉ R9 6019 \$4.98, R-6019\* \$3.98.

Interest: Audrey is missed  
Performance: Commercial  
Recording: Very good

Neither of these jazz versions of Henry Mancini's *Breakfast at Tiffany's* score are of more than passing interest. Eddie Harris, a tenor saxophonist with a light tone and pliable rhythmic sense, is fluent but limited in imaginative scope. His anonymous associates swing efficiently but are otherwise undistinguished.

Barney Kessel's approach on Reprise, employing somewhat more accomplished jazzmen, is aimed primarily at a pop audience. There is little in the basic material to stimulate the sidemen to contribute any unique conceptions of their own, even in the improvised solos. Mr. Mancini, as he has demonstrated in his own albums, is not a jazz composer, and it's a waste of jazz talent to devote two albums to what is largely background for acting. N. H.

## RECORDING OF SPECIAL MERIT

© ® JOHNNY HODGES: *Johnny Hodges, Soloist, Billy Strayhorn, and the Orchestra.* Johnny Hodges (alto saxophone); orchestra. *Gal from Joe's; Jeep's Blues; Stardust;* and eight others.

VERVE V6 8452\* \$5.98, V 8452 \$4.98.

Interest: Old pros  
Performance: Confident  
Recording: Excellent

Except for alumnus Quentin Jackson on trombone and pianist Jimmy Jones, this is the full Duke Ellington band. Since the principal soloist is their nightly associate and the arrangements are by Billy Strayhorn, the session is as relaxed as the last set of an Ellington dance in Omaha.

There are no surprises, no experiments. This is simply renewed proof of Johnny Hodges' total command of his instrument and his skill at effortless jazz lyricism. Most of the numbers, as Hodges points out in the notes, answer requests for vintage Hodges specialties, some of which are no longer in the active Ellington book.

In addition to Hodges' serene power, the session also underlines his consummate rhythmic accuracy. For Hodges' phrasing alone, the album will last as a definition of flowing swing. There are warm, unhurried solos by several of Mr. Hodges' associates, but the major secondary contribution is by trombonist Lawrence Brown, the equivalent of Hodges as an expert in supple romanticism. When I was a boy, the definitive jazz interpretation of *Stardust* was generally considered to be Jack Jenney's. Brown is featured on the same tune in this album, and Mr. Jenney has been eclipsed. N. H.

BILLIE HOLIDAY: *The Golden Years* (see p. 57).

© ® J. J. JOHNSON: *A Touch of Satin.* J. J. Johnson (trombone), Victor Feldman (piano), Sam Jones (bass), Louis Hayes (drums). *Satin Doll; Gigi; Bloozineff;* and six others. COLUMBIA CS 8537 \$4.98, CL 1737\* \$3.98.

Interest: Superb musicianship  
Performance: Uninvolved  
Recording: Excellent  
Stereo Quality: Good separation

J. J. Johnson is unquestionably one of the finest—if not *the* finest—modern jazz trombonists with unparalleled technical command of his instrument. Working with an excellent rhythm section, he fashions an effortless, faultlessly executed recital made up of standards, superior jazz pieces, a blues, and an original based on *What Is This Thing Called Love*.

Behind the superb taste, however, this music can almost be called impersonal, so little hint do we get of the man playing it. Even a piece as thorny and personal as Thelonious Monk's *Jackie-ing* evokes no response, nor does Gordon Jenkins' poignant *Goodbye*. There is slightly more involvement on the two muted numbers, *Gigi* (which has a bril-



liant unaccompanied entrance) and *Sophisticated Lady*, but never a hint of the man who has been playing so wonderfully with Miles Davis. The others acquit themselves well, although they are much more subdued than usual. The one exception is the raucous, exciting *When the Saints Go Marching In* that closes the set, as if Johnson had decided to take the wraps off just once before going home. As for the rest, there is considerably more than the touch of satin implied by the title, and that, although it may have been intentional, is also the trouble. J. G.

© ® **SHELLY MANNE:** *Shelly Manne and His Men Play "Checkmate."* Shelly Manne (drums), Conte Candoli (trumpet), Richie Kamuca (tenor saxophone), Russ Freeman (piano), Chuck Berghofer (bass). *Checkmate; En Passant; Fireside Eyes;* and four others. CONTEMPORARY S 7599 \$5.98, 7599\* \$4.98.

Interest: Slight  
Performance: Competent  
Recording: Excellent  
Stereo Quality: Fine

Shelly Manne's quintet devotes an entire LP to the music that pianist Johnny Williams wrote for TV's *Checkmate*. With the possible exception of *Fireside Eyes*, none of the pieces is likely to remain for long in the repertoire of this or any other band.

Drummer Manne says in the notes that he is attracted to the music's modal character: "With only a few changes, as in *Milestones* or Coltrane's *My Favorite Things*, the rhythm can create tension and mounting excitement through the use of ostinato effects." But, as in other instances when California musicians have belatedly attempted to assimilate the newer Eastern refinements, the impression is of craftsmen playing with more competence than conviction. Particularly embarrassing is Conte Candoli's slavish approximation of Miles Davis on *The Isolated Pawn*.

For this listener, the one virtue of the set is the brilliant work of an unfamiliar bassist, Chuck Berghofer. He and Manne take solos on the title track that are worth more than the rest of the disc. J. G.

© **DODO MARMAROSA:** *Dodo's Back!* Dodo Marmarosa (piano), Richard Evans (bass), Marshall Thompson (drums). *Mellow Mood; Cottage For Sale; Everything Happens To Me;* and seven others. ARGO 4012 \$3.98.

Interest: Rediscovered pianist  
Performance: Disappointing  
Recording: Good

Dodo Marmarosa achieved a considerable underground reputation primarily

through some original, technically brilliant solos he recorded with Charlie Parker more than a decade ago. Sadly, he is not the same personality on this record. Instead, we now have a pleasant, rather commonplace musician who cannot achieve several of the things he tries. There are some unusual choices here, such as *April Played the Fiddle* and *Me and My Shadow*, but they don't save this from being just another trio record.

It is not entirely a matter of the changes that have taken place in music since Marmarosa was at the peak of his powers, since these have never affected Teddy Wilson, for instance. There are occasional flashes of brilliance, but not enough to justify the LP. Lovers of Marmarosa's work are advised to play older records with the solos on which the reputation is based, and to avoid this set. J. G.



J. J. JOHNSON

*Emotion subordinated to polish*

© **HANK MOBLEY:** *Workout.* Hank Mobley (tenor saxophone), Grant Green (guitar), Wynton Kelly (piano), Paul Chambers (bass), Philly Joe Jones (drums). *Uh Huh; Smokin'; Greasin' Easy;* and two others. BLUE NOTE 4080 \$4.98.

Interest: Rhythm section pre-eminent  
Performance: Energetic  
Recording: Excellent

Hank Mobley, a member of Miles Davis' unit when he is not recording albums under his own name, has all the elements of jazz professionalism. He phrases intelligently, swings easily, and has a warm sound of his own. Unfortunately, he is rarely exciting either in terms of his ideas or in his capacity to plumb the more basic emotions.

In this session, for example, Mobley is much less interesting than his supporting

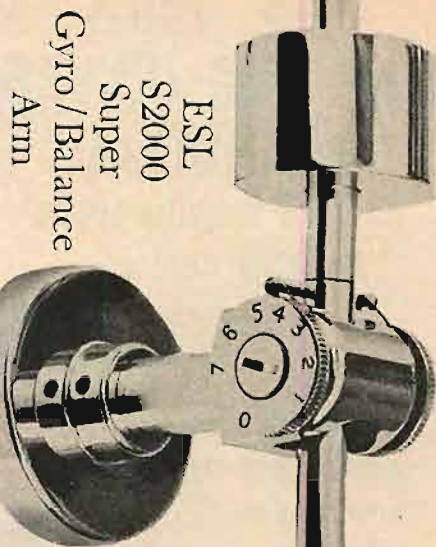

ESL  
S2000  
Super  
Gyro/Balance  
Arm

BEST ARM FOR  
YOUR HI-FI SYSTEM

Buy it at your dealers  
today, only \$34.95



FOR LISTENING AT ITS BEST  
Electro-Sonic Laboratories, Inc.  
DEPT. R, 627 BROADWAY, NEW YORK 12, N. Y.

CIRCLE NO. 17 ON READER SERVICE CARD



# THE 1962 CAR AND DRIVER YEARBOOK

is your buying guide  
to 250 new cars

... and an  
indispensable  
compendium  
of information  
on cars!



Here's the one place you can compare the 250 foreign and domestic cars on the market today! The 1962 CAR AND DRIVER YEARBOOK has 144 pages of information on all the newest models—complete with pictures of each car, price, performance data and specifications.

Get exclusive features like these in the 1962 CAR AND DRIVER YEARBOOK:

- Road Research Reports on 8 top cars by the editors of CAR AND DRIVER
- Survey of technical developments
- Listing of all importers of cars in the U.S.—complete with addresses
- A backward look at the 1961 racing season
- Gallery of the world's famous drivers plus origins of all cars currently in production
- "OPINION AND FORECAST"—a consensus based upon interviews with top executives in the automotive industry and in government

The 1962 CAR AND DRIVER YEARBOOK is now on sale. Get your copy today at your favorite newsstand. Or send in this coupon and we will mail your copy. **Only \$1.00**

Retail Sales Division  
Ziff-Davis Publishing Co.—Dept. BT  
One Park Avenue  
New York 16, New York

Please send me a copy of the new 1962 CAR AND DRIVER YEARBOOK. I enclose \$1.00, the cost of the YEARBOOK, plus 10c to cover mailing and handling charges. (Canada and Foreign, \$1.25 plus 10c postage.)

Name \_\_\_\_\_

Address \_\_\_\_\_

City \_\_\_\_\_ Zone \_\_\_\_\_ State \_\_\_\_\_

(add 3% sales tax if New York City resident)

HF-72

cast, which constitutes a model modern jazz rhythm section. Kelly, Jones, and Chambers have worked together with Miles Davis (Chambers and Kelly are still with the trumpeter), and they achieve an invigorating, perfectly balanced coordination that could lift the most mediocre soloist to new rhythmic accomplishments. Each, moreover, is a superb soloist. The addition of guitarist Grant Green—a mellow, straightforward swinger—adds further depth and joy to the section. In fact, if the leader had been absent this would have been an outstanding album. As it presently stands, the sidemen make it very good indeed.

N. H.

⑤ ④ **TURK MURPHY:** *Let The Good Times Roll.* Turk Murphy (trombone), Ernie Carson (cornet), Bob Helm (clarinet and soprano saxophone), Pete Clute (piano and calliope), Bob Short (tuba), Frankie Capp (drums), Pat Yankee (vocals). *Lonesome Road; Tiger Rag; Tin Roof Blues;* and eight others. RCA Victor LSP 2501 \$4.98, LPM 2501\* \$3.98.

Interest: Good-time jazz  
Performance: Spirited  
Recording: Very good  
Stereo Quality: Good

It is difficult to be at all critical of an album like this, for, despite all the scrupulous Turk Murphy scholarship made so much of in the notes, what emerges is sheer fun.

Murphy leads the most successful of the revivalist bands, and he has been one of the leading figures around which the controversial attempt to resuscitate New Orleans music has centered. In some instances, as in his arrangement for Louis Armstrong of *Mack the Knife*, he has been enormously successful. Here, he applies the same approach to eleven tunes of varying origin, and will probably have another Kurt Weill hit with *Bilbao Song* in a version that includes calliope. The major soloist is clarinetist Bob Helm, and vocalist Pat Yankee is admirably suited to the proceedings. I doubt that even Murphy takes any of this too seriously, but it is wonderful music for beer parties or college weekends.

J. G.

## RECORDING OF SPECIAL MERIT

⑤ ④ **ART PEPPER:** "*Smack Up.*" Art Pepper (alto saxophone), Jack Sheldon (trumpet), Pete Jolly (piano), Jimmy Bond (bass), Frank Butler (drums). *A Bit of Basie; Maybe Next Year; Tears Inside;* and three others. CONTEMPORARY S 7602 \$5.98, 3602\* \$4.98.

Interest: Major jazz altoist  
Performance: Brilliant  
Recording: First-rate  
Stereo Quality: Excellent

Because of personal difficulties, Art Pepper has had a ragged career. Yet his reputation has survived his long periods of absence from jazz, and this album—recorded in October, 1960—further demonstrates why Pepper's contribution has proved so durable. He plays, first of all, with an exceptionally fertile melodic imagination as well as a powerful, brawny tone. His time is both accurate and elastic.

For this collection, Pepper has chosen originals written by saxophonists, including his own sinuous *La Cuevas de Mario*. Particularly worth reviving are Duane Tatro's haunting *Maybe Next Year*, and *How Can You Lose*, a casual, provocatively wistful theme by Benny Carter.

Jack Sheldon plays a spare, introspective horn and is capable of a surprising range of dynamics. Pete Jolly, a maturing pianist, is crisply ebullient, and bassist Jimmy Bond is a firm anchor. Frank Butler continues to impress this listener as the most incisive and resourceful drummer on the West Coast.

The recorded sound is faultless, and the balance brings the rhythm section into clear relief while simultaneously fitting the horns into the framework with just the right sense of aural proportion. N. H.

⑤ **ANDRÉ PREVIN AND J. J. JOHNSON:** *Play Kurt Weill.* André Previn (piano), J. J. Johnson (trombone), Red Mitchell (bass), Frank Capp (drums). *Bilbao Song; Wie man sich bettet; Mack The Knife;* and five others. COLUMBIA CS 8541 \$4.98, CL 1741\* \$3.98.

Interest: Weill in modern jazz  
Performance: Intriguing  
Recording: Warm and clear  
Stereo Quality: Good

André Previn's first recording with J. J. Johnson succeeds because of the acumen of Columbia producer, Irving Townsend, who challenged the co-leaders with eight Kurt Weill pieces from *The Threepenny Opera, Happy End, and Mahagonny*. Most have not previously been interpreted in the modern jazz manner.

Previn is a cosmopolitan conversant with a wide range of musical disciplines. He obviously has temperamental affinity with Weill's similarly heterogeneous background and tastes, including Weill's tartness and his penchant for sardonic surprises. Johnson, who is an ironist, has often seemed only partially absorbed in the usual jazz numbers he plays. Weill's pungent material, however, has drawn him out, and he clearly relishes the chance to explore textural and rhythmic means of personalizing the composer's nostalgia and biting wit.

I would have preferred one or two more horns to provide additional density and variety of color. Drummer Frank Capp is unobtrusively capable, and bass-



ist Red Mitchell is excellent. N. H.

Ⓜ **IKE QUEBEC:** *Heavy Soul*. Ike Quebec (tenor saxophone), Freddie Roach (organ), Milt Hinton (bass), Al Harewood (drums). *Acquitted; The Man I Love; Heavy Soul*; and five others. BLUE NOTE 4093 \$4.98.

Interest: Return of a tenorman  
Performance: Impassioned  
Recording: Very good

Tenor saxophonist Ike Quebec, who had a considerable reputation in the Forties, has been only intermittently active since then. Quebec is a powerful saxophonist who alternates between movingly direct passages and restatements of clichés. The choice of such unusual material as *Brother, Can You Spare A Dime* and *I Want A Little Girl* is rare and welcome, as is a remarkable, moody version of *Nature Boy*, accompanied only by Milt Hinton's bass. On all other tracks, Quebec, in current style, has the services of an organist. The disc will appeal greatly to those who are fond of Gene Ammons' ballad style. As with Ammons, there are many hints of Lester Young.

Within the limitations of the Ammons-with-organ approach, this is a very good record, and there is some excellent saxophone playing on it. It is only a shame that Quebec had nothing more original to offer on his first LP. J. G.

SONNY ROLLINS: *The Bridge* (see p. 58).

Ⓜ Ⓜ **MARY STALLINGS AND CAL TJADER:** *Mary Stallings—Sings; Cal Tjader—Plays*. Mary Stallings (vocals), Cal Tjader (vibraphone), Lonnie Hewitt or Clare Fischer (piano), Freddie Schreiber or Victor Venegas (bass), Johnny Rae (drums), Paul Horn (flute). *Goodbye; Mr. Blues*; and ten others. FANTASY 8068\* \$4.98, 3325 \$3.98.

Interest: New singer  
Performance: Promising  
Recording: Poor

This is the recording debut of Mary Stallings, a twenty-two-year-old singer from San Francisco. She has a lot of things going for her: a strong, supple voice; an appealingly brash, youthful cockiness; and a true feeling for the blues and the church backgrounds of jazz singing. She has chosen some excellent material such as Billie Holiday's *God Bless the Child*, four Ellington tunes, two by Fats Waller, and others.

The main drawback is the accompaniment, played by a small group led by Cal Tjader. The band is too underrecorded for support, and the musicians seem to be striving to simulate the feelings that come naturally to Miss Stallings. J. G.



**CLIP!  
it's on...**

**WOOSH  
...dust's gone!**

...using the ALL NEW Changer Model Dust Bug®!

- ★ The Dust Bug cleans records thoroughly and safely
- ★ Designed to fit all high fidelity record changers
- ★ Reduces surface noise, ends stylus fuzz
- ★ No vertical stylus loading on cartridge

Turntable owners—Buy the Standard Dust Bug—over  
200,000 Sold—\$5.75

CHANGER MODEL  
DUST BUG  
**\$4.75**  
COMPLETE

**ESL** FOR LISTENING AT ITS BEST  
**Electro-Sonic Laboratories, Inc.**  
DEPT. R, 627 BROADWAY, NEW YORK 12, N. Y.

CIRCLE NO. 17 ON READER SERVICE CARD

**DESIGN for MUSIC!**

**LAFAYETTE ELIPTOFLEX SPEAKER SYSTEMS**

Newly Designed Elliptical Port  
Specially Engineered Diffracting Ring.

**LAFAYETTE ELIPTOFLEX With SK-180 10" TRIHELIX 3-WAY SPEAKER**  
6650

**LAFAYETTE ELIPTOFLEX With SK-210 12" 3-WAY SPEAKER**  
8250

Eliptoflex—a bookshelf speaker delivering a degree of natural smoothness, presence, low distortion and rich robust bass normally associated with large enclosure speaker systems. Developed by the Lafayette High-Fidelity Research Laboratories, the Eliptoflex utilizes a unique elliptical port to extend frequency and transient response. A specially engineered diffracting ring eliminates cancellation effects between front and rear radiation. Finished on 4 sides in your choice of walnut, oiled walnut, mahogany or blond.

**FREE!**  
LAFAYETTE RADIO SUMMER CATALOG SUPPLEMENT

LAFAYETTE RADIO, Dept. HMG-2, BOX 10, Syosset, L.I., N.Y.

Name \_\_\_\_\_  
Address \_\_\_\_\_  
City \_\_\_\_\_ Zone \_\_\_\_\_ State \_\_\_\_\_

Eliptoflex with SK-180 Finish  
 Eliptoflex with SK-210 Finish  
\$ \_\_\_\_\_ Enclosed  
 Free Catalog

**LAFAYETTE RADIO**  
NEW MAIL ORDER AND SALES CENTER.  
SYOSSET, LONG ISLAND, N. Y.

OTHER LOCATIONS JAMAICA 33, N. Y.  
NEW YORK 13, N. Y. BRONX 58, N. Y. NEWARK 2, N. J.  
PLAINFIELD, N. J. PARAMUS, N. J. BOSTON 10, MASS.

CIRCLE NO. 27 ON READER SERVICE CARD



# reel & cartridge

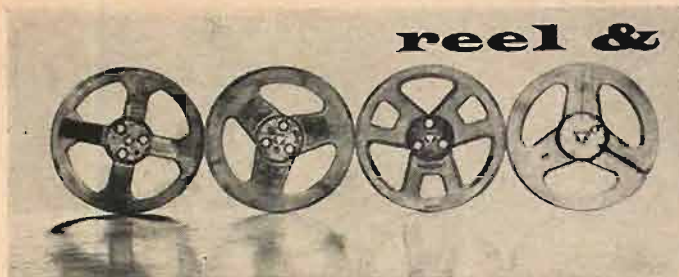

● CHRISTIE BARTER  
● DAVID HALL

### Explanation of symbols:

- Ⓜ = monophonic recording
- Ⓢ = stereophonic recording

## 4-TRACK CLASSICS

Ⓢ **BACH: Brandenburg Concertos (complete).** Members of the Vienna State Opera Orchestra, Hermann Scherchen cond. WESTMINSTER WTT 151 two reels \$17.95.

Interest: Brandenburg bow on tape  
Performance: Idiomatic  
Recording: Fine  
Stereo Quality: Adequately directional

One of the best recordings of the Brandenburgs is the first to arrive on tape. Rerecorded recently for stereo, Scherchen's performances are intimate, his phrasing supple, his tempos, where they depart from the norm, on the slow side. An outstanding solo contributor is harpsichordist George Malcolm in the fifth concerto. The first four are contained on one of the two reels, meaning that anyone interested in listening only to the fourth will have to do some fancy fast-forwarding to get to it. (The fourth, incidentally, uses recorders, nicely played by Paul Angerer and Karl Trötzlmüller). The fifth and sixth Brandenburgs share the second reel, one each to a side. The sound, overall, is clean. Stereo distribution is good, and the recorded level is gratifyingly high. Scherchen's chamber ensemble is comfortably present, and individual members are easily located. C. B.

### RECORDING OF SPECIAL MERIT

Ⓢ **BEETHOVEN: Symphony No. 9, in D Minor, Op. 125 ("Choral"); Symphony No. 1, in C Major, Op. 21.** Phyllis Curtin (soprano), Florence Kopleff (contralto), John McCollum (tenor), Donald Gramm (bass). Chicago Symphony Orchestra and Chorus, Fritz Reiner cond. RCA VICTOR FTC 3005 \$10.95.

Interest: Reiner's only Ninth  
Performance: Granitic  
Recording: Magnificent  
Stereo Quality: Just right

Of the three recordings of Beethoven's

Ninth Symphony now on tape, this one is easily the best. Although Reiner has conducted the Ninth many times, this is his first recording of it, and the wait has been altogether worthwhile. His performance has not only the expected authority, but discloses the utmost penetration of the score's substance and a unified grasp of its epic scope that only years of study and preparation can yield. The Chicago Symphony, too, has never sounded better, and the soloists and chorus are absolutely first-rate. The sound is transparent, radiantly full-bodied, and vibrant, transferred to tape at just the right dynamic level. Stereo directionality is pronounced but superbly balanced.

The notes provided with the package are skimpy, but the booklet bound into the disc edition may be sent for. C. B.

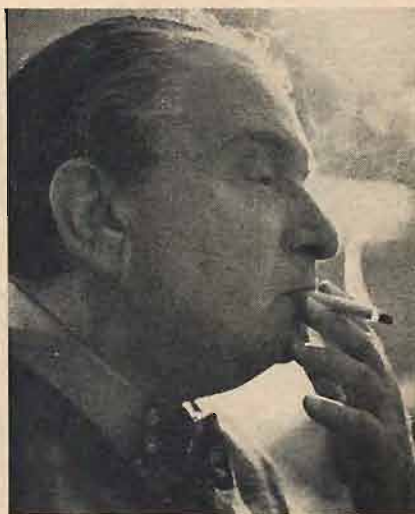

FRITZ REINER

*The best Beethoven's Ninth on tape*

Ⓢ **DEBUSSY: Images pour Orchestre (Gigues; Ibéria; Rondes de Printemps).** STRAVINSKY: *Symphonies for Wind Instruments.* RAVEL: *Pavane pour une Infante défunte.* Suisse Romande Orchestra, Ernest Ansermet cond. LONDON LCL 80085 \$7.95.

Interest: Mostly for Debussy  
Performance: Polished  
Recording: OK  
Stereo Quality: Ditto

Ansermet's rerecordings of the French repertoire for stereo disclose steadily growing self-awareness of his role as interpreter of this music. As unusual as it is for a conductor to subject the Debussy

or Ravel scores to the same interpretive scrutiny most pianists bring to the keyboard literature of these same composers, Ansermet is doing just that. His readings of the Debussy *Images* appear to get to the very soul of the music. Surface color, while amply projected by this warm and luminous recording, is only incidental to the poetry these performances evoke. The move to the machine-like metrics and lean textures of Stravinsky's *Symphonies for Wind Instruments* comes as a bit of a jolt by comparison. The notes explain their presence on this reel: "The work is dedicated to the memory of Debussy and was first offered as the Russian composer's contribution to a special 1920 issue of the *Revue Musicale*, published to honor Debussy." The revised version of 1947 was first performed in 1948 by the NBC Symphony under Ansermet's direction. The sound is silken, somewhat lacking in sharp brilliance but nicely balanced. Dynamic level could have been higher. C. B.

Ⓢ **HANDEL: Water Music, Suite; Royal Fireworks Music, Suite; The Faithful Shepherd (arr. Beecham); Minuet; Xerxes: Largo.** London Symphony, George Szell cond. LONDON LCL 80089 \$7.95.

Interest: Handelian staples  
Performance: Handsome  
Recording: Excellent  
Stereo Quality: Good depth

It is strange that two such popular suites should be represented by only one other tape recording. Szell's, the first on tape by a major conductor, is magnificent. In both the *Water Music* and the *Royal Fireworks Music* he delivers well-groomed, impeccably controlled performances. The orchestral sound is warm and full, yet crystalline throughout. Dynamic level is high, and stereo perspectives are just what they should be for utmost realism. C. B.

Ⓢ **LOLLIPOPS AUS WIEN: Johann Strauss, Sr.: Gitana Galopp; Annen Polka; Hofball-Tänze; Seufzer Galopp. Mayer: Schnoffer Tanz. Haydn: Zingarese; Katherinen-Tänze. Schubert: Dances from Op. 9; Ecossaises, Op. 49. Lanner: Abendsterner Walzer; Stelzmüller: Stelzmüller-Tanz. Boskovsky Ensemble, Willi Boskovsky cond. VANGUARD VTC 1639 \$7.95.**



Interest: Viennese confections  
 Performance: Spirited  
 Recording: Transparent  
 Stereo Quality: Adequate

Willi Boskovsky, the Vienna Philharmonic's concertmaster, and his salon-sized first-desk ensemble again play an informal set of galops, waltzes, and other dances of Alt Wien for the delectation of music lovers everywhere. A sequel to their equally delightful "Bonbons aus Wien" (Vanguard VTC 1634), this reel contains airy dances by Schubert and by the elder Strauss, some robust gypsy music by Haydn, and bright little pieces by composers all but forgotten now—all performed in their original scoring for no more than eight musicians. (The Mayer and Stelzmüller dances are played by two violins with guitar, and they sound marvelous.) The luster of their playing is mirrored by the life-like recording, technically a first-rate job. *C. B.*

© VERDI: *Aida*. Leontyne Price (soprano), Aida; Rita Gorr (mezzo-soprano), Amneris; Jon Vickers (tenor), Radames; Robert Merrill (baritone), Amonasro; Giorgio Tozzi (bass), Ramfis; Plinio Clabassi (bass), The King of Egypt; Franco Ricciardi (tenor), Messenger; Mietta Sighele (soprano), Priestess. Rome Opera House Orchestra and Chorus, Georg Solti cond. RCA Victor FTC 8005 two reels \$21.95.

Interest: Mostly for Leontyne  
 Performance: Large-scaled  
 Recording: Excellent  
 Stereo Quality: Highly directional

The interest here is Leontyne Price's portrayal of Aida, vocally resplendent and unmatched on any opera stage today. It must be compared, though, with the other Aida on tape, the Aida sung by Renata Tebaldi for London (LOR 90015). Mme Tebaldi makes a flesh-and-blood creation of the ill-fated Ethiopian princess and conveys a deep sense of personal tragedy that Miss Price does not. Note as early as "Ritorna vincitor" the bitterness Mme Tebaldi imparts to the lines. For all its intensity, heroic proportion, and unerring musicianship, Miss Price's Aida lacks these refinements of characterization—at least, at this time, and in this recording.

The greatest disappointment in the Victor tape is the Radames of Jon Vickers. Temperamentally the role may be right for him, but musically it is not. Even the Italian language gives him some difficulty. Tozzi and Merrill, on the other hand, are superb, the latter especially. Solti's tempos are somewhat tighter than Karajan's, his direction earthier.

The recorded sound is magnificent, surpassing even London's in dynamic vigor, clarity of detail, and stereo dis-

tribution. The Triumphal Scene, filled out with numerous extras, bringing the total personnel to three hundred, is overwhelming. Besides the absence of distortion in climactic scenes such as this, the tape has the advantage of allowing each of the four acts to play through without interruption. No libretto is supplied, but it may be obtained from RCA Victor at no charge. *C. B.*

© VERDI: *Un Ballo in Maschera*. Birgit Nilsson (soprano), Amelia; Carlo Bergonzi (tenor), Riccardo; Cornell MacNeil (baritone), Renato; Giulietta Simionato (mezzo-soprano), Ulrica; Sylvia Stahlman (soprano), Oscar; Fernando Corena (bass), Samuel; Libero

Arbace (bass), Tom; Tom Krause (baritone), Silvano. Chorus and Orchestra of L'Accademia di Santa Cecilia, Rome, Georg Solti cond. LONDON LOG 90039 two reels \$19.95.

Interest: Journeyman Verdi  
 Performance: Good but uneven  
 Recording: Unbalanced  
 Stereo Quality: Excellent

A less than supreme *Ballo*, which this one clearly is, is better than none. It is the first on tape but must be received with qualified enthusiasm, mostly because the casting and certain aspects of the engineering show some lack of judgment. All three of the principals sing well and, by

## Double your Listening Pleasure with

REVERSE-O-MATIC®

NEW... from the  
 leader in quality  
 recording equipment

# Concertone

## S505

### Stereo Recorder



This new, deluxe version of the famous Concertone 505... in gleaming brushed stainless steel... will meet your most exacting demands for reproduction of professional quality. Its exclusive playback feature, Concertone's REVERSE-O-MATIC, plays 4-track stereo tapes from start to finish, reverses, then plays the other stereo tracks... automatically! It doubles listening pleasure and unattended playing time *with no changing of reels*. Concertone's new Model S505 plays 4-track, records qtr. track stereo and monaural. Priced from \$599.50. Other stereo models of the famous Concertone 505 recorders are priced from \$549.50.

See your Concertone dealer for a demonstration of the S505 with Reverse-O-Matic, or write today for a brochure which shows complete details on the magnificent recorder that doubles your listening pleasure with professional quality.



AMERICAN CONCERTONE, INC.  
 A DIVISION OF ASTRO-SCIENCE CORPORATION  
 9449 WEST JEFFERSON BOULEVARD • CULVER CITY, CALIFORNIA

Dealer inquiries invited. EXPORT: Telesco International Corp.,  
 171 Madison Ave., New York 16, N.Y.

CIRCLE NO. 3 ON READER SERVICE CARD



themselves, are more or less suited to their roles. Their characterizations remain pallid, but the real trouble lies in the balances of voice to voice. Birgit Nilsson's vocally opulent Amelia puts Carlo Bergonzi's Riccardo at some aural disadvantage. Bergonzi and MacNeil, besides, have far more agile voices, and in the Act II trio Mme Nilsson only seems to be holding them down. The performance rarely gets off the ground, despite the occasional excitement generated by Georg Solti's direction. The orchestral work on this recording is brilliant but engineered into an all-too-prominent role. The sound is otherwise very good, although there is some print-through and a fair amount of tape hiss. It seems a pity that the first act has to be interrupted only four minutes before its conclusion. No libretto is supplied, but it can be obtained from London Records.

C. B.

© **VERDI: *Otello***. Mario del Monaco (tenor), Otello; Renata Tebaldi (soprano), Desdemona; Aldo Protti (baritone), Iago; Ana Raquel Satre (mezzo-soprano), Emilia; Nello Romanato (tenor), Cassio; Fernando Corena (bass), Lodovico; Tom Krause (baritone), Montano; Vienna State Opera Chorus and Vienna Philharmonic Orchestra, Herbert von Karajan cond. LONDON LOR 90038 two reels \$21.95.

Interest: Verdi masterpiece  
Performance: Polished  
Recording: Slight the singers  
Stereo Quality: Theatrical

After the superb achievement represented in its *Aida* tape under Karajan's baton with the Vienna Philharmonic, it would be reasonable to expect London Records to produce an equally great

*Otello*, given such a pair as Del Monaco and Tebaldi in the lead roles. However, even though each of the four acts can be heard without interruption, it must be said with regret that we are faced with a near miss.

In the musical-dramatic-vocal department, it is Aldo Protti's Iago that lets us down, for he emerges as more crude than sinister. We do not sense in his vocalism the characterization of Iago's psychopathic cunning that threads its way throughout the orchestral fabric provided by Verdi. The Cassio of Nello Romanato, for its part, is rather lacking in virility. Let it be said, on the other hand, that Del Monaco as the Moor provides full measure of heroism, passion, and pathos, and that Tebaldi is incomparable as Desdemona.

But now we come to the two real problems of this recorded performance: the conducting, and the balances between solo singers and orchestra. Karajan cannot be faulted significantly on either basic tempos or dynamics; but, as has too often been the case with him, dramatic passion is subordinated to tonal and rhythmic polish. A comparison with Toscanini's 1947 performance recorded on RCA Victor reveals this almost at once. Only in the final act does the agony and bitter pathos of Verdi's great score emerge in all its harrowing horror, passion, and beauty, and for this Del Monaco and Tebaldi deserve most of the credit, along with Ana Raquel Satre as Emilia.

Even more serious, however, is the way the orchestra is allowed to override the singers in the most crucial and climactic moments of the drama, in particular the end of the Act I love duet and the Act II exchanges between Otello and Iago. Indeed, the words of simultaneous dialogue between Otello and Desdemona

on one side of the stage (as she seeks pardon for Cassio) and between Iago and Emilia on the other side (as he snatches the talisman-handkerchief) are almost completely lost. This type of aural unbalance extends even to the organ pedal note that Verdi prescribed for the opening storm scene; for instead of being a vibration more felt than heard, it emerges here as an obtrusive rumble. The sound quality of the tape as a whole is splendidly rich in texture, but there is an occasional trace of bass overload in the climaxes and the background hiss is a bit high.

Do these faults invalidate this *Otello* as a listening experience? Definitely not. The production is far above the average live performance and musically superior to any available on records, save Toscanini's. However, when one is dealing with such a masterpiece as this, the critic is forced to evaluate the performance in terms of what the musical drama demands; and since the demands here verge on the overwhelming, any insufficiencies or misjudgments—musical, dramatic, or sonic—become that much more glaring.

For better or worse, this is the best recorded version of *Otello* presently available, and we are not likely to hear it surpassed for some years. The tape version lacks a libretto, but it can be obtained readily from London Records.

D. H.

© **VERDI: *Requiem***. Leontyne Price (soprano); Rosalind Elias (mezzo-soprano); Jussi Bjoerling (tenor); Giorgio Tozzi (bass). Vienna Philharmonic and Chorus of the Society of the Friends of Music, Fritz Reiner cond. RCA Victor FTC 7001 \$14.95.

Interest: Verdian masterpiece  
Performance: Unexcelled  
Recording: Near-perfect  
Stereo Quality: Fittingly big

The only thing really wrong with this tape is the turnover break, which occurs in the middle of the "*Lacrymosa*." Side One ends with the surging climax reached on the words "*Huic ergo parce Deus*," sung by the vocal quartet and full chorus. It should lead, after no more time than the principals need to take a deep breath, to the trio that introduces the *Pie Jesu*. By lopping off the *Pie Jesu* from the first sequence, the continuity that only tape allows is broken.

One of three outstanding performances on discs (Toscanini's and De Sabata's being the other two) and easily the better of the two existing stereo versions, Reiner's is the first to be listed in the tape catalog and should remain unchallenged for years to come. The power of the *Dies Irae*, the intensity of the *Tuba Miram* and *Rex Tremendae*, all captured by the realistic recording, are com-

DEL MONACO, KARAJAN, AND PROTTI  
The recording engineers let them down





plemented by the pure gold of Leontyne Price's "Libera Me" and the late Jussi Bjoerling's "Ingemisco." The blend of the four solo voices elsewhere, the balance of choral and orchestral forces, and the utter transparency could be no better. If the recorded level is a little low, the dynamic range it encompasses is tremendous. Print-through is rarely noticeable.

The beautifully printed booklet that accompanies the Soria disc edition is not included with the tape, but it may be secured from RCA Victor at no charge. C. B.

© **VIVALDI: Gloria, in D Major.** Mimi Coertse and Ina Dressel (sopranos); Sonja Draxler (contralto). Vienna State Opera Orchestra and Vienna Academy Chorus, Hermann Scherchen cond. WESTMINSTER WTC 153 \$7.95.

Interest: Glorious Vivaldi  
Performance: Impeccable  
Recording: Clean but thin  
Stereo Quality: Very good

This splendid recording has been sloppily transferred to tape. First, the review copy was not in D but in E-flat. There is at least a half-tone difference between the disc and tape editions. The disc sound is also fuller and more balanced; the tape is decidedly weak on the bass end. Add to these serious flaws a fairly low volume level and a correspondingly high degree of tape hiss, with some print-through (at the beginning of the *Gratias* and to a lesser extent elsewhere). The performance itself, the first in this medium, is exemplary. C. B.

#### 4-TR. ENTERTAINMENT

© **JOAN BAEZ, VOL. 2.** Joan Baez (vocals and guitar). *Wagoner's Lad; The Trees They Do Grow High; The Lily of the West; Silkie*; and ten others. VANGUARD VTC 1638 \$7.95.

Interest: British-American balladry  
Performance: Appealing  
Recording: Clean  
Stereo Quality: Good but unnecessary

Barely over twenty, Joan Baez is one of those young artists whose reputations have been virtually made by recording. Her first, simply titled "Joan Baez" (Vanguard VTC 1635), introduced a folk singer of rare talent and luminous voice. Her ability to communicate a range of feeling without affectation is again matched, in this second volume, by the strong sense of character she conveys. Her repertoire embraces a few of the classic Child ballads as well as songs of the Ohio and the Appalachians. In two of the latter she is assisted by the three Greenbriar Boys, singing in the best Bluegrass tradition. The recording



LEONTYNE PRICE  
Pure vocal gold for Verdi

itself has remarkable presence and beautiful clarity. C. B.

© **DAVE BRUBECK: Tonight Only!** Carmen McRae (vocals); Dave Brubeck Quartet. *Melantha; Weep No More; Talkin' and Walkin'; Briar Bush*; and five others. COLUMBIA CQ 413 \$6.95.

Interest: Brubeck with vocals  
Performance: Off and on  
Recording: Fine  
Stereo Quality: Pronounced

The opening and closing numbers here are standouts. *Melantha*, a supple blues for the Brubeck Quartet alone, is drawn from an opera-in-progress based on one of Gertrude Stein's "Three Lives." The title piece winds up the set with a bright, free-swinging dialogue between Brubeck and his drummer, Joe Morello. Carmen McRae is heard in that classic of scat *Paradiddle Joe* and in vocal settings of three tunes previously recorded by Brubeck and his men as instrumentals. None of the latter benefit particularly from the added lyrics, nor does Miss McRae's rather detached singing style make them sound any less banal than they are. *Strange Meadowlark*, for one, sounds a good deal better in the haunting, more extended instrumental version on the quarter's two-track tape "Time Out" (Columbia GCB 72). Of average interest are saxophonist Paul Desmond's lyric *Late Lament* and bass player Eugene Wright's amiable *Talkin' and Walkin'*. The recording is clean and highly directional. C. B.

© **CHICAGO AND ALL THAT JAZZ.** Lil Armstrong and Blossom Seeley (vocals); Jack Teagarden (trombone and vocals); Eddie Condon (guitar);

One year in the making... the most advanced  
and flexible of all stereo recording techniques

phase 4 stereo  
*Time After*

LONDON  
RECORDS

CIRCLE NO. 28 ON READER SERVICE CARD

without question  
the finest\*



ask your dealer  
for a  
demonstration

\* IN HIGH FIDELITY SPEAKER SYSTEMS

IONOVAC DIVISION  
DUKANE CORPORATION  
DEPT. HFS-72 / ST. CHARLES, ILL.

Where can I hear a demonstration?  
 Please send me available information

NAME \_\_\_\_\_  
FIRM (if dealer) \_\_\_\_\_  
ADDRESS \_\_\_\_\_  
CITY \_\_\_\_\_ STATE \_\_\_\_\_

CIRCLE NO. 39 ON READER SERVICE CARD



Bud Freeman (tenor sax); Gene Krupa (drums); Jimmy McPartland (trumpet); Pee Wee Russell (clarinet); others. *Logan Square; Chicago; China Boy; Take Me To the Land of Jazz*; and five others. VERVE VSTC 266 \$7.95.

Interest: Chicago redivivus  
Performance: Pros all  
Recording: Good  
Stereo Quality: Distinct

The vitality and joy of early Chicago jazz is recaptured in this set by old-timers, some of them still very active professionally. Except for Pee Wee Russell and Bob Haggart (on bass), the personnel here were all once members of the band that called itself McKenzie-Condon's Chicagoans. After some three decades they sound pretty good, and the music they make has a refreshingly authentic ring. The distaff contributions, too, are outstanding, Lil Armstrong's hefty *Original Boogie* and the *Chicago* duet she sings with Blossom Seeley among them. Technically a good job. C. B.

© NAT COLE AND GEORGE SHEARING: *Nat King Cole Sings/George Shearing Plays*. Nat Cole (vocals); George Shearing (piano), and Quintet; string orchestra, Ralph Carmichael cond. *September Song; Pick Yourself Up; I Got It Bad; Let There Be Love*; and eight others. CAPITOL ZW 1675 \$7.95.

Interest: Great tunes  
Performance: Flawless teamwork  
Recording: Rich  
Stereo Quality: Very good

Nat Cole's caressing style and George Shearing's suave fingerwork recreate a dozen well-chosen mood pieces over some attractive string arrangements by conductor Ralph Carmichael—in sum, a reel as easy and pleasant to listen to as any in a good while. Predominantly low-key ballads like *Azure-Té, In Other Words*, and *I'm Lost* are offset by two up-numbers, *Pick Yourself Up* and *Let There Be Love*, among the best in the set. Though Cole's voice is a little too forward, the sound is full and evenly balanced. C. B.

#### RECORDING OF SPECIAL MERIT

© ELLA FITZGERALD: *Clap Hands, Here Comes Charlie*. Ella Fitzgerald (vocals); jazz combo. *Night in Tunisia; You're My Thrill; My Reverie; Stella By Starlight*; and ten others. VERVE VSTC 265 \$7.95.

Interest: More Ella  
Performance: At her best  
Recording: Live  
Stereo Quality: Tasteful

Easygoing is the word for Ella's singing here: tender and compassionate in songs like *You're My Thrill* and *Good Morning Heartache*, slow burning in *Cry Me a River*, and casually swinging in an oldie like *The Jersey Bounce*. Of the incredible number of tapes to her credit, this one should be put near the top. The small combo that accompanies her is unnamed, but its backing is consistently inventive and provides solid support. The engineering is first-rate, and Ella's placement is just right. C. B.

© STAN KENTON: *Sophisticated Approach*. Orchestra, Stan Kenton cond. *How Long Has This Been Going On?; Memoirs of a Lady; Time After Time; Easy To Love*; and eight others. CAPITOL ZT 1674 \$6.95.

Interest: Dreamsville  
Performance: Languid  
Recording: OK  
Stereo Quality: Marked

Kenton's idea of sophistication is reflected in smooth, unhurried tempos and the close harmonies that are his trademark. His moods here conjure up a picture of two cigarettes glowing in the long-after-darkness, but the picture is one that fails to sustain interest. The sameness of Lennie Niehaus's orchestrations soon becomes wearing, despite some nice alto and tenor sax solos in numbers like *Easy To Love* and *It Might As Well Be Spring*. The recording tends to be bass-heavy, and this, combined with the whiteness of Kenton's brass on top, creates a kind of tonal hole-in-the-middle. Stereo distribution is otherwise even, and directionality is pronounced. C. B.

© JAZZ POLL WINNERS. Various jazz groups and instrumentalists. *Kind of Blue; Blue Moon; Cloudburst; Night in Tunisia*; and eight others. COLUMBIA CQ 385 \$6.95.

Interest: Jazz panorama  
Performance: Variable

ANDRÉ PREVIN  
*Tailor-made  
pianistic opulence  
for pop standards*



COLUMBIA RECORDS

Recording: Very good  
Stereo Quality: High

If this collection is somewhat more effective than most of the compendiums that bring together the winners of the various popularity polls conducted annually by the jazz press, it is because Columbia had a sizable roster of top jazz talent under contract at the time it was made and because the selections were chosen with some taste. Among the high spots are Miles Davis's *Kind of Blue*, Dave Brubeck's *Blue Rondo a la Turk*, Charlie Mingus' *Better Git It in Your Soul*, and Gerry Mulligan's *As Catch Can*. All selections are available, by the way, in disc collections by the individual artists. C. B.

© ANDRÉ PREVIN: *A Touch of Elegance*. André Previn (piano); orchestra, André Previn cond. *I Got It Bad; Satin Doll; Perdido; Solitude*; and eight others. COLUMBIA MQ 423 \$6.95.

Interest: Homage to Duke  
Performance: Smooth  
Recording: Rich  
Stereo Quality: Very good

Except for the title number, Previn's own, this collection constitutes a musical salute to Duke Ellington. And an extremely attractive one it is. Previn has a knack of taking classic tunes like *Satin Doll, Solitude*, and *Prelude to a Kiss*, as he does here, and clothing them opulently like mannequins in a shop window, without distorting their basic shape. Himself at the piano, with Red Mitchell on bass, Frank Kapp on drums and backing by some twenty strings, Previn is as respectful of Ellington's lyric genius as he is inventive in his arrangements. If music can be described as sounding "expensive," this is it, exemplified in part by his exquisitely tailored *Sophisticated Lady* and a suave little piece the Duke contributed especially for the occasion, *Le Sucrier Velours*. The recording itself has a lovely sheen. C. B.



HiFi/Stereo

ENTERTAINMENT

POP HUMOR FILMS  
Pops Theater FOLK

Reviewed by JOE GOLDBERG • STANLEY GREEN • NAT HENTOFF

Explanation of symbols:

Ⓜ = monophonic recording

Ⓢ = stereophonic recording

\* = mono or stereo version not received for review

Ⓢ Ⓜ PAUL ANKA: *Young, Alive, and in Love!* Paul Anka (vocals); orchestra, Ray Ellis cond. *Young and Foolish; This Love of Mine; I Love You;* and nine others. RCA Victor LSP 2502 \$4.98, LPM 2502\* \$3.98.

Interest: Celebration of youth  
Performance: Self-congratulatory  
Recording: Good

At twenty, Paul Anka is a protean force in the pop music world. His records score consistently high international sales, he has written several hit songs, he is booked into adult oases, and he has recently been recruited into films. In person, Anka's vitality and extroverted showmanship explain much of his appeal, but on records he is an ordinary vocalist with limited expressive range.

In this ode to youth, Mr. Anka has been packaged with care. A chorus wanders in and out of the rites, singing special material by Jimmy Van Heusen and Sammy Cahn, and there are lighthearted arrangements by Ray Ellis. At the center of the vernal ceremony is a very confident young man, but the musical reason for that confidence escapes this reviewer.

N. H.

Ⓢ Ⓜ RAY CHARLES: *Modern Sounds in Country and Western Music.* Ray Charles (vocals); orchestra. *You Don't Know Me; Worried Mind; Hey, Good Lookin';* and nine others. ABC-PARAMOUNT ABCS 410 \$4.98, ABC 410\* \$3.98.

Interest: "Tex" Charles  
Performance: A patchwork of styles  
Recording: Good  
Stereo Quality: First-rate

Having moved from the bottomlands of rhythm-and-blues and jazz to the pastures of pop music, Ray Charles is trying to gather the rest of the popular harvest with his first country-and-western album. Actually, the arrangements have con-

siderably diluted the salty sentimentality of these tunes as they were first performed. The big-band scores are simply structured swingers, and the tracks with strings—which also include a choir of city slickers—are arranged in the conventional pop ballad manner.

Ray Charles himself tries occasionally to emulate the cadences of the country-and-western style. Essentially, however, he sings these tunes in the same way he treats pop standards, bringing to them the sound, pulse, and feeling of the blues, but without its rawer edges. Because of his singularly inviting warmth and proud poignancy, Charles is always worth hearing, no matter how inapposite the musical material.

N. H.



DECCA RECORDS

SAMMY DAVIS, JR.  
*His latest is his best yet*

Ⓢ Ⓜ BOBBY DARIN: *Sings Ray Charles.* Bobby Darin (vocals); orchestra, Jimmy Haskell cond. *I Got A Woman; The Right Time; That's Enough;* and eight others. Arco S 33-140 \$4.98, 33-140\* \$3.98.

Interest: Essay in acculturation  
Performance: Semi-successful  
Recording: Good  
Stereo Quality: Very good

This is more than a tribute to Ray Charles. In interpreting eight Charles originals and three songs with which the blues singer has also become associated, Darin tries to sing in what he conceives to be the Negro rhythm-and-blues tradition. He has affected a throaty, "down home" sound; and his exclamatory

phrasing is a cross between the gospel and the street rhythms at the center of Ray Charles's style.

At first hearing, Darin's imitation is surprisingly successful, and he is helped by tenor saxophonists Plas Johnson and Nino Tempo as well as the Blossoms (a fervent vocal team that once worked with Charles). Despite the liner notes, however, I do not find any "simple eloquence" in Jimmy Haskell's arrangements. They are as narrow and mechanical as most rhythm-and-blues frameworks for Negro or white artists.

After several playings, Darin's "new" identity begins to pall, and this aural costume party becomes increasingly annoying. For all his empathy with Negro blues, Darin is at best a skillful mimic, not an authentic guild member.

N. H.

Ⓢ Ⓜ SAMMY DAVIS, JR.: *Belts the Best of Broadway.* Sammy Davis, Jr. (vocals); orchestra, Marty Paich cond. *My Romance; Falling In Love with Love; Something's Coming;* and nine others. REPRISE 9-2010 \$4.98, 2010\* \$3.98.

Interest: Topnotch collection  
Performance: Frequently exciting  
Recording: Splendid  
Stereo Quality: All right

This is the finest work I've ever heard Sammy Davis do on records. He shows here a far greater involvement in his material than before, and more ability to project the meaning of a song. In fact, the album title is something of a misnomer. *My Romance* (begun to the accompaniment of a solo guitar) and *Last In the Stars*, for example, get genuinely expressive, nonbelted interpretations that rank with the best. Of course, when called for, Davis can pull out all the stops, particularly in such hard-driving items as *Something's Coming* and *A Lot of Living to Do*. Altogether, an intelligently planned, well-executed album.

S. G.

Ⓢ Ⓜ JONATHAN AND DARLENE EDWARDS: *Sing Along with Jonathan and Darlene Edwards.* Jo Stafford (vocals), Paul Weston (piano), and male chorus. *Pretty Baby; Tiptoe Through the Tulips; On Moonlight Bay;* and nine



# SAVE OVER 40% ON HI-FI

USE OUR EASY-PAY-PLAN Up to 24 months to pay

2418/Bell 30 Watt Stereo Amp ..... \$109.95  
 RC86/11 Garrard 4/Speed Stereo changer 59.50  
 108-Audio Empire Diam. Stereo Cart. . . . 35.00  
 2-Famous make 3-way spkr. systems—  
 walnut bookshelf ..... 119.90  
 All Interconn. cables & Inst. .... 4.50

Buy with Confidence. Your Money Back within 15 days if not Completely Satisfied.

Catalog Price .... \$328.85  
 YOUR COST ..... 195.00  
 You Save Over 40% ..... \$133.85

DON'T BUY ANY HI-FI components until you write for our low, low quotation under our guaranteed "We Will Not Be Undersold" Policy. Let us prove that dealing with "Hi-Fidelity Center" is just like "Having a friend in the business."

WHOLESALE CATALOGUE & BEST BUY LIST—FREE  
 TRADE-INS—In addition to low, low prices we offer highest trade-in allowances for your old equipment. Send us your list.

## ELECTRONIC WORLD HI-FI RECORDING TAPE

7" Spools - Splice Free - Freq. Resp. 30-15KC

		3-23	24 & Up
12A	1200' Acetate	1.09 ea.	.99 ea.
12M	1200' Mylar	1.19 ea.	1.09 ea.
18A	1800' Acetate	1.59 ea.	1.45 ea.
18M	1800' Mylar	1.99 ea.	1.85 ea.
24M	2400' Mylar	2.59 ea.	2.49 ea.

You may obtain 24 plus price on a mixed selection of any 24 items. Add 15¢ per reel for postage & handling. 10¢ 24 or more.

# HI-FIDELITY

CENTER

"The House Of Low Low Prices"

220-H East 23rd St., New York 10, N.Y.

CIRCLE NO. 25 ON READER SERVICE CARD

"Rank among the leading folk interpreters...Ballads, country songs, spirituals, western songs and the like, all done to the hilt. A poignant solo version of 'Brother Can You Spare A Dime' is alone worth the cost." *Washington Star*

"One of the best albums by the Weavers...an exciting program of folk tunes reflecting various events, places and people of America." *The Billboard*

"'Bye Baby Bye' is sheer delight, and in the gospel-flavored 'Fight On' the Weavers raise the roof fully as high as in the days of yore." *Saturday Review*

Newest Release!

## THE WEAVERS' ALMANAC



VRS-9100 (mono) VSD-2102 (stereo)

VANGUARD RECORDS

Send for catalog. Vanguard 154 W. 14 St., N.Y.

CIRCLE NO. 36 ON READER SERVICE CARD

92

others. RCA VICTOR LSP 2495 \$4.98, LPM 2495\* \$3.98.

Interest: Two on a Mitch  
 Performance: Has its moments  
 Recording: Great  
 Stereo Quality: Effective

"Jonathan and Darlene Edwards" (better known as Paul Weston and Jo Stafford) have apparently built up such a wide following with their previous albums that they have now enlarged their horizon, if not their talent, with a sing-along collection. The humor of listening to an uncertain, off-key singer and her mitten-fingered accompanist has its moments, but the deadly sounds of the poker-voiced, barrel-chested male chorus may strike you as even funnier. Stereo puts "Darlene" left, "Jonathan" right, and the chorus in between. S. G.

© ® EILEEN FARRELL: *This Fling Called Love*. Eileen Farrell (soprano); orchestra, Percy Faith cond. *Hello, Young Lovers; My Romance; In the Still of the Night; Stormy Weather; Out of this World; I Never Has Seen Snow; I've Got You Under My Skin; Where Or When; The April Age; The Party's Over; The Faraway Part of Town; Can't Help Lovin' Dat Man*. COLUMBIA CS 8539 \$4.98, CL 1739\* \$3.98.

Interest: Pops by Farrell  
 Performance: Pleasurable  
 Recording: Excellent  
 Stereo Quality: Tasteful

Just when it began to look as if Eileen Farrell were doomed forever to a series of misdirected pop efforts, along comes "This Fling Called Love" and criticism is disarmed. It is by all odds the most successful album she has made in her recent light-music fling for Columbia, and certainly it is as pleasurable a collection as has been heard in some time.

Credit, I assume, must go in large measure to conductor Percy Faith. His arrangements, while not notably brilliant, offer genuine support—not competition—at all times. The song and its meaning is uppermost throughout the program. There's not a trace of the I'm-a-jazz-singer-too approach that left this listener dazed and puzzled by what Miss Farrell was trying to do in her two most recent pop sets. Certainly, there was never any doubt that she had the voice or intelligence to interpret a popular song. But it has not been until this recital that her great natural gifts have been allowed to shine without being forced to project songs in a manner alien both to her training and her temperament.

Ten out of the twelve selections on "This Fling Called Love" are well-known show tunes. Though most of them have been done to near death, they take on added luster and an occasionally



EILEEN FARRELL

*Fine work, helped by superior backing*

deeper significance in Miss Farrell's interpretations. In *The Party's Over*, for example, the story of a lost love becomes genuinely moving.

Columbia's engineers have furnished a lovely sound, the stereo is tasteful, and I couldn't be happier. S. G.

© ® FRANCES FAYE: *Swinging All The Way*. Frances Faye (vocals); orchestra, Marty Paich cond. *Love for Sale; Miss Otis Regrets; That's All; and nine others*. VERVE V6 8434\* \$5.98, V 8434 \$4.98.

Interest: Pop hipster  
 Performance: Highly individual  
 Recording: Very good

Frances Faye, a favorite in the nation's more sophisticated night clubs, has a number of vivid assets. Her voice is husky and hot, and her sharp-edged phrasing is shaped with confidence. More intelligent than most pop singers, Miss Faye draws from the lyrics more than they sometimes deserve. Her major liability is a narrowness of approach. She has some of the surface characteristics of the jazz hipster: the role of the seasoned existentialist who can no longer be surprised. The result is a kind of emotional obliqueness, especially in the ballads. She conveys the impression of a gunslinger constantly practicing looking tough before a mirror.

Marty Paich's scores are well constructed. He has molded them to Miss Faye, but he has also tried to provide some of the flowing lyricism she lacks. N. H.

© ® ELLA FITZGERALD AND NELSON RIDDLE: *Ella Swings Brightly With Nelson*. Ella Fitzgerald (vocals); orchestra, Nelson Riddle cond. *When Your Lover Has Gone; Don't Be That Way; I Hear Music; and nine others*. VERVE 64054 \$4.98, 4054\* \$3.98.

Interest: Ella-Riddle reunion  
 Performance: Standard Ella

HIFI/STEREO REVIEW



Recording: Good  
Stereo Quality: OK

Ella Fitzgerald is like an innocent child skipping over the meadows of the world, completely oblivious to the broken hearts and beer bottles around her. Her commitment is only to the musical values of a song, with which she deals superlatively. Hers is a sunny, naïve approach, and bright, uncomplicated songs like *I Won't Dance* are excellent vehicles for her.

Unfortunately, much of the material here is composed of songs of sadness, passion, and heartache, and on those she only does half her job. The exaltation of a song like *Alone Together* is meaningless to her, and when, on the opening line of Ellington's *What Am I Here For?*, she swings blithely through "*What am I here for, living in misery?*" the effect is ludicrous.

Nelson Riddle, who made the "Gershwin Song Book" albums with Miss Fitzgerald, is one of the two or three best pop arrangers, and some of his collaborations are classics, but here his style seems to have hardened into formula. The songs themselves are excellent, and Miss Fitzgerald sings them the way she sings everything else. If you like her, you'll love this. J. G.

© ® ARETHA FRANKLIN: *The Electrifying Aretha Franklin*. Aretha Franklin (vocals and piano); orchestra, Richard Wess or Bob Mersey cond. *You Made Me Love You; I Told You So; That Lucky Old Sun*; and nine others. COLUMBIA CS 8561 \$4.98, CL 1761\* \$3.98.

Interest: Gospel-rooted pops  
Performance: Energetic  
Recording: Excellent  
Stereo Quality: Good

Miss Aretha Franklin is a female Ray Charles-turned-pop, which is another way of saying that she employs the conventions of gospel singing on popular material. Her piano playing indicates that she is probably more truly in the gospel tradition than Charles, but she lacks the power and depth with which he turns banal material into art.

Young Miss Franklin has completely bypassed the sort of recording apprenticeship undergone by Charles. With this, her second album, she steps into a showbiz act, superficially exciting but with little staying power. J. G.

© ® JONI JAMES: *After Hours*. Joni James (vocals), Pete Jolly (piano), Howard Roberts (guitar), Ralph Pena (bass), Shelley Manne or Milt Holland (drums). *I'll Remember April; Can't Get Out of This Mood; Do Nothin' Till You Hear from Me*; and nine others. MGM SE 4008\* \$4.98, E4008 \$3.98.

Interest: Jazz isn't for Joni  
Performance: Five wasted jazzmen  
Recording: Clear and bright

Joni James has recorded in many contexts—Irish, Italian, and country songs among them. Now she's been turned loose, so to speak, with a jazz combo. Alas, this latest change of scene does not help. Miss James is simply a stiff, characterless singer. Her voice has no intrinsically arresting texture, her beat is mechanical, her phrasing is self-conscious, and her intonation is wobbly. The jazzmen prevent the session from collapsing into a farce, but I do think that on the second side drummer Milt Holland might have been less heavy. Then again, perhaps he felt it was necessary to keep reminding Miss James where the beat was. N. H.

® STEVE LAWRENCE: *Lawrence Goes Latin*. Steve Lawrence (vocals); orchestra, Don Costa cond. *Just in Time; Too Close for Comfort; Tonight*; and nine others. UNITED ARTISTS UAL 3114 \$3.98.

Interest: Latinized show tunes  
Performance: Pro at work  
Recording: Very good

Although he has been sounding more and more like Sinatra on his recent releases, Steve Lawrence turns up here sounding like Steve Lawrence again. And I couldn't be happier. Mr. Lawrence has always struck me as being one of the most polished young singers around, and while I'm not very happy about the Latinizing of a dozen show tunes, I do feel that his intelligence and musicianship somehow make the whole thing come off. Well almost. S. G.

© ® PEGGY LEE: *Blues Cross Country*. Peggy Lee (vocals); orchestra, Quincy Jones cond. *Basin Street Blues; San Francisco Blues; The Train Blues*; and nine others. CAPPROL ST 1671 \$4.98, T 1671\* \$3.98.

Interest: Medium-strength blues  
Performance: She's been better  
Recording: Superior  
Stereo Quality: Excellent

There are several things wrong with this transcontinental junket, and one of them is the material. Much of the album is made up of new, geographically oriented blues, and the lyrics are, for the most part, appallingly flat. In her capacity as a collaborating songwriter, Miss Lee is responsible in part for seven of these failures.

Miss Lee's singing is acceptable, but she seems to be playing with the idea of the blues rather than plunging into the self-exposing, emotional core of the tradition. She is, in short, a sympathetic

HERE'S **PROOF** YOU ALWAYS GET  
**Rock-Bottom Prices**  
WITH CONVENIENT TIME PAYMENTS AT



- Unless you're a multi-millionaire get our quote, like these shrewd buyers did!
- These excerpts from letters in our files are proof positive that RABSONS PRICES ARE ROCK BOTTOM! Your purchase backed by our reputation for 57 years of RELIABILITY! PLUS our six (6) months guarantee, instead of the usual 90 days. STANDARD NAME BRAND LINES.
- From "B.M." North Carolina—  
"I was pleased with your quotation on my proposed Hi-Fi set, as it was \$30.00 less than the next lowest bid of over ten."
- From "W.W.B." California—  
"Your package quote was best I received."
- From "J.K.B." New York State—  
"Yours was the lowest of six quotations."
- From "G.E.M." Ohio—  
"Your quotation was prompt and I was influenced by the six months warranty offer."
- FREE—With our quote on the equipment or system of your choice we will include a \$1.00 genuine Miracle Record Cleaning Cloth.

**Rabsons - 57 ST., Inc.** Dept. 10B  
119 West 57 St., New York 19, N.Y.

(Diagonally opposite Carnegie Hall)  
CIRCLE NO. 29 ON READER SERVICE CARD

# YOU SAVE MONEY!

RUSH US YOUR  
LIST OF HI-FI  
COMPONENTS  
FOR A SPECIAL  
QUOTATION

WRITE FOR FREE  
AUDIO DISCOUNT  
CATALOG A-15

New low prices on  
amplifiers, tuners, tape  
recorders, speakers, etc.

**KEY** ELECTRONICS CO.  
120 LIBERTY ST.  
NEW YORK 6, N.Y.

CIRCLE NO. 26 ON READER SERVICE CARD



# PURCHASING A HI-FI SYSTEM?

TIME PAYMENTS AVAILABLE

Up to 2 years to pay!

Send Us  
Your List Of  
Components  
For A  
Package  
Quotation

AIREX  
WON'T BE  
UNDERSOLD

All merchandise is  
brand new, factory  
fresh & guaranteed.

Free Hi-Fi Catalog

## AIREX RADIO

CORPORATION

85-MR Cortlandt St., N.Y. 7, WO 4-1820

CIRCLE NO. 2 ON READER SERVICE CARD



If you've recently changed your address, or plan to in the near future, be sure to notify us at once. We'll make the necessary changes on your mailing plate, and see to it that your subscription continues without interruption. Right now — print the information requested in the spaces below and mail it to: HiFi/STEREO REVIEW, 434 So. Wabash Ave., Chicago 5, Illinois.

Name *Please PRINT!*

\*Account No.

Old Address

City State

New Address

City Zone State

Mail copies to new address starting with \_\_\_\_\_ issue.

\*(Your Account Number appears directly above your name on the mailing label.)

Jim Lansing\*  
Altec Lansing  
Electrovoice  
Jensen  
Hartley\*  
University  
Acoustic Research  
Janszen  
Wharfedale  
USL Citizen Band  
International Crystals  
Gonsel\* Hallcrafters  
Texas Crystals  
Concertone\* Viking  
Bell\* G.E.  
Weathers  
Harman—Kardon  
Eico\* Pilot\* TEC  
Sherwood\*  
ESL\* Frazier  
Superscope  
Dual Changer  
Bogen\* RCA  
Dynakit\* Fisher  
H. H. Scott  
Thorens\*  
Conrac  
DeWald  
Sony\* Roberts  
Challenger  
Wollensak\* National  
Garrard\* Norelco  
Miracord  
Glaser—Steers  
Rek-O-Kut  
Polytronics  
Tandberg\*  
Fairchild  
Pickering\* Sonar  
Audio Tape  
Magnecord\*  
Rockford Cabinets  
\*Fair Traded

tourist here rather than an indigenous participant. Quincy Jones has assembled a spirited band, and has juggled the usual orchestral clichés—many of them from Count Basie's bag—for the session. The recorded sound is spacious and lustrous. N. H.

### RECORDING OF SPECIAL MERIT

Ⓢ Ⓢ FRANK SINATRA: *Sinatra and Strings*. Frank Sinatra (vocals); orchestra, Don Costa cond. *Misty; It Might As Well Be Spring; Prisoner of Love; That's All*; and six others. REPRISÉ 91004, \$5.98, 1004 \$3.98.

Interest: Frank in new setting

Performance: In the vein

Recording: Rich

Stereo Quality: Good

With this release on his own Reprise label Frank Sinatra continues two simultaneous projects: recording the best of America's popular music, and making public his second thoughts about the songs that became identified with him in his first surge of fame. With a song like *Night and Day*, one can see quite clearly the mature ease and authority that has come to him in the decade since his first Capitol album proclaimed him our best singer of popular songs.

The Sinatra voice is more smokily husky than in some other recent releases, but as usual he concentrates on the thing he does better than anyone now singing: the meaningful interpretation of lyrics. An arranger new to him, Don Costa, is not as personal as either Nelson Riddle or Gordon Jenkins, but he sets off Sinatra to excellent advantage.

When Sinatra is at the top of his form, as he is here, any selection of "best" must be extremely personal. All of his moods are present: a wistful *I Hadn't Anyone Till You*; a cocky *Come Rain or Come Shine*; a defiant, disillusioned *All Or Nothing At All*; an elegiac, chilling *Yesterdays*. But truly unique is the tender, caressing *Stardust*, on which only the verse is sung, in an arrangement that sets it off like the rare gem it is. J. G.

Ⓢ Ⓢ KAY STARR: *I Cry By Night*. Kay Starr (vocals); orchestra. *More than You Know; Lover Man; P.S. I Love You*; and nine others. CAPITOL ST 1681 \$4.98, T 1681\* \$3.98.

Interest: Torch repertoire

Performance: Style over substance

Recording: OK, but some surface noise

Stereo Quality: Wide dispersion

Kay Starr is a quasi blues singer who has learned the right mannerisms without learning the knack of projecting an emotion as if she really believed every self-pitying word. She is a properly throaty vocalist who can break up the monosyl-

labic words into as many syllables as she feels she can get away with, but she still fails to establish the close identification with her material that is so essential to this kind of program. Nice to hear again, though, such songs as *My Kinda Love* and *Whispering Grass*. S. G.

Ⓢ JIMMY REED: *The Best of Jimmy Reed*. Jimmy Reed (vocals, guitar, and harmonica), "Lefty" Bates (guitar), Earl Phillips (drums). *Hush-Hush; Found Love; Honest I Do*; and nine others. VEE JAY 1039 \$3.98.

Interest: Primitive blues singer

Performance: Lacks variety

Recording: Poor

This is a recreation of blues singer-guitarist-harmonica player Jimmy Reed's best-known recordings. Reed himself is a primitive, but the group with which he works almost always spills over the rhythm-and-blues borderline, so this is music that will probably offend purists of both folk and pop camps. On the other hand, the set offers a fascinating glimpse of the cross-fertilization that has been going on in various blues styles. You can even see how this can be simplified and exaggerated to become the Twist.

Reed's monochromatic appeal is primarily visceral, even though he sings some of his songs with apparent disinterest. For any but the most dedicated, there is likely to be a deadly sameness about the performances after three or four tracks. The hardy souls willing to contend with that must also deal with poor surfaces, and fadeouts on every track. J. G.

Ⓢ Ⓢ MEL TORMÉ: *My Kind of Music*. Mel Tormé (vocals); orchestra. *Born To Be Blue; By Myself; Alone Together*; and eight others. VERVE 68440 \$5.98, V 8440 \$4.98.

Interest: Polished technician

Performance: Overly precise

Recording: Good

Mel Tormé has the reputation of being a singer's singer. Perhaps this is because he does everything absolutely correctly. On this album, however, it works to his disadvantage. The set is about equally divided between the work of the great team of Howard Dietz and Arthur Schwartz and Tormé's own very good songs. He has unerringly picked the best of Dietz and Schwartz (*Alone Together, By Myself, Dancing in the Dark*), which is about the best there is, and he certainly should have an understanding of his own work. But one is always conscious of the singer, not the song—so much so that neither comes through. Technique does not guarantee communication. J. G.

(Continued on page 97)



MORE ENTERTAINMENT REVIEWS

IN BRIEF

DATA

COMMENTARY

Ⓢ Ⓜ CLANCY'S CLOWNS: *Saxophobia*. Johnny Smith cond. *Charleston*; *Pretty Baby*; *Varsity Drag*; and nine others. CAPITOL ST 1614 \$4.98, T 1614\* \$3.98.

Clancy's Clowns are notable for playing dexterity and imaginative arrangement. The five moaning, wah-wahing saxes, unaccompanied, may well be the Twenties' revenge on the percussion-pounding Sixties. Pronounced stereo. S. G.

Ⓢ Ⓜ EYDIE GORMÉ: *I Feel so Spanish!* Eydie Gormé (vocals); orchestra, Don Costa cond. *Besamé mucho*; *Frenesi*; *My Heart*; and nine others. UNITED ARTISTS UAS 6152 \$4.98, UAL 3152\* \$3.98.

Eydie Gormé has no difficulty getting the message across. Here it comes from south of the border, and includes chachas and boleros sung in both Spanish and English. Stereo quality is satisfactory. S. G.

Ⓢ Ⓜ MORTON GOULD: *Kern and Porter Favorites*. Morton Gould and his orchestra. *Jockey on the Carousel*; *Can I Forget You? I Get a Kick Out of You*; and eight others. RCA VICTOR LSC 2559 \$5.98, LM 2559\* \$4.98.

Gould's sound provides the music of Messrs. Kern and Porter with lush, exciting effects. His use of only cellos and violas on *Can I Forget You?* and *All the Things You Are* is particularly engaging. Well-spread stereo. S. G.

Ⓜ AL JOLSON: *Al Jolson with Oscar Levant at the Piano*. Al Jolson (vocals); Oscar Levant (piano). *In the Good Old Summertime*; *Ramona*; *Poor Butterfly*; and eighteen others. DECCA DL 9095 \$4.98.

Jolson and Levant would never win any awards for the quality of their humor on these old Kraft Music Hall broadcasts, but they do achieve a winning air of informality and spontaneity. A remarkable recording. S. G.

Ⓢ Ⓜ JACK JONES: *This Was My Love*. Jack Jones (vocals); orchestra, Pete King cond. *Lollipops and Roses*; *Love Letters*; *My Romance*; and seven others. KAPP KS 3259 \$4.98, KL 1159\* \$3.98.

Jack Jones has a pleasantly bland approach and projects romantic sentiments with a maximum of sincerity and a minimum of hoke. The attractive program includes a folk-type song called *Julie* that has special appeal. Tasteful stereo quality. S. G.

Ⓢ Ⓜ KING OF KINGS (Miklos Rozsa). Symphony Orchestra of Rome and the Singers of the Roman Basilicas. Miklos Rozsa cond. MGM S 1E2\* \$7.95, 1E2 \$6.95.

This work covers the same period of history as *Ben-Hur*, Rozsa's previous work, and is similarly reverential, with Hebraic and military themes underscoring the conflict. A choir is in evidence throughout. Acceptable recording. N. H.

Ⓢ Ⓜ LOS MACARENOS: *Cuadro Flamenco!* Los Macarenos of Granada (vocals, guitar, dancing, castanets). *Sevillanas*; *Esperanza*; *Bulerias*; and nine others. CAPITOL ST 10301 \$4.98, T 10301\* \$3.98.

This album of flamenco music is made particularly stimulating by the dynamic collective interplay of the troupe. Manolo Sánchez, its most accomplished singer, is a master of improvised anguish, though a little more vocal presence would have been preferred. Excellent stereo. N. H.

Ⓢ Ⓜ DIMITRI PLESSAS: *Dancing on Sunday*. Orchestra, Dimitri Plessas cond. *Little Boat from Himos*; *The Flower*; *Bring Me Wine*; and nine others. UNITED ARTISTS UAS 6146\* \$4.98, UAL 3146 \$3.98.

In this recording of modern Greek dance music, Manos Hadjidakis is represented by three compositions, none of which equals his previous success, *Never On Sunday*. The insistent use of a native instrument, the *bouzoukia*, results in an inescapable sameness in the program. Satisfactory sound. S. G.

Ⓢ Ⓜ ELVIS PRESLEY: *Blue Hawaii*. Elvis Presley (vocals) with instrumental accompaniment and the Jordanaires. *Aloha Oe*; *Moonlight Swim*; *Beach Boy Blue*; and eleven others. RCA VICTOR LSP 2426 \$4.98, LPM 2426\* \$3.98.

In this collection Presley is rather appealing, though he continues to interpret lyrics with only moderate intelligence. The backgrounds on this sound-track disc are unfortunately formularized. The stereo quality is adequate. N. H.

Ⓜ JOE RINALDI: *Gaslight '61*. Joe Rinaldi Group. *Somebody Stole My Gal*; *Toot-Toot Tootsie*; *Charleston*; and twenty others. GUILD LES 1001 \$4.98.

From the atmosphere captured by the recording and an attached booklet, I managed to conclude the following: the Gaslight Club is a private club for men that keeps well-heeled members happy by serving drinks, good fellowship, and a steady stream of cornball music. Satisfactory sound. S. G.

Ⓢ Ⓜ PETE RUGOLO: *Ten Trumpets and Two Guitars*. Pete Rugolo and orchestra. *Carnival of Venice*; *Hot Lips*; *Cherry Pink and Apple Blossom White*; and nine others. MERCURY PPS 6016 \$5.98, PP 2016\* \$4.98.

There is little musical interest to these orchestrations, featuring the coupling of trumpets, flugelhorns, and electric guitars. Arranger Rugolo has outdone himself in ensuring that not a glimmer of originality, nor a memorable moment, should creep into his score. Fine stereo. N. H.

Ⓢ Ⓜ THE HUSTLER (Kenyon Hopkins). Sound-track recording. Uncredited conductor. KAPP KS 3264 \$4.98, KL 1164\* \$3.98.

Music in the modern astringent manner, with heavy accent on woodwinds and percussion. The work is unsparing in its evocation of the seamy side of life, and it may fail to sustain interest. Satisfactory stereo. S. G.



# THE SOUND OF THE AMERICAN BAND \*\* 1792-1942

## RECORDING OF SPECIAL MERIT

© ® THE CIVIL WAR—VOL I: Fort Sumter to Gettysburg. Eastman Wind Ensemble, Frederick Fennell cond.; Martin Gabel (narrator). *Band Music of the Union Troops: Hail to the Chief; Listen to the Mocking Bird; Palmyra Schottische; Hail Columbia; Freischütz Quickstep; Port Royal Galop; Nightingale Waltz; The Marseillaise; Band Music of the Confederate Troops: Dixie; Bonnie Blue Flag; Cheer Boys Cheer; Luto Quickstep; Old North State; Easter Galop; Come, Dearest, the Daylight is Gone; Maryland, My Maryland; Waltz; Old Hundredth; Field Music of Union and Confederate Troops with Fifes, Drums, and Cavalry Bugle; The Sounds of Conflict.* MERCURY LPS 2-901 two 12-inch discs \$11.96, LPS-501\* \$9.96.

Interest: Fascinating documentation  
Performance: Superb  
Recording: First-rate  
Stereo Quality: Fine

A twenty-four-page illustrated brochure accompanying this album tells the remarkable story of how Frederick Fennell went about collecting and rehabilitating the original Civil War band instruments and part books that provide the musical substance for its two most fascinating sides. These are those devoted to the patriotic songs, hymns, and dances of Union and Confederacy; and as played on the band instruments of the period, this music achieves a sweetness of sound and a poignance that is irresistible. The delightful pertness of *Listen to the Mock-*

*ing Bird*, the quaint charm of the *Palmyra Schottische* and the *Nightingale Waltz*, and the noble dignity of *Maryland, My Maryland* are nowhere nearly approximated in any other versions on or off records. We hope that Mercury will one day make these two sides available separately as a single disc, for in musical worth they belong with such other outstanding Americana on disc as Columbia's Vol. I of "American Moravian Music" (MS 6102/5427). As sheer listening entertainment, they are a joy from start to finish.

The remaining two sides of the album are of interest chiefly to the military- and historical-minded listener. The first of these is devoted to some three dozen fife-and-drum tunes and cavalry bugle calls, played with the utmost elegance and precision; and the final side is given over in the main to a recreation, with narration and authentic sound effects, of highlights of the Battle of Gettysburg. The sound effects in question were provided by actual Civil War armament recorded at Gettysburg, and their sound, especially in the Pickett's Charge sequence, is enough to satisfy even the most demanding hi-fi bug. The narrative itself, taken almost entirely from eye-witness accounts, is tellingly and tastefully delivered by Martin Gabel.

Whatever reservations one may have about the mixture of musical and military-documentary elements in this album, one cannot help but stand back in admiration over what Mr. Fennell and the Mercury staff have accomplished in this remarkable synthesis of scholarship and audio technology. *D. H.*

FREDERICK FENNEL

*A masterful recreation of the music of the Civil War*



HAROLD LAWRENCE

## RECORDING OF SPECIAL MERIT

© ® THE GOLDMAN BAND: Cavalcade of the American Band. The Goldman Band, Richard Franko Goldman cond. *Chester* (Billings); *The Battle of Trenton* (Hewitt); *The Federal March* (Reinagle); *Wood Up Quickstep* (Holloway); *Santa Ana's Retreat from Buena Vista* (Foster); *New York Light Guards Quickstep* (Brown); *American Salute* (Gould); *Washington Greys March* (Grafulla); *Presidential Polonaise* (Sousa); *President McKinley Inauguration March*; *22nd Regiment March* (Herbert); *American Patrol* (Meacham). CAPITOL SW 1688 \$5.98, W 1688\* \$4.98.

Interest: Splendid panorama  
Performance: Vital  
Recording: Good  
Stereo Quality: Effective

Richard Franko Goldman, son of the late founder of the celebrated Goldman band, has assembled a delightful and fascinating collection of American band music, including original pieces from the Federal and Jacksonian eras. William Billings' Revolutionary hymn *Chester* (1778) is a stirring thing to hear in any form, and it is beautifully set for brass in this recording. The 1792 *Battle of Trenton* opus, composed originally for piano by James Hewitt, is a typical period piece akin to Beethoven's later "Battle" Symphony. The band arrangement used here is brilliantly effective and makes the music curiously moving. Reinagle's *Federal March* (1792) is a fine bit of post-Georgian pomp and circumstance; but with the *Wood Up Quickstep* we have a bit of gloriously vital Americana. This little rarity, with its dialogue for solo cornets, is sheer delight. Another fascinating discovery is the forgotten Stephen Foster Mexican War march on *Santa Ana's Retreat*. The music on Side 2 is in the more familiar idiom of the American "manifest destiny" era. Especially delighting are the Italianisms of the *Washington Greys* by famed Civil War bandmaster, Claudio Grafulla, and Victor Herbert's amusing twist on *Hail to the Chief* in the opening of his piece for the McKinley Inaugural.

Mr. Goldman and his players come through with clean and rhythmically vital performances throughout the course of this altogether splendid album. Emphasis is placed on clarity and tonal refinement rather than wide dynamics. The Capitol sound is a bit echo-chambery in spots, but is otherwise wholly tasteful and particularly well handled from the standpoint of stereo localization. *D. H.*



## THEATER - FILMS

Ⓢ Ⓜ ALL AMERICAN (Charles Strouse-Lee Adams). Original-cast recording. Ray Bolger, Eileen Herlie, Ron Husmann, Anita Gillette, Fritz Weaver; chorus and orchestra, John Morris cond. COLUMBIA KOS 2160 \$6.98, KOL 5760\* \$5.98.

Interest: Pleasant score  
Performance: Topnotch company  
Recording: Excellent  
Stereo Quality: High

Judging from their first musical, *Bye Bye Birdie*, and from this one, song-writers Charles Strouse and Lee Adams have a particular affinity for stories that deal with the clash between the older and the younger generations. *All American* concerns the influence of a foreign-born professor on his students and their influence on him, and the score responds brightly and satirically to such a made-to-order situation.

Though the writers are young men, the special distinction they give their songs is principally in the three rather sentimental duets written for the professor and the dean of women, played by Ray Bolger and Eileen Herlie, two remarkably effective singing actors. Gracefully written, these songs are among the most charming this season.

But of course Mr. Bolger and Miss Herlie have individual opportunities to cut loose. He does it in *Pm Fascinating*, which preserves on LP some of Bolger's truly fascinating footwork. She does it in a wild, tempestuous song of seduction called *The Real Me*, which, I imagine, must be seen to be fully appreciated.

Ron Husmann, who has one of the best singing voices in the theater, is splendid in his one ballad, *I've Just Seen Her*. I was also rather taken with a satirical little item called *Have a Dream*.

Stereo is especially well used on Bolger's dance, which has him moving from speaker to speaker. Other numbers make effective use of vocal placement, both in choruses and in duets. S. G.

Ⓢ Ⓜ BING CROSBY: *Bing's Hollywood*. Bing Crosby (vocals). Songs from *Pennies from Heaven*, *Waikiki Wedding*, *Double or Nothing*, *Sing You Sinners*, *Paris Honeymoon*, *Dr. Rhythm*, *Road to Singapore*, *If I Had My Way*, *Road to Zanzibar*, *Birth of the Blues*, *Holiday Inn*, *Road to Morocco*, *Going My Way*, and others. DECCA DL 4250/DL 4264 fifteen 12-inch discs \$3.98 each.

Interest: The Crosby saga  
Performance: Masterful  
Recording: Varies with age

"Bing's Hollywood" is the most gargantuan collection of songs by Bing Crosby

ever released. Spanning the period 1934-1956, fifteen albums have been allotted to 187 songs he has sung in some 42 films. Each album has a different title and cover painting of Crosby, and, thankfully, they can be purchased individually.

Anyone who is interested in the history of movie musicals or in Crosby's contribution to that all-but-dead film art will be fascinated by this series. Since none of the material is newly recorded, it is probable that most purchasers will comb these albums for numbers to fill in gaps in their collections. As Decca has followed a fairly constant chronology, spot-checking should be easy. Pertinent information on every film represented is supplied.

Crosby's great respect for his material always shines through, and his interpretation of a lyric is at all times on a par with his interpretation of a melody. Happily, a high percentage of the selections are deserving of respect. Crosby's favorite lyricist, Johnny Burke, is represented by no fewer than 92 numbers, most of which reveal him to be a far more accomplished writer than his limited fame would indicate. Burke's four major collaborators, Arthur Johnson, Jimmy Monaco, Jimmy Van Heusen, and Harry Warren, also turned out some high-level work for Crosby, as did such other song writers as Robin and Rainger, Rodgers and Hart, Gordon and Revel, Irving Berlin, Arlen and Mercer, Carmichael and Loesser, and Livingston and Evans.

It is fascinating to compare the early Crosby with the Crosby of the middle Fifties. The rich, ripe, mellow tones of the mid-Thirties, so full of sincerity and exuberance, gradually acquired some gravel along the way that becomes apparent on tracks made more than twenty years later. But no matter what the period, Crosby's work is distinguished by unflinching taste, musicianship, and a knack of projection that never fails to communicate. S. G.

RUTH DRAPER: *The Art of Ruth Draper* (see p. 65).

### RECORDING OF SPECIAL MERIT

Ⓢ Ⓜ I CAN GET IT FOR YOU WHOLESALE (Harold Rome). Original-cast recording. Lillian Roth, Elliott Gould, Sheree North, Jack Kruschen, Harold Lang, Ken LeRoy, Marilyn Cooper, Barbra Streisand, Bambi Linn; chorus and orchestra, Lehman Engel cond. COLUMBIA KOS 2180 \$6.98, KOL 5780\* \$5.98.

Interest: Frequently exciting score  
Performance: Fine company  
Recording: Expert  
Stereo Quality: Very effective

Harold Rome has returned to the garment center, which spawned his first mu-

# AF AUDIO FIDELITY LIMITED TIME OFFER!

**VOLUME 2**

**STEREO**

**MORE BEST OF THE PHENOMENA DUKES OF DIXIELAND**

...YOU HAVE TO HEAR IT TO BELIEVE IT!

HIGH SOCIETY • OLL PICKLES • TROMBONEUM • LASSUS TROMBONE  
SLIDE FROG SLIDE • WASHINGTON POST MARCH • ASLEEP IN THE DEEP  
THUNDER AND BLAZES (ENTRY OF THE GLADIATORS) • SWANEE RIVER  
WITH A PACK ON MY BACK • MAPLE LEAF RAG • TA RA RA BOOM DE AY

**2.98**

MANUFACTURER'S NATIONALLY ADVERTISED PRICE  
(catalog price will be 4.98-5.95)

**MONO OR STEREO**

### MORE BEST OF THE DUKES OF DIXIELAND, VOL. 2

... Tremendous public demand for AUDIO FIDELITY's special 2.98 offer of The Best of the Dukes of Dixieland (now a collector's item) has stimulated this new release at the same low price! But ... the offer is limited! BUY NOW AND SAVE UP TO \$3.00.

Mono—AFLP 1964 • Stereo—AFSD 5964

**NEW! FREE!**

Complete catalog—fully illustrated with complete selection listings for each record—mono and stereo. Send for your copy now!

Audio Fidelity Records are produced with true Stereophonic Curtain of Sound recording technique and the highest standard in high fidelity!

AVAILABLE AT YOUR RECORD SHOP, OR WRITE TO:

AUDIO FIDELITY, INC., Dept. R7,  
770 Eleventh Ave., New York 19, N.Y.

CIRCLE NO. 8 ON READER SERVICE CARD





# Special Offer!

\* \* \* \* \*  
 \* \* \* \* \*  
 \* \* \* \* \*  
**8 issues of**  
**THEATRE ARTS**  
 \* \* \* \* \*  
**for only \$5**  
 \* \* \* \* \*

There's a delightful experience in store each month for theatre lovers who take advantage of this introductory subscription to THEATRE ARTS Magazine!

Each issue presents a *complete play* with dozens of actual on-the-scene photos. The Tenth Man... Raisin In The Sun... West Side Story... are typical examples, with many current favorites soon to come!

In addition, there are monthly *Play Reviews* by internationally-famous drama critics... the Theatre Arts Gallery, which profiles leading theatrical personalities... offbeat articles such as "Why Critics Can't Win", "Coffeehouse Theatre", "Saga Of The One-Man Show"... a host of entertaining and enlightening feature articles... and a star-studded array of pictures, from cover to cover!

The regular one-year subscription rate is \$7.50-75¢ a copy on the newsstand. But by accepting this Special Introductory Offer, you get eight big issues for only \$5. Of course, your satisfaction is fully guaranteed. Mail your order today!

\* \* \* \* \*  
**THEATRE ARTS • Dept. 762**  
**104 East 40 Street, New York 16, N. Y.**

Please enter a subscription in my name at the Introductory Rate of 8 months for \$5.

Payment enclosed.       Bill me later.

\_\_\_\_\_ initial here

name \_\_\_\_\_ please print

address \_\_\_\_\_

city \_\_\_\_\_ zone \_\_\_\_\_ state \_\_\_\_\_

sical, *Pins and Needles*, and has come up with a crackling, vital score. His musical treatments of the characters and situations of Jerome Weidman's novel have an authentic ring. Frequently using Yiddish-style instrumentations (brilliantly arranged by Sid Ramin), and with his lyrics capturing the flavor of New York's Seventh Avenue, Rome has given musical life to people for whom he is unquestionably poet laureate.

There is electricity in the air as a quintet hammers out the hard-driving, jangling ode to success, *The Sound of Money*. An irresistible gaiety saves *Momma, Momma* from mawkishness. The story of the working girl's search for Mr. Right ("Perfect he doesn't have to be") comes across in *Who Knows?* Genuine warmth and good humor shine through *The Family Way*.

These numbers, though individually attractive, are even more important as parts of the over-all design of the score. It has a unity of style and purpose apparent in almost every number, and the performances could hardly be improved. The sound is as full of life as the score, and stereo placement has been used for maximum effectiveness. S. G.

NO STRINGS (see p. 58).

## FOLK

© JOAN BAEZ, BILL WOOD, TED ALEVIZOS: *Folksingers 'Round Harvard Square*. Joan Baez, Bill Wood, Ted Alevizos (vocals and guitars). *Sail Away Ladies; Careless Love; Don't Weep after Me*; and fifteen others. VERTAS XTV 62202 \$5.95.

Interest: The first Baez on record  
 Performance: Mostly for Joan  
 Recording: Very good

Originally recorded in 1959 and released in small quantity, this cross-section of Harvard Square coffee house music has been reissued because of the subsequent high renown of one of the participants, Joan Baez. Miss Baez is heard on six solo tracks, in three duets with Bill Wood, and in one trio.

Although her singing at this point did not have quite the concentrated intensity it has in her later Vanguard sets, her performances on this record are worth having because of their singular purity of sound and stubbornly personal style which is neither fake ethnic nor hopelessly commercial. Baez admirers, incidentally, will find in this collection her only recorded solo version so far of one of her most popular interpretations, *What You Gonna Call Your Pretty Little Baby?* (also known as *Virgin Mary Had One Son*).

Bill Wood's four solos are overly eclectic. Ted Alevizos sings three ballads in a

style reminiscent of John Jacob Niles—hardly an ideal model. His one Greek song, however, presages the considerable quality of his later all-Greek albums for Tradition and Prestige. In sum, there is enough Joan Baez for the album to be recommended. N. H.

THE CLANCY BROTHERS AND TOMMY MAKEM (see p. 59).

## RECORDING OF SPECIAL MERIT

© © BOB DYLAN. Bob Dylan (vocals, guitar, harmonica). *Man of Constant Sorrow; Highway 51; See That My Grave Is Kept Clean*; and ten others. COLUMBIA CS 8579 \$4.98, CL 1779\* \$3.98.

Interest: Startling debut  
 Performance: Still developing  
 Recording: Excellent  
 Stereo Quality: Effective

Prepare yourself for what should become a major folk talent. Mr. Dylan, only twenty, comes from Minnesota but has traveled a country whose heterogeneity is vibrantly reflected in his singing. Dylan illustrates the very best of the newest generation of citybillies. He has not only studied ethnic models from Negro blues singers to white country stylists, but he is also building his own passionate, prickly style.

Dylan's approach is still quite uneven, but it is remarkably personal for so young an assimilator. He changes vocal texture (Continued on page 100)

BOB DYLAN  
*Major folk artist in the making*



HIFI/STEREO REVIEW



# HiFi / STEREO MARKET PLACE

## Global Tape Recording

### EXCHANGE HOBBY CLUB

We bring the U.S.A. and the world to you via Tape. This is the most rewarding hobby known for all ages. Tapesponding can put you in contact with people all over the world for exchanges of ideas, music, educational knowledge, or small talk. Free details.

### Write to Mailway Co.

216 W. Jackson Blvd., Chicago 6, Ill.  
or 51 W. 35th St., New York 1, New York  
or 601 S. Vermont, Los Angeles 5, Calif.  
or 2006 E. Courtland, Spokane 27, Wash.

## Quick-See Album File



### Storage cabinets available or do-it-yourself

Eliminates visibility problem of edge-stacked albums, stops jacket-bottom wear. Installs anywhere in five minutes with 4 screws. Sturdy welded steel construction, ball-bearing tracks, balanced suspension. 9 models for LP's & tape, hold to 125 albums; black or brass, \$6.95 up. Write for brochure D. Dealer inquiries invited.

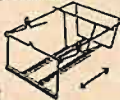

KERSTING MFG. CO., 504 S. DATE, ALHAMBRA, CALIF

## RECORDS AT COST ...

Through Our Special Membership Plan

Regular High Fidelity and Stereo

Classical—Popular—Jazz—Show Hits—Folk etc.

A unique kind of record club — No "agree to purchase" obligations — no "selected" record list to choose from — no "list price" purchases — no "division" requirements.

Simply, Citadel club members can purchase virtually any record or album, by any artist, on any label for cost price. Write for complete details . . .

### CITADEL RECORD CLUB

545 Fifth Ave. Dept. S. New York 17, N. Y.

## HI-FI RECORDING TAPE

Splice Free (except 2400')  
Freq. Resp.: 20-20,000 cps  
15 day money-back guarantee

	3-11	12-23	24+
1200' 7" acetate	\$1.29	\$1.17	99¢
1800' 7" acetate	1.79	1.59	1.45
1800' 7" mylar	1.99	1.95	1.85
2400' 7" mylar	2.69	2.59	2.49
2400' 7" tensilized mylar	2.99	2.95	2.90

Can Be Assorted. Add 15¢ Postage Per Reel. 10¢ For 24+ Lot Orders.

HI-FI COMPONENTS TAPE RECORDERS AT WHOLESALE PRICES WE SHIP WITHIN 24-48 HRS.

WE'LL AIR-MAIL LOW QUOTES ON YOUR PACKAGED HI-FI INQUIRIES.



125-Z East 88 St. New York 28, N. Y.

## RENT

### STEREO TAPES

- Over 2500 different, 4-track & 2-track
- No deposit on tapes rented
- Postpaid 2 to 5 day delivery (48 States)

FREE BROCHURE

stereo-parti  
811-B CENTINELA, INGLEWOOD, CALIF

## NATIONWIDE DELIVERY...



on all your Stereo needs. Recorders, Tuners, Amplifiers Turntables, etc. LET US PROVE that we can supply your requirements PROMPTLY AT LOWEST COST. FREE CATALOG.

STEREO COMPONENT Supply Co., Dept. S  
148-25 — 12th AVE., FLUSHING 57, N. Y.

## FM/Q ANTENNAE

THE FINEST OF ITS KIND . . .

Get more FM stations with the world's most powerful FM Yagi Antenna systems.

To be fully informed, send 30¢ for book "Theme And Variations" by L. F. B. Carini and containing FM Station Directory.



### APPARATUS DEVELOPMENT CO.

Wethersfield 9, Connecticut

## AUDIO unlimited

Specializes in

### SAVING YOU MONEY

- ✓ FACTORY FRESH COMPONENTS
- ✓ LOWEST POSSIBLE QUOTATIONS
- ✓ FAST DELIVERY

We are FRANCHISED DEALERS for most Hi-Fi lines. Most orders SHIPPED PROMPTLY from stock. RECORDING TAPE at LOWEST PRICES. FREE 95 page STEREO CATALOG.

190-S-Lex. Ave., Cor. 32 St., New York 16, N. Y. Visit Our Showroom

## TAPE RECORDERS

### HI-FI COMPONENTS

Tapes, Accessories

SLEEP LEARN KITS

Unusual Values

### MERITAPE

Low cost, high quality recording tape in boxes or cans.

FREE 1962 Catalog

DRESSNER

1523 HF Jericho Turnpike  
New Hyde Park, N. Y.

## ELECTRONIC WORLD HI-FI RECORDING TAPE

Splice Free—Guaranteed 1st Quality  
15-day Money Back Guarantee

		3-23	24+
22A	3"	225' Acetate .45	.39
60A	5"	600' Acetate .74	.67
90M	5"	900' Mylar 1.11	.99
12A	7"	1200' Acetate 1.09	.99
12M	7"	1200' Mylar 1.19	1.09
18A	7"	1800' Acetate 1.59	1.45
18M	7"	1800' Mylar 1.99	1.85
24M	7"	2400' Mylar 2.59	2.49

Add 15¢ Per Reel Postage & Handling—10¢ 24+ Reels ANY ass't. permitted For 24+ price.

Don't Buy Any Hi-Fi Components or Tape Recorders until you get our Low, Low Return Mail Quotation. Generous Trade-In on Old Equipment. WE GUARANTEE WE WILL NOT BE UNDERSOLD. Easy Pay Plan Up to 24 mos. to pay.

CATALOG AND BEST BUY LIST FREE.

### ELECTRONIC FAIR

Dept. NP—1797 1st Ave., New York 28, N. Y.

## FANTASTIC OFFER from America's

Most Unusual RECORD CLUB

50% Dividend  
Everytime you buy 2 records, you get 3rd record in same price category absolutely FREE!

- Unlimited choice, Every label, every artist
- All mono & stereo records in print
- No quotas, no fees, no obligations
- Every category — Pop, Jazz, Classical, Show, etc.
- Immediate service and delivery

Buy only what you like when you like. No obligation and no purchase requirements. Buy as few or as many records as you wish in any category. Send 35¢ in coin for new complete 250 page catalog. Deduct this amount from your first order. Small handling and mailing charge.

ALL RECORDS GUARANTEED FACTORY FRESH  
Universal Record Club  
Box 1111B, Mountainside, N. J.



HiFi/Stereo  
Market Place (Cont'd)

**LEARN WHILE YOU SLEEP**

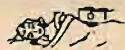

**Headquarters**

Experiment in this fascinating, educational new field. Use your phonograph, recorder or amazing new *Electronic Educator* endless tape recorder. We carry a full line of endless repeating tape cartridges for all makes of standard recorders plus automatic timers, pillow speakers and complete outfits. Also over 200 unusual educational and self-help courses on tape and record for sleep-learning and hypnosis experimenters. Write for free 300 items catalog and full astonishing details.



Sleep-Learning Research Association  
P. O. Box 24-Y, Olympia, Washington

**PROMPT DELIVERY**

**LOW PRICES**

AMPLIFIERS — MULTIPLEX —  
TAPE RECORDERS, TUNERS  
SPEAKER SYSTEMS, ETC.  
AIR MAIL QUOTES — COMPARE  
WRITE FOR CATALOG

AUDIO DIVISION

**L. M. BROWN SALES CORP**

Dept. S-242 West 10th Street • New York 14, N. Y.

**Send HiFi/Stereo Review  
Every Month**



Check one:  3 years for \$12  
 2 years for \$9     1 year for \$5  
IN THE U. S., and POSSESSIONS  
 Payment Enclosed     Bill Me

Foreign rates: Canada and Pan American Union countries, add \$1.50 per year; all other foreign countries, add \$1.00 per year.

name \_\_\_\_\_

address \_\_\_\_\_

city \_\_\_\_\_ zone \_\_\_\_\_

state \_\_\_\_\_

Mail to:

**HIFI/STEREO REVIEW**

HSR-762

434 S. Wabash Ave. Chicago 5, Ill.

and phrasing according to the nature of each song, but pervading all is a rough intensity and a steely but not bitter wit.

His scope is impressively broad. In his affection for Woody Guthrie, for one example, he has not only written a *Song to Woody* that is worthy of his friend, but he demonstrates elsewhere his skill in the "talking blues" at which Guthrie excelled. On other numbers, Dylan comes very close to the marrow of Negro blues guitar commentary. He has also absorbed the whooping harmonica style of such raw virtuosos as Sonny Terry and Walter Jacobs. There are excursions into mountain and Texas idioms, and he even takes on the vaudevillian *You're No Good*, which has become identified with Jesse Fuller. The engineering is brilliant, bringing Dylan's jagged zest into clear focus. *N. H.*

Ⓢ **THE GREENBRIAR BOYS.** John Herald (guitar and lead voice), Bob Yellin (five-string banjo and tenor voice), Ralph Rinzler (mandolin and banjo voice), Buddie Pendleton (fiddle), Jack Cook (bass). *Little Birdie; Rosie's Gone Again; Other Side of Jordan; Amelia Earhart's Last Flight; Rambling 'Round; Nine Pound Hammer*; and eight others. VANGUARD VRS 9104 \$4.98.

Interest: Postgraduate citybillies

Performance: Convincing

Recording: Excellent

This is a particularly stimulating session of Bluegrass (country music polyphonically improvised by unamplified strings). In sound and rhythms it is tangily authentic, both in the singing and in the virtuoso playing. Yet the three major players are city youngsters who have been to college (one is a physicist who specializes in microwave electronics). Herald, Yellin, and Rinzler have assistance from two Virginia-born musicians who have family roots in this music, but in essence, the Greenbriar Boys' flair for Bluegrass has been learned, not spontaneously assimilated.

Two years ago the group won the Old-Time Band Competition at the Fiddler's Convention in Union Grove, North Carolina. In their first album to themselves, they offer further evidence that it is possible for talented and sensitive city folk to adapt themselves to an initially alien music without sounding self-conscious or contrived.

Their material here is a lively mixture of traditional tunes, comic novelties, a sentimental news ballad (*Amelia Earhart's Last Flight*), and a Woody Guthrie song of the road. Completing the package are Ralph Rinzler's informative notes, which include a short history of the Bluegrass movement. The balance is judicious, and the sound is warm and bright. *N. H.*

Ⓢ **ROBIN HALL AND JIMMIE MacGREGOR:** "*Two Heids are Better than Yin!*" Robin Hall (vocals), Jimmie MacGregor (vocals, guitar, mandolin), Leon Rosselon (guitar, banjo, accordion), John Jobson (bass). *Cuttie's Waddin'; Mick McGuire; Three Craws*; and thirteen others. MONITOR MF 365 \$4.98.

Interest: Full-flavored folk songs

Performance: Unaffected

Recording: Very good

Robin Hall and Jimmie MacGregor are Scottish singers who have become widely popular in Britain in the past few years as a result of hundreds of appearances on BBC radio and television. In this bright sampling of songs from Scotland and Ireland, the team is deftly sardonic, delicate, and briskly high-spirited.

Their material is unusually diversified, and among the more unexpected pleasures are a medley of mocking Glasgow street songs and *The Ould Triangle*, an obligato to prison life from Brendan Behan's *The Quare Fellow*. Also represented in the Hall-MacGregor repertoire are Robert Burns and such contemporary sources as Jeannie Robertson and the McPeake family of Belfast. The recorded sound is live and warm, and the album grows in entertainment dividends with replaying because of durable tunes affectionately and knowingly revived. *N. H.*

**RECORDING OF SPECIAL MERIT**

Ⓢ Ⓢ **RAKHEL:** *Songs of Israel.* Rakhel Hadass (vocals), Samuel Baron (flute), David Glazer (clarinet), Seymour Barab (cello), Walter Raim (guitar), Herbert Harris (percussion), Ruth Ben-Zvi (drum). *The Song of the Shepherd; Carry Us to the Desert; Let Us Rejoice*; and twelve others. MONITOR MF(S)\* 364 \$4.98, MF 364 \$4.98.

Interest: Substantial sequel

Performance: Ardent

Recording: Very good

Rakhel Hadass is a lithe Israeli singer who is now part of the American folk-song circuit. Her first Monitor set, "Rakhel Sings Israeli, Yemenite, Greek and Ladino Songs," revealed her unusual versatility and exemplary musicianship. They're equally obvious here. She also has a wider scope of expressivity than most folk singers. In this generally fresh anthology of Israeli tunes, she explores many nuances of tenderness, contentment, determination, and untrammelled delight. Her diction is crisp, and she has a subtle and often playful sense of rhythm. The accompanying group, which includes several of the ablest classical musicians in New York, is appropriately precise and sprightly. *N. H.*



# HiFi/STEREO SHOPPING CENTER

RATE: 40¢ per word. Minimum 10 words. August issue closes June 3rd. Send order and remittance to: Martin Lincoln, HiFi/STEREO REVIEW, One Park Ave., N.Y.C. 16

## EQUIPMENT AND ACCESSORIES

WRITE for quotation on any Hi Fi components: Sound Reproduction Inc., 34 New St., Newark, N.J. Mitchell 2-6816.

DISGUSTED with "Hi" Hi-Fi Prices? Unusual Discounts On Your High Fidelity Requirements. Write: Key Electronics, 120 Liberty St., New York 6, N.Y. Cloverdale 8-4288.

PRICES? The Best! Factory-sealed Hi-Fi Components? Yes! Send for free catalog. Audion, 1038R Northern Blvd., Rostyn, N.Y.

BEFORE You Buy Receiving Tubes or Hi-Fi Components send now for your giant Free Zalytron current catalog—featuring nationally known Zalytron First Quality TV-Radio Tubes, Hi-Fi Stereo Systems, Kits Parts, etc. All priced to Save You Plenty—Why Pay More? Zalytron Tube Corp., 220 W. 42nd St., N.Y.C.

SAVE dollars on radio, TV-tubes, parts at less than manufacturer's cost. 100% guaranteed! No rebrands, pulls. Request Bargain Bulletin. United Radio, 1000-H, Newark, N.J.

COMPONENTS at lowest prices anywhere. Write for catalog. The Macalester Corporation 355 Macalester Street, St. Paul 5, Minnesota.

FREE—R.C.A., G.E., etc. tubes catalog. Discount up to 75% from list. Picture tubes at 75¢ inch up. Parts, parts kits at 1/10 original cost. Needles, tube testers, silicones, seleniums, 7" TV bench test tube—\$6.99—and more. Arcturus Electronics Corp. H.F., 502 22nd Street, Union City, New Jersey.

HiFi AMPLIFIERS, tuners, speakers, radios, telescopes, microscopes, cameras. Free Catalog. GM PhotoElectronics, 623 Gay, Knoxville 2, Tennessee.

PROFESSIONAL Electronic Projects—Organs, Timers, Computers, Industrial, etc. \$1 up. Catalog Free. Parks, Box 1665 Seattle 55, Washington.

THE Price is Right! Hi-Fi Components. J. Wright Co., 65-B Jensen St., East Brunswick, N.J.

BUY British—Buy Best! For the finest in all High Fidelity Equipment write for our quotation first. The Hi-Fi Export Specialists! Send \$1 for catalogue. When in England call and see us. Teleonic Ltd., 92 Tottenham Court Road, London, W.1. England.

WESTERN Hi Fi Fans. Are you interested in Price? Authorized Distributors of major lines. Write for Quotation Hi Fi Sales Co., 735 W. Main St., Mesa, Arizona.

AUTO Radios, FM/AM/SW—Becker, Blaupunkt, other Imported and American sets, for all cars; 20-30% discount/Square Electronics, 150-60 Northern Blvd., Flushing, N.Y.

THE Best For Less! Hand wired kit components. Dynaco, Elco, Grommes, Harmon-Kardon, Scott, etc., etc. at substantial savings. Factory standards exceeded. Also Speakers and turntables. Kitcraft, 158 6th Ave., Bklyn 17, N.Y. MA 2-6946.

DON'T buy Hi-Fi components until you get our low, low quotation. We guarantee "We will not be undersold." Easy-Pay-Plan. Send 10¢ for wholesale catalog and Best Buy Hi-Fi list. Hi-Fidelity Center, 220-HE E. 23rd St., N.Y. 10, N.Y.

SALE items—tapes—recorders—component quotations. Bayla—Box 131R—Wantagh, N.Y.

MIRACLE Hi-Fi Enclosure; construction drawings and assembly instructions, \$2.00. Kits and assembled cabinets also available. Gough & Company, Box 254, San Carlos, California.

## TAPE AND TAPE RECORDERS

TAPE recorders, Hi-Fi components, Sleep Learning Equipment, tapes, Unusual values. Free catalog. Dressner, 1523HF Jericho Turnpike, New Hyde Park, N.Y.

POPULAR Piano & Organ lessons on tape \$6.00 either tape. Write for particulars. Bob Miller Tapes, Box 132-H, Cranford, N.J.

SAVE 30% Stereo music on tape. Free bargain catalog/blank tape/recorders/norelco speakers. Saxitone, 1776 Columbia Road, Washington, D.C.

RENT Stereo Tapes—over 2,500 different—all major labels—free catalog. Stereo Part, 811-G Centinela Ave., Inglewood 3, California.

4/TR Stereo Tapes—bought, sold, rented, traded! Free Catalog/Bargain closeouts. (Columbia) 9651 Foxbury, Rivera, California.

SELF-Hypnosis. New concept teaches you quickly by tape or LP-record. Free literature. McKinley Publishers, Dept. 74, Box 3038, San Bernardino, Calif.

7" MYLAR Tapes. 2400'—\$1.99; 1800'—\$1.59. 10¢ reel postage. Free catalogue. Towers, Box 3095, Philadelphia 50.

## RECORDS

ALL Records—All labels. 33% Discount Free Information. Write—Westphal Enterprises, 525 First, Rochester, Michigan.

THE Record Collector Journal—comprehensive, valuable data, varied record mart. Introductory six issues—\$1.50. Record Research, 131 Hart, Brooklyn 6, N.Y.

ADULT Party Record & Catalog—\$1.00. Pioneer, Box #38-S Station F., Toledo 10, Ohio.

RARE 78's. Write Record-Lists, P.O. Box 2122, Riverside, California.

FIND record and tape reviews fast! Index to Reviews covers fourteen 1961 periodicals including Hi-Fi/Stereo Review. \$1.50 postpaid. Polart Index, 20115 Goulburn, Detroit 5, Michigan.

"HARD TO Get" records—all speeds. Record Exchange, 812 Seventh Avenue, New York 19, N.Y.

78 R.P.M. RECORDINGS, 1902-'50, sold. Free lists. Collections bought. E. Hirschmann, P.O.B. 155(HS), Verona, New Jersey.

LP RECORDS like new. Send 10¢ for lists. Records—Hillburn P.O., Hillburn, New York.

NEW 45RPM Records 50 cents each. Assorted titles. Send order to Dave Posey, Route 1, Charleston, Tenn.

## REPAIRS AND SERVICING

ALL Makes of Hi-Fi Speakers Repaired. Amrite, 168 W. 23 St., N.Y.C. 7, CH 3-4812.

Hi-Fi Problems solved by "The Hi-Fi Doctor" on the spot. Audio, Acoustic, Radio Engineer, Professional visits, day, evening. New York area. William Bohn, Plaza 7-8569.

NEW York's finest audio service department. Harmony House, Inc., 147 E. 76th St., N.Y.C. 21, RE 7-8766.

DIAGRAMS For Repairing Radios \$1.00. Television \$2.00. Give Make, Model. Diagram Service, Box 672E, Hartford 1, Conn.

Hi-Fi Service at low-fi cost. All makes meticulously serviced at moderate rates. Precision tuner alignment—\$5. Kit construction problems solved. I. Pollack, Westbury, N.Y. ED4-4490.

KITCRAFT. Kit experts—Dynaco specialists. See our regular ad in the Equipment and Accessories section. KITS assembled and tested by expert technicians. Factory standards. Rocket Electronics, 121 College Ave., Ithaca, N.Y.

YOUR ad in this space will be read by more than 160,000 hi-fi enthusiasts who are always on the lookout for good buys in equipment and accessories. For further information, write Martin Lincoln, Hi-Fi Stereo Review Classified Dept., One Park Avenue, New York 16, N.Y.

## WANTED

QUICKSILVER, Platinum, Silver, Gold. Ores Analyzed. Free Circular. Mercury Terminal, Norwood, Mass.

TRIGGER—W9IVJ. We Buy Shortwave Equipment For Cash. 7361 North, River Forest, Ill. Phone PR 1-8616.

FREE! New 1962 catalog of all photographic books available. For your copy, send postcard with name and address to Catalog Popular Photography Book Service, One Park Ave., New York 16, N.Y.

## MISCELLANEOUS

GOVERNMENT Surplus Receivers, Transmitters, Sniperscopes, Parabolic Reflectors, Picture Catalog 10¢. Meshna, Malden 48, Mass.

PATENT Searches, \$6.00 For free Invention Record and "Information Inventor's Need." Write: Miss Heyward, 1029 Vermont Avenue NW, Washington 5, D.C.

AUTHORS' Learn how to have your book published, promoted, distributed. FREE booklet "ZD," Vantage, 120 West 31 St., New York 1.

WRITE Martin Lincoln, Hi-Fi Stereo Review, One Park Avenue, New York 16, N.Y. for information on how to place a classified ad in this section.

## SHOPPING GUIDE CLASSIFIED

A HANDY GUIDE TO PRODUCTS AND SERVICES, NOT NECESSARILY IN THE HIGH FIDELITY FIELD, BUT OF WIDE GENERAL INTEREST.

## PHOTOGRAPHY-FILM, EQUIPMENT, SERVICES

SCIENCE Bargains—Request Free Giant Catalog "CJ"—144 pages—Astronomical Telescopes, Microscopes, Lenses, Binoculars, Kits, Parts. War surplus bargains. Edmund Scientific Co., Barrington, New Jersey.

## STAMPS AND COINS

TERRIFIC Stamp Bargains! Israel—Iceland—San Marino—plus triangle set—Plus Antigua—Borneo—Virgin—Scouts—Congo—Russia—Plus large stamp book—all four offers free—Send 10¢ for mailing cost. Empire Stamp Corporation, Dept. 22, Toronto, Canada.

SEATTLE Worlds Fair trade dollars! New uncirculated! Brilliant gold metal. Supply limited! \$1.50 each. L. Ball, Dept. A-4, 301 E. Thomas, Seattle 2, Wash.

## EDUCATIONAL OPPORTUNITIES

LEARN While Asleep, hypnotize with your recorder, phonograph, Astonishing details, sensational catalog free! Sleep-Learning Association, Box 24-2D, Olympia, Washington.

TAKE Bachelor's and Master's Degree correspondence courses from leading universities! Directory of 6,000 courses—\$2.00. College Research, North Highlands 17, California.

PHOTOGRAPHY for pleasure or profit. Learn at home. Practical basic training. Long established school. Free booklet. American School of Photography, 835 Diversey Parkway, Dept. 253B, Chicago, Illinois.

## GOVERNMENT SURPLUS

JEEPS \$278, Airplanes \$159, Boats \$7.88, Generators \$2.68, typewriters \$8.79, are typical government surplus sale prices. Buy 10,001 items wholesale, direct. Full details, 627 locations and procedure only \$1.00. Surplus, Box 177-C23, Abbottstown, Penna.

## EMPLOYMENT INFORMATION

HIGH Paying Jobs in Foreign Lands. Send \$2.00 for complete scoop! Foreign Opportunities, Box 172, Columbus 16, Ohio.

ADVERTISING sales representative, experienced in components field; for established consumer catalog. Box 111, Hi-Fi/Stereo Review, One Park Avenue, New York 16, N.Y.

## BUSINESS OPPORTUNITIES

I MADE \$40,000.00 Year by Mailorder! Helped others make money! Start with \$10.00—Free Proof. Torrey, Box 3566-N, Oklahoma City 6, Oklahoma.

ASSEMBLE Artificial Lures at home for stores. Materials supplied free. Profitable! Write: Lures, Tf, Walton Beach 1, Florida.

FREE Book "990 Successful, Little-Known Businesses." Work home! Plymouth 555R, Brooklyn 4, N.Y.

SECOND Income From Oil Can End Your Toil! Free Book and Oilfield Maps! National Petroleum, Panamerican Building-HF, Miami 32, Florida.

## MISCELLANEOUS

"HOMEBREWING, Beers, Wines." Instruction Manual \$1 (guaranteed!). Crystal's, 28BH7, Millburn, N.J. HYPNOTIZE Unnoticed, quickly, effortlessly or refund! Thousands satisfied! \$2. Timmer, Box 244, Cedarburg, Wisc.

"HYPNOTIZE—One word—One fingersnap," on stage. Satisfaction—or refund. \$2. Hypnomaster, Box 9309-E8, Chicago 90.



# HIFI/STEREO REVIEW PRODUCT INDEX

*As an additional reader service we have indicated the products advertised in this issue by classifications. If there is a specific product you are shopping for, look for its listing and turn to the pages indicated for the ads of manufacturers supplying that equipment.*

## ACCESSORIES

85

## AMPLIFICATION SYSTEMS

13, 27, 28, 66

## ANTENNAS, FM

18

## CARTRIDGES, PHONOGRAPH

3, 12

## MULTIPLEX ADAPTORS

13, 28, 66, 78

## RADIOS, PORTABLE

10

## RECORDS

7, 60, 63, 80, 89, 92, 94, 97, COVER 3

## SPEAKERS AND SPEAKER SYSTEMS

13, 16, 65, 75, 85, 89

## TAPE, RECORDING

11, 14, 67

## TAPE RECORDERS AND DECKS

17, 21, 24, 28, 87

## TONE ARMS

71, 83

## TUNERS AND TUNER AMPLIFIERS

8, 9, 13, 27, 28, 66, 75

## TURNTABLES AND CHANGERS

4, 15, COVER 4

## INDEX OF ADVERTISERS JULY 1962

READER SERVICE NO.	ADVERTISER	PAGE NO.
1	Acoustic Research, Inc. ....	4th COVER
2	Airex Radio Corp. ....	94
	Allied Radio ....	78
3	American Concertone, Inc. ....	87
38	Ampex Corp. ....	67
4	Angel Record Club ....	3rd COVER
	Apparatus Development Co. ....	99
5	Argo Records ....	80
6	Audio Devices, Inc. ....	11
7	Audio Dynamics Corp. ....	71
8	Audio Fidelity, Inc. ....	97
	Audion ....	99
	Audio Unlimited ....	99
	Barnes & Co., Inc., A.S. ....	82
9	Benjamin Electronic Sound Corp. ....	15
10	British Industries (Garrard) ....	4
	Brown Sales Corp., L.M. ....	100
11	Capitol Records, Inc. ....	63
	Carston Studios ....	99
	Citadel Record Club ....	99
12	Columbia LP Record Club ....	7
13	Concord Electronics Corp. ....	14
14	Daystrom Products Corp. ....	66
	Dressner ....	99
39	DuKane Corp. ....	89
15	Dynaco, Inc. ....	10
16	(EICO) Electronic Instr. Co., Inc. ....	28
17	Electro-Sonic Laboratories, Inc. ....	83, 85
18	Electro-Voice, Inc. ....	16
19	Finney Co., The ....	18
20	Fisher Radio Corp. ....	13
21	Grado Laboratories, Inc. ....	12
22	Great Books of the Western World. ....	2nd COVER, 1, 2
23	Harman Kardon ....	27
24	Heath Co. ....	21
25	Hi Fidelity Center ....	92, 99
	Kersting Mfg. Co. ....	99
26	Key Electronics ....	93
27	Lafayette Radio ....	85
28	London Records ....	89
	Mailway Co. ....	99
29	Rabsons—57th Street, Inc. ....	93
30	Roberts Electronics, Inc. ....	17
31	Scott, Inc., H. H. ....	8, 9
32	Sherwood Electronic Laboratories, Inc. ....	75
33	Shure Brothers, Inc. ....	3
	Sleep Learning Research Assoc. ....	100
	Stereo Component Supply Co. ....	99
	Stereo-Parti ....	99
34	Superscope, Inc. ....	24
	Theatre Arts ....	98
	Universal Record Club ....	99
35	University Loudspeakers ....	65
36	Vanguard Records ....	92
37	Westminster Recording Co., Inc. ....	60



# The Best of Two Worlds of musical entertainment



..brought to you by the **ANGEL RECORD CLUB!**

## Take 5 Albums

# Pay only \$1.00

plus a small charge for shipping services

When you become a trial member of the Angel Record Club and agree to buy as few as six future selections during the next 12 months.



EDITH PIAF

HERBERT VON KARAJAN

**760. TWO IN A GONDOLA.** Dino Olivieri conducts Venetian music aggliter with romantic violins and mandolins. Monaural only. \$3.98



**702. THE SCOTS GUARDS VOL. I.** The Regimental Band and Massed Pipes in gay marches, reels, strathspeys. Monaural only. \$4.98



**789. SIBELIUS, SYMPHONY NO. 5 and FINLANDIA.** Herbert von Karajan conducts The Philharmonia Orchestra. \$4.98; Stereo \$5.98

**709. Grieg: PIANO FROM PEER GYNT.** Sir Thomas Beecham conducts Royal Philharmonic. "Delightful!" \$4.98; Stereo \$5.98.

**737. Khachaturian: VIOLIN CONCERTO.** David Oistrakh plays, the composer conducts, in a dazzling performance. Monaural only. \$4.98



**417. FRANK SINATRA. SWINGIN' SESSION!** "The King's" favorites. Always, Paper Moon, Blue Heaven, 9 more Bosses. \$4.98; Stereo \$5.98

**753. VIENNESE DANCES #2.** The Philharmonia under Vienna-born Henry Krips plays 6 scintillating waltzes. \$4.98; Stereo \$5.98.

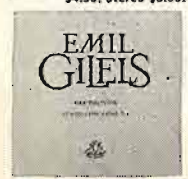

**738. Beethoven: PIANO CONCERTO NO. 4.** Russia's famed Emil Gilels is soloist with the Philharmonia Orch. \$4.98; Stereo \$5.98.

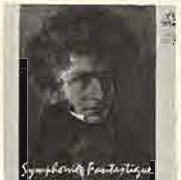

**729. Berlioz: SYMPHONIE FANTASTIQUE.** A striking interpretation by Herbert von Karajan and the Philharmonia. Monaural only. \$4.98

**361. STAN FREBERG PRESENTS THE UNITED STATES.** Dr'beat fun! Yankee Doodle Go Home plus 9 other spoofs. \$4.98; Stereo \$5.98

**773. Beethoven: PIANO CONCERTO NO. 1; SONATA NO. 27.** Solomon, piano. Herbert Meigas conducts. \$4.98; Stereo \$5.98.

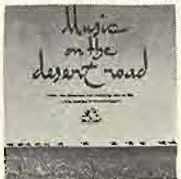

**756. MUSIC ON THE DESERT ROAD.** The haunting music of the East—14 pieces recorded on a journey to India. Monaural only. \$4.98

**776. KURT WEILL IN BERLIN.** Songs from the master tunesmith's hit shows, including Threepenny Opera. \$4.98; Stereo \$5.98

**373. THE SWINGIN' MUTUAL.** George Shearing Quintet plays—Nancy Wilson sings: Blue Lou, Inspiration, others. \$3.98; Stereo \$4.98.

**793. ENGLISH BALLETS OF THE 20TH CENTURY.** Sir Malcolm Sargent conducts Royal Philharmonic in 3 selections. \$4.98; Stereo \$5.98

**354. PEGGY LEE. BASIN STREET EAST.** Catch her club performance of Fever, Them There Eyes, Yes Indeed, 12 more. \$3.98; Stereo \$4.98



**324A & 324B. JUDY GARLAND AT CARNEGIE HALL.** Best-seller from coast to coast! Enjoy the "greatest evening in show business history". 28 exciting songs—as only Judy can sing them! \$9.98; Stereo \$11.98 2 RECORD SET COUNTS AS 2 SELECTIONS

**790. LAO. SYMPHONIE ESPAGNOLE.** OP. 21. Leonid Kogan, violin. Kyril Kondrashin in leads Philharmonia Orch. \$4.98; Stereo \$5.98



**755. APERITIFS.** The Philharmonia Orchestra in 7 vivacious French concert pieces by Berlioz, Ghabrier. \$4.98; Stereo \$5.98.

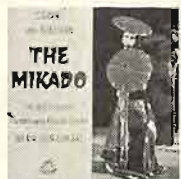

**779A & 779B. THE MIKADO** Gilbert and Sullivan. Hear the biting wit and enchanting music of the Savoyards in a brilliant new album. Sir Malcolm Sargent leads the Glyndebourne Festival Chorus and the Pro Arte Orch. \$9.98; Stereo \$11.98 2 RECORD SET COUNTS AS 2 SELECTIONS

**780. CHOPIN WALTZES.** Majczynski plays 14 delightful pieces. Minute Waltz, other favorites. \$4.98; Stereo \$5.98

**389. BEETHOVEN: VIOLIN CONCERTO IN D.** Yehudi Menuhin in a thrilling performance. Constantin Silvestri conducts. \$4.98; Stereo \$5.98



**757. GERMAN BEER-DRINKING MUSIC.** A zither, vocalists and a brass band bring frothy entertainment from Munich. Monaural only. \$3.98



**700. SOVIET ARMY CHORUS & BAND.** 200 thundering male voices sing Russian folk ballads and army songs. \$4.98; Stereo \$5.98.



**747. CALLAS PORTRAYS PUCCHINI HEROINES.** Favorite arias from operas Manon Lescaut, Butterfly, Boheme, others. Monaural only. \$4.98.

**392. MILES DAVIS. BIRTH OF THE COOL.** Also Kai Winding, J. J. Johnson, Gerry Mulligan and others in 11 "cool" tunes. Monaural only. \$3.98



**420. KINGSTON TRIO. CLOSE-UP.** 12 songs never before recorded: Sail Away, Ken Karanz, Jesse James, etc. \$3.98; Stereo \$4.98



**791. PETER SELLERS & SOFIA LOREN.** Love and wit by England's dizziest and Italy's loveliest. \$4.98; Stereo \$5.98



**794. BARTOK: Music for Strings, Percussion, Celesta; HINDEMITH: "Mathis der Maler" Symphony.** \$4.98; Stereo \$5.98



**422. LAURINDO ALMEIDA. REVERIE FOR SPANISH GUITARS.** 11 classical works by Ravel, Debussy, Tchaikovsky, others. \$4.98; Stereo \$5.98

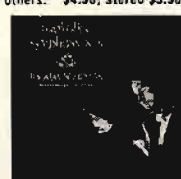

**736. Mozart: 4 HORN CONCERTOS.** Flawlessly performed by Dennis Brain with the Philharmonia Orchestra. Monaural only. \$4.98

**733. Prokofiev: SYMPHONY NO. 5.** A stunning rendition of a heroic work by Thomas Schippers with Philharmonia Orch. \$4.98; Stereo \$5.98.



**368. NAT KING COLE. THE TOUCH OF YOUR LIPS.** Not So Long Ago, I Remember You, Illusion, Funny, 8 more. \$4.98; Stereo \$5.98



**759. PIAF. 12 ballads in the poignant style of France's greatest torch singer,** with Robert Chouvin's orchestra. Monaural only. \$3.98

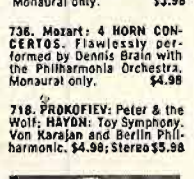

**718. PROKOFIEV: Peter & the Wolf; HAYDN: Toy Symphony.** Von Karajan and Berlin Philharmonic. \$4.98; Stereo \$5.98



**795. THE FABULOUS VICTORIA DE LOS ANGELES.** 19 songs by the world's most gifted soprano. \$4.98; Stereo \$5.98

If you wish, choose any of these GREAT RECORDINGS OF THE CENTURY by CASALS, LANDOWSKA, KREISLER, MELBA and LEHMANN. Priceless performances—on silken-smooth discs.

- 782. BAME NELLIE MELBA. Operatic & Song Recital; Matinata, Goodbye, other songs and arias from La Bohème, Lucia, Rigoletto, Roméo et Juliette, others. \$5.98
- 783. LOTTE LEHMANN. Arias from Der Freischütz, Fidelio, The Merry Wives of Windsor, Die Fledermaus, 4 others. \$5.98
- 784. PABLO CASALS. J. S. Bach: Suites for Unaccompanied Violoncello; No. 3 in C major; No. 4 in E flat major. \$5.98

- 785. WANDA LANDOWSKA. J. S. Bach: Italian Concerto; Chromatic Fantasia and Fugue; Partita in B flat major; Toccata and Fugue in D major. \$5.98
- 786. FRITZ KREISLER. Beethoven: Violin Concerto in D major, Op. 61. London Philharmonic under Barbrirolli. \$5.98
- 787. FRITZ KREISLER. Brahms: Violin Concerto in D major, Op. 77. London Philharmonic under Barbrirolli. \$5.98

Great Recordings of the Century available in Monaural only.

### HOW THE CLUB OPERATES

If collecting and listening to records is an important part of your life, the Angel Record Club can be of real service to you. For this Club offers you the best of two worlds of musical entertainment—through just one money-saving membership.

You can enjoy, for example, the musical genius of Herbert Von Karajan... the guitar artistry of Laurindo Almeida... plus magical entertainers like Edith Piaf and Frank Sinatra, all made available to you from the Angel Record Club's incomparable international catalog, which includes Columbia Gramophone (of England), Pathé Marconi (of France), Capitol Records and E.M.I.'s historic HMV Label.

If you join now, we will send you any 5 albums on this page with a bill for only \$1.00, plus a small charge for shipping services. Thereafter, your only obligation is to purchase six albums from the more than 100 to be offered to you during the next twelve months, at the price of \$3.98, \$4.98 or \$5.98 depending on the record purchased, plus a small charge to cover shipping services. You pay for your albums after you receive them.

**FREE BONUS ALBUMS:** After you've purchased these 6 albums, you then choose a 12" FREE Bonus Album of your own preference every time you buy two records from the Club. Here's a wonderful way to build a superb record library at a big saving. Mail coupon to: Angel Record Club, Dept. 2087, Scranton 5, Pennsylvania.

### ANGEL RECORD CLUB Dept. 2087, Scranton 5, Pennsylvania

Please send me these 5 Albums and bill me only \$1.00 plus a small charge for shipping services.

WRITE NUMBERS IN BOXES

I agree to purchase 6 selections from the more than 100 to be offered during the next twelve months, at the Club price, plus a small charge to cover shipping services. Thereafter, if I decide to continue membership, I will receive a 12" Bonus Album of my choice FREE for every two records I buy.

**STEREO.** Check this box if you want your 5 albums and all future selections, including Bonus records, in Stereo (which must be played only on stereo equipment). Then, you will be billed \$1.00 more with your stereo membership. The Club sells stereo records for \$1.00 more than monaural.

NAME..... (Please Print)

ADDRESS.....

CITY.....ZONE.....STATE.....

CANADA: Slightly higher prices: 1184 Castlefield Avenue, Toronto. If you wish to join through an Angel Record dealer authorized to accept subscriptions, please write his name and address in the margin.

HR-7



# AR INC. *turntable*

The corporate charter of Acoustic Research, filed in the Massachusetts State House, states the purpose for which AR was founded:

"To engage in research, development and manufacture... in the field of acoustical, electronic, electrical, and mechanical engineering and devices..."

AR now introduces its first product outside of the loudspeaker field. The AR turntable cannot be used for records other than  $33\frac{1}{3}$  rpm, and its starting time is not short enough for cueing applications. Apart from these qualifications, its performance should be judged by professional standards and on an absolute basis, without consideration of price.

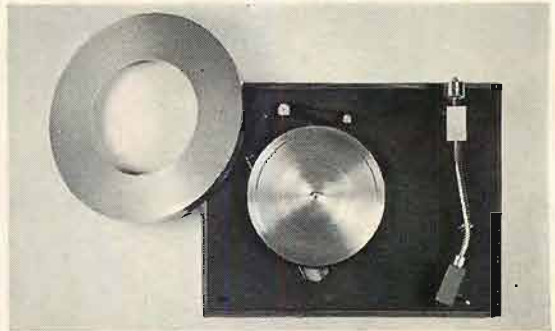

**PROFESSIONAL** quality. The AR turntable is guaranteed, as a condition of sale, to meet NAB specifications for broadcast equipment on wow, flutter, rumble, and speed accuracy. The 3.3 lb. machined, individually balanced aluminum platter is belt-driven from synchronous motors.



**STABLE** performance. The suspension design makes it possible to deal a moderate hammer blow directly to the top plate without making the needle jump grooves. This is not a recommended procedure, but it does serve to demonstrate the turntable's insensitivity to floor stomps or to acoustic feedback.



**FOR BUTTERFINGERS.** This is a picture of the tone arm a second after it has been "accidentally" dropped. It floats down to the record, yet as soon as the needle touches the groove the damping is released and the arm is freed of restraint. Needles and records are protected against predators.



**COMPLETE** (except for cartridge) including arm, cables, oiled walnut base, transparent dust cover, and even needle force gauge and overhang adjustment device. Overall dimensions with the dust cover are  $12\frac{3}{4}$ " x  $16\frac{3}{4}$ " x  $5\frac{1}{4}$ ".

The AR turntable is sold under a one-year guarantee that includes parts, labor, and reimbursement of any freight to and from the factory. It is on demonstration at dealers' showrooms and at AR Music Rooms, on the west balcony of Grand Central Terminal in New York City, and at 52 Brattle Street, Cambridge, Massachusetts. No sales are made or initiated at these showrooms.

**\$58<sup>00</sup>**  
LESS CARTRIDGE.

**ACOUSTIC RESEARCH, INC., 24 Thorndike Street, Cambridge 41, Massachusetts**