

**Dynamic Modeling of Inbreathing Requirements for Low-Pressure  
Storage Tanks**

A Thesis Presented

By

Dona Doureid Abou-Chakra

to

The Department of Chemical Engineering

In partial fulfillment of the requirements

For the degree of

Master of Science

In the field of

Chemical Engineering

Northeastern University

Boston, Massachusetts

(May 6, 2016)

## ACKNOWLEDGEMENT

This thesis would not have been accomplished without the financial support from ioMosaic Corporation©. I would like to thank Dr. Georges A. Melhem, President and CEO of ioMosaic Corporation©, for his invaluable advice and supervision throughout this project. He has set an example of excellence as a researcher, mentor, and role model.

I would like to thank my advisor, Dr. Ronald J. Willey, who always helped me make sense of any confusion and guided me through this project. His constant enthusiasm and encouragement are the reason I am where I am today.

I would like to express my gratitude to the members of my thesis committee, Dr. Behrooz Satvat and Dr. Richard West. The principles that you taught me in your classes helped me sail smoothly through this project.

I thank the entire team at ioMosaic Corporation, especially my manager Elena Prats, for being supportive of my work. A special thank you goes to Dr. Jordi Dunjó for teaching me all of the SuperChems Expert™ tips and tricks. You always had time to help me no matter how busy you were.

I would like to thank all my friends, especially Sara, Maya, and Christina, for their continuous support and for proofreading my work. You gave me the right push when I needed it the most.

Finally, the most special thank you goes to my parents and brothers for whom this thesis is dedicated to. Thank you for always believing in me and encouraging me to follow my dreams.

## ABSTRACT

Fixed roof storage tanks are known to have a weak resistance to slight vacuum or slight pressure. Typically, the minimum design vacuum is -0.036 psig and the maximum design pressure is 15 psig according to API 620 (12<sup>th</sup> Edition, 2013). Because these storage tanks have very thin shelled walls, a slight vacuum can cause tank distortion and failure. Upon a sudden change in weather conditions such as a rainstorm occurring suddenly, atmospheric storage tanks experience thermal inbreathing of ambient air into the tank. If air does not enter rapidly, a pressure drop occurs inside the tank that can lead to tank wall failure by implosion due to negative pressure. Therefore, relief devices must be sized properly based on the maximum inbreathing rate to provide safe venting of the tank.

This study aims at calculating the maximum thermal inbreathing rate by performing dynamic simulations for different tanks using ioMosaic's SuperChems Expert™ software. The first objective of this research was comparing the detailed SuperChems Expert™ single-phase and two-phase wall dynamics model to existing large scale test data and models. The results were successfully reproduced using this software with error margins between  $\pm 5\%$ . Previous to this work, the software had not been evaluated for this important modeling.

The second objective was to compare results from the SuperChems-based model against API 2000 (7<sup>th</sup> Edition, 2014), which is the current standard used for venting atmospheric and low-pressure storage tanks. This work found under a number of scenarios that API 2000 relief equations are considered conservative for non-condensable gas services where the relief device may be oversized by up to 60%. However, API 2000

modes fail to predict appropriate relief sizing for tanks storing condensable vapors, such as methanol, and wide-boiling-point mixtures, such as gasoline-ethanol. The relief device capacity can be underestimated by as much as 270% using API 2000. This work recommends adjusting the free-convection heat transfer coefficients according to the vapor type to ensure adequate relief sizing for safe venting.

The third and final objective of this research was to assess the impact of the solar radiation. Solar radiation varies with the geographical location of the tank and impacts the thermal inbreathing and out-breathing. The two locations chosen for this study were Montreal, Canada and Jubail City, Saudi Arabia. Examined were three types of colors for external wall covering with different values of emissivity. Colors examined were: white, aluminum bronze, and black. Rainstorms were simulated at the time of maximum solar flux (i.e. highest tank wall temperature) to create the worst-case scenario and thus the maximum inbreathing rate. Preliminary results for dry air showed that a 600 m<sup>3</sup> tank in Saudi Arabia experiences 10% higher inbreathing and 8% higher out-breathing as compared to a tank located in Canada. API 2000 relief calculations were adequate in this case. However, it should be noted that the comparison is for tanks filled with non-condensable dry air only. Future work in this objective is recommended for tanks containing condensable vapors and verification of the maximum inbreathing rates determined at the two locations.

# TABLE OF CONTENTS

LIST OF FIGURES .....	viii
LIST OF TABLES .....	x
1.0 INTRODUCTION .....	1
2.0 LITERATURE REVIEW .....	3
2.1. API 2000 STANDARD METHOD .....	3
2.1.1. <i>API 2000 Assumptions</i> .....	3
2.1.1.1. Assumptions for Tank Cooling.....	4
2.1.1.2. Assumptions for Tank Heating.....	5
2.1.2. <i>Normal Venting Requirements Due to Ambient Heat Transfer</i> .....	5
2.1.2.1. Thermal Inbreathing.....	6
2.1.2.2. Thermal Out-breathing.....	8
2.1.3. <i>API 2000 Annex A Method</i> .....	9
2.1.4. <i>Governing Equations from API 2000 Annex G</i> .....	10
2.2. THERMAL INBREATHING OF NON-CONDENSABLE VAPORS .....	14
2.2.1. <i>Model by Salatino et al. (1999)</i> .....	15
2.2.1.1. Salatino et al. Approach.....	15
2.2.1.2. Salatino et al. Results .....	19
2.2.1.3. Impact of Vapor Space Condensation on Thermal Inbreathing.....	22
2.2.2. <i>Model by Lloyd’s Register Energy Americas, Inc.</i> .....	22
2.2.2.1. Governing Energy Balances .....	22
2.2.2.2. LR Model Results .....	24
2.2.2.3. Impact of Tank Wall-Rain Heat Transfer Coefficient on Thermal Inbreathing .....	25
2.2.3. <i>Model by PROTEGO©</i> .....	26
2.2.3.1. Model Approach .....	27
2.2.3.2. Governing Energy Balances .....	28
2.2.3.3. Results.....	30

2.2.3.4. Proof of API 2000 Thermal Inbreathing Equation .....	31
2.3. THERMAL INBREATHING FOR TANKS CONTAINING CONDENSABLE VAPORS .....	33
2.3.1. Model by Fullarton for Tanks Containing Condensable Vapors [5] .....	33
2.3.1.1. Model Approach .....	34
2.3.1.2. Methodology .....	37
Case 1: No condensation: Naumann Formula .....	37
Case 2: No Condensation + Contribution of Tank Heat Capacity .....	37
Case 3: Condensation.....	39
2.3.1.3. Results.....	41
2.3.2. Model by PROTEGO© for Tanks Containing Condensable Vapors [8] .....	43
2.3.2.1. PROTEGO© Model of Fullarton’s Tank .....	44
2.3.2.2. Condensable Vapor Model .....	45
2.4. LARGE SCALE DATA .....	48
2.4.1. Sigel et al. Experimental Data [6].....	48
2.4.2. Holtkoetter et al. Experimental Data [7] .....	49
2.4.2.1. Experimental Setup.....	50
2.4.2.2. Results.....	51
2.5. RAIN CORRELATION AND STORM CLASSIFICATION.....	52
2.5.1. Lloyd’s Register Rain Correlation .....	52
2.5.2. Effective Rain Intensity.....	54
3.0 SUPERCHEMS-BASED MODEL SIMULATIONS .....	55
3.1. VESSELS CONTAINING TWO PHASES (DYNAMIC).....	55
3.2. VESSELS CONTAINING VAPOR (DYNAMIC) .....	56
3.3. WALL DYNAMICS .....	56
4.0 RESULTS AND DISCUSSION .....	59
4.1. SUPERCHEMS SIMULATION OF SIGEL’S RESULTS [6] .....	59
4.2. SUPERCHEMS SIMULATION OF HOLTKOETTER’S TANK.....	64
4.2.1. Simulation Results of Tank Saturated with Isopropanol .....	65

4.2.2.	<i>SuperChems Results Vs. Holtkoetter’s Model Results</i> .....	67
4.3.	SUPERCHEMS SIMULATION OF PROTEGO© MODELS .....	70
4.3.1.	<i>PRETOGO© Assumptions for Condensable Vapors</i> .....	71
4.3.2.	<i>ioMosaic© Assumptions in SuperChems Expert™</i> .....	72
4.3.3.	<i>ioMosaic SuperChems Models Versus PROTEGO©</i> .....	74
4.3.3.1.	Model Results of Tank Filled With Dry Air.....	74
4.3.3.2.	Model Results of Tank Saturated With Water Vapor.....	76
4.3.4.	<i>Examination of the Inside Heat Transfer Coefficient, <math>h_{gas}</math>, According to Vapor Type</i> .....	78
4.4.	API 2000 PERFORMANCE.....	79
4.4.1.	<i>PROTEGO© Inbreathing Model</i> .....	80
4.4.2.	<i>Large Scale Data (Sigel and Holtkoetter)</i> .....	81
4.5.	IMPACT OF THE SOLAR FLUX ON IN/OUT-BREATHING .....	82
4.5.1.	<i>SuperChems-Model Results</i> .....	82
4.5.1.1.	SuperChems Model for Montreal, Canada .....	83
4.5.1.2.	Canada versus Saudi Arabia Tank Inbreathing During a Sudden Rainstorm.....	86
4.5.2.	<i>Comparison to API 2000 Equations</i> .....	87
4.6.	IMPACT OF WIDE BOILING POINT RANGE MIXTURES.....	88
5.0	CONCLUSIONS.....	92
6.0	REFERENCES .....	94
7.0	APPENDICES .....	95
	APPENDIX A.....	96
	APPENDIX B.....	98
	APPENDIX C.....	102
	APPENDIX D.....	106
	APPENDIX E.....	110
	APPENDIX F.....	115

## LIST OF FIGURES

Figure 1: Maximum rate of temperature change; API 2000 Annex A vs. General Method [2] .....	12
Figure 2: Maximum thermal inbreathing versus Tank Volume; Model vs. Annex A [2] .....	13
Figure 3: Maximum rate of temperature change for different rain intensities [2] .....	14
Figure 4: Salatino's Tank Setup .....	16
Figure 5: Heat transfer schematic on tank wall element.....	16
Figure 6: Pressure Drop and Inbreathing Profiles [9].....	20
Figure 7: Lloyd's Model Compared to ISO 28300 [11] .....	24
Figure 8: Heat Transfer Sketch with Temperatures [8] .....	30
Figure 9: Temperature and Inbreathing Profiles – Light Rain [8].....	31
Figure 10: Schematic Of the Heat and Mass Transfer on Fullarton's Tank [5] .....	35
Figure 11: Reduction Factor ( $\eta$ ) vs. Capacity Factor (C) for Different $\alpha A/\alpha G$ [5] .....	38
Figure 12: Condensation Factor ( $\chi$ ) Vs. Capacity Factor (C) for Different $\alpha A/\alpha G$ [5]...	40
Figure 13: $V_{max}$ vs Time for Condensable Water Vapor (K=17) [5] .....	42
Figure 14: PROTEGO's Simulation of Fullarton's Water Vapor Inbreathing .....	44
Figure 15: Impact of Vapor-Space Condensation on Inbreathing [8].....	46
Figure 16: Measured Vs. Calculated Values of Inbreathing Rates [6] .....	49
Figure 17: Holtkötter Experimental Tank [7] .....	50
Figure 18: Thermal Inbreathing Profile for Water, Isopropanol, and Methanol [7].....	51
Figure 19: Rain/Wall Heat-Transfer Coefficient as A Function Of Rain Intensity .....	53
Figure 20: SuperChems Expert™ Segmentation Scheme [10].....	57
Figure 21: Heat Transfer Mechanisms for a Tank during a Rainstorm [10] .....	57
Figure 22: Backpressure Curve for a 10" Ideal Nozzle .....	60
Figure 23: Simulation of Sigel's Tank using SuperChems .....	61
Figure 24: Temperature Profile of Sigel's Tank (SuperChems) .....	62
Figure 25: Temperature Rise Rate of Gas in Sigel's Tank (SuperChems).....	62
Figure 26: Inbreathing Profile Using Sigel's "Claimed" Parameters (SuperChems) .....	63
Figure 27: Isopropanol Vapor Inbreathing Profile (SuperChems) .....	65
Figure 28: Isopropanol Vapor Temperature Profile (SuperChems) .....	66
Figure 29: Inbreathing Versus Temperature Difference – Isopropanol [7] .....	67
Figure 30: Inbreathing Profile of Isopropanol - SuperChems versus Holtkoetter Model.	68
Figure 31: Temperature Profile Isopropanol - SuperChems versus Holtkoetter model ...	69
Figure 32: $V_{max}$ as a function of $\Delta T$ for Isopropanol - SuperChems vs. Experimental ....	70
Figure 33: Vessel Segmentation in SuperChems Expert™ .....	72
Figure 34: Effect of Wall Thickness on Inbreathing (SuperChems) .....	73
Figure 35: Inbreathing Profile of Air (SuperChems).....	74
Figure 36: (a) Temperature Change Rate versus Time. (b) Temperature Difference vs. Time of Air (SuperChems) .....	75
Figure 37: Inbreathing Profile of Water Vapor (SuperChems) .....	76
Figure 38: Temperature Profile of Water Vapor (SuperChems) .....	77
Figure 39: Solar Flux Distribution for Canada using SuperChems Expert .....	83
Figure 40: Gas Temperature and Inbreathing Profile for Aluminum Bronze Tank in Montreal, Canada.....	84



Figure 41: Inbreathing Profile of Different Mixtures .....	89
Figure 42: $H_{\text{gas}}$ for pure water calculated using SuperChems.....	91

## LIST OF TABLES

Table 1: API 2000 <i>C</i> -factor for Thermal Inbreathing .....	7
Table 2: <i>Y</i> -Factor for Thermal Out-Breathing .....	8
Table 3: Annex-A Normal Venting Requirements Due To Thermal Effects [2] .....	10
Table 4: Salatino's Inbreathing Calculations Comparison Table [9] .....	21
Table 5: Impact Of Different Outside Heat-Transfer Coefficients, $h_o$ [11].....	25
Table 6: Thermal Inbreathing Equation according To Different $h_o$ Values.....	25
Table 7: Surface Area and Volume of Flat and Conical Roof Tanks .....	26
Table 8: Range of $\chi$ -factor for Different Condensable Vapors [5] .....	40
Table 9: Maximum Inbreathing Results of Fullarton's Lab Scale Experiment.....	43
Table 10: Vapor Pressure as a Function of Temperature for Different Gases.....	45
Table 11: Ratio of the Maximum Inbreathing With Condensation to Without Condensation.....	47
Table 12: Types of Rainstorms .....	52
Table 13: Adjusted Values for $H_{gas}$ for SuperChems Expert™ Two-Phase Model.....	78
Table 14: Inbreathing Requirements of PROTEGO(C)'s Tank According to API 2000..	80
Table 15: Inbreathing Requirements for the Large Scale Experiments According to API 2000 .....	81
Table 16: Maximum Inbreathing, Out-breathing, and Solar Radiation - Montreal, Canada.....	85
Table 17: Maximum Inbreathing, Out-breathing, and Solar Heat Rate - Jubail City, Saudi Arabia .....	86
Table 18: API 2000 Breathing Requirements - Canada vs. Saudi Arabia .....	87
Table 19: Gasoline Composition [13].....	88
Table 20: Saturated Mixture Molar Composition with Nitrogen Gas .....	89

## 1.0 INTRODUCTION

Atmospheric and low-pressure storage tanks are typically found in most industries like petrochemical, chemical, pharmaceutical and food industries. Because of their popular utilization, atmospheric storage tank failures represent a large fraction of total number of industrial accidents recorded. As indicated by Kletz, “No item of equipment is involved in more accidents than storage tanks, probably because they are fragile and easily damaged by slight overpressure or vacuum” [1]. This study is focused on fixed-roof storage tanks used to store hydrocarbon mixtures of low volatility i.e. compounds with vapor pressures well below atmospheric pressure.

Some disadvantages of atmospheric and low-pressure fixed-roof storage tanks are the evaporative loss of liquid and the presence of large flammable vapor space that can cause an internal explosion if a source of ignition is present. The evaporative loss of liquid can either occur during the emptying/filling operations or during a sudden change in weather or fire exposure.

Inbreathing and out-breathing “due to liquid movement” occur during tank-emptying and tank-filling operations, respectively. Thermal in/out-breathing, on the other hand, occurs when a change in the weather conditions, such as a heat wave or a summer rainstorm, takes place.

The threat of creating a vacuum occurs when the contents of the tank vapor space are suddenly cooled by a rainstorm causing the vapor space to contract and condense; therefore, rapidly decreasing the internal pressure. This pressure drop will pull outside air

(or nitrogen) into the tank's vapor space i.e. thermal inbreathing. In contrast, when the tank is exposed to fire or a heat wave, the stored liquid will start to evaporate and expand causing a pressure buildup inside the tank. The pressure build up is relieved by venting the gas to the atmosphere or a confined space. The combination of the liquid-movement and thermal effects shall be used to determine the total normal inbreathing or out-breathing flow rate.

The American Petroleum Institute (API) developed the API 2000 standard (7<sup>th</sup> edition, March 2014), called "Venting Atmospheric and Low-pressure Storage Tanks" [2], is the general design criteria for venting non/refrigerated aboveground and belowground storage tanks operating between full vacuum and 15 psig. API 2000 assumptions, however, are very conservative and often results in oversized relief devices that are costly. Therefore, alternative models for properly calculating the relief requirement, based on assumptions different from API 2000, were developed by each of Neumann [4], Fullarton [5], Sigel [6], Holtkoetter [7] and PROTEGO© [8].

The aim of this study is to dynamically model the inbreathing phenomenon experienced by fixed-roof tanks that enables the proper prediction of the required relief requirements under extreme weather conditions and generates a cost-effective yet conservative venting device. The impact of storing condensable vapors and wide-boiling-point mixtures on the predicted inbreathing rates is assessed. The impact of the solar flux at different geographical and climatic locations on the in/out-breathing is also evaluated as part of this study. All simulations are performed using ioMosaic's relief systems software, SuperChems Expert™ [10], where results are compared to large scale test data and the API 2000 design criteria.

## **2.0 LITERATURE REVIEW**

This section reviews the current standard used for storage-tank venting calculations, API 2000, as well as previous inbreathing models for both condensable and non-condensable services. In addition, a summary of the large scale experiments done for measuring the inbreathing rates is also reviewed. All simulations covered later in this thesis will be compared to the relief calculations as computed using API 2000 [2].

### **2.1. API 2000 Standard Method**

The API standard 2000 “Venting Atmospheric and Low Pressure Storage Tanks” covers the venting requirements due to liquid movement, thermal effects, and fire exposure (or emergency venting) for fixed-roof liquid storage tanks. This standard excludes floating-roof tanks and refrigerated tanks. The low-pressure tanks can have a design pressure between full vacuum to 1.034 barg (15 psig). The following section will cover the API 2000 assumptions and equations used to quantify the thermal in/out-breathing of storage tanks.

#### **2.1.1. API 2000 Assumptions**

Annex E in API 2000 [2] contains a shorthand version of the assumptions in addition to the boundary conditions used to estimate vent sizing, this section will discuss why each assumption exists.

Although most low pressure liquid storage tanks can contain both liquid and vapor (or inert) phases, the basis for relied sizing calculations is assumed that the tank is filled with vapor only. The latter assumption creates the most conservative approach. This is because the heat absorbed by the walls will be trapped in the walls due to the poor heat transfer between vapor-phase and the wall. Thus, this causes the wall to lose its strength and be more conducive to failure.

Low pressure storage tanks have foundations that are either supported above grade or founded deep in the soil. The standard neglects the cooling heat flux to the tank bottom due to the fact that the heat transfer resistance at the bottom is very high compared to the tank walls and top.

Storage tanks' wall thicknesses vary from anywhere between 4 mm to 20 mm, however, the minimum tank wall thickness is assumed equal to 4 mm according to DIN 4119. Having a cone-roof for low pressure storage tanks is a good engineering practice in the industry; in this case, a minimum roof angle inclination of  $15^\circ$  is assumed as a conservative value.

Finally, the emissivity of the tank wall radiation is conservatively based on data for dirty bronze aluminum paint with a value  $\varepsilon = 0.6$ .

#### ***2.1.1.1. Assumptions for Tank Cooling***

The assumptions used for the scenario of “tank cooling by rain” are found in Annex E of API 2000 [2] and are listed below:

- Tank is filled with air only.
- Initial vapor space and shell wall temperature are in thermal equilibrium at 55 °C.
- Rain temperature and intensity are constant at 15°C and 225 kg/m<sup>2</sup>h (probability of 1/100 year) respectively; rain angle is at 30° from the horizontal.
- Inside free convection heat-transfer coefficient is 5 W/m<sup>2</sup>K.
- Outside film cooling heat-transfer coefficient is 5,000 W/m<sup>2</sup>K.

### ***2.1.1.2. Assumptions for Tank Heating***

The assumptions used for the “tank heating by solar radiation” scenario are found in Annex E of API 2000 [2] and are listed below:

- Tank is filled with air only.
- No liquid residue in the tank that might experience vaporization.
- Initial vapor space temperature is 15°C.
- Free convection heat-transfer coefficient of both inside and outside the tank is equal to 2 W/m<sup>2</sup>K.
- Solar radiation starts and remains at its maximum value.
- Ambient temperature is constant (no specified value).

### **2.1.2. Normal Venting Requirements Due to Ambient Heat Transfer**

The tank contents are affected by the ambient conditions especially when the tank is uninsulated which is the case for most storage tanks. Heating by high solar radiation, cooling by increased wind speeds, and cooling by a sudden rainstorm or snowfall are

common scenarios that cause major out-breathing and inbreathing, respectively, of low-pressure storage tanks.

### ***2.1.2.1. Thermal Inbreathing***

Thermal inbreathing, or the movement of air (or inert gas) into the tank, occurs when the outside of a storage tank is suddenly cooled, either by an unexpected rainstorm in the summer or by a significant temperature drop in the winter. This causes the vapor space to condense/contract to a certain extent and consequently decreases the pressure inside the tank. The pressure differential will then be the driving force for thermal inbreathing. Since storage tanks have low tolerance to upsets in pressure, especially negative pressure, the hazard of tank implosion due to vacuum should be always accounted for carefully. This method uses air at normal conditions (0°C and 101.325 kPa) as the inbreathed gas. The maximum inbreathing rate,  $\dot{V}_{IT}$ , is primarily a function of tank volume, insulation, and a C-factor (found in Table 1 below) as shown in Equation below.

$$\dot{V}_{IT} = C V_{tk}^{0.7} R_i \quad (1)$$

Where:  $\dot{V}_{IT}$  = Maximum inbreathing volumetric flow rate of air at normal conditions (Nm<sup>3</sup>/h)  
C = Dimensionless factor that depends on vapor pressure, storage temperature and latitude  
 $V_{tk}$  = Tank volume (m<sup>3</sup>)  
 $R_i$  = Reduction factor for insulation (dimensionless)



**Table 1: API 2000 C-factor for Thermal Inbreathing**

Latitude, $\phi$	C-factor			
	Vapor pressure similar or below hexane		Vapor pressure higher than hexane or unknown	
	Average storage temperature ( $^{\circ}\text{C}$ )			
	< 25	$\geq 25$	< 25	$\geq 25$
$\phi < 42^{\circ}$	4	6.5	6.5	6.5
$42^{\circ} \leq \phi \leq 58^{\circ}$	3	5	5	5
$\phi > 58^{\circ}$	2.5	4	4	4

The value of  $R_i$  is equal to one if the tank is uninsulated. Equations (2), (3), and (4) are used to calculate the reduction factor for fully insulated tanks,  $R_{in}$ , partially insulated tanks,  $R_{inp}$ , and double-wall tanks  $R_c$  respectively.<sup>1</sup>

$$R_{in} = \frac{1}{1 + \frac{h \cdot l_{in}}{\lambda_{in}}} \quad (2)$$

$$R_{inp} = \frac{A_{inp}}{A_{TTS}} \cdot R_{in} + \left(1 - \frac{A_{inp}}{A_{TTS}}\right) \quad (3)$$

$$R_c = 0.25 + 0.75 \frac{A_c}{A_{TTS}} \quad (4)$$

Where:  $h$  = Inside vapor-wall heat transfer coefficient ( $\text{W}/\text{m}^2\text{K}$ )  
 $l_{in}$  = Wall thickness of the insulation (m)  
 $\lambda_{in}$  = Thermal conductivity of the insulation ( $\text{W}/\text{m}\cdot\text{K}$ )  
 $A_{in_i}$  = Insulated surface area of the tank ( $\text{m}^2$ )  
 $A_{TT}$  = Total tank surface area including shell and roof areas ( $\text{m}^2$ )  
 $A_c$  = Surface area that's not inside the tank containment ( $\text{m}^2$ )

---

<sup>1</sup> Equations are from several internal sources. Notation used matches the notation used in the original source. Definitions of unique notations used follow many equations in this thesis.

### 2.1.2.2. Thermal Out-breathing

Thermal out-breathing is defined as the movement of stored gas outside the tank due to the expansion and/or vaporization of the liquid content after a rise in the surrounding temperature. Vapor expansion and liquid vaporization will in turn cause a pressure buildup inside the tank if the venting rate is slower than the expansion/vaporization rate. The maximum thermal out-breathing is given by the following equation.

$$\dot{V}_{OT} = Y V_{tk}^{0.9} R_i \quad (5)$$

Where:  $\dot{V}_{OT}$  = Maximum out-breathing volumetric flow rate of air at normal conditions (Nm<sup>3</sup>/h)

$Y$  = Dimensionless factor that accounts for latitude

$V_{tk}$  = Tank volume (m<sup>3</sup>)

$R_i$  = Reduction factor for insulation (dimensionless)

**Table 2: Y-Factor for Thermal Out-Breathing**

Latitude, $\phi$	Y-factor
$\phi < 42^\circ$	0.32
$42^\circ \leq \phi \leq 58^\circ$	0.25
$\phi > 58^\circ$	0.2

Values for the Y-factor can be obtained from Table 2 displayed above where its dependence is mainly on the latitude of the tank location.

### 2.1.3. API 2000 Annex A Method

The method found in Annex A was used prior to 2008 and is quite different than the current sizing method for venting devices. In order to quantify the thermal inbreathing for storage tanks with volumes smaller than 3,180 m<sup>3</sup>, Annex A [2] assumes that the tank starts cooling from an initial temperature of 48.9°C and at a constant temperature rate of -56 K/h. The thermal inbreathing rate,  $\dot{V}_{IT}$  is in Nm<sup>3</sup>/h, is as follows:

$$\dot{V}_{IT} = 0.169 V_{tk} \quad (6)$$

Where:  $V_{tk}$  = Tank volume (m<sup>3</sup>)

For tank volumes equal or greater than 3,180 m<sup>3</sup>, the thermal inbreathing is limited by a constant heat flux,  $h\Delta T$  equal to 63 W/m<sup>2</sup>. The thermal inbreathing rate is as follows:

$$\dot{V}_{IT} = 0.577 A_{exp} \quad (7)$$

Where:  $A_{exp}$  = Exposed area (m<sup>2</sup>)

The method basis starts with calculating the venting rate of the largest tank, 30,000 m<sup>3</sup>, and then obtaining the maximum temperature rate, which turns out to be 28 K/h.

**Table 3: Annex-A Normal Venting Requirements Due To Thermal Effects [2]**

Tank Capacity Column 1 <sup>a</sup>	Inbreathing Column 2 <sup>b</sup>	Out-breathing	
		Column 3 <sup>c</sup>	Column 4 <sup>d</sup>
m <sup>3</sup>	Nm <sup>3</sup> /h of air	Flash Point ≥ 37.8 °C or Normal Boiling Point ≥ 149 °C Nm <sup>3</sup> /h of air	Flash Point < 37.8 °C or Normal Boiling Point < 149 °C Nm <sup>3</sup> /h of air
10	1.69	1.01	1.69
20	3.38	2.02	3.38
100	16.9	10.1	16.9
200	33.8	20.3	33.8
300	50.4	30.4	50.4
500	84.5	50.7	84.5
700	118	71.0	118
1,000	169	101	169
1,500	254	152	254
2,000	338	203	338
3,000	507	304	507
3,180	537	322	537
4,000	647	388	647
5,000	787	472	787
6,000	896	538	896
7,000	1,003	602	1,003
8,000	1,077	646	1,077
9,000	1,136	682	1,136
10,000	1,210	726	1,210
12,000	1,345	807	1,345
14,000	1,480	888	1,480
16,000	1,615	969	1,615
18,000	1,750	1,047	1,750
20,000	1,877	1,126	1,877
25,000	2,179	1,307	2,179
30,000	2,495	1,497	2,495

Table 3 summarizes the thermal normal venting requirements as found in Annex-A of API 2000 [2]. Volumes greater than 30,000 m<sup>3</sup> are outside the scope of this method. However, interpolation is allowed for Table 3 as long as the tank volumes lie between the specified volume limits of 10 m<sup>3</sup> to 30,000 m<sup>3</sup>.

**2.1.4. Governing Equations from API 2000 Annex G**

The thermal inbreathing of a tank suddenly cooled by rain can be calculated using the equation below:

$$\dot{V}_{IT} = \frac{V_{tk}}{T_0} \cdot \frac{dT}{dt} \quad (8)$$

Where:  $\dot{V}_{IT}$  = Maximum inbreathing volumetric flow rate of air at normal conditions (Nm<sup>3</sup>/h)  
 $V_{tk}$  = Tank volume (m<sup>3</sup>)  
 $T$  = Vapor space temperature (K)  
 $T_0$  = Initial vapor space temperature (K)  
 $t$  = Time (h)

The rate of temperature change of the vapor space is the key to determining the thermal inbreathing rate. The latter can be obtained by:

$$\frac{dT}{dt} = -\alpha (T - T_{wall}) \cdot \frac{1}{c_p \cdot \rho} \cdot \frac{S}{V} \quad (9)$$

Where:  $\alpha$  = Inside convective heat-transfer coefficient between vapor space and walls (W/m<sup>2</sup>K)  
 $T$  = Vapor space temperature (K)  
 $T_{wall}$  = Inside wall temperature (K)  
 $c_p$  = Constant pressure specific heat of medium (J/kgK)  
 $\rho$  = Vapor space density (kg/m<sup>3</sup>)  
 $S$  = Heat transfer area taken as the total surface area of the tank excluding the tank bottom (m<sup>2</sup>)  
 $V$  = vapor space volume or the empty tank volume (m<sup>3</sup>)

It is noticed from the above equation that in addition to the physical properties of the tank's vapor space, the surface-to-volume ( $S/V$ ) ratio of the tank is an important factor as well. Therefore, smaller tanks with higher  $S/V$  ratios will cool faster due to their higher cooling velocities  $dT/dt$  (Figure 1 and Figure 3).

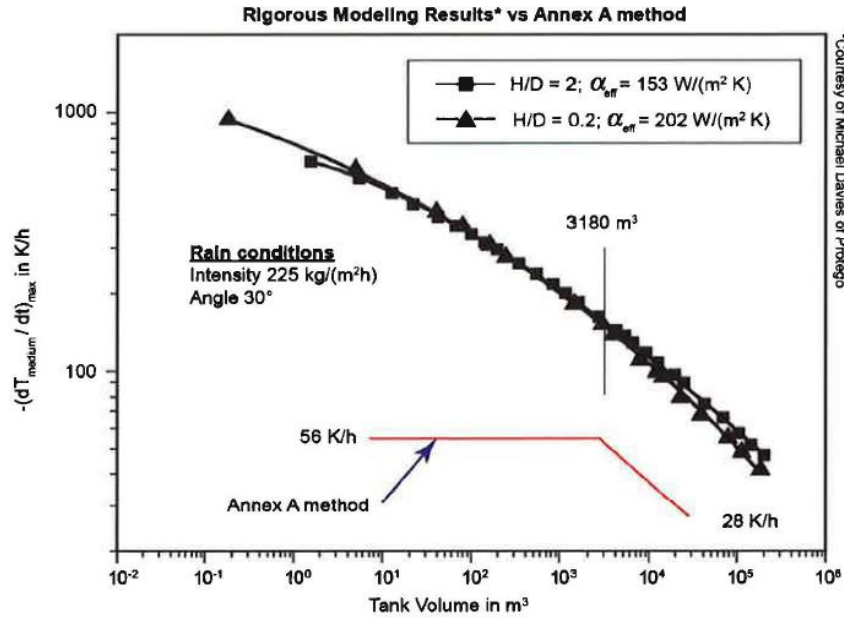

**Figure 1: Maximum rate of temperature change; API 2000 Annex A vs. General Method [2].**

Annex A assumes a constant cooling velocity of  $dT/dt = -56$  K/h for small tanks ( $< 3180$  m<sup>3</sup>) and a constant heat flux  $h\Delta T = 63$  W/m<sup>2</sup> for large tanks ( $3180 < V < 30,000$  m<sup>3</sup>). On the other hand, the general method obtains the  $dT/dt$  value from detailed thermodynamic calculations of Equations (1) and (9). The maximum rate of temperature change yields the maximum rate of thermal inbreathing. The comparison of each method's  $dT/dt$  is shown in Figure 1. The plot in Figure 2 was obtained using the data from Figure 1 and Equation (8) to show the dependence of the maximum thermal inbreathing,  $\dot{V}_{max}$ , rate on the tank volume,  $V_{tk}$ , using different methodologies. The conclusion of comparing the general method to the Annex-A method was that the rain intensity should be an order of magnitude lower, around 225 kg/m<sup>2</sup>h, for the results using the general method to agree with values in Table A.1 of API 2000's Annex A [2].

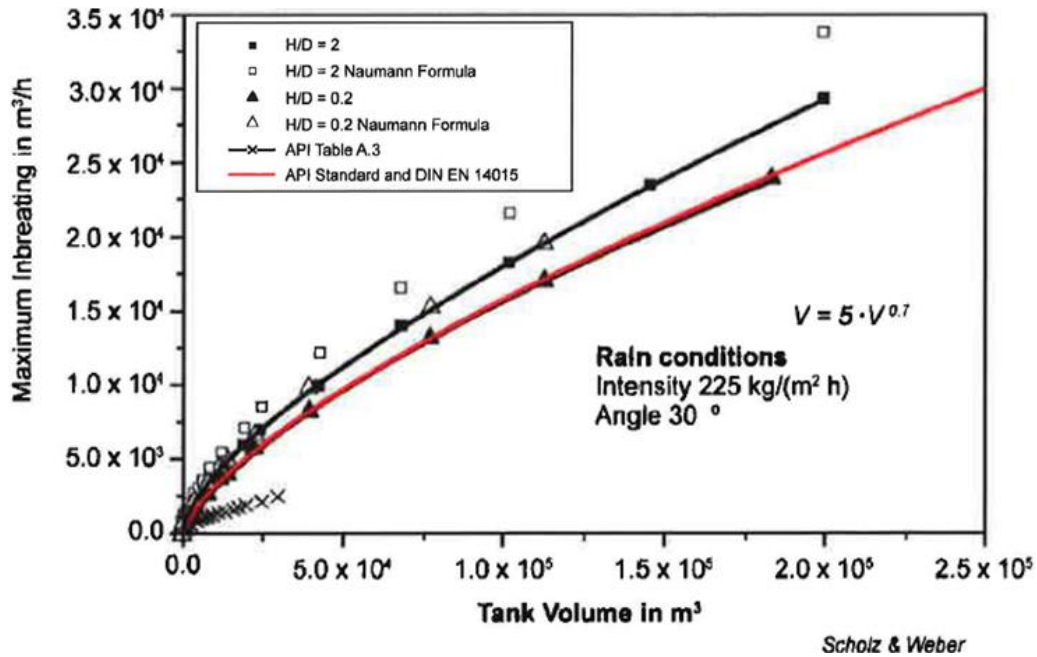

**Figure 2: Maximum thermal inbreathing versus Tank Volume; Model vs. Annex A [2].**

The rain intensity was varied to depict the various types of rainstorms that might occur and to study its effect on the cooling velocity. Low values of rain intensity represent light rainstorms such as misty rain whereas larger values represent heavier rainstorm like monsoons. Figure 3 below shows the effect of increasing the rain intensity on the rate of gas temperature change  $-dT/dt$  (Figure G.4 in Annex G - API 2000) [2].

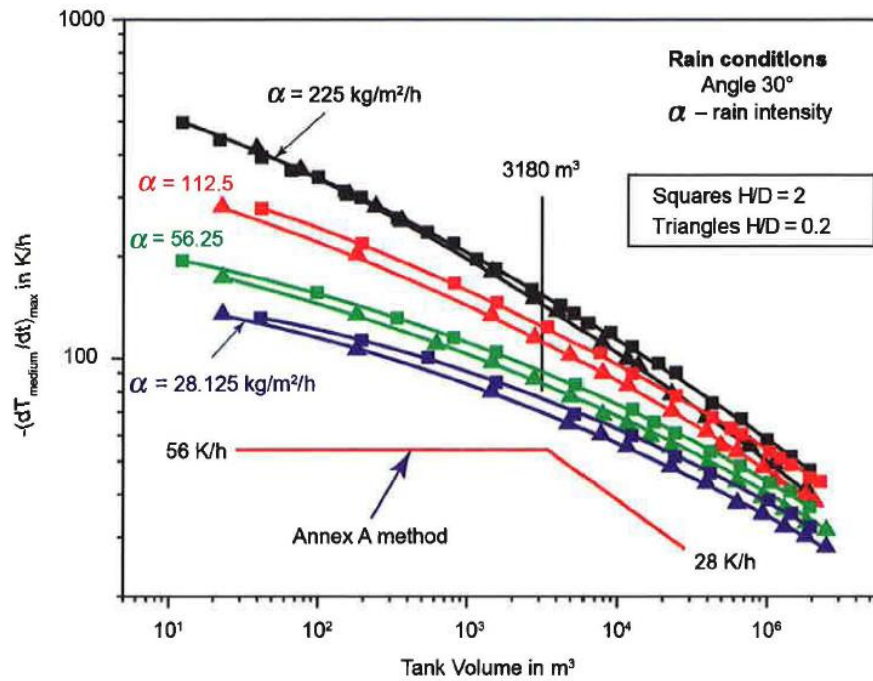

**Figure 3: Maximum Rate of Temperature Change for Different Rain Intensities [2]**

It can be seen that higher rain intensity values lead to a significant increase in the maximum cooling velocity for small tanks (volume between 20 and 3,000 m<sup>3</sup>). On the other hand, for larger tanks, increasing the rain intensity will increase the cooling velocity but with a lesser magnitude than that on the smaller tanks. Figure 3 results justify the reason behind API 2000's assumption of a rain intensity of 225 kg/m<sup>2</sup>h is the basis of their equations because this rain intensity results in the highest maximum inbreathing rate. Thus, this is considered the worst case scenario, hence, the most conservative calculation.

## **2.2. Thermal Inbreathing of Non-Condensable Vapors**

One of the major assumptions of API 2000 is that the tank experiencing inbreathing is empty (i.e. only filled with dry air) and the vapor space is considered non-condensable.



This section will review recent work on inbreathing dynamics for non-condensable dry air services only.

### **2.2.1. Model by Salatino et al. (1999)**

*Salatino et al.* [9] compare their tank inbreathing model to the older version of API 2000 (1992) that utilized the method of Annex A which is based on the maximum estimated heat loss rate of  $63 \text{ W/m}^2$  upon sudden cooling by a rainstorm of  $225 \text{ kg/m}^2\text{h}$  rain density.

They recognized that all other thermal inbreathing models assume a uniform vapor-space temperature, thus his contribution was accounting for the temperature non-uniformity inside the tank. Salatino treated the tank as two individual volumes: the shell and the roof. Salatino's model results were compared to results from API 2000, Neumann formula [9] (complete immersion assumption), PTB formulas [4].

#### ***2.2.1.1. Salatino et al. Approach***

The tank contents are at an average ambient temperature,  $T_{A,1}$ , on a hot sunny day before a rainstorm hits. The surrounding temperature rapidly decreases to a colder temperature,  $T_{A,2}$ , when a heavy rainstorm strikes (experimental time starts here at  $t = 0 \text{ s}$ ). At this point, the inside vapor-space temperature starts decreasing thus leading to a pressure decrease until the pressure/vacuum (P/V) valve set point is reached and the tank starts inbreathing ambient air at  $T_{A,2}$ .

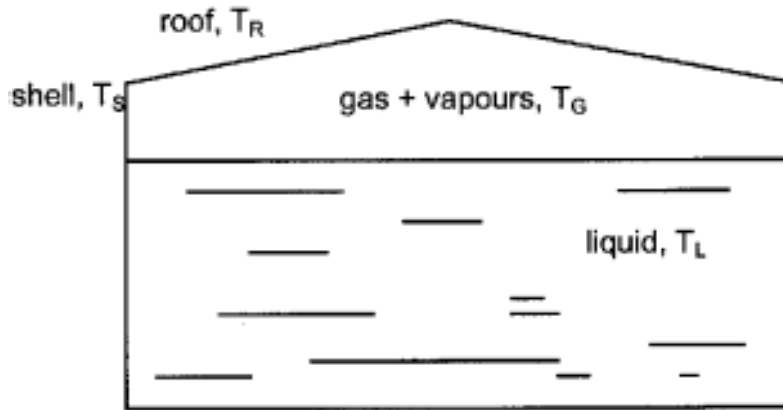

**Figure 4: Salatino's Tank Setup [9]**

As seen in Figure 4, the temperature of the roof, shell, gas, and liquid are denoted by  $T_R$ ,  $T_S$ ,  $T_G$ , and  $T_L$  respectively. Performing an energy balance on a small tank-wall element, the following ordinary differential equation, Equation (10), is obtained. This model neglects conduction along metal plates as it has a considerably small contribution to the heat transfer rate of the system.

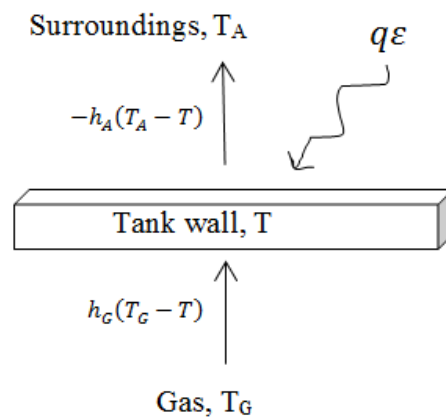

**Figure 5: Heat transfer schematic on tank wall element.**

Since the cooling takes place over the course of a day or so, then the energy accumulation term (1) of Equation (10) is neglected by assuming a pseudo-steady state process.

$$\begin{matrix} (1) & (2) & (3) & (4) & (5) \\ \rho_e c_e s \frac{dT}{dt} = & ks\nabla^2 T & + q\varepsilon & + h_A(T_A - T) & + h_G(T_G - T) \end{matrix} \quad (10)$$

Where:  $\rho_e$  = Density of the metal element (kg/m<sup>3</sup>)

$c_e$  = Heat capacity of the metal element (kJ/kgK)

$s$  = Metal element thickness (m)

$T$  = Temperature of the element (K)

$t$  = Time (s)

$k$  = Thermal conductivity of metal sheet (W/mK)

$q$  = Incident radiative flux (W/m<sup>2</sup>)

$\varepsilon$  = Surface emissivity of metal element  
(dimensionless)

$h_A$  = Heat transfer coefficient of metal element and  
ambient (W/m<sup>2</sup>K)

$T_A$  = Temperature of the ambient (K)

$h_G$  = Heat transfer coefficient of metal element and  
stored gas (W/m<sup>2</sup>K)

$T_G$  = Temperature of the stored gas (K)

Term (2), which represents the heat conduction between the metal plates of the tank, is also neglected since its contribution will be much smaller than all the other terms. Terms (3), (4), and (5) represent the heat of radiation, heat of convection to surroundings, and heat of convection from the stored gases, respectively. These terms are individually rewritten for each of the roof and the shell individually. The subscripts “R” and “S” denote the roof and shell respectively.

$$q_R \varepsilon = h_{RA}(T_{R,1} - T_{A,1}) + h_{RG}(T_{R,1} - T_{G,1}) \quad (11)$$

$$q_S \varepsilon = h_{SA}(T_{S,1} - T_{A,1}) + h_{SG}(T_{S,1} - T_{G,1}) \quad (12)$$

The last terms in Equations (11) and (12) are neglected since the convection from the tank wall to the vapor space is close to null. The energy balance on the gas inside the tank will allow for an easy method to compute the gas temperature before the cooling by rain begins:

$$T_G = \frac{\sum A_i h_{iG} T_{i,1}}{\sum A_i h_{iG}} \quad (13)$$

Where  $A_i$  = Surface area of the roof in contact with the gas (m<sup>2</sup>)

$h_{iG}$  = Heat transfer coefficients between “ $i$ ” and the gas (W/m<sup>2</sup>K)

$T_i$  = Temperature of “ $i$ ” (m<sup>2</sup>)

Subscript “ $i$ ” =  $R$  for roof;  $S$  for shell;  $L$  for liquid

Sudden cooling by rain happens at time  $t = 0$  causes the roof, shell, and gas temperatures to drop to the wet bulb temperature ( $T_{i,2}$ ). *Salatino et al.* (1999) defines the theoretical maximum attainable vacuum in the tank, assuming no condensation takes place as follows:

$$|p_2 - p_1| = p_1 \left( 1 - \frac{T_{G,2}}{T_{G,1}} \right) \quad (14)$$

Where  $p_2$  = Vapor pressure of the gas after rainstorm occurs (mm w.g.)

$p_1$  = Vapor pressure of the gas before  
rainstorm occurs (mm w.g.)

$T_{G,2}$  = Temperature of gas after  
rainstorm occurs (K)

$T_{G,1}$  = Temperature of gas before  
rainstorm occurs (K)

The volumetric flow rate, or inbreathing rate  $Q$ , is maximum at the beginning of the rainstorm i.e. at  $t = 0$ . Since  $Q$  is a function of the temperature rate  $\frac{dT_G}{dt}$ , evaluating the latter at  $t = 0$  will result the maximum inbreathing rate during a rainstorm:

$$\dot{Q}_{max} = -\frac{V}{T_G} \frac{dT_G}{dt} \Big|_{t=0} = \frac{V}{T_{G,1}} \frac{1}{\tau} (T_{G,1} - T_{G,2}) \quad (15)$$

### 2.2.1.2. *Salatino et al. Results*

A 63,000 m<sup>3</sup> empty storage tank with a 70 m diameter and 15 m height ( $H/D = 0.2$ ) is chosen for the simulation. The tank has a cone-roof setup with a roof angle of 15°. The tank is also equipped with four Pressure/Vacuum valves with a set point of -25 mm of water gauge (-0.036 psig). It should be noted that the radiative heat flux on the shell is neglected in this case and the shell temperature equals the ambient temperature. The surface areas of contact of the roof, the shell, and the liquid with the gas are  $A_R = 3900\text{m}^2$ ,  $A_S = 3200\text{m}^2$ ,  $A_L = 3800\text{m}^2$  respectively.

*Salatino et al.* (1999) used a value of 5 W/m<sup>2</sup>K for the natural-convection heat transfer coefficient between both the roof/shell and the gas when the rainstorm starts.

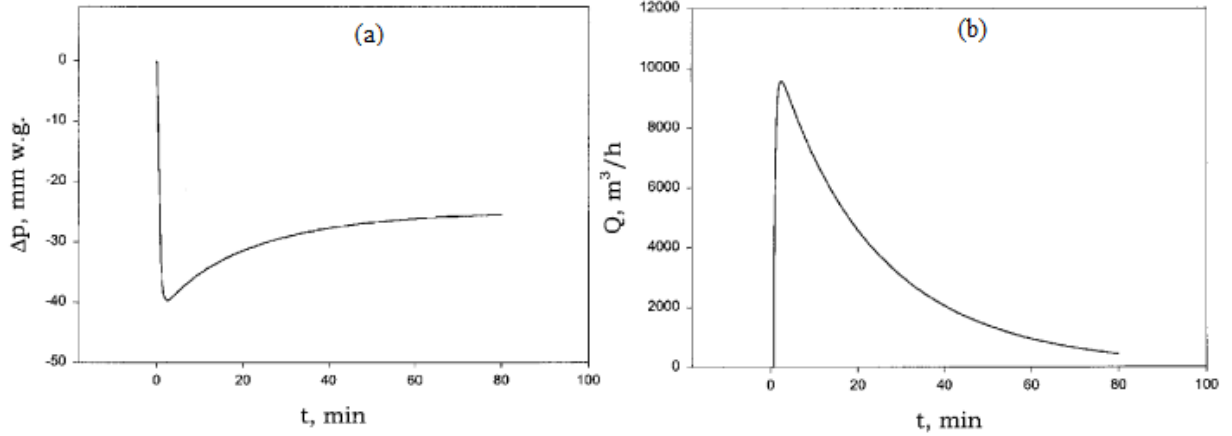

**Figure 6: Pressure Drop and Inbreathing Profiles [9]**

It can be noticed from Figure 6 that the maximum vacuum occurs at  $t = 0$  with a value of  $-40$  mm water gauge resulting in a maximum inbreathing rate of  $9600 \text{ m}^3/\text{h}$ . The heat flux corresponding to this pressure drop is  $1100 \text{ W/m}^2$  which is greater than API 2000's value of  $63 \text{ W/m}^2$  by almost two folds.

*Salatino et al.* further simplified the model by assuming an average value for the heat transfer coefficients ( $h_{RG}$ ,  $h_{SG}$ , and  $h_{LG}$ ) of  $4 \text{ W/m}^2\text{K}$  and a gas temperature drop of  $T_{G1}-T_{G2} \cong 25^\circ\text{C}$  claiming that these values will result in a conservative approximation of the inbreathing rate. Replacing these values in Equation (15) yields the simplified maximum inbreathing rate,  $\dot{Q}_{max}$ , which is a function of the tank volume,  $V$ , and the height-to-diameter ratio,  $f$ :

$$\dot{Q}_{max} = K V^{2/3} \left( \frac{1 + 2f}{\sqrt[3]{f}} \right) \quad (16)$$

Where:  $\dot{Q}_{max}$  = Maximum inbreathing rate ( $\text{m}^3/\text{h}$ )

$K$  = Constant =  $2.6 \text{ (m/h)}$

$V$  = Empty volume of the tank (m<sup>3</sup>)

$f$  = Tank height-to-diameter ratio  
(dimensionless)

The results from Salatino’s work were compared against that of API 2000’s Annex-A [2], the Neumann formula (Equation 29 in this document), the German PTB-TRbF standard (as cited in Salatino et al., 1999). Table 4 below summarizes the inbreathing requirements obtained from Salatino’s model versus other practical methodologies. It can be seen that API 2000 maximum inbreathing underpredicts the thermal inbreathing with respect to all the other methods.

**Table 4: Salatino et al. Inbreathing Calculations Comparison Table [9]**

Design Criterion	Formula	Max. Thermal inbreathing (m <sup>3</sup> /h)
API 2000 – Annex A	Table A.3 $\dot{V}_{max} \propto V_{tk}^{0.7}$	4,100
Neumann Formula	$\dot{V}_{max} \propto D^2(1 + 4f)$	12,800
PTB-TRbf Formula	$\dot{V}_{max} \propto V_{tk}^{0.71}$	11,300
Salatino - Dynamic simulation	N/A	9,600
Salatino - Equation (15)	$\dot{V}_{max} = \frac{V}{T_{G,1}} \frac{1}{\tau} (T_{G,1} - T_{G,2})$	10,000
Salatino - Equation (16)	$\dot{V}_{max} = 2.6 V^{2/3} \left( \frac{1 + 2f}{\sqrt[3]{f}} \right)$	9,900

Salatino’s calculated thermal inbreathing relief rates were between 9,600 m<sup>3</sup>/h and 10,000 m<sup>3</sup>/h which are considered more conservative than API 2000 and a little less

conservative than Neumann and PTB-TRbf formulas. The next section will cover the sensitivity analysis of different parameters.

### ***2.2.1.3. Impact of Vapor Space Condensation on Thermal Inbreathing***

*Salatino et al.* (1999) considered water vapor as the only condensable species in the tank. The maximum dew point considered was  $T_L = 25^\circ\text{C}$  and the water vapor cooled to  $T_{G,2} = 21^\circ\text{C}$ . Their assumption was that condensation accounted for a maximum of 10% of the total inbreathing demand.

Condensable gases enhances the heat transfer between the gas and the tank wall due to condensation happening at the wall, so the heat transfer coefficient ( $h_{RG}$ ,  $h_{SG}$ ,  $h_{LG}$ ) will increase, therefore  $\dot{Q}_{max}$  from Equation (15) will increase as well. No simulation was done on condensable vapor spaces and the analogy was just qualitative.

### **2.2.2. Model by Lloyd's Register Energy Americas, Inc.**

Lloyd's Register (LR) Energy Americas, Inc. analytically solved the heat balances of a storage tank that is suddenly cooled by rain [11] and compared their results against ISO 28300, which is an equivalent of API 2000 6<sup>th</sup> edition. The assumptions used in this method are the same as those of the ISO 28300.

#### ***2.2.2.1. Governing Energy Balances***

LR solved the heat balances for two control volumes: the tank's vapor space in Equation (17) and the tank walls in Equation (18):



$$m_G C_{pG} \frac{dT_G}{d\theta} = -h_G A_G (T_G - T_W) \quad (17)$$

$$m_W C_{pW} \frac{dT_W}{d\theta} = h_G A_G (T_G - T_W) - h_W A_W (T_W - T_A) \quad (18)$$

Where  $m_i$  = Mass of the medium “ $i$ ” (kg)

$C_{pi}$  = Constant-pressure heat capacity of the medium  
“ $i$ ” (kJ/kgK)

$T_i$  = Temperature of the medium “ $i$ ” (K)

$\theta$  = Time (s)

$h_i$  = Heat transfer coefficient of the medium “ $i$ ”  
(W/m<sup>2</sup>K)

$A_i$  = Heat transfer area of the medium “ $i$ ” (m<sup>2</sup>)

Subscript  $i$  =  $G$  for gas;  $W$  for wall;  $A$  for ambient

The solution of the coupled differential equations for the gas and wall temperatures allowed for the calculation of the maximum thermal inbreathing rate. The latter is obtained by calculating the maximum rate of temperature drop  $(dT_G/d\theta)_{max}$ .

$$\left(\frac{dV}{d\theta}\right)_{MAX} = \frac{V_{TK}}{T_G + 273.2} \cdot \left(\frac{dT_G}{d\theta}\right)_{MAX} \quad (19)$$

$$\left(\frac{dV}{d\theta}\right)_{Air(N)} = \left(\frac{dV}{d\theta}\right)_{MAX} \left(\frac{P_{G0}}{101.325}\right) \left(\frac{273.2}{T_A + 273.2}\right)^{0.5} \quad (20)$$

Where  $V$  = Volume of the gas in the tank (m<sup>3</sup>)

$\theta$  = Time (s)

$V_{TK}$  = Empty tank volume (m<sup>3</sup>)

$T_G$  = Instantaneous gas temperature (°C)

$P_{G0}$  = Operating pressure (kPa)

$T_A$  = Ambient rain temperature (°C)

Equations (19) and (20) contain the expressions for the maximum rate of gas volume change and the maximum inbreathing rate of air at normal conditions (0°C and 101.325 kPa).

### 2.2.2.2. LR Model Results

The model is in agreement with the API 2000 thermal inbreathing method, Equation (1), with a value of 5 for the C-factor. This model tested the effects of the gas heat transfer coefficient, rain heat-transfer coefficient, and the rain intensity on the thermal inbreathing for low pressure storage tanks.

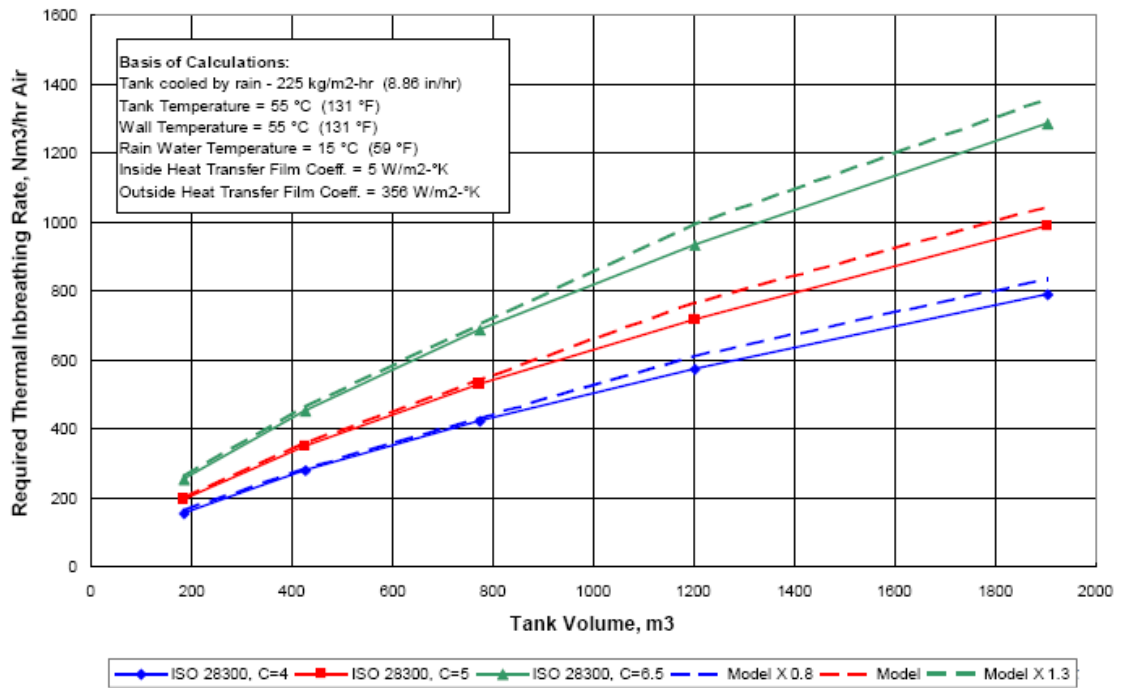

**Figure 7: Lloyd’s Model Compared to ISO 28300 [11]**

The model was then used to study the impact of several variables, some of which had minimal impact on the predicted thermal inbreathing (less than 5% error) such as the tank weight and initial gas temperature. Other variables, like the outside heat-transfer

coefficient and rain intensity, had substantial impact on the calculated thermal inbreathing rates.

### 2.2.2.3. Impact of Tank Wall-Rain Heat Transfer Coefficient on Thermal Inbreathing

LR used a value 356 W/m<sup>2</sup>K for the wall/ambient heat transfer coefficient with no indication as to why this value was chosen. Three values for of  $h_o$  were tested for five different tank sizes to assess the impact on inbreathing.

**Table 5: Impact Of Different Outside Heat-Transfer Coefficients,  $h_o$  [11]**

Case No.	Tank Volume m <sup>3</sup>	Predicted Thermal Inbreathing Rate, Nm <sup>3</sup> /hr		
		$h_o = 200 \text{ W/m}^2\text{- K}$	$h_o = 300 \text{ W/m}^2\text{- K}$	$h_o = 400 \text{ W/m}^2\text{- K}$
1	188	189.6	191.2	205.1
2	427	308.3	341.4	382.7
3	775	475.1	520.7	548.8
4	1202	678.9	740.5	778.6
5	1903	935.2	1011.6	1058.5

The results are summarized in the table above taken from the LR presentation [11]. The obtained inbreathing rates versus tank volume for different  $h_o$  values from Table 5 above were fitted with a power law model. The power-law fits are summarized in Table 6.

**Table 6: Thermal Inbreathing Equation according To Different  $h_o$  Values**

$h_o \text{ (W/m}^2\text{K)}$	Power law fit
200	$\dot{V}_{IT} = 3.554 V_{tk}^{0.7382}$
300	$\dot{V}_{IT} = 4.3823 V_{tk}^{0.7207}$
400	$\dot{V}_{IT} = 4.968 V_{tk}^{0.71}$

It can be noticed that using a 400 W/m<sup>2</sup>K rain-wall heat transfer coefficient yields the equation most similar to API 2000 (Equation (1)) with a C-factor equal to 5. This might be the justification as to why Lloyd’s Register used a value of 356 W/m<sup>2</sup>K in their model.

### 2.2.3. Model by PROTEGO©

PROTEGO© presented their model during the API 2000 Fall 2010 meeting in Los Angeles, CA; the model was a derivation of the inbreathing and out-breathing equations used in API 2000. They’ve also considered the effects of the vapor-space condensation on the venting requirements which will be covered in Section 2.3.2 of this document.

**Table 7: Surface Area and Volume of Flat and Conical Roof Tanks**

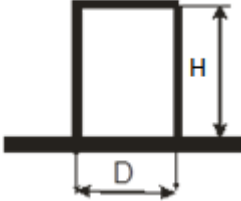
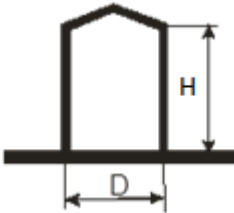
Roof Type	Sketch	Surface Area	Volume
Flat		$S = \frac{\pi D^2}{4} + \pi D H$	$V = \frac{\pi D^2}{4} \cdot H$
Conical		$S = \pi \cdot (D \cdot H + 0.25434 D^2)$	$V = \frac{\pi D^2}{4} \cdot H + 0.02603 D^3$

The two types of fixed-roof tanks that are considered in this study are the flat-roof and conical-roof types. Table 7 contains the equations used to calculate the tank’s volume

and surface area according to the roof type. The aspect ratio of a storage tank, also known as height-to-diameter ratio, is referred to as “*f*” in this model.

### ***2.2.3.1. Model Approach***

Based on API 2000’s assumption of an empty tank i.e. the tank is only filled with dry air, the control volume in this model is taken as the empty tank volume. Starting from the ideal gas law, the gaseous mass going in and out of the tank is a function of pressure, volume, and temperature as show in Equation (21). Assuming that the pressure and volume remain constant, since the tank is equipped with relief devices that maintain a constant working pressure, the only variable which is time-dependent is the temperature of the gas.

$$pV = \frac{m}{M}RT; \quad m = \frac{pVM}{RT} \quad (21)$$

Where:  $p$  = Tank pressure (Pa)

$V$  = Tank volume (m<sup>3</sup>)

$m$  = Mass of gas inside the tank (g)

$M$  = Molar mass of the gas (g/mol)

$R$  = Universal gas constant = 8.314  
(Pa m<sup>3</sup>/mol K)

$T$  = Gas temperature (K)

Differentiating mass with time and using Equation (21) one obtains:

$$\frac{dm(T, t)}{dt} = -\frac{m(T, t)}{T(t)} \cdot \frac{dT}{dt} \quad (22)$$

Assuming that the inbreathed air does not alter the density of the stored gas and since the inbreathed air has a relatively low volume compared to that of the tank's vapor space, one can use the definition of density to obtain the mass of the vapor space as follows:

$$m_{medium} = \rho_{medium} V_{tank} \quad (23)$$

Where:  $\rho_{medium} = \text{Gas density (kg/m}^3\text{)}$

Combining Equations (22) and (23), the inbreathing rate of the tank's vapor space is then obtained:

$$\frac{dV(T, t)}{dt} = \frac{V_{tank}}{T_{medium}(t)} \cdot \frac{dT_{medium}(t)}{dt} \quad (24)$$

Therefore, the maximum inbreathing rate corresponds to the maximum value of  $\left(1/T_{medium}(t) \cdot dT_{medium}(t)/dt\right)$  that can be found by solving the energy balances of the system. The solution was obtained by performing energy balances on the stored gas, the tank walls, and on the rainwater film. The differential equation and its solution are not included in this document but can be found in PROTEGO's presentation [8].

### **2.2.3.2. Governing Energy Balances**

*Scholz and Weber* [8] used a lumped capacitance heat transfer model approach to solve for the time-dependent gas temperature. The lumped-capacitance model assumes a uniform temperature in each lump. Figure 8 shows a sketch of the heat transfer mechanisms taking place during a rainstorm. The subscripts "B", "E", "W", and "surr" stand for gas, inner tank wall, water film, and surroundings respectively. The following equations summarize

the energy balances used to determine and solve the differential equations that yield the solution of the time-dependent gas temperature. The energy balance on the:

- Gas

$$\rho_B c_B V_B \frac{dT_B}{dt} = -\alpha_B F (T_B - T_E) \quad (25)$$

- Tank Wall

$$\rho_E c_E V_E \frac{dT_E}{dt} = \alpha_B F (T_B - T_E) - \alpha_W F (T_E - T_W) \quad (26)$$

- Rainwater film

$$\begin{aligned} \rho_W c_W d_W F \frac{dT_W}{dt} &= \alpha_{surr} F (T_W - T_{surr}) + \alpha_W F (T_E - T_W) \\ &- \dot{m}_{eff} c_w (T_w - T_{w,surr}) - F \cdot \text{Evaporation} \end{aligned} \quad (27)$$

Where:  $\rho$  = Density (kg/m<sup>3</sup>)

$c$  = Heat capacity (kJ/kg K)

$V$  = Volume (m<sup>3</sup>)

$T$  = Temperature (K)

$\alpha$  = Heat transfer coefficient (W/m<sup>2</sup>K)

$F$  = Area of heat transfer (m<sup>2</sup>)

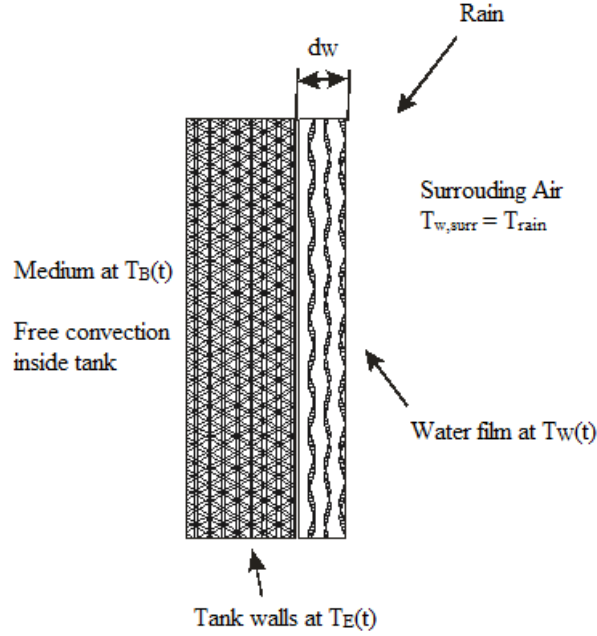

**Figure 8: Heat Transfer Sketch  
with Temperatures [8].**

It should be noted that the evaporative cooling, caused by heat supplied by the metal walls to vaporize the rain water film (Equation (27)), was considered for the rain film. Scholz and Weber (2011) introduced a new variable ( $\theta = T_B - T_W$ ), which is the difference between the gas and the wall temperature, to establish and solve the ordinary differential equation of this system. The gas temperature has an inverse exponential dependence on time and is of the form ( $\xi$ ,  $a$ , and  $b$  are constants of integration):

$$\theta(t) = \frac{(T_B - T_W)_0}{2\xi} \left[ (a + \xi)e^{\left(\frac{-a+\xi}{2}\right)t} - (a - \xi)e^{\left(\frac{-a-\xi}{2}\right)t} \right] \quad (28)$$

### 2.2.3.3. Results

Scholz and Weber (2011) compared their results with PTB [4] and proved good agreement of their model's results with the published data. First simulation was on a



conical-roof storage tank of 3,978 m<sup>3</sup> volume (S/V = 0.27) and 20 m diameter (H/D = 0.6). Light rain was assumed (75 kg/m<sup>2</sup>h) at 15°C with an angle of 60° with vertical. The inside and outside convective heat-transfer coefficients were set to 5 and 37 W/m<sup>2</sup>K respectively.

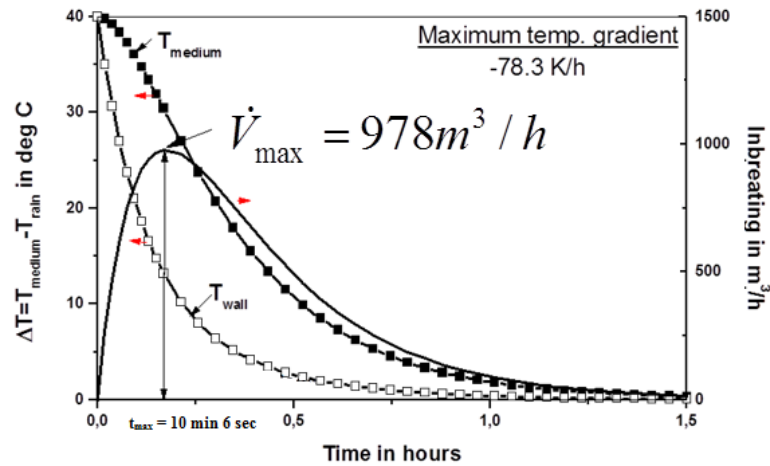

**Figure 9: Temperature and Inbreathing Profiles – Light Rain [8].**

The inbreathing and temperature profiles are summarized in Figure 9 above. The time for maximum temperature drop and thus maximum inbreathing is found to be at  $t = 10.1$  minutes from the start of the rainstorm. The maximum corresponding temperature gradient had a value of  $-78.3$  K/h thus yielding a maximum inbreathing rate of  $978$  m<sup>3</sup>/h of air.

#### ***2.2.3.4. Proof of API 2000 Thermal Inbreathing Equation***

Scholz and Weber [8] decided to prove the analogy behind Equation (1) using their model by means of simple algebraic manipulation. The Naumann Formula (as cited by Foerster, 1984) which is based on the assumption of a fully immersed storage tank was

used as a limiting case in this model and calculates the maximum inbreathing rate  $\dot{V}_{max}$  as follows:

$$\dot{V}_{max} = \frac{F \alpha_B}{\rho_B c_B} \cdot \frac{T_{B0} - T_W}{T_{B0}} = 1.5D(D + 4H) \quad (29)$$

Where  $\dot{V}_{max}$  = Maximum thermal inbreathing (m<sup>3</sup>/h)  
 $\rho_B$  = Density of the gas at T<sub>B0</sub> = 1.09 kg/m<sup>3</sup>  
 $c_B$  = Gas heat capacity = 1.01 kJ/kgK  
 $F$  = Heat transfer area of a flat roof tank  
 $\alpha_B$  = Inside heat-transfer coefficient = 5W/m<sup>2</sup>K  
 $T_{B0}$  = Initial gas temperature = 55°C  
 $T_W$  = Initial wall temperature = 15°C

Constant values for each parameter were used to simplify the expression in Equation (29) to a function of only diameter and height. The diameter,  $D$ , and height,  $H$ , were expressed as a function of the aspect ratio,  $f = H/D$ , in the following equations

$$V = \frac{\pi D^2 H}{4} = \frac{\pi D^2 (fD)}{4} \rightarrow D = \left( \frac{4V}{\pi f} \right)^{1/3} \quad (30)$$

$$H = fD = f \cdot \left( \frac{4V}{\pi f} \right)^{1/3} \quad (31)$$

Combining Equations (30) and (31) with (29), and using an aspect ratio,  $f = 2$ , and 0.2, the following equations are obtained respectively:

$$\dot{V}_{max} = 9.99V^{2/3} \text{ for } f = 2 \quad (32)$$

$$\dot{V}_{max} = 9.27V^{2/3} \text{ for } f = 0.2 \quad (33)$$

Since the aspect ratio of storage tanks doesn't exceed the value of 2, Scholz and Weber (2011) generalized the maximum inbreathing equation form where the coefficient is less than or equal to 9.99:

$$\dot{V}_{max} = Coefficient \cdot V^{2/3} \quad (34)$$

### **2.3. Thermal Inbreathing for Tanks Containing Condensable Vapors**

API 2000 neglects the possibility of vapor condensation for the thermal inbreathing/out-breathing relief calculation since only dry air is present in the tank i.e. the tank is empty. One reason to consider the effects of having condensable vapors is the steam cleaning that storage tanks undergo. Hot steam will occupy the tank after the cleaning process is complete and if a rainstorm occurs, the water vapor will condense/contract and pull a vacuum inside the tank. The next sections will cover previous work done on the thermal inbreathing of tanks storing condensable vapors.

#### **2.3.1. Model by Fullarton for Tanks Containing Condensable Vapors [5]**

*Fullarton et al.* (1986) [5] investigated and modeled the thermal inbreathing of a storage tank experiencing weather change (sudden cooling by rain) that leads to the condensation of the stored gas. The scenario defined in Fullarton's work is a sudden rainfall that cools a storage tank in the summer after being heated all day by strong solar radiation.

The motivation behind his research was to solidify the effects of condensation on tank inbreathing since results from literature had a discrepancy on this regard. The general equation for thermal inbreathing is given by:

$$\dot{V} = \frac{V_G}{T_G} \left| \frac{dT_G}{dt} \right| + \frac{\dot{M}_G}{\rho_G} \quad (35)$$

Where:  $\dot{V}$  = Thermal inbreathing (m<sup>3</sup>/h)

$V_G$  = Volume occupied by the gas  
(m<sup>3</sup>)

$T_G$  = Temperature of the gas (K)

$t$  = Time (h)

$\dot{M}_G$  = Condensation rate of the gas  
(kg/h)

$\rho_G$  = Density of the gas at  $T_G$   
(kg/m<sup>3</sup>)

Once the temperature profile of the gas is obtained as a function of time, Equation (35) is then directly used to calculate the maximum thermal inbreathing rate at the time when  $dT_G/dt$  is maximum.

### ***2.3.1.1. Model Approach***

Figure 10 below shows the different heat and mass transfer mechanisms happening on the tank after a change in weather has occurred. The tank is assumed to start cooling from an initial gas temperature,  $T_{G0}$ , of 55°C with the exposure to rain at temperature  $T_A = 15^\circ\text{C}$ . The ambient temperature is assumed to be constant and equal to the rain temperature. The rainwater film temperature is assumed equal to the tank wall based on the fact that the heat transfer rate from tank wall to the rain film is much greater than the heat transfer rate from the rain film to the surroundings.

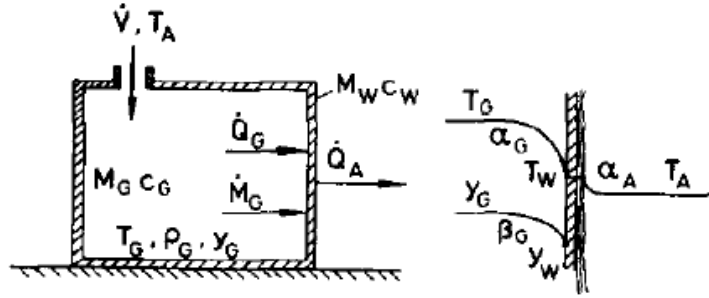

**Figure 10: Schematic Of the Heat and Mass Transfer on Fullarton's Tank [5].**

An energy balance on the gas and the tank wall, with respective subscripts “G” and “W”, is performed:<sup>2</sup>

$$M_G c_G \frac{dT_G}{dt} = -\dot{Q}_G = -\alpha_G A (T_G - T_W) \quad (36)$$

$$\begin{aligned} M_W c_W \frac{dT_W}{dt} &= \dot{Q}_G - \dot{Q}_A + \dot{M}_G \Delta h_V \\ &= \alpha_G A (T_G - T_W) - \alpha_A A (T_W - T_A) + \rho_G \beta_G A (y_G - y_W) \Delta h_V \end{aligned} \quad (37)$$

Where:  $M$  = Mass (kg)

$c$  = Constant pressure heat capacity (kJ/kgK)

$\dot{Q}_G$  = Convective heat transfer from the gas to the tank walls (W)

$\dot{Q}_A$  = Convective heat transfer rate from the tank wall to the ambient (W)

$\alpha_G$  = Convective heat transfer coefficient of stored gas (W/m<sup>2</sup>K)

$\alpha_A$  = Convective heat transfer coefficient of rain (W/m<sup>2</sup>K)

$\beta_G$  = Mass transfer coefficient (m/s)

<sup>2</sup> Notation is as reported by Fullarton et al. (1983) [5]

$y_G$  = Mass fraction of the gas assumed to be saturated at  $T_G$

The heat of condensation released at the wall is accounted for in Fullarton's model. It should be noted that the saturation pressure at  $T_G$  can be obtained from Antoine's equation,  $\ln(p^*)=f(T)$ , as cited by Fullarton (1986).

The inside convective heat transfer coefficient,  $\alpha_G$ , between the gas and the tank wall is taken as a constant value equal to 5 W/m<sup>2</sup>K. The mass transfer coefficient  $\beta_G$  is then obtained from  $\alpha_G$  by the following correlation:

$$\beta_G = \alpha_G / \rho_G c_G Le^{0.66} \quad (38)$$

$$Le = \frac{\kappa_G}{\delta_G} = \frac{\lambda_G}{\rho_G c_G \delta_G} \quad (39)$$

Where:  $\kappa_G$  = Thermal diffusivity of the gas (m<sup>2</sup>/s)

$\delta_G$  = Mass diffusivity of the gas (m<sup>2</sup>/s)

$\lambda_G$  = Thermal conductivity of gas (W/m K)

Fullarton defined a dimensionless temperature,  $\theta = \frac{T-T_A}{T_0-T_A}$ , and time,  $\tau = \frac{\alpha_G A}{\rho_G c_G V_G} t$ , to transform the energy balances in Equations (36) and (37) into dimensionless coupled ordinary differential equations. The detailed set of equations and solutions can be found in Fullarton's publication [5] and are not included in this document.

### 2.3.1.2. Methodology

Fullarton derived the inbreathing rate for three cases: no condensation, no condensation but with effects of heat capacity of the tank walls, and condensation of the stored gas.

#### Case 1: No condensation: Naumann Formula

In this first limiting case, the tank vapor space is assumed to be non-condensable i.e. the condensation flux  $\dot{M}_G$  in Equation (35) is zero. The assumption here is that the tank is rapidly cooled by a heavy downpour analogous to immersing the tank in a bath of rainwater at  $T_A$ . Therefore, the wall temperature approaches the rain temperature almost immediately. The maximum inbreathing rate is obtained in terms of the tank height and diameter.

$$\dot{V}_N = \frac{\alpha_G A}{\rho_G c_G} \frac{T_0 - T_A}{T_0} = 1.5D(D + 4H) \quad (40)$$

This is known as the Naumann formula that is used for designing the tank fittings since it only depends on the basic tank parameters and is cited by Foerster [4], Sigel [5], and Salatino [9].

#### Case 2: No Condensation + Contribution of Tank Heat Capacity

The tank wall temperature drops much faster than the temperature of the inside vapor space. However, a thicker metal wall can offer resistance to heat transfer. This means that the tank walls cool at a slower rate than when the wall thickness is neglected. The maximum inbreathing in this case will be lower than that predicted by Equation (40), thus

Fullarton defined the reduction factor  $\eta$  as the ratio of this case's maximum thermal inbreathing to the  $\dot{V}_N$  from the Naumann approximation in Equation (40).

$$\eta = \frac{\dot{V}_{max}}{\dot{V}_N} = \frac{\theta_{G,max}}{1 + \alpha_G/\alpha_A(C + 1)} \quad (41)$$

$$C = \frac{M_W c_W}{M_G c_G} \cong \frac{\rho_W c_W s_W}{\rho_G c_G} \frac{1 + 4f}{H} \quad (42)$$

Where  $\theta_{G,max}$  = Maximum dimensionless gas temperature

Note that Fullarton used a value of  $\theta_{G,max} = 0.85$  but did not provide any reason as to why this value was selected.

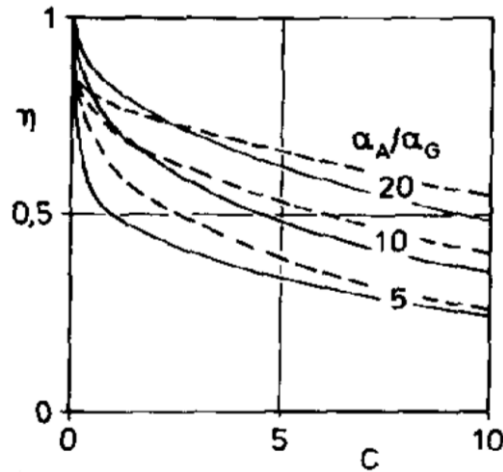

**Figure 11: Reduction Factor ( $\eta$ ) vs. Capacity Factor (C) for Different  $\alpha_A/\alpha_G$  [5].**

The graph above displays the values of  $\eta$  obtained by a numerical solution versus an approximated solution where it is noticed that increasing the C factor (i.e. smaller tanks) will decrease the reduction factor  $\eta$ . This can be translated into concluding that smaller tanks are more likely to be affected by weather changes rather than larger ones. It is also



noticed that by increasing the outside heat-transfer coefficient  $\alpha_A$  (heavier rainstorm) the reduction factor will increase resulting in a higher thermal inbreathing rate.

### Case 3: Condensation

The vapor space is assumed to be saturated with water vapor at 55°C. Equation (35) can be rearranged to:

$$\dot{V} = \frac{V_G}{T_G} \left| \frac{dT_G}{dt} \right| \left( 1 + \frac{1}{Le^{0.66}} \frac{1}{p_G} \frac{dp^*}{dT} T_G \right) \quad (43)$$

Where:  $p^*$  = Vapor pressure (Pa)

The ratio of the maximum inbreathing of dry air due to condensable vapors in the tank to that of non-condensable vapors is defined as the “condensation factor  $\chi$ ” given by:

$$\chi = \frac{\dot{V}_{K,max}}{\dot{V}_{max}} = \left( 1 + \frac{1}{Le^{0.66}} \frac{1}{p_G} \frac{dp^*}{dT} T_0 \right) \left( \frac{\rho_{air} c_{air}}{\rho_G c_G} \right) \left( \frac{1 + \alpha_G/\alpha_A(C + 1)}{1 + \alpha_G/\alpha_A(C + K)} \right) \quad (44)$$

I
II
III

Each term in the above equation accounts for different contributions of condensation; Term I corresponds to the additional mass flux from the condensation of vapors inside the tank. Term II accounts for the differing heat capacity of the stored gas compared to that of the inbreathed air. Finally Term III refers to the lower temperature drops due to the release of the heat of condensation at the tank wall which results in lower maximum thermal inbreathing rates. Note that the term “K” in Equation (44) refers to a random constant defined by Fullarton as  $K = 1 + \alpha_{G,wet}/\alpha_G$  (refer to actual publication) [5].

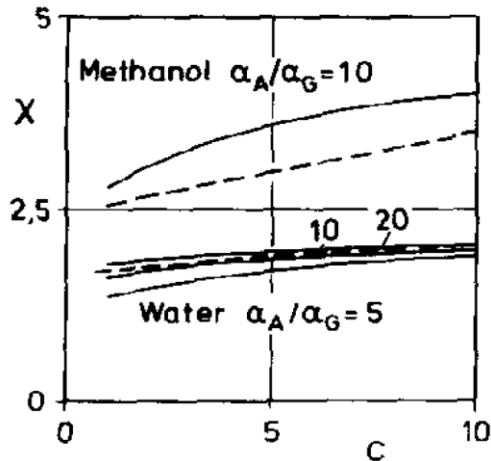

**Figure 12: Condensation Factor ( $\chi$ ) Vs. Capacity**

**Factor (C) for Different  $\alpha_A/\alpha_G$  [5].**

It can be seen that  $\chi$  is insensitive to both C-factor and rain intensity for a saturated water vapor. The latter is not true, however, for a vapor space saturated with methanol where increasing the C-value (smaller tanks) will increase the  $\chi$  value (higher inbreathing). The condensation factor  $\chi$ , therefore, relies on the type of condensable gas stored which allowed Fullarton to assign a range of  $\chi$  for different condensable gases as shown in Table 8.

**Table 8: Range of  $\chi$ -factor for Different Condensable Vapors [5]**

Vapor	$\chi$ -factor
Water vapor Heptane Hexane	1.5-2
Ethanol	2-2.5
Methanol	3-4

The resulting method for calculating the maximum inbreathing of a condensable vapor space is by using each of the Naumann approximation,  $\dot{V}_N$ , the reduction factor,  $\eta$ , and the condensation factor,  $\chi$ , as follows:

$$\dot{V}_{K,max} = \dot{V}_N \eta \chi \quad (45)$$

One must keep in mind that properties of air at 288K were used to derive this equation in addition to the assumption of the initial temperature gradient ( $T_{G,0} - T_A$ ) equal to 40°C. If other values are to be used, the above equation must be re-derived to account for the appropriate conditions.

### ***2.3.1.3. Results***

Fullarton performed both dynamic simulation as well as intermittent calculation using Equations (40), (41), (44), and (45) on a 4,000 m<sup>3</sup> empty tank intended for the storage of ethanol. The initial gas temperature was 55°C and was suddenly cooled by rain at 15°C. The rain fall was assumed to be an extremely heavy downpour (maximum event in 100 years) with  $\alpha_A/\alpha_G = 20$  and  $\alpha_G = 5 \text{ W/m}^2\text{K}$ .

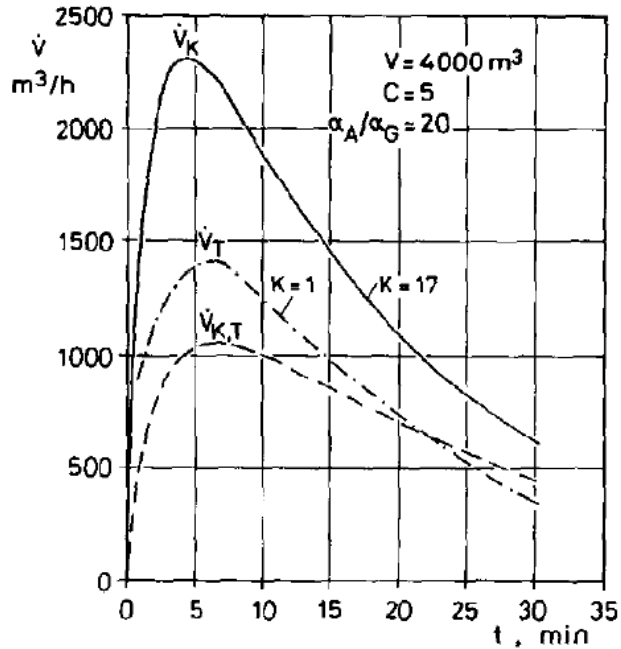

**Figure 13:  $\dot{V}_{max}$  vs Time for Condensable Water Vapor (K=17) [5].**

The simulation was performed and results were compared to a vapor space filled with dry air, i.e. empty tank, which is non-condensable. It can be seen that the maximum thermal inbreathing occurs at time  $t = 6$  min and that the inbreathing of the condensable vapor space ( $\dot{V}_{K=17}$ ) is 1.6 times larger than the dry air inbreathing ( $\dot{V}_{K=1}$ ). The fraction of inbreathing due to thermal contraction of water vapor is shown in the  $\dot{V}_{K,T}$  curve. The ratio  $\dot{V}_{K,T}/\dot{V}_K$  can roughly be estimated to a value of 0.5 implying that gas condensation and thermal contraction have equal contributions to the total thermal inbreathing requirement for water vapor.

To support his simulation on the inbreathing of condensable vapors, Fullarton et al. (1986) performed a bench scale experiment to study the effects of condensation on thermal inbreathing using a 6 L preheated gas flask under three different settings where the flask

was filled with: dry air, dry air saturated with water vapor, and dry air saturated with methanol. The flask was preheated to 55°C and then cooled by water jets at 15°C to simulate rain.

**Table 9: Maximum Inbreathing Results of Fullarton's Lab Scale Experiment**

Gas Mixture	$\dot{V}_{max}$ (L/h)	Dimensionless factors
Air	75-90	$\eta = 0.25$
Air/Water	150-180	$\chi = 2$
Air/Methanol	300-330	$\chi = 4$

Using Equation (40), the inbreathing flow rate according to Naumann's formula was calculated to be  $\dot{V}_N = 300$  L/h. The reduction factor was calculated for the case of dry air (no condensation) using Equation (41) whereas the condensation factor was calculated for the other two cases where condensation occurs using Equation (44). The maximum inbreathing rate was measured for each case and summarized in Table 9. It can be concluded that the more volatile the gas is, the higher its thermal inbreathing will be.

### 2.3.2. Model by PROTEGO© for Tanks Containing Condensable Vapors [8]

To be able to account for vapor condensation, Scholz and Weber [8] modified their model by adding Fullarton's condensable gas inbreathing rate equation [5]:

$$\frac{dV(T, t)}{dt} = \frac{V_{tank}}{T_{medium}(t)} \cdot \frac{T_{medium}(t)}{dt} \left[ 1 + \frac{1}{Le^{2/3}} \cdot \frac{1}{p_{total}} \cdot \frac{dp^*}{dT} \cdot T_{medium}(t) \right] \quad (46)$$

Where:  $Le$  = Dimensionless Lewis number defined as the ratio of  
thermal to mass diffusivity

$p_{total}$  = Total pressure of the system (bar)

$p^*$  = Vapor pressure at the operating temperature of the gas (bar)

Air was saturated with five different vapors: water, methanol, ethanol, heptane, and decane where the condensation effects of each vapor on thermal inbreathing were evaluated. The results of PROTEGO's simulation were compared to that of Fullarton's.

### 2.3.2.1. PROTEGO© Model of Fullarton's Tank

Fullarton's tank was defined as a flat-roof tank with both diameter and height equal to 17.21 m ( $H/D = 1$ ). The volume of the tank was equal to  $4,003 \text{ m}^3$  with a surface-to-volume ratio of 0.25. The free convective inside and outside heat-transfer coefficients had values of 5 and  $100 \text{ W/m}^2\text{K}$  respectively, as specified by Fullarton. The air was saturated with water vapor at  $55^\circ\text{C}$  and the tank was cooled by  $15^\circ\text{C}$  rain.

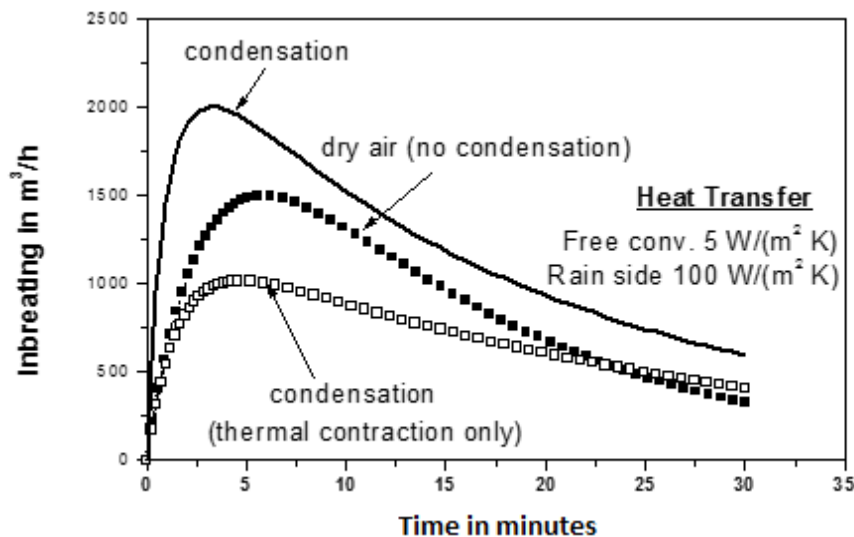

Figure 14: PROTEGO's Simulation of Fullarton's Water Vapor Inbreathing [8].

Figure 14 shows good agreement with Fullarton's results (Figure 13) which validated PROTEGO's model and allowed them to examine the impact of other types of condensable vapors on thermal inbreathing.

### 2.3.2.2. Condensable Vapor Model

Scholz and Weber [8] used a flat-roof tank with a 20 m diameter (H/D =1) and a 6,280 m<sup>3</sup> volume (S/V = 0.25) to study the effect of vapor condensation on inbreathing. The free convective inside and outside heat-transfer coefficients were fixed at 5 W/m<sup>2</sup>K and 50 W/m<sup>2</sup>K, respectively. The air was saturated with five different vapors: water, methanol, ethanol, heptane, and decane.

**Table 10: Vapor Pressure as a Function of Temperature for Different Gases**

Vapor	Vapor pressure (bars) = f (T in Kelvins)	Le	$\Delta H_{\text{cond}}$ (kJ/kg)
Methanol	$p^* = 10^{-5} \times e^{81.768 - \frac{6876}{T} - 8.7078 \ln(T) + 7.1926 \times 10^{-6} T^2}$	0.7	1128
Ethanol	$\ln(p^*) = 12.29 - \frac{3804}{T - 41.65}$	1.16	892
Heptane	$p^* = e^{-17,49562 + (0.04911) T}$	1.46	355
Water	$p^* = 0.00611 \times e^{-5304.3 \left( \frac{1}{T} - \frac{1}{273.16} \right)}$	0.869	2365.3
Decane	$p^* = 10^{-5} \times e^{112.73 - \frac{9749.6}{T} - 13.245 \ln(T) + 7.1266 \times 10^{-6} T^2}$	2.9	347

In order to calculate the inbreathing requirement, the dependence of the vapor pressure on temperature for each gas must be determined using Antoine's equation or any

other experimental means. Table 10 above summarizes the vapor pressure dependence for each type of gas and are sorted from highest to lowest volatility.

For any given change in temperature, the pressure drop due to contraction/condensation is estimated, using the relations in Table 10, and the set point pressure for the venting device is thus obtained from the latter. Therefore, one can conclude that the vapor pressure dependence on temperature is the mass transfer driving force for thermal inbreathing of condensable vapors.

Using Equation (46) and Table 10, the inbreathing rate for each gas type was simulated in PROTEGO's software and was plotted against time as shown in Figure 15. It can be seen that the condensation of volatile vapors have a significant impact on the inbreathing rate causing the latter to have a twofold increase. On the other hand, condensation of non-volatiles, decane in this case, does not affect the inbreathing rate and yields the same inbreathing profile as with dry air.

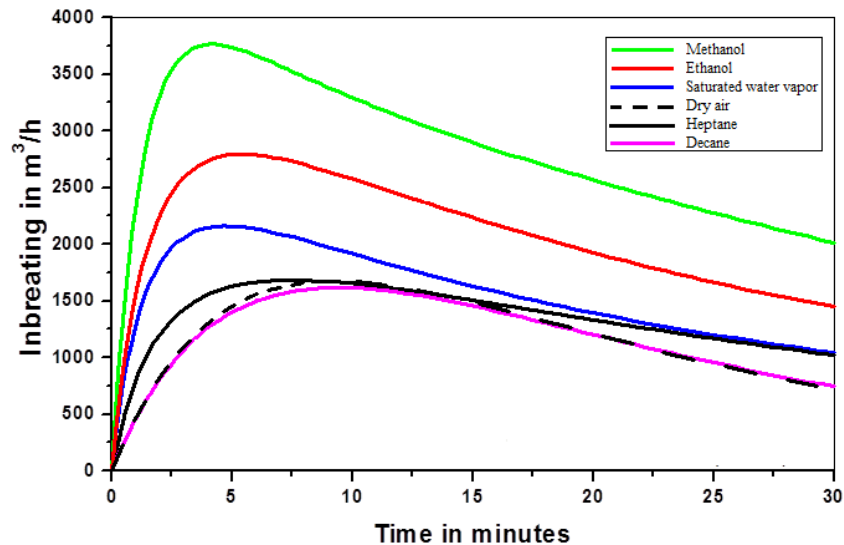

**Figure 15: Impact of Vapor-Space Condensation on Inbreathing [8].**



PROTEGO© [8] obtained the maximum inbreathing rates for the different vapors and compared their condensation factor,  $\chi$ , ratios to that of Fullarton's (Table 9) in the table below.

**Table 11: Ratio of the Maximum Inbreathing With Condensation to Without Condensation.**

<b>Vapor</b>	$\dot{V}_{K,max}$ <b>With condensation (m<sup>3</sup>/h)</b>	$\dot{V}_{max}$ <b>Without condensation (m<sup>3</sup>/h)</b>	$\chi_{PROTEGO}$ <b>[8]</b>	$\chi_{Fullarton}$ <b>[5]</b>
Methanol	3,765	790	4.76	3-4
Ethanol	2,793	1,254	2.23	2-2.5
Heptane	1,687	1,050	1.61	1.5-2
Water	2,160	1,673	1.29	1.5-2
Decane	1,615	1,600	1.01	N/A

The calculated ratios of the PROTEGO© model are all in agreement with the published values [5] except the  $\chi$  ratio of methanol which is greater than the range specified by Fullarton (1986). However, a possible explanation for this is that PROTEGO© used additional conservativeness (higher safety margin) when dealing with extremely volatile vapors like methanol.

## **2.4. Large Scale Data**

Large scale experimental data is needed to give researchers insight about the actual phenomena occurring in the storage tank, which will be used in turn to assess the validity of theoretical methodologies and simulations.

The following section reviews two sets of large scale data from actual experiments on low-pressure storage tanks. The first is for non-condensable gases by *Sigel et al.* [6] and the second is for condensable gases by *Holtkoetter et al.* [7].

### **2.4.1. Sigel et al. Experimental Data [6]**

Sigel performed actual data collection for the thermal inbreathing rate from a large tank of 617.5 m<sup>3</sup> capacity exposed to high solar radiation. The artificial rain was created by using water sprays falling on the tank roof which allowed for the control of both the water flow and temperature. The tank had an 8.5 m diameter and a 10.6 m height; thus the aspect ratio  $f$  was equal to 1.25. The tank was empty without any trace of product vapor or liquid residue.

Sigel et al. [6] developed their own thermal inbreathing model, found in Appendix A, to compare their experimental results to. Figure 16 below displays the measured values of inbreathing vs. those calculated using the Hoescht equation (as cited by Sigel [6]). The measurements were repeated 11 times to ensure the reproducibility of the experiment and the reliability of the data. It can be noticed that the calculated flow rates are always (13-56%) higher than the actual readings due to the fact that a safety factor is always accounted for in theoretical equations.

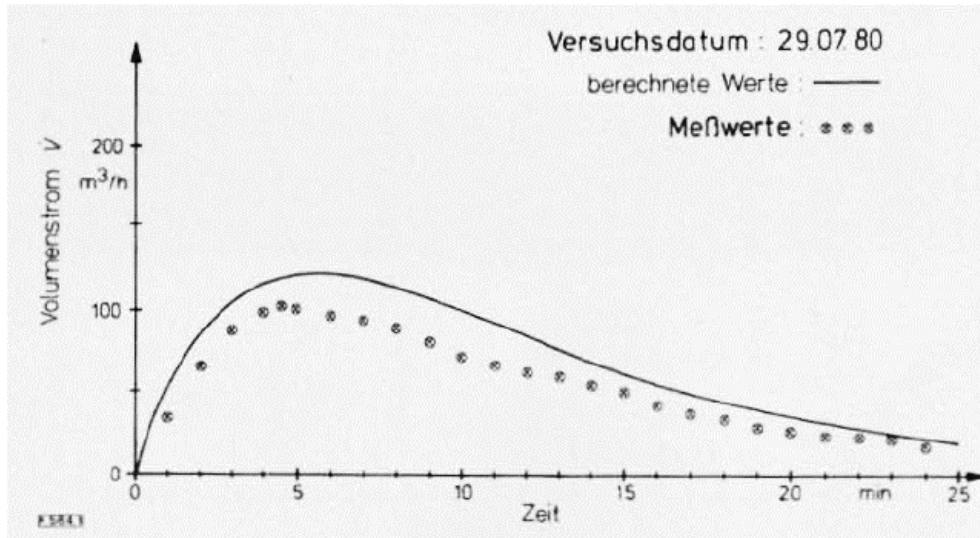

**Figure 16: Measured Vs. Calculated Values of Inbreathing Rates [6].**

Fullarton used his method to compare to Sigel's experimental work by using a capacity factor  $C = 10$ , a heat-transfer coefficient ratio  $\alpha_A/\alpha_G = 15$ , and a reduction factor  $\eta = 0.45$ . Fullarton reported that his method resulted in values of maximum inbreathing 20% to 30% higher than the measured flowrates [6].

#### 2.4.2. Holtkoetter et al. Experimental Data [7]

Holtkoetter's main contribution was distinguishing spontaneous condensation that forms aerosol from the condensation taking place at the tank wall. Holtkoetter performed an experiment on a 1.18 m<sup>3</sup> tank to measure the actual inbreathing rates to which his theoretical model was then compared to. This experimental investigation aimed at studying the effects of condensation on thermal inbreathing for three different vapors: water, isopropanol, and methanol.

### 2.4.2.1. Experimental Setup

The cylindrical atmospheric-tank used in the experiment had a height of 1.5 m and a diameter of 1 m with a wall thickness equal to 1.2 mm. The initial temperature of the gas and the wall were 55°C and 31°C respectively. The tank was cooled by water sprays (15°C) to simulate rain with a mass flow rate of 10 kg/h covering 5.5 m<sup>2</sup> of the tank's outer-shell area (wetted area).

Abbildung 1.  
Schema der Versuchsanlage.

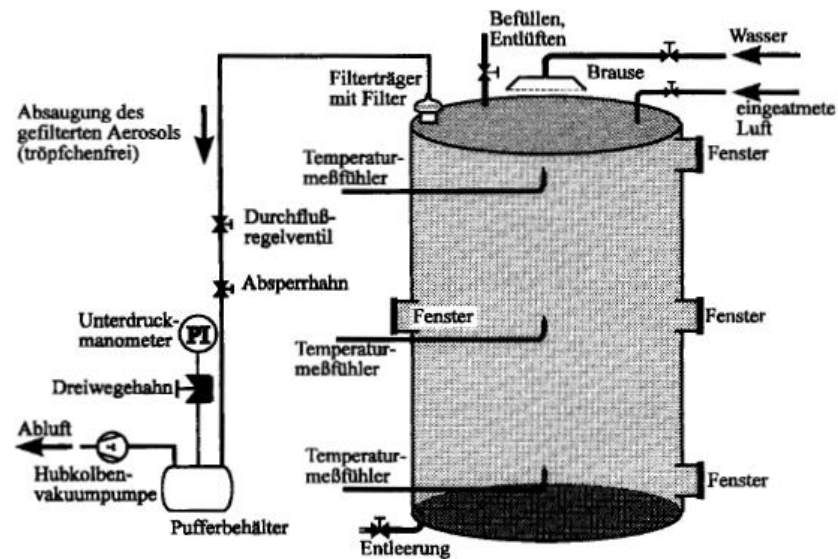
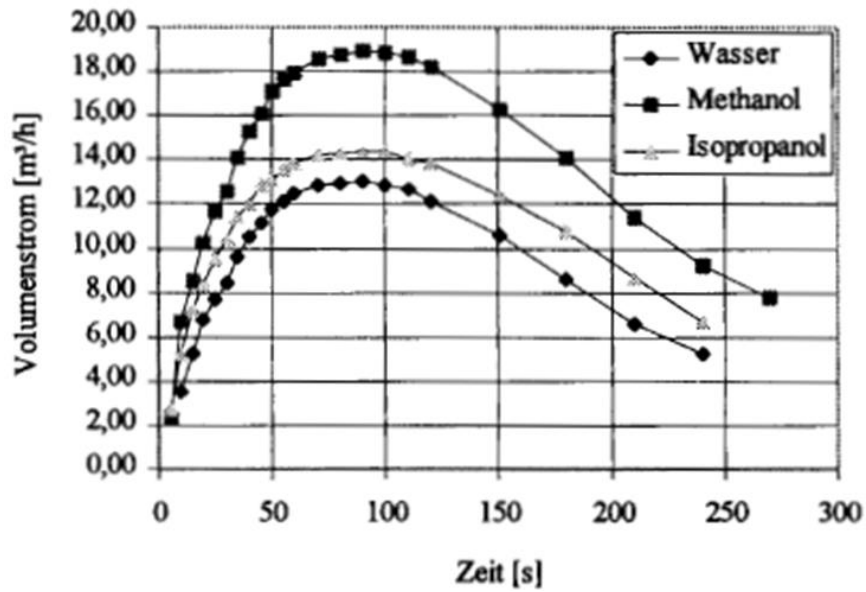

Figure 17: Holtkoetter Experimental Tank [7]

The three windows (Fenster) in Figure 17 allow for visual inspection of the entire tank atmosphere. The filter found at the tank roof is used for measuring the fraction of condensate formed by spontaneous condensation. More details of the setup can be found in the actual publication [7].

### 2.4.2.2. Results

The inbreathing rates were measured when the gas-rain temperature difference was achieved at a value of 40°C. The latter value was set by API 2000 [2], where the initial gas temperature of 55°C and the rain temperature of 15°C, as the maximum temperature difference for thermal inbreathing calculations and was used in numerous models [4, 5, 6].



**Figure 18: Thermal Inbreathing Profile for Water, Isopropanol, and Methanol [7].**

The maximum thermal inbreathing is recorded after almost 95 seconds for all three gases.  $\dot{V}_{max} \approx 19 \text{ m}^3/\text{h}$  of methanol is significantly higher than both water ( $\dot{V}_{max} \approx 13 \text{ m}^3/\text{h}$ ) and isopropanol ( $\dot{V}_{max} \approx 14 \text{ m}^3/\text{h}$ ) owing to the fact that methanol is the most volatile vapor.

## 2.5. Rain Correlation and Storm Classification

Although API 2000 specifies a value of 225 kg/m<sup>2</sup>h for the rain intensity that corresponds to a rain/wall heat transfer coefficient equal to 5,000 W/m<sup>2</sup>K, there hasn't been an agreement on these values in the literature.

The table above summarizes the values for different types of rainstorms used in each model.

**Table 12: Types of Rainstorms**

Rainstorm Type	Fullarton [5]	PROTEGO© [8]		LR [11]
	H <sub>rain</sub> (W/m <sup>2</sup> K)	H <sub>rain</sub> (W/m <sup>2</sup> K)	M <sub>rain</sub> (kg/m <sup>2</sup> h)	H <sub>rain</sub> (W/m <sup>2</sup> K)
Average	25	37	75	-
Heavy	50	50	150	50
1 in 100 years Downpour	100	500	225	356

### 2.5.1. Lloyd's Register Rain Correlation

Brooks [11] used the Lloyd's Register (LR) model [11] to examine the effect of different rain intensities (mm/h) on the outside heat transfer coefficient. As one might expect, the more it rains, the more enhanced the heat transfer between the wall and rain becomes. This is reflected by an increase in the value for the rain/wall heat transfer coefficient. Figure 19 shows the linear dependence of the rain/wall heat transfer coefficient on rain intensity that Lloyd's Register verified.

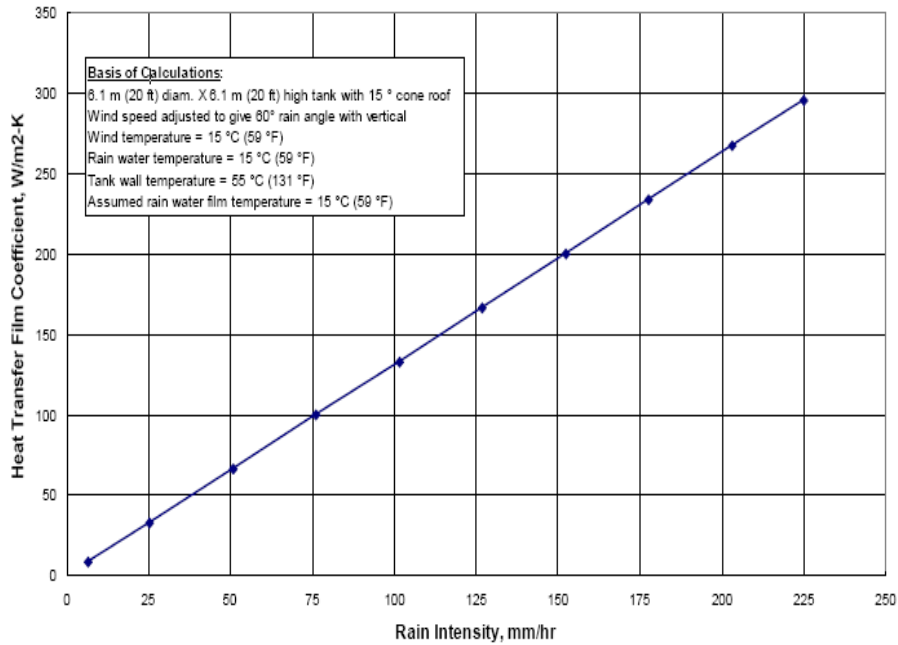

**Figure 19: Rain/Wall Heat-Transfer Coefficient  
as a Function of Rain Intensity.**

The method Brooks [11] used to obtain the wind-driven-rain loading on the tank shell was by John Straube (as cited by Brooks, 2012). A tank of diameter  $D = 6.1$  m, a height-to-diameter ratio  $H/D = 1$ , and a volume of  $184.18 \text{ m}^3$  was used. The estimation of the heat transfer coefficient was done by Granyard's method (as cited by Brooks, 2012). Fitting the above data on a linear plot of linear regression fit  $R^2 = 1$ , Equation (47) is then obtained:

$$h_o = 1.31 \dot{m}_R - 0.29 \quad (47)$$

Where:  $h_o$  = Tank-wall rain film heat transfer  
coefficient ( $\text{W}/\text{m}^2\text{K}$ )

$\dot{m}_R$  = Rain intensity (mm/h)

It should be noted that this is not a generalized equation as it has not been tested nor verified for different tank volumes. However, Equation (47) was implemented in the SuperChems-based model for this study.

### 2.5.2. Effective Rain Intensity

Rain fall can occur at different angles due to wind direction and speed. For example, a tank exposed to vertical rainfall (90° angle with horizontal) will experience different heat transfer than a tank exposed to rain at a 30° angle with the horizontal. The former will experience higher cooling rates through the roof whereas the latter will have the higher cooling rates through its shell (side walls).

To account for impact of the rain angle, an effective rain intensity known as the Hoechst-Gleichung effective rain intensity cited and used by many researchers [4, 5, 6, 8]. The effective rain intensity is calculated as follows:

$$\dot{m}_{eff} = \frac{\dot{m}_w}{S} \left( \frac{\pi D^2}{4} + DH \cot \omega_R \right) \quad (48)$$

Where:  $\dot{m}_{eff}$  = Water film intensity (kg/m<sup>2</sup>h)

$\dot{m}_w$  = Rain intensity (kg/m<sup>2</sup>h)

$\omega_R$  = Rain angle with the horizontal (°)

$D$  = Tank diameter (m)

$H$  = Tank height (m)

$S$  = Tank rain-wetted surface area (m<sup>2</sup>)



### 3.0 SUPERCHEMS-BASED MODEL SIMULATIONS

The case studies evaluated in this work used SuperChems Expert™, a component of ioMosaic's Process Safety Office™ [10]. Dynamic models within SuperChems Expert™ calculate vessel characteristics over time based on real time specified process conditions. The steady-state models produce results one point at a time, based on stationary inputs. Dynamic models continually generate results that are used as the initial conditions for the next time interval calculation which perpetually drives the model to completion.

Two dynamic models, two-phase and vapor, allow users to customize and simulate the workings of any given chemical process and set up a simulation in any number of ways.

#### 3.1. Vessels Containing Two Phases (Dynamic)

The two-phase vessel model enables advanced simulation of vessels containing a material capable of relieving two-phases, liquid, and vapor. This model solves various differential equations that describe the mass and energy balances for a vessel. The user defines the system and specifies the initial conditions. SuperChems Expert™ solves the differential equations for scenarios such as runaway reactions and/or fire exposure, tube failure, etc. Temperature, pressure, composition and flow are calculated as a function of time for the defined vessel and piping layout geometry. This model fully supports the Design Institute for Emergency Relief Systems (DIERS) technologies including the "DIERS Coupling Equation" as evident when appropriate flow types (churn-turbulent or bubbly flow) and disengagement parameters are specified [10]. This model was used to

simulate the thermal inbreathing of tanks saturated with condensable gases such as Fullarton [5] and Holtkoetter [7].

### **3.2. Vessels Containing Vapor (Dynamic)**

This model enables advanced dynamic simulation of vessels containing gases and/or vapor. This include supercritical flow, where fluid temperature is at or higher than its critical point. This model was used to calculate the inbreathing of storage tanks filled with dry air such as Sigel's tank [6].

### **3.3. Wall Dynamics**

The vessel dynamics models in SuperChems Expert™ include wall-fluid heat transfer dynamics. Vessel wall dynamics models also include incoming and outgoing fluid streams, to connect a particular vessel to other vessels, and to connect relief and process lines to the top and the bottom of the vessel.

To account for detailed vessel wall and fluid heat transfer dynamics, the simulated equipment in this thesis is segmented into multiple zones, as shown in Figure 20.

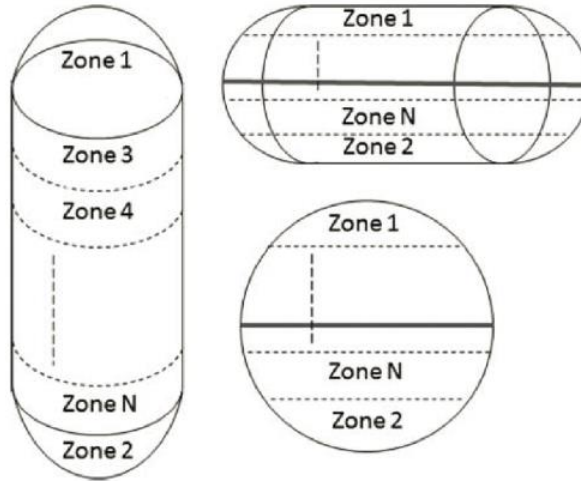

Figure 20: SuperChems Expert™ Segmentation Scheme [10]

Detailed heat transfer to/from the surroundings and between the zones is dynamically accounted for. The ability to divide an equipment into multiple segments allows to closely examine the dynamics of the fluids and vessel wall thermal effects. Other valuable applications of the segmentation approach include the modeling of external fire, rainstorms, localized heating, and flame jet impingement.

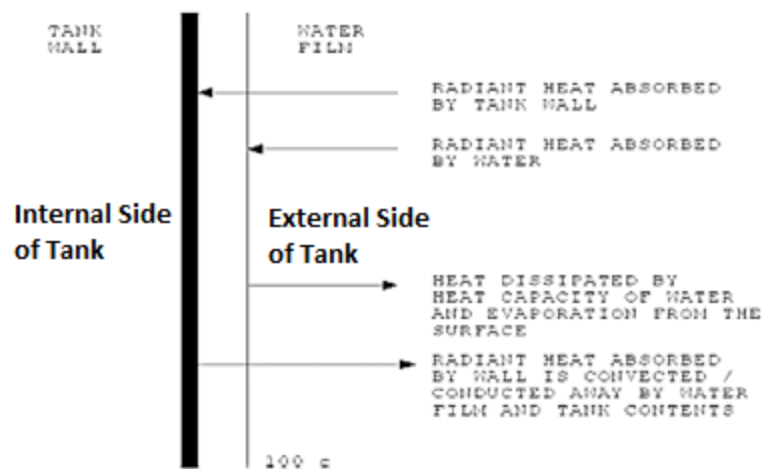

Figure 21: Heat Transfer Mechanisms for a Tank during a Rainstorm [10]

Once segmentation is defined, heat transfer analysis is applied per wall segment: (1) ambient to wall segment heat transfer options include insulation, solar heating, rain, water sprays, and pool fire; (2) the wall segment to fluid heat transfer includes radiation, natural convection, forced convection, film boiling, and pool boiling.

## 4.0 RESULTS AND DISCUSSION

The SuperChems-based model, discussed in the previous section, was used to replicate the large scale data thus providing comparison to previous work discussed in Chapter 2. Large scale data provided by Sigel [6] and Holtkoetter [7] was simulated in SuperChems Expert™, in addition, the simulations provided by PROTEGO© were also reproduced using SuperChems Expert™ to ensure that this proposed model can adequately predict the inbreathing rates for liquid storage tanks.

### 4.1. SuperChems Simulation of Sigel's Results [6]

The dimensions of the 617.5 m<sup>3</sup> empty tank used by Sigel (1983) were introduced as input parameters to SuperChems. The original experiment took place on 29 July 1980 and skies were clear with 0% cloud coverage, 2 m/s wind speed and 15°C ambient temperature. The location of the tank was inputted in SuperChems by using the longitude 13.4167° E and a latitude of 52.5333° N of Berlin, Germany.

The tank was divided to 5 segments all exposed to solar heating. The tank contained 79 mol% Nitrogen and 21 mol% Oxygen to resemble dry air. Air was inbreathed through a 10" ideal nozzle whose backpressure curve was calculated in order to determine the mass flow across this nozzle as a function of pressure drop inside the tank. The maximum pressure drop recorded for this tank was -0.01 psig.

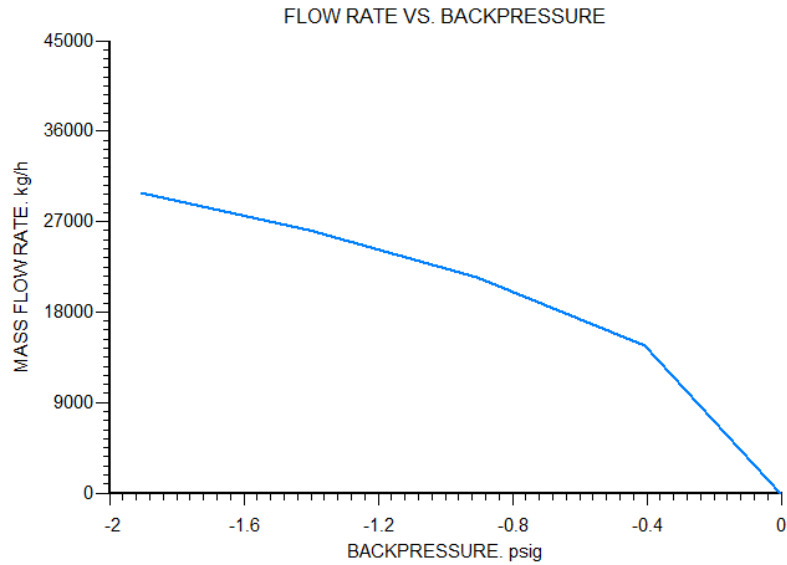

**Figure 22: Backpressure Flow Response Curve for a 10" Ideal Nozzle for Air**

The rainstorm used in this simulation had an intensity of 0.38 inch/h and a duration of 30 minutes. The rain temperature was set 15°C. The corresponding heat transfer coefficient between the rain and the outer-shell was calculated to 16.26 W/m<sup>2</sup>K by using Lloyd's Register correlation [11]. The inside heat transfer coefficient value specified by API 2000 [2] was used and is equal to 5 W/m<sup>2</sup>K.

The model prediction, shown in Figure 23, is considered reasonable taking into account the fact that some parameter values, such as the convective heat transfer coefficient and the size and number of relief valves used, were not reported by Sigel et al. [6].

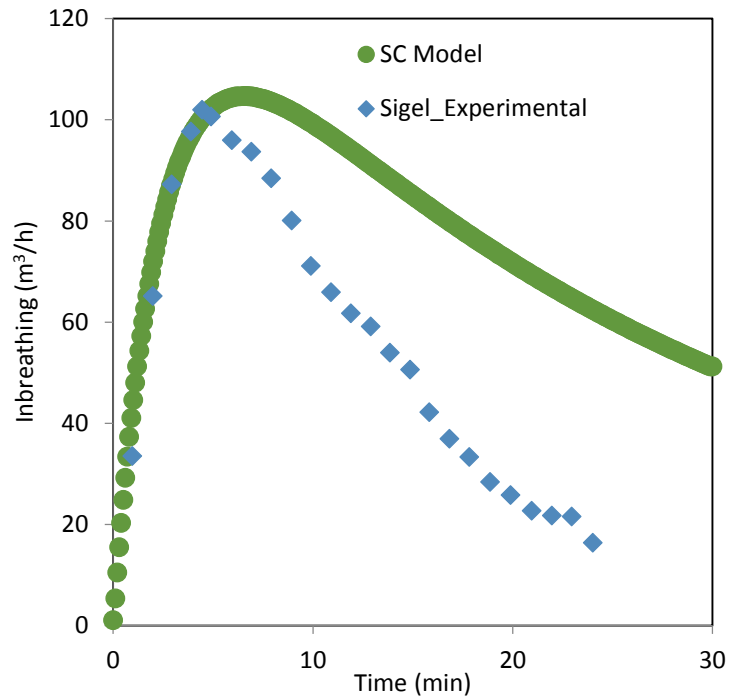

**Figure 23: Simulation of Sigel's Tank using SuperChems**

The maximum value for inbreathing predicted by SuperChems was  $104 \text{ m}^3/\text{h}$  at time  $t = 6.6 \text{ min}$ . This value is at a 2% deviation from the actual recorded maximum. The model's slope matches the first part of the inbreathing curve up until the maximum. Although the slopes of the decay of the inbreathing are different, they do not contribute to the design of the relief valve because the most important value extracted from such studies is the maximum inbreathing that will act as the design relief capacity of the venting device.

The figures below show the temperature profiles of the wall segments and air inside the tank in addition to the temperature rise rate from the SuperChems simulation. Since Sigel [6] did not disclose the actual temperature profiles, we could not compare the latter data to actual readings.

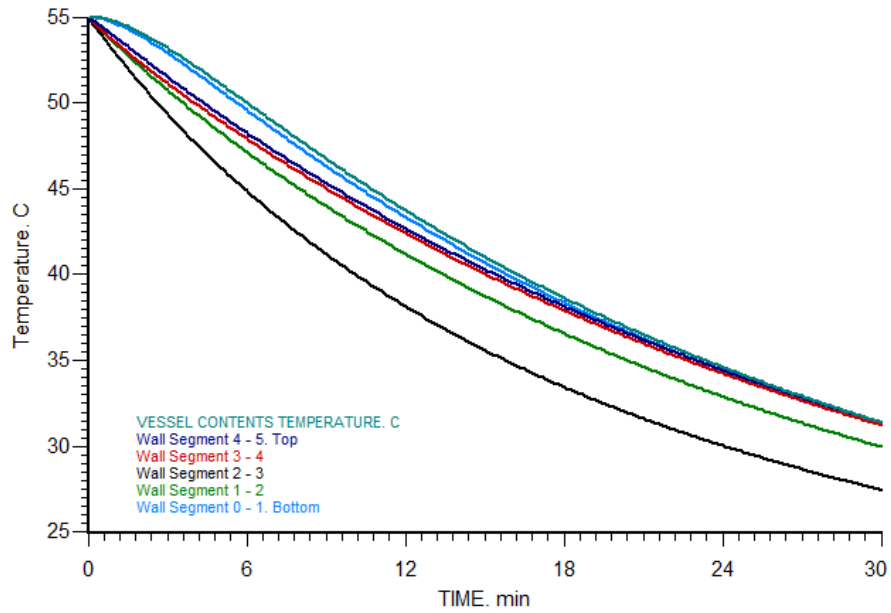

**Figure 24: Temperature Profile of Sigel's Tank (SuperChems)**

By the time the rainstorm stops, at  $t = 30$  mins, the temperature of the air inside the tank has cooled from  $55^{\circ}\text{C}$  to almost  $30^{\circ}\text{C}$ . Therefore, the average temperature drop rate of the vessel contents is around  $-0.83^{\circ}\text{C/h}$ . The actual instantaneous temperature drop rate is shown in the figure below.

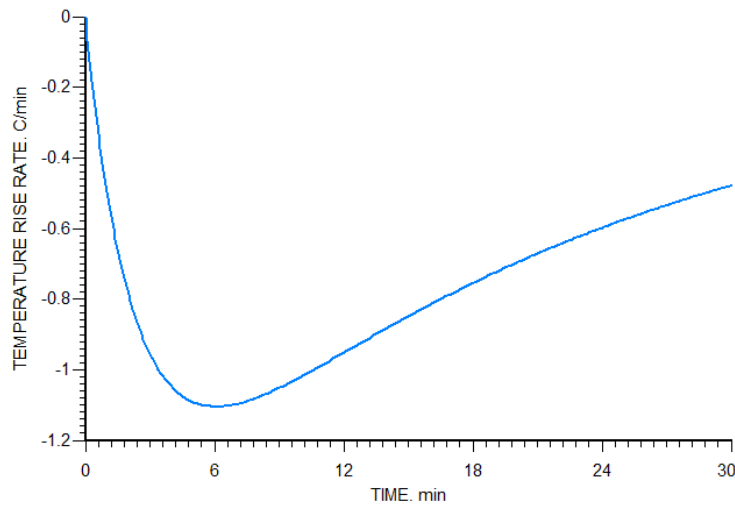

**Figure 25: Temperature Change Rate for a Simulation of Sigel's Experimental Results [6] (SuperChems)**



Here it can be seen that at  $t = 6.6$  min, the maximum temperature change rate is to  $-1.1$  °C/h. This agrees with the dependence of inbreathing on the rate of temperature change found in literature [2].

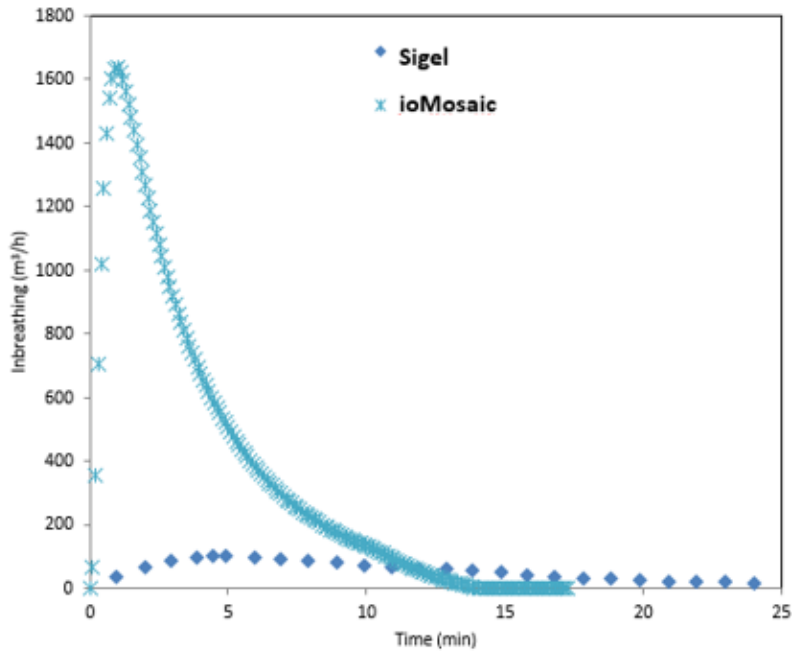

**Figure 26: Inbreathing Profile Using Sigel's "Assumed" Parameters (SuperChems).**

*Sigel et al.* [6] did not measure or compute the heat transfer coefficients for natural convection inside the tank, instead, they assumed values for the heat transfer coefficients similar to API 2000. The  $h_{\text{gas}}$  and  $h_{\text{rain}}$  were assumed to be  $5.56$  W/m<sup>2</sup>K and  $5,555.6$  W/m<sup>2</sup>K, respectively. These values were inputted to SuperChems and the obtained results are shown in Figure 26 above. It can be seen that the latter values for the heat transfer coefficients are too conservative as they overestimate the actual inbreathing by almost 16 fold.

## **4.2. SuperChems Simulation of Holtkoetter's Tank**

*Holtkoetter et al.* [7] performed an experiment to measure the inbreathing of a 1.18 m<sup>3</sup> tank with a 1.5 meter height and a 1 m diameter. The wall thickness of Holtkoetter's tank was 1.2 mm. The three vapors studied were: methanol, isopropanol and water. For each type of vapor, the tank was filled with a small amount of liquid (such as liquid methanol) and then vaporized by heating the tank using three infrared radiators (2.5-4.2 kW). The measured inbreathing profiles can be found in Figure 18 (Section 2.4.2.).

The tank was divided to 5 segments and the tank was not exposed to solar heating since the experiment was done indoors. The initial gas and wall temperature were 55°C and 31°C respectively. The rain temperature was kept constant at 15°C and the ambient temperature was 10 °C. Air was inbreathed through a 10" ideal nozzle, the maximum pressure drop formed inside the tank was -0.01 psig.

The rain/wall heat transfer coefficient,  $h_{rain}$ , was fixed at 600W/m<sup>2</sup>K for all vapors. The latter value corresponds to the rain intensity specified by Holtkoetter which is equal to 0.1262 kg/m<sup>2</sup>s with a wetted outer-area of 5.5 m<sup>2</sup>. The duration of the rain for this simulation was 300 seconds. The  $h_{gas}$  was initially set to 5 W/m<sup>2</sup>K since this is the value but was then adjusted in order to reproduce the actual inbreathing profiles. The following section will cover the inbreathing and temperature profiles isopropanol obtained using the "Two-Phase Dynamic Model" in SuperChems. The results for both water vapor and methanol can be found in Appendix B of this document.

#### 4.2.1. Simulation Results of Tank Saturated with Isopropanol

A mixture of 58 mol% Isopropanol and 42 mol% Nitrogen was used to achieve a saturated mixture at 55°C and 0 psig. Figure 27 illustrates the inbreathing profile for two different values of the free-convection heat transfer coefficient of the gas,  $h_{\text{gas}}$ , inside the tank. The red curve of Figure 27 is obtained using  $h_{\text{gas}} = 5 \text{ W/m}^2\text{K}$  where it can be seen that  $\dot{V}_{\text{max}}$  is under-predicted by -62.2 %.

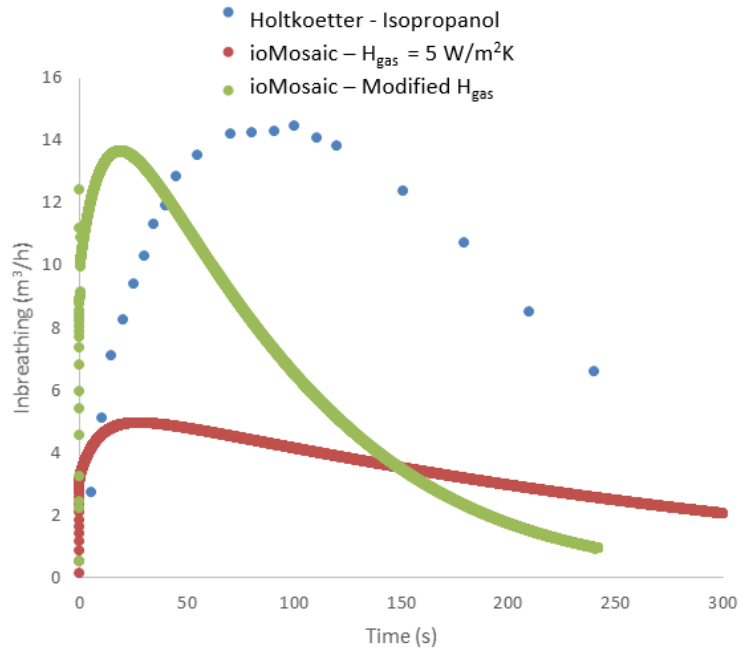

**Figure 27: Isopropanol Vapor Inbreathing Profile (SuperChems)**

In order to match the simulation results with the experimental ones, a higher value for  $h_{\text{gas}}$  equal to 30  $\text{W/m}^2\text{K}$  was used. The latter value resulted in the green inbreathing curve in Figure 27 that matched the experimental value for maximum inbreathing and had a deviation of -1.7% which lies within the  $\pm 5\%$  error margin. The inbreathing profiles obtained from the SuperChems-model are much faster than the experimental profile where the time to achieve maximum inbreathing was at  $t = 13.64$  seconds. It should be noted,

however, that the only important value extracted from this model is the maximum inbreathing which will be the basis of designing the adequate relief device.

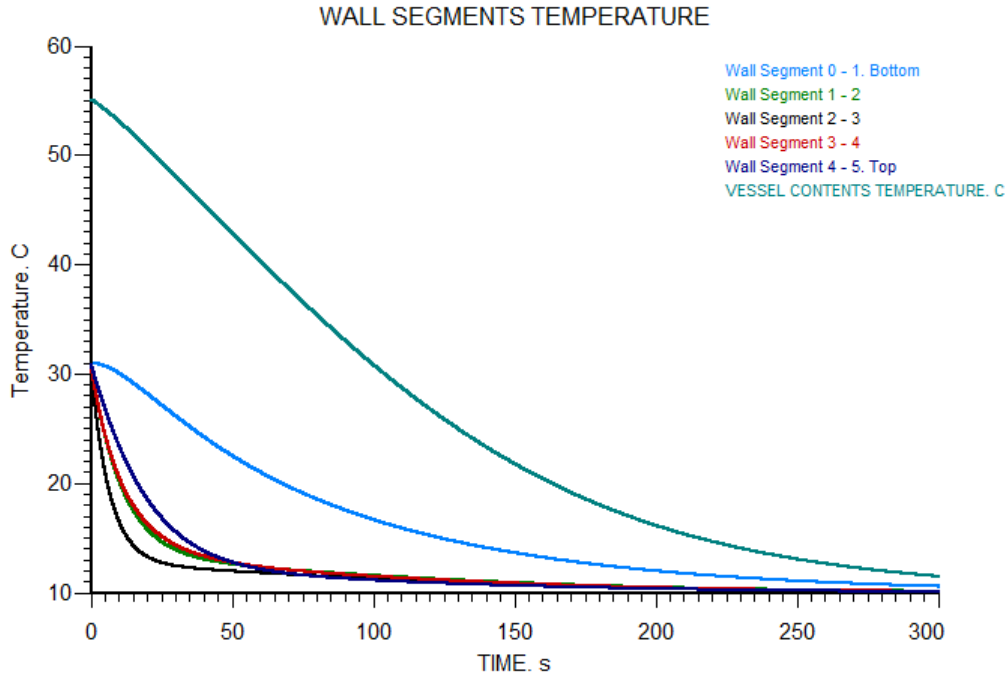
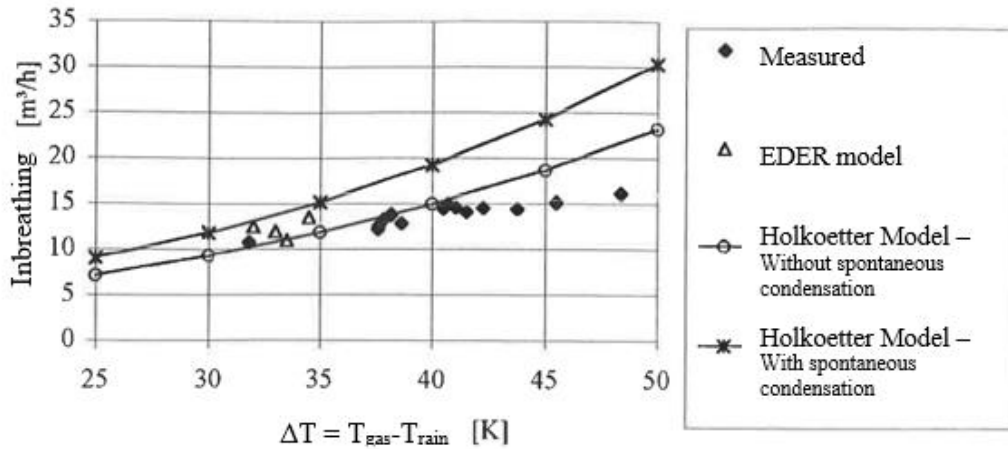

**Figure 28: Isopropanol Vapor Temperature Profile (SuperChems)**

The temperature profile obtained from the SuperChems-model can be seen in Figure 28 where the temperature profile of the vessel contents in addition to the 5 wall segments is shown. The temperature of the top wall segment (i.e. roof) experiences the fastest cooling since it is in direct contact with the rain, whereas the temperature of the tank bottom exhibits the slowest temperature decay. All the segment temperatures cool down to the ambient temperature (10°C). This is due to the fact that the tank bottom is not exposed to rain since the tank foundations are built deep in the ground.

#### 4.2.2. SuperChems Results Vs. Holtkoetter's Model Results

Although *Holtkoetter et al.* [7] performed experimental work to measure the maximum inbreathing, they did not, however, compare their experimental results to their proposed model. Instead, Holtkoetter [7] verified his model by plotting the inbreathing,  $\dot{V}_{IT}$ , versus  $\Delta T = T_{\text{gas}} - T_{\text{rain}}$  (Figure 29). *Holtkoetter et al.* justified their graphing choice by stating that the experiment was done in the month of December where the available water had a temperature of 8°C instead of 15°C. Colder rain will eventually lead to higher inbreathing values, therefore, the inbreathing should be inspected as a function of temperature to account for this 7°C difference in the water temperature.



**Figure 29: Inbreathing Versus Temperature Difference – Isopropanol [7]**

Holtkoetter did include, however, in “Anhang D” of his report, the inbreathing values calculated at each time step using his model. These values were extracted and plotted to generate an inbreathing versus time profile which was then compared to the SuperChems-model inbreathing profile shown in Figure 30 below.

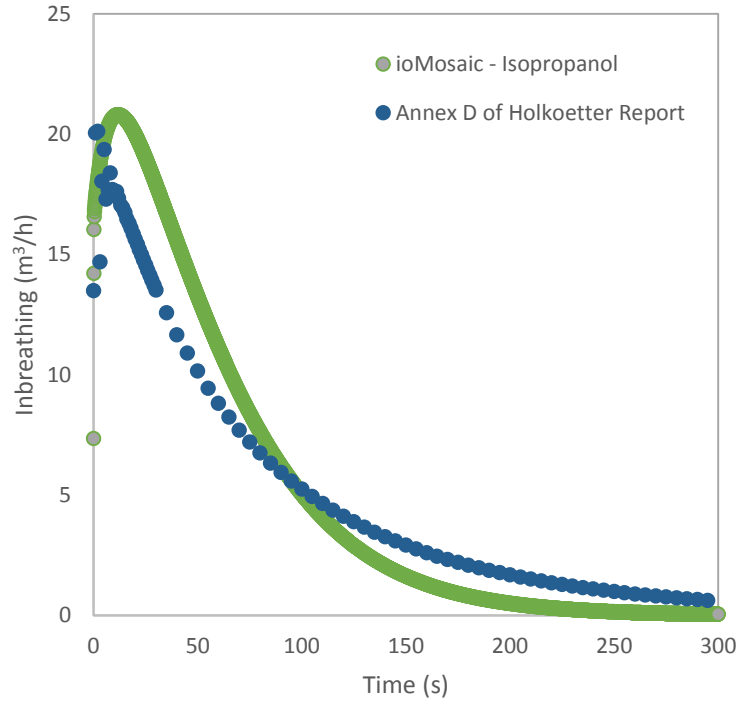

**Figure 30: Inbreathing Profile of Isopropanol - SuperChems versus Holtkoetter Model.**

It can be seen that the SuperChems-based model shows good agreement with the Holtkoetter model that considers spontaneous condensation. The predicted value for the  $\dot{V}_{max}$  using SuperChems was 20.7 m<sup>3</sup>/h and is at a +3% error from the value reported by Holtkoetter [7]. The gas and wall temperatures were also reported in “Anhang D” of Holtkoetter’s report and are shown in Figure 31. It should be reemphasized that the rain temperature used for this simulation is 8°C.

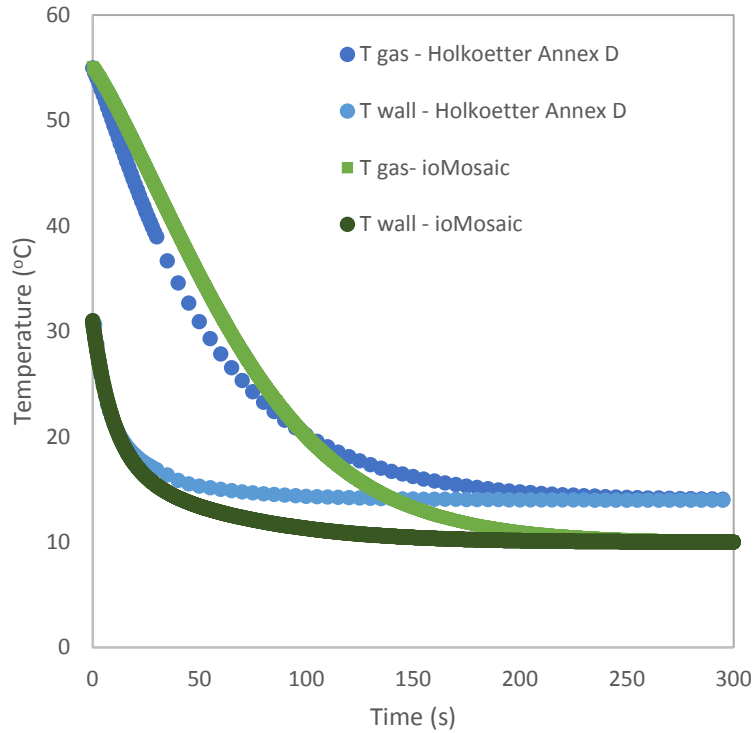

**Figure 31: Temperature Profile Isopropanol - SuperChems versus Holtkoetter model.**

The calculated temperatures using SuperChems Expert™ match those calculated by Holtkoetter's spontaneous condensation model. These results indicate that the modification of the convective heat transfer coefficients,  $h_{\text{gas}}$  ( $30 \text{ W/m}^2\text{K}$ ) and  $h_{\text{rain}}$  ( $600 \text{ W/m}^2\text{K}$ ), are adequate given the fact that both the inbreathing and temperature profiles were accurately reproduced using SuperChems Expert™.

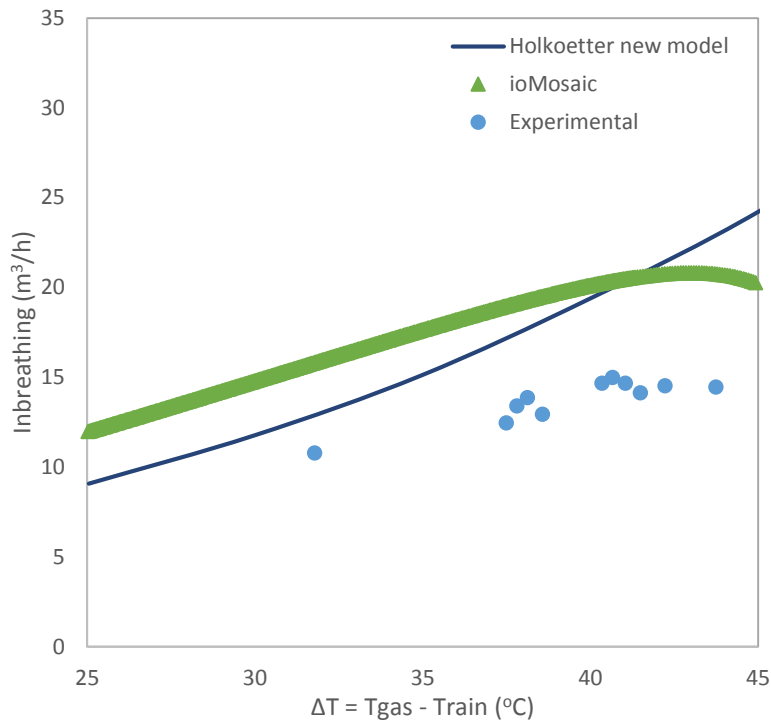

**Figure 32:  $V_{\max}$  as a function of  $\Delta T$  for Isopropanol - SuperChems vs. Experimental.**

Using the SuperChems model, the predicted inbreathing flow rates were plotted against the temperature gradient,  $\Delta T = (T_{\text{gas}} - T_{\text{rain}})$ , in Figure 32. Note that both models, SuperChems and Holtkoetter, are conservative since the model predictions of inbreathing values are higher than the actual inbreathing rates recorded during the experiment. Therefore, both models are proved to be valid when it comes to the prediction of the relief requirements of a storage tanks with condensable vapors.

#### **4.3. SuperChems Simulation of PROTEGO© Models**

PROTEGO© modeled the inbreathing of non-condensable dry air (Section 2.2.3) in addition to five different types of condensable vapors: methanol, ethanol, heptane, water,



and decane (Section 2.3.2). These models were replicated in SuperChems Expert™ using the vapor-phase dynamic model (for dry air) and two-phase dynamic model (for condensable vapors) where a very small initial liquid level equal to 0.1% was used.

The heat transfer coefficient on the rain side was fixed at  $37\text{W/m}^2\text{K}$  (for dry air) and  $50\text{W/m}^2\text{K}$  (for condensable vapors) whereas the heat transfer coefficient of the gas/wall,  $h_{\text{gas}}$ , was varied until the inbreathing profile was successfully reproduced.

#### **4.3.1. PRETOGO© Assumptions for Condensable Vapors**

There are three major assumptions made by PROTEGO© to achieve their condensable-vapor models for inbreathing. The first assumption was neglecting the wall heat capacity i.e. the wall thickness in their model was close to null. The latter assumption was made to increase the conservativeness of the thermal inbreathing predictions. It was found that using a 1 mm wall thickness in SuperChems Expert™ satisfies this assumption.

The second assumption was using a vapor-only model to obtain the thermal inbreathing for condensable vapors. Pure vapors, water for example, were present in the tank at  $55^\circ\text{C}$  and 0 psig. The heat of condensation released at the inner walls of the tank was manually added to the energy balance by PROTEGO©.

The third assumption was using a single-volume lumped capacitance approach where both the gas and wall temperatures are homogeneous. This approximation is handled in SuperChems Expert™ by segmenting the vessel into multiple zone to account for the heat conduction across the wall and between the zones (Figure 33).

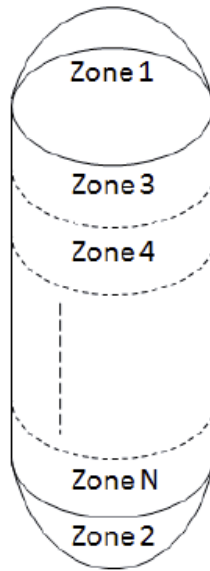
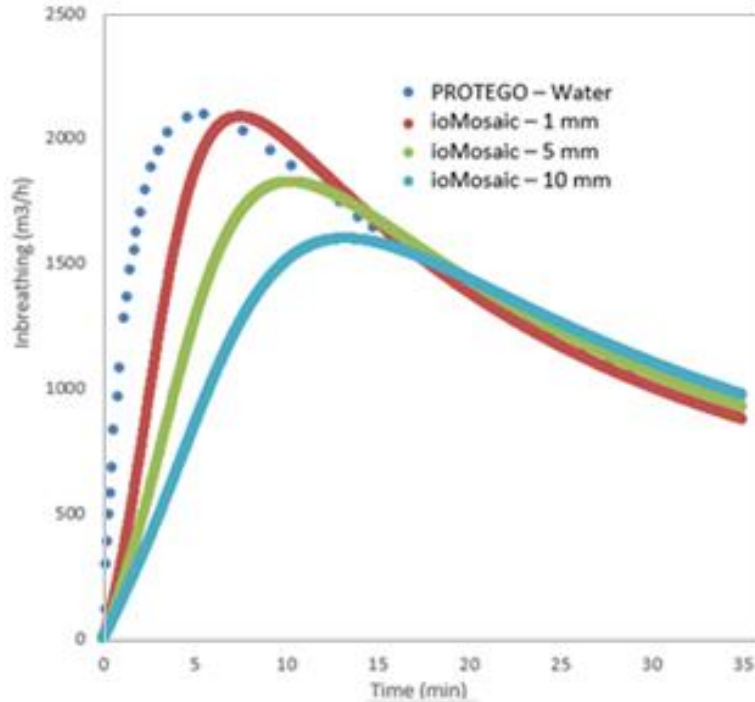

Figure 33: Vessel Segmentation in SuperChems Expert™

#### 4.3.2. ioMosaic© Assumptions in SuperChems Expert™

In order to better reflect the actual circumstances, the simulations performed in SuperChems accounted for both the wall heat capacity and the presence of a saturated two-phase mixture in the tank.

Referring back to Annex E of API 2000 [2], it is mentioned that, according to DIN 4119, a minimum wall thickness of 5 mm is to be used for all tank diameters less than or equal to 30 m. Since all the investigated tanks in this document have diameters less than 30 meters, the value of 5 mm for the shell-wall thickness was set as the default value for inbreathing predictions. Figure 34 below shows the impact of increasing the wall thickness on the inbreathing profile for a tank saturated with water vapor.



**Figure 34: Effect of Wall Thickness on Inbreathing (SuperChems).**

At the given initial conditions, 55°C and 0 psig, water exists as a subcooled liquid. By using a vapor-only model for condensable vapors, PROTEGO© completely neglects the phase envelope and assumes that water exists as a pure vapor. To address this issue, the simulations performed using SuperChems Expert™ were done using the two-phase model which primarily accounts for the vapor-liquid equilibrium. This model, however, requires the tank to be padded by nitrogen gas in order to achieve a saturated mixture condition at 55°C and 0 psig. It should be noted that SuperChems Expert™ vapor model was used to reproduce PROTEGO©'s condensable vapor inbreathing profiles and the results can be found in Appendix C.

### 4.3.3. ioMosaic SuperChems Models Versus PROTEGO©

The following section covers the replication of the PROTEGO© inbreathing models for dry air and water vapor using SuperChems Expert™.

#### 4.3.3.1. Model Results of Tank Filled With Dry Air

Since this is a non-condensable vapor, the “Vessel Containing Vapor (Dynamic)” model was used in SuperChems Expert™. The tank used was Fullarton’s tank of 3,978 m<sup>3</sup> capacity (H = 12m; D = 20m; s = 5mm). The tank was filled with dry air, therefore, the mixture inside the tank was composed of 79 mol% Nitrogen and 21 mol% Oxygen. Air was inbreathed through an 8" ideal nozzle and the maximum pressure drop recorded was equal to -0.02 psig. The same values for the heat transfer coefficients as used by PROTEGO© where  $h_{\text{gas}} = 5 \text{ W/m}^2\text{K}$  and  $h_{\text{rain}} = 37 \text{ W/m}^2\text{K}$ .

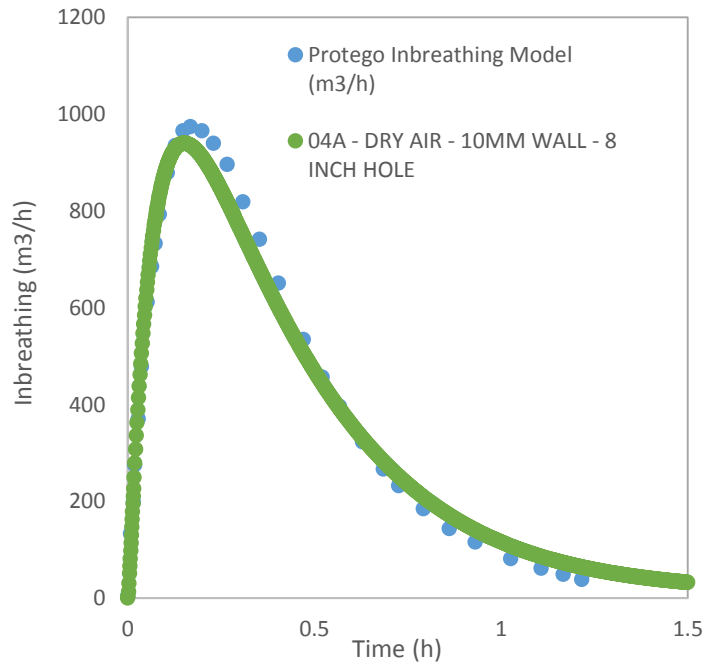
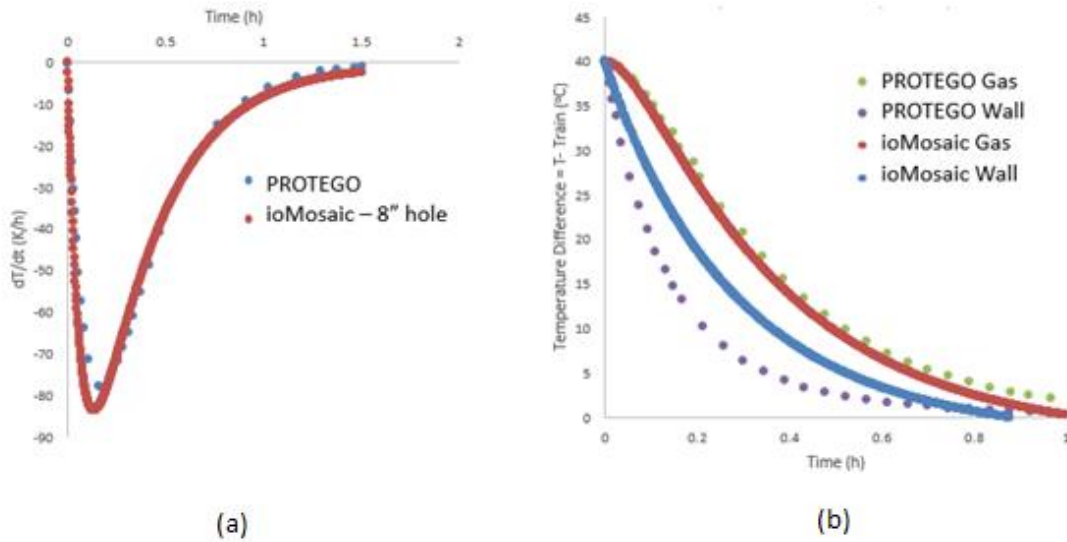

Figure 35: Inbreathing Profile of Air (SuperChems)

The inbreathing profile of PROTEGO©’s dry air tank is reproduced in Figure 35. The maximum recorded inbreathing from the SuperChems Expert™ simulation is around 940 Nm<sup>3</sup>/h. The deviation of the latter from  $\dot{V}_{max}$  predicted by PROTEGO© is – 4%.

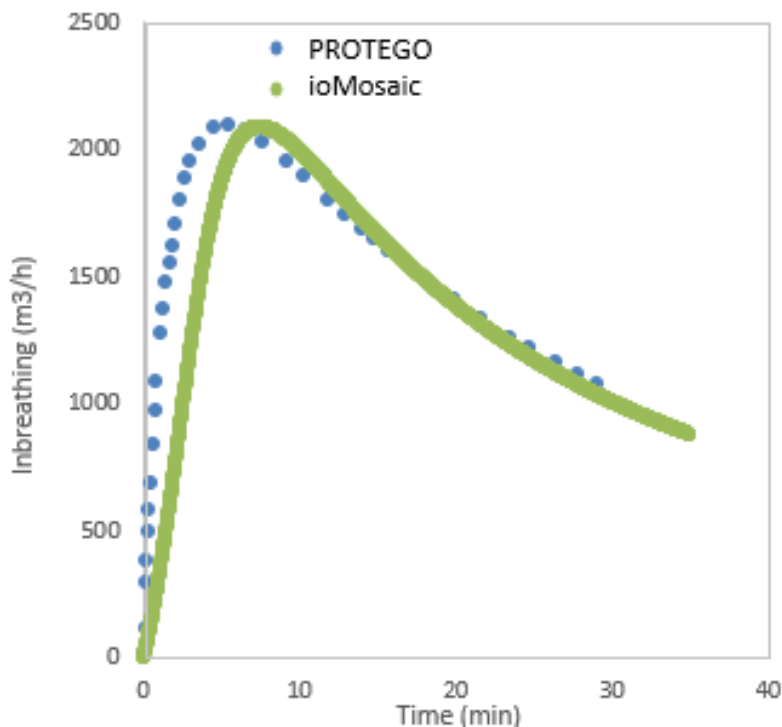

**Figure 36: (a) Temperature Change Rate versus Time. (b) Temperature Difference vs. Time of Air (SuperChems).**

The maximum absolute change rate of temperature using SuperChems Expert™ was found to be equal to  $|-78.3|$  K/h which is at a deviation of 8 % higher than that obtained by PROTEGO© as shown in Figure 36 (a). The temperature difference, which is the difference between the temperature of either the gas or the wall and the rain, is also plotted in Figure 36 (b). The gas temperature profile was accurately reproduced; the wall temperature profile, however, maintained the same curve shape as PROTEGO© but with a slower rate of temperature change.

#### 4.3.3.2. Model Results of Tank Saturated With Water Vapor

Figure 37 below shows the reproduced inbreathing profile using SuperChems Expert™ “Vessel Containing Two-Phase (Dynamic)” model for the 6,283 m<sup>3</sup> tank with a wall thickness of 1 mm. In order to achieve a saturated mixture at 55°C and 0 psig, the tank was padded with nitrogen gas and the mixture in the tank consisted of 74.7 mol% H<sub>2</sub>O and 25.3 mol% N<sub>2</sub>. The convective heat transfer used in this case had the same value set by PROTEGO© with  $h_{\text{gas}} = 5 \text{ W/m}^2\text{K}$  and  $h_{\text{rain}} = 50 \text{ W/m}^2\text{K}$ .



**Figure 37: Inbreathing Profile of Water Vapor (SuperChems)**

Air at normal conditions (0°C; 0psig) was inbreathed through a 10" hole and the maximum pressure drop recorded in the tank was equal to -0.026 psig. The maximum

inbreathing,  $\dot{V}_{max}$ , obtained from this model was 2,086 Nm<sup>3</sup>/h which is at a – 0.5% deviation from PROTEGO© value.

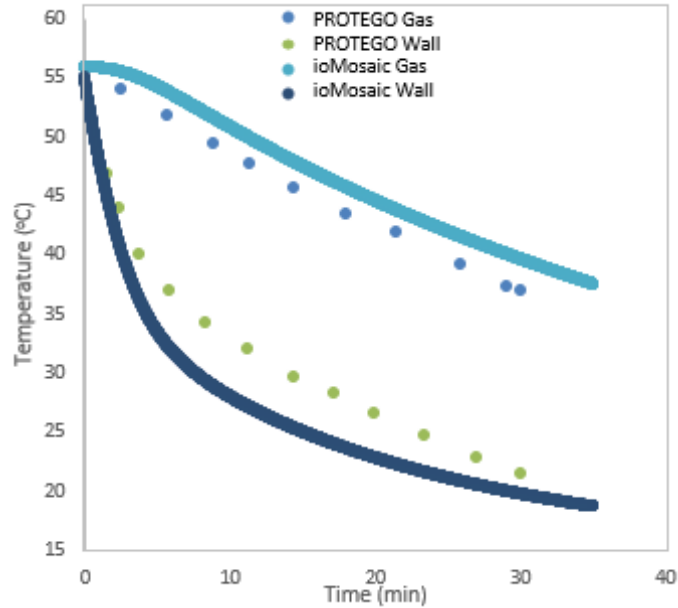

**Figure 38: Temperature Profile of Water Vapor (SuperChems)**

The replicated temperature profiles of the water vapor and the wall, shown in Figure 38 above, illustrate good agreement with PROTEGO©'s results. It should be noted that the SuperChems Expert™ model uses a shell wall thickness of 5 mm as the basis for inbreathing-requirement calculation and it was found that the adequate value for  $h_{gas}$  should be 20 W/m<sup>2</sup>K instead 5 W/m<sup>2</sup>K for water vapor. The inbreathing and temperature profile for the 5 mm wall thickness can be found in Appendix D.

Simulations were also performed for each of methanol, ethanol, heptane, and decane vapors where the successful reproduction of the PROTEGO© results was achieved. The corresponding inbreathing and temperature profiles for these vapors can be found in Appendix D as well.

It is concluded that SuperChems Expert™ model is capable of reproducing the data and is deemed as a valid model for calculating the inbreathing requirements of storage tanks for different types of services.

#### 4.3.4. Examination of the Inside Heat Transfer Coefficient, $h_{\text{gas}}$ , According to Vapor Type

PROTEGO© used  $h_{\text{gas}} = 5 \text{ W/m}^2\text{K}$  and  $h_{\text{rain}} = 50 \text{ W/m}^2\text{K}$  for all their inbreathing models of condensable vapors. However, using the given values unchanged in the SuperChems Expert™ model generated inadequate inbreathing profiles for most vapors and that is due to the fact that SuperChems Expert™ and PROTEGO© models are very different when it comes down to vapor-liquid interactions (refer to Section 4.3.1 and 4.3.2. for details).

$h_{\text{gas}}$  was adjusted for each type of condensable vapor in order to reproduce the PROTEGO© inbreathing results. Table 13 summarizes the values of  $h_{\text{gas}}$  used in the two-phase model for a tank-wall thickness of 5 mm. These results show that condensation “enhances” heat transfer thus providing evidence that use of constant heat transfer coefficients for the gas side will deliver incorrect relief device sizes.

**Table 13: Adjusted Values for  $H_{\text{gas}}$  for SuperChems Expert™ Two-Phase Model**

$h_{\text{gas}}$ (W/m <sup>2</sup> K)	Wall Thickness = 5 mm
Methanol	40
Ethanol	30
Water	20
Heptane	5
Decane	7



#### 4.4. API 2000 Performance

The maximum inbreathing values,  $\dot{V}_{max}$ , obtained from the SuperChems Expert™ models for each case were compared to those obtained using the API 2000 thermal inbreathing equation, Equation (1), to assess whether or not the API 2000 inbreathing estimates are conservative.

Since all the vapors investigated (methanol, ethanol, water vapor, etc.) do not have vapor pressures higher than hexane, their vapor pressure was classified as “Similar to Hexane”. The storage temperature of the gas is 55°C, which is greater than 25°C, so according to Table 1, the C-factor has a value of 5. The storage tanks in this study were all uninsulated, hence, the insulation reduction factor  $R_i$  has a value of one. The API 2000 inbreathing equation used for this case now becomes:

$$\dot{V}_{IT} = 5 V_{tk}^{0.7} \quad (49)$$

In order to determine whether the API 2000 inbreathing relief requirement is adequate, a deviation percentage of the API 2000  $\dot{V}_{max}$  prediction from the simulated (or experimental) results is computed as follows:

$$\% \text{ Deviation} = \frac{\dot{V}_{max,SC} - \dot{V}_{max, API 2000}}{\dot{V}_{max, API 2000}} \times 100 \quad (50)$$

Where  $\dot{V}_{max, API 2000}$  = Maximum inbreathing obtained  
from Equation (49)

$\dot{V}_{max,SC}$  = Maximum inbreathing from  
SuperChems Expert™ models

#### 4.4.1. PROTEGO© Inbreathing Model

Two different tanks were used to reproduce PRTOEGO©'s model: 3,978 m<sup>3</sup> for dry air and 6,283 m<sup>3</sup> for the condensable vapors. Replacing the tank volumes in Equation (49) results in a maximum inbreathing,  $\dot{V}_{max}$ , of 1,655 Nm<sup>3</sup>/h for dry air and 2,278 Nm<sup>3</sup>/h for condensable vapors. Table 14 summarizes the percentage deviation of the API 2000  $\dot{V}_{max}$  for different types of vapors.

**Table 14: Inbreathing Requirements of PROTEGO©'s Tank According to API 2000.**

Vapor	$V_{max, SC}$ (Nm <sup>3</sup> /h)	$V_{max, API 2000}$ (Nm <sup>3</sup> /h)	% Deviation
Methanol	3,818	2,278	+68
Ethanol	2,757	2,278	+21
Heptane	1,745	2,278	-23
Water	2,175	2,278	-5
Decane	1,419	2,278	-38
Air	940	1,655	-59

It can be seen that the API 2000 method has a conservative prediction of maximum inbreathing for dry air, heptane, decane, and water vapor services. However, the API 2000 method underpredicts the relief requirement for the inbreathing of a tank saturated with methanol and ethanol by up to 68%.

#### 4.4.2. Large Scale Data (Sigel and Holtkoetter)

Equation (49) applies to the large scale data tanks as well for the same reasons mentioned in the section above. *Sigel et al.* [6] used a tank volume of 600 m<sup>3</sup>, which when replaced in Equation (49), results in a maximum inbreathing value of 440 Nm<sup>3</sup>/h. Holtkoetter [7] used a smaller tank with a capacity equal to 1.18 m<sup>3</sup> which results in a maximum inbreathing rate of 5.6 Nm<sup>3</sup>/h according to the API 2000 method.

**Table 15: Inbreathing Requirements for the Large Scale Experiments According to API 2000.**

Vapor	$\dot{V}_{max, SC}$ (Nm <sup>3</sup> /h of air)	$\dot{V}_{max, API 2000}$ (Nm <sup>3</sup> /h of air)	% Deviation
Sigel Air	104	440	-76
Holtkoetter Water	13	5.6	+132
Holtkoetter Isopropanol	13.6	5.6	+143
Holtkoetter Methanol	20.9	5.6	+273

Table 15 compares  $\dot{V}_{max}$  using the API 2000 method to the actual recorded  $\dot{V}_{max}$  values during the experiments. The API 2000 inbreathing prediction is conservative for Sigel's empty tank. On the other hand, API 2000 inbreathing prediction underpredicts for water, isopropanol, and methanol vapors in Holtkoetter's tank where the deviation percentage is between 130% and 275%.

This supports the need for an updated standardized method for adequate prediction of the relief requirements of storage tanks experiencing thermal inbreathing.

#### **4.5. Impact of The Solar Flux on In/Out-breathing**

The solar radiation that the storage tanks are exposed to varies with the geographical location. During times of high solar radiation, the wall temperature of a tank situated in Saudi Arabia will be higher as compared to the wall temperature of a tank located in Canada. This difference in the climatic conditions greatly affects both the normal out-breathing and inbreathing processes which will be reviewed in this section.

API 2000 divides the climatic region into three zones according to the latitude: below 42°, between 42° and 58°, and above 58° (Table 1). Two locations were selected for this investigation: Montreal, Canada with a latitude of 45.5° and Jubail City, Saudi Arabia with a latitude of 27.1° [10]. The outer-wall emissivity of dirty aluminum bronze is equal to 0.6 was used for the tanks as specified in Annex E of API 2000 [2].

##### **4.5.1. SuperChems-Model Results**

Sigel's 600 m<sup>3</sup> tank [6] was used for this simulation and the breathing profile was predicted for a duration of 24 hours. The simulations were specified to use the solar radiation data of July 29, 2015 from 12:00 AM till 11:59 PM. Three types of finishing paints of different values for emissivity [4] were examined in this study:

1. Clean white paint:  $\epsilon = 0.4$
2. Dirty Aluminum Bronze:  $\epsilon = 0.6$
3. Black paint:  $\epsilon = 0.96$

The tank was installed with a 0.5" rupture disc with a set pressure of 0.001 psig in order to protect the vessel against overpressure. The tank was filled with dry air for this

model, therefore the SuperChems Expert™ “Vapor Model” was used with a mixture of 0.79 mol% Nitrogen and 0.21 mol% Oxygen. The shell wall thickness used was equal to 5 mm which is the minimum wall thickness for tanks with diameters less than 30 meters as specified by DIN 4119.

The worst-case scenario that will result in the most conservative inbreathing prediction will be having a sudden rainstorm on a hot summer day. Therefore, the modeled tank was exposed to a two-hour rainfall at the time of highest solar radiation.

#### ***4.5.1.1. SuperChems Model for Montreal, Canada***

In order to predict the solar flux distribution using SuperChems, three parameters must be specified: the actual date (July 29, 2015), the coordinates of the location (45.5° N, 73.554° W), and the cloud cover percentage (0%). After specifying these parameters, the solar flux distribution was obtained and shown in Figure 39 below.

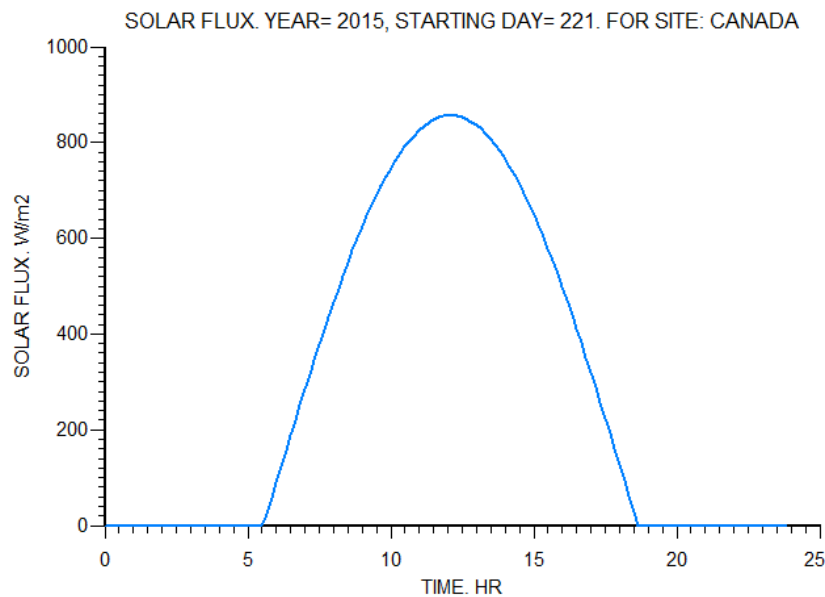

**Figure 39: Solar Flux Distribution for Canada using SuperChems Expert™**

It can be seen that the maximum solar flux is equal to  $860 \text{ W/m}^2$  and occurs at time  $t = 12$  hours. The latter time will be used as the onset time of the rainstorm. It should be noted that  $t = 0$  h denotes the start of the day at 12:00 AM (local time).

Figure 40 illustrates both the gas temperature and in/out-breathing profile of the tank situated in Canada. SuperChems computes the inbreathing and out-breathing rates as the rate of volume change of the contents,  $dV/dt$ , in the tank at normal conditions ( $0^\circ\text{C}$ ; 0 psig). The positive change in volume rate ( $+dV/dt$ ) in Figure 40 denotes inbreathing, since an additional volume of air is introduced to the tank. On the other hand, the negative change ( $-dV/dt$ ) denotes out-breathing, since air is escaping the tank.

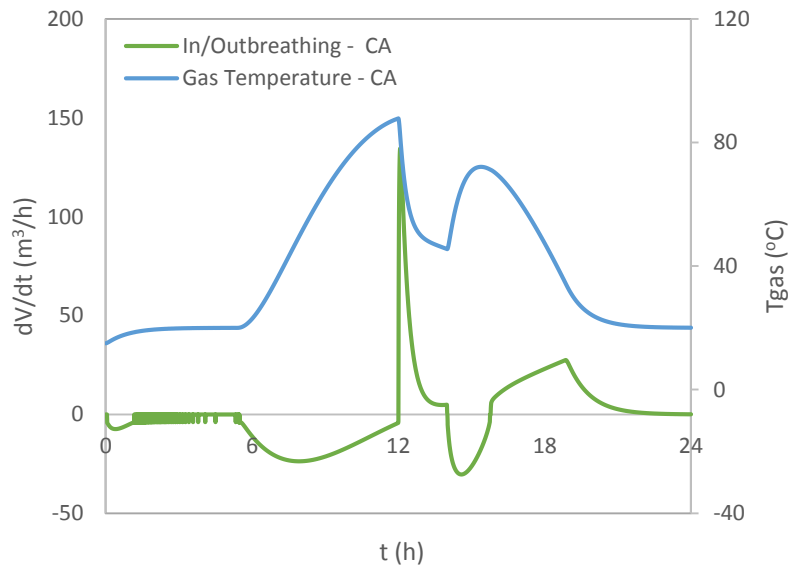

**Figure 40: Gas Temperature and Inbreathing Profile for Aluminum Bronze Tank in Montreal, Canada.**

At  $t = 17$  h, the maximum gas temperature in the tank is  $122.6^\circ\text{C}$  due to the prolonged solar exposure. Rain at  $15^\circ\text{C}$  and  $0.39 \text{ inch/h}$  ( $h_{\text{rain}} = 13.2 \text{ W/m}^2\text{K}$ ) intensity starts at  $t = 12$  h and lasts for 2 hours. Following API 2000 Annex E assumptions [2] for tank

cooling by rain, the heat transfer coefficient between the gas and inside wall was set to  $h_{\text{gas}} = 5 \text{ W/m}^2\text{K}$ . The gas temperature decreases from  $122.6^\circ\text{C}$  to  $64.7^\circ\text{C}$  leading to a pressure drop inside the tank, which in turn becomes the driving force for the thermal inbreathing. The maximum inbreathing rate for this case is equal to  $166.9 \text{ m}^3/\text{h}$ . The same model was tested for the three types of paints and the corresponding breathing results are summarized in the table below.

**Table 16: Maximum Inbreathing, Out-breathing, and Solar Radiation - Montreal, Canada.**

<b>Paint (Emissivity <math>\epsilon</math>)</b>	$\dot{V}_{IT,max}$ Nm <sup>3</sup> /h	$\dot{V}_{OT,max}$ Nm <sup>3</sup> /h	$Q_{solar}$ kW
White (0.4)	123.9	27.9	5.3
Aluminum Bronze (0.6)	134.5	30.3	6.7
Black (0.96)	142.7	31.8	8.5

It can be seen that as the emissivity of the coating increases, the amount of solar radiation absorbed by the walls of the tank increases. Higher wall temperature cause a higher temperature gradient between the walls and the rain (or ambient) temperatures which results in a stronger driving force for the breathing processes. Using a paint finishing other than API 2000 Aluminum bronze yields a  $\pm 5\%$  error in the expected inbreathing and out-breathing rates. The graphed results for Table 16 can be found in Appendix E.

The same model was run for a different location: Jubail City, Saudi Arabia with coordinates ( $27.1^\circ \text{ N}$ ,  $49.37^\circ \text{ E}$ ). The results for Saudi Arabia location are listed under Appendix E for simplicity. The next section compares the inbreathing and out-breathing rates of both locations to determine the effect of geographical location.

#### 4.5.1.2. Canada versus Saudi Arabia Tank Inbreathing During a Sudden Rainstorm

Table below summarizes the tank inbreathing and out-breathing rates recorded for Montreal, Canada and Jubail City, Saudi Arabia in order to quantify the impact of the different climatic regions. The deviation percentage is calculated as follows:

$$\% \text{ Deviation} = \frac{\dot{V}_{\text{Saudi}} - \dot{V}_{\text{Canada}}}{\dot{V}_{\text{Canada}}} \times 100 \quad (51)$$

For the inbreathing rates, the tank in Saudi Arabia experienced a 1.7% higher inbreathing rate than the tank in Canada. This difference is minute due to the fact that both tanks were at a high, yet similar, temperatures at the time the rainstorm started (87.8°C for Canada; 101.3°C for Saudi). On the other hand, the deviation was more significant for the out-breathing rate where the tank in Saudi Arabia experienced around a 16.8% increase in the predicted out-breathing compared to Canada. This deviation is due to two factors: higher ambient temperature (30°C vs 20°C in Canada) and higher solar flux (986 W/m<sup>2</sup>K vs 860 W/m<sup>2</sup>K in Canada).

**Table 17: Maximum Inbreathing, Out-breathing, and Solar Heat Rate - Jubail City, Saudi Arabia.**

	Canada	Saudi Arabia	Deviation (%)
$\dot{V}_{IT,max}$ (Nm <sup>3</sup> /h)	134.5	148.4	10.3
$\dot{V}_{OT,max}$ (Nm <sup>3</sup> /h)	30.31	32.6	7.6

More work is required to understand the results of this model that will be addressed in future research. After assessing the breathing requirements, the final comparison to be



made, in the following section, is with the API 2000 equations to see if such setups are properly protected.

#### 4.5.2. Comparison to API 2000 Equations

The API 2000 inbreathing and out-breathing requirements were calculated using Equations (1) and (5), respectively. The tank is uninsulated i.e. the reduction factor  $R_i$  is equal to 1. The C-factor for inbreathing (Table 1) and Y-factor for out-breathing (Table 2) were determined using the latitude of each location. The gas inside the tank is dry air stored at a temperature of 15°C. The breathing results, according to API 2000, for each location are summarized in the table below.

**Table 18: API 2000 Breathing Requirements - Canada vs. Saudi Arabia.**

Location	Latitude	C	$\dot{V}_{IT} = C V_{tk}^{0.7}$	Y	$\dot{V}_{OT} = Y V_{tk}^{0.9}$
Montreal, Canada	45.5°	3	264.14 Nm <sup>3</sup> /h	0.25	79.12 Nm <sup>3</sup> /h
Jubail City, Saudi Arabia	27.1°	4	352.18 Nm <sup>3</sup> /h	0.32	101.27 Nm <sup>3</sup> /h

It can be concluded that the API 2000 relief equations are adequate for the Sigel empty tank tested in both Canada and Saudi Arabia. The API 2000 method's conservativeness ranges between 49% to 58% for inbreathing and 62% to 68% for out-breathing. It should be noted, however, that the service of the tank also plays an important role especially if the stored gas is condensable or not. As it was proven in the previous sections of this investigation, API 2000 may under estimate inbreathing rates for tanks with condensable gases against thermal inbreathing. Therefore, this investigation is applicable to empty storage tanks only.

#### **4.6. Impact of Wide Boiling Point Range Mixtures**

In order to study the impact of storing a wide-boiling-point range mixture on inbreathing, Holtkoetter's 1.18 m<sup>3</sup> tank was used [7]. Two mixtures were investigated here: 60 mol % water/40 mol% ethanol as the first mixture; 60 mol% gasoline/40 mol% ethanol as the second mixture. The resulting inbreathing profiles were then compared to the inbreathing profile of pure saturated water vapor determined experimentally by Holtkoetter [7].

The composition used for gasoline as defined in SuperChems consists of some of the major compounds found in fresh gasoline and is summarized in Table 19 below. It can be seen that this mixture has a wide boiling-point range between -0.5°C and 159.2°C.

**Table 19: Gasoline Composition [13].**

<b>Component</b>	<b>Mole Fraction</b>	<b>Normal Boiling Point (°C)</b>
n-Butane	0.1397	-0.5
Isopentane	0.1877	27.8
n-Pentane	0.1049	36.1
2,3-Dimethylbutane	0.1094	58.0
p-Xylene	0.1164	138.4
n-Propylbenzene	0.0903	159.2

The heat transfer coefficients used for this model were adopted from the SuperChems model of Holtkoetter's tank in Section 4.2 where  $h_{\text{gas}} = 30 \text{ W/m}^2\text{K}$  and  $h_{\text{rain}} = 601 \text{ W/m}^2\text{K}$ . The initial liquid level in the tank was set to 0.1% for both mixtures. In order

to achieve a saturated mixture condition at 55°C and 0 psig, the tank was padded with nitrogen gas. The saturated mixture composition after adding nitrogen is shown in the table below.

**Table 20: Saturated Mixture Molar Composition with Nitrogen Gas**

Mixture	Water/Ethanol	Gasoline/Ethanol
Water	0.355	-
Ethanol	0.237	0.236
Gasoline	-	0.352
Nitrogen	0.408	0.412

Both mixtures were simulated using the SuperChems Expert™ “Two-Phase Model” where the resulting inbreathing profiles are illustrated in Figure 41 below.

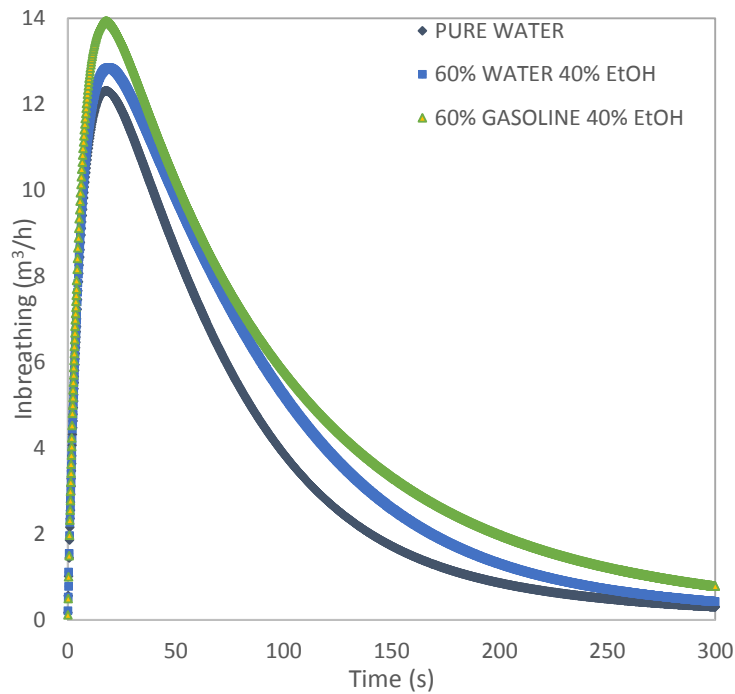
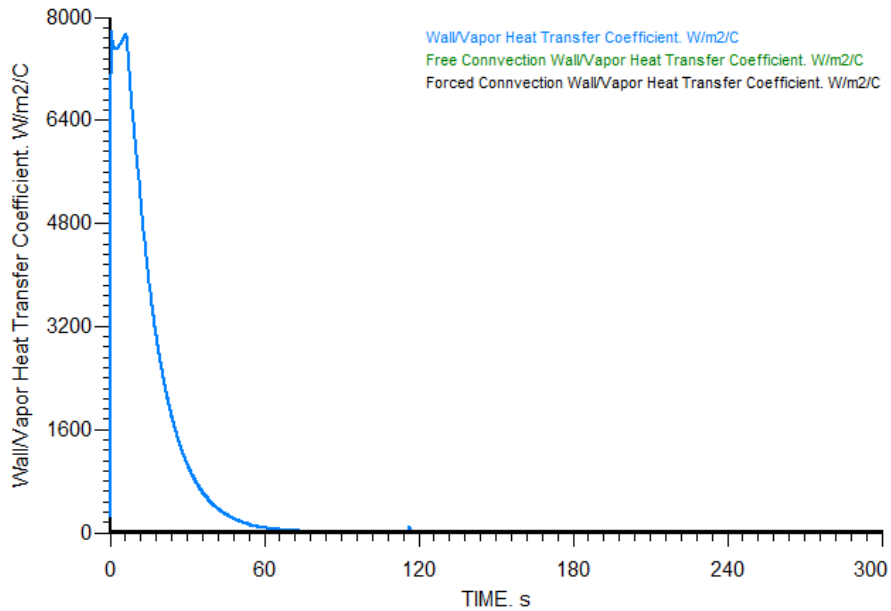

**Figure 41: Inbreathing Profile of Different Mixtures**

It can be seen from Figure 41 that both the water-ethanol and gasoline-ethanol mixtures caused higher inbreathing rates than that obtained from using pure water vapor. Using the gasoline-ethanol mixture resulted in a 13.25% higher inbreathing rate than pure water vapor whereas using the water-ethanol mixture caused a 4.45% higher inbreathing. This conforms to the fact that the more volatile the gaseous mixture is, the higher the thermal inbreathing will be due to the increased condensation.

The maximum inbreathing for Holtkoetter's tank (Table 15) using API 2000 is underpredicted by 150% for the gasoline-ethanol mixture and by 130% for the water-ethanol mixture; this means the tank will create a negative pressure which puts it at a risk of structural damage e.g. denting.

The key parameter in this model is the heat transfer coefficient of the free-convection between the gas mixture and the inner walls of the tank,  $h_{\text{gas}}$ . The value of  $h_{\text{gas}}$  used for this model was based on the mixture being pure water vapor ( $30 \text{ W/m}^2\text{K}$ ). Therefore, it is suspected that the adequate value for the mixtures'  $h_{\text{gas}}$  will be higher than  $30 \text{ W/m}^2\text{K}$ . Since the gasoline-ethanol mixture is more volatile than the water-ethanol mixture, its corresponding  $h_{\text{gas}}$  value must be higher than that of the latter.



**Figure 42:  $h_{\text{gas}}$  for pure water calculated using SuperChems.**

SuperChems Expert™ gives the users the option to either specify a fixed value for the heat transfer coefficient or to compute it dynamically using common heat transfer correlations. The latter option was used for the gasoline/ethanol mixture and the results are shown in Figure 42. The predicted  $h_{\text{gas}}$  had a maximum of the order of 8,000 W/m<sup>2</sup>K which is considered relatively high when compared to the value used in this model (30 W/m<sup>2</sup>K). The dynamically computed  $h_{\text{gas}}$  is a function of the condensation rate of the gaseous mixture. The condensation rate gradually increases as the rain starts to pour causing the walls to get colder and colder until a maximum condensation rate is reached. At this point, the walls have a very low temperature which results in maximum condensation and therefore a maximum  $h_{\text{gas}}$  that eventually leads to a maximum inbreathing rate. This method was not implemented in the current study but will be included as part of future work on the modeling of thermal inbreathing.

## 5.0 CONCLUSIONS

A dynamic simulation of the thermal inbreathing of low pressure storage tanks experiencing sudden change of weather conditions was performed using a SuperChems Expert™ model. This model was successful in reproducing results from large scale test data and other available models.

The validity of the heat transfer coefficients used by API 2000 was investigated. It was found that the gas/wall free-convection heat transfer coefficient,  $h_{\text{gas}} = 5 \text{ W/m}^2\text{K}$ , specified by API 2000 was adequate when the tank was empty. However, higher values were suggested for condensable gases and range between  $10 \text{ W/m}^2\text{K}$  to  $45 \text{ W/m}^2\text{K}$  depending on the type and volatility of the vapor. As for the rain/wall heat transfer coefficient, API 2000's value of  $5,000 \text{ W/m}^2\text{K}$  proved to be too conservative which leads to overdesigning the relief device. Suggested values for the rain/wall heat transfer coefficient were in the range of  $12$  to  $600 \text{ W/m}^2\text{K}$ . It should be noted that both heat transfer coefficients,  $h_{\text{gas}}$  and  $h_{\text{rain}}$ , are found using an iterative approach in SuperChems Expert™.

The impact of the solar radiation determined by the geographical location of the tank was assessed. The inbreathing and out-breathing of the same empty tank in Canada and Saudi Arabia was studied. It was found out the inbreathing differs by 10% whereas out-breathing differs by 8% between the two locations. Compared to API 2000, relief predictions were suitable for a tank filled with dry air whereas the relief device for non-condensable vapors was overdesigned by up to 78%. More work is recommended to examine this large variation. Also, note that caution must be exercised if the service of the tank changes to a condensable gas instead of dry air. Moreover, this type of study combined

with location-specific meteorological data can predict the annual/seasonal fugitive tank emissions (due to the natural rise and fall of temperature during day and night) that should be reported to the Environmental Protection Agency (EPA).

Two wide-boiling point mixtures were examined in order to quantify the impact of storing such mixtures on the thermal inbreathing. The first mixture had a molar 60% water 40% ethanol. The second mixture had a molar 60% gasoline 40% ethanol. The inbreathing of the gasoline/ethanol mixture recorded the highest inbreathing rate when compared to the water/ethanol and pure water vapor systems. The API 2000 method predictions were incapable of protecting the storage tank from the vacuum caused by the condensation and contraction of both mixtures as was shown using the proposed SuperChems model.

The inbreathing requirements calculated according to API 2000 equations proved to be adequate for non-condensable gases but tend to underpredict the maximum inbreathing rate for some condensable vapors such as methanol, ethanol and isopropanol.

SuperChems Expert™ is an adequate tool for designing relief devices to protect storage tanks from overpressure and vacuum due to thermal out-breathing and inbreathing. However, it is recommended that large scale experimental work be conducted to enhance the current models. It is also recommended that the target thermodynamic variables, such as the heat transfer coefficient between the walls and the vapor or the overall rain/wall heat transfer coefficient, be improved.

## 6.0 REFERENCES

- [1] Kletz, T. "What Went Wrong, Case studies of process plant disasters", 4th ed., Elsevier, Butterworth-Heinemann, 1999.
- [2] API Standard 2000, *Venting Atmospheric and Low-Pressure Storage Tanks*, 7th Edition, March 2014.
- [3] API Standard 620, *Design and Construction of Large, Welded, Low-Pressure Storage Tanks*, 12th Edition, October 2013.
- [4] Foerster, H., K. Schampel, and H. Steen, "*Atmungsvorgänge infolge von Witterungseinflüssen an Lagertanks für brennbare Flüssigkeiten*", Physikalisch Technische Bundesanstalt (PTB) W-22. Braunschweig Univ. Phys.-Tech. Bundesanst, 1984.
- [5] Fullarton, D., J. Evripidis and E.U. Shclünder, "*Influence of Product Vapour Condensation on Venting of Storage Tanks*", Institut für Thermische Verfahrenstechnik, Universität Karlsruhe (TH), 1986.
- [6] Sigel, R., B. Kuxdorf, R. Meiss and H. Schwarz, "*Praktische und theoretische Untersuchung der Beatmung von Festdachtanks*". Chemie Ingenieur Technik, 55.5, pp. 377-379, 1983.
- [7] Holtkötter, T., J. Shang and H.G. Scheckerm "*Behälteratmung - Experimentelle Untersuchungen und Entwicklung eines Vorhersagemodells*" (Master Thesis), 1995.
- [8] Scholz, R., and R. Weber. "*Cooling Down Industrial Tanks*". Prepared for PROTEGO Braunschweiger Flammenfilter at API 2000 Meeting Presentation, Fall 2010.
- [9] Salatino, P., G. Volpicelli and P. Volpe. "*On the design of thermal breathing devices for liquid storage tanks*", Process Safety and Environmental Protection, 77.6, pp. 354-359, 1999.
- [10] ioMosaic Corporation, SuperChems Expert™ component of Process Safety Office™, Available at <http://www.ioiq.com/PSO.aspx>, 2015.
- [11] D. Brooks "*Thermal Inbreathing Requirements of Low Pressure Storage Tanks at Elevated Temperatures*". Lloyd's Register Energy Americas, Inc. Spring DIERS Users Group Meeting, Presentation, May 2012.
- [12] Xiao, B., Wang, G. et al. "*An Experimental Study Of Heat Transfer During Forced Air Convection*". Journal of Materials Engineering and Performance, 20.7, pp. 1264-1270, 2011.
- [13] Unknown. Ground Water Management Review. p. 167. Spring, 1990.



## **7.0 APPENDICES**

**Appendix A**  
**Sigel [6] Theoretical Model**

Sigel compared the actual measurements of the inbreathing with theoretical values from the Hoescht-Gleichung equation given below, the same model that PROTEGO used:

$$\dot{V}_{Hoescht} = V_B \frac{\Delta T_0}{T_{BO}} \frac{b}{\lambda} \left[ \exp\left(\frac{\lambda - a}{2} \tau\right) - \exp\left(\frac{-\lambda - a}{2} \tau\right) \right] \quad (\text{A.1})$$

$$a = A \left( \frac{\alpha_B}{C_B} + \frac{\alpha_B + \dot{m}_{eff} c_w k_1}{C_E} \right) \quad b = A^2 \frac{\alpha_B \dot{m}_{eff} c_w}{C_B C_E} k_1 \quad (\text{A.2}), (\text{A.3})$$

$$k_1 = \frac{\alpha_w}{\alpha_w + \dot{m}_{eff} c_w} \quad \lambda = \sqrt{a^2 - 4b} \quad (\text{A.4}), (\text{A.5})$$

Where:  $\dot{V}_{Hoescht}$  = Maximum thermal inbreathing (m<sup>3</sup>/h)

$\tau$  = Time (h)

$V_B$  = Volume occupied by the gas (m<sup>3</sup>)

$\Delta T_0$  = Initial temperature difference between gas and rain (K)

$T_{BO}$  = Initial gas temperature (K)

$\lambda, b, a$  = Integration constants

The Hoescht equation neglects the heat capacity of the roof material, assumes a uniform water flow (cooling rate) and assumes uniform heat transfer over the entire surface area of the tank. It should be noted that the effective rain intensity,  $\dot{m}_{eff}$ , is calculated according to Equation (36) to account for the wind speed and direction. The time,  $\tau_{max}$  in hours, that maximizes the thermal inbreathing rate was obtained by setting the first derivative of Equation (A.1) to zero and the resulting expression is:

$$\tau_{max} = \frac{1}{\lambda} \ln \left( \frac{a + \lambda}{a - \lambda} \right) \quad (\text{A.6})$$

## **Appendix B**

### **Holtkoetter's Tank Simulation Results in SuperChems Expert™**

The results from the SuperChems “Two-Phase Model” for Holtkoetter’s tank using both water vapor and methanol are summarized below.

### **B.1. Simulation Results of Tank Saturated with Water Vapor**

A mixture of 73 mol% water and 27 mol% nitrogen was used to achieve a saturated mixture at 55°C and 0 psig. Figure B.1 illustrates the inbreathing profile for two different values of the free-convection heat transfer coefficient of the gas inside the tank. Using  $h_{\text{gas}} = 5 \text{ W/m}^2\text{K}$  resulted in the red curve of Figure B.1 which underpredicts the measured maximum inbreathing value by -62.2 %.

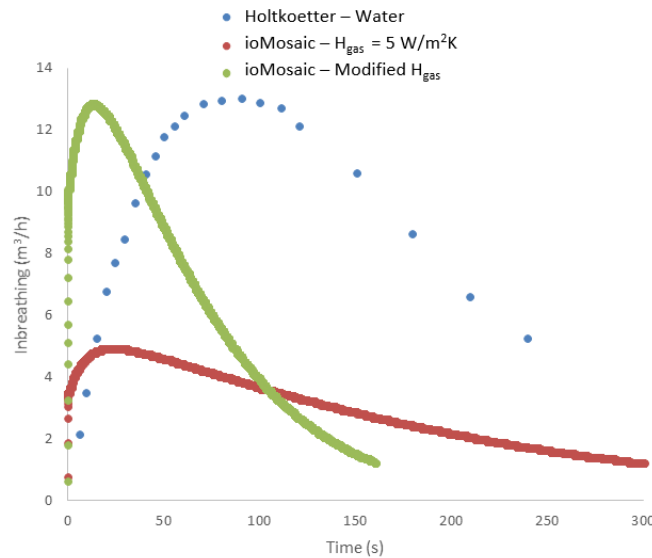

**Figure B.1: Water Vapor Inbreathing Profile (SuperChems)**

In order to match the simulation results with the experimental ones, a higher value for  $h_{\text{gas}}$  equal to 30  $\text{W/m}^2\text{K}$  was used. The latter value resulted in the green inbreathing curve (green) in Figure B.1 which matched the experimental value for maximum inbreathing and had a deviation of -1.7% which lies with the  $\pm 5\%$  error margin. The

inbreathing profiles obtained from the SuperChems-model are much faster than the experimental profile where the time to achieve maximum inbreathing was at  $t = 13.64$  seconds. It should be noted, however, that the only important value extracted from this model is the maximum inbreathing which will be the basis to designing the adequate relief device.

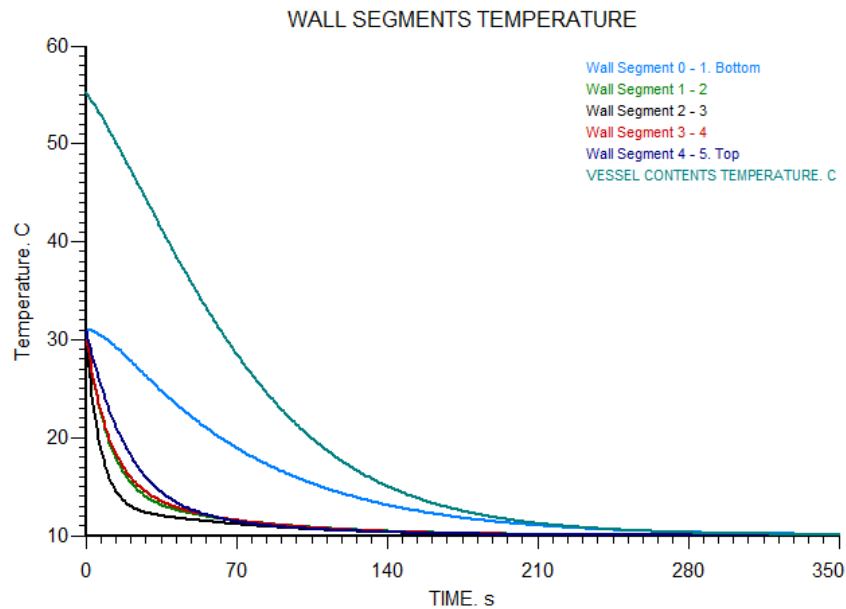
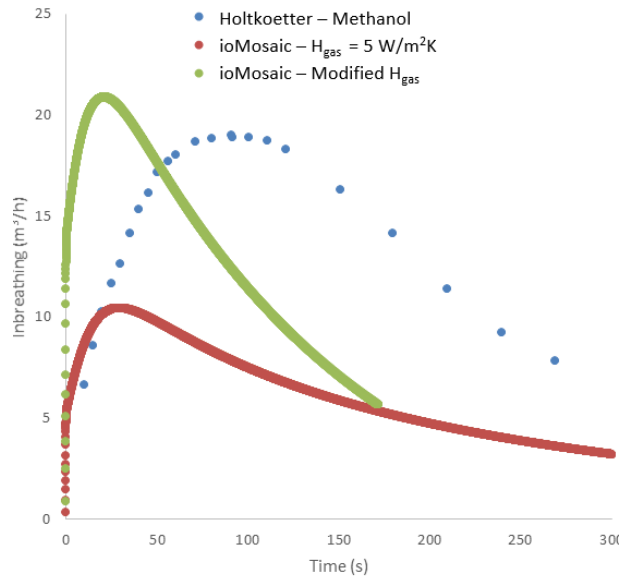

**Figure B.2: Water Vapor Temperature Profile (SuperChems)**

The temperature profile obtained from the SuperChems-model can be seen in Figure B.2 where the temperature profile of the vessel contents in addition to the 5 wall segments is shown. The temperature of the top wall segment (i.e. roof) experiences the fastest cooling since it is in direct contact with the rain whereas the temperature of the tank bottom has the slowest temperature decay. This is due to the fact that the tank bottom does not have contact with the rain since the tank foundations are deep in the ground.

## **B.2. Simulation Results of Tank Saturated with Methanol Vapor**

A mixture of 81.5 mol% methanol and 18.5 mol% nitrogen was used to achieve a saturated mixture at 55°C and 0 psig. Figures B.3 and B.4 illustrate the inbreathing and temperature profiles for methanol vapor. The modified  $h_{\text{gas}}$  had a value of 30W/m<sup>2</sup>K for this case.



**Figure B.3: Methanol Vapor Inbreathing Profile (SuperChems)**

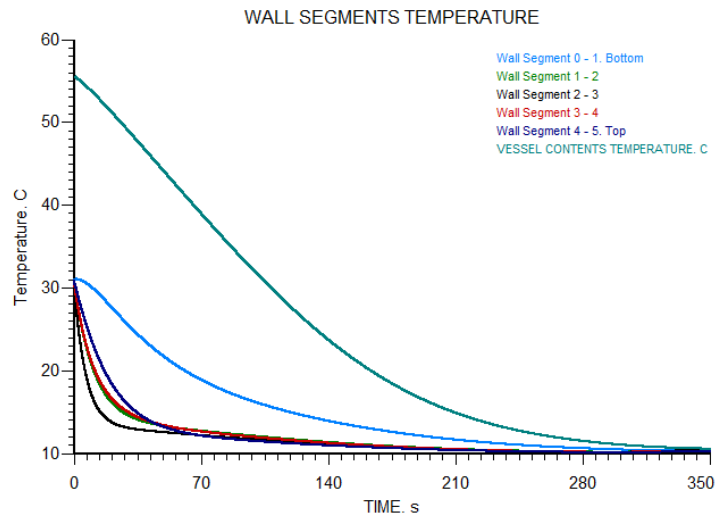

**Figure B.4: Methanol Vapor Temperature Profile (SuperChems)**

## Appendix C

### **Reproduction of PROTEGO© Condensable Vapor Models using SuperChems Expert™ Vapor Phase Dynamic Model**



Since PROTEGO© used a single-phase model for their simulation, the SuperChems “Vapor Phase Dynamic Model” was used to reproduce the data. The table below summarizes the values used for the  $h_{\text{gas}}$  according to the type of vapor used.

**Table C.1: Adjusted  $h_{\text{gas}}$  for Different Types of Vapor**

Vapor Type	$h_{\text{gas}}$ (W/m <sup>2</sup> K) used in SuperChems
Methanol	65
Ethanol	20
Water	5
Heptane	25
Decane	17

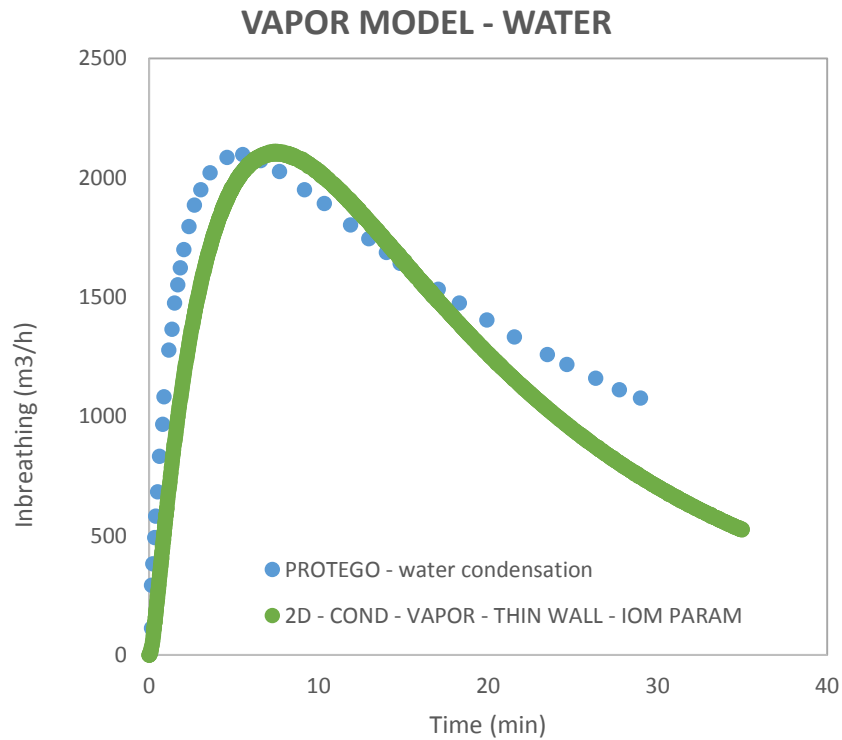

**Figure C.1: Inbreathing Profile for Water Vapor Using SuperChems Vapor Model**

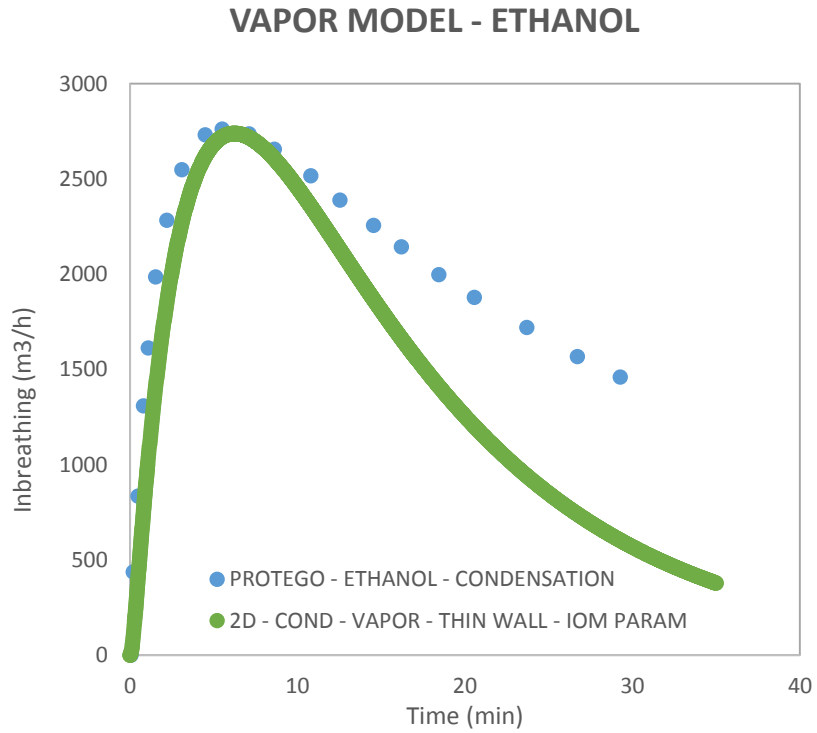

**Figure C.2: Inbreathing Profile for Ethanol Vapor Using SuperChems Vapor Model**

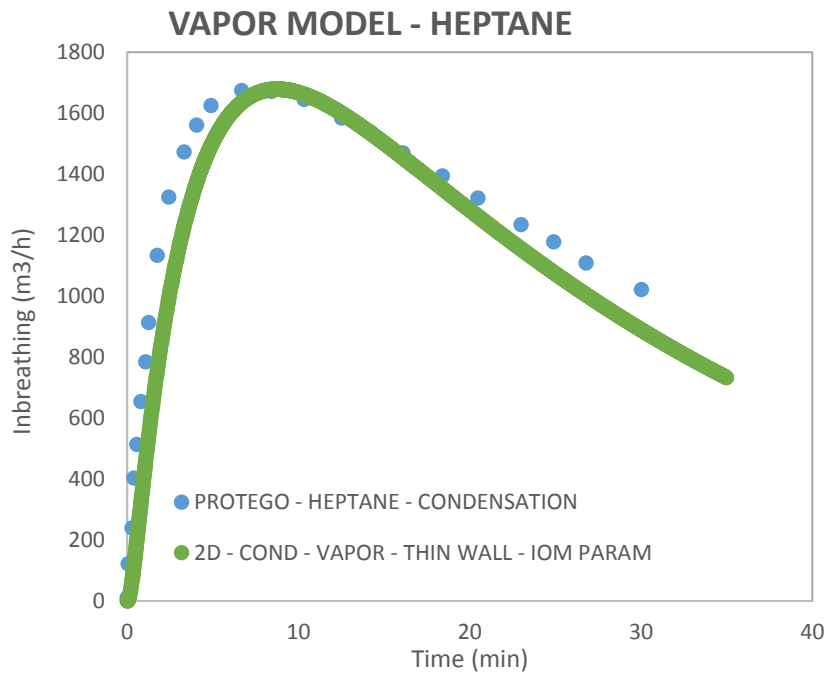

**Figure C.3: Inbreathing Profile for Heptane Vapor Using SuperChems Vapor Model**

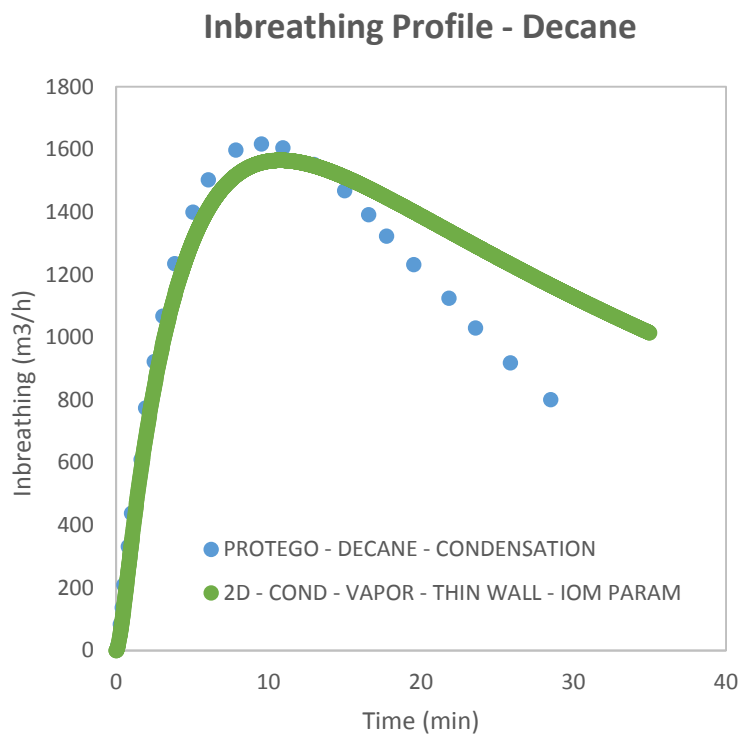

**Figure C.4: Inbreathing Profile for Decane Vapor Using SuperChems Vapor Model**

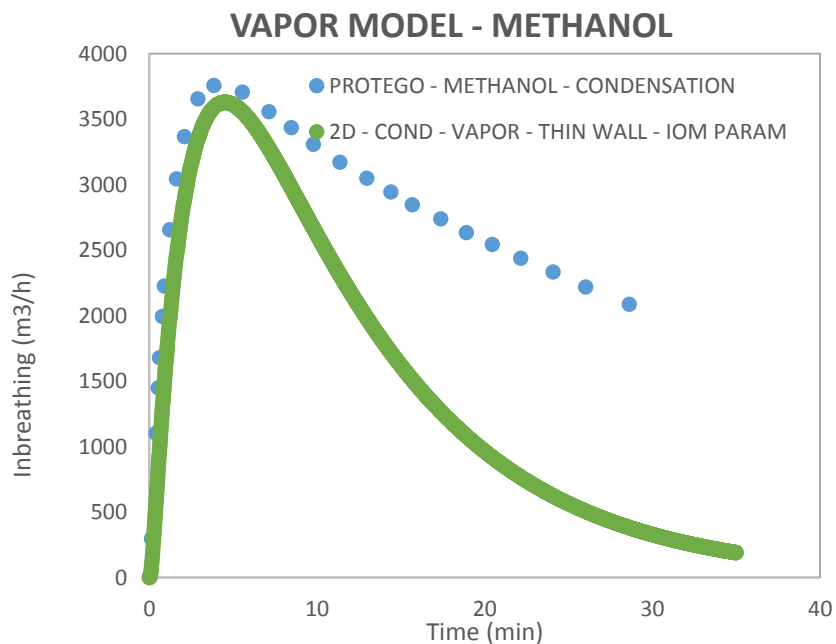
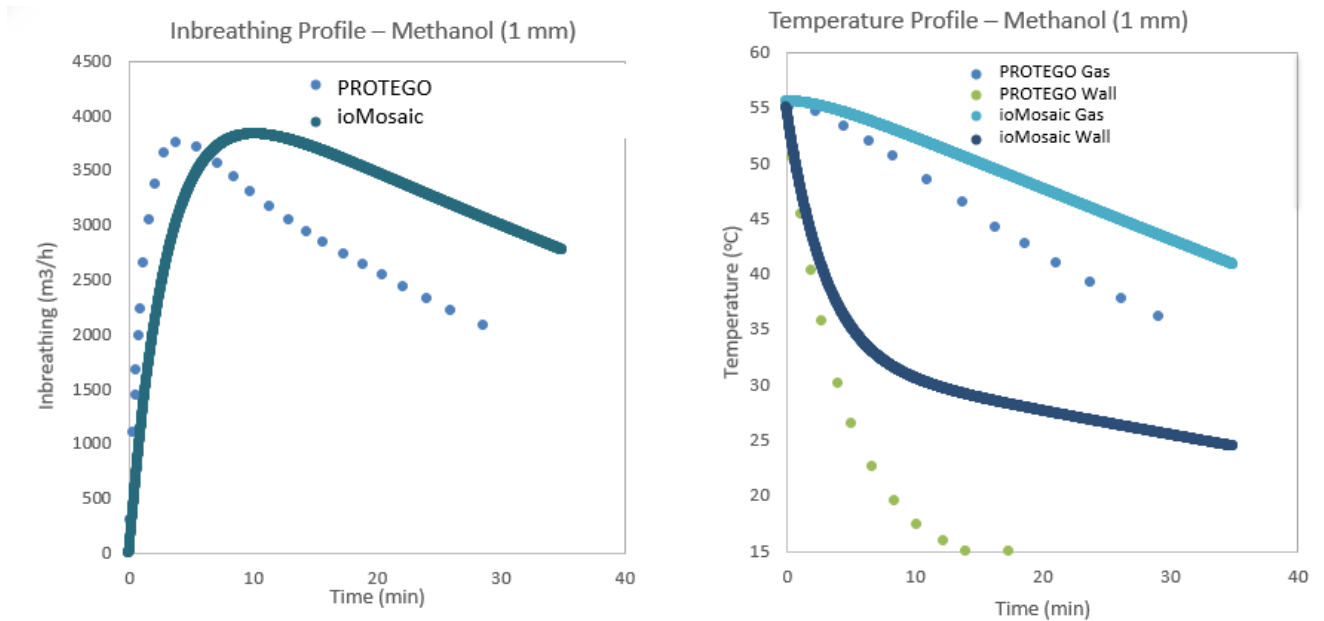

**Figure C.5: Inbreathing Profile for Methanol Vapor Using SuperChems Vapor Model**

## **Appendix D**

### **Reproduction of PROTEGO© Condensable Vapor Models using SuperChems Expert™ Two-Phase Dynamic Model for 1 mm and 5 mm Wall Thickness**

The inbreathing and temperature profile of PROTEGO®'s model were reproduced using the “Two-Phase Dynamic Model” in SuperChems. The results for the five different type of vapors are shown using two wall thicknesses: 1 mm and 5 mm.



**Figure D.1: Inbreathing and Temperature Profile for Methanol Vapor – 1 mm Wall Thickness**

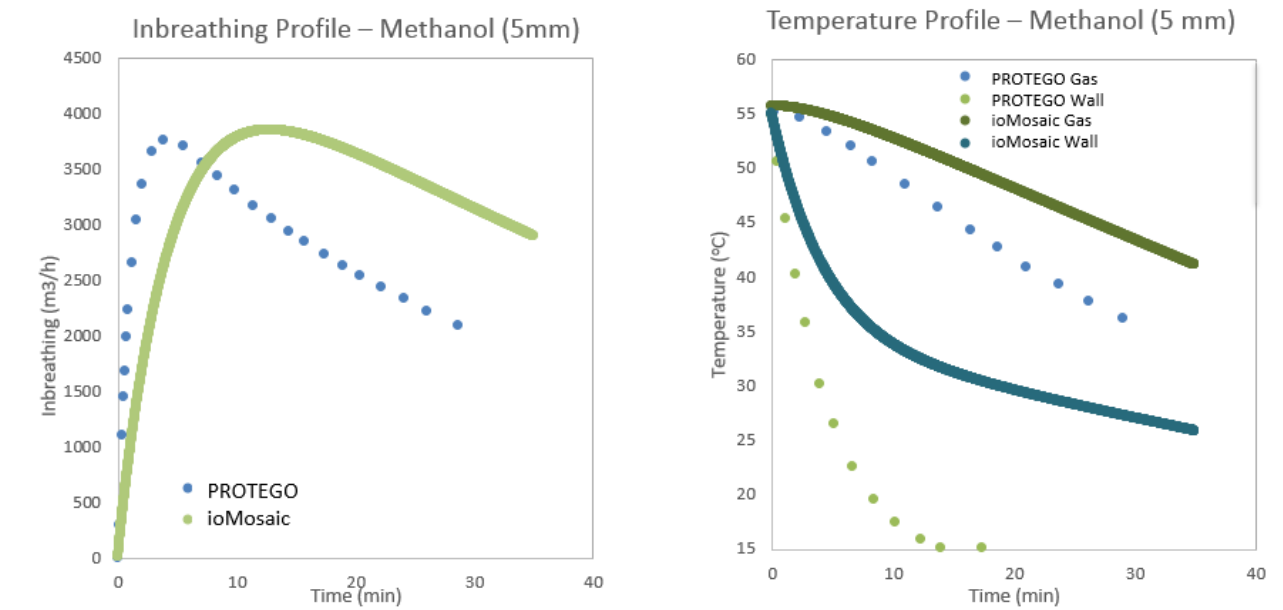

**Figure D.2: Inbreathing and Temperature Profile for Methanol Vapor – 5 mm Wall Thickness**

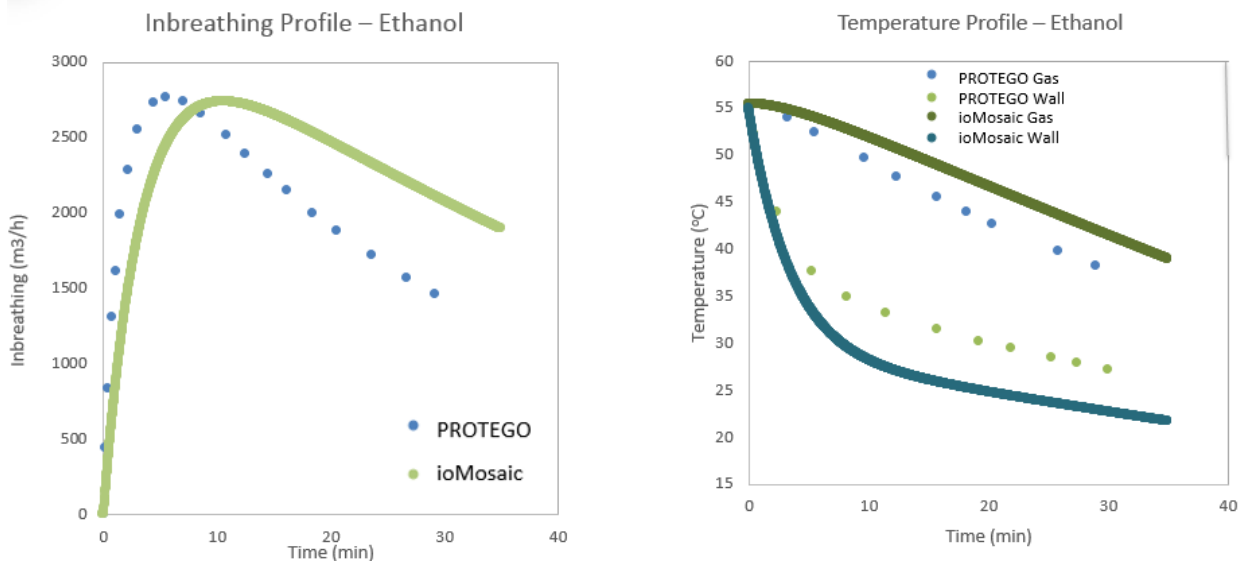

**Figure D.3: Inbreathing and Temperature Profile for Ethanol Vapor – 1 mm Wall Thickness**

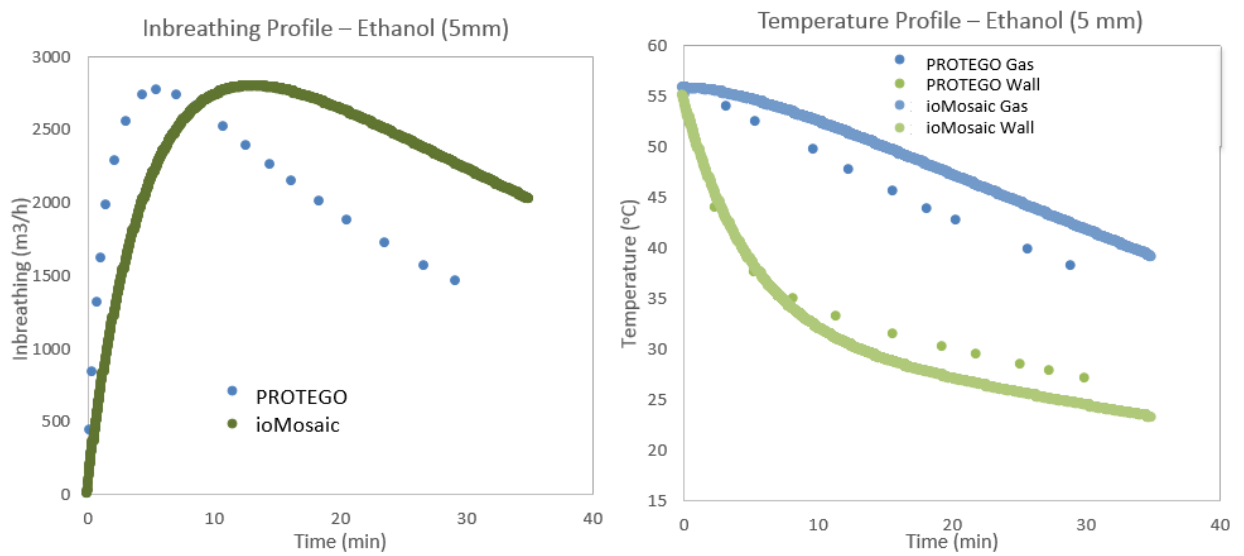

**Figure D.4: Inbreathing and Temperature Profile for Ethanol Vapor – 5 mm Wall Thickness**

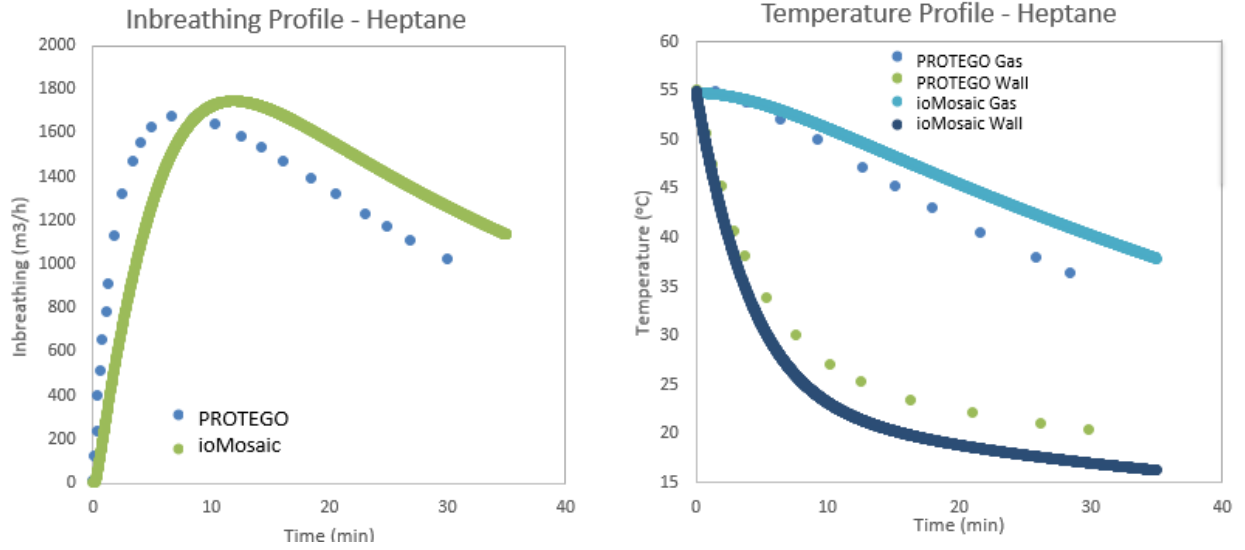

**Figure D.5: Inbreathing and Temperature Profile for Heptane Vapor – 1 mm and 5mm Wall Thickness**

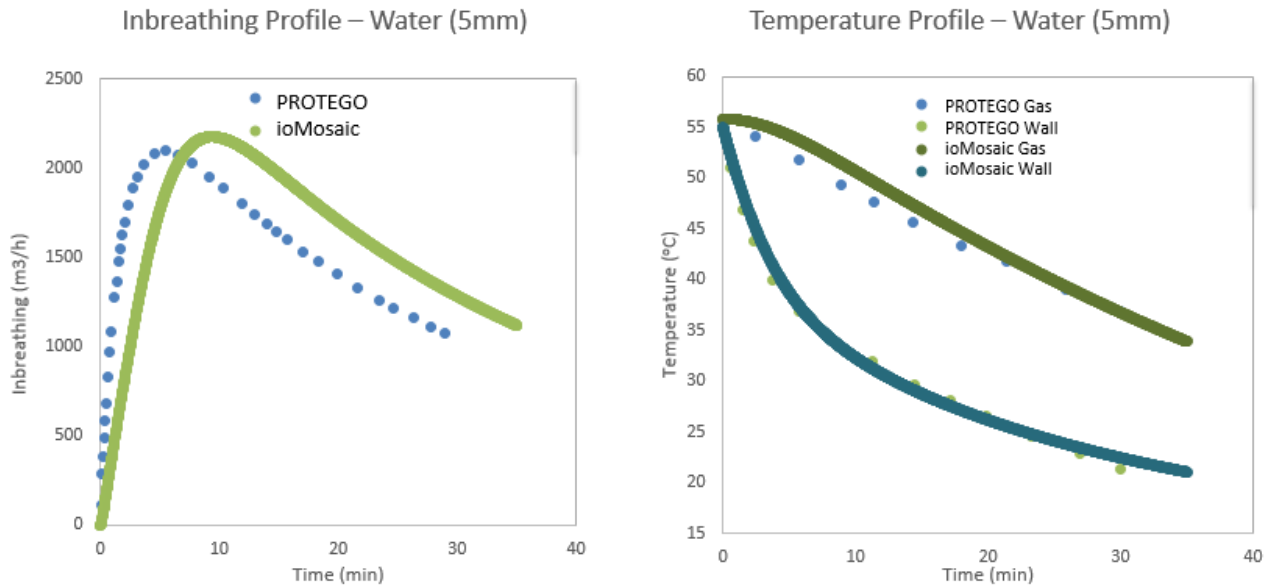

**Figure D.6: Inbreathing and Temperature Profile for Water Vapor – 5 mm Wall Thickness**

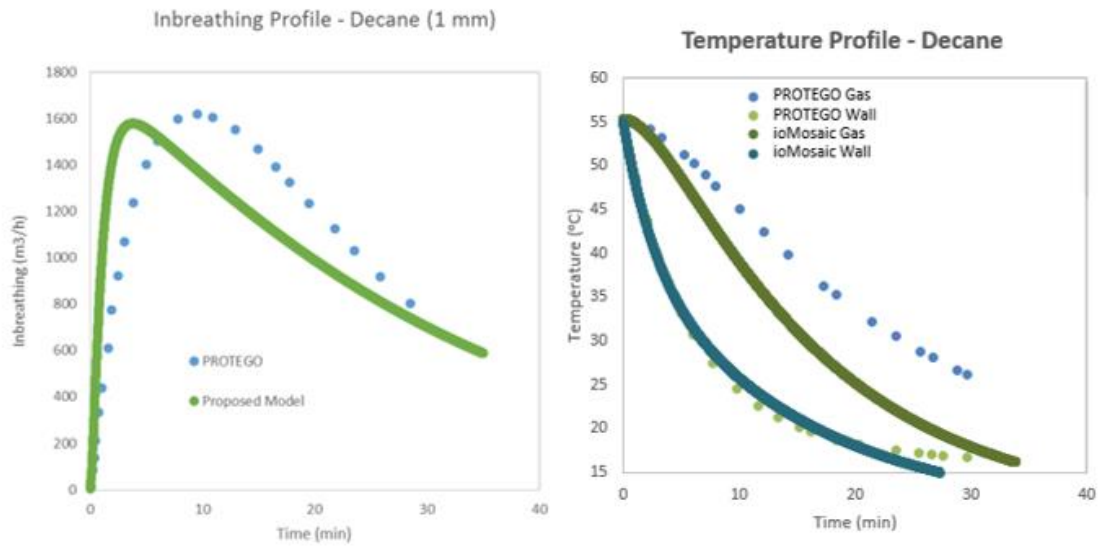

**Figure D.7: Inbreathing and Temperature Profile for Decane Vapor – 1 mm Wall Thickness**

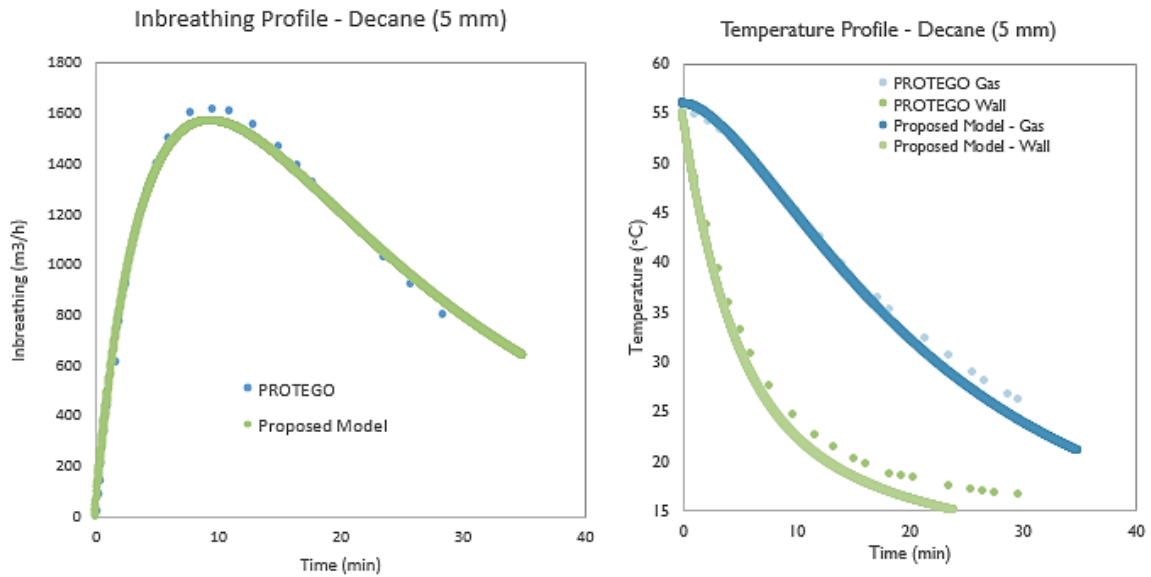

**Figure D.8: Inbreathing and Temperature Profile for Decane Vapor – 5 mm Wall Thickness**

## Appendix E

### Impact of Solar Flux on Thermal Inbreathing – Saudi Arabia



This sections illustrates the effect of different paints on the inbreathing and out-breathing in addition to the model results for the Saudi Arabia Location.

### **E.1. Impact of Paint Emissivity – Canada**

It can be seen in Figure E.1 below that using the black paint with the highest emissivity will result in the highest inbreathing and out-breathing rates.

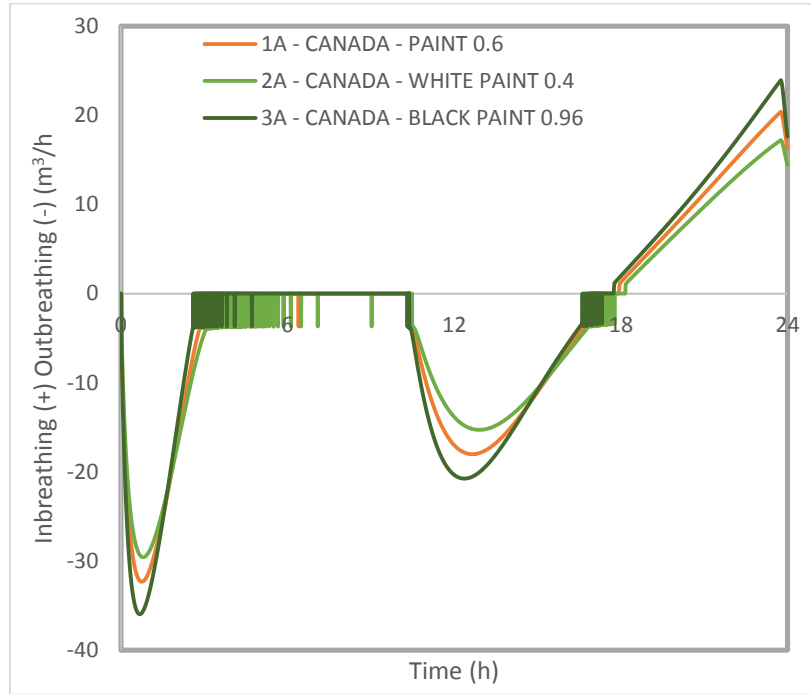

**Figure E.1: Impact of Different Paints (emissivity) on the Thermal Inbreathing and Out-breathing**

### **SuperChems Model for Jubail City, Saudi Arabia**

The average ambient temperature in Jubail City, KSA was set to 30°C. The maximum solar flux obtained from SuperChems for the coordinates (27.1° N, 49.37° E) was equal to 986 W/m<sup>2</sup>K at t = 12 h. The solar flux of Jubail City, Saudi Arabia as obtained from SuperChems Expert™ is given below in Figure E.2. The temperature, inbreathing, and out-breathing profile of the tank located in Saudi Arabia painted with aluminum bronze ( $\epsilon = 0.6$ ) is shown below in Figure E.3.

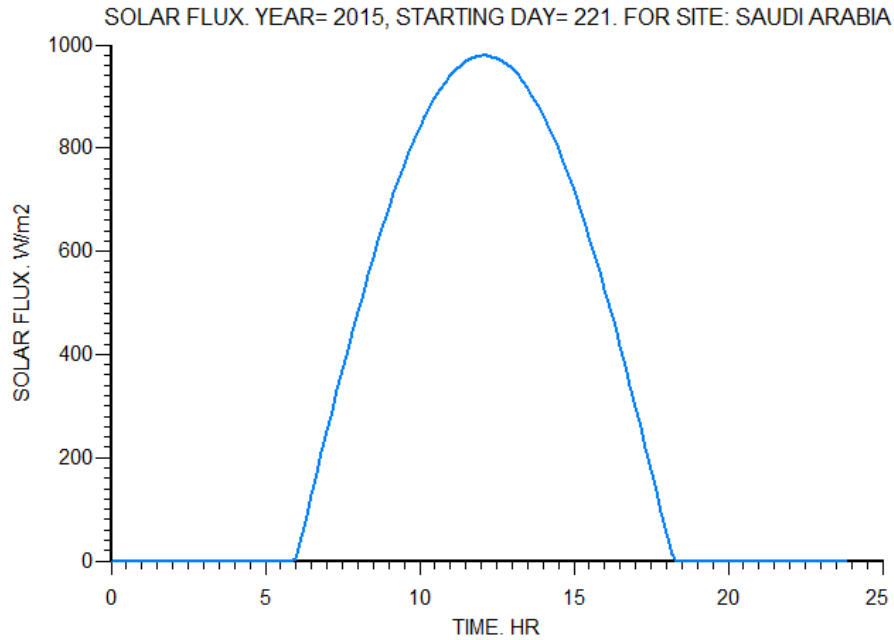

**Figure E.2: Solar Flux Distribution for Jubail City, Saudi Arabia (SuperChems)**

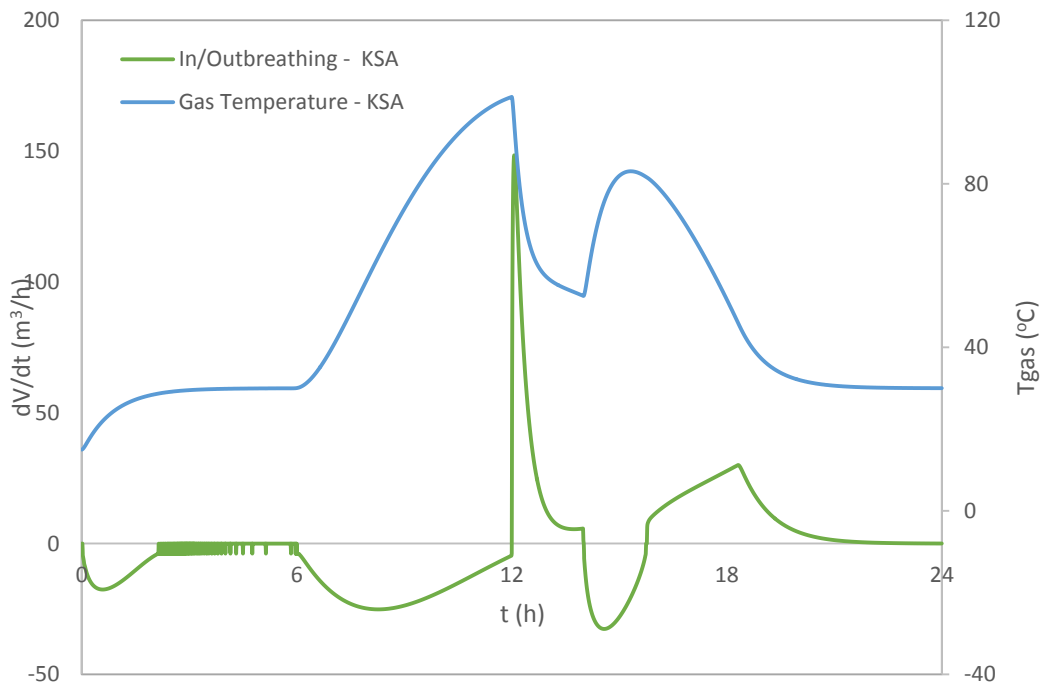

**Figure E.2: Gas Temperature and Inbreathing Profile for Aluminum Bronze Tank in Jubail City, Saudi Arabia**

The values of the maximum inbreathing, out-breathing and solar flux absorbed by the walls according to the type of paint (emissivity) is summarized in Table E.1.

**Table E.1: Maximum Inbreathing, Out-breathing, and Solar Heat Rate - Jubail City, Saudi Arabia**

<b>Paint (Emissivity <math>\epsilon</math>)</b>	$\dot{V}_{IT,max}$ Nm <sup>3</sup> /h	$\dot{V}_{OT,max}$ Nm <sup>3</sup> /h	$Q_{solar}$ kW
White (0.4)	128.6	29.8	5.8
Aluminum Bronze (0.6)	148.4	32.6	7.8
Black (0.96)	152.1	32.95	9.5

## **Appendix F**

### **Impact of different Water-Ethanol Blends on Thermal Inbreathing**

The mole fraction of ethanol in water was gradually increased to increase the volatility of the mixture. Four different blends were used for this purpose and are summarized in Table F.1 with the corresponding maximum thermal inbreathing of each. Figure F.1 illustrates the inbreathing profile for the different blends compared to pure water vapor. The gas heat transfer coefficient for this simulation was fixed,  $h_{\text{gas}} = 30 \text{ W/m}^2\text{K}$ .

**Table F.1: Maximum Thermal Inbreathing For Different Blends of Water-Ethanol Mixtures**

Blend	$V_{\text{max}}$ (m <sup>3</sup> /h)
100% H <sub>2</sub> O	12.0962
H <sub>2</sub> O + 40% EtOH	12.84804
H <sub>2</sub> O + 50% EtOH	12.71519
H <sub>2</sub> O + 70% EtOH	13.0332
H <sub>2</sub> O + 80% EtOH	13.083

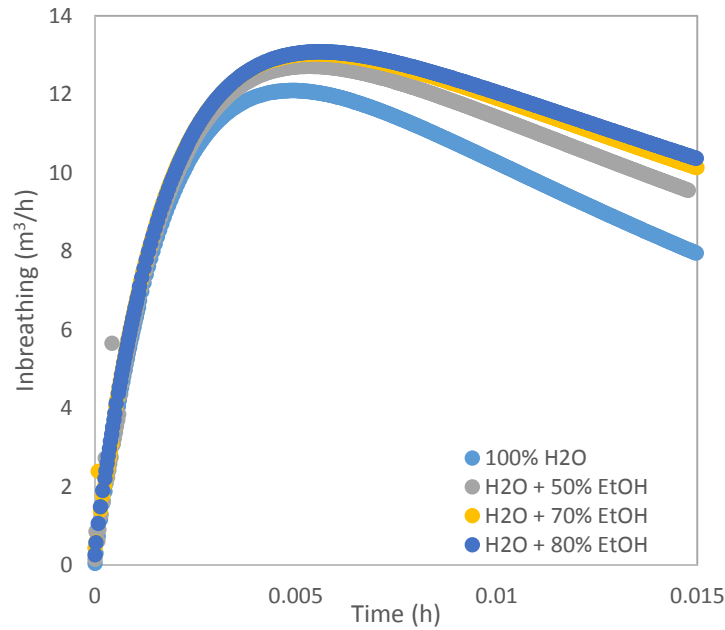

**Figure F.1: Inbreathing Profile for Different Blends of Water-Ethanol Mixture**

