

**Bangor University**

## **DOCTOR OF PHILOSOPHY**

### **Aspects of the biological and environmental processes affecting cockles in North Wales**

Newstead, Steven

*Award date:*  
2019

*Awarding institution:*  
Bangor University

[Link to publication](#)

#### **General rights**

Copyright and moral rights for the publications made accessible in the public portal are retained by the authors and/or other copyright owners and it is a condition of accessing publications that users recognise and abide by the legal requirements associated with these rights.

- Users may download and print one copy of any publication from the public portal for the purpose of private study or research.
- You may not further distribute the material or use it for any profit-making activity or commercial gain
- You may freely distribute the URL identifying the publication in the public portal ?

#### **Take down policy**

If you believe that this document breaches copyright please contact us providing details, and we will remove access to the work immediately and investigate your claim.

**Bangor University**

## **DOCTOR OF PHILOSOPHY**

### **Aspects of the biological and environmental processes affecting cockles in North Wales**

Newstead, Steven

*Award date:*  
2019

*Awarding institution:*  
Bangor University

[Link to publication](#)

#### **General rights**

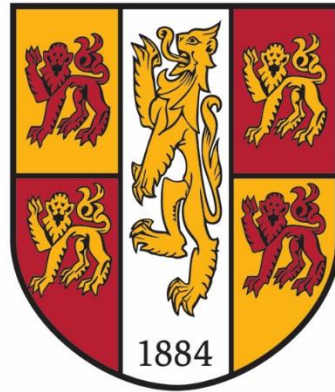
Copyright and moral rights for the publications made accessible in the public portal are retained by the authors and/or other copyright owners and it is a condition of accessing publications that users recognise and abide by the legal requirements associated with these rights.

- Users may download and print one copy of any publication from the public portal for the purpose of private study or research.
- You may not further distribute the material or use it for any profit-making activity or commercial gain
- You may freely distribute the URL identifying the publication in the public portal ?

#### **Take down policy**

If you believe that this document breaches copyright please contact us providing details, and we will remove access to the work immediately and investigate your claim.

# Aspects of the biological and environmental processes affecting cockles in North Wales



PRIFYSGOL  
**BANGOR**  
UNIVERSITY

A thesis presented to Bangor University for the degree of  
Doctor of Philosophy

Steven J. Newstead

April 2019

## Summary:

The edible cockle, *Cerastoderma edule* is an ecological and commercially important bivalve that occupies muddy and sandy tidal flats and estuaries in the temperate regions along the North East Atlantic coastlines and adjoining seas. By forming dense aggregations over large areas, *C. edule* supports a highly valuable shellfish fishing industry and is vital to the survival of other marine organisms that rely on its ecological functioning. This thesis has looked at the spatial and temporal variability of some of the biological and environmental processes that affect *C. edule* at different life stages. It has used two sites in North Wales, the Dee estuary and Traeth Melynog for providing samples for the experiments. Adult cockles collected in the spring 2015 were spawned in the laboratory. Their larvae were reared at three temperatures: 10, 15 and 20°C and fed 2 different food concentrations. After 21 days, larvae from Traeth Melynog were larger at 20°C than any other temperature and suffered less mortality compared to those from the Dee estuary. No effect of feed was observed between temperatures or site. Each fishery was assessed for the parasite and pathogen community of which *C. edule* are known to host. *C. edule* were collected between the autumn, 2014 to the end of summer, 2015 and divided into two separate halves. The first was processed for histopathology screening. Seventeen different parasite groups were identified across both sites, and six of these are known to cause significant harm at the individual or population level to *C. edule*. Overall, a difference in community structure was observed between the sites and the prevalence of the different groups was highly variable over the seasons. The second underwent biochemical analysis to measure the total energetic content using the Cellular Allocation Methodology (CEA). Cockles from Traeth Melynog were found to have more energy available to them but the energy consumed was the same between sites. High variability in the total lipid content and total carbohydrate content was observed across each season at both sites. Results from the three experiments are discussed in relation to the main objective of this thesis. The long-term management of cockle fisheries in North Wales and across the UK relies on the understanding of the complex processes that take place at all temporal and spatial scales.

## Acknowledgments:

Firstly, I would like to thank my supervisors at the School of Ocean Sciences, Dr Shelagh Malham and Dr Ian McCarthy. They have been so important in the progress of this thesis and their patience and understanding has been vital throughout. They have been incredibly supportive and believed in my ability to achieve this thesis.

I am grateful to Shelagh Malham for her expert knowledge on cockles and for keeping me on track when I was wavering. I am extremely grateful to Ian McCarthy for his optimism and his technical help on the biochemical analysis.

I would like to thank Prof. Chris Richardson for his input and advice in my supervisory committee meetings before his retirement, and for his belief in me over the last ten years since I have known him at the School of Ocean Sciences.

I would like to thank the Centre for Environment, Fisheries and Aquaculture Science who part funded this research. To Stuart Ross for his time spent processing my 800+ samples for histopathology screening. Your quality of work assisted in the identification of the parasites in these cockles.

I would like to thank my supervisor from CEFAS, Silvana Birchenough for her input and encouragement at the start of this PhD and for providing me with opportunity to come to CEFAS and work along-side the staff there.

I would also like to thank Mathew Longshaw for his time and for sharing his knowledge and expertise of parasites and pathogens found in *Cerastoderma edule*, and his feedback to early drafts.

To Nia Whitley and James Brown for their guidance in teaching me how to conduct the biochemical procedures. To Michael Thorpe for his laboratory assistance and endless weighing and homogenising of the samples.

For help collecting samples, I would like to thank Graham Monkman, Gillian Peacock and Richard Patton for being stuck in the mud with me in the Dee estuary.

I would also like to thank my two beautiful daughters; Amabel and Willow, for giving me a reason to complete this thesis and being part of the reason, it has taken so long.

Lastly, I would like to thank my wife Rebekah for her persistence, encouragement, support and endless love. Without your drive to succeed, we would never have moved to North Wales and been able to achieve everything we have together.

## Table of Contents:

<b><u>Chapter</u></b>	<b><u>Title</u></b>	<b><u>Pages</u></b>
Chapter 1	General Introduction	1 - 28
Chapter 2	An overview of the four largest cockle fisheries in England and Wales over the past 14 years	29 – 45
Chapter 3	Environmental unknowns in the growth and development of <i>Cerastoderma edule</i> (L.) larvae from North Wales	46 – 90
Chapter 4	Spatial and seasonal variation of the parasite and pathogen communities found in <i>Cerastoderma edule</i> (L.) from two cockle fisheries in North Wales, United Kingdom	91 - 148
Chapter 5	Spatial and seasonal variation in the Cellular Energy Allocation of <i>Cerastoderma edule</i> (L.) from two cockle fisheries in North Wales, United Kingdom	149 - 191
Chapter 6	General Discussion	192 - 209
Appendix		210 - 215

## General Introduction

### 1.1 Introduction to *Cerastoderma edule*

The common cockle or edible cockle, *Cerastoderma edule* (Linnaeus 1758; Phyla: Mollusca; Class: Bivalvia) is one of the UK's and Europe's most ecologically and economically important species of marine mollusc. They are found along coastlines between the upper intertidal and upper sub-tidal level, with their highest abundances found on extensive intertidal flats and in estuarine environments (Franklin 1972; Hayward & Ryland 1995; Dare et al., 2004; Cesar 2009). Globally *C. edule*'s distribution is concentrated to the shores of the north-eastern Atlantic and the adjoining seas (Malham et al., 2012). Its northern range extends into the Arctic Circle in the western Barents Sea at latitudes beyond 69°N. The southern extent reaches the coastal lagoons of Morocco between latitudes 34°N and 35°N (Gam et al., 2008; Genelt-Yanovski et al., 2010; Krakau et al., 2011) but pockets can be found amongst the seagrass beds and large tidal pools off the coast of Mauritania, south of the divide of populations derived from the last glacial period. Genetic analysis of the mitochondrial DNA has revealed that where the English Channel and North Sea meet, an area once separated by land, a heterogeneous population exists to the north and a homogenous population is found to the south of this divide. This separation does not affect at the species level but does suggest a more recent southerly expansion as some *C. edule* survived the extreme conditions of the glacial period by taking refuge in the North Sea (Krakau et al., 2011). *C. edule* share the same genus with the almost identical *C. glaucum*, or the lagoon cockle. Distinguishing between the two species when together is difficult but small details in their shell formation and ligament length separate the species (Boyden 1971). Habitats do not generally overlap as *C. glaucum* tends to prefer sheltered lagoons, as opposed to the exposed intertidal environments. Both species can inhabit the same environment (Boyden 1972; Brock 1979) and hybridisation has been successful in controlled laboratory experiments, but no evidence has been documented from natural populations. Possible timings of gamete release or geographical separation are controlling this, but more likely interspecific fertilization is less viable (Boyden 1971; Kingston 1973).

## 1.2 *Biology of Cerastoderma edule*

### 1.2.1 *Growth and Development*

Cockles can live for up to 6 years and reach a size of over 40 mm between the anterior and posterior ends of their shell (Tyler-Walters 2007). Their rate of growth in their first two years of life is far greater than any subsequent year and in this time they can reach up to 20 mm in size (shell length) (Seed & Brown 1977). Growth rate has been linked to many different factors including: temperature, immersion time, food availability, individual physiological processes, tidal level; density of cockles and site dynamics (Orton 1926; Kreger 1940; Hancock 1967; Richardson et al., 1979, 1980<sup>a,b</sup>; Guevara & Niell 1989; Jensen 1992, 1993; Rueda et al., 2005; Epelbaum et al., 2011; Pronker et al., 2013). Growth is an ongoing process as calcium carbonate, the material of which the shell is formed from (Rupert et al., 2004), is deposited daily, at a significantly higher rate during immersion by the tide (House and Farrow, 1968; Richardson et al., 1980<sup>a</sup>). As a result, tidal growth bands are observed in the shell which relate to the environmental conditions and can show seasonal changes experienced by the cockle during shell deposition (Richardson et al., 1979, 1980<sup>a,b</sup>). The height on the shore at which a cockle is found determine the time it spends immersed by the tide. Lower down the shore, cockles spend longer underwater and therefore benefit from more opportunity to feed leading to greater growth rates compared to cockles higher up the shore (Richardson et al., 1980<sup>a</sup>). Shell length has been positively correlated with immersion time. A study by de Montaudouin, (1996) in Arcachon bay, France, transplanted cockles between two intertidal sites to examine the effect of tidal level on. The author found that net growth started when cockles were immersed for 30% of the time and differences in cockle growth throughout the bay was a phenotypic response to their environment (de Montaudouin, 1996). Site based differences in growth across a wider area may not also replicate within site differences and the localised effects of shore height and immersion time. Along the Murmansk coast in the Barents Sea, growth rates and shell morphometry have been shown to be similar across 11 separate locations, over a 4-year period (Genelt-Yanovskiy et al., 2010).

Densities of cockles can also affect the rate at which individuals grow. They can be in excess of 1000 individuals per m<sup>2</sup> depending on their shell size and the time of year (Jensen, 1992, de Montaudouin and Bachelet, 1996; Eriksson et al., 2010). Densities can vary significantly within each cockle bed creating localised effects to growth rates. Jensen (1993) studies cockles at the same shore over different years. In 1984, cockles in densities of over 2000 individuals per m<sup>2</sup> obtained a mean shell length of 16.1 to 18.8 mm for two-year-old



cockles. By 1989, densities had reduced to less than 50 individuals per m<sup>2</sup> and the mean growth rate recorded was 26.5 to 30.3 mm for the same age class Jense (1993). This study also noted that the average tissue weight in 1984 was 48% lower in 1989. In high densities, intraspecific competition can play a huge role in the growth and condition of cockles as it can lead to competition for food causing starvation and tissue degradation (Jensen, 1993). Density dependant growth is particularly important to new recruits as these can have a large influence on numbers of biomass within a site (Franklin 1972; Richardson et al., 1993; Ferns et al., 2000; Ramon 2003; Dare et al., 2004; Howel et al., 2008). Densities of juvenile cockles, post settlement, can reach to 60,000 per m<sup>2</sup> (Jensen, 1992).

### 1.2.2 *Reproduction and Maturity*

*Cerastoderma edule* is a gonochoristic species that reproduces by synchronous broadcast spawning events which in the UK occur in the spring and summer months (Seed & Brown 1977; Hancock & Franklin 1972). Fertilisation of the released gametes takes place externally in the water column and the eggs go on to develop into planktonic free swimming larvae (Creek 1960; Ruppert et al. 2004). Maturity in cockles is reached at about 18 months after a period of rapid growth and in general cockles will be between 13mm – 16mm (Seed & Brown 1977; Dabouineau & Ponsero 2011). This will be dependent upon the conditions cockles have been exposed to and cockles that have survived their first and reach 12mm SL may be ready to spawn the following season (Cardoso et al. 2009). In aquaria conditions, cockles can reach the equivalent of 1 years natural growth in less than 100 days (Pronker et al. 2013), although this should be addressed with caution.

Gametogenesis or gonad development is the process in which reproductive organs undergo to become ready for reproduction. Singularly known as oogenesis in females and spermatogenesis in males the process has been classified in the literature by an arbitrary numerical scale which is used to describe the reproductive status of an individual or population. These scales range between 0-5 representing “spent” or “undifferentiated” stages (0) to fully “ripe” ready to spawn (5) dependent upon which sex is being described and which author is describing it (Seed 1969; Boyden 1971; Kingston 1974; Seed & Brown 1977; Steele & Mulcahy 1999; Cardoso et al. 2009). There is no definite classification system but the most simplified is described from Kingston (1974) who used stage 1 as the initiation of gametogenesis, stage 2 represented the development, stage 3 is used for ripe gametes that are

ready for release, stage 4 for when the gametes have been shed and stage 5 is when the gonads recovering from spawning. Over a 5 year study by Seed & Brown (1977), *C. edule* was shown to display significant patterns of the gonad stages. Gametogenesis generally begins in January or February and by April; most reproductively active cockles have reached their peak and are ready to spawn. Come September, most cockles have spawned and the gonads are in a spent condition or gametes which have not been released may be reabsorbed (Yankson 1986). It is evident by the varying stages of development in the cockles over the spawning periods and the presence of settlement of spat throughout the summer months indicates reproduction is not achieved by a single spawning event but by a polycyclic process (Boyden 1971; Seed and Brown, 1977; Newell and Bayne, 1980; Kingston 1984; Yankson, 1986). Similar patterns of reproduction in *C. edule* have been documented in other parts of their geographical range however small differences in the synchrony of male and female gametes have been found (Newell & Bayne 1980; Jensen 1992; Martinez-Castro & Vázquez 2012; Morgan et al. 2013). This may be a result of the spatial variability in environmental conditions that the cockle populations are exposed too and could possibly have an effect on the particular season's reproductive success ( Genelt-Yanovski et al. 2010; Morgan et al. 2013).

In the cockle *Fulvia mutica* (Reeve), a member of the Cardiidae which lives along coastline of china in the Yellow sea displays similar gametogenesis and spawning seasonal cycles as observed in *Cerastoderma edule* ( Hancock & Franklin 1972; Seed & Brown 1977). During late autumn and though the winter months the oocyte diameter for *F. mutica* gradually increased and reached its peak the following May when spawning occurred. The condition index (CI) displayed an opposite seasonal cycle with a decline in the CI during gametogenesis and the lowest levels during spawning and then an increase during the summer and autumn months. These patterns suggests cockles direct most of their energy in their reproductive strategy during the winter months which itself has been linked to water temperatures and food availability (Liu et al. 2008).

The onset of gametogenesis is linked with a reduction in temperature and there are suggestions that colder winters may benefit gonad development and result in greater settlement success the following season (Morgan et al. 2013). Honkoop et al. (2008) were able to show that egg size was affected by temperature. Larger egg diameters were recorded at colder temperatures over a two-year study. The cause behind the temperature influence was linked to the relative short period of time gametogenesis takes place for *C. edule*. Yankson (1986) found gonad condition followed different patterns over two years and that a severe winter increased

spatfall the following year. *C. edule* sampled in 1981 showed a “normal” gonad CI, whereas those sampled in 1982 after the cold winter continued to spawn through the season and the gonad CI was considered “abnormal”. Care must be taken to assume that the winter was the sole factor controlling the increased spatfall observed in 1982 as the authors do not record any temperature differences between 1981/82 spawning periods and suggest that lower predation and improved feeding conditions may have boosted settlement success. Cockles from the Barents Sea area able to spawn and reproduce in lower temperatures to those from inhabiting a warmer temperate environment. Genelt-Yanovskiy et al. (2010) recorded water temperatures over a 7-year period and found that during the warmer months of the year, temperatures failed to get past 9°C. Recruitment to the population may be affected by extreme conditions as 1 to 3-year-old cockles were absent during 2005 sampling. This may suggest a lack of recruitment in previous years but may also be due to the time and location of the sampling. Strasser et al. (2001<sup>b</sup>) suggests that post-settlement processes are inherently responsible for establishing the community composition of the intertidal habitat and that the time of peak spawning and settlement periods may vary on a yearly basis depending upon the previous winter conditions.

Synchronous spawning events improve fertilisation success as eggs are quickly fertilised by sperm after they are released from the adults. This method relies heavily on the proximity of both the male and female cockles. Andre & Lindegarth (1995) modelled the dilution effect of sperm on fertilisation success and found that concentrations of 1000 – 10,000 sperm per  $\mu\text{l}^{-1}$  achieved a high fertilisation rate and that 50% fertilisation success can be achieved with an egg to sperm ratio of 1:1500. They also found that between 4 to 8 hours post release the eggs and sperm would become infertile and that sperm concentrations varied depending upon current velocity and distance between spawning cockles as sperm was quickly diluted. Ultimately sperm concentration is driving fertilization but the overall success is influenced by current velocity and direction, the proximity to other spawning cockles and by the length of time male cockles release sperm into the water column (Andre & Lindegarth 1995). Intertidal barnacles are known to synchronise their spawning events with high turbidity concentrations in the water column as this decreases the total cannibalism effect on spawned larvae by the adult barnacles (Gyory et al. 2013). Using environmental cues for spawning activity will provide optimal conditions for larval survival and also limit predation pressure. *Cerastoderma edule* may have evolved a similar strategy by using the temperature to ripen their gametes and then to synchronise their spawning with the onset of the spring phytoplankton

blooms, spring tides or harsher weather periods when natural turbidity levels would be higher thus promoting greater larval survival ( Liu et al. 2008; Gyory et al. 2013).

### 1.2.3 Larval Phase

The embryonic and larval stages for *Cerastoderma edule* has been extensively described by Creek (1960). Newly released eggs are between 50 – 70µm in diameter and will quickly develop a thick buoyant gelatinous membrane covering that assists with dispersal and fertilisation, prevents polyspermy and provides some form of protection (Pechenik 1979; Pronker et al. 2013). Once fertilised, the eggs will go through meiotic division of two unequal cells and polar bodies are formed indicating success (Creek 1960; Helm & Bourne 2004). Cell division begins soon after and it takes approximately 24 hours for gastrulation to be completed. Within 48 hours, cilia have developed and a motile trochophore around 80µm has been formed. Over the next couple of days, the trochophore larva will develop its typical lamellibranch shell and velum and be in the veliger stage where it can open and close the shell and retract and protrude the velum for locomotion. The veliger's are also known as “D” larvae and have a SL of ca. 110µm (Creek 1960; Pronker et al. 2013).

The planktonic larval stage for *Cerastoderma edule* lasts for approximately three and a half weeks after which the larvae will begin to metamorphose and settle in the sediment (Creek 1960). This length of time can vary dependent upon the temperature larvae are subjected. During metamorphosis the velum, the larva's propulsion and feeding mechanism is lost and the juvenile cockle (or spat) will develop gills, a foot and eyespots (Pronker et al. 2013). Creek (1960) reared larva in the laboratory at temperatures between 10 – 15°C and found settling and metamorphoses occurred when they reached 270µm shell length (SL), the greatest distance measured between the anterior and posterior edges of the shell (Orton 1926). This is similar to findings by (Kingston 1974) when it took between 26 – 30 days at 15°C for settlement followed by metamorphoses. SL measured between 270 – 320µm. This study reared larvae in different temperatures and found a reduction in growth and behaviour at 10°C with an average SL of 200µm after 39 days. At 20°C and 25°C the larval stage took 20-24 days to complete and grew to over 300µm SL whereas at 30°C growth was not as consistent, and most had died prior to metamorphosis. Those reared at 35°C were all dead within 4 days of the experiment (Kingston, 1974). Faster development has been noted by Jonsson et al. (1991) who describes it taking between 17 – 21 days at 15°C to reach 280µm for larvae to have developed

a foot and were ready to settle. Difference in methods between these studies does not highlight anything significant which could influence the growth of the larvae. More recently Pronker et al. (2013) recorded metamorphosis at day 9 after initial fertilisation of  $226 (\pm 22.1)\mu\text{m SL}$ . The larvae were reared at  $19^{\circ}\text{C}$  and fed a mixture diet of the flagellates *Isochrysis galbana* and *Pavlova lutherii* and the diatom *Chaetoceros muelleri*. All other studies used just *I. galbana* as a singular feed which may have contributed in the difference seen between the studies. Methods used in bivalve cultivation recommend a mixture of diets to provide the larvae with their optimal nutritional needs, therefore supporting the study by Pronker et al. (2013) (Bayne 1965; Utting & Millican 1997; Helm & Bourne 2004; Galley et al. 2010; Aranda-Burgos et al. 2014). Unfortunately, no studies have been able to manipulate these experiments in their natural habitat and record data on *C. edule* larval stages based on either temperatures or the food they are exposed to. Natural spatfall of juvenile cockles can happen over a large window during the spawning season. Depending on location, this could be between April and September (Lebour 1938; Baggerman 1953; Seed & Brown 1977; Wehrmann 1999). It is difficult to pinpoint when spat sampled in sediments have been fertilised and therefore predict the duration taken to metamorphose and settle. Studies which successfully achieve cockle larvae generally terminate after a maximum of 30 days with the exception of Pronker et al. (2013). Reasons for this are not explained fully but it is likely that survival of the larvae is the limiting factor or that the transition requires different laboratory approaches which have limited the studies. Linking the pelagic and settlement phases together in further research will give a better understanding in the factors controlling this vital stage of *C. edule*'s life. Pronker et al. (2013) successfully describes the larvae beyond the settlement stage and has achieved fertilisation from second generation cockles, however this study focusses on the possibility of *C. edule* as an aquaculture species and not on its natural ecology. Larval growth has been studied using salinity as a variable due to their natural exposure a range of concentrations. Larvae were reared at  $17^{\circ}\text{C}$  in twelve different salinity replicates by Kingston (1974). They found concentrations of 30 – 35‰ promoted optimal growth rates although *C. edule* tolerated a large range of concentrations without affecting mortality. This is limited however as at 20‰ deformities were frequently observed and those subjected to 45‰ grew slower and failed to metamorphose.

#### 1.2.4 Settlement phase

Dispersal of larvae is location dependant. Important areas such as the Wash, the UK 's largest estuarine system is hydrodynamically complex. Water flows out of the embayment through complex channels and tidal flats along its eastern and western banks, whilst the inflow of water comes through the central passage. The system as a whole acts as a sediment trap with net sediment transport towards the main land (Ke et al. 1996). Pelagic larvae released in this area may fail or find it extremely difficult to escape the catchment which could have implications on population health due to self-recruitment supporting stock numbers (Sponaugle et al. 2002; Coscia et al. 2012). Entrapment and self-recruitment is not restricted to the Wash. Coscia et al. (2012) modelled larval dispersal of *C. edule* in the southern Irish Sea. Using genetic analysis, they found the Burry Inlet stocks to be an isolated population. This tidal area displays similar characteristics to those found at the Wash. Cockles collected from open coastal environments displayed connectivity between stocks as no significant generic differences between Irish and Welsh cockles were found indicating a passive larval dispersal range across the southern Irish Sea (Coscia et al. 2012).

Once the pelagic phase is complete, larvae will settle and live a sedentary life. During this transitional period the larvae are between 250 - 300 $\mu$ m SL (Creek 1960; Kingston 1974; Jonsson et al. 1991; Pronker et al. 2013). Settlement may happen in areas of muddy sediment, further up the shore line where the height of the sediment can be up to two inches higher than the average level of the cockle bed (Kreger 1940). Burrowing into courser sediments may be difficult for the juvenile spat therefore leaving them more vulnerable to predation (Veer et al. 1998). Pressure from mobile predators will also be increased if settlement occurs lower down the shore as emersion times will be longer.

Density of adult cockles plays an imperative role in the settlement of juveniles. High densities of adults impact the macrozoobenthic community and place pressure on settling bivalve and polychaete larvae (Flach 1996). Sediment disturbance and larviphagy by the adults make it difficult for spat to reach the sediment and settle. Andre & Rosenberg (1991) found a negative correlation between adult density and juvenile recruitment from the Swedish coast. Larviphagy from bivalves is a major factor effecting cockle beds and could influence the balance of the ecosystem. Laboratory based experiments on larvae ingestion rates by the three main bivalve species in the Oosterschelde estuary, Netherlands, showed that *Mytilus edulis*

larvae are ingested at the same rate as the surrounding phytoplankton by adult mussels, cockles and oysters whereas larvae from *Crassostrea gigas* seem able to divert this form of predation pressure as consumption was 50% less (Troost et al. 2008<sup>a</sup>). Although neither species of larvae are able to escape the inhalant flow when in close proximity to the adults, *C. gigas* is able to swim faster than *M. edulis* therefore being able to migrate away from the adults and take advantage of water away from feeding adults (Troost et al. 2008<sup>b</sup>). Huxham & Richards (2003) suggests recruitment is determined by hydrodynamic factors and not sediment type and flume experiments by Jonsson et al. (1991) supports water flow is a component the settlement phase. In still water *Cerastoderma edule* larvae intermittently swim vertical in the water, stop and sink, then rest on the bottom for a few seconds. Introducing low water flow creates passive drifting above the seabed. As flow is increased eddies form above the sea bed with re-suspension of settled larvae occurring in high velocities, trapping them within the benthic boundary layer (Jonsson et al. 1991). This form of transportation may allow larvae to select suitable habitats but this is difficult to determine as tidal flow over intertidal mud flats will exceed the larval swimming limits rendering them at the mercy of the currents (Jonsson et al. 1991). Annual variations in wind conditions and direction are linked with recruitment success. Based on modelled data, retention of cockle larvae in the Wash embayment was high with a constant northerly wind and settlement success was best when easterly winds prevailed (Young et al. 1998). Spawning site was important and contributed to retention and settlement success. Sites closer to the northern opening showed less retention and all sites within the area had different physical characteristics and played varying roles in the systems recruitment dynamics. Importantly tidal cycles and timing of release of the larvae had a great effect on settlement success as the amount of neap and spring tides in the larva's pelagic phase influenced success. Young et al. (1998) larva developing within 21 days and exposed to more neap tides displayed greater settlement compared to larva taking 28 days. Larva settling during spring tides will have larger areas of suitable habitat available to settle on therefore promoting recruitment. Secondary settlement has been observed by *C. edule* as a result of hydrodynamic forces lifting juveniles off the seabed that have unsuccessfully anchor themselves to the sediment (Montaudouin et al. 2003). At Treath Melynog in Wales settlement begins at the low shore and as the juvenile spat grow, they migrate up to the high shore supporting the observations by Montaudouin et al. (2003) (Whitton, 2013). Settlement tends to be gregarious as densities can exceed thousands per m<sup>2</sup> (Ramon, 2003) as previously described. It is unclear if habitat selection controls settlement and the densities observed or if there are any biological or chemical cues triggering the process to specific areas. It's also unknown if settlement begins

with one individual and others follow or what initiates metamorphoses. Montaudouin et al. (2003) managed to achieve an 87% settlement rate when juveniles were introduced to medium sand supporting the capability of habitat selection, but this was a controlled laboratory experiment and not a field observation. Oysters have been subjected to many studies focusing on environmental factors and chemical compounds as cues for settlement (Grant et al. 2013; Mesías-gansbillier et al. 2013). *Ostrea edulis*, the European flat oyster responded well to increased hormone levels in the water and showed a maximum settlement rate 4 times higher than the control group (Mesías-gansbillier et al. 2013).

### 1.2.5 Burrowing

*Cerastoderma edule* is a soft sediment burrowing species and is generally found in sediments consisting of coarse-sand to muddy-sand, with a preference of a mean grain size between 62.5 – 150  $\mu\text{m}$  (Compton et al., 2009). They are generally associated with sheltered coastal intertidal areas. Cockles use their muscular foot to dig themselves into the sediment to depths of up to 10 cm (Tyler-Walters 2007; Dabouineau & Ponsoero 2011), but are usually found in the top 5 cm (Callaway et al., 2013). Burrowing depth is related to temperature and cockles will burrow deeper during the winter months to protect themselves from the cold (Murray and Tarrant, 2015). Burrowing into the sediment, provides substantial protection from predation (by crabs), especially at periods of low tide (by birds) and from the physical mechanics of living in a highly dynamic environment (Sutherland & Sutherland 1982<sup>a</sup>, 1982<sup>b</sup>; Jensen & Jensen 1985). By anchoring themselves to the seabed, it limits potential dislodgment from the seabed and unwanted transportation by currents and waves (Ansell et al., 1981). Their foot enables them to crawl or shuffle across the sediment and is possibly used for detecting suitable habitat for burrowing (Richardson et al., 1993). Burrowing into the sediment creates disturbance which in-turn increases the sediment-water interface that facilitates erosion and re-suspension of particles and organic material. A positive relationship between the presence of cockles and sediment stability can be seen on cockle beds. When found in high densities *C. edule* acts as a sediment-stabilizer and can control the hydrodynamics of the area in which they are found (Fig. 1) (Eriksson et al., 2010). Sediment banks can form as water flow decreases over dense patches of cockles and finer particles and organic material are able to settle out of suspension. Through pseudofecal production, which is the unwanted particles expelled through their syphon's during feeding and water exchange, helps in binding this sediment and organic



material together due to the cohesive mucus it contains (Haven 1966; Nowell et al., 1981). Both processes have direct benefits to the cockles as they promote recruitment of future generations by creating suitable habitat for the settlement of spat (Eriksson et al., 2010; Whitton et al., 2013; Donadi et al., 2014). If bed shear stress and sediment suspension concentrations increase, cockle behaviour changes and a reduction in burrowing activity can be observed. Pseudofecal production and sediment stability may be halted (Ciutat et al., 2007). The sediment balance can depend heavily on the presence of cockles and their removal could hinder other co-habiting species (Reise 1985; Ferns et al., 2000; Ciutat et al., 2007). Burrowing ability of cockles has also been negatively linked to infections of digenea parasites belonging to the genus *Bucephalus*, *Himasthla* and *Monorchis* (Jonsson and André, 1992; Desclaux et al., 2002; Thieltges, 2006; Longshaw and Malham, 2013). Infection can lead to damage of internal tissues, especially the foot and lead to the decreased ability to burrow successfully back into the sediment during periods of low tide, ultimately leaving them exposed and susceptible to predation

### **1.2.6 Feeding**

Cockles are members of the lamellibranch's whose characteristics include a unique "W" shaped filamentous gill which is used for both gas exchange and for filter feeding. Thousands of microscopic cilia attached to the gill surface pump water down through the inhalant syphon, passing it along the gill where particulate matter is filtered out from the water, and then back out the exhalent syphon. Cockles are opportunistic suspension feeding organisms which filter and digest a variety of suspended particles such as phytoplankton, zooplankton, detritus, bacteria and dissolved organic material from the water column (Rueda and Smaal, 2002; Gosling, 2003; Cesar, 2009; Elliott et al., 2012). As juveniles, they also feed upon the microphytobenthos, consisting of unicellular eukaryotic algae and cyanobacteria that grow in the upper layers of the sediment (MacIntyre et al., 1996). Cilia on the gills transport the filtered material along to the posterior end of the labial palp where ciliated ridges and grooves sort the particles based on whether it is mineral or organic. (Ruppert et al., 2004). Mucus secreted from the labial palps binds the suspended food particles together where it is transported to the mouth for ingestion. Material not suitable for ingestion is discard as pseudofeces (Ruppert et al., 2004). Cockles can adapt feeding behaviour, including filtration rate and pseudofecal production to suit conditions. Inglesias et al. (1992), was able to demonstrate that when cockles are fed organically rich diets, they were able to increase ingestion by maintaining a steady

filtration rate, whilst adjusting the clearance rate of pseudofeces. When fed low organic diets, for example high mineral content, clearance rates were maintained, and ingestion of particles regulated. The greatest energetic benefit to the cockles was associated with preingestive food selection (Inglesias et al., 1992). To assist digestion, in particular carbohydrates, cockles have a biphasic digestive process. Within the stomach, a style sac secretes enzyme which form a crystalline style (Ruppert et al., 2004). Made of glycoprotein, the crystalline style is rotated by cilia. It dissolves and releases enzymes providing extracellular digestion of the food particles prior to reaching the digestive gland where intracellular digestion takes place (Ibarrola et al., 1998; Ruppert et al., 2004).

### **1.3 Ecological Importance**

#### **1.3.1 Predation**

*Cerastoderma edule* provides an important and wide-ranging ecosystem services (Fig. 1). As a member of the benthic community they can be a key contributor to or determine a range of ecological functions. For example, directly, they are an important link in food webs dynamics and indirectly, assist in the recycling of nutrients and minerals (Fig. 1) (Cesar, 2009). By consuming primary producers such as the phytoplankton, they mediate a link between the pelagic and intertidal ecosystems, whilst also being targeted as prey items by larger macrofauna species (Genelt-Yanovskiy et al., 2010; Burdon et al., 2014;).

Overwintering bird populations in northern Europe rely heavily on intertidal organisms for sustenance, with many bird species predate on cockles when they are at their most vulnerable during the low tide (Norris et al., 1998; Malham et al., 2012). A healthy cockle bed has the potential to control the fine balance of an ecosystem and the connectivity between different trophic levels. Excessive removal of cockles from mud flats through commercial harvesting, can have knock-on effects to other species which rely on the cockles as food. In the Wadden Sea, off the coast of northern Europe, commercial shellfish fisheries had a role in the mass mortality of *Somateria mollissima*, the common eider. During the winter of 1999/2000, intensive fishing effort reduced the total shellfish resource (including *Mytilus edulis*) suitable as prey to foraging birds to only 8.5% in areas where it is most accessible for foraging (Camphuysen et al. 2002). Coupled with the inter-specific competition between other wading bird species, the common eider was forced to contract its foraging area and take refuge by shifting its feeding to *Spisula subtruncata*, which itself had seen an 85% reduction in numbers

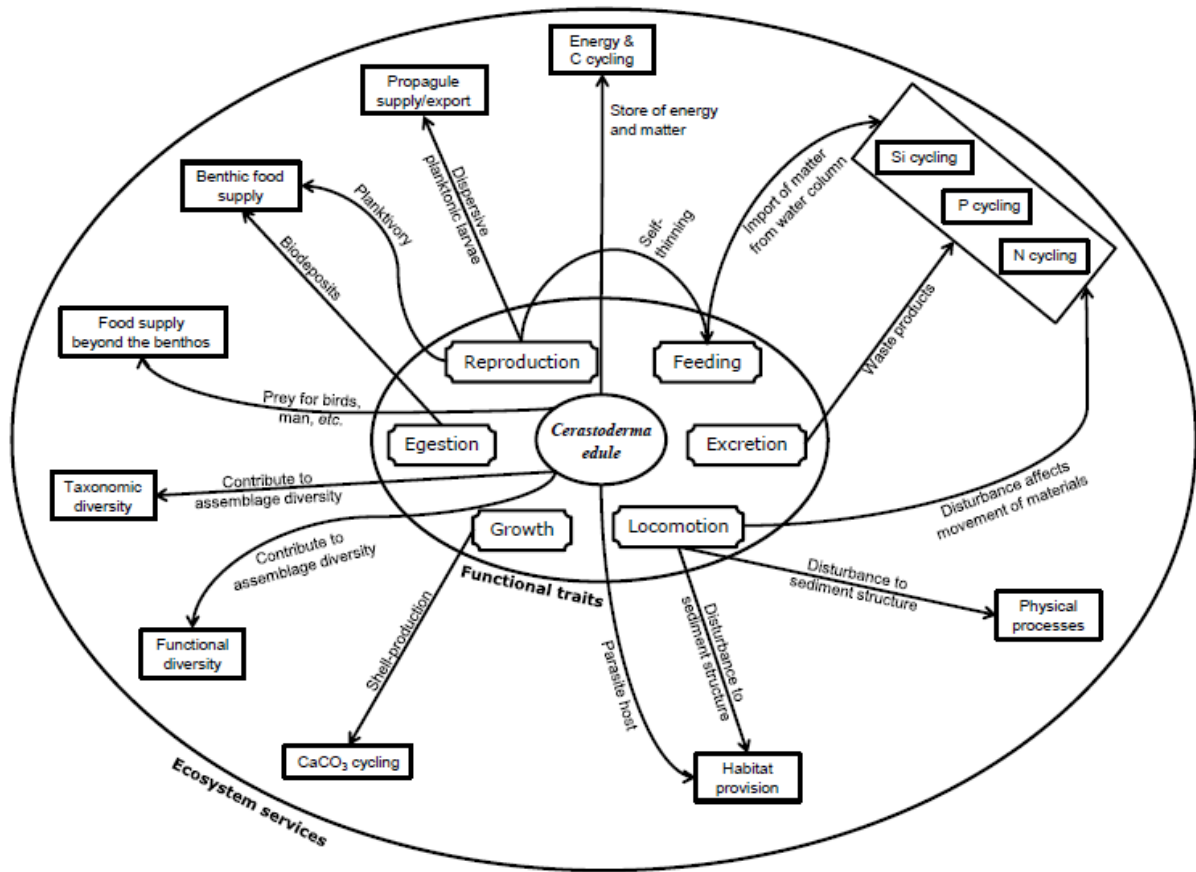
in the areas which are fishable to the birds. As a consequence, there was a significant crash to the population of the common eider (Camphuysen et al. 2002). The oystercatcher, *Haematopus ostralegus*, is another wading bird that feeds heavily on *Cerastoderma edule* during the winter (Goss-Custard et al., 2004; West et al., 2007) and the Burry Inlet in South Wales, provides a winter refuge for this species (Norris et al., 1998). Oystercatcher abundance observed in the spring in the Burry Inlet has been shown to be positively correlated to high cockle biomass at the beginning of the previous winter (Norris et al., 1998). However, if during the winter the biomass of cockles is depleted by predation from birds and through fishing pressure, then there can be a negative relationship between cockle biomass and the abundance of oystercatchers seen in the spring. This is particularly noticeable when cockle biomass in the winter starts off low and the combined effects of predation and fishing will cause the oystercatcher to disperse away from the area due to low food availability (Norris et al., 1998). Oystercatchers will also switch from feeding on larger cockles (>15mm) to smaller cockles (<15mm) when the number of cockles over winter reduces within a bed (O'Conner and Brown, 1977).

Introducing marine protected areas (MPA's) into shellfish fisheries provides benefits to the species richness and community complexity (Russ and Alcala, 2011). MPA's also remove the negative effects associated with fishing to the protected area and essentially create safe zones for the species living in them. Evidence suggests that "overspill", the net export of larvae and juveniles from MPA's to surrounding non-protected areas, can occur for species that have a limited range throughout their whole life, i.e. short larval dispersal and low adult mobility (Sweeting and Polunin, 2005). As such, the level of overspill is largely dependent on the biomass of the species within the MPA's, but for shellfish such as the cockle, it will unlikely be enough to compensate for the direct loss from fishing (Sweeting and Polunin, 2005). The creation of MPA's in the Wadden Sea in 1993 was designed to protect the decline of shellfish eating birds by creating areas that are off limits to fishing, thus allowing the habitat and cockles to recover after years of fishing pressure (Verhulst et al., 2004). Verhulst et al. (2004) showed that the whilst the MPA's met their objective by supporting higher numbers of cockles, unfortunately, oystercatchers were not been able to adapt their feeding strategy to benefit from the new spatial heterogeneity of their food supply. Oystercatchers feeding inside the MPA's were found to have high levels of shellfish in their diet and were in better condition compared to birds feeding outside the protected areas. Mortality was also lower for oystercatchers feeding inside MPA's (Verhulst et al., 2004). Therefore, introducing MPA's does not necessarily protect shellfish eating birds if there is continued fishing pressure on the stock. Furthermore,

competition between the two for the same stock, reduces the total amount of cockles available to both birds and fishermen, forcing the birds to forage on other species (Verhulst et al., 2004). Fortunately, like the common eider, oystercatchers can adapt their prey items and resist crashes in cockle populations. After the severe winter of 1962/63, birds from the sand flats in Morecambe Bay, UK, switched their diet to *Macoma balthica* as cockle numbers depleted (Dare & Mercer 1973). This adaptation suggests that although cockles may be the preferred choice in areas where high densities occur, if other foods are available and there is limited fishing pressure to the bed, then the impact to bird populations can be ameliorated.

Mobile epibenthic predators such as the shore crab *Carcinus maenas*, and the brown shrimp *Crangon crangon*, are important predators of *C. edule*. Jensen & Jensen (1985) found that in the Wadden Sea, *C. maenas* might have the ability to control bed recruitment by predated upon recently settled spat. Conversely, Veer et al., (1998) showed that even though *C. maenas* and *C. crangon* predated on the spat, it was likely that *C. crangon* was the mortalities observed in this study. Despite this, predation did not have a significant effect on recruitment due to the high numbers of settlers. *C. maenas* may have more influence on larger cockles as it is able to predate on a larger size ranges, reducing the numbers of juvenile cockles and creating a cascading effect in population structure (Flach 1996; Malham et al., 2012).

When the cockle beds are submerged fish such as plaice, *Pleuronectes platessa* and flounder *Platichthys flesus*, migrate into shore and will feed upon *C. edule*. These species crop the siphons off the cockles as they are extended out of the sediment whilst feeding and predate on spat and juvenile cockles that are small enough to ingest whole (De Vlas 1979; Le Mao 1986). Along the Swedish coast in two shallow water habitats during 1977 and 1978 the collective predation pressure from *P. platessa*, *C. maenas* and *C. crangon* consumed up to 92% of the total *C. edule* production (Pihl, 1985).



**Figure 1.** Conceptual model of how *Cerastoderma edule* affect ecosystem goods and services within the marine benthic environment (Source: Cesar, 2009).

### 1.3.2 Environmental tolerances

A burrowing in-faunal species, *Cerastoderma edule* is able to survive in highly fluctuant environmental conditions. Aerial exposure in intertidal environments is a daily occurrence and in general cockles taking residence higher up the shoreline will experience longer periods exposed. In the Wadden Sea off the coast of the Netherlands, Ramon (2003) showed that cockles found in high densities at one of their sampling stations towards the high water line spent only 56% of the time submersed. In air temperatures of 10°C, *C. edule* is able to survive for up to 14 days when exposed although this duration is reduced as temperature is increased. This is made possible by the uptake of oxygen by diffusion into the mantle cavity as they gape (Boyden 1972). Temperatures with the rise and fall of the tide therefore cockles are accustomed to these changing environments. Lethal maximum and minimum mean temperatures for *C. edule* has been shown to be between 0.34°C (lower limit) and 32.19°C (upper limit) for individuals taken from the Wadden Sea (Compton et al. 2007). They can survive comfortably in temperatures ranging from 3 to 25°C with 10°C being their optimal

temperature (Reise 2003). In the Barents Sea, water temperatures can be less than 3 °C for long periods of time during the colder months of the year although they are found in lower densities compared to those inhabiting the more median parts of their geographic range (Genelt-Yanovskiy et al. 2010). Salinity tolerances for adult *C. edule* vary will also vary and to some extent; distribution is limited by salinity concentrations (Brock 1979). The ideal salinity range is between 10 to 35 *psu* (Reise 2003). Hyper-saline conditions are experienced in the lagoons of Mauritania of concentrations up to 42 *psu* showing that this species can withstand periods of stress and continue to survive (Wolff et al. 1993).

### 1.3.3 Mortality

*Cerastoderma edule*'s ability to withstand extreme environmental conditions beyond their comfortable limits has been linked to mass mortality events and the overall health of some cockle populations (Malham et al. 2012; Burdon et al. 2014). High temperatures increase the threat of desiccation during aerial exposure and can also result to ecosystem eutrophication caused by nutrient overloading and the depletion of oxygen. Studies have struggled to find a direct link with high temperatures and mortality as there is usually other factors involved (Burdon et al. 2014). Parasite and pathogen loading, pollution, stocking density, predation, larval settlement success, oxygen levels and food availability should be considered if trying to pinpoint the causal mechanisms involved in mass mortality events (Sutherland & Sutherland 1982<sup>a</sup>; Jensen & Jensen 1985; Desprez et al. 1992; Thieltges 2006; Longshaw & Malham 2012; Callaway et al. 2013; Burdon et al. 2014). Extreme low temperatures during the winter months can have a direct link to mortality with Hancock & Urquhart (1964) finding the severity of the 1962/63 winter drastically reduced the cockle population in the Burry Inlet in South Wales, UK. Similar mortality events have been well documented from the Wadden Sea with their effect seen in the recruitment the following years. Strasser et al. (2001<sup>a</sup>) found that density of live cockles reduced from 15 per m<sup>2</sup> towards the end of 1995 to 3 per m<sup>2</sup> by October 1996. This had a knock on effect with recruitment as subsequent milder winters produced greater recruitment early on in the season although the long term survival of the recruits was less than after the 1995/6 server winter (Strasser et al. 2001<sup>b</sup>). During the 1995/6 winter ice flows were observed scouring the tidal flat and were a factor for the decline in the mussel *Mytilus edulis* but these and the winter itself could not be singled out as the only factor controlling *Cerastoderma edule*'s demise (Strasser et al. 2001<sup>b</sup>). It is plausible that frozen sediment contributed to the cockle's mortality as observed by Kristensen (1957) who reported that the

winter of 1946/47 wiped out the entire cockle population of the Dutch Wadden Sea due to the sediment freezing down to burrowing depth, however juvenile recruitment was exceptionally high the following June, similar to the findings by Strasser et al. (2001<sup>b</sup>). This pattern is often seen in bivalve species and leads to suggest harsh winters may be beneficial for recruitment success by encouraging greater egg production, or by changing the balance of species in the ecosystem thus reducing predation pressure (Strasser et al. 2001<sup>b</sup>). It is also possible that mortality affected the smaller individuals, leaving larger mature adults to replenish the stocks (Strasser et al. 2001<sup>a</sup>). Both theories may be influencing what was observed in the studies although other factors as previously suggested need to be included for a more accurate predictions for mortality.

#### **1.3.4 Parasites, Pathogens and Diseases**

*Cerastoderma edule*, plays an important role in the complex life cycle of some marine parasites. It is known to host around 50 species of parasites, pathogens and diseases throughout its distributional range (Longshaw and Malham, 2013). Infection of individual or multiple species can be highly prevalent within individual cockles or throughout the population (Lauckner, 1983; de Montaudouin et al., 2000; Thieltges, 2006; Longshaw and Malham, 2013). Infection by some species can either cause no obvious harm or negative impact to the cockle host or, depending upon species, can interfere with their growth and metabolism, disrupt burrowing or cause mass mortalities within the populations (Elliott et al., 2012; Malham et al., 2012). Although the parasites and diseases of cockles have been extensively studied, their direct impact on the cockle's health is remain relatively unknown as it is difficult to predict the exact causal relationships between any observed mortality or negative pathology due to many other environmental factors that have play a direct role in the cockle's lifecycle (Longshaw and Malham, 2013; Rowley et al., 2014; Presta et al., 2014). Species of most concern which can have a significant impact of the biomass of cockles belong to the following taxonomic groups: Digenea (*Bucephalus* spp. and *Gymnophallus* spp.); Haplosporidia (*Minchinia* spp.); Cercozoa (*Marteilia conchilia*); and other various bacteria and viruses (Longshaw and Malham, 2013; Rowley et al., 2014).

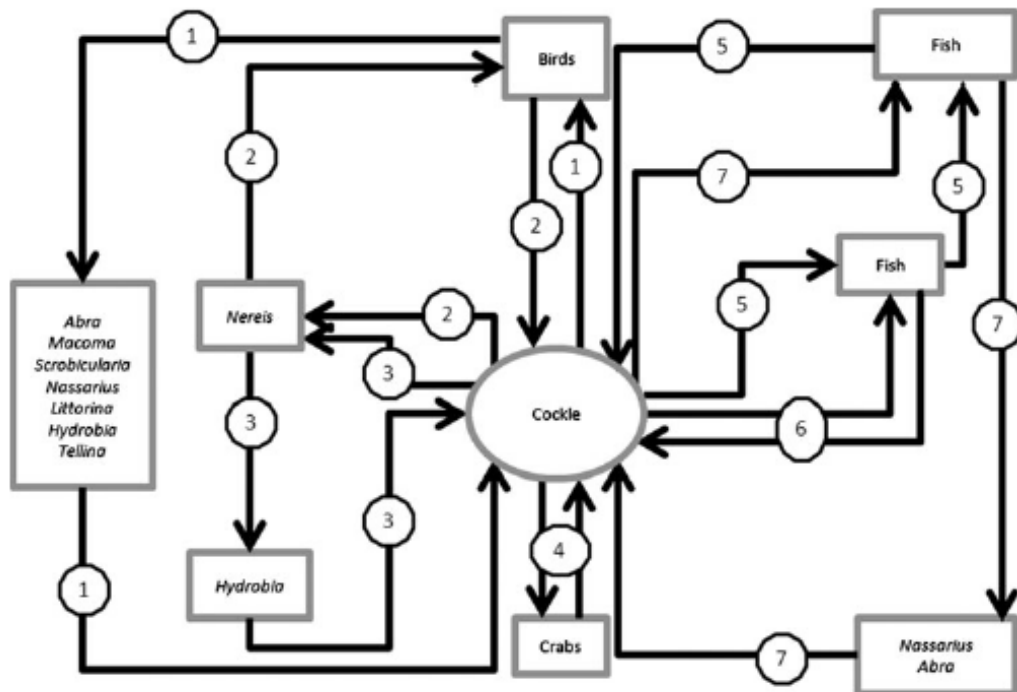
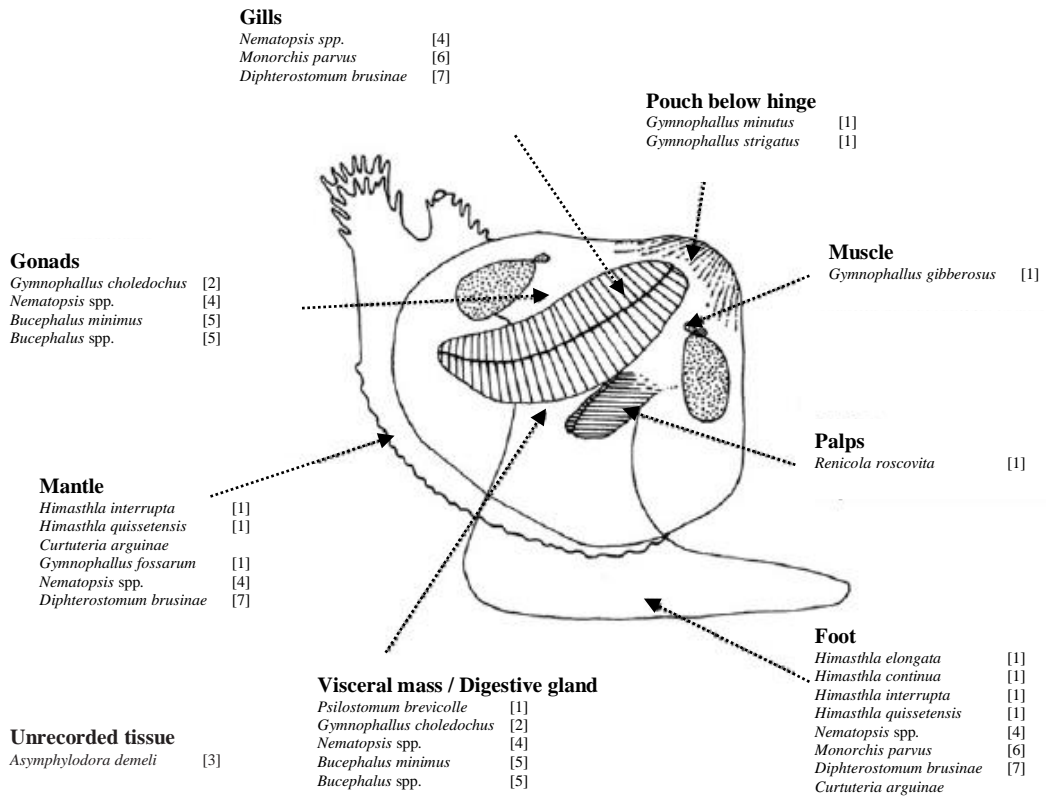
Parasites, pathogens and diseases play a functionally important role and are considered a biotic force, influencing a communities' biodiversity and its structuring across several trophic levels. *Cerastoderma edule* take the role of the first and/or second intermediate hosts to many

## Chapter 1

species, providing the link between the benthic and pelagic environment. Many larval stages of digenean trematodes infect cockles prior to transmission to their definitive host consisting of twelve species of birds and four species of fish where they mature into adults (de Montaudouin et al., 2009) (Fig. 2). Figure 2 illustrates the complex lifecycle pathways of the common species of digenea trematode parasites of *C. edule* and the tissue specific infection site. It is important to note that not all species are found in cockles in the United Kingdom.



# Chapter 1



**Figure 2.** Generalised location of the common parasites infecting *Cerastoderma edule* (top – redrawn from de Montaudouin et al., 2009) and the life cycle flow of these parasites. Numbers in [ ] (top) indicate life cycle pathway (bottom - taken from Longshaw and Malham, 2013).

#### 1.4 *Thesis Outline*

The overall aim of this thesis is to investigate the spatio-temporal variability of the biological and environmental processes that play a role in determining the health status of *Cerastoderma edule* during the larval and adult life cycle stages. The main objectives of this research were to: 1) take a place based approach and investigate differences between two distinctly separate cockle fisheries: one located in a large estuary on the North West England and North East Wales border; and the other a small scale fishery at the southern end of the Menai Strait, North West Wales; and 2) investigate how seasonality plays a role in mitigating the biological processes of *C. edule*. Chapter 2 gives an overview of four of the most productive cockle fisheries in the United Kingdom. It addresses the stock status over a 14-year period and describes the characteristics of each fishery. In Chapter 3, the growth and survival of larvae generated from mature adult cockles was assessed to determine the differences of larval quality between sites. The larvae were reared in the laboratory at three temperatures regimes and two different levels of microalgae to mimic different environmental conditions they would experience at different points of in the spawning season. The aim was to quantify their growth through to metamorphosis in larval populations spawned from two separate adult stocks and the results would identify environmental conditions when survival and recruitment to a population may be more successful. In Chapter 4, the cockle fisheries were assessed for parasite community structure present in commercially sized cockles. The aim was to identify the different species observed within each fishery and the impact they can have on the health of cockles at an individual and population scale. The temporal change in parasite community structure was also assessed to determine time of the year when infection occurs. Chapter 5 uses the same cockles screened in Chapter 4 and takes a biochemical approach to quantify their energy status. The main aim was to test if cockles from different sites have different energetic contents and how this can vary over the course of a year. Chapter 6 brings together the results from all previous data chapters in context with the main objectives of this thesis and previously published research.

#### 1.5 *Selection criteria for the cockle fisheries used in this research*

Each of the cockle fisheries that provided samples of *Cerastoderma edule* for this research was selected based on a number of factors: 1) the relative close proximity to the laboratories at the School of Ocean Sciences, Bangor University; 2) the total area and biomass available to the cockle fishery & 3) the different environmental conditions and physical

## Chapter 1

dynamics experienced at each location. The Dee estuary was chosen as it has a long history of commercial exploitation and receives annual high intensity fishing pressure. It consists of multiple cockle beds spread over a large area. The habitats within the estuary are heavily influenced by the outflow of the River Dee which has a catchment area of 2,251 km<sup>2</sup>, covering much of North East Wales and Cheshire. The estuary receives high levels of anthropogenic influence as there is a high human population along the shores and lower catchment area as well as industrial development towards southern end of the estuary (Kershaw and Campos, 2009). The Dee estuary cockle fishery is classified as B by the Food Standards Agency (FSA) (Davies, 2013).

Traeth Melynog is much the opposite of what is found in the Dee Estuary. It is a sheltered bay on the south western coast of the Isle of Anglesey and could be classed as being a pristine environment in comparison. It is part of the Newborough Warren – Ynys Llanddwyn Site of Special Scientific Interest and as an intertidal area of 330 ha fringed by narrow saltmarsh and extensive sand dune systems (Sunderland, 1982a). The shallow bay of Traeth Melynog supports a small population of *C. edule* that is fished annually but limited to a total allowable catch of 168 tonnes. It's location on the Menai Strait means it experiences a high transfer of seawater during the flood and ebbing tides. Traeth Melynog cockle fishery is not classified under the FSA (Davies, 2013).

## 1.5 References

- Andre, C. & Lindegarth, M., 1995. Fertilization efficiency and gamete viability of a sessile, free-spawning bivalve, *Cerastoderma edule*. *Ophelia*, 43(3), pp.215–277.
- Ansell, A., Barnett, P. & Masse, H., 1981. Upper temperature tolerances of some European molluscs. *Marine Biology*, 65, pp.177–183.
- Aranda-Burgos, J.A. et al., 2014. Effects of microalgal diet on growth, survival, biochemical and fatty acid composition of *Ruditapes decussatus* larvae. *Aquaculture*, 420-421, pp.38–48.
- Baggerman, B., 1953. Spatfall and transport of *Cardium edule* L. *Netherlands journal of zoology*, 10(3), pp.316–342.
- Bayne, B., 1965. Growth and the delay of metamorphosis of the larvae of *Mytilus edulis* (L.). *Ophelia*, 2(1), pp.1–47.
- Bolaños, R. and Souza, A., 2010. Measuring hydrodynamics and sediment transport processes in the Dee Estuary. *Earth system science data*, 2(1), pp.157-165.
- Boyden, R., 1971. A note on the nomenclature of two European cockles. *Zoological Journal of the linnean society*, 50, pp.307–310.
- Boyden, C.R., 1972. The behaviour, survival and respiration of the cockles *Cerastoderma edule* and *C. glaucum* in air. *Journal of the marine biological association of the United Kingdom*, 52(03), p.661.
- Brock, V., 1979. Habitat selection of two congeneric bivalves, *Cardium edule* and *C. glaucum* in sympatric and allopatric populations. *Marine biology*, 54(2), pp.149–156.
- Burdon, D., Callaway, R., Elliott, M., Smith, T. and Wither, A., 2014. Mass mortalities in bivalve populations: A review of the edible cockle *Cerastoderma edule* (L.). *Estuarine, coastal and shelf science*, 150, pp.271-280.
- Callaway, R. et al., 2013. The riddle of the sands: how population dynamics explains causes of high bivalve mortality. *Journal of applied ecology*, 50(4), pp.1050–1059.
- Camphuysen, C.J. et al., 2002. Mass mortality of common eiders (*Somateria mollissima*) in the Dutch Wadden Sea, winter 1999 / 2000: starvation in a commercially exploited wetland of international importance. *Biological conservation*, 106, pp.303–317.
- Cardoso, J.F.M.F., Witte, J.I. & van der Veer, H.W., 2009. Differential reproductive strategies of two bivalves in the Dutch Wadden Sea. *Estuarine, coastal and shelf science*, 84(1), pp.37–44.
- Cesar, C., 2009. The roles of the cockle *Cerastoderma edule* L. on ecosystem functioning: cockle comings and goings. *University of Liverpool*, pp.179
- Ciutat, A., Widdows, J. & Pope, N.D., 2007. Effect of *Cerastoderma edule* density on near-bed hydrodynamics and stability of cohesive muddy sediments. *Journal of experimental marine biology and ecology*, 346(1-2), pp.114–126.
- Compton, T.J. et al., 2009. Repeatable sediment associations of burrowing bivalves across six European tidal flat systems. , 382, pp.87–98.
- Coscia, I. et al., 2012. Modelled larval dispersal and measured gene flow: seascape genetics of the common cockle *Cerastoderma edule* in the southern Irish Sea. *Conservation genetics*, 14, pp.451–466.
- Creek, G.A., 1960. The development of the lamellibranch *Cardium edule* L. *Proceedings of the zoological society of London*, 135(2), pp.243–260.
- Dabouineau, L. & Ponsoero, A., 2011. Synthesis on biology of common European cockle *Cerastoderma edule*.
- Dare, P.J. et al., 2004. Historical and current status of cockle and mussel stocks in The Wash.

## Chapter 1

- Dare, P.J. & Mercer, a. J., 1973. Foods of the Oystercatcher in Morecambe Bay, Lancashire. *Bird study*, 20(3), pp.173–184.
- Davies, C., 2013. A Further Review of the Management of Cockle Fisheries in Wales. Natural Resources Wales. Available at: <https://naturalresources.wales/media/1678/review-management-cockle-fisheries-wales.pdf>.
- de Montaudouin, X., 1996. Factors involved in growth plasticity of cockles *Cerastoderma edule* (L.), identified by field survey and transplant experiments. *Journal of sea research*, 36(3-4), pp.251-265.
- de Vlas, J., 1979. Annual food intake by plaice and flounder in a tidal flat area in the Dutch Wadden Sea, with special reference to consumption of regenerating parts of macrobenthic prey. *Netherlands Journal of sea research*, 13(1), pp.117-153.
- Desclaux, C., De Montaudouin, X. and Bachelet, G., 2002. Cockle emergence at the sediment surface: ‘favourization’ mechanism by digenean parasites? *Diseases of aquatic organisms*, 52(2), pp.137-149.
- Desprez, M. et al., 1992. Biological Impact of eutrophication in the bay of somme and the induction and impact of anoxia. *Netherlands Journal of sea research*, 159(June 1989), pp.149–159.
- Donadi, S., van der Zee, E.M., van der Heide, T., Weerman, E.J., Piersma, T., van de Koppel, J., Olf, H., Bartelds, M., van Gerwen, I. and Eriksson, B.K., 2014. The bivalve loop: intra-specific facilitation in burrowing cockles through habitat modification. *Journal of experimental marine biology and ecology*, 461, pp.44-52
- Elliott, M., Burdon, D., Callaway, R., Franco, A., Hutchinson, T., Longshaw, M., Malham, S., Mazik, K., Otto, Z., Palmer, D. and Firmin, C., 2012. Burry Inlet cockle mortalities investigation 2009–2011 (p. 337). Final Technical Report to Environment Agency (Wales), 17 January 2012. Available online at: [http://a0768b4a8a31e106d8b0-50dc802554eb38a24458b98ff72d550b.r19.cf3.rackcdn.com/gewa0112bwap-ee.pdf/742793/UK\\_Sea\\_Fisheries\\_Statistics\\_2017.pdf](http://a0768b4a8a31e106d8b0-50dc802554eb38a24458b98ff72d550b.r19.cf3.rackcdn.com/gewa0112bwap-ee.pdf/742793/UK_Sea_Fisheries_Statistics_2017.pdf)
- Epelbaum, A. et al., 2011. Effects of stocking density and substratum on the survival, growth, burrowing behaviour and shell morphology of juvenile basket cockle, *Clinocardium nuttallii*: implications for nursery seed production and field outplanting. *Aquaculture research*, 42(7), pp.975–986.
- Eriksson, B.K. et al., 2010. Major Changes in the Ecology of the Wadden Sea: Human Impacts, Ecosystem Engineering and Sediment Dynamics. *Ecosystems*, 13(5), pp.752–764.
- Ferns, P.N., Rostron, D.M. & Siman, H.Y., 2000. Effects of mechanical cockle harvesting on intertidal communities. *Journal of applied ecology*, pp.464–474.
- Flach, E.L.S.C., 1996. The Influence of the cockle, *Cerastoderma edule*, on the Macrozoobenthic Community of Tidal Flats in the Wadden Sea. *Marine Ecology*, 17(1-3), pp.87–98.
- Franklin, A., 1972. The cockle and its fisheries, Ministry of Agriculture, Fisheries and Food, Lowestoft, pp.37.
- Galley, T.H., Batista, F.M., Braithwaite, R., King, J. and Beaumont, A.R., 2010. Optimisation of larval culture of the mussel *Mytilus edulis* (L.). *Aquaculture international*, 18(3), pp.315-325.
- Gam, M. et al., 2008. Metazoan parasites in an intermediate host population near its southern border: the common cockle (*Cerastoderma edule*) and its trematodes in a Moroccan coastal lagoon (Merja Zerga). *Journal of the Marine Biological Association of the UK*, 88(02), pp.357–364.
- Genelt-Yanovskiy, E. et al., 2010. Population structure and growth rates at biogeographic extremes: a case study of the common cockle, *Cerastoderma edule* (L.) in the Barents Sea. *Marine pollution bulletin*, 61(4-6), pp.247–53.
- Gosling, E., 2003. Ecology of Bivalves. Bivalve molluscs: biology, ecology and culture. Fishing news books, Blackwell, Oxford, pp.44-86.
- Goss-Custard, J.D. et al., 2004. When enough is not enough: shorebirds and shellfishing. *Proceedings of the royal society London*, 271(1536), pp.233–7.
- Grant, M.N., Meritt, D.W. & Kimmel, D.G., 2013. Chemical induction of settlement behavior in larvae of the eastern oyster *Crassostrea virginica* (Gmelin). *Aquaculture*, 402-403, pp.84–91.

## Chapter 1

- Guevara, J. & Niell, F., 1989. Growth rates in a continuously immersed population of *Cerastoderma edule* L. *Topics in Marine biology*, 53(2-3), pp.483–489.
- Gyory, J., Pineda, J. & Solow, A., 2013. Turbidity triggers larval release by the intertidal barnacle *Semibalanus balanoides*. *Marine ecology progress series*, 476, pp.141–151.
- Hancock, D., 1967. Growth and mesh selection in the edible cockle (*Cardium edule* L.). *British ecological society*, 4(1), pp.137–157.
- Hancock, D. & Franklin, A., 1972. Seasonal changes in the condition of the edible. *British ecological society*, 9(2), pp.567–579.
- Hancock, D.A. & Urquhart, A.E., 1964. Mortalities of edible cockles (*Cardium edule* L.) during the severe winter of 1962–1963. *Journal of animal ecology. Anim. Ecol*, 3, pp.176–178.
- Haven, D.S., 1966. Aspects of biodeposition by oysters and other invertebrate filter feeders. *Limnology and Oceanography*, 11(4), pp.487–498.
- Hayward, P. & Ryland, S., 1995. *Handbook of the Marine Fauna of North-West Europe*, Oxford University Press, pp.598.
- Helm, M.H. & Bourne, N., 2004. *Hatchery culture of bivalves, a practical manual*, FAO Fisheries Technical Paper 471, Rome, pp.203
- Honkoop, P.J.C. et al., 2008. Molluscan assemblages of seagrass-covered and bare intertidal flats on the Banc d'Arguin, Mauritania, in relation to characteristics of sediment and organic matter. *Journal of sea research*, 60(4), pp.235–243.
- House, M.R. and Farrow, G.E., 1968. Daily growth banding in the shell of the cockle, *Cardium edule*. *Nature*, 219(5161), p.1384.
- Howel, T. et al., 2008. *Survey of Solway cockle grounds 2007*, Fisheries research services, Aberdeen, pp.59.
- Huxham, M. & Richards, M., 2003. Can postlarval bivalves select sediment type during settlement? A field test with *Macoma balthica* (L.) and *Cerastoderma edule* (L.). *Journal of experimental marine biology and ecology*, 288, pp.279–293.
- Ibarrola, I., Larretxea, X., Iglesias, J.I.P., Urrutia, M.B. and Navarro, E., 1998. Seasonal variation of digestive enzyme activities in the digestive gland and the crystalline style of the common cockle *Cerastoderma edule*. *Comparative Biochemistry and Physiology Part A: Molecular & integrative physiology*, 121(1), pp.25-34.
- Iglesias, J.I.P., Navarro, E., Jorna, P.A. and Armentina, I., 1992. Feeding, particle selection and absorption in cockles *Cerastoderma edule* (L.) exposed to variable conditions of food concentration and quality. *Journal of experimental marine biology and ecology*, 162(2), pp.177-198.
- Jensen, K.T., 1992. Dynamics and growth of the cockle, *Cerastoderma edule*, on an intertidal mud-flat in the danish wadden sea: effects of submersion time and density. *Netherlands journal of sea research*, 28(4), pp.335–345.
- Jensen, K.T., 1993. Density-dependent growth in cockles (*Cerastoderma edule*): evidence from interannual comparisons. *Journal of the marine biological association of the United Kingdom*, 73(2), pp.333-342
- Jensen, K.T. & Jensen, J.N., 1985. The importance of some epibenthic predators on the density of juvenile benthic macrofauna in the Danish Wadden Sea. *Journal of experimental marine biology and ecology*, 89, pp.157–174.
- Jonsson, P., Andre, C. & Lindegarth, M., 1991. Swimming behaviour of marine bivalve larvae in a flume boundary-layer flow: evidence for near-bottom confinement. *Marine ecology progress series*, 79, pp.67–76.
- Jonsson, P., Andre, C. & Lindegarth, M., 1991. Swimming behaviour of marine bivalve larvae in a flume boundary-layer flow: evidence for near-bottom confinement. *Marine ecology progress series*, 79, pp.67–76.
- Jonsson, P.R. and Andé, C., 1992. Mass mortality of the bivalve *Cerastoderma edule* on the Swedish west coast caused by infestation with the digenean trematode *Cercaria cerastodermae* I. *Ophelia*, 36(2), pp.151-157.

## Chapter 1

Ke, X., G. E. & Collins, M., 1996. Hydrodynamics and sediment dynamics of The Wash embayment, eastern England. *Sedimentology*, 43, pp.157–174.

Kingston, P., 1973. Interspecific hybridization in *Cardium*. *Nature*, 243, p.360.

Kingston, P.F., 1974. Studies on the Reproductive Cycles of *Cardium edule* and *C. glaucum*. *Marine biology*, 28, pp.317–323.

Krakau, M. et al., 2011. The cockle *Cerastoderma edule* at Northeast Atlantic shores: genetic signatures of glacial refugia. *Marine Biology*, 159(1), pp.221–230.

Kreger, D., 1940. On the ecology of *Cardium edule* L. *Archives Néerlandaises de Zoologie*, 4, pp.157–200.

Kristensen, I., 1957. Differences in density and growth in a cockle population in the Dutch Wadden Sea. *Arch. Néerl. Zool.*, 12 (suppl. 3): 351-453. *Archives Néerlandaises de Zoologie.*, 12(3), pp.351–453.

Lebour, M., 1938. Notes on the breeding of some lamellibranchs from Plymouth and their larvae. *Journal of the marine biological association of the United Kingdom*, 23(01), pp.119–144.

Longshaw, M. & Malham, S.K., 2012. A review of the infectious agents, parasites, pathogens and commensals of European cockles (*Cerastoderma edule* and *C. glaucum*). *Journal of the marine biological association of the United Kingdom*, 93(01), pp.227–247.

Liu, W. et al., 2008. Seasonal variations in reproductive activity and biochemical composition of the cockle *Fulvia mutica* (Reeve) from the eastern coast of China. *BioOne*, 27(2), pp.405–411.

MacIntyre, H.L., Geider, R.J. and Miller, D.C., 1996. Microphytobenthos: the ecological role of the “secret garden” of unvegetated, shallow-water marine habitats. I. Distribution, abundance and primary production. *Estuaries*, 19(2), pp.186-201

Malham, S.K., Hutchinson, T.H. & Longshaw, M., 2012. A review of the biology of European cockles (*Cerastoderma* spp.). *Journal of the marine biological association of the United Kingdom*, 92(07), pp.1563–1577.

Le Mao, P., 1986. Feeding relationships between the benthic infauna and the dominant benthic fish of the Rance estuary (France). *Journal of the marine biological association of the United Kingdom*, 66, pp.391–401.

Martinez-Castro, C. & Vázquez, E., 2012. Reproductive cycle of the cockle *Cerastoderma edule* (Linnaeus 1758) in the Ria de Vigo (Galicia). *Journal of shellfish research*, 31(3), pp.757–767.

Mesías-gansbiller, C. et al., 2013. Effects of chemical cues on larval settlement of the flat oyster (*Ostrea edulis* L.): A hatchery approach. *Aquaculture*, 376-379, pp.85–89.

Montaudouin, X. De, Bachelet, G. & Sauriau, P., 2003. Secondary settlement of cockles *Cerastoderma edule* as a function of current velocity and substratum: a flume study with benthic juveniles. *Hydrobiologia*, 503, pp.103–116.

Moore, J.J. (2011). Survey of cockle stocks in the Burry Inlet, June 2011. A report to the Environment Agency Wales from Coastal Assessment, Liaison & Monitoring, Cosherton, Pembrokeshire. pp. 19

Morgan, E., O’ Riordan, R.M. & Culloty, S.C., 2013. Climate change impacts on potential recruitment in an ecosystem engineer. *Ecology and evolution*, 3(3), pp.581–94.

Murray, F. and Tarrant, P., 2015. A social and economic impact assessment of cockle mortality in the Burry Inlet and Three Rivers cockle fisheries, South Wales UK.

Newell, R.I.E. & Bayne, B.L., 1980. Seasonal changes in the physiology, reproductive condition and carbohydrate content of the cockle *Cardium* (= *Cerastoderma*) *edule* (Bivalvia: Cardiidae). *Marine biology*, 56, pp.11–19.

Norris, K., Bannister, R. & Walker, P., 1998. Changes in the number of oystercatchers *Haematopus ostralegus* wintering in the Burry Inlet in relation to the biomass of cockles *Cerastoderma edule* and its commercial exploitation. *Journal of applied ecology*, 35, pp.75–85.

## Chapter 1

- Nowell, A., Jumars, P. & Eckman, J., 1981. Effects of biological activity on the entrainment of marine sediments. *Developments in sedimentology*, 32, pp.133–153.
- O'Connor, R.J. and Brown, R.A., 1977. Prey depletion and foraging strategy in the oystercatcher *Haematopus ostralegus*. *Oecologia*, 27(1), pp.75-92.
- Orton, J., 1926. On the rate of growth of *Cardium edule*. Part 1 experimental observations. *Journal of the marine biological association of the United Kingdom*, 14(2), pp.239–279.
- Pechenik, J., 1979. Role of encapsulation in invertebrate life histories. *The American naturalist*, 114(6), pp.859–870.
- Pihl, L., 1985. Food selection and consumption of mobile epibenthic fauna in shallow marine areas. *Marine ecology progress series*, 22, pp.169–179.
- Presta, M.L., Cremonte, F. and Ituarte, C., 2014. The fit between parasites and intermediate host population dynamics: larval digeneans affecting the bivalve *Neolepton cobbi* (Galeommatoida) from Patagonia. *Marine biology research*, 10(5), pp.494-503.
- Pronker, A.E. et al., 2013. Hatchery cultivation of the common cockle (*Cerastoderma edule* L.): from conditioning to grow-out. *Aquaculture Research*, pp.1–11.
- Ramon, M., 2003. Population dynamics and secondary production of the cockle *Cerastoderma edule* (L.) in a backbarrier tidal flat of the Wadden Sea. *Scientia marina*, 67(4), pp.429–443.
- Reise, K., 1985. Tidal flat ecology. An experimental approach to species interaction. *Ecological studies*, 61, p.191.
- Richardson, C.A., Crisp, D.J. & Runham, N.W., 1979. Tidally deposited growth bands in the shell of the common cockle, *Cerastoderma edule*. *Malacologia*, 18(1-2), pp.277–290.
- Richardson, C. A., Crisp, D.J. & Runham, N.W., 1980<sup>a</sup>. Factors Influencing Shell Growth in *Cerastoderma edule*. *Proceedings of the Royal Society B: Biological sciences*, 210(1181), pp.513–531.
- Richardson, C.A., Crisp, D.J. & Runham, N.W., 1980<sup>b</sup>. An endogenous rhythm in shell deposition in *Cerastoderma edule*. *Journal of the marine biological association of the United Kingdom*, 60, pp.991–1004.
- Richardson, C.A., Ibarrola, I. & Ingham, R.J., 1993. Emergence pattern and spatial distribution of the common cockle *Cerastoderma edule*. *Marine ecology progress series*, 99, pp.71–81.
- Rowley, A.F., Cross, M.E., Culloty, S.C., Lynch, S.A., Mackenzie, C.L., Morgan, E., O'Riordan, R.M., Robins, P.E., Smith, A.L., Thrupp, T.J. and Vogan, C.L., 2014. The potential impact of climate change on the infectious diseases of commercially important shellfish populations in the Irish Sea—a review. *ICES Journal of marine science*, 71(4), pp.741-759
- Rueda, J.L. and Smaal, A.C., 2002. Selective ingestion of pelagic versus benthic algae by the cockle *Cerastoderma edule* (Linne, 1758). *Journal of shellfish research*, 21(2), pp.619-625.
- Rueda, J.L., Smaal, A.C. & Scholten, H., 2005. A growth model of the cockle (*Cerastoderma edule* L.) tested in the Oosterschelde estuary (The Netherlands). *Journal of sea research*, 54(4), pp.276–298.
- Ruppert, E., Fox, R. & Barnes, R., 2004. *Invertebrate Zoology - a functional evolutionary approach* Seventh., Brooks/Cole. pp.367-403.
- Russ, G.R. and Alcalá, A.C., 2011. Enhanced biodiversity beyond marine reserve boundaries: The cup spillith over. *Ecological applications*, 21(1), pp.241-250.
- Seed, R., 1969. The ecology of *Mytilus edulis* L. (Lamellibranchiata) on exposed rocky shores. *Oecologia*, 3, pp.277–316.
- Seed, R. & Brown, R., 1977. A comparison of reproductive cycles of *Modiolus modiolus* (L.), *Cerastoderma (=Cardium) edule* (L.), and *Mytilus edulis* L. in Strangford Lough, Northern Ireland. *Oecologia*, 30, pp.173–188.



## Chapter 1

- Sponaugle, S. et al., 2002. Predicting self-recruitment in marine populations: biophysical correlates and mechanisms. *Bulletin of maine science*, 70(1), pp.341–375.
- Steele, S. and Mulcahy, M.F.O., 1999. Gametogenesis of the oyster *Crassostrea gigas* in southern Ireland. *Journal of the marine biological association of the United Kingdom*, 79, pp.673–686.
- Strasser, M., Hertlein, A. & Reise, K., 2001a. Differential recruitment of bivalve species in the northern Wadden Sea after the severe winter of 1995/96 and of subsequent milder winters. *Helgoland Marine Research*, 55(3), pp.182–189.
- Strasser, M., Reinwald, T. & Reise, K., 2001b. Differential effects of the severe winter of 1995/96 on the intertidal bivalves *Mytilus edulis*, *Cerastoderma edule* and *Mya arenaria* in the Northern Wadden Sea. *Helgoland Marine research*, 55(3), pp.190–197.
- Sutherland, W.J. & Sutherland, B.Y.W.J., 1982a. Spatial variation in the predation of cockles by oystercatchers at Traeth Melynog, Anglesey. I. The cockle population. *Journal of animal ecology*, 51(2), pp.481–489.
- Sutherland, W.J. & Sutherland, B.Y.W.J., 1982b. Spatial variation in the predation of cockles by oystercatchers at Traeth Melynog, Anglesey. II. The pattern of mortality. *British ecological society*, 51(2), pp.491–500.
- Sweeting, C.J. and Polunin, N.V.C., 2005. Marine protected areas for management of temperate north Atlantic fisheries. Lessons learned in MPA use for sustainable fisheries exploitation and stock recovery. Report to DEFRA, UK. <http://archive.defra.gov.uk/environment/marine/documents/science/mpareport-northatlantic.pdf>.
- Thieltges, D.W., 2006. Parasite induced summer mortality in the cockle *Cerastoderma edule* by the trematode *Gymnophallus choledochus*. *Hydrobiologia*, 559(1), pp.455–461.
- Tyler-Walters, H., 2007. *Cerastoderma edule*. Common cockle. Marine Life Information Network: Biology and Sensitivity Key Information Sub-programme [on-line]. Plymouth: Marine biological association of the United Kingdom. Available from: <<http://www.marlin.ac.uk/speciesfullreview.php?speciesID=2924>>
- Troost, K., Veldhuizen, R., et al., 2008<sup>a</sup>. Can bivalve veligers escape feeding currents of adult bivalves? *Journal of experimental marine biology and ecology*, 358, pp.185–196.
- Troost, K., Kamermans, P. & Wolff, W.J., 2008<sup>b</sup>. Larviphagy in native bivalves and an introduced oyster. *Journal of sea research*, 60, pp.157–163.
- Utting, S.D. & Millican, 1997. Techniques for the hatchery conditioning of bivalve broodstocks and the subsequent effect on egg quality and larval viability. *Aquaculture*, 155, pp.45–54.
- Veer, H.W. Van Der, Feller, R.J. & Weber, A., 1998. Importance of predation by crustaceans upon bivalve spat in the intertidal zone of the Dutch Wadden Sea as revealed by immunological assays of gut contents. *Journal of experimental marine biology and ecology*, 231, pp.139–157.
- Verhulst, S. et al., 2004. Shellfish fishery severely reduces condition and survival of oystercatchers despite creation of large marine protected areas. *Ecology and society*, 9(17), pp.1–10.
- Wehrmann, A., 1999. Long-term survival of epibenthic *Cerastoderma edule* (L.) in bivalve clusters on backbarrier tidal flats, North Sea. *Senckenbergiana maritima*, 30(1-2), pp.47–61.
- West, A.D. et al., 2007. Predicting site quality for shorebird communities: A case study on the Wash embayment, UK. *Ecological modelling*, 202, pp.527–539.
- Whitton, T., 2013. Processes controlling spatial and temporal variations in cockle *Cerastoderma edule* (L.) abundance and distribution, Bangor University, pp.123
- Wolff, W.J. et al., 1993. Biomass of macrobenthic tidal flat fauna of the Banc d'Arguin, Mauritania. *Hydrobiologia*, 258(1-3), pp.151–163.
- Yankson, K., 1986. Reproductive cycles of *Cerastoderma glaucum* (bruguère) and *C. edule* (L.) with special reference to the effects of the 1981–82 severe winter. *Journal of molluscan studies*, 52, pp.6–14.

## *Chapter 1*

Young, E. et al., 1998. A modelling study of environmental influences on bivalve settlement in The Wash, England. *Marine ecology progress series*, 172, pp.197–214.

## **An overview of the four largest cockle fisheries in England and Wales over the past 14 years**

### **2. Abstract**

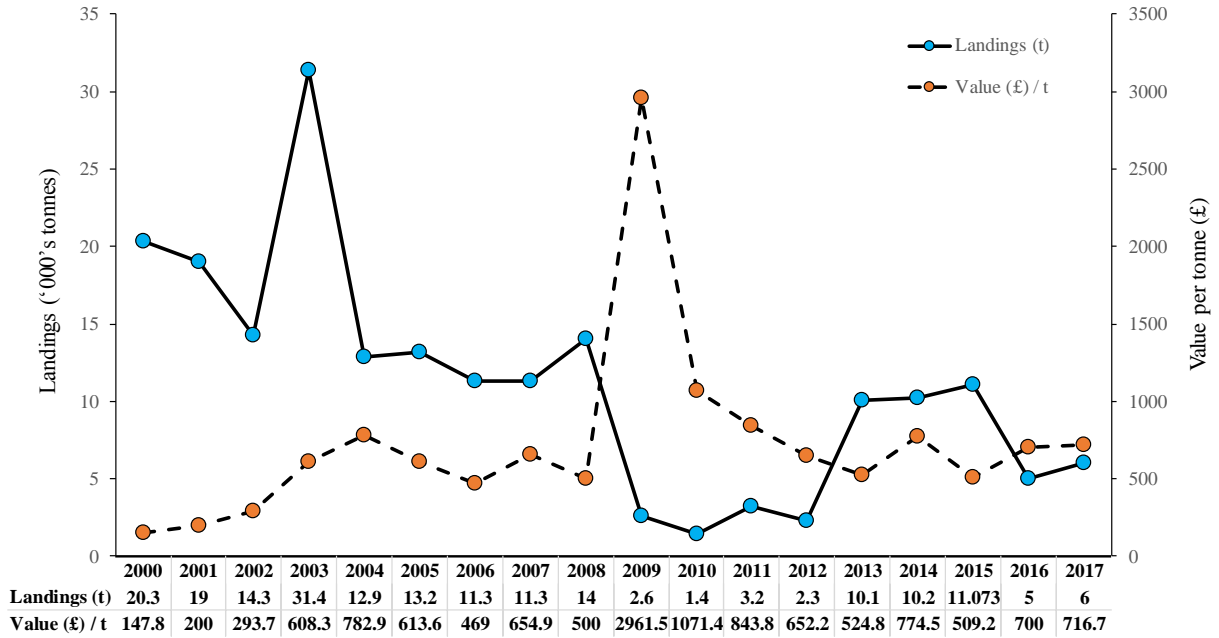
The cockle industry in the UK has a long-standing history and the current estimated value to the economy exceeds £4m per year. Four fisheries (Dee estuary, Burry Inlet, the Wash and Thames estuary) contribute a significant proportion of cockles to the total landings into the UK each year. To maintain and enhance the sustainability and health of the cockle stocks, the management is the responsibility of local authorities who develop byelaws and perform annual stock assessments which are tailored to the fishery itself. Mass mortality events in cockles can be unpredictable and are a threat to some fisheries, drastically reducing their biomass and forcing closures. It is therefore vital management practises can incorporate both the natural and human induced pressures in order to mitigate against any sudden loss of cockles. This overview briefly looks the characteristics of each of the four fisheries and addresses the impact of mortality events. It uses annual survey data collected from the relevant management authorities to show how estimated biomass (adults and juvenile cockles) has changed over a 13-year period (2004 – 2017). On the east coast of the UK, the Wash benefits from consistently high juvenile recruitment but mortalities can be linked to competition and localised high densities. The Thames estuary is the largest and most productive cockle fishery in the UK and suffers least from any impacts of mass mortality events. On the west coast of the UK, the Burry Inlet has suffered from periodic parasite induced mass mortalities and adult stocks have been slow to recovery. The biomass in the Dee estuary has in recent years stabilised after a period of poor recruitment and now supports high densities of cockles for the total area fished.

### **2.1. Importance of *Cerastoderma edule* to the UK commercial shellfish industry**

Gathering shellfish along the coastlines of the United Kingdom can be traced back to the end of the last Ice age, around 12,000 years ago, when the movement of settlers begun to re-colonise the land as ice sheets retreated. On the western coastline archaeological digs have found evidence of human shellfish consumption by the presence of mollusc shell middens that can be dating back to the Mesolithic period (Woolmer, 2010). Fisheries of *Cerastoderma edule* have been exploited since Roman times. More recently, these fisheries have expanded into a large industry that is not only important commercially, but has important ecological

implications as well. This is due to human activities that modify the sediment, which have an impact on the recoverability of cockle stocks and on the environment as a whole (Donadi et al., 2014). In some instances, gathering of cockles has outgrown the natural production (i.e. in the Burry Inlet), and the sustainability of the cockle beds is forcing bed closures. Coupled with the pressure of competition from wading birds (Camphuysen et al. 2002; Morgan et al., 2013) and the current and predicted impact of climate change (Callaway et al., 2012), there is an ever-increasing demand for the correct management of the fisheries in order to sustain their ecological and commercial value.

To date, the commercial exploitation of *Cerastoderma edule* in the UK is worth a little over £4 million (2017), with a long-term average of over £6 million per year. The total shellfish landings per year between the years 2000 – 2017 into UK ports by UK fishing vessels, was on average 142,000 tonnes  $y^{-1}$  ( $\pm 11$ ). Of which, *C. edule* contributed on average 11 tonnes  $y^{-1}$  ( $\pm 8$ ) (Elliott and Holden, 2017). Out of the total shellfish catch per year into the UK, the landings of *C. edule* make up around 15% ( $\pm 10$ ) of the total weight (tonnes), however their value per tonne in relation to other shellfish species (e.g. *Pecten maximus*, the king scallop) is low, accounting for only 2.7% ( $\pm 2.3$ ) of the estimated shellfish value per tonne  $y^{-1}$  (Fig. 1) (Elliott and Holden, 2017). There have been some unusual peaks in both landings and value of cockles during this 17-year period. The highest landings of 31,000 tonnes was recorded in 2003, however this did not seem to affect the value (Fig. 1). In 2009, the opposite relationship is seen. Landings were one of the lowest seen which had a significant impact on the value of cockles and increased significantly (Fig. 2) (Elliott and Holden, 2017).



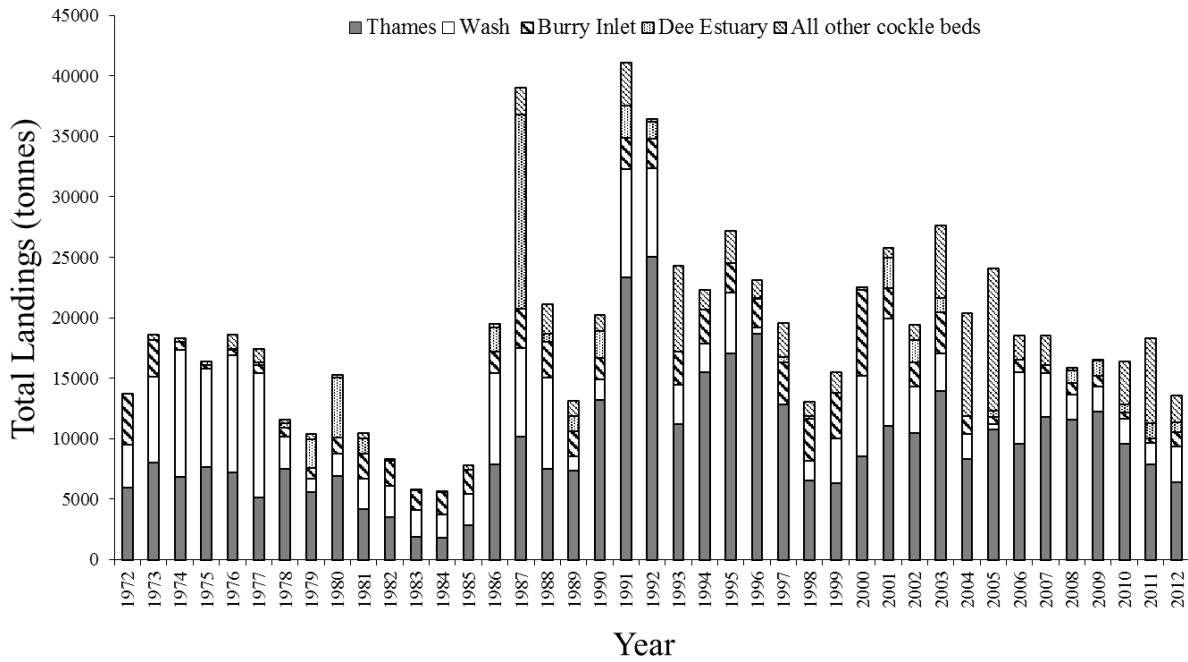
**Figure 1.** Total landings (in ‘000’s) of cockles into the UK ports (solid line – blue dots) and the value (£) of cockles per tonne (dotted line – orange dots). Data collated from the Marine Management Organisation annual UK Sea Fisheries statistics reports from 2000 – 2017 (Elliott and Holden, 2017).

In England and Wales, management of the cockle fisheries are managed by the local association of Inshore Fisheries and Conservation Authority (IFCA – England only) or in Wales, by Natural Resources Wales (NRW). These governing bodies are responsible for producing and improving local fisheries byelaws which aim to promote best management practices and protect the health of the wider marine environment, of which each commercial fishery depends upon (Wilson, 2009). They are all designated under the EC Shellfish Waters Directive (2006/113/EC) and the approved commercialisation of their fishery is dependent upon regular bacterial monitoring programs to ensure the shellfish in the fishery are fit for human consumption and can be certified by the Food Standards Authority. There are four cockle fisheries that make up the largest proportion of the total landings of *Cerastoderma edule* in the UK each year: 1) the Dee Estuary, 2) the Burry Inlet, 3) the Wash and 4) the Thames Estuary (Fig. 2).

## 2.2 *Impact of mortality on UK cockle fisheries*

Cockle populations are known to suffer large-scale periodic mortality events that can have a significant impact on the fishery, forcing closures to beds as biomass becomes low. Such events have been reported over the past 80 years and are not necessarily location dependant as they have been shown to occur across the UK and Europe (Malham et al., 2012). Such mortality events have been recorded from seventeen cockle fisheries in the England and Wales prior to 2013 (Burdon et al. 2014). They can be divided into two groups, typical and atypical mortality. Typical mortality refers to events that are common or expected and occur on a small-localised scale that has little effect on the population structure. They generally do not have any long-term impact on cockle stocks but may present a clear cause responsible for the mortality (Woolmer et al., 2013). Atypical mortality refers to events that are sudden and unexpected which may reoccur each year. Atypical events can be mass mortality events, removing a significant proportion of the population. There is often no obvious cause; however, sudden weather extremes are an example of a natural stress that may be indicative of an atypical event. (Woolmer et al., 2013; Burdon et al., 2014). A number of abiotic factors have been associated with mortalities of *C. edule*, these include: deterioration in water quality, eutrophication, sedimentation; temperature, salinity, density and extreme weather events such as storms or climate change (Ducrotoy et al., 1989; Malham et al., 2012; Callaway et al., 2013; Woolmer et al., 2013; Burdon et al., 2014;). Some biotic factors that are suspected to affect mortality and may contribute to mass mortality events include a reduction in the cockle's energy as a result of an abiotic influence, pathogenic and parasitic infections, recruitment failure and predation (Beukema and Dekker, 2005; Longshaw and Malham, 2013; Woolmer et al., 2013).

## Chapter 2



**Figure 2.** Total landings in tonnes for the four of the most productive cockle producing fisheries in the United Kingdom from 1972 – 2012. All other cockled beds include Morecombe Bay, Ribble Estuary, Wirral Estuary & Three Rivers (South Wales). Data from the Marine Management Organisation.

**Table 1:** Summary of management details from the four cockle fisheries that make up a significant proportion of the UK’s total landings of *Cerastoderma edule* (adapted from Elliott et al., 2012).

Cockle Fishery	Managed by:	Permit required for commercial fishing	Type of fisheries	Minimum size	Total Allowable Catch	Daily catch limit	Limited seasons	Mean survey area (km <sup>2</sup> ) / y <sup>-1</sup>	Mean total biomass (t) / y <sup>-1</sup> (±1 SD)
Dee Estuary	NRW	Yes	Hand gathered	20mm SL	Yes	No	Yes	5.9	8250 (±6784)
Burry Inlet	NRW	Yes	Hand gathered	19mm SL or 10 mm SW	Yes	Yes	No	13.9	8301 (±4606)
Wash	Eastern IFCA	Yes	Dredged / Hand gathered	16 mm SW	Yes	Yes	Yes	43.5	11064 (±6283)
Thames Estuary	Kent and Essex IFCA	Yes	Dredged / Hand gathered	16 mm SW	Yes	Yes	Yes	119.5	39507 (±11813)

SL= Shell length, SW = Shell width, NRW = Natural Resources Wales, IFCA = Inshore Fisheries and Conservation Authority



**Figure 3.** Total biomass of *Cerastoderma edule* (all size classes) and total biomass of adult cockles from four of the biggest cockle producing fisheries in the United Kingdom. Biomass calculated per km<sup>2</sup> of total area surveyed during each of the annual spring surveys 2004 to 2017. Source of data: Natural Resources Wales, Eastern IFCA, Kent and Essex IFCA

## 2.3 Cockle fishery overview

### 2.3.1 Dee Estuary

The Dee Estuary is a northwest facing funnel shaped estuary managed by Natural Resources Wales (NRW) that spans the Welsh and English boarder, flowing out into Liverpool Bay. It is a large estuary of over 13,600 ha and contains large extensive intertidal sand banks and mud flats divided by deep channels (Natural England, 2010). The flow from the estuary is flood dominant which creates a silty and sandy environment, depositing mounds of silt onto the tidal flats (Bolaños and Souza 2010; Pontee et al., 2013). The Dee estuary is recognised nationally and internationally as a Site of Special Scientific Interest (SSSI) under Section 28 of the Wildlife and Countryside Act 1981 for the important habitats and species found there. These include, but not limited to, its bird populations, the intertidal sand and mud flats and the



saltmarsh habitats. The Dee estuary provides a refuge to overwintering birds and as a staging post to migratory birds. It is considered one of the most important estuaries in Britain and Europe for its populations of waders and wildfowl and is designated as a Ramsar Site under the Ramsar Convention of Wetlands of International Importance and as a Special Protection Area (SPA) under the EC Birds Directive (2009/147).

The Dee estuary supports a large biomass of *C. edule* relative to the total size of the estuary and has a yearly mean biomass of 8250 tonnes (Table. 1). Biomass of *C. edule* per km<sup>2</sup> is much higher than the other three major cockle fisheries (Fig. 3) and the cockles are distributed across 13 identified cockle beds (Fig. 4). Over the years, as new beds have been included in the annual survey's, the biomass estimates encompass a larger area (Fig. 4). The cockle fishery in the Dee estuary is considered to be relatively stable and sustainable since 2008, when the number of permits allocated to commercial fishermen were restricted to just 50 (reduced from over 1000) (Woolmer et al., 2013). Prior to 2008, the Dee estuary suffered intense fishing pressure that significantly reduce the cockle numbers in the fishery and the recovery rate for the stock was reduced. Typical mortality of cockles in the Dee estuary has been observed over the years but is not considered widespread throughout the whole estuary or have a significant effect on the total population. Early observations in 1933 identified dead or moribund (observed on the surface of the sediment and unable to burrow) cockles post-spawning season when temperatures had been higher than normal (Orton, 1933). The cause of these was not formally identified but the authors ruled out any pathogenic effect. More recently, mortalities of cockles over 1 year old in 2009 have been linked to an infestation of barnacles interfering with in cockle shell valves and resulting in localised 75% mortality rates; high temperatures leading to 90% mortality due to the effect of smothering of algae and competition between *Mytilus edulis* (Burdon et al., 2014). These mortalities were only found on the eastern side of the estuary (West Kirby and Thurstaston beds) (Fig. 4). Survey methodology has not changed from 2004 – 2017 and therefore comparisons of biomass across years can be made in the data provided from the yearly survey reports.

### 2.3.2 *Burry Inlet*

The Burry Inlet in south wales is managed by Natural Resources Wales and forms part of four statutory designations that are in place covering the cockle fishery and wider area. These include: 1) the Carmarthen Bay and Estuaries Special Area of Conservation (SAC), designated because of the shallow inlets and bays, sandbanks, mudflats and estuarine habitats that can be

found there; 2) the Burry Inlet and Carmarthen Bay Special Protected Area (SPA) as it plays a vital role in supporting wild fowl populations and overwintering birds of national and international importance; 3) designated as a Ramsar Site under the Ramsar Convention of Wetlands of International Importance and 4) the Burry Inlet and Loughor Estuary Site of Special Scientific Interest (SSSI) due to the large complex estuarine habitat comprising of grazed saltmarsh, sand and mud flats which have a significant contribution to the wildfowl populations. The SSSI covers almost 5900 ha and includes all the Burry inlet cockle fishery. The average total biomass from 2004 – 2017 was similar to the Dee estuary at 8301 tonnes (Table. 1). The fisheries cockle beds consist of extensive tidal flats and the inlet has seven recognised areas where collection is targeted (Fig. 5). The beds are also divided by the Loughor River that forms a natural barrier during low tidal periods. Up to 2010, annual cockle surveys were conducted by the Centre for Aquaculture and Fisheries Science (CEFAS) who recorded data on cockles measuring 25mm shell length. The methodology was based on transects running from high to low shore, however the location of these transects change from year to year. From 2011, the Welsh Environment Agency, who managed the fishery at the time, contracted out the surveys and the data collection methods changed to predefined sampling stations, evenly distributed throughout each bed to provide a greater accuracy in the biomass estimations and also begun recording the biomass in year classes rather than shell lengths. Boundaries for each of the beds was defined based on cockle densities (Moore, 2011). While this methodology is still used to present day, since 2011, there has been two changes in contractors conducting the surveys and the biomass data presented in the reports to Natural Resources Wales no longer distinguishes between the beds. This makes identifying patterns across years difficult. Over time adult stock of the Burry Inlet cockle fishery have suffered cyclical mortality events which are concentrated to cockles over 14mm in shell length or those older than 1 year old and can be wide spread throughout the fishery. These events can be dated back to the 1960's and can be linked to the infection of parasites and harsh conditions in the winter months (Bowers, 1969; Hancock & Urquhart 1965, Malham et al., 2012). More recently, high densities and parasite loading coinciding with post-spawning have been identified as possible causes (Burdon et al., 2014). Each year, mortality events follow a similar pattern, beginning in April and May with cockles observed moribund or dead on the surface.

Mortality may be localised at first but gradually spread throughout the fishery and its impact can affect up to 90% of the population over 14 mm shell length (Woolmer et al., 2013). This has a significant effect on the long-term stability of the fishery. To mitigate against these annual mortality events and loss in revenue from the fishery, fisheries management has had to

adapt so that the fishery can remain open. These include reducing the commercial size limit and allowing the collection and sale of cockles collected through a riddle with a gauge aperture of 10mm, temporarily removing an annual catch limit for fishers and not allocating a closed season (Table. 1). In 2017 the total biomass of the Burry Inlet for all size classes was over 20,000 tonnes. This is greater than previous years and may be a sign of high recruitment and/or less mortality from the previous year. However, it must be noted that distinguishing between size classes is difficult as this data is not reported in the survey reports for 2011 – 2017 (Fig. 5). Effective fishery management is particularly important as the Burry Inlet may be considered to be a self-replenishing population (Coscia et al., 2012) and therefore population crashes may be slow to recover.

### 2.3.3 *The Wash*

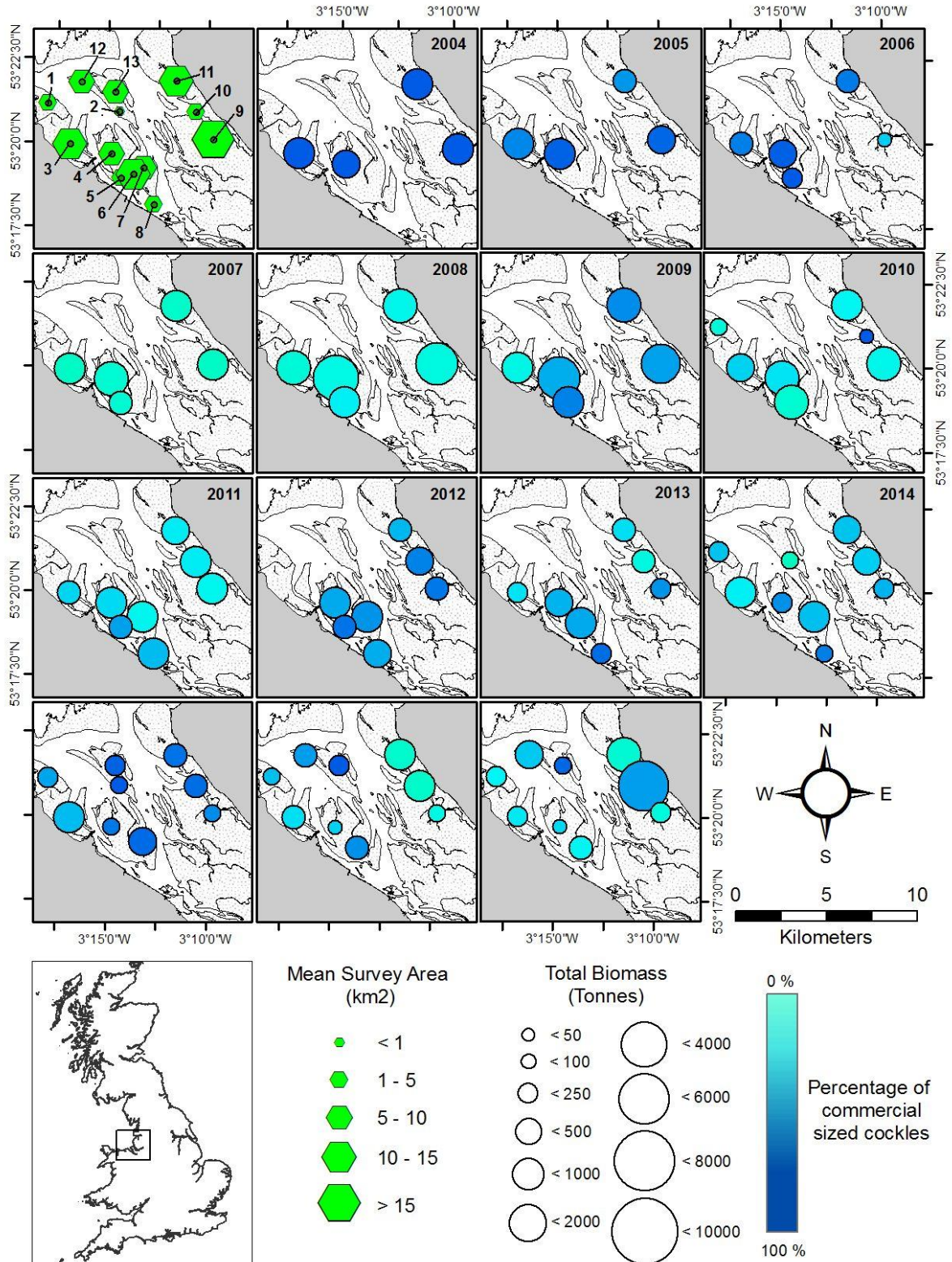
The Wash is a northeast facing embayment in eastern England along the Lincolnshire to Norfolk coastline. It is characterised by large tidal flats which form the Wash SSSI that covers an area over 63,000 ha. The Wash is also overlapped by the designations: The Wash and Norfolk Coast SAC; The Wash SPA and The Wash Ramsar. It has received this designation due to the habitats and species present and its importance to resident, migratory and overwintering bird populations. The cockle fishery in the Wash is regulated by the Eastern IFCA and the data provided in the annual reports is consistent across years. The Wash supports a large biomass of *C. edule* with a mean of just over 11,000 tonnes from 2000 - 2017 (Table. 1). Because of its large area, the Wash has less total biomass per km<sup>2</sup> when compared to the fisheries in Wales (Fig. 3), however, densities within individual beds can be high and the carrying capacity of the beds may be exceeded (Burdon et al., 2014). The western shores of the embayment generally have a higher biomass than those on the eastern side and may be related to the flow dynamics of the bed (Dare et al., 2004) (Fig. 6), and settlement of larvae during the spawning season. Dependent upon environmental conditions, the width of the embayment has an effect in determining the environmental role on larval recruitment. Larvae dispersal and recruitment is enhanced, and the fishery is considered self-replenishing when onshore winds from the N and NE coincide with larvae in the water column (Young et al., 1998). It has been reported that high spatfall follows a biannual pattern and leads to the strongest year classes produced every other year (Woolmer et al., 2013). This is noticeable in the biomass data for 2005 - 2006, and 2015 – 2016 (Fig. 6). The Wash has seen atypical mortality events throughout the years that mainly coincide with the post-spawning period and elevated temperatures (Burdon et al., 2014). Annual mortalities since 1987 were observed by Atkinson et al., (2003)

however there was no link to any environmental or pathogenic causes. From 2008 – 2011, mortality events effecting cockles over 1 year old were observed in the Wash and linked to density and competition between cockles. These ranged between 35- 90% (2008) (Fig. 6) and accounted for over 26,000 tonnes of *C. edule* during the 4-year period (Woolmer et al., 2013). Mortalities have also been linked to pathogenic influences e.g. haplosporidian infection (Burdon et al., 2014; Longshaw, 2015; Jessop – personal communication). Recently, stocks in the wash have recovered and 2016 saw the highest recorded biomass for all year classes at over 55,000 tonnes (Fig. 6).

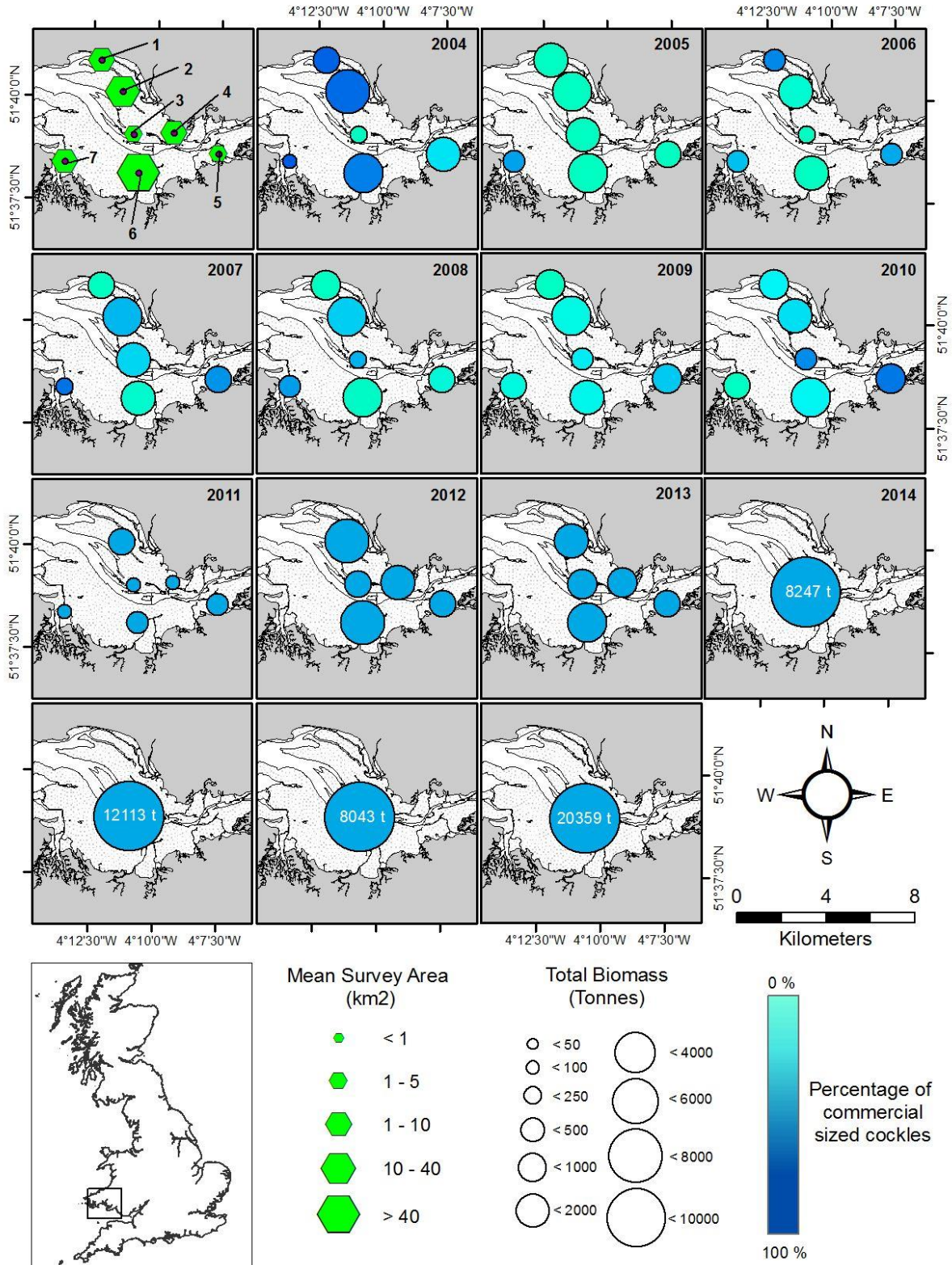
#### **2.3.4 Thames Estuary**

The Thames estuary is the largest managed cockle fishery in the United Kingdom producing a significant proportion of the total landings each year (Fig. 2). The fishery is regulated by the Kent and Essex IFCA and forms part of: 1) Thames Estuary and Marshes and the Outer Thames Estuary SPA's, 2) Thames Estuary and Marshes Ramsar site and 3) the South Thames Estuary and Marshes SSSI (5449 ha). Like all other cockle fisheries discussed, the area is designated and particularly important because of its importance to bird populations, with *C. edule* being a significant food source. The total mean annual biomass of *C. edule* in the Thames estuary is almost four times larger than found in the Wash, at over 39,000 tonnes (Table 1). Holding a large proportion of the biomass are the beds located along the Essex coastline in the northern part of the estuary (Fig. 7). In 1994 the Thames Estuary Cockle Fishery Regulating Order came into effect and covers 9 of the 13 identified cockle beds from the annual survey reports (Fig. 7) (Dyer and Bailey, 2018). The Thames estuary is characterised by cockle beds spanning large areas. Due to the difficulty in accessing these, the distance from the shore and their off-shore nature, the fishery allows for the collection of cockles via mechanical dredging on board fishing vessels. The order restricts fishing to 14 vessels and these beds are monitored and closed once stock levels drop below set limits. The fishery also supports hand gathering, mainly on the intertidal flats along the Essex coastline (mainly within the regulatory order). Mass mortalities in the Thames estuary are rare and it is not considered that this fishery suffers from atypical mortality as observed from the Burry Inlet and the Wash.

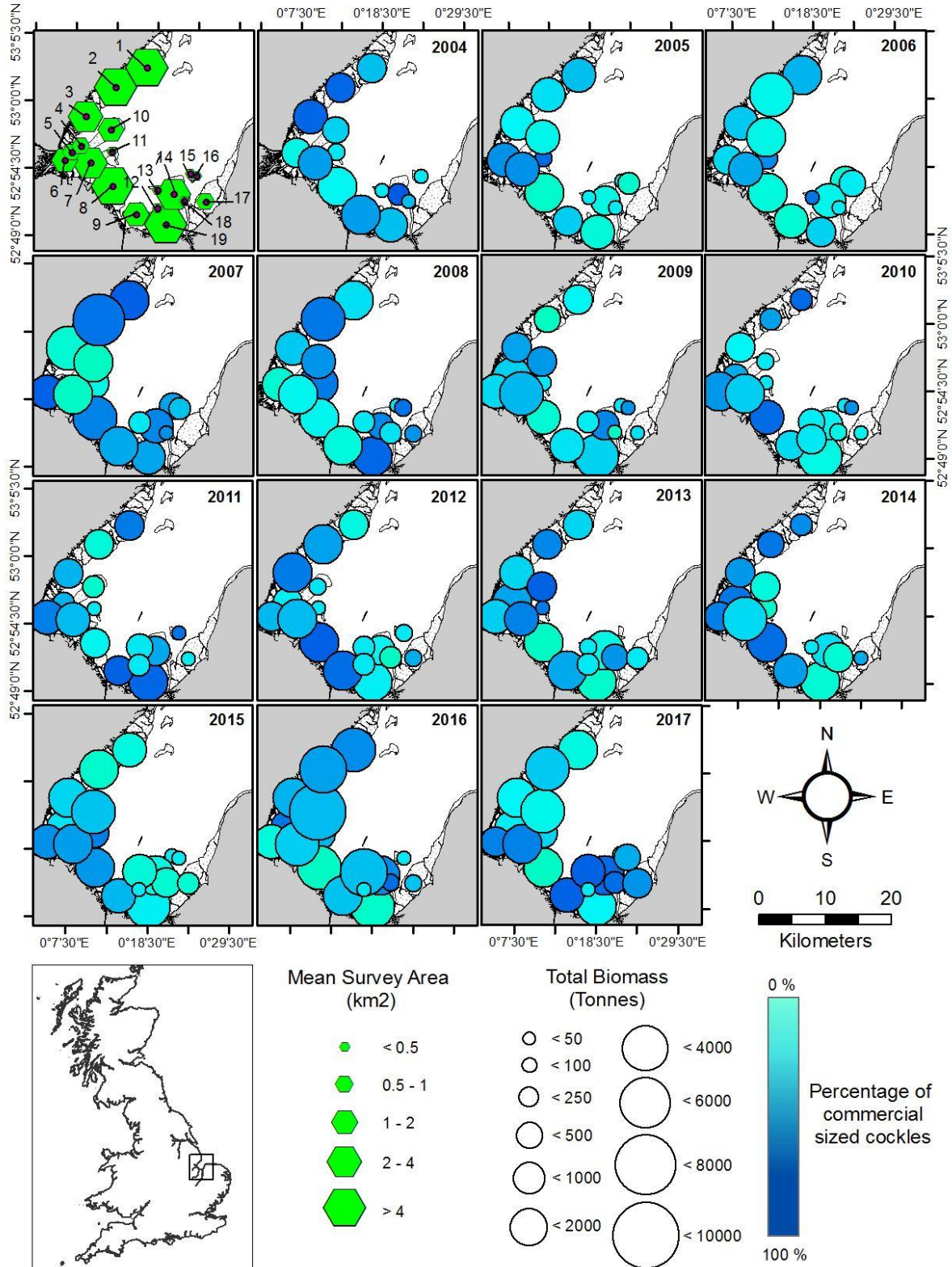
## Chapter 2



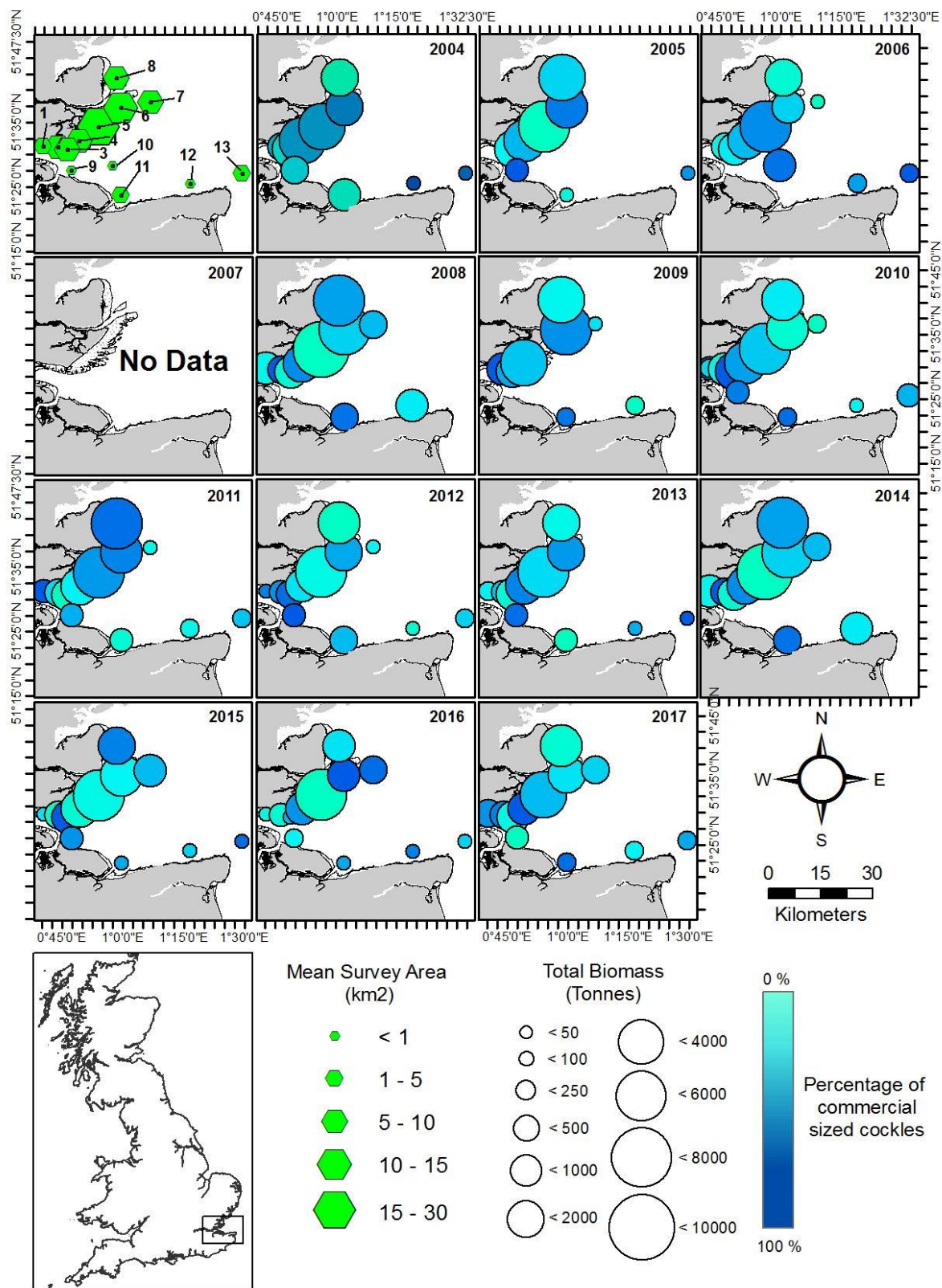
**Figure 4.** Changes in total biomass of *Cerastoderma edule* from the Dee Estuary annual spring survey results from between 2004 – 2017. Mean survey area for all years (green hexagons) (approximate location of beds) for the *Cerastoderma edule* beds: 1) Talacre, 2) West Bar, 3) Mostyn, 4) Salisbury, 5) South Salisbury, 6) South Salisbury/Number 3 Buoy combined (2013 only), 7) Number 3 Buoy, 8) The Marsh, 9) Thurstaton, 10) Caldy, 11) West Kirby, 12) Mostyn Deep & 13) Salisbury Middle. Estimated total biomass per year represented by circle size and colour gradient showing the percentage of commercial size cockles within the bed (2004 – 2010 > 25mm shell length; 2011 – 2017 > 20 mm shell length). Source of data: Natural Resources Wales.



**Figure 5.** Changes in total biomass of *Cerastoderma edule* found from the Burry Inlet annual spring survey results from between 2004 – 2017. Mean survey area for all years (green hexagons - approximate location of beds): 1) Pwll, 2) North Shore, 3) Middle Bank, 4) Butts, 5) Ochwr Draw, 6) South Shore & 7) Cheriton. Estimated total biomass per year represented by circle size and colour gradient showing the percentage of commercial size cockles within the bed (> 20mm shell length). Source of data: Natural Resources Wales.



**Figure 6.** Changes in total biomass of *Cerastoderma edule* from the Wash annual spring survey results from 2004 – 2017. Mean survey area for all years (green hexagons - approximate location of beds): 1) Friskney, 2) Wrangle, 3) Butterwick, 4) Black Bouy, 5) Herring Hill, 6) Herring Hill/Black Buoy, 7) Maretail, 8) Holbach, 9) IWMK, 10) Roger/Toft, 11) Gat, 12) Whiting Shoal, 13) Thief, 14) Daseley's, 15) Black Guard, 16) Styleman's, 17) Peter Black, 18) Pandora & 19) Breast. Estimated total biomass per year represented by circle size and colour gradient showing the percentage of commercial size cockles within the bed (> 16mm shell width). Source of data: Eastern Inshore Fisheries and Conservation Authority.



**Figure 7.** Changes in total biomass of *Cerastoderma edule* from the Thames Estuary annual spring survey results from 2004 – 2017. Mean survey area for all years (green hexagons - approximate location of beds): inside regulatory order: 1) Marsh End and Chapman Sands, 2) East of pier, 3) West of Shoebury boom, 4) East of Shoebury boom, 5) Maplin, 6) North Maplin and Foulness sand, 7) Cast Burrow and Maplin Spit., 9) West Cant and Scrapsgate 10) East Cant, Middle and Red Sand; outside regulatory order: 8) Buxey Ray and Dengie Sand, 11) Leysdown and ham, 12) South Margate Sands & 13) South Kent Coast to Dungeness. Estimated total biomass per year represented by circle size and colour gradient showing the percentage of commercial size cockles within the bed (>16 mm shell width). Data taken from annual survey reports. Source of data: Kent and Essex Inshore Fisheries and Conservation Authority.



## 2.4 Summary

From the data provide by the local authorities who manage each of the cockle fisheries, there are wide variations in the total area fished and in the biomass each beds can support. On the east coast of the UK, the Wash and Thames estuary can be characterised as large-scale fisheries, containing many cockle beds spread over a large area. The total biomass (adults and juveniles) at each bed is high (Fig. 6 and 7) however, the biomass of adult stock per km<sup>2</sup> is less than the fisheries on the west coast of the UK, suggesting that overall, densities are generally less (Fig. 3). The large areas covered by both the Wash and Thames estuary may be key in providing protection against natural environmental pressures on the stocks and help to support a highly productive fishery. The lower minimum landing sizes in the east from the west (16 mm compared to 19 and 20 mm, Table 1) also supports the view that the fisheries on this coast are large enough to cope with fishing cockles of this smaller size without having a negative impact on the stocks.

On the west coast, the Burry Inlet has suffered periodic mortality to cockles over 14 mm in size and has forced closures of the fishery. Adult biomass makes up only a small proportion of the total biomass (Fig. 3), but recruitment is stable, indicating that cockles found the inlet can successfully spawn prior to early induced mortality. The Dee estuary has shown good recovery in recent years from periods of poor recruitment (Fig. 4). The total area fished is the smallest among the four fisheries, however the total biomass per km<sup>2</sup> is the highest and made up of mostly commercial sized cockles.

Long term sustainability of the cockle fisheries is reliant on good management practises to maintain stocks at a level that meets the ecological and commercial demands. Allowing for the harvesting of adult cockles for commercial purposes must ensure that enough biomass is present after fishing for the wading bird populations. It must also ensure that enough spawning stock is left in the cockle bed for future recruitment. Finally, the management must be adaptable to mitigate sudden loss of stock from atypical mortality events.

## 2.5 References

- Beukema, J.J. and Dekker, R., 2005. Decline of recruitment success in cockles and other bivalves in the Wadden Sea: possible role of climate change, predation on postlarvae and fisheries. *Marine ecology progress series*, 287, pp.149-167.
- Bolaños, R. and Souza, A., 2010. Measuring hydrodynamics and sediment transport processes in the Dee Estuary. *Earth system science data*, 2(1), pp.157-165.
- Bowers, E.A., 1969. Cercaria *Bucephalopsis haimeana* (Lacaze-Duthiers, 1854) (Digenea: Bucephalidae) in the cockle, *Cardium edule* L. in South Wales. *Journal of natural history*, 3(3), pp.409-422.
- Burdon, D., Callaway, R., Elliott, M., Smith, T. and Wither, A., 2014. Mass mortalities in bivalve populations: A review of the edible cockle *Cerastoderma edule* (L.). *Estuarine, coastal and shelf science*, 150, pp.271-280.
- Camphuysen, C.J. et al., 2002. Mass mortality of common eiders (*Somateria mollissima*) in the Dutch Wadden Sea, winter 1999 / 2000: starvation in a commercially exploited wetland of international importance. *Biological conservation*, 106, pp.303–317.
- Callaway, R., Shinn, A.P., Grenfell, S.E., Bron, J.E., Burnell, G., Cook, E.J., Crumlish, M., Culloty, S., Davidson, K., Ellis, R.P. and Flynn, K.J., 2012. Review of climate change impacts on marine aquaculture in the UK and Ireland. *Aquatic Conservation: Marine and freshwater ecosystems*, 22(3), pp.389-421
- Callaway, R. et al., 2013. The riddle of the sands: how population dynamics explains causes of high bivalve mortality. *Journal of applied ecology*, 50(4), pp.1050–1059.
- Coscia, I. et al., 2012. Modelled larval dispersal and measured gene flow: seascape genetics of the common cockle *Cerastoderma edule* in the southern Irish Sea. *Conservation genetics*, 14, pp.451–466.
- Dare, P.J. et al., 2004. Historical and current status of cockle and mussel stocks in The Wash.
- Donadi, S., van der Zee, E.M., van der Heide, T., Weerman, E.J., Piersma, T., van de Koppel, J., Olf, H., Bartelds, M., van Gerwen, I. and Eriksson, B.K., 2014. The bivalve loop: intra-specific facilitation in burrowing cockles through habitat modification. *Journal of experimental marine biology and ecology*, 461, pp.44-52
- Ducrotoy, J.P., Rybarczyk, H., Souprayen, J., Bachelet, G., Beukema, J.J., Desprez, M., Dörjes, J., Essink, K., Guillou, J., Michaelis, H. and Sylvand, B., 1991. A comparison of the population dynamics of the cockle (*Cerastoderma edule*, L.) in north-western Europe. *Estuaries and coasts: spatial and temporal intercomparisons*, pp.173-184.
- Dyer, R. and Bailey, D. (2018). Thames Estuary Cockle Survey Report 2017. Kent and Essex Inshore Fisheries and Conservation Authority. pp. 44
- Elliott, M. and Holden, J., 2017. UK Sea fisheries annual statistics. Marine Management Organisation, Available at: [https://assets.publishing.service.gov.uk/government/uploads/system/uploads/attachment\\_data/file/742793/UK\\_Sea\\_Fisheries\\_Statistics\\_2017.pdf](https://assets.publishing.service.gov.uk/government/uploads/system/uploads/attachment_data/file/742793/UK_Sea_Fisheries_Statistics_2017.pdf)
- Hancock, D.A. and Urqhart, A.E., 1965. The determination of natural mortality and its cause in an exploited population of cockles (*Cardium edule* L.) *Fishery investigations series II XXIV* (2).
- Longshaw, M. & Malham, S.K., 2012. A review of the infectious agents, parasites, pathogens and commensals of European cockles (*Cerastoderma edule* and *C. glaucum*). *Journal of the marine biological association of the United Kingdom*, 93(01), pp.227–247.
- Longshaw, M., 2015. Unusual cockle mortalities in the Burry Inlet, South Wales. *Marine Science*. Available at: <https://marinescience.blog.gov.uk/2015/08/14/unusual-cockle-mortalities-burry-inlet/>.
- Malham, S.K., Hutchinson, T.H. & Longshaw, M., 2012. A review of the biology of European cockles (*Cerastoderma* spp.). *Journal of the marine biological association of the United Kingdom*, 92(07), pp.1563–1577.

## Chapter 2

- Moore, J.J. (2011). Survey of cockle stocks in the Burry Inlet, June 2011. A report to the Environment Agency Wales from Coastal Assessment, Liaison & Monitoring, Cosheston, Pembrokeshire. pp. 19
- Morgan, E., O' Riordan, R.M. & Culloty, S.C., 2013. Climate change impacts on potential recruitment in an ecosystem engineer. *Ecology and evolution*, 3(3), pp.581–94.
- Natural England, 2010. The Dee Estuary European Marine Site. Natural England & the Countryside Council for Wales' advice given under Regulation 33(2) of the Conservation (Natural Habitats &c.) Regulations 1994, pp.259
- Orton, J.H., 1933. Summer mortality of cockles on some Lancashire and Cheshire Dee beds in 1933. *Nature*, 132(3330), p.314.
- Pontee, N., Allen, E., Pye, K., and Parsons, A., 2013. Dee Estuary. North West Estuaries Processes Reports, Halcrow Group, pp.63. Available at: [https://www.liverpool.ac.uk/~cmi/dee/Dee\\_rep2013.pdf](https://www.liverpool.ac.uk/~cmi/dee/Dee_rep2013.pdf)
- Wilson, A. 2009. Shellfish Industry Development Strategy. A 'Best-Practice' Guide of Sea Fisheries Committee, Shellfish Byelaws. SEAFISH report, pp.48
- Woolmer, A. P. 2010. Provisional Review and Advice of Cockle Management in the Burry Inlet. Report to the Environment Agency from the Shellfish Association of Great Britain (SAGB). [http://www.shellfish.org.uk/files/25665Cockle\\_Report.pdf](http://www.shellfish.org.uk/files/25665Cockle_Report.pdf)
- Woolmer, A., Fitzgerald, A., Woo, J., and Wooton, E., 2013. Atypical Cockle Mortality in England and Wales. *Galacia-Marine*, pp.54. Available at: <https://www.kentandessex-ifca.gov.uk/wp-content/uploads/2015/07/report-of-EU-and-UK-cockle-mortality.pdf>.
- Young, E. et al., 1998. A modelling study of environmental influences on bivalve settlement in The Wash, England. *Marine ecology progress series*, 172, pp.197–214.

## **Environmental unknowns in the growth and development of *Cerastoderma edule* (L.) larvae from North Wales**

### **3. Abstract**

The health of a cockle fishery is partly influenced by environmental anomalies that can result in heavy commercial losses due to the failure of the stock. A key factor affecting cockle populations each year, is the effect of environmental parameters on the survival of the pelagic larval phase of the juvenile cockle. The larval phase generally lasts for about three weeks in the plankton before settlement with reported spawning times late spring and early summer. As the larvae and adults have separate planktonic and bottom dwelling phases it is important to understand the processes affecting this pelagic stage of their life. This research investigates the links between environmental stressors on the larvae's development and survival prior to metamorphoses and settlement taking place. Adult cockles collected from two locations in North Wales (Dee estuary & Traeth Melynog) were induced to spawn in the laboratory and the larvae generated were reared under three temperature and two different levels of micro-algae for a period of three weeks. Shell length measurements taken at intervals during this time show a positive relationship between rate of growth and temperature. Larvae grew faster and took less time to reach metamorphoses when reared at 15 and 20 °C compared to those at 10°C. Metamorphoses was not observed at 10 °C for the duration of the experiments. Mortality rates were found to be higher with elevated temperatures, indicating the larvae's sensitivity to increased temperatures. Larval growth was not found to be influenced by the levels of food within treatments, however differences in shell length were observed between sites suggesting that larvae generated from broodstock collected from Traeth Melynog, grew faster, reached metamorphoses earlier and survived for longer compared to larvae generated from broodstock from the Dee estuary. The results of this study advance our understanding of the potential effects of altered temperature and food conditions on the growth and survival during the larval pelagic stage of the life cycle of the cockle and are relevant in a changing climate.

#### **3.1.1 Introduction**

*Cerastoderma edule* (Linnaeus 1758; Phylum: Mollusca; Class: Bivalvia) is a gonochoristic intertidal bivalve that reproduces by synchronous broadcast spawning events, which in the waters off Europe take place during the spring and summer months (Hancock & Franklin 1972; Seed & Brown 1977). Water temperature and food availability are known to

stimulate reproduction, and fertilisation of the gametes takes place externally in the water column, with the eggs developing into planktonic free swimming larvae (Creek 1960; Ruppert et al., 2004). These larvae play a vital role in sustaining the adult populations (Thorson, 1950). Commercial fisheries targeting adult *C. edule* rely on healthy stocks, which themselves provide an important ecosystem service to wading birds and epibenthic predators as food, for nutrient recycling and by promoting sediment stability (Jensen and Jensen, 1985; Norris et al., 1998; Cesar, 2004; Goss-Custard et al., 2004; West et al., 2007; Eriksson et al., 2010; Genelt-Yanovskiy et al., 2010; Malham et al., 2012; Whitton et al., 2013; Burdon et al., 2014). Recruitment to a population is a multi-stage process and is determined by many biological (biotic) and physical (abiotic) mechanisms that influence the larvae's development, survival and physiology. Abiotic factors which have been shown to affect marine bivalve larvae include, but are not limited to: seawater temperature, salinity and water quality (Davis and Calabrese, 1964; Bayne, 1965; Brenko and Calabrese, 1969; Kingston, 1974; Sprung, 1984; Robert et al., 1988; His et al., 1989; Pechenik et al., 1990; Philippart et al., 2003; Verween and Degraer, 2007; Talmage and Gobler, 2011; Waldbusser et al., 2015), whilst the biotic factors include food availability, food quality, predation, larviphagy, pathogenesis, larval density and competition (Tubiash et al., 1965; His et al., 1989; Osmen et al., 1989; Pechenik et al., 1990; Andre & Rosenberg, 1991; Fotel et al., 1999; Phillips, 2002;; Troost et al., 2008; Pronker et al., 2015).

Synchronising spawning events to coincide with the spring phytoplankton bloom, commonly seen for many intertidal marine bivalve species, benefits recruitment to a population. It provides an abundance of food that supports large numbers of individual larvae, which in turn reduces the pressure of competition and increases their survival chance (Platt et al., 2003, Philippart et al., 2003). Driven by the photoperiodic change in daylight hours, light intensity and nutrient availability, the occurrence of these phytoplankton blooms is at a relatively predictable point in time, although can display slight year to year variation (Cadée, 1986; Philippart et al., 2000; Philippart et al., 2003; Edwards and Richardson, 2004). In years when the environmental conditions lead to a separation between the arrival of larvae in the water column and the phytoplankton they feed upon, then the development and survival of the larvae can be negatively affected (Thorson, 1950; Cushing, 1975; Cushing, 1990; Ducrottoy et al., 1991). Between 1958 and 2002 the arrival of pelagic larvae in the North Sea has been shown to follow a long term climatic driven pattern of elevated seawater temperatures occurring earlier in the spawning season (Edwards and Richardson, 2004). This has subsequently created

a mismatch (Cushing, 1975) between trophic levels as diatoms, a vital food source to the meroplankton (organisms which are benthic or nektonic as adults), have not responded in the same way to this temperature shift (Edwards and Richardson, 2004). Ultimately this mismatch can lead to starvation and increased levels of mortality of the larvae (Cushing, 1990).

Research on the development of bivalve larvae has predominantly targeted species that are of interest to commercial scale aquaculture production. This includes, but is not limited to, species of oysters and mussels such as *Crassostrea gigas* (Pacific oyster), *Ostrea edule* (European flat oyster) (Gouletquer, 2004) and *Mytilus edulis* (Blue mussel) (Gosling, 1992; Garen et al., 2004; Pronker et al., 2008). Over years of breeding programs, shellfish hatcheries have developed methods which optimise conditions to maximise growth, development and survival (Helm, 2004; Shumway and Parsons, 2011; Lee et al., 2016). To reach a commercial size, hatchery produced juveniles are contained on or near the seabed for grow-out in their natural environment. The techniques used involve attaching individuals to artificial structures, using nets or crates as holding pens, or seeding existing beds (Helm, 2004; Shumway and Parsons, 2011). These methods suit species that attach themselves to the substratum or each other via byssus thread (Gosling, 2003). Currently, cockles are not suited to this form of aquaculture and no hatchery cultivation has been developed at an industrial scale, a possible explanation as to why the larval stages of cockles has not received the same amount of interest. Sediment is required for burrowing and they can quickly deteriorate when exposed to air out of the sediment for extended periods of time (Boyden, 1972; pers. obs), an obstacle that any hatchery will have to overcome. Containing the cockles on the seabed in their natural environment also poses its own challenges as they are mobile animals that can move across the tidal flats (Flach, 1996) and are easily displaced by currents and tides. The likely purpose for developing a hatchery programme for *C. edule* would be to seed existing stocks with spat to mitigate the effect of poor recruitment years (Dijkema, 1992; Beukama and Dekker, 2005) and/or large-scale mortality events to the adult populations (Malham et al., 2012; Woolmer et al., 2013; Burdon et al., 2014). This form of bottom culture is more commonly seen for *Mytilus edulis* (Garen et al., 2004; Dolmer et al., 2012) and other species of clams (Tiensongrasmee and Pontjoprawiro, 1988), but they rely on naturally harvested seed to be removed from settlement areas and transferred onto managed beds. Although *C. edule* is potentially viable for aquaculture (Pronker et al., 2015), to date no evidence can be found of this being attempted.

For the past decade, the average global temperature has surpassed any other decadal period since records began (IPCC, 2014). Due to the relationship between seawater temperature

and spawning period, climate predictions suggest we could expect to find years when larvae and their food source become off-set from one-another. The need to understand the larvae's response to the environmental drivers may become more important to the shellfish industry and the sustainability of cockle stocks. One concern is the knock-on ecological effect that loss of stock can have. Poor recruitment one-year can have a devastating effect on the macrobenthos community and organisms higher up the trophic levels which rely on new recruits as a major food source (Camphuysen et al., 2002; Goss-Custard et al., 2004; Cesar, 2009). Identifying the processes responsible for their successful development and survival is a step towards predicting outcomes based on current and future environmental conditions.

### 3.1.2 Aims and Hypotheses

Knowledge on how *C. edule* larvae develop in their natural environment is relatively poor. Creek (1960) described in detail the stages of development for *C. edule* larvae cultured in 15°C seawater and subsequent studies have used this as a baseline for their own research. Due to the difficulty in sampling naturally occurring larvae, research has had to rely on using methods adopted from larval hatcheries to regenerate larvae. Studies on *C. edule* larvae have concentrated on measuring shell growth and survival at different temperatures and different salinity concentrations whilst feeding the larvae a single species of phytoplankton at a single density (Creek, 1960; Boyden, 1971; Kingston, 1974). Shell growth in relation to food quantity and variety has also been measured but at a single temperature (Pronker et al., 2015).

The main objective of this study is to investigate how growth, development and survival of *C. edule* larvae respond to different environmental conditions during the pelagic phase of their life-cycle. By generating larvae in the laboratory from broodstock collected from the wild, their response to a combination of different seawater temperatures and food availability scenarios can be assessed. The experiments use temperatures similar to those experienced at the beginning, middle and end of a “typical” spawning season that occur in waters off northern Europe. By using a mixture of multiple algal species in the diet, the food availability addresses periods of high and low phytoplankton concentrations to simulate match or mismatch scenarios. It is hypothesised that during their pelagic phase, larvae of *C. edule* will grow and develop faster, reaching metamorphoses earlier as temperature and the availability of food (e.g. during annual phytoplankton blooms) are increased (His et al., 1989). This study also describes a successful spawning procedure that was developed for generating and capturing larvae for the laboratory experiments.

## 3.2 Materials and Methods

### 3.2.1 Broodstock collection and larval culture

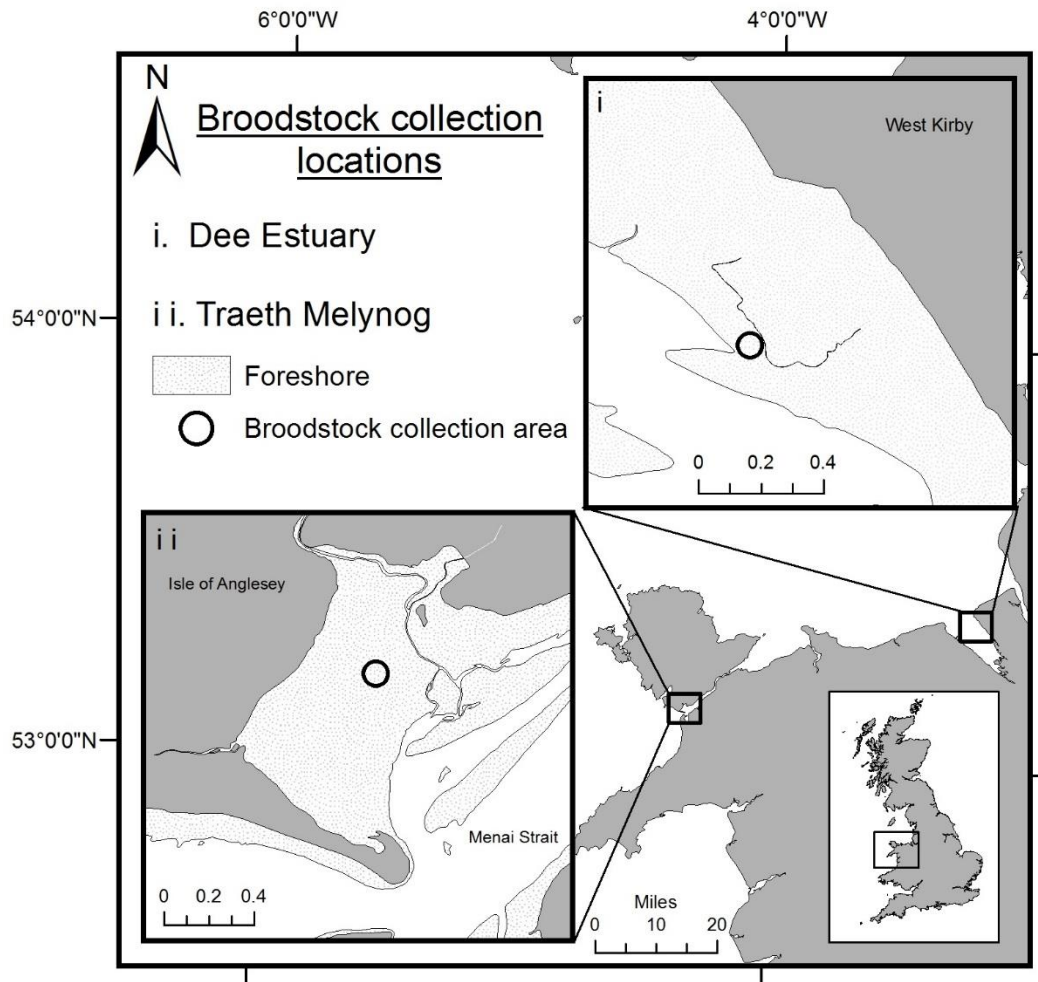
Adult cockles collected from beds in North Wales were used as broodstock for both larval experiments. The first experiment used cockles from West Kirby in the Dee Estuary (DEE) whereas the subsequent experiment used cockles from Traeth Melynog (TM) (Table 1, Fig. 1). Space limitations prevented simultaneous spawning from both locations although each experiment coincided with the general spawning season which occurs between the months April and August (Lebour 1938, Boyden 1971, Hancock and Franklin, 1972, Seed and Brown 1977).

Cockles were transported to the aquarium on ice then placed in 50 L holding tanks at densities of 50 individuals per tank equivalent to  $<200 \text{ m}^{-2}$  until used for spawning. A continuous supply of unfiltered seawater taken directly from the Menai Strait flowed into a sump tank and subsequently pumped (Aqua-Medic Ocean Runner 2500) to each holding tank at a rate of  $1 \text{ L min}^{-1}$ . This ensured that the water in the holding tanks was replaced on an hourly basis. Water temperature was maintained at  $13^\circ\text{C}$  to mimic the temperature experienced in the natural environment and to prevent premature spawning in the holding tanks.

**Table 1.** Location and spawning information of the *Cerastoderma edule* broodstock used in the larval culture experiments.

Collection date	Location	GPS (lat/long $\pm 10\text{m}$ )	Spawned
19 <sup>th</sup> May 2015	West Kirby, Dee Estuary	53.35641N 03.18817W	20 <sup>th</sup> May 2015
9 <sup>th</sup> July 2015	Traeth Melynog, Isle of Anglesey	53.140051N 04.33142W	10 <sup>th</sup> July 2015





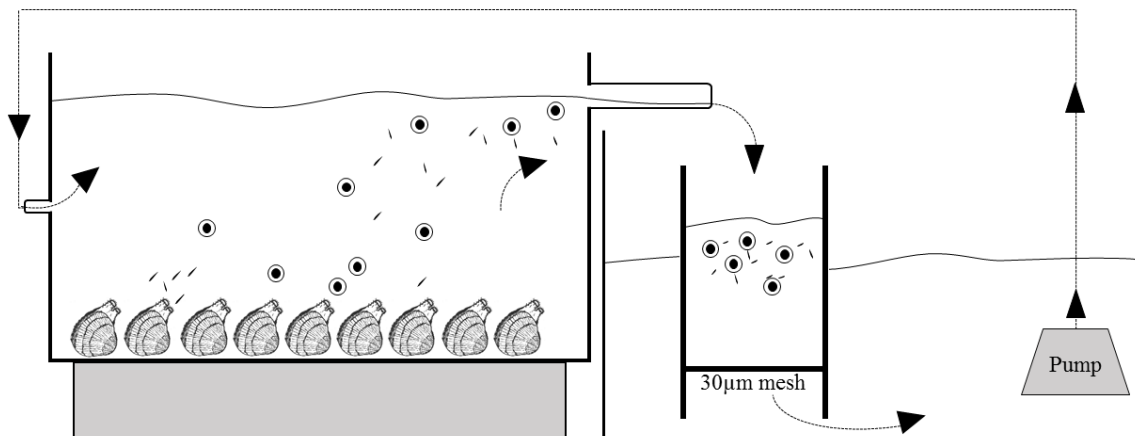
**Figure 1.** Map showing the location of each cockle bed in North Wales used for the collection of adult spawning stock.

### 3.2.2. Spawning

All seawater used in the larval cultures passed through a 0.2  $\mu\text{m}$  filter and was UV-sterilised to limit bacterial concentrations prior to use. Salinity averaged around 34‰ ( $\pm 0.5$ ) for the duration of the two experiments.

Prior to spawning, 200 adult cockles (>20 mm shell length; SL) were removed from the holding tanks then washed and scrubbed with fresh seawater to remove debris. These were then placed in a spawning tank containing aerated seawater at a temperature of 23°C, 10°C higher than the temperature of the holding tanks (Fig. 2) (Pronker et al., 2015). The sudden temperature change was used to induce the release of gametes and is based on the thermal cycling method (Helm, 2004).

An adjacent tank containing a cylindrical section of pipe ( $\text{\O}110\text{ mm}$ ) fitted with a  $30\text{ }\mu\text{m}$  nylon mesh captured the eggs as they were passed out of the spawning tank after being released from the female cockles. Separation between the released gametes and the adult cockles was achieved and limited any ingestion due to the high stocking density (Andre et al., 1991). An aquarium pump (EHEIM, Compact 600) circulated the seawater within the system and sperm was allowed to continuously circulate in the system as it was deemed too small to get damaged by the pumps impeller or cause blockages. When the mesh collecting the eggs blocked, it was moved to the side of the tank and replaced with another identical section of pipe and mesh. The adult cockles remained in the spawning tank for 24 hours. Seawater continued to circulate between the tanks to ensure fertilisation of the eggs, following the methodology developed by Kingston (1974) and Pronker et al., (2015).



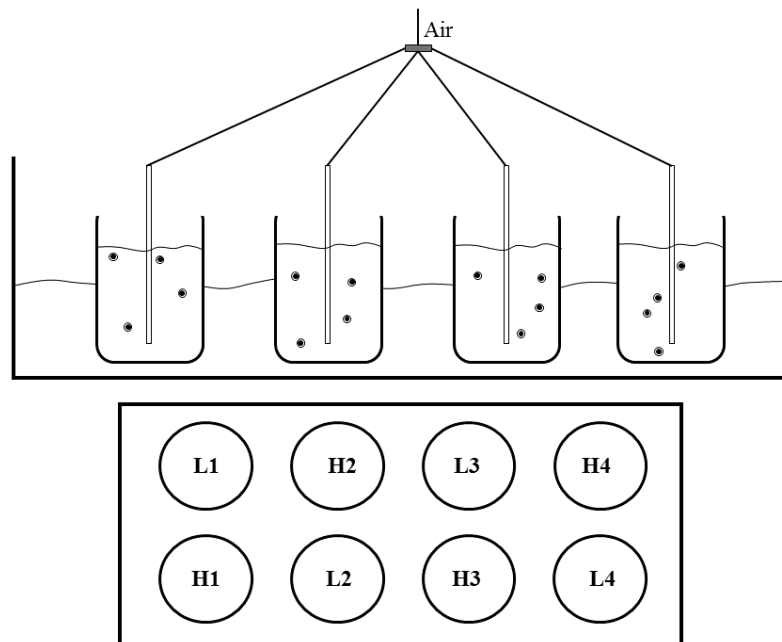
**Figure 2:** Re-circulatory system used during the spawning process of adult *Cerastoderma edule* to collect and separate the eggs and assist fertilisation. Spawning tank (left) and holding tank (right). Arrows and dotted lines indicate the flow of seawater.

The following day, named “day post fertilisation (DPF) 0”, all eggs collected in the mesh traps were rinsed with and decanted through a series of meshes of reducing aperture size (smallest  $140\text{ }\mu\text{m}$ ) into a plastic beaker containing UV-sterilised seawater, thus removing unwanted materials present in the water. The volume of seawater was brought up to 1L and then gently homogenised using a small plankton mixer. The total number of eggs present in the mixture was calculated by taking the average of three 1 ml sub-samples. Each sub-sample was

placed on a Sedgewick counting rafter and the eggs counted. Images of the eggs (and subsequent larvae) were captured using a Meiji microscope with camera (Lumenera, INFINITY 3) running Image Pro Premier 9.1 software (Media Cybernetics). The egg mixture was equally divided and transferred into 24 identical 1L cylindrical plastic beakers containing 800ml of seawater.

### 3.2.3 Experimental set-up

The two identical experiments consisted of two treatments: 1) water temperature and 2) food concentration. Eight beakers of larvae were reared at 10, 15 and 20°C and 4 beakers within each temperature treatment were allocated to one of two feeding treatments (Fig. 3). Half of the beakers received a mixture of micro-algae at  $100 \text{ cells } \mu\text{l}^{-1}$  (High). The other half fed the other half the same mixture of micro-algae at  $25 \text{ cell } \mu\text{l}^{-1}$  (Low), 25% of the food density in the High treatment (Table 2).



**Figure 3:** Water baths and culture beakers used for rearing *Cerastoderma edule* larvae in each temperature treatment (top). Layout of the replicate beakers and their assigned feed within each water bath (bottom). High (H) =  $100 \text{ cells} \cdot \mu\text{l}^{-1}$ , Low (L) =  $25 \text{ cells} \cdot \mu\text{l}^{-1}$ .

Micro-algae were first introduced to each replicate beaker on the 2<sup>nd</sup> day post-fertilisation. Water baths were used to control water temperatures for all treatments by use of an aquarium water chiller (Aqua-medic, Titan 250) for the 10°C treatment and two 150W

aquarium heaters (Aquael, Neoheater 150) for the 20°C treatment. Ambient room temperature kept the 15°C treatment consistent (Fig. 4). Coefficients of variation ( $100 \times \text{SD}/\text{mean}$ ) for each treatment's water temperature varied between 0.8 and 1.5% over the duration of each experiment (Table 2).

**Table 2.** Treatment allocation for the larval cultures and the variation in temperature of the water baths during each experiment.. High = 100 cells. $\mu\text{l}^{-1}$ , Low = 25 cells. $\mu\text{l}^{-1}$ \*Note T10H & T10L.  $n = 3$  from DPF 10 onwards due to sampling error.

Experiment	Temperature (°C)	Temperature Range of water baths (°C, $\pm 1$ SD)		Treatment Code	Number of replicate beakers ( $n$ )
		Food Concentration			
Dee	10	High		D10H	4
		Low		D10L	4
	15	High		D15H	4
		Low		D15L	4
	20	High		D20H	4
		Low		D20L	4
TM	10	High		T10H	4 (3)
		Low		T10L	4 (3)
	15	High		T15H	4
		Low		T15L	4
	20	High		T20H	4
		Low		T20L	4

Aeration to each replicate beaker passed through a 0.3  $\mu\text{m}$  particle filter (Whatman, Hepa-Vent) prior to being supplied via stiff plastic tubes. This assisted in keeping the water mixed and larvae in suspension. All larval treatments were subjected to 24 hours continuous light.

### 3.2.4 Feeding

Five species of micro-algae were used as feed in each experiment and were selected based upon cell size. These consisted of the flagellates: *Diacronema lutheri* (CCAP931/1); *Isochrysis galbana* (CCAP927/1); *Rhinomonas reticulata* (CCAP995/2) and *Tetraselmis chui* (CCAP8/6) and the diatom *Nannochloropsis oculata* (CCAP849/1). Each species was semi-continuously cultured in 20L volume round bottom flasks supplemented with seawater enriched with Walne's medium (Walne 1970). Light conditions and aeration remained constant

with room temperature averaging between 22 - 24°C. Prior to feeding, cell counts for each algal species were made using a Fuchs-Rosenthal haemocytometer. An equal cell ratio of 1:1:1:1:1 of the 5 species was used and provided a balanced and nutritional diet that was suitable for all stages of development.

### ***3.2.5 Larval rearing and image capture***

Each experiment lasted approximately 3 weeks and covered the planktonic phase of development. Metamorphosis is expected to take place after this time frame at a shell length size of around 270 µm when reared at 10 -15°C (Lebour 1938, Creek 1960). Every 2-3 days the larvae from each replicate were carefully filtered onto a 30µm nylon mesh and transferred to small pots for transportation to the microscope. Fresh seawater was gently added to make a 20ml volume larval solution. The added seawater was equal in temperature to each treatment thus limiting the shock placed on the larvae. A 1ml sub-sample was taken from the larval solution using a pipette and placed on a Sedgewick rafter. Estimates of survival, image capture and the recording of the stages of development were noted from the larvae alive in the sub-sample (Table 3). When the first sub-sample did not contain live larvae due to low densities, additional sub-samples were taken to capture those that may still have been present but not initially sampled. The survival estimates were based on the first sub-sample.

All larvae were gently rinsed back into their original beaker once images had been generated. During the time out of the water baths the water temperature in each beaker had acclimatised to the room temperature, which was approximately 20°C where image capturing took place. To minimise further stress on the larvae, each treatment beaker was filled with fresh seawater of that same temperature so that when placed back in the water baths they could gradually return back to the treatment temperature.

All items of equipment in contact with the larvae were cleaned during the time out of the system. These were washed with warm fresh water and a mild disinfectant (Starlab CHEMGENE (HLD<sub>4</sub>L), dilution 1:100). They were then rinsed thoroughly with hot water and left to air dry.

### Chapter 3

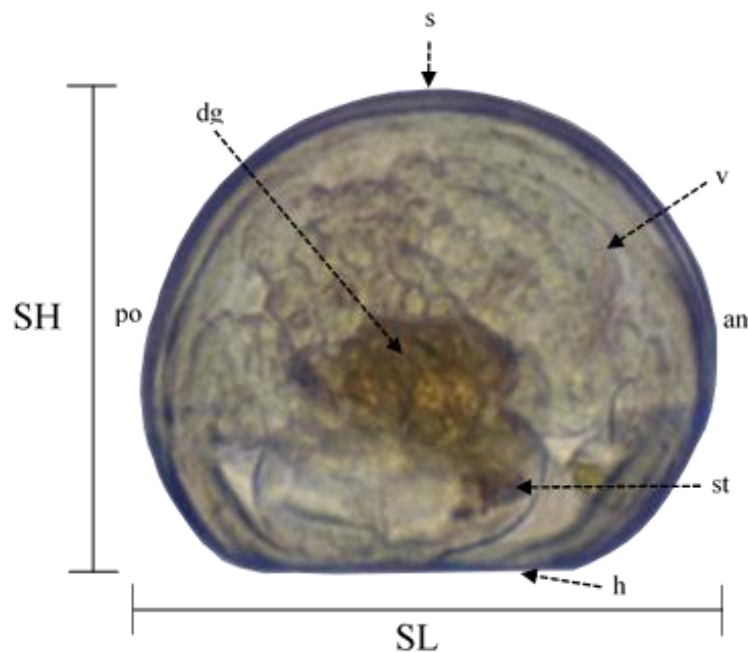
**Table 3.** Description of the developmental stages for *Cerastoderma edule* larvae. Images of the larval stages are shown in figure 5.

Developmental Stage	Description	Ref.
<b>Embryo</b>	Released ova measure approximately 70 µm in diameter. Embryos rapidly divide once fertilisation has been successful (a) and within hours polar bodies may be visible and the cells begin to undergo the first cleavage (b). Unequal division then follows (c-e) and, after a few hours, cilia form on the surface causing rotation within the gelatinous membrane (f). The gelatinous membrane provides protection to the developing gastrula and assists in fertilisation by preventing polyspermy whilst increasing the ova's surface area and the chance of contact with sperm.	Fig.5 a - f
<b>Trochophore</b>	Approximately 24 – 48 hr after initial fertilisation the trochophore has fully formed and if hatched from the gelatinous membrane, are free swimming and propelled by cilia (g-h). An apical tuft is present on the dorsal surface and by now the rudiments of the mouth, anus, digestive gland and stomach are in place. Towards the end of the trochophore stage, the shell gland begins to secrete the first shell called the prodissoconch I which is followed by rapid formation of the velum (i-j). By the end of this stage the larvae have paired D-shaped shell valves which are around 100µm in length and the digestive system is functioning (k-l).	Fig. 5 g-l
<b>Veliger</b>	During the veliger stage larvae are free swimming with a distinctive D-shaped shell and are categorised by the secretion of the second shell or prodissoconch II. Shell lengths range from 100 – 250 µm and this stage being the longest of all stages can last for a period of weeks dependent upon temperature. Larvae have a velum that is used for swimming and feeding and is retractable by visible retractor muscles between the two shell valves.	Fig. 5 m & n
<b>Pediveliger</b>	A transitional period between the veliger and fully metamorphosed cockles and is the last stage of the pelagic life. This larval stage displays both velum and foot and has the ability to either swim or crawl. The umbo is pronounced and the foot and gills grow rapidly prior to metamorphosing. Shell lengths range from 220 – 270 µm. The internal organs start to become more distinguished and the oesophagus, stomach, digestive gland and intestine are further distinguishable.	Fig. 5 o
<b>Metamorphosed</b>	Individuals metamorphose when a suitable substrate has been found and are within a size range of between 250 – 350 µm SL. At this point larvae will be approximately 3 – 4 weeks old. The prodissoconch II shell has ended and the dissoconch shell starts forming and a clear defining line is present on the shell surface. Shell shape resembles that of the adults and further shell secretions are ribbed. The cockles are now fully settled.	Fig. 5 p

(Jørgensen 1946, Creek 1960, Carriker 1961, Gosling 2003, Pronker et al., 2015)

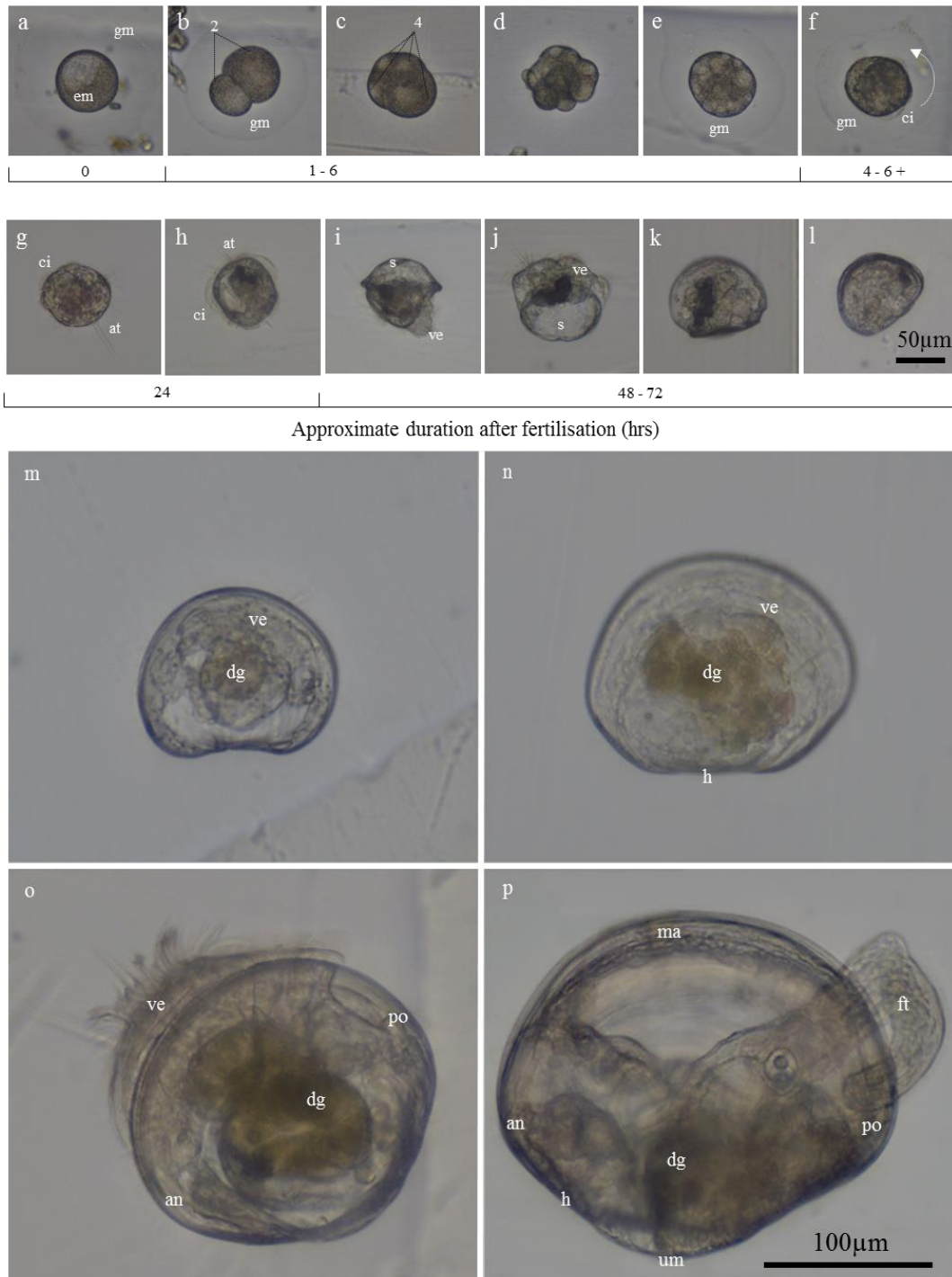
### 3.2.6 Larval measurements

A total of 1798 images were collected from the larvae. For each of these images, the same software was used to measure the horizontal distance between the anterior and posterior ends of the cockle's shell, referred to as shell length (SL) (Fig. 4). Measurements were only made for those larvae that had reached the veliger stage of development and were orientated correctly in the image. Images that did not capture the larvae in the correct orientation, or were out of focus, were discarded from the analysis. The stage of development for each individual was assigned based upon shell presence and shape (Table 3, Fig. 5). On the occasions when larvae were identified as having arrested during development (defined as alive but showing a decline in soft tissue mass) or had developed deformities in growth (e.g. irregular shell shape), they continued to be included in the measurements, as it was unknown how long survival would continue (Fig. 6 & 7).



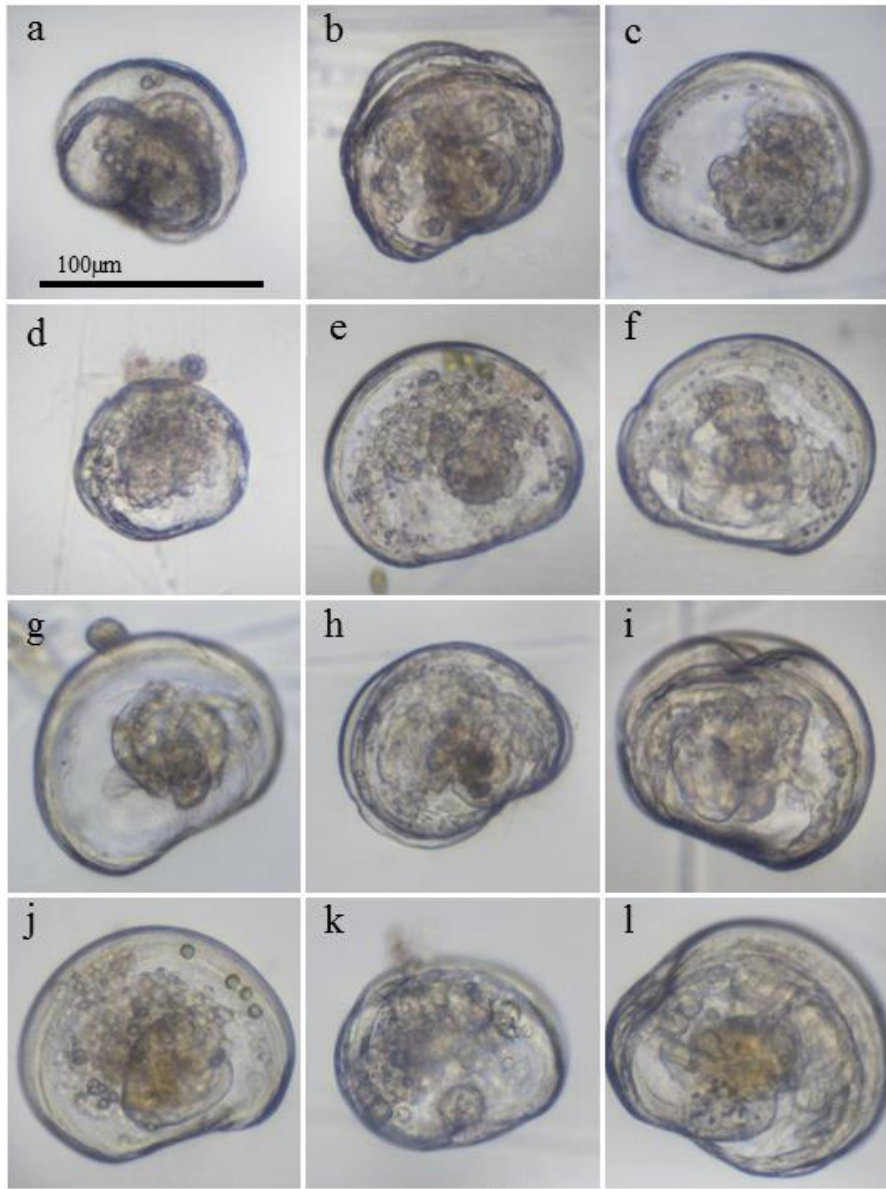
**Figure 4.** Example of a 10-day old veliger larvae ~ 120 $\mu$ m illustrating the shell length (SL) and shell height (SH) measurements taken from each individual. an = anterior end, dg = digestive gland, h = hinge, po = posterior end, s = shell, st = stomach and v = velum (retracted).

### Chapter 3

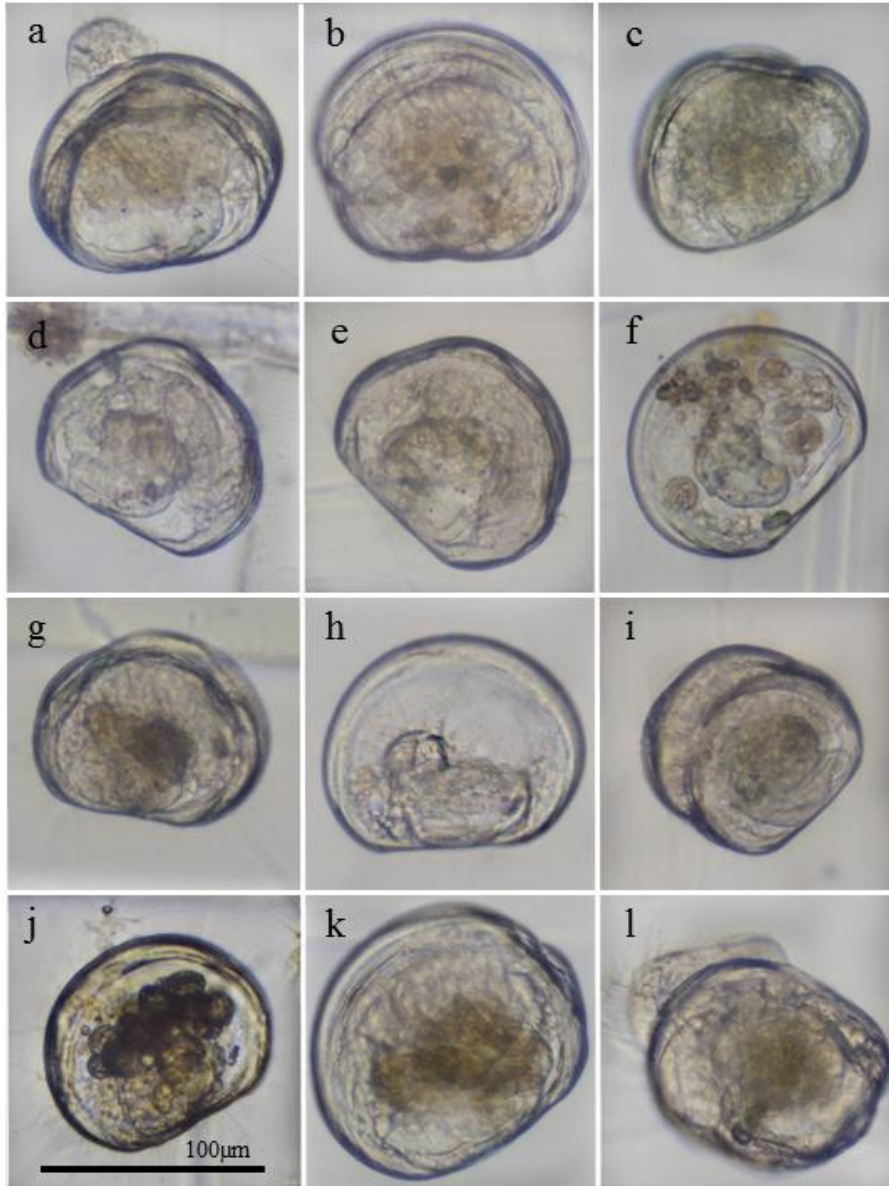


**Figure 5.** Developmental stages of *Cerastoderma edule* larvae from embryo to metamorphosed juvenile. a) fertilised embryo, b) first cleavage - 2 cell stage, c) 4 cell stage, d) multi-cell stage, e-f) late gastrula, g-h) early trochophore (hatched), i-k) late trochophore, l-m) early veliger, n) veliger (D-larvae), o) pediveliger and p) metamorphosed juvenile: an) anterior end, at) apical tuft, ci) cilia, dg) digestive gland, ft) foot, gm) gelatinous membrane, h) hinge, ma) mantle, po) posterior end, sI) prodissoconch I, sII) prodissoconch II, um) umbo and ve) velum. Arrow in (f) indicating direction of rotation.





**Figure 6.** Examples of veliger larvae from the Dee experiment that were observed during the sampling that display deformities to the shell or have a reduced internal tissue structure. 10H: a & b; 10L: c & d; 15H: e & f; 15L: g & h; 20H: i & j and 20L: k & l. Images b, f, h, i and l show deformations to the larval shell.



**Figure 7.** Examples of veliger larvae from the TM experiment that were observed during the sampling that display deformities to the shell or have a reduced internal tissue mass. 10H: a & b, 10L: c & d, 15H: e & f, 15L: g & h, 20H: i & j and 20L: k & l. Images a – e, g, i, k and l show deformations to the larval shell.

### 3.2.7 Statistical analyses

Two statistical tests were carried out to investigate the relationship between the shell length of the larvae (dependent variable) and the different treatments (6 levels) (independent variables). These consisted of: temperature (3 levels) and food concentration (2 levels). The first addressed the expectation that treatment has an effect on the growth of larvae by comparing the shell length of larvae generated from the Dee estuary and Traeth Melynog at two points in time, at the start (DPF 5) and towards the end (DPF 19). These time points were selected as they were consistent across the duration of both experiments. A two-way Analysis of Variance (ANOVA) was used to test the difference in variance between the treatment means, i.e. the difference in shell length as a result of the temperature and food concentration. The null hypothesis of ANOVA assumes that there is no difference between treatment means.

The ANOVA model is expressed as:

$$F = \frac{MST}{MSE}$$

$$MST = \frac{\sum_{i=1}^k \left( \frac{T_i^2}{n_i} \right) - G^2}{k - 1}$$

$$MSE = \frac{\sum_{i=1}^k \sum_{j=1}^{n_i} Y_{ij}^2 - \sum_{i=1}^k \left( \frac{T_i^2}{n_i} \right)}{n - k}$$

Where:

- $F$  = variance ratio
- $MST$  = mean sum of squares due to treatments (between groups)
- $MSE$  = mean sum of squares due to error (within groups, residual mean square)
- $Y_{ij}$  = an observation
- $T_i$  = group total
- $G$  = total of all observations
- $n_i$  = number in group  $i$
- $i$  = total number of observations

Following on from a significant ANOVA result, a Tukey's HSD (honestly significant differences) post hoc analysis was then conducted to identify what treatment levels differ from one another. The null hypothesis of the Tukey's test assumes that the means from all groups originate from the same population and that observed variation in the means between two independent variables, means they are significantly different from each other.

The Tukey's HSD formula is expressed as:

$$HSD = \frac{M_i - M_j}{\sqrt{\frac{MS_w}{n_h}}}$$

Where:  $M_i - M_j$  = Difference between two means, with  $M_i$  being larger

$MS_w$  = Mean square within

$n$  = number in the treatment  $h$

To assess the effect of the different treatments on larval growth in relation to time, i.e. the rate at which the larvae grow, an analysis of covariance (ANCOVA) multiple regression model was run using the mean shell length value recorded on each DPF. The model used time as the continuous variable (covariate) and all the independent variables to test the individual effect or interaction of multiple independent variables on the shell length of the larvae. These included site (2 levels), temperature (3 levels) and food concentration (2 levels). Two approaches were conducted by fitting linear and a polynomial regression line through the data to explain any variation in growth rates. The linear approach ( $L$ ) assumed that larval growth is continuous over time and made no change to DPF. The non-linear ( $Q$ ) (polynomial) approach applied a quadratic transformation to DPF and assumes that larval growth increases with increasing individual size. By incorporating both relationships ( $L$  &  $Q$ ) into the model, but excluding the interaction between the two, ensured that the best possible fit for the model was achieved. The null hypothesis of an ANCOVA is it assumed that there is a linear relationship between shell length and time.

The ANCOVA model is expressed as:

$$y_{ij} = \mu + \tau_i + B(x_{ij} - \bar{x}) + \epsilon_{ij}$$

Where:  $y_{ij}$  = Dependant variable at the  $j$ th observation in group  $i$

$\mu$  = the overall mean

$\bar{x}$  = global mean for covariate  $x$

$x_{ij}$  =  $j$ th observation of the covariate in the  $i$ th group

$\tau_i$  = effect of  $i$ th level of the independent variables

$B$  = slope of the line

$\epsilon_{ij}$  = error from  $j$ th observation in group  $i$

A backwards stepwise method was then applied, and non-significant variables were eliminated based on the Akaike Information Criterion (AIC), to select the most parsimonious model.

AIC is expressed as:

$$AIC = 2k - 2\ln(\hat{L})$$

Where:  $k$  = number of estimated parameters in the model

$\hat{L}$  = maximum value of the likelihood function of the model

To assess the effect of mortality across different treatments, the natural logarithms of larval density against time was plotted and a linear regression line fitted through the data expressed as:

$$\ln(N_t) = \ln(N_o) - rt$$

Where:  $N_t$  = larval density at time  $t$  (larvae  $\mu\text{l}^{-1}$ )

$N_o$  = initial stocking density (larvae  $\mu\text{l}^{-1}$ )

$r$  is mortality ( $\text{d}^{-1}$ )

$t$  is age of the larvae (d).

An ANCOVA was then run to compare the relationships between the slopes at the different treatment levels.

The initial stocking densities at DPF 0 were excluded and the statistical analysis of the data followed the same ANCOVA method applied to larval growth in relation to time, testing the effect of the different treatments on mortality rate. The developmental stage of each larvae was recorded using the morphological characteristics based on the information described by Creek (1960). Homogeneity of variance was tested using the Levene's test and  $P < 0.05$  was used as a significant criterion in all analyses. All statistical tests were run using the software RStudio (version 0.98/R. 3.0.3).

### 3.3 Results

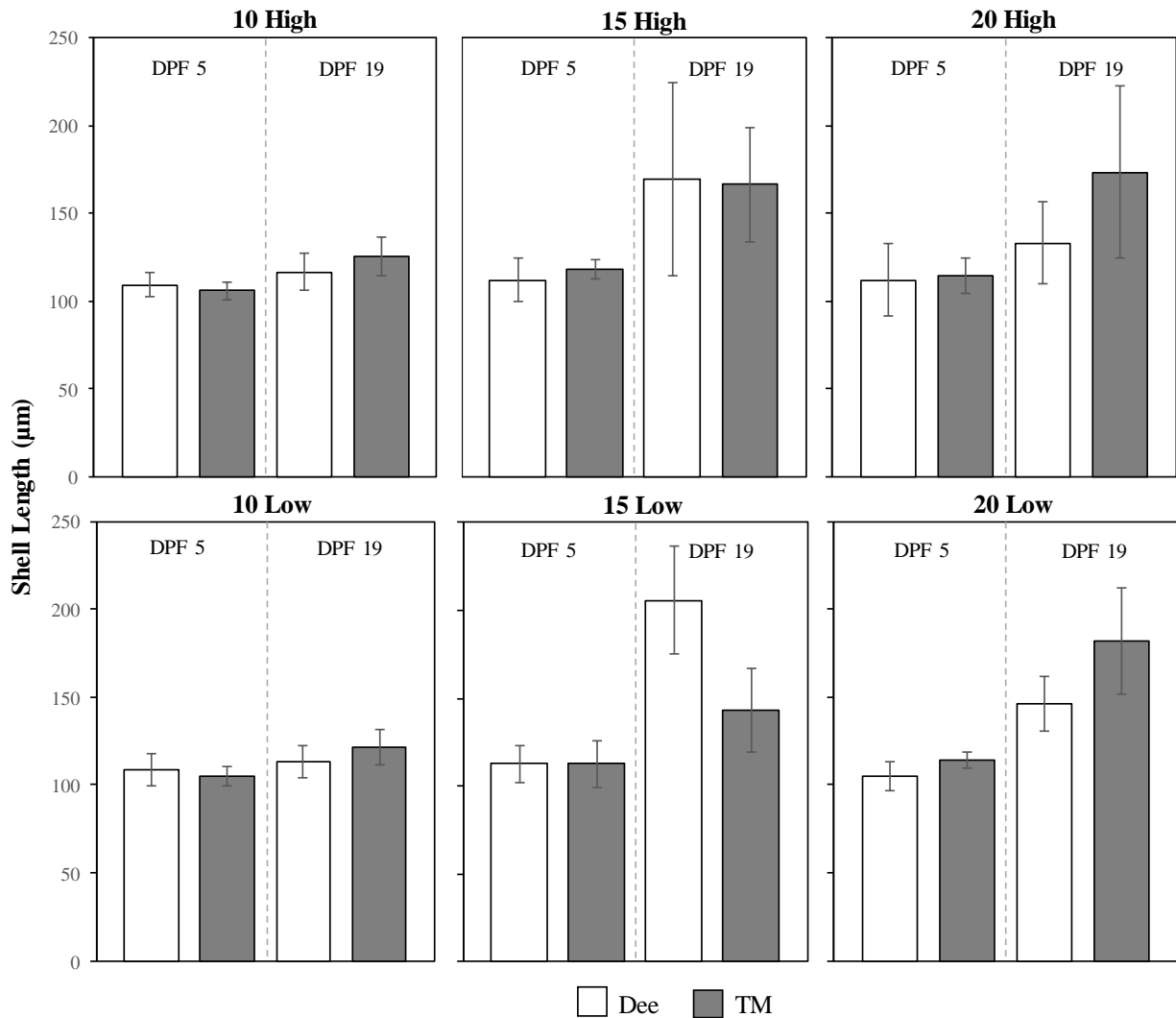
#### 3.3.1 Spawning

Successful spawning of the adult cockles generated approximately 160,000 fertilised eggs in total between both batches (Dee: 97,000 & TM: 63,000), enabling stocking densities of 5 and 3 individuals per  $\mu\text{l}^{-1}$  for the experiments 24 hours after the spawning process had begun. Fertilised eggs measured on average 73  $\mu\text{m}$  ( $\pm 1$ ) and 69  $\mu\text{m}$  ( $\pm 2.5$ ) respectively. The gelatinous membrane was not measured as this varied considerably in shape after fertilisation and it therefore became difficult to maintain consistency in the measurements. In both experiments, larvae successfully developed onto the D-larval stage and had an average shell length of 104  $\mu\text{m}$  ( $\pm 11$ ) (Dee) and 112  $\mu\text{m}$  ( $\pm 8$ ) (TM) on the first day of measurement. Maximum mean SL recorded from larvae during the veliger stage came from D15L (206  $\mu\text{m}$ ) and TM 20H (196  $\mu\text{m}$ ), whereas the maximum SL of a pediveliger larvae was measured from TM20H (280  $\mu\text{m}$ ) (Table 4). No pediveliger measurements were recorded in the Dee experiment.

### Chapter 3

**Table 4.** Shell lengths and growth rates of *Cerastoderma edule* larvae for each treatment during both experiments. H = high feed (100 cells. $\mu\text{l}^{-1}$ ), L = low feed (25 cells. $\mu\text{l}^{-1}$ ). For maximum size, days post fertilisation (DPF) are presented in parentheses.

Site	Treatment	Mean Shell length on first DPF ( $\pm 1$ SD)	Max Size at DPF 19	Max Size Recorded ( $\mu\text{m}$ ) (DPF)	Mean Max Size ( $\mu\text{m}$ ) (DPF)	Mean Growth $\mu\text{m.d}^{-1}$ ( $\pm 1$ SD)
Dee	D10 H	103 ( $\pm 12.3$ )	141	145 (21)	120 (21)	1.03 ( $\pm 10.7$ )
	D10 L	100.8 ( $\pm 12$ )	129	144 (16)	120 (16)	1.17 ( $\pm 2.3$ )
	D15 H	101.2 ( $\pm 18.1$ )	256	256 (19)	169 (19)	0.66 ( $\pm 10.5$ )
	D15 L	109.8 ( $\pm 8.6$ )	228	228 (19)	206 (19)	2.72 ( $\pm 8.7$ )
	D20 H	105.8 ( $\pm 7$ )	198	244 (12)	133 (19)	1.45 ( $\pm 4.3$ )
	20 L	105.6 ( $\pm 8.2$ )	158	209 (12)	146 (19)	0.99 ( $\pm 6.1$ )
Traeth Melynog	TM10 H	107.9 ( $\pm 7.9$ ) (DPF 5)	152	169 (21)	130 (21)	1.39 ( $\pm 3.1$ )
	TM10 L	107 (single individual)	149	185 (21)	136 (21)	1.55 ( $\pm 2.5$ )
	TM15 H	111.9 ( $\pm 2.6$ )	225	251 (21)	177 (21)	3.37 ( $\pm 3.1$ )
	TM15 L	112 ( $\pm 8.5$ )	207	226 (21)	152 (21)	2.3 ( $\pm 2.1$ )
	TM20 H	113.1 ( $\pm 20.2$ )	245	280 (21)	180 (21)	3.5 ( $\pm 4.6$ )
	TM20 L	112.2 ( $\pm 5.7$ )	244	261 (21)	182 (19)	3.17 ( $\pm 5.2$ )



**Figure 8.** Comparison of all shell length data taken from *Cerastoderma edule* larvae on DPF 5 and 19 from each experiment. Dee = white bars & TM = grey bars. Error bars =  $\pm 1$  standard deviation

### 3.3.2 Environmental affects on larval growth

#### *Differences between treatments on days 5 and 19*

Analysis of the treatment effect on the shell length of *Cerastoderma edule* larvae at day 5 from the Dee experiment, did not show any differences between either temperature, food concentration, or the interaction between the two (Table 5, Fig. 8). The maximum mean size reached by day 5 was 112.8 mm ( $\pm 10.5$ ) observed in the treatment D15L and the minimum was 104.9 mm ( $\pm 8.6$ ) observed in the treatment D20L (Fig. 8). From the experiment using larvae generated from Traeth Melynog, there was significant differences in the shell length across the different temperatures ( $p < 0.001$ ), but not for the food concentration or the interaction between



the two (Table 6, Fig. 8). The TukeyHSD test showed that these differences in size were between the paired comparisons of 10 °C and 15 °C ( $p<0.001$ ) and 10 °C and 20 °C ( $p<0.001$ ), but not between 15 °C and 20 °C ( $p=0.9$ ). Maximum mean size of larvae reached was 118.1 mm ( $\pm 5.4$ ) from the treatment TM15L and the minimum mean was 104.9 mm ( $\pm 5.7$ ) from the treatment TM10L (Fig. 8). No effect of food concentration or the interaction of temperature and food concentration was found in this experiment on day 5.

**Table 5:** ANOVA summary of the effect of temperature and feed on the shell length of larvae generated from broodstock collected from the Dee estuary on day 5 of the growth experiment.

Variable comparisons	df	Sum of Squares	Mean of Squares	F value	P value
Temp	2	166	82.98	0.539	0.585
Feed	1	111	110.86	0.720	0.398
Temp:Feed	2	261	130.47	0.847	0.432
Residuals	101	15555	154.01		

**Table 6:** ANOVA summary of the effect of temperature and feed on the shell length of larvae generated from broodstock collected from Traeth Melynog on day 5 of the growth experiment. Significant differences ( $p<0.05$ ) in bold.

Variable comparisons	df	Sum of Squares	Mean of Squares	F value	P value
Temp	2	1895	947.6	13.06	<b>&lt;0.001</b>
Feed	1	163	163.2	2.249	0.137
Temp:Feed	2	126	63.1	0.870	0.423
Residuals	91	6604	72.6		

Analysis of the treatment effect at day 19 from the Dee experiment showed that temperature had a significant effect ( $p<0.001$ ) on the shell length of the larvae (Table 7). The TukeyHSD test revealed differences between 10 °C and 15 °C ( $p<0.001$ ) and 15 °C and 20 °C ( $p=0.001$ ). No significant difference was observed between 10 °C and 20 °C. More variation in the shell sizes among temperatures were observed at this time point, compared to day 5. Larvae grew to a maximum mean size of 205 mm ( $\pm 30.7$ ) in the treatment D15L. The minimum mean size observed was 113.2 mm ( $\pm 9.5$ ) from the treatment D10L, which also displayed the smallest variation in sizes between all treatments at this time (Fig. 8). There was no effect of food concentration or the interaction between temperature and food concentration observed from the Dee experiment on day 19. The shell lengths of larvae from the Traeth Melynog

experiment also returned a significant difference between temperatures ( $p < 0.001$ ) (Table 8). The TukeyHSD test showed these differences to be present between all temperature comparisons: 10 °C and 15 °C ( $p < 0.001$ ); 10 °C and 20 °C ( $p < 0.001$ ) and 15 °C and 20 °C ( $p = 0.016$ ). The maximum shell length reached was less than larvae from the Dee at 182 mm ( $\pm 30.2$ ) and was observed in the treatment TM20L. Like larvae from the Dee experiment, the minimum mean shell length of was also observed in the treatment TM10L and reached 121.5 mm ( $\pm 9.8$ ) (Fig. 8). Food concentration was found to influence larvae shell length ( $p = 0.049$ ), however the interaction between temperature and food concentration was not significant (Table 8). In general, larvae from both experiments reared at 15 and 20 °C were larger in size on day 19 than those reared at 10 °C. However, the variation of shell sizes within each of the populations increased at these two temperatures suggesting that the rate at which the larvae grow at 15 °C and 20 °C can vary (Fig. 8). The maximum mean shell lengths were also observed in predominantly low food treatments, an indication that temperatures are more of a driver in determining shell length than food concentration. The results show that larvae are not restricted by the feed levels applied to the experiments in temperatures above 10 °C.

**Table 7:** ANOVA summary of the effect of temperature and feed on the shell length of larvae generated from broodstock collected from the Dee estuary on day 19 of the growth experiment. Significant differences ( $p < 0.05$ ) in bold.

Variable comparisons	df	Sum of Squares	Mean of Squares	F value	P value
Temp	2	27120	13560	19.089	<b>&lt;0.001</b>
Feed	1	448	448	0.631	0.431
Temp:Feed	2	2199	1100	1.548	0.224
Residuals	44	31255	710		

**Table 8:** ANOVA summary of the effect of temperature and feed on the shell length of larvae generated from broodstock collected from Traeth Melynog on day 19 of the growth experiment. Significant differences ( $p < 0.05$ ) in bold.

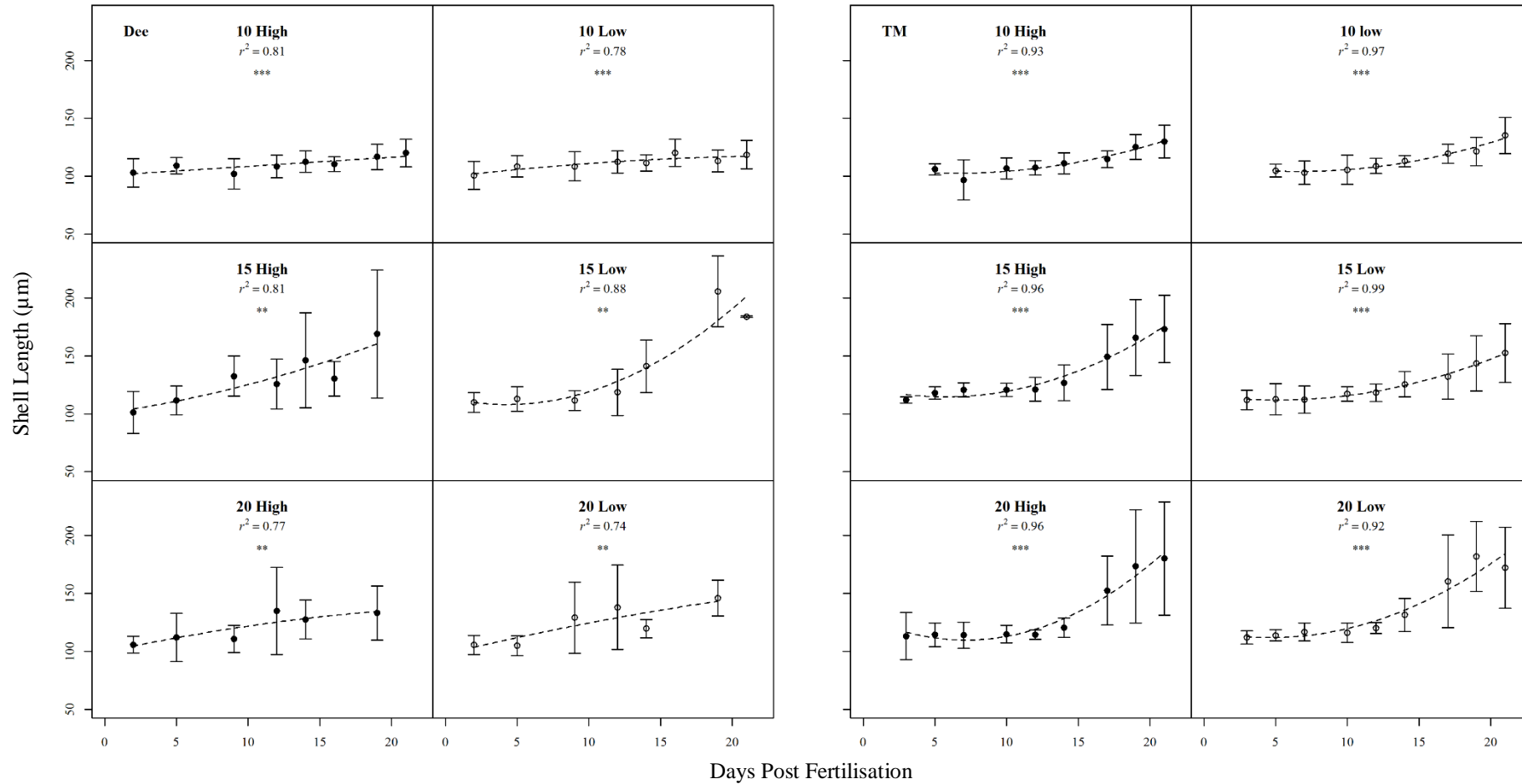
Variable comparisons	df	Sum of Squares	Mean of Squares	F value	P value
Temp	2	47080	23540	39.337	<b>&lt;0.001</b>
Feed	1	2361	2361	3.946	<b>0.0496</b>
Temp:Feed	2	3206	1603	2.679	0.0734
Residuals	104	62236	598		

***Differences in rate of growth between treatments***

The rate of growth over the duration of the experiments for *Cerastoderma edule* larvae was found to be significantly controlled by the 3-way interaction of time, temperature and site for both models (ANCOVA: (L) =  $F_{(2, 64)} = 13.7$ ,  $P < 0.001$ ; (Q) =  $F_{(2, 64)} = 5.7$ ,  $P = 0.005$ ). Time and temperature interaction were significant in both models (ANCOVA: (L) =  $F_{(2, 64)} = 35.2$ ,  $P < 0.001$ ; (Q) =  $F_{(2, 64)} = 4.1$ ,  $P = 0.02$ ), suggesting that temperature has an equal effect on growth no matter what the size of the individuals. Larval growth between sites was significantly different for the polynomial model ( $F_{(1, 64)} = 6$ ,  $P = 0.02$ ), suggesting that depending on site, larvae grew at different rates as they increased in size. Food concentration failed to produce any statistically significant result at the alpha level for any interaction, although there was some evidence of a difference in SL between time, food concentration and site in the polynomial model ( $p = 0.054$ ). This is likely to be driven by the differences in the slope between feeds within the 15 °C treatments (Fig. 9).

**Table 9.** ANCOVA outputs of the significant interactions that can explain the rate of growth in the linear (L) and polynomial (Q) regression models in response to the different treatments levels

Variable comparisons	df	Sum of Squares	Mean of Squares	F value	P value
DPF <sup>(L)</sup> : Temp:Site	2	1506.7	753.3	13.67	<0.001
DPF <sup>(Q)</sup> : Temp:Site	2	626.7	313.3	5.69	0.005
DPF <sup>(L)</sup> :Temp	2	3881.5	1940.7	35.21	<0.001
DPF <sup>(Q)</sup> : Temp	2	450.8	225.4	4.09	0.02
Temp:Site	2	793.5	396.8	7.2	0.002
DPF <sup>(Q)</sup> : Site	1	330.4	330.4	6	0.02
Temp	2	10129.1	5064.1	91.90	<0.001
DPF <sup>(Q)</sup>	1	2116	2116	38.40	<0.001
DPF <sup>(L)</sup>	1	20235.2	20235.2	367.20	<0.001
Residuals	64	3526.8	55.1		



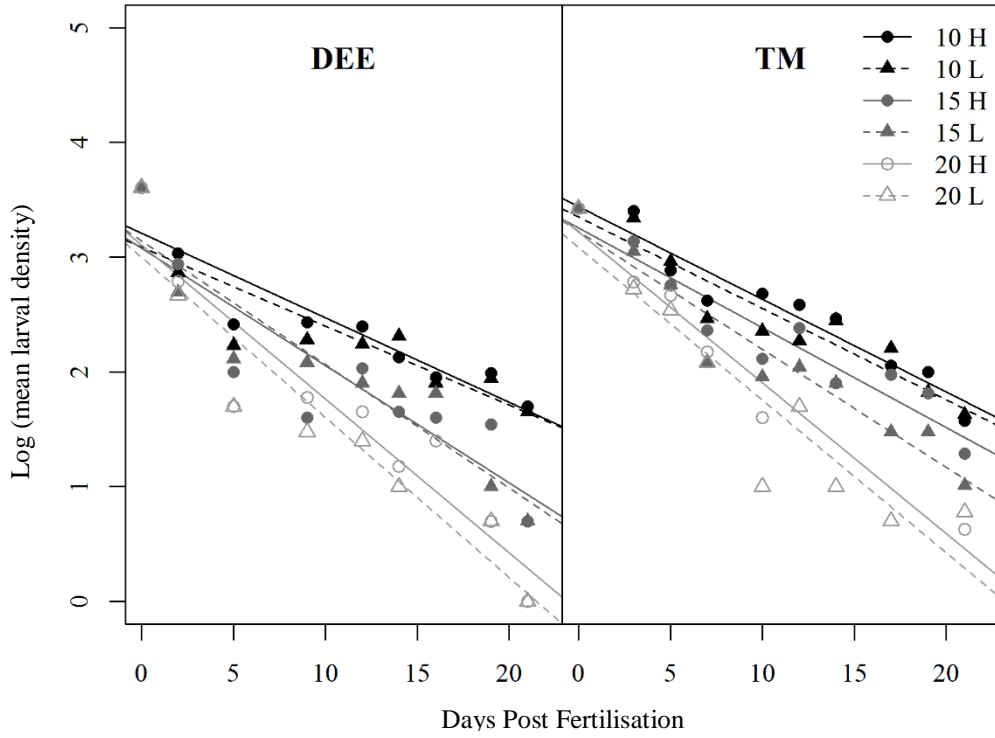
**Figure 9.** Mean growth of *Cerastoderma edule* larvae from each experiment (DEE = left, TM = right) and treatment level. Error bars  $\pm 1$  SD. Food concentration: High (100 cells  $\mu\text{l}^{-1}$ ): black circles & Low (25 cells  $\mu\text{l}^{-1}$ ): clear circles. 2<sup>nd</sup> order polynomial regression line of best fit with  $r^2$  values.  $P$  value = \*\*\* (<math>P < 0.001</math>) & \*\* (<math>P < 0.01</math>).

### 3.3.3 Combined environmental affects on larval mortality

Larval mortality was high throughout both experiments and averaged over 99% by the termination point. Arrested development in the early stages of embryonic division was observed in all treatments, and the greatest reduction in numbers occurred between the initial stocking estimation and the first day of measurement, where mortality averaged 65% of the initial stocking densities. Between sites, larvae originating from Dee stock, showed a greater decline in numbers during this time period. There was significant effect from the 2-way interaction of time and temperature on mortality ( $F_{(2, 97)} = 9.9, P < 0.001$ ). The variables of site and food concentration failed to explain any effect on mortality in any multiple interaction (Table 10). Two treatments, D20H and D20L, suffered total mortality between day 19 and day 21 (Fig. 10).

**Table 10.** ANCOVA summary of the significant effects of the explanatory variables on the mortality rates for *Cerastoderma edule* larvae across both experiments.

Variable comparisons	df	Sum of Squares	Mean of Squares	F value	P value
DPF	1	50.95	50.95	649.47	< 0.001
Food	1	0.71	0.71	9.10	0.003
Temp	2	10.55	5.27	67.22	< 0.001
Site	1	1.00	1.00	12.78	< 0.001
DPF:Temp	2	2.77	1.39	17.65	< 0.001
Residuals	100	7.85	0.08		



**Figure 10.** Mortality rates for *Cerastoderma edule* larvae during each experiment (left = Dee, right = TM) for the individual treatment levels.

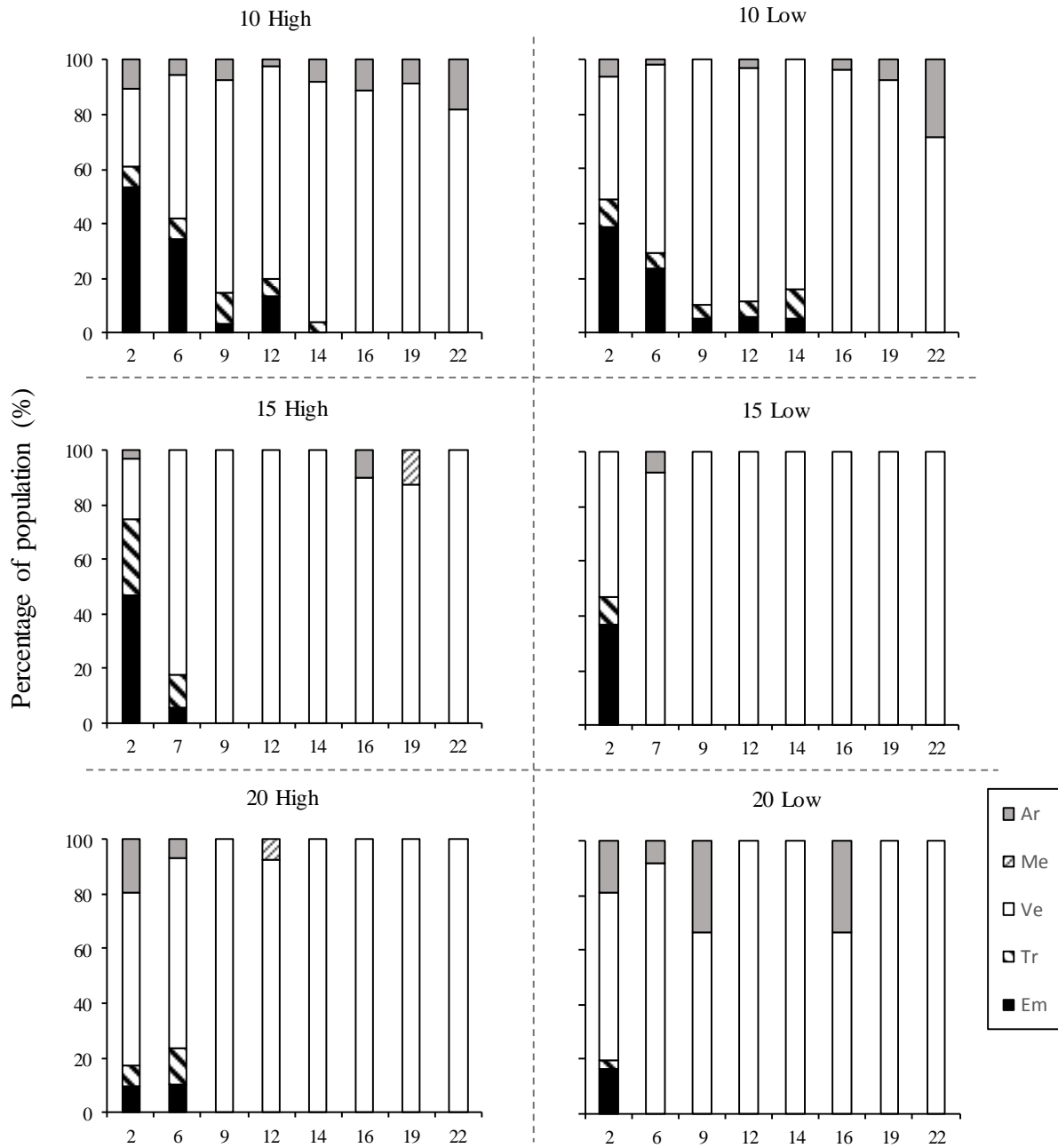
**Table 11.** Coefficients and  $r^2$  values for the regression slopes larvae mortality for *Cerastoderma edule* larvae during each experiment (Fig. 8).

Site	Treatment	Coefficient	$r^2$	% alive on first inspection (DPF)	Mean mortality Larvae.d <sup>-1</sup>
Dee	10 H	-0.074x + 3.201	0.86	26.7 (2)	206
	10 L	-0.069x + 3.086	0.76	18.2 (2)	138
	15 H	-0.102x + 3.076	0.79	21.6 (2)	173
	15 L	-0.108x + 3.140	0.87	12.2 (2)	98
	20 H	-0.134x + 3.104	0.88	15.2 (2)	143.5
	20 L	-0.140x + 2.999	0.89	11.5 (2)	175.7
TM	10 H	-0.081x + 3.442	0.93	95.6 (3)	501.4
	10 L	-0.080x + 3.352	0.90	82.3 (3)	430.2
	15 H	-0.087x + 3.254	0.90	52.1 (3)	272.6
	15 L	-0.103x + 3.230	0.93	42.4 (3)	223
	20 H	-0.132x + 3.222	0.96	22.9 (3)	120.7
	20 L	-0.133x + 3.087	0.86	19.9 (3)	104.8

### 3.3.4 Larval Development

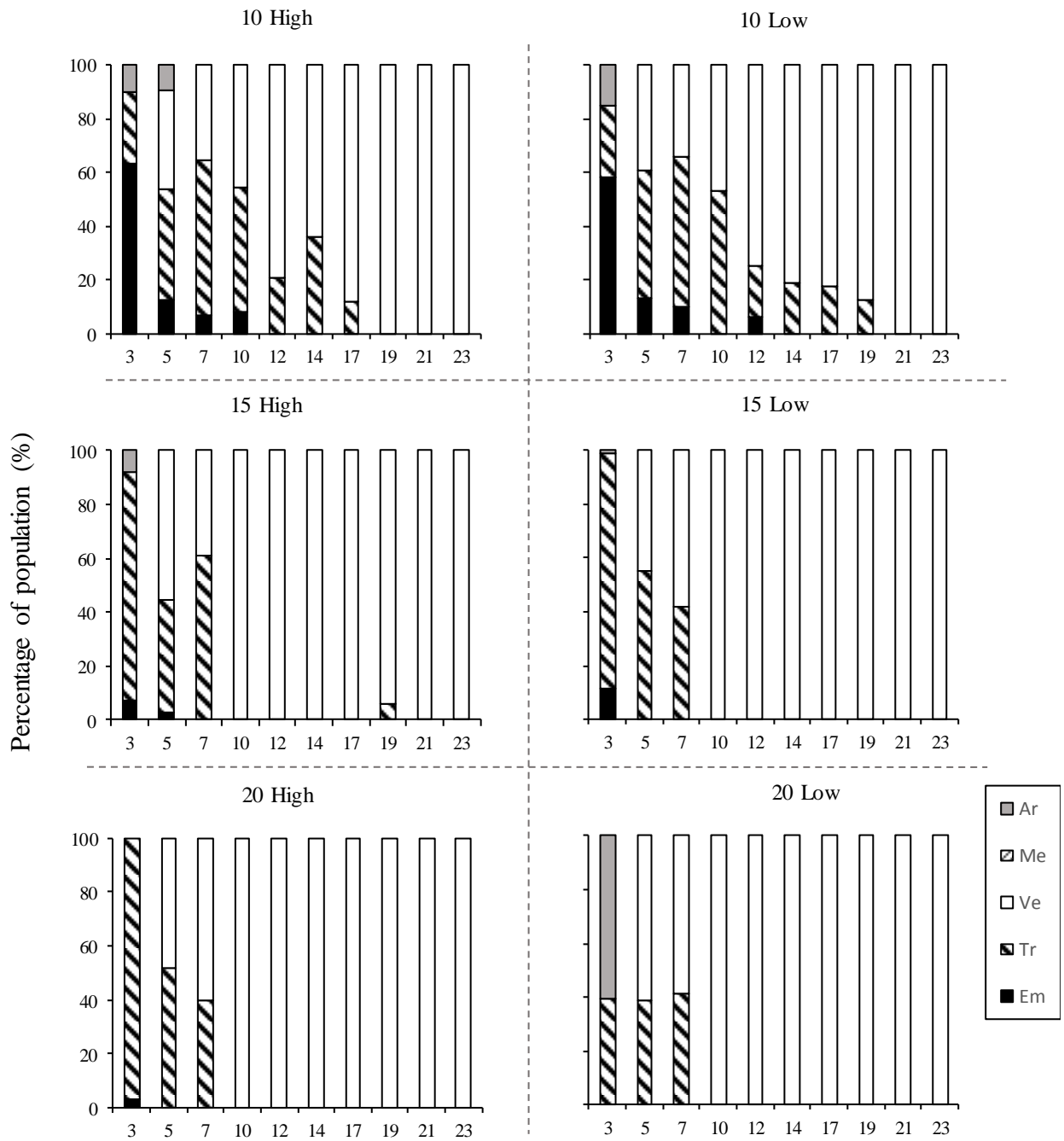
Throughout both experiments, all stages of cockle larval development were observed, and metamorphosis was reached by larvae reared in the 15 and 20°C treatments. No evidence of any metamorphosing or pediveliger larvae was found in the 10°C treatments and the maximum size reached for any larvae at this temperature was 145 µm (Dee) and 169 µm (TM) respectively (Table. 4). Differences in the proportion of larvae hatching from the gelatinous membrane were observed during the initial stages of development between experiments for those within 10°C treatments. The majority of larvae from TM failed to hatch from their membrane by DPF 3, although they were still developing normally and reaching the veliger stage prior to breaking free. This contrasts with those from the Dee, where all larvae had escaped the membrane after reaching the trochophore stage and were free swimming. In consequence, 95.6% (high) and 82.3% (low) of larvae remained alive at DPF 3 (TM), as compared to those remaining alive from the Dee at 26.7% (high) and 18.2% (low) (Table. 4).

Temperature influenced the developmental rate and the progression to the veliger stages. By DPF 9 (Dee) and 7 (TM), there were no unhatched embryos observed in the samples for both feeds from 15°C and 20°C, whereas others were still seen developing up until DPF 14 from the 10°C treatment (Fig. 11 & 12). Trochophores continued to be counted in both experiments for up to two weeks when at 10°C (high and low), but the larvae were able to pass this stage sooner at warmer temperatures (Fig. 11 & 12). The time when most larvae had reached the veliger stage was similar for all treatments in both experiments. By DPF 9, close to 100% of larvae still alive were at the veliger stage in the two warmer treatments (15°C or 20°C). Larvae reared at 10°C took longer to reach this stage, similar to the pattern that was present for the embryonic and trochophore stages. Recordings of larvae that had arrested during development (those showing signs of cellular deformity but were still alive or moving) were observed throughout the duration of the Dee experiment, particularly at the cooler 10°C. Fewer observations were made from the TM experiment, and only within the first few days (Fig. 12).



**Figure 11.** Percentage estimates for the observed development stages of *Cerastoderma edule* larvae during each of the sampling days spawned from the Dee estuary adults. Developmental stage code = Em: developing embryo (un-hatched), Tr: trochophore, Ve: veliger and pediveliger, Me: metamorphosed & Ar: arrested development/deformed larvae.





**Figure 12.** Percentage estimates for the observed development stages of *Cerastoderma edule* larvae spawned during each of the sampling days spawned from the Traeth Melynog adults. Developmental stage code = Em: developing embryo (un-hatched), Tr: trochophore, Ve: veliger and pediveliger, Me: metamorphosed & Ar: arrested development/deformed larvae.

### 3.4. Discussion

This study has been able to show that there is a positive relationship between rate of growth and water temperature. Larvae grew faster and took less time to reach metamorphoses when reared at 15 and 20 °C. Metamorphoses was not reached for larvae reared at 10 °C for either of the separate stocks. Mortality rates were found to be higher with elevated temperatures, indicating the larvae's sensitivity to changing environmental conditions and to the unavoidable process of image capture. Larval growth was not found to be influenced by the levels of food availability, however some differences in the shell lengths of larvae generated from Traeth Melynog broodstock were observed. They grew faster, reached metamorphoses earlier and survived for longer compared to larvae generated from broodstock from the Dee estuary.

#### 3.4.1 Combined affect of temperature and food concentration

This research on the pelagic stage of *Cerastoderma edule* larvae is one of only few studies that has targeted this pelagic stage of their life cycle and the only one, which we are aware of, that has manipulated both seawater temperature and food availability to assess their growth prior to settlement (Creek, 1960; Boyden, 1971; Kingston, 1974; Pronker et al., 2015). The combined effect of temperature and food concentration did not show any significant influence on the shell length of larvae in either of the experiments. However, between day 5 and day 19, there was clear evidence that the larvae increased in size within temperatures of 15°C and 20°C in both feeding regimes and this was the main driver of the differences in shell lengths observed (Fig. 8, Tables 7 & 8). Temperature is known to play a major role on the growth of marine organisms and has been well documented over the years. Higher temperatures promote faster and larger growth and allow for rapid development within a given period of time (Thornson 1950; Kingston, 1974, Sprung 1984; Drent 2002; Yund et al., 2016). The results of this study show that *C. edule* also has faster growth at higher temperatures. Larvae reared in aquaria at 15°C and 20°C, in general, achieve a larger size and grow and develop quicker than those reared at 10°C (Table. 4 & 9, Fig. 8 & 9). Throughout a spawning season larva are exposed to temperatures ranging between 7 - 18°C off the North Wales coast, and between 14 – 16°C in the months June and July (unpublished long-term data taken from the Menai Strait, North Wales). The intermediate temperature of 15°C was closest to the natural temperature *C. edule* larvae would have experienced if spawned during the peak part of the season (Hummel et al., (1989).

The affect of food concentration did show a relationship with shell length but only for cockles originated from Traeth Melynog. For these larvae, the high food concentration did encourage larger shell sizes across temperatures, but the results indicate the significance observed was mainly influences by larvae cultured in the 15°C treatment as this had the largest differences in size between the levels (Fig. 8). Larvae fed the high feed micro-algae diet (H), reached a mean size of 225µm (H) compared with those fed on the low feed diet (L) reaching 207µm (Table 4, Fig. 8). Our low feed micro-algae diet was considered to be sufficient to provide the necessary nutrients for the growth we observed and helped reinforce a temperature-controlled response, showing that high food availability provided in this study did not necessarily lead to increasing growth rates throughout the temperature ranges.

Past research on a range of intertidal bivalve larvae sharing the same habitat as *C. edule* in northern temperate regions has displayed a varied response to the manipulation of culture conditions. Kingston (1974) found a reduced rate of growth for *C. edule* larvae at 10°C whilst supplying a mono micro-algal species diet of *Isoschrysis galbana*, equivalent to 20 cells.µl<sup>-1</sup> (calculated from stocking density and volume of culture vessels). Shell lengths of approximately 150 µm (10°C), 200 µm (15°C) and 270 µm (20°C) (within Kingston, 1974 – Figure 1), were recorded at an equivalent age and are comparable to our larvae sizes reared in the low feed treatments (Table. 4). In a more recent study, the algal species *I. galbana*, *Pavlova lutherii* and *Chaetoceros muelleri* (ratio: 1:1:1) were fed to cockle larvae at a concentration of 80 cells.µl<sup>-1</sup>, and a growth rate of 16.4µm.d<sup>-1</sup> in 19°C seawater (single temperature cultures) was then observed (Pronker et al., 2015). This is almost an eightfold increase compared to our 20°C treatments ( $\bar{x}$ 2.28 ±10.1µm.d<sup>-1</sup>). Research on *Mytilus edulis* and *Macoma balthica* larvae, display similar seasonal spawning patterns (Seed and Brown, 1977), have, depending on the study, responded differently to these environmental conditions in laboratory experimentation. Bayne (1965), found the larvae of *M. edulis* display the greatest rate of growth when fed a duo of micro-algae species diet (*Pavlova Lutheri* and *Isochrysis galbana*) at a concentration of 100 cells.µl<sup>-1</sup>. This is supported by Pechenik et al., (1990), who found *M. edulis* growth rates increase (maximum 8.1µm.d<sup>-1</sup>) with increasing algal concentration (range: 5 – 300 cells.µl<sup>-1</sup>) at 16°C, although they were fed on only a single micro-algae species. For *M. balthica* larvae, research manipulating the quantity of food over a 3-week period found a positive relationship between growth rate and high levels (80 cells.µl<sup>-1</sup>) of phytoplankton in 15°C seawater, resulting in the larvae growing faster and metamorphosing at a larger size. Average growth across all treatments recorded by the authors was 5.7 ±0.7µm.d<sup>-1</sup> (Bos et al., 2007). Our own growth rates over both experiments ranged from a minimum 0.66 ±10.5µm.d<sup>-1</sup>

<sup>1</sup> (D15H) to a maximum  $3.5 \pm 4.6 \mu\text{m}\cdot\text{d}^{-1}$  (TM20H), with an overall mean of  $1.94 \pm 5.09 \mu\text{m}\cdot\text{d}^{-1}$  (Table 4) and are therefore towards the lower ranges of observations made in the above studies.

Growth of *M. edulis*' has been shown to plateau at a micro-algae concentration of 10 cells. $\mu\text{l}^{-1}$  and above (mono-species diet of *I. galbana*) in temperatures of 6, 12 and 18 °C. Growth rate, however, did increase with elevating temperatures (3.4, 8.1 and  $11.8 \mu\text{m}\cdot\text{d}^{-1}$  respectively) suggesting that the lowest feed was optimal for this study (Sprung, 1984). Achieving optimal growth for *M. edulis* larvae is between 10 – 50 cells. $\mu\text{l}^{-1}$  at larvae concentrations of 0.1 – 10 organisms  $\text{ml}^{-1}$  (Bayne, 1965; Jespersen and Olsen, 1982; Gosling, 1992). Unfortunately, as there are few studies concentrating on the pelagic larval phase of *C. edule*, knowledge of the optimal food concentration for growth is insufficient. It was therefore difficult to assess the suitability of the chosen micro-algae densities as the methodology used is not consistent among studies, making comparisons between results difficult. Our study assigned micro-algae concentrations based on species that are of interest and are suited for commercial aquaculture – and thus considered to be a suitable estimate for rearing *C. edule* larvae (Marshall et al., 2010). *Macoma balthica* spawn earlier in the season (February to April), outside the peak phytoplankton bloom. Their larvae can survive and grow in these conditions, and it is believed that this mismatch with food, benefits the larvae by avoiding predation from crustaceans and thus increasing their opportunity for survival (Bos et al., 2006). It also highlights that food density is not necessarily the main factor controlling growth.

### **3.4.2 Affect of temperature and food concentration on growth rate**

During the growth experiment using larvae reared from Traeth Melynog cockles, the growth rate of the larvae increased exponentially when they reached approximately 120 $\mu\text{m}$  SL in the 15°C and 20°C treatments (Fig. 9). It is plausible that this observation indicates a size dependant threshold for larvae. Once a particular size is reached, the larvae are big enough to be able to utilise the available algae more effectively and be physically able to ingest species of a larger cell size. An analysis of stomach contents on bivalve larvae from the temperate regions of western Canada has shown that small flagellates (<5  $\mu\text{m}$ ) and cyanobacteria (<2  $\mu\text{m}$ ) account for the majority of gut content, dependant on the species tested (Raby et al., 1997). Our micro-algae feed ranged between 3 – 15  $\mu\text{m}$  in cell diameter and the combination of species was allocated on the availability of existing cultures at the time of the experiments and the recommendations found in the literature (Lavens and Sorgeloos, 1996; Brown, 2002; Helm,

2004). Raby et al. (1997) demonstrated that *Mytilus edulis* larvae ingested significantly larger particles as they increased in size compared to *Mya arenaria* and *Placopecten magellicanus*. Particle selection was not tested in our experiment and had not yet been addressed in the literature, but it is entirely possible our larvae were gaining more benefit from the micro-algae feed as they too increased in size.

Phytoplankton in the Irish Sea consists of diatoms, dinoflagellates, and smaller flagellates that are part of the nanoplankton (2 – 20 µm cell diameter) and picoplankton (0.2 – 2 µm cell diameter). The smaller groups of cells are a vital food source for marine invertebrate larvae (Kennington and Rowlands, 2006). A total of ten genus groups (comprising of multiple species) and thirty-one other individual phytoplankton species has been positively identified in more than 1% of the samples taken off the coast of North Wales (SAHFOS, 2016). Natural food availability is different to that which is used in a closed culture environment and it should therefore be expected that organisms reared in a laboratory might not respond as they would in the wild. In commercial bivalve aquaculture, it is recommended that a mixture of micro-algae diets are used to provide larvae with their optimal nutritional needs (Bayne 1965; Utting & Millican 1997; Helm, 2004; Galley et al., 2010; Aranda-Burgos et al., 2014). The species commonly used have been selected over the years on the requirements that they provide maximum growth by being ingestible; they are digestible with a good nutrient composition; they can be cultured in large densities; and they are stable during the cultivation process (Brown, 2002). This selective process has limited the availability of micro-algae for culture purposes to just a handful of species and goes against what a natural population would experience. Early research on *Ostrea edulis*, the European flat oyster, showed larvae reared in outside ponds developed rapidly when allowed to feed on unfiltered seawater compared to those reared in controlled aquaria (Bruce et al., 1940). In a natural environment, bivalve larvae experience a large diversity of phytoplankton, but in reduced densities compared to those reared in aquaculture environments. In aquaculture increasing the availability of targeted feeds are known to maximise growth rate (Gosling, 2003). Designing experiments to incorporate a natural supply of seawater would be beneficial for testing the larva's response to these environmental conditions. Using unfiltered seawater poses inherent problems: it is difficult to control, and it introduces unwanted contaminants, bacteria, and other marine species that could otherwise interfere with sterile cultures. It is possible that the growth seen in the few larval studies is not a true biological representation. *C. edule* larvae most likely respond differently in the natural environmental but testing this has yet to be achieved. Further research to monitor the density and growth of naturally spawned larvae is needed in order to make accurate

comparisons of how the combined effect of temperature and food concentrations effects the larva's growth and development.

### 3.4.3. *Development of Cerastoderma edule larvae*

The end of their pelagic phase and the point when *Cerastoderma edule* larvae begin to metamorphose and lose their velum is generally is triggered when reaching a shell length of around 270  $\mu\text{m}$  (Creek, 1960). This can take between 17 and 30 days at 15°C and between 9 to 24 days at around 20°C (Kingston, 1974; Jonsson et al., 1991; Pronker et al., 2014). Based on these facts, we expected more recordings of metamorphosed individuals than occurred (Figs 11 & 12). The presence of a few individuals reaching this stage of their life does suggest our larvae were biologically capable, and it is therefore also suggestive of to a possible experimental effect on development. Either the sampling method for recording shell length (i.e. not selecting individuals which had come out of suspension whilst taking the sub-samples) or mortality prior to metamorphoses may justify these findings. It is evident from the observations that 10°C does not support a fast transition through the larval stages, extending the larval phase beyond what may be considered normal. The duration of 21 days could possibly have been too short to achieve metamorphoses or, ultimately, the larvae may never reach this phase at this temperature. Larvae which are released early in the season (March/April) may not reach a suitable size for metamorphosis to occur within a reasonable amount of time (Kingston, 1974). This is because of seawater temperatures are at their lowest and near to the lower tolerance limits. Consequences of a longer period of time spent transitioning through the larval stages include the increased chance of environment induced mortality and the possibility of the tides and currents transporting larvae away from a suitable settlement habitat. Re-suspension of free-swimming larvae during the pelagic phase can also lead to larviphagy by adult bivalves, effecting cockle bed recruitment and ecosystem balance (Andre & Rosenberg, 1991; Troost et al., 2008). Self-replenishing populations such as those at the Burry Inlet in South Wales and the Wash embayment on the east coast of England could be worse affected leading to poor recruitment during the spawning season if premature spawning occurs (Ke et al., 1996; Sponaugle et al., 2002; Coscia et al., 2013).

Hatching from the gelatinous membrane should take place when the larvae have reached the veliger stage of development (Alatalo et al., 1984; Wassnig and Southgate, 2011). Why we observed hatching during the trochophore stage, particularly within larvae originating

from the Dee estuary, is not known. Yankson and Moyses (1983) recorded a greater percentage of unhatched veliger's with increasing egg densities; however, our egg densities were substantially lower than in this study and unlikely to have had an effect. Another possible explanation could be the ferocity of aeration in the culture beakers, agitating the water significantly enough to induce premature hatching. Whether physical disturbance promotes hatching in wild larval populations requires further investigation. The gelatinous membrane provides protection against shear-stress and the physical forces in the dynamic intertidal environment and would help to prevent irreversible damage to developing larva (Thomas et al., 1999). This points towards membrane encapsulation until the 1<sup>st</sup> prodissoconch shell has formed, giving the protection required in the early trochophore stage and following the pattern seen in other species (Alatalo et al., 1984; Wassnig and Southgate, 2011). Our observations show that shell length by DPF 5 was not affected by the difference between free-swimming or encapsulated trochophores, and that trochophore larvae which had hatched within the cultures appeared to successfully develop onto the next stage as numbers of observations in the treatments reduced over time (Figs. 11 and 12). Survival may have been reduced as a significant drop in numbers was observed in the Dee experiment between DPF 0 and DPF 2, however it remained untested. The appearance of trochophore in the samples up until 2 weeks into the experiments does suggest that environment in which we reared the larvae did not generate too much stress on the larvae and enabled trochophores to continue surviving.

#### **3.4.4. *Affect on mortality***

In the experiment, mortality was significantly linked to temperature and time but was unaffected by food concentration (Table 10). Larvae were therefore not starved and there was no difference of the culture methods between batches of larva. Survival was at its highest at 10°C and this supports the findings by Yund et al. (2016). As temperature increases, bacterial growth increases, reducing water quality and promoting infection (Devakie & Ali 2000; Joaquim et al., 2016). Bacterial growth can increase if there are excessive algal cells present in the cultures, as algal cells die, they begin to decompose which in turn fuels bacterial growth. This poses a significant threat to small scale, self-contained environments: water quality deteriorates as a result of cell decomposition from the phytoplankton cells that fail to get ingested by the larvae (Loosanoff & Davis 1963; Helm & Bourne 2004). Our cultures contained two potential vectors for unwanted bacteria to flourish that could have contributed to the

observed mortality. The presence of empty shells from larvae that had suffered mortality were difficult to separate as they were of equal size to those still alive. Excess algal cells were also observed clumping together at the bottom of the culture vessels and were not able to pass through the mesh. Both factors place unwanted pressure on the larvae and increase the chances of a negative response to the culture environment. Adding “antibiotics” or “probiotics” to larval cultures to protect against unwanted bacteria and help improve survival and growth may be effective. This is common practise in commercial aquaculture (Douillet and Langdon, 1994), but the specific effect on *Cerastoderma edule* larvae is untested and therefore, neither were added in our experiments. As larvae are sensitive, sampling, water changes and cleaning in both experiments were conducted at intervals of 2 – 3 days – an accepted period of time in bivalve larval cultures to limit the stress placed upon the larvae. Extra care during the filtering process was also required to prevent external shell damage and mortality.

#### **3.4.5. Spawning procedure for generating *Cerastoderma edule* larvae**

The protocol developed in this study was able to provide enough larvae for the small-scale experiments but was only successful when using a high density of adult broodstock (~200 individuals, >20mm SL), in an attempt to replicate localised spawning event. Spawning commenced soon after the cockles were placed in the tank, white clouds of sperm were observed being released. It is believed that females spawn after the males and use chemical cues as a trigger. No observations of females spawning were made in our experiment. Other ways of obtaining gametes were not tested as it is accepted that temperature induced spawning is the most suited for generating viable bivalve larvae (Utting and Spencer, 1991; Hooker, 1997; Helm, 2004; Lui et al., 2008). Egg size upon release was consistent (excluding gelatinous membrane) and within the ranges describe by other studies (Creek, 1960; Honkoop and van der Meer, 1998; Pronker et al., 2014). However, considering the high number of adults present in the spawning tank, the total number of eggs captured was low. Individual female cockles of similar size can produce between 200,000 – 700,000 eggs (Honkoop and van der Meer, 1998) and Pronker et al., (2014) were able to generate over 3 million from 12 adult females from laboratory conditioned broodstock where gametogenesis and gamete release was controlled. Our experiments commenced in the months May and July, so there is a strong possibility the broodstock had already spawned by this time. Upon inspection of the gonads, cockles from the Dee Estuary were considered spent by the end of July 2015. However, spat measuring between



1 – 2 mm SL were observed in the Dee estuary cockle beds during November 2014, pointing towards a second spawning event that would likely have commenced in September 2014. Successful spawning has been recorded up until September by Lebour (1938) from cockles collected along the southern coast of the UK. Preliminary spawning attempts conducted in July 2014 were successful in generating larvae up until late July using Traeth Melynog cockles, although the quantity of eggs was reduced. It is evident from the developmental stages of the gonads over the season, and the presence of post settlement spat throughout the summer months, that spawning is a polycyclic process which varies on geographical location, and can lead to differences in the synchrony of male and female gametes and thus influence the reproductive success of a population (Lebour 1938; Baggerman 1954; Boyden 1971; Kingston 1974; Seed and Brown, 1977; Newell and Bayne, 1980; Yankson, 1986; Jensen, 1992; Wehrmann 1999; Martinez-Castro & Vázquez, 2012; Morgan et al., 2013).

#### 3.4.6 Summary

This study has addressed *Cerastoderma edule*'s larval stages in relation to their parental site of origin, over a range of different environmental conditions. It has shown that larvae increase in size at a faster rate in temperatures higher than 10°C but the benefit of parental heritage or food availability to their growth and development is inconclusive. It has also highlighted how sensitive the larval stage is to stress through the high mortality observed. There are aspects to this study which could be improved on or eliminated in future research. Studies should ensure that experimental design eliminates stress on the larvae and not induce mortality. Attempting to accurately replicate conditions (i.e. for temperature and food availability) in much larger laboratory environments would also be of benefit as more larvae can be used, with less interference. Although challenging, attempting to cultivate and rear larvae within the natural environment would also be beneficial and eliminate the effects of aquaria-based experiments and reduce error in the results. Temperature, salinity, food, stocking densities, predation, larval development time, time and location of settlement, adult condition and extreme weather patterns all play a role in the larvae's success and promote recruitment to the cockle beds. Research on this life-cycle stage for *C. edule* remains relatively immature and a disproportionate amount of research on the larvae of other species of bivalves exists. Investing in research on *C. edule* will help to further understand how the role biotic and abiotic factors have, and the scale at which they influence cockle growth and development. Ultimately leading

### *Chapter 3*

to the availability of adult stocks to a fishery. Further investigation into parasites and pathogens and the knock-on effects of ocean acidification brought on by climate change are equally important and should be addressed (Longshaw & Malham 2012; Kurihara 2008). Testing which senses are used during cockle larval development and settlement can help to unravel the transition from the pelagic to the benthic environment (Kingsford et al. 2002). Research on genetic analysis of individual cockles will also improve our understanding on stock recruitment processes and better aid fisheries management procedures (Coscia et al. 2012; Malham et al. 2012). As fisheries and aquaculture businesses are playing an imperative role in supplying nutritional and protein needs too much of the world's population, the supply for their products has dramatically increased over the last half century (FAO, 2018). It is essential that recruitment of cockles to commercial fisheries can to keep up with this increasing demand.

### 3.5 References

- Alatalo, P., Berg Jr, C.J. and D'Asaro, C.N., 1984. Reproduction and development in the lucinid clam *Codakia orbicularis* (Linne, 1758). *Bulletin of marine science*, 34(3), pp.424-434.
- André, C. and Rosenberg, R., 1991. Adult-larval interactions in the suspension-feeding bivalves *Cerastoderma edule* and *Mya arenaria*. *Marine ecology progress series*, pp.227-234.
- Aranda-Burgos, J.A., da Costa, F., Nóvoa, S., Ojea, J. and Martínez-Patiño, D., 2014. Effects of microalgal diet on growth, survival, biochemical and fatty acid composition of *Ruditapes decussatus* larvae. *Aquaculture*, 420, pp.38-48.
- Baggerman, B., 1954. Spatfall and transport of *Cardium edule* L. *Archives néerlandaises de zoologie*, 10(3), pp.315-342.
- Bayne, B., 1965. Growth and the delay of metamorphosis of the larvae of *Mytilus edulis* (L.). *Ophelia*, 2(1), pp.1-47.
- Beukema, J.J. and Dekker, R., 2005. Decline of recruitment success in cockles and other bivalves in the Wadden Sea: possible role of climate change, predation on postlarvae and fisheries. *Marine ecology progress series*, 287, pp.149-167.
- Bos, O.G., Philippart, C.J., Cadée, G.C. and Van der Meer, J., 2006. Recruitment variation in *Macoma balthica*: a laboratory examination of the match/mismatch hypothesis. *Marine ecology progress series*, 320, pp.207-214.
- Bos, O.G., Philippart, C.J. and Van der Meer, J., 2007. Effects of temporary food limitation on development and mortality of *Macoma balthica* larvae. *Marine ecology progress series*, 330, pp.155-162.
- Boyden, C.R., 1971. A comparative study of the reproductive cycles of the cockles *Cerastoderma edule* and *C. glaucum*. *Journal of the marine biological association of the United Kingdom*, 51(03), pp.605-622.
- Boyden, C.R., 1972. The behaviour, survival and respiration of the cockles *Cerastoderma edule* and *C. glaucum* in air. *Journal of the marine biological association of the United Kingdom*, 52(03), pp.661-680.
- Brenko, M.H. and Calabrese, A., 1969. The combined effects of salinity and temperature on larvae of the mussel *Mytilus edulis*. *Marine biology*, 4(3), pp.224-226.
- Brown, M.R., 2002. Nutritional value and use of microalgae in aquaculture. *Avances en Nutrición Acuícola VI. Memorias del VI Simposium Internacional de Nutrición Acuícola*, 3, pp.281-292.
- Bruce, J.R., Knight, M. and Parke, M.W., 1940. The rearing of oyster larvae on an algal diet. *Journal of the marine biological association of the United Kingdom*, 24(01), pp.337-374.
- Burdon, D., Callaway, R., Elliott, M., Smith, T. and Wither, A., 2014. Mass mortalities in bivalve populations: A review of the edible cockle *Cerastoderma edule* (L.). *Estuarine, coastal and shelf science*, 150, pp.271-280.
- Cadee, G.C., 1986. Recurrent and changing seasonal patterns in phytoplankton of the westernmost inlet of the Dutch Wadden Sea from 1969 to 1985. *Marine biology*, 93(2), pp.281-289.
- Camphuysen, C.J. et al., 2002. Mass mortality of common eiders (*Somateria mollissima*) in the Dutch Wadden Sea, winter 1999 / 2000: starvation in a commercially exploited wetland of international importance. *Biological conservation*, 106, pp.303-317.
- Carriker, M.R., 1961. Interrelation of functional morphology, behaviour, and autecology in early stages of the bivalve *Mercenaria mercenaria*. *Journal of the elisha mitchell scientific society*, 77(2), pp.168-241.
- Cesar, C., 2009. The roles of the cockle *Cerastoderma edule* L. on ecosystem functioning: cockle comings and goings. *University of Liverpool*, pp.179.

### Chapter 3

- Coscia, I., Robins, P.E., Porter, J.S., Malham, S.K. and Ironside, J.E., 2013. Modelled larval dispersal and measured gene flow: seascape genetics of the common cockle *Cerastoderma edule* in the southern Irish Sea. *Conservation genetics*, 14(2), pp.451-466.
- Creek, G.A., 1960. The development of the lamellibranch *Cardium edule* L. *Proceedings of the zoological society of London*, 135(2), pp.243-260.
- Cushing, D.H., 1975. *Marine ecology and fisheries*. Cambridge University Press, Cambridge.
- Cushing, D.H., 1990. Plankton production and year-class strength in fish populations: an update of the match/mismatch hypothesis. *Advances in marine biology*, 26, pp.249-293.
- Davis, H.C. and Calabrese, A., 1964. Combined effects of temperature and salinity on development of eggs and growth of larvae of *M. mercenaria* and *C. virginica*. *Fishery Bulletin*, 63(3), pp.643-655.
- Demontaudouin, X. and Bachelet, G., 1996. Experimental evidence of complex interactions between biotic and abiotic factors in the dynamics of an intertidal population of the bivalve *Cerastoderma edule*. *Oceanologica acta*, 19(3-4), pp.449-463.
- Devakie, M.N. and Ali, A.B., 2000. Salinity–temperature and nutritional effects on the setting rate of larvae of the tropical oyster, *Crassostrea iredalei* (Faustino). *Aquaculture*, 184(1), pp.105-114.
- Dijkema, R., 1992. The risk of provoking toxic dinoflagellate blooms in the Dutch coastal waters through immersion of imported bivalves, originating from red tide areas (p. 11). *International Council for the Exploration of the Sea, Shellfish Committee*.
- Dolmer, P., Christensen, H.T., Hansen, B.W. and Vismann, B., 2012. Area-intensive bottom culture of blue mussels *Mytilus edulis* in a micro-tidal estuary. *Aquaculture environment interactions*, 3(1), pp.81-91.
- Douillet, P.A. and Langdon, C.J., 1994. Use of a probiotic for the culture of larvae of the Pacific oyster (*Crassostrea gigas* Thunberg). *Aquaculture*, 119(1), pp.25-40.
- Drent, J., 2002. Temperature responses in larvae of *Macoma balthica* from a northerly and southerly population of the European distribution range. *Journal of experimental marine biology and ecology*, 275(2), pp.117-129.
- Ducrottoy, J.P., Rybarczyk, H., Souprayen, J., Bachelet, G., Beukema, J., Desprez, M., Dörjes, J., Essink, K., Guillou, J., Michaelis, H. and Sylvand, B., 1991. A comparison of the population dynamics of the cockle (*Cerastoderma edule*, L.) in north-western Europe. *Estuaries and coasts: spatial and temporal intercomparisons*, pp.173-184
- Edwards, M. & Richardson, A. J., 2004. Impact of climate change on marine pelagic phenology and trophic mismatch. *Nature*, 430, pp.881-883.
- Eriksson, B.K. et al., 2010. Major Changes in the Ecology of the Wadden Sea: Human Impacts, Ecosystem Engineering and Sediment Dynamics. *Ecosystems*, 13(5), pp.752–764.
- FAO. 2018. *The State of World Fisheries and Aquaculture 2012*, Food and Agriculture Organisation of the United Nations. Rome, pp.210
- Flach, E.C., 1996. The influence of the cockle, *Cerastoderma edule*, on the macrozoobenthic community of tidal flats in the Wadden Sea. *Marine Ecology*, 17(1-3), pp.87-98.
- Fotel, F.L., Jensen, N.J., Wittrup, L. and Hansen, B.W., 1999. In situ and laboratory growth by a population of blue mussel larvae (*Mytilus edulis* L.) from a Danish embayment, Knebel Vig. *Journal of experimental marine biology and ecology*, 233(2), pp.213-230.
- Garen, P., Robert, S. and Bougrier, S., 2004. Comparison of growth of mussel, *Mytilus edulis*, on longline, pole and bottom culture sites in the Pertuis Breton, France. *Aquaculture*, 232(1), pp.511-524.
- Genelt-Yanovskiy, E. et al., 2010. Population structure and growth rates at biogeographic extremes: a case study of the common cockle, *Cerastoderma edule* (L.) in the Barents Sea. *Marine pollution bulletin*, 61(4-6), pp.247–53.

### Chapter 3

- Gosling, E. ed., 1992. The mussel *Mytilus*: ecology, physiology, genetics and culture (No. 594.1 MUS). Amsterdam: Elsevier.
- Gosling, E., 2003. Ecology of Bivalves. Bivalve molluscs: biology, ecology and culture. Fishing news books, Blackwell, Oxford, pp.44-86.
- Goss-Custard, J.D. et al., 2004. When enough is not enough: shorebirds and shellfishing. Proceedings of the royal society London, 271(1536), pp.233-7.
- Gouletquer, P., 2004. Cultured Aquatic Species Information Programme In: FAO Fisheries and Aquaculture Department, Rome.
- Hancock, D. & Franklin, A., 1972. Seasonal changes in the condition of the edible. British ecological society, 9(2), pp.567-579.
- Helm, M.M., Bourne, N. and Lovatelli, A., 2004. Hatchery culture of bivalves: a practical manual. Food and agriculture organization of the United Nations.
- His, E., Robert, R. and Dinet, A., 1989. Combined effects of temperature and salinity on fed and starved larvae of the Mediterranean mussel *Mytilus galloprovincialis* and the Japanese oyster *Crassostrea gigas*. Marine biology, 100(4), pp.455-463.
- Hooker, S.H., 1997. Larval and postlarval development of the New Zealand pipi, *Paphies australis* (Bivalvia: Mesodesmatidae). Bulletin of marine science, 61(2), pp.225-240.
- Honkoop, P.J.C., Van der Meer, J., Beukema, J.J. and Kwast, D., 1998. Does temperature-influenced egg production predict the recruitment in the bivalve *Macoma balthica*? Marine ecology progress series, 164, pp.229-235.
- Honkoop, P.J., Berghuis, E.M., Holthuijsen, S., Lavaleye, M.S. and Piersma, T., 2008. Molluscan assemblages of seagrass-covered and bare intertidal flats on the Banc d'Arguin, Mauritania, in relation to characteristics of sediment and organic matter. Journal of sea research, 60(4), pp.255-263.
- Hummel, H., Bogaards, R.H., Ryland, R. and Tyler, P.A., 1989. Changes in the reproductive cycle of the cockle *Cerastoderma edule* after disturbance by means of tidal manipulation. In Reproduction, Genetics and Distributions of Marine Organisms. Proceedings 23rd European Marine biology Symposium School of Biological Science University of Wales, Swansea (pp. 133-136). Olsen & Olsen.
- IPCC, 2014: Climate Change 2014: Synthesis Report. Contribution of Working Groups I, II and III to the Fifth Assessment Report of the Intergovernmental Panel on Climate Change [Core Writing Team, R.K. Pachauri and L.A. Meyer (eds.)]. IPCC, Geneva, Switzerland, 151 pp.
- Jensen, K.T., 1992. Dynamics and growth of the cockle, *Cerastoderma edule*, on an intertidal mud-flat in the Danish Wadden Sea: effects of submersion time and density. Netherlands journal of sea research, 28(4), pp.335-345.
- Jensen, K.T. & Jensen, J.N., 1985. The importance of some epibenthic predators on the density of juvenile benthic macrofauna in the Danish Wadden Sea. Journal of experimental marine biology and ecology, 89, pp.157-174.
- Jespersen, H. and Olsen, K., 1982. Bioenergetics in veliger larvae of *Mytilus edulis* L. Ophelia, 21(1), pp.101-113.
- Joaquim, S., Matias, D., Matias, A.M., Leitao, A., Soares, F., Cabral, M., Chicharo, L. and Gaspar, M.B., 2016. The effect of density in larval rearing of the pullet carpet shell *Venerupis corrugata* (Gmelin, 1791) in a recirculating aquaculture system. Aquaculture research, 47(4), pp.1055-1066.
- Jonsson, P.R., Andre, C. and Lindegarth, M., 1991. Swimming behaviour of marine bivalve larvae in a flume boundary-layer flow-evidence for near-bottom confinement. Marine ecology progress series, 79(1-2), pp.67-76.
- Jørgensen, C.B., 1946. Lamellibranchia. Meddl. Komm. Dan. Fisk. Havundersøg., Ser. Plankton, 4, pp.277-311.
- Ke, X., Evans, G. and Collins, M.B., 1996. Hydrodynamics and sediment dynamics of The Wash embayment, eastern England. Sedimentology, 43(1), pp.157-174.

### Chapter 3

- Kennington, K. and Rowlands, W., 2006. SEA area 6 Technical report—Plankton ecology of the Irish Sea. Offshore Energy Strategic Environmental Assessment—SEA6 Irish Sea. Department of Trade and Industry. Crown Copyright.
- Kingsford, M.J. et al., 2002. Sensory environments, larval abilities and local self-recruitment. *Bulletin of marine science*, 70(1), pp.309–340
- Kingston, P.F., 1974. Studies on the Reproductive Cycles of *Cardium edule* and *C. glaucum*. *Marine biology*, 28, pp.317–323.
- Kurihara, H., 2008. Effects of CO<sub>2</sub>-driven ocean acidification on the early developmental stages of invertebrates. *Marine ecology progress series*, 373, pp.275–284.
- Lavens, P. and Sorgeloos, P., 1996. Manual on the production and use of live food for aquaculture (No. 361). Food and Agriculture Organization (FAO).
- Lebour, M., 1938. Notes on the breeding of some lamellibranchs from Plymouth and their larvae. *Journal of the marine biological association of the United Kingdom*, 23(01), pp.119–144.
- Lee, J.W., Applebaum, S.L. and Manahan, D.T., 2016. Metabolic Cost of Protein Synthesis in Larvae of the Pacific Oyster (*Crassostrea gigas*) Is Fixed Across Genotype, Phenotype, and Environmental Temperature. *The biological bulletin*, 230(3), pp.175-187.
- Liu, W., Alabi, A.O. and Pearce, C.M., 2008. Fertilization and embryonic development in the basket cockle, *Clinocardium nuttallii*. *Journal of shellfish research*, 27(2), pp.393-397.
- Longshaw, M. & Malham, S.K., 2012. A review of the infectious agents, parasites, pathogens and commensals of European cockles (*Cerastoderma edule* and *C. glaucum*). *Journal of the marine biological association of the United Kingdom*, 93(01), pp.227–247.
- Loosanoff, V.L. and Davis, H.C., 1963. Rearing of bivalve mollusks. *Advances in marine biology*, 1, pp.1-136.
- Malham, S.K., Hutchinson, T.H. & Longshaw, M., 2012. A review of the biology of European cockles (*Cerastoderma* spp.). *Journal of the marine biological association of the United Kingdom*, 92(07), pp.1563–1577.
- Marshall, R., McKinley, S. and Pearce, C.M., 2010. Effects of nutrition on larval growth and survival in bivalves. *Reviews in aquaculture*, 2(1), pp.33-55.
- Martínez-Castro, C. and Vázquez, E., 2012. Reproductive cycle of the cockle *Cerastoderma edule* (Linnaeus 1758) in the Ria de Vigo (Galicia, Northwest Spain). *Journal of shellfish research*, 31(3), pp.757-767.
- Morgan, E., O'Riordan, R.M. and Culloty, S.C., 2013. Climate change impacts on potential recruitment in an ecosystem engineer. *Ecology and evolution*, 3(3), pp.581-594.
- Newell, R.I.E. and Bayne, B.L., 1980. Seasonal changes in the physiology, reproductive condition and carbohydrate content of the cockle *Cardium* (= *Cerastoderma*) *edule* (Bivalvia: Cardiidae). *Marine biology*, 56(1), pp.11-19.
- Norris, K., Bannister, R. & Walker, P., 1998. Changes in the number of oystercatchers *Haematopus ostralegus* wintering in the Burry Inlet in relation to the biomass of cockles *Cerastoderma edule* and its commercial exploitation. *Journal of applied ecology*, 35, pp.75–85.
- Osman, R.W., Whitlatch, R.B. and Zajac, R.N., 1989. Effects of resident species on recruitment into a community: larval settlement versus post-settlement mortality in the oyster *Crassostrea virginica*. *Marine ecology progress series*, pp.61-73.
- Pechenik, J.A., Eyster, L.S., Widdows, J. and Bayne, B.L., 1990. The influence of food concentration and temperature on growth and morphological differentiation of blue mussel *Mytilus edulis* L. larvae. *Journal of experimental marine biology and ecology*, 136(1), pp.47-64.
- Philippart, C.J., Cadée, G.C., van Raaphorst, W. and Riegman, R., 2000. Long-term phytoplankton-nutrient interactions in a shallow coastal sea: Algal community structure, nutrient budgets, and denitrification potential. *Limnology and oceanography*, 45(1), pp.131-144.

### Chapter 3

- Philippart, C.J., van Aken, H.M., Beukema, J.J., Bos, O.G., Cadée, G.C. and Dekker, R., 2003. Climate-related changes in recruitment of the bivalve *Macoma balthica*. *Limnology and oceanography*, 48(6), pp.2171-2185.
- Phillips, N.E., 2002. Effects of nutrition-mediated larval condition on juvenile performance in a marine mussel. *Ecology*, 83(9), pp.2562-2574.
- Platt, T., Fuentes-Yaco, C. & Frank, K.T., 2003. Spring algal bloom and larval fish survival. *Nature*, 423, pp.398-399.
- Pronker, A.E., Nevejan, N.M., Peene, F., Geijssen, P. and Sorgeloos, P., 2008. Hatchery broodstock conditioning of the blue mussel *Mytilus edulis* (Linnaeus 1758). Part I. Impact of different micro-algae mixtures on broodstock performance. *Aquaculture international*, 16(4), pp.297-307.
- Pronker, A.E., Peene, F., Donner, S., Wijnhoven, S., Geijssen, P., Bossier, P. and Nevejan, N.M., 2015. Hatchery cultivation of the common cockle (*Cerastoderma edule* L.): from conditioning to grow-out. *Aquaculture research*, 46(2), pp.302-312.
- Raby, D., Mingelbier, M., Dodson, J.J., Klein, B., Lagadeuc, Y. and Legendre, L., 1997. Food-particle size and selection by bivalve larvae in a temperate embayment. *Marine biology*, 127(4), pp.665-672.
- Robert, R., His, E. and Dinet, A., 1988. Combined effects of temperature and salinity on fed and starved larvae of the European flat oyster *Ostrea edulis*. *Marine biology*, 97(1), pp.95-100.
- Ruppert, E., Fox, R. & Barnes, R., 2004. *Invertebrate Zoology - a functional evolutionary approach* Seventh., Brooks/Cole. pp.367-403.
- SAHFOS - Continuous Plankton Recorder (CPR) Survey. <http://www.sahfos.ac.uk> [accessed December 2016]
- Seed, R. & Brown, R., 1977. A comparison of reproductive cycles of *Modiolus modiolus* (L.), *Cerastoderma* (= *Cardium*) *edule* (L.), and *Mytilus edulis* (L.) in Strangford Lough, Northern Ireland. *Oecologia*, 30, pp.173-188.
- Shumway, S.E. and Parsons, G.J. eds., 2011. *Scallops: biology, ecology and aquaculture* (Vol. 40). Elsevier.
- Sponaugle, S., Cowen, R.K., Shanks, A., Morgan, S.G., Leis, J.M., Pineda, J., Boehlert, G.W., Kingsford, M.J., Lindeman, K.C., Grimes, C. and Munro, J.L., 2002. Predicting self-recruitment in marine populations: biophysical correlates and mechanisms. *Bulletin of marine science*, 70(1), pp.341-375.
- Sprung, M., 1984. Physiological energetics of mussel larvae (*Mytilus edulis*). I. Shell growth and biomass. *Marine ecology progress series*. Oldendorf, 17(3), pp.283-293.
- Talmage, S.C. and Gobler, C.J., 2011. Effects of elevated temperature and carbon dioxide on the growth and survival of larvae and juveniles of three species of Northwest Atlantic bivalves. *PloS one*, 6(10), p.e26941.
- Tiensongrusmee, B. and Pontjoprawiro, s., 1988. *Cockle Culture*, In: FAO Fisheries and Aquaculture Department, Rome. FAO-FI-INS/81/008/MANUAL/12.
- Thomas, F.I., Edwards, K.A., Bolton, T.F., Sewell, M.A. and Zande, J.M., 1999. Mechanical resistance to shear stress: the role of echinoderm egg extracellular layers. *The biological bulletin*, 197(1), pp.7-10.
- Thorson, G., 1950. Reproductive and larval ecology of marine bottom invertebrates. *Biological reviews*, 25, pp.1-45.
- Troost, K., Kamermans, P. and Wolff, W.J., 2008. Larviphagy in native bivalves and an introduced oyster. *Journal of sea research*, 60(3), pp.157-163.
- Tubiash, H.S., Chanley, P.E. and Leifson, E., 1965. Bacillary necrosis, a disease of larval and juvenile bivalve mollusks I. Etiology and epizootiology. *Journal of bacteriology*, 90(4), pp.1036-1044.
- Utting, S.D. and Millican, P.F., 1997. Techniques for the hatchery conditioning of bivalve broodstocks and the subsequent effect on egg quality and larval viability. *Aquaculture*, 155(1), pp.45-54.
- Utting, S.D. and Spencer, B.E., 1991. *The hatchery culture of bivalve mollusc larvae and juveniles* (Vol. 68). Ministry of Agriculture, Fisheries and Food, Directorate of Fisheries Research.

### Chapter 3

- Verween, A., Vincx, M. and Degraer, S., 2007. The effect of temperature and salinity on the survival of *Mytilopsis leucophaeata* larvae (Mollusca, Bivalvia): The search for environmental limits. *Journal of experimental marine biology and ecology*, 348(1), pp.111-120.
- Waldbusser, G.G., Hales, B., Langdon, C.J., Haley, B.A., Schrader, P., Brunner, E.L., Gray, M.W., Miller, C.A., Gimenez, I. and Hutchinson, G., 2015. Ocean acidification has multiple modes of action on bivalve larvae. *PloS One*, 10(6), p.e0128376.
- Walne, P.R., 1970. Studies on the food value of nineteen genera of algae to juvenile bivalves of the genera *Ostrea*, *Crassostrea*, *Mercenaria* and *Mytilus*. *Fisheries investment series*. 2, 26(5).
- Wassnig, M. and Southgate, P.C., 2011. Embryonic and larval development of *Pteria penguin* (Röding, 1798) (Bivalvia: Pteriidae). *Journal of molluscan studies*, 78(1), pp.134-141.
- West, A.D. et al., 2007. Predicting site quality for shorebird communities: A case study on the Wash embayment, UK. *Ecological modelling*, 202, pp.527–539.
- Wehrmann, A., 1999. Long-term survival of epibenthic *Cerastoderma edule* (L.) in bivalve clusters on backbarrier tidal flats, North Sea. *Senckenbergiana Maritima*, 30(1-2), pp.47-61.
- Whitton, T., 2013. Processes controlling spatial and temporal variations in cockle *Cerastoderma edule* (L.) abundance and distribution, Bangor University, pp.123.
- Woolmer, A., Fitzgerald, A., Woo, J., and Wootton, E., 2013. Atypical Cockle Mortality in England & Wales. Review of National Cockle Mortality Issues and Options for Fishery Management in Kent and Essex IFCA, UK.
- Yankson, K., 1986. Reproductive cycles of *Cerastoderma glaucum* (Bruguiere) and *C. edule* (L.) with special reference to the effects of the 1981–82 severe winter. *Journal of molluscan studies*, 52(1), pp.6-14.
- Yankson, K. and Moyse, J., 1983. Artificial fertilization and rearing of *Cerastoderma lamarcki* (Reeve) in the laboratory. *Journal of Molluscan Studies*, 49(supp12A), pp.209-213.
- Yund, P.O. and McCartney, M.A., 2016. Family effects on the growth and survival of congeneric blue mussel larvae (*Mytilus edulis* and *M. trossulus*). *Marine biology*, 163(4), pp.1-12.



## **Spatial and seasonal variation of the parasite and pathogen communities found in *Cerastoderma edule* (L.) from two locations in North Wales, United Kingdom**

### **4. Abstract**

Populations of *Cerastoderma edule* are known to host many different parasites, pathogens and diseases. The physiological effect of infection to the host can vary between species, from no affect to large scale parasite induced mortality events. This study takes a seasonal approach to two economically important natural cockle fisheries in North Wales. To assess the spatial and temporal variability of infection, samples of cockles were collected four times over a 1-year period between 2014 – 2015. Sampling took place at two sites (Dee estuary and Traeth Melynog), each site divided into two beds. Cockle samples were processed by histological techniques and screened for the different parasites, pathogens and diseases. Analysis of 30 individuals from each sampling period revealed the presence of 17 different groups of parasites (Dee estuary = 15; Traeth Melynog = 16), of which, 6 groups are known to have a direct or indirect effect on the overall health of its host: digeneans *Bucephalus* spp., *Gymnophallus* spp. and *Himasthla* spp.; haplosporidans *Haplosporidium* spp. and *Minchinia* spp. and the virus Haemocytic neoplasia. An analysis of similarities (ANOSIM) on the community structure of the different groups was shown to be significantly different between sites and a SIMPER analysis showed *Paravortex* spp. to contribute most to this observed dissimilarity between sites. No differences between the sampling seasons were observed when tested independently. Within site differences were also not observed between seasons or beds. The results highlight some pathological response to infection. Six groups of parasites and pathogens identified as most important to the fisheries are discussed in relation to their life-history and associated mortality.

### **4.1.1 Introduction**

*Cerastoderma edule*, the edible cockle, is known to host many different species of parasites and diseases, which can be highly prevalent and abundant within individuals and populations (Lauckner, 1983; de Montaudouin et al., 2000; Thieltges, 2006; Longshaw and Malham, 2013). Although the parasites and diseases of cockles have been extensively studied, their direct impact on the cockle's health is relatively unknown. It is acknowledged that any negative effects to the host can be amplified by unfavourable environmental factors (Magalhães

et al., 2018). By increasing the stress placed upon its host, or by taking advantage of the hosts weakened state, parasitic infections can contribute towards individual mortality and potentially atypical mass-mortality events at a population level (Jonsson & André, 1992; Longshaw and Malham, 2013; Woolmer et al., 2013; Burdon et al., 2014). Parasites themselves play a functionally important role and are considered a biotic force influencing a communities' biodiversity and its structuring across several levels (Lauckner, 1984; Poulin, 1999; Mouritsen & Poulin, 2002). For example, in *Austrovenus stutchburyi*, the New Zealand cockle which is found along the coast of New Zealand, heavy infections by the metacercarial stages of the trematode *Curtuteria australis*, are known to reduce *A. stutchburyi*'s burrowing ability with heavily infected individuals more prone to predation (Poulin, 1999). Infection of *C. australis* can also have an indirect effect on the community of epibionts which can be found attached to the shells of *A. stutchburyi*. The reduction in the burrowing ability of *A. stutchburyi*, increases the duration of time their shells are exposed out of the sediment, and provides an opportunity for other organisms to attach onto their shells. For example, unburied *A. stutchburyi* are found to have a greater number of limpets attached to their shells compared to those who are not restricted in their burrowing capabilities. *A. stutchburyi* which are unaffected by *C. australis* infection may have a greater number of anemones attached to their shells. Anemones are known to predate on limpets and thus restrict the numbers of limpets found on *A. stutchburyi*. Anemones are also less tolerant to prolonged exposure to air and cannot survive in unburied conditions during low tidal periods (Poulin, 1999). Effects on the parasite community in *A. stutchburyi* can also be observed as a result of reduced burrowing ability of the cockle, as these individuals are five times more likely to host another trematode species, *C. pectinata* (Poulin, 1999). Dabouineau and Ponsero (2009) also found a high infestation of metacercariae (cysts) from *Himasthla* spp. present in "surfaced" *C. edule* from the bay of Saint-Brieuc, in France. It is this connectivity between the parasites and their direct and indirect effect to the host and non-host species, which make parasites a key part of the biota to the community in which they are found (Bush et al., 1997).

*Cerastoderma edule* plays an important role in the complex life cycle of some marine parasites. For example, they can act as either the first and/or second intermediate hosts to larval stages of digenean trematodes, with mature adult stages of the parasite occurring in final hosts such birds and fish (Chapter 1, Fig. 2). As the parasite's main goal is to mature and reproduce, it is not in its interest to cause direct mortality to its host. A strategic approach appears to be to weaken the individual, making it susceptible to predation; a phenomenon called the

“favourisation” mechanism (Rohde, 1993; Combes, 1996; Dabouineau and Ponsero, 2009). The levels of parasitic infection within hosts is partly determined by the environment, its seasonal fluctuations and by the population dynamics of the hosts (Presta et al., 2014). For example, temperature is an important component in driving parasite transmission and the biological effects parasites have on the host. Increased temperatures due to climate change may disrupt the balance of the parasite-host relationships and potential negative effects on the populations could become apparent (de Montaudouin et al., 2009). Any extra pressures placed on cockle stocks, either environmental or through managed fisheries, could threaten cockle population; increasing the impact of parasites on host survivability.

So far, around 50 species of parasites, pathogens and commensals have been identified in *C. edule* throughout its distributional range. Of these, 11 have been reported to have a population level effect and have been linked to mass mortalities; 5 have an effect at the individual level, either contributing towards mortality or impacting growth and metabolism; 10 have localised pathology and the effect on the individual is considered low; and the remaining 24 have little or no effect to their host (Longshaw and Malham, 2013). Species of most concern belong to the following taxonomic groups: Digenea (*Bucephalus* spp. and *Gymnophallus* spp.); Haplosporidia (*Haplosporidium* spp., *Minchinia* spp. and *Bonamia* spp.); Cercozoa (*Marteilia conchilia*); and various bacteria and viruses (Reece et al., 2004; Longshaw and Malham, 2013; Lynch et al., 2013).

Few parasitological surveys have investigated the parasite community found in *C. edule* over an extended spatial and temporal scale (Carballal et al., 2001; Thielges and Reise, 2006; de Montaudouin et al., 2009; Fermer et al., 2010). Much of the research has focused upon digenean species or on macroparasites as they are visible to the naked eye, thus removing the need for advanced screening techniques (Fermer et al., 2010). The use of histology techniques to examine the structure of cells, tissues and organs in *C. edule*, can provide detailed information on the microscopic changes due to infection from viruses, bacteria and protists that would otherwise be missed through standard screening procedures. Histology can therefore help to provide a comprehensive assessment, at a population level, of the pathological response of *C. edule* to a wide range of infections, as well as providing additional contemporaneous data such as reproductive state and evidence of non-disease derived pathologies. In consequence, a degree of technical competence (a high level of knowledge is required to interpret the tissue sections and the pathological response) and availability to the specialist equipment needed for processing the tissue samples.

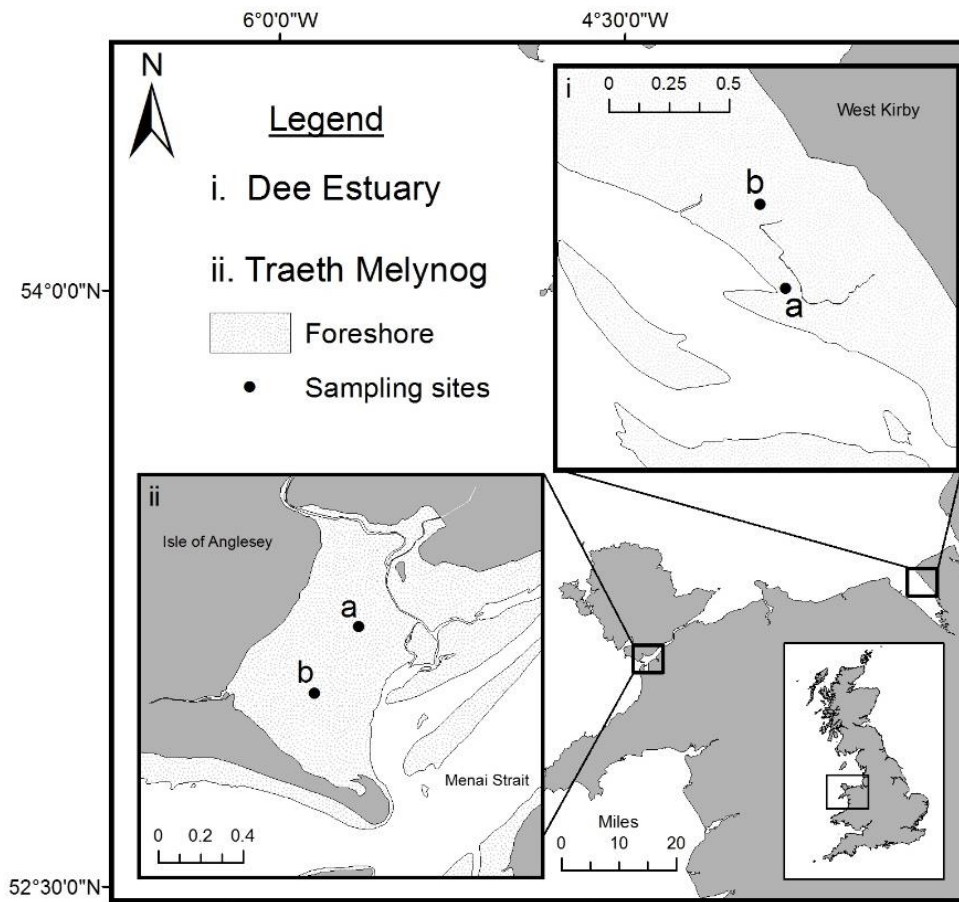
### 4.1.2 Aims and Hypotheses

To preserve and enhance the commercial viability of cockle stocks in North Wales, it is essential to understand the biotic stressors that influence cockle populations at a localised and, more widely, at a population level. The main aim of this study is to investigate the spatial and temporal variability of the parasite and pathogen fauna of *C. edule* from two fisheries in North Wales, UK. By comparing two distinctly different cockle fisheries, in terms site characteristics (Chapter 1, 1.6), this study's hypotheses are that over the course of a year, there are differences in the community of parasites, pathogens and diseases between each fishery. It also aims to detect if differences occur at a smaller spatial scale by comparing two sampling locations within each fishery and whether the time of year, e.g. the season, also controls the community we see. This study also aims to create a detailed inventory, specific to the North Wales cockle fisheries, of microorganisms present in *C. edule* that can be used as baseline data for future research. Lastly, it sets out to identify specific groups of microorganisms that may be cause for concern to the overall health of the cockle fisheries due to associated pathology on the host.

## 4.2 Methods and Materials

### 4.2.1 Collection locations

*Cerastoderma edule* were collected at low tide from two intertidal mudflats at West Kirby in the Dee Estuary and at Traeth Melynog on the southern end of the Menai Strait, Isle of Anglesey (Fig. 1). Sites were selected to represent two populations that experience different levels of fishing pressure, on their accessibility and safety, and for the availability of *C. edule* in high densities.



**Figure 1.** Location of sites used in the collection of *Cerastoderma edule* for the screening of parasites and pathogens between autumn 2014 and autumn 2015.

The Dee estuary, one of the top four cockle producing estuaries in Great Britain, is home to a large scale, highly valuable commercial cockle fishery and represents a population subject to heavy fishing pressure. The whole estuarine area receives special status through its multiple designations which include but is not limited to: The Dee Estuary Special Protected Area (SPA), designated for its importance to wading birds, and; The Dee Estuary Special Area

of Conservation, for the important coastal habitats present. In comparison, Traeth Melynog is on a much smaller scale in terms of total area, cockle biomass and level of fishing activity.

#### 4.2.2 Sampling

Sampling of *Cerastoderma edule* was designed to provide between site and within site information on the parasite and pathogenic communities present in the fisheries. Historic fishery survey data helped to determine the distribution of cockles within each fishery and, in combination with preliminary surveys, assisted in setting the permanent sampling locations, which would be revisited over the year (data sourced from Natural Resources Wales and Bangor University). Each site was visited four times between the autumn of 2014 and the autumn of 2015 (corresponding to 3-4-month intervals between the sampling periods). Sampling times coincided with the general seasons found in the temperate climate of the UK (Table 1). Each site was arbitrarily divided into two beds, A and B. The distance between these beds was approximately 600 m and lay along the mid shoreline. To keep consistency in the methods for collecting cockles across each sampling season, cockles were selected from five randomly placed 0.1 m<sup>2</sup> quadrats within a 10-metre radius of the fixed GPS position. Previous experience collecting cockles from Traeth Melynog and the Dee estuary (for broodstock collection in Chapter 3) showed that cockle mortality is high when removed from their natural habitat and kept in aquaria. Collecting cockles from five quadrats ensured enough cockles were collected, so after initial mortality between the sampling and processing time, the minimum number ( $n=30$ ) required for the analysis could be met. The sediment inside each quadrat was excavated with a small trowel down to a depth of 5 cm and washed through a 1 mm sieve. Cockles were checked to determine that they were living by applying force on each shell valve to gently prise open the shell and inspect the presence of the mantle along the shell edge. All living cockles present in the sieve were placed in clear plastic bags and transported back to the laboratory on ice. On arrival at the laboratory, the cockles from each quadrat were sorted into size classes based on shell lengths (SL) of: <10 mm; 10-20 mm; >20 mm and placed into 50 L holding tanks at densities no greater than 50 individuals per tank – equivalent to <200 m<sup>-2</sup> – where they received a continuous flow of seawater at an approximate rate of 1 L/min<sup>-1</sup>. They remained in the holding tanks until processing the following day to reduce unnecessary mortality.

**Table 1.** Location and date of the sampling periods (dd/mm/yyyy). Dee = Dee estuary; TM = Traeth Melynog.

Site	Fixed GPS position	Autumn 2014	Winter 2014/15	Spring 2015	Summer 2015
DEE A	53.35641 N 03.18817 W	26/10/2014	17/02/2015	10/06/2015	21/09/2015
DEE B	53.36142 N 03.19085 W	26/10/2014	17/02/2015	10/06/2015	21/09/2015
TM A	53.140051 N 04.3314204 W	22/10/2014	10/02/2015	11/05/2015	23/09/2015
TM B	53.135417 N 04.3361629 W	22/10/2014	10/02/2015	11/05/2015	23/09/2015

### 4.2.3 Environmental parameters (Temperature loggers)

Between September 2014 and October 2015, temperature loggers (Onset Tidbit v2) recorded the temperature of the sediment at a depth of 5 cm, based on the normal burrowing depth of *C. edule* during low tidal periods (Caraway et al., 2013), every 30-minutes. This was achieved by fixing the loggers to 1-meter long metal rods that were hammered into the sediment, thus preventing any movement initiated from wave and tidal action. The rods were located along an equal shoreline at approximately equidistant between each of the sampling locations (beds A & B). An accurate GPS position of each rod was recorded to assist in the recovery of the temperature loggers. During each site visit, the temperature loggers were removed from the sediment and the data downloaded. Afterwards, they were reset and replaced back into the sediment to continue recording the temperature.

### 4.2.4 Sample preparation

To prepare the cockles for histological processing, all cockles collected from each sampling period were removed from the holding tanks, then washed and scrubbed with fresh seawater to remove any epifauna from the shells. Depending on the total number of cockles collected from each site (due to variation in the densities of cockles across the seasons), either all cockles present in the holding tanks or a maximum of twenty cockles from each size class ( $n=60$ ) from each bed were randomly selected for dissection and processing. This would ensure

that enough were dissected and sent for processing to cover i) the number of cockles required for analysis ( $n=30$ ) and ii) to provide enough samples onto slides for familiarisation of the different microorganisms found within *C. edule*. On occasions when twenty cockles from each size class could not be met, individual cockles from the other size classes were used to make up the numbers required.

Each cockle was blot dried using paper towel and the wet weight in grams of the whole animal (including shell) was recorded to the nearest 3 decimal places. Shell Length (SL), Shell Height (SH) and Shell Width (SW) were measured to the nearest 0.01 mm using Moore and Wright digital callipers (model 110-DBL,  $\pm 0.03$  mm accuracy). A scalpel gently prised apart the two valves of the shell and severed the adductor muscles, opening the cockle and exposing the tissue. A razor blade was used to section each cockle into two halves directly down the medial line of the foot. One-half of the cockle was placed into a histology cassette and put into Davidson's seawater fixative (Table 2) (Howard et al., 2004). The other half was placed into a 2 ml Eppendorf tube, then flash frozen in liquid nitrogen and stored at  $-80$  °C for future biochemical analysis. When the tissue sample was deemed too small for sectioning (generally for individuals  $< 10$  mm SL), the whole cockle, including shell and soft tissue, was included. The cassettes remained in Davidson's seawater fixative for 48 hr at  $4$  °C to allow for full tissue penetration of the fixative. Afterwards, the cassettes were removed from the fixative and transferred into a mixture of Industrial Denatured Alcohol (IDA) and distilled water (ratio of 7:3) until processed for histology.

**Table 2.** Recipe used for making up Davidson's seawater fixative. To be added in order of list. The volume of solution adjusted depending on quantity of fixative required (Howard et al., 2004).

Solution	Parts
Glycerol	1
Ethanol (99.5%)	3
Formaldehyde (37%)	2
Seawater (filtered at ambient temperature)	2
Acetic Acid (added before the samples)	1



#### 4.2.5 *Histological analysis*

Histology processing was performed at the Centre of Environment, Fisheries and Aquaculture Science (Cefas), Weymouth, United Kingdom laboratory. Individual cockles, smaller than 10 mm that were fixed whole in their shells, were decalcified using 10 % calcium disodium versenate until the decalcification process was complete (Howard et al., 2004). Samples were processed using a Leica Peloris tissue processor, which took place at ambient temperature following established protocols for molluscan tissue. In brief, samples were dehydrated in Industrial Denaturated Alcohol (IDA) at increasing concentrations (70-100%) for 6 x 30 min cycles then transferred to Leica sub X hydrocarbon solution for another 4 cycles of 45 min (Table 3). Following dehydration, samples were embedded into wax blocks (Table 3). A Thermo Fisher Finnesse microtome was used to cut 3 µm thick sections through the embedded tissue until a cross section containing a representation of the organs was achieved in one section. The tissue sections were floated in a water bath and picked up onto glass slides. These were dried on a hotplate and stained with haematoxylin and eosin using a Gemini Automated Slide Stainer (Thermo Fisher Scientific (Table 4). A single slide from each cockle sample was returned from CEFAS for subsequent screening.

**Table 3.** Processing schedule for the Leica Peloris tissue processor

<b>Processing Steps</b>	<b>Duration (minutes)</b>
70% Industrial Denatured Alcohol	30
90% Industrial Denatured Alcohol	30
100% Industrial Denatured Alcohol	30
100% Industrial Denatured Alcohol	30
100% Industrial Denatured Alcohol	30
100% Industrial Denatured Alcohol	30
Hydrocarbon solvent	40
Hydrocarbon solvent	40
Hydrocarbon solvent	40
Hydrocarbon solvent	40
Wax	45
Wax	45
Wax	45

**Table 4.** Schedule for Haematoxylin and Eosin tissue staining using Gemini Automated Slide Stainer

<b>Stainer Steps</b>	<b>Duration (minutes)</b>
Hydrocarbon solvent	3
Hydrocarbon solvent	3
100% Industrial Denatured Alcohol	3
100% Industrial Denatured Alcohol	3
Water bath	2
(Gill 3) Haematoxylin rinse	10 (seconds)
(Gill 3) Haematoxylin	3
Water bath	6
0.5% Hydrochloric acid alcohol	3 (seconds)
Water bath	6
Thermo alcoholic eosin Y	3
Water rinse	30 (seconds)
70% Industrial Denatured Alcohol	30 (seconds)
100% Industrial Denatured Alcohol	3
100% Industrial Denatured Alcohol	3
100% Industrial Denatured Alcohol	3
Hydrocarbon solvent	3
Hydrocarbon solvent	3
Hydrocarbon solvent	3

4.2.6 Parasite Screening

The screening of slides for parasites was performed at the laboratories at Bangor University. Out of a total of 814 cockles that were fixed and sent to CEFAS for processing, 802 were successfully processed and returned on slides (Table 5). The 12 samples that were not returned were not able to be processed due to either being absent in the histology cassette (when the tissue sample was too small and did not stay in the histology cassette during the fixing process), or when the sample did not section, usually as a result of the dissection. All 802 slides were screened for the presence of parasites, pathogens and tissue alterations using light microscopy (Meiji microscope, attached with a Lumenera, INFINITY 3 camera and running Image Pro Premier 9.1 software, Media Cybernetics). An initial low power scan of the whole cockle section was performed to assess the overall health status of the cockle and to confirm the different tissue types present within each section. Using higher magnification, each tissue / organ identified was individually searched using a transect pattern to ensure full coverage. The presence of each type of microorganism or tissue alteration, and its location within the host, were recorded in an Excel spreadsheet. Where possible, the maturation stage of each cockle was recorded, and the data is presented in the appendix. Images captured from the camera recorded each occurrence of the identified microorganism. These were subsequently used to quality check the initial identification and to provide further information on the microorganism observed.

**Table 5.** Number of cockles per sampling period that were returned onto slides from the histology processing.

Dee Estuary								Traeth Melynog							
Bed A				Bed B				Bed A				Bed B			
Autumn	Winter	Spring	Summer	Autumn	Winter	Spring	Summer	Autumn	Winter	Spring	Summer	Autumn	Winter	Spring	Summer
44	42	60	60	35	33	60	60	34	49	60	60	38	47	60	60

**Total = 802**

**30 random cockles selected from each sampling period. Total = 480**

### 4.2.7 Statistical Analysis

The survey was designed to detect spatial and temporal variation in parasite and pathogen community structure between the Dee estuary and Traeth Melynog. Subsamples of 30 cockles from each sampling period, were randomly selected from the data on the parasite and pathogen groups obtained through the screening of slides (Table 5). This gave a total of 480 samples (out of the 802 which were screened) that were used in the analysis. The percentage of infection within the population was calculated by taking the number of individuals of a host species ( $n$ ) that were infected with each of the parasite or pathogen groups in each sampling period, divided by the number of hosts examined (30) and multiplied by 100. Standardisation of the dataset was performed to i) take into account the variation of the prevalence in the data (due to the large prevalence of the same groups across the seasons), ii) account for groups which had a low prevalence within the populations and iii) to reduce the effect of groups which are common across all variables that would otherwise mask rarer groups. Therefore,  $n$  was square root transformed prior to the statistical analysis. The parasite and pathogen community data were analysed as a multivariate dataset with the response variable being the percentage of infection (prevalence) and the explanatory variables consisting of three fixed factors; site (two levels: Dee estuary & Traeth Melynog), bed (nested within site consisting of two levels: A & B) and season (four levels: autumn, winter, spring, summer). A similarity matrix was calculated from the transformed data using the Bray-Curtis similarity coefficient (Bray and Curtis, 1957) to quantify the similarity between factors and was expressed as:

$$S_{jk} = 100 \left\{ 1 - \frac{\sum_{i=1}^n |y_{ij} - y_{ik}|}{\sum_{i=1}^n (y_{ij} + y_{ik})} \right\}$$

Where:  $y_{ij}$  = abundance of parasite or pathogen in  $i$  in sample  $j$

$y_{ik}$  = abundance of parasite or pathogen in  $i$  in sample  $k$

$n$  = is the total number of samples

Resemblance between each factor level was observed using multi-dimensional scaling (MDS) to map the position of each data point (in terms of site and bed and seasonal variation), in relation to the other data points in the analysis, in a two-dimensional space. An Analysis of

Similarities (ANOSIM) was used to test whether statistical differences between two of the explanatory variables are found. The null hypothesis of ANOSIM is that there is no significant difference between the parasite and pathogen community across the factor levels. It assumes that the average of rank dissimilarities between objects within groups is equal to the average of rank dissimilarities between objects between groups (Clarke, 1993). ANOSIM produces a test statistic (R value), ranging from -1 to 1. An R value of 0 indicates the null hypothesis is true, above 0 indicates dissimilarity between groups exists (Clarke & Warwick 2001).

ANOSIM is expressed as:

$$R = \left( \frac{\bar{r}_B - \bar{r}_W}{(M/2)} \right)$$

Where:  $\bar{r}_B$  = average rank of similarities of pairs of samples originating from different sites

$\bar{r}_W$  = average rank of similarity of pairs among replicates within sites

$$M = n(n - 1)/2$$

Where:  $n$  = number of samples

To investigate which parasite and pathogen groups are influencing each of the pairwise comparison of the explanatory variables, a SIMPER analysis was performed. SIMPER is based on the decomposition of Bray-Curtis dissimilarity index and calculates the average contribution of each parasite and pathogen group to the average overall Bray-Curtis dissimilarity. The larger this value, the more the group contributes to any differences. SIMPER also generates a ratio of the average contribution of each parasite and pathogen group ( $\delta_i$ ) divided by the standard deviation of that group. Larger ratio values indicate good discriminating groups between the two explanatory variables compared (Clarke & Warwick 2001).

Sediment temperature data recorded by the temperature loggers was standardised by taking the average daily temperature and the maximum and minimum temperatures for each day. Differences between average daily temperatures of the two sites was then calculated by subtracting one from the other. All standardised temperature data was used to visualise the change in temperature over time from each site. A multiple linear regression model compared the relationship between the response variable (average daily temperature) against the interaction of the explanatory variables: month (12 levels) and site (2 levels).

## Chapter 4

The model is expressed as:

$$y = b_0 + b_1x_1 + b_2x_2 + b_3x_1x_2$$

Where:  $y$  = predicted value of the response variable

$b_0, b_1, b_2, b_3$  = regression coefficients

$x_1, x_2, x_1x_2$  = explanatory variables and the interreaction

An Analysis of Variance (ANOVA) (Chapter 3) was then run on the model output to check for significant differences between the independent variables.

All statistical analysis was performed using *RStudio* (version *1.1.419*) and the *vegan* package for *RStudio* was used for the ANOSIM and SIMPER analysis.

### 4.3 Results

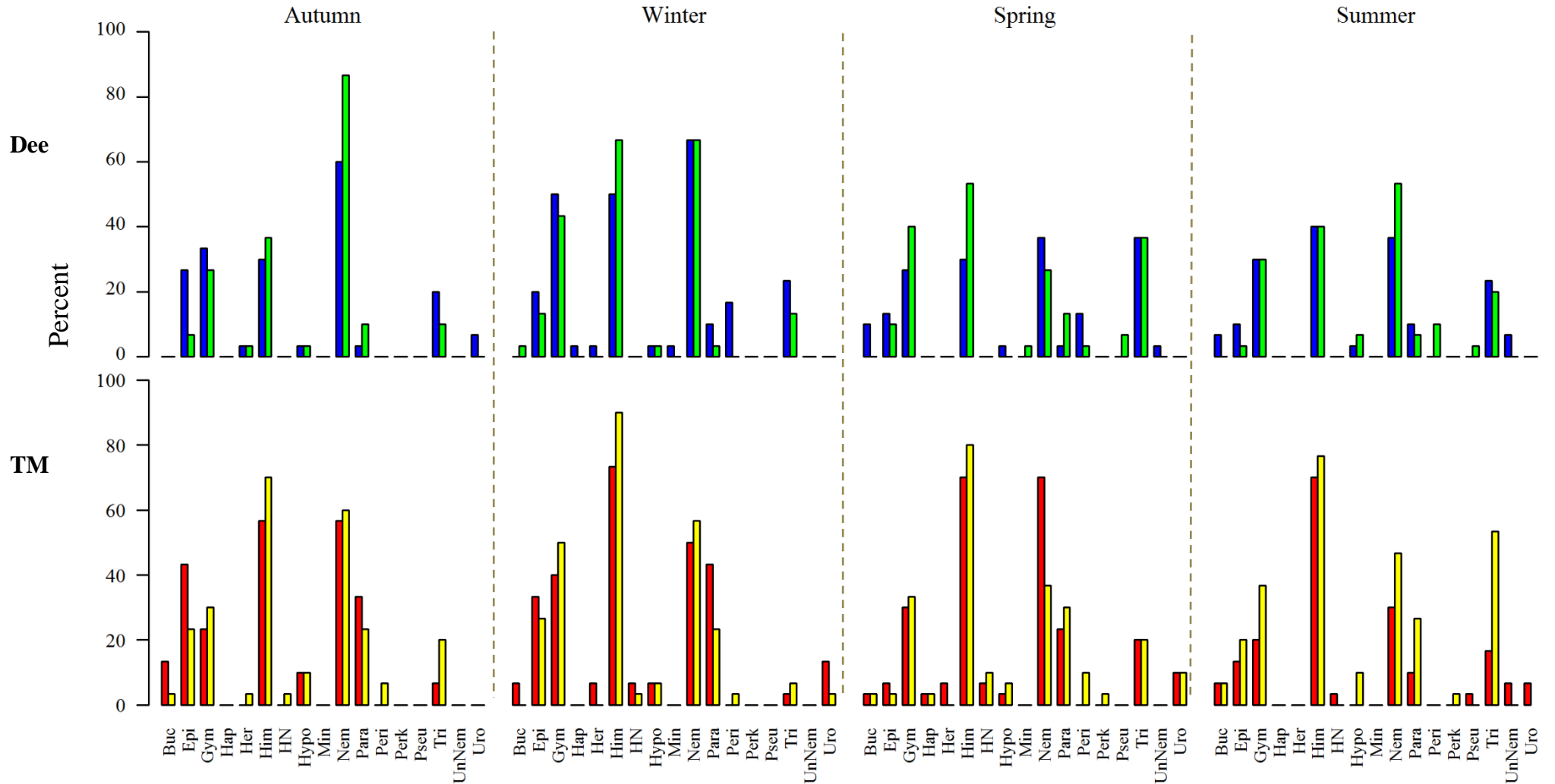
#### 4.3.1 Parasite and pathogen community assemblage

All parasites and pathogens identified during the screening process were categorised into different phylogenetic groups that was determined by the level of identification made possible. No attempt was made to discriminate between closely related species of digeneans within the genera *Himasthla*, *Gymnophallus* and *Bucephalus*. Within the subsampled data, this totalled to 17 groups, which were used for assessing the community structure (Table 6). The percentage of infection and the different groups present at each site is presented in figure 2.

**Table 6.** Summary of the parasitic and pathogenic groups identified, and the tissue location observed found within *Cerastoderma edule*. Ft = foot, Mt = Mantle, Gi = Gill, Go = Gonad, Dg = Digestive gland, In = Intestines, Ki = Kidney, Am = Adductor muscle, Ct = Connective tissue and Tbh = tissue behind hinge

Group Name	Taxa	Tissue	Code
<i>Bucephalus</i> spp.	Digenea	Gi, Go, Dg, Ct	Buc
Epitheliocystis	Bacteria	Ft, Gi, Go, Dg	Epi
<i>Gymnophallus</i> spp.	Digenea	Mt, Gi, Go, Ct, Tbh	Gym
Haemocytic neoplasia	Virus	Ft, Gi, Dg, Ct	HN
<i>Herrmanella</i> spp.	Crustacea	Mt, Go, Ct, Am	Her
<i>Himasthla</i> spp.	Digenea	Ft, Mt, Gi, Go, Dg	Him
<i>Hypocomella</i> spp.	Ciliophora	Mt, Gi	Hypo
<i>Haplosporidium</i> gen. spp.	Haplosporidia	All	Hap
<i>Minchinia</i> spp.	Haplosporidia	Gi, Go	Min
<i>Nematopsis</i> spp.	Apicomplexa	All	Nem
<i>Paravortex</i> spp.	Tubellaria	Dg, In	Para
Peritrichous ciliates	Ciliophora	Mt, Gd, Ct	Peri
<i>Perkinsus</i> spp.	Perkinsozoa	Ki	Perk
<i>Pseudoklossia</i> spp.	Apicomplexa	Ki	Pseu
<i>Trichodina</i> spp,	Ciliophora	Ft, Mt, Gi, Ct, Am	Tri
Unidentified nematode spp.	Nematoda	Mt, Gi	UnNem
<i>Uronema</i> spp.	Ciliophora	Ct	Uro

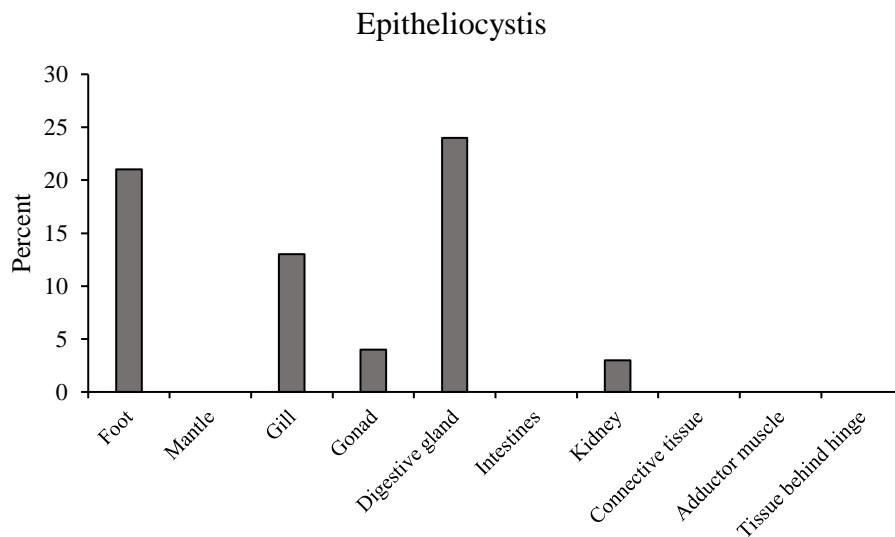




**Figure 2.** Percentage of *Cerastoderma edule* ( $n=30$ ) infected with each of the parasite and pathogen groups, observed in the histology tissue sections, from each sampling season. Samples taken from the Dee Estuary (top row) and Traeth Melynog (bottom row); blue and red bars = bed A, green and yellow bars = bed B. See table 6 for full group name. Groups displayed in alphabetical order.

### **Bacteria**

Epitheliocystis (bacterial cysts), caused by either *Rickettsia*- or *Chlamydia*-like bacteria, were present at all locations during each sampling period (Fig. 2). They occurred in 17% ( $n=82$  of 480) of cockles examined, of which, 62% ( $n=51$  of 82) of came from Traeth Melynog. Prevalence of these bacterial cysts in cockles sampled in the autumn and winter months (35%;  $n=28$ ) was more than twice the prevalence in cockles sampled in the spring and summer. The most prevalent – twenty-four percent ( $n=13$ ) of the cockles from Traeth Melynog in the autumn showed signs of this infection. Of the 82 individuals infected, the epithelial cells of the mantle were the most common location for this pathogen, occurring in 44% ( $n=35$ ) of those infected. Other tissues include the digestive gland at 24% ( $n=19$ ) (Fig. 7.a), the foot at 21% ( $n=17$ ), the gill at 13% ( $n=10$ ), the gonads and intestines at 4% ( $n=3$ ), and the kidneys at 3% ( $n=2$ ) prevalence (Fig. 3).

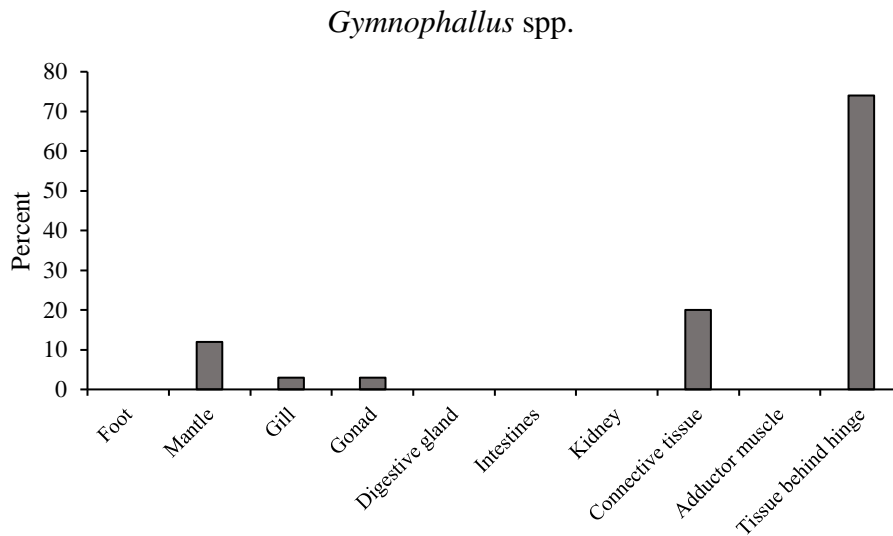


**Figure 3.** Percentage of occurrence for each tissue type identified in *Cerastoderma edule* infected with Epitheliocystis ( $n=82$ ).

### **Digenea**

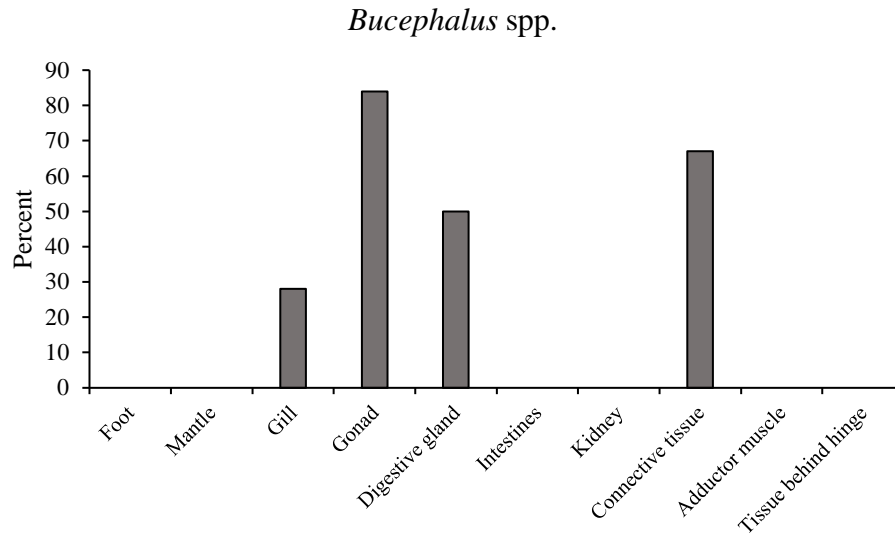
Of the digeneans recorded, those belonging to the genus *Gymnophallus* occurred in 34% ( $n=163$  of 480) of the cockles with an almost equal split between the Dee Estuary and Traeth Melynog at 51% & 49% ( $n= 84$  &  $79$ ) (Fig. 2). Of the 163 cockles observed to host *Gymnophallus* spp., 74% ( $n=119$ ) contained this parasite in the tissue behind the hinge, often referred to as the pouch (Fig. 4 & Fig. 7b ). *Gymnophallus* spp. were also found in the mantle for 12% ( $n=20$ ), 3% for both the gill and gonad ( $n=4$ ), and 20% ( $n=32$ ) in the connective tissues

or an unidentified location (Fig. 4). There was no obvious pathological response in any individual cockle infected with *Gymnophallus* spp.



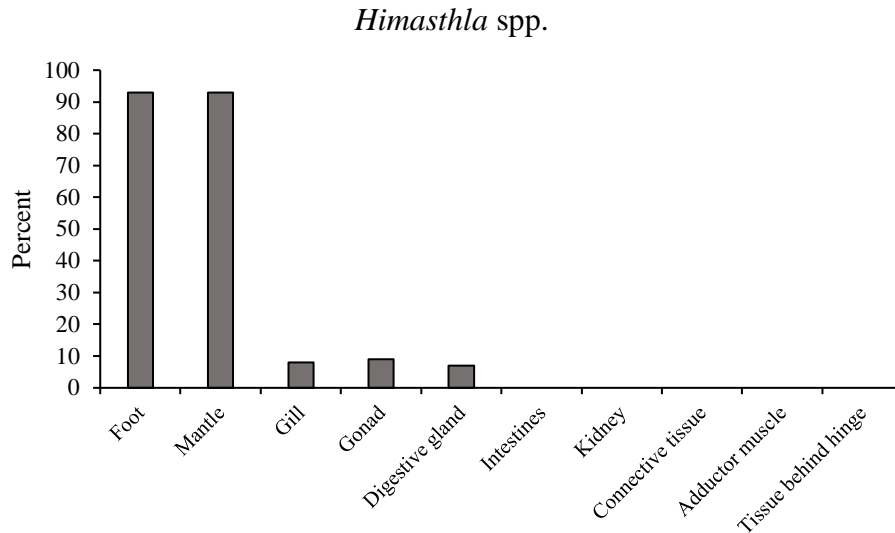
**Figure 4.** Percentage of occurrence for each tissue type identified in *Cerastoderma edule* infected with *Gymnophallus* spp. ( $n=163$ ).

Another digenean, *Bucephalus* spp. was observed in 4% ( $n=19$  of 480) of the cockles sampled. 68% ( $n=13$  of 19) of those infected with *Bucephalus* spp. came from Traeth Melynog where the parasite was present across all seasons (Fig. 2). The most common tissue found to contain *Bucephalus* spp. was the gonad, 84% ( $n=16$  of 19) (Fig. 5), of which, seven were identified as female, one male, and the remaining eight could not be determined. This was likely to have been due to complete castration as a result of infection (Fig. 7.c). All but a single cockle had a shell length greater than 20 mm. Other tissue where *Bucephalus* spp. was also observed included the digestive gland for 50% ( $n=9$ ), and the gill for 28% ( $n=5$ ). 67% ( $n=12$ ) of the cockles infected contained the parasite in connective tissues or in locations not identifiable (Fig. 5). Both sample sites contained sporocyst and cercarial stages of *Bucephalus* spp. It was not possible, however, to identify whether these belonged to the same species. *Bucephalus* spp. did not present any significant difference in the prevalence of infection between sites.



**Figure 5.** Percentage of occurrence for each tissue type identified in *Cerastoderma edule* infected with *Bucephalus* spp. ( $n=19$ ).

Pearl forming metacercaria, most likely belonging to the genus *Himasthla*, was present in 59% ( $n=280$  of 480) of the samples (Fig. 7.d) and was the most common parasite present in this study (Fig. 2). Between the two sites, 63% ( $n=176$  of 280) of the cockles infected with *Himasthla* spp. came from Traeth Melynog. Of the 280 cockles infected, 93% ( $n=261$ ) were found in the mantle and/or foot tissues. *Himasthla* spp. metacercaria were also identified in the gonads in 9% ( $n=26$ ), the digestive gland 7% ( $n=20$ ), and in around 8% ( $n=22$ ) for the gill, connective tissues, intestines and kidney combined (Fig. 6). In 7% ( $n=20$ ) individuals, the presence of *Himasthla* induced an inflammatory response to the surrounding tissue.

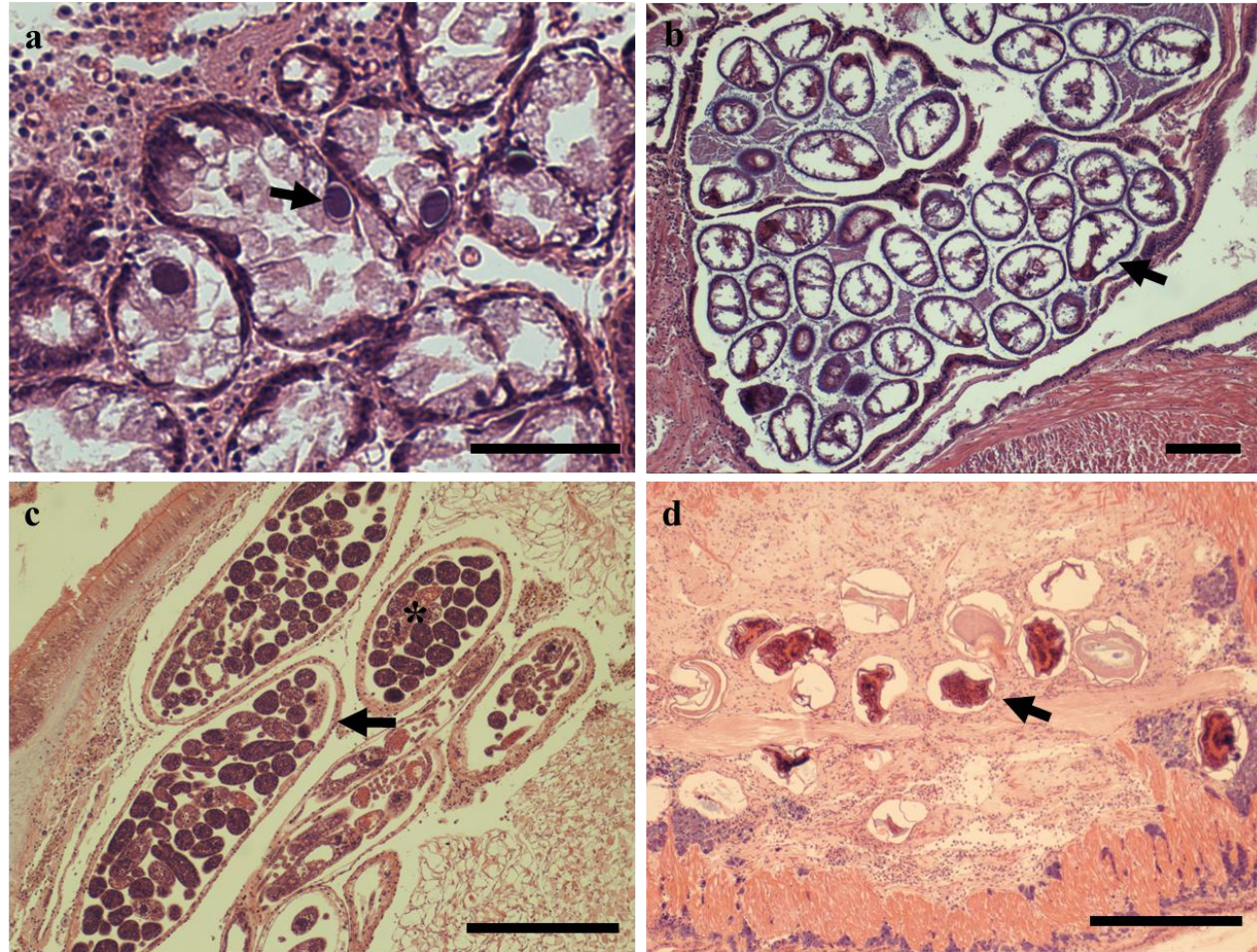


**Figure 6.** Percentage of occurrence for each tissue type identified in *Cerastoderma edule* infected with *Himasthla* spp. ( $n=280$ ).

### *Haplosporidia*

Two different haplosporidian were recorded in the samples at low prevalence. The first belonging to the *Haplosporidium* spp. group was identified in <1% ( $n=3$  of 480) of the total samples, but present in both sites. It was found in one individual from the Dee estuary during the winter sampling, and two individuals from Traeth Melynog during the spring sampling (Fig. 2). Infection was restricted to the digestive gland and gonad in the Dee individuals (Fig. 10.a), whereas, one of the cockles from Traeth Melynog had a high level of infection with developing spores in the plasmodia of all tissue types throughout the section.

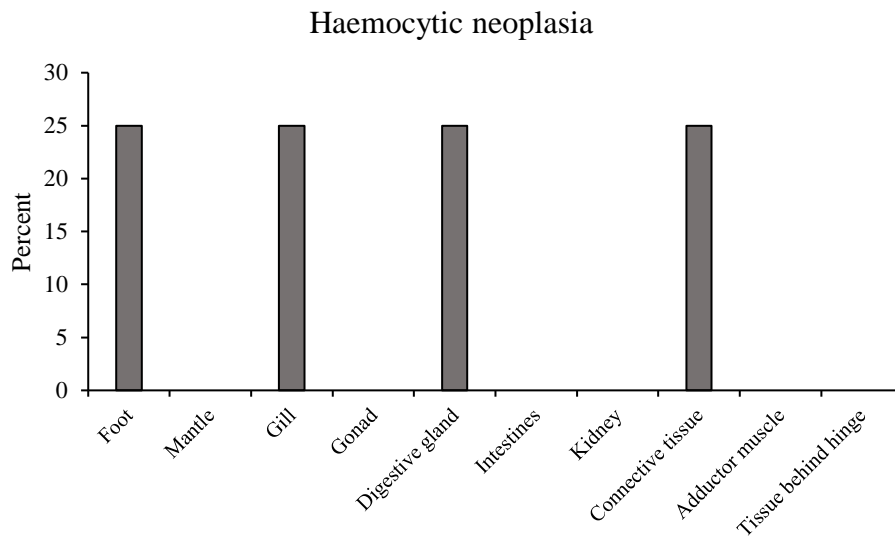
The other haplosporidian was likely to have belonged to the genus *Minchinia* and was found in two individuals from the Dee estuary: one in winter and one in spring (Fig. 2). *Minchinia* spp. was present in the gill and digestive gland tissues and was difficult to identify as infection also coincided with heavy haemocytic infiltration (Fig. 10.b). Some evidence of *Minchinia* spp. infection was also observed in cockles screened from Traeth Melynog, but these cockles were not randomly selected for the subset of 30 individuals used in the statistical analysis.



**Figure 7.** Histological sections of parasitic and pathogenic infections in *Cerastoderma edule* (sections stained with haematoxylin and eosin, H&E): (a) cysts of *Rickettsia* or *Chlamydia* like bacterial organisms in the epithelial tissue of the digestive gland (arrow); (b) metacercaria cluster of *Gymnophallus* spp. (arrow) in the extra-pallial space; (c) heavy infection of *Bucephalus* spp. in the gonad (arrow), with sporocyst containing developing cercaria (\*); (d) section through the foot showing metacercariae of *Himasthla* spp. (arrow). Scale bars (a & b) = 100  $\mu$ m; (c & d) = 500  $\mu$ m.

## Viruses

Viral infections in *Cerastoderma edule*, characterised by abnormal, large haemocytes with enlarged nuclei, were noted in a number of animals. The condition, referred to as haemocytic neoplastic (HN), was found in 4% ( $n=10$  of 480) of cockles, but only from Traeth Melynog (Fig. 2). It was identified in multiple tissues types amongst the samples (generally one type per individual) (Fig. 8); however, a single cockle, from Traeth Melynog (bed B, spring), contained HN in the haemolymph that was present in most tissues throughout the whole sample. Three other cockles contained the virus in more than one tissue type, suggesting a progressive infection within the host (Fig. 10 c&d). There is some minor progression in prevalence over the winter and spring sampling, with a reduction during autumn of 2015 (Fig. 2), which could suggest the virus had a detrimental effect on its host.

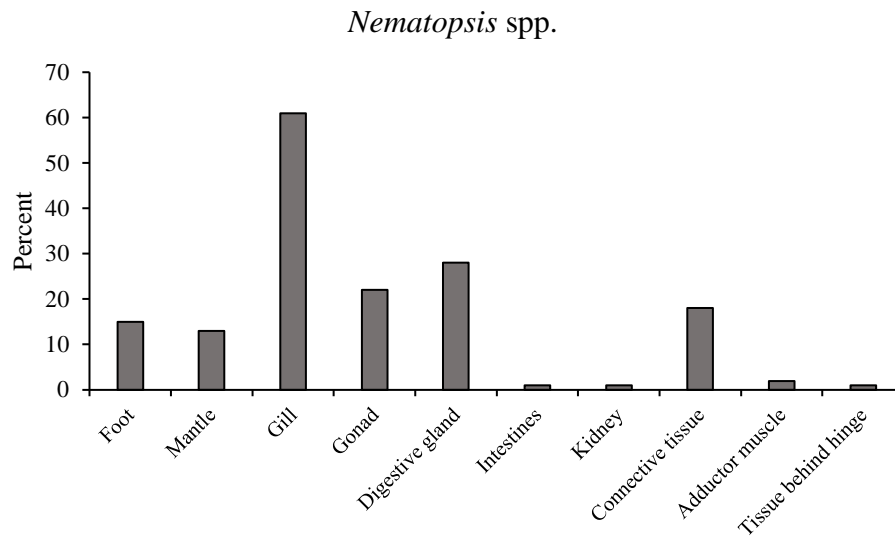


**Figure 8.** Percentage of occurrence for each tissue type identified in *Cerastoderma edule* infected with Haemocytic neoplasia ( $n=4$ ).

## Apicomplexa

*Nematopsis* spp. was present in 52% ( $n=249$  of 480) of the samples with relative even numbers between sites, 53% (TM,  $n=132$ ) and 47% (Dee,  $n=117$ ) (Fig. 2 & Fig. 12.a). The density of *Nematopsis* spp. oocytes in the host tissues was generally low, however they were observed throughout the cockles across all the main tissues (Fig. 9). Gill tissue was the most common location, occurring in 61% ( $n=152$ ) of the positive samples (Fig. 9). It also contained

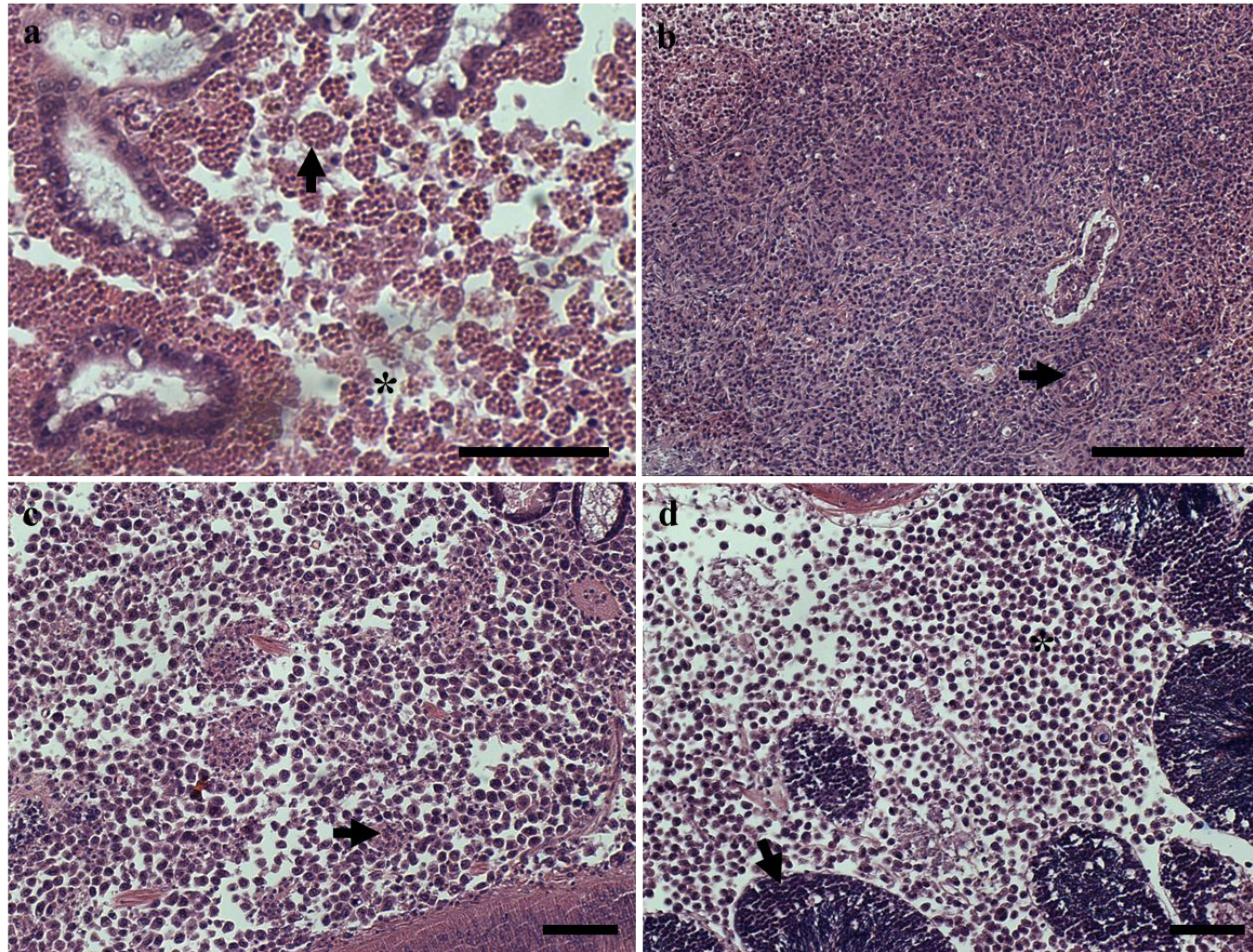
the greatest density of oocytes, where on occasions they caused lesions in the gill filaments and an inflammatory response.



**Figure 9.** Percentage of occurrence for each tissue type identified in *Cerastoderma edule* infected with *Nematopsis* spp. ( $n=249$ ).

*Pseudoklossia* spp. was present within the kidney tissue (Fig. 12.b) of four individuals, equivalent to a prevalence of <1% of the total samples ( $n= 4$  of 480). The level of infection observed is likely to disrupt kidney function. In the Dee estuary, it was present during the spring and summer months, whereas at Traeth Melynog it was only noted during the summer sampling season (single observation) (Fig. 2).

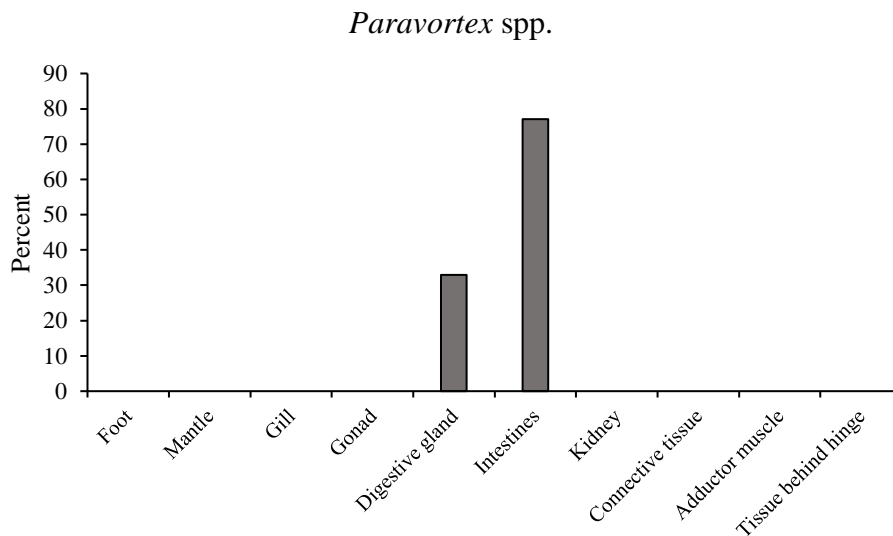




**Figure 10.** Histological sections of parasitic and pathogenic infections in *Cerastoderma edule* (sections stained with haematoxylin and eosin, H&E): (a) heavy infection of *Haplosporidia* spp. (\*) in the connective tissue of the digestive gland with plasmodia containing developing spores (arrow); (b) low power view of a large foci of haemocyte infiltration containing *Minchinia* spp. (arrows); (c) developing spores of *Minchinia* spp. surrounded by haemocytic neoplastic cells (arrow); (d) Haemocytic neoplastic cells in the connective tissue of the gonads (arrow – stage 6, male). Scale bars (a, c & d) = 100  $\mu$ m; (b) = 500  $\mu$ m.

### *Turbellaria*

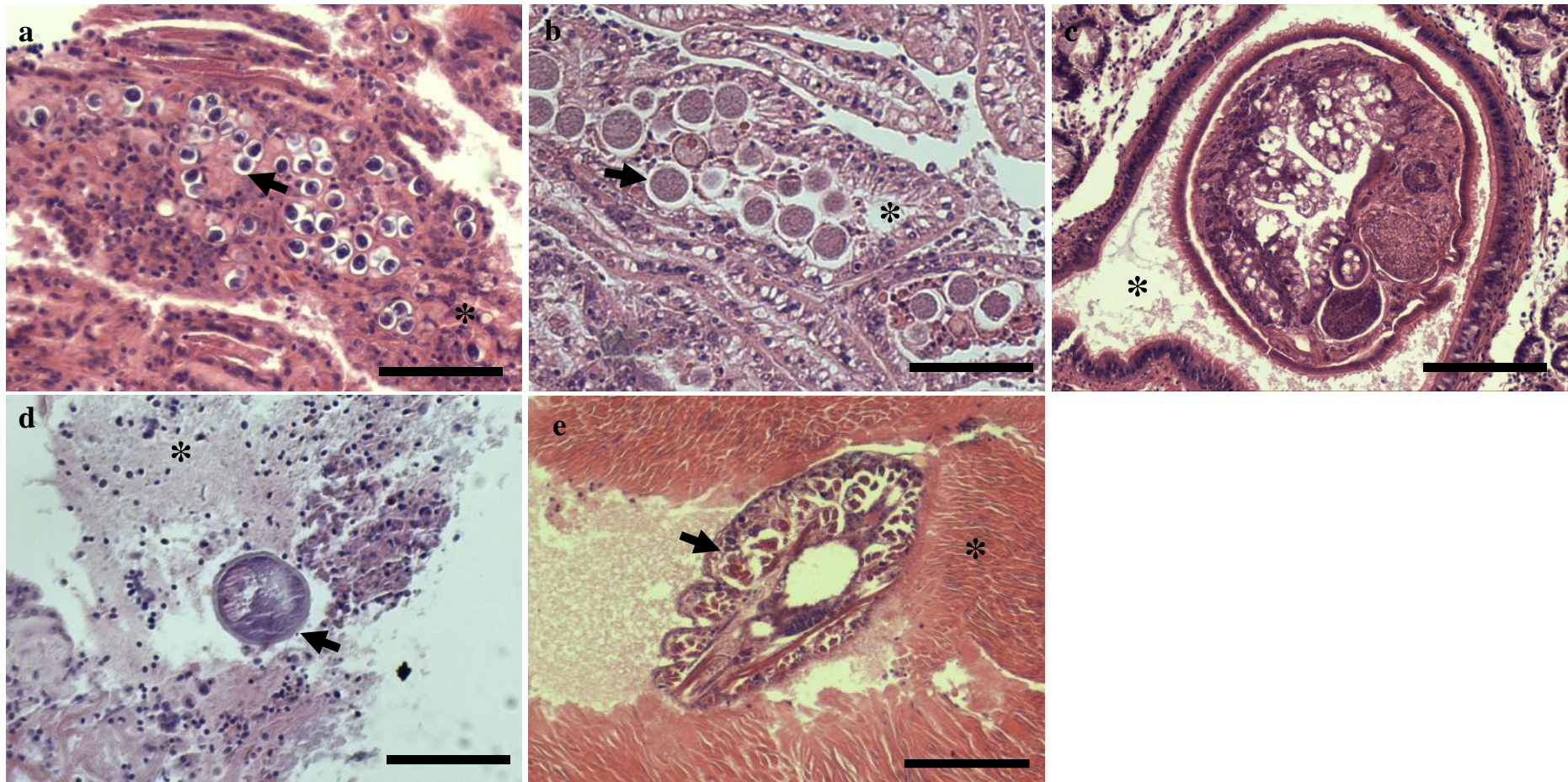
*Paravortex* spp. was made up of two species from the same genus that were distinguished by their ciliated edge and location within host. It was considered to be *Paravortex karlingi* if present within the intestinal lumen and *P. cardii*, if it was within the digestive glands (Longshaw and Malham, 2013). *Paravortex* spp. was in 21% ( $n=99$  of 480) of the total samples (Fig. 2). Prevalence of infected cockles was three times more at Traeth Melynog than the Dee estuary, accounting for 71% ( $n=70$  of 99) of the total number of individuals infected. Of the infected cockles, *P. karlingi* was present in 77% ( $n=76$ ) (Fig. 12.c) in the intestines with the remainder being *P. cardii* in the digestive gland (Fig. 11). Prevalence was also spread across all seasons for both sites (Fig. 2). There were no observations of any pathological response in consequence of *Paravortex* spp., suggesting little impact to the host cockle and supporting the view of *Paravortex* spp. as commensal microorganisms.



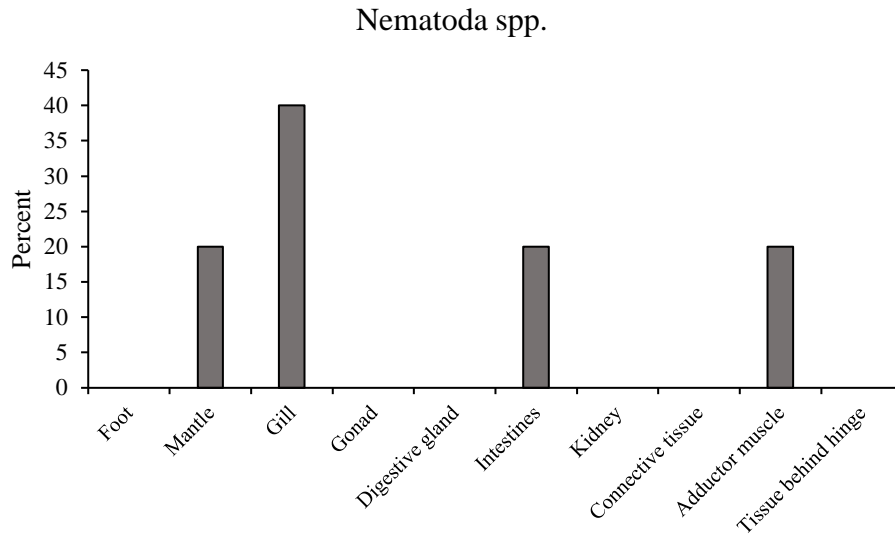
**Figure 11.** Percentage of occurrence for each tissue type identified in *Cerastoderma edule* infected with *Paravortex* spp. ( $n=99$ ).

### *Nematoda*

Unidentified parasitic nematodes were found in 1% ( $n=5$  of 480) of the total samples (Dee = 3 & TM = 2) during the spring and summer sampling periods only (Fig. 2). They occurred in the gill on two occasions, mantle, adductor muscle, and intestines (Fig. 12.d). Two of the cockles hosting this group of parasites had a shell length of less than 10mm.



**Figure 12.** Histological sections of parasitic and pathogenic infections in *Cerastoderma edule* (sections stained with haematoxylin and eosin, H&E): (a) infection of *Nematopsis* spp. (arrow) in the gill tissue, with clear pathological response to tissue structure. Normal gill structure illustrated by the (\*); (b) infection of *Pseudoklossia* spp. (arrow) in the kidney (\*); (c) cross section of a large *Paravortex karlingi* within the lumen of the intestinal tract (\*); (d) cross-section of an unidentified nematode embedded with the mantle tissue (\*); (e) cross-section of *Herrmanella* spp. in the adductor muscle (\*). Scale bars = 100  $\mu$ m.

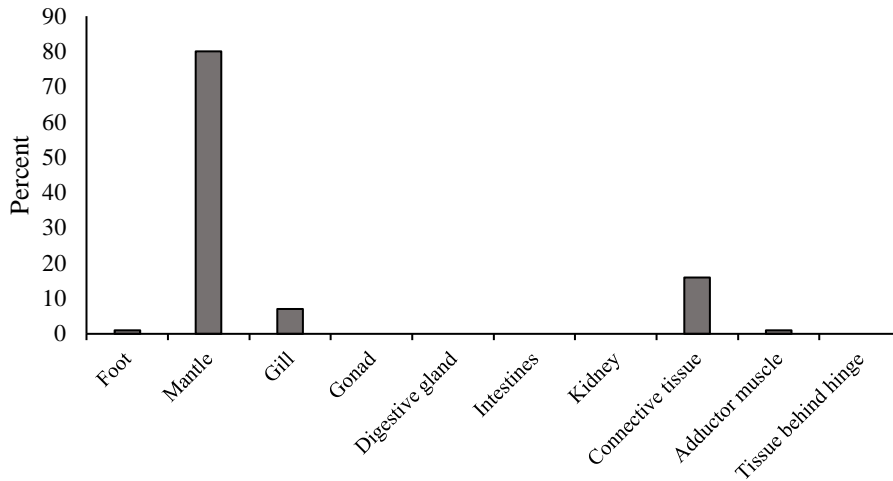


**Figure 13.** Percentage of occurrence for each tissue type identified in *Cerastoderma edule* infected with *Nematoda* spp. ( $n=5$ ).

### *Ciliophora*

The most prevalent ciliates found in *C. edule* at both sites was classified as *Trichodina* spp. The use of histology precluded the possibility of unequivocally identifying them to species level; however, the most reported species to occur in cockles is *Trichodina* cf. *cardii*. The parasite was present in 19% ( $n=97$  of 480) of all samples. From this total of 97 individuals, 54% ( $n= 51$ ) were from the Dee estuary and 46% ( $n= 45$ ) from Traeth Melynog (Fig. 2). Over half of the cockles from the summer sampling season at Traeth Melynog (bed B) were host to *Trichodina* spp. This level of prevalence represented 60% more individuals than found in any other season or location. A total of 80% ( $n=78$ ) of the infected samples hosted this ciliate either in the mantle or within its proximity (Fig. 14 & Fig. 17.a). For 16% ( $n=15$ ) of the *T. cf. cardii* infected samples it was either present in the connective tissue between the main organs or was not associated with any tissue type. *Trichodina* cf. *cardii* was present in 7% ( $n=7$ ) of the gills and, in two single individuals, was noted in the foot and in the adductor muscle (1% each) (fig. 14). No associated pathology was observed as a result of a *Trichodina* spp. infection.

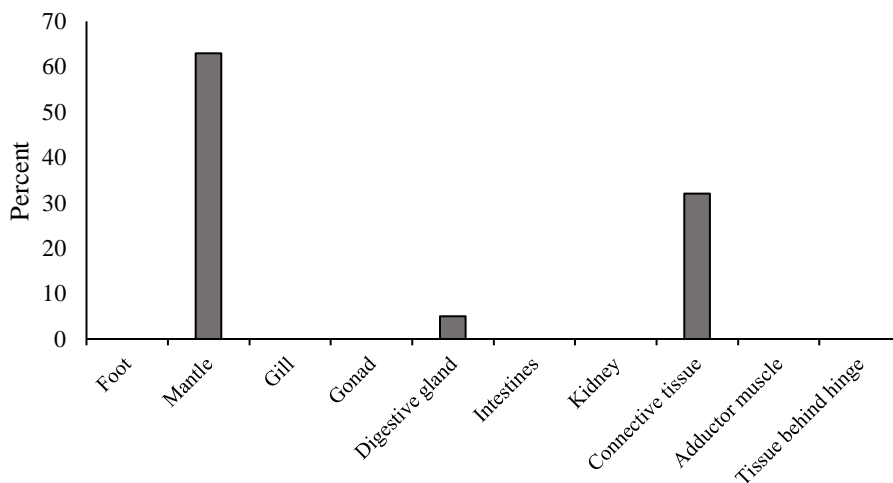
*Trichodina* spp.



**Figure 14.** Percentage of occurrence for each tissue type identified in *Cerastoderma edule* infected with *Trichodina* spp. ( $n=97$ ).

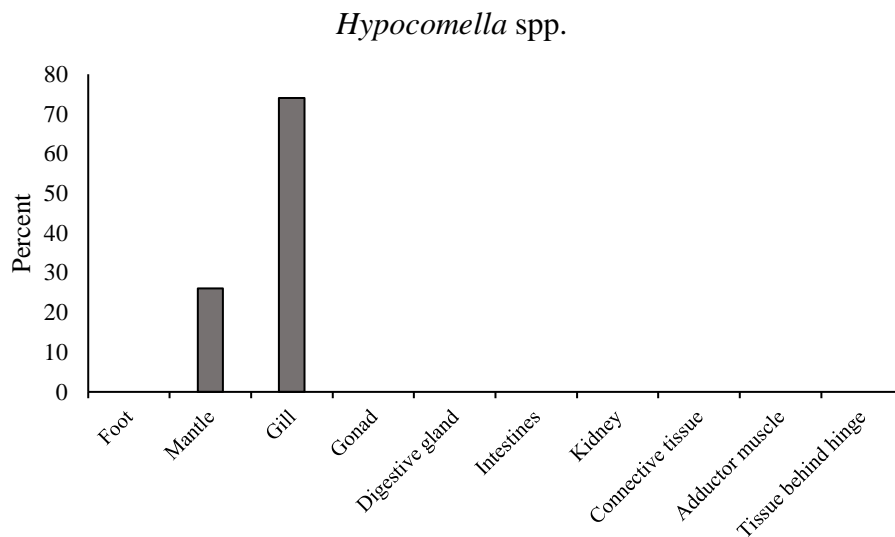
A second, unidentified peritrichous ciliate, was found in 4% ( $n=19$  of 480) of the samples. Identification to species or even genus level was not possible (Fig. 17.b). Twice as many samples infected with this group came from the Dee estuary (68%,  $n=13$  of 19) compared to Traeth Melynog. From both sites, it was present in the mantle of 63% ( $n=12$ ) of individuals, in the connective tissue or with no associated tissue in 32% ( $n=6$ ) of the sampled animals, and – in one single observation – was present in the digestive gland (Fig. 15).

Peritrichous ciliates



**Figure 15.** Percentage of occurrence for each tissue type identified in *Cerastoderma edule* affected by peritrichous ciliates ( $n=19$ ).

Another ciliate, identified as *Hypocomella raabei*, was found in 5% ( $n=23$  of 480) of the total samples. This parasite was found to be twice as prevalent at Traeth Melynog compared to the Dee Estuary. *H. raabei* was attached to the gill filaments in 74% ( $n=17$ ) (Fig. 17.c) and the mantle in 26% ( $n=6$ ) of infected cockles (Fig. 16). Some minor lesions in the gill tissue were observed that seemed to be associated with the presence of the ciliate; they were not considered to be significant. Overall, *H. raabei* was found in twice as many individuals with a shell length of over 20mm compared to than those smaller in size.

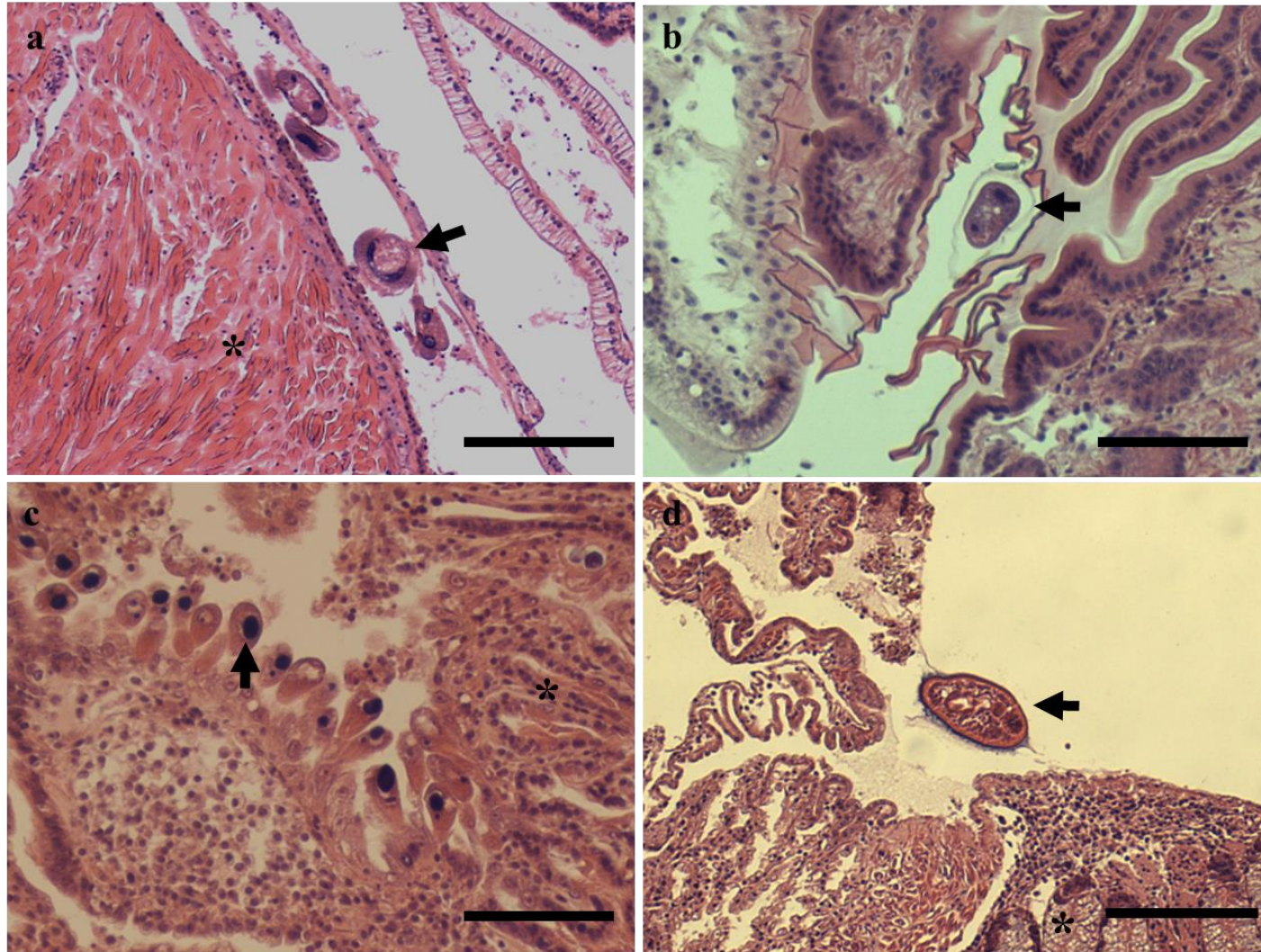


**Figure 16.** Percentage of occurrence for each tissue type identified in *Cerastoderma edule* infected with *Hypocomella* spp. ( $n=23$ ).

The last ciliate to be grouped separately was identified as belonging to the genera *Uronema* and was prevalent in 3% ( $n=15$  of 480) of the total samples. Of the cockles infected by this ciliate, 86% of these ( $n=13$ ) came from Traeth Melynog (Fig 2). This ciliate was predominantly associated with the connective tissues in the cockles or was “free-living” (Fig. 17.d). Similarities in appearance of *Uronema* spp. and *Paravortex* spp. in the tissue sections meant that classification was based on the parasite’s location within its host. Ciliated microorganisms outside of the digestive system were grouped as *Uronema* spp.

***Crustacea***

One species of parasitic Crustacea, was likely to be *Herrmanella rostrate*. It was observed at low prevalence within the samples (2%,  $n=8$  of 480) and did not display any apparent pathology on the surround tissues (Fig. 12e). Both beds within the Dee estuary and Traeth Melynog had at least one occurrence of this copepod but there was no relationship with seasons (Fig. 2). The parasite was recorded three times in the connective tissues, twice for both the mantle and adductor muscle and once in the gonad.



**Figure 17.** Histological sections of parasitic infection in *Cerastoderma edule* (sections stained with haematoxylin and eosin, H&E): (a) *Trichodina* spp. (arrow) in the connective tissue between the mantle and adductor muscle (\*); (b) stalked Peritrichous ciliates (arrow) attached to the outer epithelial tissue of the mantle; (c) *Hypocomella raabi* (arrow) attached to the gill tissue, with normal gill tissue structure (\*); (d) *Uronema* spp. (arrow) with clear ciliated.. Scale bars (a - c) = 100  $\mu$ m, (d) = 250  $\mu$ m.



### 4.3.2 Multivariate analysis

The ordination observed through the multidimensional scale analysis revealed clustering of the sampling points according to the factor level site, implying that there are differences in the community structure of parasite and pathogenic groups between the Dee estuary and Traeth Melynog, across the whole of the sampling period (Fig. 18). The R statistics from ANOSIM of 0.494 confirms this observation, demonstrating that there is significant dissimilarity ( $p=0.001$ ) (Table 7). For the pairwise comparisons of seasons (not distinguishing between sites), the ANOSIM returned a low R statistic of 0.044 and were not significant ( $p=0.348$ ). All seasons, irrespective of site, were similar to one another in terms of their overall effect on the parasite and pathogenic community structure. Within site analysis does suggest there is some small dissimilarity between seasons within each of the sites as the R values are greater than 0, however these differences were not significant (Dee:  $p=0.269$ ; TM:  $p=0.208$ ). There was also no observed difference between beds A and B within each site with the R values for these close to 0 (Dee:  $p=0.625$ ; TM:  $p=0.394$ ) (Table 7). This non-significant result between each bed within sites is also demonstrated by the overlap of the elliptical clusters in the multidimensional scale plot, which explain 95% variability of the data points (Fig. 18).

**Table 7.** Summary of ANOSIM results

Test	R statistic	P value
Site	0.494	<b>0.001</b>
Season	0.044	0.348
<i>Within group</i>		
Dee estuary		
Season	0.167	0.269
Bed	-0.063	0.625
Traeth Melynog		
Season	0.271	0.208
Bed	0.031	0.394

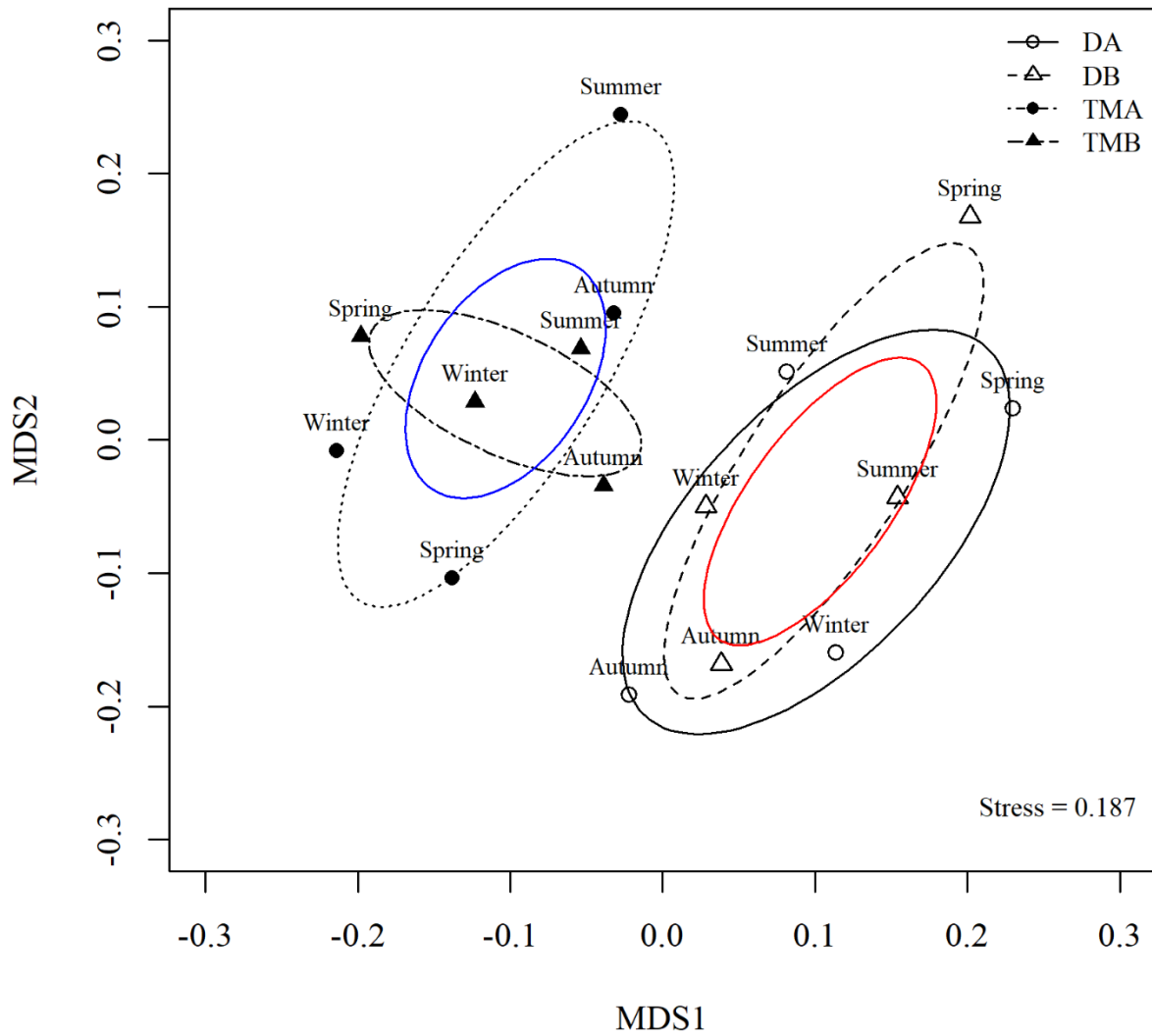
Results from the SIMPER analysis for between sites returned an average dissimilarity contribution of 25.38% for the parasite and pathogenic groups, which was considered to be relatively low. The significant dissimilarity seen from the ANOSIM analysis is therefore likely to be strongly influenced by six groups that account for over 51% of cumulative contribution (Table 8). These groups either had comparatively higher global prevalence at Traeth Melynog

Chapter 4

compared with the Dee estuary, or were only observed at Traeth Melynog (Fig. 2). They include (in order of decreasing importance) *Paravortex* spp., *Himasthla* spp., *Uronema* spp., Haemocytic neoplasia, Epitheliocystis and *Bucephalus* spp. (Table 8), with all six groups displaying a high ratio, an indicating that these are good for discriminating between sites. The top two groups, *Paravortex* spp. and *Himasthla* spp. were consistently found at both sites across all seasons but found in a high percentage of cockles at Traeth Melynog (Fig. 2). They contributed almost 20% of the cumulative sum to the significant dissimilarity found between sites and the ratio for both groups was high, an indication that they are the dominant discriminating groups between the two sites.

**Table 8.** Summary of SIMPER results of the dissimilarity of the parasite and pathogen groups between the Dee estuary and Traeth Melynog. For full group names, see Table 6.

Group Names	Average contribution	SD	Ratio	Cumulative contribution
Para	0.026022	0.014409	1.806	0.1025
Him	0.024305	0.01192	2.039	0.1983
Uro	0.020439	0.016817	1.2153	0.2788
HN	0.02022	0.012658	1.5975	0.3585
Epi	0.019836	0.013962	1.4207	0.4366
Buc	0.019665	0.013495	1.4572	0.5141
Peri	0.019357	0.017225	1.1237	0.5904
Tri	0.019102	0.013867	1.3776	0.6657
Nem	0.015364	0.011094	1.3849	0.7262
Hypo	0.01356	0.009685	1.4002	0.7796
Her	0.012303	0.012136	1.0138	0.8281
Gym	0.009898	0.007379	1.3413	0.8671
UnNem	0.008859	0.013275	0.6674	0.902
Pseu	0.007951	0.011815	0.6729	0.9333
Hap	0.006527	0.00977	0.6681	0.959
Perk	0.005269	0.00921	0.5721	0.9798
Min	0.005128	0.008967	0.5719	1



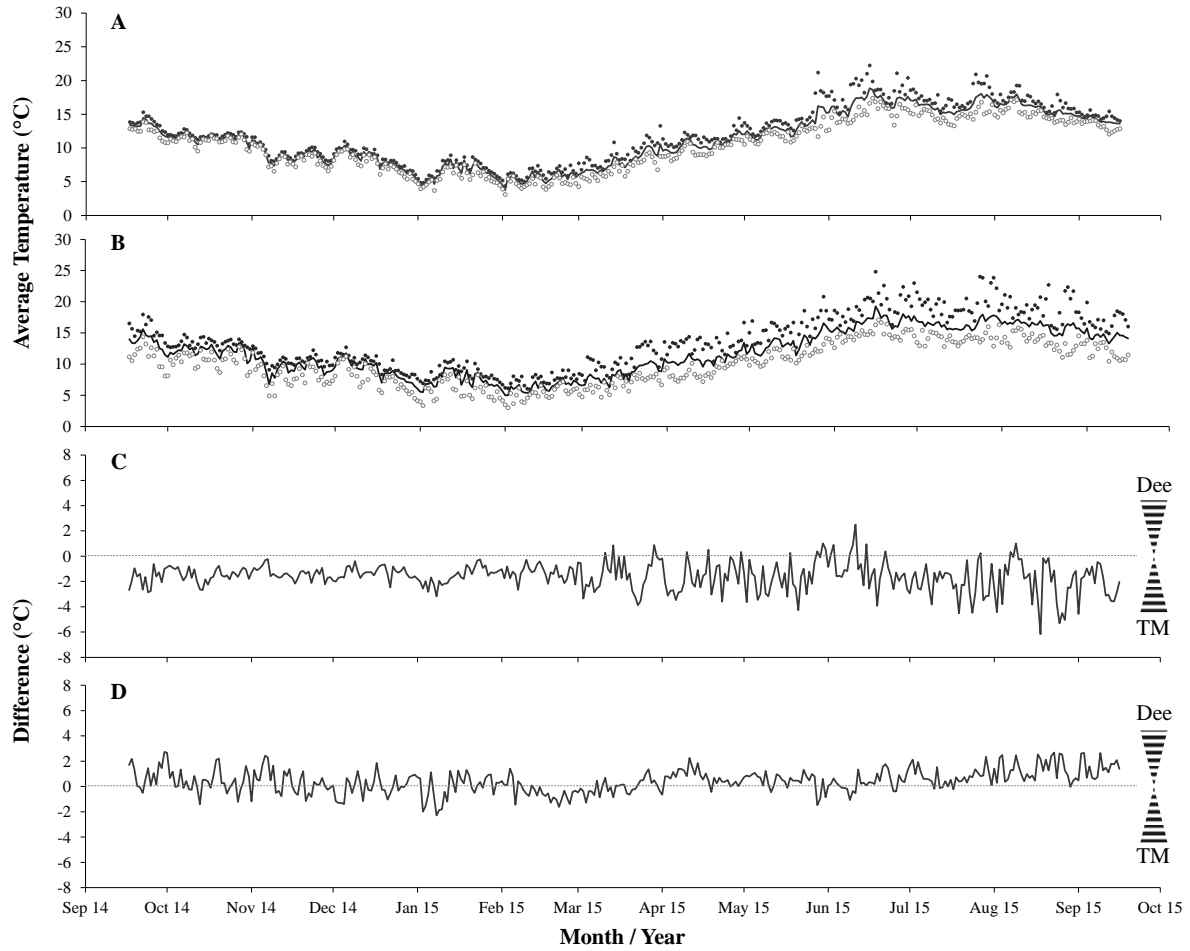
**Figure 18.** Multidimensional scale plot, derived using square-root transformed Bray-Curtis similarity matrix, indicating the similarity between the parasite and pathogen communities at the different sampling locations and seasons. Elliptical clusters explaining 95% of the variability between sites, Dee estuary (blue) and Traeth Melynog (red), and for beds, A & B within each site (black – varied line pattern). Stress = 0.187

**Temperature data**

During the sampling period, the sediment temperature at the Dee estuary ranged from 3.14°C in February 2015 to 22.27°C in June 2015 with an overall mean of 11.24°C (Fig. 19). For Traeth Melynog the mean temperature recorded was 11.74°C: it ranged from 3.03°C February 2015 to 24.8°C in June 2015. Results from the multiple linear regression analysis showed that there were significant differences in the temperature of the sediment between the independent variables months ( $p < 0.001$ ) and site ( $p < 0.001$ ) (Table 9). The interaction between month and site did not show any significance implying that the differences between sites is not dependent upon month.

**Table 9.** ANOVA output of the significant interactions that can explain the temperature of the sediment in the multiple linear regression model. Significant values are in bold.

<b>Variable</b>	<b>df</b>	<b>Sum of Squares</b>	<b>Mean Squares</b>	<b>F value</b>	<b>P value</b>
Month	11	9420.8	856.43	703.4351	<b>&lt;0.001</b>
Site	1	46.1	46.14	37.8980	<b>&lt;0.001</b>
Month : Site	11	18.7	1.70	1.3976	0.1689
Residuals	706	859.6	1.22		



**Figure 19.** Average daily temperature of the sediment at 5cm depth during the sampling period for both the Dee Estuary (A) and Traeth Melynog (B) (solid line), with the maximum (●) and minimum (○) values shown for each day. Differences in temperature illustrated in graphs C (maximum temperature difference) & D (minimum temperature difference). Positive values indicate that the Dee Estuary had a higher temperature than Traeth Melynog and negative values indicates Traeth Melynog had a higher temperature than the Dee Estuary.

#### 4.4. Discussion

##### 4.4.1 Spatial and temporal variation in the parasite and pathogen communities

The findings from this study have shown that the different parasite and pathogen groups and their prevalence within a population can be controlled by the location of the cockle bed. Seventeen different parasite and pathogen groups were identified in *Cerastoderma edule* from this study from, 15 of these were found to be present in the Dee estuary and 16 from Traeth Melynog (Fig. 2). The cockle beds from the Dee estuary and Traeth Melynog were different in part as a result of two groups being absent from the Dee estuary, Haemocytic neoplasia or *Perkinsus* spp. and the single group, *Minchinia* spp., absent from Traeth Melynog. However, these groups had low prevalence in comparison to all other groups identified (Table 6; Fig. 2) which were shown to have a higher contribution to the site dissimilarities, for example *Paravortex* spp. and *Himasthla* spp. (Table 8). Similar studies have found variation in the composition of parasitic groups between different sites sampled (Carballal et al., 2001; Elliott et al., 2012). Previous research carried out in the Dee estuary in 2009 identified 15 groups, with *Nematopsis* spp., *Trichodina* spp., and *Gymnophallus* spp., being the most prevalent over the 17-week sampling period (Elliott et al., 2009). This study also found *Nematopsis* spp. to have a high prevalence in the Dee estuary, but *Himasthla* spp., and *Gymnophallus* spp., were more dominant than *Trichodina* spp. Elliott et al., (2012) also studied the Burry Inlet at the same time and separated their findings into 19 separate groups. Research conducted in North West Spain also found a variation in the prevalence of different parasitic groups across a spatial scale. Carballal et al. (2001) found *Nematopsis* spp. and large cysts enclosing bacteria like microorganisms, to be the most prevalent groups found across 34 sampling sites. *Paravortex* spp. were also abundant, which was similar to our findings, as well as similarities for *Pseudoklossia* spp. and *Trichodina* spp. (Carballal et al., 2001). Differences between this study and studies by Elliott et al. (2012) and Carballal et al. (2001) is that sampling was conducted over a longer period of time. Carballal et al. (2001) sampled during the spring, whilst Elliott et al., (2012), conducted sampling between the spring and summer months only. Although no significant effect of season was found on the community structure of parasites and pathogens, there were differences in some groups, either appearing in a higher percentage of the population or being absent between the autumn and winter sampling (Fig. 2). This study did not identify any new parasites or pathogens that have not been identified previously in Wales. However, there was only a low number of cockles used in the study and the frequency of sampling at 3

to 4 month intervals over the year, mean that certain groups could easily have been missed. Future research looking at parasite, pathogen and disease communities within cockle fisheries should consider sampling over a longer period of time, and at a greater resolution than this study. This would provide greater accuracy to the changes in prevalence of the different species and could potentially give more accurate assessments of the community structure. It may also identify pathogens that may be present in low numbers of the populations which have the potential to cause significant harm at a population level.

#### **4.4.2 Parasites and pathogens of most importance to the health of the fisheries**

Out of the 17 parasite and pathogen groups, six are known as having the potential to cause significant physical harm to an individual cockle and therefore potentially have a negative population level effect. This means that their presence is cause for concern (Longshaw and Malham, 2013; Woolmer et al., 2013). These groups are the digeneans *Bucephalus* spp., *Gymnophallus* spp. and *Himasthla* spp., the haplosporidans *Haplosporidium* spp. and *Minchinia* spp. and virus Haemocytic neoplasia.

##### ***Digenean parasites***

*Cerastoderma edule* are used by *Bucephalus* spp. as their first intermediate host (Russell-Pinto et al., 2006; de Montaudouin et al., 2009). This common parasite follows a typical trematode lifecycle of three-host species with transmission between hosts through the environment (Poulin and Cribb, 2002). During its transition from miracidium (the first larval stage) to its adult form (Magalhães et al., 2015), the parasite goes through the sporocyst and cercarial stages of development when infecting *C. edule* (Russell-Pinto et al., 2006; de Montaudouin et al., 2009; Pina et al., 2009; Morgan et al., 2012), both stages were observed in this study.

The sporocyst infection which was observed in the gonads of the cockles from both sites (Fig. 7.c) was likely to belong to the species *B. minimus* (Montaudouin et al., 2009; Pina et al., 2009; Longshaw and Malham, 2013). It has been documented to castrate the cockle host by invading the gonads and interfering with normal development of the gametes (Carballal et al., 2001; Pina et al., 2009). There was clear evidence to suggest that the *Bucephalus* spp. infection in our samples reduced the reproductive output of the individual cockles, but the level of severity was not quantified. As sporocyst's develop they destroy the surrounding tissue

within the gonad and reduce the space available for maturing gametes. Detrimental effects to the other tissues, in particular the digestive glands, and the weakening of the cockle by absorbing its stores of lipids and carbohydrates are other consequences of infection (Longshaw and Malham, 2013). Traeth Melynog showed the highest infection prevalence in cockles that were over 20 mm shell length. This size class contributes a higher proportion of the total larvae generated over the spawning season compared to other size classes (Helm, 2004): a mature female can release in excess of 1 million eggs over a spawning season (Tyler-Walters, 2007). Castration to this size class could therefore have a disproportional effect on the total reproductive output of a population if its prevalence was high.

Developing through sexual amplification within the germinal cells of the sporocyst's are cercaria (Fig. 7c), the second larvae form of *Bucephalus* spp. (Poulin and Cribb, 2002). Cercaria intended for the second intermediate host emerge from the sporocyst and temporarily live throughout the host's body (observed in this study) eventually working their way out of the host as free swimming cercariae. In cockles where cercariae were found the only pathological responses were small liaisons to tissues surround the parasite; but these were not considered to be at a level that would cause harm to the cockle. Pina et al., (2009) studied the life cycle of *B. minimus* and, by using DNA sequencing, confirmed that adult stages of this parasite extracted from *Dicentrarchus labrax* and cercariae taken from *C. edule* belonged to the same species. The parasites second intermediate hosts are benthic fish, and transmission of cercariae between hosts is affected through the environment (Poulin and Cribb, 2002). There is only a short window of up to 48 hours for transmission to be successful (Anderson & Whitfield, 1975; Pechenik and Fried, 1995), so it is beneficial for the parasite to utilise fish found within close proximity. The second intermediate host of *B. minimus* are the gobids *Pomatoschistus microps* and *P. minimus* (Faliex and Morand, 1994) and the flat fish *Pleuronectes platessa* (Matthews, 1973) (Pina et al. 2009; Freitas et al., 2014) where transition into metacercariae occurs. The final intermediate host of *B. minimus* is *D. labrax* where the metacercariae metamorphose into their adult form and begin sexual reproduction. The life cycle is complete when the gametes of *B. minimus* are released through the faecal material of *D. labrax* and the eggs hatch into miracidium. which complete the lifecycle by infecting cockles (Schmidt and Roberts, 2000; Longshaw and Malham, 2013). Because *C. edule* plays an important role in this parasite's lifecycle, its prevalence can be considered an indicator of the ecosystem health (Poulin, 1999). If *Bucephalus* spp. is present within any cockle population, then there must also be the necessary species of fish sharing the same habitat for the parasite



to complete its entire life cycle. *Bucephalus* spp. are common parasites of *C. edule* and are found throughout the UK cockle populations (Elliott et al., 2012; Woolmer et al 2013). If cockle numbers are low, then there is less chance of miracidium finding a suitable host and as a result could lead to less cockles being infected. Yet high infection rates could indicate there also being a higher number of second intermediate and final hosts within the system, giving the parasites more chance of reproducing. This means there has to be a sufficient amount of prey items, e.g. cockles, available to support greater numbers of species higher up the food chain. The 4% prevalence found in this study is less than the mean prevalence of 7.7% found in a review of the literature regarding *B. minimus* infection in different sites across Europe (Magalhães et al., 2015). Prevalence of over 40% have been demonstrated in Arcachon bay, France and 26.4% in Plymouth, England (Hutton, 1952; Deltreil and His, 1970).

Caution should be exercised in comparing prevalence between different studies across Europe as there are significant time gaps between them and prevalence can change dramatically within sites on a yearly basis (Magalhães et al., 2015). These authors also conducted their own 16-year study in Arcachon Bay which sampled cockle's for *B. minimus* infection on a monthly basis. An overall mean prevalence of 6.2% (min 2.2%, max 15.9%) was observed but there was no display of seasonality during this time period. Although this study also did not present an *overall* seasonality prevalence across the year, at Traeth Melynog the autumn and summer months were slightly more favourable to infection (Fig. 2). This evenness across seasons and our low prevalence could be attributed to: 1) the histology screening methods may miss parasites which are present but have not been sectioned onto the slide; or 2) the parasites lifecycle also does not conform to seasonality and infects the non-migratory fish species that are present throughout the year (Magalhães et al., 2015). It was observed that heavy sporocyst infection dominated cockles that were in the later stages of gametogenic cycle. It is therefore likely that the miracidium infect cockles around late winter to early spring. During the summer sampling at Traeth Melynog, individuals were recorded to contain *Bucephalus* spp. in multiple tissues, including the gonad, digestive gland, gill and mantle, leading to suggest that cercariae may be working their way out of the host around this time of year.

It has been reported that if cockles are weakened as a result of infection by *Bucephalus* spp. then their burrowing ability is affected (Desclaux et al., 2002; Longshaw and Malham, 2013). Mass surfacing of cockles is associated with atypical mortality events such as the result of parasite infection (Elliott et al., 2012; Woolmer et al., 2013). Whether surfacing or inability to burrow effectively is caused directly from the parasite to promote host transmission, or

indirectly because of the energy loss from a reduction in the respiration rate and oxygen uptake (Javanshir, 2001), remains to be determined. Either way, not being able to burrow effectively leads to greater exposure to the hydrodynamics of the intertidal environment (Sassa et al., 2011), increased predation pressure (Norris et al. 1998; Thomas and Poulin, 1999; Malham et al. 2012) and possible desiccation.

Decreased burrowing ability has also been shown to be closely related to infection from another trematode belonging to the *Himasthla* spp. (Thieltges, 2006), and infection rates of up to 100% have been observed in surfacing cockles from two locations, Arcachon Bay, France (Declaux et al., 2002) and Sylt Island, Germany (Thieltges and Reise, 2006). Across the groups of parasites and pathogens observed in this study, it was the *Himasthla* spp. which displayed the greatest prevalence for all beds and seasons (Fig. 2). Prevalence of 59% is low in comparison to other studies. To remove bias associated with parasite induced behaviour, however, only burrowed cockles were sampled. *Himasthla* spp. follow a different host cycle to other digenea, e.g. *Bucephalus* spp. Dependant on the species, the first intermediate stage takes place in small gastropods e.g. *Hydrobia ulvae* and *Littorina littorea* (de Montaudouin et al., 1998), the second intermediate stage taking place in bivalves, e.g. *C. edule* and *Mytilus edulis* (Bowers, 2009), and the final definitive hosts are the seabirds *Larus* spp., *Haematopus ostralegus* and *Somateria mollissima* (Longshaw and Malham, 2013). *Himasthla* spp. identified in *C. edule* were in the metacercariae stage, with cysts found throughout the foot and mantle (Fig. 7d). These cysts are not considered to have a significant impact on the population dynamics of *C. edule* (Longshaw and Malham, 2013; Woolmer et al., 2013) and only abundant infestation can have some impact to an individual's growth and condition index (de Montaudouin et al., 2012). In general, the reproductive stages (e.g. sporocysts in the first intermediate host) of digeneans are often considered pathogenic to their host, whereas the dormant stages (e.g. the metacercariae in the second intermediate host) are considered harmless and could explain why infection with *Himasthla* spp. is of less concern (Wegeberg and Jensen 2003).

The metacercariae of the digeneans belonging to the group *Gymnophallus* spp. were found in relatively high prevalence at both sites across all sampling seasons (Fig. 7b). They are a common group of parasites infecting *C. edule* along the North Eastern Atlantic coastline (Pina et al., 2009). Five species belong in the family Gymnophallidae are known to infect cockles as either their first or second intermediate host. These include *G. choledochus* (1<sup>st</sup>), *G. gibberosus* (2<sup>nd</sup>), *G. fossarum* (2<sup>nd</sup>), *G. minutus* (2<sup>nd</sup>) and *G. strigatus* (2<sup>nd</sup>) (de Montaudouin et al., 2009)

(Chapter 1, Fig. 2). Based on the morphology characteristics of this parasite, their location within the host (behind the shell hinge in the extra-pallial space - Bowers et al., 1967, Bowers et al., 1996) and the estuarine environment, we consider it to be of species *G. minutus*. Cockles infected with *G. minutus* are stimulated to produce excessive ligament protein which accumulates around the parasites in the extra-pallial space. This is because to metacercariae feed on ligament protein intended for the ligament itself and therefore increasing the production (Bower et al., 1996). This mass of ligament protein engulfing the metacercariae was visible to the naked eye when dissecting infected samples for analyses and was pale in colour (pers. obs). The excess ligament produced can interfere with the fit between the shell by the tooth and cavity located by the shell hinge, causing the ligament to contract and a loss of contact of the anterior shell edges (Bower et al., 1996). Cockles from the Burry Inlet, south Wales that contain a higher than average infestation have been shown to be found near to or gaping at the surface during low tidal periods with the suggestion that the accumulation of these metacercariae has an adverse effect on the cockles burrowing efficiently (Bower et al., 1996). However, metacercariae of *G. minutus* can be found in a high prevalence of cockles along the southern coast of Ireland, but this has not been reported as negatively impacting their burrowing ability, inducing gaping or causing obvious mortalities (Fermer et al., 2010). Fermer et al., (2010) observed a mean prevalence of 94% across their sampling sites in cockles (>10mm shell length) collected from within the sediment, which is much greater than our own observations of 34%. They also found the mean intensity of individual *G. minutus* within a host to be 387 ( $\pm 370$ ), with a maximum number of 5521 within an individual cockle. It is therefore plausible that behaviour of the cockles is not just limited to infection of a single species of parasite but may be a response to multiple groups of parasite or pathogens present in the individual. It is suggested that the intensity – i.e. the number of metacercariae found within a single host – correlates with mortality events. For gymnophallids, this can be when the population reaches a mean of 500 per cockle<sup>-1</sup> and is not dependent upon season (Gam et al., 2009). For the *Himasthla* spp. it is much lower at between 10 ~ 50 individual metacercariae in cockles from the same location (Desclaux et al., 2002). These mortality thresholds are also influenced by temperature. *C. edule* found in the southern end of their distributional range display a mean of 15 metacercariae per cockle<sup>-1</sup>, indicating that higher temperatures increase the vulnerability of infection (Jensen et al., 1996; Gam et al., 2008).

*Gymnophallus minutus* (and other members of the family Gymnophallidae) follow a typical trematode three host lifecycle, by first infecting *Scrobicularia plana* and then on

through to the final host *Haematopus ostralegus* (Chapter 1, Fig. 2; Bowers et al., 1996; Ferma et al., 2010; Longshaw and Malham, 2013). Both these host species were present at each site (pers.obs). The hosts differ slightly from those used by other digeneans such as *Bucephallus* spp. where final hosts are fish, and *Himasthla* spp. where first intermediate hosts are gastropod molluscs (Pina et al., 2009). Because of their complex lifecycle and the need to have several host species representing different trophic levels, i.e. invertebrates and vertebrates, trematode parasites have been proposed as being a good indicator of biodiversity within a localised area (Hechinger et al., 2007). A free-living stage which is sensitive to its environment, can also be used as a proxy to monitor changes to the environment and for assessing the stability of a cockle population (Hudson et al., 2006; de Montaudouin et al., 2012; Magalhães et al., 2015). These parasites also reflect the ecology of their host and therefore the population structure of the parasitic community will vary depending on the mode of transport for the specific species. For example, *Gymnophallus choledochus* show a high degree of genetic variation spread over a wide distance. Yet, *Bucephalus minutus* have been found to display a strong population structure indicating the occurrence of sub-populations of the parasite and less connectivity between sites (Feis et al 2015). This is explained by the limited distributional range of their fish hosts in contrast to that of migratory birds which cover large distances and therefore spread the parasite genes more widely.

### *Haplosporidian parasites*

Haplosporidian parasites are found in wide range of marine invertebrates and those that infect bivalve molluscs are known to cause significant harm to the hosts. There are four genera in this phylum. These are *Haplosporidium*, *Minchinia* and *Bonamia* (Ford and Tripp, 1996; Azevedo et al., 2003; Carballal et al., 2001; Carballal et al., 2003; Ford et al., 2009; Longshaw and Malham, 2013; Hartikainen et al., 2014; Arzul and Carnegie, 2015). The fourth genera, *Urosporidium*, are hyper-parasitic and infect the tubellarian, *Paravortex cardi*, associated with *C. edule* and are not considered to be directly harmful to them (Carballal et al., 2001).

An outbreak of a haplosporidian-like parasite was responsible for the death of *Pinna nobilis* along the southern Spanish coast and islands in the Mediterranean Sea. Mortality rates of up to 100% occurred at some locations (Vázquez-Luis et al., 2017). Further research has suggested the species *Haplosporidium pinnae* was responsible for the observed mortalities in *Pinna nobilis* as it was also identified in dead or moribund cockles, demonstrating that infection

of these types of parasites can be fatal (Catanese et al., 2018). Incidentally, this parasite was not observed in healthy individuals where there is no abnormal mortality (Catanese et al., 2018). Along the mid-Atlantic coastline of the United States, *C. virginica* has suffered significant mortality events due to infection of *H. nelsoni* over the past four decades (Andrews, 1984; Robledo et al., 2018). Originally, this pathogen was introduced with imported spat to the United States of America from Asia where it infects *C. gigas* and has been attributed to causing over 90% mortality rates in *C. virginica* (Burreson et al., 2000). By way of comparison, in the north eastern Atlantic, *H. nelsoni* has recently been found in low prevalence in two oyster species, *Crassostrea gigas* and *Ostrea edulis*, expanding the known geographic and host species distribution of this particular species (Lynch et al., 2013). Lynch et al., (2013) also reported a single *O. edulis* to be infected with *H. armoricanum*. Neither *H. nelsoni*, nor *H. armoricanum* were believed to have any significant impact to the oysters as the prevalence and intensity of infection was low. Low prevalence is common for *Haplosporidium* parasites within bivalve molluscs and may not be associated with any negative impact to the host (Arzul and Carnegie, 2015). *H. armoricanum* has been reported to occur at a mean prevalence of 4.1% in *O. edulis* from Galicia, Spain (da Silva et al., 2005) and the prevalence of *H. nelsoni* – which is common in *C. gigas* from France – is usually below 4% (Garcia et al., 2006). For both parasite species, detection has not been associated with any significant mortalities to the oysters (Arzul and Carnegie, 2015).

The *Haplosporidium* spp. found in this study can be identified as the species *H. edule* based on the level of observed pathology associated with infection (Fig. 10.a); and it was deemed to be detrimental to the host. First described in studies of cockles from Galicia, north-west Spain by Azevedo et al., (2003), the plasmodia, sporont and sporocyst stages of this parasite are typically extracellular, invading connective tissues or epithelia. It can occur in multiple tissues throughout the cockle but is more predominant in the digestive gland and its surrounding tissue (Longshaw and Malham, 2013). Prior to work of Azevedo et al., (2003), a *Haplosporidium* spp. was observed in research undertaken by Carballal et al., (2001) with sampled cockles from North West Spain. It is likely this species also *H. edule* but was not formally identified in the study (Carballal et al., 2001). More recently, *H. edule* has been identified in the digestive gland of cockles collected in the Netherlands (Engelsma et al., 2011).

Little is known about the aetiology specifically associated with *H. edule* and therefore other species of *Haplosporidium* may help provide some insight to the dynamics of infection

in relation to *C. edule*. The parasite will likely infect cockles via the inhalation of spores which are present in the water column (Ford and Barber, 1995). Spores are shed from living hosts (possibly other cockles) once sporulation is complete which can cause premature mortality to the host by weakening the individual (Robledo et al., 2018). Whether spores are released through faecal material, similar to *B. minutus*, or from decaying tissue of a recently deceased host, as seen in *Perkinsus* spp. (Robledo et al., 2018), remains to be determined. When released, spores are distributed by the tide and currents and their survival and geographic distribution is influenced by environmental conditions (Hartikainen et al., 2014; Arzul and Carnegie, 2015). Low temperatures of 4°C and salinities above 35‰ increase the opportunity for survival of the haplosporidian *Bonamia ostreae*, which is known to infect *Ostrea edulis*. Chesapeake Bay, eastern United States, has seen the infection prevalence of *H. nelsoni* intensify in areas which have become more saline due to drought (Burreson and Ford, 2004). On the other hand, for both *H. nelsoni* and *B. ostreae*, there is evidence that the destruction of the parasites is more likely to occur when temperatures are high (>15°C) and salinities are low (< 20‰) (Arzul et al., 2009; Flannery et al. 2014; Arzul and Carnegie, 2015). The infections in this study were observed in the winter and spring sampling seasons, a time when temperatures were generally lower compared to the autumn and summer months (Fig. 19). Sporulation may be seasonal as seen for *H. nelsoni*, with it being shown to take place in *C. virginica* two times per year, coinciding with the months June/July and late summer to early autumn (Barber et al., 1991). All observations of *Haplosporidium* spp. in this study showed evidence of sporulation (Fig. 10a) whereas the intensity of infection was greatest in the cockles sampled in the spring. To test seasonality of sporulation for *H. edule*, monthly sampling would be necessary over a period greater than one year to build an understanding of when infection and sporulation is likely to occur and is visible via histology.

*Haplosporidium* spp. life cycle is complex and within the genus, different species have wide range of hosts including but not limited to, polychaetes, crustaceans and echinoderms. (Burreson and Ford, 2004). It is unknown if an intermediate host is required for this group of parasites to complete their lifecycle or if there is direct transmission of spores between cockles which would indicate a direct life cycle with the host (Arzul and Carnegie, 2015; Robledo et al., 2018). Multiple hosts have been reported for *H. nelsoni* through DNA analysis, and it has been identified in both *Crassostrea virginica* and in tunicates belonging to the genus *Stylea* (Robledo et al., 2018). It is therefore possible that *H. edule* shares the intermediate host hypothesis, but this too requires further investigation.

The observation of foci of heavy haemocyte infiltration in the samples (Fig. 10 b & c) from the Dee estuary in the winter and spring sampling periods points to infection of a *Minchinia* like parasite. Similar observations have been reported from the cockles in the Netherlands (Engelsma et al., 2011), Spain (Carballal et al., 2001; Villalba et al., 2001; Carballal et al., 2003; Ramilo et al., 2018) and the UK (Elliot et al., 2012), which have all been linked to the *Minchinia* spp. group. In total there are 5 species belonging to the genera *Minchinia* and two have been shown to infect cockles. These are *M. mercenariae* (Ramilo et al., 2017) and *M. tapetis* (Engelsma et al., 2011), however neither species has yet to be confirmed as infecting cockles in the UK (Ramilo et al., 2018). An investigation into the cockle mortalities observed in the Burry inlet, South Wales, UK showed signs of unidentified Haplosporidian infections which were attributed to be *Minchinia* sp. and *Haplosporidium* sp. (Elliot et al., 2012). There is debate about whether past observations of large foci of heavy haemocyte infiltration a result of infection by *Minchinia* spp. is This is because re-examination of historical slides, and the repeat of molecular analysis on samples taken from Galicia, Spain displaying this morphology, failed to detect any *Haplosporidian* signal (Ramilo et al., 2018).

Although no positive identification from cockles in the UK exists, the first molecular evidence of *Minchinia* has been found in water column samples taken from the Fleet Estuary along the south coast of the UK (Hartikainen et al., 2014) and shows that this parasite does occur in UK waters. Three *Minchinia* species were found, one closely resembling *M. mercenariae*, one similar to *M. mercenariae* but deemed to be a new species, and one that was identical to *M. tapetis*. The results strongly indicate a planktonic phase of the parasite's life-cycle with suggestion of a planktonic host or possibly host larvae as seen in *Bonamia*, where it can infect the planktonic larval phase of *O. edulis* (Arzul et al., 2011). It also supports the possibility that these parasites were implicated in the host population crashes seen in the Burry Inlet (Elliot et al., 2012; Hartikainen et al., 2014). The same study also highlighted the presence of *H. edule* in 36% of the samples and confirms a pelagic phase of this parasite's lifecycle. *Minchinia* spp. has been positively identified in *Cerastoderma edule* from Galicia, Spain. Results from DNA analysis showed the presence of *M. mercenariae* even though there was no evidence of it in the histological screening of the samples (Ramilo et al., 2018). These findings show how important this form of analysis can be in highlighting a potential problematic pathogen which could otherwise be missed in standard screening procedures. It has also

expanded the known geographic range of these parasites outside of the United States, where it is known to infect *Mercenaria mercenaria* (Ford et al., 2009).

*Minchinia* parasites usually infect the connective tissue of multiple organs in its host (Ramilo et al., 2018). In this study infection was presented in the connective tissues around the digestive area and gonad (Fig. 10c). Due to the covert nature of the parasite, its presence was identified by the arrangement of the cells in among a large foci of haemocyte infiltration (Fig. 10 b & c). In addition, the crypsis nature of *Minchinia* parasites. suggests that if it is present in cockles, it could easily be missed by routine histology. Re-examination of stained tissue sections from *M. mercenaria* has shown that half of the samples that tested positive *Minichina* spp. through the use of molecular methods and polymerase chain reaction (PCR), revealed evidence of small nuclei with centrally located endosomes in the tissues (Ford et al., 2009). Other papers have also reported similar findings when re-examining histology sections for *Bonamia* and *Minchinia* parasites (Burreson et al. 2004; Bearham et al. 2008; Ford et al, 2009). Carballal et al., (2003). These studies have identified areas with large foci of heavy haemocyte infiltration in *C. edule* and related this to the presence of a virus belonging to the family Picornaviridae. Longshaw and Malham (2013) drew attention to the authors' observations of four spherical to elongate cells within the areas of infiltration and accounted for them as probably being the developmental stages of a haplosporidian. Positivity in identifying *Minchinia*, *Haplosporidium* and other *Haplosporidia* has therefore proved challenging in many different species and further research is required to determine their prevalence and impact to the host, particularly in cockles. The infection intensity of *Minchinia* spp. in one of the samples from the Dee estuary would have caused a significant pathological impact and reduction in the cockle's ability to function normally (Fig. 10b), whereas, in another infected cockle, intensity was low in comparison. Genetic analysis can provide data which otherwise may have been missed. It has, for example, facilitated the detection of *Minchinia* spp. in *Mytilus edulis* (Lynch et al., 2014) from the Menai Strait, North Wales, a body of water located between both of our study sites; and it could therefore be suitably applied in future sampling at our study sites.

### ***Haemocytic neoplasia***

Haemocytic neoplasia, otherwise referred to as disseminated neoplasia, is considered to be progressive viral disease spread through indirect transmission in the water column and can become epidemic within a population of cockles (Collins, 1998; Bower, 2009; Diaz et al., 2016). It is characterised by abnormal proliferation of cells (Fig. 10d) and results in significant



tissue damage as a result of infection (Barber, 2004; Longshaw and Malham, 2013). The disease causes normal haemolymph cells to be replaced by neoplastic cells, which no longer function normally (Barber, 2004). Thus, biological processes such as the transportation of nutrients are reduced, as well as causing hypoxia of the haemocytes, are all consequences of infection by this disease. As the abundance of neoplastic cells increases it can result in the death of the bivalve (Barber, 2004). It is found infecting cockles across Europe (Poder & Auffret, 1986; Twomey & Mulcahy, 1988; Villalba et al. 2001; Diaz et al., 2016) and its prevalence can be up to 84% in some cockle populations (Villalba et al., 2001). Spatially haemocytic neoplasia has been found in 29 out of 34 sites sampled in North West Spain, with a mean prevalence of 12% in *C. edule* Carballal et al., (2001), and around the south coast of Ireland where it was distributed throughout Cork harbour, in 10 of the 11 sites sampled and along the exposed coast in 4 of 7 sites sampled (Twomey and Mucahy, 1988). These authors found the prevalence to reach 60% in July when the study was conducted (Twomey and Mucahy, 1988).

Previously, haemocytic neoplasia was observed in Wales from the Burry Inlet in 2009 but prevalence was low at 3% (Elliott et al., 2012). This same study also sampled the Dee estuary however it was not reported to be present. The Burry Inlets prevalence is similar to our findings from Traeth Melynog, and we also did not observe this parasite group from the Dee estuary. At Traeth Melynog it was observed in all of the seasons which goes against some of the findings from other studies that it is a temperature dependant virus (Morgan et al., 2012). However, although our prevalence's were low, the progressive nature of the virus was low in autumn when temperatures were at their lowest and increased in spring when temperatures were near to their highest (Fig. 2). It is also possible that the occurrence of this virus at Traeth Melynog can be associated with the difference in overall sediment temperature that was observed in the results (Table 9). Further research however will be needed to conclude that the slight difference in temperature between sites was responsible for haemocytic neoplasia infection. High prevalence of haemocytic neoplasia can be associated with impaired burrowing capabilities and it has been shown that cockles observed moribund on the sediment surface, had a greater prevalence than those buried under the sediment (Morgan et al., 2012; Diaz et al., 2016). It also has a greater impact to cockles, which are also host to *Bucephalus minimus*. The cockle metabolic cost is increased, thus leading to indirect mortality. For haemocytic neoplasia observed in this study, those infected showed a significant pathological response. As this study only sampled burrowed cockles the prevalence is similar to observations in the Irish seas

around southern Ireland (Morgan et al., 2012). Haemocytic neoplasia can affect the lipid content of the infected host. Blood samples taken from *C. edule* were tested in relation to the infection of the virus and it was observed that those infected with haemocytic neoplasia had a lower proportion of lipids in the membranes of the blood cells and reduce the function of the haemocyte cells in transporting oxygen round the body. (Le Grand et al., 2013).

#### 4.4.3 Summary

This present study assessed the spatial and temporal changes of the community of parasites and pathogens present in *Cerastoderma edule* from cockle beds in North Wales and Western England and furthered our understanding of the microbiota found within them. We have shown that there are at least 17 different groups present within the populations over the course of a year and that there is a small difference in structure between sites. Most do not impact on the individual infected. In the right environmental conditions, however, the groups discussed have the potential to disrupt cockle behaviour, weaken individuals and cause mortality. Fortunately, for these groups (*Bucephalus* spp., *Gymnophallus* spp., *Haplosporidium* spp. and *Minchinia* spp. and the virus Haemocytic neoplasia.), the prevalence and the intensity of infection we observed was never considered to be at a level that would significantly impact the population as a whole, but only at an individual level. Generally, if intensity of infection was high in individuals, as seen in *Haplosporidium* spp., infection was localised to a single site where the general prevalence was low. Their presence, however, should not be ignored and further monitoring is needed to assess whether our findings are representative of other years or seasons. Knowing when and where the most influential parasite species appear in the populations will be useful in the management of these shellfish fisheries. Cockles are rarely infected with a single species and bigger cockles tend to contain more species. Over time a positive relationship develops between cockle size and the parasite and pathogen species richness due to the ongoing exposure, but also as they increase in size, they have a higher filtration rate (de Montaudouin et al., 2012). Quantifying the combined effect of multiple species or groups is extremely difficult but could show connectivity between species and their impact (Babirat et al., 2004). Presence/absence data is good as a general guide but understanding their *actual* host impact is critical for assessing the risk of lethal pathogens given that they may not cause any problem to their host when only present in low numbers. Incorporating quantitative PCR alongside histology screening to assess parasitic community will certainly improve our knowledge of what is present and may show up groups, or increase

## *Chapter 4*

the prevalence of covert groups, which would otherwise been missed (Ford et al., 2009; Ramilo et al., 2018). Lastly, by accurately assessing the environmental conditions, such as temperature and water conditions, and conducting research to determine the drivers behind infection could predict conditions when cockles are most at risk of infection by key species of parasites and pathogens.

## 4.5 References

- Anderson, R.M. and Whitfield, P.J., 1975. Survival characteristics of the free-living cercarial population of the ectoparasitic digenean *Transversotrema patialensis* (Soparker, 1924). *Parasitology*, 70(3), pp.295-310.
- Andrews, J.D., 1984. Epizootiology of diseases of oysters (*Crassostrea virginica*), and parasites of associated organisms in eastern North America. *Helgoländer Meeresuntersuchungen*, 37(1), p.149.
- Arzul, I. and Carnegie, R.B., 2015. New perspective on the haplosporidian parasites of molluscs. *Journal of invertebrate pathology*, 131, pp.32-42.
- Arzul, I., Gagnaire, B., Bond, C., Chollet, B., Morga, B., Ferrand, S., Robert, M. and Renault, T., 2009. Effects of temperature and salinity on the survival of *Bonamia ostreae*, a parasite infecting flat oysters *Ostrea edulis*. *Diseases of aquatic organisms*, 85(1), pp.67-75.
- Arzul, I., Langlade, A., Chollet, B., Robert, M., Ferrand, S., Omnes, E., Lerond, S., Couraleau, Y., Joly, J.P., François, C. and Garcia, C., 2011. Can the protozoan parasite *Bonamia ostreae* infect larvae of flat oysters *Ostrea edulis*?. *Veterinary parasitology*, 179(1-3), pp.69-76.
- Azevedo, C., Conchas, R.F. and Montes, J., 2003. Description of *Haplosporidium edule* n. sp. (Phylum Haplosporidia), a parasite of *Cerastoderma edule* (Mollusca, Bivalvia) with complex spore ornamentation. *European journal of protistology*, 39(2), pp.161-167.
- Babirat, C., Mouritsen, K.N. and Poulin, R., 2004. Equal partnership: two trematode species, not one, manipulate the burrowing behaviour of the New Zealand cockle, *Austrovenus stutchburyi*. *Journal of Helminthology*, 78(3), pp.195-199.
- Barber, R.D., Kanaley, S.A. and Ford, S.E., 1991. Evidence for regular sporulation by *Haplosporidium nelsoni* (MSX) (Ascetospora; Haplosporidiidae) in spat of the American oyster, *Crassostrea virginica*. *The Journal of protozoology*, 38(4), pp.305-306.
- Barber, B.J., 2004. Neoplastic diseases of commercially important marine bivalves. *Aquatic Living Resources*, 17(4), pp.449-466.
- Bearham, D., Spiers, Z., Raidal, S., Jones, J.B. and Nicholls, P.K., 2008. Detection of *Minchinia* sp., in rock oysters *Saccostrea cucullata* (Born, 1778) using DNA probes. *Journal of invertebrate pathology*, 97(1), pp.50-60.
- Bowers, E.A. and James, B.L., 1967. Studies on the morphology, ecology and life-cycle of *Meiogymnophallus minutus* (Cobbold, 1859) comb. nov.(Trematoda: Gymnophallidae). *Parasitology*, 57(2), pp.281-300.
- Bowers, E.A., Bartoli, P., Russell-Pinto, F. and James, B.L., 1996. The metacercariae of sibling species of *Meiogymnophallus*, including *M. rebecqui* comb. nov.(Digenea: Gymnophallidae), and their effects on closely related *Cerastoderma* host species (Mollusca: Bivalvia). *Parasitology Research*, 82(6), pp.505-510.
- Bray, J.R. and Curtis, J.T., 1957. An ordination of the upland forest communities of southern Wisconsin. *Ecological monographs*, 27(4), pp.325-349.
- Burdon, D., Callaway, R., Elliott, M., Smith, T. and Wither, A., 2014. Mass mortalities in bivalve populations: A review of the edible cockle *Cerastoderma edule* (L.). *Estuarine, coastal and shelf science*, 150, pp.271-280.
- Burreson, E.M. and Ford, S.E., 2004a. A review of recent information on the Haplosporidia, with special reference to *Haplosporidium nelsoni* (MSX disease). *Aquatic Living Resources*, 17(4), pp.499-517.
- Burreson, E.M., Stokes, N.A., Carnegie, R.B. and Bishop, M.J., 2004b. *Bonamia* sp.(Haplosporidia) found in non-native oysters *Crassostrea ariakensis* in Bogue Sound, North Carolina. *Journal of Aquatic Animal Health*, 16(1), pp.1-9.

## Chapter 4

- Burreson, E.M., Stokes, N.A. and Friedman, C.S., 2000. Increased virulence in an introduced pathogen: *Haplosporidium nelsoni* (MSX) in the eastern oyster *Crassostrea virginica*. Journal of aquatic animal health, 12(1), pp.1-8.
- Camphuysen, C.J., Berrevoets, C.M., Cremers, H.J.W.M., Dekinga, A., Dekker, R., Ens, B.J., Van der Have, T.M., Kats, R.K.H., Kuiken, T., Leopold, M.F. and Van der Meer, J., 2002. Mass mortality of common eiders (*Somateria mollissima*) in the Dutch Wadden Sea, winter 1999/2000: starvation in a commercially exploited wetland of international importance. Biological conservation, 106(3), pp.303-317.
- Callaway, R. et al., 2013. The riddle of the sands: how population dynamics explains causes of high bivalve mortality. Journal of applied ecology, 50(4), pp.1050–1059.
- Carballal, M.J., Iglesias, D., Santamarina, J., Ferro-Soto, B. and Villalba, A., 2001. Parasites and pathologic conditions of the cockle *Cerastoderma edule* populations of the coast of Galicia (NW Spain). Journal of invertebrate pathology, 78(2), pp.87-97.
- Carballal, M.J., Villalba, A., Iglesias, D. and Hine, P.M., 2003. Virus-like particles associated with large foci of heavy hemocytic infiltration in cockles *Cerastoderma edule* from Galicia (NW Spain). Journal of invertebrate pathology, 3(84), pp.234-237.
- Catanese, G., Grau, A., Valencia, J.M., Garcia-March, J.R., Vázquez-Luis, M., Alvarez, E., Deudero, S., Darriba, S., Carballal, M.J. and Villalba, A., 2018. *Haplosporidium pinnae* sp. nov., a haplosporidan parasite associated with mass mortalities of the fan mussel, *Pinna nobilis*, in the Western Mediterranean Sea. Journal of invertebrate pathology, 157, pp.9-24.
- Clarke, K.R., 1993. Non- parametric multivariate analyses of changes in community structure. Australian journal of ecology, 18(1), pp.117-143.
- Clarke, K.R. and Warwick, R.M., 2001. Change in marine communities. An approach to statistical analysis and interpretation, 2<sup>nd</sup> edition. PRIMER-E: Plymouth Marine Laboratory, UK
- Collins, C., 1998. Studies on a Neoplasm of the Cockle, *Cerastoderma edule* (Linnaeus) (Doctoral dissertation, NUI). Combes, C., 1996. Parasites, biodiversity and ecosystem stability. Biodiversity & Conservation, 5(8), pp.953-962.
- Dabouineau, L. & Ponsero, A., 2009. Synthesis on biology of Common European Cockle *Cerastoderma edule*. Second edition Université Catholique de l'Ouest - Réserve Naturelle Nationale Baie de St-Brieuc, 23 pages.
- Darriba, S., 2017. First haplosporidan parasite reported infecting a member of the Superfamily Pinnoidea (*Pinna nobilis*) during a mortality event in Alicante (Spain, Western Mediterranean). Journal of invertebrate pathology, 148, pp.14-19.
- Da Silva, P.M., Soudant, P., Carballal, M.J., Lambert, C. and Villalba, A., 2005. Flow cytometric DNA content analysis of neoplastic cells in haemolymph of the cockle *Cerastoderma edule*. Diseases of aquatic organisms, 67(1-2), pp.133-139.
- Deltreil, J.P. and His, E., 1970. Sur la présence d'une cercaire de trématode chez *Cardium edule* L. dans le Bassin d'Arcachon. Revue des Travaux de l'Institut des Pêches Maritimes, 34(2), pp.225-232.
- de Montaudouin, X., Bazairi, H. and Culloty, S., 2012. Effect of trematode parasites on cockle *Cerastoderma edule* growth and condition index: a transplant experiment. Marine ecology progress series, 471, pp.111-121
- de Montaudouin, X., Kisielewski, I., Bachelet, G. and Desclaux, C., 2000. A census of macroparasites in an intertidal bivalve community, Arcachon Bay, France. Oceanologica acta, 23(4), pp.453-468.
- de Montaudouin, X., Thieltges, D.W., Gam, M., Krakau, M., Pina, S., Bazairi, H., Dabouineau, L., Russell-Pinto, F. and Jensen, K.T., 2009. Digenean trematode species in the cockle *Cerastoderma edule*: identification key and distribution along the north-eastern Atlantic shoreline. Journal of the marine biological association of the United Kingdom, 89(3), pp.543-556.

## Chapter 4

- de Montaudouin, X., Wegeberg, A.M., Jensen, K.T. and Sauriau, P.G., 1998. Infection characteristics of *Himasthla elongata* cercariae in cockles as a function of water current. *Diseases of aquatic organisms*, 34(1), pp.63-70.
- Desclaux, C., De Montaudouin, X. and Bachelet, G., 2002. Cockle emergence at the sediment surface: 'favourization' mechanism by digenean parasites?. *Diseases of aquatic organisms*, 52(2), pp.137-149.
- Díaz, S., Iglesias, D., Villalba, A. and Carballal, M.J., 2016. Long-term epidemiological study of disseminated neoplasia of cockles in Galicia (NW Spain): temporal patterns at individual and population levels, influence of environmental and cockle-based factors and lethality. *Journal of fish diseases*, 39(9), pp.1027-1042.
- Drummond, L., Mulcahy, M. and Culloty, S., 2006. The reproductive biology of the Manila clam, *Ruditapes philippinarum*, from the North-West of Ireland. *Aquaculture*, 254(1-4), pp.326-340.
- Elliott, M. and Holden, J., 2017. UK Sea fisheries annual statistics. Marine Management Organisation. Available at: [https://assets.publishing.service.gov.uk/government/uploads/system/uploads/attachment\\_data/file](https://assets.publishing.service.gov.uk/government/uploads/system/uploads/attachment_data/file)
- Elliott, M., Burdon, D., Callaway, R., Franco, A., Hutchinson, T., Longshaw, M., Malham, S., Mazik, K., Otto, Z., Palmer, D. and Firmin, C., 2012. Burry Inlet cockle mortalities investigation 2009–2011 (p. 337). Final Technical Report to Environment Agency (Wales), 17 January 2012. Available online at: [http://a0768b4a8a31e106d8b0-50dc802554eb38a24458b98ff72d550b.r19.cf3.rackcdn.com/gewa0112bwap-ee.pdf/742793/UK\\_Sea\\_Fisheries\\_Statistics\\_2017.pdf](http://a0768b4a8a31e106d8b0-50dc802554eb38a24458b98ff72d550b.r19.cf3.rackcdn.com/gewa0112bwap-ee.pdf/742793/UK_Sea_Fisheries_Statistics_2017.pdf)
- Engelsma, M.Y., Roozenburg, I., Voorbergen-Laarman, M., Van den Brink, A., Troost, K., Ysebaert, T., Bateman, K. and Longshaw, M., 2011. Digenean trematodes and haplosporidian protozoans associated with summer mortality of cockles *Cerastoderma edule* in the Oosterschelde, The Netherlands. In European Association of Fish Pathologists Conference, Split, Croatia, 14–18 September 2011.
- Faliex, E., 1991. *Labratrema minimus* metacercariae (Trematoda, Bucephalidae). *Diseases of aquatic organisms*, 10, pp.93-101.
- Faliex, E. and Morand, S., 1994. Population dynamics of the metacercarial stage of the bucephalid trematode, *Labratrema minimus* (Stossich, 1887) from Salses-Leucate lagoon (France) during the cercarial shedding period. *Journal of Helminthology*, 68(1), pp.35-40.
- Feis, M.E., Thieltges, D.W., Olsen, J.L., de Montaudouin, X., Jensen, K.T., Bazaïri, H., Culloty, S.C. and Luttikhuisen, P.C., 2015. The most vagile host as the main determinant of population connectivity in marine macroparasites. *Marine ecology progress series*, 520, pp.85-99.
- Fermer, J., Culloty, S.C., Kelly, T.C. and O'Riordan, R.M., 2010. Temporal variation of *Meiogygnophallus minutus* infections in the first and second intermediate host. *Journal of helminthology*, 84(4), pp.362-368.
- Flannery, G., Lynch, S.A., Longshaw, M., Stone, D., Martin, P., Ramilo, A., Villalba, A. and Culloty, S.C., 2014. Interlaboratory variability in screening for *Bonamia ostreae*, a protistan parasite of the European flat oyster *Ostrea edulis*. *Diseases of aquatic organisms*, 110(1-2), pp.93-99.
- Ford, SE and Barber, RD., 1995. Life cycle studies of *Haplosporidium nelsoni* (msx): spores and non-oyster hosts. NOAA
- Ford, S.E. and Tripp, M.R., 1996. Diseases and defense mechanisms. The eastern oyster *Crassostrea virginica*, pp.581-660.
- Ford, S.E., Stokes, N.A., Bureson, E.M., Scarpa, E., Carnegie, R.B., Kraeuter, J.N. and Bushek, D., 2009. *Minchinia mercenariae* n. sp.(Haplosporidia) in the hard clam *Mercenaria mercenaria*: implications of a rare parasite in a commercially important host. *Journal of eukaryotic microbiology*, 56(6), pp.542-551.
- Freitas, R., Martins, R., Campino, B., Figueira, E., Soares, A.M.V.M. and Montaudouin, X., 2014. Trematode communities in cockles (*Cerastoderma edule*) of the Ria de Aveiro (Portugal): influence of inorganic contamination. *Marine pollution bulletin*, 82(1-2), pp.117-126.

## Chapter 4

- Gam, M., De Montaudouin, X. and Bazairi, H., 2009. Do trematode parasites affect cockle (*Cerastoderma edule*) secondary production and elimination?. *Journal of the marine biological association of the United Kingdom*, 89(7), pp.1395-1402.
- Gam, M., Bazairi, H., Jensen, K.T. and De Montaudouin, X., 2008. Metazoan parasites in an intermediate host population near its southern border: the common cockle (*Cerastoderma edule*) and its trematodes in a Moroccan coastal lagoon (Merja Zerga). *Journal of the marine biological association of the United Kingdom*, 88(2), pp.357-364.
- Garcia, C., Arzul, I., Chollet, B., Ferrand, S., François, C., Joly, J.-P., Miossec, L., Robert, M., 2006. Synthesis of 15 years records for *Haplosporidium nelsoni* in *Crassostrea gigas* in France. *Journal of shellfish research* 25, 728.
- Goss-Custard, J.D. et al., 2004. When enough is not enough: shorebirds and shellfishing. *Proceedings of the royal society London*, 271(1536), pp.233-7.
- Hartikainen, H., Ashford, O.S., Berney, C., Okamura, B., Feist, S.W., Baker-Austin, C., Stentiford, G.D. and Bass, D., 2014. Lineage-specific molecular probing reveals novel diversity and ecological partitioning of haplosporidians. *The ISME journal*, 8(1), p.177.
- Hechinger, R.F., Lafferty, K.D., Huspeni, T.C., Brooks, A.J. and Kuris, A.M., 2007. Can parasites be indicators of free-living diversity? Relationships between species richness and the abundance of larval trematodes and of local benthos and fishes. *Oecologia*, 151(1), pp.82-92.
- Howard, D.W., Lewis, E.J., Keller, B.J. and Smith, C.S., 2004. Histological techniques for marine bivalve mollusks and crustaceans. *NOAA Technical Memorandum NOS NCCOS 5*, pp.218.
- Hudson, P.J., Dobson, A.P. and Lafferty, K.D., 2006. Is a healthy ecosystem one that is rich in parasites?. *Trends in ecology & evolution*, 21(7), pp.381-385.
- Hutton, R.F., 1952. Studies on the parasites of *Cardium edule* L.: *Cercaria fulbrighti* n. sp., a *Gymnophallus* larva with a forked tail. *Journal of the marine biological association of the United Kingdom*, 31(2), pp.317-326.
- Javanshir, A., 2001. Influence of infestation by *Labratrema minimus* (Bucephalidae: Digenea) on oxygen consumption of edible cockle *Cerastoderma edule* (Mollusca: Bivalvia) in laboratory conditions. *Iranian journal of fisheries sciences*, 3(1), pp.39-54.
- Jensen, K.T., Latama, G. and Mouritsen, K.N., 1996. The effect of larval trematodes on the survival rates of two species of mud snails (Hydrobiidae) experimentally exposed to desiccation, freezing and anoxia. *Helgoländer Meeresuntersuchungen*, 50(3), p.327.
- Jensen, K.T. & Jensen, J.N., 1985. The importance of some epibenthic predators on the density of juvenile benthic macrofauna in the Danish Wadden Sea. *Journal of experimental marine biology and ecology*, 89, pp.157-174.
- Jonsson, P.R. and Andé, C., 1992. Mass mortality of the bivalve *Cerastoderma edule* on the Swedish west coast caused by infestation with the digenean trematode *Cercaria cerastodermæ* I. *Ophelia*, 36(2), pp.151-157.
- Kingston, P.F., 1974. Studies on the Reproductive Cycles of *Cardium edule* and *C. glaucum*. *Marine biology*, 28, pp.317-323.
- Lauckner, G., 1983. Diseases of mollusca: bivalvia. *Diseases of marine animals*, 2.
- Lauckner, G., 1984. Impact of trematode parasitism on the fauna of a North Sea tidal flat. *Helgoländer Meeresuntersuchungen*, 37(1), p.185.
- Le Grand, F., Soudant, P., Marty, Y., Le Goïc, N. and Kraffe, E., 2013. Altered membrane lipid composition and functional parameters of circulating cells in cockles (*Cerastoderma edule*) affected by disseminated neoplasia. *Chemistry and physics of lipids*, 167, pp.9-20.
- Longshaw, M. and Malham, S.K., 2013. A review of the infectious agents, parasites, pathogens and commensals of European cockles (*Cerastoderma edule* and *C. glaucum*). *Journal of the marine biological association of the United Kingdom*, 93(1), pp.227-247.

## Chapter 4

- Lynch, S.A., Morgan, E., Carlsson, J., Mackenzie, C., Wooton, E.C., Rowley, A.F., Malham, S. and Culloty, S.C., 2014. The health status of mussels, *Mytilus* spp., in Ireland and Wales with the molecular identification of a previously undescribed haplosporidian. *Journal of invertebrate pathology*, 118, pp.59-65.
- Lynch, S.A., Villalba, A., Abollo, E., Engelsma, M., Stokes, N.A. and Culloty, S.C., 2013. The occurrence of haplosporidian parasites, *Haplosporidium nelsoni* and *Haplosporidium* sp., in oysters in Ireland. *Journal of invertebrate pathology*, 112(3), pp.208-212.
- Magalhães, L., Correia, S., de Montaudouin, X. and Freitas, R., 2018. Spatio-temporal variation of trematode parasites community in *Cerastoderma edule* cockles from Ria de Aveiro (Portugal). *Environmental research*, 164, pp.114-123.
- Magalhães, L., Freitas, R. and De Montaudouin, X., 2015. *Bucephalus minimus*, a deleterious trematode parasite of cockles *Cerastoderma* spp. *Parasitology research*, 114(4), pp.1263-1278.
- Malham, S.K., Hutchinson, T.H. & Longshaw, M., 2012. A review of the biology of European cockles (*Cerastoderma* spp.). *Journal of the marine biological association of the United Kingdom*, 92(07), pp.1563–1577.
- Matthews, R.A., 1973 Life-cycle of *Bucephalus haimeanus* Lacaze-Duthiers, 1854 from *Cardium edule* L. *Parasitology* 67:341–350
- Morgan, E., Lynch, S.A., O'Riordan, R.M. and Culloty, S.C., 2012, April. Comparison of the health status of the common cockle *Cerastoderma edule* at two sites in southern Ireland. In: *Journal of shellfish research* (Vol. 31, No. 1, pp. 325-325). C/O Dr. Sandra E. Shumway, Univ Connecticut, 1080 Shennecossett Rd, Groton, Ct 06340 Usa: Natl Shellfisheries Assoc.
- Morgan, E., O'Riordan, R.M. and Culloty, S.C., 2013. Climate change impacts on potential recruitment in an ecosystem engineer. *Ecology and evolution*, 3(3), pp.581-594.
- Morgan, E., Riordan, R.O., Kelly, T.C. and Culloty, S.C., 2012. Influence of disseminated neoplasia, trematode infections and gametogenesis on surfacing and mortality in the cockle *Cerastoderma edule*. *Diseases of aquatic organisms*, 98(1), pp.73-84.
- Mouritsen, K.N. and Poulin, R., 2002. Parasitism, community structure and biodiversity in intertidal ecosystems. *Parasitology*, 124(7), pp.101-117.
- Newell, R.I.E. and Bayne, B.L., 1980. Seasonal changes in the physiology, reproductive condition and carbohydrate content of the cockle *Cardium* (= *Cerastoderma*) *edule* (Bivalvia: Cardiidae). *Marine biology*, 56(1), pp.11-19.
- Norris, K., Bannister, R. & Walker, P., 1998. Changes in the number of oystercatchers *Haematopus ostralegus* wintering in the Burry Inlet in relation to the biomass of cockles *Cerastoderma edule* and its commercial exploitation. *Journal of applied ecology*, 35, pp.75–85.
- Ordás, M.C. and Figueras, A., 2005. Histopathological study of abnormal mortalities of cockle (*Cerastoderma edule*) in Carril (Galicia, NW Spain). *Bulletin of the European association of fish pathologists*, 25, pp.124-130.
- Pechenik, J.A. and Fried, B., 1995. Effect of temperature on survival and infectivity of *Echinostoma trivolvis* cercariae: a test of the energy limitation hypothesis. *Parasitology*, 111(3), pp.373-378.
- Pina, S., Barandela, T., Santos, M.J., Russell-Pinto, F. and Rodrigues, P., 2009. Identification and description of *Bucephalus minimus* (Digenea: Bucephalidae) life cycle in Portugal: morphological, histopathological, and molecular data. *Journal of parasitology*, 95(2), pp.353-359.
- Poder, M. and Auffret, M., 1986. Sarcomatous lesion in the cockle *Cerastoderma edule*: I. Morphology and population survey in Brittany, France. *Aquaculture*, 58(1-2), pp.1-8.
- Poulin, R., 1999. The functional importance of parasites in animal communities: many roles at many levels?. *International journal for parasitology*, 29(6), pp.903-914.
- Poulin, R., & Cribb, T.H. (2002). Trematode life cycles: short is sweet? *Trends in parasitology*, 18 4, pp.176-83.



## Chapter 4

- Presta, M.L., Cremonte, F. and Ituarte, C., 2014. The fit between parasites and intermediate host population dynamics: larval digeneans affecting the bivalve *Neolepton cobbi* (Galeommatoidea) from Patagonia. *Marine biology research*, 10(5), pp.494-503.
- Ramilo, A., Abollo, E., Villalba, A. and Carballal, M.J., 2018. A *Minchinia mercenariae*-like parasite infects cockles *Cerastoderma edule* in Galicia (NW Spain). *Journal of fish diseases*, 41(1), pp.41-48.
- Reece, K.S., Siddall, M.E., Stokes, N.A. and Burreson, E.M., 2004. Molecular phylogeny of the Haplosporidia based on two independent gene sequences. *The journal of parasitology*, pp.1111-1122
- Reise, K., 1985. Tidal flat ecology. An experimental approach to species interaction. *Ecological studies*, 61, p.191.
- Robledo, J.A.F., Marquis, N.D., Countway, P.D., Record, N.R., Irish, E.L., Schuldt, M.M., Kingston, S.E., Bishop, T.J., Messerman, N.A. and Bowden, T.J., 2018. Pathogens of marine bivalves in Maine (USA): A historical perspective. *Aquaculture*.
- Rohde, K., 1993. *Ecology of marine parasites: An introduction to marine parasitology* (No. Ed. 2). CAB international.
- Russell-Pinto, F., Gonçalves, J.F. and Bowers, E., 2006. Digenean larvae parasitizing *Cerastoderma edule* (bivalvia) and *Nassarius reticulatus* (gastropoda) from Ria de Aveiro, Portugal. *Journal of parasitology*, 92(2), pp.319-332.
- Sassa S, Watabe Y, Yang S, Kuwae T (2011) Burrowing Criteria and Burrowing Mode Adjustment in Bivalves to Varying Geoenvironmental Conditions in Intertidal Flats and Beaches. *PLoS ONE* 6(9): e25041. <https://doi.org/10.1371/journal.pone.0025041>
- Seed, R. & Brown, R., 1977. A comparison of reproductive cycles of *Modiolus modiolus* (L.), *Cerastoderma* (= *Cardium*) *edule* (L.), and *Mytilus edulis* (L.) in Strangford Lough, Northern Ireland. *Oecologia*, 30, pp.173–188.
- Thieltges, D.W., 2006. Parasite induced summer mortality in the cockle *Cerastoderma edule* by the trematode *Gymnophallus choledochus*. *Hydrobiologia*, 559(1), pp.455-461.
- Thieltges, D.W. and Reise, K., 2006. Metazoan parasites in intertidal cockles *Cerastoderma edule* from the northern Wadden Sea. *Journal of sea research*, 56(4), pp.284-293.
- Thomas, F. & Poulin, R. (1998) Manipulation of a mollusc by a trophically transmitted parasite: convergent evolution or phylogenetic inheritance? *Parasitology* 116, 431–436.
- Twomey, E., 1994. Distribution of sarcoma in the cockle, *Cerastoderma edule*, around the Irish Coast, 1982-91: Implications for pollution etiology. *Invertebrate Neoplasia: Initiation and Promotion Mechanisms*. US Department of Commerce, Woods Hole, MA, pp.3-5.
- Twomey, E. and Mulcahy, M.F., 1988. Epizootiological aspects of a sarcoma in the cockle *Cerastoderma edule*. *Diseases of aquatic organisms*, 5(3), pp.225-238.
- Tyler-Walters, H., 2007. *Cerastoderma edule* Common cockle. In Tyler-Walters H. and Hiscock K. (eds) *Marine Life Information Network: Biology and Sensitivity Key Information Reviews*, [on-line]. Plymouth: Marine biological association of the United Kingdom. [cited 11-09-2018]. Available from: <https://www.marlin.ac.uk/species/detail/1384>
- Vázquez-Luis, M., Álvarez, E., Barrajón, A., García-March, J.R., Grau, A., Hendriks, I.E., Jiménez, S., Kersting, D., Moreno, D., Pérez, M. and Ruiz, J.M., 2017. SOS *Pinna nobilis*: a mass mortality event in western Mediterranean Sea. *Frontiers in marine science*, 4, p.220.
- Veer, H.W. Van Der, Feller, R.J. & Weber, A., 1998. Importance of predation by crustaceans upon bivalve spat in the intertidal zone of the Dutch Wadden Sea as revealed by immunological assays of gut contents. *Journal of experimental marine biology and ecology*, 231, pp.139–157.
- Villalba, A., Carballal, M.J. and López, C., 2001. Disseminated neoplasia and large foci indicating heavy haemocytic infiltration in cockles *Cerastoderma edule* from Galicia (NW Spain). *Diseases of aquatic organisms*, 46(3), pp.213-216.

## Chapter 4

Villalba, A., Carballal, M.J., López, C., Cabada, A., Corral, L. and Azevedo, C., 1999. Branchial rickettsia-like infection associated with clam *Venerupis rhomboides* mortality. *Diseases of aquatic organisms*, 36(1), pp.53-60.

Wegeberg, A.M. and Jensen, K.T., 2003. In situ growth of juvenile cockles, *Cerastoderma edule*, experimentally infected with larval trematodes (*Himastha interrupta*). *Journal of sea research*, 50(1), pp.37-43.

West, A.D., Yates, M.G., McGrorty, S. and Stillman, R.A., 2007. Predicting site quality for shorebird communities: A case study on the Wash embayment, UK. *Ecological modelling*, 202(3-4), pp.527-539.

Whitton, T., 2013. Processes controlling spatial and temporal variations in cockle *Cerastoderma edule* (L.) abundance and distribution, Bangor University, pp.123.

## **Spatial and seasonal variation in the Cellular Energy Allocation of *Cerastoderma edule* (L.) from two cockle fisheries in North Wales, United Kingdom**

### **5. Abstract**

Organisms that inhabit intertidal and estuarine environments must deal with natural, but potentially extreme fluctuations in environmental conditions including; temperature, salinity, food availability and exposure on a daily and seasonal cycle. These natural stressors have the capacity to alter the energy status of organisms living within these environments. The molluscan species *Cerastoderma edule* can withstand such environmental pressures and thrive, however exposure to stressors will disrupt their energy allocation. Changes at the cellular level will affect their physiological response and could potentially be detrimental to their survival. For example, during colder conditions and low food availability, cockles utilise stores of energy in order to survive, resulting in lower body mass. In this study, the energy status from 128 cockles collected from two distinctly different fisheries in North Wales (Dee estuary: Dee & Traeth Melynog: TM) at four-time intervals, were measured using the Cellular Energy Allocation (*CEA*) methodology to identify changes in their energy stores between the two fisheries over a seasonal cycle (autumn 2014 – summer 2015). Tissue samples using half the cockle were homogenised to provide a total *CEA* status is calculated by the ratio of the energy available (*Ea*) (which is the total cellular content of the biochemical components carbohydrate, lipid and protein), and the energy consumed (*Ec*) (measured by the electron transport enzyme activity (ETS)). The energetic condition of cockles originating from TM was greater and they had more energy available to them compared to cockles from the Dee. The largest differences were observed in the winter and summer 2015. The rate at which this energy was metabolized (*Ec*) did not differ between the sites or over seasons, however an inverse relationship with cockle size was found. Cockles from TM showed unexpectedly high *CEA* during the winter sampling and was a result of elevated lipid content, peaking during the winter and summer, but remaining constant in cockles originating from the Dee. Carbohydrate content did not show much variation between sites, except during the spring where cockles from TM displayed higher values. Protein content remained the same between sites over the duration of the study. For all biochemical components, the variation in values was high, indicating a large range in the total energy available between individual cockles, but this does not necessarily follow expected seasonal patterns. Future research should consider larger sample size and target

specific tissues for analysis and increase sampling frequency to provide greater knowledge on the seasonal and site-specific patterns. Detailed monitoring of environmental data would also assist in associating stressors with changes to the energetic condition of cockles.

### 5.1.1 Introduction

Estuarine and intertidal habitats are dynamic and variable in nature and can be subject to environmental extremes on a large scale. These extremes place an increased amount of stress upon the organisms living in these habitats (Kinne, 1971; Erk et al., 2012<sup>a</sup>) which requires them to adapt to contrasting conditions and survive for short periods of time outside their optimal range for abiotic stress factors e.g. exposure to air, hypoxia/anoxia or climate-related changes (Callaway et al., 2012; Rowley et al., 2014). It is therefore challenging and energy-consuming for species living in these habitats to maintain their metabolic rate particularly if abiotic stress factors are coupled (Verslycke and Janssen, 2002). *Cerastoderma edule* is a successful inhabitant of muddy and sandy habitats found along estuaries and intertidal areas. They are adapted like other similar bivalve species (Hawkins and Bayne, 1992; Erk et al., 2012<sup>a</sup>) to deal with the extreme environmental conditions (e.g. temperature, salinity and dissolved oxygen) which are experienced over both daily and seasonal cycles (Boyden 1972; Brock 1979; Wolff et al. 1993; Ramon, 2003; Reise 2003; Compton et al. 2007; Genelt-Yanovski et al. 2010) and which can cause important changes in the energy metabolism of these organisms (Verslycke and Janssen, 2002).

An organism's energy acquisition and expenditure can be measured using its physiological traits (i.e. feeding, respiration, excretion etc.) and integrating these by means of physiological energetics to provide an insight of their response to the environment (Bayne and Newell, 1983; Widdows and Johnson, 1988). It can be assumed that exposure to a stressor will disrupt energy allocation in an organism and, as such, the effect and anatomical change at the cellular level interferes with the organism's physiological responses (Bagheri et al., 2010). Organisms can mobilize their energy reserves to deal with stressful conditions, e.g. during periods of exposure to, and extremes in, temperature fluctuations. For example, during a diurnal cycle, cockles must twice withstand the falling tide and use up energy to burrow into the sediment to escape desiccation and predation. During this period of exposure, the opportunity for feeding and respiration are reduced, and this limits the time available to replenish the energy that has been lost. At a seasonal scale, in late spring and early summer,

cockles go through gametogenesis and there is a high metabolic cost involved in ensuring successful reproduction (Calow and Silby, 1990). Cockles must build up their energy reserves, in particular lipids, to meet this seasonal metabolic demand. Post-spawning, these metabolic costs are reduced, which – taken together with the high abundance of seasonal food – allows *C. edule* to replenish its carbohydrate and lipid reserves. During the colder months of winter and early spring, when food availability is significantly reduced, cockles will utilise these reserves of carbohydrates, proteins and lipids and a reduction in body mass may be observed (Newell & Bayne, 1980).

Toxic stress induces metabolic changes in organisms; e.g. from abiotic factors such as pollution (Smolders et al., 2004), where there is a metabolic cost for detoxification or biotic factors such as the impact of pathogens (Zhang et al., 2019), where the host needs to put energy into repairing the cellular damage. Mitigating against a reduction in its burrowing ability or fighting against viruses will also demand higher metabolic costs than usual. This may lead to adverse effects on growth and reproduction (Calow and Silby, 1990).

As a way of measuring toxic stress in marine organisms, the Cellular Energy Allocation (*CEA*) methodology was developed as a biomarker technique to assess the effect of toxic stress on an organism's energy status. This short-term assay is based on the biochemical assessment of changes in energy reserves over time, arrived at by measuring total carbohydrate, protein and lipid content. By taking the sum value of the three biochemical components, it provides a measure of the total energy available (*E<sub>a</sub>*) to the organism. The advantage of this technique is that it also provides an in-situ measure of energy status, by way of measuring the organism's energy consumption (*E<sub>c</sub>*) (assessed by measuring cellular electron transport activity: De Coen and Janssen, 1997). The *CEA* of the organisms can then be calculated by dividing the energy available (*E<sub>a</sub>*) by the energy consumed (*E<sub>c</sub>*) and provide a net energy status of the organism. Prior to its introduction, the usual approach for determination of metabolic rate was through laboratory-based experiments measuring a whole animal's rate of oxygen uptake, achieved by exposing it to a complete range of different conditions that may affect respiration. The benefit of using *CEA* methodology is that it yields rapid and instantaneous in-situ measurements of the organism of interest (provided animals are rapidly frozen upon collection). It also increases the total number of samples that can be quantified due to the time and space required by other methods. It also improves accuracy by assessing performance in the natural environment (Widdows and Donkin, 1992; De Coen and Janssen, 1997), thus removing the need for laboratory experimentations.

Over the years the *CEA* methodology has been applied on a range of different marine and freshwater organisms since 1997 when it was first introduced by De Coen and Janssen, (1997) (Table 1) and has been established as a good marker of exposure to natural stress (De Coen and Janssen, 2003). Originally developed to assess the energy allocation in *Daphnia magna* exposed to sublethal concentrations of lindane and mercuric chloride (De Coen and Janssen, 1997), it has subsequently been used – by way of three examples – as a physiological biomarker to infer the occurrence of natural stress in native populations of mussels (*Mytilus galloprovincialis*) (Erk et al., 2012); for assessing the impact of exposure to tributyltin in the estuarine mud shrimp *Neomysis integer* (Verslycke et al., 2003); and for assessing the physiological and organismal endpoints of the freshwater zebra mussel (*Dreissena polymorpha*) to exposure along a pollution gradient (Smolders et al., 2004) (Table 1). Table 1 shows all studies since 1997 that have taken the *CEA* approach to investigate the effect of different stressors or contaminants (natural and man-made) on aquatic organisms.

### 5.1.2 Aims and Hypothesis

To help understand the impact natural stressors have on the condition of cockles it is important to measure the energy status of wild stocks using the *CEA* approach. The main aim of this study is to use *CEA* methodology as a tool to investigate the spatial and temporal variability of the energy status in native populations of *Cerastoderma edule* from two locations in North Wales, UK. It addresses the question how the energy available to the cockles, changes between two sampling sites over a seasonal scale. This study hypothesises that there will be changes in the energy between the two sites due to the natural variation of environmental conditions associated with seasonality, with a higher energy status occurring in seasons offering favourable conditions for survival, i.e. those which experience warmer temperatures and provide a greater availability of their food source.

## Chapter 5

Table. 1. Review of the studies that has used CEA methodology to investigate the biochemical composition of organisms that are found in an aquatic environment.

Reference	Zoological Group	Species	Environment	Location	Stressor	Endpoint of study
De Coen and Janssen, 1997	Cladocera	<i>Daphnia magna (Juv.)</i>	Freshwater	Laboratory	Lindane and mercury chloride	Toxic stress
Muysen et al., 2002		<i>Daphnia magna</i>	Freshwater	Netherlands	Zinc (Zn) contamination	Determine interclonal variation in zinc tolerance
Verslycke and Janssen, 2002	Mysidacea	<i>Neomysis integer</i>	Marine	Netherlands	Temperature, salinity, dissolved oxygen	Organism response to natural environmental conditions
De Coen and Janssen, 2003	Cladocera	<i>Daphnia magna</i>	Freshwater	Laboratory	CdCl <sub>2</sub> , K <sub>2</sub> Cr <sub>2</sub> O <sub>7</sub> , tributyltin chloride, linear alkylbenzene sulfonic acid, sodium pentachlorophenolate, and 2,4-dichlorophenoxyacetic acid	Toxic stress
Verslycke et al., 2002	Mysidacea	<i>Neomysis integer</i>	Marine	Antwerp, Belgium	Tributyltin (TBT)	Abiotic stress of TBT exposure
Verslycke et al., 2003		<i>Neomysis integer</i>	Marine	Antwerp, Belgium	Testosterone, flutamide, ethinylestradiol, precocene, nonylphenol, fenoxycarb, and methoprene	Acute toxicity to exposure
Verslycke et al., 2004		<i>Neomysis integer</i>	Marine	Antwerp, Belgium	Chlorpyrifos (pesticide)	Exposure/Toxic Stress
Rueda-Jasso et al., 2004	Actinopterygii Pleuronectiformes	<i>Solea senegalensis (Juv.)</i>	Marine	Portugal	Diet	Effect on growth, oxidative status and condition
Smolders et al., 2004	Bivalvia	<i>Dreissena polymorpha</i>	Freshwater	Belgium	Environment and pollution	Spatial variability
Verslycke et al., 2004	Mysidacea	<i>Neomysis integer</i>	Marine	Netherlands	Environmental effects	Temporal and spatial variability
Canli 2005	Cladocera	<i>Daphnia magna</i>	Freshwater	Laboratory	Zinc contamination	Zinc tolerance
Voets et al., 2006	Bivalvia	<i>Dreissena polymorpha</i>	Freshwater	Flanders, Belgium	Trace metals: polychlorinated biphenyls (PCBs), polybrominated diphenyl ethers (PBDEs), di(p-chlorophenyl) dichloroethylene (p,p_-DDE)	Physiological condition and bilateral asymmetry of shells
Olsen et al., 2007	Amphipods	<i>Gammarus setosus</i>	Marine	Svalbard, Norway	Oil-related compounds	Organism response to exposure
	Bivalves	<i>Onisimus litoralis</i> <i>Liocyma fluctuosa</i>				
Moolman et al., 2007	Gastropoda	<i>Melanoides tuberculata</i> <i>Helisoma duryi</i>	Freshwater	South Africa	Cadmium and Zinc exposure	Uptake and organism response

## Chapter 5

Erk et al., 2008	Mysidacea	<i>Neomysis integer</i>	Marine	Antwerp, Belgium	Cadmium and Salinity concentrations	Organism response to exposure
Yeats et al., 2008	Bivalvia	<i>Mytilus edulis</i> <i>Mytilus trossulus</i>	Marine	Nova Scotia, Canada	Polycyclic aromatic hydrocarbons (PAH), dichlorophenyltrichloroethane (DDT family), coprostanol and elements	Biological response
Gagné et al., 2008		<i>Mya arenaria</i>	Marine	Québec, Canada	Tributyltin and dibutyltin	Toxicity
Olsen et al., 2008	Amphipoda	<i>Gammarus wilkitzkii</i>	Marine	Arctic Ocean	Oil	Organism response to exposure
Meyer and Wepener, 2008	Actinopterygii Cichliformes	<i>Oreochromis mossambicus</i>	Freshwater	Mosambique, Africa	Zinc	Uptake and concentrations
Whitlow et al., 2008	Actinopterygii Siluriformes Actinopterygii Characiformes	<i>Clarias gariepinus</i> , <i>Clarias ngamensis</i> , <i>Hydrocynus vittatus</i>	Freshwater	Botswana, Africa		Interspecific differences
Vandenbrouck et al., 2009	Cladocera	<i>Daphnia magna</i>	Freshwater	Cloned, laboratory	Nickel and binary metal (Cadmium and Lead)	Organism response to exposure
Simčič et al., 2010	Isopoda	<i>Ligia italic</i> <i>Titanethes albus</i>	Marine & Freshwater	Ljubljana, Slovenia	Metabolic rate and oxygen consumption	Organism response to exposure *
Nahrgang et al., 2010	Actinopterygii Gadiformes	<i>Boreogadus saida</i>	Marine	Svalbard, Norway	Environmental and Physiological parameters	Seasonality and temporal variation
Nygård et al., 2010	Amphipoda	<i>Onisimus litoralis</i>	Marine	Svalbard, Norway	Physiological parameters	Seasonality
Macrae et al., 2009	Polychaeta	<i>Arinicola marina</i>	Marine	Oslo, Norway	Contaminated sediment	Organism response to exposure
Erk et al., 2011	Bivalvia	<i>Mytilus galloprovincialis</i>	Marine	Krka River estuary, Croatia	Salinity	Effect on tissue type
Erk et al., 2012 <sup>b</sup>			Marine		Natural biomarker of stress for whole animal	Spatial variation
Wang et al., 2012		<i>Chlamys farreri</i>	Marine	Qingdao, China	Exposure to ammonia-N and <i>Vibrio anguillarum</i>	Temporal variation on tissue type
Beyer et al., 2013	Actinopterygii Gadiformes	<i>Mytilus edulis</i> <i>Gadus morhua</i>	Marine	Hammerfest, Norway	Biologically treated wastewater	Response to exposure*
Giarratano et al., 2013	Actinopterygii Gadiformes	<i>Mytilus edulis</i> <i>Chlamys islandica</i> <i>Gadus morhua</i>	Marine	Tromsø, Norway	Biological and Physiological biomarkers	Seasonality



## Chapter 5

De Troch et al., 2013	Actinopterygii Gadiformes Amphipoda Decapoda	<i>Gadus morha</i> <i>Trisopterus luscus</i> <i>Jassa herdmani</i> <i>Pisidia longicornis</i>	Marine	Belgian	Proximity to wind farm	Predator/prey response
Van Cauwenberghe et al., 2015	Bivalvia Polychaeta	<i>Mytilus edulis</i> <i>Arinicola marina</i>	Marine	France, Belgium, Netherlands	Ingestion and translocation of Microplastics	Organism Response to exposure
Sung et al., 2016	Bivalvia	<i>Ruditapes philippinarum</i>	Marine	Korea	crude oil	Organism response to environmental contamination
Kühnhold et al., 2017	Echinodermata	<i>Holothuria scabra</i>	Marine	Lombok, Indonesia	Thermal stress	Organism response to exposure
Abe et al., 2018	Actinopterygii Cypriniformes	<i>Danio rerio</i>	Freshwater	Laboratory	Synthetic dye	Neurotoxicity and behaviour of organism
Bartlett et al., 2018	Bivalvia	<i>Saccostrea glomerata</i> , <i>Ostrea angasi</i> <i>Crassostrea gigas</i> <i>Mytilus galloprovincialis</i> <i>Anadara trapezia</i>	Marine	Australia	Environmental parameters	Seasonality and organism response
Louise et al., 2019		<i>Dreissena polymorpha</i> <i>Dreissena rostriformis bugensis</i>	Freshwater	Moselle River, France	Cadmium (Cd)	Comparison between species
Zhang et al., 2019		<i>Crassostrea gigas</i>	Marine	Aquaculture, Qingdao, China	Thermal and pathogenic stress	Gene expression and organism response

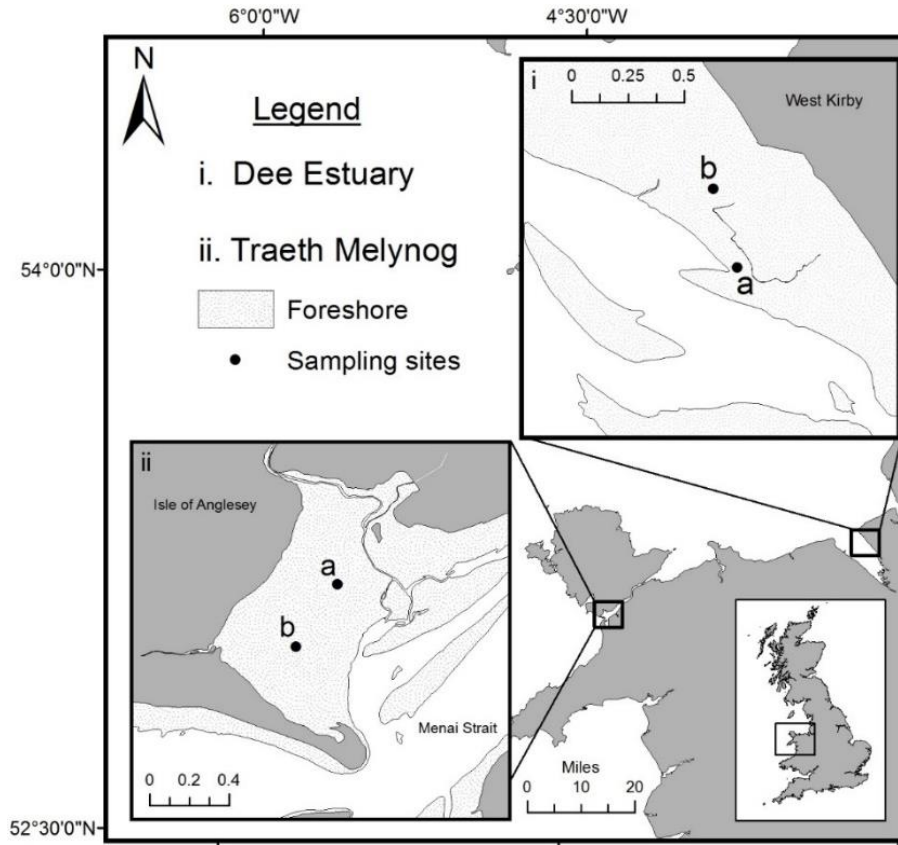
\*Denotes that the study does not specifically mention CEA but uses similar analysis.

## 5.2 Methods

### 5.2.1 Sampling

*Cerastoderma edule* used in the CEA analysis were collected at low-tide from two intertidal mudflats in North Wales, UK. West Kirby, in the Dee Estuary (Dee) and at Traeth Melynog (TM) on the southern end of the Menai Strait, Isle of Anglesey (Fig. 1). Sampling methodology was the same as in Chapter 4 as the cockles collected were used for both studies. Each site was visited 4 times between the autumn of 2014 through to the autumn of 2015 (corresponding to 3-4 months between the sampling periods). Each site was arbitrarily divided into two beds, a and b (Fig. 1.). The distance between these beds was approximately 600 m and lay along the mid shore line. Cockles were collected from five randomly placed 0.1 m<sup>2</sup> quadrats within a 10-metre radius of the fixed GPS position. The sediment inside each quadrat was excavated with a small trowel down to a depth of 5 cm and washed through a 1 mm sieve to extract the infauna. All living cockles present in the sieve were placed in clear plastic bags and transported back to the laboratory on ice.

On arrival at the laboratory, the cockles from each quadrat were blot dried with paper towel and the wet weight of the whole animal, including shell, was recorded to the nearest 3 decimal places. Shell Length (SL), Shell Height (SH) and Shell Width (SW) were measured to the nearest 0.01 mm using Moore and Wright digital callipers (model 110-DBL,  $\pm$ 0.03 mm accuracy). Using a scalpel, the shell was gently prized open and the adductor muscles severed to open the cockle and expose the tissue. Each individual was cut into two halves directly down the medial line of the foot. One half of the cockle was placed into 2 ml Eppendorf tubes, flash frozen in liquid nitrogen and stored at -80°C. Eight random cockles of >20mm SL size class were selected from each bed per site (totalling 16 individuals per site) from each of the sampling seasons that were used in the CEA analysis.



**Figure 1.** Sampling locations for the collection of *Cerastoderma edule* used for Cellular Energetic Analysis in two cockle fisheries along the western shores of the United Kingdom, i) Dee Estuary &, ii) Traeth Melynog, North Wales.

**Table 2:** Location and date of the sampling periods (dd/mm/yyyy).

Site	Fixed GPS position	Autumn 2014	Winter 2014/15	Spring 2015	Summer 2015
DEE A	53.35641 N 03.18817 W	26/10/2014	17/02/2015	10/06/2015	21/09/2015
DEE B	53.36142 N 03.19085 W	26/10/2014	17/02/2015	10/06/2015	21/09/2015
TM A	53.140051 N 04.3314204 W	22/10/2014	10/02/2015	11/05/2015	23/09/2015
TM B	53.135417 N 04.3361629 W	22/10/2014	10/02/2015	11/05/2015	23/09/2015

### 5.2.2 *Sample preparation*

All samples were removed from their tubes and quickly using a pestle and mortar ground to a fine dust in liquid nitrogen to prevent the sample from defrosting and to aid breaking down the tissue. The whole sample was then placed back in the original Eppendorf tube and into the -80°C freezer. For every sample, three new Eppendorf tubes were labelled and individually pre-weighed using analytical balance to 5 decimal places. This was so to ensure that each cockle provided three tissue samples (triplicate). Samples were removed from the freezer in batches ( $n=8$ ) to keep time away from the freezer to a minimum and placed on ice to keep them cold. Three subsamples of homogenised tissue, weighing between 10-20 mg of was measured out in Eppendorf tubes. Actual tissue weight was calculated by subtracting the tube weight from the reading on the balance. Once each batch was complete, the Eppendorf tubes were re-frozen in liquid nitrogen and returned to the -80°C freezer until the biochemical analysis was ready to commence.

### 5.3 *Biochemical Analysis - Cellular Energy Allocation*

The cellular energy allocation was conducted following the methodology developed by De Coen and Janssen (1997) with modifications by Erk et al. (2012). The energy fractions, carbohydrate, lipid and protein, were measured using a spectrophotometer and converted into energy equivalent using Gnaiger (1983) energy of combustion values; glycogen 17500 mJ mg, protein 24000 mJ mg, lipid 39500 mJ mg (Gnaiger, 1983). Energy consumed ( $E_c$ ) was calculated by measuring the electron transport system enzyme activity (ETS). Each biochemical assay was conducted using all three tissue subsamples from each of the 8 individuals selected from each site, bed and season (e.g. Dee, bed A, autumn). All tissue samples were processed in triplicate and the overall mean value was calculated for each individual cockle.

#### 5.3.1 *Carbohydrate Analysis*

A dilutant of 2:1 (5%:15%) trichloroacetic acid (TCA) stock solution was made up prior to the start of the analysis and refrigerated. Total carbohydrate concentration was determined by homogenising each sample in 100µl of 15% (v: w) TCA at room temperature. Once all samples were homogenised, they were placed on ice and incubated for 10 min to precipitate out the proteins. They were then centrifuged at 1000 g in 4°C for 10 min to separate the tissue

from the supernatant. Upon cycle competition, the supernatants were carefully transferred into new tubes preventing any transfer of tissue and stored back on ice. The remaining tissue and pellets were re-suspended with 200  $\mu$ l 5% (v/w) TCA and returned to the centrifuge for another 10-minute cycle at 1000 g and 4°C. Both supernatants were combined and mixed thoroughly for 10 seconds using a vortex. During the centrifuge cycles the glycogen standards were made by diluting glycogen with the TCA stock solution to concentrations of 2000, 1500, 1000, 750, 500, 250, 125, 25, and 0  $\mu$ g ml<sup>-1</sup>. 100  $\mu$ l of each of the supernatant mixture and standards were transferred into clean glass tubes, and 400  $\mu$ l of ice cold 0.2% anthrone-sulphuric acid solution (20 mg anthrone to 10ml 95-98% sulphuric acid) was added. Each sample was again mixed using a vortex for 10 s and incubated on a heating block at 95°C for 5 min, followed by a cool water bath for 5 min (Seifter et al. 1950). Once cooled, the resulting mixture from the samples and standards was added in triplicate to a 96 well plate and read on a spectrophotometer and the absorbance read at the wavelength 620nm (Seifter et al. 1950; Leyva et al. 2008). Due to the high concentration of carbohydrates in the sample, 25  $\mu$ l of supernatant was transferred into clean glass tubes and combined with another 75  $\mu$ l of the dilutant TCA (15%) so the carbohydrates were within the limit of the spectrometer and could be read. All readings were then multiplied by three to get the total mJ ml in each sample. Total carbohydrate concentration was calculated using the linear equation derived from the known glycogen standard concentrations.

### 5.3.2. Protein Analysis

A Pierce™ BCA Protein Assay Kit (Thermo-Scientific™) was used for protein analysis, Total protein concentration was determined by homogenising each sample in ice cold 400 $\mu$ l 0.1M Tris-HCL buffer solution (pH8.5). Samples were then placed in a centrifuge at 1000 g for 10 min to separate the tissue from the supernatant. During this time, standards were made up by diluting the protein stock (Bovine Serum Albumin) with 0.1M Tris-HCL (2 mg/ml) to achieve protein concentrations of 2000, 1500, 1000, 750, 500, 250, 125, 25, and 0 mg ml<sup>-1</sup>. The standards were then kept in the refrigerator until required. 10  $\mu$ l of supernatant from each sample and standard was transferred in triplicate to a 96 well pate. The Working reagent was made in accordance to instructions on the BCA protein kit and was freshly made for each batch of samples. BCA (bicinchoninic acid) solution was made using a 50:1 ratio of reagent A (BCA, sodium carbonate, sodium tartrate and sodium bicarbonate in 0.1M sodium hydroxide, pH 11.25): reagent B (4% w/v copper (II) sulphate pentahydrate). 200 microliters of the working reagent was then added to each of the 96 wells, gently mixed for 30 s then placed in an incubator

at 37°C for 30 min. Absorbance was read on a spectrophotometer at the wavelength 620 nm. Total protein concentration was calculated using the linear equation derived from the known BSA standard concentrations.

### 5.3.3. *Lipid Analysis*

Prior to analysis the reagents were made up in accordance to the sulpho-phospho-vanillin (SPV) assay. Standards were made by diluting cholesterol stock with 2:1 chloroform: methanol solution to achieve cholesterol concentrations of 2000, 1500, 1000, 750, 500, 250, 125, 25, and 0 mg ml<sup>-1</sup>. Total lipid concentration was determined by homogenising each sample in 400 µl of deionised water for 10 s. 40 microliter subsamples were transferred to a new Eppendorf tube then 300 µl of a 2:1 chloroform: methanol solution was added and mixed using a vortex for 10 s, then left to incubate at room temperature for 15 min. After the 15 min incubation, the samples were centrifuged at 10,000 g at 4°C for 20 minutes to separate out a chloroform layer containing the lipids from the aqueous solution. 180 microliters of the lower chloroform phase plus the extracted lipid was carefully extracted and transferred into glass tubes (Bligh and Dyer 1959). The tubes were then incubated at 60°C for 40 min, or until all chloroform had evaporated and a dry layer at the bottom of the tube remained. Tubes were then removed from the incubator and left to cool. 200 microliters of concentrated sulphuric acid was added into each tube and vortex for 30 s then incubated for a further 10 min at 95°C. Tubes were left to cool for 20 min after which 20 µl (triplicate) of each sample was transferred to a 96 well plate and taken to a dark room. Using a red light, 300 µl of the 8 mM phospho-vanilin solution was added and the samples allowed to incubate in a dark box for 40 min to change colour. Absorbance was read using a spectrophotometer at 530 nm.

### 5.3.4. *Electron Transport System (ETS) Analysis*

Prior to analysis all samples were placed on ice. ETS activity was determined by homogenising each sample in 400 µl of homogenate buffer (0.1M Trisma base, 1.5g polyvinylpyrrolidone (PVP), 2 ml Triton x-100 (0.2% v/v), 75 µl MgSO<sub>4</sub> (9 mg/1000 ml, pH8.5) for 10 s, then placed back on ice to keep cool. After all samples had been homogenised, they were placed in a centrifuged at 1000 g in 4°C for 10 min. Once the cycle was complete the supernatants from each sample were transferred into new Eppendorf tubes and mixed using a vortex for 30 seconds and placed back on ice. 60 microliters of the supernatant were then added in triplicate to a 96 well plate, and then a further 180 µl of buffered substrate solution (BBS) into each well. The BBS was made up when required using substrate buffer (0.13 M

Tris-HCL (1000 ml), 2 ml Triton x-100 (0.2% v/v), pH adjusted to 8.5 using 1M HCL at 20°C and adding 1.7 mM NADH and 250 µM NADPH. Once the supernatant-buffer solution reached room temperature the reaction was initiated via the addition of 60 µl of INT (8 mM,) and the well plate immediately placed in the spectrophotometer. The absorbance of the reaction was measured at 490 nm every 30 s for 10 min to determine the amount of formazan produced by the reaction.

### 5.3.5. Cellular Energy Allocation – Calculations

The energy fractions of the carbohydrate, lipids and protein from each sample were combined to give total energy available  $Ea$ /mg of tissue. ETS values were used to estimate INT-formazan production, by estimating the reaction rate. This was then converted to oxygen consumption by using the equation:

$$ETS \text{ (Moles } O_2 \text{ min}^{-1}\text{)} = (\Delta y_{490} * (Vr\epsilon) * (Vos/Vws)) * 0.5$$

Where  $\Delta y_{490}$  is the change in the absorption readings at 450nm,  $Vr$  is the amount of supernatant-buffer mixture in each well of the 96 well plate,  $\epsilon$  is the extinction coefficient for formazan at  $159000 \text{ M}^{-1}/\text{cm}^{-1}$  (De Coen and Janssen, 1997),  $Vos$  is the total amount of sample and homogenate,  $Vws$  is the total amount of supernatant transferred into each well of the 96 well plate, and 0.5 is to convert formazan to oxygen, 2 M of INT- Formazan = consumption of 1 M of oxygen (Cammen et al., 1990), the oxygen consumed is the converted into its energetic equivalent using the oxygenthalpic equivalent  $484 \text{ kJ mM}^{-1}O_2$ , comprised of the average specific values for carbohydrate, lipid and protein (Gnaiger, 1983).

CEA was calculated by the ratio of total energy status available, expressed as  $Ea$ , and energy consumed expressed as  $Ec$  (De Coen and Janssen, 1997).

$$Ea = \sum \text{Energy fractions (lipids, carbohydrates, proteins) } mJ \text{ mg}^{-1} \text{ (wet weight}^{-1}\text{)}$$

$$Ec = ETS \text{ activity } mJ \text{ mg}^{-1} \text{ min}^{-1}$$

$$CEA = Ea/Ec \text{ mJ mg}^{-1}$$

#### 5.4 Statistical Analysis

For the purpose of the statistical analysis, the sampling locations within sites, beds A and B, were treated as replicates and therefore the cockles selected from each bed were combined to provide a total number of 16 individuals per site for each season. This was to reduce the error associated with low sample sizes due to the large variation in values. All energy fraction values (*CEA*, *Ea*, *Ec*, carbohydrate, lipid and protein) were tested for normality by visual inspection of a Q-Q plot and residual plots in R statistical software along with a Shapiro-Wilks test of normality. A Levenes test was used for assessing the homogeneity of variance of the data. A Two-way Analysis of Variance (ANOVA) was conducted on each of the energy fractions (dependant variables): *CEA*, *Ea*, *Ec*, carbohydrate, lipid and protein. The ANOVA tested the main effects and the interaction of the independent variables which consisted of site (2 levels = Dee estuary and Traeth Melynog) and season (4 levels = autumn, winter, spring and summer) on their influence on each of the dependent variable. A TukeyHSD post hoc analysis was conducted when the significance past the  $p < 0.05$  criteria to determine the differences between the pair-wise comparisons of the independent variables. The null hypothesis for the two-way ANOVA is that there is no difference in the biochemical composition of cockles between the two sampling sites, across the seasons. The ANOVA model and TukeyHSD test are described in Chapter 3.

Pearson's correlation coefficients were calculated on the shell length of all individual cockles against each of the values of each of the energy fractions (*CEA*, *Ea*, *Ec*, carbohydrate, lipid and protein) to test the relationship between the two variables.

The pearson's correlation coefficient is expressed as:

$$r_{x,y} = \frac{cov(x, y)}{\sigma_x \sigma_y}$$

Where:  $x, y$  = pair of random variables

$cov$  = covariance

$\sigma_x$  = standard deviation of  $X$

$\sigma_y$  = standard deviation of  $Y$



The same sediment temperature data from Chapter 4 was used to make comparisons between the environmental conditions at each site and the levels of the biochemical components over the duration of the sampling period. All the data were analysed using RStudio (version 1.1.419).

## 5.5 Results

### 5.5.1 CEA analysis

The results of two-way ANOVA showed that the main effect of site on the energy status (mean,  $\pm$  standard deviation) to cockles was significant ( $p < 0.001$ ) (Table 2). The mean *CEA* value was found to be greater at Traeth Melynog ( $23.24 \pm 1.8 \text{ mJ mg}^{-1}$ ) than at the Dee estuary ( $16.05 \pm 1.7 \text{ mJ mg}^{-1}$ ) (Fig. 2a) (Table 8). Season was also found to have a significant effect on the *CEA* value ( $p < 0.001$ ) (Table 2) and the TukeyHSD test revealed the summer to be different to all other seasons (summer:autumn,  $p = 0.003$ ; summer:winter,  $p = 0.002$  and summer:spring,  $p < 0.001$ ) (Fig. 2d). No other pair-wise comparisons of seasons returned a significant result indicating that in the summer, cockles in North Wales had the highest energetic status. In summer the highest mean value was observed at  $23.25 (\pm 3.89) \text{ mJ mg}^{-1}$ . Autumn had the lowest *CEA* value of all seasons at  $16.85 (\pm 3.71) \text{ mJ mg}^{-1}$  (Table 8).

The interaction between sites and season on the *CEA* value was also found to be significant ( $p < 0.001$ ) (Table 2). The TukeyHSD test showed that for seasonal comparisons within the Dee estuary, differences were found between: autumn:winter ( $p < 0.001$ ), winter:spring ( $p < 0.001$ ), and winter:summer ( $p = 0.002$ ) (Table 2) (Fig. 2d). Winter was found to have lowest *CEA* value of  $11.13 (\pm 2.04) \text{ mJ mg}^{-1}$  at this site (Table 8). Within Traeth Melynog, significant differences of  $p < 0.001$  were found between: autumn:winter; autumn:summer; winter:spring and winter:summer (Fig. 2d). Spring had the lowest *CEA* value of  $15.45 (\pm 3.6) \text{ mJ mg}^{-1}$  (Table 8). For seasonal comparisons across sites, there was significant differences between the winter, spring and summer seasons, all at  $p < 0.001$ . During the winter, cockles from Traeth Melynog had almost three times more energy available to them compared to cockles from the Dee estuary and almost twice as much during the summer (Fig. 2d).

**Table 2:** ANOVA summary of the main effects of site and season, and their interaction on the Cellular Energetic Allocation (*CEA*) in cockles from the Dee estuary and Traeth Melynog. Significant differences ( $p < 0.05$ ) in bold.

Variable comparisons	df	Sum of Squares	Mean of Squares	F value	P value
Site	1	896	896.1	18.252	<b>&lt;0.001</b>
Season	3	1137	379	7.719	<b>&lt;0.001</b>
Site:Season	3	6121	2040.5	41.558	<b>&lt;0.001</b>
Residuals	120	5892	49.1		

### 5.5.2 *Ea* analysis

The results of the two-way ANOVA showed that for the main effect of site on the energy fractions (*Ea*) had a significant effect ( $p < 0.001$ ) (Table 3). The mean *Ea* value in Traeth Melynog cockles of  $1447.87 (\pm 107.2)$  mJ mg<sup>-1</sup> was found to be 30% greater higher than the mean value observed from Dee estuary cockles ( $1087.01 \pm 77.1$  mJ mg<sup>-1</sup>) (Fig. 2b) (Table. 8). For the main effect of season on the *Ea*, there was also a significant result ( $p < 0.001$ ) (Table 3). The TukeyHSD test revealed that the *Ea* values across seasons followed the same pattern which was observed from the *CEA* analysis – namely, that summer was significantly different to all other seasonal comparisons (autumn:summer, winter:summer and spring:summer, all  $p < 0.001$ ). Summer also had the highest mean value observed at  $1487.9 (\pm 216.3)$  mJ mg<sup>-1</sup> (Fig. 2e). The lowest *Ea* value was observed in autumn ( $1173.6 \pm 271.8$  mJ mg<sup>-1</sup>) (Table 8).

The interaction between site and season was also found to have a significant effect on the *Ea* results ( $p < 0.001$ ) (Table 3). The TukeyHSD test showed that for seasonal comparisons within the Dee estuary, winter was found to be different to all other seasons: autumn:winter ( $p < 0.001$ ); winter:spring ( $p < 0.001$ ) and winter:summer ( $p < 0.001$ ). The lowest mean *Ea* value from the Dee estuary was observed in winter ( $681.26 \pm 136.7$  mJ mg<sup>-1</sup>). One other seasonal comparison also returned a significant difference and that was between the autumn and spring ( $p = 0.037$ ). Within Traeth Melynog, significant differences between seasons were found between: autumn:winter; autumn:summer; winter:spring and spring:summer, at  $p < 0.001$  (Fig. 2e). The highest mean *Ea* value observed in summer at Traeth Melynog was  $1843.41 (\pm 204.4)$  mJ mg<sup>-1</sup>. For seasonal comparisons across sites, there was significant differences between the winter, spring and summer seasons, all at  $p < 0.001$ , once again matching the outcome from the *CEA* analysis (Fig. 2e). Interestingly, where the Dee estuary had its highest mean *Ea* value of

1415.56 ( $\pm 255.5$ ) mJ mg<sup>-1</sup>, Traeth Melynog returned its lowest in spring at 943.9 ( $\pm 110.5$ ) mJ mg<sup>-1</sup>, suggesting that conditions at the Dee estuary are more favourable during this time of year (Fig. 2d).

**Table 3:** ANOVA summary of the main effects of site and season, and their interaction on the sum of the energy fractions (*Ea*) in cockles from the Dee estuary and Traeth Melynog. Significant differences ( $p < 0.05$ ) in bold.

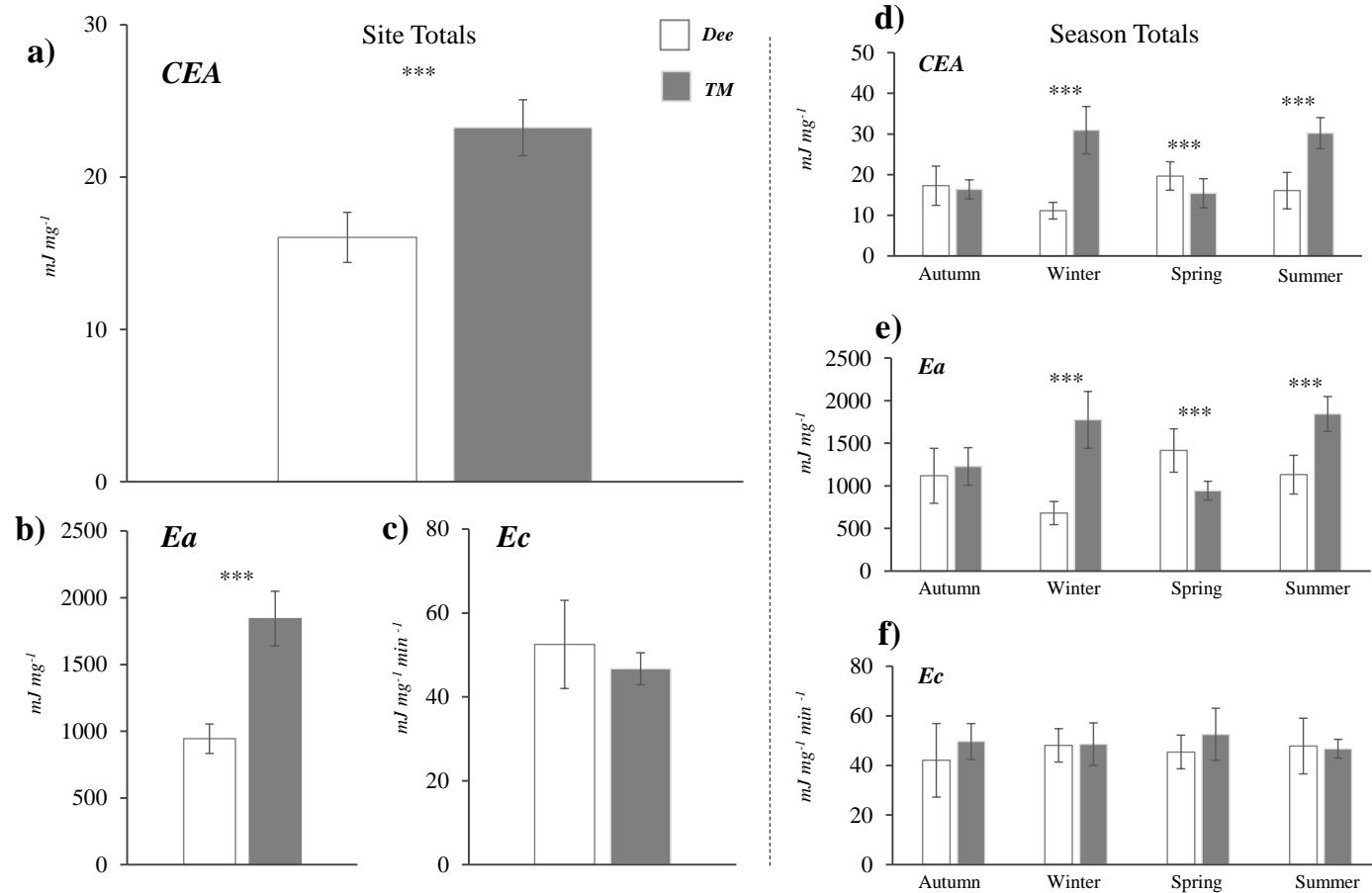
Variable comparisons	df	Sum of Squares	Mean of Squares	F value	P value
Site	1	4167043	4167043	60.40	<b>&lt;0.001</b>
Season	3	2131704	710568	10.30	<b>&lt;0.001</b>
Site:Season	3	11338196	3779399	54.78	<b>&lt;0.001</b>
Residuals	120	8278943	68991		

### 5.5.3 *Ec* (Electron Transport System) analysis

The results from the two-way ANOVA did not return any significant effect of either of the main effects (site or season) or the interaction between the two (Table 4). The mean *Ec* values were observed to be marginally higher in cockles from Traeth Melynog and displayed less variation ( $49.35 \pm 3.6$  mJ mg<sup>-1</sup> min<sup>-1</sup>) compared to the *Ec* values in cockles from the Dee estuary ( $45.85 \pm 4.4$  mJ mg min<sup>-1</sup>) (Fig. 2c). The highest observed mean *Ec* value was in summer at Traeth Melynog was 52.49 ( $\pm 10.5$  mJ) mg min<sup>-1</sup> and the lowest was found in the winter at the Dee estuary at 45.42 ( $\pm 6.8$ ) mJ mg min<sup>-1</sup> (Fig. 2f).

**Table 4:** ANOVA summary of the main effects of site and season, and their interaction on the *ETS* activity (*Ec*) in cockles from the Dee estuary and Traeth Melynog.

Variable comparisons	df	Sum of Squares	Mean of Squares	F value	P value
Site	1	392	392.2	3.711	0.056
Season	3	177	59.0	0.558	0.644
Site:Season	3	478	159.4	1.508	0.216
Residuals	120	12683	105.7		



**Figure 2.** a) Total Cellular Energetic Allocation (*CEA*) value for each site, calculated by a ratio of energy available: energy consumed (*Ea/Ec*); b) Energy available (*Ea*) for each site, derived from the total  $\text{mJ mg}^{-1}$  tissue of the energy fractions: carbohydrates, lipids and proteins; c) Energy consumed (*Ec*) for each site, expressed as  $\text{mJ mg}^{-1} \text{min}^{-1}$  and derived from electron transport system. Graphs d, e & f showing the total values per site for each of the sampling season. Values taken from *Cerastoderma edule* between autumn 2014 and summer 2015 from the Dee Estuary (white) and Traeth Melynog (grey). Error bars =  $\pm$  1SD. Significant differences between sites shown: \* =  $p < 0.05$ , \*\* =  $p < 0.01$  and \*\*\* =  $p < 0.001$ .

#### 5.5.4 Carbohydrate analysis

The main effect of site on the energy derived from carbohydrate content was shown through the two-way ANOVA to be significantly different between the Dee estuary and Traeth Melynog ( $p=0.024$ ) (Table 5). Mean values were higher in cockles from the Dee estuary at  $584.12 (\pm 228.2) \text{ mJ mg}^{-1}$ , than cockles from Traeth Melynog at  $501.36 (\pm 197.3) \text{ mJ mg}^{-1}$  (Fig. 3a). The main effect of season also had a significant effect on the carbohydrate content ( $P<0.001$ ) and the TukeyHSD test revealed that winter was significantly different to all other seasonal comparisons (autumn:winter,  $p<0.001$ ; winter:spring,  $p=0.004$  and winter: summer,  $p<0.001$ ) (Fig. 3a). Overall, the carbohydrate content in the winter was  $299.3 (\pm 147.2) \text{ mJ mg}^{-1}$ , which was considerably less than any of the other seasons. Autumn had the highest content of  $643.7 (\pm 246.9) \text{ mJ mg}^{-1}$ .

The interaction between the main effects site and season, was also found to have a significant influence on the carbohydrate content ( $p<0.001$ ) (Table 5) (Fig. 3b). The TukeyHSD test showed that within the Dee estuary, comparison's between seasons followed the same pattern that was observed for the main effect of season, whereby the carbohydrate content in the winter was significantly different at  $p<0.001$  to all other seasons (Fig. 3b). Within Traeth Melynog, the TukeyHSD test showed significant differences in the carbohydrate content between the season comparisons of: autumn:spring ( $p<0.001$ ); winter and summer ( $p=0.007$ ) and spring:summer ( $p<0.001$ ). For the between sites seasonal comparisons, only the spring was significantly different between the Dee estuary and Traeth Melynog ( $p<0.001$ ), and it was this sampling period where the lowest and highest mean carbohydrate content were observed (Dee:  $801.8 \pm 215.8 \text{ mJ mg}^{-1}$ ; TM:  $252.56 \pm 144 \text{ mJ mg}^{-1}$ ) (Fig. 3b).

**Table 5:** ANOVA summary of the main effects of site and season, and their interaction on the carbohydrate content in cockles from the Dee estuary and Traeth Melynog. Significant differences ( $p < 0.05$ ) in bold.

Variable comparisons	df	Sum of Squares	Mean of Squares	F value	P value
Site	1	219136	219163	5.22	<b>0.024</b>
Season	3	1910142	636714	15.16	<b>&lt;0.001</b>
Site:Season	3	2456737	818912	19.50	<b>&lt;0.001</b>
Residuals	120	5038381	41987		

### 5.5.5 Lipid analysis

Energy derived from lipid content from the cockle samples displayed the greatest variability between the Dee estuary and Traeth Melynog, compared to the other biochemical constituents (Fig. 3a). The two-way ANOVA confirmed this observation and showed that the main effect of site on the lipid content was significant ( $p < 0.001$ ) (Table 6). Mean values from Traeth Melynog reached  $531.72 (\pm 330.1) \text{ mJ mg}^{-1}$ , which was over four times greater than observed for the Dee estuary at  $120.47 (\pm 89.5) \text{ mJ mg}^{-1}$  (Fig. 3a) (Table 8). The main effect of season on lipid content was also shown to be significant ( $p < 0.001$ ) and the TukeyHSD test revealed that this was driven by the season comparisons of: autumn:winter; autumn:summer; winter:spring and spring:summer, all at  $p < 0.001$  (Fig. 3c). Winter was found to have the highest mean lipid value of  $479.63 (\pm 138.3) \text{ mJ mg}^{-1}$  and autumn had the lowest at  $129.71 (\pm 51.2) \text{ mJ mg}^{-1}$ .

The interaction of site and season was also shown to have a significant effect on the lipid content ( $p < 0.001$ ), and this result was driven by seasonal comparisons between sites and within Traeth Melynog only. Within the Dee estuary there was no observed differences between the seasons. Within Traeth Melynog, the TukeyHSD test showed that the summer and was significantly different to all other seasons (autumn:summer,  $p < 0.001$ ; winter:summer,  $p = 0.009$  and spring:summer,  $p < 0.001$ ) (Fig. 3c). Winter was also significantly different to the autumn and spring, both a  $p < 0.001$ . (Fig. 3c). Between-site differences were found in the winter ( $p < 0.001$ ) and summer ( $p < 0.001$ ). The lowest mean value for lipid content was observed in the Dee estuary at  $53.95 (\pm 40) \text{ mJ mg}^{-1}$  during the winter, whereas Traeth Melynog had the highest at  $905.51 (\pm 236.56) \text{ mJ mg}^{-1}$  (Fig. 3c).

**Table 6:** ANOVA summary of the main effects of site and season, and their interaction on the carbohydrate content in cockles from the Dee estuary and Traeth Melynog. Significant differences ( $p < 0.05$ ) in bold.

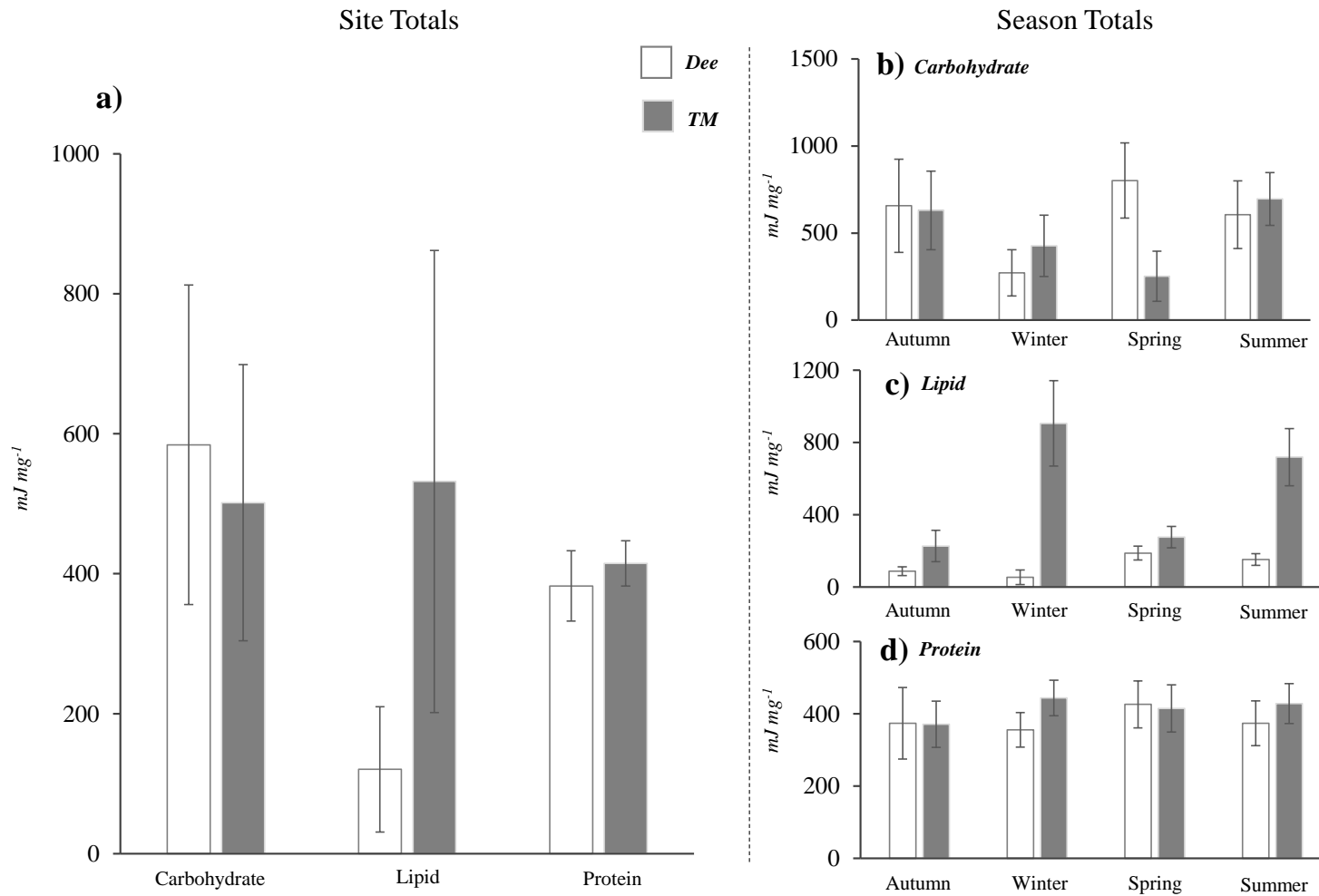
Variable comparisons	df	Sum of Squares	Mean of Squares	F value	P value
Site	1	5412190	5412190	260.39	<b>&lt;0.001</b>
Season	3	2335848	778616	37.46	<b>&lt;0.001</b>
Site:Season	3	3169681	1056560	50.83	<b>&lt;0.001</b>
Residuals	120	2494173	20785		

### 5.5.6 Protein analysis

Out of all of the biochemical assays, energy derived from protein had the least variation across both sites and seasons (Fig. 3c). The two-way ANOVA showed that the main effect of site on the protein content was significant ( $p=0.012$ ) but for the main effect of season, it was not (Fig. 3a) (Table 7). Overall, cockles from Traeth Melynog had more protein available to them mean at  $414.79 (\pm 32.3) \text{ mJ mg}^{-1}$  at Traeth Melynog, compared to  $382.43 (\pm 50.3) \text{ mJ mg}^{-1}$  at the Dee estuary (Table 8). The interaction of site and season on protein content was also significant ( $p=0.019$ ), but this was not due to within site pair-wise comparisons, as there was not any significant differences found between seasons. Only the winter, between the Dee estuary and Traeth Melynog, returned a significant difference of  $p=0.016$  (Fig. 3d) and it was also when the highest and lowest mean seasonal values were observed. The Dee estuary had the lowest at  $355.68 (\pm 48) \text{ mJ mg}^{-1}$ , with Traeth Melynog the highest at  $443.92 (\pm 48.9) \text{ mJ mg}^{-1}$ .

**Table 7:** ANOVA summary of the main effects of site and season, and their interaction on the carbohydrate content in cockles from the Dee estuary and Traeth Melynog. Significant differences ( $p<0.05$ ) in bold.

Variable comparisons	df	Sum of Squares	Mean of Squares	F value	P value
Site	1	33515	33515	6.475	<b>0.012</b>
Season	3	37684	12561	2.427	0.069
Site:Season	3	53749	17916	3.461	<b>0.019</b>
Residuals	120	621126	5176		



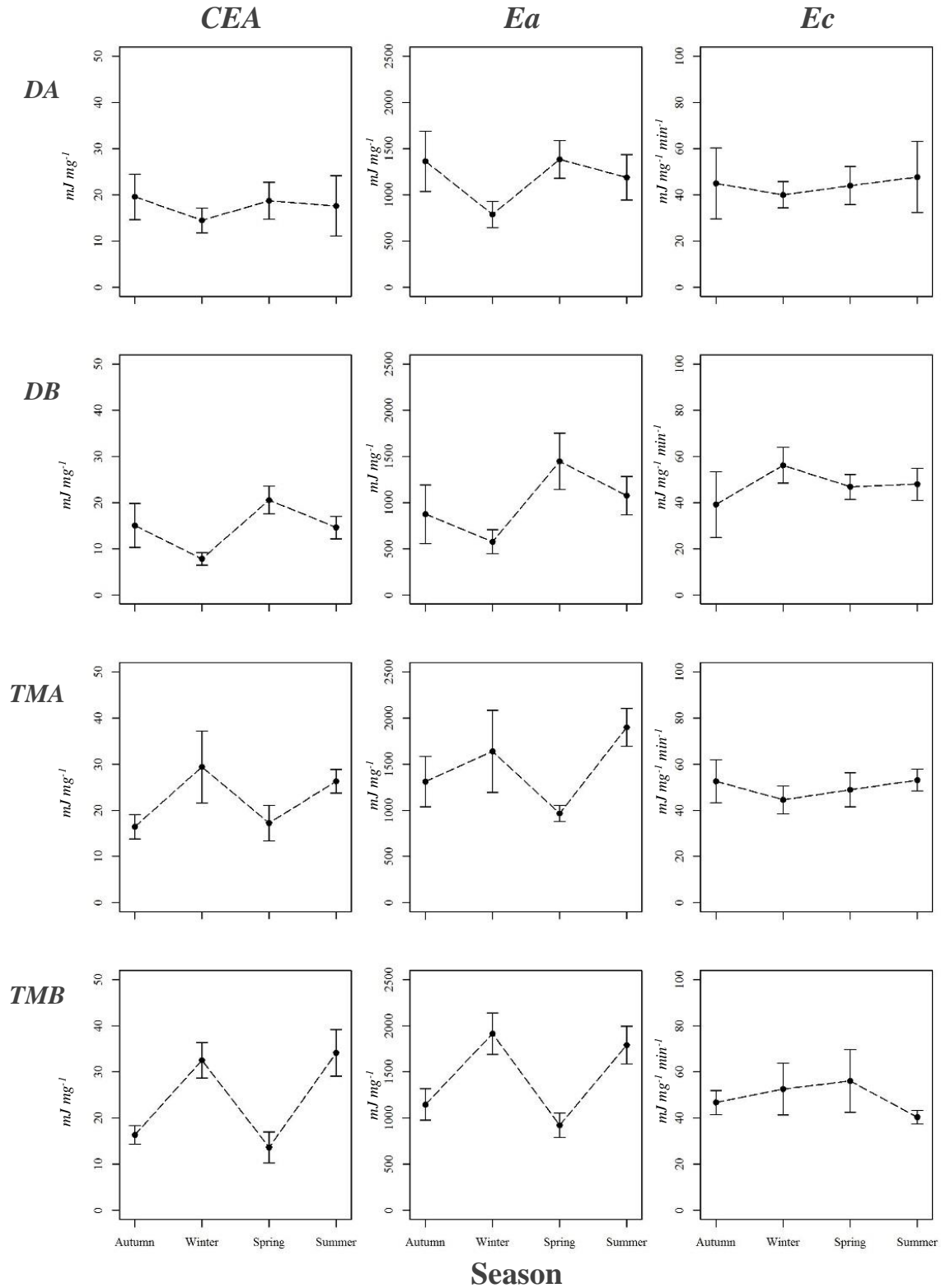
**Figure 3.** a) Total energy available from cellular carbohydrate, lipid and protein content for each site in mJ mg derived from the energy equivalents of: 17500 mJ mg<sup>-1</sup>, carbohydrates; 39500 mJ mg<sup>-1</sup>, lipids and 24000 mJ mg<sup>-1</sup>, proteins. Graphs b, c & d show the total values per site for each of the sampling seasons. Values taken from *Cerastoderma edule* between autumn 2014 and summer 2015 from the Dee Estuary (white) and Traeth Melynog (grey). Error bars =  $\pm$  1SD. Significant differences between sites shown: \* =  $p < 0.05$ , \*\* =  $p < 0.01$  and \*\*\* =  $p < 0.001$ .



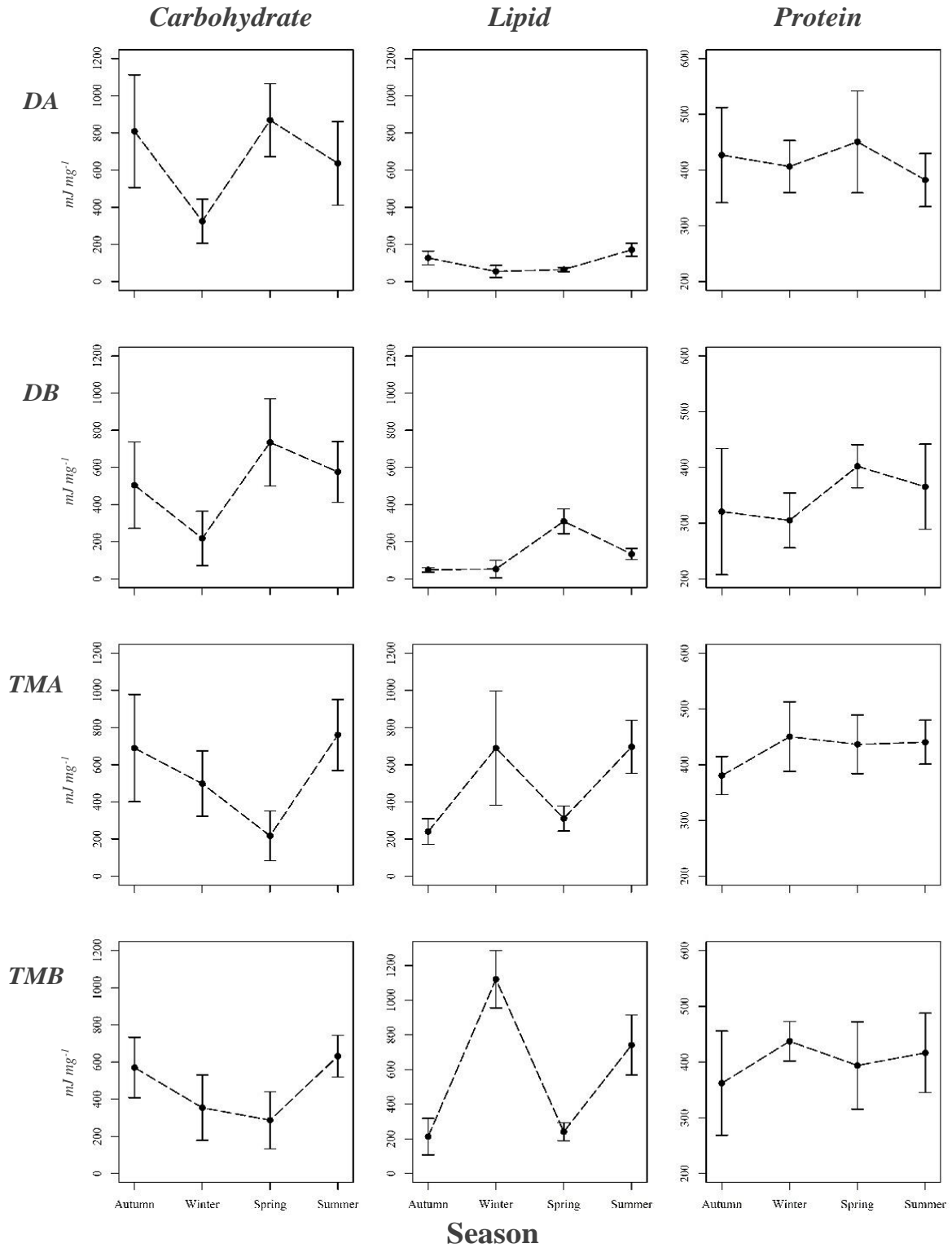
Chapter 5

**Table 8.** Mean energy reserve fractions ( $E_a$ ;  $n = 8$ ), the energy consumption values ( $E_c$ ;  $n = 8$ ) and the Cellular Energetic Allocation values ( $CEA$ ;  $n=8$ ), for each bed within the Dee estuary and Traeth Melynog across the sampling seasons.

<i>Site (bed)</i>	<i>Season</i>	<i>E<sub>a</sub> (mJ mg<sup>-1</sup>)</i>								<i>E<sub>c</sub> (mJ mg<sup>-1</sup> min<sup>-1</sup>)</i>	<i>SD</i>	<i>CEA (mJ mg<sup>-1</sup>)</i>	<i>SD</i>
		<i>Carbohydrates</i>	<i>SD</i>	<i>Lipids</i>	<i>SD</i>	<i>Proteins</i>	<i>SD</i>	<i>Total</i>	<i>SD</i>				
<b>Dee (DA)</b>	Autumn	809.42	303.49	127.28	36.65	426.93	85.37	1363.63	326.65	44.96	15.3	19.56	4.9
	Winter	325.04	119.19	54.55	32.46	406.42	46.67	786.02	143.44	40.04	5.73	14.45	2.7
	Spring	868.58	197.26	64.42	10.63	450.64	91.46	1383.64	205.13	44.02	8.24	18.75	4.
	Summer	636.08	225.04	171.09	35.62	382.25	47.66	1189.42	247.11	47.73	15.42	17.63	6.52
<b>(DB)</b>	Autumn	504.70	232.73	48.62	11.87	320.75	113.09	874.06	318.90	39.18	14.31	15.04	4.76
	Winter	218.21	146.25	53.35	47.53	304.94	49.25	576.50	129.88	56.17	7.75	7.82	1.38
	Spring	735.02	234.39	310.40	66.53	402.07	38.70	1447.48	305.92	46.82	5.35	20.56	3.01
	Summer	575.90	164.23	134.03	29.42	365.42	76.33	1075.35	209.08	47.89	7.01	14.58	2.44
<b>Dee average</b>		<b>584.12</b>	<b>202.82</b>	<b>120.47</b>	<b>33.84</b>	<b>382.43</b>	<b>68.57</b>	<b>1087.01</b>	<b>235.76</b>	<b>45.85</b>	<b>9.89</b>	<b>16.05</b>	<b>3.71</b>
<b>TM (TMA)</b>	Autumn	689.76	288.83	240.09	69.08	380.58	34.32	1310.43	270.77	52.57	9.29	16.46	2.66
	Winter	498.37	176.00	690.20	307.76	450.48	62.40	1639.04	443.79	44.55	6.03	29.38	7.78
	Spring	217.74	134.14	310.94	67.69	436.64	52.47	965.33	88.16	48.9	7.37	17.23	3.85
	Summer	760.66	190.29	695.96	142.67	440.56	39.48	1897.18	204.12	53.09	4.7	26.29	2.55
<b>(TMB)</b>	Autumn	570.80	162.58	213.24	105.18	362.19	93.56	1146.23	170.81	46.72	5.15	16.36	2.02
	Winter	354.49	176.27	1120.81	165.36	437.36	35.44	1912.67	224.33	52.58	11.20	32.51	3.83
	Spring	287.37	153.79	241.14	51.97	393.96	78.29	922.46	132.91	56.08	13.63	13.62	3.39
	Summer	631.69	112.46	741.41	173.42	416.55	71.22	1789.65	204.70	40.32	2.9	34.12	5.04
<b>TM average</b>		<b>501.36</b>	<b>174.30</b>	<b>531.72</b>	<b>135.39</b>	<b>414.79</b>	<b>58.40</b>	<b>1447.87</b>	<b>217.45</b>	<b>49.35</b>	<b>7.53</b>	<b>23.25</b>	<b>3.89</b>



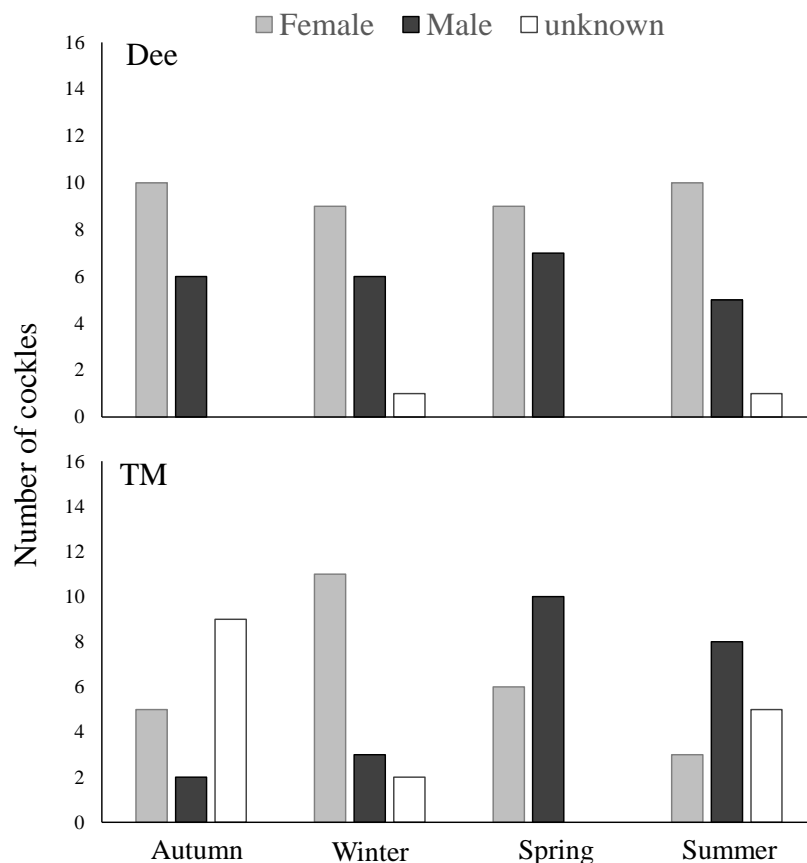
**Figure 4.** Total Cellular Energetic Allocation (CEA) value, calculated by a ratio of energy available: energy consumed ( $Ea/Ec$ ) in *Cerastoderma edule*; Energy available ( $Ea$ ), derived from the total  $mJ\ mg$  tissue of the energy fractions: carbohydrates, lipids and proteins; Energy consumed ( $Ec$ ), expressed as  $mJ\ mg$  tissue per minute and derived from electron transport system for each of the cockle beds (rows) sampled between autumn 2014 and summer 2015.  $n = 8$ ,  $\bullet$  = mean value, error bars =  $\pm 1$ SD.



**Figure 5.** Energy available from cellular carbohydrate, lipid and protein content (columns) in half body sections of *Cerastoderma edule* ( $n=8$ ) across each bed (rows), between autumn 2014 and summer 2015.  $\text{mJ mg}^{-1}$  derived from the energy equivalents of: 17500  $\text{mJ mg}^{-1}$ , carbohydrates; 39500  $\text{mJ mg}^{-1}$ , lipids and 24000  $\text{mJ mg}^{-1}$ , proteins.  $n=8$ ,  $\bullet$  = mean value, error bars =  $\pm 1\text{SD}$ .

### 5.5.7 Sex Ratios between sites and seasons

Data on the sex of the individuals was taken from the dataset used in Chapter 4 which quantified the sex of each individual cockle via the histological analysis. Out of a total of 128 cockles selected for this study, 68 were female, 42 were male and 18 were unidentified (Fig.6; Table 10). The spring was the only time of year when all cockles sampled across both sites were able to be sexed, as this coincided with the peak reproductive period for the cockles, thus aiding identification and maturity. A total of 18 cockles were not able to be sexed due to difficulty in identification in the histology samples (Chapter 4). This was either due to: a) being in the dormant stages of maturity, and therefore having little gonadal development (commonly observed in the winter sampling); b) already having spawned and therefore assumed spent; or c) not having had gonad tissue sectioned in the histology process.



**Figure 6.** Total of number cockles f of female, male and those which were unidentified from each site (Dee: top, TM: bottom) for the different seasons.

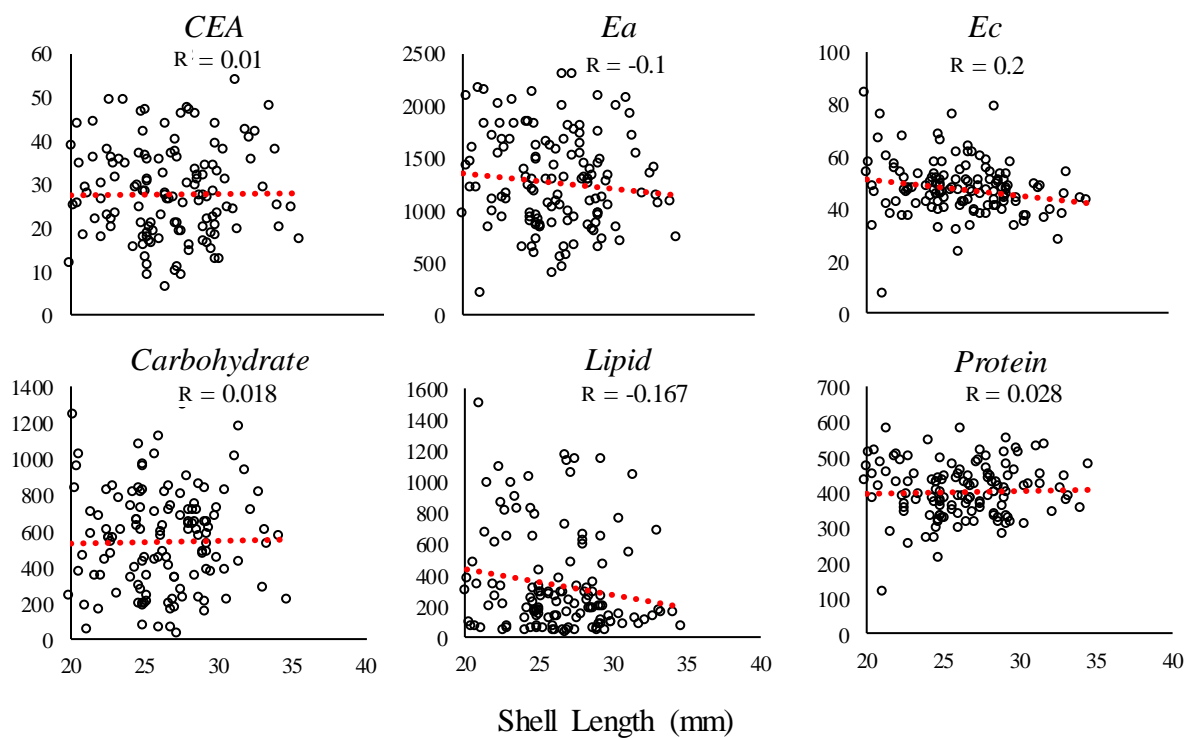
Chapter 5

**Table 10.** Mean energy reserve fractions ( $Ea$ ;  $n = 16$ ), the energy consumption values ( $Ec$ ;  $n = 16$ ) and the Cellular Energetic Allocation values ( $CEA$ ;  $n = 16$ ) from the Dee estuary and Treath Melynog, for the different sexes identified from *Cerastoderma edule* through histological analysis in Chapter 4.

Site	Season	Sex	$Ea$ ( $mJ\ mg^{-1}$ )							$Ec$ ( $mJ\ mg^{-1}\ min^{-1}$ )	SD	CEA ( $mJ\ mg^{-1}$ )	SD	
			Carbohydrates	SD	Lipids	SD	Proteins	SD	Total					SD
Dee	Autumn	Female	668.11	272.82	88.74	40.80	373.06	92.56	1129.91	340.31	43.48	13.43	27.72	10.78
		Male	638.64	380.04	86.63	63.47	375.13	147.31	1100.40	523.81	39.71	17.50	28.27	7.01
		unknown												
	Winter	Female	272.71	167.62	49.98	32.68	387.36	68.66	710.06	207.99	42.84	9.44	17.58	6.68
		Male	283.72	111.70	62.52	52.58	315.43	54.86	661.67	111.17	54.66	9.00	12.53	3.61
		unknown	189.26	0	38.30	0	312.09	NA	539.65	NA	56.13		9.61	
	Spring	Female	872.62	259.17	176.26	148.54	438.45	58.32	1487.34	294.26	48.17	7.15	31.42	7.40
		Male	710.75	160.46	201.73	128.29	410.80	92.18	1323.28	191.82	41.89	5.62	31.96	5.80
		unknown												
Summer	Female	652.16	201.44	161.78	38.45	380.51	45.70	1194.46	220.86	48.45	14.78	27.04	10.69	
	Male	490.45	150.88	142.78	31.34	327.22	3.44	960.44	160.49	46.50	2.76	20.70	3.58	
	unknown	670.22		127.83		456.55		1254.59		33.31		37.67		
TM	Autumn	Female	585.56	228.01	209.71	68.14	395.95	110.58	1191.22	262.99	50.19	11.08	24.05	4.69
		Male	749.32	287.93	182.77	18.85	366.31	5.34	1298.39	274.42	50.34	1.93	25.91	6.45
		unknown	628.67	265.54	245.84	110.97	358.87	35.85	1233.38	254.85	49.18	7.74	25.37	5.58
	Winter	Female	460.64	167.57	895.59	322.49	459.07	35.42	1815.30	278.31	48.01	10.60	38.66	6.54
		Male	361.22	296.39	856.57	504.65	372.79	47.88	1590.58	731.48	49.42	10.92	31.13	9.20
		unknown	336.07	136.70	1033.44	75.96	467.26	28.57	1836.78	241.23	50.33	4.18	36.42	1.77
	Spring	Female	316.90	197.27	278.68	97.45	409.60	79.36	1005.18	128.30	45.59	5.64	22.46	4.56
		Male	213.95	92.24	274.46	50.47	418.72	64.69	907.12	86.31	56.63	11.88	16.61	3.57
		unknown												
	Summer	Female	698.31	189.05	766.43	134.89	411.11	24.66	1875.85	217.14	49.04	7.54	39.12	8.11
		Male	614.62	27.67	650.88	262.76	408.20	35.87	1673.69	261.05	39.75	0.93	42.20	7.34
		unknown	741.70	118.25	682.97	97.51	468.67	93.01	1893.34	87.75	47.15	9.51	41.07	7.68

### 5.5.8 Biochemical components and shell length correlations

A series of correlations were run to investigate the linear relationship between shell lengths of *C. edule* and the biochemical components. The range of individual shell lengths that were measured varied between 20.04 mm and 34.7 mm. Energy available ( $E_a$ ), energy consumed ( $E_c$ ) and lipids all displayed a negative relationship with shell length (Fig. 7), however only for  $E_c$  was this found to be significant ( $p=0.02$ ) (Table. 11), indicating that the larger the size of the cockle, the lower its metabolic activity. No relationships were observed between  $CEA$ , carbohydrate or protein contents.



**Figure 7.** Relationship between shell length and the different biochemical components derived from all samples of *Cerastoderma edule*. Linear trendline in red

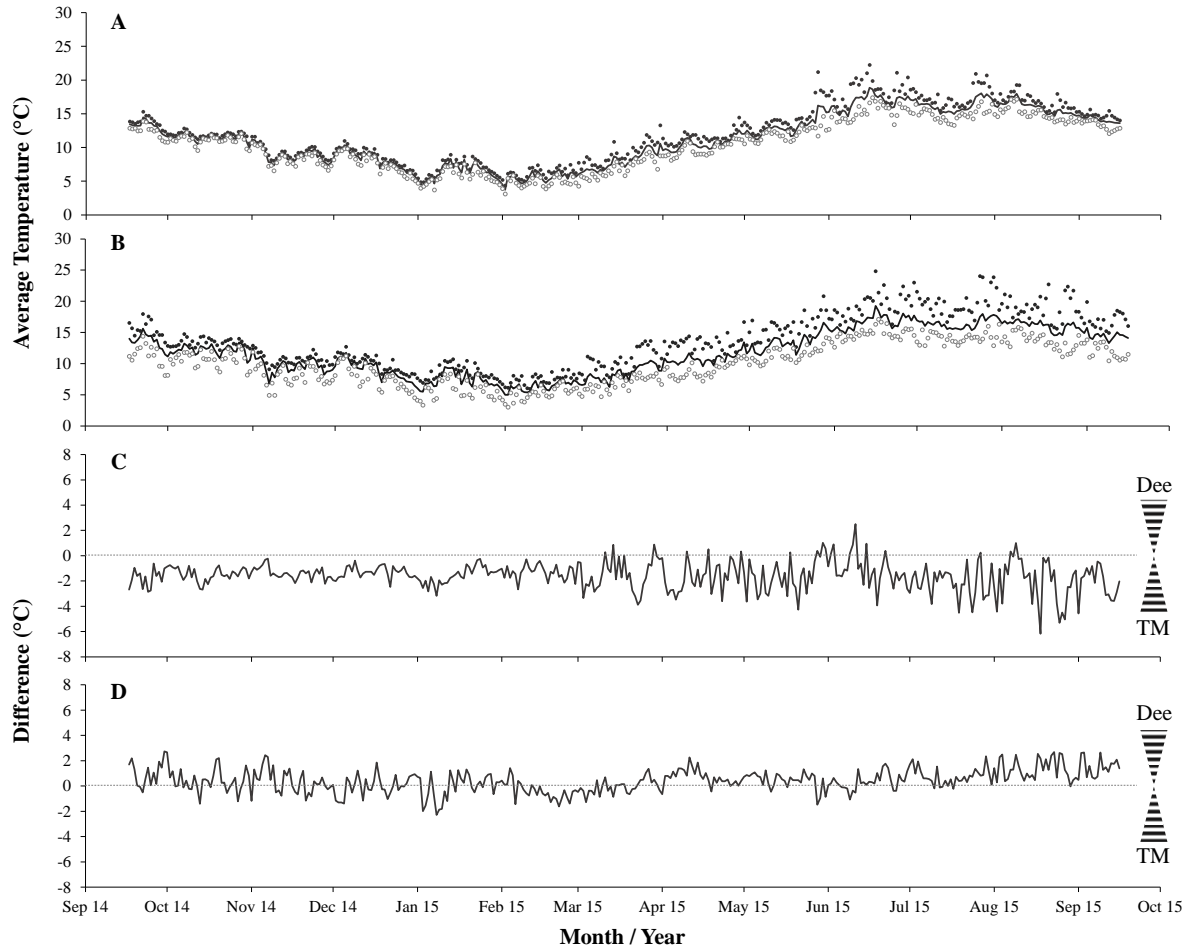
**Table 11.** Results from the Pearson correlation of the shell length of *Cerastoderma edule* against each of the biochemical components. Shell length of individual. Significant values in bold

Biochemical component	R	P value
<i>CEA</i>	0.01	0.91
$E_a$	-0.10	0.24
$E_c$	-0.20	<b>0.02</b>
Carbohydrates	0.018	0.84
Lipids	-0.167	0.06
Proteins	0.028	0.76

### 5.5.9 Temperature data

## Chapter 5

During the sampling period between 2014 & 2015, the sediment temperature at the Dee Estuary ranged from 3.14°C in February 2015 to 22.27°C in June 2015 with an overall mean of 11.24°C. For Traeth Melynog the mean temperature recorded was 11.74°C and it ranged from 3.03°C February 2015 to 24.8°C in June 2015. (see Chapter. 4 for statistical analysis on the sediment temperature data) (Fig. 8).



**Figure 8.** Average daily temperature of the sediment at 5cm depth during the sampling period for both the Dee Estuary (A) and Traeth Melynog (B) (solid line), with the maximum (●) and minimum (○) values shown for each day. Differences in temperature illustrated in graphs C (maximum temperature difference) & D (minimum temperature difference). Positive values indicate that the Dee Estuary had a higher temperature than Traeth Melynog and negative values indicates Traeth Melynog had a higher temperature than the Dee Estuary.

## 5.6 Discussion

The Cellular Energy Allocation technique provides a good assessment of the impact of environmental stress on the different parameters of the energy metabolism. By integrating these parameters into a single value reflecting the net energy status of an organism (De Coen and Janssen, 1997), inferences can be made about how organisms respond to their environment. It can also support longer-term predictions at a population level (Smolders et al., 2004). Measured over the course of a year, the total *CEA* values of the two cockle fisheries suggests that *Cerastoderma edule* living at Traeth Melynog are at an advantage in terms of the energy available as opposed to those living in the Dee estuary. This advantage would benefit a range of factors including effective burrowing into the sediment to escape predation and desiccation during a falling tide; to fight off virus or mitigate against the adverse reaction from pathogenic infections (Wootton et al., 2003) or during times of low food availability and low temperatures (Honkoop and Beukema, 1997). All these factors demand higher metabolic costs and without adequate energy stores, cockles may not cope with these pressures, and succumb to reduced growth, reproduction and survival (Newell & Bayne, 1980; Calow and Silby, 1990; Kaiser et al., 2007; Bagheri et al., 2010). Generally, a lower *CEA* value would imply that an organism is not responding as well to their environment and will need to invest more energy into feeding. Whether or not the *CEA* values observed in this study are enough to provide adequate resilience against potential environmental stressors remains to be determined. The *CEA* values from both the Dee estuary and Traeth Melynog were lower than the mean *CEA* values previously observed in *C. edule* from the Dee estuary ( $34 \text{ mJ mg}^{-1}$ ) and the Burry Inlet ( $30.4 \text{ mJ mg}^{-1}$ ) between 2009 – 2011 (Elliott et al., 2012). Research by Elliott et al. (2012), sampled *C. edule* from the Dee estuary and Burry inlet and found no differences in the *CEA* values over their sampling period, which ran from April – July 2009. This period would have fallen between our own spring and summer sampling seasons, where the results from the Dee estuary dropped slightly from the spring to summer and had a mean value of less than  $18 \text{ mJ mg}^{-1}$  between seasons for this site (Fig. 2d). Even though the *CEA* values at Traeth Melynog increased from spring to summer, the mean values between the seasons were short of those found previously by Elliott et al. (2012) at almost  $23 \text{ mJ mg}^{-1}$ . It would be expected that, on account of the abundance of food available, the summer months would yield the highest *CEA* values. In this study, however, the highest mean value – from Traeth Melynog – was observed in the winter, reaching marginally above  $30 \text{ mJ mg}^{-1}$  (Fig. 2.d). In contrast, the winter season also returned the lowest mean value from the Dee estuary – of just over  $11 \text{ mJ mg}^{-1}$  (Fig. 4) (Table 10). This



disparity between studies highlights the variability in the total energy status of *C. edule* on a longer temporal scale and could indicate an increase in environmental stressors over the 5-year period between studies. By measuring *CEA* at four time points over year, this study has been able to show the short-term changes that occur within a cockle population and that the variability of *CEA* can be high (Fig. 2.c; Fig. 4).

The opposing values across the seasons between sites, e.g. where one site increased and the other decreased, shows a localised effect during the winter and summer months at Traeth Melynog. Similar seasonal differences of *CEA* values have been observed in the mussel, *Mytilus galloprovincialis* from two locations in Croatia. Erk et al. (2011) selected their sampling sites in the Krka river estuary based on differences in abiotic factors (salinity and temperature) and coastal exposure level. The authors found that, in 2007, mussels collected from the coastal location had higher mean *CEA* values in November than in June, whereas those from a sheltered location had significantly lower mean *CEA* values in November than in June (Erk et al., 2011). The research was repeated in 2008 but no differences in the *CEA* values were observed between seasons at each site. In general, when comparing sites, the coastal site showed consistently significant higher mean *CEA* values than those which were observed from the sheltered site (Erk et al., 2011).

Similarly, it is possible that the exposure level of our own sites also had some effect on energy status of *C. edule* and could therefore help explain the differences we observed between our sites (Fig. 2.a). Traeth Melynog is a relatively small intertidal bay of approximately 330 ha (Sutherland, 1982) and is situated close to the southern entrance to the Menai Strait (Fig. 1a). The mouth of the bay is wider than the distance from the mean low tide line to shore and has a tidal range of 3.5 meters between MLW to MHW (Whitton, 2013). It receives a high exchange of seawater during the flood and ebb tides and is moderately exposed to prevailing south easterly winds. The sediment at Traeth Melynog consists mainly of fine sand with a mud content of 8.7% (Whitton, 2013). At over 14,000 ha, the Dee estuary is much more extensive. It is made up of many large extensive intertidal sand banks and mud flats, divided by deep channels (Fig. 1b) (Natural England, 2010). It is also flood dominant, meaning that there is a faster flow of water into the estuary with the incoming tide than leaves during ebbing tide – which is much slower. This creates net sediment movement into the estuary, where it is a sink for both sand and silt (Bolaños and Souza 2010; Pontee et al., 2013). During all sampling periods a layer of mud 5-15 cm deep covered the sampling locations, but it was not evenly

distributed throughout the bed (personal observation). The mouth of the estuary is north west facing and experiences a mean spring tidal range of 3.4 metres (Moore et al., 2009, Pontee et al., 2013). Here, deposited sediment to outer sand banks provides some protection against incoming waves (Halcrow, 2010). Salinity concentration was also shown by Erk et al. (2011) to directly influence the *CEA* values in *M. galloprovincialis*, with the sheltered site having a higher salinity fluctuation. This emphasises that estuaries are, by nature, demanding environments on account of the high variability of conditions placed upon the organisms living in them. A reduction in *CEA* can therefore provide information about the availability and expenditure of energy of these marine organisms for maintaining the balance of life.

The total energy available (*Ea*) followed similar patterns of change across seasons (autumn to summer) to those observed in the *CEA* results from each site (Fig. 2d&e). Spring was when the Dee estuary had the highest energy available to the cockles, and this was driven by the carbohydrate content making up 58% of the total *Ea* value. It was also when the highest mean value of just over 801 mJ mg<sup>-1</sup> from this study (Fig. 3b) was observed. By contrast, the lowest *Ea* value at Traeth Melynog was also observed in the spring (252 mJ mg ww<sup>-1</sup>) and carbohydrate content made up only 27% of the total *Ea*. Carbohydrate stores are essential during the winter months when there is less food available as they are utilised and converted into lipids during gonadal development (Navarro et al., 1989; Elliott et al., 2012). As availability of food improves in the spring, the feeding rate and absorption of the biochemical components increases to support gametogenesis. Newell and Bayne (1980) observed carbohydrate content of *C. edule* sampled from the southern coast of the United Kingdom dropping in the winter months and peaking in the summer months. While this was similar to *C. edule* collected from Traeth Melynog, the pattern was not followed by cockles from the Dee estuary.

In general, it would be expected that *C. edule* begin to store the biochemical components (carbohydrate, lipid and protein) in the winter months, as these are required for gametogenesis, and that the values would peak prior to spawning as found in *C. edule* sampled from Portugal (Trindade et al., 2019). The *Ea* values in this study, however, only support these findings by Trindade et al. (2019) at Traeth Melynog. The *Ea* values observed in the winter and summer months at this site can be associated with the high proportion of lipid content (Fig. 3c), consisting of 51% (winter) and 39% (summer), possibly indicating the ripening and viability of gametes ready for spawning. The eggs from bivalve molluscs are known to contain

a high lipid content. Declines of the *Ea* value and seasonal variation of lipid content can therefore be related to the mean oocyte diameter (Liu et al., 2013) and the release of these eggs during spawning events (Gabbot, 1975; Stoeckmann and Garton, 2001; Elliott et al., 2012). If lipid content is to be indicative of the presence of eggs (Gallager and Manw, 1986; Honkoop et al., 1999), however, then there should be a notable difference in the values between male and female cockles, similar to observations on *Nucula turgida* found in Ireland (Davis and Wilson, 1983). This, however, was not the case in our study. Male cockles had equal lipid content to females over the whole sampling period. Females ( $n=68$ ) contained a mean of 320 ( $\pm 323$ )  $\text{mJ mg}^{-1}$  of lipids compared to 325 ( $\pm 325$ )  $\text{mJ mg}^{-1}$  in males ( $n=42$ ). Even during the winter at Traeth Melynog the same similarities between sexes remained (Table 10), suggesting that the high lipid values may not only be attributed to egg development but also to males containing high lipid concentration during gametogenesis. Further investigation into the male/female relationships would be beneficial to provide an insight into the reproductive cycle of cockles and its influence on the energy available. This would require ensuring that the sample sizes of both sexes were equal, which was not the case in this study. The sex of the cockle was only determined post histological screening, so it was not possible to increase sample size to account for the differences in numbers between sexes that existed across seasons and sites. The *CEA* values between males and female cockles were also similar (Table 10) which suggests other factors may be influencing our findings, such as the unbalanced sample sizes between the sexes (Fig. 7).

An explanation for why there was a large difference in lipid content (Fig. 3a) between sites has yet to be established as the values are far higher than would be normally expected. Lipid content has previously been recorded at 66 ( $\pm 18$ )  $\text{mJ mg}^{-1}$  in cockles from the Dee estuary and 81 ( $\pm 35$ )  $\text{mJ mg}^{-1}$  from the Burry Inlet in 2009 (Elliott et al., 2012). These values are less than our own from the Dee Estuary of 187 ( $\pm 39$ )  $\text{mJ mg}^{-1}$  in the spring and 153 ( $\pm 33$ )  $\text{mJ mg}^{-1}$  in the summer. They are, however, much greater than the values observed from Traeth Melynog in 2015.

The total protein content was significantly different between sites (Fig. 3a) with Traeth Melynog displaying a higher mean value. The seasonality of protein content remained relatively consistent within both sites with winter displaying the highest separation between the two (Fig. 3d; Fig. 5). It was during winter, also, when protein was shown to contribute over 50% of the total energy available in cockles from the Dee estuary. No obvious reduction in

protein content was observed at any time of year at both sites, so it is therefore difficult to link with spawning activity as seen in lipid content at Traeth Melynog. Our values for both sites are less than those previously observed from the Dee estuary of  $592 (\pm 105) \text{ mJ mg}^{-1}$  (Elliott et al., 2012) and the cause of this is unknown, however the range of values are not that dissimilar, it could be accepted that our observations, and those by Elliott et al. (2012), show the natural variation of protein in between individual cockles from North Wales. Protein contribution to the overall energy available did not affect the total *Ea* values, as the patterns observed correlated strongly with the other assays (carbohydrates and lipids).

The energy consumed (*Ec*) was marginally different between sites but did not return any difference across seasons (Fig. 2c&f). The observed seasonal similarity was unexpected as temperature is a fundamental factor affecting biological processes in marine bivalves and seasonality influences their metabolic adaption (Widdows and Bayne, 1971; Newell and Bayne, 1973; Widdows, 1973). The metabolic rate of *C. edule*, therefore, did not change in relation to the temperature fluctuations, and this points to other factors playing a role in the *Ec* values observed. Similar results were observed by Elliott et al. (2012) at the Burry Inlet and Dee estuary. They reported an increase in the energy consumed by the end of the 17-week study, however it was not significant. The mean *Ec* values throughout the study remained consistent but were highly variable (Elliott et al., 2012). The authors were able to show that energy consumed correlated negatively to cockle density but positively to both spat density and maturation stage (Elliott et al., 2012). Matuso et al. (2013) were able to show that a temperature range of 22-27°C did not alter the metabolic rate of *Mercenaria* and *Crassostrea virginica*, which is similar to our findings. However, when combining multiple stressors in this study, temperature and elevated CO<sub>2</sub> levels, the metabolic rate of *M. mercenaria* increased. Erk et al. (2012) recorded *Ec* values from the digestive gland in *Mytilus galloprovincialis* and found them 50% higher from mussels sampled in a sheltered location to those sampled from a coastal site. It was concluded that the high salinity fluctuations of the sheltered site exposed the mussels to a more demanding environment. The significance of the inverse relationship between *Ec* and shell length (Fig. 7) suggests that there is a size specific respiration rate in the cockles sampled. Size of organism has been shown to be an important factor for metabolic rate, with larger individuals having a slower one than smaller individuals (Xiao et al., 2014; Mane, 1975), and the flow of energy is greater in smaller individuals (Jadhav et al., 2012). Lower metabolic activity can be associated to larger animals as there is an increasing proportion of metabolically inactive mass as body size increases (Simčič and Brancelj, 2004). Whilst this

was observed for our cockles above 20 mm (SL), further investigation on smaller cockles and the need for larger sample sizes would be required to say for some certainty this is representative for this species.

Temperature and salinity are important natural physical factors that affect marine organisms, and these are highly variable in estuarine and intertidal environments (Kinne, 1971). In these environments, water temperature varies over a tidal cycle. Exposed areas are, however, also subjected to external influence such as direct sunlight during low tidal periods. Newell (1977) demonstrated that *C. edule* has the ability to acclimatize metabolic rate and withstand temperature changes up to 10°C. This adaptation is important as it explains how *C. edule* may regulate its metabolism during times of stress. It may also be a factor in controlling the *Ec* values as the observed temperatures from both of our sites rarely exceeded 10°C from the seasonal mean, which itself was not different between sites (Fig. 8) (Chapter 4). Thermal stress has been associated with interrupting the normal gene expression in the oyster *Crassostrea gigas* (Zhang et al., 2019), resulting in accelerated energy consumption and disrupted the metabolic balance, leaving the oysters less resilient to infection. The impact of thermal stress therefore led to a mass mortality event during the summer (Zhang et al., 2019).

### 5.7 Limitations

All the biochemical component values are dependent on a homogenised sample of all tissues present in half a section of *C. edule*. Utilization of this method allowed for the overall energy status to be estimated and reduced the time necessary for processing the samples for analysis. There are disadvantages in combining entire soft tissue for analyses as it may mask values from individual tissues that could provide information on the organism's response to natural stress. For example, Bayne et al., (1982) found a link between the energy reserves in the mantle tissue of *Mytilus edulis* with gametogenesis. Carbohydrates and proteins were concentrated in the mantle and were influenced by their reproductive stage. Erk et al., (2012) assessed three types of organ from *G. galloprovincialis* and found that the protein and lipid content in mantle tissue was influenced by the sex of the individual and was not, therefore, associated with natural stress but with the individual's physiological changes. Also, the *CEA* value from gill tissues had much lower values compared with the other two organs (mantle and digestive gland) and could not therefore be related to natural stress (Erk et al., 2012). The authors concluded that the digestive gland is best equipped to show changes in natural stress

as its epithelium is negatively affected by contaminants and physiological parameters such as salinity and food availability (Livingstone and Pipe, 1992; Erk et al., 2012). These studies show how individual tissues can have an important bearing on test results and any correlations observed when using whole tissue for analyses should be evaluated accordingly; and it should also be considered when comparing values across studies. Such correlations may misrepresent the results if the homogenisation process is not accurate enough to thoroughly homogenise all tissues together, leading to a bias in the findings. For example; if testing for carbohydrates provides a negative result, then it could be because a greater proportion of the sample analysed is made up of tissue which is low in carbohydrates, e.g. germinal tissue (Gabbot, 1975). Our results are based on the whole organism and should not be used for making direct comparisons of individual tissues across different studies. Future research should investigate what is suitable at the time of sampling and target tissues accordingly. Sample size and the number of replicates used would also improve the accuracy of the results. This study used only sixteen cockles from each site per sampling season. Each cockle was over 20 mm shell length. Using a larger range of sizes would provide information on the energy status of smaller cockles and better represent the size classes of each fishery.

## 5.8 Summary

This study has demonstrated that the health of the cockle stocks in North Wales is extremely variable by nature and does not necessarily follow patterns that can be related to the environment. It was able to show that overall, cockles at Traeth Melynog are at an energetic advantage in terms of the higher *CEA* value, especially during time of year when conditions can be at their harshest and are potentially more resilient to sudden temperature changes or other biotic and abiotic stressors. The reasons why this was the case remain to be determined and further investigation will help to unravel its mysteries. This study did not monitor all biotic or abiotic factors which would naturally place stress on the cockles from both, so is unable to predict the known cause for the relationships in their energetic conditions that were seen. By understanding how *Cerastoderma edule* responds to natural stress, can be imperative to future research and potentially feed into fisheries management decisions. The Cellular Energetic Allocation method allows for an in-situ measurement, which take a snapshot in time. By combining the results with other environmental variables can help build an understanding of the dynamics of the ecosystem and the overall affects it has on the health of *C. edule*. New advancing techniques for measuring *CEA* by using near infra-red spectra (Bartlett et al., 2018)

## Chapter 5

are beginning to be used to help analyse the health of marine organisms and provide an early warning system to infer environmental stress. The biochemical techniques using described in this study allows for *CEA* measurements to be taken at a fraction of time and cost than traditional methods but also facilitate the collection of great quantities of data from more individuals at a greater temporal and spatial scale.

## 5.9 References

- Abe, F.R., Soares, A.M., de Oliveira, D.P. and Gravato, C., 2018. Toxicity of dyes to zebrafish at the biochemical level: Cellular energy allocation and neurotoxicity. *Environmental pollution*, 235, pp.255-262.
- Bagheri, F., Talebi, K. and Hosseiniaveh, V., 2010. Cellular energy allocation of pistachio green stink bug, *Brachynema germari* Kol.(Hemiptera.: Pentatomidae) in relation to juvenoid pyriproxyfen. *African Journal of biotechnology*, 9(35).
- Bartlett, J.K., Maher, W.A. and Purss, M.B., 2018. Cellular energy allocation analysis of multiple marine bivalves using near infrared spectroscopy. *Ecological indicators*, 90, pp.247-256.
- Bayne, B.L. and Bayne, B.L. eds., 1976. *Marine mussels: their ecology and physiology* (Vol. 10). Cambridge University Press.
- Bayne, B.L., Thompson, R.J. and Widdows, J., 1973. Some effects of temperature and food on the rate of oxygen consumption by *Mytilus edulis* L. In *Effects of temperature on ectothermic organisms* (pp. 181-193). Springer, Berlin, Heidelberg.
- Bayne, B.L., Bubel, A., Gabbott, P.A., Livingstone, D.R., Lowe, D.M. and Moore, M.N., 1982. Glycogen utilisation and gametogenesis in *Mytilus edulis* L. *Marine biology letters*, (2).
- Bayne, B.L. and Newell, R.C., 1983. Physiological energetics of marine molluscs. In *The mollusca* (pp. 407-515). Academic Press.
- Beyer, J., Aarab, N., Tandberg, A.H., Ingvarsdottir, A., Bamber, S., Børseth, J.F., Camus, L. and Velvin, R., 2013. Environmental harm assessment of a wastewater discharge from Hammerfest LNG: A study with biomarkers in mussels (*Mytilus sp.*) and Atlantic cod (*Gadus morhua*). *Marine pollution bulletin*, 69(1-2), pp.28-37.
- Bligh, E.G. and Dyer, W.J., 1959. A rapid method of total lipid extraction and purification. *Canadian journal of biochemistry and physiology*, 37(8), pp.911-917.
- Bolaños, R. and Souza, A., 2010. Measuring hydrodynamics and sediment transport processes in the Dee Estuary. *Earth system science data*, 2(1), pp.157-165.
- Boyden, C.R., 1972. The behaviour, survival and respiration of the Cockles *Cerastoderma edule* and *C. Glaucum* in air. *Journal of the marine biological association of the United Kingdom*, 52(03), p.661.
- Callaway, R., Shinn, A.P., Grenfell, S.E., Bron, J.E., Burnell, G., Cook, E.J., Crumlish, M., Culloty, S., Davidson, K., Ellis, R.P. and Flynn, K.J., 2012. Review of climate change impacts on marine aquaculture in the UK and Ireland. *Aquatic conservation: marine and freshwater ecosystems*, 22(3), pp.389-421
- Calow, P. and Sibly, R.M., 1990. A physiological basis of population processes: ecotoxicological implications. *Functional ecology*, 4(3), pp.283-288.
- Cammen, L.M., Corwin, S. and Christensen, J.P., 1990. Electron transport system (ETS) activity as a measure of benthic macrofaunal metabolism. *Marine ecology progress series*, 65(1), pp.171-182.
- Compton, T.J. et al., 2007. Thermal tolerance ranges and climate variability: A comparison between bivalves from differing climates. *Journal of experimental marine biology and ecology*, 352(1), pp.200–211.
- Davis, J.P. and Wilson, J.G., 1983. Seasonal changes in tissue weight and biochemical composition of the bivalve *Nucula turgida* in Dublin Bay with reference to gametogenesis. *Netherlands Journal of sea research*, 17(1), pp.84-95.
- De Coen, W.M. and Janssen, C.R., 1997. The use of biomarkers in *Daphnia magna* toxicity testing. IV. Cellular energy allocation: a new methodology to assess the energy budget of toxicant-stressed *Daphnia* populations. *Journal of aquatic ecosystem stress and recovery*, 6(1), pp.43-55.



## Chapter 5

De Coen, W.M. and Janssen, C.R., 2003. The missing biomarker link: Relationships between effects on the cellular energy allocation biomarker of toxicant-stressed *Daphnia magna* and corresponding population characteristics. *Environmental Toxicology and Chemistry: An international journal*, 22(7), pp.1632-1641.

De Troch, M., Reubens, J.T., Heirman, E., Degraer, S. and Vincx, M., 2013. Energy profiling of demersal fish: A case-study in wind farm artificial reefs. *Marine environmental research*, 92, pp.224-233.

Elliott, M., Burdon, D., Callaway, R., Franco, A., Hutchinson, T., Longshaw, M., Malham, S., Mazik, K., Otto, Z., Palmer, D. and Firmin, C., 2012. Burry Inlet cockle mortalities investigation 2009–2011 (p. 337). Final Technical Report to Environment Agency (Wales), 17 January 2012. Available online at: <http://a0768b4a8a31e106d8b0-50dc802554eb38a24458b98ff72d550b.r19.cf3.rackcdn.com/gewa0112bwap-ee.pdf>.

Erk, M., Muysen, B.T., Ghekiere, A. and Janssen, C.R., 2008. Metallothionein and cellular energy allocation in the estuarine mysid shrimp *Neomysis integer* exposed to cadmium at different salinities. *Journal of experimental marine biology and ecology*, 357(2), pp.172-180.

Erk, M., Ivanković, D. and Strižak, Ž., 2011. Cellular energy allocation in mussels (*Mytilus galloprovincialis*) from the stratified estuary as a physiological biomarker. *Marine pollution bulletin*, 62(5), pp.1124-1129.

Erk, M., Ivanković, D. and Strižak, Ž., 2012. Selection of target mussel tissue for application of cellular energy allocation as a physiological biomarker in native mussels *Mytilus galloprovincialis* (Lamarck, 1819). *Journal of shellfish research*, 31(1), pp.61-68.

Gabbot, P.A., 1975. Storage cycles in marine bivalve molluscs: A hypothesis concerning the relationship between glycogen metabolism and gametogenesis, in: *Proceeding of the 9th European Marine Biology Symposium* (pp. 191-211). Aberdeen University Press.

Gagné, F., Blaise, C., Pellerin, J., Fournier, M., Durand, M.J. and Talbot, A., 2008. Relationships between intertidal clam population and health status of the soft-shell clam *Mya arenaria* in the St. Lawrence Estuary and Saguenay Fjord (Québec, Canada). *Environment international*, 34(1), pp.30-43.

Gallager, S.M. and Mann, R., 1986. Growth and survival of larvae of *Mercenaria mercenaria* (L.) and *Crassostrea virginica* (Gmelin) relative to broodstock conditioning and lipid content of eggs. *Aquaculture*, 56(2), pp.105-121.

Genelt-Yanovskiy, E. et al., 2010. Population structure and growth rates at biogeographic extremes: a case study of the common cockle, *Cerastoderma edule* (L.) in the Barents Sea. *Marine pollution bulletin*, 61(4-6), pp.247–53.

Giarratano, E. and Renaud, P.E., 2013. Seasonal variation in biomarkers in blue mussel (*Mytilus edulis*), Icelandic scallop (*Chlamys islandica*) and Atlantic cod (*Gadus morhua*)—Implications for environmental monitoring in the Barents Sea. *Aquatic toxicology*, 127, pp.21-35.

Gnaiger, E., 1983. Calculation of energetic and biochemical equivalents of respiratory oxygen consumption. In *Polarographic oxygen sensors* (pp. 337-345). Springer, Berlin, Heidelberg.

Gomes, S., Scott-Fordsmand, J. and Amorim, M., 2015. Cellular energy allocation to assess the impact of nanomaterials on soil invertebrates (Enchytraeids): the effect of Cu and Ag. *International journal of environmental research and public health*, 12(6), pp.6858-6878.

Gosling, E. ed., 1992. *The mussel Mytilus: ecology, physiology, genetics and culture* (No. 594.1 MUS). Amsterdam: Elsevier.

Halcrow, 2010. North West England and North Wales Shoreline Management Plan SMP2. Appendix C – Baseline Process Understanding. Report prepared by Halcrow Group Ltd for the North West and North Wales Coastal Group, pp.58.

Hawkins, A. J. S. and Bayne B. L., 1992. Physiological interrelations, and the regulation of production. In: E. Gosling, editor. *The mussel Mytilus: ecology, physiology, genetics and culture*. Amsterdam: Elsevier. pp. 171–222.

## Chapter 5

- Honkoop, P.J.C. and Beukema, J.J., 1997. Loss of body mass in winter in three intertidal bivalve species: an experimental and observational study of the interacting effects between water temperature, feeding time and feeding behaviour. *Journal of experimental marine biology and ecology*, 212(2), pp.277-297.
- Honkoop, P.J.C., Van der Meer, J., Beukema, J.J. and Kwast, D., 1999. Reproductive investment in the intertidal bivalve *Macoma balthica*. *Journal of sea research*, 41(3), pp.203-212.
- Jadhav, M., Bawane, V. and Gulave, A., 2012. Size dependent variation in the rate of oxygen consumption, ammonia and O: N ratio of freshwater bivalve, *Lamellidens marginalis* from Godavari river during monsoon (MS) india. *Trends in Fisheries Research*, 1(2), pp.22-26.
- Kaiser, M.J., Blyth-Skyrme, R.E., Hart, P.J., Edwards-Jones, G. and Palmer, D., 2007. Evidence for greater reproductive output per unit area in areas protected from fishing. *Canadian Journal of fisheries and aquatic sciences*, 64(9), pp.1284-1289
- Kinne, O., 1971. Salinity: animals-invertebrates. In: *Marine ecology, Vol. I. Environmental factors*. Wiley-Interscience, London, Pt. 2, pp. 821-995.
- Kühnhold, H., Kamyab, E., Novais, S., Indriana, L., Kunzmann, A., Slater, M. and Lemos, M., 2017. Thermal stress effects on energy resource allocation and oxygen consumption rate in the juvenile sea cucumber, *Holothuria scabra* (Jaeger, 1833). *Aquaculture*, 467, pp.109-117.
- Leyva, A., Quintana, A., Sánchez, M., Rodríguez, E.N., Cremata, J. and Sánchez, J.C., 2008. Rapid and sensitive anthrone-sulfuric acid assay in microplate format to quantify carbohydrate in biopharmaceutical products: method development and validation. *Biologicals*, 36(2), pp.134-141.
- Livingstone, D. R. & R. K. Pipe. 1992. Mussels and environmental contaminants: molecular and cellular aspects. In: E. Gosling, editor. *The mussel Mytilus: ecology, physiology, genetics and culture*. Amsterdam: Elsevier. pp. 425-464.
- Liu, W., Li, Q. and Kong, L., 2013. Reproductive cycle and seasonal variations in lipid content and fatty acid composition in gonad of the cockle *Fulvia mutica* in relation to temperature and food. *Journal of Ocean University of China*, 12(3), pp.427-433.
- Louis, F., Devin, S., Giambérini, L., Potet, M., David, E. and Pain-Devin, S., 2019. Energy allocation in two dreissenid species under metal stress. *Environmental pollution*, 245, pp.889-897.
- Macrae, K., 2009. Effects on cellular energy allocation and total oxyradical capacity in contamination exposed *Arenicola marina* (Master's thesis).
- Mane, U.H., 1975. Oxygen consumption of the clam, *Katylsia opima* in relation to environmental conditions. *Broteria*, 64, pp.33-58.
- Mathieu, M. and Lubet, P., 1993. Storage tissue metabolism and reproduction in marine bivalves—a brief review. *Invertebrate reproduction & development*, 23(2-3), pp.123-129.
- Matoo, O.B., Ivanina, A.V., Ullstad, C., Beniash, E. and Sokolova, I.M., 2013. Interactive effects of elevated temperature and CO<sub>2</sub> levels on metabolism and oxidative stress in two common marine bivalves (*Crassostrea virginica* and *Mercenaria mercenaria*). *Comparative Biochemistry and Physiology Part A: Molecular & integrative physiology*, 164(4), pp.545-553.
- Meyer, I.J. and Wepener, V., 2008. 'n Voorlopige studie van die opnamekinetika en sellulêre energietoekenning gedurende subdodelike blootstelling aan sink by die Bloukurper (*Oreochromis mossambicus*). *Suid-Afrikaanse Tydskrif vir Natuurwetenskap en Tegnologie*, 27(4).
- Moolman, L.J.H.J., Van Vuren, J.H.J. and Wepener, V., 2007. Comparative studies on the uptake and effects of cadmium and zinc on the cellular energy allocation of two freshwater gastropods. *Ecotoxicology and environmental safety*, 68(3), pp.443-450.

## Chapter 5

- Moon, S.D., Lee, J.H., Sung, C.G., Choi, T.S., Lee, K.T., Lee, J.S. and Kang, S.G., 2013. Cellular Energy Allocation of a Marine Polychaete Species (*Perinereis aibuhitensis*) Exposed to Dissolving Carbon Dioxide in Seawater. *Journal of the Korean society for marine environment & energy*, 16(1), pp.9-16.
- Moore, R.D., Wolf, J., Souza, A.J. and Flint, S.S., 2009. Morphological evolution of the Dee Estuary, Eastern Irish Sea, UK: a tidal asymmetry approach. *Geomorphology*, 103(4), pp.588-596.
- Muyssen, B.T., Janssen, C.R. and Bossuyt, B.T., 2002. Tolerance and acclimation to zinc of field- collected *Daphnia magna* populations. *Aquatic toxicology*, 56(2), pp.69-79.
- Nahrgang, J., Camus, L., Broms, F., Christiansen, J.S. and Hop, H., 2010. Seasonal baseline levels of physiological and biochemical parameters in polar cod (*Boreogadus saida*): Implications for environmental monitoring. *Marine pollution bulletin*, 60(8), pp.1336-1345.
- Nahrgang, J., Brooks, S.J., Evenset, A., Camus, L., Jonsson, M., Smith, T.J., Lukina, J., Frantzen, M., Giarratano, E. and Renaud, P.E., 2013. Seasonal variation in biomarkers in blue mussel (*Mytilus edulis*), Icelandic scallop (*Chlamys islandica*) and Atlantic cod (*Gadus morhua*)—Implications for environmental monitoring in the Barents Sea. *Aquatic toxicology*, 127, pp.21-35.
- Natural England, 2010. The Dee Estuary European Marine Site. Natural England & the Countryside Council for Wales' advice given under Regulation 33(2) of the Conservation (Natural Habitats &c.) Regulations 1994, pp.259
- Navarro, E., Iglesias, J.I.P. & Larrañaga, A., 1989. Interannual variation in the reproductive cycle and biochemical composition of the cockle *Cerastoderma edule* from Mundaca Estuary (Biscay, North Spain). *Marine biology*, 101, pp. 503-511.
- Newell, R. I. E., 1977. The eco-physiology of *Cardium edule* (L.). Ph.D. thesis, University of London, pp.215.
- Newell, R.I.E. and Bayne, B.L., 1980. Seasonal changes in the physiology, reproductive condition and carbohydrate content of the cockle *Cardium* (= *Cerastoderma*) *edule* (Bivalvia: Cardiidae). *Marine biology*, 56(1), pp.11-19.
- Nygård, H., Wallenschus, J., Camus, L., Varpe, Ø. and Berge, J., 2010. Annual routines and life history of the amphipod *Onisimus litoralis*: seasonal growth, body composition and energy budget. *Marine ecology progress series*, 417, pp.115-126.
- Olsen, G.H., Sva, E., Carroll, J., Camus, L., De Coen, W., Smolders, R., Øveraas, H. and Hylland, K., 2007. Alterations in the energy budget of Arctic benthic species exposed to oil-related compounds. *Aquatic toxicology*, 83(2), pp.85-92.
- Olsen, G.H., Carroll, J., Sva, E. and Camus, L., 2008. Cellular energy allocation in the Arctic sea ice amphipod *Gammarus wilkitzkii* exposed to the water soluble fractions of oil. *Marine environmental research*, 66(1), pp.213-214.
- Pontee, N., Allen, E., Pye, K., and Parsons, A., 2013. Dee Estuary. North West Estuaries Processes Reports, Halcrow Group, pp.63. Available at: [https://www.liverpool.ac.uk/~cmi/dee/Dee\\_rep2013.pdf](https://www.liverpool.ac.uk/~cmi/dee/Dee_rep2013.pdf)
- Ramon, M., 2003. Population dynamics and secondary production of the cockle *Cerastoderma edule* (L.) in a backbarrier tidal flat of the Wadden Sea. *Scientia marina*, 67(4), pp.429-443.
- Reise, K., 2003. Metapopulation structure in the lagoon cockle *Cerastoderma lamarcki* in the northern Wadden Sea. *Helgoland marine research*, (56), pp.252-258.
- Rowley, A.F., Cross, M.E., Culloty, S.C., Lynch, S.A., Mackenzie, C.L., Morgan, E., O'Riordan, R.M., Robins, P.E., Smith, A.L., Thrupp, T.J. and Vogan, C.L., 2014. The potential impact of climate change on the infectious diseases of commercially important shellfish populations in the Irish Sea—a review. *ICES Journal of Marine Science*, 71(4), pp.741-759.
- Rueda-Jasso, R., Conceição, L.E., Dias, J., De Coen, W., Gomes, E., Rees, J.F., Soares, F., Dinis, M.T. and Sorgeloos, P., 2004. Effect of dietary non-protein energy levels on condition and oxidative status of Senegalese sole (*Solea senegalensis*) juveniles. *Aquaculture*, 231(1-4), pp.417-433.

## Chapter 5

- Seifter, S., Dayton, S., Novic, B. and Muntwyler, E., 1950. The estimation of glycogen with the anthrone reagent. *Arch. Biochem.*, 25, pp.191-200.
- Simčič, T. and Brancelj, A., 2004. Respiratory electron transport system (ETS) activity as an estimator of the thermal tolerance of two *Daphnia* hybrids. *Journal of plankton research*, 26(5), pp.525-534.
- Simčič, T., Pajk, F. and Brancelj, A., 2010. Electron transport system activity and oxygen consumption of two amphibious isopods, epigeal *Ligia italica* Fabricius and hypogean *Titanethes albus* (Koch), in air and water. *Marine and freshwater behaviour and physiology*, 43(2), pp.149-156.
- Smolders, R., Bervoets, L., De Coen, W. and Blust, R., 2004. Cellular energy allocation in zebra mussels exposed along a pollution gradient: linking cellular effects to higher levels of biological organization. *Environmental pollution*, 129(1), pp.99-112.
- Stoeckmann, A.M. and Garton, D.W., 2001. Flexible energy allocation in zebra mussels (*Dreissena polymorpha*) in response to different environmental conditions. *Journal of the North American Benthological Society*, 20(3), pp.486-500.
- Sung, Chan-Gyoung & Kang, Sin-Kil & Chung, Jiwoong & Park, Dong-Ho & Lee, Jong-Hyeon & Lee, Chang-Hoon, 2016. Evaluation of cellular energy allocation (CEA) in the Manila clam, *Ruditapes philippinarum* as a tool for assessment of contaminated sediments. *The Korean journal of malacology*, 32, pp.45-54.
- Sutherland, W.J., 1982. Spatial variation in the predation of cockles by oystercatchers at Traeth Melynog, Anglesey. II. The pattern of mortality. *The Journal of animal ecology*, pp.491-500.
- Van Cauwenberghe, L., Claessens, M., Vandegehuchte, M.B. and Janssen, C.R., 2015. Microplastics are taken up by mussels (*Mytilus edulis*) and lugworms (*Arenicola marina*) living in natural habitats. *Environmental pollution*, 199, pp.10-17.
- Trindade AB, Pires PJ, Teixeira S, Ferreira AR, Machado D, Anjos CM, MENDES SL, Matias D, Joaquim S and Baptista TM (2019). Study of the reproductive cycle of cockle (*Cerastoderma edule*, Linnaeus, 1758), from Lagoa de Óbidos, Leiria, Portugal. *Front. Mar. Sci. Conference Abstract: IMMR'18 | International Meeting on Marine Research 2018*. doi: 10.3389/conf.FMARS.2018.06.00154
- Vandenbrouck, T., Soetaert, A., van der Ven, K., Blust, R. and De Coen, W., 2009. Nickel and binary metal mixture responses in *Daphnia magna*: molecular fingerprints and (sub) organismal effects. *Aquatic toxicology*, 92(1), pp.18-29.
- Verslycke, T. and Janssen, C.R., 2002. Effects of a changing abiotic environment on the energy metabolism in the estuarine mysid shrimp *Neomysis integer* (Crustacea: Mysidacea). *Journal of experimental marine biology and ecology*, 279(1-2), pp.61-72.
- Verslycke, T., Vercauteren, J., Devos, C., Moens, L., Sandra, P. and Janssen, C.R., 2003. Cellular energy allocation in the estuarine mysid shrimp *Neomysis integer* (Crustacea: Mysidacea) following tributyltin exposure. *Journal of experimental marine biology and ecology*, 288(2), pp.167-179.
- Verslycke, T., Roast, S.D., Widdows, J., Jones, M.B. and Janssen, C.R., 2004. Cellular energy allocation and scope for growth in the estuarine mysid *Neomysis integer* (Crustacea: Mysidacea) following chlorpyrifos exposure: a method comparison. *Journal of experimental marine biology and ecology*, 306(1), pp.1-16.
- Verslycke, T., Ghekiere, A. and Janssen, C.R., 2004. Seasonal and spatial patterns in cellular energy allocation in the estuarine mysid *Neomysis integer* (Crustacea: Mysidacea) of the Scheldt estuary (The Netherlands). *Journal of experimental marine biology and ecology*, 306(2), pp.245-267.
- Voets, J., Talloen, W., de Tender, T., Van Dongen, S., Covaci, A., Blust, R. and Bervoets, L., 2006. Microcontaminant accumulation, physiological condition and bilateral asymmetry in zebra mussels (*Dreissena polymorpha*) from clean and contaminated surface waters. *Aquatic toxicology*, 79(3), pp.213-225.
- Wang, X., Wang, L., Yao, C., Qiu, L., Zhang, H., Zhi, Z. and Song, L., 2012. Alternation of immune parameters and cellular energy allocation of *Chlamys farreri* under ammonia-N exposure and *Vibrio anguillarum* challenge. *Fish & shellfish immunology*, 32(5), pp.741-749.

## Chapter 5

- Whitlow, L., Smit, N., Van Vuren, J.H.J. and Wepener, V., 2008. Cellular energy allocation in fish families of the Okavango River, Botswana, during the annual feeding migration. *Suid-Afrikaanse Tydskrif vir Natuurwetenskap en Tegnologie*, 27(4).
- Whitton, T.A., 2013. Processes Controlling Spatial and Temporal Variations in Cockle *Cerastoderma Edule* (L.) Abundance and Distribution (Doctoral dissertation, Bangor University (Marine Biology)).
- Widdows, J. and Bayne, B.L., 1971. Temperature acclimation of *Mytilus edulis* with reference to its energy budget. *Journal of the marine biological association of the United Kingdom*, 51(4), pp.827-843.
- Widdows, J., 1978. Physiological indices of stress in *Mytilus edulis*. *Journal of the marine biological association of the United Kingdom*, 58(1), pp.125-142.
- Widdows, J. and Johnson, D., 1988. Physiological energetics of *Mytilus edulis*: scope for growth. *Marine ecology progress series*, pp.113-121.
- Widdows, J. and Donkin, P., 1992. Mussels and environmental contaminants: bioaccumulation and physiological aspects. *The mussel Mytilus: Ecology, physiology, genetics and culture*, 25, pp.383-424.
- Wolff, W.J. et al., 1993. Biomass of macrobenthic tidal flat fauna of the Banc d'Arguin, Mauritania. *Hydrobiologia*, 258(1-3), pp.151-163.
- Wootton, E.C., Dyrinda, E.A. and Ratcliffe, N.A., 2003. Bivalve immunity: comparisons between the marine mussel (*Mytilus edulis*), the edible cockle (*Cerastoderma edule*) and the razor-shell (*Ensis siliqua*). *Fish & shellfish immunology*, 15(3), pp.195-210.
- Xiao, B.C., Li, E.C., Du, Z.Y., Jiang, R.L., Chen, L.Q. and Yu, N., 2014. Effects of temperature and salinity on metabolic rate of the Asiatic clam *Corbicula fluminea* (Müller, 1774). *SpringerPlus*, 3(1), p.455.
- Yeats, P., Gagné, F. and Hellou, J., 2008. Body burden of contaminants and biological effects in mussels: an integrated approach. *Environment international*, 34(2), pp.254-264.
- Zhang, H., Wang, H., Chen, H., Wang, M., Zhou, Z., Qiu, L., Wang, L. and Song, L., 2019. The transcriptional response of the Pacific oyster *Crassostrea gigas* under simultaneous bacterial and heat stresses. *Developmental & comparative immunology*.

## General Discussion

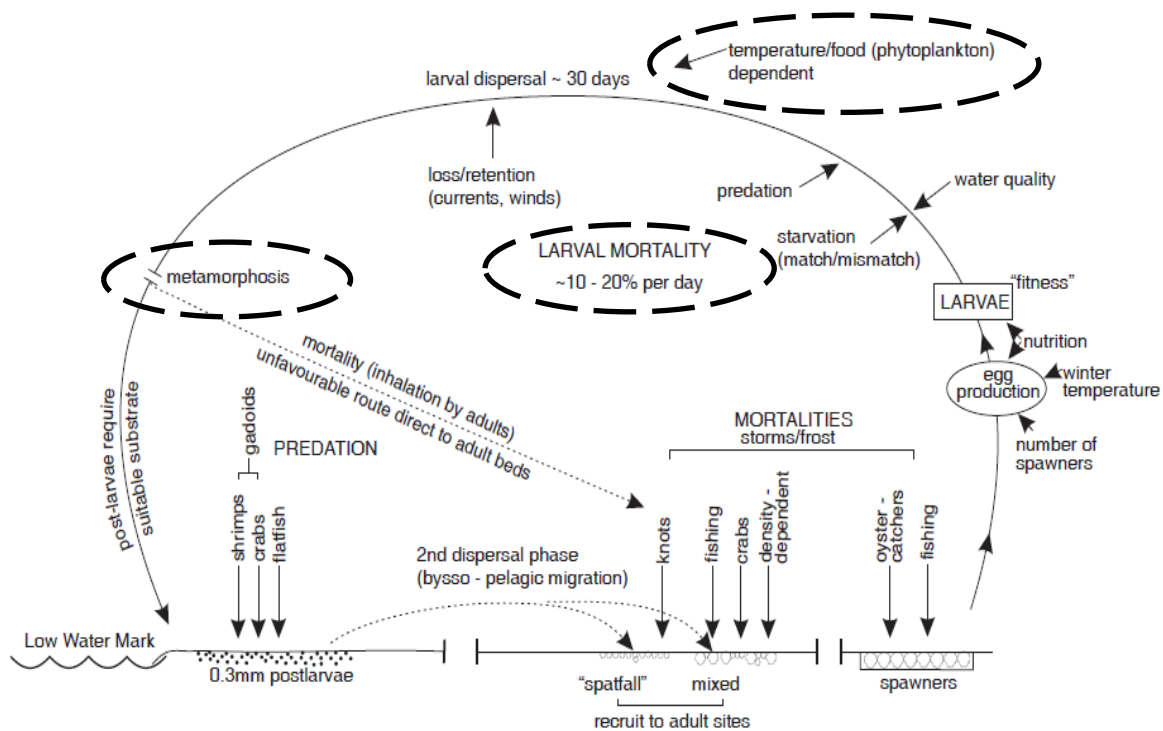
### 6.1 Introduction

This thesis has addressed the spatial and temporal variability on aspects of the life history of *Cerastoderma edule*. In doing so, it has uncovered clear separation between the sampled cockle fisheries located in North Wales on larval growth and survival (Chapter 2), the parasite and pathogen community structure (Chapter 3) and the biochemical composition (Chapter 4) within them. Intertidal areas in which *C. edule* can be found are dynamic and expose marine organisms living there to naturally changing stressors. Both the larvae and adult cockles are tolerant to the majority of the conditions they are presented with, but like all biological organisms, there are limitations. *C. edule* requires soft sediment habitats that are dynamic by nature, and thus its distribution is limited to temperate estuarine or tidal flat environments where the conditions can reach the upper and lower limits of their tolerance (Malham et al., 2012). As a consequence, *C. edule* has evolved to adapt and thrive in such environments (Hawkins and Bayne, 1992). Where they occur in dense biomass, they provide economic and environmental benefits (Beaumont et al., 2007). They provide a food source to migrating and over wintering seabirds (Camphuysen et al., 2002; Goss-Custard et al., 2004). They have positive ecosystem level effects through the creation of habitat for other organisms. Through bioturbation they improve oxygen content of the upper sediment layers and they recycle nutrients to the benthic habitat, increasing biodiversity (density dependant) (Ciutat et al., 2006; Cesar, 2009).

### 6.2 Spatial variability in larval growth and survival.

Differences have been identified in the biological processes of *C. edule* larvae during their pelagic stage of development (Chapter 3). Larvae generated from Traeth Melynog were at a slight advantage to those derived from the Dee estuary due to higher growth rates and lower mortality rates (Chapter 3, Fig. 8 & 9). Results found that important trophic level interactions can be displaced. Delayed metamorphoses and reduced survival will be affected in years when there is a mismatch between the presence of *C. edule* larvae in the water column and the availability of food (Cushing, 1975, 1990). This was particularly important at colder temperatures (10°C) and may have significant implications on recruitment to a population and the knock-on effects that reduced settlement can have on higher trophic level species

(Camphuysen et al., 2002; Goss-Custard et al., 2004). *C. edule* larvae need to overcome many environmental and physiological variables to reach the settlement phase and recruit to the population (Fig. 1) and it is not only temperature and food availability that will determine their success. Temperature, salinity, food, density, predation, larval development time, time of metamorphose, settlement location, adult condition and previous extreme weather patterns all play some role in assuring that cockle beds remain stocked and in a healthy state via larval recruitment (Fig. 1) (Dare et al., 2004).



**Figure 1.** Schematic diagram of the environmental and anthropogenic pressures on *Cerastoderma edule* larvae which influence their survival and chance of successful recruitment to the adult population. Taken and adapted from Dare et al., (2004). Dashed circles illustrate environmental variables covered in Chapter 2.

Research specifically targeting the developmental stages for *C. edule* is relatively immature and many questions relating to the effect of the environment remain unanswered (Creek, 1960; Kingston 1974; Boyden, 1971; Pronker et al., 2015; Trindade et al., 2019). Knowledge of their biological response to environmental parameters can be supported by using other bivalve species that coexist with *C. edule*, for example *Macoma baltica* (Bos et al., 2007) and *Mytilus edulis* (Bayne, 1965; Pronker et al., 2008). The larval experiments in chapter 3 found that *C. edule* larvae were difficult to generate and keep under laboratory conditions. It required the design of a unique system to capture fertilised eggs and multiple preliminary

attempts to generate larvae were necessary to find the most successfully protocol. The best results came from using high densities of adult cockles that were left to spawn in the tanks for 24 hours as spawning did not immediately commence post thermal shock. The duration of the spawning process did have some negative impact on water quality due to the high densities of adults used. Mortality of adults would occur in the tank, so it was important these were removed. Faecal material was also expelled from the adult cockles and was unavoidable. To reduce the amount of faecal material within the spawning system, the broodstock were placed in chilled filtered seawater prior to spawning. Other methods used to extract gametes from bivalve molluscs include gamete stripping from fully mature *Crassostrea gigas* (Pacific oyster) or injecting serotonin (Helm, 2004) or KCI (Beaumont and Budd, 1982) into the mantle cavity of *M. edulis* to induce gamete release (Galley et al., 2010). For cockles, as their eggs pass down the oviducts, they undergo a maturation process, thus stripping is not a viable option (Boyden, 1971). Thermal shock (used in Chapter 3) is consider the least invasive and damaging however any induction carries the risks that eggs, and sperm may not have completed the full gametogenic cycle and the viability of the gametes could be reduced. High mortality and/or arrested development post fertilisation may be more frequent (Chapter 3, Fig. 10 & 11).

#### **6.4 Relationship between spawning and energetic content**

A difference in the spawning cycles of *C. edule* between the two cockle fisheries was observed. The Dee estuary displayed a shorter spawning window, e.g. from the time of first spawn until their gonads were considered spent, and those from Traeth Melynog were able to be successfully spawned later in the season. *CEA* values support the understanding that gametogenesis requires stores of carbohydrates, lipids and proteins (Trindade et al., 2019) and spawning is costly in terms of metabolic rate (Elliott et al., 2012) (Chapter 5). In fact, spawning requires a significant amount of the total amount of energy available (*Ea*) and lipid content have been shown to decrease as a result of spawning (Elliott et al., 2012). The high *CEA* values from Traeth Melynog during the winter (Chapter 5, and Fig. 2d) suggests these cockles were storing energy in preparation to spawn. Spawning attempts in the laboratory using cockles from Traeth Melynog at the same time of year did not produce any results. The gonad maturation stage showed cockles screened for parasites at the same time of year were at stage 3 (Appendix, Table A1). The mean sediment temperature was around 7°C, much less than their optimal spawning range of 13 – 15 °C (Boyden, 1971; Rueda et al., 2005). By the spring, the *CEA* value



from Traeth Melynog dropped, an indication of spawning activity between these sampling seasons. For the larval experiment in Chapter 3, larvae were produced from Traeth Melynog broodstock in July 2015, between the spring and summer. It is entirely likely that they had already spawned and were building up their energy reserves again ready for subsequent spawns (Chapter 5, Fig. 2d). The sediment temperature at this time was much warmer, reaching their optimal range (Chapter 4, Fig. 19) (Boyden, 1971; Rueda et al., 2005). When cockles from the Dee estuary were spawned for the laboratory experiments, they were just reaching their peak *CEA* value, an indication they had yet to spawn in the wild. Like those from Traeth Melynog, they were also unable to be spawned early in the season. However, notable differences in the gonad maturation stages between sites were observed. Thirty-three percent of the cockles screened from the Dee estuary were at stage 4. Interestingly, there was a difference in the sex and size of the cockle in relation to the gametogenic cycle. Ripe females accounted for 18% of the total and were all over 20mm in shell length, whereas 14% were ripe males between 10 – 20mm shell lengths (Appendix, Table A2). This suggests that larger females mature earlier in the season compared to males in the same size class. *C. edule* collected from the Dee were not able to be induced to spawn in the laboratory until the end of April 2015, even though observations individual's gonad maturation stages were classed as ripe (Appendix, Table A1). Our findings illustrate that environmental conditions play a major role in determining the gametogenic stage and time of spawning of *C. edule* (Kingston, 1974; Martinez-Castro and Vázquez, 2012).

In bivalve molluscs, lipid content is mainly concentrated and stored in the gonads and the digestive gland but is also distributed throughout the different organs (Wenne and Polak, 1992). Reserves are important to developing embryos, and therefore the larvae, especially during stressful conditions (Utting and Milican, 1997). It has been shown that in the bivalves *Mercenaria mercenaria* and *Crassostrea gigas*, the greater the lipid content in eggs, the greater the chance larvae have to surviving to the pediveliger stage (pre-settlement) (Gallager and Manw, 1986). Honkoop et al., (1999) has shown the lipid content in eggs can reach 11% for *Cerastoderma edule*, 20% in *Mytilus edulis* and over 30% in *Macoma balthica*, highlighting that egg content can vary considerable between species. The lipid values observed in these experiments (Chapter 5, Fig. 3c) are high in comparison to other similar studies (Elliott et al., 2012) and the reason behind this is unclear. We are able to rule out any storage of lipids in the developing eggs from females as a cause for the high values as it did not differ from the males sampled. In fact, overall mean lipid content in the winter at Traeth Melynog, was slightly higher

in males. The biochemical analysis used half cockles and homogenised all tissues and organs together. Separating out the values specifically associated to the gonads was not possible. Other explanatory factors may include stomach and digestive gland content containing phytoplankton, which has been shown to contain high concentrations of lipids (Helm and Bourne, 2004; Batista et al., 2014). Sampling was always performed on an ebbing tide with the cockle beds visited soon after exposure. Cockles would have only recently ceased feeding and burrow into the sediment. Many of the samples from the histology screening from Chapter 3 contained visible phytoplankton cells in stomach, leading to suggest that stomach contents could have driven up the lipid values. Alternatively, Traeth Melynog may be exposed to greater concentrations of phytoplankton, than the Dee estuary. Coastal areas in the Irish sea can contain around 23mg of chlorophyll  $m^{-3}$  during the spring phytoplankton blooms, whereas Liverpool Bay, the area at the mouth of the Dee estuary, can have up to 44 mg chlorophyll  $m^{-3}$  (Gowen and Stewart, 2005). Peak phytoplankton blooms typically take place in the spring in the Irish Sea (Pingree et al., 1976.), and it may well have coincided with our sampling period during the spring period, but unlikely to have occurred during the winter when highest lipid concentration values were observed. It can be concluded that other factors that were not tested maybe responsible for the largest lipid values observed. Rescreening the slides of the cockles used in the *CEA* analysis may provide some correlation between individual's lipid content and gut content but being able to quantify with the small sample sizes used for *CEA* would be difficult. To avoid gut content in the samples, further work should ensure cockles are placed in clean filter seawater so they can expel stomach contents and excrete faecal material. There are pitfalls taking this approach as a) there is increasing stress upon the organisms through exposing them to temperature changes and b) they will continue to metabolise the energy reserves thus reducing the accuracy of the biochemical analysis.

In general, the *CEA* values show that cockles from Traeth Melynog had a greater energy status and thus, potentially more energy available to spawn than there is for those in the Dee estuary, but is dependent on season (Chapter 4, Fig. 2d). It may explain why growth rates were found to be less variable and mortality was lower in the larvae generated from TM where reared at higher temperatures, even if they were spawned later in the season. To investigate further the relationship between parental *CEA* in relation to their larvae growth and mortality, studies will benefit by recording the average stage of gametogenesis alongside the energetic content in the population where broodstock are collected. Sampling could also be conducted on a shorter

(weekly) temporal scale (Elliott et al., 2012) during the spawning season to identify within season changes and improve accuracy of the findings.

### 6.5 *Effect of parasites on spawning success*

*Bucephalus minimus* is well known to cause castration in adult cockles (Carballal *et al.*, 2001; Pina *et al.*, 2009; Longshaw and Malham, 2013) where it can have a significant effect on the reproductive output and quality of the gametes released. The prevalence of infection by *B. minimus* in the Dee estuary was at its highest in the spring, but only accounting for 10% of the of the cockle population (Chapter 4, Fig. 2 and Fig. 7). The exact levels of *B. minimum* infection in the spawning stock was unable to be determined as the collection of adults for Chapter 4 & 5, and those collected for broodstock were offset from each other. However, as the prevalence of *B. minimus* was low either side of our spawning, it is not considered that this parasite has any impact on the spawning success in Chapter 3. The infection rate of *B. minimus* was similar to observations made during the recognised spawning season of *C. edule* from the Dee estuary and Burry Inlet from 2009 – 2011 (Elliott et al., 2012). Infection in the Dee estuary was prevalent in 3 – 7% and in the Burry Inlet, was prevalent in 10 – 25% (Elliott et al., 2012) of the cockle stocks. The Burry Inlet also had a 20% infection of *B. minimus* in 1999 (Elliott et al., 2012). If infection levels are high during the spawning season, as observed at Arcachon Bay, France with a 40% prevalence of *B. minimus* (Magalhães et al., 2015) then it can be expected to have a significant impact to the population's reproductive ability. Further research on the severity *B. minimus* infection and its correlation with reproductive output and gamete condition will help to understand the impact low levels of infection have on *C. edule*. It is important to note that in this research *B. minimus* infection was not restricted to mature cockles. We observed it in cockles from all size classes and found a minimum size of infection was 4.94mm shell length (Fig. 2). During histopathology screening (Chapter 4) a single female collected from the Dee estuary during the spring was identified to contain ripe eggs. Cockles are assumed to mature in their 2<sup>nd</sup> year, around 18 months or between 15 – 20 mm in size (Orten, 1926; Hancock & Franklin, 1972; Seed & Brown, 1977). Therefore, infection of *B. minimus* could have important implications to smaller cockles that have a lower reproductive output (Tyler-Walters, 2007).

Investigating parasitic infections in larvae and from recently settled spat has received little attention within the current available literature (Longshaw and Malham, 2013). In an

attempt to bridge this knowledge gap, we took the laboratory reared larvae left over from the growth experiments and placed them in a large holding tank containing filtered seawater. These were reared until reaching a shell length of 5 mm. Thirty-six individuals then underwent the same histological process and screening as described in Chapter 4. None of these individuals showed any pathological response related to the parasitic groups observed from wild caught individuals. It was therefore concluded that there is no parental transmission or inheritance from larvae spawned and reared under sterile conditions. These findings can be important consideration in studies looking to develop aquaculture methods of *C. edule* (Pronker et al., 2015).

## 6.6 *Parasite community structure*

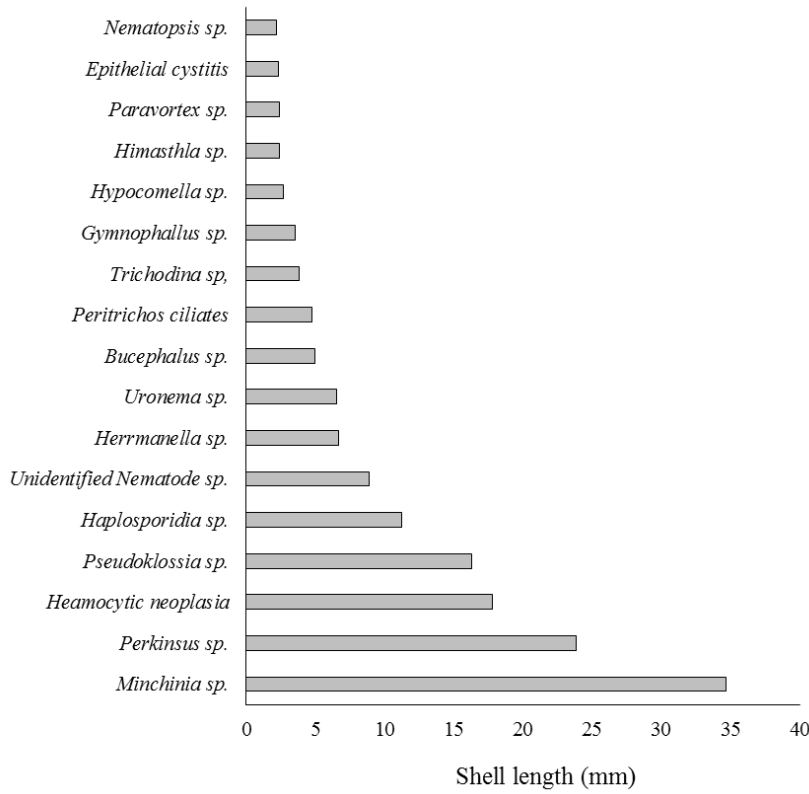
Investigation of the parasite and pathogen community structure of the two cockle populations were able to show that there was a similar but significant difference between the sites in the parasites they host (Chapter 4, Fig. 5 & 18). The prevalence of individual parasitic groups also changed markedly between sampling seasons (Chapter 4, Fig. 5). It is not unexpected that there was this spatial and temporal variation in the community between the sites. Research conducted in North West Spain has also found a variation in the abundance of separate parasitic groups and was able to conclude that northern estuaries had a higher prevalence of most groups of parasites compared to southern estuaries (Carballal et al., 2001). *C. edule* are able to cope with high levels of infection and can be host many separate species of parasites (Longshaw and Malham, 2013) but it is usually a few selective species which can have a significant impact. This research identified 16 different groups of parasites at Traeth Melynog and 15 from the Dee estuary. Many of these did not induce any obvious negative biological or physiological response in their host. Research in the Burry Inlet, South Wales and in the Dee estuary has shown these cockle populations contain a similar amount: Burry Inlet, 13 groups in 1999 and 18 groups in 2009; and from the Dee estuary, 15 groups in 2009 (Elliot et al., 2012). Carballal et al. (2001) identified 13 groups from Galicia, Spain but did not differentiate between digenean parasites. Our results did not identify any group that has not been identified before in Wales, but it was able to show that there are some groups present (*Bucephalus* spp., *Gymnophallus* spp., *Haplosporidia* spp., *Himasthla* spp., *Minchinia* spp. and haemocytic neoplasia, Chapter 4) which can have a direct and/or indirect negative impact if

outbreak of infection or excessive prevalence are observed within populations (Longshaw and Malham, 2013).

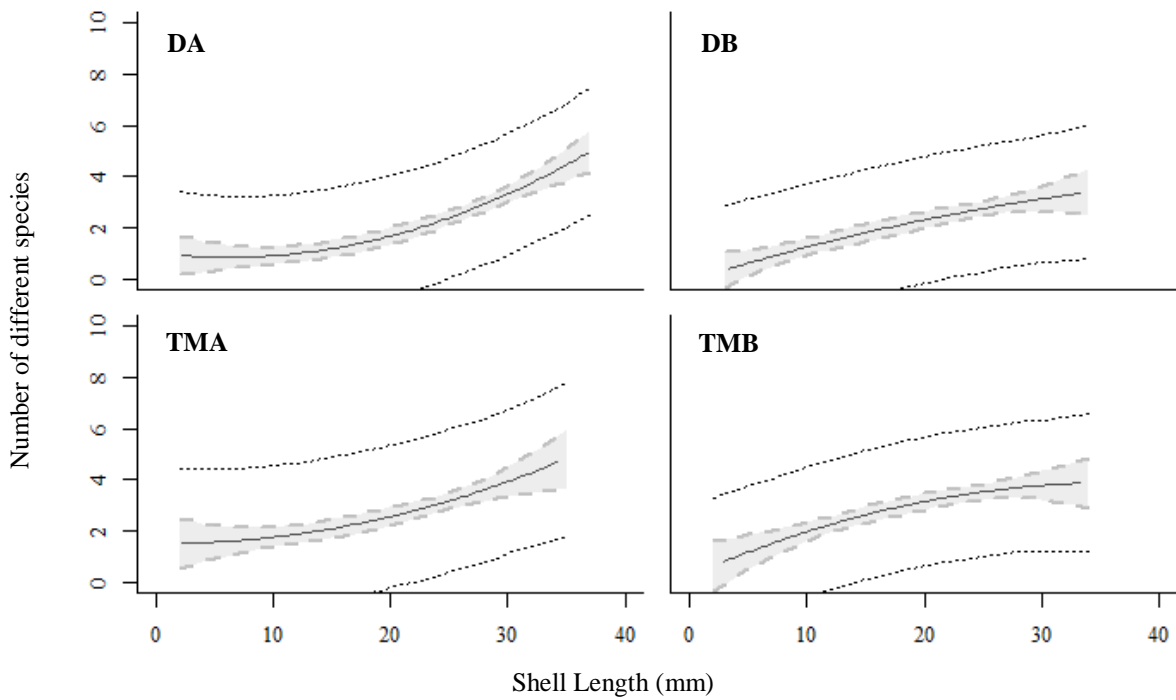
To improve the long term understanding of the parasitic community in North Wales, screening should be conducted on a monthly scale, over a long period of time. The method used to screen for parasites in this study can be costly, time consuming and require specialised knowledge of parasite identification. However, it provides a greater accuracy for identifying parasites at the cellular level than methods that only identify macro parasites. Evidence suggests the genetic analysis can further improve the understanding of parasite communities in marine organisms. Ramilo et al. (2018) identified the presence of *Minchinia* spp. and *Haplosporidia* spp. from cockles collected from Portugal by using genetic analysis even though they were not identified in histology slides. The benefits of DNA analysis are that it can improve our understanding of the parasite community structure by targeting groups that negatively impact the cockle stocks which are not visible in histology slides and, provide advanced warning of potential outbreaks from groups of most concern that will be beneficial to fisheries management. It can also provide some assurance for positive identification and spatial distribution of a particular species, especially during the different stages of infection, or by highlighting those that are covert by nature (Lynch et al., 2014; Ramilo et al., 2018; Robledo et al., 2018).

The cockles screened for parasitic infections ranged from 2 mm to 36 mm. Of the 802 cockles, the total amount that were screened, there is a minimum size limit for all of the parasitic groups identified (Fig. 2). This information (not included in the analysis of Chapter 3) illustrates that juvenile cockles can become infected by the majority of the different groups at a very early age. Therefore, size of the cockle does not mean they are immune to any of the negative effects that infection brings. It is not necessarily the infection of a single species that can prove detrimental to an individual but a combination due to extra stress infection may pose to individuals (Babirat et al., 2004; Woolmer et al., 2013). As cockles grow and age, they accumulate a greater diversity of parasites due to the increased biological functioning (de Montaudouin et al., 2012). Our findings were also able to show that for both of our sampling sites, as cockles increase in size, the number of different species that are host to also increased (Fig. 3).

## Chapter 6



**Figure 2.** Minimum size of *Cerastoderma edule* infected with each of the identified parasitic groups from Chapter 3.



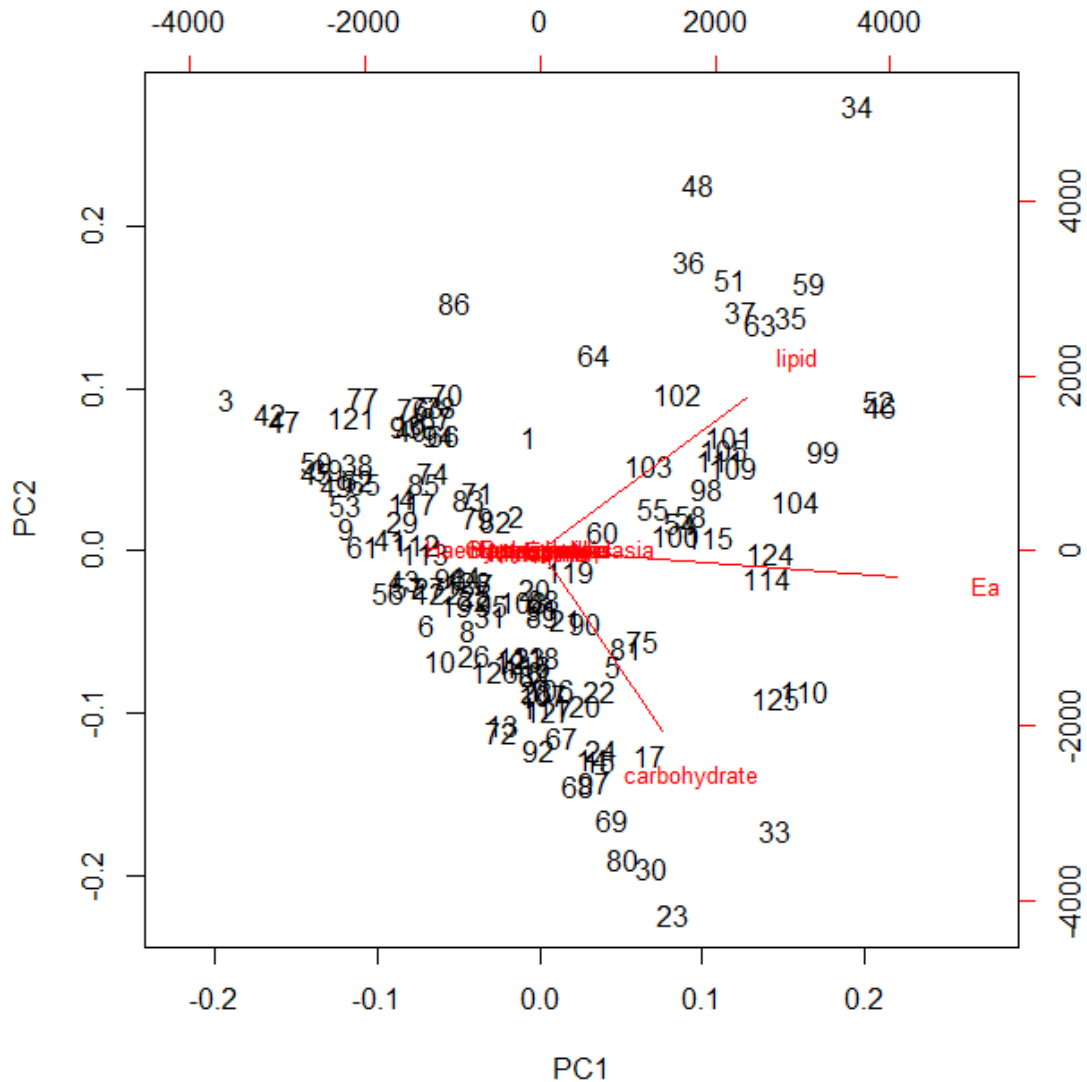
**Figure 3.** Average number of different species of parasites in relation the shell size of *Cerastoderma edule* within each of the sampling sites. Grey area represents the 95% confidence interval and the dotted line is the standard deviation.

### 6.7 Parasite community structure and Cellular Energetic Allocation

The energetic status measured using Cellular Energetic Allocation methods, of *Cerastoderma edule* from both of the cockle fisheries was highly variable throughout the sampling period (Chapter 5, Fig. 2a,d). The results showed that there was a significant separation in *CEA* between each site, but likely to be a result of the high lipid values observed which were unexplained (Chapter 5, Fig. 3a,c). Infection by parasites undoubtedly causes undue stress to the organism and it has been shown that can reduce burrowing efficiency (Desclaux *et al.*, 2002; Morgan *et al.*, 2012; Diaz *et al.*, 2016), increase energy expenditure (Javanshir, 2001); reduce respiration and oxygen uptake (Javanshir, 2001; Elliott *et al.*, 2012); reduce their spawning capabilities and weaken the cockles by absorbing their stores of lipids and carbohydrates (Longshaw and Malham, 2013). Having less energy, increases their susceptibility to other infections which in turn creates a cycle where further infections of different diseases and parasites can accumulate in the cockle (Thébault, 2001; Elliott *et al.*, 2012; Morgan *et al.*, 2012). Synthesis of proteins can also be interrupted during gametogenesis and weaken cockles even further in an energetically demanding period of time where energy stores are vital to ensure successful reproduction (Baudrimont *et al.*, 2006).

In an attempt to understand the relationship between the parasite groups identified which are known to cause significant harm to individuals and populations (*Bucephalus* spp., *Gymnophallus* spp., *Haplosporidia* spp., *Himasthla* spp., *Minchinia* spp. and Haemocytic neoplasia) and the energy content of the individual cockles, a principle component analysis was performed (Fig. 4). Results showed that the first two axis accounted for 98% of the variability between cockles (Fig. 4). The first axis explained 75% of the total variance and displayed positive loadings of the total energy available (*Ea*), lipid content and to a less of a degree, the carbohydrate content. There was no clear relationship with any of the parasite group's (seen by the centre cluster of components). These patterns in distribution of the principle components support the previous observations we have made in Chapters 4 and 5, that there are small differences in the parasite community structure between sites and large variabilities in energetic values. As half cockles were used in the biochemical analysis (Chapter 4), it is extremely difficult to relate the values to any infection as it incorporates values from other tissues or external factors (e.g. stomach content) that will mask relationships, especially if small. To overcome this issue, future studies should address ways to adapt the analysis by selecting tissues or organs to target specific parasites. For example, selecting the foot to target

*Himasthla* spp. or the gonad for *Bucephalus* spp. (Chapter 1, Fig. 2). This would of course require the histopathology screening to be performed first, so it can determine what cockles to select for the biochemical analysis. Only then by combining the histopathology results with the CEA values, can any real assumptions be made on the impact these infections have on the health of *C. edule*.



**Figure 4.** Biplot of first two components of the Principle Component Analysis (PCA) for the similarity matrix for parasite community (*Bucephalus* spp., *Gymnophallus* spp., *Haplosporidia* spp., *Himasthla* spp., *Minchinia* spp. and Haemocytic neoplasia) and total energetic values (total carbohydrates, total lipids, total protein, total *Ea*, total *CEA* and total *Ec* in each of the samples. Numbers represent sites and bed: Sites: DA = 1-32, DB = 33 - 64 TMA = 65-96 & TMB = 97-128. Order of seasons within each site ( $n=8$ ): autumn, winter, spring & summer.



### 6.8 *Implications to the cockle fisheries in response to a changing environment*

Cockle populations are reliant on stock replenishment from the settlement of larvae, as too are the commercial fisheries. Cockles are one of the best adapted marine organisms to survive the challenging intertidal environment of the daily fluctuations in tidal, temperature and salinity extremes. However abiotic factors such as these do not only affect the cockle, but also play a large part in determining the distribution of parasites and the infectious susceptibility of their hosts. As seawater temperature is predicted to increase over the next century, this could have important implications to the survivability of cockle stocks and may show more typical and atypical mortality events happening as a result of increased parasitic influences. (Woolmer et al., 2013).

Projected increase in temperature has been linked to altering the balance of infection by trematodes and the cockles can become less resilient to the infection (Magalhães *et al.*, 2018). Excessive heat not only increases an organism's metabolic rate, it can also disrupt the expression of genes involved in immune response and metabolism as seen in *Crassostrea gigas* (Zhang, et al., 2019). This then has knock on effect as its resilience to infections is reduced leading to greater infection levels and the potential to lead to mass mortality events (Zhang, et al., 2019). It can also be expected that higher temperatures will increase the impact parasitic infection has on its host at the cellular level (Magalhães *et al.*, 2018). Higher temperatures may also lead to higher salinities during low tidal periods as a result of evaporation during warm summer days. This then increasing the energetic consumption of *C. edule* and places more stress up on the individuals (Erk et al., 2012). Lower salinities on the other hand can lead to a reduction in the levels of the cockle's antioxidant defence (Magalhães *et al.*, 2018). This may be of particular concern to those living in the lower reaches of estuaries near to the freshwater source, especially when coupled when excessive rainfall events. Increase in CO<sub>2</sub> as a result of climate change can not only increase infection prevalence, but similar to salinity can also, reduce their metabolic rate. Their calcification rate also decreases under hypercapnia (Ong et al., 2017). Another factor to consider is the parasite mortality threshold. As temperatures rise this may decrease. Increased levels of infection, combined with higher temperatures can bring with it mortality events even when low prevalence in the population is observed (Gam et al., 2008). A rise in temperatures increase their pCO<sub>2</sub> rate. Placing them under stress. Such impacts could be problematic for developing larva. Research into the effect of ocean acidification will help to understand to how larvae respond and if, like this research, identify if certain

populations depending on location are more adapted to withstand any negative effects from these abiotic factors.

The impacts of a changing climate on recruitment is also an important consideration in terms of the sustainability of cockle stocks, and thus, the commercial fisheries it supports. The environment can determine the onset or delay of gametogenesis spawning events (Morgan et al., 2013). In order to have a sustainably managed cockle fisheries it is vitally important that those responsible take into consideration the larval cycle and its response to environmental variables. Predicting when and where spawning takes place, how long larvae remain in the water column and subsequently the transitional period through to the settlement phase is key for fisheries management. In future, testing how cockle larvae respond to combinations of environmental stimuli and testing which senses are used during cockle larval development and settlement can all help to unravel this important transition from pelagic to benthic ecosystems (Kingsford et al. 2002). It is important that the larvae stage of *C. edule* receives targeted studies in relation to the environment and the unknown pathological effects. Research on genetic analysis of individual cockles will also improve our understanding on stock recruitment processes and better aid fisheries management procedures (Coscia et al. 2012; Malham et al. 2012) and new techniques for analysing in-situ *CEA* values using spectrometry may in future provide accurate results that can be used in the management of these vitally important fisheries. Further investigation into parasites and pathogens and the knock-on effects of ocean acidification brought on by climate change are equally important and should be addressed (Kurihara 2008; Longshaw & Malham 2012). Knowledge of parasites present in the cockle fishery can help in decision making for fisheries management by highlighting potential areas where infection may or may not be prevalent. Mitigation measures can then be put in place, especially if it relates to biosecurity hazards. The long-term management of cockle fisheries in North Wales and across the UK rely on the understanding of the complex processes that take place at all temporal and spatial scales.

## 6.9 Overall Summary

This research has covered some of the complex biotic and abiotic factors influencing different parts of *Cerastoderma edule*'s life history and the important role *C. edule* has in the ecosystem functioning of intertidal flats and estuarine habitats. It has been able to show that larvae respond well to warmer seawater than they would otherwise experience in temperature environments for growth and survival. It has shown there is evidence to suggest larval quality between both of the cockle fisheries in North Wales may be different. It has improved our understanding of the prevalence's some of the most influential parasites that *C. edule* is host too through its life and the implications these parasites can have to the individual. It also highlighted that the energetic content of the cockles varies significantly across the different sites and is not necessarily representative of the sampling season. Each population of *Cerastoderma edule* is influenced by a unique set of environment variables that control their biological processes. By understanding the spatial and temporal distribution of parasites and diseases, of the cockles and how these shape host population dynamics, is important for the management of cockle beds to assess the benefit to the cockles and all who depend on the resource. As fisheries and aquaculture businesses are playing an imperative role in supplying nutritional and protein needs too much of the world's population and the supply for their products has dramatically increased over the last half century (FAO, 2018) It is essential that shellfisheries management is adequately informed of the biological and environmental processes that are controlling the population dynamics of stock in order to make informed decisions for their future sustainability.

## 6.10 References

- Babirat, C., Mouritsen, K.N. and Poulin, R., 2004. Equal partnership: two trematode species, not one, manipulate the burrowing behaviour of the New Zealand cockle, *Austrovenus stutchburyi*. *Journal of helminthology*, 78(3), pp.195-199.
- Baudrimont, M., de Montaudouin, X., Palvadeau, A., 2006. Impact of digenean parasite infection on metallothionein synthesis by the cockle (*Cerastoderma edule*): a multivariate field monitoring. *Marine pollution bulletin*, 52, pp. 494-502.
- Beaumont, N.J., Austen, M.C., Atkins, J.P., Burdon, D., Degraer, S., Dentinho, T.P., Deros, S., Holm, P., Horton, T., Van Ierland, E. and Marboe, A.H., 2007. Identification, definition and quantification of goods and services provided by marine biodiversity: implications for the ecosystem approach. *Marine pollution bulletin*, 54(3), pp.253-265.
- Beaumont, A.R. and Budd, M.D., 1982. Delayed growth of mussel (*Mytilus edulis*) and scallop (*Pecten maximus*) veligers at low temperatures. *Marine biology*, 71(1), pp.97-100.
- Bos, O.G., Philippart, C.J. and Van der Meer, J., 2007. Effects of temporary food limitation on development and mortality of *Macoma balthica* larvae. *Marine ecology progress series*, 330, pp.155-162.
- Boyden, C.R., 1971. A comparative study of the reproductive cycles of the cockles *Cerastoderma edule* and *C. glaucum*. *Journal of the marine biological association of the United Kingdom*, 51(03), pp.605-622.
- Camphuysen, C.J. et al., 2002. Mass mortality of common eiders (*Somateria mollissima*) in the Dutch Wadden Sea, winter 1999 / 2000: starvation in a commercially exploited wetland of international importance. *Biological conservation*, 106, pp.303-317.
- Carballal, M.J., Iglesias, D., Santamarina, J., Ferro-Soto, B. and Villalba, A., 2001. Parasites and pathologic conditions of the cockle *Cerastoderma edule* populations of the coast of Galicia (NW Spain). *Journal of Invertebrate Pathology*, 78(2), pp.87-97.
- Cesar, C., 2009. The roles of the cockle *Cerastoderma edule* L. on ecosystem functioning: cockle comings and goings. University of Liverpool, pp.179
- Ciutat, A., Widdows, J. and Readman, J.W., 2006. Influence of cockle *Cerastoderma edule* bioturbation and tidal-current cycles on resuspension of sediment and polycyclic aromatic hydrocarbons. *Marine ecology progress series*, 328, pp.51-64.
- Creek, G.A., 1960. The development of the lamellibranch *Cardium edule* L. *Proceedings of the zoological society of London*, 135(2), pp.243-260.
- Coscia, I., Robins, P.E., Porter, J.S., Malham, S.K. and Ironside, J.E., 2013. Modelled larval dispersal and measured gene flow: seascape genetics of the common cockle *Cerastoderma edule* in the southern Irish Sea. *Conservation genetics*, 14(2), pp.451-466.
- Cushing, D.H., 1975. *Marine ecology and fisheries*. Cambridge University Press, Cambridge.
- Cushing, D.H., 1990. Plankton production and year-class strength in fish populations: an update of the match/mismatch hypothesis. *Advances in marine biology*, 26, pp.249-293.
- de Montaudouin, X., Bazairi, H. and Culloty, S., 2012. Effect of trematode parasites on cockle *Cerastoderma edule* growth and condition index: a transplant experiment. *Marine ecology progress series*, 471, pp.111-121
- Desclaux, C., De Montaudouin, X. and Bachelet, G., 2002. Cockle emergence at the sediment surface: 'favourization' mechanism by digenean parasites?. *Diseases of aquatic organisms*, 52(2), pp.137-149.
- Díaz, S., Iglesias, D., Villalba, A. and Carballal, M.J., 2016. Long-term epidemiological study of disseminated neoplasia of cockles in Galicia (NW Spain): temporal patterns at individual and population levels, influence of environmental and cockle-based factors and lethality. *Journal of fish diseases*, 39(9), pp.1027-1042.

## Chapter 6

- Elliott, M., Burdon, D., Callaway, R., Franco, A., Hutchinson, T., Longshaw, M., Malham, S., Mazik, K., Otto, Z., Palmer, D. and Firmin, C., 2012. Burry Inlet cockle mortalities investigation 2009–2011 (p. 337). Final Technical Report to Environment Agency (Wales), 17 January 2012. Available online at: <http://a0768b4a8a31e106d8b0-50dc802554eb38a24458b98ff72d550b.r19.cf3.rackcdn.com/gewa0112bwap-ee.pdf>.
- Erk, M., Ivanković, D. and Strižak, Ž., 2012. Selection of target mussel tissue for application of cellular energy allocation as a physiological biomarker in native mussels *Mytilus galloprovincialis* (Lamarck, 1819). *Journal of shellfish research*, 31(1), pp.61–68.
- FAO. 2018. The State of World Fisheries and Aquaculture 2018, Rome, pp.227. Available at: <http://www.fao.org/3/i9540en/I9540EN.pdf>.
- Gallager, S.M. and Mann, R., 1986. Growth and survival of larvae of *Mercenaria mercenaria* (L.) and *Crassostrea virginica* (Gmelin) relative to broodstock conditioning and lipid content of eggs. *Aquaculture*, 56(2), pp.105–121.
- Galley, T.H., Batista, F.M., Braithwaite, R., King, J. and Beaumont, A.R., 2010. Optimisation of larval culture of the mussel *Mytilus edulis* (L.). *Aquaculture international*, 18(3), pp.315–325.
- Gam, M., Bazaïri, H., Jensen, K.T. and De Montaudouin, X., 2008. Metazoan parasites in an intermediate host population near its southern border: the common cockle (*Cerastoderma edule*) and its trematodes in a Moroccan coastal lagoon (Merja Zerga). *Journal of the marine biological association of the United Kingdom*, 88(2), pp.357–364.
- Garland, E.D. and Zimmer, C.A., 2002. Techniques for the identification of bivalve larvae. *Marine ecology progress series*, 225, pp.299–310.
- Goss-Custard, J.D. et al., 2004. When enough is not enough: shorebirds and shellfishing. *Proceedings of the royal society London*, 271(1536), pp.233–7.
- Gowen, R.J. and Stewart, B.M., 2005. The Irish Sea: nutrient status and phytoplankton. *Journal of sea research*, 54(1), pp.36–50.
- Grant, M.N., Meritt, D.W. & Kimmel, D.G., 2013. Chemical induction of settlement behaviour in larvae of the eastern oyster *Crassostrea virginica* (Gmelin). *Aquaculture*, 402–403, pp.84–91.
- Hancock, D. & Franklin, A., 1972. Seasonal changes in the condition of the edible. *British ecological society*, 9(2), pp.567–579.
- Helm, M.H. & Bourne, N., 2004. Hatchery culture of bivalves, a practical manual, FAO Fisheries Technical Paper 471, Rome, pp.203
- Honkoop, P.J.C., Van der Meer, J., Beukema, J.J. and Kwast, D., 1999. Reproductive investment in the intertidal bivalve *Macoma balthica*. *Journal of sea research*, 41(3), pp.203–212.
- Javanshir, A., 2001. Influence of infestation by *Labratrema minimus* (Bucephalidae: Digenea) on oxygen consumption of edible cockle *Cerastoderma edule* (Mollusca: Bivalvia) in laboratory conditions. *Iranian journal of fisheries sciences*, 3(1), pp.39–54.
- Jensen, K.T., 1992. Dynamics and growth of the cockle, *Cerastoderma edule*, on an intertidal mud-flat in the Danish Wadden Sea: effects of submersion time and density. *Netherlands Journal of sea research*, 28(4), pp.335–345.
- Kingston, P.F., 1974. Studies on the Reproductive Cycles of *Cardium edule* and *C. glaucum*. *Marine biology*, 28, pp.317–323.
- Kingsford, M.J., Leis, J.M., Shanks, A., Lindeman, K.C., Morgan, S.G. and Pineda, J., 2002. Sensory environments, larval abilities and local self-recruitment. *Bulletin of marine science*, 70(1), pp.309–340.
- Kurihara, H., 2008. Effects of CO<sub>2</sub>-driven ocean acidification on the early developmental stages of invertebrates. *Marine ecology progress series*, 373, pp.275–284.

## Chapter 6

- Longshaw, M. and Malham, S.K., 2013. A review of the infectious agents, parasites, pathogens and commensals of European cockles (*Cerastoderma edule* and *C. glaucum*). Journal of the marine biological association of the United Kingdom, 93(1), pp.227-247.
- Lusher, A.L., Pope, N. and Handy, R.D., 2017. Reproductive effects of endocrine disrupting chemicals, bisphenol-A and 17 $\beta$ -oestradiol, on *Cerastoderma edule* from south-west England: field study and laboratory exposure. Journal of the marine biological association of the United Kingdom, 97(2), pp.347-357.
- Lynch, S.A., Morgan, E., Carlsson, J., Mackenzie, C., Wooton, E.C., Rowley, A.F., Malham, S. and Culloty, S.C., 2014. The health status of mussels, *Mytilus* spp., in Ireland and Wales with the molecular identification of a previously undescribed haplosporidian. Journal of invertebrate pathology, 118, pp.59-65.
- Magalhães, L., Correia, S., de Montaudouin, X. and Freitas, R., 2018. Spatio-temporal variation of trematode parasites community in *Cerastoderma edule* cockles from Ria de Aveiro (Portugal). Environmental research, 164, pp.114-123
- Malham, S.K., Hutchinson, T.H. & Longshaw, M., 2012. A review of the biology of European cockles (*Cerastoderma* spp.). Journal of the marine biological association of the United Kingdom, 92(07), pp.1563–1577.
- Martínez-Castro, C. and Vázquez, E., 2012. Reproductive cycle of the cockle *Cerastoderma edule* (Linnaeus 1758) in the Ria de Vigo (Galicia, Northwest Spain). Journal of shellfish research, 31(3), pp.757-768.
- Morgan, E., O'Riordan, R.M. and Culloty, S.C., 2013. Climate change impacts on potential recruitment in an ecosystem engineer. Ecology and evolution, 3(3), pp.581-594.
- Morgan, E., Riordan, R.O., Kelly, T.C. and Culloty, S.C., 2012. Influence of disseminated neoplasia, trematode infections and gametogenesis on surfacing and mortality in the cockle *Cerastoderma edule*. Diseases of aquatic organisms, 98(1), pp.73-84.
- Ong, E.Z., Briffa, M., Moens, T. and Van Colen, C., 2017. Physiological responses to ocean acidification and warming synergistically reduce condition of the common cockle *Cerastoderma edule*. Marine environmental research, 130, pp.38-47.
- Orton, J.H., 1926. On the growth rate of *Cardium edule*, part 1. Experimental observations. Journal of the marine biological association of the United Kingdom, 14, pp.239-280.
- Orton, J.H., 1933. Summer mortality of cockles on some Lancashire and Cheshire Dee beds in 1933. Nature, 132(3330), p.314.
- Pina, S., Barandela, T., Santos, M.J., Russell-Pinto, F. and Rodrigues, P., 2009. Identification and description of *Bucephalus minimus* (Digenea: Bucephalidae) life cycle in Portugal: morphological, histopathological, and molecular data. Journal of parasitology, 95(2), pp.353-359.
- Pingree, R.D., Holligan, P.M., Mardell, G.T. and Head, R.N., 1976. The influence of physical stability on spring, summer and autumn phytoplankton blooms in the Celtic Sea. Journal of the marine biological association of the United Kingdom, 56(4), pp.845-873.
- Pronker, A.E., Nevejan, N.M., Peene, F., Geijssen, P. and Sorgeloos, P., 2008. Hatchery broodstock conditioning of the blue mussel *Mytilus edulis* (Linnaeus 1758). Part I. Impact of different micro-algae mixtures on broodstock performance. Aquaculture international, 16(4), pp.297-307.
- Pronker, A.E., Peene, F., Donner, S., Wijnhoven, S., Geijssen, P., Bossier, P. and Nevejan, N.M., 2015. Hatchery cultivation of the common cockle (*Cerastoderma edule* L.): from conditioning to grow-out. Aquaculture research, 46(2), pp.302-312.
- Ramilo, A., Abollo, E., Villalba, A. and Carballal, M.J., 2018. A Minchinia mercenariae-like parasite infects cockles *Cerastoderma edule* in Galicia (NW Spain). Journal of fish diseases, 41(1), pp.41-48.
- Reis Batista, I., Kamermans, P., Verdegem, M.C.J. and Smaal, A.C., 2014. Growth and fatty acid composition of juvenile *Cerastoderma edule* (L.) fed live microalgae diets with different fatty acid profiles. Aquaculture nutrition, 20(2), pp.132-142.

## Chapter 6

- Robledo, J.A.F., Marquis, N.D., Countway, P.D., Record, N.R., Irish, E.L., Schuldt, M.M., Kingston, S.E., Bishop, T.J., Messerman, N.A. and Bowden, T.J., 2018. Pathogens of marine bivalves in Maine (USA): A historical perspective. *Aquaculture*.
- Rueda, J.L., Smaal, A.C. and Scholten, H., 2005. A growth model of the cockle (*Cerastoderma edule* L.) tested in the Oosterschelde estuary (The Netherlands). *Journal of sea research*, 54(4), pp.276-298.
- Seed, R. & Brown, R., 1977. A comparison of reproductive cycles of *Modiolus modiolus* (L.), *Cerastoderma* (= *Cardium*) *edule* (L.), and *Mytilus edulis* (L.) in Strangford Lough, Northern Ireland. *Oecologia*, 30, pp.173–188.
- Thebault, A., 2001. Epidémiologie dans le cas de mortalités anormales de coquillages: exemple des coques du Croisic (Doctoral dissertation, Thesis, University of Medicine of Créteil).
- Trindade, A.B., Pires, P.J., Teixeira, S., Ferreira, A.R., Machado, D., Anjos, C.M., Mendes, S.L., Matias, D., Joaquim, S. and Baptista, T.M., 2019. Study of the reproductive cycle of cockle (*Cerastoderma edule*, Linnaeus, 1758), from Lagoa de Óbidos, Leiria, Portugal. *Front. Mar. Sci. Conference Abstract: IMMR'18, International Meeting on Marine Research 2018*. doi: 10.3389/conf.FMARS.2018.06.00154.
- Tyler-Walters, H., 2007. *Cerastoderma edule* Common cockle. In Tyler-Walters H. and Hiscock K. (eds) *Marine Life Information Network: Biology and Sensitivity Key Information Reviews*, [on-line]. Plymouth: Marine biological association of the United Kingdom. Available from: <https://www.marlin.ac.uk/species/detail/1384>
- Utting, S.D. and Millican, P.F., 1997. Techniques for the hatchery conditioning of bivalve broodstocks and the subsequent effect on egg quality and larval viability. *Aquaculture*, 155(1-4), pp.45-54.
- Wenne, R. and Polak, L., 1992. Lipid storage strategy in the clam *Macoma* (Bivalvia). In *Proceedings of the 12th Baltic Marine Biologists Symposium* (pp. 179-183).
- Woolmer, A., Fitzgerald, A., Woo, J., and Wootton, E., 2013. Atypical Cockle Mortality in England & Wales. Review of National Cockle Mortality Issues and Options for Fishery Management in Kent and Essex IFCA, UK.
- Zhang, H., Wang, H., Chen, H., Wang, M., Zhou, Z., Qiu, L., Wang, L. and Song, L., 2019. The transcriptional response of the Pacific oyster *Crassostrea gigas* under simultaneous bacterial and heat stresses. *Developmental & comparative immunology*.

## Appendix

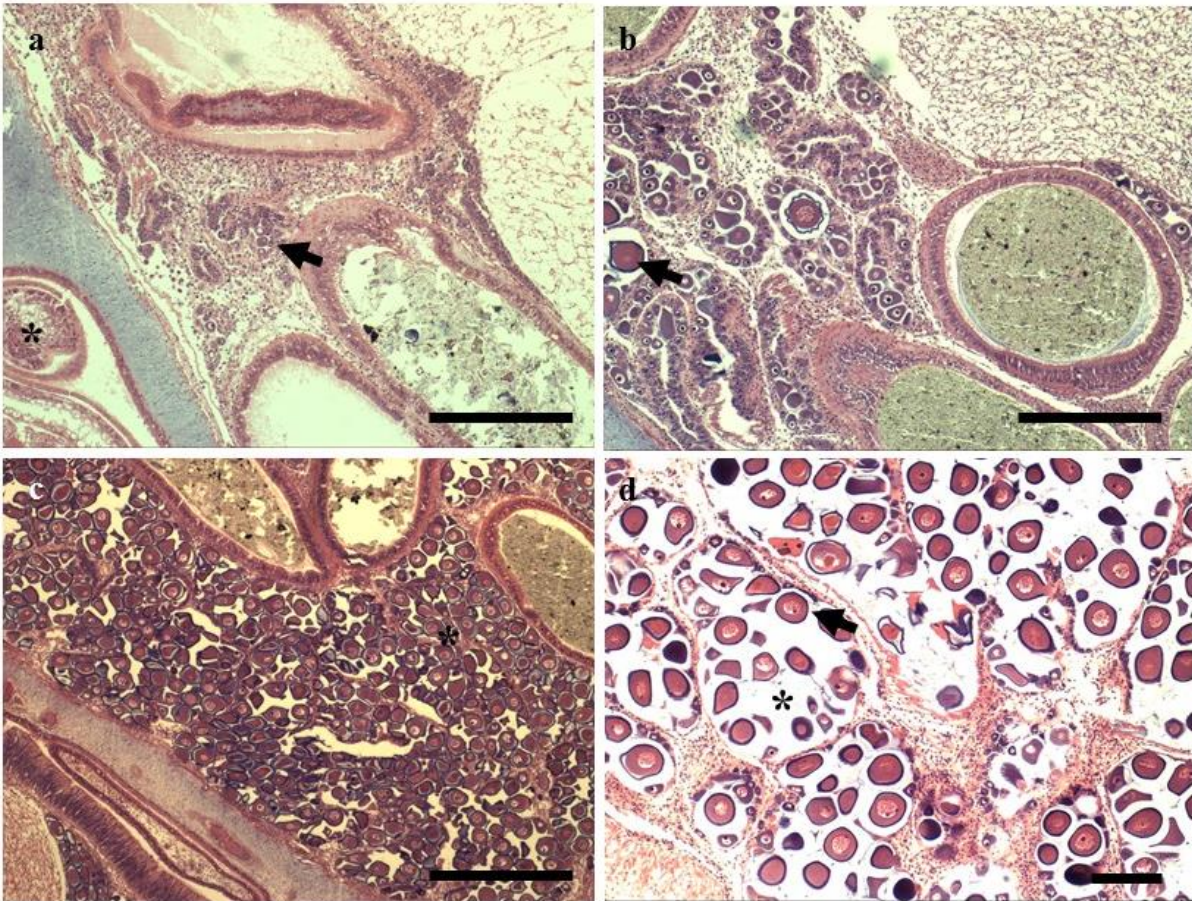
### A.1 *Maturation classification*

Sex and the gonad maturation stage of the cockle was recorded during the screening process from those cockles displaying clear evidence of gonad structure and were easily identifiable. Gonad maturation stages were scaled from 1-7, based on existing classification schemes (Kingston 1974; Newell and Bayne, 1990; Seed and Brown, 1997; Drummond et al., 2006; Morgan et al., 2013) and modified to fit with our samples and observations (Table A1, Fig. A1 & A2). See Morgan et al., 2013 for further examples of the development stages of male and female gonads.

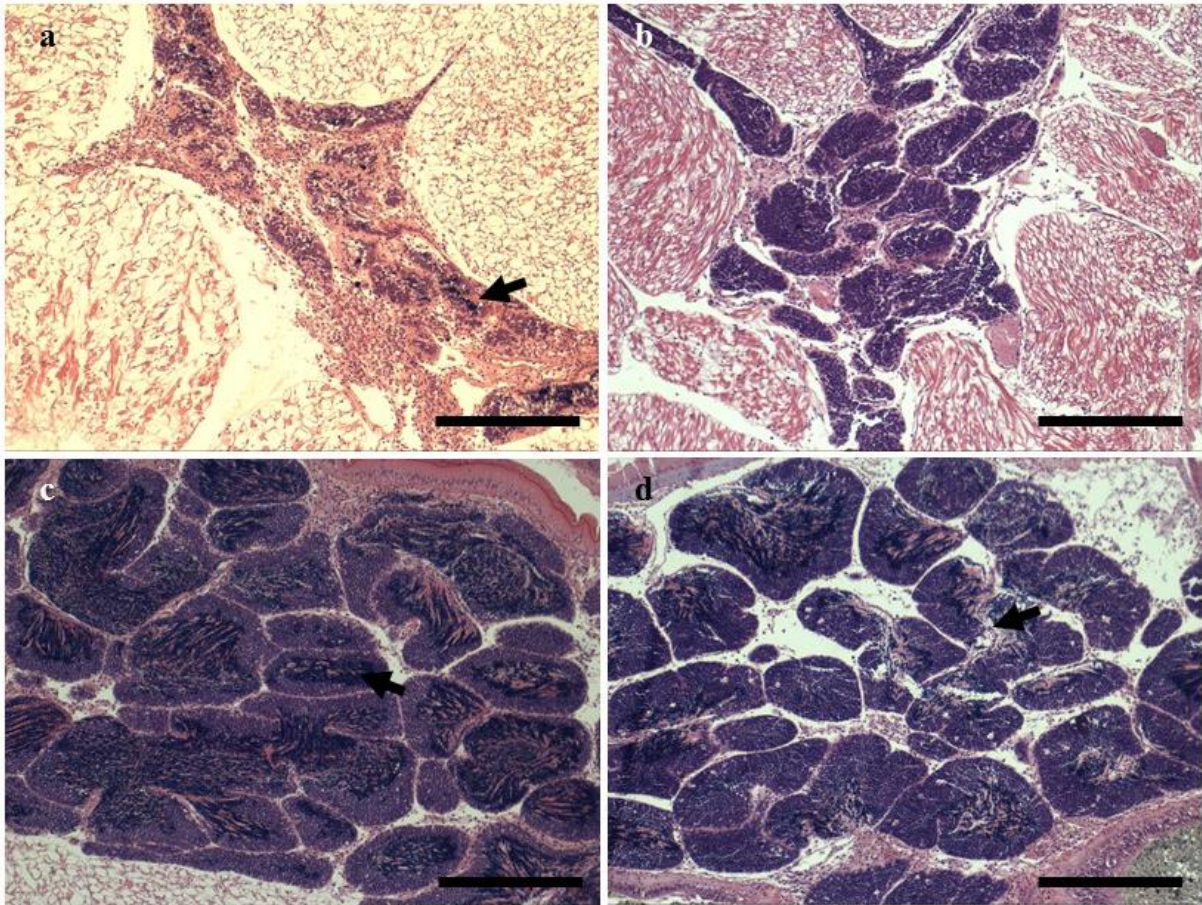
**Table A1.** Maturation classification stages of the gonads from for both sexes of *Cerastoderma edule*.

Stage	Description
1.	Resting or spent: no gametes present or undifferentiated. Distinguishing between male and female cockles not possible
2.	Gametogenesis: Gonads begin to develop with small numbers of oocytes and spermatozoa visible. Distinguishing between ovary and teste possible. No ripe gametes present (Fig. A4.1a & A4.2a)
3.	Developmental: Clear oocytes and spermatozoa present in gonads. Gametes ripen and fill up to half of the gonad (Fig. A4.1b & A4.2b)
4.	Ripe Gonads: Gonads full of ripe gametes. Sexing easily distinguishable (Fig. A4.1c & A4.2c)
5.	Spawning: Reduction in gamete density showing clear signs of spawning activity. Gonad up to half-empty. Quantity of fresh gametes low in comparison to stages 3 & 4. (Fig. A4.1d & A4.2d).
6.	Post-spawning or Spent – largely empty gonads with some residual gametes present facilitating identification between males and females
7.	Spent gonads but showing signs of secondary development



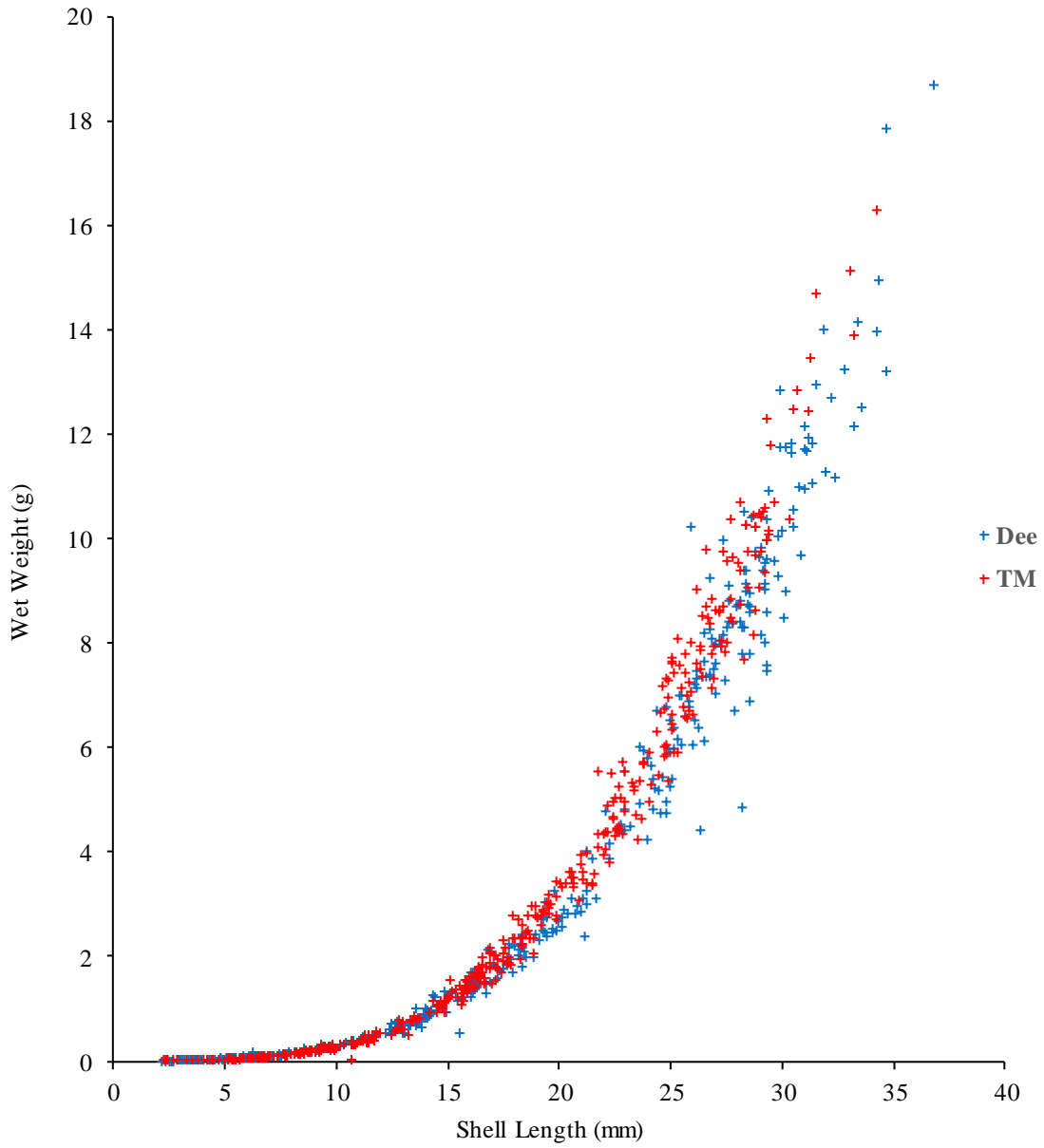


**Figure A1.** Histological sections of female gonad maturation stages (Table A4.1) of *Cerastoderma edule* (sections stained with haematoxylin and eosin, H&E): (a) Stage 2 with developing ovary (arrow); (b) stage 3 with low numbers of ripe gametes (arrow); (c) stage 4, gonad full of ripe eggs gonad; (d) stage 5, eggs ripen (arrow) and spawning commenced with reduction in density (\*). Scale bars (a, b & c) = 500  $\mu\text{m}$ ; (d) = 100  $\mu\text{m}$ .



**Figure A2.** Histological sections of the male gonad showing the maturation stages (Table A4.1) of *Cerastoderma edule* (sections stained with haematoxylin and eosin, H&E): (a) stage 2 with developing spermatozoa (arrow); (b) stage 3 gonad begins to swell with developing spermatozoa; (c) stage 4, gonad full of ripe gametes with sperm visible inside (arrow); (d) stage 5, spawning commenced with reduction in density (arrow) and less sperm within the gonad. All scale bars = 500  $\mu\text{m}$ .

Appendix



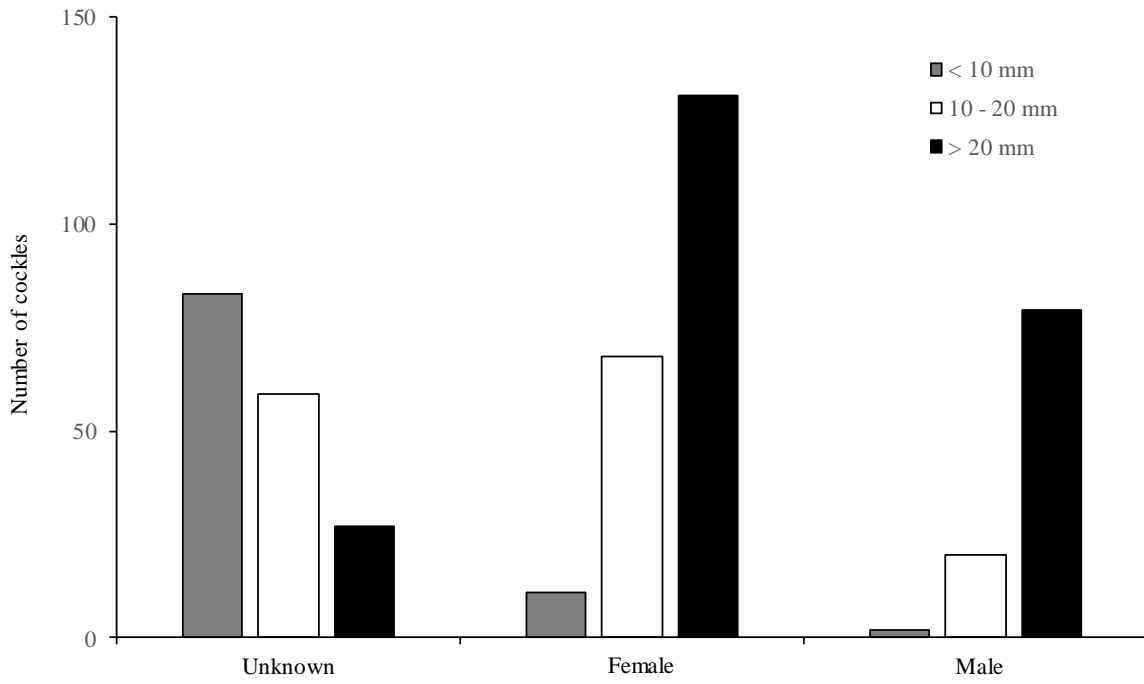
**Figure A3.** Relationship between the shell length and wet weight (including shell) of all samples of *Cerastoderma edule* collected from the Dee estuary and Traeth Melynog, North Wales between 2014 - 2015.

Appendix

**Table A2.** Number of cockles for each sampling period per size class (<10 mm; 10-20 mm and >20 mm) that were used in the analysis. Size classes divided into the known or unknown sex of the individual cockle.

Site	Bed and season	<10 mm			<10 Total	10 – 20 mm			>10<20 Total	>20 mm			>20 Total
		unknown	Female	Male		unknown	Female	Male		unknown	Female	Male	
Dec	<b>DA (totals)</b>	<b>20</b>	<b>5</b>	<b>1</b>	<b>26</b>	<b>9</b>	<b>14</b>	<b>8</b>	<b>31</b>	<b>1</b>	<b>44</b>	<b>18</b>	<b>63</b>
	Autumn	5	2	1	8		6	2	8		12	2	14
	Winter	3			3	3	3	4	10		10	7	17
	Spring	4	2		6	3	3	1	7	1	11	5	17
	Summer	8	1		9	3	2	1	6		11	4	15
	<b>DB (totals)</b>	<b>22</b>	<b>3</b>	<b>1</b>	<b>26</b>	<b>12</b>	<b>18</b>	<b>5</b>	<b>35</b>	<b>2</b>	<b>28</b>	<b>29</b>	<b>59</b>
	Autumn	7	2	1	10	4	5	1	10		4	6	10
	Winter		1		1	3	5	1	9	1	10	9	20
	Spring	8			8		5	2	7		7	8	15
	Summer	7			7	5	3	1	9	1	7	6	14
TM	<b>TMA (totals)</b>	<b>22</b>	<b>3</b>		<b>25</b>	<b>16</b>	<b>20</b>	<b>3</b>	<b>39</b>	<b>9</b>	<b>32</b>	<b>15</b>	<b>56</b>
	Autumn	9			9	6	4		10	4	6	1	11
	Winter	4			4	4	8		12	1	8	5	14
	Spring		3		3	1	4	3	8		10	9	19
	Summer	9			9	5	4		9	4	8		12
	<b>TMB (totals)</b>	<b>19</b>			<b>19</b>	<b>22</b>	<b>16</b>	<b>4</b>	<b>42</b>	<b>15</b>	<b>27</b>	<b>17</b>	<b>59</b>
	Autumn	8			8	8	2		10	7	3	2	12
	Winter	2			2	7	5		12	3	10	3	16
	Spring	3			3		7	4	11		7	9	16
	Summer	6			6	7	2		9	5	7	3	15

Appendix



**Figure A4.** Breakdown of the number of individual cockles per size class and for each sex that were used in the analysis ( $n= 480$ ).