

# RAEPoint

## User's Guide



# RAEPoint User's Guide

## Special Servicing Note

If the instrument needs to be serviced, contact either:  
The RAE Systems distributor from whom the instrument was purchased; they will return the instrument on your behalf.

or

The RAE Systems Technical Service Department. Before returning the instrument for service or repair, obtain a Returned Material Authorization (RMA) number for proper tracking of your equipment. This number needs to be on all documentation and posted on the outside of the box in which the instrument is returned for service or upgrade. Packages without RMA Numbers will be refused at the factory.



© Copyright 2014 RAE Systems by Honeywell.

# RAEPoint User's Guide

## Contents

|   |    |
|---|----|
| WARNINGS.....                                 | 1  |
| 1 General Information .....                   | 2  |
| 2 Proper Product Disposal At End Of Life..... | 3  |
| 3 FCC Part 15 Statement .....                 | 3  |
| 4 Applications.....                           | 4  |
| 5 RAEPoint Specifications .....               | 7  |
| 6 Operation .....                             | 8  |
| 7 Physical Description .....                  | 9  |
| 8 Physical Dimensions .....                   | 9  |
| 9 Installation And Access Instructions .....  | 10 |
| 9.1 Mounting .....                            | 10 |
| 9.2 Instrument Disassembly .....              | 12 |
| 9.3 Instrument Reassembly .....               | 13 |
| 10 RAEPoint Wiring .....                      | 14 |
| 11 RAEPoint Wiring Procedure .....            | 15 |
| 12 DC Control Wiring.....                     | 16 |
| 13 Switch Settings .....                      | 17 |
| 13.1 Pan ID (SW1) And Channel (SW2) .....     | 17 |
| 13.2 Mode Switch (SW3) .....                  | 18 |
| 13.3 Jumper JP1.....                          | 19 |
| 14 Earth Grounding Instructions .....         | 20 |
| 14.1 External Earth Grounding.....            | 20 |
| 14.2 Internal Earth Grounding.....            | 20 |
| 14.3 Finished Grounding Wires .....           | 21 |
| 15 Display/User Interface.....                | 22 |
| 16 Alarm Signal Summary .....                 | 22 |
| 16.1 RAEPoint Host .....                      | 23 |
| 16.2 RAEPoint Remote .....                    | 24 |
| 16.3 RAEPoint Router.....                     | 25 |
| 17 Appendix A: Controlled Section .....       | 26 |
| 17.1 Scope .....                              | 26 |
| 17.2 Responsibility .....                     | 26 |
| 17.3 Contents.....                            | 26 |
| 18 Technical Support.....                     | 33 |
| 19 RAE Systems Contacts.....                  | 33 |

## RAEPoint User's Guide

### Read Before Operating

This manual must be carefully read by all individuals who have or will have the responsibility of using, maintaining, or servicing this product. The product will perform as designed only if it is used, maintained, and serviced in accordance with the manufacturer's instructions. The user should understand how to set the correct parameters and interpret the obtained results.

#### **CAUTION!**

To reduce the risk of electric shock, turn the power off before opening this instrument or performing service. Never operate the instrument when the instrument is open. Use and service this product only in an area known to be non-hazardous.

#### **WARNINGS**

For safety reasons, this equipment must be operated and serviced by qualified personnel only. Read and understand instruction manual completely before operating or servicing.

#### **AVERTISSEMENT**

Pour des raisons de sécurité, cet équipement doit être utilisé, entretenu et réparé uniquement par un personnel qualifié. Étudier le manuel d'instructions en entier avant d'utiliser, d'entretenir ou de réparer l'équipement.

# RAEPoint User's Guide

## 1 General Information

RAEPoint is an explosion-proof wireless device that both extends the range and enables remote relay functionality across a wireless mesh network. As part of a wireless mesh network, the RAEPoint communicates with wireless detectors and controllers and can direct any of its five internal relays to trigger audible and visible alarms. Remote alarm notifications are critical for many applications where local device alarms are simply not visible enough or loud enough to alert a wide area. RAEPoint relay settings can be fully configured wirelessly via the system controller. RAEPoint can also be configured as a wireless host, and communicate directly with detectors, providing a localized alarm notification solution that does not require a controller.

## Key Features

- Five internal SPDT relays (except in RAEPoint router)
- Wireless transmission distance of 1000 ft (300m) line-of-sight. Range can be extended by using wireless routers.
- Class 1, Division 1, and IECEx/ATEX Zone 1 hazardous area certification
- Explosion-proof enclosure for hazardous environment applications
- LEDs indicate status

## Applications

- Oil and gas exploration
- Refineries and petrochemical plants
- Fenceline monitoring

## 2 Proper Product Disposal At End Of Life



The Waste Electrical and Electronic Equipment (WEEE) directive (2002/96/EC) is intended to promote recycling of electrical and electronic equipment and their components at end of life. This symbol (crossed-out wheeled bin) indicates separate collection of waste electrical and electronic equipment in the EU countries.

## 3 FCC Part 15 Statement

This device complies with Part 15 of the FCC rules. Operation is subject to the following two conditions: (1) This device may not cause harmful interference, and (2) this device must accept any interference received, including interference that may cause undesired operation.

# RAEPoint User's Guide

## 4 Applications

The RAEPoint can be ordered as a stand-alone wireless unit, or as part of an integrated Wireless Alarm Bar complete with 2 strobes and horn (Wireless Alarm Bar). Each RAEPoint can be configured as a Router, Remote, or Host on a wireless mesh network.

**Note:** The Wireless Alarm Bars (AC and DC versions) used as examples in this manual do not conform to the same certifications of the RAEPoint. Refer to the corresponding Wireless Alarm Bar manuals for product specific specifications.

### RAEPoint Router

A stand-alone, DC-powered, explosion-proof unit that acts as a permanent wireless router for mesh network systems. Includes aluminum enclosure with LED status indicators and an integrated wireless mesh radio.

### RAEPoint Remote & RAEPoint Host

Stand-alone relay units include aluminum enclosure with LED status indicators, an integrated wireless mesh radio, and five integrated relays.

### RAEPoint Remote Wireless Alarm Bar & RAEPoint Host Wireless Alarm Bar

Wireless alarm bar units include the RAEPoint fully integrated with 2 certified xenon strobes and a certified 110dB horn.

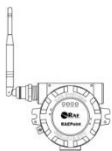

**RAEPoint**

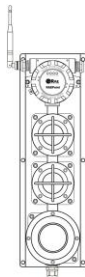

**RAEPoint DC-Powered Wireless Alarm Bar**

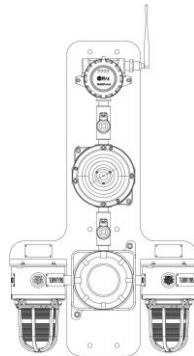

**RAEPoint AC-Powered Wireless Alarm Bar**

# RAEPoint User's Guide

## Flexibility

RAEPoint can be used in large or small systems, and the network can be expanded or units removed, depending on the facility or facilities being monitored.

## Simple configurations that use MeshGuard sensors and a RAEPoint Wireless Alarm Bar host

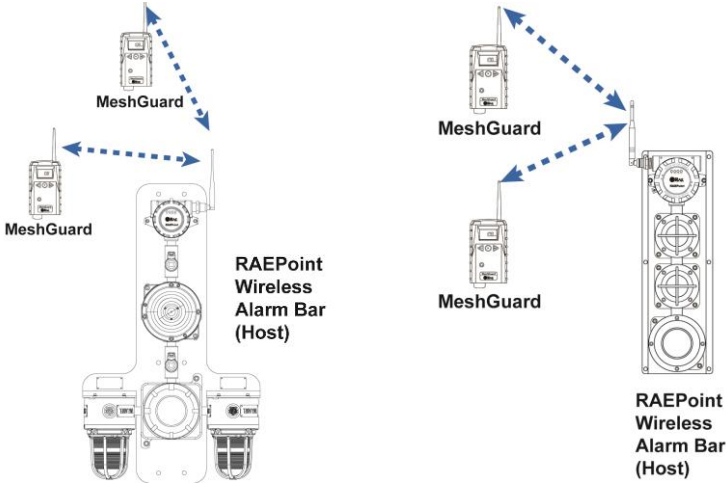

## Full network, including externally controlled devices (AC-Powered Alarm Bar configured as Remote)

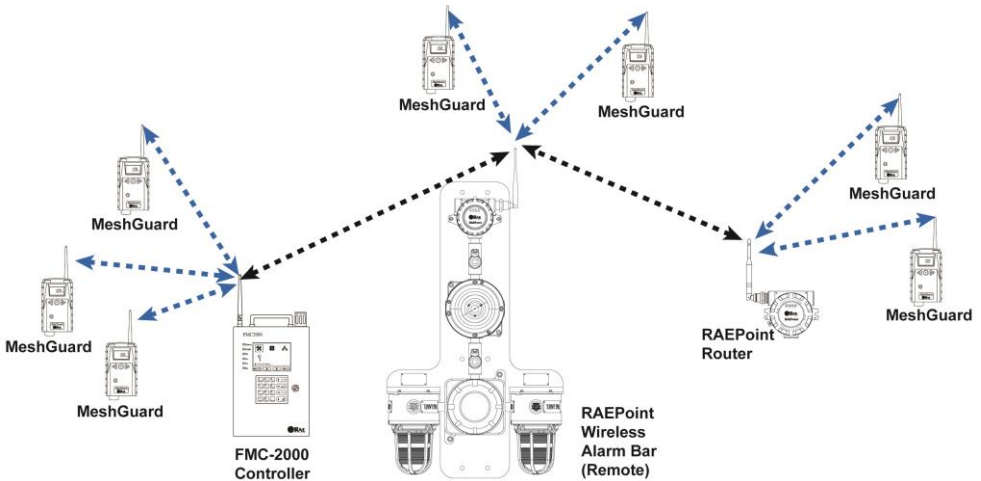



# RAEPoint User's Guide

Full network, including externally controlled devices (DC-Powered Alarm Bar with RAEPoint configured as Remote)

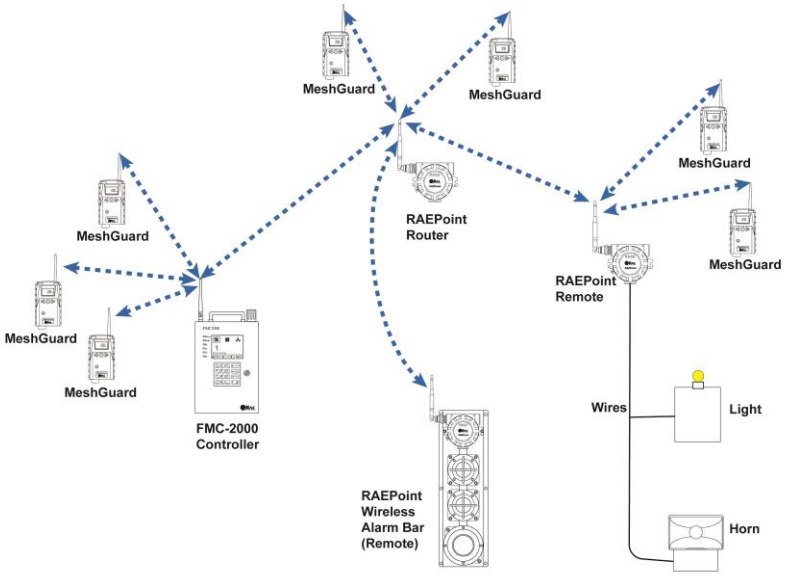

## RAEPoint User's Guide

### 5 RAEPoint Specifications

This table covers RAEPoint only.

|   |  |
|---|--|
| Input Power                             | Input Power Limit: 2.4W<br>$V_{input}$ : 12-28VDC  |
| Output                                  | Five 3-level programmable alarm relays (30 VDC, 2A), dry contact<br>Resistive load Max: 6A@24VDC or 6A@250VAC<br>Inductive load Max: 2A@24VDC or 3A@250VAC |
| IP Rating                               | IP-65  |
| Mechanical Interface                    | 3/4" NPT Female  |
| Installation                            | 2" pipe-holding or wall mounting   |
| <b>Operation Environment Parameters</b> |  |
| Temperature                             | -20° C to +55° C (-4° F to 131° F)   |
| Humidity                                | 0 to 95% relative humidity, non-condensing   |
| Pressure                                | 90 to 110kPa   |
| <b>Display</b>                          |  |
| Display                                 | 4 LEDs (Network, Alarm, Communication, Mode)   |
| <b>Physical Parameters</b>              |  |
| Dimensions, L x W x H                   | 257 x 201 x 107 mm (10.1" x 7.9" x 4.2")   |
| Material                                | Alumina  |
| Weight                                  | 3.5 kg (7.7 lbs)   |

Specifications subject to change.

# RAEPoint User's Guide

## Brazil Radio Specifications

**Radio model:** RM900A

**Frequency range:** Within 902 to 907.5 MHz and 915 to 928 MHz, use IEEE 802.15.4 channel 1, 6, 7, 8, 9 and 10

**Modulation:** 802.15.4 DSSS BPSK

**RF power(Tx):** 20dBm

**Data rate:** 40kbps

**Radio model:** RM2400A

**Frequency range:** 2.400 to 2.4835GHz



**Modulation:** 802.15.4 DSSS BPSK

**RF power(Tx):** 20dBm

**Data rate:** 250kbps

## RAEPoint Hazardous Location Classification

This table includes Hazardous Location information for RAEPoint only. The Wireless Alarm Bars (AC and DC versions) used as examples in this manual do not conform to the same certifications of the RAEPoint. Refer to the corresponding Wireless Alarm Bar manuals for product specific specifications.

| IECEX                 | ATEX   | North America                   |
|-----------------------|--|---------------------------------|
| IECEX SIR<br>12.0027X | Sira 12ATEX 1085X  |                                 |
| Ex d ia IIC T6,<br>Gb |  0575  II 2G,<br>Ex d ia IIC T6 Gb | Cl.I Div 1, Group<br>A,B,C,D T6 |

Temperature range:  $-20^{\circ} \text{C} \leq T_{\text{amb}} \leq 55^{\circ} \text{C}$

## 6 Operation

**Note:** Prior to factory shipment, the RAEPoint is tested. However, the instrument should be tested after installation.

# RAEPoint User's Guide

## 7 Physical Description

The RAEPoint can be easily installed and integrated with various control systems. It is designed with flexible pipe-holding/wall-mounting options and standard connection terminals.

## 8 Physical Dimensions

The physical dimensions are as follows:

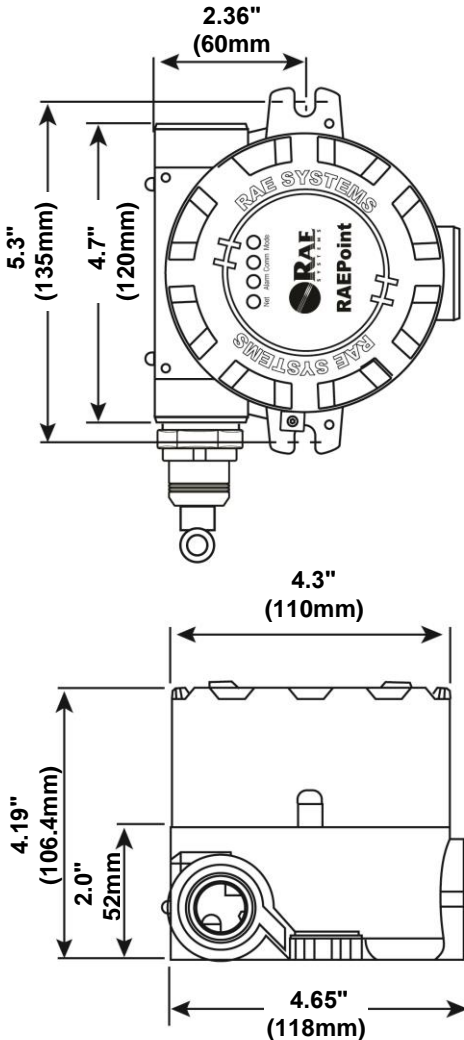

## 9 Installation And Access Instructions

**Note:** If the RAEPoint is integrated into a Wireless Alarm Bar, follow the installation and access instructions in its Installation Guide.

### 9.1 Mounting

First, decide where the transmitter will be mounted. (Refer to installation drawing, below.) Drill two holes in mounting surface, with the center of the holes 5.25" (135 mm) apart.

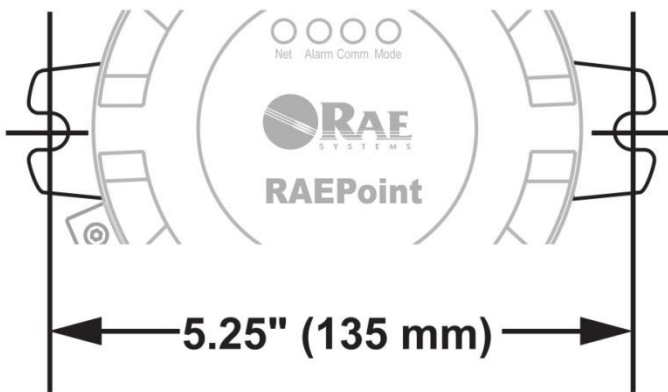

# RAEPoint User's Guide

Besides being mounted to a wall, RAEPoint can be mounted on a pipe.

**Note:** When installing the RAEPoint, make sure the antenna is installed in the left or right inlet (not the one on the bottom).

**Wall**

**Pole**

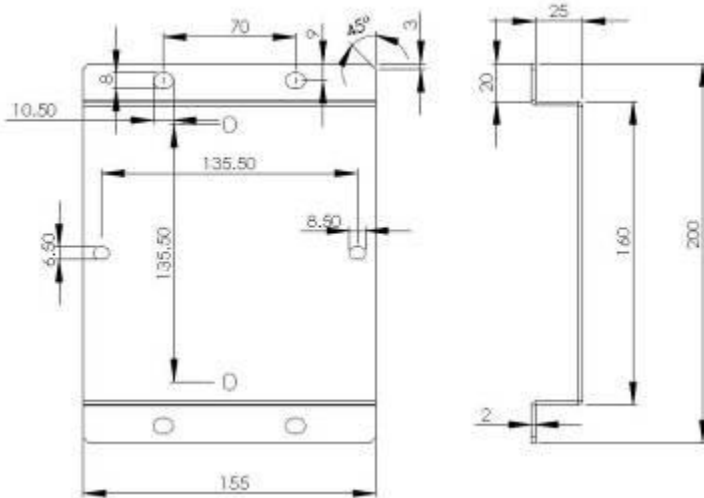
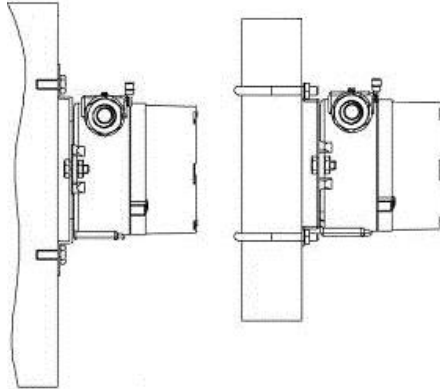

# RAEPoint User's Guide

## 9.2 Instrument Disassembly



Prior to service: Make sure power is OFF. Observe all Hazardous Location Safety procedures.

1. Loosen the hex locking screw on the housing lid.



2. Unscrew the housing lid by rotating it counterclockwise.

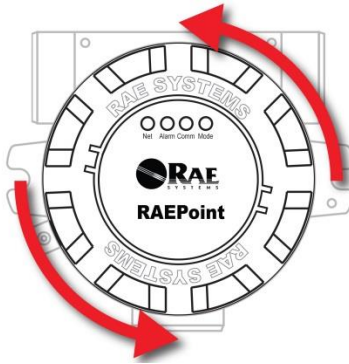

3. Press in on the clips on both sides of the display, and then lift out the circuit boards.

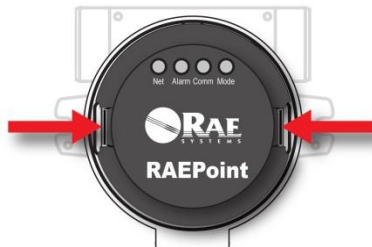

4. Turn the circuit boards over to access the switches and wiring points. Be careful not to damage the antenna wire between





# RAEPoint User's Guide

## 10 RAEPoint Wiring

The two terminal blocks in the RAEPoint accept 12AWG to 24AWG wire. One terminal block is for DC power, and the other is for relay connections. **Note:** Refer to the RAEPoint Wireless Alarm Bar's User's Guide for information on connecting the Wireless Alarm Bar.

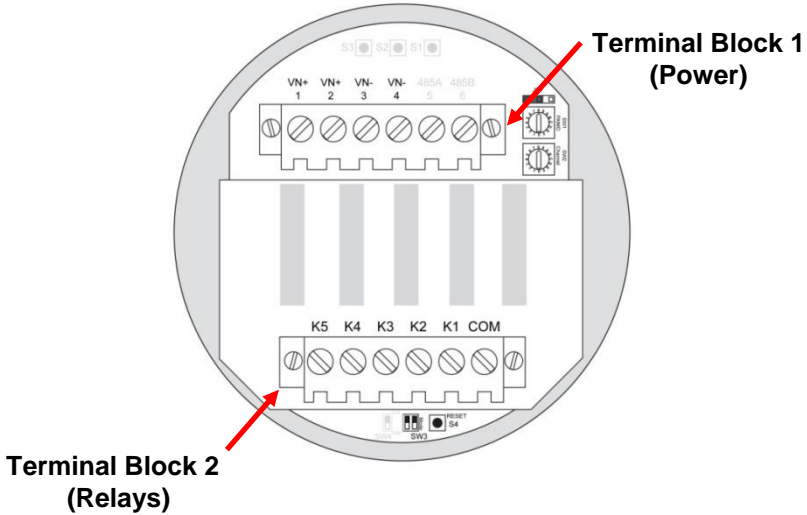

### IMPORTANT!

Read this before wiring a RAEPoint to control external customized loads.

1. Before wiring a RAEPoint to control external devices, consult the datasheet that applies to the RAEPoint's relays:  
[http://www3.panasonic.biz/ac/e/control/relay/cautions\\_use/index.jsp#ANCHOR3](http://www3.panasonic.biz/ac/e/control/relay/cautions_use/index.jsp#ANCHOR3)
2. Some non-resistive loads, such as motors, horns, or strobes, may present high inrush current, causing relay contact degradation/welding even they are within the relays' rating. A simple solution is to place an NTC thermistor (for example, model B57236S0509M0\*\* from EPCOS) in series between the relay and the load, to limit inrush current.

**Note:** A RAEPoint that is factory-configured as a router does not contain relays.

# RAEPoint User's Guide

## 11 RAEPoint Wiring Procedure

**Note:** The following section is for wiring a stand-alone RAEPoint. If you are wiring a RAEPoint Wireless Alarm Bar, refer to the RAEPoint Wireless Alarm Bar Installation Guide.

1. Inside the housing bottom, two green terminal block plugs are inserted into the terminal blocks on the PC boards.

The terminal block plugs accept 12 AWG to 24 AWG wire.

**Note:** On the RAEPoint Wireless Alarm Bar, wiring from the Relay outputs and downline power are already complete. Only Power and Ground (earth) connections need to be made. See “Earth Grounding Instructions,” page 20, for information on proper grounding.

2. Route the wires through the RAEPoint's wire hole(s) and connect wires to the corresponding pin numbers of the terminal blocks:

| Terminal | Terminal Definition                   | Terminal | No. |
|----------|---------------------------------------|----------|-----|
| Block 1  | Positive DC power supply for RAEPoint | VN+      | 1   |
|          | Positive DC power for downline units  | VN+      | 2   |
|          | Negative DC power supply for RAEPoint | VN-      | 3   |
|          | Negative DC power for downline units  | VN-      | 4   |
| Block 2  | Relay Output 5                        | K5       | K5  |
|          | Relay Output 4                        | K4       | K4  |
|          | Relay Output 3                        | K3       | K3  |
|          | Relay Output 2                        | K2       | K2  |
|          | Relay Output 1                        | K1       | K1  |
|          | Relay Common                          | COM      | COM |

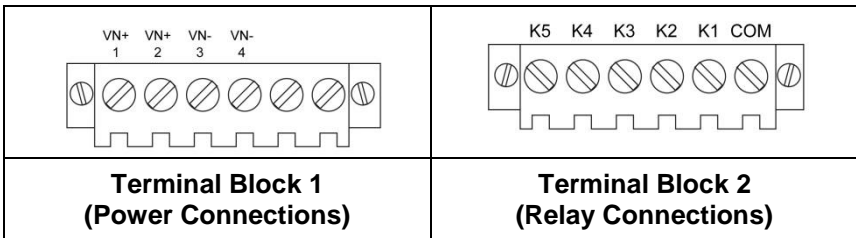

# RAEPoint User's Guide

## 12 DC Control Wiring

When wiring the RAEPoint's relays to external devices, the resistance of the wiring may be sufficient to cause significant voltage drop, particularly in long wires. In order to compensate for this, you must calculate the resistance and compensate accordingly.

The table below gives approximate values for resistance by wire gauge (AWG). After calculating and compensating for voltage drop, check the system to ensure that all equipment is receiving sufficient voltage.

### Wire Gauge and DC resistance values (in ohms)

| AWG gauge | Ohms per 1000 ft. | Ohms per km |
|-----------|-------------------|-------------|
| 12        | 1.588             | 5.20864     |
| 13        | 2.003             | 6.56984     |
| 14        | 2.525             | 8.282       |
| 15        | 3.184             | 10.44352    |
| 16        | 4.016             | 13.17248    |
| 17        | 5.064             | 16.60992    |
| 18        | 6.385             | 20.9428     |
| 19        | 8.051             | 26.40728    |
| 20        | 10.15             | 33.292      |
| 21        | 12.8              | 41.984      |
| 22        | 16.14             | 52.9392     |
| 23        | 20.36             | 66.7808     |
| 24        | 25.67             | 84.1976     |

Voltage Loss = Amperes x Wire Resistance per 1,000 feet x Distance in thousands of feet x 2 Wires

- or -

Voltage Loss = Amperes x Wire Resistance per kilometer x Distance in kilometers x 2 Wires

# RAEPoint User's Guide

## 13 Switch Settings

Configuration requires setting the two hexadecimal rotary-encoder switches that govern Pan ID and Channel, located inside the RAEPoint.

### 13.1 Pan ID (SW1) And Channel (SW2)

Make sure all units in the network, including an FMC2000 controller and any monitors, have the same Pan ID number and channel in order to communicate within the network. If you change the Pan ID number or Channel on the FMC2000, check the other units in the network, as well as the RAEPoint, to ensure they match.

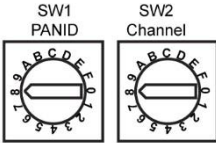

**Use a small-blade screwdriver to turn each rotary encoder to the proper value.**

The following chart shows settings for the two encoders:

| SW1           | 0       | 1              | 2   | 3   | 4   | 5   | 6   | 7       | 8    | 9    | A    | B    | C    | D    | E    | F    |
|---------------|---------|----------------|-----|-----|-----|-----|-----|---------|------|------|------|------|------|------|------|------|
| PAN ID        | 999     | 998            | 997 | 996 | 995 | 994 | 993 | 992     | 991  | 990  | 989  | 988  | 987  | 986  | 985  | 984  |
|               |         |                |     |     |     |     |     |         |      |      |      |      |      |      |      |      |
| SW2           | 0       | 1              | 2   | 3   | 4   | 5   | 6   | 7       | 8    | 9    | A    | B    | C    | D    | E    | F    |
| Channel (ISM) | Ch0     | Ch1            | Ch3 | Ch5 | Ch6 | Ch7 | Ch8 | Ch10    | Ch15 | Ch16 | Ch17 | Ch18 | Ch19 | Ch20 | Ch25 | Ch26 |
|               | 868 MHz | 902 to 928 MHz |     |     |     |     |     | 2.4 GHz |      |      |      |      |      |      |      |      |

### IMPORTANT!

Available channels vary by the internal wireless modem's frequency.

The channel can only be set to one that is available for the wireless modem frequency of your RAEPoint. For example, a RAEPoint with a 2.4 GHz modem can only use channels shown (15, 16, 17, 18, 19, 20, 25, 26).

**Note:** After you change the settings on the rotary encoders, press the Reset button (labeled S4).

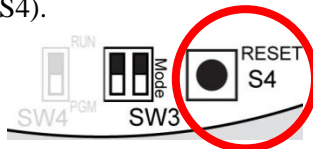

# RAEPoint User's Guide

## 13.2 Mode Switch (SW3)

Two DIP switches, labeled SW3, can be used to change the RAEPoint's mode of operation (Host, Remote, or Router). The RAEPoint's mode was set at the factory, but if you need to reconfigure it, set the switches as follows:

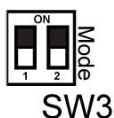

| Switch 1 | Switch 2 | Mode             |
|----------|----------|------------------|
| On       | On       | RAEPoint Host    |
| On       | Off      | RAEPoint Remote  |
| Off      | On       | RAEPoint Router  |
| Off      | Off      | Factory Setting* |

Factory settings are indicated by the RAEPoint's serial number:

- F081 RAEPoint Remote
- F082 RAEPoint Router
- F083 RAEPoint Host

**Note:** After you change the settings on the two DIP switches, press the Reset button (labeled S4).

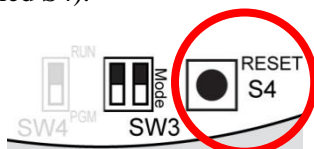

# RAEPoint User's Guide

## 13.3 Jumper JP1

The jumper labeled JP1 has no effect on operation, so leave it in place, as shown:

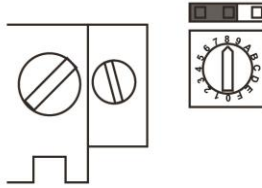

### **Important!**

Once the system is operational, test the functionality of all connected relays.

## 14 Earth Grounding Instructions

### 14.1 External Earth Grounding

Fasten the crimped ground wire with hardware as illustrated below. The wire should have a minimum cross-section area of  $4\text{mm}^2$  for its conductor.

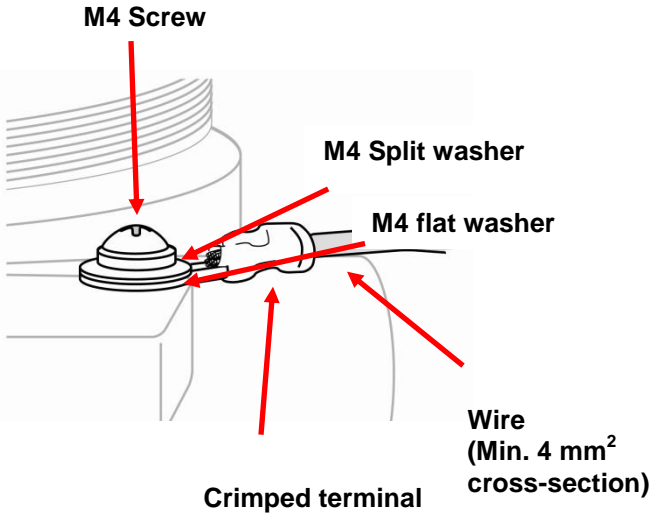

### 14.2 Internal Earth Grounding

Use the same hardware as shown in the illustration of external earth grounding. The wire should be no less than the size of the power lines. Signal grounding can connect to a cable's shielding layer if shielded cable is used. If a separate wire is used for grounding, its cross section should be greater than that of the power line.

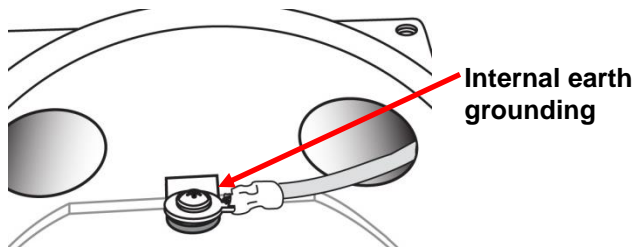

# RAEPoint User's Guide

## 14.3 Finished Grounding Wires

Internal and external grounding are shown here, as well as an alternate external grounding point. Always follow local electrical guidelines.

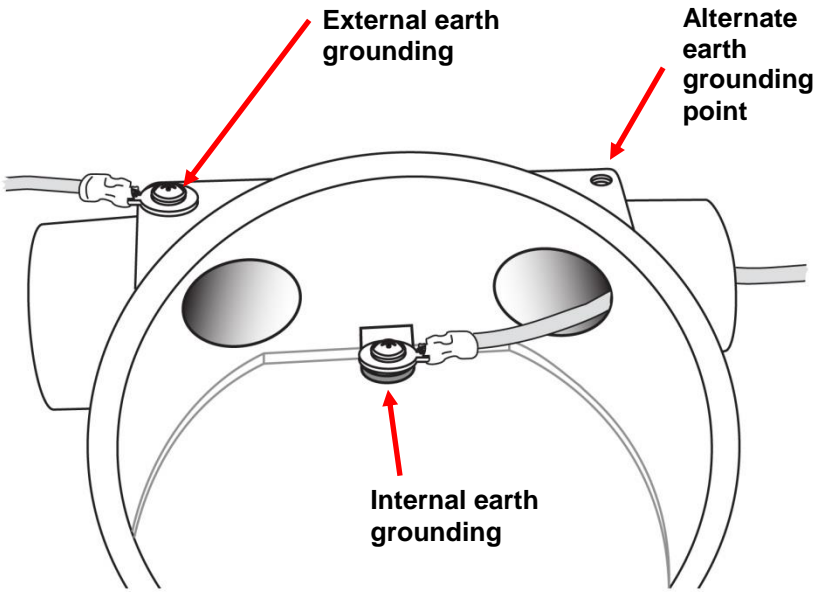



## RAEPoint User's Guide

### 15 Display/User Interface

The RAEPoint's user interface consists of four status LEDs. There are no buttons or controls. All settings are made internally.

### 16 Alarm Signal Summary

The following are reading-related alarms.

|              | Function                          | Host  | Remote   | Router                  |
|--------------|-----------------------------------|---|--|-------------------------|
| <b>Net</b>   | Network Status Indicator          | <ul style="list-style-type: none"> <li>• Blinks once per second if in network.</li> <li>• Off when there is no network</li> </ul> |  |                         |
| <b>Alarm</b> | Alarm Type Indicator              | <ul style="list-style-type: none"> <li>• On during any relay action</li> <li>• Blinks for any fault</li> </ul>                    | <ul style="list-style-type: none"> <li>• On during any relay action</li> <li>• Blinks for any fault</li> </ul> | Blinks for any fault    |
| <b>Comm</b>  | Communications Activity Indicator | <ul style="list-style-type: none"> <li>• Blinks for all communication</li> <li>• Off at any other time</li> </ul>                 |  |                         |
| <b>Mode</b>  | Device Type Indicator             | On  | Blinks once per second   | Blinks twice per second |

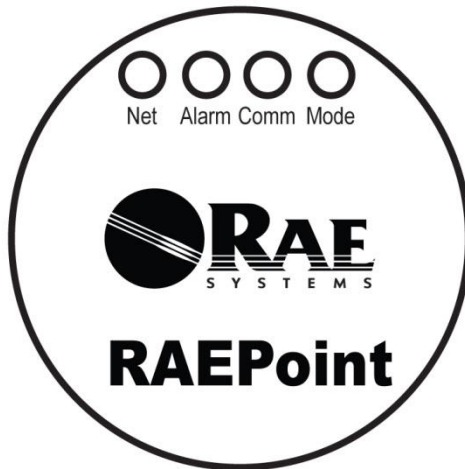

## RAEPoint User's Guide

### 16.1 RAEPoint Host

The LEDs on the RAEPoint Host indicate the following conditions:

|              |  |
|--------------|--|
| <b>Net</b>   | <ul style="list-style-type: none"><li>• Blinks when a network is established.</li><li>• Off when a network is absent.</li></ul>  |
| <b>Alarm</b> | <ul style="list-style-type: none"><li>• Glows solid red when detectors are in alarm</li><li>• Blinks red when detectors have a fault.</li><li>• Blinks red when DC supply voltage is below 11 volts.</li></ul> |
| <b>Comm</b>  | <ul style="list-style-type: none"><li>• Flashes when there is RF (radio frequency) send/receive activity.</li></ul>  |
| <b>Mode</b>  | <ul style="list-style-type: none"><li>• Glows solid green.</li></ul>   |

#### Notes

|                           |         |                 |
|---------------------------|---------|-----------------|
| <b>Relay Definitions:</b> | Relay 1 | Any alarms      |
|                           | Relay 2 | Any low alarms  |
|                           | Relay 3 | Any high alarms |
|                           | Relay 4 | High LEL alarms |
|                           | Relay 5 | High H2S alarms |

**IMPORTANT!** This is a fixed configuration and cannot be modified.

# RAEPoint User's Guide

## 16.2 RAEPoint Remote

**Note:** RAEPoint Remote can only operate with an FMC2000 Controller.

The LEDs on the RAEPoint Remote indicate the following conditions:

|              |  |
|--------------|--|
| <b>Net</b>   | <ul style="list-style-type: none"><li>• Blinks when a network is established.</li><li>• Off when a network is absent.</li></ul>                              |
| <b>Alarm</b> | <ul style="list-style-type: none"><li>• Glows solid red when detectors are in alarm</li><li>• Blinks red when DC supply voltage is below 11 volts.</li></ul> |
| <b>Comm</b>  | <ul style="list-style-type: none"><li>• Flashes when there is RF (radio frequency) send/receive activity.</li></ul>  |
| <b>Mode</b>  | <ul style="list-style-type: none"><li>• Blinks one time per second (green).</li></ul>  |

### Notes

**Relay Definitions:** The relays in the RAEPoint mirror the relays in the FMC2000 Controller on the same network. Definitions are set at the FMC2000 Controller.

# RAEPoint User's Guide

## 16.3 RAEPoint Router

**Note:** A RAEPoint Router can operate as a router for any device using the same radio type.

The LEDs on the RAEPoint Router indicate the following conditions:

|              |   |
|--------------|---|
| <b>Net</b>   | <ul style="list-style-type: none"><li>• Blinks when a network is established.</li><li>• Off when a network is absent.</li></ul> |
| <b>Alarm</b> | <ul style="list-style-type: none"><li>• Blinks red when DC supply voltage is below 11 volts.</li></ul>                          |
| <b>Comm</b>  | <ul style="list-style-type: none"><li>• Flashes when there is RF (radio frequency) send/receive activity.</li></ul>             |
| <b>Mode</b>  | <ul style="list-style-type: none"><li>• Blinks two times per second (green).</li></ul>  |

**Note:** RAEPoint purchased as a router does not contain relays.

## 17 Appendix A: Controlled Section

This section applies to the RAEPoint only. Information for the RAEPoint Wireless Alarm Bar is included in section 16.

### 17.1 Scope

The scope of this document is to identify the section of the RAEPoint controlled part of the manual.

### 17.2 Responsibility

The included sections cannot be changed without prior approval from the Notified Body.

### 17.3 Contents

Below are the sections controlled by the Notified Body, including all safety-related information in the manual.

Controlled sections are:

1. Warnings and directive information
2. Marking of the RAEPoint
3. Hazardous Location Classifications
4. Instructions for Safe Use
5. Connections and Ratings
6. Maintenance
7. Physical dimensions

# RAEPoint User's Guide

## 1. Warnings And Directive Information

### - READ BEFORE OPERATING -

This manual must be carefully read by all individuals who have or will have the responsibility of using, maintaining, or servicing this product. The product will perform as designed only if it is used, maintained, and serviced in accordance with the manufacturer's instructions.

### CAUTION!



To reduce the risk of electric shock, turn the power off before removing the instrument cover. Disconnect the power before removing the sensor module for service. Never operate the instrument when the cover is removed. Remove instrument cover and sensor module only in an area known to be non-hazardous.



Use of non-RAE Systems components will void the warranty and can compromise the safe performance of this product.

### WARNING!

Wireless communication is intended for use as a secondary remote alarm status notification only. Primary alarming of combustible gas hazards is provided locally by the detector.

# RAEPoint User's Guide



## 2. Marking Of RAEPoint

RAEPoint is certified according to ATEX and the IECEx scheme and CSA for US and Canada as protected by a flameproof enclosure, and the antenna barrier is used on intrinsically safe principles.

The product is marked with the following information:

RAE Systems Inc.  
3775 N. 1st. St.  
San Jose, CA95134 USA  
Serial number: XXXXXXXXXXXX  
Year of production

RAEPoint

| IECEX                 | ATEX   | North America                   |
|-----------------------|--|---------------------------------|
| IECEX SIR<br>12.0027X | Sira 12ATEX 1085X  | Cl.I Div 1, Group<br>A,B,C,D T6 |
| Ex d ia IIC T6,<br>Gb |  0575  II 2G, Ex<br>d ia IIC T6 Gb |                                 |

Temperature range:  $-20^{\circ}\text{C} \leq T_{\text{amb}} \leq 55^{\circ}\text{C}$

**WARNING: READ USER'S MANUAL FOR SAFETY PRECAUTIONS.**

**WARNING: DO NOT OPEN WHEN AN EXPLOSIVE ATMOSPHERE MAY BE PRESENT.**

**REFER TO USER MANUAL FOR ENTRY TYPE AND SIZE.**

# RAEPoint User's Guide

## 3. Hazardous Location Classification

### Hazardous Areas Classified By Zones

RAEPoint is intended to be used in hazardous areas classified for Zone 1 or Zone 2, within the temperature range of  $-20^{\circ}\text{C}$  to  $+55^{\circ}\text{C}$ , where gases of explosion groups IIA, IIB or IIC and T6 may be present.

### Hazardous Areas Classified By Divisions

RAEPoint is intended to be used in hazardous areas classified for Class I Div. 1 or 2, within the temperature range of  $-20^{\circ}\text{C}$  to  $+55^{\circ}\text{C}$ , where gases of explosion groups A, B, C or D and temperature class T6 may be present.

## 4. Instructions For Safe Use

The threaded coaxial connector external to the enclosure shall only be fitted with a dedicated antenna and shall not be used to supply an external, intrinsically safe circuit.

## 5. Connections And Ratings

### Input/Output

The rated RAEPoint input/output are as follows:

Input: 2.4W  $V_{\text{input}}$ : 12-28VDC

## 6. Maintenance

### Installation and Access Instructions

- An explosion-proof seal is required for all gas groups within 18" (46 cm) of the enclosure. The appropriate regulations for installation, service and repair must be properly observed during such activities.
- To prevent ignition of hazardous atmospheres, area must be free of flammable vapors and supply circuit must be disconnected before removing cover.

### **WARNING**

Negative terminal of power supply must be grounded.



# RAEPoint User's Guide

## Earth Grounding Instructions

### External Earth Grounding

Fasten the crimped ground wire with hardware as illustrated here. The wire should have a minimum cross-section area of  $4\text{mm}^2$  for its conductor.

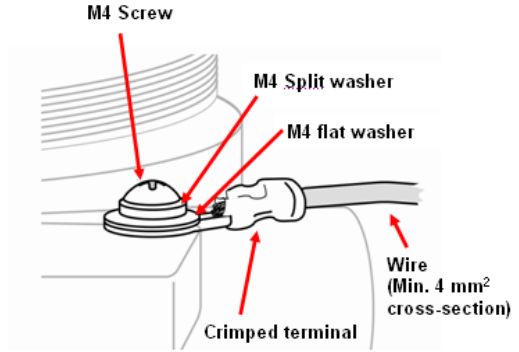

### Internal Earth Grounding

Use the same hardware as shown in the illustration of external earth grounding. The wire should be no less than the size of the power lines.

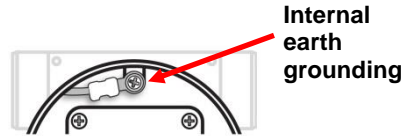

### Finished Grounding Wires

Internal and external grounding are shown here, as well as an alternate external grounding point. Always follow local electrical guidelines.

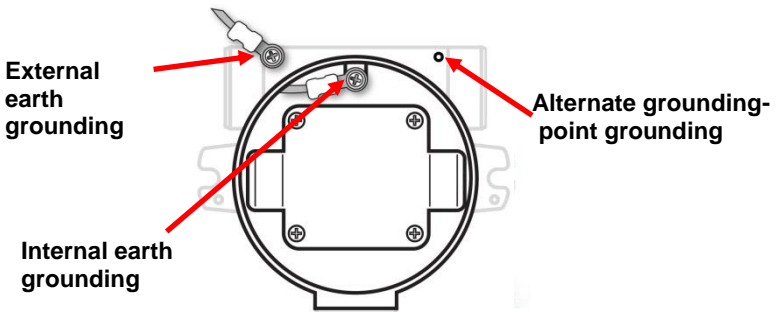

# RAEPoint User's Guide

## 7. Physical Dimensions

RAEPoint can be easily installed and integrated with various control systems with its flexible pipe-holding/wall-mounting options and standard connection terminals.

**Entries:** RAEPoint is provided with three female 3/4" - 14 NPT cable entry holes tapped into its side walls; one 3/4" - 14 NPT containing the antenna coupler for mounting of the external antenna.

The physical dimensions are as follows:

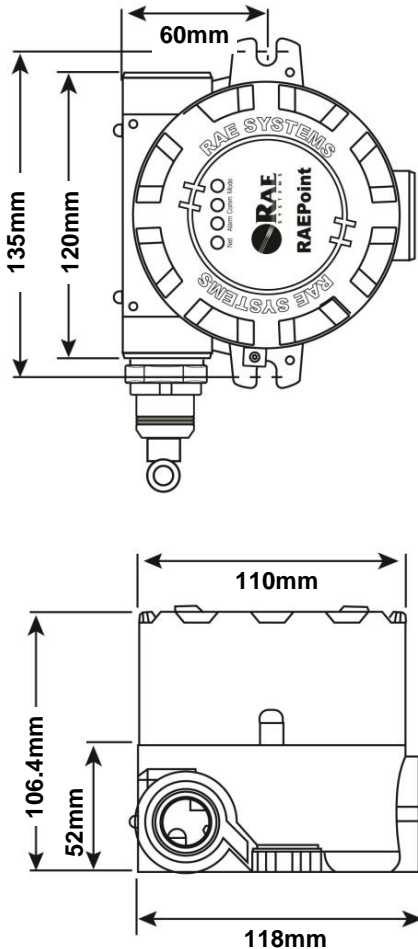

# RAEPoint User's Guide

## 8. Models Of RAEPoint

| <b>Model Number</b> | <b>Product Name</b>                                 |
|---------------------|---|
| RRA2000             | RAEPoint Wireless Switch Remote                     |
| RRA2000             | RAEPoint Wireless Router                            |
| RRA2000             | RAEPoint Wireless Switch Host /<br>RAEPoint GateWay |

### 18 Technical Support

To contact RAE Systems Technical Support:

Monday through Friday, 7:00AM to 5:00PM Pacific (US) Time

**Phone (toll-free):** +1 888-723-4800

**Phone:** +1 408-952-8461

**Email:** tech@raesystems.com

### 19 RAE Systems Contacts

**RAE Systems by Honeywell**

**World Headquarters**

3775 N. First St.

San Jose, CA 95134-1708 USA

**Phone:** +1 408.952.8200

**Fax:** +1 408.952.8480

**E-mail:** customerserv@raesystems.com

**Web Site:** www.raesystems.com

**RAE Systems Technical Support**

Monday through Friday, 7:00AM to 5:00PM Pacific Time

**Phone:** +1.408.952.8461

**Email:** tech@raesystems.com

## RAEPoint User's Guide

### **EMEI Headquarters**

Life Safety Distribution AG

Javastrasse 2

8604 Hegnau, Switzerland

**Phone:** +41 (0)44 943 4300

**Fax:** +41 (0)44 943 4398

**Email:** haexpert@honeywell.com

### **RAE Systems France**

ZI des Ayats

679390 MILLERY

France

**Phone:** +33 4 78 46 16 65

**Fax:** +33 4 78 46 25 98

**Phone:** +33 4 78 46 16 65

**Fax:** +33 4 78 46 25 98

**Email:** info-france@raeurope.com

**Web:** www.raesystems.fr

### **RAE BeNeLux BV**

Rijndal 20

2904 DC Capelle a/d IJssel

Netherlands

**Phone:** +31 10 4426149

**Fax:** +31 10 4426148

**Email:** info@rae.nl

**Web:** www.rae.nl

### **RAE Systems Spain, s.l.**

Av. Remolar, 31

08820 El Prat de Llobregat

Spain

**Phone:** +34 933 788 352

**Fax:** +34 933 788 353

**Email:** info@raespain.com

**Web:** www.raespain.com

## RAEPoint User's Guide

### **RAE Systems by Honeywell**

#### **Brazil Office**

Av. Marginal da Rodovia dos Bandeirantes, 100 Jundiaí - SP

ZIP: 13213-008 Brazil

**Phone:** +55.11.3309.1030

**Fax:** +55.11.3309.1035

**Email:** HALA@honeywell.com

**Web:** www.raesystems.com.br

### **RAE Systems (Hong Kong) Ltd.**

Room 8, 6/F, Hong Leong Plaza

33 Lok Yip Road

Fanling, N.T, Hong Kong

**Phone:** +852.2669.0828

**Fax:** +852.2669.0803

**Email:** hksales@raesystems.com

### **RAE Systems Japan**

Marunouchi Nakadori Bldg 6F-617-B,

2-3, Marunouchi 2-Chome, Chiyoda-ku,

Tokyo, 100-0005 Japan

**Phone:** +81-3-6269-9646

**Fax:** +81-3-6269-9647

**Email:** jpsales@raesystems.com

### **RAE Systems Korea**

#1010, DaeMyungAnsVill First,

Sang-Dong 412-2, Wonmi-Gu, Bucheon,

Kyungki-Do, Korea

**Phone:** 82-32-328-7123

**Fax:** 82-32-328-7127

**Email:** krsales@raesystems.com



## **CORPORATE HEADQUARTERS**

### **RAE Systems by Honeywell**

3775 North First Street

San Jose, CA 95134 USA

Phone: 408.952.8200

Fax: 408.952.8480

[customerserv@raesystems.com](mailto:customerserv@raesystems.com)

## **WORLDWIDE SALES OFFICES**

**USA/Canada** 1.877.723.2878

**EMEA** +41.044.943.4300

**China** +86.10.5885.8788-3000

**Asia Pacific** +852.2669.0828