

52.9i, 62.9i, 682.9cf, 692.9i

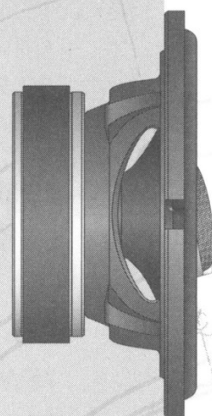

kappa[®] series

529i, 6929i

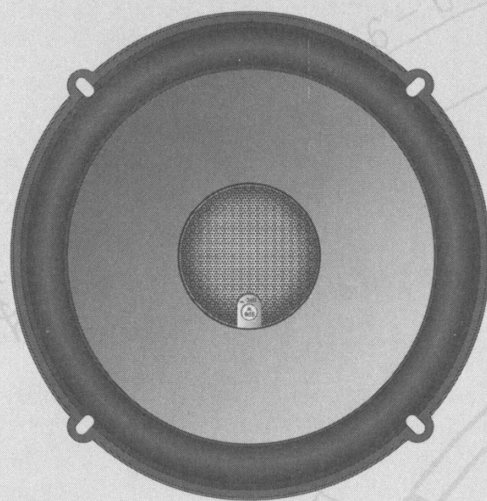
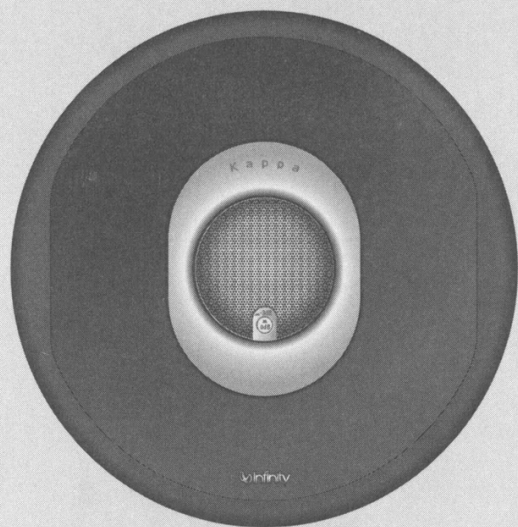
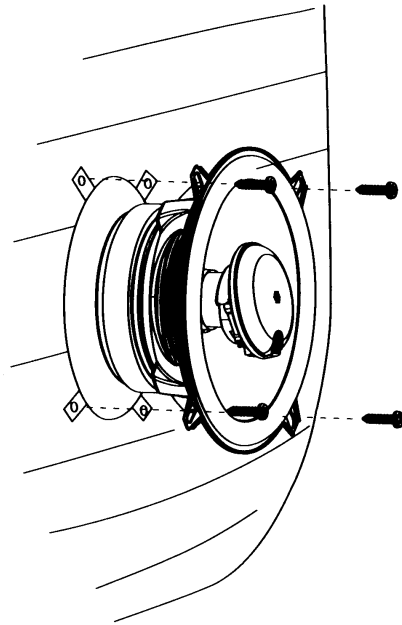
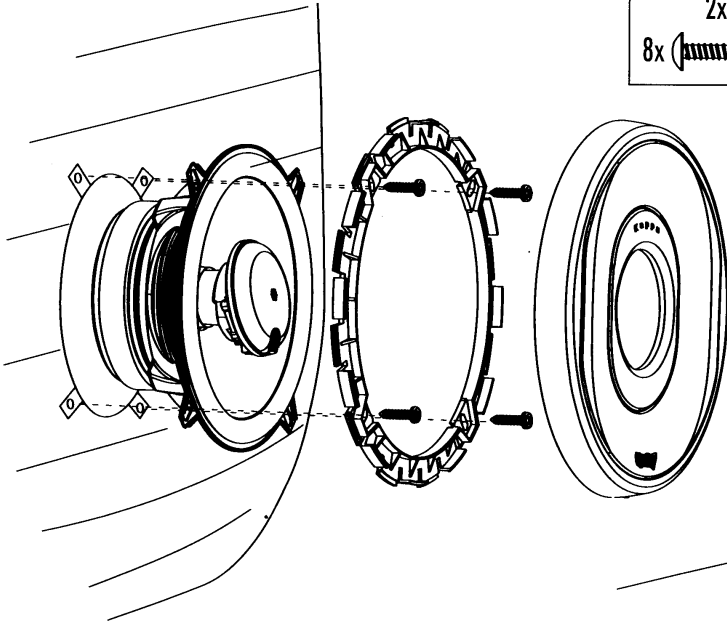
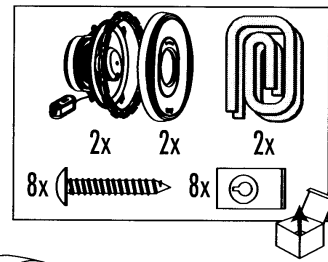

6829cf

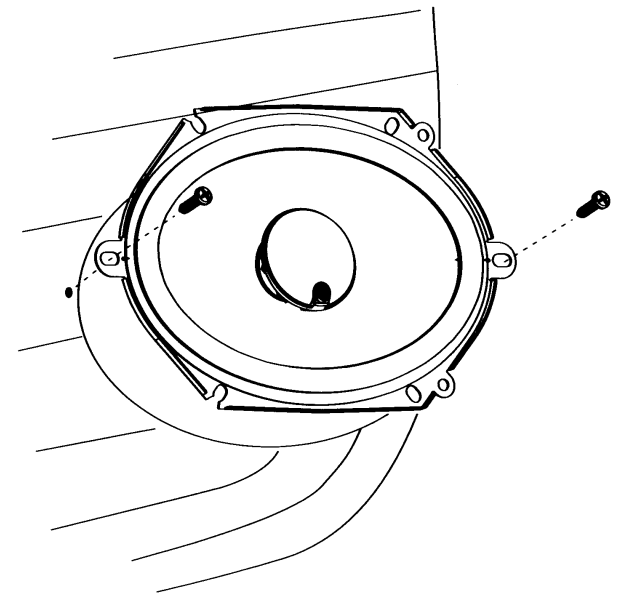
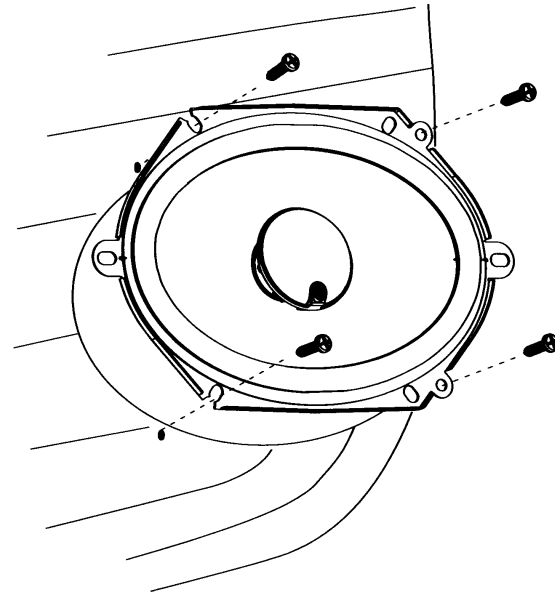
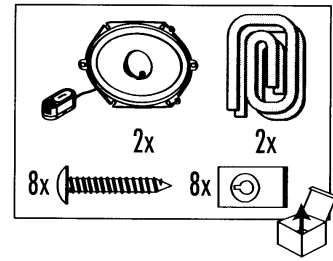

629i

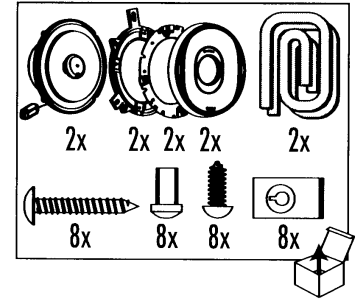
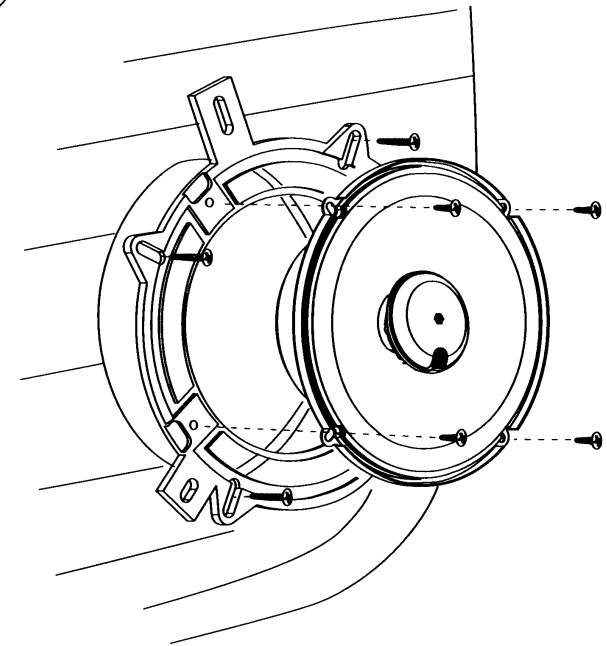
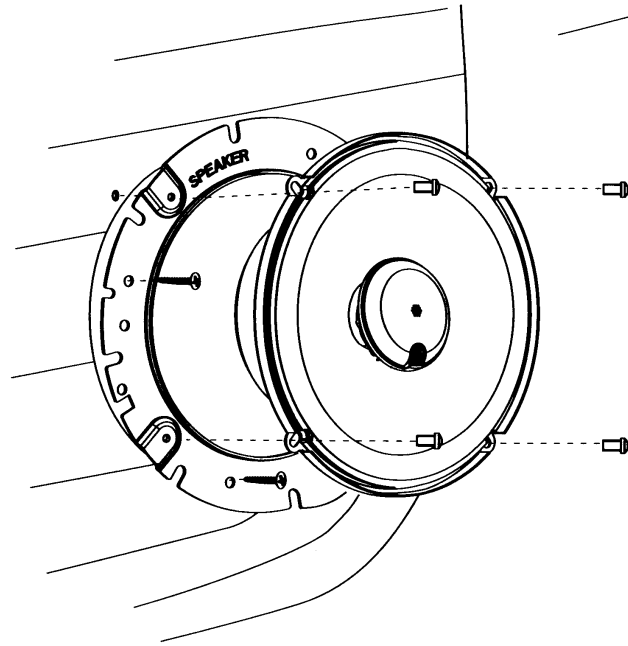
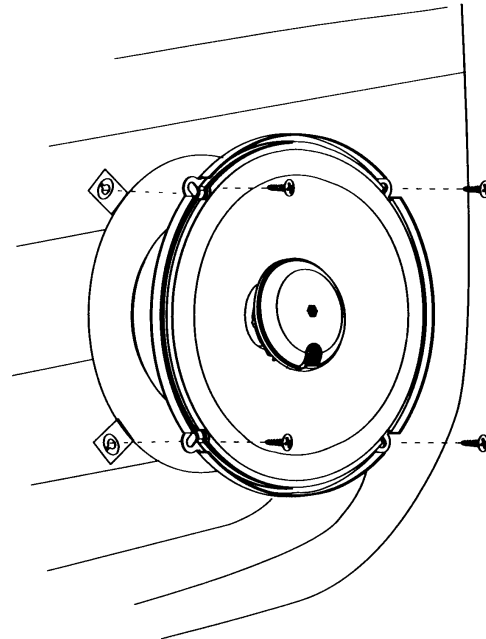
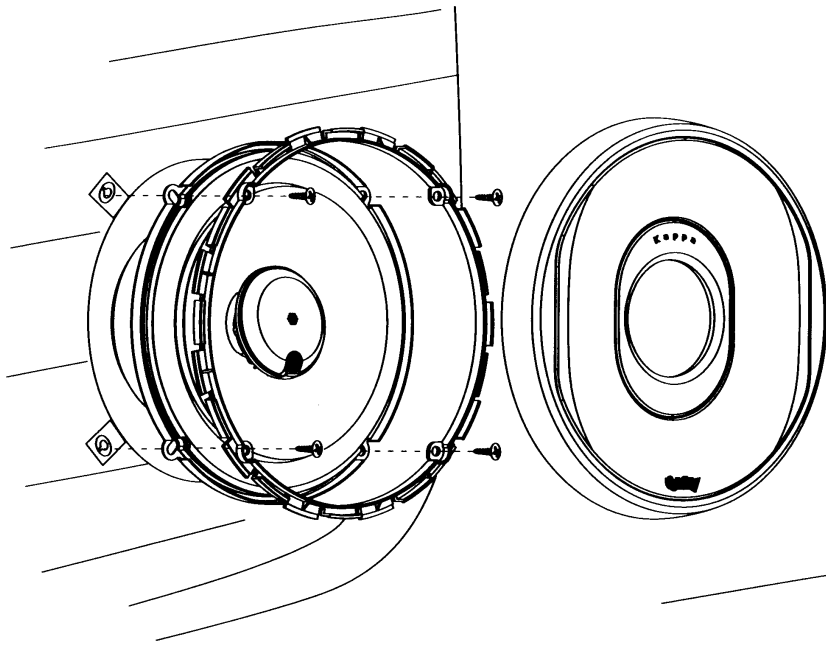

529i, 629i, 6829cf, 6929i

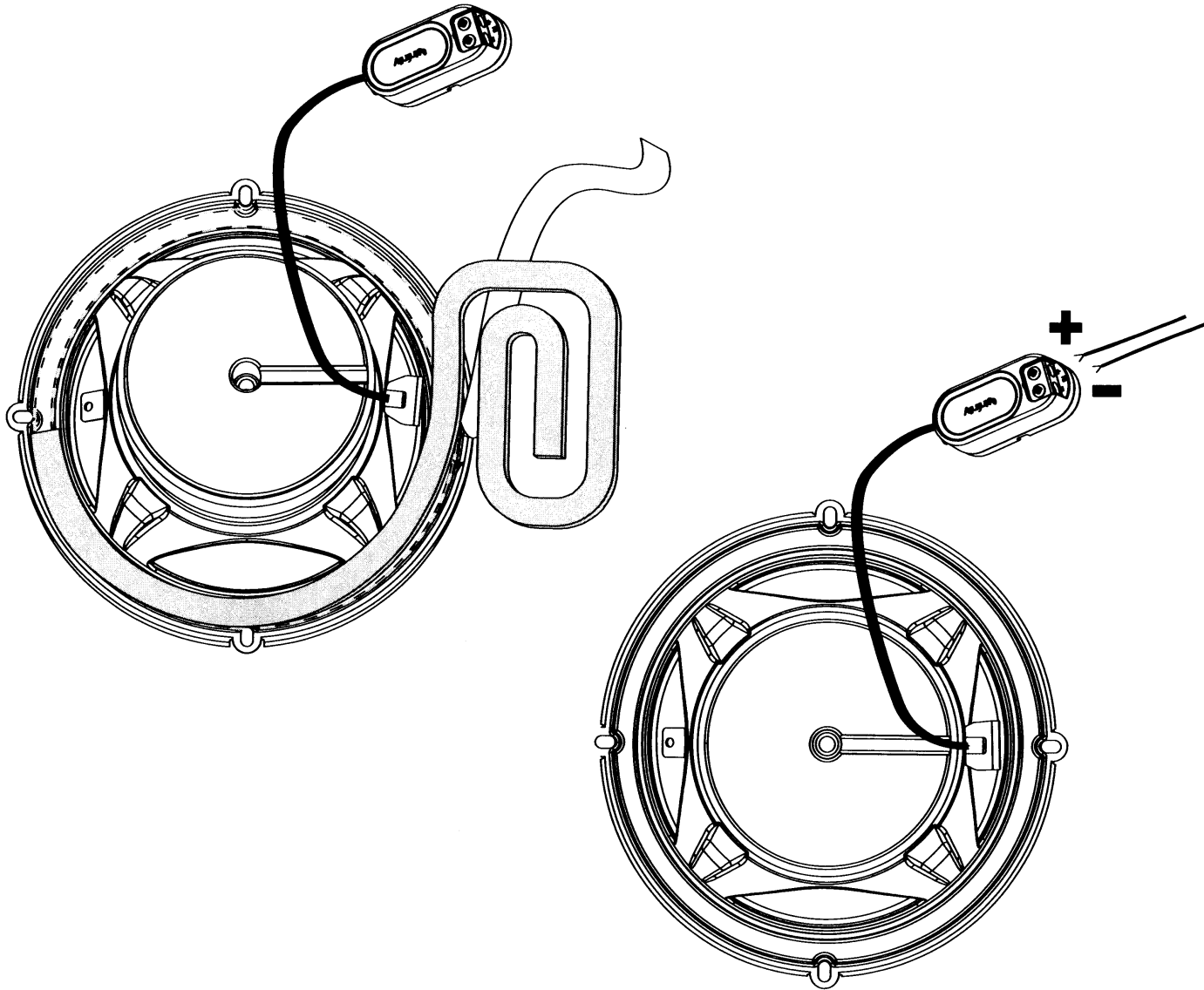

529i, 629i,
6829cf, 6929i

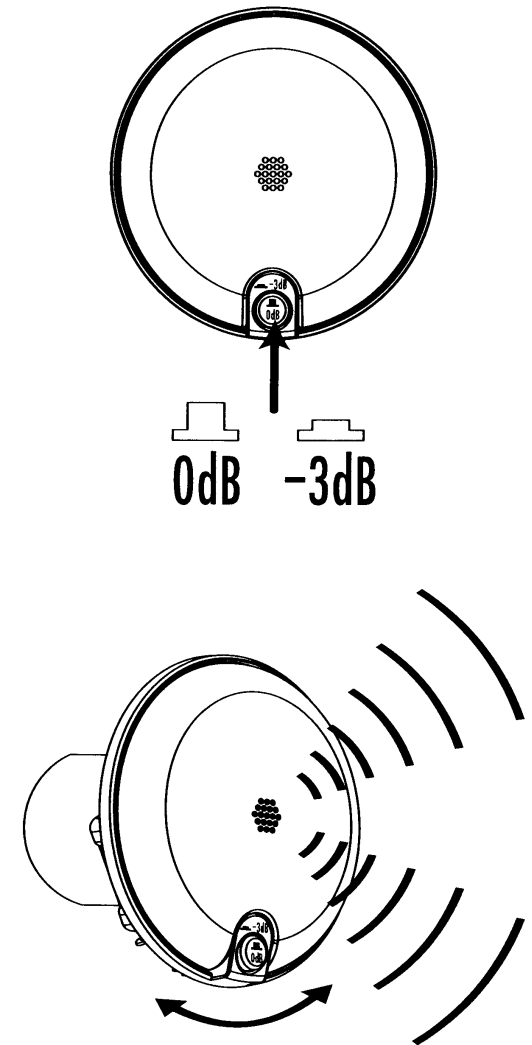

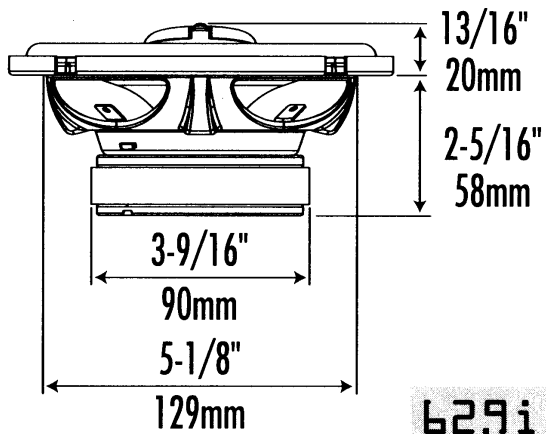

629i

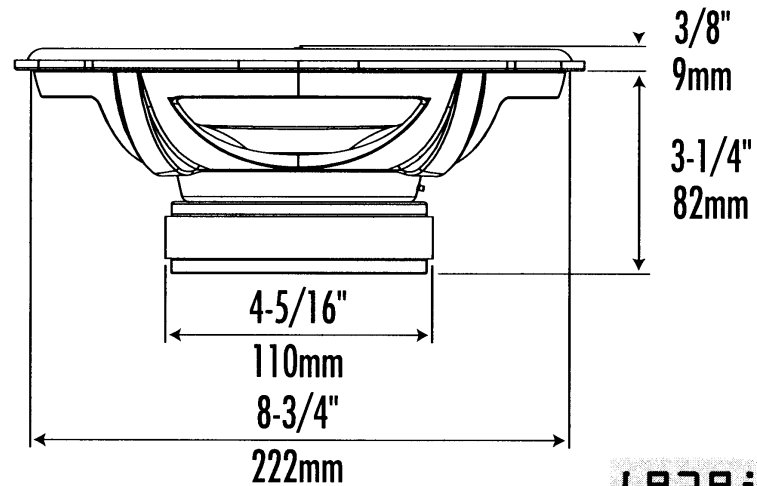
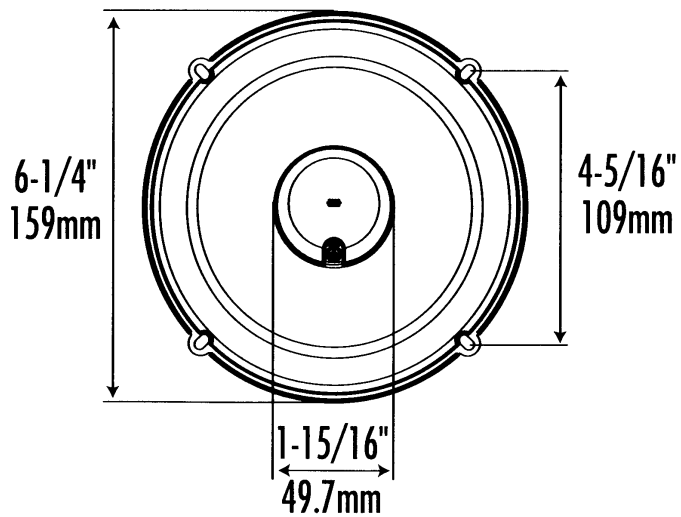

6929i

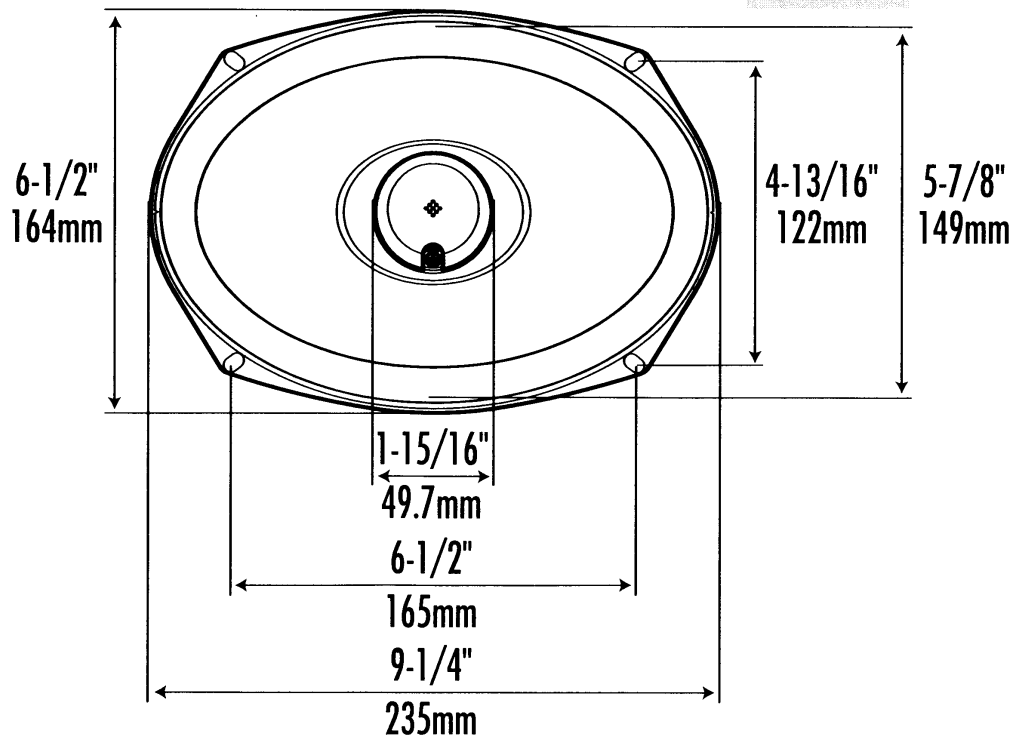

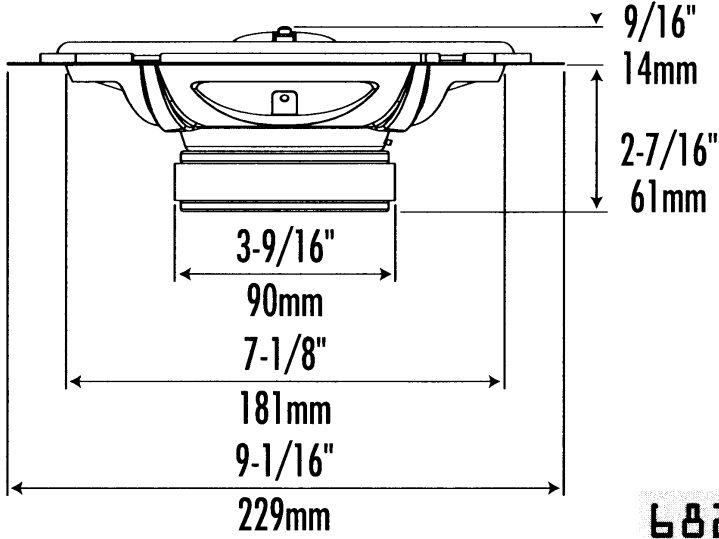

6829cf

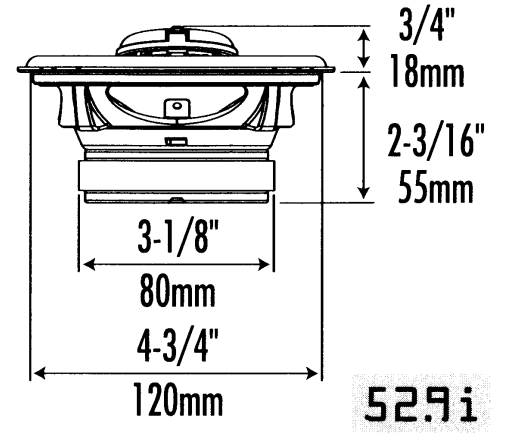

529i

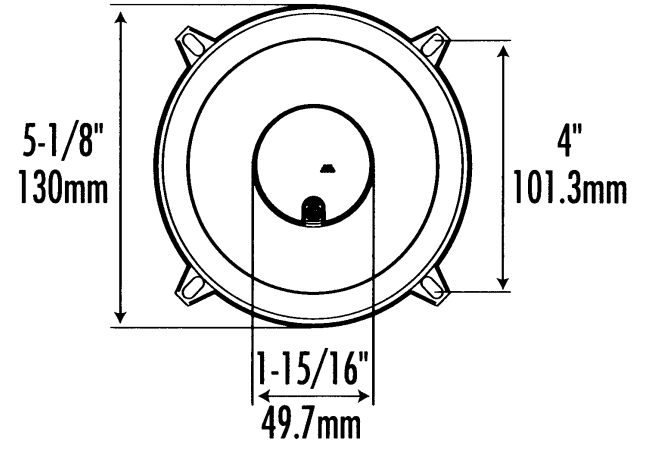
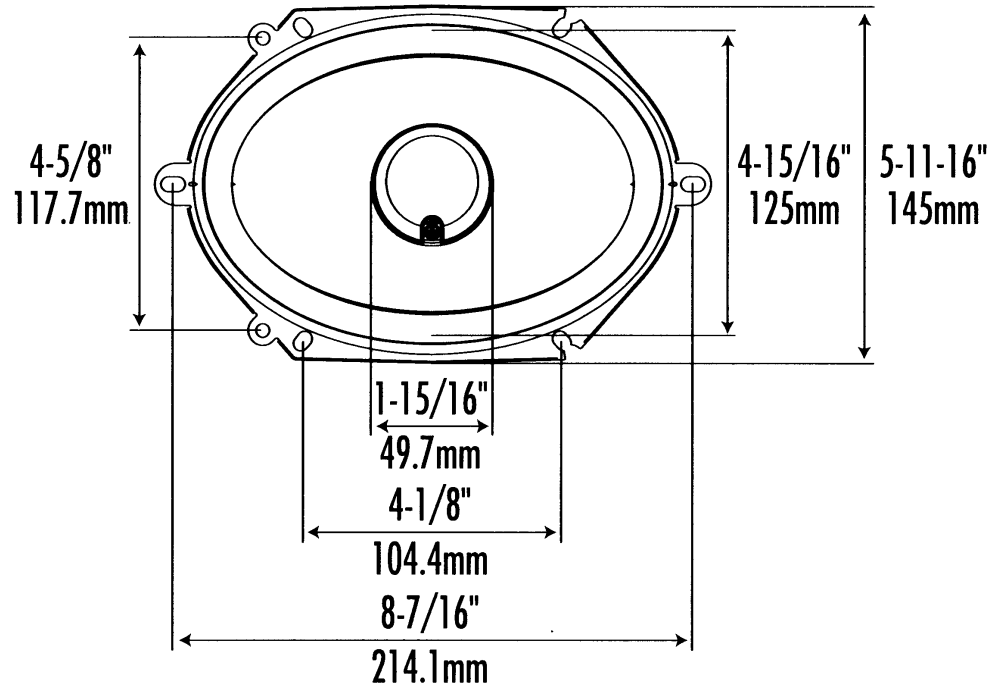

| | 52.9i | 62.9i | 682.9cf | 692.9i |
|------------|--------------|--------------|----------------|---------------|
| BL (T-m) | 3.54 | 4.10 | 4.14 | 5.50 |
| DCR (ohms) | 2.37 | 2.25 | 2.50 | 2.25 |
| Mms (g) | 8.55 | 12.59 | 15.06 | 24.87 |
| Sd (sq cm) | 102.1 | 141.0 | 164.0 | 230.9 |
| Cms (µm/N) | 381 | 325 | 300 | 304 |
| Vas (l) | 5.57 | 9.07 | 11.33 | 22.76 |
| Fs (Hz) | 88.2 | 78.7 | 74.9 | 57.9 |
| Qes | 0.90 | 0.83 | 1.03 | 0.67 |
| Qms | 6.35 | 8.00 | 6.55 | 8.27 |
| Qt | 0.79 | 0.75 | 0.89 | 0.62 |
| 1wSPL (dB) | 88.2 | 89.2 | 88.6 | 90.1 |

SPECIFICATIONS

| | 52.9i | 62.9i | 682.9cf | 692.9i |
|--------------------------|--------------|-----------------------|---------------------------------------|---------------|
| Type: | 5-1/4" 2-Way | 6-1/2" • 6-3/4" 2-Way | 6" x 8" 5/8" x 7" 2-Way Custom Fit | 6" x 9" 2-Way |
| Nominal Impedance: | 2 Ohms | 2 Ohms | 2 Ohms | 2 Ohms |
| Power Handling, RMS: | 55W | 75W | 100W | 110W |
| Power Handling, Peak: | 165W | 225W | 300W | 330W |
| Frequency Response: | 55Hz – 25kHz | 45Hz – 25kHz | 40Hz – 25kHz | 35Hz – 25kHz |
| Sensitivity (2.83V, 1m): | 94dB | 95dB | 94dB | 96dB |

GENERAL CARE: The loudspeaker grilles may be cleaned with a damp cloth. Do not use any cleaners or solvents on the grilles or the speaker cones.

WARRANTY: Kappa® Series speakers are warranted against defects. The duration of the speaker's warranty depends on the laws in the country in which it was purchased. Your local Infinity car audio retailer can help you determine the length of your warranty. To register your product, please visit us at www.infinitysystems.com.



A valid serial number is required for warranty coverage.
Features, specifications and appearance are subject to change without notice.
This product is designed for mobile applications and is not intended for connection to the mains.
Harman Consumer Group, Inc. • 2 route de Tours, 72500 Château du Loir, France • www.infinitysystems.com
© 2008 Harman International Industries, Incorporated. All rights reserved. Part No. KappaMEBBOM2/08
Infinity and Kappa are trademarks of Harman International Industries, Incorporated,
registered in the United States and/or other countries.
H A Harman International Company



Declaration of Conformity

CE

We, Harman Consumer Group, Inc.
2, route de Tours
72500 Château du Loir
France

declare in own responsibility that the products described in this owner's manual
are in compliance with technical standards:

EN 61000-6-3:2001
EN 61000-6-1:2001

Klaus Lebherz
Harman Consumer Group, Inc.
Château du Loir, France 2/08

We need to hear from you!

- Warranty Service
- Confirmation of Ownership

In the world of high fidelity, technology is all too often viewed as the end product. At Infinity®, we have a different viewpoint: technology is only the means to an end. The end result must be enjoyment of the programs and music you hear.



Thanks for choosing Infinity

Register your purchase via the Internet at:

<http://www.infinitysystems.com>

Click on "Product Support"

Click on "Owner's Registration"

LIMITED THREE-YEAR WARRANTY

Infinity Kappa® and Kappa Perfect (applies to USA only)

A valid serial number is required for warranty coverage.

WHO IS PROTECTED BY THIS WARRANTY?

Your Infinity warranty protects the original owner and all subsequent owners for a period of three (3) years (parts and labor) for all loudspeaker and/or electronic components from any failure as a result of an original manufacturing defect so long as: (1) your Infinity product was originally purchased within the fifty United States or by military personnel from an authorized military outlet, (2) the dealer from whom the product was purchased was authorized by Infinity to sell such products at the time of original purchase and (3) the original, dated Bill of Sale is presented whenever service is required during the warranty period. This warranty is only valid for service within the United States and does not apply to products purchased elsewhere; other purchasers should contact their local Infinity distributor for warranty information.

WHAT DOES THE INFINITY WARRANTY COVER?

Except as specified below, this warranty covers all defects in original materials and workmanship. The following are not covered: damage caused by accident, misuse, abuse, neglect, product modification; damage occurring during shipment; damage caused by failure to follow instructions in the owner's guide, including failure to perform recommended periodic or routine maintenance; damage resulting from repairs by someone not authorized by Infinity; units used for other than car use; units not used for their intended purpose; claims based upon any misrepresentations by the seller; and any Infinity product on which the serial number has been altered, defaced or removed.

NOTE: Repair of our products must be done by an authorized dealer or service center. **Unauthorized repair will void the warranty and is done at the risk of the consumer.**

WHO PAYS FOR WHAT?

During the period of this warranty, subject to the above conditions, Infinity will pay all of the labor and material expenses to repair a warrantable defect.

HOW CAN WARRANTY SERVICE BE OBTAINED?

In the event that your Infinity product(s) should require service, you should first contact either the Infinity dealer from whom the product was purchased or an authorized service center. For the name of an Infinity service center, visit our Web site at www.infinitysystems.com, write us directly at Infinity (ATTN: Customer Service), 250 Crossways Park Drive,

Woodbury, NY 11797, or call 516.674.4INF (4463). We may direct you to an authorized service center for Infinity products or ask you to send the product to us for repair. In either case, you will have to present your original Bill of Sale to establish warranty coverage. Do not send your product to us without prior authorization from our Customer Service Department. You are responsible for transporting your product to either Infinity or an authorized service center and for payment of all shipping charges; however, Infinity will pay the return shipping charges (in the event you return the product to us) if the repairs are covered by warranty. If you experience difficulty in transporting your product or are in need of packing materials, please advise us and we may be able to suggest alternative procedures and/or provide adequate packing materials.

LIMITATION OF IMPLIED WARRANTIES: All implied warranties, including fitness for a particular purpose and merchantability, are limited in duration and length to the warranty period for your product.

LIMITATION OF INCIDENTAL OR CONSEQUENTIAL DAMAGES: Infinity is not responsible for incidental or consequential damage of any kind. Our liability is limited to the repair or replacement, at our option, of a defective product.

Some states do not allow limitations on how long an implied warranty lasts and/or do not allow the exclusion of incidental or consequential damages, so the above limitations or exclusions may not apply to you. This warranty gives you specific legal rights and you may also have other rights, which vary, from state to state.

NOTE: In the event that there is a difference between this warranty and the provisions in any advertisements, product brochure or packaging cartons, the terms of this warranty will prevail.

Infinity continually strives to update and improve existing products, as well as create new ones. The specifications and construction details in this and related Infinity publications are, therefore, subject to change without notice.

© 2003 Harman International Industries, Incorporated. P/N: KAP3-YRWTY REV. 9/03
Infinity Systems, 250 Crossways Park Drive, Woodbury, NY 11797 USA 516.674.4INF (4463)
H A Harman International Company
Infinity is a registered trademark of Harman International Industries, Incorporated.

PLEASE MAKE NOTE OF THE FOLLOWING INFORMATION AND RETAIN FOR YOUR RECORDS

Product Name: _____

Model Number: _____

Store Name: _____

Date of Purchase: _____