

## 2

## ANIMAL KINGDOM

**BASIS OF CLASSIFICATION****1. Levels of Organisation**a) **cellular level of organization:**

Here the cells are arranged as loose cell aggregates. Some division of labour (activities) occur among the cells

**Eg: Phylum Porifera (Sponges)**

b) **Tissue level of organization :**

Here the cells performing the same function are arranged into tissues

**Eg :Phylum coelenterate (Cnidaria)**

**Phylum – Ctenophora**

c) **Organ level of organization :**

Here tissues are organized to form organs. Each Organs are specialized for a particular function

**Eg: Phylum : Platyhelminthes (Flat worms)**

d) **Organ system level of organization :**

Here various organs are grouped organ system. Each system concerned with a specific physiological function

**Eg:**

**Phylum Aschelminthes**

**Phylum Annelids,**

**Phylum Arthropods,**

**Phylum Molluscs**

**Phylum Echinoderms**

**Phylum Hemichordates**

**Phylum Chordates**

**2. Types of digestive system**

a) **Incomplete digestive system :** Here the organism has single opening, it act as both mouth and anus

**Eg: Phylum Cnidaria,**

**Phylum Ctenophora**

**Phylum Platyhelminthes**

a) **Complete digestive system:** A complete digestive system has two openings, mouth and anus

**Eg**

**Phylum Aschelminthes to Chordates**

- **Digestive system absent in Phylum Porifera**

**3. Types of circulatory system**a) **open type of circulatory system :**

in which the blood is pumped out of the heart and the cells and tissues are directly bathed in it

**Eg: Phylum Arthropoda**

**Phylum Mollusca**

**Phylum Hemichordata**

b) **closed type of circulatory system :** in which the blood is circulated through a series of vessels of varying diameters (arteries, veins and capillaries)

**4. Symmetry :**

Animals can be categorized on the basis of their symmetry.

a) **Asymmetry :**

Here the body cannot be divided into two equal halves in any plane

Or

Any plane that passes through the centre does not divide them into equal halves

**Eg: Phylum Porifera**

**(Porifera shows various type of symmetry)**

b) **Radial symmetry :**

When any plane passing through the central axis of the body divides the organism into two identical halves

**Eg; Phylum Coelenterata**

**Phylum Ctenophora**

**Phylum Echinodermata**

c) **Bilateral symmetry :**

Here the body can be divided into identical left and right halves in only one plane is called Bilateral symmetry.

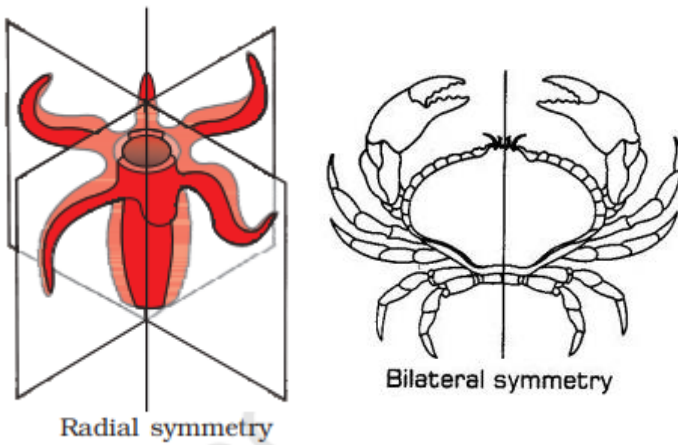

## 5. Germ layers

### a) Diploblastic animals :

Animals in which the cells are arranged in two embryonic layers,

- An external ectoderm and
- An internal endoderm,

are called diploblastic animals, An undifferentiated layer, mesoglea, is present in between the ectoderm and the endoderm

e.g., **Phylum : coelenterate**

**Phylum : Ctenophora**

### b) Triploblastic animals :

Those animals in which the developing embryo has a Three germinal layer, such as

- Ectoderm,
- Endoderm and
- Mesoderm

are called triploblastic animals, Here the mesoderm is located in between the ectoderm and endoderm,

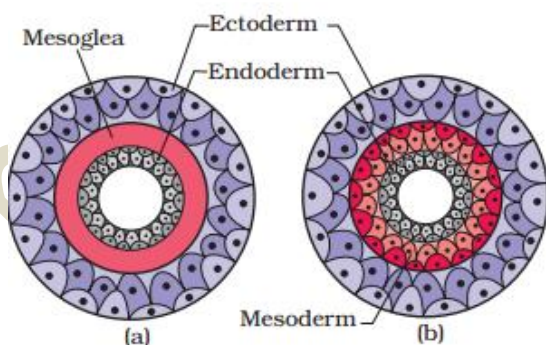

## 6. Coelom :

The cavity present between body wall and gut is called **Coelom**. The body cavity is lined by **mesoderm**. Based On Coelom animals are classified into

### a) coelomates

Animals possessing coelom are called coelomates,

e.g., **annelids, molluscs, arthropods, echinoderms, hemichordates and chordates**

### b) Acoelmate :

Animals without coelom

Eg: Porifera, cnidaria, ctenophore, Platyhelminthes

### c) Pseudocoelomates:

In some animals, the body cavity is not lined by mesoderm, **instead, the mesoderm is present as scattered pouches in between the ectoderm and endoderm**. Such a body cavity is called pseudocoelom and the animals possessing them are called pseudocoelomates, e.g., Phylum aschelminthes

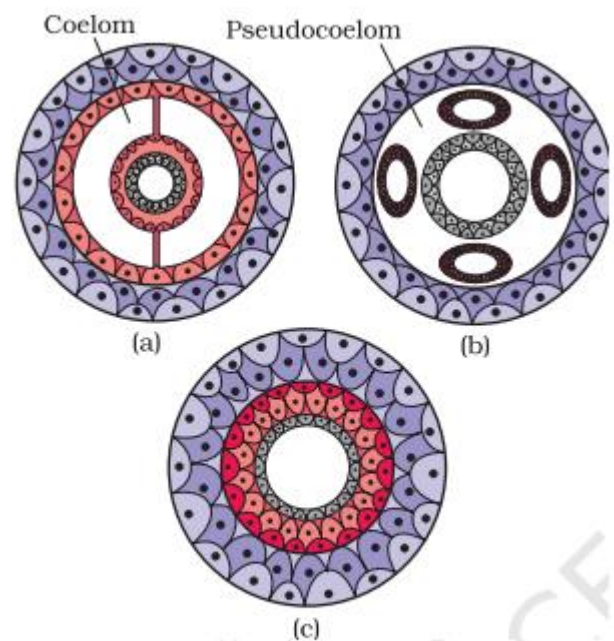

Diagrammatic sectional view of :  
(a) Coelomate (b) Pseudocoelomate  
(c) Acoelomate

## 7. Segmentation

In some animals, the body is externally and internally divided into segments.

For example, in earthworm, the body shows this pattern called metameric segmentation and the phenomenon is known as **metamerism**. In earthworm each segment is called **metamere**.

**8. Chordates and non-chordates :**

**Notochord** is a mesodermally derived rod-like structure formed on the **dorsal side** during embryonic development in some animals. Based on the presence or absence of notochord animals are classified into Chordates and non chordates.

**a)Chordata :**

Animals with notochord are called chordates

**b)Non-Chordata**

Those animals which do not form notochord are called non-chordates,

**e.g., Porifera to Echinoderms.**

**CLASSIFICATION OF ANIMALS**

The animals are classified into 35 phylum of which 11 phylum are consider as the major phylum . they are given below

1. Phylum Porifera
2. Phylum Cnidaria
3. Phylum Ctenophora
4. Phylum platyheminthes
5. Phylum Aschelminthes
6. Phylum Annelida
7. Phylum Arthrod-poda
8. Phylum Mollusca
9. Phylum Echinodermata
10. Phylum Hemichordata
11. Phylum Chordata

# 1. Phylum Porifera

- Members of this phylum are commonly known as **sponges**.
- They are generally marine (**Except Spongilla**, its fresh water sponge)
- Mostly asymmetrical animals.
- These are primitive multicellular animals and have cellular level of organisation.
- Sponges have a **water transport or canal system**. Water enters through minute pores (ostia) in the body wall into a central cavity, spongocoel, from where it goes out through the osculum. This pathway of water transport is helpful in food gathering, respiratory exchange and removal of waste.

Water → Ostia → Spongocoel → Osculum

- **Choanocytes or collar cells** line the spongocoel and the canals.
- Digestion is intracellular.
- The body is supported by a skeleton made up of spicules or spongin fibres.
- Sexes are not separate (hermaphrodite), i.e., eggs and sperms are produced by the same individual.
- Sponges reproduce asexually by fragmentation and sexually by formation of gametes.
- Fertilisation is internal and development is indirect having a larval stage which is morphologically distinct from the adult.

**Examples: Sycon (Scypha),**

**Spongilla (Fresh water sponge)**

**Euspongia (Bath sponge).**

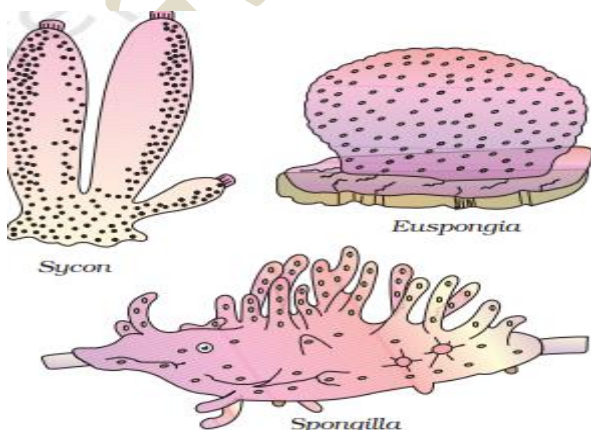

# 2. Phylum Cnidaria

## (Coelenterata)

- They are aquatic, mostly marine, sessile (Attached) or free-swimming,
- **Radially symmetrical** animals.
- Cnidarians exhibit tissue level of organization
- They are diploblastic
- The name cnidaria is derived from the **cnidoblasts or cnidocytes** (which contain the stinging capsules or nematocytes) present on the tentacles and the body.

### Functions of Cnidoblasts

- ✓ It is used for anchorage,
- ✓ It is used defense and
- ✓ It is used for the capture of prey



Diagrammatic view of Cnidoblast

- They have a central gastro-vascular cavity with a single opening, mouth on **hypostome**.
- Digestion is extracellular and intracellular.
- Some of the cnidarians, e.g., corals have a skeleton composed of **calcium carbonate**.
- Cnidarians exhibit **two basic body forms** called **polyp and medusa**. The Polyp is a sessile and cylindrical form like Hydra, Adamsia, etc. whereas, the Medusa is umbrella-shaped and free-swimming like Aurelia or jelly fish. Those cnidarians which exist in both forms **exhibit alternation of generation (Metagenesis)**, i.e., polyps produce medusae asexually and medusae form the polyps sexually (e.g., Obelia).

Polyp	Medusa
Sessile	Free swimming type
Cylindrical form	Umbrella shape
It produce medusa by	It produce polyp



asexual reproduction	sexual reproduction
Eg: Hydra, Adamsia	Eg:Aurelia (Jelly fish)

Examples:

**Physalia (Portuguese man-of-war),  
Adamsia (Sea anemone),  
Pennatula (Sea-pen),  
Gorgonia (Sea-fan) and  
Meandrina (Brain coral).**

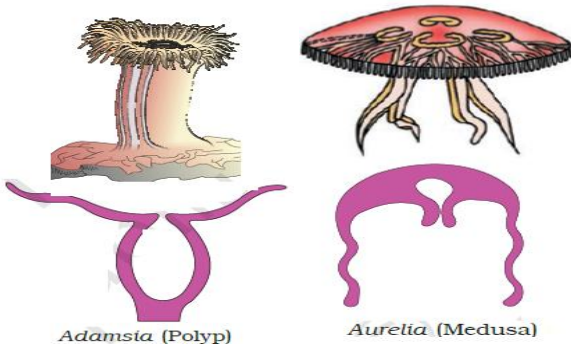

Adamsia (Polyp)

Aurelia (Medusa)

### 3. Phylum – Ctenophora

- Ctenophores, commonly known as **sea walnuts or comb jellies**
- They are exclusively marine, **radially symmetrical**, diploblastic
- Organisms with tissue level of organisation.
- The body bears eight external rows of **ciliated comb plates, which help in locomotion**
- Digestion is both extracellular and intracellular.
- **Bioluminescence (the property of a living organism to emit light) is well-marked in ctenophores.**
- Sexes are not separate. Reproduction takes place only by sexual means. Fertilisation is external with indirect development
- **Examples: Pleurobrachia and Ctenoplana**

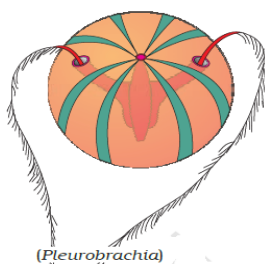

(Pleurobrachia)

### 4. Phylum platyhelminthes

- They have **dorso-ventrally flattened body**, hence are called **flatworms**
- Flatworms are bilaterally symmetrical,
- They are triploblastic
- They are **acoelomate animals with organ level of organisation.**
- These are mostly **endoparasites** found in animals including human beings

#### Parasitic adaptations

- Hooks and suckers are present in the parasitic forms.
  - Some of them absorb nutrients from the host directly **through their body surface.**
  - Presence of anaerobic respiration**
- Specialised cells called **flame cells** help in **osmoregulation and excretion.**
  - Sexes are not separate. Fertilisation is internal and development is through many larval stages. Some members like **Planaria** possess **high regeneration capacity.**
  - **Examples: Taenia (Tapeworm), Fasciola (Liver fluke).**

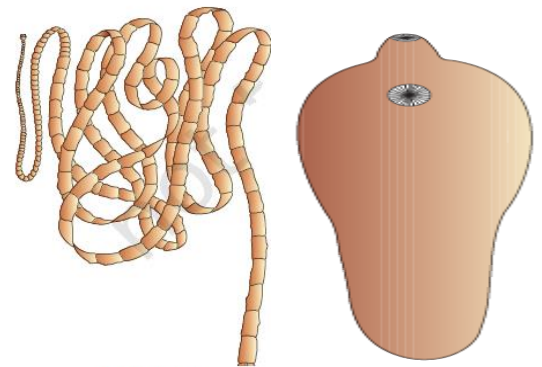

Tapeworm

Liver fluke

### 5. Phylum Aschelminthes

- The body of the aschelminthes is **circular in cross-section, hence, the name roundworms**
- They may be freeliving, aquatic and terrestrial or parasitic in plants and animals.
- Roundworms have organ-system level of body organisation.
- They are bilaterally symmetrical, triploblastic and **pseudocoelomate animals.**
- Alimentary canal is complete with a well developed muscular pharynx.

- An excretory tube removes body wastes from the body cavity through the excretory pore.
- Sexes are separate (dioecious), i.e., males and females are distinct.
- **Often females are longer than males.**
- Fertilisation is internal and development may be direct (the young ones resemble the adult) or indirect.

**Examples :** *Ascaris* (Round Worm),  
*Wuchereria* (Filaria worm),  
*Ancylostoma* (Hookworm).

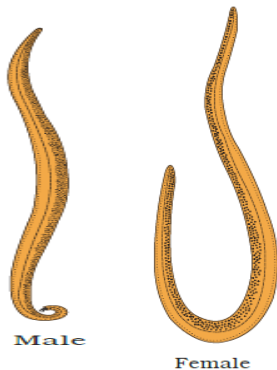

- *Nereis*, an aquatic form, is dioecious, but earthworms and leeches are monoecious.
- Reproduction is sexual.

**Examples :**

*Nereis*,

*Pheretima* (Earthworm)

*Hirudinaria* (Blood sucking leech).

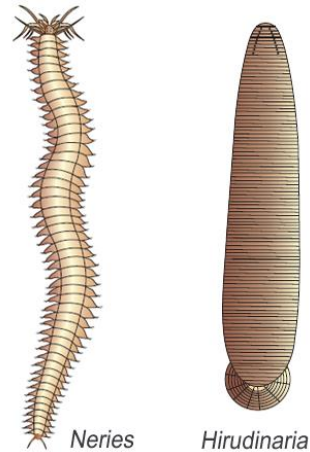

## 6. Phylum Annelida

- They may be aquatic (marine and fresh water) or terrestrial; free-living, and sometimes parasitic.
- They exhibit organ-system level of body organisation and bilateral symmetry.
- They are triploblastic, **metamerically segmented** and coelomate animals.
- Their body surface is distinctly marked out into **segments or metameres** and, hence, the phylum name Annelida (**Latin, annulus : little ring**)
- A closed circulatory system is present.
- They possess longitudinal and circular muscles which help in locomotion.
- Aquatic annelids like *Nereis* possess lateral appendages, **parapodia**, which help in swimming.
- **Nephridia** (sing. nephridium) help in osmoregulation and excretion.
- Neural system consists of paired ganglia connected by lateral nerves to a double ventral nerve cord.

## 7. Phylum Arthropoda

- This is **the largest phylum** of Animal kingdom which includes insects.
- Over **two-thirds** of all named species on earth are arthropods
- They have **organ-system level of organisation.**
- They are bilaterally symmetrical, triploblastic, segmented and coelomate animals.
- **The body of arthropods is covered by chitinous exoskeleton.**
- The body consists of head, thorax and abdomen.
- **They have jointed appendages (arthros-joint, poda-appendages).**
- Respiratory organs are gills, book gills, book lungs or tracheal system. (Insects)
- Circulatory system is of open type.
- Sensory organs like antennae, eyes (compound and simple), statocysts or balance organs are present.
- Excretion takes place **through malpighian tubules.**

- They are mostly dioecious. Fertilisation is usually internal. They are mostly oviparous. Development may be direct or indirect.

**Examples:**

**Economically important insects –**

- Apis (Honey bee),
- Bombyx (Silkworm),
- Laccifer (Lac insect)

**Vectors –**

- Anopheles, Culex and Aedes (Mosquitoes)

**Gregarious pest –**

- Locusta (Locust)

**Living fossil –**

- Limulus (King crab).

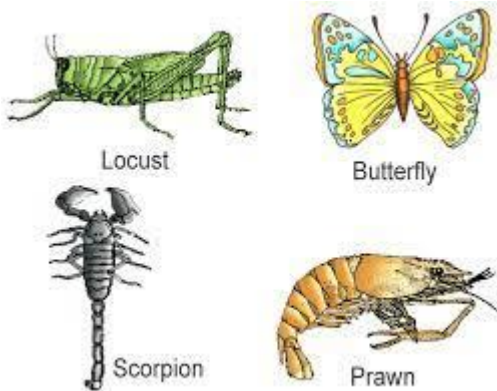

## **8. Phylum Mollusca**

- This is the **second largest animal phylum**
- Molluscs are terrestrial or aquatic (marine or fresh water)
- It has organ-system level of organisation.
- They are bilaterally symmetrical, triploblastic and coelomate animals.
- Body is covered by a **calcareous shell**
- Body is unsegmented with a distinct **head, muscular foot and visceral hump**. A soft and spongy layer of skin forms a **mantle** over the visceral hump. The space between the hump and the mantle is called **the mantle cavity in which feather like gills are present. They have respiratory and excretory functions.**
- The anterior head region has sensory tentacles.

- The mouth contains a file-like rasping organ **for feeding, called radula**
- They are usually dioecious and oviparous with indirect development

**Examples:**

- ***Pila* (Apple snail),**
- ***Pinctada* (Pearl oyster),**
- ***Sepia* (Cuttlefish),**
- ***Loligo* (Squid)**
- ***Octopus* (Devil fish)**
- ***Aplysia* (Seahare),**
- ***Dentalium* (Tusk shell)**
- ***Chaetopleura* (Chiton)**

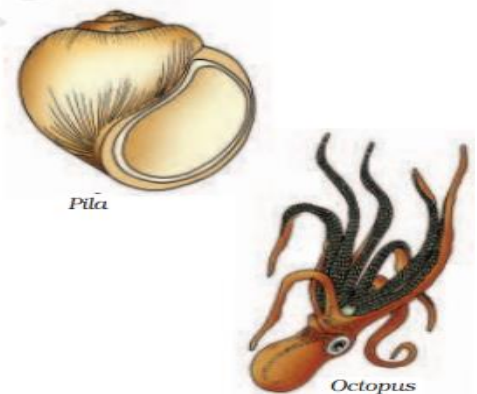

## **9. Phylum Echinodermata**

- These animals have an endoskeleton of calcareous ossicles and, hence, the name **Echinodermata (Spiny bodied)**
- All are marine with organ-system level of organisation.
- **The adult echinoderms are radially symmetrical but larvae are bilaterally symmetrical.**
- They are triploblastic and coelomate animals.
- Digestive system is complete with mouth on the lower (ventral) side and anus on the upper (dorsal) side.
- **The most distinctive feature of echinoderms is the presence of water vascular system**

**Functions of water vascular system**

- a)It helps in locomotion,
- b)It helps to capture and transport of food
- c)Helps in respiration.

- **An excretory system is absent.**
- Sexes are separate.
- Reproduction is sexual.
- Fertilisation is usually external.
- Development is indirect with free-swimming larva.

**Examples:**

**Asterias (Star fish),  
Echinus (Sea urchin),  
Antedon(Sea lily),  
Cucumaria (Sea cucumber) and  
Ophiura (Brittle star).**



*Balanoglossus*

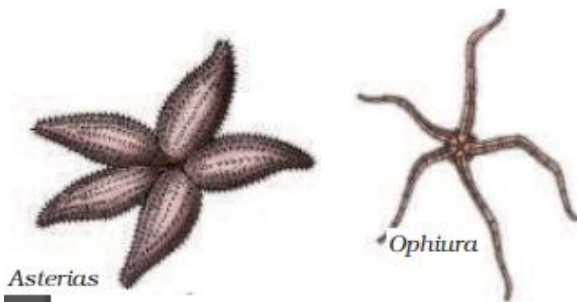

*Asterias*

*Ophiura*

## **10. Phylum Hemichordata**

- Hemichordata was earlier considered as a sub-phylum under phylum Chordata. But now it is placed as a separate phylum under non-chordata.
- Hemichordates have a rudimentary structure in the collar region called **stomochord**, a structure similar to notochord
- This phylum consists of a small group of **worm-like marine** animals .
- They have organ-system level of organisation.
- They are bilaterally symmetrical, triploblastic and coelomates animals.
- The body is cylindrical and is composed of an **anterior proboscis, a collar and a long trunk**
- Circulatory system is of open type.
- Respiration takes place through **gills**.
- Excretory organ is **proboscis gland**.
- Sexes are separate. Fertilisation is external. Development is indirect.

**Examples: Balanoglossus  
saccoglossus.**



# 11. Phylum Chordata

- Animals belonging to phylum Chordata are fundamentally characterised **by the presence of**
  - a **notochord**,
  - a **dorsal hollow nerve cord** and
  - paired pharyngeal gill slits**
- These are bilaterally symmetrical, triploblastic, coelomate with organ-system level of organisation.
- They possess a **post anal tail** and a closed circulatory system

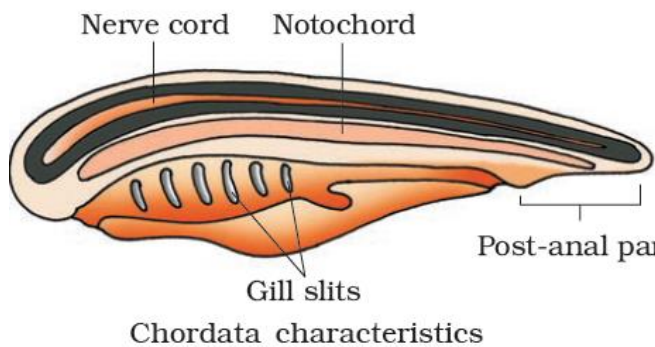

### Comparison between Chordates and Non chordates

S.No.	Chordates	Non-chordates
1.	Notochord present.	Notochord absent.
2.	Central nervous system is dorsal, hollow and single.	Central nervous system is ventral, solid and double.
3.	Pharynx perforated by gill slits.	Gill slits are absent.
4.	Heart is ventral.	Heart is dorsal (if present).
5.	A post-anal part (tail) is present.	Post-anal tail is absent.

- Phylum Chordata is divided into **three subphyla:**  
**A-Urochordata or Tunicata,**  
**B-Cephalochordata and**  
**C-Vertebrata.**

**Subphyla Urochordata and Cephalochordata are often referred to as protochordates**

### A) Subphylum Urochordata/Tunicata

- They are exclusively marine.

- In Urochordata, notochord is present **only in larval tail**

Examples ,

- Salpa,
- Ascidia .
- Doliolum;



### B) Subphylum Cephalochordata

- They are exclusively marine
- In Cephalochordata, notochord **extends from head to tail region and is persistent throughout their life**

Examples

**Branchiostoma (Amphioxus or Lancelet).**

### C) subphylum Vertebrata

- The members of subphylum Vertebrata possess notochord during the embryonic period. The notochord is replaced by a cartilaginous or bony vertebral column in the adult. Thus all vertebrates are chordates but all chordates are not vertebrates.**
- vertebrates have a ventral muscular heart with two, three or four chambers,
- kidneys for excretion and osmoregulation and paired appendages which may be fins or limbs
- The subphylum Vertebrata is further divided as follows

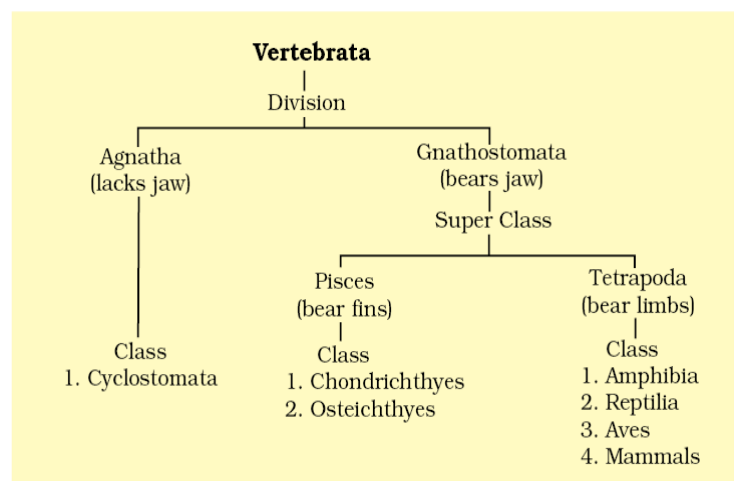

### Class Cyclostomata

- All living members of the class Cyclostomata are **ectoparasites on some fishes**.
- They have an elongated body bearing **6-15 pairs of gill slits** for respiration.
- Cyclostomes have a **sucking and circular mouth without jaws**
- Their body is devoid of scales and paired fins.
- Cranium and vertebral column are cartilaginous.
- Circulation is of closed type.
- **Cyclostomes are marine but migrate for spawning to fresh water. After spawning, within a few days, they die. Their larvae, after metamorphosis, return to the ocean.**

Examples:

*Petromyzon* (Lamprey), *Myxine* (Hagfish).



A jawless vertebrate - *Petromyzon*

### Super class Pisces

#### Class – Chondrichthyes

- They are marine animals with streamlined body and have **cartilaginous endoskeleton**
- Mouth is **located ventrally**.
- Notochord is persistent throughout life.
- Gill slits are separate and **without operculum** (gill cover).
- The skin is tough, containing minute **placoid scales**.
- Teeth are modified placoid scales which are **backwardly directed**.
- Their jaws are very powerful. These animals are **predaceous**.
- Due to the **absence of air bladder**, they have to swim constantly to avoid sinking
- Heart is **two-chambered** (one auricle and one ventricle).

- Some of them have electric organs (e.g., Torpedo) and some possess poison sting (e.g., Trygon).
- They are **cold-blooded (poikilothermous) animals, i.e., they lack the capacity to regulate their body temperature.**
- Sexes are separate.
- In males pelvic fins bear **claspers**. They have internal fertilisation and many of them are viviparous.

Examples:

*Scoliodon* (Dog fish),  
*Pristis* (Saw fish),  
*Carcharodon* (Great white shark),  
*Trygon* (Sting ray).

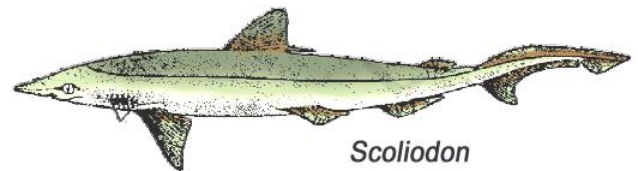

*Scoliodon*

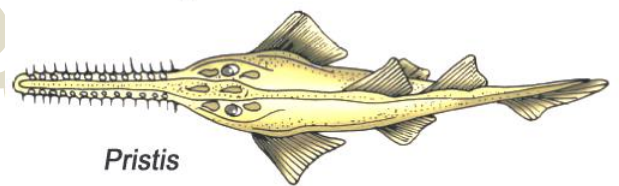

*Pristis*

#### Class – Osteichthyes

- It includes both marine and fresh water fishes with **bony endoskeleton**.
- Mouth is **mostly terminal**
- They have four pairs of gills which are covered by an operculum on each side.
- Skin is covered with **cycloid/ctenoid scales**.
- **Air bladder is present** which regulates buoyancy
- Heart is two chambered (one auricle and one ventricle).
- They are cold-blooded animals.
- Sexes are separate. Fertilisation is usually external. They are mostly oviparous and development is direct.

Examples:

Marine fish –

*Exocoetus* (Flying fish),

**Hippocampus (Sea horse)**

**Freshwater fish-**

- Labeo (Rohu),
- Catla (Katla),
- Clarias (Magur);

**Aquarium fish -**

- Betta (Fighting fish),
- Pterophyllum (Angel fish).

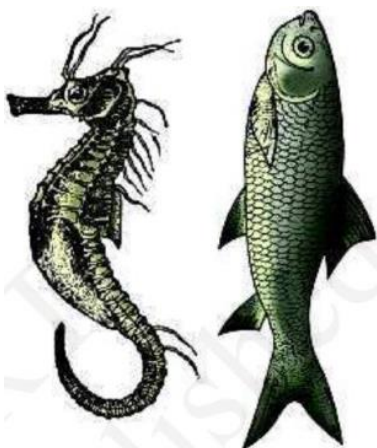

(a) (b)  
Examples of Bony fishes :  
(a) Hippocampus (b) Catla

**Difference between Chondrichthyes and Osteichthyes**

Class - Chondrichthyes	Class - Osteichthyes
They are marine animals	It includes both marine and fresh water fishes
They have cartilaginous endoskeleton	They have bony endoskeleton.
Mouth is located ventrally	Mouth is mostly terminal
Gill slits are separate and without operculum (gill cover).	They have four pairs of gills which are covered by an operculum on each side
The skin minute placoid scales	Skin is covered with cycloid/ctenoid scales
Air bladder absent	Air bladder is present
many of them are viviparous	They are mostly oviparous

**Class - Amphibia**

- As the name indicates (Gr., Amphi : dual, bios, life), amphibians can live in aquatic as well as terrestrial habitats
- Most of them have two pairs of limbs.
- **Body is divisible into head and trunk.** Tail may be present in some.
- The amphibian skin is moist (without scales).
- The eyes have eyelids.
- A tympanum represents the ear.
- Alimentary canal, urinary and reproductive tracts open into a common chamber called cloaca which opens to the exterior.
- Respiration is by gills, lungs and through skin.
- The heart is **three chambered** (two auricles and one ventricle).
- These are cold-blooded animals.
- Sexes are separate. Fertilisation is external. They are oviparous and development is indirect.

**Examples:**

- Bufo (Toad),**
- Rana (Frog),**
- Hyla (Tree frog),**
- Salamandra (Salamander),**
- Ichthyophis (Limless amphibia).**



(a) Salamandra



(b) Rana

### Class – Reptilia

- The class name refers to their creeping or crawling mode of locomotion (**Latin, repere or reptum, to creep or crawl**).
- They are mostly terrestrial animals and their body is covered by **dry and cornified skin, epidermal scales or scutes**
- They do not have external ear openings. Tympanum represents ear.
- Limbs, when present, are two pairs.
- Heart is usually three-chambered, **but four-chambered in crocodiles**.
- Reptiles are **poikilotherms**.
- Snakes and lizards shed their scales as skin cast.
- Sexes are separate. Fertilisation is internal.
- They are oviparous and development is direct.

Examples: **Chelone (Turtle),**

**Testudo (Tortoise),**

**Chameleon (Tree lizard),**

**Calotes (Garden lizard),**

**Crocodylus (Crocodile),**

**Alligator (Alligator).**

**Hemidactylus (Wall lizard),**

- **Poisonous snakes – Naja (Cobra),**  
**Bangarus (Krait),**  
**Vipera (Viper).**

### Class – Aves

- The characteristic features of Aves (birds) are the presence of feathers and most of them can fly except flightless birds (e.g., Ostrich).
- They possess beak
- The forelimbs are modified into wings. The hind limbs generally have scales and are modified for walking, swimming or clasp the tree branches. Skin is dry without glands except the oil gland at the base of the tail.

#### Flight adaptation of birds

- a) They possess beak
- b) The forelimbs are modified into wings
- c) Endoskeleton is fully ossified (bony) and the long bones are hollow with air cavities (**pneumatic**).

d) Air sacs connected to lungs supplement respiration.

- The digestive tract of birds has additional chambers, the crop and gizzard.
- Heart is completely four chambered.
- They are warm-blooded (homoiothermous) animals, i.e., they are able to maintain a constant body temperature.
- Respiration is by lungs. .
- Sexes are separate. Fertilisation is internal. They are oviparous and development is direct

Examples : **Corvus (Crow),**

**Columba (Pigeon),**

**Psittacula (Parrot),**

**Struthio Ostrich),**

**Pavo (Peacock),**

**Aptenodytes (Penguin),**

**Neophron (Vulture).**

### Class mammalia

- They are found in a variety of habitats – polar ice caps, deserts, mountains, forests, grasslands and dark caves. Some of them have adapted to fly( *Pteropus* (Flying fox) or live in water.
- **The most unique mammalian characteristic is the presence of milk producing glands (mammary glands) by which the young ones are nourished.**
- They have two pairs of limbs, adapted for walking, running, climbing, burrowing, swimming or flying The skin of mammals is unique in possessing hair.
- External ears or pinnae are present.
- Different types of teeth are present in the jaw.
- Heart is four chambered.
- They are homoiothermous.
- Respiration is by lungs.
- Sexes are separate and fertilisation is internal. They are viviparous with few exceptions and development is direct.



Examples :

**Oviparous-**

*Ornithorhynchus* (Platypus);

**Viviparous -**

*Macropus* (**Kangaroo**),

*Pteropus* (**Flying fox**),

*Camelus* (**Camel**),

*Macaca* (**Monkey**),

*Rattus* (**Rat**),

*Canis* (**Dog**),

*Felis*

(**Cat**),

*Elephas* (**Elephant**),

*Equus* (**Horse**),

*Delphinus* (**Common dolphin**),

*Balaenoptera* (**Blue whale**),

*Panthera tigris* (**Tiger**),

*Panthera leo* (**Lion**).

**Previous years question paper**

- Observe the picture and answer the questions.  
 (a) Identify the pictures. (HSE-Sept-2021)(1)  
 (b) How does this structure help the organism ?



- Mention a single word/term for the following :  
 (a) File like rasping organ in molluscs.  
 (b) Property of a living organism to emit light.  
 (c) Alternation of generation in Cnidarians.  
 (d) Hollow bones with air cavities.  
 (HSE-Sept-2021)(2)
- A student of Class XI, collected some specimens during the field trip conducted by the Science club. Help him to classify these animals to their respective phylum/class. (HSE-Sept-2021)(2)

**(Spongilla, Ctenoplasa, Laccifer, Calotes)**

- Figure (A) and (B) shows the fishes of two different classes. Identify and differentiate between them. (HSE-Sept-2021)(2)

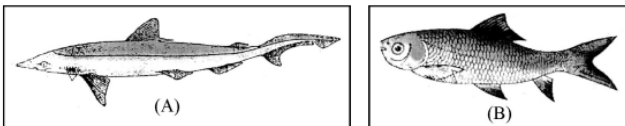

- Observe the table given below and replace (a), (b), (c) and (d) from those animals given in brackets. (HSE-Sept-2021)(2)

**(Hydra, Shark, Spongilla, Star fish)**

Asymmetry	Radial Symmetry	Bilateral Symmetry
Sycon	(a)	(b)
(c)	(d)	Cockroach

- Name the distinctive character (responsible for the group names) of the following animal :  
 (a) Ctenophora (HSE-Sept-2021)(3)  
 (b) Echinodermata  
 (c) Mammalia  
 (d) Chordata  
 (e) Annelida  
 (f) Arthropod

- Identify an oviparous mammals from the following examples (HSE Dec-2020)(1)  
 a)Pteropus b)Ornithorhynchus  
 c)Balaenoptera d)Equus
- Match the column A with column B

Column-A	Column-B
Platyhelminthes	Gill
Annelida	Malpighian Tubules
Arthropoda	Flame cells
Mollusca	Nephridia

(HSE Dec-2020)(2)

- Scoliodon, Pristis, Carcharodon and Trygon are the examples of class in vertebrata  
 a)Mention the class (HSE Dec-2020)(3)  
 b)List out any five characters of the class
- Identify the word pair applicable to phylum ctenophora. (HSE-March-2020)(1)  
 (a) Nephridia, Parapodia  
 (b) Comb plates, Bio luminiscence  
 (c) Polyp, Metagenesis  
 (d) Radula, Visceral hump
- Characteristics of certain animals are given. Arrange them under the 'Class' to which these animals belong. (HSE-March-2020)(2)  
 (i) Skin is moist without scales.  
 (ii) Body is covered by dry and cornified skin.  
 (iii) Shed the scales as skin cast.  
 (iv) Can live in aquatic as well as terrestrial habitats
- Observe the figures. (HSE-March-2020)(3)

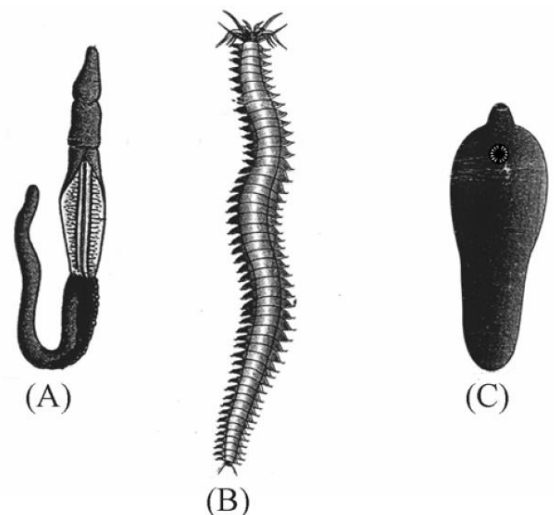

- Identify the organisms A, B & C.

- (b) Name the phylum to which each of them belong
13. Unlike bony fishes cartilage fishes are swim constantly to avoid sinking due to the -
- (a) Presence of pharyngeal gill slits
  - (b) Presence of air bladder
  - (c) Absence of pharyngeal gill slits
  - (d) Absence of air bladder (HSE-July-2019)(1)
14. The following are organs of certain animals :
- parapodia
  - Flame cells
  - proboscis gland
  - Comb plates
- (a) Select organs helps in excretion.
  - (b) Name the organism bearing these organs and write its phylum. (HSE-July-2019)(2)
15. Complete the Schematic diagram. (HSE-July-2019)(3)

18. "All vertebrates are chordates but all chordates are not vertebrates". Do you agree with this statement? Substantiate (HSE-March-2019)(2)
19. Find the odd one from each group. Justify your answer (HSE-March-2019)(2)

Cerebrum, Medulla, Mid brain, Thalamus, Pons, Corpora quadrigemina, Hypothalamus, Forebrain, Cerebellum, Hypothalamus, Hind brain, Brain.

20. Observe the figure of the given organism

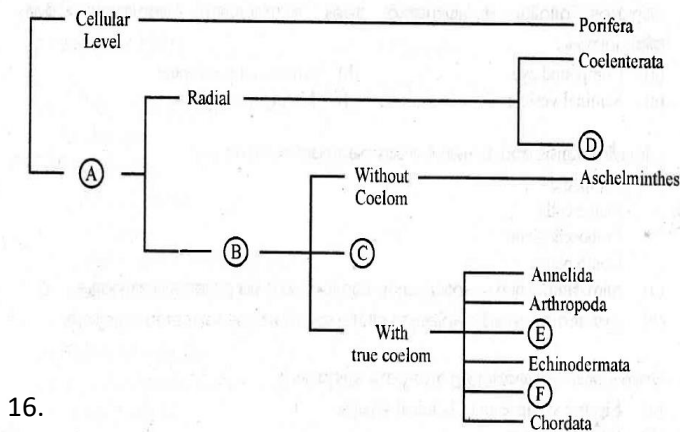

- a) Identify the organism
- b) Name and the class in which it belongs.
- c) Mention any two salient features of the class. (HSE-March-2019)(2)

- 16.
17. Complete the flowchart given below.

21. Note the relationship between two words and find a suitable word for the fourth Place
- a) Colenenterate : Radial symmetry
  - Platyhelminth : .....
  - b) Lizard : Poikilthermous
  - Crow : ..... (HSE-Model-2019)(1)

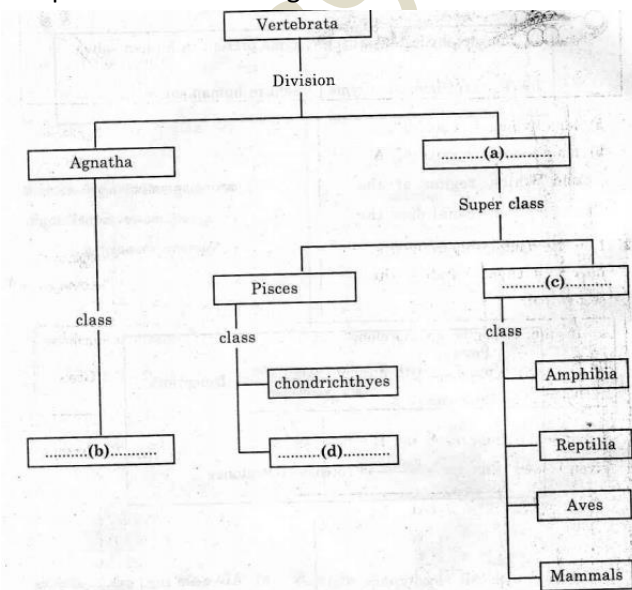

(HSE-March-2019)(2)

22. Which of the following animal exhibit metagenesis?  
Ascaris, Obelia, Earthworm, Crab (HSE-Model-2019)(1)
23. Who am I? (HSE-Model-2019)(2)
- 1 live in sea
  - 2 respire through gills
  - 3 excrete by proboscis gland
  - 4 My body consists of proboscis, collar and trunk.
- a) Identify the phylum.
  - b) Give one example from the phylum
24. From a fish market, you got a fish, on a close watching your friend says it is a cartilaginous fish.
- a) Which characters helped him to identify it as a cartilaginous fish (any four characters) ?
  - b) Name the class it belongs

(HSE-Model-2019)(2)

25. Note the relation in the first pair and then complete the second pair. (HSE-Aug-2018)(1)

<i>Fasciola</i>	:	Liver fluke
<i>Taenia</i>	:	.....?.....

26. Find out the odd one and justify your answer  
 Saw Fish, Jelly fish, flying fish,  
 Angel Fish, Dog Fish (HSE-Aug-2018)(2)  
 Name of certain animals are given below. Write the phylum of each animal. (HSE-Aug-2018)(2)  
 a) Pila  
 b) Pleurobrachia  
 c) Nereis  
 d) Balanoglossus

27. Observe the diagram showing the characteristics of a phylum (HSE-Aug-2018)(3)

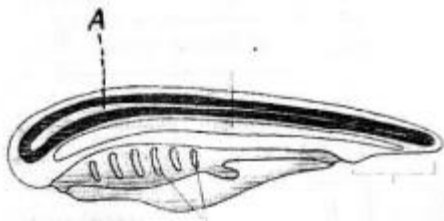

a) Identify the Phylum  
 b) Name the Part labeled 'A'  
 c) Point out the three fundamental characters of the phylum.

28. Note the relationship in the first pair and then complete the second pair. (HSE-March 2018) (1)  
 Osteichthyes : Cycloid scales  
 Chondrichthyes : .....

29. Arrange the following terms under two headings based on symmetry (HSE-March 2018) (2)  
 Arthropods, Ctenophores, Molluscs, Coelenterates

30. a) A table showing examples of vertebrates given below. But some of the examples are wrongly given. Identify and rearrange it. (HSE-March 2018) (3)

Pisces	Amphibia	Reptilia	Aves	Mammalia
Dog fish	Frog	Vulture	Penguin	Alligator
Blue whale	Rohu	Tortoise	Salamander	Flying fox

b) Which of the above mentioned class is characterised by the presence of pneumatic bone ?

31. Find out the pseudocoelomate animal from the following : (HSE-Model 2018) (1)  
 Tapeworm, hook worm, Earth worm, Honey bee

32. a) Classify the given organisms under the heading Poikilothermous and homiothermous.  
 Rat, Frog, Dog fish, Ostrich

b) Define the terms poikilotherms and homiothermous (HSE-Model 2018) (2)

33. a) Identify the organism. (HSE-Model 2018) (2)



a) Name the class in which it belongs to ?  
 b) Write any one characteristic feature of the class

34. Match the items in column B and C with A (HSE-March-2017)(3)

A	B	C
Phylum/Class	Common example	Unique features
Pisces	Aedes	Presence of hair
Mammalia	Leech	Open circulatory system
Arthropoda	Felis	Presence of 2 chambered heart
	Scoliodon	Presence of Nephridia



**OR**

35. Features of different phyla/class are given below. Identify the phylum/class and give examples of each group

(HSE-March-2017)(3)

- a) Body is covered by scales, heart is 3 or 4 chambered. They respire through lungs
- b) They are exclusively marine, commonly called sea walnuts and show Bioluminescence
- c) Body is divided into Proboscis, collar and trunk. They have pen circulatory system and presence of proboscis gland.

36. Among the different phyla of animals.....have psudocoelom

(HSE-March-2017)(1)

37. Categorize the following animal under radial symmetry and bilateral symmetry

(HSE-March-2017)(2)

Physalia, Tapeworm, Fasciola, Adamsia

38. Characters of a marine invertebrate is given below

- Spiny skinned body
- Presence of water vascular system

- a) Identify and write the phylum?
- b) Write any two functions of water vascular system among them

(HSE-Sept-2016)(2)

39. a) Identify the cell given in the diagram



- b) Mention the name of animal phylum based on this cell

(HSE-Sept-2016)(1)

40. Two examples of fishes are given below

- Scoliodon (dog fish)

- Exocoetus (Flying fish)

a) Place them in 2 distinct class ?

b) Differentiate the above class based on 2 important characters ? (HSE-Sept-2016)(3)

41. The characteristic feature of an invertebrate animal is given

“The phylum include the comb jellies, also called walnuts, they are noted for their bioluminescence and comb plate”

Identify the phylum ? (HSE-March-2016)(1)

42. Fill in the blanks with appropriate words

Osteichthyes : cycloid scale

Chondrichthyes:.....

(HSE-March-2016)(1)

43. Name the phyla in which the following cells or structures or organs are present

- a) Radula
- b) Cnidoblast
- c) Pneumatic bone
- d) Proboscis gland

(HSE-March-2016)(2)

44. The following diagram shows the characteristic feature of a phylum

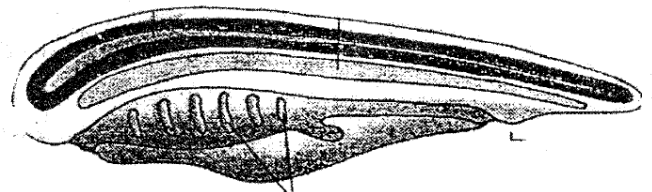

- a) Identify the phylum
- b) Mention four salient features of this phylum?

(HSE-March-2016)(2)

45. Observe the following features of animal and answer the following questions

(HSE September-2015) (1)

- Moist skin
- Hooks and suckers
- Pneumatic bones
- Dry and non glandular skin
- Metamerism

- a) Select the flight adaptation of birds
- b) Select the amphibious adaptations of birds

46. Assign the following features of animals given in the column A to the most appropriate animal phylum given in the column B  
(HSE September-2015) (2)

Column A	Column B
a)Metamerism	i)Ctenophora
b)spiny exoskeleton	ii)Platyhelminthes
c)comp plate	iii)annelida
d)flame cell	iv)cnidaria
	v)Echinodermata
	vi)Porifera
	vii)Hemichordata

47. The diagram sketch given below represents hypothetical chordate  
(HSE September-2015)(3)

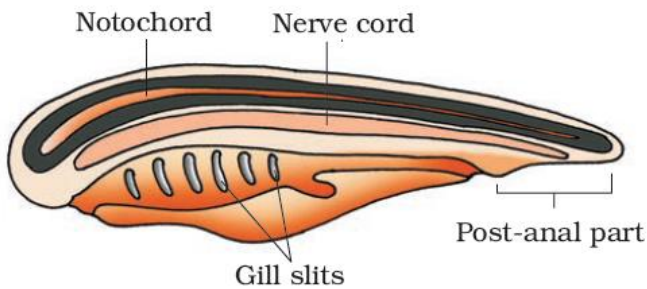

- a. If you find any mistake in the labelled part, copy the diagram and make necessary correction in the labelling
- b. Based on any two labelled parts in the diagram, mention how this phylum differs from non chordates

48. Prawns and insects are included in the phylum arthropoda while they have different habit and habitat. Justify your answer?  
(HSE march-2015)(1)

49. Figure (X) and (Y) are the fish of two different classes. Identify them and differentiate between these classes  
(HSE march-2015)(2)

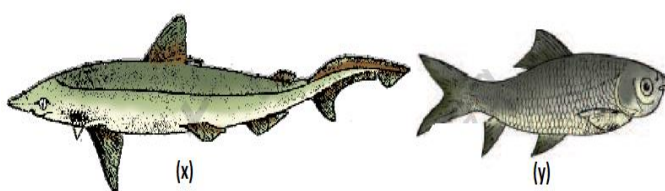

- 50. Birds are well adapted for flying. Give any 3 of such adaptations? (HSE march-2015)(3)
- 51. All vertebrates are chordates but all chordates are not vertebrates. Justify this statement with an example? (HSE march-2015)(3)
- 52. Find the relationship between the first pair and fill in the blank (HSE august-2014)(1)  
Salamander :amphibia  
Chameleon :.....
- 53. In your practical, the class teacher brought the following preserved animals  
a)Balanoglossus b)pila  
c)tapeworm d)Physalia  
Identify the phylum of each animal and select the distinguishing character of each phylum from the following table (HSE august-2014)(4)

  - 1)Presence of comp plate
  - 2)presence of flame cell
  - 3)presence of radula
  - 4)presence of malpighian tubule
  - 5)Presence of probosis gland
  - 6)Presence of cnidocyte
  - 7)Presence of notochord.

- 54. "all vertebrates are chordates but all chordates are not vertebrates". Evaluate and substantiate the statement?  
(HSE march-2014)(2)
- 55. Name the distinctive character (Responsible for their names) of the following animal groups (HSE march-2014)(3)  
a)Cnidaria b)Arthropoda  
c)Porifera d)Annelida  
e)chordate f)Ctenophora
- 56. Your biology teacher exhibited a laboratory specimen in the classroom. Based on which feature will you distinguish it as chordate or a nonchordate? (HSE march-2014)(3)
- 57. Observing starfish in a marine aquarium your friend commented that it is a lower invertebrate without distinct head, eyes and legs.Do you agree with him? Evaluate his statement with reasons?

- (HSE october-2013)(2)
58. The following are the key characteristics of an animal group (HSE october-2013)(2)
- Circular and sucking mouth without jaws
  - Fish like body without scales and paired fins
- a) Name the class in which this animal belongs
- b) Give two examples from this class.
59. Frogs, salamanders, Tortoises and crocodiles are seen in both water and land. but they are classified into two different classes of the phylum vertebrate. Evaluate this classification comparing salient features of each class? (HSE october-2013)(2)
60. a. Pick out the acoelomate organism from the following: (HSE march-2013)(3)
- i) Round worm ii) Hook worm  
iii) Filarial worm iv) Tape worm
- b. Name the phylum to which it belongs
- c. Mention its mode of nutrition
- d. What is the coelomic condition of other organisms?  
Substantiate your answer
61. During a sea shore visit, a student collected two organisms. Observing the morphology, it is clear that the organisms are radially symmetrical. One of them shows bioluminescence (HSE march-2013)(3)
- a) To which phylum does this organism belong?
- b) Identify the possible phyla to which the other organism can be included
- c) Which distinctive feature of this organism will help you to categorize it into a particular phylum?
62. Fill in the blanks (HSE september-2012)(1)
- Coelomate: arthropoda ;  
Pseudocoelomate :.....
63. Is it possible to compare the water vascular system of phylum echinodermata to circulatory system of man in some aspects? Justify your answer? (HSE september-2012)(2)

64. Organisms of this phylum are radially symmetrical, triploblastic, and coelomate with a complete digestive system (HSE september-2012)(2)
- a) Identify this phylum
- b) Give an example for this phylum
- c) What are the distinctive features of this phylum?
65. Find the relationship between given words and suggest the suitable word for the fourth place (HSE march-2012)(1)
- a) Annelida : Nephridia  
Arthropoda :.....
- b) Osteichthyes: cycloid scales  
Chondrichthyes:.....
66. Match the column I with II. (HSE march-2012)(2)

Column I	Column II
a) Cold blooded animal	Platypus
b) Living fossil	Sea cucumber
c) Egg laying mammal	Limulus
d) Water vascular system	Shark
	peacock
	earthworm

67. The following diagram shows the characteristics of a phylum (HSE march-2012)(3)

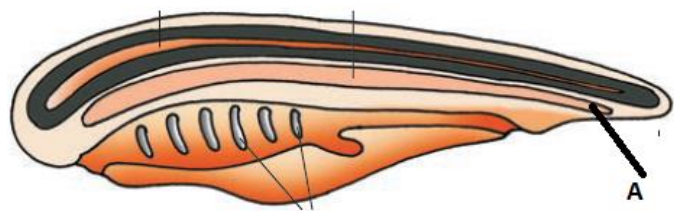

- a) Identify the phylum
- b) Label A in the diagram
- c) Mention four salient features of the phylum
68. Complete the column using the appropriate phylum, distinctive features and excretory organs (HSE march-2011)(3)

Phylum	Distinctive features	Excretory organs
Platyhelminthes	a).....	b).....
Arthropoda	c).....	Malpighian tubule
d).....	Body segmentation like rings	e).....
f).....	Water vascular system	Excretory system absent

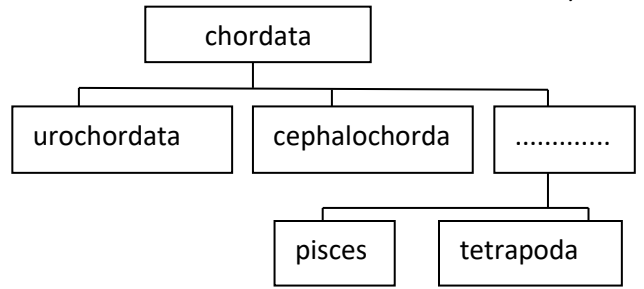

- b. write any two fundamental characters of the phylum chordate
- c. Classify tetrapoda into classes. (HSE march-2009)(3)

69. Figure A and B are the fishes of two different classes. Identify and differentiate between these classes (HSE march-2011)(3)

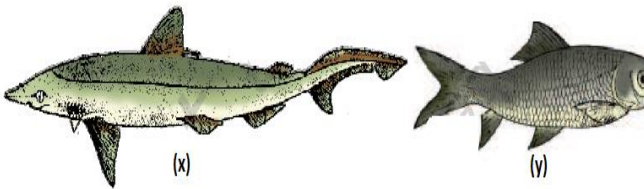

70. Classify the organism below based on segmentation (HSE march-2010)(3)  
 a)ascaris b)taenia c)fasciola d)wuchereria  
 e)neries f)Pheretima

71. Match Column B and C with Column A (HSE march-2010)(3)

A	B	C
Reptilia	Feathers	Psittacula
Aves	Mammary glands	Hyla
Mammalia	Parapodia	Chelone
	Scales	Panthera
	Tube feet	Scoliodon

72. Observe the table Given below and fill the blank columns a, b, c and d from the animals given in the brackets (HSE march-2009)(3)  
 (Hydra, shark, spongilla, Obelia)

Asymmetry	Radial symmetry	Bilateral symmetry
Sycon	.....(a).....	.....(b).....
.....(c).....	.....(d).....	cockroach

73. a. Fill and complete the chart given below