

**A
R
T
I
L
L
E
R
Y**



TRENDS



**F
e
b
r
u
a
r
y**

Artillery's night
hand is. . .

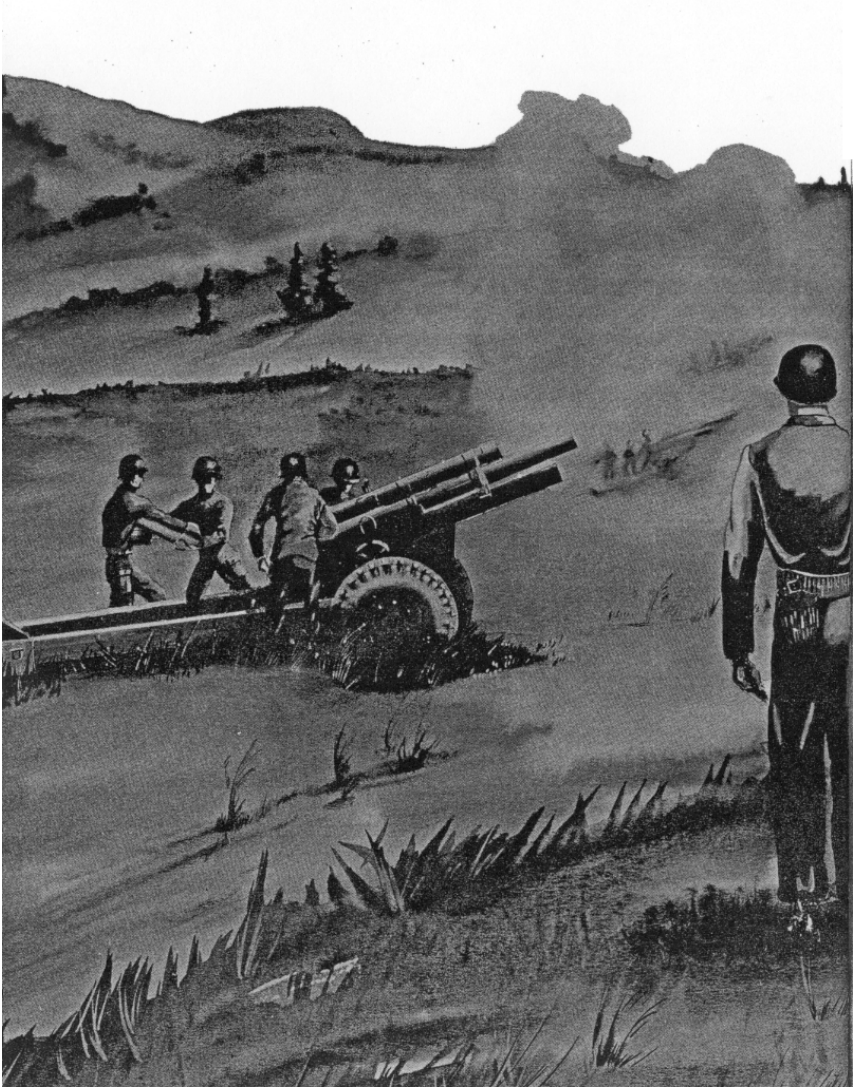

ARTILLERY

TRENDS

February 1962

Instructional Aid Number 21

US Army Artillery and Missile School

● ARTICLES

Track—80	4
The sergeant trainer—Missiles in the Classroom	7
New Division Artillery Aviation	12
Airborne Div Arty Reorganization.	19
Long-range considerations—Missile Fire Planning.	28
From group to battalion—Redstone Reorganized	32
FDC speed, simplicity, sureness—Stick and Fan Status	39
Infantry, Armor, Mechanized— Battalion Communication Systems.	44
Progress Report: FADAC	54
PADA concept for—Little John.	57

● NEWSNOTES

News of, for, about the Artillery World.	60
--	----

● RESIDENT COURSES

Current Resident Course Schedule	64
--	----

● TRAINING LITERATURE

Status of Training Literature	67
---	----

● SUBJECT INDEX

Subject Index for 1961 ARTILLERY TRENDS	71
---	----

● COVER

This issue of ARTILLERY TRENDS takes to the air to discuss the new division artillery aviation (p. 12) and the airborne division artillery (p. 19); and from this lofty vantage point looks back to survey its own instructional efforts of 1961 (Subject Index, p. 71).

Something for from the Non-Resident

U.S. Army Artillery

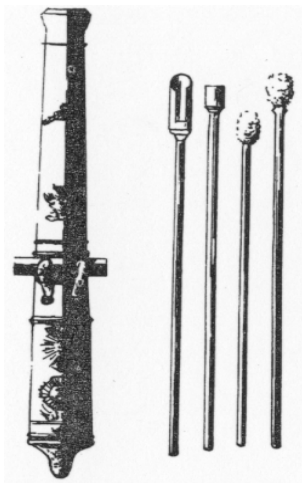

- from oldest ●
- from jungle ●
- from survey ●
- from 105 ●

for the **INDIVIDUAL**

ENROLL

In the Field Artillery Extension Course Program

OPEN TO

US Army Active Duty Personnel
US Army National Guardsmen
US Army Reservists

FOR

Refresher Courses
Career Courses
Specialist Courses

SEE

Your 1961-62 Catalog, "Extension Courses for Artillery" for detailed information concerning subcourses available, their scope, and enrollment procedures, or write to:

COMMANDANT
US Army Artillery and Missile School
Nonresident Instruction Department
ATTN: Extension Course Division
Fort Sill, Oklahoma

All Artillery Instruction Department and Missile School

- to newest
- to mountain
- to salvo
- to Pershing

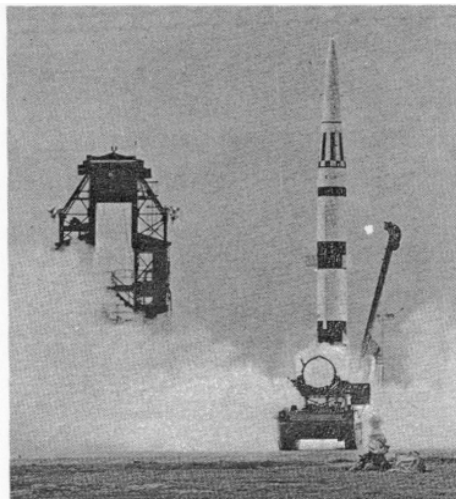

for UNITS, SECTIONS, STAFFS

SEND FOR

classes and subcourse materials from the
Reserve Component Division

OPEN TO

US Army Active and Reserve Units (at NO COST)
US Army National Guard Units (on a reimbursable basis)

FOR

Unit Training Classes
Section Training Classes
Staff Training Classes

SEE

Your new "Catalog of Instructional Material" (Period of 1 July 62-30
June 63) for detailed information, or write to:

COMMANDANT

US Army Artillery and Missile School
Nonresident Instruction Department
ATTN: Reserve Component Division (AKPSINI/RC-F2)
Fort Sill, Oklahoma

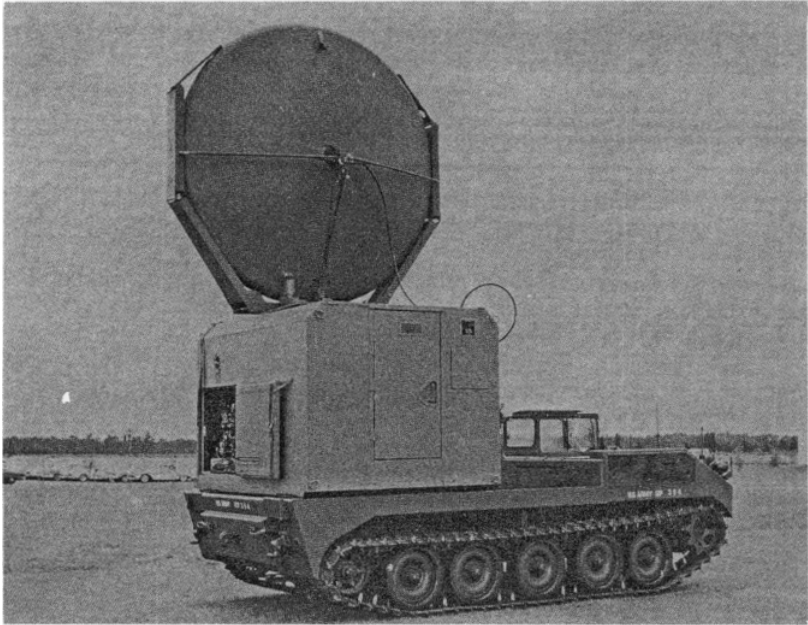

TRACK-80

Captain Henry E. Callaghan
Communication/Electronics Department

Early in the development of the Pershing missile system, it was realized that a requirement existed for communication equipment which would have the reliability and transportability of the rest of the missile system. As the concepts for the tactical employment of the system were developed, it became apparent that this communication equipment would have to operate at ranges up to 100 miles with a high degree of reliability.

To meet these requirements, the Collins Radio Company designed and manufactured the radio set AN/TRC-80. The AN/TRC-80 is a completely self-contained, portable, tropospheric scatter, radio communication terminal. It provides one duplex voice channel and one half-duplex teletype channel for point-to-point communication with an operational reliability of 99.9 percent at distances up to 100 miles. The AN/TRC-80 is equipped

with a highly directional, air-inflatable, parabolic antenna and operates in the 4.4- to 5-kilomegacycle band with 333 operating frequencies.

The requirement for a high degree of reliability dictated the decision to adopt the tropospheric scatter mode of propagation. This type of communication is immune to adverse atmospheric weather conditions and ionospheric disturbances and is difficult to jam by conventional means. An additional aspect of this method of propagation is that it is extremely difficult for enemy direction-finding equipment to locate this type of radio set.

Another requirement of this communication system is that it be capable of rapid emplacement by a small crew with a minimum of tools and auxiliary equipment. To meet this requirement, the AN/TRC-80 is designed to be set up for operation in 10 minutes, by a two-man crew, without the aid of any tools or auxiliary equipment.

The requirement for a completely self-contained unit included not only the complete radio set but also the primary power source. To meet this requirement, a gasoline engine-generator is housed in the shelter with the radio. This engine-generator is a 120-208 volt, 3-phase, 400-cycles per second, 4-wire power source rated at 10 kilowatts. During operation, a door is opened in the side of the shelter, and the engine-generator is moved out of the shelter on rails and operated in this position (fig 1). Since there is no requirement for separate loading of a large engine-generator, the entire terminal can be moved as one 4,600-pound load.



Figure 1. Final check of AN/TRC-80 prior to operation.

Although the AN/TRC-80 can be transported by helicopter, the primary means of movement is the XM474 tracked vehicle. This is the same vehicle that is used to transport the other elements of the Pershing missile platoon.

In the radio set AN/TRC-80, the field artillery has a radio system which meets the reliability, transportability, and range requirements of the Pershing missile system; it can accompany the Pershing any place the rest of the system can go and can fulfill the Pershing communication requirements upon reaching the missile site. This is the first item of communication equipment designed as a part of a field artillery weapons system, and, as such, it fulfills the requirements of the system more completely than any other communication equipment presently in the signal inventory.

GEM FOR THE 155-MM HOWITZER SECTION

If you've had problems laying out the necessary holes for your 155-mm towed howitzer before it comes into position, try the following method for quick, accurate orientation of high angle pit, trail holes, etc.

First, prepare a board as in figure 6. Then place marks on a length of nylon cord at 1) 30 inches from the end, 2) 53 inches from the end, 3) 78 inches from the end, and 4) 14 feet, 6 inches from the end.

USING THE BOARD

Place the board on the ground in the general direction of fire, and, using line "d" and a compass, orient the board on the azimuth of fire.

Stake the board to the ground (a wooden, brass, or aluminum stake is preferable, since the compass is being used) through the stake hole at point "g". Secure the nylon cord to the stake.

Holding the cord at the 30-inch mark, superimpose over line "a". Pull taut and mark the ground. Repeat this on the other side of the board. This line represents the inside position of the wheel blocks, if used. Next, use line "d" and the 2nd (53") and the 3rd (78") marks on the cord to establish the boundaries of the high angle pit. The pit should be wide enough to accommodate the traverse limits of the howitzer.

Finally, place the cord over line "b", and mark the ground (at the 14'6" mark) while swinging the cord to a position over line "c". This outlines the center line of the left trail spade hole. Add approximately eight inches above and below the center line to complete the left trail spade outline. Repeat this process on the other side of the board (lines "e" to "f") for the outline of the right trail spade hole.

When a 155mm towed howitzer is brought in over holes dug from this board, it should be ready to drop in and begin laying procedures. And you have saved valuable time. Figure on page 11.

—submitted by SFC Thomas E. Hutton
"B" Btry, 1st How Bn
79th Artillery

the sergeant trainer . . .

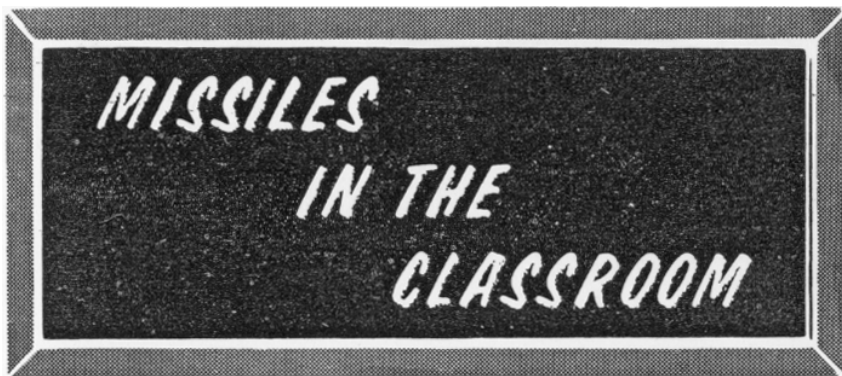

Captain Bruce Beal
Guided Missile Department

Trainers have been added to the equipment list of the Sergeant missile system. The merit of missile system trainers has been proved by the addition of trainers to the Corporal, Redstone, and Lacrosse systems. These trainers have saved money and training time by substituting rugged, relatively inexpensive components for the sensitive, costly tactical missile equipment components. Indirectly, missile trainers have saved even larger sums because the tactical missile need not be designed to withstand constant training use.

To be effective, trainers used by TOE units should be realistic and rugged and should not be a logistic burden. These requirements are met by trainer missile 3G52, which is issued to each Sergeant missile battery. The 3G52 consists of a trainer missile, missile section containers, two suitcase-size instructor consoles, and tactical missile transporters. To the Sergeant missile battery personnel, the trainer missile appears and responds exactly as would a tactical missile. The firing set operator, using the trainer missile, enters the firing problem into the computer and conducts the automatic countdown as he would during an actual fire mission. Survey also follows standard procedures. Although these operations are performed in the firing section, the personnel of the missile test section also use the missile trainer in operations conducted at the organizational maintenance test station (OMTS).

The OMTS checks out the 3G52 trainer missile in its containers. If a "failure" is detected, the trainer missile is taken inside the OMTS, and the "malfunctioned" assembly is replaced. Physically, the trainer assemblies and cable harnesses are identical in appearance to those of the tactical missile and therefore satisfy the training requirements of the OMTS operators in assembly replacement procedures.

To fulfill the objectives of the trainer missile, instructor consoles are cabled into the firing set and OMTS, permitting malfunctions to be

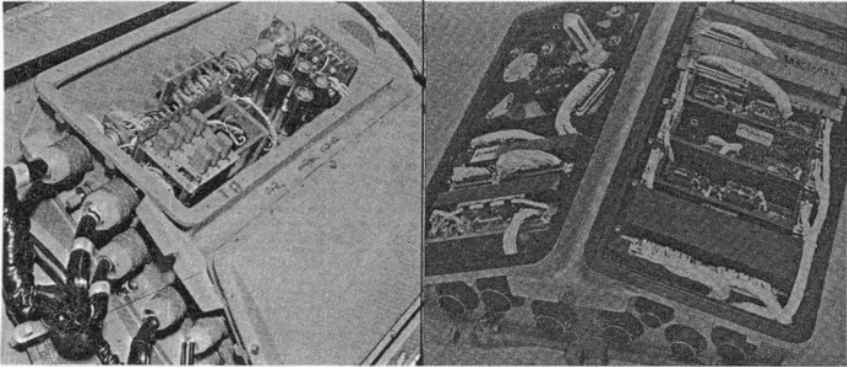

Figure 2. Control assembly, guidance section, Sergeant missile, with 3G52 trainer at left and tactical assembly at right.

inserted into the trainer. These consoles will duplicate any failure indication that could occur in a tactical missile. The instructor consoles energize latching relays, thereby causing a failure indication to appear in the firing set or in the OMTS. Standard tactical operator procedures are then followed to locate and correct the "malfunctioned" assembly.

Should the firing set operator detect a simulated malfunction in the missile guidance section, the guidance section can be removed and taken to the OMTS for malfunction isolation. Once the malfunction is located, the assembly can be replaced with an operable item. Any simulated problem inserted in a trainer missile assembly will remain in that assembly until removed by the instructor using his console.

To complete the training capability of the trainer missile, two additional consoles are required, one for the firing set and the other for the OMTS. These consoles provide malfunction indications in the stations during their respective self tests and also provide malfunction indications of the stations themselves during countdown and checkout respectively.

A SECOND TYPE OF TRAINER

The second type of trainer, the Sergeant ground support equipment (GSE) trainer 3G100, is essentially a classroom trainer. The 3G100 will be used at Fort Sill for training of specialists by the US Army Artillery and Missile School and for advanced individual training (AIT) by the 1st Field Artillery Missile Brigade. The Sergeant ground support equipment is rugged and reliable, but would receive more extensive use by students than by crewmen in a tactical unit, which would cause increased wear and possible lengthy down-time. And since nonoperating equipment cannot be tolerated in the Sergeant training program, it is necessary that students use a simple, easily maintainable training device.

Physically, the GSE trainer duplicates the interior of the firing set (fig 3) and OMTS (fig 4), with one exception. The walls of the GSE



Figure 3. Firing set, Sergeant missile, with 3G100 GSE trainer (instructor console in foreground) at left and tactical set (inside van) at right.

trainer can be opened for lectures and practical demonstrations. When the trainer is used in this manner, an instructor can demonstrate the sequence of operation of the firing set and OMTS to large groups. This cannot be done when using the tactical equipment.

Functionally, the GSE trainer operates exactly as its tactical counterpart. Complete checkout procedures in the OMTS trainer and complete countdown procedures in the firing set trainer can be conducted. However, electrically, there is little similarity between tactical and trainer

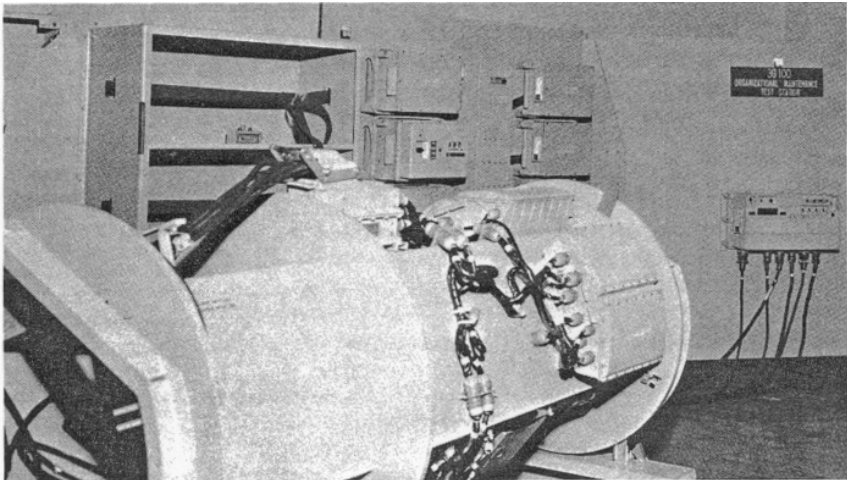

Figure 4. Ground support equipment trainer 3G100, OMTS and simulated missile.

ground support equipment. The majority of the electrical components are centrally located and greatly simplified, providing durability and ease of maintenance. It is less difficult to detect and replace a malfunctioned plug-in relay of the trainer than a malfunctioned computer memory board of the tactical firing set.

The GSE trainer has instructor consoles to insert simulated faults into the trainer, duplicating all the possible fault indications in the tactical equipment. If a malfunction indication has appeared in the OMTS portion of the GSE trainer, the student can remove and replace the indicated assemblies not only in the OMTS but also in a simplified trainer guidance section. This permits the student to learn assembly location and methods of replacement. The OMTS can operate with or without the training guidance section, thus adding to the flexibility of the GSE trainer.

A third type of Sergeant missile trainer, the cutaway missile motor 3G124 (fig 5), is also a classroom trainer. This trainer shows various

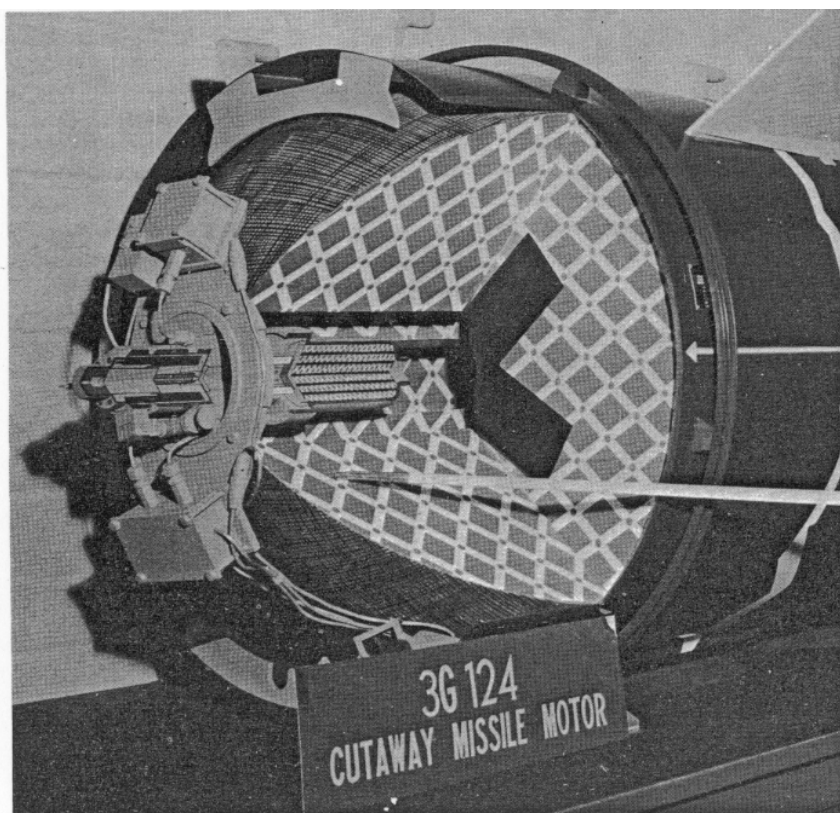
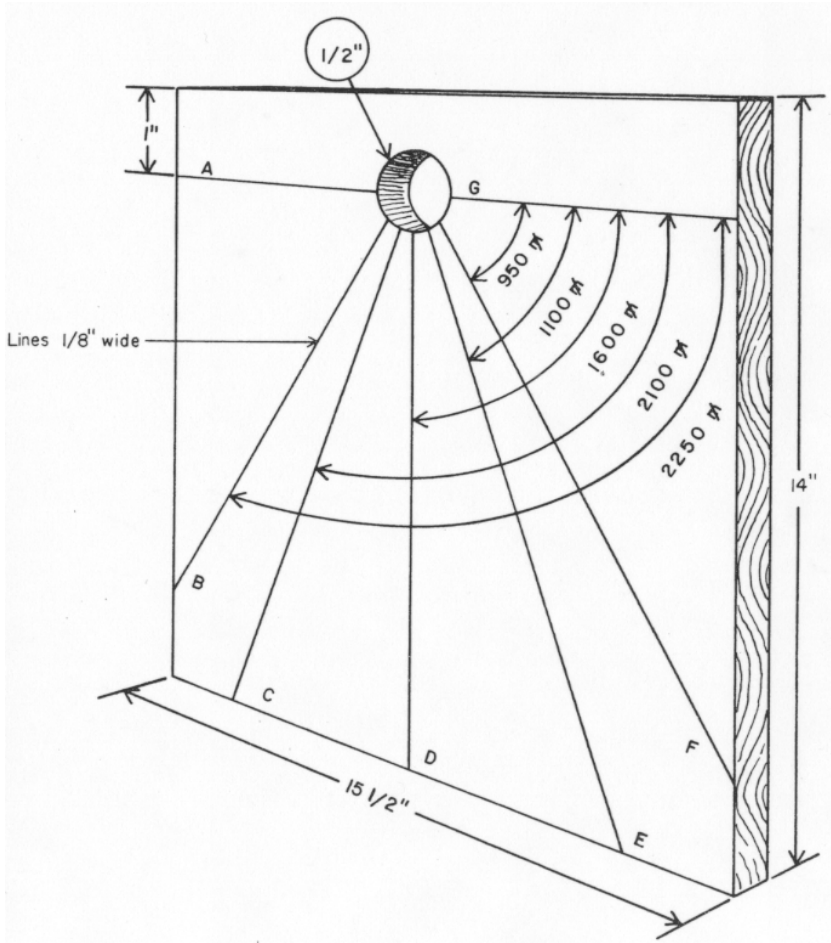

Figure 5. Cutaway missile motor 3G124.

features of the missile motor, such as the fins, nozzle, propellant, and ignition system.

The Sergeant missile trainer 3G52, ground support equipment trainer 3G100, and cutaway missile motor 3G124 fill a definite need. The cost of maintaining trainers is a small fraction of that required for tactical equipment, and trainers themselves are much less costly than the tactical equipment. The major advantage and specific purpose of these trainers is that they not only save time and money but also provide realistic training for the soldier.



Explanation: page 6.

Figure 6. Orientation board for section position holes.



Captain W. F. Dixon
Tactics/Combined Arms Department

The new divisions will provide artillery with organic aviation in the form of an aviation section in the headquarters and headquarters battery, division artillery, of the infantry, armored, and mechanized divisions.

The section is composed of 12 warrant officers, 15 enlisted men, 10 light observation helicopters, 2 utility fixed-wing aircraft, and other necessary equipment as listed in detail in draft TOE 6-302E.

CAPABILITIES

The primary missions of all organic or assigned artillery aircraft are observation, reconnaissance, surveillance, and fire adjustment. The aircraft must be capable of performing these missions in daylight and, to a limited extent, at night. The night limitations are the result of peculiarities of aircraft instrumentation.

The light observation helicopter (LOH) is being designed as simply as possible to reduce maintenance requirements. Reducing the maintenance requirements will permit assignment of this aircraft at unit level. However, to accomplish this, only basic instruments which provide for daytime visual flight will be installed. The helicopter is basically an unstable air vehicle. It has an oval plexiglass bubble that creates distortion of vision. At night, without proper instruments to refer to, vertigo (dizziness) becomes an extreme hazard.

A second capability is the transportation of supplies and equipment. There are again limitations of design. The LOH is designed for a pilot and an observer. There is no provision for sling loads or cargo-lift ability. However, without the observer, it is feasible to transport small arms, ammunition, C-rations, clothing, and other items of equipment which are not bulky or overweight.

The two utility aircraft (L-20's) can lift 500-pound bundles under each wing for para-drop or free fall, or carry 1,200-pounds of cargo internally.

Although aeromedical evacuation will normally be performed by a medical service corps unit attached to the division, there may be occasions when aircraft from the aviation section will be at the scene and can expedite the movement of a casualty back to the division clearing station. All aircraft in the aviation section can transport litter or ambulatory patients.

Aircraft can be used for limited battle area illumination. Flares dropped by helicopters or fixed-wing planes provide sufficient light for aimed fire, surveillance under conditions approximating daylight, movement of troops and vehicles, minefield operations, evacuation of casualties, and resupply. Flares can be used effectively to silhouette and harass the

enemy and discourage infiltration. Observation aircraft are capable of continuous flare illumination of one-half hour duration per sortie; utility aircraft—one and one-half hours per sortie.

The limitations of night operation, discussed above, restrict the employment of this section for illumination missions; however, illumination missions will be assigned depending on the availability of aircraft and the schedule of activities for the following day. If an illumination mission at night hinders the proper maintenance and therefore precludes daytime operations, the illumination may have to be obtained in some other manner.

The technique of dropping flares is an exacting one. Care must be exercised in determining the dropping point, since flares may be carried off-target by the wind. Initial flares should be dropped well beyond friendly elements until the direction, rate of drift, and altitude of burst have been established. The desired altitude of burst is that which utilizes the full burning time of the flare and still provides the desired intensity of illumination on the ground. If orientation for dropping the initial flare is inadequate, illuminating or white phosphorus orienting rounds may be fired to identify the initial drop point to the aircrew. Subsequent flares are adjusted by the ground observer. After initial adjustment, the aircrew can maintain continuous illumination from the light afforded by preceding flares without further orientation or control from the ground observer. Under unfavorable weather conditions however, with insufficient ground orientation, ground radar may be used to control successive flare delivery from the utility aircraft after initial adjustment by the ground observer. Communication with the ground observer must be maintained in this case.

Helicopters can be of invaluable assistance in survey. Without large scale maps, or when terrain or the tactical situation are such that the division artillery and artillery battalion survey parties are unable to extend survey control along the ground, a technique of survey employing rotary-wing aircraft may be used. This method (fig 7) requires a rotary-wing survey base established on the ground by division artillery survey parties. The aircraft then fly predetermined flight patterns, stopping over designated points to hover. Simultaneous instrument readings are taken on the aircraft at each helicopter hovering point (HHP) by the division artillery base and by units in the division area. The coordinates and height of each hovering point are determined from the division artillery base by using intersection and are transmitted at a later time directly to the batteries of the division artillery. Using the instrument readings taken at the battery and the coordinates of the hovering point, it is possible to establish location of battery centers with the computation of a simple three-point resection problem. Although direction can also be established through these resection computations, it is not always reliable, and therefore, batteries should follow up with an astronomical observation or should participate in simultaneous observation.

Survey data obtained by use of rotary-wing aircraft should be considered with caution. The reliability of data obtained by this technique

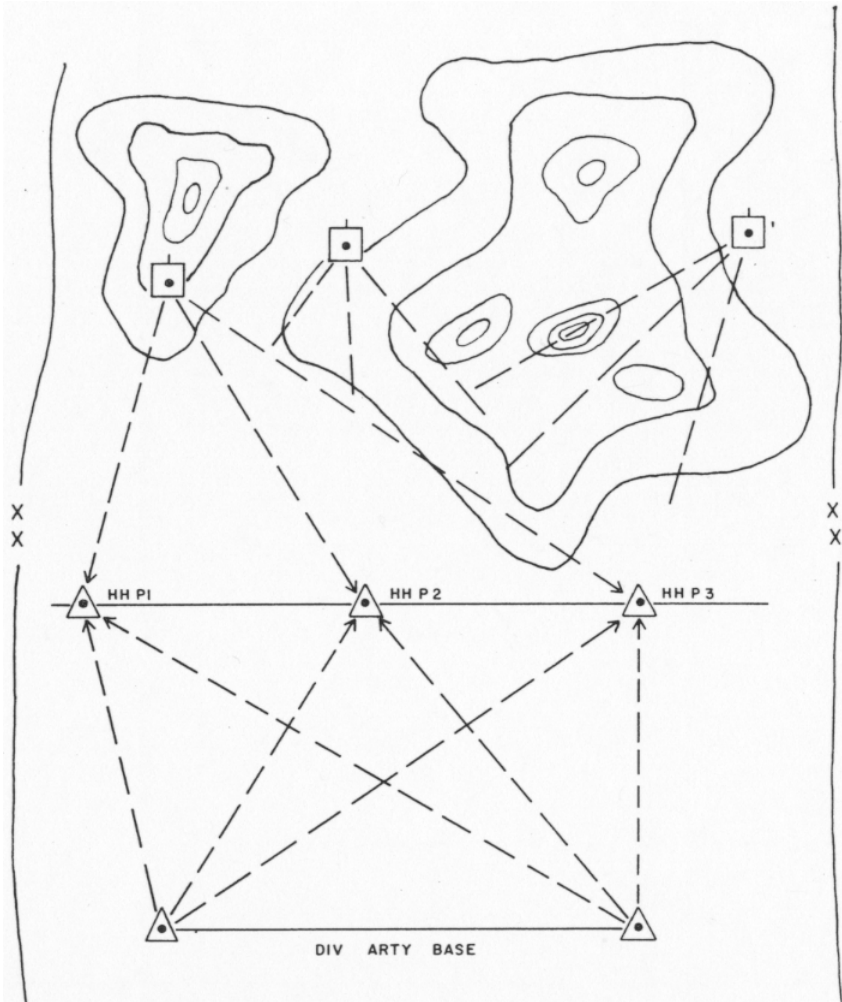

Figure 7. Surveying with the aid of LOH's.

is difficult to predict. Uncontrollable elements such as wind, refraction, personnel reaction time, a mobile target, and the fact that rotary-wing survey combines two of the less accurate methods of survey (intersection and resection), make accurate extension of survey control along the ground difficult.

Other capabilities of army aviation include transportation of commanders, aerial radiological survey (for prediction and testing of fallout levels), and aerial communication assistance to include radio relay, wire laying, message drop and pickup.

EMPLOYMENT

Planning and coordination are the key words in the employment of the aviation section. All planning and coordination is the responsibility of the division artillery aviation officer. He is a special staff officer at division artillery and is thoroughly trained in the technical and tactical aspects of aviation operations. To maximize the effect of the available aviation support, the division artillery officer is required to exercise close and continuous coordination with the division artillery S2 and S3, the artillery battalion commanders, and the division aviation battalion. He will coordinate, with the division aviation battalion, observation missions to prevent duplication of effort, maintenance requirements that cannot be performed on organic aircraft at division artillery level, and securing additional aviation support when required by division artillery.

To provide maximum aviation support, the divarty aviation section must operate from the vicinity of the division artillery fire direction center. The section will normally be employed under the operational control of the division artillery aviation officer. However, portions of the section can be attached or placed in direct support of artillery battalions.

For effective continuous observation, it may be necessary for the division artillery aviation officer to coordinate observation missions with the aerial surveillance platoon of the division aviation battalion. Working with the aerial surveillance platoon, full time observation could be accomplished without full time utilization of the artillery section aircraft. This could be done by employing fixed-wing aircraft from the aerial surveillance platoon to observe during those periods when division artillery battalions are not actively engaged. Aircraft from the artillery aviation section can be on standby for immediate missions. When targets are acquired by the aerial surveillance platoon they can be immediately relayed to aircraft of the division artillery aviation section, who can then adjust fire on the targets. At the same time the aerial surveillance platoon aircraft can be observing for other targets. Employment of this nature would accomplish a reduction in flying time on the limited number of helicopters in the aviation section, thus reducing critical maintenance requirements. This will provide more aircraft support during periods of heavy activity when it is critically needed. Aircraft from the aerial surveillance platoon will be conducting combat surveillance for the division and observation for division artillery simultaneously, thus getting full utilization of the aircraft from this platoon. Such usage will provide division artillery with a deeper target acquisition means. Aircraft in the aerial surveillance platoon are equipped with electronic acquisition means and also have all-weather capability. Normally, this platoon would not be used to adjust artillery fire, but if the target should be beyond the range of the observation helicopter from the aviation section, aerial surveillance platoon personnel can effectively adjust fire.

If observation is not coordinated with the aerial surveillance platoon it will be necessary to schedule observation helicopters in limited numbers only. This may curtail observation capabilities somewhat but may be



Figure 8. Aeromedical evacuation.

necessary in order to insure adequate aviation support over an extended period of time. This is the result of the limited number of aircraft available. The number of aircraft required to perform observation effectively will vary with the situation. More aircraft will be required in an offensive situation than in a relatively stable defense.

Adequate aviation support must be provided to the artillery commander to assist him in accomplishing his mission. In those situations in which the aviation section cannot provide the required aviation support, positive effort must be made by the division artillery aviation officer to obtain additional support from the aviation battalion. This can be done by requesting the additional support through the Army Aviation Element (AAE) at Division Tactical Operations Center or through command channels.

If the aviation section is to provide effective support during combat operations, it must be maintained at full strength. Combat losses of aircraft and aviators normally will be replaced from the division aviation battalion. However, to insure this replacement, it is recommended that this system be incorporated in the division operations order or division SOP. Replacement of trained observer losses is a responsibility of the division artillery commander; therefore, it is recommended that each division artillery operate an observer training program in accordance with AR 95-51. This can be a part of unit training of the aviation section.

The airfield should be located close to the FDC for maximum utilization and control of unit air operations. Under combat conditions, an attempt should be made to locate the airfield within the defensive perimeter of the division artillery headquarters and headquarters battery.



Figure 9. One of the entries in the Army's LOH competition.

The site must be chosen so that the approach of the aircraft, as well as the site itself, will be hidden from enemy surveillance as much as possible, and so located that it can easily be protected from encirclement or from infiltration by the enemy. Dusty sites should be avoided because dust will reveal the operation of the aircraft and create a hazard to safe operations. Natural cover for concealment of dispersed parking areas, maintenance areas, etc., is desirable, and the airfield should be located in an area which is defiladed from enemy fire and ground observation. The area required for an airfield or landing site is affected by the mean temperature and altitude of the site, since these factors have a direct effect upon the length of required ground takeoff run or the ability of the helicopter to clear obstacles. In general, a site should be selected at the lowest altitude consistent with other requirements.

In many instances it may be advantageous to consider the selection of airfield and command post sites as a joint task and, if possible, to select an area which is mutually satisfactory.

TRAINING

For effective training, an aviation unit needs to have all of its organic equipment available. If the equipment is not available or is inadequate, every effort to obtain it must be made through proper supply channels.

Because of the inherent complexity of aircraft, particularly rotary-wing aircraft, lack of critical parts and/or maintenance equipment cannot be overcome by mere field expedients. Most of the personnel assigned to this section are specialists and have probably received service school training in aviation maintenance. On-the-job training however, should be utilized to increase the efficiency of the individual and the section. Unit training of this section should be integrated into all phases of division artillery training in an effort to develop adequate knowledge of its capabilities among all artillery personnel. This can be accomplished by assigning this section, or elements thereof, to support division artillery units undergoing field exercises in such missions as: reconnaissance for position areas, convoy control to and from position areas, camouflage inspection, and adjustment of fire from an air OP. Aerial fire adjustment should be performed each time firing practice is conducted, and battery officers should perform these missions as much as possible. It may be feasible to include these missions as part of an aerial observer program.

The new organization is marked by the new organic structure of artillery aviation support. Whereas the old organization afforded artillery aviation support indirectly from the artillery support section of the aviation company, division artillery now has its own aviation section. Another improvement is an increase of two aircraft. The old artillery aviation support consisted of eight L-19 fixed-wing aircraft and two H-13 helicopters, whereas in the new organization ten light observation helicopters and two L-20 fixed-wing observation planes are now provided.

With the growing responsibilities of artillery in the support on the battlefield comes a continuing need for faster, deeper, more accurate observation, surveillance, intelligence, and reconnaissance. Artillery aviation is one of the answers to this growing need, and the new organization of aviation within the artillery strives to keep pace with the racing pulsebeat of artillery growth.

●

A class (T1750 — "Organization and Employment of Army Aviation") on the subject covered in the article above is available from the address on page 3.

●

X-RAY EXPOSURE

When working on equipment using high-voltage tubes, electronic technicians should take precautionary measures to avoid overexposure to x-rays. Some sources of x-radiation are high-voltage klystrons, high-voltage thyratrons, and magnetrons. Most of this radiation occurs near the output of these tubes and it follows the inverse square law, i.e., the intensity of the x-radiation decreases as the square of the distance from the source increases. Among known effects of overexposure to x-rays are skin cancer, mutations, ulcers, sterility, and cataracts.

AIRBORNE

DIVARTY REORGANIZATION

The United States Army Artillery and Missile School has submitted draft tables of organization and equipment for the airborne division artillery.

The reorganization of the airborne division follows the general concept of "flexibility through tailoring," as outlined in the introduction of the supplement to ARTILLERY TRENDS, August 1961.

An airborne division may consist of as many as eight parachute infantry battalions and one assault gun battalion. To provide this organization with direct and general artillery support, the division artillery must have the capability to:

- afford conventional and nuclear support to include the division artillery component of the communication, target acquisition, liaison, and survey systems.
- establish the fire support element of the division fire support coordination center.
- land by parachute and aircraft.
- be cross-country mobile and to emplace rapidly when required for a long duration operation.
- command and control additional artillery units attached to the airborne division.

The airborne division is, of course, 100 percent air mobile.

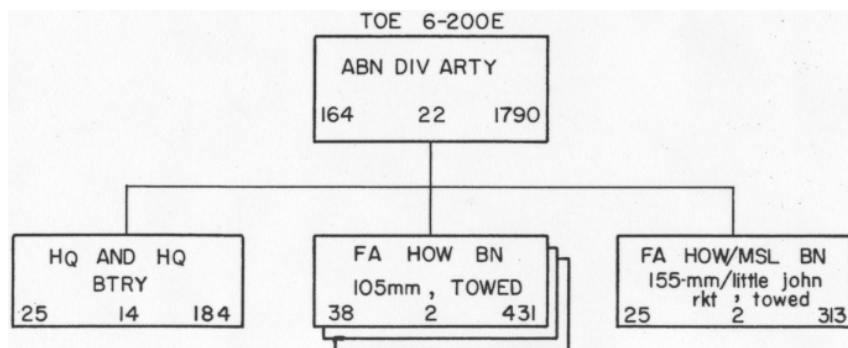
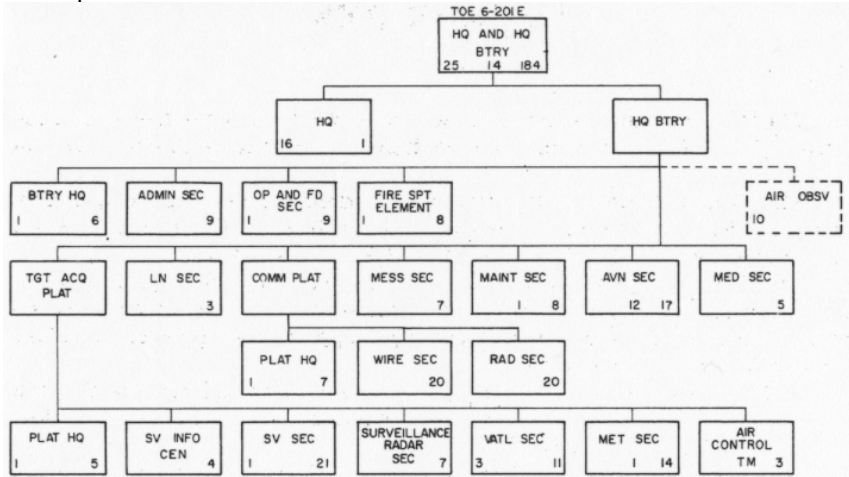

Figure 10. The airborne division artillery.

HEADQUARTERS AND HEADQUARTERS BATTERY

In directing and coordinating the operations of the division artillery and attached units, the headquarters and headquarters battery (fig 11) must be prepared to provide staff planning, supervision, coordination, and control and must be parachute-capable, too. All of its personnel and equipment, except for the shop van trucks and gasoline tank 2 1/2-ton truck is airportable in C-119 or C-123 planes.



Shoot

.45 cal pistol—45
7.62-mm rifle—184
7.62-mm machine gun—11
3.5-in rocket launcher—9
40-mm grenade launcher—4

Move

Airplanes:
Utility—2
Helicopter, obsn—10

Trucks:
1/4-ton—16
3/4-ton—24
(plus 7 w/winch)
2 1/2-ton—5
(plus 2 w/winch)

Ambulance:
3/4-ton—1

Shop van:
2 1/2-ton—2

Tank, gasoline:
2 1/2-ton—1

Trailers:

1/4-ton—4
3/4-ton—29
1 1/2-ton—7
water—2

Communicate

Radios:

AN/GRC-19—3
AN/GRR-5—5
AN/ARC-9—6
AN/ARC-10—1
AN/URC-4—12
AN/VRC-9—17
AN/VRC-10—3
AN/VRQ-2—2
AN/VRC-24—2
AN/GRC-46—9

Switchboards:

SB-22/PT—3
SB-86/P—2

Telephones:

TA-264/PT—3
TA-312/PT—49

Antennas:

AN/GRA-4—1
RC-292—9

Locate

Surveying instrument,
azimuth-gyro—2
Survey set, 3d order—2
Survey set, 4th order—1
Tellurometer master—2
Tellurometer remote—4
Theodolite (0.002 mil)—6
Radar set AN/TPS-25—1
Binoculars:
6 × 30—15
7 × 50—9
Circle, aiming—1
Visual survey system
AN/UVS-1—1

Figure 11. Headquarters and headquarters battery with some of its major equipment.

THE 105-MM HOWITZER BATTALION, TOWED

The direct support battalion of the airborne division is the towed 105-mm battalion (fig 12). Although primarily a direct support unit, this battalion must also be prepared to provide general and/or reinforcing support to the airborne division in certain instances.

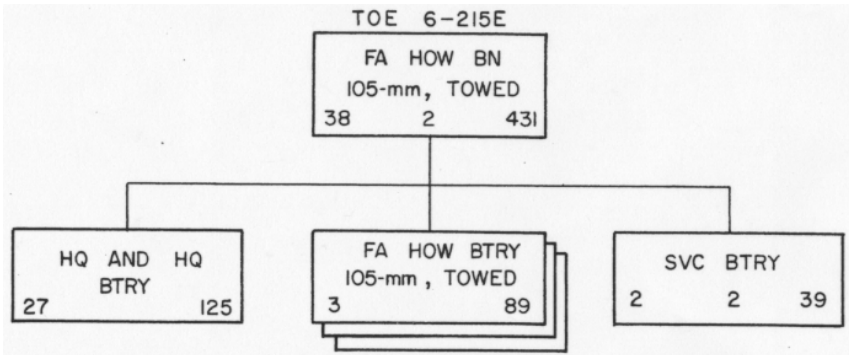
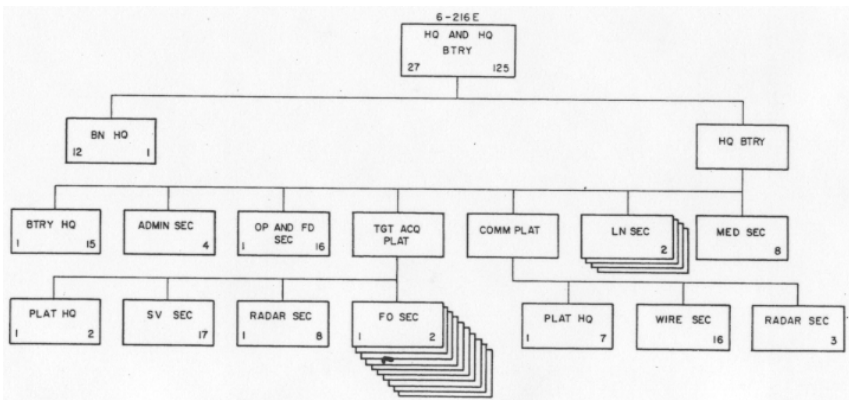

Figure 12. FA howitzer battalion, 105-mm, towed.

HEADQUARTERS AND HEADQUARTERS BATTERY

The headquarters and headquarters battery (fig 13), organic to the airborne division 105-mm battalion, has the duties of staff planning, supervision, coordination, and control of operations of organic and attached units of the battalion. It provides the observation and survey systems for the battalion.



<i>Shoot</i>	<i>Communicate</i>	<i>Locate</i>
.45 cal pistol—18	Radios:	Surveying instrument,
7.62-mm rifle—134	AN/GRR-5—2	azimuth-gyro—1
7.62-mm machine gun—5	AN/PRC-9—15	Survey set, 3d order—2
3.5-in rocket launcher—4	AN/PRC-10—10	Survey set, 4th order—1
40-mm grenade launcher—4	AN/VRC-9—25	Theodolite (0.2 mil)—2
<i>Move</i>	AN/VRC-10—1	Radar set AN/MPQ-4—1
Trucks:	AN/VRQ-2—5	Binoculars:
1/4-ton—19	AN/GRC-46—1	6 × 30—30
3/4-ton—18	Switchboards:	7 × 50—10
2 1/2-ton—3	SB-993/GT—4	Circle, Aiming—3
Ambulance:	SB-22/PT—8	
3/4-ton—1	Telephones:	
Shop van:	TA-264/PT—1	
2 1/2-ton—1	TA-312/PT—70	
Trailers:	Antennas:	
1/4-ton—15	RC-292—8	
3/4-ton—11		
1 1/2-ton—1		
water—1		

Figure 13. Organization chart and major equipment of headquarters and headquarters battery, 105-mm battalion, towed.

105-MM HOWITZER BATTERY, TOWED

The 105-mm howitzer battery, towed, of the 105-mm battalion (fig 14), is augmented by 75-mm pack howitzers as discretionary equipment in the event the airborne division is given a mission requiring lightweight materiel. There are three batteries in each 105-mm howitzer battalion.

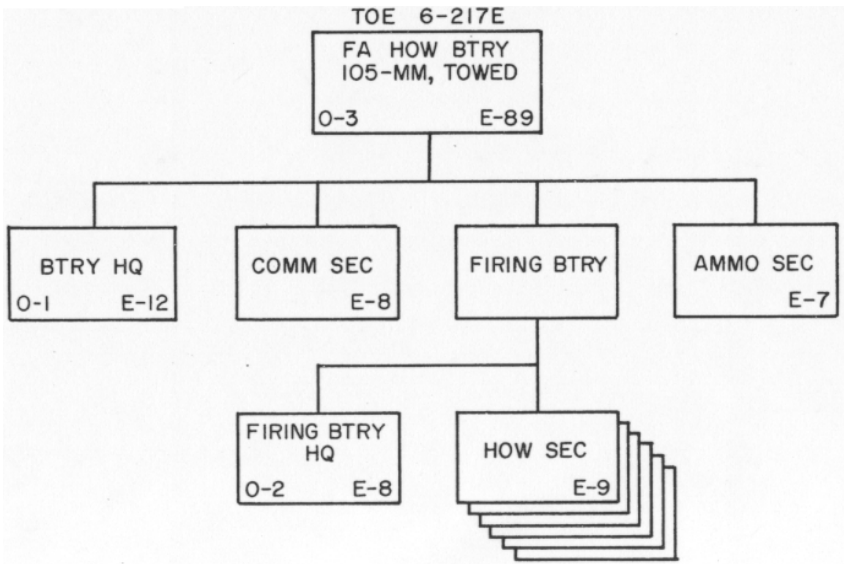

<i>Shoot</i>	<i>Trailers:</i>	<i>Switchboards:</i>
105-mm howitzer—6	1/4-ton—2	SB-22/PT—1
75-mm howitzer—6	3/4-ton—3	<i>Telephones:</i>
(WABTOC)	1 1/2-ton—1	TA-312/PT—19
.45 cal pistol—7	water—1	<i>Antennas:</i>
7.62-mm rifle—85	ammo—3	RC-292—2
7.62-mm machine gun—8	<i>Communicate</i>	<i>Locate</i>
3.5-in rocket launcher—5	<i>Radios:</i>	Circle, aiming—2
40-mm grenade launcher—6	AN/GRR-5—1	<i>Binoculars:</i>
<i>Move</i>	AN/VRC-9—3	6 × 30—3
<i>Trucks:</i>	AN/VRC-17—1	
1/4-ton—2		
3/4-ton—9		
2 1/2-ton—11		

Figure 14. The 105-mm howitzer battery, towed; its organization and major equipment.

SERVICE BATTERY, 105-MM HOWITZER BATTALION

The mission of the service battery (fig 15) is to procure, break down, and distribute all classes of supplies to units of its battalion and to maintain appropriate supply records and perform motor maintenance functions not otherwise accomplished within the battalion.

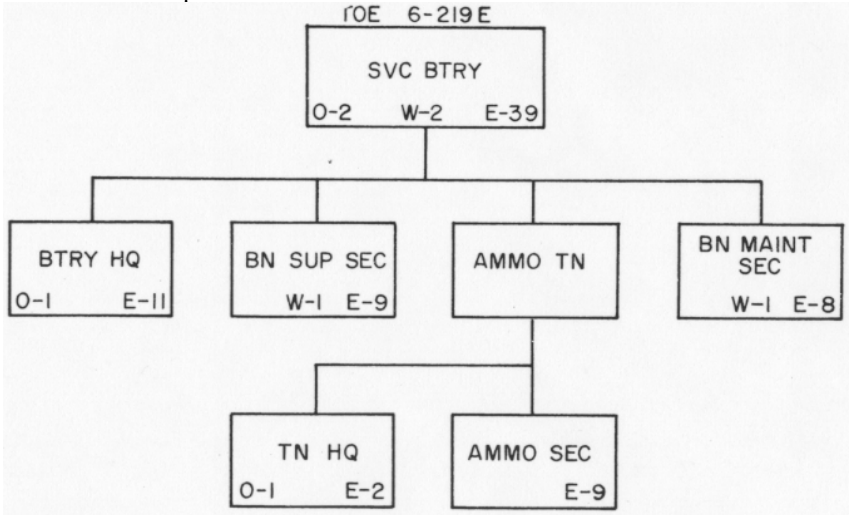

<i>Shoot</i>	<i>Move</i>	<i>Trailers:</i>
.45 cal pistol—4	<i>Trucks:</i>	1/4-ton—3
7.62-mm rifle—39	1/4-ton—3	3/4-ton—1
7.62-mm machine gun—8	3/4-ton—1	1 1/2-ton—1
3.5-in rocket launcher—7	2 1/2-ton—8	water—1
40-mm grenade launcher—3	wrecker, 2 1/2-ton—1	ammo—4

<i>Communicate</i>	Telephones:
Radios:	TA-312/PT—10
AN/GRR-5—1	Antennas:
AN/VRC-9—4	RC-292—1
Switchboards:	
SB-22/PT—1	

Figure 15. Organization and equipment, service battery, 105-mm howitzer battery, direct support battalion.

HOWITZER/MISSILE BATTALION

The howitzer/missile battalion (155-mm/Little John) (fig 16) is organized to provide general and/or reinforcing artillery support to the airborne division.

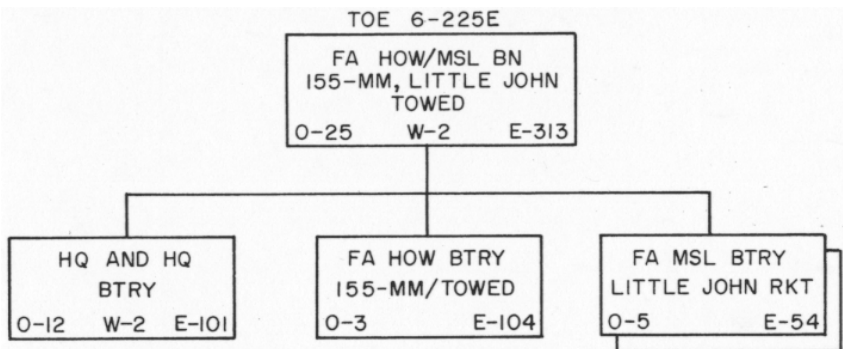

Figure 16. The FA howitzer/missile battalion, airborne division.

This battalion provides indirect neutralization, interdiction, and destruction fires. It furnishes its portion of communication, fire direction, and survey. Six 105-mm howitzers are included as discretionary equipment in the event a mission requiring lightweight weapons is given to this unit.

HEADQUARTERS AND HEADQUARTERS BATTERY, HOWITZER/MISSILE BATTALION

<i>Shoot</i>	1/4-ton—11	Trailers:
.45 cal pistol—12	3/4-ton—20	1/4-ton—8
7.62-mm rifle—103	2 1/2-ton—6	3/4-ton—16
7.62-mm machine gun—8	wrecker, 2 1/2-ton—1	1 1/2-ton—4
3.5-in rocket launcher—4	Ambulance:	water—1
40-mm grenade launcher—4	3/4-ton—1	
<i>Move</i>		
Trucks:		

Communicate

Radios:

- AN/GRR-5—2
- AN/PRC-9—6
- AN/VRC-9—15
- AN/VRQ-2—1
- AN/GRC-46—3
- AN/GSA-7—2

Switchboards:

- SB-22/PT—4

Telephones:

TA-264/PT—2

TA-312/PT—31

Antennas:

RC-292—3

Locate

Surveying instrument,
azimuth-gyro—1

Survey set 3d order—3

Theodolite (0.2 mil)—3

Binoculars:

6 × 30—10

Circle, aiming—3

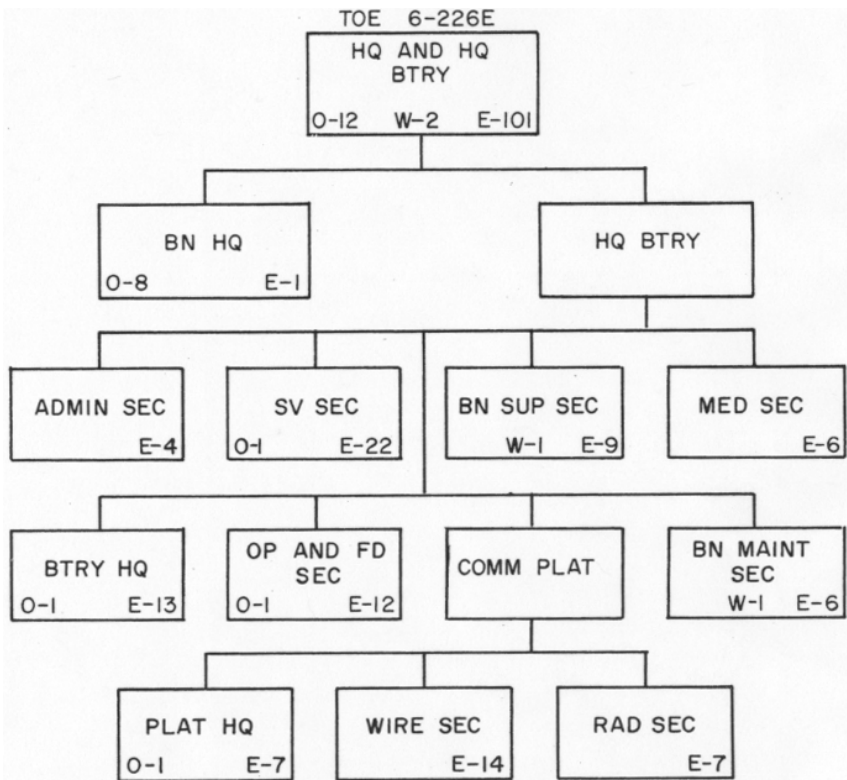
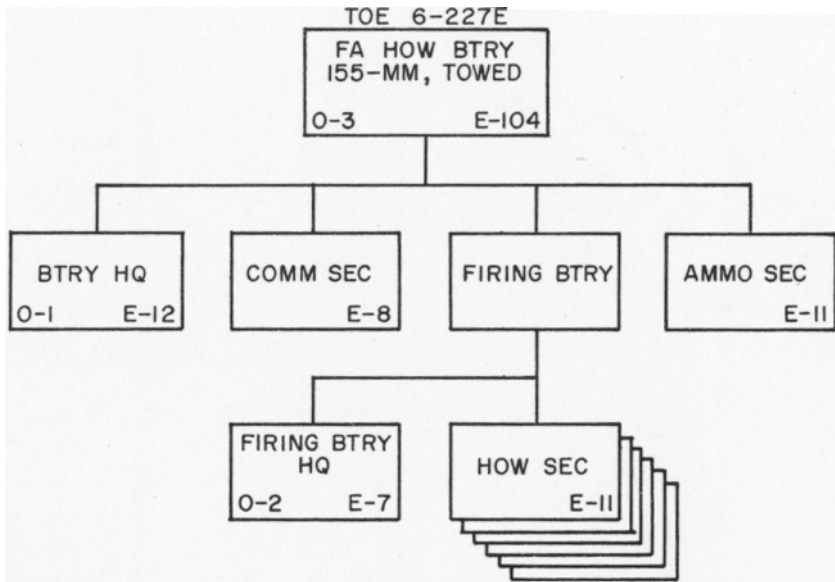

Figure 17. Organization and equipment, headquarters and headquarters battery, howitzer/missile battalion.

155-MM HOWITZER BATTERY, TOWED

In the airborne division, the 155-mm howitzer battery (fig 18) is used for general support, along with the Little John rocket. Whereas the Little John can provide the nuclear punch necessary, the 155-mm howitzer offers high explosive support in quantity and inexpensively.



Shoot

- 155-mm howitzer—6
- 105-mm howitzer—6
(WABTOC)
- .45 cal pistol—9
- 7.62-mm rifle—98
- 7.62-mm machine gun—9
- 3.5-in rocket launcher—9
- 40-mm grenade launcher—8

Move

- Trucks:
- 1/4-ton—2
 - 3/4-ton—3
 - 2 1/2-ton—13
 - 5-ton—6

Trailers:

- 1/4-ton—2
- 3/4-ton—3
- 1 1/2-ton—1
- water—1
- ammo—5

Communicate

- Radios:
- AN/GRR-5—1
 - AN/VRC-9—3
 - AN/VRC-17—1

Switchboards:

- SB-22/PT—1

Telephones:

- TA-312/PT—16

Antennas:

- RC-292—2

Locate

Binoculars:

- 6 × 30—2

- Circle, aiming—2

Figure 18. 155-mm howitzer battery, towed.

LITTLE JOHN ROCKET BATTERY

Shoot

- 318-mm rocket launcher
XM34—2
- .45 cal pistol—7
- 7.62-mm rifle—52
- 7.62-mm machine gun—8
- 3.5-in rocket launcher—7
- 40-mm grenade launcher—6

Move

- Trucks:
- 1/4-ton—9
 - 3/4-ton—7
 - 2 1/2-ton—2
- Trailers:
- 1/4-ton—2
 - 3/4-ton—2

1 1/2-ton—1
 water—1
Communicate
 Radios:
 AN/GRR-5—2
 AN/VRC-9—5
 AN/VRC-17—1
 Switchboards:
 SB-22/PT—1

Telephones:
 TA-312/PT—20
 Antennas:
 RC-292—2
Locate
 Binoculars:
 6 × 30—3
 Circle, aiming—4

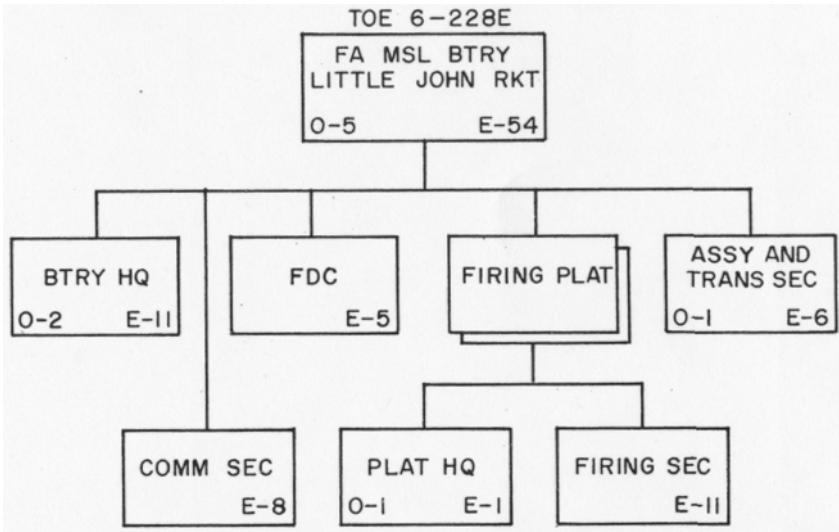

Figure 19. Organization and equipment, Little John Rocket battery, howitzer/missile battalion.

More information on the airborne reorganization is available in class T 7063 ("Organization of the Infantry, Armor, Mechanized, and Airborne Divisions"). To obtain it, consult page 3.

A GEM FOR THE SURVEY SECTION

When establishing a long base for intersection or triangulation type survey, it is sometimes difficult to see the range pole used to mark the station at each end of the base. If a rodman is left at each station with a 4" by 4" piece of polished sheet metal (or a steel mirror, such as field troops use for shaving), he can signal at short time intervals by reflecting the sun. This gives the instrument operator the exact location of the range pole, thus insuring the turning of the proper angles.

—submitted by SFC Joseph Giorno, Jr.

Hq Btry
 2nd How Bn, 126th Arty
 32d Infantry Division
 Wisconsin National Guard

Long-range considerations . . .

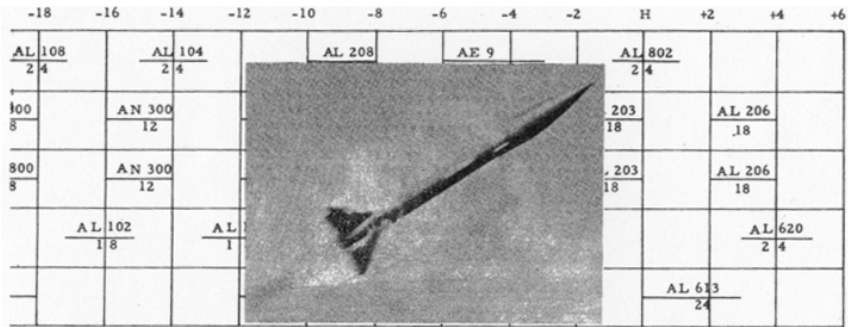

MISSILE FIRE PLANNING

Captain James B. Agnew

Tactics/Combined Arms Department

Sir William Congreve, eminent British rocket proponent of yesteryear, stated, "The rocket is, in truth, an arm by which the whole system of military tactics is destined to be changed." When one considers the necessary dispersion of the nuclear battlefield and the initial nuclear fire fight demanding relative immobility of the ground-gaining arms, it becomes immediately apparent that Congreve's statement is still valid today. If we take the liberty of substituting "missile" for "rocket" in his quotation, it becomes meaningful to an understanding of current artillery organization. A glance at a type field army troop list confirms the presence of considerable missile and rocket artillery. The tactical implications of these weapons have become increasingly more significant.

The changes brought about by the arrival of the missile on the artillery tactical stage are legion. As a point of departure, let us confine ourselves to consideration of only one aspect of tactics—artillery fire planning.

Fire planning is regarded as the keystone of fire support. The combination of maneuver and firepower is effected in this systematic approach to achieve an overwhelming preponderance of combat might on the battlefield. The fire plan bears witness to the artilleryman's ability to accomplish the mission. Now, his professional ability is challenged anew. Integration of missile fires into the plan of fire support requires careful appraisal of long-tested techniques and a review of several principles.

MISSILE CONSIDERATIONS

What are the operational considerations which necessitate modifications to current fire planning principles? Several inherent characteristics

of the various systems presently within the field must be continuously appraised by fire planners for most effective employment. Some of the characteristics to be considered are:

Accuracy

Design CEP's and achieved CEP's must become familiar factors in target evaluation and selection of weapons. The fire planner must be sure that the size and nature of the target are within the fall-of-shot capability of the particular system(s) under consideration. We cannot expect 8-inch howitzer accuracy with an Honest John; therefore, the Honest John should not be planned against point targets, the area of which is so small that a direct hit becomes improbable. A factor in this consideration is the remunerativeness of the target. Certainly, a suspect platoon CP is not an economically logical target for a missile, particularly if it falls within the range of conventional howitzers.

Reliability

If the destruction of a target is imperative, the fire planner must consider the reliability achieved by the various operational missile systems. Reliability requirements specify that missile units are required to deliver effective fire within a prescribed timespan. If experience reveals that a system has attained this "time-on-target" with the prescribed accuracy, this may be an overriding consideration in scheduling, even though other systems may appear to have greater accuracy, faster reaction times, etc.

Range

Weapon range has long been of primary interest in positioning batteries and assigning targets. Generally, missile ranges exceed those of cannon. Advantage may be taken of these ranges to hit lucrative targets relatively deep within the enemy zone of action. A good rule of thumb for the fire planner would be to schedule maximum close-in fires for cannon, reserving the deeper target for missile batteries. It is apparent that we waste firepower when assigning close-in targets for missiles, if cannon are able to accomplish the damage desired.

Signatures

Even though the rate of fire for a missile system is usually given in available publications, it is not necessarily true that the system can exploit this capability. Upon departure from the firing platform, rockets and missiles emit certain exhaust gases commonly known as *backblast*. This backblast normally creates a cloud of dust and debris in the vicinity of the launcher. During flight, the trajectory of the missile is described by a trail of smoke. It goes without saying that these "signatures" invite counterbattery fire on the missile position area. Displacement may be desirable and, while en route, the firing capability of the unit may be considerably reduced, in some cases entirely negated. Obviously, the fire planner should not assign missions during the period of displacement and occupation of a subsequent position.

Equipment Peculiarities

Fires of certain missile systems may be restricted by the capabilities of equipment peculiar to the system. For example, consider the Lacrosse

battalion. To insure most accurate fire, the Lacrosse forward guidance central should be emplaced on terrain permitting observation of the entire target area. If specific targets requiring extreme accuracy are masked from observation, one should not schedule them for Lacrosse. It should not be assumed that Lacrosse *cannot* deliver effective fire on deeper targets, because it *does* indeed possess the range capability. System design, however, indicates greatest reliability can be expected when the missile is fired with the target in view of the guidance equipment. Other systems have their own equipment limitations, all of which must be considered in fire planning.

Technical Gunnery

Until the universal adoption of electronic computing devices throughout the artillery, solution of the missile gunnery problem continues as a time-consuming and tedious paper process. Although innovations through experience continue to reduce the time and personnel necessary to compute firing data, no missile system gunnery achieves the rapidity of cannons' graphic solutions. Extreme discretion must be exercised when assigning targets of opportunity to missile units. Should these targets be transient by nature, the fire planner adds the risk that targets will have displaced before the missile gunnery problem is solved by a fire unit. In many instances, range capability and the tactical situation will determine whether this risk is acceptable. For general guidance, preplanned targets are more compatible than targets of opportunity for missile destruction.

Destructive Power

Missile warheads bridge the gap between the comparatively small destructive force of explosive projectiles and the more lethal aerial bombs. Hence, the artillery commander may accomplish the desired effects more rapidly by firing one missile than by employing several cannon battalions. Conversely, overkilling with destructive warheads is extravagant and is not in line with the finesse accredited to the skillful artilleryman.

Logistics

Cannon battalion ammunition officers have for decades prepared a transportation order and dispatched trucks to ordnance ammunition supply points. These vehicles, normally one per firing battery, have returned with the battalion's entire basic load for a day. The rounds were dropped at each gun position and, with little further effort, were immediately available for firing. Missile resupply is more complex. Special-purpose vehicles, squads of technicians, and security forces are now required to draw, transport, and prepare the basic load. Hours are consumed in inspection, unpackaging, and checkout of numerous subassemblies before the complete round is delivered to the fire unit. The fire planner must determine if the selected missile battalion has on hand enough missiles to accomplish a specific mission and whether the expenditure of missiles at a given time will reduce the unit's operational capability for contemplated future action before resupply can be completed. The hypothetical prescribed loads or number of rounds available to any given missile unit do not appear to be restrictive in this sense. The problems arise from

the technical nature of assembly and preparation. Here, each step is necessarily precise and deliberate, entailing delay from receipt to delivery heretofore not experienced in cannon units. BATTERY 3 ROUNDS will probably never be heard in a guided missile firing battery.

These considerations merit attention for their significance as departures from proven tactical fire planning principles. Despite the apparent exotic nature of missile systems, there is no evidence to indicate that radical and far-reaching revisions in fire planning procedures are implied. Any changes should be additive, not adulterative. Artillery commanders and their staffs must be cognizant of the missile's presence in order that its fires may be integrated effectively into the plan of fire support. A general understanding of each system and familiarity with the capabilities and limitations of each, combined with previous experience and sound judgment, will enable the artilleryman to employ missile firepower in its proper perspective.

●

COLD WEATHER INJURY

Various types of cold weather injuries have long been a military problem. Trench foot, immersion foot, and frostbite are the cold injuries of greatest military importance. Trench foot results from prolonged exposure to cold at temperatures from just above freezing to 50° Fahrenheit (F.), with accompanying wetness of the feet. The term immersion foot implies a cold injury of the feet resulting from prolonged exposure, usually in excess of 12 hours, in water at temperatures usually below 50° F. Frostbite, the cold injury of greatest significance to artillerymen, refers to the crystalization of tissue fluids in the skin or subskin tissues and is produced by exposure at temperatures of freezing or below. Low temperatures and low relative humidity favor frostbite.

A very important factor which must be considered simultaneously with temperature is wind velocity. The combination of wind velocity and temperature, or wind chill, accelerates body heat loss under conditions of both cold and wet. As wind chill is one of the major factors in the production of cold injuries, a wind chill chart (fig 44) has been compiled to furnish guidance for planning purposes. The figures in the table are to be used as approximate equivalents only and not to be interpreted as absolute temperature equivalents. The term "wind chill" as used here expresses the *rate of cooling* which occurs in the *exposed or inadequately protected flesh*. Equivalent wind chill figures of +23° F., 0° F., or —40° F., even though they are below the freezing point of water (+32°F.), do not mean that all exposed flesh will freeze solid nor that even the surface will be frozen. Regardless of the wind speed, actual temperature readings above 32° F. will never result in freezing of exposed flesh. On the other hand all unprotected flesh exposed to temperatures below +20° F., regardless of wind speed, may freeze.

Wind Chill Chart page 63

From group to battalion . . .

REDSTONE REORGANIZED

Captain George M. Rodgers
Tactics/Combined Arms Department

With the reorganization of the US Army comes a new organization for Redstone. The most obvious and significant change is that from a group to a battalion. The battalion will be assigned to a field army on a basis of one battalion per army. The overall mission of Redstone remains the same: to provide field artillery missile nuclear fire in general support of the field army. More specifically, it will be the Redstone battalion's job to deliver nuclear fire on targets beyond the range of other field artillery units, to accomplish mass destruction on large area targets, to afford continuous fire support by displacing its two missile batteries by echelon, and finally, to provide organizational supply and maintenance for the complete missile system. Figure 26 reflects the changes in personnel authorizations incident to the change in the Redstone organization.

THE REDSTONE BATTALION

The Redstone battalion (fig 20) is composed of a headquarters and headquarters battery, two field artillery missile batteries, an engineer company, and an ordnance company. The battalion is organized under the battalion fire unit principle, which simply means that the battalion, rather than the battery, is the fire unit. Like other artillery battalions, the Redstone battalion is also the tactical and administrative organization.

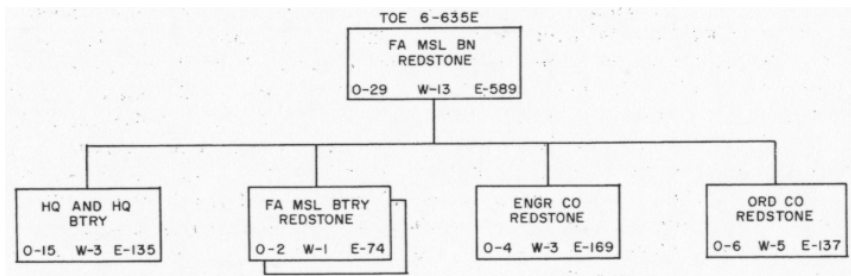

Figure 20. Field artillery missile battalion, Redstone.

The Redstone battalion staff (fig 21) consists of 14 officers and 1 enlisted man. For the most part, the duties of these staff members are comparable to the traditional duties of their counterparts in cannon artillery units. The assignment of an engineer company and an ordnance

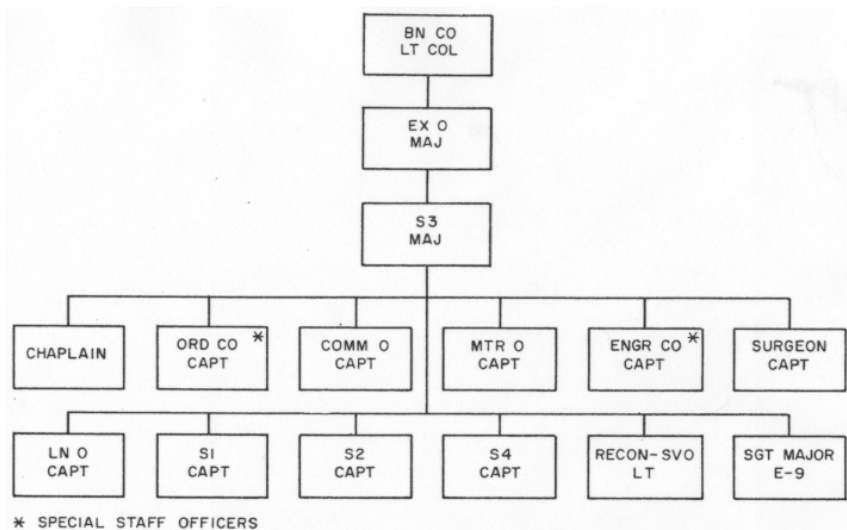

Figure 21. Redstone battalion staff.

company to the battalion places certain additional responsibilities on the battalion commander. For example, he must be familiar with the capabilities and limitations of all units within the battalion (engineer and ordnance as well as artillery) so that he can properly advise the next higher commander on employment of the battalion. He may even be required to assist the next higher commander in the selection of targets for his battalion. In addition the S3, on receipt of a fire mission, must coordinate the activities not only of the firing batteries but also of the engineer and ordnance companies.

HEADQUARTERS AND HEADQUARTERS BATTERY

The headquarters and headquarters battery (fig 22) contains the necessary administrative and service elements to support the battalion and, when augmented by the security detachment, provides security personnel for safeguarding nuclear warheads.

The *battery headquarters* consists of the personnel and equipment necessary for the administrative and tactical control of the headquarters battery.

The *operations and intelligence platoon* contains a platoon headquarters, an administrative section, and a survey section. The *platoon headquarters* consists of the necessary personnel and equipment to perform the functions of fire direction and liaison. The platoon headquarters can support two fire direction centers, thus allowing fire direction operations to be performed at each firing battery if necessary. The platoon headquarters has a liaison sergeant and the necessary liaison communications

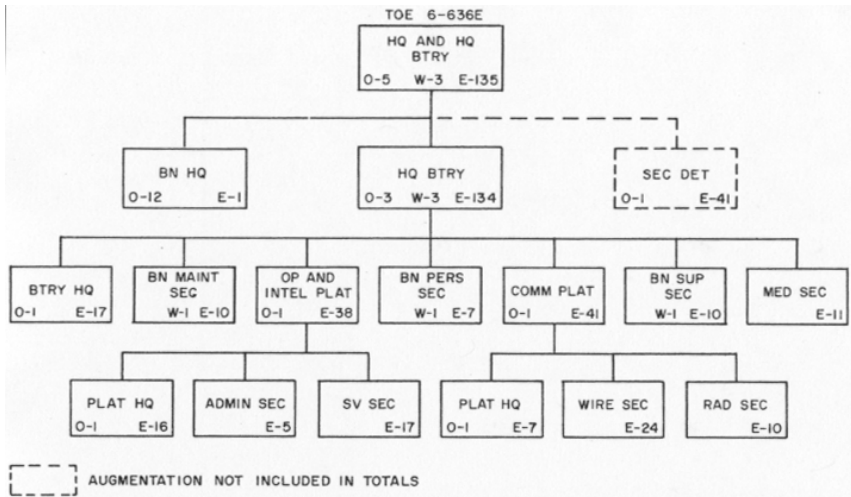

Figure 22. Headquarters and headquarters battery.

to assist the battalion liaison officer. The *administrative section* consists of the personnel and equipment to support the battalion commander and staff in administrative matters. The *survey section* is composed of two field artillery survey teams which furnish the firing batteries with the required survey control. Survey control should be furnished to within approximately 1,000 meters of each firing position by an engineer topographic battalion or a field artillery target acquisition battalion.

The *battalion communication platoon* is equipped to provide communications to the subordinate units and to higher headquarters when necessary. Each subordinate unit establishes its own internal communication system.

The functions of the *battalion personnel, maintenance, and medical sections* are comparable to those of cannon battalion personnel, maintenance, and medical sections.

The *battalion supply section* consists of the personnel and equipment to handle the supply functions normally performed by a cannon battalion supply section.

MISSILE FIRING BATTERIES

There are two missile batteries organic to the battalion. Each battery (fig 23) is composed of a battery headquarters, a communication section, and a firing battery.

The *battery headquarters* contains the necessary equipment and administrative, supply, maintenance, and mess personnel to perform battery administrative, supply, maintenance, and mess functions.

The *communication section* consists of the personnel and equipment to operate and maintain the battery communication system.

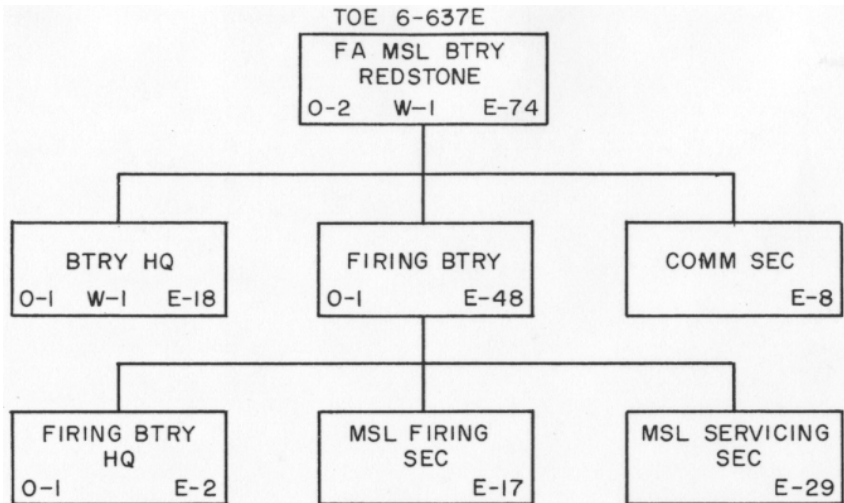

Figure 23. Field artillery missile battery, Redstone.

The *firing battery* has a headquarters for control, a missile firing section, and a missile servicing section. The *firing section* consists of the necessary personnel to operate the air compressor truck, air servicer, missile test and fire control equipment, and auxiliary equipment. The firing section, in general, performs all operations pertaining to electrical cabling, pneumatic line installation, missile testing, and missile pressurization. The *missile servicing section* consists of the necessary personnel to maintain the launcher, lightweight erection equipment, missile and propellant transport vehicles, and firefighting equipment. The servicing section, in general, performs all operations pertaining to missile and fuel transport; missile assembly, other than intercabling; missile erection; and missile fueling. Each missile battery has one launcher, giving the battalion a two-launcher firing capability.

THE ENGINEER COMPANY

The engineer company, Redstone (fig 24), is composed of a company headquarters, a maintenance platoon, and two liquid oxygen generating platoons. Furthermore, the engineer company will be augmented, when authorized, with a liquid nitrogen (LN₂) supply section or a carbon dioxide (CO₂) generating section.

The *company headquarters* is the command and administrative element of the company. It provides mess, supply, and administrative facilities for the personnel of the unit.

The *maintenance platoon* is responsible for the field maintenance of mechanical engineer items in the battalion. It provides engineer maintenance contact teams for repair at the firing position; the teams are on a standby basis during fire missions. The platoon also performs second-echelon

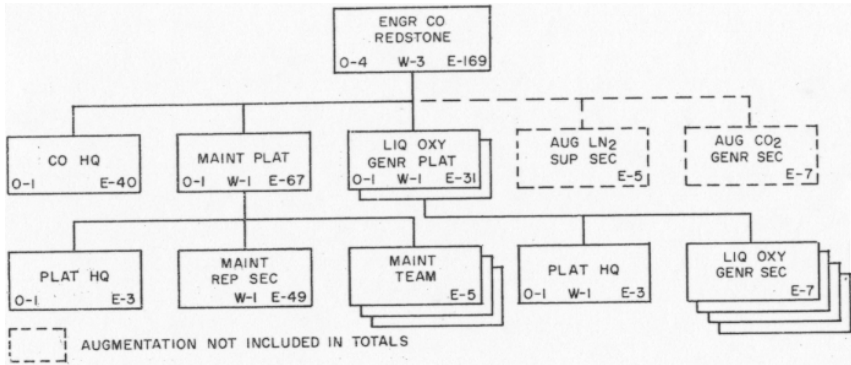

Figure 24. Engineer company, Redstone.

maintenance on its organic ordnance and engineer equipment.

The *liquid oxygen generating platoons* generate, store, and transport liquid oxygen. In addition, these platoons perform preventive maintenance on all their operating equipment and produce liquid nitrogen as required.

The *augmentation liquid nitrogen (LN₂) supply section* is equipped with four skid-mounted oxygen storage (3/4-ton) tanks, each carried in a 1 1/2-ton trailer and pulled by a 2 1/2-ton truck, and one semitrailer-mounted 9-ton liquid oxygen storage tank pulled by a 5-ton truck tractor. These vehicles and tanks are used for the transport and storage of LN₂ required for Block II missiles.

The *augmentation carbon dioxide (CO₂) generating section* is equipped with necessary facilities to produce and store dry ice (CO₂) required for Block I missiles.

THE ORDNANCE COMPANY

The ordnance company, Redstone (fig 25), is composed of a company headquarters, an operations section, a missile maintenance platoon, a supply platoon, an automotive maintenance platoon, and a firing trainer section.

The *company headquarters* is the command and administrative element of the company. It provides mess, unit supply, and administrative facilities for the personnel of the unit except that administration required for personnel management.

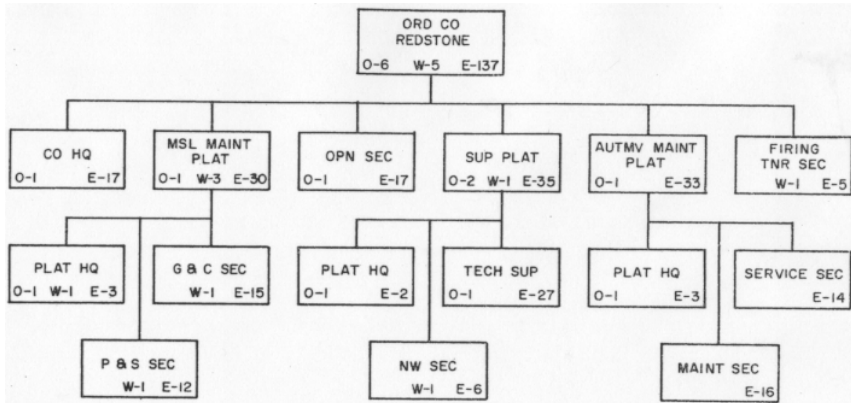

Figure 25. Ordnance company, Redstone.

The *operations section* is the focal point for all mission activities performed by the unit. The operations officer is the coordinator for all maintenance and supply activities. The master control records for maintenance and supply functions are maintained by this section, and requests for special contact teams are coordinated by the section.

The *missile maintenance platoon* provides missile system maintenance. It supplies the contact teams to work outside the physical confines of the unit shop; e.g., at the firing batteries and ordnance unit storage points. The main functions of this platoon include preissue inspections, component repair, and in-storage inspections.

The *supply platoon* performs all supply functions within the unit with the exception of unit supply. These functions include the supply of major Redstone items and missile fuel, and the supply of repair parts to the operating sections of the ordnance company and the firing batteries.

The *automotive maintenance platoon* is responsible for all supporting functions of the unit, such as machine shop facilities, welding facilities, wrecker service, and field maintenance for automotive equipment. The platoon provides special personnel and equipment to the contact teams as deemed necessary for the performance of a particular task.

The *Redstone trainer section* operates and maintains the Redstone trainer and furnishes training support to the firing batteries as directed by the battalion S3.

This is the new Redstone organization, the Field Artillery Missile Battalion, Redstone, which has the mission of providing missile nuclear fire in general support of the US field army.

The Redstone battalion, an extremely hard-hitting, reliable organization which is responsive to the requirements of the army commander, can influence the actions on the battlefield to a depth and to a degree never before possible.

REDSTONE BATTALION

ADDITIONS	DELETIONS	ADDITIONS	DELETIONS
1. To total strength—15 enlisted men.	1. From total strength—2 Officers and 1 Warrant Officer.	Headquarters Battery	Headquarters Battery
1. To total strength—6 EM.	1. Medical section.	1. Mess Section.	1. Mess Section.
2. Augmentation Security Detachment (1 Off, 41 EM).			
Battalion Headquarters		Missile Battery	
1. Battalion Commander (Lt Col).	1. Group Commander (Col).	1. To total strength—13 EM.	1. From battery headquarters—mess, maintenance, communication, and headquarters sections.
2. Battalion Executive Officer (Maj).	2. Group Executive Officer (Lt Col).	2. To battery headquarters—maintenance, and headquarters mess personnel.	
3. Battalion Communications Officer (Capt).	3. Group Communications Officer (Maj).	3. Communications section.	
4. Battalion S1 (Capt).	4. Group S1 (Maj).	4. Firing battery headquarters.	
5. Battalion S2 (Capt).	5. Group S2 (Maj).	Engineer Company	
6. Battalion S3 (Maj).	6. Group S3 (Maj).	1. To total strength—16 EM.	1. From total strength—1 Officer
7. Battalion S4 (Capt).	7. 2 Group Liaison Officers (Capt).	2. To maintenance platoon—maintenance repair section and 3 maintenance teams.	2. From maintenance platoon—general repair, automotive repair, and engineer equipment repair sections.
8. Battalion Chaplain (Capt).		3. Augmentation liquid nitrogen supply section (5 enlisted men).	
9. Battalion Surgeon (Capt).	8. Group Recon-Survey Officer (Capt).	Ordnance Company	
10. Battalion Liaison Officer (Capt).	9. 2 Group Assistant S3's (Capt).	1. To supply platoon—technical supply and nuclear weapons sections.	1. From total strength—1 Officer, 1 WO, and 33 enlisted men.
11. Battalion Motor Officer (Capt).	10. Group General Supply Officer (WO).		2. From supply section—general supply, special weapons, and missile and fuel supply sections.
12. Battalion Recon-Survey Officer (Lt).	11. Group Maintenance Officer (WO).		3. Security platoon.
13. Battalion Sergeant Major (E9).	12. Group Chaplain (Capt).		4. Signal maintenance section.
	13. Group Surgeon (Capt).		
	14. Group Sergeant Major (E9).		

Figure 26. Additions and deletions to old Redstone Group organization.

FDC speed, simplicity, sureness . . .

Stick

and

Fan Status

Lieutenant Milton S. Newberry
Gunnery/Cannon/Rocket Department

Calling all battalion commanders, battery commanders, and executive officers . . . here again, in the form of handy, removable status charts (figures 27 and 28), is the latest information concerning graphical fire direction equipment.

Newly designed graphical equipment has been developed with the advent of new tabular firing tables. Graphical equipment based on the new firing table FT 155-Q-3 for the 155-mm howitzer, published in January 1960, was the first to appear with a change in size and design (ARTILLERY TRENDS, May 1960). Two additional firing tables have been published and the associated graphical equipment has been produced. FT 8-J-3 was published in January 1961 and FT 8-0-3 was published in August 1961. FT 105-H-6 is scheduled to be published early in 1962.

Graphical equipment for use with FT 155-Q-3—including scale, graphical firing, M64 (formerly GFT); scale, graphical firing, site, M67 (formerly GST); and scale, graphical firing, M70, for use with illuminating projectile M118, MODS—has been produced and sent to ordnance depots for issuance to the user units. It is anticipated that at the time of this publication, the equipment has been or is being received by many user units.

Graphical equipment for use with FT 8-J-3—including scale, graphical firing, M71 and scale, graphical firing, site, M72—has also been produced and sent to ordnance depots for issuance to the user units. The 8-inch howitzer units should start receiving this equipment early in 1962. Graphical equipment for use with FT 8-0-3 (ARTILLERY TRENDS, August 1961)—including scale, graphical firing, M85 and scale, graphical firing, site, M86—is awaiting general ordnance procurement and issue. As an interim measure, a limited quantity of graphical equipment for use with FT 8-0-3 will be mailed to all active duty 8-inch units to fulfill minimum requirements. An ordnance contract for production of this graphical equipment is expected shortly.

FT 105-H-6 and its associated graphical equipment (ARTILLERY TRENDS, March 1961) are now off the drawing board. This equipment will complete the revision of all caliber firing tables to the metric system in the artillery.

The new scale, graphical firing, site, for the 105-mm howitzer has the additional feature of an FDC sensing scale similar to the one on the back of DA Form 6-12 (Record of Precision Fire). The lower scale, at left in figure 29, shows the location of the sensing scale.

DATA SOURCE

DATA OBTAINED		105-mm Howitzer		155-mm Howitzer	
RANGE AND DEFLECTION	<p>FT 105-H4 Yds-OSA</p> <p>PROTRACTOR, FAN, RG DF (Aluminum) 16,500 yds SN 1290-266-6894 (Obsolescent)**</p> <p>GFT FAN M1 (Plastic) 15,000 meters SN 1220-335-4970 (Standard)</p>	<p>FT 105-H-6 M-ICAO</p> <p>PROTRACTOR, FAN, RG DF (Aluminum) 15,000 meters SN 1290-266-6890 (Standard)</p> <p>GFT FAN (Aluminum) To be evaluated by USAAB*</p>	<p>FT 155-Q-2 Yds-OSA</p> <p>PROTRACTOR, FAN, RG DF (Aluminum) 16,500 yds SN 1290-266-6894 (Obsolescent)**</p> <p>GFT FAN M2 (Plastic) 15,000 meters SN 1220-335-4971 (Obsolescent)</p>	<p>FT 155-Q-3 M-ICAO</p> <p>PROTRACTOR, FAN, RG DF (Aluminum) 15,000 meters SN 1290-266-6890 (Standard)</p> <p>GFT FAN (Aluminum) To be evaluated by USAAB*</p>	
ELEVATION	<p>GFT M39A1 Rule 1 and 2 (Obsolescent)**</p>	<p>SCALE, GRAPHICAL FIRING (GFT) Awaiting ORD "M" number, procurement, & issue.</p> <p>SCALE, GRAPHICAL FIRING (GFT, Proj, Illuminating) Awaiting BRL Data</p>	<p>GFT M43A1 Rule 1 and 2 (Obsolescent)**</p>	<p>SCALE, GRAPHICAL FIRING, M64 (GFT) Rule 1 and 2*** (Standard) SCALE, GRAPHICAL FIRING, M70 (GFT, Proj, Illuminating) Rule 1 and 2***</p>	
SITE	<p>GST M53A1 (Obsolescent)**</p>	<p>SCALE, GRAPHICAL FIRING, SITE (GST) Awaiting ORD "M" number, procurement, & issue.</p>	<p>GST M54 (Obsolescent)**</p>	<p>SCALE, GRAPHICAL FIRING, SITE, M67 (GST) (Standard)***</p>	

	FT 8-J-2 M-ICAO	FT 8-J-3 M-ICAO	FT 8-O-2 M-ICAO	FT 8-O-3 M-ICAO
RANGE AND DEFLECTION	PROTRACTOR, FAN, RG DF (Aluminum) 25,000 meters SN 1290-266-6891	PROTRACTOR, FAN, RG DF (Aluminum) 25,000 meters SN 1290-266-6891 (Standard)	PROTRACTOR, FAN, RG DF (Aluminum) 25,000 meters SN 1290-266-6891	PROTRACTOR, FAN, RG DF (Aluminum) 25,000 meters SN 1290-266-6891 (Standard)
ELEVATION	GFT FAN Not to be developed	GFT FAN (Aluminum) To be evaluated by USAAB*	GFT FAN Not to be developed	GFT FAN Not to be developed
SITE	GFT Rule 1 and 2 (Obsolescent)** Paper scales mailed to active and reserve units in Mar and Jul 1960 respectively.	SCALE, GRAPHICAL FIRING, M71 (GFT) Rule 1 and 2 Standard***	GFT Not developed	SCALE, GRAPHICAL FIRING, M85 (GFT) Rule 1 (Standard) Awaiting procurement, & issue.
	GST SITE (Obsolescent)** Paper scales mailed to active and reserve units in Mar and Jul 1960 respectively.	SCALE, GRAPHICAL FIRING, SITE, M72 (GST) (Standard)***	GST Not developed	SCALE, GRAPHICAL FIRING, SITE, M86 (GST) Rule 1 (Standard) Awaiting procurement, & issue.

* One standard aluminum GFT Fan with interchangeable aluminum ballistic scales to be developed for 105mm, 155mm, and 8-inch howitzers. Anticipate pilot completion by ORD in July 62.

** Present graphical equipment should be used until receipt of new graphical equipment.

*** In process of being issued to troops.

Figure 27. Current status of cannon graphical fire direction equipment (1 February 1962).

FREE ROCKETS 762-mm and 318-mm	
See FTR Categories Below M-ICAO	
SCALE, LOW LEVEL WIND, M78 FTR-762-A-2 AWAITING ORD PROCUREMENT & ISSUE	SCALE, LOW LEVEL WIND, M81 FTR 762-E-1 AWAITING ORD PROCUREMENT & ISSUE
SCALE, LOW LEVEL WIND, M80 FTR-762-B-2 AWAITING ORD PROCUREMENT & ISSUE	SCALE, LOW LEVEL WIND, M73 FTR 762-F-1 AWAITING ORD PROCUREMENT & ISSUE
SCALE, LOW LEVEL WIND, M79 FTR 762-C-1 AWAITING ORD PROCUREMENT & ISSUE	SCALE, LOW LEVEL WIND, FTR 762-G-1 AWAITING BRL DATA
SCALE, LOW LEVEL WIND, M74 FTR 762-D-1 AWAITING ORD PROCUREMENT & ISSUE	SCALE, LOW LEVEL WIND, FTR 762-H-1 AWAITING BRL DATA
	SCALE, LOW LEVEL WIND, FTR 318-A-1 AWAITING BRL DATA

Figure 28. Current status of graphical equipment for the free rockets (1 February 1962).

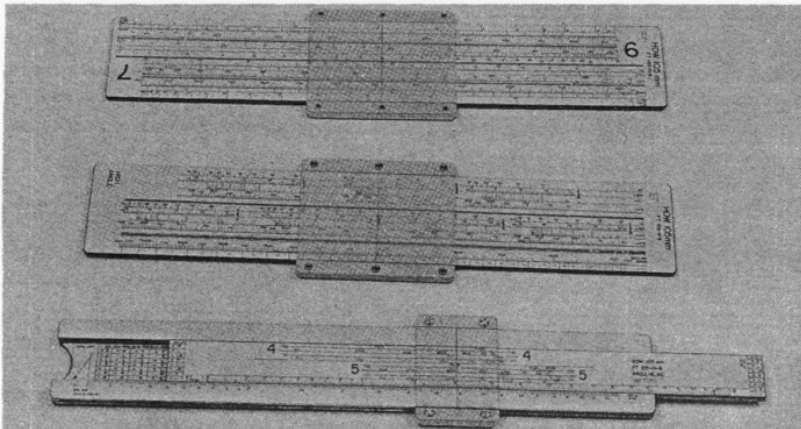

Figure 29. Upper and middle scales show charges 6 & 7 and high angle portion of FT 105-H-6. Lower scale shows portion of scale, graphical firing, site.

The addition of the sensing scale will satisfy the many requests received from the field and will be a handy reference in converting observer sensings to FDC sensings. Since this item is so new, no ordnance contract for production has been transacted. However, a limited quantity of the equipment is being sought for issue to active duty units as an interim measure to fulfill the minimum requirements until general issue can be made.

A graphical device for use with the 105-mm howitzer illuminating projectile will be developed as soon as data is available from the Ballistic Research Laboratories (BRL), Aberdeen Proving Ground, Maryland.

All the scales mentioned here can be purchased in limited quantity from the Book Department, US Army Artillery and Missile School. Graphical equipment based on FT 105-H-6 will be on sale shortly. Scales, graphical firing, based on FT 105-H-6, FT 155-Q-3, and FT 8-J-3 may be purchased for \$2.50 a set. Scales, graphical firing, based on FT 8-0-3 may be purchased for \$1.35. Scales, graphical firing, site, for all weapons cost \$2.25. Ordering by model number will expedite delivery.

To maintain the latest status of graphical equipment, you might wish to remove figures 27 and 28 from this issue and put them on your bulletin board, clipboard, or desk.

●

A GEM FOR THE BATTERY EXECUTIVE OFFICER

Do your gunners have difficulty finding the right aiming posts when they lay their howitzers during fire missions? Here is a way you can help them to reduce the possibility of using the wrong posts.

Make up small markers (about 6" × 8" is big enough) of sheet metal, masonite, or similar sturdy material. These markers should be painted red and white in a series of distinctive patterns, one pattern for each section. Place a clamp or spring clip on the back of each marker so that the markers can be attached to the near aiming posts. The clamps will permit the marker to be mounted high enough to be seen above any high grass which might be in the way.

When these markers are in use, all cannoneers should know their own section marker. These markers may also speed up checks made by the chief of section and safety officer.

Below is a suggested set of marker patterns. Do not use regular numbers; they might cause confusion if the 4th section, for example, were to occupy a position as Number 5 piece. Figure on Page 53.

—submitted by Captain Joe N. Gregg
1st How Bn, 10th Arty
APO 36
New York, N. Y.

Infantry, Armor, Mechanized . . .



Major L. M. Mitchell, Sr.
Communication/Electronics Department

In the November issue of ARTILLERY TRENDS, an article (page 48) discussed the communications systems of the new infantry, armored, and mechanized divisions. As pointed out in that article, the artillery communications systems for the three type divisions will be identical. However, some differences in equipment and tactics should be noted.

In the infantry and mechanized divisions the maneuver elements will use the infantry series radios and in the armored division the armor series will be used. The direct support field artillery battalions in the infantry and mechanized divisions will use the AN/PRC-10 and AN/VRC-10 radios to communicate with the supported maneuver elements, whereas the direct support battalions in the armored divisions will use the AN/PRC-8 and AN/VRC-8 radios.

As for tactical differences, the armored and mechanized division artillery units will be self-propelled and, in some instances, will have armored personnel carriers, whereas the infantry division artillery units will have wheeled vehicles only. The tactics of the faster-moving armored and mechanized divisions will necessitate placing more reliance on radio and less on wire.

Keeping these differences in mind, this article will go into a more detailed discussion of the radio and wire nets of the artillery battalions in these divisions. The systems presented here have been developed using only the equipment authorized by appropriate TOE.

RADIO

The direct support battalion will be required to operate four internal radio nets. These nets are the command/fire direction net (CF) (FM) and fire direction nets 1(F1), 2(F2), and 3(F3). As the title implies, the CF net will be used to process command traffic; however, fire direction traffic may be passed over this net. If this becomes necessary, fire direction traffic will take precedence over command traffic. Normally the battalion

commander, his executive officer, certain other staff officers, and the battery commanders and executive officers operate in this net.

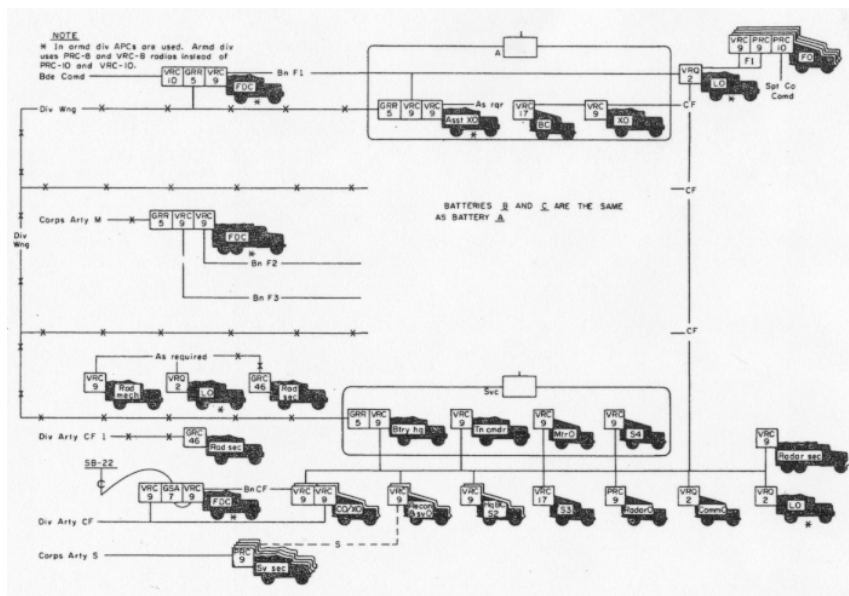

Figure 30. Type radio nets of a field artillery howitzer battalion, 105-mm.

The three fire direction nets will be used to process fire direction traffic. It is assumed that most units will assign a fire direction net to one particular battery, liaison officer, and forward observer group, for example, F1 to A battery, F2 to B battery, etc. A fire direction net will normally contain stations of a howitzer battery FDC, the battalion FDC, and a liaison officer and his forward observers. Since there will be from three to five forward observers on one net, there will be a need for an alternate channel, and for strict adherence to proper radio/telephone procedures. These are the four internal radio nets of a direct support field artillery battalion. In addition, the battalion and its batteries must operate in or monitor certain external radio nets.

The first external net is the brigade command net (FM). The battalion FDC operates an AN/VRC-8 or -10 (depending on the type of supported unit) in this net. Liaison and fire support coordination traffic is passed over the net between the brigade and the artillery battalion.

The division warning net is monitored with an AN/GRR-5 radio receiver by the battalion FDC, each howitzer battery FDC, and the service battery headquarters. Warnings of impending nuclear strikes, fallout patterns, air strikes, chemical, radiological, and biological attacks, and other warnings of an urgent operational nature are broadcast over the

division warning net. Each of the receiving stations must further disseminate these warnings over the internal communications systems of their particular units so that each soldier may be forewarned to take appropriate precautions.

The meteorological sections of the corps artillery target acquisition battalion and the division artilleries operate in the corps artillery meteorological net and broadcast meteorological data on an announced time schedule. The direct support battalion FDC's monitor this net using an AN/GRR-5. A study has recently been completed on the feasibility of the division artilleries transmitting metro data directly to the battalions over their command/fire direction nets (AM). If this system is adopted, the corps artillery meteorological net will be used by the target acquisition battalion and division artilleries' metro sections to coordinate metros and to exchange metro information. It will also serve as an alternate means of disseminating metro data.

The division artillery command/fire direction net 1(CF1) is an amplitude modulated (AM) net and is operated by division artillery to pass command and fire direction traffic to its direct support battalions. It is a radio teletypewriter net and has a cryptographic capability, as all stations are equipped with AN/GRC-46 radios. If the system mentioned in the preceding paragraph is adopted, this set will also be the primary means of disseminating metro data to those units not having a nuclear delivery capability.

The division artillery command/fire direction net (CF) (FM) is used by the division artillery commander to command and control his headquarters, and subordinate units both organic and attached. The direct support artillery battalion commander, his executive officer, and the battalion FDC each operate an AN/VRC-9 radio in this net.

Each forward observer must operate an AN/PRC-8 or -10 radio in the company command net of the company he is supporting. This permits the forward observer to be in direct communication with the company commander.

The corps artillery survey channel is not a formal radio net. It is a frequency authorized by corps artillery for the use of all survey sections operating throughout the corps artillery area. This net is used by survey personnel to coordinate their survey efforts and to exchange survey information.

These are the radio nets, internal and external, which a direct support artillery battalion must either operate in or monitor. Figure 30 shows the nets, operating stations, type radios used, and the types of vehicles in which the radios are mounted. Sufficient remote control equipment (AN/GRA-6) is authorized to permit remote control operation of appropriate radios.

WIRE

The wire system of the direct support howitzer battalion generally parallels its radio nets. To separate command traffic from fire direction

traffic, the battalion operates a command switchboard and a fire direction switchboard. In addition to separating the traffic, the two switchboards provide flexibility as alternate routes of communication for each other. The priority wire circuits are those that will be used for fire control and fire direction. The howitzer batteries are authorized one standard five-man wire team and the battalion headquarters battery is authorized three such teams. In addition, the liaison officer sections and forward observer sections have limited wire-laying capabilities.

A type battery wire system is shown in figure 31. Each howitzer section installs a circuit from the howitzer to the connecting switching

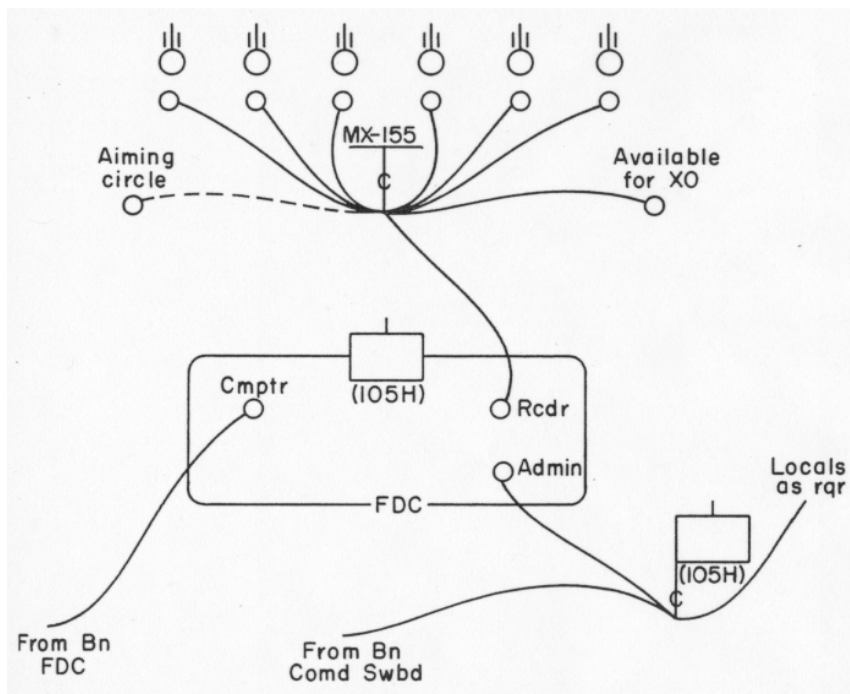

Figure 31. A type battery wire system.

group, MX 155/GT. A circuit is installed by the recorder from the battery FDC to the MX 155/GT. This system provides the executive officer with wire communications to each howitzer, and to his FDC. The battery wire teams must install a circuit from the battery FDC to the battalion FDC. This is the priority wire circuit for the battery. After the priority circuit has been installed, trunk lines are laid between the battalion and battery command switchboards. Administrative and other local lines are installed as time permits. The responsibility for communication between the battalion and the batteries rests with the battalion commander; however, the physical installation is normally assigned to the batteries.

Figure 32 shows a type battalion wire system. The priority wire circuits for the three wire teams of the headquarters battery are those from the FDC switchboard to the switchboards of the liaison officers

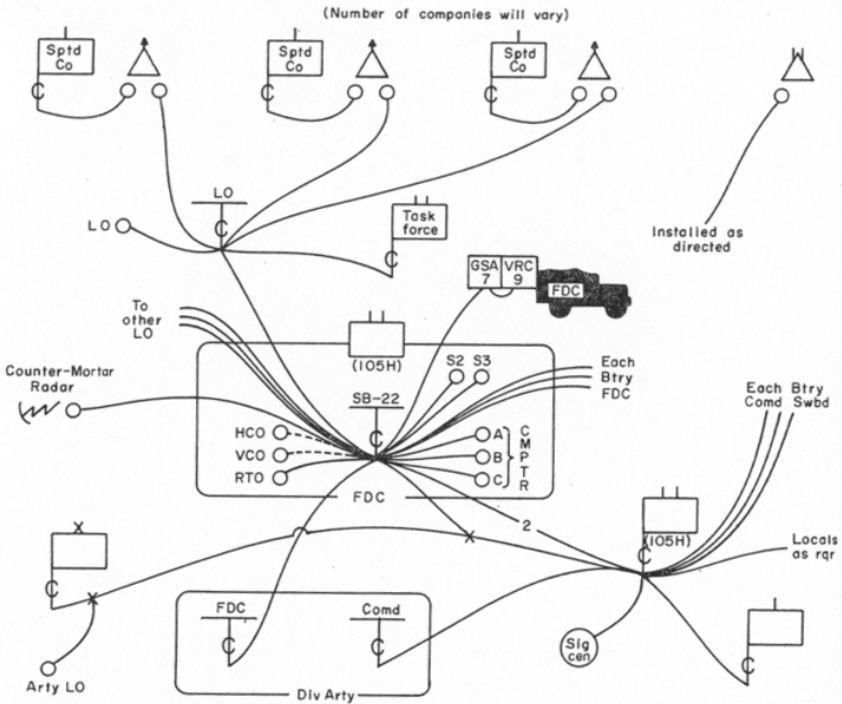

Figure 32. Type wire system for a FA howitzer battalion, 105-mm.

with the maneuver battalions (3 to 5) and from the battalion command switchboard to the command switchboard of the supported brigade. A simplex circuit is installed by the battalion wire team over the command line to provide the liaison officer at brigade with direct communications to the artillery battalion FDC. The switchboards of the liaison officers with the maneuver battalions will serve as forward switches for the forward observers. Normally the forward observer will lay a circuit back to his liaison officer's switchboard. If the distance is too great or if for some other reason he is unable to install this circuit, the battalion wire teams will have to assist. The liaison officer can assist; however, his assistance will be very limited since he is not authorized sufficient personnel or equipment to install long wire circuits. He is authorized two enlisted men and one vehicle to perform his normal liaison duties, supervise the activities of from three to five forward observers, and operate a switchboard on a twenty-four hour basis. For these reasons the liaison officer cannot be expected to install long wire circuits. The forward observer

is responsible for the installation of a wire circuit from his position to the command switchboard of the company he is supporting. This is his priority' circuit and it provides him not only with communications with the company commander, but is also an alternate route for transmission of fire requests, for example, from forward observer to the company, to battalion, to brigade, to the artillery battalion. The battalion wire teams must install a circuit from the battalion command board to the service battery and from the command board to the nearest signal center of the division area signal system. The battalion FDC switchboard. in addition to connecting the fire direction center lines with those from the batteries and the liaison officers with the maneuver battalions, will also serve as the terminal point for a circuit from the battalion's counter-mortar radar section. Circuits from reinforcing units will terminate at the FDC switchboard while circuits from adjacent units will terminate at the command board.

The communications system of the general support battalion (fig 33) does not greatly differ from that of the direct support battalion; however, there are some differences. The general support battalion operates two internal radio nets; they are both FM nets and are the battalion command/fire direction net and the battalion fire direction net. These nets serve the same purpose as the corresponding nets in the direct support battalion. The general support battalion and its batteries operate in the same external radio nets as the direct support battalion with the exception of the division artillery CF1 and the radio nets of the supported maneuver units. The battalion headquarters and the 8-inch battery operate in the division artillery CF2 net. The primary purpose of the CF2 net is to process nuclear fire missions; however, it also provides an AM radio command and conventional fire direction link between division artillery and the battalion. Figures 33 and 34 show the radio nets which the general support battalion must either operate in or monitor.

The wire system for the general support battalion is not so large or so complex as that of the direct support battalion. No forward observers or liaison officers are sent to maneuver elements; consequently, most of the wire circuits are in the battalion area. The priority wire circuits are those which deal with fire direction. Figure 35 shows a type battalion wire system and figure 36 shows a type wire system for the batteries.

HONEST JOHN

The field artillery missile battalion, Honest John, operates two internal radio nets. These nets are both FM and are the battalion command/fire direction net and the battalion fire direction net. The Honest John battalion operates in the same external nets as the 155-mm/8-inch howitzer battalion. Figure 37 shows the radio nets which the battalion will either operate in or monitor.

The wire system of the Honest John missile battalion, though relatively simple, is extensive. Normally the batteries must prepare several

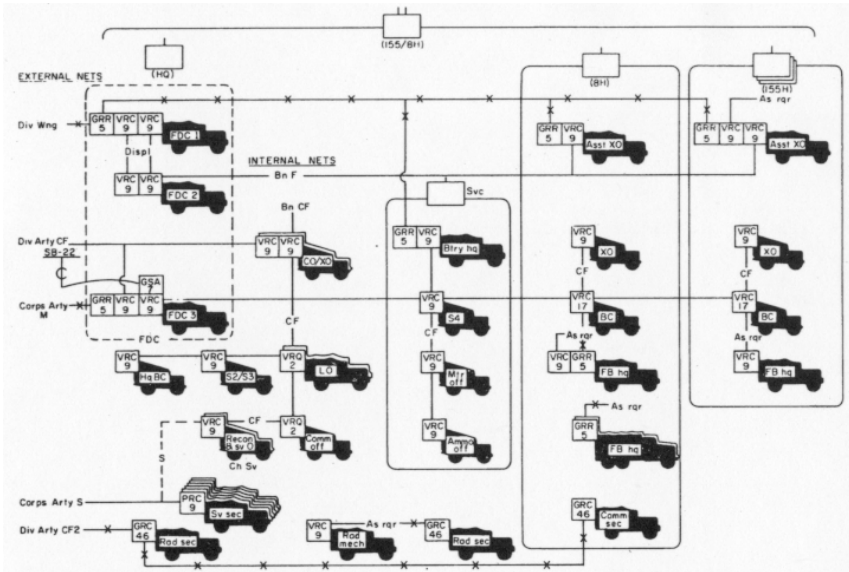

Figure 33. Type radio net, general support battalion, infantry division.

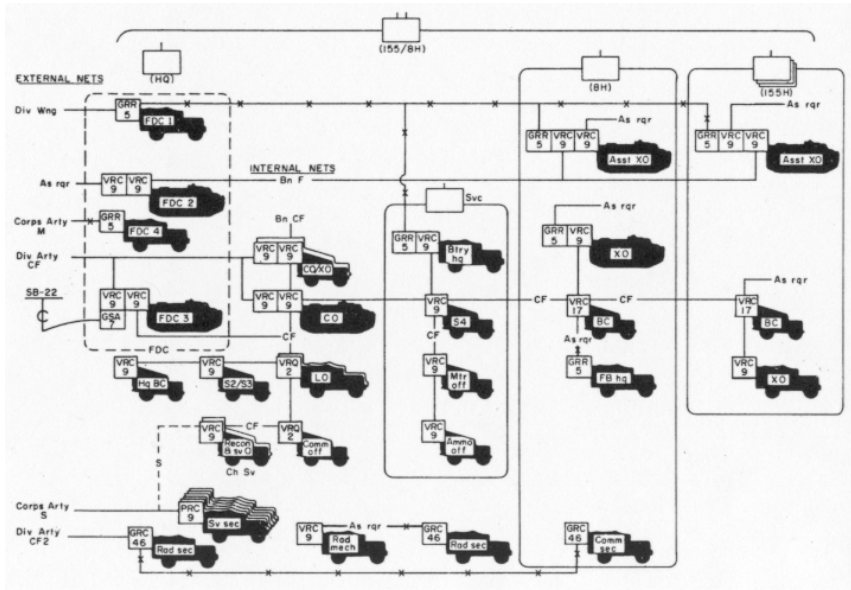

Figure 34. Type radio net, general support battalion, armored or mechanized division.

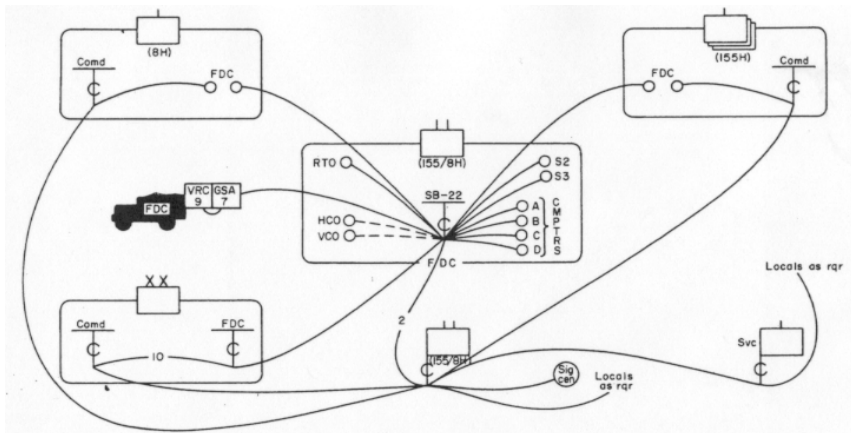

Figure 35. Type battalion wire system, general support battalion.

Note: 10 wire circuits are installed between the division artillery command switchboard and the division artillery FDC switchboard.

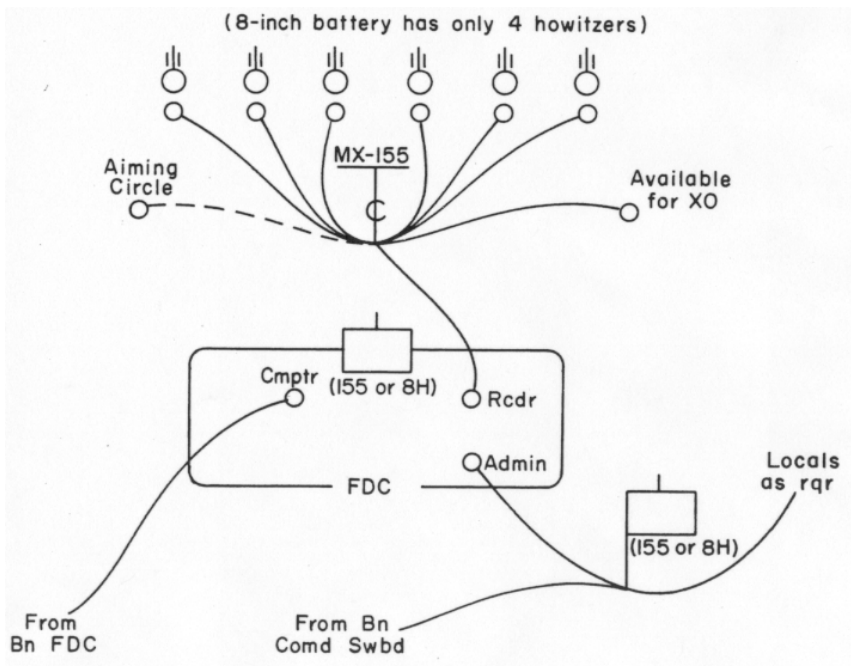

Figure 36. Type battery wire system, 155-mm or 8-inch, general support battalion.

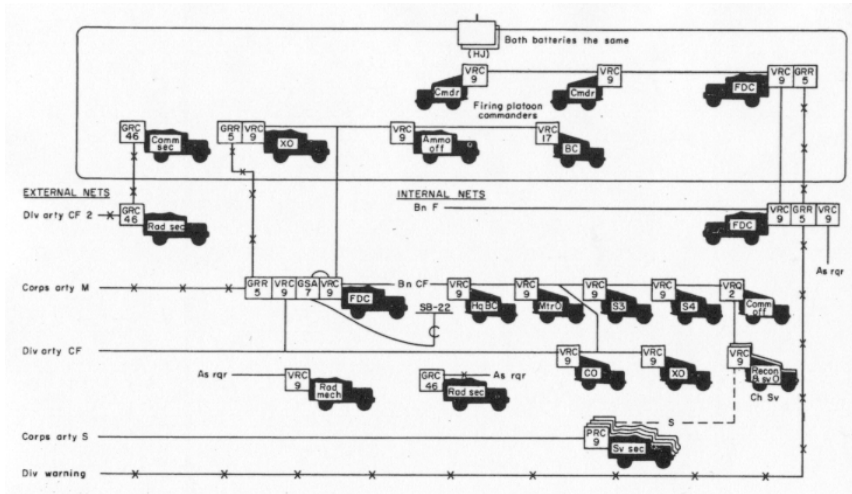

Figure 37. Type radio net, FA missile battalion, Honest John.

launcher positions for possible occupation. Preparation requires that a circuit be installed from the battery FDC to the fire control point of each of the prepared positions. Internal circuits of the firing positions

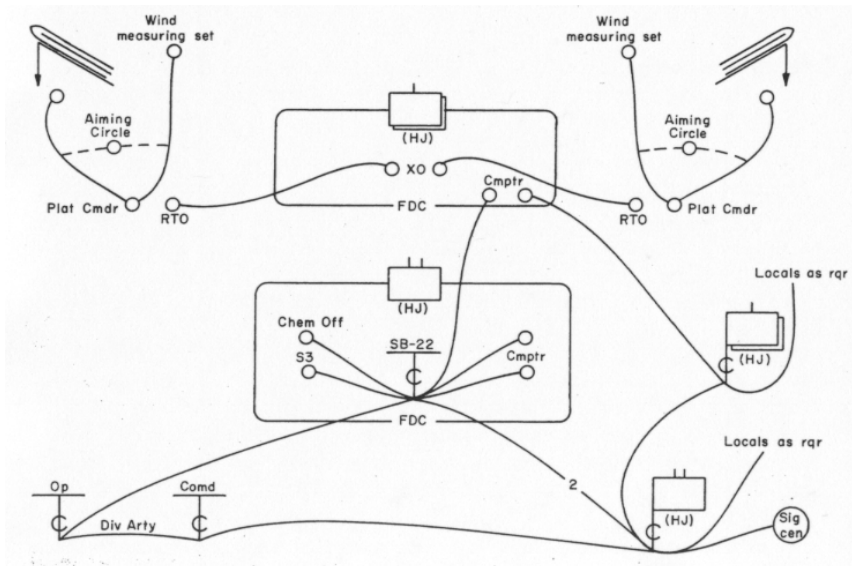

Figure 38. Type wire system, FA missile battalion, Honest John.

will be installed by personnel of the wind measuring and launcher sections when the position is occupied. This is a sizeable task for the one three-man wire team authorized each firing battery; consequently, they will occasionally require assistance from battalion. The battalion is authorized two five-man wire teams. The priority wire circuits for these teams are those circuits between the battalion and battery fire direction centers. The battalion must also install the circuits between the command switchboards of the battalion and the batteries, and a circuit from the battalion command board to the nearest signal center of the division area signal system. By entering the division area signal system, the Honest John battalion can reduce the number of wire circuits it would otherwise be required to install, particularly if the battalion is employed over a wide area. Figure 38 shows a type wire system for the Honest John battalion.

These are the communication systems of the artillery battalions organic to the infantry, mechanized, and armored divisions. Basically, the systems are the same in all three divisions, with the only differences being in the type radios used and the vehicles in which these radios are mounted. No longer must a "Redleg" learn a new communications system upon transfer from one type of division to another; artillery communications is nearing its goal of standardization.



Classes on commo systems ("Infantry Divarty" — CS 60; "Armor Divarty"—CS 84) are obtainable from the address on page 3.

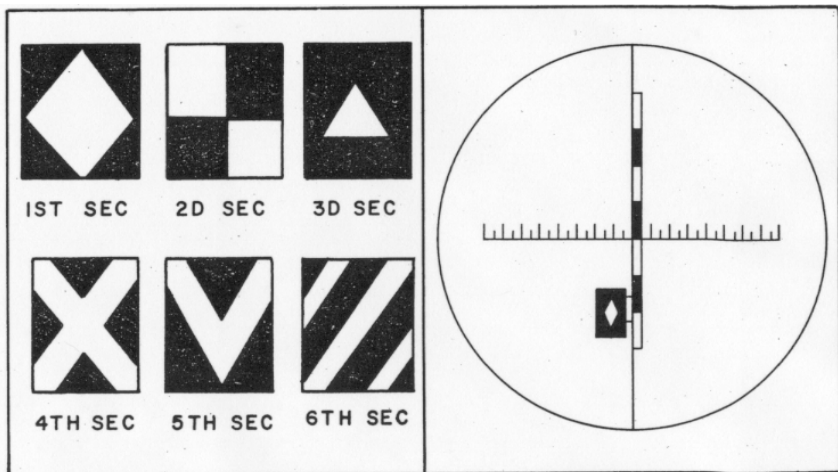

Explanation: page 43

Figure 39. This is one example of marker patterns. Individual units, of course, may devise their own patterns.

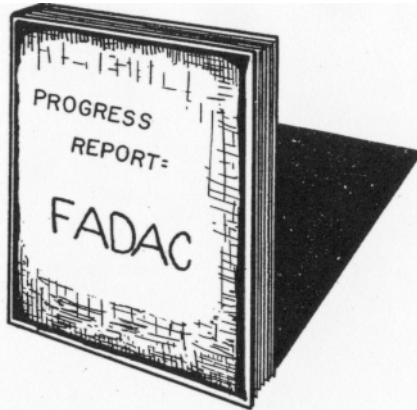

Captain Read E. Myers
Gunnery/Cannon/Rocket Department

During the past few years many of you have received briefings on FADAC, some of you have seen demonstrations, and many more of you have read about FADAC in ARTILLERY TRENDS (Sep 60). This article is intended to bring you up to date on FADAC development.

The prototype FADAC (fig 40) has completed the test phase given by both Aberdeen Proving Grounds and the US Army Artillery Board. The Board's recommendation that FADAC be type classified as Standard A and issued according to an approved basis of issue was approved by US Continental Army Command. Based on test conclusions, there will be some modification to FADAC in its production configuration. Several internal changes will be made to reduce the number of circuit boards and thus reduce the overall weight of the computer. The computer storage element will have an 8,192-word memory—twice the capacity of the prototype. There will also be a few changes on the front panel to facilitate operation. However, the computer, when produced, will appear essentially the same as its prototype.

The production contract has already been awarded. The initial production of 145 computers is expected to be in the hands of using units by October of this year. After production and subsequent testing, the computers will be loaded with the programs applicable to the units to which they will be sent, so that they will be ready for immediate use. Prior to receipt of the computers by the using units, key fire direction personnel will be trained, and a field manual covering the operation and maintenance of the computers will be published. The field manual, FM 6-(), will be entitled "Operation and Field Artillery Application of Gun Direction Computer M18." It is envisioned that this manual will contain, in separate chapters, complete instructions for all of the artillery applications for FADAC.

The artillery items of equipment for the FADAC system are being user-tested at the US Army Artillery Board now. These tests are expected

to be completed by March 1962, at which time the equipment will be type classified and a basis of issue determined. The complete FADAC equipment includes: the battery display unit (BDU), the gunnery officer's console (GOC), and the electrical tactical map (ETM).

The battery display unit is a small, lightweight, rugged device to be utilized at the executive officer's command post for the display of fire commands originating at the gunnery officer's console or for display of gun data generated by the computer program. Cost permitting, these units may be used at each gun position.

The gunnery officer's console is a small, lightweight, rugged device to be used in the battalion fire direction center for entry of fire commands to be transmitted to the firing batteries and for entry of appropriate items of information to the computer program (shell, fuze, charge). Both the battery display unit and the gunnery officer's console have an automatic checking feature to insure accurate transmission of the firing data. Additionally, there is an "acknowledge" signal from the battery display unit to inform the battalion fire direction center that the message has been received and that appropriate action is being taken. This signal extinguishes a flashing light on the gunnery officer's console that is first activated as the message is being sent to the battery display unit. In this way the checks and balances required in the transmission of firing data can be accomplished.

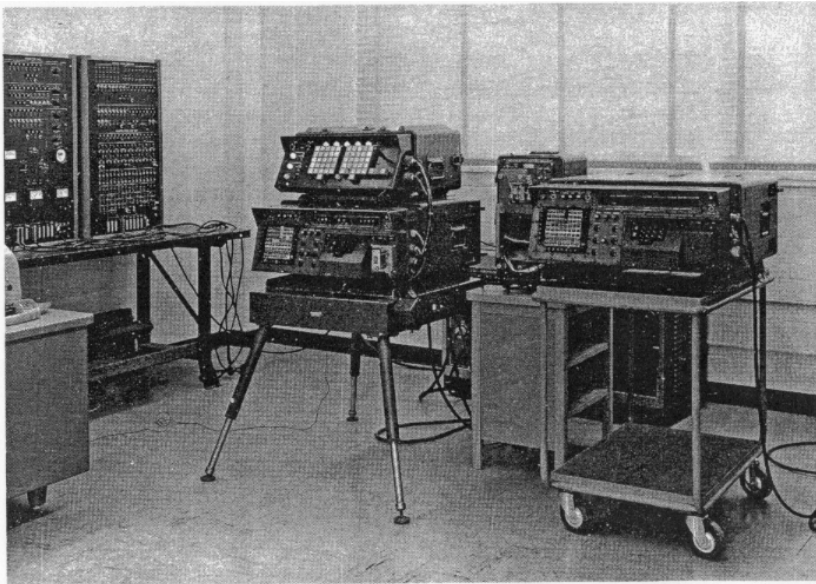

Figure 40. The latest in FADAC

The electrical tactical map is to be used in the battalion fire direction center for the display of map data. The display is under the control of

the gunnery officer's console, but map locations are calculated and acted on by means of a subroutine in the FADAC program.

From extensive test use of FADAC, definite operating procedures have been formed. One of the first questions asked by visitors is, "What will you do when the power fails" (or some similar question concerning the dependency of the FDC on the machinery)? The answer, of course, is obvious. We will revert to the manual capability. However, reliability during the test phase was measured in hundreds of hours between failures, and dependability is expected to increase in the production mode. The malfunctions vary in nature but basically can be categorized by an examination of the characteristics of the equipment.

EQUIPMENT FAILURES

The FADAC system is capable of partial automated operation, when one or more of its units is out of operation. Some examples of partial operation are:

- If a battery display unit is out of action, the data to that battery will be sent by voice communication, as presently accomplished.
- If the gunnery officer's console is out of action, the data to all batteries will be sent by voice communication, and the battalion will be without the services of the electrical tactical map.
- If the electrical tactical map is out of action, no other items will be affected. Since the map will probably be kept current with the situation and keeping two charts current is not practical, a special type of plotting needle is under study which will allow manual procedures.
- If the FADAC is out of action all of the other items are affected, and a complete reversion to the manual capability is required. It must be kept in mind, however, that with FADAC, the thinking S3 will be able to keep his graphical equipment up to the minute. As a new metro message is furnished, he can "shoot in" GFT settings and determine deflection corrections. Then, in the event the computer does become inoperable or, more likely, if one of the units is displaced during this period, he can immediately furnish a current set of "sticks".

It must be remembered that the computer and its accompanying system were not designed to replace fire direction personnel, nor were they intended to replace the S3. The whole purpose of the FADAC system is to provide you, the user, with a powerful tool in order that speed and accuracy, from the fire request through fire for effect, can be achieved in unobserved fires and maintained in observed fires.



"The day has twenty-four hours of duty; and it is possible to make use of the night also."

General Von Hindersin
Franco-Prussian War

PADA concept for . . .



Captain J. B. Tanzer
Gunnery/Cannon/Rocket Department

Little John is the newest and most accurate free rocket system in the US Army Field Artillery today. Lightweight, highly mobile, and transportable by aircraft organic to the field artillery, Little John is employed in a manner similar to conventional artillery. However, it is capable of delivering nuclear or conventional warheads, and it complements the heavier, longer range, Honest John free rocket.

At present, the Little John system is based on the spin-on-straight-rail (SOSR) concept. This means that the 318-mm Little John Rocket is spun on a straight rail launcher prior to ignition and launch. Bearings located in the front shoe barrel and the fin barrel of the rocket allow it to spin. The front shoe barrel and the fin barrel, which contain the front and rear shoes of the rocket, remain stationary and support the rocket on the launcher rail. A manually-wound spring motor on the launcher provides the power to spin-up the rocket through a launcher-rocket interconnect which automatically disengages when the rocket is fired. Rocket spin-up is initiated by pulling a lanyard which trips the launcher spring motor.

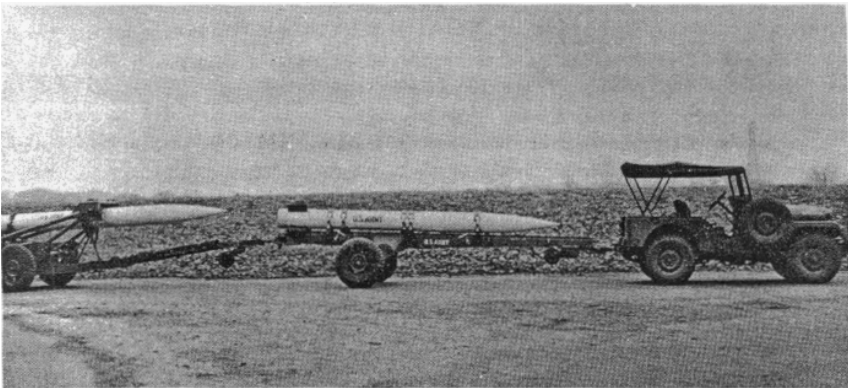

Figure 41. XM100 PADA launcher and XM522 trailer in traveling position.

The ignition system is automatically activated, and the rocket is fired when it reaches the required spin rate. Aiming the rocket for direction is accomplished in the same manner as for conventional artillery except that low level wind corrections to the aim must be applied prior to launch. The corrections are based on data obtained from a lightweight wind measuring set. (See ARTILLERY TRENDS, July 1960.)

Concurrent with the development of the Little John system based on the SOSR concept, research was conducted on a noninterfering basis on a new concept called PADA. The XM100 PADA launcher with its companion XM522 trailer towed in tandem behind a 1/4-ton truck is shown in figure 41.

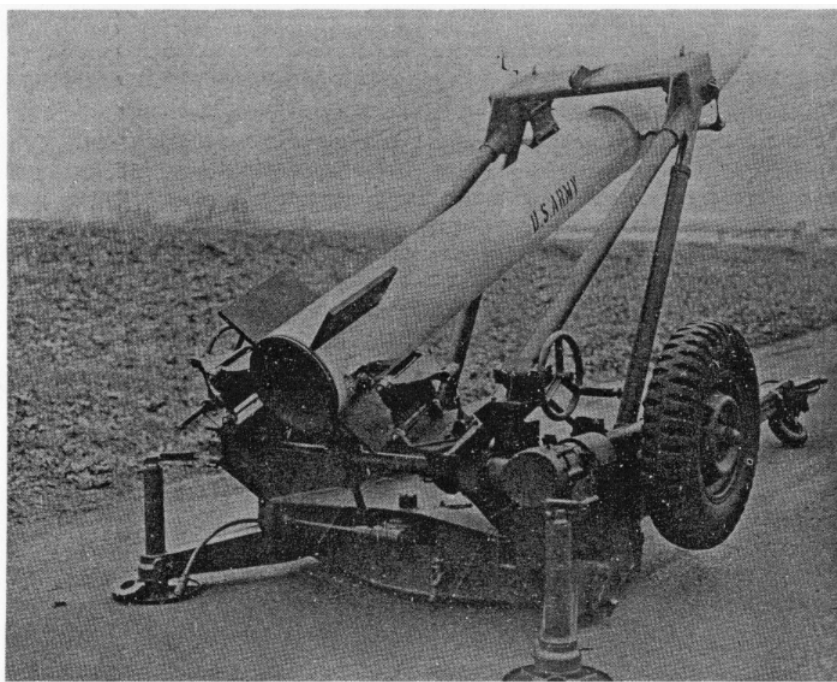

Figure 42. Launcher rocket: 318-mm, XM100 placed in firing position.

This equipment was developed during the research test program of the PADA concept. Details of the concept are classified, but it can be said that this concept offers further improvement in free rocket accuracy in addition to a number of other advantages. Principal among the advantages are the elimination of the need for low level wind corrections prior to launch with a resultant reduction in equipment and the number of crew members required, a substantial improvement in capability to withstand higher tow speeds under all conditions (improved, secondary, and cross-country roads), increased speed of employment resulting from

simplified emplacement (fig 42) and aiming procedures, more rugged equipment and a lower overall system weight.

Although the Little John is miniature in size, the field artillery is proud of this rugged weapon which can assert itself with destructive authority. Little John is scheduled for assignment to the airborne division artillery. For further information on the Little John organization refer to page 26.

GEM FOR THE FIRING BATTERY

Do your cannoneers have difficulty emplacing aiming stakes into hard ground? Figure 43 shows an emplacement rod that is easily fabricated and can be attached to an aiming stake to speed up their placement, especially in hard ground. The rod is two and one-half feet in length and is pointed at the bottom. The bottom handle is located at the middle of the rod and is used for applying foot pressure. The upper handle is used when the ground is soft enough to give beneath hand pressure. The emplacement rod is attached to the stake with a "U" clamp at the top and a ring at the bottom for the tapered point of the stake.

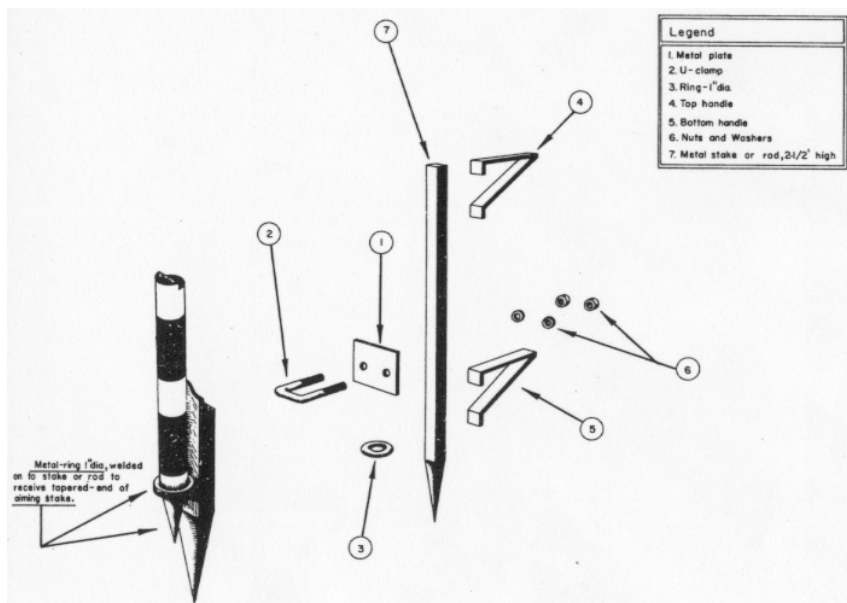

Figure 43. Emplacement rod for aiming stake.

—submitted by 1st Lt Walter A. Werner
"A" Btry, 5th How Bn
133d Artillery
Texas National Guard
36th Infantry Division



THE ARTILLERY WORLD

NEW WEAPONS DESIGNATIONS

The new fully-armored, full-tracked, aluminum self-propelled howitzers, 105-mm and 155-mm, have been redesignated with Ordnance "M" numbers. The T195E1, 105-mm howitzer is henceforth designated the M108, while the T196E1, 155-mm howitzer is to be known as the M109. The 155-mm auxiliary propelled howitzer, now in testing, has been given the experimental model designation, XM123.

HU-1D DEVELOPMENT

Bell Aircraft's HU-1D helicopter has recently completed its first flight. The aircraft is powered by a turbine engine developing 1,100 shaft horsepower, and has a cargo space of 220 cubic feet, 80 more than its predecessor, the HU-1B. HU-1D can carry a pilot and 12 fully-equipped battle troops, 50 percent more than the HU-1B. It was designed to meet Army requirements in brushfire wars—patrol, casualty evacuation, troop transport and cargo hauling in cabin or by external sling load. It is tailored to meet these requirements with compactness, low silhouette, and transportability by cargo plane.

The HU-1D is a member of the Iroquois helicopter series, an earlier model of which set six world helicopter flight records, including marks for speed (158 mph), and lift (19,000 feet in 8 minutes, 7.1 seconds). The new model will retain dynamic components of the HU-1B and use existing structural hardware to facilitate production tooling techniques.

NEW TURRET BEARING

A new turret bearing, involving an aluminum ring with plastic balls is in the offing for artillery self-propelled vehicles. With a promise of 60% weight reduction, this new system offers a significant advantage over present devices, particularly in view of the Army's current program of lightweight self-propelled artillery development.

If upcoming tests are successful, it is hoped that the aluminum-plastic combination can be broadened into the field of vehicle bearings.

CHINOOK

The HC-1B Chinook helicopter, planned replacement for the H-37A medium transport helicopter, was the subject of a recent contract (\$25 million) awarded by the Army.

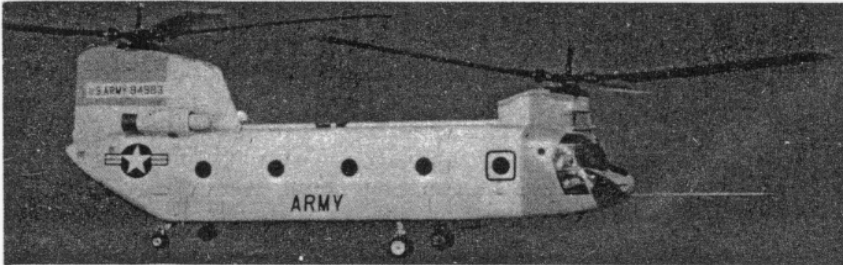

The Vertol Division of Boeing Airplane Company received the contract for the helicopter, which will have a lifting capability of three tons and will transport a crew of three plus 33 fully-equipped troops, or 24 litters.

Chinook will weigh 26,600 pounds and will be powered by two turbine engines (produced under separate contract by Lycoming Division, Avco Inc.), which will make the helicopter capable of a speed of 130 knots.

Deliveries under this contract will begin December, 1962.

IMPROVED ARMOR VEST

The Army Quartermaster Corps is developing an improved armor vest consisting of titanium plates and ballistic-resistant nylon. Known as the composite armor vest, the experimental protective garment covers a soldier's entire upper torso with a flexible armor of overlapping titanium plates stapled to the nylon material and is capable of stopping high-velocity fragments on the battlefield.

This new model gives ballistic protection to the neck with a six-ply collar of ballistic-resistant fabric, and offers more flexibility in the shoulder area by means of a series of small pivots.

The vest will be issued to all Army ground and flight personnel in a combat zone to reduce injuries from battlefield fragments.

ANOTHER PERSHING SUCCESS

The latest in the series of Pershing test missile firings was completed with all test objectives met. The test included a fully-instrumented inert warhead package. The missile was fired from its mobile erector-launcher as it would in the helicopter mode of delivery to a firing site in the field.

This latest success was followed shortly by the announcement of new contracts for continued work on Pershing development. The contracts totalled well over \$111 million. The Martin-Marietta Company, Orlando, Florida, is the prime contractor on the missile.

AN/PRC-25 PRODUCTION IS STARTED

The Army has awarded a contract for production of over 8,000 radio sets, AN/PRC-25. Developed by the Army to be back-pack carried, the AN/PRC-25 transistorized walkie-talkie will replace the current AN/PRC-8, 9, and 10 radios. Compact, versatile, and suited to the type of ground action foreseen in any possible future combat, from "brushfire" wars on up to general conflict involving large numbers of troops, it is capable of communicating on 920 FM channels.

For extreme simplicity of operation under conditions of darkness and combat, the controls of the walkie-talkie can be set so that at least two channels are always readily available. Advanced frequency control circuits and transistors give the new portable set the stability and reliability of much larger vehicular equipment.

The AN/PRC-25 was designed by the US Army Signal Research and Development Laboratory, Fort Monmouth, New Jersey. This radio is smaller than its predecessors, measuring $11 \times 11 \times 4$ inches, and is slightly lighter, weighing 17 pounds, 11 ounces. The AN/PRC-25 will be produced by the Radio Corporation of America.

SERGEANT COMPLETES TESTS

Final firings in the development program of the Army's Sergeant ballistic missile system have been conducted at White Sands Missile Range, New Mexico, in preparation for readying the Sergeant to replace the operational Corporal.

Successful firings recently tested the Sergeant and its ground support equipment in simulated battlefield conditions. All test objectives were met. In one test, a Sergeant was successfully fired from a mountain site and impacted on target several thousand feet lower and many miles distant in the desert.

One of the objectives of the final series of firings was to check firing procedures to be used in troop training.

RECENT ARMY CONTRACTS

Multi-million dollar contracts recently awarded by the Army called for production of 1,500 M-113 armored personnel carriers; 405 M-60 tanks; 2,000 two and one-half ton trucks; 17 H-23F helicopters; 5,600 one quarter ton utility trucks (M-151) and 18 Pershing Missile Trainers.

"Lastly, the greater part of the enemy, chiefly Russians, sought to pass over the ice. It was very thick, and five or six thousand men, keeping some kind of order, had reached the middle of the Satschan lake, when Napoleon, calling up the artillery of his guard, gave the order to fire on the ice. It broke at countless points, and a mighty cracking was heard. The water, oozing through the fissures, soon covered the floes, and we saw thousands of Russians, with their horses, guns, and wagons, slowly settle down into the depths. It was a horribly majestic spectacle which I shall never forget."

—from "The Sun of Austerlitz"
by General Marbot

MET MEET

The sixth meeting of the Group of Experts on Exterior Ballistics was held recently. The Artillery and Missile School was represented by an officer from the Meteorology Division of the Target Acquisition Department.

The ballistics of tube artillery and ballistic missiles were the fields of concentration in this meeting, with two primary areas of interest — the meteorological aspect and ballistic correction.

The group plans to conduct a series of studies of atmospheric properties and circulations in the future. It was felt, however, that meteorological equipment now in use by the artillery is adequate for present needs.

●

WIND CHILL CHART

Wind Velocity											
(KNOTS)											
(MILES)											
39	30	22	17	13	9	4	3	2	1	0	
45	35	25	20	15	10	5	3	2	1	0	
Temperature (Degrees Fahrenheit):											
90	89.5	89	88.5	88	88.75	87.5	87	86	84.5	83	
82	81	80.5	80	79.5	78	76	74	72.5	70	60	
72	71	69.5	68	67	65	60	57	53.5	47.5	23	
63	61	59	57	55	52	44.5	39	34.5	20	-11	
51	49	47	45	42.5	38	28	18.5	11	0	-27	
41	39	36	34	30.5	25	11	0	-9	-23.5	-38	
									Below	Below	
30	28	25	23	18	11	-5	-16.5	-40	-40	-40	
								Below			
20	18	14	11	6	-2	-19	-40	-40	"	"	
								Below			
10	7.5	3	0	-6	-15	-35	-40	"	"	"	
						Below					
0	-2.5	-8	-12	-18	-29	-40	"	"	"	"	
					Below						
-11	-14	-18	-23	-30	-40	"	"	"	"	"	
				Below							
-21	-24	-30	-35	-40	"	"	"	"	"	"	
-32	-35	-40	-40	"	"	"	"	"	"	"	

Instructions for use of the table:

1. First, obtain the temperature and wind velocity forecast data.
2. Locate the number at the top corresponding to the expected wind speed (or the number closest to this).
3. Read down this column until the number corresponding to the expected temperature (or number closest) is reached.
4. From this point follow across to the right on same line until last number is reached under column marked zero (0) wind speed.
5. This is the equivalent temperature reading. Example: weather information gives expected temperature (at given time such as midnight) to be 35°F and expected wind speed (at same time, midnight) to be 20 miles per hour (mph). Locate the 20 mph column at the top, follow down this column to the number nearest 35°F. The nearest number is 34°F. From this point, move all the way to the right on same line and find the last number, which is -38°F. This means that with a temperature of 35°F and a wind of 20 mph, the effect on all exposed flesh is the same as -38°F with no wind.

Explanation: page 31

Figure 44. Wind chill chart.

CURRENT RESIDENT COURSE SCHEDULE

Listed below are the courses to be given at the US Army Artillery and
Missile School during the period 1 March 1962 through 30 June 1962.

Course	Cl Nr	Report	Start	Close	Input
Field Artillery Officer Orientation (6-A-C20)	14-62	19 Mar 62	23 Mar 62	17 May 62	90
	15-62	2 Apr 62	6 Apr 62	1 Jun 62	90
	16-62	16 Apr 62	20 Apr 62	14 Jun 62	90
	17-62	30 Apr 62	4 May 62	28 Jun 62	91
	18-62	28 May 62	1 Jun 62	26 Jul 62	91
	19-62	11 Jun 62	15 Jun 62	9 Aug 62	91
Artillery Officer Career (6-A-C22)	4-62	21 Mar 62	26 Mar 62	21 Dec 62	198
Associate Field Arty Officer Career (6-A-C23)	4-62	19 Mar 62	22 Mar 62	27 Jul 62	103
Fld Grade Officer Refresher (Res Comp) (6-A-C11)	2-62	4 Mar 62	5 Mar 62	16 Mar 62	56
Div Arty Staff Officer Refresher (6-A-F5)	3-62	8 Apr 62	9 Apr 62	14 Apr 62	35
Senior Field Arty Officer (6-A-F6)	3-62	20 May 62	21 May 62	2 Jun 62	19
Arty Survey Officer (6-A-1183)	3-62	8 May 62	11 May 62	6 Jul 62	39
Corporal Officer (6-A-1190A)	4-62	9 Apr 62	12 Apr 62	14 Jun 62	12
Little John Officer (6-B-1187B)	5-62	11 Mar 62	12 Mar 62	24 Mar 62	15
Arty Communications Officer (6-A-0200)	3-62	1 May 62	2 May 62	7 Aug 62	36
Arty Motor Transport (6-B-0600/6-B-0606)	2-62	7 Mar 62	9 Mar 62	4 May 62	44
Field Artillery Officer Candidate (6-N-F1)	5-62	9 Apr 62	16 Apr 62	18 Sep 62	54
	6-62	4 Jun 62	11 Jun 62	13 Nov 62	54
FA Officer Candidate (Res Comp) (6-N-F2)	2-62	17 Jun 62	20 Jun 62	1 Sep 62	110
Nuclear Projectile Assembly (6-D-142.1)	3A-62	4 Mar 62	5 Mar 62	9 Mar 62	23
	4-62	8 Apr 62	9 Apr 62	14 Apr 62	24
	4A-62	6 May 62	7 May 62	11 May 62	24
Rocket Nuclear Warhead Assembly (6-D-147.2)	10-62	18 Mar 62	19 Mar 62	26 Mar 62	19
	11-62	1 Apr 62	2 Apr 62	9 Apr 62	19
	12-62	29 Apr 62	30 Apr 62	7 May 62	16
	13-62	3 Jun 62	4 Jun 62	11 Jun 62	17
Arty Ballistic Meteorology (6-N-103.1)	6-62	13 Apr 62	19 Apr 62	29 Jun 62	42
Weather Equipment Maint (6-N-8219/205.1)	*6-62	1 Apr 62	3 Apr 62	12 Jul 62	13
* All allied students in this class, extended 1 week.					
FA Radar Maintenance (6-N-1121/211.3)	2B-62	14 Mar 62	19 Mar 62	29 Oct 62	29
	3-62	13 Jun 62	15 Jun 62	13 Feb 63	30
Corporal Fire Control System Maint (6-N-1186/215.1)	2-62	12 Apr 62	16 Apr 62	21 Nov 62	13
	3-62	7 Jun 62	11 Jun 62	30 Jan 63	13
Corporal Nuclear Warhead Assembly (6-D-F13)	4-62	7 May 62	8 May 62	17 May 62	12
Little John Firing Btry (6-R-F——)	5-62	11 Mar 62	12 Mar 62	24 Mar 62	20

Sergeant Missile Battery (6-N—)	1A-62	27 Mar 62	29 Mar 62	11 May 62	25
	2-62	18 Jun 62	20 Jun 62	3 Aug 62	30
Artillery Survey Advanced (6-R-153.1)	7-62	22 Mar 62	27 Mar 62	18 May 62	68
	7A-62	19 Apr 62	24 Apr 62	15 Jun 62	40
	8-62	4 Apr 62	9 Apr 62	1 Jun 62	68
	9-62	31 May 62	5 Jun 62	27 Jul 62	68
Arty Flash Ranging (Advanced) (6-R-154.1)	2-62	15 May 62	17 May 62	27 Jun 62	30
Arty Sound Ranging (Advanced) (6-R-155.2)	2-62	19 Mar 62	21 Mar 62	15 May 62	30
Field Artillery Radar Operation (6-R-156.1)	7-62	20 Mar 62	22 Mar 62	29 May 62	38
	8-62	23 Apr 62	25 Apr 62	3 Jul 62	38
	9-62	27 May 62	29 May 62	7 Aug 62	38
Corporal Mechanical Materiel Maintenance (6-R-164.3)	3-62	7 Mar 62	8 Mar 62	2 May 62	14
Redstone Mechanical Materiel Maintenance (6-R-169.1)	1-62	17 May 62	21 May 62	12 Jul 62	6
Artillery Radio Maintenance (6-R-313.1)	16-62	4 Mar 62	6 Mar 62	11 Jun 62	40
	17-62	18 Mar 62	20 Mar 62	25 Jun 62	40
	18-62	1 Apr 62	3 Apr 62	10 Jul 62	40
	19-62	15 Apr 62	17 Apr 62	24 Jul 62	40
	20-62	29 Apr 62	1 May 62	7 Aug 62	40
	21-62	13 May 62	15 May 62	21 Aug 62	40
	22-62	27 May 62	29 May 62	5 Sep 62	40
	23-62	10 Jun 62	12 Jun 62	18 Sep 62	40
Artillery Communication Supervisors (6-R-313.6)	3-62	12 Jun 62	14 Jun 62	27 Sep 62	40
Artillery Track Vehicle Maintenance (6-R-632.1)	14-62	18 Mar 62	20 Mar 62	31 May 62	64
	15-62	1 Apr 62	3 Apr 62	14 Jun 62	64
	16-62	15 Apr 62	17 Apr 62	28 Jun 62	64
	17-62	29 Apr 62	1 May 62	12 Jul 62	64
	18-62	13 May 62	15 May 62	26 Jul 62	64
	19-62	27 May 62	29 May 62	9 Aug 62	64
	20-62	10 Jun 62	12 Jun 62	23 Aug 62	64
Pershing Specialist (6-N—/163.2)	1-62	22 Jun 62	26 Jun 62	24 Oct 62	28

A GEM FOR THE BATTERY EXECUTIVE OFFICER

Do you have difficulty in keeping all the information required for the executive officer's report readily accessible? Shown below (fig 45) is an example of a form entitled "EXECUTIVE OFFICER'S REPORT AND PERTINENT DATA". This form simplifies some of the duties of the battery executive officer. Often the information contained on the form is kept on scratch paper and is easily misplaced. The executive officer will probably find that using this form increases his speed in the occupation of position and preparation to fire. In addition, this form may be of assistance to the safety officer.

If practicable, a carbon copy can be made and one copy sent to the battalion fire direction center, thereby saving time in transmitting the information by wire. If the position area is visited by the battalion commander, most of the necessary information of interest is contained on the form for his inspection. An SOP may even be instituted that this form be filed with the recorder's sheets for this particular gun position as a permanent record. The battery may occupy the same position at some other time and the information obtained initially would be very helpful.

(Turn over)

**EXECUTIVE OFFICER'S REPORT
AND PERTINENT DATA**

DATE: 26 July 61

ORIENTING AIMING CIRCLE

SAFETY DIAGRAM SKETCH

DECLINATION CONSTANT 49

ADD 6400 *m* IF NECESSARY 6449

MINUS THE GRID AZIMUTH 5100

DEFLECTION SET ON A.C. 1349

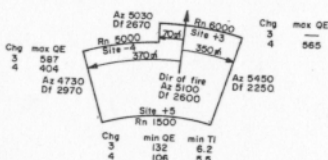

EXECUTIVE OFFICER'S REPORT

BATTERY IS LAID. AZIMUTH 5100 OR ORIENTING ANGLE
DEFLECTION 2600

MINIMUM QUADRANT ELEVATION(S) FOR: For Fz M51A4, M300A1
CHARGE 3, 132 CHARGE 4, 106 CHARGE.....
CHARGE..... CHARGE..... CHARGE.....

DISTRIBUTION OF PIECES:

NUMBER 1 75 METERS (RIGHT-LEFT) 50 METERS (BEHIND-
IN FRONT OF) BATTERY CENTER.

NUMBER 2 60 METERS (RIGHT-LEFT) 10 METERS (BEHIND-
~~IN FRONT OF~~) BATTERY CENTER.

NUMBER 3 30 METERS (RIGHT-LEFT) 20 METERS (BEHIND-
~~IN FRONT OF~~) BATTERY CENTER.

NUMBER 4 ON LINE METERS (RIGHT-LEFT) 30 METERS (BEHIND-
IN FRONT OF) BATTERY CENTER.

NUMBER 5 50 METERS (RIGHT-LEFT) 20 METERS (BEHIND-
IN FRONT OF) BATTERY CENTER.

NUMBER 6 75 METERS (RIGHT-LEFT) 40 METERS (BEHIND
~~IN FRONT OF~~) BATTERY CENTER.

ADDITIONAL DATA

WEIGHT OF PROJECTILE 2 SQUARES, POWDER TEMPERATURE
70, MAXIMUM ELEVATION (H.A. FIRE) —

REMARKS: Co-ord of Btry Center (559537.0-3844710.3)

Height 376.5 Meters. GFT "A" Chg. 4 Lot X Rn 3250

El 258. Ti 14.7 (Reg pt Nr 1)

Safety Officer - Lt Thompson, Hq 4th How Bn, 12th Arty

Figure 45. The Executive Officer's Report.

This form is intended as a guide only, and individual units may of course change it to meet their own needs.

—submitted by 1st Lt John J. McCracken
A Btry, 4th How Bn, 12th Arty
Hartwell, Ga.

STATUS OF TRAINING LITERATURE

1. The following training literature is under preparation or revision by the US Army Artillery and Missile School:

- A. FIELD MANUALS (FM):
 - 6-121 Field Artillery Target Acquisition
 - 6-() 8-inch Howitzer, M110, SP
 - 6-() 175-mm Gun, Motor Carriage, M107
 - 6-() Operation and Maintenance of Field Artillery Data Automatic Computer (FADAC)
 - 6-() 115-mm Multiple Rocket Launcher M91, and Toxic Rocket M55
 - 6-() FA Missile Battalion, Sergeant (U)
 - 6-() FA Missile, Sergeant (U)
- B. TECHNICAL MANUALS (TM):
 - None
- C. ARMY TRAINING PROGRAMS (ATP):
 - 6-545 Field Artillery Missile Battalion, Corporal
 - 6-585 Field Artillery Missile Battalion, Lacrosse
 - 6-630 Field Artillery Missile Battalion, Redstone
- D. ARMY TRAINING TESTS (ATT):
 - 6-4 Field Artillery Target Acquisition, Headquarters and Headquarters Battery
 - 6-16 FA Battalions, Gun or Howitzer, Heavy
 - 6-117 Field Artillery Howitzer Battery, Light or Medium
 - 6-137 FA Howitzer Battery, 8-inch, Infantry Division
 - 6-() Field Artillery Target Acquisition Battery

2. Training literature submitted to USCONARC:

- FM 6-10 Field Artillery Communications
- FM 6-15 Artillery Meteorology
- FM 6-20-2 FA Techniques
- FM 6-25 FA Missile Battalion, Redstone (U)
- FM 6-35 FA Missile, Redstone
- FM 6-36 FA Missile, Redstone Firing Procedures
- FM 6-40 Changes 1, Field Artillery Gunnery
- FM 6-56A FA Missile Battalion (Battery), Little John Rocket (U)
- FM 6-61 Changes 2, FA Missile Battalion, Honest John Rocket
- FM 6-61A FA Missile Battalion, Honest John Rocket (U)
- FM 6-75 Changes 1, 105-mm Howitzer, M2 Series, Towed
- FM 6-81 155-mm Howitzer, M1, Towed
- FM 6-92 155-mm Howitzer, M44, SP
- FM 6-120 FA Target Acquisition Battalion and Batteries
- FM 6-140 The Field Artillery Battery
- FM 6-73 Field Artillery Graphical Firing Equipment

FM 6-() Radar Set, AN/TPS-25
 ATP 6-100 Field Artillery Unit
 ATP 6-302 FA Rocket Units (Honest John, Little John)
 ATP 6-555 FA Missile Battalion, Sergeant
 ATP 6-575 FA Target Acquisition Battalion

3. Training literature at the Government Printing Office:

ATT 6-155 FA Howitzer Battalion, Light, Towed or SP

4. Training literature recently printed:

FM 6-20-1 Field Artillery Tactics
 FM 6-59 Changes 1, FA Rocket, Honest John, with Launcher M386
 FM 6-60 Changes 1, FA Rocket, Honest John, with Launcher M289
 FM 21-13 The Soldiers Guide
 TM 6-231 Seven Place Logarithmic Tables (October 1961)
 TM 6-300-62 Army Ephemeris for 1962
 ATP 6-558 Searchlight Batteries
 ATT 6-165 FA Howitzer Battalion, Medium, Towed or SP
 ATT 6-175 FA Missile Battalion, Honest John and Little John Rocket

Note: TM 6-231, Seven Place Logarithmic Tables (Oct 1961).
 Survey personnel note that Table II (pp 403-492 incl)
 must be read from right to left.

NOTE: ATT 6-155 and ATT 6-165 will supersede ATT 6-5 and ATT 6-116
 when all divisional artillery units have been reorganized under ROAD.

5. Artillery training films currently under production and scheduled for release during calendar year 1962:

318-mm Rocket
 Part I. Introduction to the system
 Part II. Description of equipment
 Part III. Loading, preparation for action, firing, and march order
 Field Artillery, RSOP
 Part I. Deliberate
 Part II. Rapid

6. Artillery training films currently under production and scheduled for release during calendar year 1963:

The 762-mm Rocket
 Part I. Introduction to the system
 Part II. Mechanical assembly and electrical checkout
 Part III. Loading, preparation for action, firing, and march order
 Field Artillery Target Acquisition Battalion
 The Infantry Division Artillery Forward Observer

7. Artillery training films production completed and scheduled for release in calendar year 1962:

Ground Surveillance Radar, AN/TPS-25

Part I. Theory, installation and operation

Part II. Moving target detection

Counter mortar Radar AN/MPQ-4A

Part II. Preparation and performance checks

Laying the Field Artillery Battery

8. Artillery training films scheduled for production and release during calendar year 1962:

None

9. Artillery training films recently released:

Lacrosse Battalion Assembly Section—Crew duties in prepare for action, checkout and assembly, and march order (TF 6-3103) (C) (37 minutes)

10. Status of Army Subject Schedules (MOS):

A. UNDER PREPARATION OR REVISION BY THE US ARMY ARTILLERY AND MISSILE SCHOOL:

ASubjScd 6-104 MOS Technical Training of the Field Illumination Crewman

ASubjScd 6-156 MOS Technical Training of the Radar Crewman

ASubjScd 6-161 MOS Technical Training of the FA Missile Crewman (Sergeant)

ASubjScd 6-166 MOS Technical Training of the FA Missile Crewman (Lacrosse)

ASubjScd 6-167 MOS Technical Training of the FA Missile Fire Control Crewman (Lacrosse)

B. SUBMITTED TO USCONARC:

None

C. AT GOVERNMENT PRINTING OFFICE:

None

D. RECENTLY PUBLISHED:

None

11. Status of Army Subject Schedules (Non-MOS):

A. UNDER PREPARATION OR REVISION BY THE US ARMY ARTILLERY AND MISSILE SCHOOL:

ASubjScd 6-5 Communications training for sections and platoons

ASubjScd 6-8 Counterbattery Operations

ASubjScd 6-9 Counter mortar Operations

ASubjScd 6-10 Field Artillery Radar Operations

ASubjScd 6-11 Defense of Artillery Position Areas

ASubjScd 6-17 Liaison

B. SUBMITTED TO USCONARC:

None

C. RECENTLY PUBLISHED:

None

ARTILLERY INFORMATION LETTERS

The following artillery information letters containing items of technical nature have been published by the US Army Artillery and Missile School since the NOVEMBER 1961 issue of ARTILLERY TRENDS. Distribution is made *only* to the units and their controlling headquarters which are authorized the equipment discussed in these letters:

HONEST JOHN INFORMATION LETTER NUMBER 28 (CRD)
dated 28 December 1961

HONEST JOHN INFORMATION LETTER NUMBER 29 dated 29
December 1961

LACROSSE INFORMATION LETTER NUMBER 17 (C) dated 29
November 1961



MISSILE MARKINGS

Garish colors, candy stripes, barber pole and checkerboard patterns painted on missiles by test engineers of the US Army Ordnance Missile Command and its elements are a prime means of determining how the missiles act in flight.

Viewing films of test firings, missile scientists and technicians study the paint patterns to determine any unusual motion of the missile. They spend hours poring over high-speed photography. The missile markings convey a clear message to those who "read" them.

Operational missiles are not so conspicuous. Missiles issued to troops go dressed in olive drab. A camouflage kit is issued with each missile. Letters are painted on the missiles to be most easily read in the position from which the missile normally is fired; that's why "US Army" reads vertically on some missiles and horizontally on others.

The Army discourages other markings but a distinctive insignie has been approved for at least one missile. The brand new Pershing ballistic missile is authorized to wear four stars on its sides, the insignie of rank of its namesake, General of the Armies John J. Pershing.

"The battlefield achievements of the artillery arm have enhanced the prestige of the entire American Army as well as its own reputation."

—Major General Harry F. Hazlett
In official correspondence June 1943

**ALPHABETICAL SUBJECT INDEX for
ARTILLERY TRENDS 1961
ISSUES OF MARCH, JUNE, AUGUST AND NOVEMBER**

SUBJECT	ISSUE	PAGE
AFAOCC		
Preparation for Nuclear Weapons Employment Subcourse	Nov 61	47
The Airborne Division		
Anytime to Anyplace and Fight— The Airborne Division	Mar 61	13
Aircraft		
Anytime to Anyplace and Fight— The Airborne Division	Mar 61	15-18
The Intelligence Chain— Strong as its Weakest Link	Mar 61	57
Air-Ground Communications	Nov 61	25
Ammunition		
Artillery Ammunition—Fuzes and Boosters.....	Jun 61	31
155-mm Illuminating Shell, T72E1 (newsnote).....	Nov 61	55
AN/GRC-50 Radio		
Anticipated production (newsnote).....	Nov 61	56
AN/MPQ-4		
The Intelligence Chain— Strong as its Weakest Link	Mar 61	65
AN/MPQ-29		
Artillery's Candid Camera—SD-1 Drone	Mar 61	3
AN/PPS-4		
Anytime to Anyplace and Fight— The Airborne Division	Mar 61	29
AN/TPS-21		
Anytime to Anyplace and Fight— The Airborne Division	Mar 61	29
AN/TPS-25		
The Intelligence Chain— Strong as its Weakest Link	Mar 61	65
In an M-257 APC	Aug 61	60
AN/TSC-18, 19, 20		
Mobile communications units	Aug 61	59

SUBJECT	ISSUE	PAGE
AN/USD-1		
Artillery's Candid Camera—The SD-1 Drone	Mar 61	3
Armor Group		
Your Sunday Punch—The Armor Group	Jun 61	23
Armored Personnel Carrier M59		
The M59 as a Carrier for 75-mm Pack Howitzer	Aug 61	51
Armored Personnel Carrier M113		
Issue to Troops (newsnote)	Nov 61	58
Atomic Burst Simulator		
Filler	Aug 61	43
Blue Water Missile		
British Field Artillery	Aug 61	13
Boosters		
Artillery Ammunition—Fuzes and Boosters	Jun 61	31
Boresighting		
All Weather, Night-Time—Boresighting Devices	Aug 61	44
British Artillery		
The Queen's Gunners—British Field Artillery	Aug 61	8
Cannon Correlation		
Concept of Caliber Coordination— Cannon Correlation	Jun 61	8
Click Sights		
Point-Blank Defense—Direct Fire	Jun 61	19
Communications Systems		
County Fair Communications	Jun 61	14
In the Jungle	Aug 61	28
Air-Ground Communications	Nov 61	25
Preventive Maintenance of Communications Equipment	Nov 61	41
Communications Systems in the New Divisions	Nov 61	48
A Gem for the Communications Officer	Nov 61	52
A Gem for Communications Personnel	Nov 61	60
Counter-Guerrilla Action		
Part I The Guerrilla—Special Warfare	Aug 61	16
Direct Fire		
Point-Blank Defense—Direct Fire	Jun 61	17

SUBJECT	ISSUE	PAGE
Drone		
Artillery's Candid Camera—The SD-1 Drone	Mar 61	3
Entac		
French Antitank Weapon, Newsnote.....	Aug 61	59
ES-29—Mobile Photographic Darkroom		
Artillery's Candid Camera—SD-1 Drone	Mar 61	3
Extension Courses		
AFAOCC Nuclear Weapons Employment Subcourse Preparation.....	Nov 61	47
Field Artillery Automatic Data Computer (FADAC)		
Safety Limits by FADAC.....	Nov 61	67
FADAC has Successful Debut (newsnote)	Mar 61	72
FADAC Operational (newsnote).....	Nov 61	56
FADAC and Employment, in The Future of Cannon ..	Nov 61	16, 22
Field Artillery Industrial Conference		
Results of Field Artillery Industrial Conference (newsnote)	Mar 61	74
Field Artillery Tactical Operations Center (FATOC)		
Tactical Redstone Employment.....	Mar 61	44
Field Exercise Number 1		
The White Plan	Mar 61	12
Fire Control, Jungle		
Part 2 The Jungle—Special Warfare	Aug 61	26
Part 4 Fire Control—Special Warfare	Nov 61	9
Fire Direction		
Status of FDC Graphical Tools	Mar 61	47
Fire Planning		
Premeditated Destruction—Fire Planning	Jun 61	44
Fire Support Coordination Center		
Anytime to Anyplace and Fight— The Airborne Division	Mar 61	33
Fire Support Element		
Tactical Redstone Employment.....	Mar 61	44
Firing Tables		
Firing Tables 155-Q-3— Status of FDC Graphical Tools	Mar 61	47, 51
Firing Tables 8-J-3— Status of FDC Graphical Tools	Mar 61	47, 51

SUBJECT	ISSUE	PAGE
Firing Tables 105-H-6—		
Status of FDC Graphical Tools	Mar 61	47, 51
Firing Tables 762-F-1—		
Status of FDC Graphical Tools	Mar 61	47
Status of FDC Graphical Tools FT-8-O-3	Mar 61	50
New Firing Tables Format	Mar 61	51
Firing Tables 8-J-2	Mar 61	51
Firing Tables 280-B-1	Mar 61	51
Foreign Artillery Weapons		
British Field Artillery	Aug 61	8
Soviet Armor and Artillery.....	Nov 61	29
Fuzes and Fuze Setters		
Filler—Fuze M520 to Replace Fuze M500	Mar 61	69
Artillery Ammunition—Fuzes and Boosters.....	Jun 61	31
Geographic Coordinate Scale		
Improved Accuracy . . . Geographic Coordinate Scale	Aug 61	47
Graphical Equipment, 8-inch Howitzer		
Status of Graphical "Tools"	Mar 61	47
New Graphical Equipment . . . FT 8-0-3	Aug 61	31
Graphical Equipment, 155-mm Howitzer		
Status of Graphical "Tools".....	Mar 61	47
New 155-mm Equipment (newsnote)	Mar 61	72
Graphical Firing Table Fan		
Status of FDC Graphical Tools	Mar 61	50
Guerrilla		
Part I—The Guerrilla . . . Special Warfare	Aug 61	15
Part III—Support of the Guerrilla . . .		
Special Warfare	Nov 61	5
Gun, 5.5-inch		
The 5.5-inch Gun	Aug 61	10
Gun, 175-mm (SP) (M107)		
175-mm Completes Testing (newsnote).....	Aug 61	60
175-mm Gun, in The Future of Cannon.....	Nov 61	20-22
Height of Burst Calculator		
(filler).....	Aug 61	50
		(con't 54)
Helicopter, Iroquois HU-1		
Your Sunday Punch—The Armor Group.....	Jun 61	30
HEP-T, M327		
Point-Blank Defense—Direct Fire	Jun 61	21

SUBJECT	ISSUE	PAGE
Honest John Rocket		
British Field Artillery	Aug 61	11
Honest John Camouflage	Nov 61	59
Howitzer, 75-mm pack		
Out Pops the Weasel	Aug 61	51
Howitzer, 105-mm		
New SP, towed . . . Lightweight 105-mm Howitzer	Aug 61	3
The Italian 105-mm Howitzer	Aug 61	10
XM102, Towed 105-mm Howitzer, Lightweight, in The Future of Cannon	Nov 61	20
XM104, SP, 105-mm Howitzer, Lightweight, in The Future of Cannon	Nov 61	20-21
T195E1 Armored, SP, 105-mm Howitzer, in The Future of Cannon	Nov 61	21
XM104, SP, 105-mm Howitzer (newsnote)	Nov 61	57
T195E1 Armored, SP, 105-mm Howitzer (newsnote).....	Nov 61	59
Howitzer, 155-mm		
T196E1 Armored, SP, 155-mm Howitzer	Nov 61	21
T72E1 155-mm Illuminating Shell (newsnote)	Nov 61	55
T196E1 Armored, SP, 155-mm Howitzer (newsnote) .	Nov 61	59
M1A2 Auxiliary Propulsion System for 155-mm Howitzer (newsnote).....	Nov 61	60
Howitzer, 8-inch, SP, M110		
Redesignation to M110	Aug 61	60
Role of, in The Future of Cannon	Nov 61	20-22
IBM 709 (Computer)		
The White Plan	Mar 61	10
ICAO		
New Firing Tables Format	Mar 61	51
Metro Changes (filler)	Jun 61	7
Inspections		
Radio/Wire Display for CMI	Nov 61	3
Instruction		
Guerrilla, Jungle.....	Aug 61	30
Reorganization	Aug 61	30
Intelligence		
The Intelligence Chain— Strong as its Weakest Link	Mar 61	54
Jungle		
Part II—The Jungle . . . Special Warfare	Aug 61	22

SUBJECT	ISSUE	PAGE
K-Transfer		
Concept of Caliber Coordination— Cannon Correlation	Jun 61	8
Lacrosse Missile		
Second Lacrosse Firing Completed at Fort Sill (newsnote).....	Mar 61	74
Electronic Referee . . . Lacrosse TSS.....	Aug 61	36
Laying Artillery Weapons		
Point-Blank Defense—Direct Fire.....	Jun 61	17
Leading		
Point-Blank Defense—Direct Fire.....	Jun 61	18
Little John Rocket		
First Little John Battalion Activated (newsnote)	Mar 61	74
Maintenance		
Preventive Maintenance of Communications Equipment	Nov 61	41
Maps		
Transition to 1/50,000 Scale (filler).....	Mar 61	12
The "Art" of Warfare—Maps (filler)	Mar 61	35
March Column		
A Time-Interval Technique—March By The Clock.....	Jun 61	5
Mechanical Mule M274		
Anytime to Anyplace and Fight— The Airborne Division	Mar 61	30
Meteorology		
Metro Changes (filler)	Jun 61	7
Employment of Metro Sections	Nov 61	43
Meteorological Message		
Firing Data Weatherproofed—Metro Validity	Jun 61	41
Meter (Metric System)		
When is a Meter a Meter? (filler)	Mar 61	46
Mohawk		
Passes Rigorous Tests (newsnote).....	Aug 61	60
NATO Metro Message		
New Firing Tables Format	Mar 61	51
Metro Changes (filler)	Jun 61	7

SUBJECT	ISSUE	PAGE
Nuclear Weapons, Preparatory Subcourse		
Nuclear Weapons Preparatory Subcourse (filler and ad).....	Aug 61	2, 7
Observation		
The Intelligence Chain— Strong as its Weakest Link	Mar 61	54
The Orange Plan		
The White Plan	Mar 61	12
Pershing Missile		
Progress of (newsnote)	Nov 61	56
P (f) Computer		
New P (f) Computer (filler)	Jun 61	40
Radar Mechanic		
Checklist for the Radar Mechanic.....	Aug 61	55
Radar Set AN/MPQ-4		
The Intelligence Chain— Strong as its Weakest Link	Mar 61	65
Radar Set AN/TPS-25		
The Intelligence Chain— Strong as its Weakest Link	Mar 61	65
Radar Set, M33A1G		
Lacrosse TSS	Aug 61	36
Radio Controlled Aerial Target (RCAT)		
Artillery's Candid Camera—SD-1 Drone	Mar 61	5
Radio Mount, MT-299/GR		
Gem for the Communications Officer.....	Jun 61	13
Radio Sets		
AN/VRC-9, AN/VRC-10, AN/VRC-30. Anytime to Anyplace and Fight—The Airborne Division	Mar 61	32
AN/GRC-50, Newsnote	Nov 61	56
Radio Systems		
Display for Inspections	Nov 61	3
Radio Systems in the New Divisions.....	Nov 61	49-50
A Gem for the Radio Repairman	Nov 61	52
Red Plan		
The White Plan	Mar 61	12
Redstone Missile		
Tactical Redstone Employment.....	Mar 61	42

SUBJECT	ISSUE	PAGE
Reorganization		
Reorganization of the Army Divisions (Supplement to regular Aug issue).....	Aug 61	
Resident Courses		
Current Resident Course Schedule—Newsnote	Mar 61	79
Resident Courses—USAAMS	Jun 61	49
The Royal Artillery		
The Queen's Gunners.. . . British Field Artillery	Aug 61	8
S2		
The Intelligence Chain— Strong as its Weakest Link	Mar 61	54
S3		
The Intelligence Chain—Strong as its Weakest Link ..	Mar 61	56
Safety Officer		
Theory and Practice—Safety Officer Training	Jun 61	3
Safety Stops		
Safety "Stops" for Traverse and Elevation.....	Mar 61	70
Scale, Geographic Coordinate		
Geographic Coordinate Scale	Aug 61	47
Slide Rule		
New Slide Rule (newsnote)	Mar 61	73
Artillery Nonnuclear weapons effects slide rule (filler)	Nov 61	14
Soviet Union Artillery		
Soviet Armor and Artillery.....	Nov 61	29
Special Warfare		
The Guerrilla . . . Special Warfare	Aug 61	15
The Jungle . . . Special Warfare	Aug 61	22
Support of the Guerrilla . . . Special Warfare.....	Nov 61	5
Fire Control . . . Special Warfare	Nov 61	9
Strategic Army Corps—STRAC		
Anytime to Anyplace and Fight— The Airborne Division	Mar 61	13
Survey		
Sea-going Survey—Artillery's Helping Hand	Mar 61	36
Survey in the Jungle.....	Aug 61	27

SUBJECT	ISSUE	PAGE
Survey Instrument, Azimuth, Gyro, Artillery		
Pinpoint Accuracy Survey Instruments in Production (newsnote)	Mar 61	73
Survey Instrument Progress (newsnote)	Nov 61	60
T162		
The T162 Boresighting Device	Aug 61	44
Tabular Firing Tables		
Status of FDC Graphical Tools	Mar 61	47
Tactical Employment		
In the Jungle	Aug 61	28
Tank, M56		
Anytime to Anyplace and Fight— The Airborne Division	Mar 61	28
Tank, M60		
Your Sunday Punch—The Armor Group	Jun 61	26
Tank, M103		
Your Sunday Punch—The Armor Group	Jun 61	29
Tank, Specialized Equipment		
Your Sunday Punch—The Armor Group	Jun 61	29
Target Acquisition		
In the Jungle	Aug 61	25
Telescopes, Fire Control		
Point-Blank Defense—Direct Fire	Jun 61	21
Tellurometer		
Tellurometer Requires New System of Survey Tolerances	Mar 61	73
Survey Instrument Progress (newsnote)	Nov 61	60
Trainer, 14.5-mm		
14.5-mm Trainer Improvement	Aug 61	58
Training		
In the Jungle	Aug 61	29
Trajectory Safety System		
Lacrosse TSS	Aug 61	36
25-Pounder		
The 25-Pounder	Aug 61	11
US Coast and Geodetic Survey		
Sea-going Survey—Artillery's Helping Hand	Mar 61	36

SUBJECT	ISSUE	PAGE
Visibility Diagrams		
The Intelligence Chain— Strong as its Weakest Link	Mar 61	59
Weapons System		
Specialization and Teamwork— The Weapons System	Jun 61	47
The White Plan		
The White Plan	Mar 61	10
Wire Systems		
Display for CMI.....	Nov 61	3
Wire Systems in the New Divisions.....	Nov 61	51
A Gem for Wiremen.....	Nov 61	52
XM53 Sight Unit		
XM53 Sight Unit to be Tested	Mar 61	80
XM102, XM103, XM104		
New SP, Towed . . . Lightweight 105-mm Howitzer ...	Aug 61	4, 5

●

OPERATION TAPER

The US Continental Army Command has just approved a new system of equipment records. The new system, entitled The Army's Plan for Equipment Records Revision (TAPER), will be fully implemented in the Army by the end of 1962. The revised equipment record system will be used in managing the maintenance of *all* equipment and will not be confined to use with tank and automotive equipment. TAPER is a giant step toward providing the commander and supervisor with better management tools. These tools will ultimately result in reduction of personnel, time, and materiel. In keeping with the policy of publishing the newest techniques for the benefit of artillerymen, ARTILLERY TRENDS will have a comprehensive article on Operation TAPER in its next issue.

●

The artilleryman has a profession that requires and repays close study; one does not acquire knowledge of it casually . . . Write for your Artillery Extension Course(s) today, right now . . . don't let tomorrow become yesterday before you do it.

●

In 1864 the Swiss introduced the system of measuring all artillery angles in "mils" . . . though 100 years old, this system still proves itself in its original form . . . our future artillery will certainly continue to utilize this time honored mathematical measuring method.