



DB Manual

EXTRACT!

# Work procedures for permanent way maintenance

7th revised and  
extended edition

Lothar Marx

Dietmar Moßmann

### **German National Library bibliographic information**

The German National Library catalogues this publication in the German National Bibliography; detailed bibliographic information can be found in the Internet under <http://dnb.d-nb.de>.

Lothar Marx • Dietmar Moßmann

Translation: beo Gesellschaft für Sprachen und Technologie mbH/Ian W. Rhodes ([www.beo-doc.de](http://www.beo-doc.de))

### **Work procedures for permanent way maintenance**

DB manual

7<sup>th</sup> revised and extended edition – Bahn Fachverlag GmbH, Berlin 2013

Work on this volume for the German version was completed in November 2011

Publisher:

Bahn Fachverlag GmbH in co-operation with DB Training, Learning & Consulting

© Bahn Fachverlag GmbH, Berlin 2013

All rights, including translation into foreign languages, are reserved by the publisher. No part of this work may be reproduced, processed, copied or distributed in any form (photocopy, microfilm or any other procedures), including for training purposes, using electronic systems without the written approval of the publisher.

The names of products mentioned in the book which are simultaneously registered trademarks have not been specifically identified. The absence of the ® symbol does not therefore infer that the name is a free product name. Nor is any reference made to the existence of patents or utility model protection.

Title photo: SWIETELSKY Baugesellschaft m.b.H.

Illustrations without source information: L. Marx/D. Moßmann

Cover design and layout: DB AG; CRUFF, Berlin

Printing and binding: Laub GmbH & Co. KG, Elztal-Dallau

Printed in Germany

ISBN: 978-3-943214-03-1

# Preface

The number of editions of the “Work procedures for permanent way maintenance” manual which have been published so far indicates the dynamic and extensive developments in railway permanent way maintenance procedures since the first edition of the book 25 years ago.

This 7th edition is a snapshot of the current track and switch inspection, maintenance and repair technologies. The detailed descriptions of work procedures in interaction with personnel, machines and equipment lend this DB manual the status of a reference work for students, newcomers to the profession, specialist tutors and trainers.

The topics surrounding permanent way maintenance are rounded off by an insight into new technologies. The compatibility of new work procedures, further developed components or modified machines and equipment with the increasing scheduling and financial dependencies in permanent way maintenance will have to be verified in operational trials.

DB Netz AG is extensively interested in the further development of maintenance procedures. Due to the increasing requirements being made on the availability of the permanent way, the railway infrastructure urgently requires diverse work procedures to economically maintain its facilities. In this regard, DB Netz AG is one of the track construction industry’s most important partners.

I would like to cordially thank the two authors and former employees, Mr. Lothar Marx and Mr. Dietmar Moßmann, for their work. They have again vigorously taken up an elementary railway topic in order to practically address the requisite knowledge and information.

I sincerely hope that this manual’s readers are able to find answers to their questions, and to extend and pass on their knowledge. Let us hope that this leads to stimuli for further developments in permanent way maintenance.



Oliver Kraft, CEO of DB Netz AG

## Preliminary remarks

The maintenance of tracks and switches to guarantee operational safety necessitates knowledge of the work procedures, the relevant working methods and the individual track machinery and equipment. The authors' task was therefore to clearly and understandably convey the process technology applied at DB Netz AG to all interested parties.

This new edition of the manual is intended to be used as a training and advanced training document and to provide knowledge regarding the interaction of personnel, machines and track equipment in permanent way maintenance.

Changes have particularly arisen due to the inclusion of:

- track renewal train RU 800 S,
- track renewal train SUM 315,
- the P 95-SR track renewal trains,
- track renewal train P 100,
- ballast cleaning machines RM 95-700 and RM 95-800 W,
- the new tamping machines for tracks (09-4X) and switches 09-475 Unimat 4S,
- the survey procedures EM-SAT, GEDO and GRP,
- the switch transport wagon WTW,
- the new formation rehabilitation machine PM 1000,
- rail milling machine SF 03,
- track renewal train SUZW 500.

New chapters dealing with the following topics have also been added:

- Track equipment,
- Substructure,
- Line layout and routing,
- Ballast bonding,
- Noise insulation.

The installation and maintenance of the ballastless track system are additionally described. The ballastless track systems have also been further developed, particularly the RHEDA, Züblin, Bögl and Infundo design types.

The technical status of the work procedures is documented up to September 2010.

At this point, we would like to thank all of our expert colleagues for their friendly assistance and helpful advice. We would also like to thank the track maintenance companies and the manufacturers of the machines, equipment and materials required for maintenance for their valuable support and for providing us with documents which contributed towards making this manual a success. We would particularly like to thank Messrs. Armbruster, Dietrich, Dr. Hetzel, Knöfel, Dr. Kratochwille, LeDosquet, Rausch and Zück of DB for their kind co-operation. Additional thanks go to Mr. J. Rauch (IBES Baugrundinstitut GmbH) and Dr. Stefan Lutzenberger (Müller-BBM GmbH) for their supporting preliminary work.

Mainz, September 2010

The authors

# 1 General

The task of permanent way maintenance is to provide the user (passenger and goods transport) with an infrastructure which meets the requirements in terms of speed, load and safety according to technical and economic aspects. The DB Netz AG infrastructure encompasses around 64,000 km of track and around 67,000 switch units (Fig. 1-1).

EXTRACT!

## "Network 21" in 2012

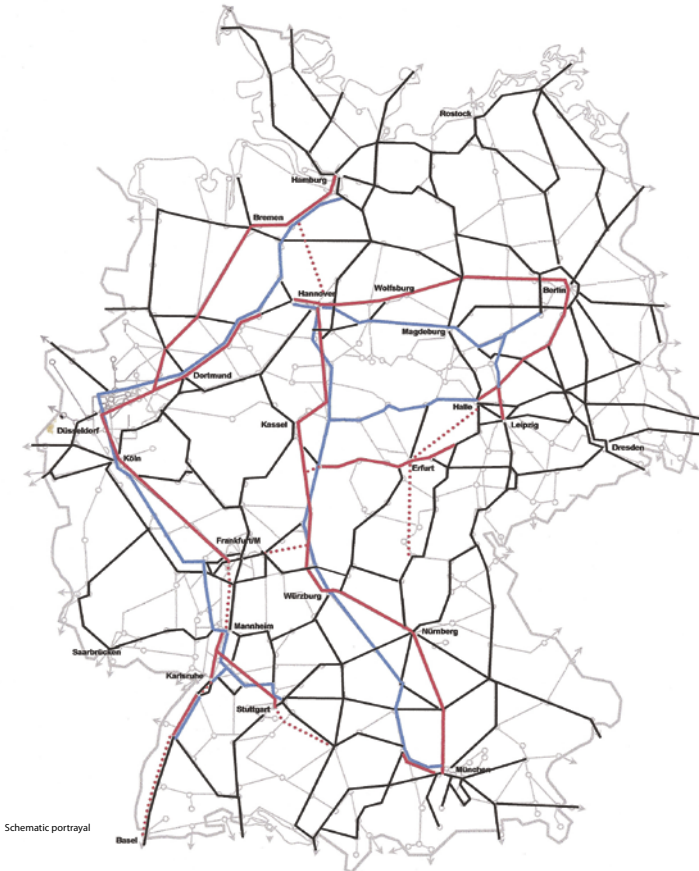

### Priority network

Demixing of faster and slower traffic in economic corridors

### High-performance network

Significant additional routes outside of the priority network

- Routes for high-speed trains
- Routes for lower-speed trains
- Routes in the high-performance network
- ⋯ Corridors still without financing decision or in planning or under construction

Fig. 1-1: DB Netz AG railway network showing the priority and high-performance network

Graphic: DB AG/Le Dosquet

Commissioning of the routes:

- Mannheim – Stuttgart in 1991,
- Hanover – Würzburg in 1991,
- Hanover – Berlin in 1998,
- Cologne – Frankfurt in 2002 and
- Nuremberg – Erfurt in 2006

represented milestones in the high-speed network ( $v > 160$  km/h), which now covers a track length of around 5,000 km, whereby the permissible speed on the new lines is 300 km/h with the ICE 3 (Fig. 1-2).



Fig. 1-2: ICE 3 on the new Cologne – Frankfurt (M) line

It has also been possible to increase the speed throughout the existing network, whilst retaining the route parameters, thanks to higher-performance vehicles in passenger and goods transport (Figs. 1-3 and 1-4).



Fig. 1-3: ICE T with body-tilting technology



Fig. 1-4: High-speed goods transport at 120 km/h

In addition to the classic superstructure components (rail, sleeper and ballast), the installation of ballastless track system constructions (see Chapter 14.3) will also be described. Maintenance costs are to be reduced even further through innovative track constructions.

Each year, DB Netz AG spends considerable amounts of money on track maintenance and renewal. Performance of this work – often under difficult operational conditions –

necessitates a high number of well-trained skilled civil engineering workers/track layers (internal employees and staff from track maintenance companies).

These employees are supported by track renewal trains (RU 800 S, SUM Q, UM 1 to 3, UM-S, SUM, SMD – 80, SUZ 500 UVR) and portal cranes (e.g. UN, Donelli), renewal machine units for switches and tracks, 15 t to 150 t cranes plus WM 500 U, ballast cleaning machines for tracks and switches as well as tamping machines for tracks and switches. Small machines and items of equipment are additionally available.

To organise this work, work specifications are drawn up for the deployment of track maintenance companies.



## 2 Track equipment

### 2.1 General

The permanent way, consisting of the track and switch constructions including crossings and rail expansion joints, is generally the most highly-stressed part of the infrastructure. Since railways came into being, the ballast superstructure and its components, the rail, rail fastening, sleeper and ballast, have undergone significant technical development, up to and including the currently familiar forms of the cross sleeper track and the ballastless track system design types. The superstructure products, design types or construction procedures may only be used if they have been certified by the Federal Railway Office and/or approved by DB Netz AG's headquarters.

This chapter will only deal with the currently conventional superstructure components.

### 2.2 The rails

Today, form 60 E2, 54 E4 and 49 E5 rails are generally used by Deutsche Bahn (Fig. 2-1). The rails are usually supplied in what is referred to as their naturally hard condition (pearlitic rails). As a rule, the rails used by Deutsche Bahn have a minimum strength of 700 N/mm<sup>2</sup>, whilst wear-resistant rails have a minimum strength of 900 N/mm<sup>2</sup> (the tensile strength of the rail steel is used as rail strength  $\sigma_{fracture}$  [N/mm<sup>2</sup>]). To achieve higher rail strengths, pearlitic, naturally hard rails are additionally heat treated (e.g. head-hardened rails).

The rail's identification includes the following data such as manufacturer, year of rolling, profile and steel grade.

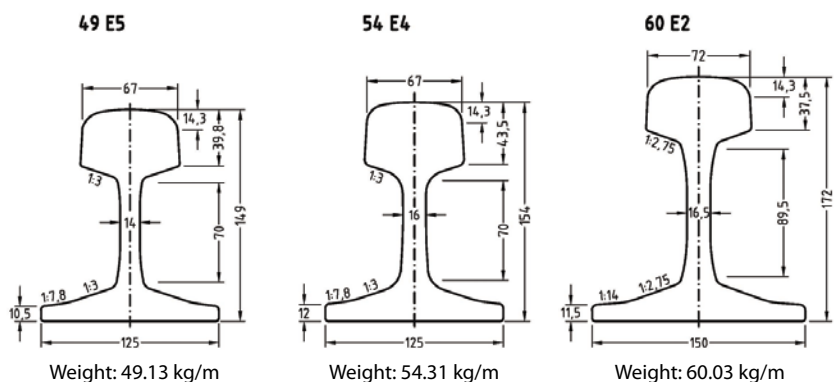

Fig. 2-1: Rail forms with their most important dimensions

Graphic: DB AG/Stefan Balfanz

Today, a continuous welded rail track is usually produced. The rails are prefabricated in the factory and delivered to the installation location in lengths up to 120 m. Thanks to the lower number of welds, higher productivity during neutralisation, clamping and welding is

achieved on the worksite. Joint gap rails are manufactured from rails with standard lengths of 30 m, 45 m or 60 m.

Profile transition rails are installed in tracks with different rail base widths and/or rails with height differences of >5 mm. For example, form 54 E4 rails must be fitted between form 60 E2 and form 49 E5 rails. Profile transition rails are usually prefabricated in the welding factory.

Rails have to meet requirements including the following:

- High resistance to wear,
- High fatigue strength,
- High yield strength, tensile strength and hardness,
- Good welding suitability,
- High degree of purity,
- Good surface quality and
- Low internal stresses following production.

### **2.2.1 Insulated rails**

Insulated rails are as long as the largest wheel-base which occurs (30 m) and are insulated from the opposite rail. To achieve this, both ends of the insulated rail are joined to the neighbouring rails by means of an insulated joint.

### **2.2.2 Insulated joints**

Due to safety reasons, insulated joints which prevent the passage of electrical current have to be installed in the track.

The production of insulated joints in the track has not proved worthwhile, and is therefore usually carried out in the factory. To do this, 3 to 5 m long rail sections are bonded using adapted fish plates and tensioned with high-strength bolts. A distinction is made between design type S and IVB 30° insulated joints manufactured in the factory and design type MT insulated joints produced in the track. Design type IVB 30° insulated joints currently have to be used as standard in tracks and switches. Design type MT insulated joints are only permissible if design type IVB 30° insulated joints manufactured in the factory cannot be used (e.g. structural joints of switches and crossings).

The finished insulated joints are welded into the track at the work site (see Figures 2-2 to 2-5).

### Insulated joint design type S

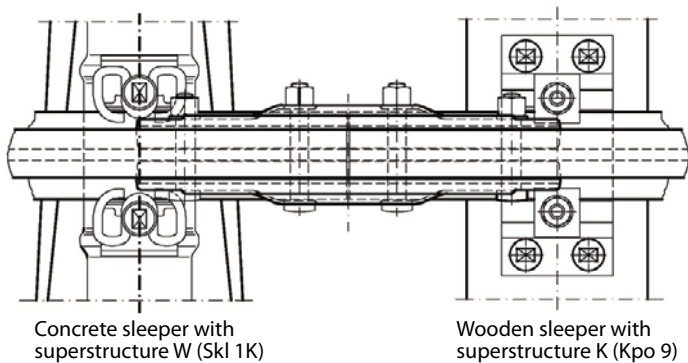

Fig. 2-2: Insulated joint design type S

Graphic: DB AG/Stefan Balfanz

### Layout of "IVB 30°" in the track

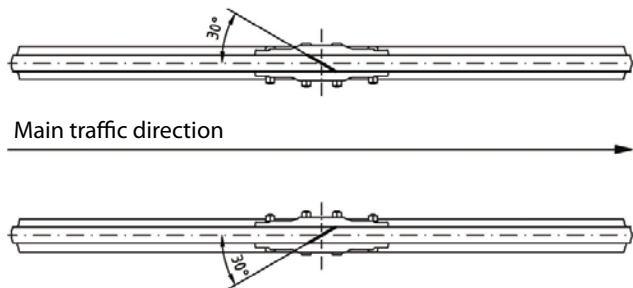

Fig. 2-3: Insulated joint IVB 30° (main traffic direction)

Graphic: DB AG/Stefan Balfanz

### Sketch of insulated joint design type "IVB 30°" system

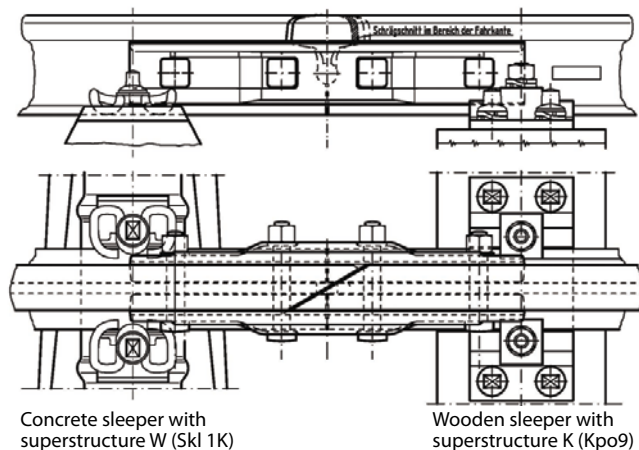

Fig. 2-4: Insulated joint IVB 30° (detail)

Graphic: DB AG/Stefan Balfanz



Fig. 2-5: Insulated joint IVB 30° (original)  
Photo: DB AG/Stefan Ballfanz

## 2.3 The sleepers

Wood, concrete or steel can be used as construction materials for sleepers. The sleepers' tasks include:

- Establishing and maintaining the track gauge,
- Distributing and conducting forces on the ballast,
- Locating the rails,
- Securing the position of the track,
- Damping rail vibrations,
- Reducing the influences of sound waves and body-borne sound waves on the environment.

### 2.3.1 The wooden sleepers

Wooden sleepers are produced using oak, red beech, pine or larch, among other woods. The standard types of wood currently used in Europe are beech for dancing sleepers and oak for crossing timbers. All wooden sleepers are impregnated to protect them from rotting. The service life of an impregnated wooden sleeper is 30 to 45 years. They are unsuitable for high-speed lines with speeds in excess of 160 km/h, as they exhibit 15 percent lower lateral displacement resistance.

### 2.3.2 The steel sleepers

The steel sleepers are manufactured in trough form (Fig. 2-6). The material which is used is steel S235JR. They have a service life of between 40 and 60 years.

Advantages:

- Low weight, so easier to handle,
- Low installed height, so less ballast required,
- Long service life.

Disadvantages:

- Lateral displacement resistance is lower in comparison with concrete sleepers,
- More complex track insulation,
- Increased ballast wear.

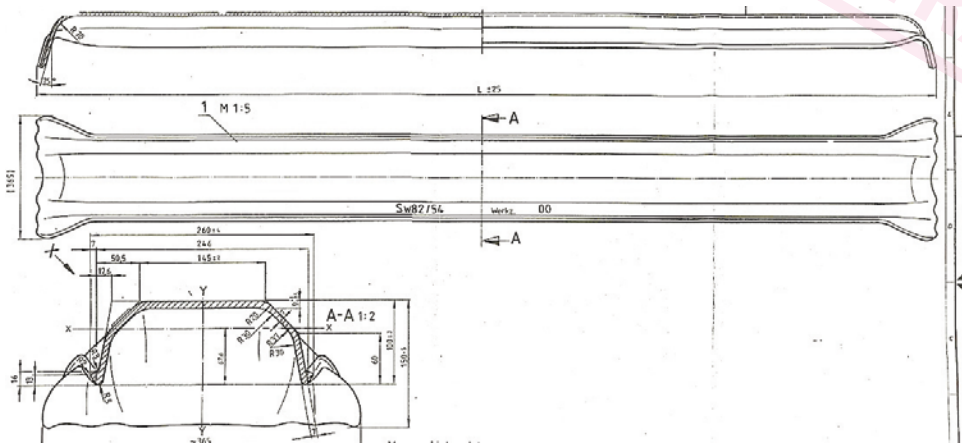

Fig. 2-6: Steel sleeper ST 82

Graphic: DB AG

### 2.3.2.1 Y-steel sleeper St 98

The Y-steel sleepers consist of two hot-rolled IB 100S broad-flanged girders bent in an s shape and two straight girder sections with the same profiles. The steel profiles are joined at each end of the sleeper by means of two upper and two lower locks, which are welded to the girder flanges (Fig. 2-7). The insulated support point S15 with tension clamp S14 is used as the rail fastening.

The Y-steel sleepers are used in both the ballast superstructure and the ballastless track system in combination with an asphalt base layer (also see Chapter 14.3 “Ballastless track system”). In contrast to the “standard” steel sleeper, the Y-steel sleeper exhibits high lateral and longitudinal displacement resistance. Its disadvantages include more complex maintenance and tamping with switch tamping machines. Installation of the Y-steel sleeper is carried out according to guideline 824.2060 and can be accomplished using all conventional procedures (e.g. with UM1, SUZ 500). The Y-steel sleeper is not installed on earth-work foundations in high-speed lines.

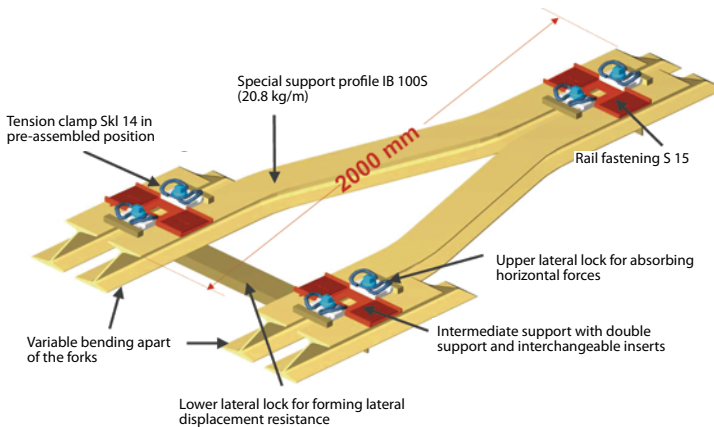

Fig. 2-7: Y-steel sleeper

Graphic: ThyssenKrupp GfT Gleistechnik GmbH

### 2.3.3 The reinforced concrete sleeper

Today, reinforced concrete sleepers are the standard design type for standard-gauge railway tracks (Figs. 2-8, 2-9 and 2-10). The prestressed concrete sleepers most commonly used by Deutsche Bahn are the B 70 W-60, B 70 W-54, B70 W-24 and B 90 W-60/54. The significant advantages of reinforced concrete sleepers include their extensive prevention of track buckling caused by high weight, good gauge maintenance and long service life.

Each concrete sleeper must show the following identification:

- Year of manufacture,
- Rail base width,
- Design series symbol,
- Formwork number,
- Factory symbol.

In addition to the static test, the dynamic bending test in which shock load in the track is simulated also has to be performed as part of the certification test for concrete sleepers. The fatigue test also forms part of the certification test, as does the measurement of electrical sleeper resistance (minimum ballast resistance = 3 ohm/km).

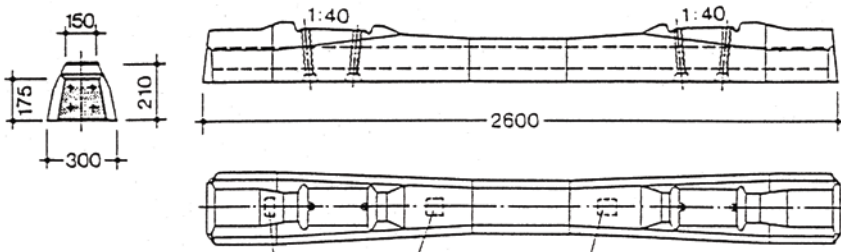

Fig. 2-8: Prestressed concrete sleeper B 70 W-(60 and 54)

Graphic: DB AG

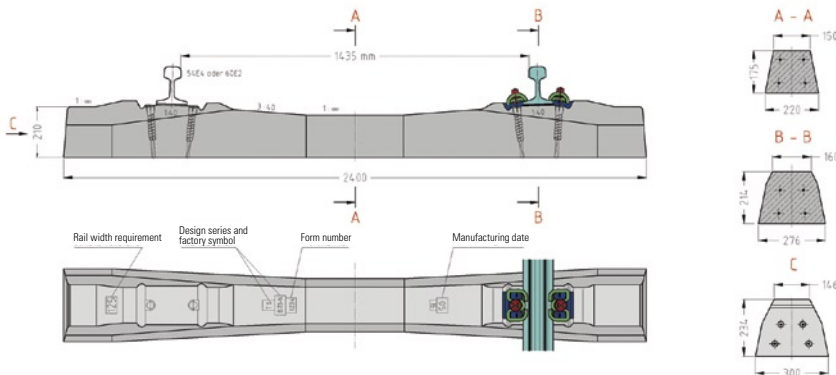

Fig. 2-9: Prestressed concrete sleeper B 70 W 24

Graphic: DB AG/Stefan Balfanz

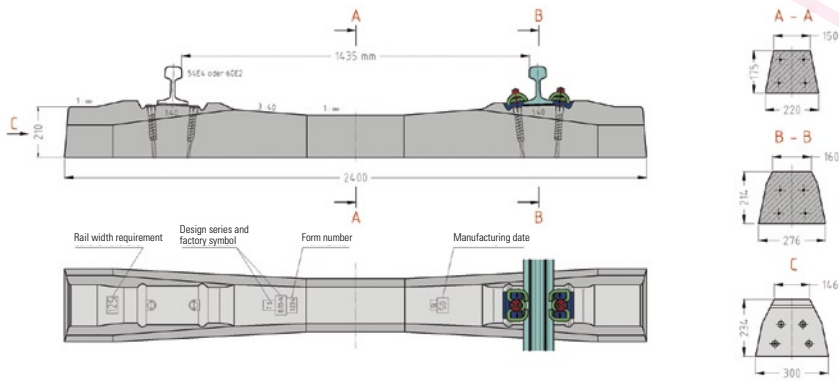

Fig. 2-10: Design of dancing sleeper B 90

Graphic: DB AG/Stefan Balfanz

## 2.3.4 Special forms of concrete sleeper

### 2.3.4.1 The twin sleeper

The conceptual design of the twin sleeper is based on the features of the B-70 sleeper. The sleeper width (57 cm) is doubled and its length is shortened by 20 cm. The sleeper height, fastening and support points are identical. Water channels are located on the outer side. These channels are raised in the centre so that the water is able to drain off outwards. The 3 cm laying gap between the sleepers is sealed using a soft PVC cover. This prevents the ingress of dirty water and surface water (Fig. 2-11).

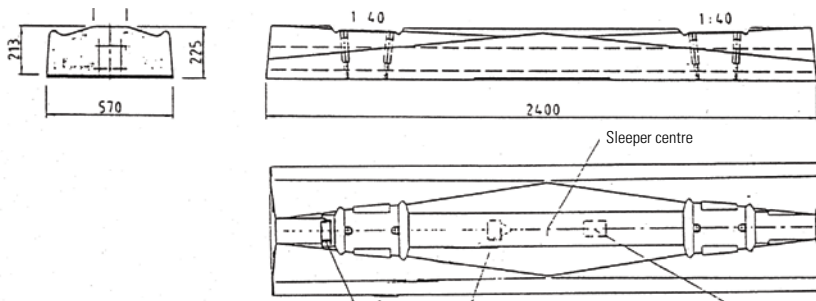

Fig. 2-11: Prestressed concrete twin sleeper BBS 1 W - (60 and 54)

Graphic: DB AG

### 2.3.4.2 The padded sleeper

In this system, the concrete sleepers are “padded” with an elastic material on the underside of the sleeper. Sylomer and Sylodyn have proved to be suitable materials for this (also see Chapter 14.9 “Installation of special sleepers”). As part of track or sleeper renewal or new track construction, sleepers with elastic bases or sub-ballast mats have to be installed in the area of man-made structures (e.g. bridges, tunnels, trough structures, passages) in order to reduce ballast stress.

Padded concrete sleepers offer advantages including the following:

- Reduction of hard contact between the sleeper sole and ballast,
- Reduction of ballast compaction,
- The superstructure becomes more elastic,
- Lines with padded sleepers exhibit very high dimensional stability with little settling,
- Reduction of body-borne sound transmission,
- Reduction of slip wave formation in radii with  $r < 500$  m.

The requirements on sub-ballast mats and sleepers with elastic soles are regulated in DB standards DBS 918 071, DBS 918 145-1 and DBS 918 145-2 (technical terms of delivery).

## 2.4 The sleepers of the ballastless track system

The sleepers for constructing the ballastless track system have been developed on the basis of the classic ballast superstructure (cross sleeper superstructure). This is the simplest method for ensuring the required track geometry (including the track gauge) in the ballastless track system. In this case, the sleepers may be concreted into the slab in combination with the rails (track panel) or individually.

Different sleepers such as prestressed concrete sleepers, conventionally reinforced concrete sleepers as twin-block concrete sleepers or steel sleepers are used for the diverse ballastless track system design types. The most common concrete sleepers currently used by Deutsche Bahn for certain ballastless track system design types are shown in the following (Figs. 2-12 to 2-18):

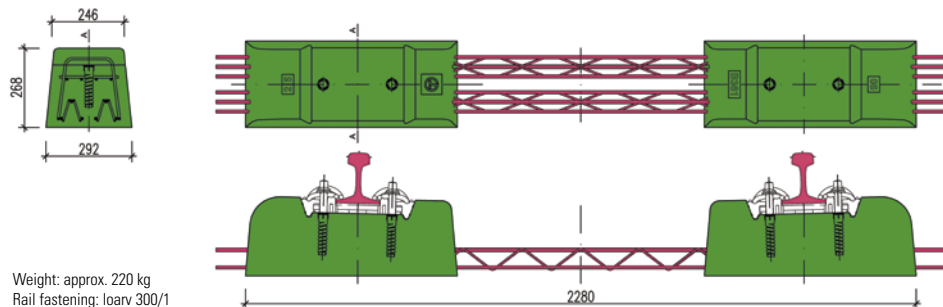

Fig. 2-12: Züblin design type, concrete sleeper B 305 W-60

Graphic: Ed. Züblin AG



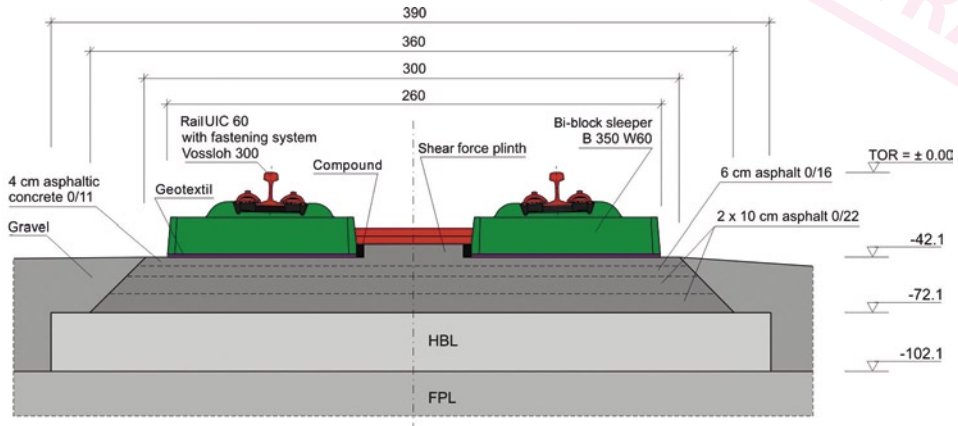

Fig. 2-13: ATD design type with twin-block concrete sleeper B 350 W-60

Graphic: Rail.One GmbH

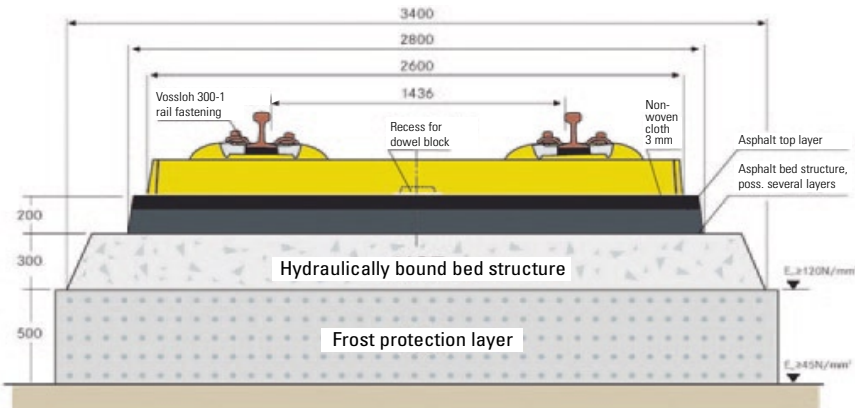

Fig. 2-14: Getrac design type with monobloc concrete sleeper B 316 W-60

Graphic: Rail.One GmbH

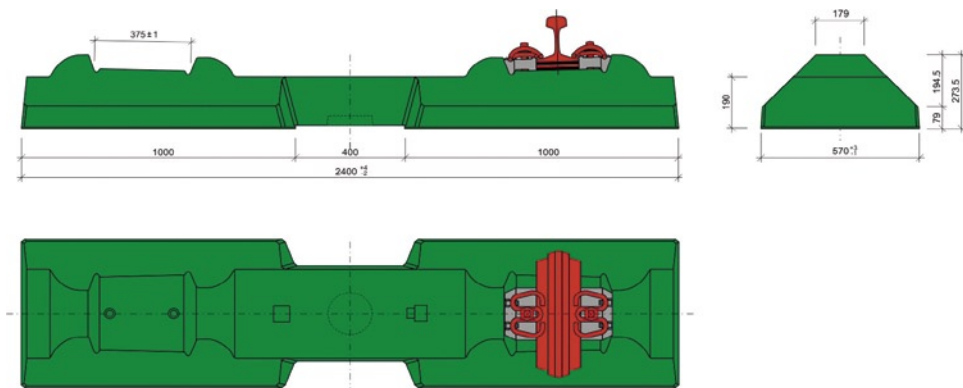

Fig. 2-15: Twin concrete sleeper BBS 3 W-60, Getrac design type

Graphic: Rail.One GmbH

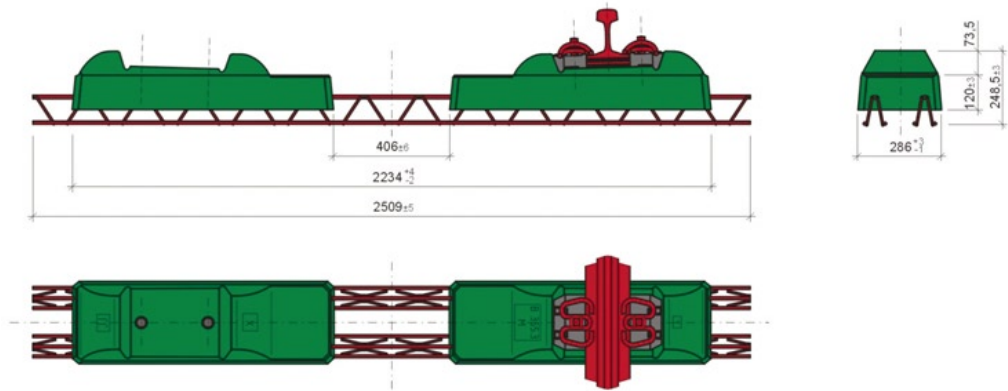

Fig. 2-16: Twin-block concrete sleeper B 355.3 W60M for RHEDA 2000 design type

Graphic: Rail.One GmbH

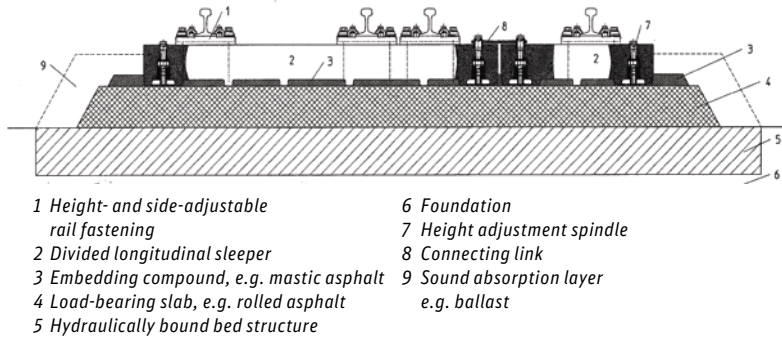

Fig. 2-17: Concrete switch sleeper on asphalt bed structure

Graphic: DB AG

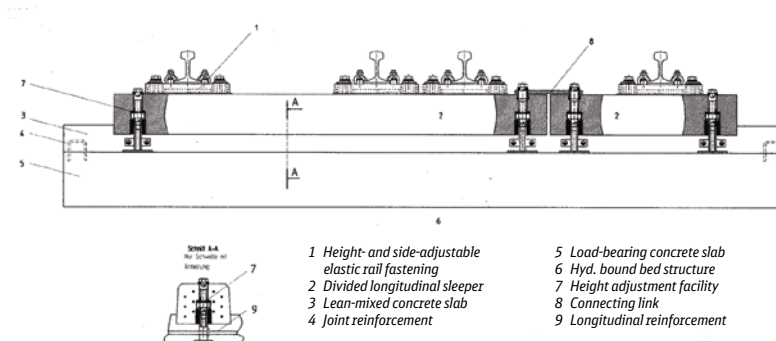

Fig. 2-18: Switch sleeper on concrete bed structure

Graphic: DB AG

EXTRACT!

This DB manual provides specialists and managers who plan and execute work on the permanent way with knowledge concerning the interaction of personnel, machines, devices and track equipment during permanent way maintenance. The authors clearly describe the work procedures involved in the repair and installation of tracks and switches, including ballast cleaning and mechanical tamping work. Both formation rehabilitation methods and day-to-day maintenance are dealt with.

The reader is familiarised with inspection and maintenance work as well as the acceptance of permanent way services. The authors also deal with the relatively new topic of „ballastless permanent way systems“ (ballastless track system) and provide an outlook concerning further developments in track maintenance machines and working procedures.

---

**Bahn Fachverlag**

**[www.bahn-fachverlag.de](http://www.bahn-fachverlag.de)**

**ISBN: 978-3-943214-03-1**