



**Schriftenreihe der
Bundesanstalt für
Arbeitsschutz und
Arbeitsmedizin**

Forschung

Fb 851

W. Probst

Checking of Sound Emission Values

Arbeitsschutz

W. Probst

Checking of Sound Emission Values

Verfasser: Dr. rer. nat. Wolfgang Probst

ACCON GmbH
Ingenieurbüro für Schall- und Schwingungstechnik
Gräfelfinger Str. 133 A, D-81375 München

Verlag/Druck: Wirtschaftsverlag NW
Verlag für neue Wissenschaft GmbH
Bürgermeister-Smidt-Str. 74 - 76, D-27568 Bremerhaven
Postfach 10 11 10, D-27511 Bremerhaven
Telefon: (04 71) 9 45 44 - 0
Telefax: (04 71) 9 45 44 - 77

Herausgeber: Bundesanstalt für Arbeitsschutz und Arbeitsmedizin
Hauptsitz Dortmund:
Friedrich-Henkel-Weg 1 - 25, D-44149 Dortmund
Postfach 17 02 02, D-44061 Dortmund
Telefon: (02 31) 90 71 - 0
Telefax: (02 31) 90 71 - 454

Sitz Berlin:
Fachbereich Arbeitsmedizin
Nöldnerstr. 40 - 42, D-10317 Berlin
Postfach 5, D-10266 Berlin
Telefon: (0 30) 5 15 48 - 0
Telefax: (0 30) 5 15 48 - 170

Alle Rechte einschließlich der fotomechanischen Wiedergabe und des auszugsweisen Nachdrucks vorbehalten.
Aus Gründen des Umweltschutzes wurde diese Schrift auf chlorfrei gebleichtem Papier gedruckt.

ISSN 1433-2086
ISBN 3-89701-375-4

Index

Abstract	6
Kurzreferat	7
Résumé	8
1 Introduction	9
2 Sound power level L_{WA} and emission sound pressure level L_{pA}	11
2.1 What does the sound power level state - definition and application	11
2.2 What does the emission sound pressure level state - Defintion and application	14
2.3 How does the noise immission at working places result from the noise emission values L_{WA} and L_{pA}	15
3 Standards for measurement of noise emission values	17
3.1 Standards for the measurement of the sound power level	17
3.2 Standards for the measurement of the emission sound pressure level	20
3.3 Remarks for a proper choice of the measuring method	22
4 Approximate methods for the measurement of emission values	23
4.1 Measurement on partial surfaces with different density of measuring points ...	23
4.2 Use of symmetry relations	24
4.2.1 Determination of the environmental correction K_2 with the reference sound source on a smaller measuring surface	24
4.2.2 Measurement on partial measuring surfaces	25
4.2.3 Measurement on short distance surfaces	26
4.2.4 Measurement in openings	26
5 Systematical deviations dependent on the measurement method and their correction	28
5.1 The true value of the sound power level	28
5.2 The angle error when measuring the sound power level according to the sound pressure envelopping surface method	30
5.2.1 The reason of an angle error	30

5.2.2	The smallest possible angle error in a box shaped measuring surface	31
5.2.3	The angle error with reference sound source or machine using a box-shaped measuring surface	34
5.3	The total correction of the angle error and the influence of the environment ...	40
5.4	Summary - proposal for a standardized total correction	42
6	Examinations regarding the accuracy of the standard series ISO 11200 for the determination of the emission sound pressure level.....	44
6.1	Scope	44
6.2	Description of the procedure.....	45
6.3	The vehicle as model machine	46
6.3.1	The measurement setup	46
6.3.2	The emission measured with free field conditions as reference.....	49
6.4	The measurements in halls.....	51
6.4.1	The acoustical properties of the halls.....	51
6.5	Measurements with the Model-machine and Determination of the Sound Power Level	54
6.6	Examination of errors when using K3-corrections according to ISO 11200 series.....	55
6.6.1	Statistical Approach	55
6.6.2	The correction according to the ISO 11200 series.....	56
6.7	Summary - results of the analysis.....	59
6.8	Measurement of the sound intensity level in three axes (ISO 11205 - 1997) ...	62
7	Examination regarding the accuracy of the standard draft ISO 3747 for the determination of the sound power level.....	70
7.1	Scope	70
7.2	Description of the procedure.....	71
7.3	The vehicle as model machine	72
7.3.1	The measurement setup	72
7.3.2	The emission measured with free field conditions as reference.....	72
7.4	The measurements in halls.....	74
7.4.1	The acoustical properties of the halls.....	74
7.4.2	Measurements with the model machine and determination of the sound power level.....	77
7.5	Evaluation and results	80

7.5.1 The method of evaluation	80
7.5.2 Results of the examination - evaluation for single points	84
7.5.3 Results of the evaluation for domains	91
7.5.4 Results of the evaluation with the statistical method.....	93
7.5.5 Results of the examination - number of RSS positlons	94
7.5.6 Results of the examination - rotating microphone.....	95
7.6 The use of indicators	96
7.7 Summary - recommendations for the use of ISO 3747	97
7.8 Proposal for an improvement of ISO 3747 -	
The selection of RSS and microphone positions	99
7.8.1 Determination of the minimum distance with $DL_r > 7$ dB.....	99
7.8.2 Determination of main radiating areas and their extension.....	99
7.8.3 Determination of RSS positions	100
7.8.4 Determination of microphone positions.....	101
8 Literature	102

Checking of Sound Emission Values

Abstract

With the machine directive the supplier must give appropriate information about the noise emission of his products. The main topics of the standards are explained.

Often it is not possible to use these standards in a strong sense and approximative methods have to be applied. Especially the measurement with very little microphone distance or even the measurement directly in radiating openings have proved to be effective, because environmental influences and noise impact from other machines is minimized in this case.

A consequence of the measurement with the soundpressure envelopping surface method is the angle error, that is determined with simulating calculations and presented as a function of the geometric parameters.

With an examination of the ISO 11200 series the accuracy of these standards was determined by using a van with calibrated broad band source as model machine. From the sound pressure levels measured at 94 points on an envelopping surface in freefield and in several industrial halls the emission soundpressure level and the resulting deviations are determined when using one of these standards. Those deviations are lowest when using ISO 11204 and ISO 11205.

A similar examination with ISO 3747 when measuring sound power levels shows, that the positioning the microphones in regions with $DLf > 7$ dB is sufficient and that the use of further indicators don't give better results. A procedure for the positioning of reference sound source and microphones is proposed.

Key words:

Sound power level, emission sound pressure level, angle error, ISO 11200 serie, ISO 3747.

Überprüfung von Geräuschemissionswerten Kurzfederat

Die Maschinenrichtlinie verlangt vom Hersteller, daß er die Geräuschkennwerte seiner Produkte als Information für den Anwender zur Verfügung stellt. Die dabei anzuwendenden Normen werden kurz erläutert.

Oft ist es nicht möglich, die genormten Verfahren streng anzuwenden, und es müssen Näherungsverfahren zugrundegelegt werden. Insbesondere die Messung in sehr kleinen Abständen und in den tatsächlich abstrahlenden Öffnungsflächen hat sich als sehr effektiv erwiesen, weil auf diese Weise der Raumeinfluß und auch der Fremdlärm von anderen, nicht abschaltbaren Maschinen minimiert wird.

Aufgrund des Winkelfehlers beim Schalldruck-Hüllflächenverfahren ergeben sich systematische Abweichungen, die mit Simulationsberechnungen in Abhängigkeit von den geometrischen Parametern ermittelt und dargestellt werden.

Mit einem Krafffahrzeug als Modellmaschine wird die Genauigkeit der Normen der Reihe ISO 11200 untersucht. Im Freifeld und in mehreren Industriehallen wurde der Schalldruckpegel auf 94 Punkten einer Quadermeßfläche ermittelt. Mit den Normen der ISO 11200 Reihe wird für jeden dieser Punkte der Emissions-Schalldruckpegel und dessen Abweichung vom wahren Wert bestimmt. Dabei zeigt sich, daß mit ISO 11205 bei Anwendung der 3-Achs-Intensitätsmessung und mit ISO 11204 die genauesten Ergebnisse erzielbar sind.

Eine ähnliche Untersuchung mit Anwendung der ISO 3747 zeigt, daß das Kriterium eines Meßpunktabstands mit einer Pegelüberhöhung D_{Lf} von 7 dB ausreichend ist und daß die Einbeziehung von anderen vorgeschlagenen Schallfeldindikatoren keine Verbesserung bringt. Ein Konzept zur Anordnung von Vergleichsschallquellen- und Mikrofonpositionen wird vorgeschlagen.

Schlagwörter:

Schalleistungspegel, Emissions-Schalldruckpegel, Winkelfehler, ISO 11200 - Reihe, ISO 3747.

Contrôle des valeurs d'émission sonore

Résumé

La directive sur les machines exige du fabricant qu'il informe l'utilisateur des caractéristiques sonores de ses produits. Les normes appliquées pour ce cas sont expliquées succinctement.

Souvent, il n'est pas possible d'appliquer strictement les procédés décrits dans la norme. Dans ces cas, il peut s'avérer opportun de se baser sur des procédés d'approximation. En particulier, le mesurage à de très petites distances et dans les surfaces réellement réfléchissantes s'est révélé très efficace parce que de cette manière l'influence environnementale ainsi que le bruit étranger d'autres machines ne pouvant pas être arrêtées ne jouent plus aucun rôle.

Un problème dans la palette de différents procédés normalisés offerte pour le mesurage du niveau de puissance sonore consiste dans le fait que ceux-ci offrent en partie des résultats systématiquement différents. En résultat de cette partie de l'étude, un concept est présenté qui permet d'intégrer toutes les normes concernant la détermination de la puissance sonore dans un système global sans déviations systématiques.

La précision des normes de la série ISO 11200 est étudiée avec un véhicule servant de machine-modèle. Le véhicule est doté d'une source de bruit et en ouvrant ou fermant une fenêtre, les deux conditions, rayonnement directionnel ou omnidirectionnel, peuvent être simulées. En plein air, le niveau de pression sonore a été déterminé une surface enveloppante à 1 m de distance dans différents bâtiments industriels. Lors de l'évaluation, chacun de ces 94 points est considéré comme un poste de travail et le niveau de pression sonore d'émission a été respectivement déterminé en appliquant la méthode ISO 11200. L'étude montre que les résultats les plus précis peuvent être obtenus avec l'ébauche de la norme ISO 11205 présentée avec le mesurage triaxial d'intensité du son ainsi qu'avec la norme ISO 11204.

Une étude similaire a été réalisée pour vérifier la norme ISO 3747 pour le mesurage du niveau de puissance sonore selon le procédé par comparaison. L'étude montre qu'une distance des points de mesure garantissant une augmentation de niveau D_{Lf} de 7 dB suffit. L'application d'autres indicateurs ne s'est pas révélée efficace. Sur la base de cette étude, un concept de disposition optimal de positions de sources sonores comparatives et de microphones est proposé.

Mots clés:

Niveau de puissance sonore, niveau de pression sonore d'émission, défaut d'angle, ISO 11200 - série, ISO 3747

1 Introduction

The sound power level and the emission sound pressure level are the most important values for the characterization of noise generated by machines. They are the basis for the evaluation of the acoustic quality and their knowledge is the absolute minimum condition for the assessment of the expected noise impact at working places. The latter refers to facilities in free field as well as to installations in rooms.

Since the coming into force of the machine-directive /1/ the determination and declaration of these parameters is an obligation for the machine producing industry. Corresponding contractual obligations provided, they are taken more and more as a basis in the economic field.

The measurement of these values is regulated in a rather complex number of standards and guidelines. These documents describe as well the uncertainties and deviations. In the sense of their implementation it is of great importance that this system of standards is practical and corresponds to the company's requirements.

With regard to the determination of noise emission values by the manufacturer and the inspection by the user as well as to the application of the noise imission prognosis, there is of course quite a number of unsolved problems left.

The low acceptance in the machine producing industry but as well in companies operating these machines is consisting to a great extent in the fact that the physical context is not easily understandable. In the following we will give some hints which are as well useful for non experts.

An other problem is the relatively complicated measuring procedure for the determination of the two values, especially if the measurement must be done in the installation place in the company's environment. This is the case for all machines that cannot be moved easily. In this context approximate procedures are necessary which are keeping the expenditure of the measurement in acceptable limits and which can be applied in the framework of the quality management in the final control and by the operating staff during the taking-over. However, this requires the taking into consideration of conditions on which the approximate procedures may be applied in the framework of the required exactness. In the following, a number of possibilities for those simplifications which are always based on the involvement of foreknowledge is fundamentally presented. By means of a principal examination depending on the respective kind of machines these approaching procedures can be determined in a specific way and can be taken as alternative methods in the corresponding C-standard.

It is necessary to consider that the measurement of the sound power level with different measurement procedures systematically can result in different values in spite of a correct application of all prescribed corrections in accordance with the relevant standard.

This is especially referring to the typical difference between the measurement results which can be realized with the sound power level - envelopping surface method on one side and with the reverberation chamber - or intensity measurement on the other side. Since this difference caused by the angle error during the measurement according to the sound power level - envelopping surface method can be greater than the deviation allows according to the grade of accuracy depending on the standard, an evident lack has to be noticed here. In the following we will discuss this in a more detailed way and suggest an improvement for further standardization.

In this report, as well the results of several examinations which have been realized with reference to the standards of the series ISO 11200 and to the standard ISO 3747 are represented. On the basis of these results, improvements are suggested which shall lead to more easily applicable, transparent and practice oriented standards for the measurement of noise emission of machines.

2 Sound power level L_{WA} and emission sound pressure level L_{pA}

2.1 What does the sound power level state - definition and application

Sound is like heat or light a form of energy. The energy which is emitted per time unit by a source, for example by a machine, is the sound power. It is measured in watt resp. in joule/sec. (1 watt = 1 Nm/s).

The sound which is radiating from a machine is indicated as sound power resp. - with reference to the values referring to the immission - as sound power level L_w . In this context the following definition is applicable:

$$L_w = 10 \log \frac{P}{P_0} \text{ dB} \quad (2/1)$$

(with P sound power in watt, P_0 reference power in 10^{-12} watt)

The higher the sound power level of a machine is, the more sound energy it will radiate per time unit into the environment. The sound power level quantifies the whole sound that is radiated in all directions.

For a better understanding may serve the following experiment of thoughts:

Assuming that we put on the machine a funnel inside completely reflecting which is directing the whole radiated power into a channel with a cross-section of 1 m^2 , the measurable sound pressure level in this channel would be equivalent in terms of figures to the sound power level.

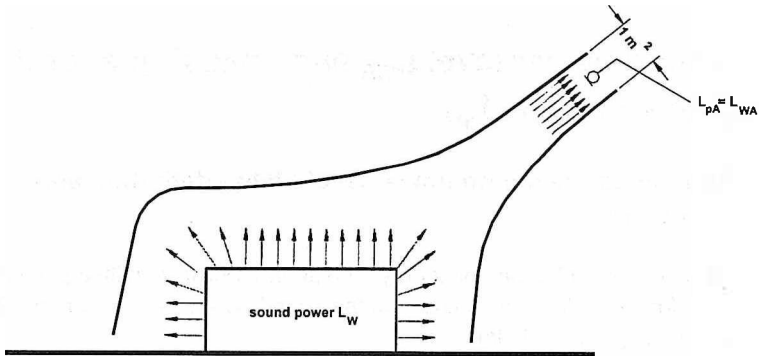

Fig. 2.1 In the channel with a cross-section of 1 m^2 the sound pressure level is equivalent to the sound power level of the source

The sound power level of a big machine which is radiating regularly over its whole surface is higher, the more sound power each single m^2 of this surface is radiating and the bigger this surface is. ***In case of an equivalent sound power per m^2 surface, a machine being as twice as big leads to a sound power level which is by 3 dB higher.*** If one of two machines with the same sound radiation per m^2 of the surface has a twice as big surface than the other, its sound power level will be 3 dB higher.

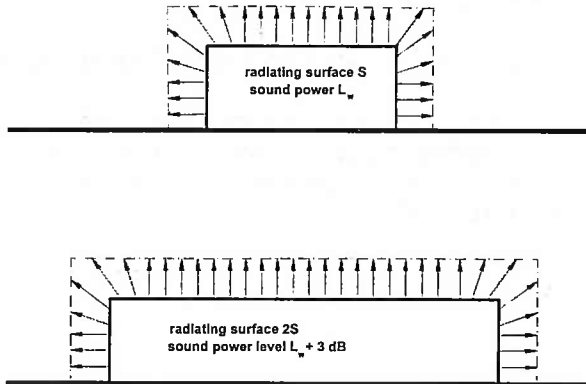

Fig. 2.2 The sound power level is increasing corresponding to the size of the machine

The sound power level of a machine defines the sound power level which is caused at distant immission points

If the machine with sound power level L_w is standing on a reflecting floor, the sound power level caused by the machine in a distance r that is big related to its dimensions is

in free field

$$L = L_w - 8 - 20 \log \frac{r}{r_0} \text{ dB} \quad (2/2)$$

(with r distance in m, r_0 reference distance 1m)



Fig. 2.3 Sound immission at a distance r in free field over reflecting surface

and in buildings

$$L = L_w - 10 \log \frac{A}{A_0} + 6 \text{ dB} \quad (2/3)$$

(with A equivalent absorption area in m^2 and A_0 reference area 1 m^2)

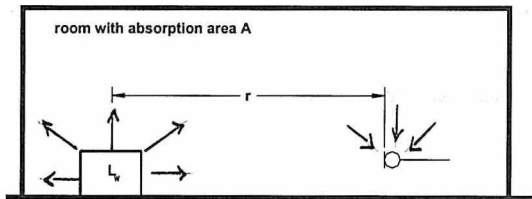

Fig. 2.4 Sound immission at a distance r in a room with absorption area A

Consequently, the sound power level is the most important one-number-value for the characterization of the noisiness of a machine.

2.2 What does the emission sound pressure level state - Definition and application

The emission sound pressure level of a machine is the sound pressure level caused by the machine at the working place under free field conditions.

It is the sound pressure level at the working place of a machine in case this machine would be operated in free field, this means without room influence and without noise impact from other sources.

The emission sound pressure level of a machine determines the sound pressure level at the related operator working place.

In case the machine with emission sound pressure level L_{pA} is standing on a reflecting floor, the sound pressure level caused by the machine results at its operator's working place

in free field

$$L = L_{pA} \quad (2/4)$$

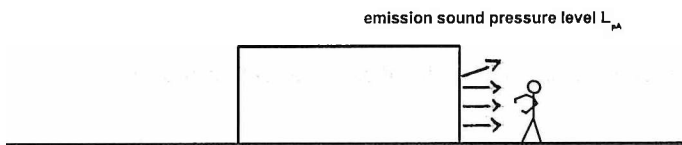

Fig. 2.5 Sound pressure level at the workplace with machine in free field

and in buildings

$$L = 10 \log \left(10^{0.1 \times L_{pA}} + \frac{4}{A} \times 10^{0.1 \times L_{pA}} \right) \text{ dB} \quad (2/5)$$

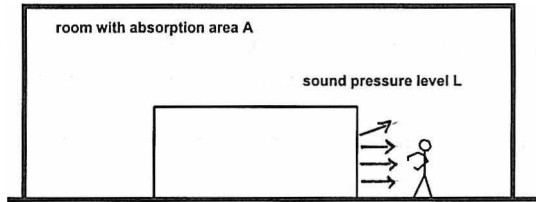

Fig. 2.6 Sound pressure level at the workplace with machine in a room

As relation (2/5) shows, the sound pressure level at the working place of a machine in buildings depends not only on its emission sound pressure level L_{pA} but due to the room influence as well on the sound power level L_{WA} and on the absorption surface A in the building. For the room sound field the whole sound power is relevant and not only the sound power which is radiated in the direction of the working place.

In this context it should be noted that the equations (2/3) and (2/5), strictly speaking, can only be applied to rooms with a diffuse sound field. In all other remaining rooms, they have to be considered only as an approximation. However, this does not change the principle dependance of the sound pressure level on the mentioned parameters.

2.3 How does the noise immission at working places result from the noise emission values L_{WA} and L_{pA}

In case in a room are several machines and working places, the sound level at these working places can be calculated approximately, if the values L_{WA} and L_{pA} for all machines are known.

By means of the mentioned relations (2/2) and (2/5) the partial sound pressure levels of a machine at its own and at all more distant working places can be determined, if conditions of a diffuse field exist.

Practically many machine halls are so flat that the statistic sound field theory is not applicable. In these cases the sound decay curve SAK according to ISO 14257 (ISO/DIS 14 257 „Acoustics - Measurement and modelling of spatial sound distribution curves in workrooms for evaluation of their acoustical performance“) is determined with a suitable calculating method (mirror image or ray tracing method). The sound pressure level caused by a machine with sound power level L_{WA} at one place in distance r is

$$L = L_{WA} + SAK(r) \quad (2/6)$$

Therefore it is necessary to sum up the following partial sound pressure levels energetically to calculate the total sound pressure level at the workplace:

1. The sound contribution of the machine that is operated at this workplace (2/5).
2. The sound contributions of all remaining machines according to (2/6) or - in buildings with diffuse field conditions - according to (2/3)

If it is not the workplace the operator of a machine, contribution 1 can be dropped.

This relations show, what emission value is the more important in a given situation. Since it is finally important to keep the sound levels at the workplaces as low as possible when all machines are in typical operation, all emission values, which have influence on these workplace-levels have to be considered.

These are the sound power level L_{WA} **and** the emission sound pressure level L_{pA} . for all machines with attached operator working places.

In case there is no operators position at a machine, the sound power level is sufficient to describe its noise emission.

It is a special case if machines with attached working places are located typically with such big distances between them, that the noise at the workplace is only determined by the emission of the attached machine. This is the case, for example, if rooms are equipped typically with sound absorbing ceilings or if halls have a very big size. In these cases the application of merely the emission sound pressure level can be useful for the description of the noise emission. This is especially helpful when the emission of big machines have to be measured, because the determination of the sound power level would be very time consuming and therefore expensive.

3 Standards for measurement of noise emission values

3.1 Standards for the measurement of the sound power level

ISO 3740 **Guideline for the use of basic standards and for the preparation of noise test codes.**

ISO 3741 **Determination of sound power levels of noise sources using sound pressure - Precision methods for reverberant rooms**

The sound pressure level caused by the machine is measured at different points in the room (direct method) and is compared with the sound pressure level that is caused by a reference sound source with known sound power level (comparison method).

Advantage: precise measurement with high accuracy

Disadvantage: only for moveable machines that can be brought into the reverberation room. With the comparison method a calibrated reference sound source is necessary.

ISO 3743-1 **Determination of sound levels of noise sources - Engineering methods for special reverberation test rooms.**
Part 1 : Comparison method

The sound pressure level caused by a machine is compared with the known sound pressure level caused by a reference sound source.

Advantage: simple to handle

Disadvantage: for small sources only (dimensions < 1 m), calibrated reference sound source and reverberation room

ISO 3743-2 **Determination of sound levels of noise sources using sound pressure - Engineering method for small, movable sources in reverberant fields - Part 2 : Methods for special reverberation test rooms**

Direct method with more requirements for the test room with reflecting walls as it is the case for part 1

Advantage: simple to handle

Disadvantage: only for small sources (dimension < 1 m), special test room required

ISO 3744 **Determination of sound levels of noise sources using sound pressure - Engineering method in an essential free field over a reflecting plane.**

The machine is operated in an approximately freefield, in a very large room or in a room with many absorbent surfaces. The sound pressure is determined on a box shaped envelopping surface with a distance from the machine surface of normally 1m.

Advantage: With forementioned preconditions in arbitrary rooms practicable and therefore also at the installation-place. The directivity results as by-product.

Disadvantage: Can be time consuming and therefore costly with large machines. Preconditions for the room often not fulfilled.

ISO 3745 **Determination of sound levels of noise sources using sound pressure - Precision method in a free field over a reflecting plane**

The machine is operated in freefield conditions, e.g. a test room with highly absorbent surfaces. The sound pressure levels are determined at measuring points on a spherical or hemispherical envelopping surface with a radius of more than twice the largest machine dimension.

Advantage: very precise

Disadvantage: often not realizable at the usual installation-place. Highly absorbent test laboratory essential.

ISO 3746 Determination of sound levels of noise sources using sound pressure - Survey method employing an enveloping measurement surface over a reflecting plane

Measurement equals ISO 3744, but less requirements with respect of the room.

Advantage: Often feasible at the usual installation-place, no special laboratory necessary, well suited for verification.

Disadvantage: low precision

ISO 3747 Determination of sound power levels of noise sources using sound pressure - Comparison method for use in situ.

The sound pressure level caused by the source under test is compared with the sound pressure level caused by a calibrated reference sound source.

Advantage: very simple and relatively few measuring points even for big machines, therefore a very economical procedure.

Disadvantage: Machine must be operated alone because the background noise must be low. Calibrated reference sound source necessary.

ISO 9614-1 Determination of sound power levels of noise sources using sound intensity - Part 1: Measurement at discrete points.

Enveloping method like ISO 3744 or ISO 3746, but measurement of the sound intensity levels instead of the sound pressure levels.

Advantage: stationary background noise and environmental influences will be eliminated, therefore less requirements for the environment. The measurement according to ISO 9614 is the only possible alternative if extremely unfavorable measurement conditions exist.

Disadvantage: Costly measurement equipment. With this measurement procedure good technical knowledge is required because many indicators have to be checked. Special training for proper execution is unavoidable. In practice often not applicable if noise levels change in time.

ISO 9614-2 Determination of sound power levels of noise sources using sound intensity - Part 1: Measurement by scanning.

Advantage and disadvantage like ISO 9614-1.

3.2 Standards for the measurement of the emission sound pressure level

ISO 11200 Guidelines for the use of basic standards for the determination of emission sound pressure levels at a work station and at other specified positions

ISO 11201 Measurement of emission sound pressure levels at a work station and at other specified positions, Engineering method in an essentially free field over a reflecting plane

The environmental influence is neglected, because the measurement is restricted to nearly free field conditions (free field or large room or highly absorbent room).

Advantage: if applicable, the method is easy to use (use of measured sound pressure directly)

Disadvantage: only applicable with large rooms or rooms with absorbent surfaces. If radiation is directional, the result can be inaccurate even with these requirements fulfilled.

ISO 11202 Measurement of emission sound pressure levels at a work station and at other specified positions, Survey method in situ

An approximative environmental correction similar to the method used in ISO 3744 ,

Advantage: no further sound pressure level measurement necessary to determine the environmental correction, because the latter is calculated from the room properties.

Disadvantage: can be very unprecise, if the main noise sources at a big acoustically not transparent machine are at the opposite side of the work station.

ISO 11203 Determination of emission sound pressure levels at a work station and at other specified positions from the sound power level

Advantage: no additional measurement necessary, if the sound power level has to be measured anyway.

disadvantage: should only be used for the determination of the emission sound pressure level for little handheld machines. In all other cases there is no strong relation between sound power and emission sound pressure level.

ISO 11204 Measurement of emission sound pressure levels at a work station and at other specified positions, Method requiring environmental corrections

The environmental correction is determined from room properties, sound power level and directivity index at the work station.

Advantage: The method is derived from the basic parameters describing the sound field and therefore includes the influence of these values.

Disadvantage: For positions with negative directivity index, that is in screened areas or in directions with low emission the inaccuracy of the method raises. The environmental correction affords the measurement of the mean sound pressure level on an envelopping surface or the sound power level of the machine otherwise determined.

ISO 11205 Determination of emission sound pressure levels at a work station and at other specified positions, Method using sound intensity

This method uses the complete compensation of the intensity flow in ideal diffuse sound fields - an environmental correction is not necessary.

Advantage: No environmental correction, no measurements at other points as the work place or the specified position.

Disadvantage: Costly measurement equipment. With this measurement procedure good technical knowledge is required.. Special training for proper

execution is unavoidable. In practice often not applicable if noise levels change in time. If the sound field is not diffuse and the reverberating sound is not compensated, the inaccuracy raises.

3.3 Remarks for a proper choice of the measuring method

The sound power level is determined in most cases with ISO 3744 or 3746, because this method can be applied in nearly all surroundings. The measurement of sound intensity according to ISO 9614 will remain for professional users in the next few years, because it affords much more knowledge and experience than the other methods.

A very interesting method because of its simplicity is the measurement according to ISO 3747. The method uses the information of the room sound field that is dominated by reflections, and different from the envelopping surface method even with big machines only few measuring points are necessary. An investigation about the accuracies using this method is presented in chapter 7.

The emission sound pressure level is determined by correcting the sound pressure level measured at the operators position of a machine from the influence of background and reflected sound. This last correction K_3 is the equivalent to the K_2 correction for the measurement of sound power level with the envelopping surface method. The procedure described in ISO 11204 uses the same prepositions for the determination of the correction at a single point or in a restricted area, that are valid when the correction K_2 is determined for the mean level on the envelopping surface. The ISO 11204 procedure takes in account the directivity of the radiation, because this plays a much more important role when correcting levels at a defined point than in the case of correcting the mean level on an envelopping surface. All other methods described with the ISO 11200 series are approximations, which are applicable only in the limits given by the standard. (It is clear that practically there are also strong limits for the use of ISO 11204 - it is only stated that these are not the consequence of neglectings in the derivation of K_3). An investigation about the accuracies using this method is presented in chapter 6.

4 Approximate methods for the measurement of emission values

The measurements for the determination of emission values for declaration purposes should be carried out with a standardized method whenever possible. In many other cases it may be suitable to apply one of the above mentioned approximate methods. Some of these methods have been tested and proved to be helpful especially when measuring sound emission of big machines (12/,13/).

4.1 Measurement on partial surfaces with different density of measuring points

According to the standards for the determination of the sound power level by measuring the sound pressure level on an envelopping surface the measuring points have to be arranged regularly. Only by this the determination of the average sound pressure level on the measuring surface is possible by means of simple level averaging. In case of big machines which radiate sound mainly on one side or in limited surface areas, the necessary time expenditure can be reduced considerably, if a lower density of measuring points is chosen in the regions with low and uniform radiation.

In this case the whole measuring surface S should be subdivided in single partial surfaces S_k , and the measuring points i are arranged in each of these partial surfaces with different density.

In example Fig. 4.1 only one measuring point is arranged on the low radiating top surface S_5 of the machine, whereas in the most interesting working area S_1 5 points are located.

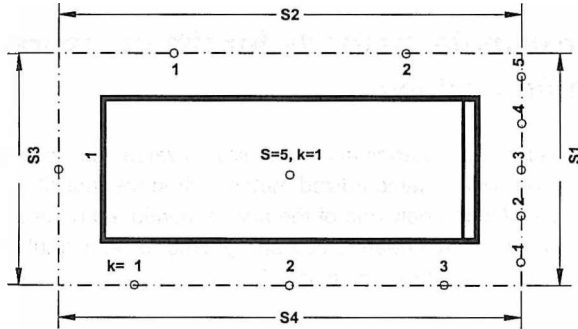

Fig. 4.1 arrangement of measurement points with different density

The mean sound pressure level on the measuring surface is calculated in this case with

$$\bar{L} = 10 \lg \left(\frac{1}{\sum_k S_k} \times \sum_k \left(\frac{S_k}{N_k} \times \sum_i 10^{0.1 \times L_{k,i}} \right) \right) \text{ dB} \quad (4/1)$$

(with N_k number of partial surfaces, $L_{i,k}$ sound pressure level at point i in partial area k).

4.2 Use of symmetry relations

In many cases it is known from preliminary measurements or by taking into account the symmetry of a construction, that the mean sound pressure levels at one side of the machine equal those at the other side. In these cases it is possible in accordance with the basic standards ISO 3744 and 3746 to measure on one side and to attach this measured values also to the equivalent points on the other side.

4.2.1 Determination of the environmental correction K_2 with the reference sound source on a smaller measuring surface

When measuring the environmental correction K_2 with the reference sound source method and with a big machine, it is often impossible to find a free area with comparable acoustic conditions nearby in the hall, where the emission from the reference sound source can be measured with the same sized envelopping surface as it was used when measuring at the machine.

In these cases, it may be useful to determine the environmental correction $K_{2,1}$ which is related to a smaller measurement surface, when the reference sound source is used. After that the corresponding environmental correction $K_{2,2}$, that is related to the bigger measurement surface applying to the machine is determined according to

$$K_{2,2} = 10 \lg \left[1 + \frac{S_2}{S_1} \times (10^{0.1 \times K_{2,1}} - 1) \right] \text{ dB} \quad (4/2)$$

(with S_1 measurement surface of reference sound source, S_2 measurement surface of machine).

4.2.2 Measurement on partial measuring surfaces

When measuring the sound power level of big machines with well defined and restricted radiating areas, it is often possible to allocate to these areas single smaller partial measurement surfaces. In the example in Fig. 4.2 this is the area of the motor at the backside of the machine and the whole front area

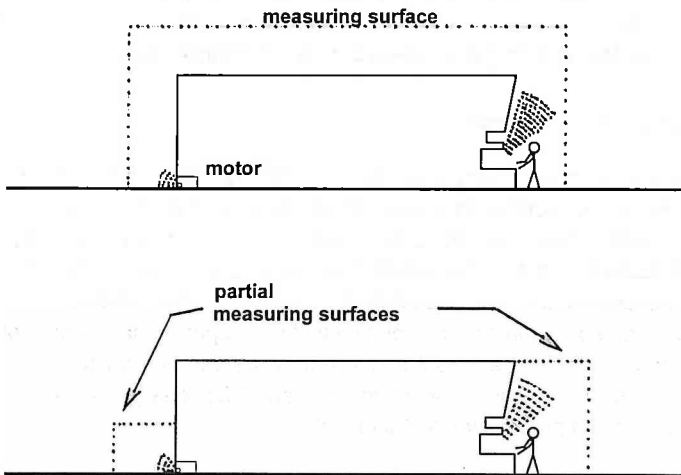

Fig. 4.2 Two partial measuring surfaces at noisy areas instead of one big measuring surface

However, this method is only possible if the source areas do not influence one the other because the sound of a partial source in case of the measurement of the other

source has to be treated like a background noise. In most of these cases one partial source can not be measured with the other partial source out of operation.

There is still a number of further possibilities for the reduction of measurement expenditure, if the standardized procedure during the repeated and regular control measurement in the manufacturing company or during the take-over of the machine is not possible or requires too much time. This applies to the application of the reverberation chamber method in industrial halls with a low absorption or the measurement at few specified points of a machine in the course of the quality security in production. In many cases it is possible to get sufficient accurate results when the method used has been qualified in preliminary examinations.

4.2.3 Measurement on short distance surfaces

Many machines are coupled mechanically, electrically or by the material flow because they are integrated in a complete production line. In these cases the sound radiated by the machines in front or behind the machine in question may result in a background noise level on the measuring surface in 1 m distance, that can not be eliminated. In this and in many comparable situations a measurement in very short distances of about 10 cm may solve the problem, if the influence of background noise is reduced to an extent, that no correction is necessary. This technique has been tested with machines and transport systems in bottling industry /3/. In most of the examined cases a correction of about 3 dB was necessary to take into account the angle error (see next chapter) when measuring in short distances.

4.2.4 Measurement in openings

Some machines are partially or even completely covered by an enclosure. In this cases most of the sound energy that determines the sound pressure level in the surrounding is radiated from the remaining open surfaces and openings that are necessary for material flow or for other reasons. If the measurement in a 1m distance is not possible, because there is too much background noise, it may be advantageous to measure the mean sound pressure level directly in the open surface areas of the enclosure. For each opening the partial sound power level is determined from this mean sound pressure level and the opening area. The energetic sum of all contributions is the sound power level of the machine.

This technique has also been examined with machines in bottling industry, in packaging plants and with a big waste shredder machine /3/ and has proved to be very effective. If it shall be used generally with a machine family, it is advantageous to derive a near field correction as difference between sound pressure and sound intensity level in the opening areas and to describe the method and the correction for general use in the machine specific safety standard. In the case of the bottling

machines a mean short distance correction of 3 - 4 dB was necessary to come to sufficient accurate results. By using this method, the sound power level of a bottling machine can be determined with all coupled machines in a line in full operation.

5 Systematical deviations dependent on the measurement method and their correction

In the following some aspects of uncertainty related to the different measurement methods are discussed. Although the accuracy of emission measurements have been investigated by different authors (e.g. /4/, /5/ and /6/), there is no overview that shows the relation between the different deviations.

5.1 The true value of the sound power level

The „true“ sound power level of a source is determined by integration of the dot product of the sound intensity vector \vec{J} and the normal unity vector \vec{n} around a closed envelopping surface (Fig. 5.1)

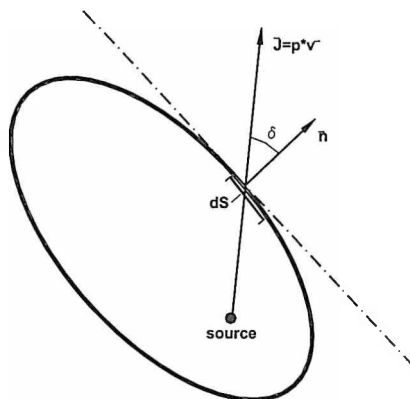

Fig. 5.1 Sound power as integral over a closed envelopping surface

In a plain sound wave - this means in a distance which is large compared with the dimensions of the source - the sound intensity is equivalent to the product from sound pressure p and particle velocity v . Consequently, the radiated sound power is

$$P = \oiint \vec{J} \cdot \vec{n} |dS| = \oiint p \cdot \vec{v} \cdot d\vec{S} \quad (5/1)$$

Thus the sound power is a one number value, describing the energy flow per time unit into the environment. The sound power level is then calculated by (2/1) - see chapter 2.

Machines are sound sources which are typically situated on a reflecting surface.

In case the sound source is small in relation to the wave length of the radiated sound and the radiation mechanism is not influenced by the pressure of the surrounding air, the direct and the reflected sound wave interfere in phase and the sound pressure level in the environment is increased 6 dB by the floor reflection. Since the integral (5/1) extends only over a hemisphere, the reflection leads in this case only to an increasing of the sound power level of the source of 3 dB.

However, this is to a great extent a theoretic special case. Machines radiate from different points incoherent sound and furthermore they are in most cases big compared to the distance of the reflecting surface. This results in an energetic superposition of direct and reflected sound. In this case the doubled intensity is integrated over the halved surface - the radiated sound power is not influenced by the reflecting surface.

In case the envelopping surface is a sphere with a radius which is great compared to the source dimension and the source is situated in the centre, the integral (5/1) can be replaced by

$$P = \frac{1}{\rho_0 c} \oint_S p^2 d\bar{S} \quad (5/2)$$

If the sound power level is determined by a measurement of the sound pressure level on an envelopping surface, the equality of (5/1) and (5/2) is used. Each deviation of the above mentioned conditions for the validity of this relation consequently leads to corresponding uncertainties. If the sound intensity level is determined with an intensity probe perpendicular to the measurement surface, this corresponds to the direct measurement according to (5/1). The requirement of a large measuring distance compared to the source dimensions does not exist in this case.

The sound power of a machine or a technical installation is in the sense of these specifications a value which allows to determine the sound pressure level in a greater distance in rooms as well as in free field. Each deviation of the noticed value from the „true“ value results in a false assessment and, consequently, has to be treated as an error. In view of systematic errors, it is suitable to determine their

functional dependence on the parameters and to develop on this basis corrections for the adjustment of the results.

5.2 The angle error when measuring the sound power level according to the sound pressure enveloping surface method

5.2.1 The reason of an angle error

If the sound power level is determined by the measurement of the sound pressure level on an enveloping surface, the validity of the relation

$$\vec{J} \cdot d\vec{S} = \frac{p^2}{\rho c} \cdot d\vec{S} \quad (5/3)$$

can be assumed. However, this is apparently only correct if the sound pressure square p^2 in each surface element is caused by a sound intensity flow which is perpendicular to this surface. Each intensity flow running in a parallel way to the measuring surface increases the sound pressure, but does not lead to a sound energy flow through this surface.

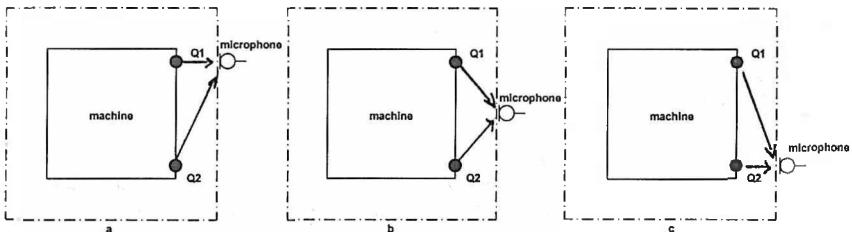

Fig. 5.2 measurement in front of source Q1 (a), between Q1 and Q2 (b) and in front of Q2 (c)

In case that extended areas of the surface of a machine radiate sound, it is not possible to select a microphone position by means of which a corresponding angle error could be avoided. In Fig. 5.2 all three microphone positions a, b and c lead to the same overestimation of the sound power flowing through the respective measuring surface element. In case that all microphone positions on the measuring surface are included, the middle angle between sound ray and measuring surface and, consequently, the angle error mainly depend on the relation between machine dimension and microphone distance.

From (5/3) results the error due to a sound ray crossing the measuring surface with an angle α to the normal of the surface

$$\Delta L = 10 \lg(|\cos(\alpha)|) \text{ dB} \quad (5/4)$$

Fig. 5.3 shows this error in dependence of this angle α

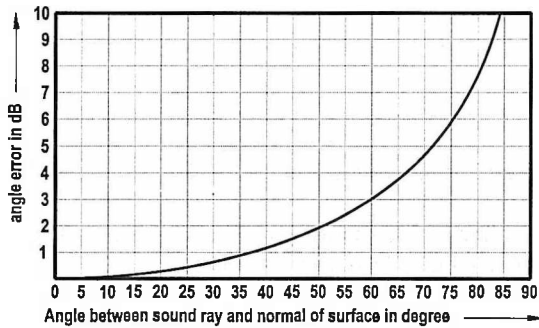

Fig. 5.3 Angle error in dependence of angle between ray and normal of surface

5.2.2 The smallest possible angle error in a box shaped measuring surface

Hence, the angle error is caused because the sound rays don't cross the measuring surface vertically in all cases. Whereas the sound pressure square p^2 from which the radiated sound power is calculated, does not depend on the angle of incidence on the measuring surface, the effectively radiated sound power becomes the smaller, the more plain the sound rays cross this measuring surface.

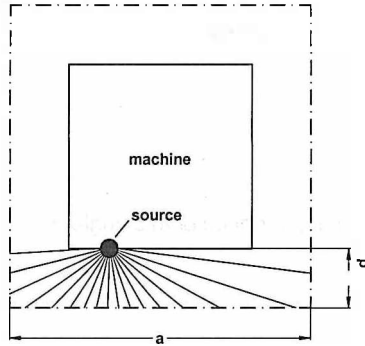

Fig. 5.4: Sound rays emanating from a source on the machine surface

It is evident that the error is increasing with the relation a/d .

In the following this error is calculated approximately. The starting point is a single point sound source Q on the surface of the machine.

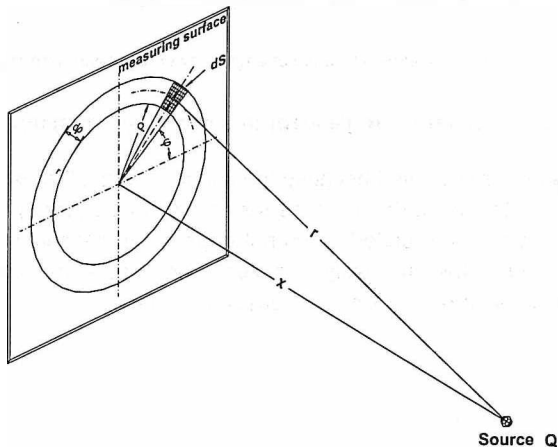

Fig. 5.5 Determination of the sound power transmitted through the measuring surface by measurement of p^2

With the square measuring surface in figure Fig. 5.5 - assuming that the side length is a - the sound power which is radiated from the source Q in this direction shall be determined. The whole sound power of the source shall be P .

The sound wave starting from Q leads at the surface element dS

$$dS = \rho \cdot d\rho \cdot d\varphi \quad (5/5)$$

to a sound intensity of

$$|\vec{J}| = \frac{P}{4\pi r^2} = \frac{P}{4\pi(x^2 + \rho^2)} \quad (5/6)$$

In case the sound power which is crossing the surface element dS is determined from the sound pressure level without taking into consideration the angle of incidence, this leads to

$$d\tilde{P}_w = |\vec{J}| \cdot |dS| = \frac{P}{4\pi} \cdot \frac{\rho \cdot d\rho \cdot d\varphi}{(x^2 + \rho^2)} \quad (5/7)$$

The „sound power“ which is determined by means of a circular area of radius R by measurement of sound pressure is as follows:

$$\tilde{P}_w = \frac{P}{4\pi} \cdot \int_0^{2\pi} d\varphi \int_0^R \frac{\rho \cdot d\rho}{x^2 + \rho^2} \quad (5/8)$$

The integration leads to

$$\tilde{P}_w = \frac{P}{4} \cdot \ln\left(1 + \frac{R^2}{x^2}\right) \quad (5/9)$$

This result shows that the sound power calculated will exceed all limits, if R increases. If we enclose the source between two infinitely extended plain measuring surfaces, each of those is crossed in reality by a sound power of $P/2$. This proves that the angle error is unlimited.

In case of a quadratic measuring surface with a side length a the radius R of an equivalent circular surface element is

$$R \approx \sqrt{\frac{a^2}{\pi}}$$

and if the sound source Q is in the midpoint of a cubic measuring surface

$$x \approx \frac{a}{2}$$

From (5/9) the sound power which is measured with 6 square shaped surfaces is

$$\tilde{P}_W = \frac{6 \cdot P}{4} \cdot \ln\left(1 + \frac{4}{\pi}\right) \quad (5/10)$$

Hence, the angle error ε'_W which is expressed in dB is as follows:

$$\varepsilon'_W = 10 \cdot \lg\left(\frac{\tilde{P}_W}{P}\right) = 10 \cdot \lg\left[\ln\left(1 + \frac{4}{\pi}\right)^{\frac{3}{2}}\right] = 0.9 \text{ dB} \quad (5/11)$$

If the sound power level of a point source is calculated with the sound pressure enveloping surface method using a cube-shaped measuring surface with side a , the angle error is 0.9 dB independent of this side length a . If the point source is situated on a reflecting floor, this applies to a measuring surface with quadratic ground plan and a height which corresponds to the half of the side length of the square.

5.2.3 The angle error with reference sound source or machine using a box-shaped measuring surface

In practice the angle error which is caused by using a box-shaped measuring surface with any dimensions and with a measuring distance of 1 m is of interest. In the case that the environmental correction is calculated with a reference sound source, also the angle error should be known which is caused when the machine is replaced by this reference sound source which has to be considered as a point source.

For the determination of this relation between source dimensions and measuring distance on one side and the resulting angle error on the other side a computer program has been developed. By means of this program a box shaped sound source can be simulated and the sound immission at the measuring points of a box-shaped enveloping surface can be calculated. The machine with a sound power level L_{WA} is considered as a sound impermeable box whose surfaces is splitted in such small partial surfaces dS that each partial surface can be considered as a point source with sound power level

$$dL_{WA} = L_{WA} + 10 \cdot \lg\left(\frac{dS}{\sum dS}\right) \quad (5/12)$$

For the calculation of the sound immission at an immission point of the measuring surface the contributions of all point sources located on the surface of the machine are summed up energetically. This corresponds to an incoherent radiation of all surface areas. For the calculation of the share of sound energy produced by a point source at an unscreened immission point the radiation in the halfroom is assumed and only the geometric distance attenuation D_s with

$$D_s = -11 - 10 \cdot \lg\left(\frac{s}{s_0}\right) \text{ dB} \quad (5/13)$$

is taken into consideration. If an immission point is screened from the radiating point source by the machine box, the diffracted shares of sound energy are calculated by the application of the screening algorithms according to VDI guideline 3720 (now as well ISO 9613-2). Since with the regular radiation of all surface areas the diffracted shares of sound energy do not essentially influence on the result at the immission points we renounce a detailed description of this screening calculation.

For the calculation of the angle error the measurement according to the envelopping surface method is simulated numerically (the method is described in /7/). The measurement with reference sound source according to figure 14 is simulated by calculating the immission from this point source, whose sound power is assumed with L_{WA} , at all points of the measuring surface. With mean sound pressure level L on the measuring surface S the sound power level determined with this simulation experiment is

$$L_{WA,c} = L + 10 \cdot \lg\left(\frac{S}{S_0}\right) \text{ dB} \quad (5/14)$$

The angle error ε'_W in dB is

$$\varepsilon'_W = L_{WA,c} - L_{WA} \quad (5/15)$$

The simulation of the measurement with a machine is realized in a similar way. The sound energy contributions generated by all surface elements dS of the machine surface are summed up energetically at every immission point in this case.

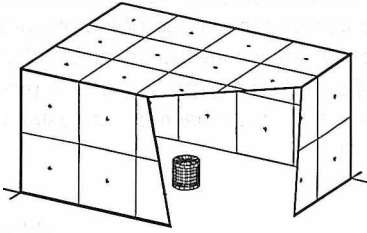

Fig. 5.6 reference sound source in measuring surface

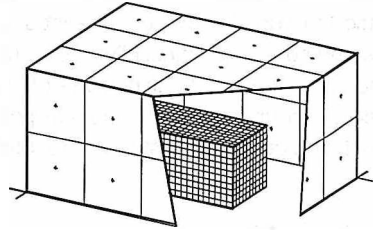

Fig. 5.7 radiating machine in measuring surface

Fig. 5.6 shows the reference sound source, Fig. 5.7 the machine with radiating surface elements positioned in a box-shaped measuring surface. The calculation has been realized with a variation of the dimensions of the envelopping surface (reference sound source) resp. the envelopping surface of the machine. In the latter case a measuring distance of 1 m was provided. In tables 1 and 2 the results are represented.

Tab. 5.1 Angle error ϵ'_w in dB when measuring the sound power level of a reference sound source corresponding to Fig. 5.6 with the sound pressure envelopping surface method

no.	dimensions of measuring surface						
	length	breadth	height				
			2	3	4	5	6
1	3	3	1.0	1.2	1.5	1.6	1.7
2	4	3	1.0	1.2	1.4	1.6	1.7
3	6	3	1.2	1.4	1.6	1.8	1.9
4	10	3	1.6	1.8	2.0	2.2	2.3
5	18	3	2.0	2.2	2.4	2.6	2.8
6	34	3	2.2	2.5	2.8	3.0	3.2
7	66	3	2.4	2.7	2.9	3.2	3.4
8	4	4	0.9	1.0	1.2	1.4	1.5
9	6	4	1.0	1.1	1.2	1.4	1.5
10	10	4	1.4	1.4	1.5	1.7	1.8
11	18	4	1.8	1.8	2.0	2.2	2.3
12	34	4	2.2	2.2	2.4	2.6	2.7
13	66	4	2.3	2.4	2.6	2.8	3.0
14	6	6	1.1	0.9	1.0	1.1	1.2
15	10	6	1.4	1.1	1.1	1.1	1.3
16	18	6	1.8	1.5	1.5	1.6	1.7
17	34	6	2.2	1.9	1.9	2.0	2.1
18	66	6	2.4	2.2	2.2	2.3	2.5
19	10	10	1.7	1.1	0.9	0.9	0.9
20	18	10	2.2	1.6	1.3	1.1	1.1
21	34	10	2.6	2.0	1.8	1.6	1.6
22	66	10	2.8	2.3	2.1	2.0	2.0
23	18	18	2.7	2.0	1.5	1.2	1.0
24	34	18	3.2	2.5	2.0	1.7	1.5
25	66	18	3.5	2.9	2.4	2.2	2.0
26	34	34	3.8	3.1	2.6	2.2	1.9
27	66	34	4.2	3.6	3.1	2.7	2.4
28	66	66	4.9	4.2	3.7	3.3	3.0

The result of an analytic derivation in the last paragraph is confirmed by this numeric calculation.

For the measuring surfaces 4m/4m/2m, 6m/6m/3m and 10m/10m/5m the angle error of 0,9 dB is determined.

In case of the measurement of the reference sound source a considerable influence of the box shape resp. of the dimensions must be noticed. This is as well evident because the lowest possible angle error of 0.9 dB can be forced for each size of the measuring surface with the dimensions $X/X/0.5X$. The possible maximum error is to be expected in the same measuring surface size if two dimensions have a minimal size and the third dimension a maximum size.

Tab. 5.2 Angle error ε'_w in dB when measuring the sound power level of a machine with given dimensions and a measuring distance 1m corresponding to Fig. 5.7 with the sound pressure envelopping surface method

no.	dimensions of machine in m						
	length	breadth	height				
			1	2	3	4	5
1	1	1	1.1	1.3	1.4	1.6	1.8
2	2	1	1.4	1.6	1.8	1.8	2.0
3	4	1	1.6	1.8	1.9	2.1	2.3
4	8	1	1.9	2.1	2.3	2.4	2.6
5	16	1	2.1	2.4	2.6	2.8	3.0
6	32	1	2.2	2.6	3.0	3.3	3.4
7	64	1	2.7	3.2	3.5	3.7	3.8
8	2	2	1.7	1.9	2.1	2.1	2.2
9	4	2	1.9	2.1	2.1	2.2	2.3
10	8	2	2.2	2.3	2.5	2.5	2.6
11	16	2	2.4	2.6	2.7	2.9	3.0
12	32	2	2.5	2.7	3.0	3.3	3.4
13	64	2	2.7	3.2	3.4	3.7	3.7
14	4	4	2.1	2.2	2.2	2.4	2.5
15	8	4	2.3	2.4	2.4	2.5	2.6
16	16	4	2.6	2.7	2.7	2.9	3.0
17	32	4	2.7	2.9	3.1	3.3	3.4
18	64	4	2.8	3.2	3.3	3.6	3.7
19	8	8	2.6	2.6	2.7	2.7	2.7
20	16	8	2.9	2.9	2.9	2.9	3.0
21	32	8	3.0	3.1	3.2	3.3	3.4
22	64	8	3.4	3.5	3.6	3.7	3.8
23	16	16	3.3	3.3	3.3	3.3	3.3
24	32	16	3.7	3.7	3.7	3.7	3.7
25	64	16	4.1	4.1	4.1	4.1	4.1
26	32	32	4.2	4.2	4.2	4.2	4.2
27	64	32	4.6	4.6	4.6	4.6	4.6
28	64	64	5.1	5.1	5.1	5.1	5.1

By means of these values the results of a determination of sound power levels with the sound pressure envelopping surface method can be corrected. However, this is only suitable if the radiating areas of the machines are located on the surface. Machines with a sound transparent structure which have the radiating sources within this structure lead to a lower angle error.

The influence of the sound source distribution on the size of the angle error which has been supposed in earlier times by some authors can not be confirmed by this examination. It is quite insignificant whether the whole sound power of the machine is realized by single point sources located at any places or by the regularly distributed radiation of the whole surface. This is as well evident because the latter is only an additive superposition of the former.

The summary of all numerical simulations for the reference sound source according to Tab. 5.1 shows the diagram in Fig. 5.8. The angle error is here indicated in dependence of the size of the measuring surface. The same context is shown in Fig. 5.9 for the measurement of the machine according to Tab. 5.2. In this diagram the angle error is indicated for all examined machine geometries as function of the logarithmic quotient of the machine surface and the square of the measuring distance.

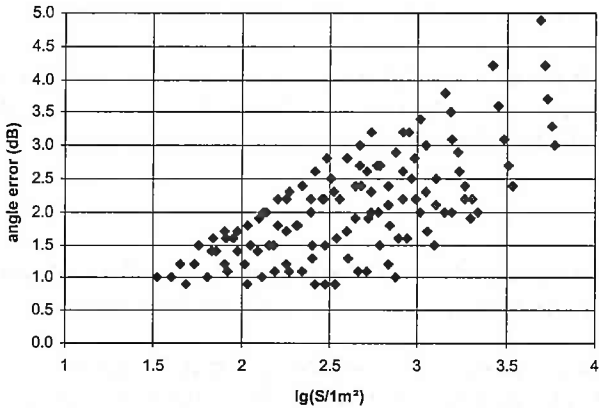

Fig. 5.8 Angle error for the measurement of the sound power level of a reference sound source (with S area of measuring surface in m^2)

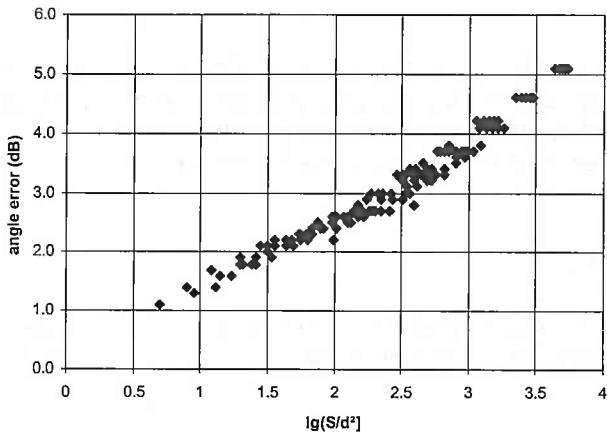

Fig. 5.9 Angle error for the measurement of the sound power level of a machine (with S area of reference box surface in m^2 , d measuring distance in m)

In case of the same values for the machine surface and the measuring distance differences in the angle error until approx. 0,5 dB may emerge due to the different form of the reference surface box. As an approaching formula the following is suitable:

$$\varepsilon'_W \approx 1.36 \cdot \lg\left(\frac{S_m}{d^2}\right) \text{ dB} \quad (5/16)$$

with S area of reference surface

This is as well the difference which is expected during the measurement according to the sound pressure method (ISO 37 44 or 3746) and according to the sound intensity method ISO 9614-1 or ISO 9614-2).

5.3 The total correction of the angle error and the influence of the environment

As shown above, during the measurement according to the sound pressure enveloping surface method for a machine with the real sound power level P a false value \tilde{P}_W is received caused by the angle error ε'_W because the sound rays do not cross the measuring surface vertically. The relative error is as follows

$$\varepsilon_W = \frac{\tilde{P}_W - P}{P} \quad (5/17)$$

\tilde{P}_W consequently is the apparent sound power which results from the measurement according to ISO 3744 or 3746 due to the angle error - if all the other deviations can be neglected. From (5/17) and the definition of the sound power level results the relation between the relative error ε'_W and the corresponding deviation referring to levels

$$\varepsilon'_W = 10 \cdot \lg(1 + \varepsilon_W) \text{ dB} \quad (5/18)$$

Therefore the true sound power level is exceeded with ε'_W by the measured sound power level. Vice versa the linear relative deviation is received from the level deviation by

$$\varepsilon_W = 10^{0.1 \cdot \varepsilon'_W} - 1 \quad (5/19)$$

If a machine whose measurement in free field results in a angle error influenced sound power \tilde{P}_w , is located in a room and the measurement is repeated with the same measuring surface, due to room influence a further deviation is produced. Due to the reflections at walls, ceiling and other surfaces, at the measuring points of the envelopping surface emerges an additional share of sound energy which is depending only on the „true“ sound power P of the machine but not on the share $\varepsilon_w \cdot P$ which is caused by the faulty measurement.

This deviation due to the environmental influence is

$$\varepsilon_U = \frac{\tilde{P}_U - P}{P} \quad (5/20)$$

and correspondingly expressed as level

$$\varepsilon'_U = 10 \cdot \lg(1 + \varepsilon_U) \text{ dB} \quad (5/21)$$

\tilde{P}_U consequently is, on the given measuring surface, the apparent sound power which is only „stated“ by the sound pressure increase that is caused by reflections. It formally results (with P_d direct sound, P_{ref} reflection sound) from

$$\tilde{P}_U = \frac{1}{\rho_0 \cdot c} \cdot \iint_S (p_d^2 \cdot \cos(\delta) + p_{ref}^2) \cdot dS = \frac{1}{\rho_0 \cdot c} \iint_S p_d^2 \cdot \cos(\delta) dS + \frac{1}{\rho_0 \cdot c} \iint_S p_{ref}^2 \cdot dS \quad (5/22)$$

and

$$\tilde{P}_U = P + \varepsilon_U \cdot P = (1 + \varepsilon_U) \cdot P \quad (5/23)$$

This apparent sound power derivating from the environmental influence would be measurable if the sound pressure squares would be determined which are caused by the angle corrected sound rays generated during the first sound passage from inside to outside. Due to the measurement which is not free from angle errors on the box shaped measuring surface and the back effect of the room, as a result of the measurement of the sound power level according to the sound pressure envelopping surface in rooms emerges with the deviations that are defined independent from each other

$$\tilde{P}_{w,U} = P \cdot (1 + \varepsilon_w + \varepsilon_U) \quad (5/24)$$

The whole correction results from the single corrections in dB

$$\varepsilon'_{w,U} = 10 \cdot \lg(10^{0,1 \cdot \varepsilon'_w} + 10^{0,1 \cdot \varepsilon'_U} - 1) \text{ dB} \quad (5/25)$$

Example:

A punch press with dimensions 3 m x 1.5 m x 5 m is located in a room leading to an environmental influence K_2 of 6 dB. From Tab. 5.2 or the relation (5/16) with the reference box surface of 49.5 m² an angle error of 2.3 dB is determined.

Consequently, the total correction is according to (5/25)

$$\varepsilon'_{W,U} = 10 \cdot \lg(10^{0.1 \cdot 2.3} + 10^{0.1 \cdot 6} - 1) \text{ dB} = 6.7 \text{ dB} \quad (5/26)$$

Consequently, the angle error does not play a role in this case since it is covered by the environmental influence.

This changes if the same press is located in a large absorbent room with nearly neglectable environmental influence of 0,5 dB. In this case the total correction is:

$$\varepsilon'_{W,U} = 10 \cdot \lg(10^{0.1 \cdot 2.3} + 10^{0.1 \cdot 0.5} - 1) \text{ dB} = 2.6 \text{ dB} \quad (5/27)$$

This value is determined completely by the angle error. The influence of one deviation or the corresponding correction, consequently, depends on the height of the other.

5.4 Summary - proposal for a standardized total correction

Consequently, the involvement of the described relations in the determination of sound power levels of machines according to the sound pressure enveloping surface method requires the following procedure, if systematic deviations between results based on sound pressure or on intensity measurements shall be prevented.

1. Determination of the environmental correction K_2 ($= \varepsilon'_U$). This is realized by the application of the statistic correction or by the determination with the reference sound source according to ISO 3744/3747. In the latter case - exceeding the method described in the standard - a correction of the angle error according to table 1 has to be applied in the determination of K_2 .
2. Determination of the angle error ε'_W by taking into account the machine dimensions according to Tab. 5.2 or relation (5/16).
3. Calculation of the total correction according to (5/25) or a table derived from it.

Such an approach with a new organization of the standards is an important task for the near future. This revision should end the practice of splitting up the measurement techniques in such an unsystematic variety of different standards, as it was proposed by /8/. A homogenous link between the different methods and an uncertainty that is a continuous function of the parameters would be helpful in the declaration and verification of sound emission values.

6 Examinations regarding the accuracy of the standard series ISO 11200 for the determination of the emission sound pressure level

6.1 Scope

The EC machine directive requires for machines the declaration of noise emission values. This declared value is the sound power level, if the emission sound pressure level exceeds 85 dB(A). Therefore the emission sound pressure level has to be determined anyway. In the standards ISO series 11200 (11200 - 11204) different methods for the calculation of this important emission value of machines are specified. Principally, they are based on different methods for the correction of the measured values from the influence of the room. A comparison of these different methods is tried in /9/.

In ISO 11204 this environmental correction K_3 is derived from the parameters of sound source and sound field (this method has been derived and presented in /2/). However, this derivation is based like the derivation of the K_2 correction according to ISO 3744 on the hypothesis of a diffuse sound field. In /10/ and /11/ some aspects of ISO 11204 are discussed.

According to ISO 11205 the sound intensity level is measured and it is assumed, that the shares of sound energy with regard to the sound power flow through the surface perpendicular to the intensity probe axis completely compensate themselves. Therefore a completely diffuse sound field in the room is a prerequisite. The use of the intensity method to determine the emission sound pressure level has been treated in /12/, /13/, /14/, /15/ and /16/.

All the other standards 11201 to 11203 are approximations by means of which deliberate neglections have been realized. In the application of these standards the respective range of validity must be considered. Independent of this valuation there are no hints resulting from practice about the actually reachable accuracy when using these standards. With the following description of the examination, it is intended to close this gap at least partially. A sound source radiating broad band noise is used as a „model machine“ and installed in different industrial halls. The size of this source is comparable to the size of typical production machines and it can radiate noise with and without directivity. In each industry hall the emission sound pressure level is determined according to the different standards of the ISO 11200 series.

6.2 Description of the procedure

With the first step a sound source with sufficient size and with constant emission has been developed which can be put in different rooms and which can be adjusted to two different states of radiation with and without directivity. After several preliminary tests a Ford Galaxy has been selected. The backside seats have been removed and a sufficient powerful Dodecaeder-loudspeaker has been installed. Both states have been produced by completely closed windows - as far as possible non-directional radiation - and with one window open - strongly directional radiation. The Dodecaeder-Loudspeaker has been supplied with a usual noise generator - power amplifier combination.

The noise emission of this vehicle which with regard to it's size corresponds to a typical machine in industrial use has been determined according to the envelopping surface method with a measuring surface in a distance of 1 m in free field as well as in 6 different halls. On the envelopping surface a measuring point has been located in each surface element of 1m². Totally, 94 measuring points have been used.

In both vehicle states - non-directional and directional radiation - a complete measurement has been realized. The measurement has been carried out with an intensity probe using a two channel realtime-analyzer. For each measuring point a sound pressure spectrum and a sound intensity spectrum has been saved.

For each room the frequency dependent reverberation time and the sound decay curve according to ISO/DIS 14257 has been measured.

In a second step a software program has been developed which can access to these saved data , takes one of the 94 envelopping surface points of the hall measurement as representative for the operator's position and which determines for this point the emission sound pressure level at the working place according to one of the methods ISO 11201 - 11205 (The proposal for the ISO 11 205 at the time of this examination uses the sound intensity level directly and without any correction as emission sound pressure level. In a later development of this standard the measurement with three axes and the determination of the maximum intensity flow from these three measurements is recommended - this was tested additionally).

The deviation of the corrected value from the true free field value for the regarded correction method was saved as third octave band frequency spectrum.

This method was constantly repeated and each of the 94 envelopping surface points one after the other was considered to be the operators position. With every start of the calculating program for a selected radiation state and for the choosen method of environmental correction 94 third octave band spectra of the deviations as well as

two third octave band spectra for the mean deviations and for the standard deviations are saved.

The deviations in third octave bands, however, are only in a by-product - they are not a subject of this examination. Since the accuracy in the determination of the emission sound pressure level shall be examined and this value is an A-weighted sound pressure level, exclusively the deviations of the A-weighted sound pressure level are of interest.

6.3 The vehicle as model machine

6.3.1 The measurement setup

In the rear part of the Ford Galaxy the seats have been removed and a dodekahedron loudspeaker with defined position and orientation was installed.

The dimensioned views of the car with the measuring points on the enveloping surface are shown in Fig. 6.1 to Fig. 6.5. The area of this enveloping surface with the dimensions 6.62 m x 3.81 m x 2.73 m is 82.2 m².

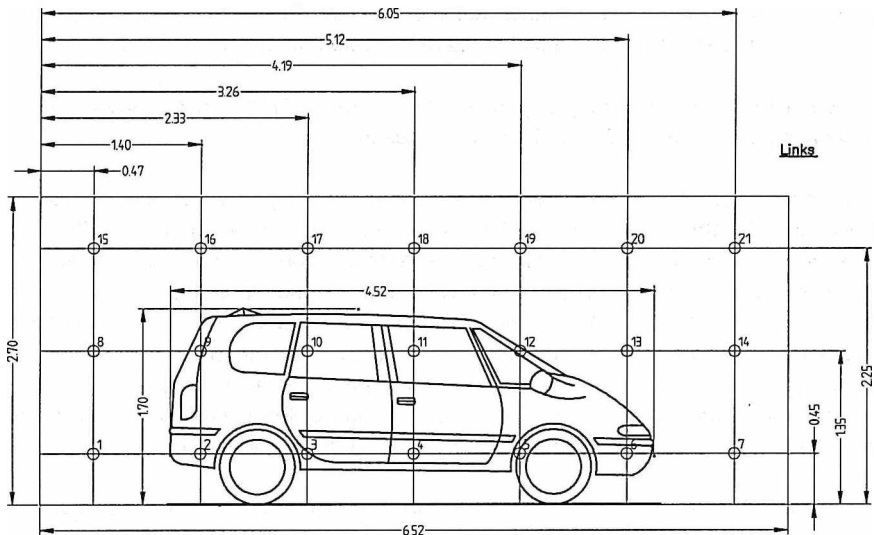

Fig. 6.1 Right side view with measuring points 1 to 21

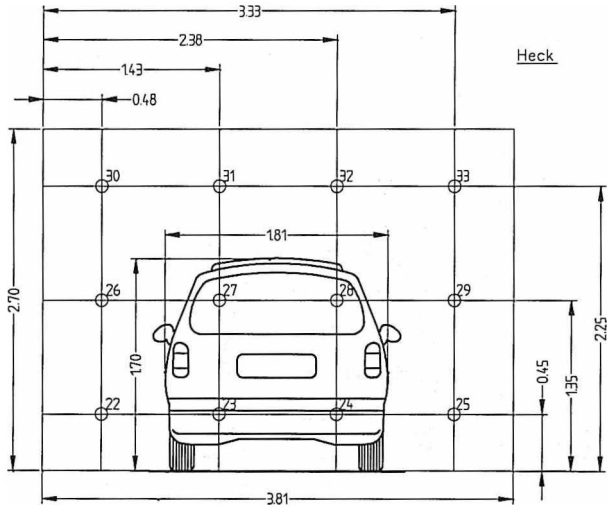

Fig. 6.2 Rear view with measuring points 22 to 33

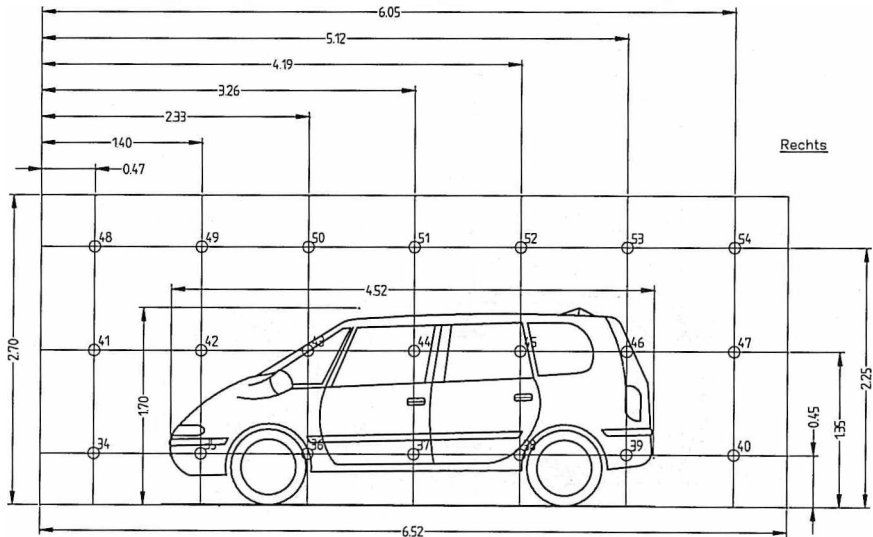

Fig. 6.3 Left side view with measuring points 34 to 54

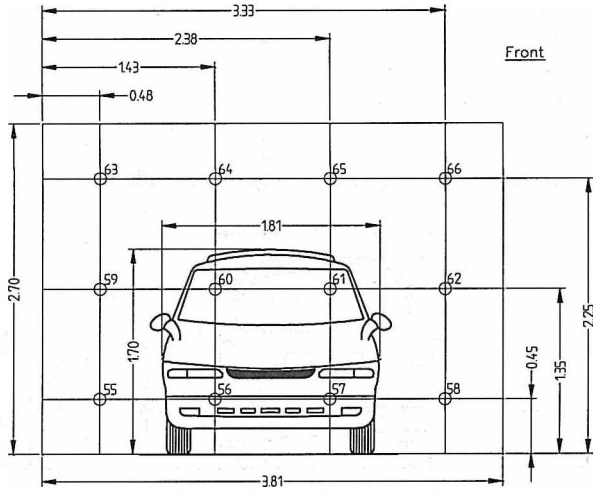

Fig. 6.4 Front view with measuring points 55 to 66

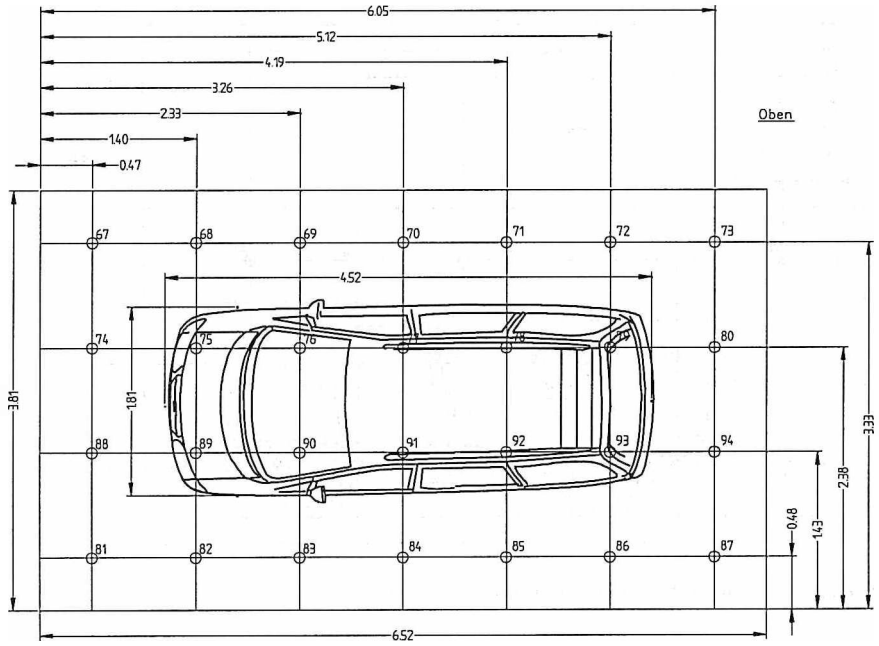

Fig. 6.5 Top view with measuring points 67 to 94

In condition „with directivity“ the left window at the drivers position is opened. By this the measuring points 43 and 44 are located in the maximum of the radiation (Fig. 6.3 with left side view).

The measurements have been carried out sequentially in one third octave bands with the following instrumentation:

- Gras intensity probe with 2 microphones ½ Zoll
- Two channel realtime-analyser Norsonic Type 840

6.3.2 The emission measured with free field conditions as reference

The reference values for the emission have been measured in free field on a reflecting concrete floor.

Tab. 6.1 and Fig. 6.6 show the sound power level in frequency bands for the two conditions „with directivity“ and „omnidirectional“. The emission in condition „omnidirectional“ has its maximum at low frequencies, because in this condition all windows of the car are closed and with transmission loss raising with frequency the higher frequencies are attenuated much more.

Tab. 6.1 Sound power level of the model-machine (measured with free field conditions)

frequency	sound power level (dB) radiation	
	omnidirectional	with directivity
100	85,7	87,5
125	88,2	90,7
160	87,6	89,1
200	84,0	87,2
250	87,2	93,6
315	83,1	86,5
400	79,4	86,1
500	79,3	85,5
630	76,2	83,9
800	72,7	80,7
1000	68,3	80,9
1250	67,3	81,7
1600	66,3	83,0
2000	67,4	84,3
2500	66,5	81,7
3150	64,7	75,1
4000	59,9	72,6
5000	53,2	67,7
lin	94,5	99,0
A	85,2	93,6

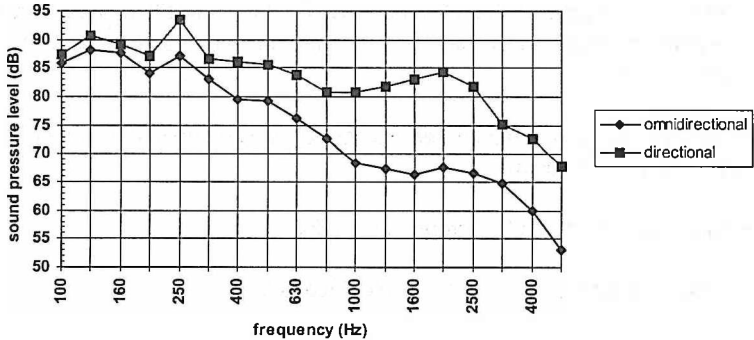

Fig. 6.6 Sound power level spectra in both conditions (upper curve - with directivity)

The influence of the open window can be seen by comparing the sound pressure levels at measuring points 44 and 45 for both conditions. The sound pressure level is 85.2 dB(A) with closed, 93.6 dB(A) with open window.

In the diagram Fig. 6.7 the sound pressure level is shown in dependence of the angular position. The angle at the horizontal scale is 0 in driving direction and positive counterclockwise, the height of the measuring points that have been used for this evaluation is 0.46 m above the reflecting floor.

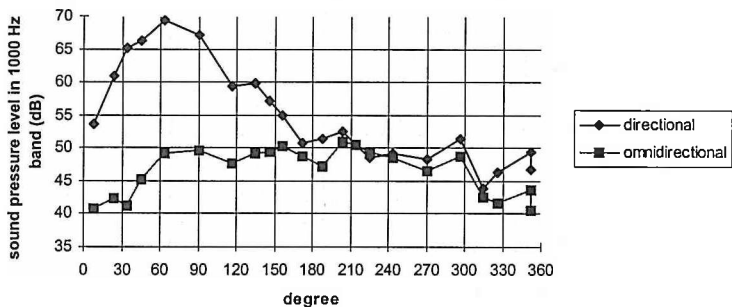

Fig. 6.7 The sound pressure levels in the 1000 Hz band in dependence of the angular position for the measuring path 0.46 m above floor

The diagram shows that even in condition „omnidirectional“ there are variations of about 10 dB in sound pressure levels. In condition „with directivity“ the levels in the

direction of maximal radiation are about 20 dB higher than the mean level for all directions.

With this examination in free field all reference data that are necessary have been acquired.

6.4 The measurements in halls

6.4.1 The acoustical properties of the halls

The halls chosen for this study should comprise a broad spectrum of acoustical properties with respect to a large variation of the environmental correction K_3 . As a correction according to ISO 11201 is only approved with nearly free field conditions - strictly speaking rooms with a K_2 of maximal 2 dB - and the other standards 11202 to 11205 can be used as well in halls with large room influence, 3 halls with $K_2 < 2$ dB und 3 halls with $K_2 > 2$ dB have been chosen.

In each hall the reverberation time as well as the sound decay curve have been measured in frequency bands according to VDI guideline 3760 and standard ISO/DIS 14257. Tab. 6.2 shows the most important results for all 6 halls. The presented values of excess level DL_f and level decay per doubling of distance DL_2 are related to the mean distance region source-receiver of 5 m to 16 m.

Tab. 6.2 The main figures to describe the acoustical properties of the 6 halls.

hall no.	length m	breadth m	height m	volume m ³	T60 s	A m ²	DL _f dB	DL ₂ dB	K_2 dB
1	116.0	30.0	8.0	27840.0	3.69	1229.8	7.8	2.4	1.0
2	156.0	58.0	13.3	120338.4	3.65	5369.1	7.5	3.7	0.3
3	212.0	25.0	9.3	49290.0	3.22	2497.7	7.6	2.6	0.5
4	55.0	25.0	4.3	5912.5	2.82	341.8	13.5	2.2	2.9
5	32.0	16.0	4.5	2304.0	3.14	119.6	13.5	2.6	5.7
6	13.0	12.0	4.5	702.0	1.53	74.7	13.4	0.4	7.3

Reverberation time T60 and equivalent absorption area A are related to the 1000 Hz band.

The environmental correction K_2 is determined with the measuring surface S of the model-machine of 82 m² and with the above-mentioned equivalent absorption area A from

$$K_2 = 10 \times \log\left(1 + \frac{4 \times S}{A}\right) \quad (6/1)$$

In Fig. 6.8 to Fig. 6.13 the sound decay curves according to ISO/DIS 14257, that have been measured in these 6 halls, are shown.

(The scale descriptions of these diagrams are in German language. The writing at the x-axis means „distance source - receiver“, at the y-axis „difference of sound pressure level and sound power level“).

The curves of the first three halls 1 to 3 show a nearly free-field behavior for distances source receiver smaller than 5 m. But this is only meaningful for omnidirectional radiating point sources and not, as is shown later, for big radiating objects with arbitrary directivity.

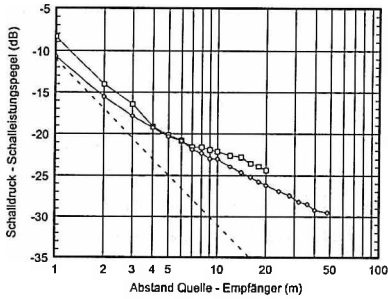

Fig. 6.8 Sound decay curve in hall 1

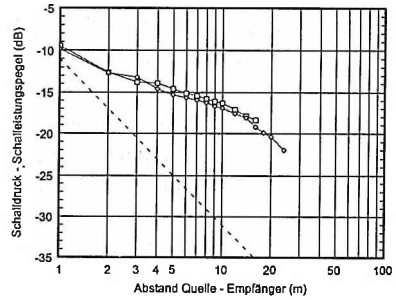

Fig. 6.11 Sound decay curve in hall 4

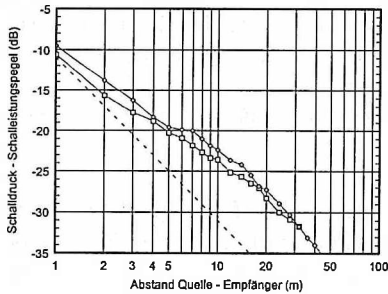

Fig. 6.9 Sound decay curve in hall 2

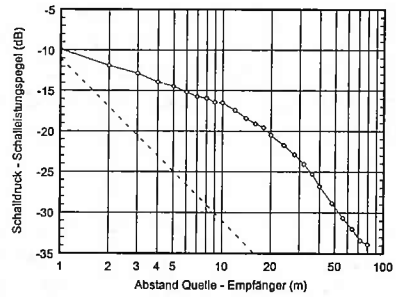

Fig. 6.12 Sound decay curve in hall 5

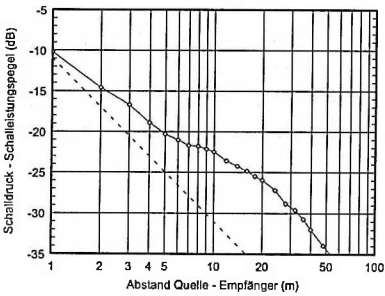

Fig. 6.10 Sound decay curve in hall 3

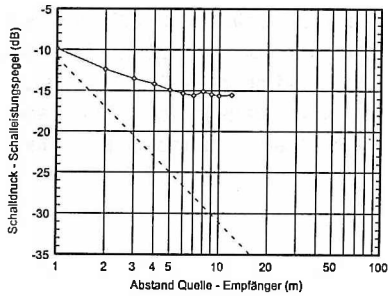

Fig. 6.13 Sound decay curve in hall 6

6.5 Measurements with the Model-machine and Determination of the Sound Power Level

In each of these 6 halls exactly the same measurements with the two conditions „with directivity“ and „omnidirectional“ have been carried out. While the source was operated in the car and produced this calibrated radiation, the sound pressure level and the sound intensity level was measured at all 94 measuring points in 1 m distance. All these sound pressure and sound intensity level spectra were saved for later processing.

The sound pressure level at the measuring points is increased by the sound field produced by reflections. Fig. 6.14 shows as an example with the same presentation as in Fig. 6.7 the sound pressure level in dependence of the angular position for a path in 0.41 m height around the car, but with the curves for the source with directivity in free field, in hall 1 with small room influence ($K_2 = 1$ dB) and in hall 5 with large room influence ($K_2 = 5.7$ dB). The difference of the curve measured in a hall to the free field curve (-- □ -- □ --) is the actual room influence at the regarded point.

Although for room 1 with its environmental correction K_2 of 1 dB and the sound decay curve Fig. 6.8 with shallow thinking a negligible increase of levels could be expected near the source, the measured levels in this hall (curve --Δ--Δ-- in Fig. 6.14) up from 180 degree show values about 7 dB for this room influence. For hall 5 this influence increases to 16 dB.

This diagram defines the task - it is necessary to find from measurements at a single point the correction K_3 , so that by subtracting it from the measured level the value on the free field curve is derived. It is clear that this correction cannot be a constant value, as the variation of the difference between the curves in figure 34 show. It is also clear that the correction is smallest at those points where the levels are highest.

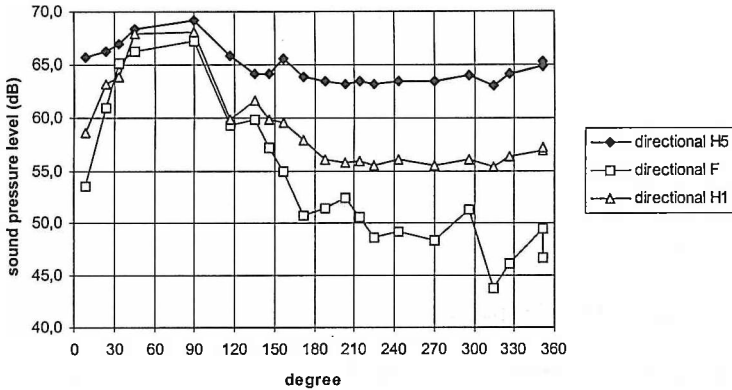

Fig. 6.14 The sound pressure levels in the 1000 Hz band in dependence of the angular position for the measuring path 0.46 m above floor, source radiating with directivity (---◆--- hall 5, ---△--- hall 1, ---□--- free field)

6.6 Examination of errors when using K3-corrections according to ISO 11200 series

6.6.1 Statistical Approach

To come to results in the sense of the tasks described in the scope each of the 94 measuring points one after the other is regarded as operators position. By applying the procedure under test for the correction from room influence for each frequency band and for the linear and A-weighted Level the corrected level and its deviation from the true value is determined. This gives a deviation for each of the 94 points for each of the two conditions and at least the mean value and the standard deviation of all these values.

It seemed not to be advantageous to average all these deviations for all halls.

Firstly the ISO 11201 procedure is not applicable for halls with K_2 larger than 2 dB. Secondly it makes sense to distinguish between halls where measurements can be made according to different accuracy classes, because different procedures can prove to be optimal for these two groups. Therefore the analysis has been carried out for the two groups hall 1 to 3 and hall 4 to 6 separately.

The diagram Fig. 6.14 shows, that the room influence at a specified point depends in fact on the value of the uncorrected level like it is assumed with the derivation of the ISO 11204 procedure.

The directivity index DI_j for the measuring point j is

$$DI_j = L_j - \bar{L} \quad (6/2)$$

with

$$\bar{L} = 10 \times \log \frac{1}{N} \sum_{j=1}^N 10^{0.1 \times L_j} \quad (6/3)$$

N number of measuring points

The described procedure to evaluate the K_3 correction is used with all standards of the ISO 11200 series.

6.6.2 The correction according to the ISO 11200 series.

With the following only the main content of the standards, that are important for this examination, shall be explained.

ISO 11201 don't use a correction for room influence. The authors presumably thought, the deviation of the so determined emission sound pressure level from the true value should be limited enough, because the application of this standard is restricted to an environment with K_2 not exceeding 2 dB. The related class of accuracy is 2.

In the course of this study the measured sound pressure levels therefore are used as emission sound pressure levels without any correction. The deviation of this measured level from the free field value is used directly in the statistical analysis. This standard is applied only for the halls of group 1 with K_2 not exceeding 2 dB.

ISO 11202 uses an environmental correction, that is constructed in a way, as if the total sound energy emitted by the machine would be radiated from the surface area which is nearest to the operators position. It is calculated with the same equation as it is used for the calculation of K_2

$$K_2 = 10 \times \log \left(1 + \frac{4 \times S}{A} \right) \quad (6/4)$$

with area S determined from

$$S = 2 \times \pi \times a^2 \quad (6/5)$$

where a is the measuring distance used. If this procedure gives a value exceeding 2.5 dB, the actual correction is

$$K_3 = 2.5 \text{ dB} \quad (6/6)$$

With this technique from all possible source distributions on the surface of the machine that one is assumed, that leads to the smallest correction K_3 . Presumably it was the intention of the authors, to use with all the unknown facts about source distribution a model that is on the safe side (it must be mentioned that it's the safe side for the machine user and the unsafe side for the machine supplier, if the consequence of the declaration or of contracts is taken into account).

This method according to ISO 11202 is applicable for rooms with K_{2A} of maximal 7 dB (K_{2A} is the correction related to the A-weighted sound pressure level). In ISO 11202 it is related to the accuracy class 3.

With this study all 3 criteria are taken into account. With a measuring distance of 1 m K_3 is calculated with

$$K_3 = 10 \times \log\left(1 + \frac{25}{A}\right) \quad (6/7)$$

If this gives a result more than 2.5, the determined correction is

$$K_3 = 2.5 \quad (6/8)$$

The procedure is applied to both groups of halls, because the K_{2A} value doesn't exceed 7 dB by an essential amount (Only for hall 6 this value is 7.3 dB).

ISO 11203 is not used in this examination. With this standard a constant difference between sound power level and emission sound pressure level is assumed and therefore the latter is derived from the first by subtracting a constant that should be defined machine specific for a given machine family. It may be advantageous for little, hand held machines, but it is also clear that it must be inaccurate, if the directivity varies and if this difference is not examined and published for use. This standard is further restricted in use for machines with dimensions smaller than 1 m. The application with the model-machine is not acceptable

ISO 11204 describes a method, that has been developed and proposed by the author. In a certain sense it is not „new“, but a consequent continuation of the K_2 -procedure, but without any assumptions about source distribution, position of

regarded workplace and directivity of the radiation. All these influences are included in the definition of the correction with

$$K_{3j} = -10 \times \log \left[1 - \frac{1}{1 + \frac{A}{4 \times S}} \times 10^{-0.1 \times (L_j - \bar{L})} \right] \quad (6/9)$$

with

L'_j uncorrected measured sound pressure level at point j
 \bar{L} energetic mean value of the uncorrected sound pressure levels on a measuring surface.

With the existing draft of the standard the application of ISO 11204 is restricted to rooms where the so determined correction K_3 does not exceed 7 dB. The accuracy class in this cases is 2.

With this examination the described technique is used without any restrictions. It shall be noted that the difference of the measured sound pressure level and the true value measured at the same point in free field is about 25 dB at the points opposite to the open window (main radiation direction) in the condition „with directivity“. This is often the case in reality if the machine body is not acoustically transparent and the main sources are opposite to the operators position.

With this study a correction K_3 of 7 dB is assumed in all cases, where the value calculated from (6/9) exceeds 7 dB. The limit of 7 dB is therefore used in the same way as it was the case in ISO 11202 with the limit of 2.5 dB.

ISO 11205 didn't exist as an official draft at the time this work was done. It was only clear that a standard was in preparation, that uses the sound intensity level directly to determine the value of the emission sound pressure level. The assumption is, that the sound field caused by reflections at the room surfaces and at other reflecting objects will compensate completely when measuring with the intensity probe.

It is also used in this study without any restriction. The deviation used in the statistical analysis is the difference of the sound intensity level measured at the regarded point in the hall and the equivalent sound pressure level measured in free field conditions.

Differing from the later published procedure, the intensity probe was oriented always normal to the assumed surface of the radiating object. (An additional examination with the later published three axes method is described later).

6.7 Summary - results of the analysis

From the results each single deviation for each of the examined procedures can be seen (each deviation in each of the 6 halls for each of the two conditions at each of 94 measuring points, if necessary for each frequency band and for linear and A-weighted levels). With these data all single results can be reproduced.

The accuracy that is associated with the different procedures can be evaluated by comparing the mean value and the standard deviation of all the deviations for all 94 points and for the 3 halls of a group and one condition.

The analysis related to the A-weighted emission-sound-pressure-level is shown for the first group of halls with $K_2 < 2$ dB in Tab. 6.3, for the second group of halls with $K_2 > 2$ in Tab. 6.4.

Tab. 6.3 Total analysis for rooms with $K_2 < 2$ dB (hall 1, 2, 3)
Procedure according to ISO 11201 to ISO 11205
m mean value, s standard deviation of errors in dB

ISO	radiation	1		2		3		all	
		m	s	m	s	m	s	m	s
201	omnidirect.	1,5	0,9	1,3	0,8	1,2	0,8	1,3	0,8
202	omnidirect.	1,5	0,9	1,3	0,8	1,2	0,8	1,3	0,8
204	omnidirect.	0,3	0,8	1,0	0,7	0,6	0,7	0,6	0,8
205	omnidirect.	-1,6	1,0	-1,8	0,9	-2,1	1,1	-1,8	1,0
201	directional	2,7	1,6	2,2	1,6	2,3	1,7	2,4	1,6
202	directional	2,6	1,6	2,1	1,6	2,3	1,7	2,3	1,6
204	directional	-0,4	1,5	1,6	1,3	0,9	1,4	0,7	1,6
205	directional	-1,5	1,4	-1,9	1,7	-2,1	2,0	-1,8	1,7

Tab. 6.4 Total analysis for rooms with $K_2 > 2$ dB (hall 3, 4, 5)
 Procedure according to ISO 11201 to ISO 11205
 m mean value s standard deviation of errors in dB

ISO 11	radiation	4		5		6		all	
		m	s	m	s	m	s	m	s
202	omnidirect.	4,4	1,9	4,9	1,5	2,8	1,3	4,1	1,8
204	omnidirect.	1,3	2,5	-0,5	1,3	-2,7	1,2	-0,6	2,4
205	omnidirect.	-3,0	3,4	-2,9	3,7	-2,9	1,7	-2,9	3,1
202	directional	6,7	3,4	7,3	3,3	6,3	3,3	6,8	3,3
204	directional	2,3	3,1	1,9	2,0	0,8	2,3	1,7	2,6
205	directional	-2,7	6,4	-2,1	4,9	-3,4	5,2	-2,7	5,5

The mean value m of the errors shows the systematic, the standard deviation s the random deviation of the so determined emission sound pressure levels. As a one number rating for the accuracy of a certain procedure may be used the sum of the weighted absolute values according to

$$f = |m| + |0.5s| \quad (6/10)$$

This value is approximately (strictly speaking with normal distributed deviations) the error, that is exceeded with about 30 % of all determinations of the emission sound pressure level. An exceeding in this sense is given with positive or negative deviations.

Tab. 6.5 Error f in dB as one number rating of the results

ISO	halls with K_2			
	< 2 dB		> 2 dB	
	omnidirect.	directional	omnidirect.	directional
11201	1,7	3,2		
11202	1,7	3,1	5,0	8,2
11204	1,0	1,5	1,8	3,0
11205	2,3	2,6	4,4	5,4

ISO 11201 leads to an error that is directly the increase in sound pressure level that is caused by the room, because no correction is used. This error can be large in spite of the limitation of the method to halls with $K_2 < 2$ dB, if the working place is located in a region with minimum radiation.

The difference of the mean curve related to hall 1 in figure 20 and the free field curve is directly the error when using ISO 11201 - accuracy class 2 is not reached for most points.

The error exceeded in 30 % of all cases is in spite of the small overall room influence 1.7 dB with omnidirectional radiation, 3.2 dB with directional radiation.

ISO 11202 leads to a value of 1.7 dB with omnidirectional and 3.1 dB with directional radiation for this 30% error with halls group 1. It is therefore comparable to ISO 11201 for this halls. More problematic is the use in halls of group 2 with large room influence - the 30 % error is in this case 5.0 dB with omnidirectional, 8.2 dB with directional radiation. This can be dangerous for a machine producer, who declares the emission sound pressure level for an operators position that is protected against the direct radiation from the machine by a screen, that has been measured in free field conditions, if the measurement after installation in a hall with low absorption is carried out with ISO 11202.

ISO 11204 gives the best accuracy with these conditions. Even though the used statistic theory that is the basis of this correction is only a rough approximation in many cases it can be stated, that the so determined correction follows the tendency clearly seen in Fig. 6.14 - it is small in regions of high radiation and large where the radiation is low. These results show, that the dependence between correction and directivity and sound power level, that is clearly seen in the derivation of the 11204-correction formula, can not be neglected.

With the halls of group 1 the 30%-error is 1.0 dB with omnidirectional, 1.5 dB with directional radiation. With group 2 of halls with low absorption this error is 1.8 dB with omnidirectional, 3.0 with directional radiation.

The used approximation, that for K3 the maximum is 7 dB, even if the calculation gives a higher value, has proved to be advantageous.

ISO 11205 and the direct use of sound intensity levels, that have been measured with intensity probe vertical to the measuring surface, lead to emission sound pressure levels that are systematically too low. The 30 % error with halls of group 1 is 2.3 dB with omnidirectional, 2.6 dB with directional radiation. With halls of group 2 this error is 4.4 dB with omnidirectional, 5.4 dB with directional radiation.

The procedure is based on the assumption, that the sound field caused by the room gives no contribution to the sound-intensity, is it is diffuse enough. Measurements of the sound intensity level far away from the sources show, that this is not the case. But even with a completely diffuse sound field or even in free field the minimum error is the discussed angle error, because even in the direct sound field a difference between sound pressure and sound intensity level is caused because the rays fall with different angles on the intensity probe (this all is related to a vertical positioning of the probe relative to the measurement surface).

6.8 Measurement of the sound intensity level in three axes (ISO 11205 - 1997)

The Draft 1997 of ISO 11205 recommends to measure the intensity in three directions that are perpendicular to one another and to calculate from this the maximal intensity flow - its value is used as approximation for the emission sound pressure level. With some additional measurements the accuracy related with this method was examined.

The car used as a model machine was again brought to halls 3, 4 and 6 - the other halls couldn't be used again. The emission sound pressure level was determined for all measuring points of the path with height 1.35 m around the source using the 3-axes intensity method.

The Fig. 6.15 to Fig. 6.20 show the results of this examination. The same evaluation and diagram presentation is used for ISO 11204 and ISO 11205, so that these two techniques can be easily compared. Each point in a diagram is the result of the evaluation if one point of this path is regarded as operators position. The deviation of the so determined emission sound pressure level from the „true“ value is plotted in dependance from the directivity index of this point.

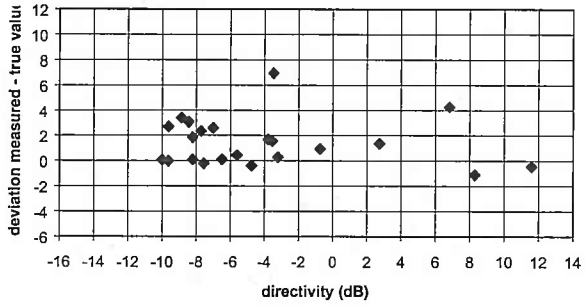

Fig. 6.15 Evaluation on measuring path according to ISO 11204, hall 3, A-weighted level, radiation directional

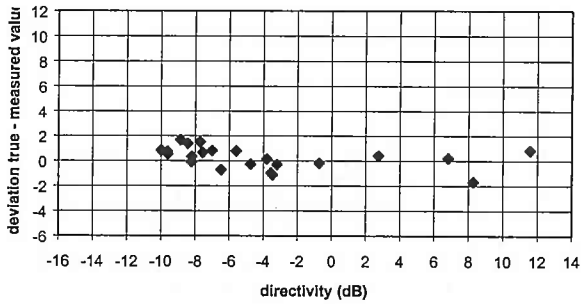

Fig. 6.16 Evaluation on measuring path according to ISO 11205, hall 3, A-weighted level, radiation directional

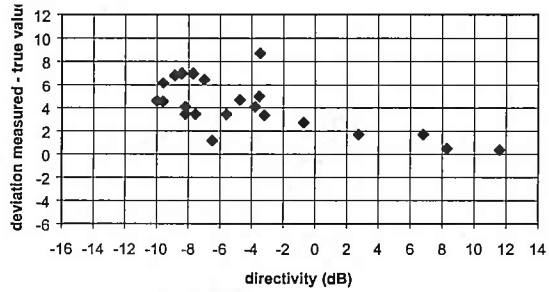

Fig. 6.17 Evaluation on measuring path according to ISO 11204, hall 4, A-weighted level, radiation directional

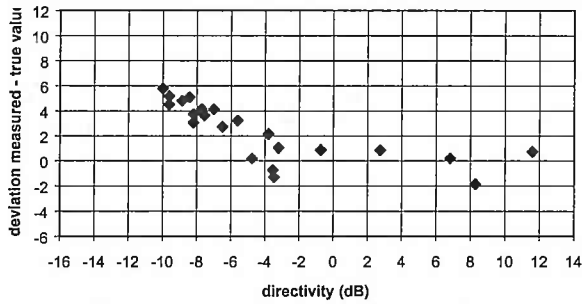

Fig. 6.18 Evaluation on measuring path according to ISO 11205, hall 4, A-weighted level, radiation directional

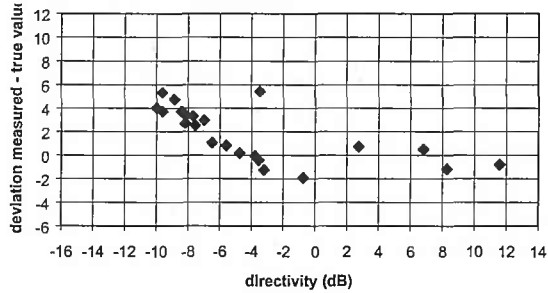

Fig. 6.19 Evaluation on measuring path according to ISO 11204, hall 6, A-weighted level, radiation directional

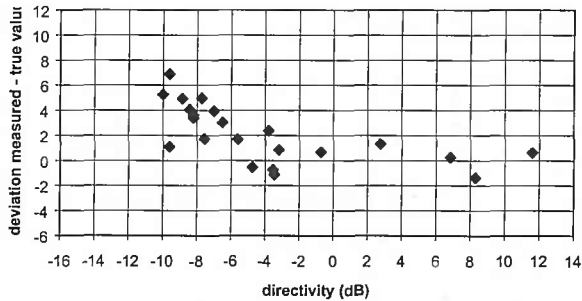

Fig. 6.20 Evaluation on measuring path according to ISO 11205, hall 6, A-weighted level, radiation directional

A final valuation is difficult, because the basis with these 3 halls is too small to come to final decisions about the accuracy of the method. But a common tendency can be seen for ISO 11204 and ISO 11205 - the deviations are small in areas with positive directivity index and scatter around zero, while they grow rapidly with more negative directivity index.

With these three halls the deviations related to A-weighted levels are smaller when using ISO 11205 than ISO 11204.

In Fig. 6.22 to Fig. 6.27 the deviations when using ISO 11205 are shown for each measuring point. For this evaluation the A-weighted level with relation to a mean spectrum typical for industrial sources have been used. Fig. 6.21 shows the used symbols.

⊕	$0 \text{ dB(A)} \leq \Delta L < 2 \text{ dB(A)}$
⊕	$2 \text{ dB(A)} \leq \Delta L < 4 \text{ dB(A)}$
⊕	$4 \text{ dB(A)} \leq \Delta L < 6 \text{ dB(A)}$
●	$6 \text{ dB(A)} \leq \Delta L < 8 \text{ dB(A)}$
●	$8 \text{ dB(A)} \leq \Delta L < 10 \text{ dB(A)}$

Fig. 6.21 Symbols to describe the deviations in Fig. 6.22 to Fig. 6.27

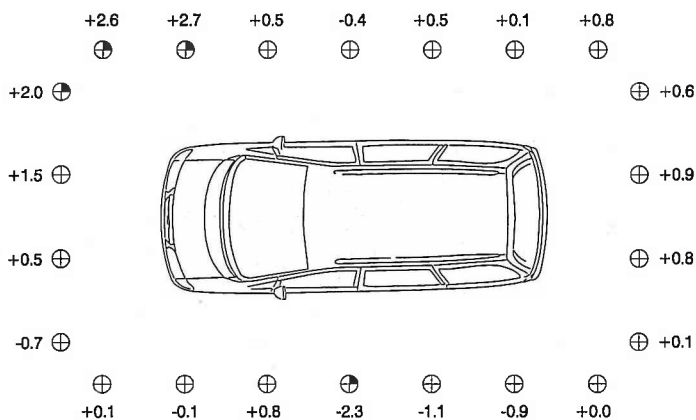

Fig. 6.22 Deviations with ISO 11205 for total level (related to spectrum for industrial sources), hall 3, radiation directional

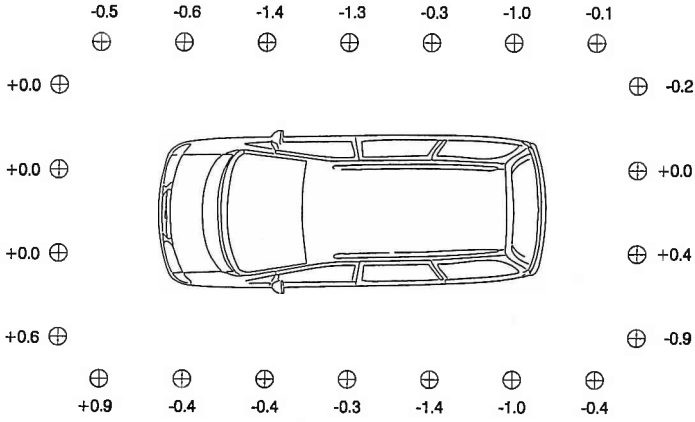

Fig. 6.23 Deviations with ISO 11205 for total level (related to spectrum for industrial sources), hall 3, radiation omnidirectional

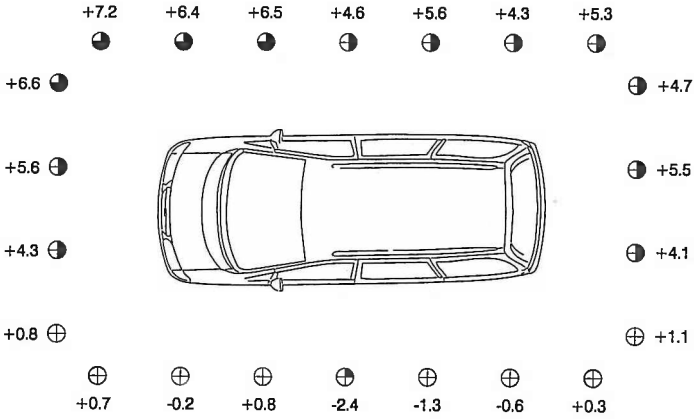

Fig. 6.24 Deviations with ISO 11205 for total level (related to spectrum for industrial sources), hall 4, radiation directional

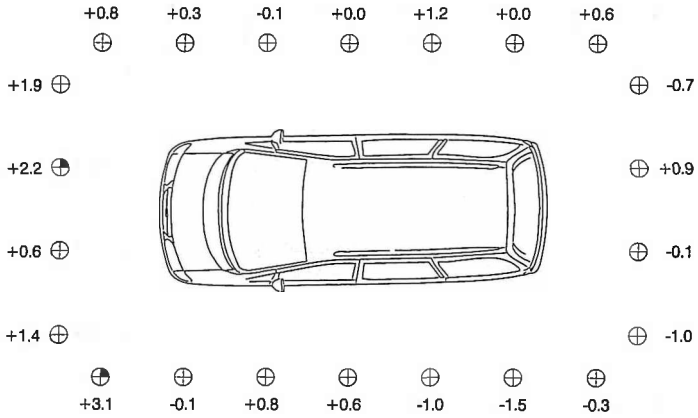

Fig. 6.25 Deviations with ISO 11205 for total level (related to spectrum for industrial sources), hall 4, radiation omnidirectional

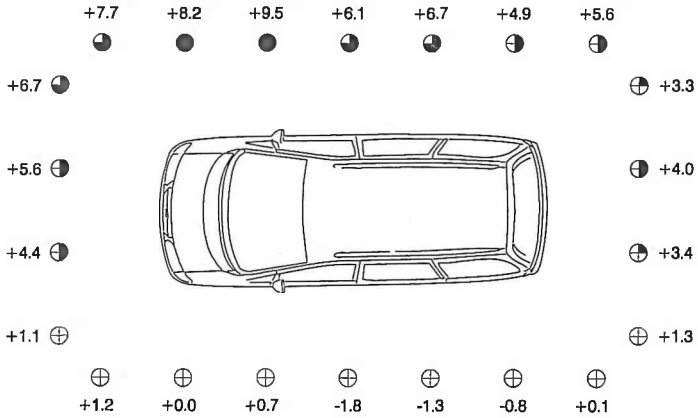

Fig. 6.26 Deviations with ISO 11205 for total level (related to spectrum for industrial sources), hall 6, radiation directional

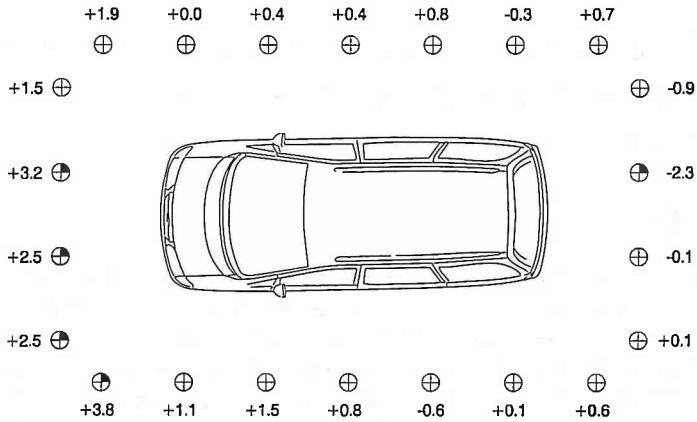

Fig. 6.27 Deviations with ISO 11205 for total level (related to spectrum for industrial sources), hall 6, radiation omnidirectional

The deviations are largest with directional radiation, where the receiver point is positioned in more „silent“ areas with negative directivity. Nevertheless the change from intensity measurement in one probe-direction to a three axes measurement has given a much better accuracy. The price for this improvement is a more complicated and time consuming procedure.

7 Examination regarding the accuracy of the standard draft ISO 3747 for the determination of the sound power level.

7.1 Scope

In ISO 3747 a measurement procedure is described, which can be used with the machine operating in its typical industrial environment and that allows the determination of the sound power level with a number of measuring points that is small in relation to the sound pressure enveloping surface method according to ISO 3744 or ISO 3746. The principle of the method is the comparison of the sound pressure levels in the hall, if the machine under test (ST - source under test) on one side and of a reference sound source (RSS - Reference Sound Source) on the other side are in operation. This method has been treated in /17/, /18/ and /19/.

With the enveloping surface method the direct sound field is used to determine the emission and so the contributions that are caused by reflections from hall and other surfaces have to be eliminated with corrections (K_2 , K_3). With the comparison method according to ISO 3747 similar to ISO 3741 the sound field caused by reflections from room and other surfaces is used. With a large enough measuring distance it is ensured that the contribution of the direct sound field is low enough.

While ISO 3741 presupposes the validity of the diffuse field conditions between the sound power level of the source and the sound pressure level in the room, therefore needs strong requirements with respect to the acoustic properties of the room and can only be used in special laboratory-conditions, these requirements are much weaker and can be fulfilled in usual industrial halls with ISO 3747.

These requirements are the reason for long lasting discussions in the responsible standardization working groups and it is indeed unsatisfactory to decide about such requirements without sufficient knowledge about the relation between the parameters describing the measurement environment and the accuracy of the determined emission level.

It was a goal of this examination to reduce this deficit and to contribute a little bit to the knowledge about these relations.

It was intended to give answers to the following questions:

- What are the requirements with respect to the absorption of the halls

- Is it necessary and sufficient to define a requirement on behalf of a minimal DLF like it is the case in the existing draft of ISO 3747?
- Are there relations between the position of RSS, microphone and the accuracy of determination ?
- How is the accuracy influenced by number of RSS- and microphone positions?

7.2 Description of the procedure

The method of this examination is the same as used to check the accuracy of the ISO 11200 series. A dodecahedron-loudspeaker was installed in a van - in this case a Renault Espace was used - and fed with broad band noise signal. The backseats were removed for that purpose. Again the directivity for two conditions was controlled by the open or closed window at the left side of the drivers position. The free field emission was measured with the envelopping surface method and measuring distance 1 m with

- Sound intensity method with fixed measuring points according to ISO 9614 part 1
- Sound Intensity method with scanning according to ISO 9614 part 2
- Sound pressure method according to ISO 3744.

The car was brought into 6 different halls and in each of these halls measurements according to the existing draft of ISO 3747 have been carried out. With each of these measurement arrangements so many RSS and microphone positions were used, that in the evaluation process later all discussed criteria and requirements could be fulfilled as well as hurried.

Measurements have been made for the two conditions „radiation omnidirectional“ and „radiation directional“. These measurements have been carried out with Real-Time-Analyser Norsonic Type 840. At each measuring point a frequency spectrum in one third octave band is saved for both conditions directional and omnidirectional radiation of the car and with the reference sound source radiating in 6 different positions located on the surface of the car. The octave band levels are calculated from the third octave band levels in the evaluation process. In each hall the reverberation time and the sound decay curve was measured in octave bands.

For the evaluation with different strategies software programs have been developed, that use the saved spectra, calculate the sound power level in accordance to ISO 3747 and the differences between these results and the „true“ values from free field measurements. This process is repeated with different

statistically controlled choices of measuring points and also the results are „compressed“ by statistical methods. All calculations are carried out in frequency bands, with total levels calculated from frequency band levels and with the originally measured total levels. In some halls special examinations with respect to the influence of the source position (far from walls, at a wall or in an edge), the fitting density and the height of the microphone positions relative to fitting height were additionally included.

7.3 The vehicle as model machine

7.3.1 The measurement setup

The dimensions of the car are nearly identical with those of the Ford Galaxy used for the ISO 11200 examination. The descriptions of the car with measuring points and source installation is therefore identical..

7.3.2 The emission measured with free field conditions as reference

The reference values for the emission have been measured again in free field on a reflecting concrete floor. The sound pressure and the sound intensity spectra have been measured at the measuring points on the envelopping surface in 1 m distance. Additionally the measurement technique of scanning was used when measuring the sound intensity.

For further evaluation the measurement of sound intensity with fixed measuring points according to ISO 9614 part 1 was used as reference. The difference of results gained with ISO 9614 part 1 and part 2 is some tenth of a dB.

The sound power level of the reference sound source (RSS) was determined in a reverberation chamber according to ISO 3741.

Tab. 7.1 shows the sound power level in frequency bands for the two conditions „omnidirectional“ and „directional“ of the model machine and of the reference sound source. The emission in the case „omnidirectional“ contains more sound at low frequencies, because the transmission loss of the car increases with frequency (Fig. 7.1).

The levels in frequency band 8000 Hz are shown in all these tables for reasons of the used software, although they are not included in the final evaluation. It should be noted that the distance between the microphones of the intensity probe excludes the use of this band.

Tab. 7.1 Sound power level of model machine and reference sound source

frequency (Hz)	sound power level of source		
	radiation of model machine		reference sound source
	omnidirectional	directional	
125	91,0	93,7	109,5
250	89,7	96,4	111,0
500	79,6	88,4	105,5
1000	71,0	82,9	101,9
2000	67,3	83,1	103,5
4000	58,8	73,8	96,7
8000	48,8	67,3	92,3

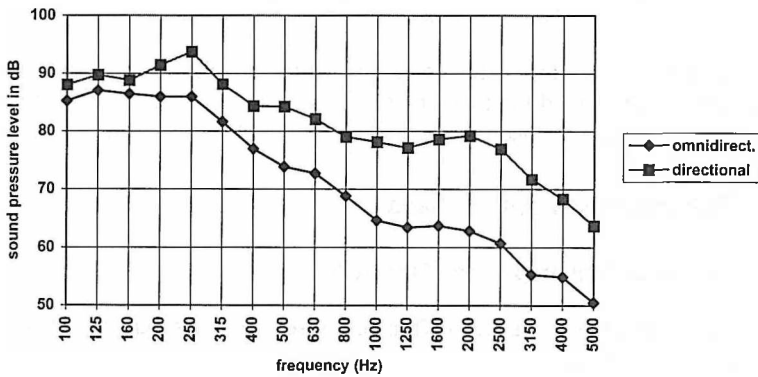

Fig. 7.1 The unweighted frequency spectra of the sound emission

Fig. 7.2 shows the sound pressure levels for the 1000 Hz band determined in free field for the points of the measuring path in 0.46 m height above floor in dependence of the angular position. This angle is related to the driving direction of the car.

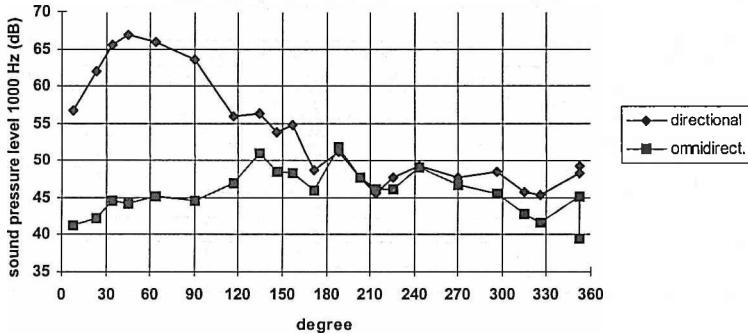

Fig. 7.2 Sound pressure levels in 1000 Hz band for the measuring path in 0.46 m height in dependence of the angular position.

The diagram shows, that the sound pressure levels differ even in case „omnidirectional“ about 5 dB from the mean value. In condition „directional“ the levels in the direction of main radiation are about 20 dB larger than the mean value.

7.4 The measurements in halls

7.4.1 The acoustical properties of the halls

Six halls were included in this study. Three of these halls have also been used in the ISO 11200-examination.

In each hall the reverberation time and the sound decay curve were determined in frequency bands. Tab. 7.2 shows the main results of these measurements.

Tab. 7.2 The most important one number values that characterize the 6 halls

hall	length m	breidth m	height m	volume m ³	T60 s	A m ²	DLf dB	DL2 dB	K ₂ dB
PK	55.0	25.0	4.3	5912.5	2.45	393.4	11.7	2.7	2.6
PL	212.0	25.0	9.3	49290.0	3.26	2464.5	7.4	2.3	0.5
RH	13.0	12.0	4.5	702.0	1.80	63.6	13.7	1.0	7.9
DO	82.5	71.0	6.1	35730.8	4.26	1367.2	7.0	2.8	0.9
DU	82.5	18.7	4.8	7389.4	2.11	570.8	11.8	2.3	2.0
GU	26.0	14.5	9.3	3487.3	1.86	305.6	10.0	1.6	3.1

Reverberation time T60 and absorption area A are for the 1000 Hz band. The environmental correction K₂ is related to the measurement surface of the model machine.

In figures 47 to 52 the sound decay curves for this 6 halls are shown. The given values of DLf and DL2 are related to the distance interval of 5 m to 16 m according to the VDI guideline 3760 and ISO 14257 (ISO/DIS 14 257 „Acoustics - Measurement and modelling of spatial sound distribution curves in workrooms for evaluation of their acoustical performance“)

(The scale descriptions of these diagrams are in german language. The writing at the x-axes means „distance source - receiver“, at the y-axis „difference of sound pressure level and sound power level“).

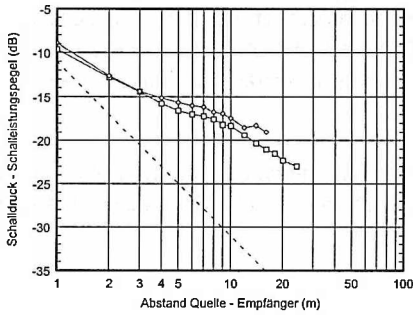

Fig. 7.3 Room PK - Dif = 11.7 dB - DL2 = 2.7 dB

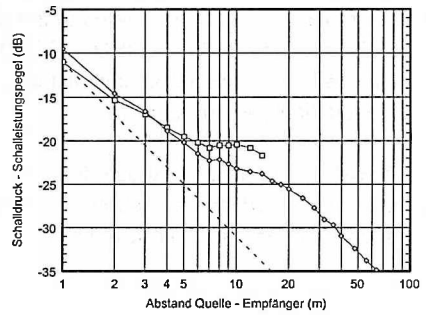

Fig. 7.4 Room PL - Dif = 7.4 dB - DL2 = 2.3 dB

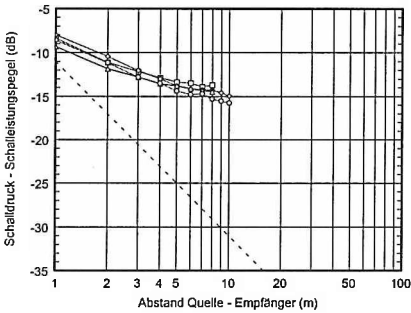

Fig. 7.5 Room RH - Dif = 13.7 dB - DL2 = 1.0 dB

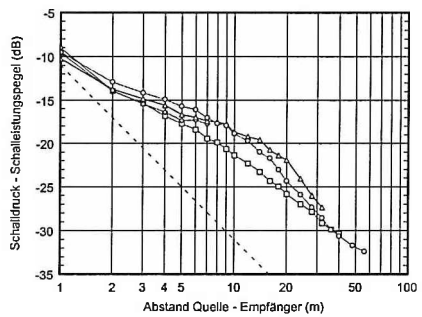

Fig. 7.6 Room DU - Dif = 11.8 dB - DL2 = 2.3 dB (ref)
Dif = 9.3 dB - DL2 = 3.9 dB (abs)

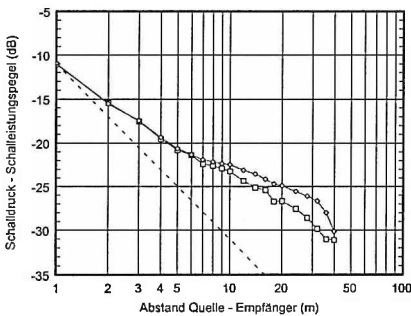

Fig. 7.7 Room DO - Dif = 7.0 dB - DL2 = 2.8 dB (length)
Dif = 7.7 dB - DL2 = 1.9 dB (breadth)

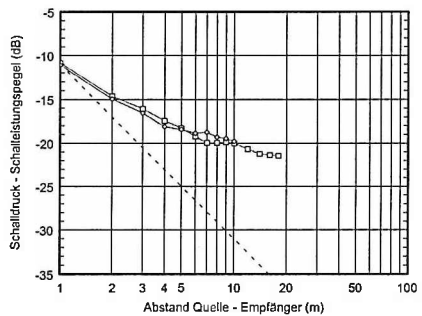

Fig. 7.8 Room GU - Dif = 10.0 dB - DL2 = 1.6 dB

7.4.2 Measurements with the model machine and determination of the sound power level

In each of these 6 halls measurements according to ISO 3747 for the two conditions „omnidirectional“ and „directional“ have been carried out.

In Fig. 7.9 the measuring positions and the position and orientation of the car used as model machine is shown for each hall. It shows also the measuring paths and the areas that are treated with absorption (hatched).

In hall DO three complete measurements were made with positioning the car in the middle of the hall, at the wall and in an edge.

In the little hall RH - it's normally used for the repair of cars - the complete measurement was made twice with different fitting density. The measurements with large fitting density were carried out with a microphone height that exceeds the height of the diffracting objects (other cars).

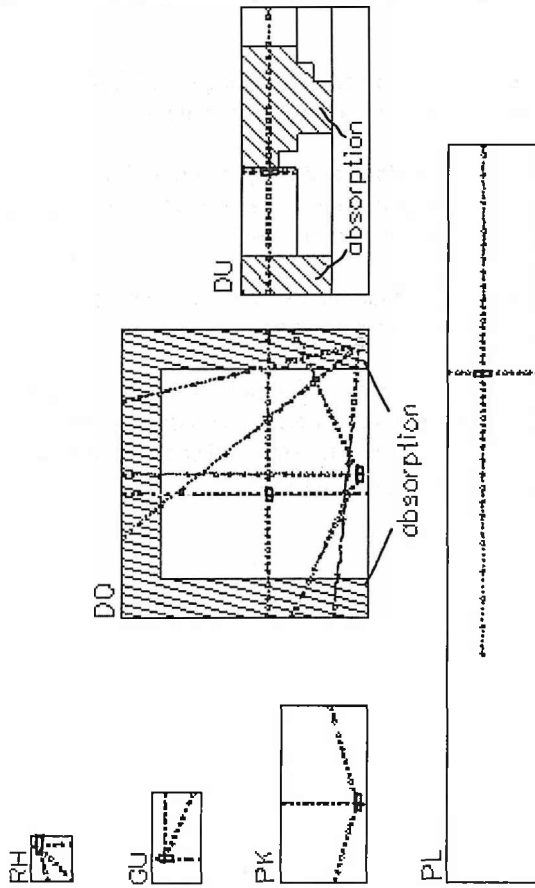

Fig. 7.9 Layout of measurement setup (source and paths) for the 6 halls

Fig. 7.10 shows the positions of RSS (dodekahedron) and measuring paths.

RSS-position d1 is on top, positions d2 to d5 in front of the sides of the car. Position d6 is used additionally with the model machine in condition „directional” - it is located in front of the window, that is opened to produce this directivity (with d6 radiating this window is closed).

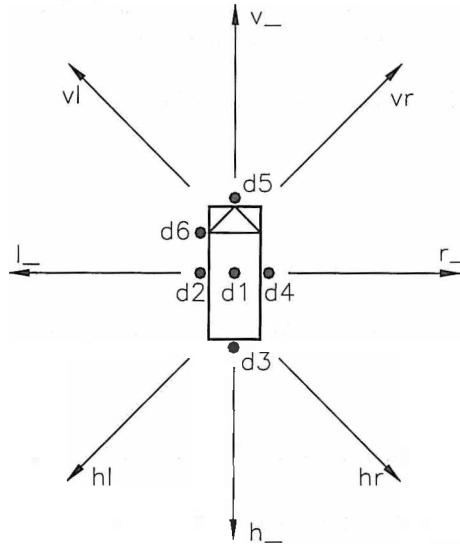

Fig. 7.10 RSS-positions d1 to d6 and the 8 measuring paths

For each measuring setup the following standard procedure was undertaken:

- positioning of the microphone
- measurement with model machine operating in condition „omnidirectional” with windows closed
- measurement with model machine operating in condition „directional” with windows open
- One measurement for each RSS-position with RSS operating.
- positioning of the microphone at the next position.

7.5 Evaluation and results

7.5.1 The method of evaluation

For evaluation software programs were developed, that allow to integrate free defineable sets of measurements or saved spectra in the determination of the sound power level. By this the deviations, that are the consequence of a certain choice or the hurting of normative requirements can be determined. It is also possible to study the influence of different positions of the source or of the reference sound source.

The first requirement is related to the minimum distance of the measuring points from the model machine:

$$d_m \geq 0.3 \times V^{1/3} \quad (7/1)$$

(d_m distance in m, V volume of the room in m^3)

The second condition requires a position of the measuring points with

$$DL_f \geq 10 \text{ dB} \quad (7/2)$$

(DL_f is the level excess at a point in dB relative to free field propagation)

To check this in all the halls a mean sound decay curve and from this the minimum distance with (7/2) fulfilled was determined. This showed that requirement (7/2) used for each frequency band separately gives nearest measuring points that differ maximal by one position on the measuring path. Therefore the nearest measuring point that doesn't hurt the requirement (7/2) was defined for each hall.

As an example Fig. 7.11 to Fig. 7.14 show the sound decay curves for some octave bands with the axis of hall PL as measuring path.

(The scale descriptions of these diagrams are in german language. The writing at the x-axes means „distance source - receiver“, at the y-axis „difference of sound pressure level and sound power level“).

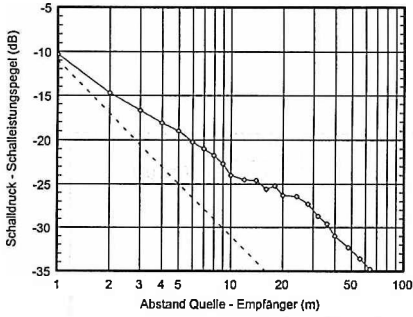

Fig. 7.11 Room PL - 500 Hz - Dif = 7.5 dB

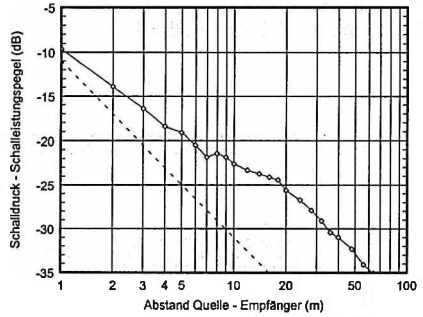

Fig. 7.12 Room PL - 1000 Hz - Dif = 8.0 dB

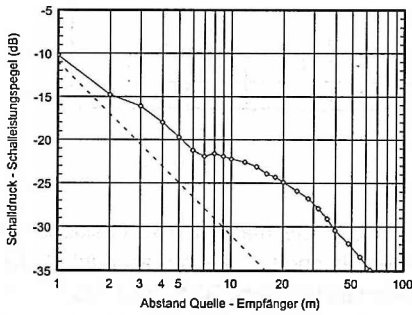

Fig. 7.13 Room PL - 2000 Hz - Dif = 8.0 dB

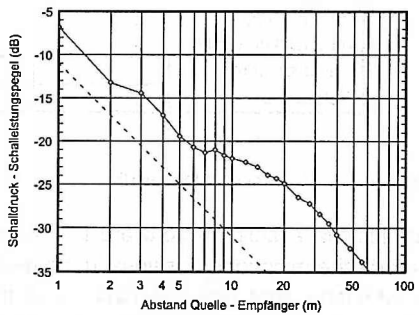

Fig. 7.14 Room PL - 4000 Hz - Dif = 8.4 dB

The spread-sheet instruction data for the control of the evaluation program are shown in Fig. 7.15 for hall PK.

		radiation			omnidirectional		directional		fz		
									fo	fo	actual
hall		l	b	h	V	0.3*(V ^{1/3})					
PK		55,0	25,0	4,3	5912,5	5,4					
position RSS		d1	d2	d3	d4	d5	d6				
		x			x	x					
position of paths		v_	vr	r_	hr	h_	hi	l_	v		
points till		12				10		10			
Krit.1 (V) hurted till		2				2		2			
Krit.2 (Dlf) hurted till		3				3		3			
Evaluation from		4				4		4			
Evaluation to		6				6		6	BSP_FRM.3		

Fig. 7.15 Control data for hall PK

By this the evaluation software is instructed to use the marked RSS-positions, to include the microphone positions in the given intervals and to take into account all the other informations given with this sheet. In the case shown the RSS positions d1, d4 and d5 and the measuring points 4 to 6 on the paths v_, h_ and l_ are included in the evaluation.

The following strategies for the evaluation are applied::

- **Evaluation for single points**

The octave band - sound power levels are determined **separately** for each combination RSS-measuring point and the deviation from the true value, that has been determined in free field with intensity method, is calculated as point related deviation. With example figure 56 this gives 27 evaluations for the condition „directional“ with 3 RSS- and 9 measuring positions.

- **Evaluation for domains**

In this case **all** RSS positions and measuring points defined in the control sheet (figure 56) are included in **one** determination of the sound power level.

- **Randomly controlled evaluation**

For the determination of the sound power level in octave bands

- all defined RSS-positions and
- for each selected path one measuring point, that is chosen from the defined intervall by control of a random generator

are used.

This procedure is repeated $2n$ -times, where n is the number of measuring points in the defined intervals.

The deviations are determined in frequency bands 125 Hz to 5000 Hz. From these the deviations related to the A-weighted sound power level of the model machine and additionally for a typical emission-spectrum of industrial sources is calculated. The latter may be helpful because the emission spectrum of the model machine is dominated by low frequencies.

Tab. 7.3 A-weighted „industry-spectrum“ for the final rating of deviations

Frequency (Hz)	125	250	500	1000	2000	4000
Level (dB)	-22	-11	-6	-5	-6	-10

With the domain oriented and the randomly controlled evaluation it can be examined, if from the hurting of defined requirements systematic differences of the resulting errors arise.

With the randomly controlled evaluation the mean value m and the standard deviation s of the errors from single determinations is calculated. For a one number rating the weighted sum (48) is used.

$$f = |m| + |0.5 s| \quad (7/2)$$

As explained in the last chapter, this value is approximately the error that is exceeded in 30 % of all cases.

7.5.2 Results of the examination - evaluation for single points

This evaluation allows to decide, what position of measuring point gives the smallest error, if only one RSS-position shall be used. It also shows what regions of a room give a comparable level difference emission-immision.

With this evaluation also the mean values for measuring positions grouped with respect to their properties have been calculated. Table 11 shows this evaluation for RSS position d6 for condition „directional“ radiation.

Tab. 7.4 Mean deviations for grouped microphone positions RSS d6 - radiation directional (abbreviations look to text)

screening position	region criteria	half type absorption	number	frequency Hz						Total-A	
				125	250	500	1000	2000	4000	Qu	stand.
1	1	1	11	-1,3	1,7	2,2	-1,4	-1,6	0,5	1,1	0,3
1	1	2	4	-0,7	1,2	1,8	-0,8	-0,8	0,2	0,8	0,3
1	1	3	15	-1,2	1,6	2,1	-1,2	-1,4	0,4	1,0	0,3
1	2	1	33	-1,9	2,6	3,1	1,2	0,8	2,2	2,2	1,9
1	2	2	13	-2,6	1,4	1,5	0,6	0,3	1,8	1,2	1,0
1	2	3	46	-2,1	2,3	2,6	1,1	0,7	2,1	1,9	1,7
1	3	1	3	-1,2	3,4	3,4	1,4	0,7	2,9	2,7	2,3
1	3	2	3	-2,8	1,3	2,3	0,3	0,4	1,6	1,3	1,2
1	3	3	6	-2,0	2,4	2,8	0,8	0,6	2,3	2,0	1,7
1	4	1	52	-1,7	2,4	2,9	0,6	0,1	1,8	1,9	1,5
1	4	2	20	-2,2	1,4	1,7	0,3	0,1	1,4	1,1	0,9
1	4	3	72	-1,9	2,1	2,5	0,5	0,1	1,7	1,7	1,4
2	1	1	18	0,2	-0,2	0,5	-0,9	-1,7	-0,3	-0,3	-0,5
2	1	2	9	0,4	-0,5	0,5	-0,1	-0,4	0,9	-0,1	0,1
2	1	3	27	0,3	-0,3	0,5	-0,6	-1,2	0,1	-0,2	-0,3
2	2	1	17	-1,1	-1,1	1,0	0,0	0,3	1,5	0,0	0,5
2	2	2	18	-1,6	-1,2	0,4	0,2	0,2	1,2	-0,3	0,3
2	2	3	35	-1,4	-1,1	0,7	0,1	0,2	1,3	-0,1	0,4
2	3	1	4	0,4	-0,9	0,8	-0,3	-0,6	0,7	-0,1	0,1
2	3	2	3	-1,7	-2,0	0,4	0,1	0,0	1,6	-0,6	0,2
2	3	3	7	-0,5	-1,3	0,6	-0,1	-0,4	1,0	-0,3	0,1
2	4	1	45	-0,5	-0,6	0,8	-0,4	-0,7	0,6	-0,1	0,0
2	4	2	30	-1,0	-1,0	0,4	0,1	0,0	1,1	-0,2	0,2
2	4	3	75	-0,7	-0,8	0,6	-0,2	-0,4	0,8	-0,2	0,1
3	1	1	11	3,8	2,1	0,9	-0,6	-0,8	0,4	1,3	0,3
3	1	2	8	-0,6	0,4	1,0	0,5	0,1	1,4	0,5	0,7
3	1	3	19	1,9	1,4	1,0	-0,1	-0,5	0,8	1,0	0,4
3	2	1	29	-0,3	1,3	0,8	-0,5	-0,7	0,6	0,6	0,2
3	2	2	9	-0,8	-0,4	1,0	0,1	0,3	1,7	0,2	0,5
3	2	3	38	-0,4	0,9	0,9	-0,3	-0,5	0,9	0,5	0,2
3	3	1	3	0,6	2,7	1,1	0,1	-0,6	1,3	1,5	0,6
3	3	2	2	-0,8	0,0	0,5	0,0	0,3	1,7	0,2	0,4
3	3	3	5	0,0	1,6	0,8	0,0	-0,3	1,5	1,0	0,5
3	4	1	47	0,8	1,6	0,9	-0,4	-0,7	0,6	0,9	0,2
3	4	2	19	-0,7	0,0	0,9	0,2	0,2	1,6	0,3	0,6
3	4	3	66	0,3	1,2	0,9	-0,2	-0,5	0,9	0,7	0,3
4	1	1	40	0,8	1,0	1,1	-0,9	-1,4	0,1	0,5	-0,1
4	1	2	21	-0,2	0,2	0,9	0,0	-0,3	0,9	0,3	0,4
4	1	3	61	0,4	0,7	1,0	-0,6	-1,0	0,4	0,5	0,1
4	2	1	79	-1,1	1,3	1,8	0,3	0,1	1,4	1,1	1,0
4	2	2	40	-1,8	-0,1	0,9	0,3	0,3	1,5	0,3	0,6
4	2	3	119	-1,3	0,8	1,5	0,3	0,2	1,5	0,9	0,8
4	3	1	10	0,0	1,5	1,7	0,3	-0,2	1,5	1,2	0,9
4	3	2	8	-1,9	-0,2	1,1	0,1	0,2	1,6	0,3	0,6
4	3	3	18	-0,9	0,7	1,4	0,2	0,0	1,6	0,8	0,8
4	4	1	144	-0,5	1,2	1,6	-0,1	-0,4	1,0	0,9	0,6
4	4	2	69	-1,3	-0,1	0,9	0,2	0,1	1,3	0,3	0,5
4	4	3	213	-0,8	0,8	1,4	0,0	-0,3	1,1	0,7	0,6

Meaning of the numbers of the first 4 columns:

- screening position

- 1 measuring path is not screened from RSS by the model machine
- 2 measuring path is partially screened from RSS by the model machine
- 3 measuring path is completely screened from RSS by the model machine
- 4 no classification possible (all conditions 1 to 3 mixed)
this means a classification of all points of a path - partially means, that the nearest points are screened and the more distant points are unscreened).

- region criteria

- 1 the points in small distance where the V- and the DLf criterium is hurted
- 2 the points where no criterium of ISO 3747 is hurted
- 3 the last point with a distance of 0.5 m from the wall (hurting the criterium related to minimum wall distance)
- 4 no classification possible (all conditions 1 to 3 mixed)

- hall type absorption.

This value classifies the hall acoustically by the environmental correction K_2 related to the envelopping surface in 1 m distance of the model machine for the 1000 Hz band (this correction has no further meaning when measuring according to ISO 3747)

- 1 points in a hall with $K_2 \leq 2$ dB (big and/or much absorption - halls PL, DO and DU)
- 2 points in a hall with $K_2 > 2$ dB (small and/or reflecting - rooms PK, RH and GU)
- 3 no classification possible (all conditions 1 and 2 mixed)

- Number

This is the number of measuring points, that fulfil the named conditions and that have been included in the calculation of the mean value for that group.

The different results are not discussed here - they can be used in further discussions when questions about the influence of these properties arise.

The last line in Tab. 7.4 shows for all single measurements with RSS position d6 a mean deviation for the industry-spectrum (stand.) of 0.6 dB and table 12 with RSS position d1 (on top) of 0.1 dB. Nevertheless are the deviations in single frequency bands larger with the position on top of the source.

Tab. 7.5 Mean deviations for grouped microphone positions RSS d1 - radiation directional
(abbreviations look to text)

region criteria	room type absorption	number	frequency Hz						Total-A	
			125	250	500	1000	2000	4000	Qu	stand.
1	1	40	1.5	1.9	-0.6	-1.3	-2.0	-1.1	0.6	-0.7
1	2	21	-0.5	0.5	-1.1	-1.0	-1.7	-0.5	-0.3	-0.9
1	3	61	0.8	1.4	-0.8	-1.2	-1.9	-0.9	0.3	-0.8
2	1	79	-1.1	1.7	1.3	0.1	-0.5	0.8	1.1	0.6
2	2	40	-1.1	1.0	0.4	0.2	0.1	1.3	0.7	0.5
2	3	119	-1.1	1.5	1.0	0.1	-0.3	1.0	1.0	0.6
3	1	10	-0.3	0.6	0.5	-0.2	-0.9	0.2	0.4	0.1
3	2	8	-1.0	0.4	0.6	0.0	-0.3	1.3	0.3	0.3
3	3	18	-0.6	0.5	0.6	-0.1	-0.6	0.7	0.4	0.2
4	1	144	-0.3	1.7	0.7	-0.4	-0.9	0.2	0.9	0.2
4	2	69	-0.9	0.8	0.0	-0.2	-0.5	0.7	0.3	0.1
4	3	213	-0.5	1.4	0.5	-0.3	-0.8	0.4	0.7	0.1

These results show, that the use of ISO 3747 is quite accurate even when measuring at a single point.

This changes with undirection radiation, as expected. Tab. 7.6 and Tab. 7.7 show, that the deviations related to the measurement with a single point increase considerable.

Tab. 7.6 Mean deviations for grouped microphone positions RSS d6 - omnidirectional radiation - (abbreviation look to text)

screening position	region criteria	room type absorption	number	frequency (Hz)						Total-A	
				125	250	500	1000	2000	4000	Qu	stand.
1	1	1	11	-2.8	0.3	0.8	-2.8	-2.6	-1.0	0.0	-0.9
1	1	2	4	-1.0	1.9	0.2	-2.3	-1.7	0.1	1.1	-0.6
1	1	3	15	-2.3	0.7	0.7	-2.7	-2.4	-0.7	0.3	-0.8
1	2	1	33	-3.4	0.4	0.3	0.2	0.1	1.6	0.0	0.4
1	2	2	13	-3.8	-0.3	0.1	-0.2	-0.1	1.3	-0.4	0.1
1	2	3	46	-3.5	0.2	0.3	0.1	0.0	1.5	-0.1	0.4
1	3	1	3	-3.1	1.7	0.3	1.0	1.9	5.8	1.1	2.1
1	3	2	3	-4.7	-0.8	0.3	-0.6	-0.5	0.8	-0.7	-0.1
1	3	3	6	-3.9	0.5	0.3	0.2	0.7	3.3	0.2	1.0
1	4	1	52	-3.4	0.4	0.4	-0.4	-0.5	1.2	0.0	0.2
1	4	2	20	-3.4	0.1	0.2	-0.7	-0.5	1.0	-0.1	-0.1
1	4	3	72	-3.4	0.3	0.4	-0.5	-0.5	1.1	0.0	0.1
2	1	1	18	1.1	3.4	3.6	3.5	3.1	5.0	3.2	3.7
2	1	2	9	1.0	2.9	2.2	2.6	1.8	3.5	2.6	2.5
2	1	3	27	1.1	3.2	3.1	3.2	2.7	4.5	3.0	3.3
2	2	1	17	-0.3	0.8	2.7	2.6	2.7	4.8	1.4	2.9
2	2	2	18	-1.6	0.3	1.1	1.1	0.9	2.6	0.4	1.2
2	2	3	35	-0.9	0.5	1.9	1.8	1.8	3.7	0.9	2.0
2	3	1	4	1.1	2.1	3.8	3.8	4.4	6.0	2.8	4.2
2	3	2	3	-1.7	-1.3	1.8	1.9	1.3	3.1	-0.2	1.7
2	3	3	7	-0.1	0.6	2.9	3.0	3.1	4.7	1.5	3.1
2	4	1	45	0.4	2.1	3.2	3.1	2.9	4.9	2.4	3.3
2	4	2	30	-0.8	0.9	1.5	1.6	1.2	2.9	1.0	1.7
2	4	3	75	-0.1	1.7	2.5	2.5	2.2	4.1	1.8	2.6
3	1	1	11	5.2	7.1	5.7	4.7	5.0	6.6	6.6	5.6
3	1	2	8	1.3	4.3	4.4	4.0	4.2	6.2	4.1	4.5
3	1	3	19	3.5	5.9	5.1	4.4	4.7	6.5	5.5	5.1
3	2	1	29	0.9	4.4	5.1	4.6	4.6	6.1	4.4	5.0
3	2	2	9	-0.1	2.0	3.4	2.6	3.1	4.9	2.2	3.2
3	2	3	38	0.7	3.9	4.7	4.2	4.2	5.9	3.9	4.6
3	3	1	3	1.5	6.2	4.5	5.1	4.7	7.1	5.4	5.3
3	3	2	2	-1.5	3.5	3.0	2.7	2.7	4.7	3.0	3.1
3	3	3	5	0.3	5.1	3.9	4.2	3.9	6.1	4.4	4.4
3	4	1	47	2.0	5.3	5.2	4.6	4.6	6.2	5.0	5.1
3	4	2	19	0.3	3.1	3.8	3.2	3.5	5.4	3.1	3.7
3	4	3	66	1.5	4.7	4.8	4.2	4.3	6.0	4.5	4.7
4	1	1	40	1.2	3.5	3.4	2.1	2.0	3.8	3.3	2.9
4	1	2	21	0.7	3.3	2.7	2.2	2.0	3.9	2.9	2.7
4	1	3	61	1.0	3.4	3.1	2.1	2.0	3.8	3.1	2.8
4	2	1	79	-1.1	2.0	2.6	2.3	2.3	4.0	1.9	2.6
4	2	2	40	-2.0	0.5	1.3	1.0	1.1	2.7	0.5	1.3
4	2	3	119	-1.4	1.5	2.1	1.9	1.9	3.5	1.5	2.2
4	3	1	10	0.0	3.2	3.0	3.4	3.7	6.3	3.1	3.9
4	3	2	8	-2.8	0.1	1.5	1.2	1.0	2.6	0.4	1.4
4	3	3	18	-1.3	1.8	2.3	2.4	2.5	4.7	1.9	2.8
4	4	1	144	-0.5	2.5	2.8	2.3	2.2	4.0	2.4	2.8
4	4	2	69	-1.2	1.3	1.7	1.4	1.4	3.1	1.2	1.7
4	4	3	213	-0.7	2.1	2.5	2.0	1.9	3.7	2.0	2.4

Tab. 7.7 Mean deviations for grouped microphone positions RSS d1 - omnidirectional radiation (abbreviations look to text)

region criteria	room type absorption	number	frequency Hz						Total-A	
			125	250	500	1000	2000	4000	Qu	stand.
1	1	40	2.0	4.5	1.7	1.8	1.4	2.6	3.7	2.2
1	2	21	0.4	3.5	0.6	1.2	0.6	2.4	2.7	1.4
1	3	61	1.4	4.2	1.3	1.6	1.1	2.5	3.3	2.0
2	1	79	-1.1	2.3	2.1	2.1	1.7	3.3	2.0	2.2
2	2	40	-1.3	1.7	0.8	0.9	0.9	2.5	1.2	1.2
2	3	119	-1.2	2.1	1.6	1.7	1.4	3.1	1.7	1.9
3	1	10	-0.3	2.4	1.8	2.9	3.0	5.0	2.2	3.1
3	2	8	-1.9	0.7	1.0	1.0	0.4	2.3	0.7	1.1
3	3	18	-1.0	1.6	1.5	2.0	1.9	3.8	1.6	2.2
4	1	144	-0.2	3.1	2.0	2.0	1.7	3.2	2.6	2.3
4	2	69	-0.8	2.1	0.8	1.0	0.8	2.4	1.6	1.2
4	3	213	-0.4	2.8	1.6	1.7	1.4	2.9	2.2	1.9

This summary view shows, that the deviations grow with small K_2 and therefore with a low level of the sound field caused by the room. The deviations are larger with omnidirectional radiation, if the sound power level is determined only with one measuring point.

In Fig. 7.16 and Fig. 7.17 the deviations that are related to the industrial spectrum Tab. 7.3 are plotted in dependence of the distance source - measuring point. Fig. 7.16 shows this dependency for the source with directional radiation, where the measuring path is radial at the maximal radiating side and the measuring points are not screened. The RSS position is in front of this radiating area.

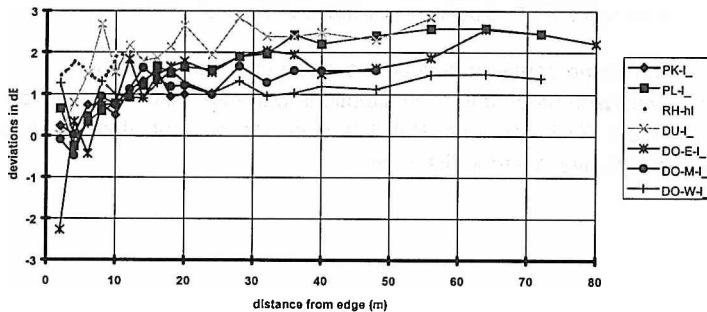

Fig. 7.16 Deviations with measuring at single points - path radial to radiating area - RSS position d6
Hall GU is not included in this evaluation, because in this hall no path is leading away from the radiating area.

PK and RH are small and/or reflecting halls with $K_2 > 2$ dB, PL, DU and DO are large halls partially with absorbent surfaces with $K_2 < 2$ dB.

DO-E is hall DO with the car in an edge, DO-M with the car in the middle and DO-W with the car at a wall.

The accuracy of all these measurements would be highest with a large distance and a systematic correction of -1.5 dB.

Fig. 7.17 shows this evaluation for the case of omnidirectional radiation. The deviations are certainly larger - the sound field caused by a uniformly radiating source with extension 4.5 m is certainly not similar to the sound field caused by a point source.

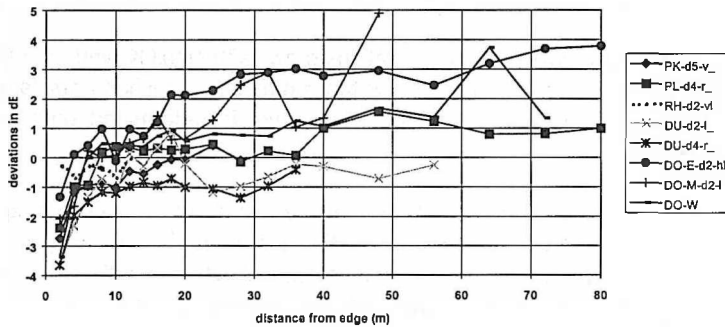

Fig. 7.17 Deviations with measuring at single points and omnidirectional radiation- path vertical to the longer side - RSS position in the middle of this side.

It makes therefore no sense to deduce too much conclusions from Fig. 7.17 - when using the comparison method in such situations with extended machines one should always use more RSS positions. But it is clearly seen that also in this case the deviations are positive in larger distances.

7.5.3 Results of the evaluation for domains

With the evaluation for domains for each room and for one of the criteria-regions all measuring points are included in the determination of the sound power level. The definition of the criteria-regions is the following:

- 1 the points in small distance where the V- and the DLf criterium is hurted
- 2 the points where no criterium of ISO 3747 is hurted
- 3 the last point with a distance of 0.5 m from the wall (hurting the criterium related to minimum wall distance)

Tab. 7.8 Results of the evaluation for regions related to the criteria
(dir. = directional)

hall	hurtet crit.	radiation		frequency Hz						Total-A	
		omnidir.	dir.	125	250	500	1000	2000	4000	Qu	Stand.
PK	DLf, V	x		0,8	2,1	1,3	1,9	1,6	3,3	1,8	1,9
	no	x		-1,0	1,5	0,9	1,6	1,6	3,2	1,1	1,6
	Wa.< 3m	x		-0,7	2,2	0,8	1,5	1,9	3,4	1,6	1,8
	DLf, V		x	0,6	0,1	0,8	0,7	0,5	1,9	0,5	0,8
	no		x	-0,8	1,4	1,0	1,1	1,3	2,5	1,2	1,3
	Wa.< 3m		x	-0,2	2,3	1,0	0,7	1,0	2,6	1,5	1,2
PL	DLf, V	x		1,8	3,4	2,8	2,8	2,2	3,9	3,0	2,9
	no	x		-1,0	2,1	3,8	2,5	2,3	4,0	2,2	3,0
	Wa.< 3m	x		1,6	1,0	2,2	3,0	3,4	4,5	1,8	2,8
	DLf, V		x	1,1	1,3	1,7	0,5	-0,2	2,0	1,1	1,0
	no		x	-0,4	1,9	2,5	1,6	1,2	2,7	1,8	1,9
	Wa.< 3m		x	2,3	1,4	2,7	3,0	2,4	3,6	2,2	2,8
RH	DLf, V	x		-0,1	1,7	-0,2	0,5	0,0	2,2	1,0	0,5
	no	x		-2,0	-1,2	-0,3	0,3	0,2	1,9	-1,0	0,2
	Wa.< 3m	x		-1,6	-1,5	0,6	1,4	0,2	1,9	-0,7	0,8
	DLf, V		x	-0,1	0,8	1,2	1,9	0,9	1,8	1,0	1,4
	no		x	-0,5	0,9	0,7	1,5	1,0	2,2	1,0	1,2
	Wa.< 3m		x	-0,7	0,8	1,6	1,2	0,9	2,0	1,0	1,3
DU	DLf, V	x		2,1	2,9	2,7	2,7	2,5	4,6	2,8	2,9
	no	x		-0,2	2,4	2,0	2,4	2,2	3,9	2,1	2,5
	Wa.< 3m	x		0,4	4,8	1,9	2,5	2,5	5,3	3,3	2,9
	DLf, V		x	1,5	1,0	1,7	0,7	0,4	2,1	1,1	1,1
	no		x	-0,1	3,3	3,3	1,9	1,3	3,4	2,7	2,5
	Wa.< 3m		x	1,5	4,3	4,2	2,1	0,9	3,5	3,4	2,8
DO	DLf, V	x		1,8	4,2	3,8	3,4	2,8	5,1	3,7	3,6
	no	x		-0,7	1,8	2,2	2,9	2,9	5,5	1,8	3,0
	Wa.< 3m	x		-0,4	2,3	2,9	3,9	4,6	9,1	2,4	4,7
	DLf, V		x	1,4	1,8	2,2	0,9	0,0	2,1	1,5	1,3
	no		x	-0,9	1,0	2,1	0,7	0,6	2,3	1,1	1,3
	Wa.< 3m		x	-1,5	1,0	2,0	0,5	0,0	1,9	1,0	1,0
GU	DLf, V	x		0,5	3,2	2,0	2,6	2,0	4,1	2,6	2,6
	no	x		-0,7	1,5	2,2	1,7	1,6	3,4	1,5	2,0
	Wa.< 3m	x		-1,6	2,6	1,8	1,8	1,6	3,2	2,7	2,0
	DLf, V		x	-1,5	-1,1	-1,4	-1,1	-2,1	-0,8	-1,4	-1,4
	no		x	-1,3	-0,8	-0,3	-0,8	-1,2	0,2	-0,7	-0,6
	Wa.< 3m		x	-0,7	-1,1	-0,8	-0,9	-0,9	0,3	-0,9	-0,7

The mean values show again, that the deviations are systematically positive. These deviations exceed 2 dB exactly with the halls, that belong to the group 1 with small room influence (PL, DU and DO).

7.5.4 Results of the evaluation with the statistical method

In difference to the described evaluations the procedure of ISO 3747 is exactly applied. For a single determination of the sound power level on each path is - controlled by a random generator - chosen one measuring point, where the interval of possible points is limited by the defined criteria. From this evaluation the deviations are calculated. The procedure is repeated so often, that it is shure that all points of such an interval have been used. Further this is repeated for all rooms of the chosen group.

With this technique the large - and because of the small room influence unfavorable - halls contribute more to the final result than the better suitable small halls. For this reason the evaluation is carried out separately for the two groups with K_2 lower or equal to 2 dB and larger than 2 dB

Tab. 7.9 Mean deviation in dB with statistical evaluation - radlation directional

Region	Hail type	number	frequency Hz						Total-A	
			125	250	500	1000	2000	4000	Qu	Stand.
near	K2 small	80	1,3	1,6	2,3	0,9	0,7	2,3	1,4	1,3
	K2 large	38	-0,6	-0,5	-0,2	0,0	-0,8	0,5	-0,4	-0,2
middle	K2 smali	142	0,9	2,2	2,7	1,4	1,0	2,8	1,9	1,9
	K2 large	68	-0,8	0,8	0,5	0,5	0,4	1,7	0,6	0,7
wall	K2 small	20	0,8	2,0	2,4	1,3	0,5	2,3	1,6	1,5
	K2 large	20	-0,6	0,8	0,5	0,3	0,2	1,5	0,6	0,5

Tab. 7.10 Mean deviation in dB with statistical evaluation - radiation omnidirectional

Region	Hall type	number	frequency Hz						Total-A	
			125	250	500	1000	2000	4000	Qu	Stand.
near	K2 small	80	1,7	3,6	3,1	3,0	2,5	4,4	3,2	3,1
	K2 large	38	0,7	2,9	1,5	2,1	1,6	3,5	2,3	2,1
middle	K2 small	142	-0,7	2,0	2,2	2,4	2,4	4,3	1,9	2,6
	K2 large	68	-1,0	1,2	1,1	1,5	1,4	3,0	1,0	1,6
wall	K2 small	20	0,4	2,6	2,4	3,3	3,4	6,3	2,5	3,6
	K2 large	20	-1,3	1,5	0,9	1,7	1,1	2,8	1,2	1,5

This evaluation shows like before, that the deviations rise in short distance range and near the wall. The deviations are also larger in the large and partially absorbent fitted halls with low room influence, although no criteria are hurted in the middle region and the measuring distance is large because of the DLf criterium.

7.5.5 Results of the examination - number of RSS positions

With the omnidirectional source it is principally possible to use 5 RSS positions d1 to d5 or alternatively only one position d1 on the top.

Therefore these two cases were examined separately and the nearest point of each path, that fulfils the DLf and V criterium, was used. Table 11 shows the deviations for 5 RSS positions d1 to d5, table 12 if the top-position d1 is used alone.

Tab. 7.11 Deviations - radiation omnidirectional no criterium hurted (RSS d1 - d5)

hall	frequency Hz						Total-A	
	125	250	500	1000	2000	4000	Qu	Stand.
PK	-0,8	1,2	1,4	1,5	1,6	3,1	1,1	1,7
PL	-1,1	1,8	2,4	1,7	2,1	3,5	1,7	2,2
RH	-1,6	-1,0	-0,2	0,8	0,1	2,0	-0,8	0,4
DU	0,5	2,8	1,6	1,8	2,1	3,2	2,3	2,1
DO	-0,7	1,8	1,9	2,0	2,3	4,2	1,6	2,3
GU	-1,3	1,9	2,0	1,9	1,5	3,6	1,6	2,0

Tab. 7.12 Deviations - radiation directional no criterium hurted (RSS d1)

hall	frequency Hz						Total-A	
	125	250	500	1000	2000	4000	Qu	Stand.
PK	-1,3	2,1	1,4	0,8	1,4	2,6	1,5	1,4
PL	-2,2	1,8	2,2	1,3	1,4	2,9	1,5	1,8
RH	-1,1	0,3	0,0	1,1	0,4	2,4	0,2	0,8
DU	-0,3	4,0	1,6	-0,2	1,0	1,2	2,9	1,2
DO	-0,6	2,4	2,1	2,0	1,9	4,0	2,0	2,3
GU	-1,7	2,9	1,8	0,8	0,5	2,4	2,1	1,4

So it can be stated, that with omnidirectional radiation one single RSS-position on top is sufficient - further RSS-positions don't improve the accuracy. This is valid even in those cases, where the measuring distance equals the dimension of the machine (hall RH).

7.5.6 Results of the examination - rotating microphone

In each hall one measurement has been carried out in a position, that fulfils all criteria of ISO 3747, with a rotating microphone. This measurement was also repeated for both conditions omnidirectional and directional and with all RSS positions d1 to d6. The sound pressure level was averaged over a time interval that is a multiple of the time needed for one cycle of the microphone rotation. In figure Fig. 7.9 the positions used for the measurement with rotating microphone are marked by a filled circle.

For the evaluation alternatively the spectra measured with fixed and with rotating microphone were used. All RSS positions d1 to d5 were included in this evaluation.

Table 20 shows the results for the measurement with fixed microphone positions, table 21 with rotating microphone.

Tab. 7.13 All RSS-Pos. d1 to d5 - fixed measurement positions

hall	Var.	path	point	frequency Hz						Total-A	
				125	250	500	1000	2000	4000	Qu	Stand.
PK		v_	7	-0,1	-0,4	0,0	1,6	1,2	2,7	-0,1	1,2
PL		l_	11	0,4	1,6	1,8	1,6	1,5	3,7	1,5	1,9
RH		vl	3	-1,6	-2,9	-0,6	0,1	0,2	1,9	-1,8	0,0
RH	m	vl	3	-3,1	-3,5	0,0	0,6	-0,3	1,2	-2,1	0,1
DU		l_	6	0,7	2,5	3,8	2,0	2,6	3,8	2,6	2,9
DO	e	hl	10	-3,5	0,1	2,9	3,3	3,1	4,6	0,9	3,1
DO	m	v_	10	-0,6	0,0	1,3	3,0	2,1	5,0	0,5	2,5
DO	w	v_	10	-0,5	1,3	0,9	1,8	2,3	4,4	1,1	2,1
GU		hr	6	-0,3	0,6	1,9	1,4	1,4	3,0	0,8	1,7
mean value				-1,0	-0,1	1,3	1,7	1,6	3,4	0,4	1,7

Tab. 7.14 All RSS-Pos. d1 to d5 - rotating microphone

hall	Var.	path	point	frequency Hz						Total-A	
				125	250	500	1000	2000	4000	Qu	Stand.
PK		v_	7	0,1	0,7	0,7	1,2	1,6	3,0	0,7	1,4
PL		l_	11	-0,5	1,1	1,9	2,4	2,3	3,9	1,2	2,3
RH		vl	3	-1,6	-0,8	-0,5	-0,5	0,0	1,6	-0,8	-0,1
RH	m	vl	3	-1,8	-1,6	-0,5	-0,1	0,0	1,5	-1,2	-0,1
DU		l_	6	-0,2	1,5	2,2	1,2	1,3	3,2	1,4	1,8
DO	e	hl	10	-3,6	0,1	2,3	2,2	2,5	4,1	0,6	2,4
DO	m	v_	10	0,6	0,7	2,1	3,3	2,9	4,9	1,3	3,0
DO	w	v_	10	-0,5	0,0	0,7	0,7	1,0	4,2	0,2	1,2
GU		hr	6	-1,3	0,6	1,3	1,8	1,4	3,2	0,7	1,7
mean value				-1,0	0,2	1,1	1,4	1,4	3,3	0,4	1,5

Although with rotating microphone the deviations are a bit smaller, this is not very significant - the little improvement doesn't justify the additional effort on time and instrumentation.

7.6 The use of indicators

In ISO/DIS 3747 1997-10-20 (Layout after the Hamamatsu meeting og WG 28) the use of several indicators was proposed. These indicators should prove the similarity of the sound fields of the reference sound source and of the source under test.

The application of these indicators was also tested in an additional examination. Some results are published in /17/ and /18/.

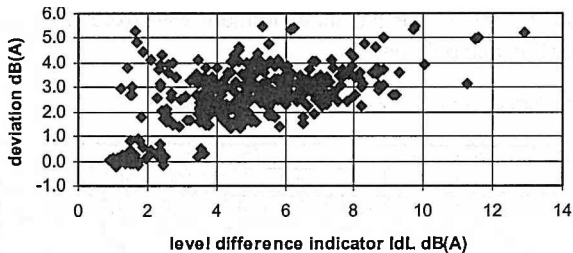

Fig. 7.18 Omnidirectional radiation, all microphone positions, RSS 1 - 4, all rooms

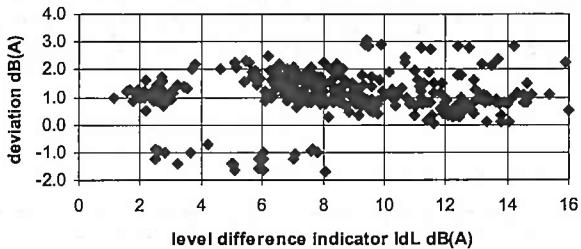

Fig. 7.19 Radiation directional, all microphone positions, RSS 1 - 4, all rooms

Figures 7.18 and 7.19 show two examples of a summarized evaluation for the dependence between the deviation and the level difference indicator I_{dL} . For each point in the diagram the sound power level has been determined with the application of 4 RSS positions at the sides of the car and one microphone position. Therefore many bad combinations, that would never be used in practically, are included. The diagrams show that the correlation between the „badness“ of a RSS-microphone-

combination, quantified as deviation determined value and true value, and the level difference indicator is rather weak. Many other evaluations for selected groups of such combinations show the same tendency.

One reason may be, that the sound fields of ST (source under test) and RSS (reference sound source) are not similar. The sound field of RSS is that of a point source and omnidirectional, while the ST has not negligible dimensions and may even radiate directional. Therefore we simulate the radiation of this bigger machines with more than one RSS-positions. The indicators are a measure of the largest difference and don't take into account this simulation of the ST-field by a superposition of the sound fields of more than one RSS-positions.

7.7 Summary - recommendations for the use of ISO 3747

In summary it can be stated, that the procedure of ISO 3747 is a time saving and economic alternative to the envelopping surface method according to ISO 3744/3746.

The deviations were systematically positive in all experiments and with all evaluation procedures - the results would be in accordance to accuracy class 2, if a negative correction of 1.5 dB was used.

This „overestimation“ of the sound power grows with distance. Therefore it is not possible to get higher accuracies by locating the measuring points at distances with a very large DLf. The DLf criterium makes sense to ensure the necessary minimum distance in dependence of the room properties - a further improvement by choosing even larger distances is not possible.

By taking into account the „unsharpness“ of the relation DLf - accuracy it is clearly sufficient to use one mean sound decay curve of the hall to find the proper distance where the DLf criterium is fulfilled. It is not necessary to measure DLf for each direction with measuring points separately.

With the number of measurements made the increase of deviation with distance can be stated to be statistically sure. The absolute value of this deviation is more problematic - it depends on the accuracy of the free field measurement. An error of x dB in the determination of the sound power level with the intensity method would directly produce an error of $-x$ dB in the final evaluation (insofar it is stated selfcritical, that a repetition of this reference measurement would have been helpful).

High values of DLf because of a high reflectivity of the room surfaces proved to be advantageous. The largest halls gave the largest deviations. The evaluations at

single measuring points showed, that the measuring distance should be about twice the largest machine dimension.

A special arrangement of RSS positions that could improve the accuracy was not found. Nearly trivial is the result, that with the model machine with directional radiation the best position of the RSS is exactly in front of this radiating surface area. In all other cases the positioning on the top - with machines of small height - or alternatively in front of all surfaces - with machines of large height - is recommendable.

The measuring distance should not be larger than 20 m and not smaller than twice the largest machine dimension. The latter is valid if only one measuring position is used. The DLf criterium should be reduced to $DLf > 7$ dB.

A rotating microphone does not improve the accuracy significantly.

Summing up it can be stated, that the comparison method according to ISO 3747 is a very interesting technique to determine sound power levels, because it affords less time than the envelopping surface method without loss of accuracy. The results are in accordance with accuracy class 2, if certain limitations to room properties are accepted. This is even the case, if only one measuring point is used, if the dimensions of the machine are smaller than half the measuring distance. The accuracy is limited by the differences in sound propagation for the sources RSS and machine and can not be improved by larger distances or many measuring positions.

From this the range of application of the procedure can be deduced. The machine should be installed in a position, that the measuring distance can be large enough. The problem in factories is always the background noise, because the levels caused by the machine under test are often too low at these distances. Particularly with machines coupled mechanically, electrically or by the material flow or linked otherwise to a production line the use of the method will fail for reasons of background noise.

On the other side it is very useful with big machines, if these can be operated alone. Examples are presses, punching machines, big palettizing and packing machines or printing machines.

As the applicability doesn't depend so much on the type of machine, but more on the mounting conditions, the environment and the integration into the complete plant, it will be difficult to define ISO 3747 to be the compulsory measurement method for a certain machine family. The ISO 3747 method should be offered as an alternative method in the machine specific C-standards, so that it can be used to reduce the expenditure, if this is allowed by the environmental conditions.

7.8 Proposal for an improvement of ISO 3747 - The selection of RSS and microphone positions

7.8.1 Determination of the minimum distance with $DL_r > 7$ dB

The sound decay curve typical for that part of the room is measured **once** with a RSS position in 1,5 m height and no reflecting wall nearby (minimum distance 3 m).

If the frequency spectrum of the RSS-emission is similar to that of the ST, the sound decay curve is related to A-levels. Other wise it is measured in frequency bands and the decay curve A-weighted levels related to the spectrum of the ST is calculated.

If spectra of ST and RSS differ, but spectrum of ST is typical broad band with maximum at 500 Hz - 1000 Hz when A-weighted, the decay curve of the 1000 Hz octave band can be used.

From this curve the minimum distance d_0 with

$$DL_{IA} \geq 7 \text{ dB}$$

is determined.

7.8.2 Determination of main radiating areas and their extension

The normal case is 5 radiating areas (4 sides and top). The special case of only the top radiating and absorbing ceiling is excluded here (measurement in this case with approximation method chapter 4).

Walk along a parallel path in about 1 m distance from the contour of the reference box with the ST in operation and measure the SPL.

Find for each side i

- the mean value $SPL_{eq,i}$ by integration along the walk
- the maxima with $SPL_{max,K,i} > SPL_{eq,i} + K$
- the extension of each radiating area with $SPL > SPL_{max,K,i} - K$ dB
K should be preferably 3 dB.

With this method some more or less extended radiating areas are located. If there is no SPL_{max} with a level excess of K dB, the whole side is treated as radiating area further.

7.8.3 Determination of RSS positions

If the RSS - can be placed on the top surface of the machine and

- it is not screened in this position at the selected measuring distance by the machine structure itself and
- the extension of the ST along a line through the microphone position is less than half of the distance microphone - nearest surface of ST

the RSS positions are on the top surface of the ST.

To find the necessary number of RSS positions in this case the top surface is regarded as one radiation area.

If the RSS is not placed on top of the ST, one RSS position is chosen in front of the middle of each vertical radiating area.

Two radiating areas located at the same side can be replaced by one RSS position in the middle, if the SPL measured at the microphone position in distance r_0 from RSS rectangular to this side differs less than 2 dB for the two RSS positions. The maximum distance of radiating areas that can be taken into account by one RSS position can also be found by moving the microphone on a sideline of the ST box with the operating RSS at rest and by determining the distance, where the SPL drops about 2 dB.

For an extended radiation area, e.g. the whole side regarded as radiating area, operate the RSS in front of the middle of this side and measure the SPL in the chosen distance d. Now move the microphone parallel to the contour of the reference box and determine the distance e, where the SPL drops 2 dB relative to the starting position. If the extension of this radiation area (normally the length of this side of the reference box) is l, then the number of RSS positions is

$$n = \text{INT} \left(\frac{l}{2e} + 0,5 \right)$$

7.8.4 Determination of microphone positions

One microphone position is chosen in front of each RSS position.

From this procedure we get

- with machines of low height and not extended 1 RSS and 1-4 Mic.
- with height > 2 m and not extended 4 RSS and 1-4 Mic.

But even with big machines of any dimension the number of RSS and microphone positions can be derived by applying the rules above.

8 Literature

- /1/ EU-Council-Directive 89/392/EEC of 14 June 1989 on the approximation of the laws of the member states relating to machinery, O.J.L 183, 29 June 1989 p. 9
- /2/ Probst W. „Determination of sound emission of big machines with approximate methods“ (in german), research report series of BAuA, Fb 680, Dortmund 1993
- /3/ Probst W. and van den Brulie, P. „Testing of approximate methods for emission measurement procedures with big machines“ (in german), research report series of BAuA, Fb 781, Dortmund 1997
- /4/ Hübner G. and Wu, J. „Round robin test determining the sound power by sound pressure measurements according to ISO 3744 - first results“, *Inter Noise* 1993, p.323-328
- /5/ Hübner G. and Wu, J. „National round robin test determining the sound power by sound pressure measurements - further results“, *Inter Noise* 1994
- /6/ Probst, W. „Numerical Simulation of the Determination of the Sound Power Level for Machines - The Angle Error Using the Enveloping Surface Method“, *ACUSTICA* Vol. 68 (1989),150 - 156, S.Hirzel Verlag Stuttgart
- /7/ Probst W. „Sound radiation and sound propagation, calculation models and sound power determination (in german)“, research report series of BAuA, Fb 556, Dortmund 1988
- /8/ Payne, Richard C.: „The establishment of a rapid method of making sound power measurements of machinery noise emission“, *proceedings of Inter Noise* 1998
- /9/ Andresen G. and Jonasson H. : „Determination of emission sound pressure levels in situ - a comparison between different methods“, *proceedings Inter Noise* 1998
- /10/ Sehrndt, G. und Biehn, K.: „Remarks about the local environmental correction for determination of the emission sound pressure level“, *proceedings of Inter Noise* 1998
- /11/ Sehrndt G., Probst W. and Biehn K : „Directivity of machines and the sound field in situ - experience with standard ISO 11204“, *proceedings of Inter Noise* 1998
- /12/ Jonasson H.and Geir A. : „Measurement of emission sound pressure levels using sound intensity“, *Nordtest project 1129-93, Swedish National Testing and Research Institute, SP Report 1995:75*
- /13/ Hübner, G. und Gerlach, A. : „Determination of emission sound pressure levels using sound intensity measurements - comparison of different intensity methods“, *proceedings Inter Noise* 1998
- /14/ Hübner, G. und Gerlach, A. : „Bestimmung des Emissionsschalldruckpegels am Arbeitsplatz mit Hilfe von Schallintensitätsmessungen - Grundlagen und erste Ergebnisse“
- /15/ Hübner G. and Gerlach A. : „Determination of emission sound pressure levels using three component sound intensity measurements“, *proceedings Euro-Noise 1998, munich*
- /16/ Herraez M. and Machimbarrena M. : „On the requirements on the F_p indicator when determining emission sound pressure levels using sound intensity“, *proceedings Inter Noise* 1998
- /17/ Probst W., Sehrndt G. and Biehn K, „On the appropriate distance between microphones and source for the comparison method ISO 3747“, *proceedings of Inter Noise* 1998
- /18/ Probst W., Sehrndt G. and Biehn K, „Additional remarks to the Inter Noise '98 contribution : On the appropriate distance between microphones and source for the comparison method ISO 3747“, *report for WG 28 meeting 98/11/11*
- /19/ Jonasson, H. : „The revised comparison method ISO 3747 for determining the sound power level of machines in situ“, *proceedings Inter Noise* 1998

ISSN 1433-2086
ISBN 3-89701-375-4