

Environmental and Social Impact Assessment
of the Deception Bay Wharf and
Sediment Management

Main Report

VOLUME 1

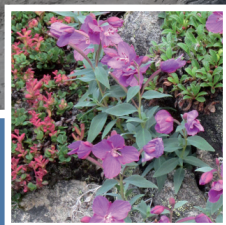
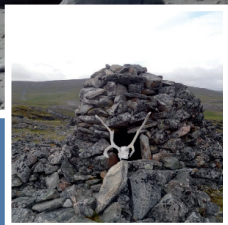

Presented to
Canadian Royalties Inc.

By

GENIVAR inc.

Prepared by:

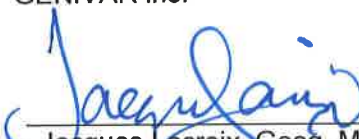

Jacques Lacroix, Geog. M. Sc
Project Manager

Natalie Gagné, Eng. M. Sc
Project Manager

Approved by :



Simon Latulippe, Eng.
Project Director

NOVEMBER 2012
101-53046-02

NOTE TO THE READER

THIS DOCUMENT IS A TRANSLATION OF A DOCUMENT ORIGINALLY WRITTEN IN FRENCH.

PROJECT TEAM

Canadian Royalties inc.

Vice-President
Health and Safety - Environment : Gail Amyot

Superintendent - Environment : Stephane Twigg

GENIVAR Inc.

Project Manager : Simon Latullipe, eng.

ESIA Managers : Jacques Lacroix, geographer, M. Sc.
Natalie Gagné, eng. M. Sc.

Collaborators : Patrick Charbonneau, Biologist. M. Sc.
Jean Deshayes
Claire Dubé, anthropologist, M.Sc.
Marc Gauthier, biol., Ph.D.
Mélanie Lévesque, oceanographer, M.Sc.
Vincent Métivier, Jr. eng., M.Sc.
Edith Normandeau, M.Sc. land-use planner
Jean-François Poulin, biologist, M. Sc.
Julie Simard, geomorphologist, Ph. D.
Steve Renaud, eng. M.Sc.

Field team : David Ouzilleau Samson, geographer M. Sc.
Philippe Charest-Gélinas, biologist
Nathalie Guérard, diver, fauna technician
Frédéric Milord, diver, fauna technician
Mathieu Monast, Professional diver
Kevin Chalifoux-Moisan, Professional diver
Vincent Métivier, eng. M. Sc.
Pierre Hébert, hydraulic technician
Mélanie Lévesque, oceanographer M. Sc.
Benoit Chabot, fauna technician

PROJECT TEAM (CONT.)

Inuits Collaborators	:	Quppa Tarkik Putu Qumaaluk Adamie Kiatainak Willie Kiatainak
Mapping and geomatics	:	Jean-Marc Tremblay
Edition	:	Linette Poulin
Traductors	:	Open Text Lynda Hayes Courtney Aikman Hugues Chicoine Sara Anne Bilodeau Valérie Fortin, ing. jr

Référence à citer :

GENIVAR. 2012. *Environmental and Social Impact Assessment of the Deception Bay Wharf and Sediment Management*. Report from GENIVAR for Canadian Royalties Inc.. 281 p. and appendices.

TABLE OF CONTENTS

	Page
Note to the reader.....	i
Project team.....	i
Table of contents	iii
List des tables.....	xi
List des figures.....	xv
Liste des maps.....	xvii
List of appendices - Volume 2	xix
List of appendices - Volume 3	xxiii
List of acronyms.....	xxv
1. INTRODUCTION.....	1
1.1 Setting the Context.....	1
1.2 Project Justification	2
1.3 Legal and Regulatory Framework	3
1.3.1 James Bay and Northern Québec Agreement	3
1.3.2 Sanarrutik Agreement	3
1.3.3 Environmental assessment process.....	3
1.3.4 Environmental requirements	4
1.3.5 Detailed design of the project.....	5
2. STUDY AREA.....	7
2.1 Generalities	7
2.2 Port and Navigation Infrastructures.....	7
2.2.1 Port infrastructures	7
2.2.2 Navigation	7
2.3 Land Disposal Site and Access Road	8
3. DESCRIPTION OF THE PROJECT'S VARIANTS.....	11
3.1 Port Infrastructures.....	11
3.1.1 Generalities	11
3.1.2 Comparative analysis of variants	11
3.2 Management of Dredged Sediments.....	12

TABLE OF CONTENTS (cont.)

	Page
3.3 Disposal Sites for Dredged Sediments	14
3.2.1 Generalities	14
3.2.2 Description and location of sites 1 to 4	14
3.2.3 Description and location of sites A to E.....	15
3.2.4 Comparative analysis of variants	15
4. SCOPE OF THE ENVIRONMENTAL ASSESSEMENT AND CONSULTATIONS WITH THE INUIT.....	19
4.1 Scope of the Environmental Assessment	19
4.2 Public Consultations and Other Meetings with Stakeholders.....	20
4.2.1 Public consultations carried out by the CRI in 2006 in Salluit, Kangiqsujuaq and Purvinituq	22
4.2.1.1 Concerns raised	22
4.2.1.2 Business opportunities and the local economy.....	25
4.2.1.3 Environmental impacts and impacts on the practice of traditional activities	27
4.2.2 Consultation with communities, stakeholders and regional representatives – spring 2012.....	29
4.2.3 Meetings held in Salluit and Kangiqsujuaq in September, 2012	31
5. METHODOLOGY.....	33
5.1 Physical Environment.....	33
5.1.1 Review and Analysis of the Existing Information	33
5.1.2 Sedimentological and Oceanographic Survey Campaigns	33
5.1.3 Core Sampling and Description of Sediments	34
5.1.4 Water Level Measurements	34
5.1.5 Bathymetric Surveys	37
5.1.6 Current Measurements, Waves and Flow.....	37
5.1.6.1 Drifters	37
5.1.6.2 ADCP	37
5.1.7 Turbidity and CTD Sensors.....	38

TABLE OF CONTENTS (cont.)

	Page
5.2 Biological Environment.....	38
5.2.1 Marine Environment.....	38
5.2.1.1 Benthic Wildlife Inventory Protocols for 2007, 2008 and 2011.....	38
5.2.1.2 2012 Field Campaign – Benthic Fauna and Aquatic Grass Beds.....	43
5.2.2 Terrestrial Environment.....	44
5.2.2.1 Special-Status Plant Species.....	44
5.3 Human Environment.....	45
6. DESCRIPTION OF THE ENVIRONMENT.....	47
6.1 Physical Environment.....	47
6.1.1 Geology.....	47
6.1.2 Geomorphology.....	49
6.1.2.1 Relief and Bathymetry.....	49
6.1.2.2 Stratigraphic Context and Surface Deposits.....	50
6.1.2.3 Dynamic Terrestrial Geomorphology.....	56
6.1.3 Climate.....	60
6.1.3.1 Climate Means.....	60
6.1.3.2 Wind Regime.....	62
6.1.3.3 Sea Ice.....	62
6.1.3.4 Climate Change and Outlooks.....	65
6.1.4 Physical Oceanography.....	68
6.1.4.1 Tides and Water Level.....	68
6.1.4.2 Waves.....	68
6.1.4.3 Flow and Currents.....	73
6.1.4.4 Water Physicochemistry.....	79
6.1.5 Sediment Quality.....	81
6.1.6 Hydrosedimentary Dynamics.....	101

TABLE OF CONTENTS (cont.)

	Page
6.1.7 Marine Sound Environment.....	102
6.1.7.1 Ambient Noise	102
6.1.7.2 Sound Attenuation	103
6.2 Biological Environment.....	103
6.2.1 Marine Environment.....	103
6.2.1.1 Aquatic Grass Beds	103
6.2.1.2 Benthic Fauna	104
6.2.1.3 Ichthyofauna	119
6.2.1.4 Marine Mammals	120
6.2.1.5 Special-Status Species.....	131
6.2.2 Terrestrial Environment.....	132
6.2.2.1 Flora	132
6.2.2.2 Mammals	135
6.2.2.3 Avifauna	136
6.2.2.4 Special-Status Species.....	136
6.3 Human Environment	138
6.3.1 General	138
6.3.2 Sociopolitical and Institutional Frameworks	139
6.3.2.1 Kativik Regional Government	139
6.3.2.2 Makivik Corporation	140
6.3.2.3 Northern Villages and Municipal Councils	141
6.3.2.4 Landholding Corporations.....	141
6.3.2.5 Kativik School Board	142
6.3.2.6 NRBHSS and Health Centres.....	142
6.3.2.7 Other Bodies	143
6.3.3 Agreements.....	143
6.3.3.1 Sanarrutik and Sivunirmut Agreements	143

TABLE OF CONTENTS (cont.)

	Page
6.3.3.2 Nunavik Inuit Land Claims Agreement.....	143
6.3.3.3 Nunavik Nickel Agreement.....	144
6.3.4 Sociodemographic Framework.....	145
6.3.4.1 Demographic Situation.....	145
6.3.4.2 Health	146
6.3.4.3 Housing	148
6.3.4.4 Transportation	149
6.3.4.5 Economic Context	150
6.3.4.6 Economically Active Population and Labour Market.....	151
6.3.5 Use of Land and Resources.....	152
6.3.5.1 Land and Resource Management and Development	152
6.3.5.2 Inuit Use of the Territory	152
6.3.6 Archeological Potential.....	158
6.3.7 Landscape.....	160
7. PROJECT DESCRIPTION	163
7.1 Wharf infrastructures	163
7.1.1 Location.....	163
7.1.2 Permanent wharf	164
7.1.3 Temporary wharf	170
7.1.4 Piles driving	173
7.1.5 Dredging.....	174
7.1.5.1 Description of the work	174
7.1.5.2 Sediment dispersion	174
7.1.6 Riprap.....	176
7.1.7 Maintenance.....	176
7.1.8 Geotechnical considerations	177
7.2 Transshipment of ore	178

TABLE OF CONTENTS (cont.)

	Page
7.3 Navigation	185
7.3.1 Ballast water and invasion of foreign species	186
7.4 Disposal site for the dredged sediment.....	186
7.4.1 Dredged sediment transportation.....	189
7.4.2 Water management.....	189
7.5 Closing and decommissioning	190
7.5.1 Wharf	190
7.5.2 Management sediment site.....	190
7.6 Completion schedule.....	190
7.7 Costs of the work	190
7.8 Required equipment.....	192
7.9 Estimation of required personal	192
8. ASSESSMENT OF ENVIRONMENTAL EFFECTS	193
8.1 Method for identifying and assessing environmental effects.....	193
8.1.1 Determining the magnitude of an environmental effect.....	193
8.1.1.1 Intensity of the effect	193
8.1.1.2 Degree of disturbance	195
8.1.1.3 Intensity	195
8.1.2 Duration/intensity association	196
8.1.2.1 Duration of the effect	196
8.1.2.2 Duration / intensity index	196
8.1.3 Magnitude of the effect	196
8.1.3.1 Extent of the effect	197
8.1.3.2 Extent/duration/intensity relationship	197
8.1.4 Mitigation measures and residual environmental effects	198
8.2 Analysis of environmental effects.....	198
8.2.1 Port infrastructures.....	200
8.2.2 Sediment dump.....	233

TABLE OF CONTENTS (cont.)

	Page
8.3 Principal issues	244
8.3.1 Marine Mammals.....	244
8.3.1.1 Dredging	245
8.3.1.2 Drilling of piles and sheet piles	245
8.3.1.3 Navigation	247
8.3.1.4 Inuit use of the land for traditional purposes	249
8.4 Fish habitat.....	250
8.5 Environmental impacts on the project	251
8.5.1 Earthquakes	251
8.5.2 Ice.....	251
8.5.3 Avalanche.....	251
8.6 Cumulative effects.....	252
8.6.1 Legal framework and general.....	252
8.6.2 Scope of the study.....	252
8.6.2.1 Study area and period covered.....	252
8.6.2.2 Valued environmental components.....	252
8.6.2.3 Past, present and future activities, projects and events.....	252
8.6.3 Analysis of cumulative effects	254
8.6.3.1 Marine mammals	254
8.6.3.2 Inuit use of the land for traditional purposes	257
8.6.3.3 Fish habitat	258
9. ENVIRONMENTAL MONITORING AND FOLLOW-UP PROGRAMS	259
10. RÉFÉRENCES	265

LIST DES TABLES

	Page
Table 3.1	Analysis of Variants – Port Infrastructures 13
Table 3.2	Analysis of Variants – Land disposal of the sediments 17
Table 4.1	Summary of meetings between CRI and stakeholders – August 2008 to October 2012..... 21
Table 6.1	Design criteria chosen for infrastructure earthquake resistance 49
Table 6.2	Typical sedimentary sequence of the Deception Bay region. 50
Table 6.3	Monthly and annual mean temperatures at Deception Bay from 1963 to 1973. 60
Table 6.4	Number of degree-days at Iqaluit (Climate normals 1971 to 2000)..... 61
Table 6.5	Mean precipitation at Deception Bay from 1963 to 1973. 61
Table 6.6	Anticipated warming of temperatures in Nunavik for 2020 and 2050, relative to the data for the 1980s (modified from Ouranos, 2007)..... 66
Table 6.7	Anticipated variation of precipitation in Nunavik for 2020 and 2050, in relation to the data for the 1980s (modified from Ouranos, 2007)..... 66
Table 6.8	Deception Bay tide table 70
Table 6.9	Weather conditions observed at Salluit Airport on September 13 and 14, 2012 (Environment Canada, 2012). 70
Table 6.10	Descriptive statistics of current speed different depths in Deception Bay between September 5 and 29, 2006. 73
Table 6.11	Drifter displacement speeds near sites Q1 and Q2..... 76
Table 6.12	Displacement speeds of drifters offshore from the Canadian Royalties camp on August 2, 2012..... 77
Table 6.13	Temperature and salinity values of deep water layer of Transect 1 (August 2012)..... 79
Table 6.14	Concentration of suspended particulate matter measured near sites Q1 and Q2, August 5, 2012..... 80
Table 6.15	Descriptive statistics on suspended particulate matter near sites Q1 and Q2 (August 5, 2012) 81
Table 6.16	Sediment quality at site Q1 (July 2012)..... 85
Table 6.17	Typical underwater sound pressure levels measured directly in Deception Bay on July 12, 2012..... 103
Table 6.18	Sound attenuation at sites Q1 and Q2. 103

LIST DES TABLES (Cont.)

	Page
Table 6.19	Inventory and estimate of coverage (%) of aquatic grass beds found at sites Q1 and Q2107
Table 6.20	Epibenthic fauna inventory at sites Q1 and Q2.....109
Table 6.21	Densities of endobenthic invertebrates (number of organisms/m2) measured at sites Q1 and Q2, August 2012111
Table 6.22	Diversity indices for the 16 stations sampled at sites Q1 and Q2 in Deception Bay, August 2012.119
Table 6.23	Main fish species present in Deception Bay, likely to use the study zone.121
Table 6.23	Main fish species present in Deception Bay, likely to use the study zone (continued).122
Table 6.24	Marine mammals likely to use Deception Bay123
Table 6.25	Characteristics of the main marine mammals likely to frequent Deception Bay (GENIVAR, 2007b).125
Table 6.26	Land mammals likely to be present in the Deception Bay sector.....135
Table 6.27	List of bird species observed in the study zone137
Table 6.28	List of special-status bird species likely to frequent the study area138
Table 6.29	Sociodemographic data for Salluit and Kangiqsujuaq in comparison with Québec as a whole in 2011 and 2006145
Table 6.30	List of the main wildlife species harvested by the Salluit and Kangiqsujuaq communities (Thiffault 2007, GENIVAR, 2007 and 2007b).....157
Table 7.1	Comparison of the different wharf concepts.....170
Table 7.2	Estimated volumes of riprap and structures areas.....176
Table 7.3	Summary of safety factors177
Table 7.4	Permanent Wharf191
Table 7.5	Temporary Wharf191
Table 7.6	Machinery and equipment.....192
Table 7.7	Estimated number of workers192
Table 8.1	Grid for evaluating the importance of components of the biological and human environments195
Table 8.2	Grid for assessing an impact's intensity.....195
Table 8.3	Grid for assessing the duration - intensity index196

LIST DES TABLES (Cont.)

	Page
Table 8.4	Grid for assessing the effect's significance 198
Table 8.5	Identification of potential effects matrix - Temporary and permanent port infrastructures 202
Table 8.6	Identification of potential effects matrix of the land sediment dump..... 234
Table 8.7	Surface areas of affected fish habitat 250
Table 8.8	Summary of present and future activities, projects and events likely to have affected or affect VECs..... 253
Table 9.1	Limit Values 263

LIST DES FIGURES

	Page
Figure 6.1	Geological provinces of Québec and tectonostratigraphic units (modified from GENIVAR, 2007 and Mouksil, 1996)..... 47
Figure 6.2	Lithology of the study site (modified from Lamothe, 2007)..... 48
Figure 6.3	Debris cone from the 2005 slush flow, related to winter thaws (CEN, 2012). 59
Figure 6.4	Wind roses for Deception Bay and Salluit 63
Figure 6.5	Freeze-up and break-up dates for the Arctic region (Environment Canada, 2012)..... 64
Figure 6.6	History of the percentage of ice coverage in the Hudson Strait sector..... 65
Figure 6.7	Water level measured in Deception Bay between August 8 and September 15, 2012 (CD). The red line shows the bay water level variation caused by the passage of atmospheric disturbances. The levels are all represented relative to the Chart Datums. 69
Figure 6.8	Variation of the water level in Deception Bay between September 6 and 16, 2012 (CD). The line represents the atmospheric component of the water levels measured. 71
Figure 6.9	Recorded series of the significant height of waves, their period and the tide measured between September 5 and 22, 2006 (modified from GENIVAR, 2007a)..... 72
Figure 6.10	Recorded series of the significant height of the waves, their period and the tide measured between September 22 and 29, 2006 (modified from GENIVAR, 2007a)..... 72
Figure 6.11	Current speeds measured between September 5 and 29, 2006 at station 1200 located at a depth of 11 m. The bottom portion shows the speeds at 10.5 m, 6.8 m and 3.0 m..... 74
Figure 6.12	Currentometric profile produced in Section T1, August 3, 2012..... 75
Figure 6.13	Currentometric profile produced in Section T2 – August 2, 2012..... 75
Figure 6.14	Canadian Sediment Quality Guidelines (CCME, 1999) Québec sediment quality criteria (taken from Environment Canada and MDDEP, 2007). 83
Figure 6.15	Proportions of phyla collected at site Q1, August 2012..... 118
Figure 6.16	Proportions of phyla collected at site Q21, August 2012..... 118
Figure 7.1	Permanent Dock Facility Concept 179
Figure 7.2	Permanent Dock Facility Concept 180
Figure 7.3	Transfer points 181
Figure 7.4	Temporary Dock Facility Concept 182

LISTE DES MAPS

		Page
Map 2.1	Study Area.....	9
Map 5.1	Sampling Stations Locations for Sediment Physicochemical and Granulometric Analysis	35
Map 5.2	Location of Water Physicochemical Sampling Stations, ADCP Transects and Water Level Gages.....	39
Map 5.3	Suspended solids sampling stations location, August 2012.....	41
Map 6.1	Relief and Bathymetry	51
Map 6.2	Surface deposits and geomorphology.....	53
Map 6.3	Trajectory of Drifters on August 1, 2 and 5, 2012 and Outlook of Hydrodynamic Conditions	77
Map 6.4	Benthos and Aquatic-Grass Bed Characterization Stations Locations for Q1 and Q2 sites, August 2012.....	105
Map 6.5	Traditional Land Use	155
Map 6.6	Human Environment.....	159
Map 7.1	General Layout.....	165
Map 7.2	Permanent Wharf Layout Concept.....	167
Map 7.3	Temporary Wharf Layout Concept	171
Map 7.4	Sediment Disposal Site	183
Map 7.5	Ships Path.....	187
Map 8.1	Proposed Marine Mammal Monitoring Area.....	246

LIST OF APPENDICES

VOLUME 2

- APPENDIX 1 Correspondence from Mrs. Judy Doré to Mrs. Gail Amyot, July 10, 2012
- APPENDIX 2 Photos
- APPENDIX 3 Sediment physico-chemical analysis results–
2006, 2007, 2011
- APPENDIX 4 Surface samples granulometric analysis results – 2012
- APPENDIX 5 Hydrological analysis of flows in Deception River
- APPENDIX 6 Avalanches hazard assessment
- APPENDIX 8 Certificate of analysis of the SS concentrations - 2012
- APPENDIX 9 Certificate of analysis of the sediment physico-chemical properties– 2012
- APPENDIX 11 Aquatic plants – Underwater photographs
- APPENDIX 12 Requests and responses of the CDPNQ and of the MRNF on the species
at risk in the studied area
- APPENDIX 17 Wharf infrastructures and terrestrial sediment disposal plans
- 17.1 *Permanent wharf*
506117-7000-41-DK-0001, 506117-7000-41-DK-0002,
506117-7000-41-DK-0003, 506117-7000-41-DK-0004
506117-7000-41-DK-0005, 506117-7000-41-DK-0006
506117-7000-41-DK-0007, 506117-7000-41-DK-0008
- 17.2 *Temporary wharf*
533079-8301-0001, 533079-8301-0002
- 17.3 *Sediment disposal site*
101-53046-02_F01, 101-53046-02_F02

LIST OF APPENDICES
VOLUME 2
(CONTINUED)

- APPENDIX 18 Dredge calculation note
- APPENDIX 19 Geochemical testing results
- APPENDIX 20 Photos of the Arctic Class icebreaker
- APPENDIX 21 Common mitigation measures
- APPENDIX 23 Typical environmental monitoring form
- APPENDIX 24 Navigation monitoring protocols

LIST OF APPENDICES
VOLUME 3

- APPENDIX 7 Hydrodynamic modeling of Deception Bay– Sector report
- APPENDIX 10 Characterization of the underwater sound environment - 2012 - Sector report
- APPENDIX 13 Field survey of vascular plant species at risk - Sector report
- APPENDIX 14 Avian fauna - Sector report
- APPENDIX 15 Archeology - Sector report
- APPENDIX 16 Visual integration study - Sector report
- APPENDIX 22 Study on maritime navigation in Deception Bay - Sector report

LIST OF ACRONYMS

Nunavik Inuit Land Claims Agreement	NLCA
Kativik Regional Government	KRG
Canadian Food Inspection Agency	CFIA
Canadian Royalties Inc.	CRI
Centre de données sur le patrimoine naturel du Québec	CDPNQ
Kativik Local Development Centre	KLDC
Federal Environmental and Social Impact Review Panel	FRP-North
Committee on the Status on Endangered Wildlife in Canada	COSEWIC
The Kativik Environmental Quality Commission	KEQC
The Kativik School Board	KSB
Nunavut Wildlife Management Board	NWMB
Kativik Regional Development Council	KRDC
Vulnerable marine ecosystems	VME
Environment Canada	EC
Environmental and Social Impact Assessment	ESIA
Institut national de santé publique	INSPQ
Loi sur la qualité de l'environnement	LQE
Ministère du Développement durable, de l'Environnement et des Parcs	MDDEP
Ministère des Ressources naturelles et de la Faune	MRNF
Kativik Municipal Housing Bureau	KMHB
Fisheries and Oceans Canada	DFO
Higher high water large tide	HHWLT
Ranglan south nickel Projet	RSNP
Nunavik Nickel Project	NNiP
Nunavik Regional Health and Social Services Board	NRHSSB

1. INTRODUCTION

1.1 Setting the Context

The Nunavik Nickel Project (NNiP), headed by Canadian Royalties Inc. (CRI) was the subject of an environmental and social impact assessment (ESIA) (GENIVAR, 2007a), which was filed with the Ministère du Développement durable, de l'Environnement et des Parcs (MDDEP)¹ and transmitted to the Kativik Environmental Quality Commission (KEQC) in April 2007. A certificate of authority for the NNiP was issued on May 20, 2008 under section 201 of the Environment Quality Act (EQA) (RSQ, c. Q-2) (V/Ref.: 3215-14-007).

As part of the 2007 ESIA, five variants were studied in relation to the installation of port infrastructures to be used for shipping copper and nickel concentrate to foundries in Europe. Following analysis of these variants, the Deception Bay site was chosen, considering the configuration of the location and the fact that an existing road is already being used and maintained on the site.

The MDDEP authorized the construction of port infrastructures in 2008 with a certificate of authorization for the NNiP. The Federal Administrator also authorized the work following the recommendation of the Federal Review Panel North (FRP-N). Work began in July 2011 with the preparation of the site. During dredging activities in 2011, a landslide occurred, which required a reassessment of the variants, leading to the production of an ESIA (GENIVAR, 2011). This assessment was submitted to competent authorities in December, 2011, suggesting a new location for the wharf.

In February 2012, federal authorities advised CRI that relocating the wharf would require new public consultations, which could not be completed before the fall of 2012. They also informed CRI that the disposal of dredged sediments at sea was no longer an option favoured by Environment Canada (EC).

In April 2012, FRP-N, EC and Fisheries and Oceans Canada (DFO) sent CRI requests for information on the project as defined in the study of December 2011.

In May, 2012, CRI decided to install port infrastructures on the site already authorized, to do so in two steps in 2013 (a temporary wharf and a permanent wharf), to dispose of the dredged sediments in a designated repository on land, and to immediately advise the relevant authorities of these changes. FRP-N responded by asking for the production of a complete and independent environmental

¹ Ministère du Développement durable, de l'Environnement, de la Faune et des Parcs (MDDEFP) since September, 2012.

assessment on the temporary wharf, the permanent wharf, provisions for capital dredging and maintenance, sediment management, and the choice of a sediment disposal site.

This report responds to the request of FRP-N and to questions and comments formulated in April 2012. It aims to provide all of the necessary information to allow the assessment of the impacts of the port infrastructures and the management of dredged sediments. All of the relevant information and data on sampling records and campaigns in recent years have been put together, particularly in relation to the aquatic environment. The report also includes an assessment of the effects of navigation in Deception Bay.

1.2 Project Justification

The purpose of the project is based primarily on the need to route concentrated nickel and copper, produced by the CRI, from the concentrator on the Expo site to the foundries. The construction of a wharf and warehouse separate from those of Xstrata is essential for the following reasons (already known):

- The Xstrata wharf cannot accommodate two ships simultaneously;
- Since the Xstrata and CRI concentrates do not have the same physical characteristics, they require different loading installations; the concentrate produced by CRI is moister, according to the requirements of purchasing foundries;
- The CRI and Xstrata concentrates may not be stored in the same building due to basic commercial principles.

Although the construction of the port infrastructures was delayed due to the landslide that occurred in July 2011, the construction of the mineral processing plant continued. It will be completed in December, 2012, and the production of nickel and copper concentrates will begin in January 2013. The copper concentrate hall in Deception Bay will therefore be ready to receive ore as of January 2013. This warehouse will have a nominal storage capacity of 53,325 metric tons (mt) of concentrate.

To ensure that the concentrates are well managed in the warehouse and during loading, CRI will build a temporary wharf in the summer of 2013. This wharf will allow the company to empty the warehouse of the concentrate produced in preceding months and to load the ship with as much care as if the permanent wharf were in place. The conveyor and the loading arm of the permanent infrastructure will be installed on this temporary infrastructure. It will be designed to be installed and dismantled quickly, and it will be very stable and reliable. The first shipment of ore, scheduled for August 2013, will be carried out from the temporary wharf.

1.3 Legal and Regulatory Framework

1.3.1 James Bay and Northern Québec Agreement

On November 11, 1975, the James Bay and Northern Québec Agreement (JBNQA) was ratified between the Government of Québec, Hydro-Québec, Société d'énergie de la Baie James, Société de développement de la Baie-James, and the Grand Council of the Cree of Québec and the Northern Quebec Inuit Association. The Government of Canada is also part of the Agreement. The JBNQA is based on two guiding principles, namely that Québec needs to use its resources for the benefit of all of its residents, and that the Government of Québec recognizes the needs of Aboriginal people, both Cree and Inuit.

The territorial regime defined by the JBNQA recognizes three categories of land, covering an area of 1,082 million km². Category I lands are those assigned to each Cree or Inuit community for their exclusive use. They represent 14,348 km² or 1.3 % of the land under agreement. Category II lands constitute a buffer zone where only Aboriginals have the right to hunt, fish, trap, and run outfitters. They represent 159,880 km² or 14.8 % of the land under agreement. Category III lands are public lands on which indigenous peoples may, subject to the principle of conservation, pursue traditional activities year round in addition to having exclusive rights to hunt certain animal species. They represent 907,772 km² or 83.9 % of the land under agreement.

1.3.2 Sanarrutik Agreement

On April 9, 2002, the Government of Québec and the Inuit ratified the Sanarrutik Agreement, inaugurating a partnership on economic and community development. The Agreement is based on the desire to develop the potential of Nunavik while respecting the environment, and on increased responsibility of the Inuit towards their economic and social development. Based on the Paix des Braves Agreement, also negotiated in 2002 between the Government of Québec and the Cree, the Sanarrutik Agreement is in effect for 25 years. It is a complement to the JBNQA and does not change that agreement's foundations.

1.3.3 Environmental assessment process

In accordance with the rules laid down in the JBNQA, Chapter II of the EQA (EQA., c. Q-2) contains specific provisions applicable to the northern regions of Québec. The applicable environmental assessment procedures differ with regards to the active participation of the Cree and Inuit who live there.

For the region north of the 55th parallel, the JBNQA created the KEQC, which is responsible for the preliminary assessment and the review of development projects that fall under provincial jurisdiction. The KEQC is composed of nine members, four of whom are appointed by the Government of Quebec and four by the Kativik Regional Government (KRG). The Quebec government names its president, with the approval of the KRG. The JBNQA created the Kativik Environmental Advisory Committee (KEAC), which monitors the implementation and administration of the environmental protection plan of Section 23 of the JBNQA. This committee is composed of nine members, three of whom are named by the Government of Québec, three by the Government of Canada, and three others by the KRG.

For development projects that fall under federal jurisdiction, the FRP-N is responsible for the preliminary assessment and to make recommendations to the Federal Administrator as to whether or not to authorize a project. The FRP-N is composed of three members appointed by the Government of Canada and two members appointed by the KRG.

Finally, the Nunavik Marine Region Impact Review Board (NMRIRB) was established in 2008 as an institution of public government under the Nunavik Inuit Land Claims Agreement (NILCA) of 2007. This commission determines whether the proposed projects require an examination of the ecosystemic or socio-economic impacts or not. If so, it must then decide, in light of this review, whether or not the projects should be carried out, and if so, under what conditions, and to report its decision to the competent Federal Minister.

1.3.4 Environmental requirements

The Deception Bay port facilities proposal is one of the projects described in Annex A of Chapter 11 of the EQA. That is why this project is subject to an environmental and social impact assessment. The project was authorized by the MDDEP in 2008.

Because of amendments to the Canadian Environmental Assessment Act in 2012, the project is not subject to a federal environmental assessment (Appendix 1. Correspondence from Julie Doré to Gail Amyot, July 10, 2012).

The DFO must issue an authorization under the Fisheries Act (RS, 1985, c. F-14) to allow the deterioration, destruction or disturbance of the fish habitat caused by the construction of permanent infrastructures. A request for modification of the authorization issued in July 2010 by Transport Canada (8200-2006-3001-09-001) under the Navigable Waters Protection Act (RSC, 1985, c. N-22) must be made.

1.3.5 Detailed design of the project

After the environmental assessment process, the design of definitive drawings and specifications (DDS) will be undertaken. In addition to the working methods and mitigation measures set out in this document, the final design will meet applicable standards with regard to the projected equipment and infrastructures. The DDS should, where appropriate, be subject to an assessment and permit applications under the laws and regulations enacted by the governments of Canada and Quebec.

2. STUDY AREA

2.1 Generalities

The study area encompasses all of Deception Bay, including the sites studied for the port infrastructures (Q1 and Q2) and dredged sediment disposal sites (4, A, B, C, D and E). It also includes part of Deception River and its estuary and Lake Duquet to the south, and extends to Pointe-Noire to the north (map 2.1 and Appendix 2).

The study area is approximately 23 km long and 5 km wide. It covers an area of approximately 105 km² and lies between latitudes 62°01'N and 62°12'N and longitudes 74°29'W and 74°49'W. These boundaries provide a framework for the main effects of the port infrastructures, the land disposal site and navigation on different components of natural and human environments, such as sediment quality, marine organisms and the Inuit's use of land for traditional purposes.

As needed, this study area is enlarged or adjusted to include elements relevant to the description of the environment or the environmental impact assessment.

2.2 Port and Navigation Infrastructures

2.2.1 Port infrastructures

The central geographical coordinates of site Q1 and site Q2 are given below (map 2.1).

Site Q1

- 62° 08' 23" latitude north;
- 74° 41' 03" longitude west.

Site Q2

- 62° 08' 09" latitude north;
- 74° 40' 10" longitude west.

2.2.2 Navigation

The navigation study area includes the maneuvering area for ships around the wharf site, and the portion of Deception Bay located northwest of the wharf up to Pointe-Noire.

2.3 Land Disposal Site and Access Road

The land disposal sites studied are shown on map 2.1. Their central geographical coordinates are as follows:

Site A

- 62° 08' 03" latitude north;
- 74° 40' 26" longitude west.

Site B

- 62° 07' 48" latitude north;
- 74° 39' 49" longitude west.

Site C

- 62° 07' 35" latitude north;
- 74° 39' 44" longitude west.

Site D

- 62° 07' 17" latitude north;
- 74° 39' 42" longitude west.

Site E

- 62° 07' 19" latitude north;
- 74° 40' 16" longitude west.

Site 4

- 62° 06' 07" latitude north;
- 74° 35' 30" longitude west.

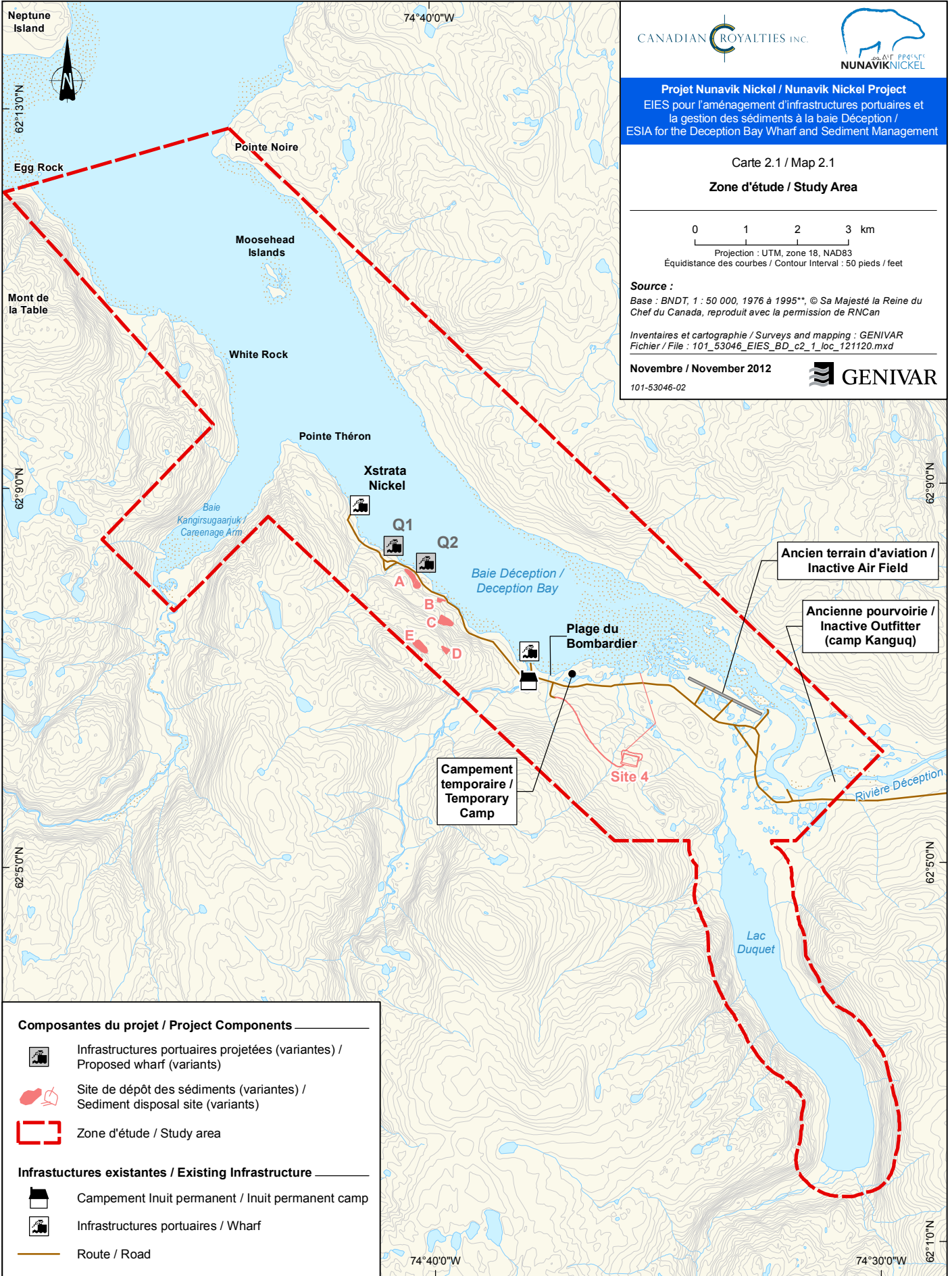

Projet Nunavik Nickel / Nunavik Nickel Project
 EIES pour l'aménagement d'infrastructures portuaires et la gestion des sédiments à la baie Déception / ESIA for the Deception Bay Wharf and Sediment Management

Carte 2.1 / Map 2.1

Zone d'étude / Study Area





Projection : UTM, zone 18, NAD83
 Équidistance des courbes / Contour Interval : 50 pieds / feet

Source :
 Base : BNDT, 1 : 50 000, 1976 à 1995**, © Sa Majesté la Reine du Chef du Canada, reproduit avec la permission de RNCan



Inventaires et cartographie / Surveys and mapping : GENIVAR
 Fichier / File : 101_53046_EIES_BD_c2_1_loc_121120.mxd

Novembre / November 2012 
 101-53046-02

Composantes du projet / Project Components

-  Infrastructures portuaires projetées (variantes) / Proposed wharf (variants)
-  Site de dépôt des sédiments (variantes) / Sediment disposal site (variants)
-  Zone d'étude / Study area

Infrastructures existantes / Existing Infrastructure

-  Campement Inuit permanent / Inuit permanent camp
-  Infrastructures portuaires / Wharf
-  Route / Road

Ancien terrain d'aviation / Inactive Air Field

Ancienne pourvoirie / Inactive Outfitter (camp Kanguq)

Campement temporaire / Temporary Camp

Plage du Bombardier

Site 4

Lac Duquet

Baie Déception / Deception Bay

Baie Kangirsugaarjuk / Careenage Arm

Xstrata Nickel

Pointe Théron

White Rock

Moosehead Islands

Egg Rock

Mont de la Table

Neptune Island



74°40'0"W

62°13'0"N

62°00'0"N

62°50'0"N

62°00'0"N

62°50'0"N

74°40'0"W

74°30'0"W

62°10'0"N

3. DESCRIPTION OF THE PROJECT'S VARIANTS

3.1 Port Infrastructures

3.1.1 Generalities

On September 4, 2006, sediment sampling took place in the vicinity of each of the three potential wharf sites being studied. Site Q1 was being considered at that time, and special attention was paid to the data that came from this site.

In 2011, sediment sampling was conducted on site Q2, since by then, this site was being considered as the wharf site. Drilling work, carried out as part of the Stantec geotechnical study, took place in September 2011. A total of 13 drilling operations were performed in the sediments of site Q2.

The substances analyzed and the criteria considered in 2006 and 2011 can be found in Tables 1 and 2, available in Appendix 3. The maps showing the sampling points are also presented.

Thus, in light of test results obtained between 2006 and 2011, and considering the comments received in the analysis report submitted in December 2011, sites Q1 and Q2 were the subject of complementary investigations in the summer of 2012. Site Q1 could once again be considered as a location for the port infrastructures due to major changes to the design concept.

It is important to note that site Q1 was different after the events that occurred on July 11, 2011. During construction of the wharf, a landslide occurred to the right of the construction site. The event took place over a few hours. An estimated volume of 16,000 m³ of boulders (all from blasting) had been put in place to build the pier. The landslide occurred because of the seabed's unsuspected resistance to puncturing. The stone did not penetrate the adjacent clay as expected. Also, the unsuspected presence of a layer of soft and sensitive clay was also a cause; the weight of the fill surpassed the clay's shear strength, resulting in the collapse of the clay and the subsequent landslide. No corrective work has been done to date.

3.1.2 Comparative analysis of variants

Both variants (sites Q1 and Q2) were compared according to environmental and technical criteria. The comparative analysis of the sites was done considering that a floating wharf would be built in both cases. Since these two sites were located less than 800 m from each other, the environmental impacts associated with the construction and operation of these sites would be similar.

A score ranging from 1 to 3 was given to each criterion for each site, 3 being the best option and 1 being the worst. The criteria were considered equivalent to each other. The variant with the best score was chosen, with a maximum possible score of 18.

Site Q1 proved to be the most advantageous, with a score of 14 (Table 3.1).

3.2 Management of Dredged Sediments

Two options are available for the management of dredged sediments: sea disposal and land disposal. The environmental assessment report of December 2011 (GENIVAR, 2011) provided for sea disposal and suggested four sites in Deception Bay. However, various criteria for selecting the management method were reassessed in light of new analyses of technical and environmental data, and as a result of comments received from various stakeholders, including federal authorities.

Sea disposal was therefore discarded as a management method for the following reasons:

- When sea disposal was considered as a management method, the volume of dredged sediments was estimated to be high, which posed major technical and environmental challenges for their management on land;
- The hydrodynamic conditions of Deception Bay (GENIVAR, 2012) are such that there is a significant risk of creating sediment plumes during sea disposal operations, which would take time to dissipate (in addition to the plume created by the dredging itself), and could affect marine wildlife and some sensitive habitats, such as the estuary of Deception River under certain weather conditions (especially winds from the northwest);
- Inventories made on one of the sea disposal sites studied show the probable presence of soft corals, which suggests their presence in all of the sea disposal sites studied. These organisms form vulnerable marine ecosystems (VME), which Canada is committed to protecting by supporting Resolution 61/105 of the United Nations General Assembly of 2006 on fishing activities and the protection of VME;
- The DPO asked that before considering sea disposal, all other land disposal options be considered;
- The time required for the recolonization of benthos in an Arctic sea disposal site is unknown;
- Sea disposal in Deception Bay has a significant risk of disturbing the marine mammals that live there, especially the beluga, which carry out breeding activities in the bay;
- The frequent round-trip traffic of the barges transporting sediments between the dredging and disposal sites also poses a risk of collision with marine mammals.

Table 3.1 Analysis of Variants – Port Infrastructures

	Site Q1	Score	Site Q2	Score
Environment				
E1 – Effect on ichthyofauna	Average	2	Average	2
E2 – Effect on marine flora	Average Site disturbed after the landslide of 2011	2	Strong	1
E3 – Effect on benthos	Average	2	Average	2
Technical				
T1 – Proximity to the concentrate hall	Opposite concentrate hall	3	850 m from concentrate hall Requires the installation of a conveyor above the trajectory of the avalanche corridor	1
T2 – Authorization process	Site authorized at CA global	3	Modification of CA global required	1
T3 – Trajectory of the avalanche corridor	The wharf infrastructures could be affected by sediments caught up in the spill resulting from a landslide	2	Little risk of the wharf being affected	3
Total		14		10

Note: Must be read with map 7.1- General layout

3.3 Disposal Sites for Dredged Sediments

3.2.1 Generalities

The management site for dredged sediments on land must be set up as closely as possible to port infrastructures to minimize sediment transport between the excavation site and the storage site.

During the preparation of the environmental assessment in December 2011, four potential sites were identified and analyzed on the basis of information available on the topographical maps, namely sites 1-4.

In the summer of 2012, a site visit was conducted by a team from GENIVAR Inc. (GENIVAR) comprising an engineer, biologists and a botanist to locate potential new sites and to make an inventory to determine which site would have the fewest environmental issues. Sites A to E were then identified

The following sections draw a general portrait of these sites and present a comparative analysis.

3.2.2 Description and location of sites 1 to 4

Site 1 was to be installed on the wharf built in the fall of 2011 in the context in which port infrastructures (wharf and ore concentrate hall) were to be built on site Q2. However, in the summer of 2012, it was decided to build the concentrate hall according to what had been presented in the 2007 ESIA and authorized by provincial authorities. Thus, site 1 could not be considered as a potential site for the management of dredged sediments.

Scenario 2 consisted of building a basin behind the concentrate hall then proposed on site Q2. This scenario was not chosen due to the fact that excessive blasting would be required.

Site 3 was located to the east of the petrol station and was to be built on the side of the hill, south of the existing road. The concept proposed in March 2012 also included the blasting of a large amount of rock. In addition, a survey done in this sector by Golder and Associates in December 2008 revealed a deep layer of clay. It was therefore considered preferable to avoid this area and not to consider site 3 as a potential sediment management site.

Site 4 was the most remote of the 4 proposed sites, about 7 km from Q1. To get there, a road of about 1.5 km in length would have to be built from the existing road. Of all of the sites proposed in the spring of 2012, only site 4 was considered as a potential sediment management site for the purpose of this environmental assessment.

3.2.3 Description and location of sites A to E

Apart from site 4, five other potential sites for the management of dredged sediments were included in field surveys in the summer of 2012. Map 2.1 shows the location of each site.

Site A is located opposite the petrol station, on the south side of the existing road. About 262,000 m³ of rock originating from blasting operations conducted in the summer of 2010 is currently stored there. This site is approximately 650 m from site Q1.

Site B is also located along the existing road, southeast of Site A and about 1.3 km from the proposed port infrastructure. However, due to the small area available, a large amount of rock would have to be blasted to create a hole big enough to hold the volume of dredged sediments.

Sites C, D and E are located on the hill along Deception Bay to the southwest, in hollows of the existing terrain. These sites form natural holes requiring minimal blasting. However, the construction of access roads is required for each of these sites. The approximate length of these roads is 0.3 km for site C, 1.4 km for site D and 1.8 km for site E.

3.2.4 Comparative analysis of variants

These six variants (sites 4, A, B, C, D and E) were compared according to environmental and technical criteria. A score ranging from 1 to 3 was given to each criterion for each site, with 3 being the best option and 1 the worst. The criteria were considered equivalent to each other. The variant with the best score was retained, the maximum score being 36.

Site A proved to be the most advantageous, with a score of 35.

Table 3.2 presents the analysis of the scenarios.

Table 3.2 Variance analysis - Terrestrial sediments deposit

Preliminary document Sediment volume estimated at 50 000 m ³	Site 4	Score	Site A	Score	Site B	Score	Site C	Score	Site D	Score	Site E	Score
Environnement												
E1 - Impact on wildlife and marine	High Migratory corridor for caribou	1	Low	3	High Blasting required near the bay	1	Medium, potential migratory corridor for caribou	2	Medium, potential migratory corridor for caribou	2	High, potential migratory corridor for caribou and presence of a freshwater body	1
E2 - Species at risk: wildlife and vegetation	None	3	None	3	None	3	Suitable site for the establishment of species at risk	2	Suitable site for the establishment of species at risk	2	Presence of a falcon nest	1
E3 - Impact on vegetation	Low Relatively bare ground	3	Low Relatively bare ground and disturbed area	3	Medium Well-developed vegetation cover	2	Medium Small slope ground, Well-developed vegetation cover, presence rocky hillside	2	Medium Small slope ground, Well-developed vegetation cover, presence rocky hillside	2	Medium Small slope ground, Well-developed vegetation cover, presence rocky hillside	2
E4 - Archaeological potential	High, sensitive environments due to the presence of a protected archaeological site	1	Low	3	Low	3	Low	3	Low	3	Low	3
E5 - Visual integration to landscape	Integration to the landscape is difficult because it's visible from a great distance	1	Easy integration to the landscape	3	Visual breakthrough from Inuit camps	2	Site dissimulated but access road partially visible	2	Site dissimulated but access road partially visible Presence of inuksuit (2) possibly used by the Inuit as ATV or snowmobile trail tag	2	Site dissimulated but access road partially visible	2
E6 - Air quality, acoustic environment (Inuit camp distance from the Bombardier beach)	2.5 km	3	2.8 km	3	2.3 km	3	2.0 km, access road at 1.65 km	2	1.7 km, access road at 0.5 km	2	2.1 km, access road at 0.5 km	2
E7 - Road safety - risk of accidents related to transportation	Longer route The highest risks	1	Shortest route Lowest Risks	3	Relatively short route Relatively low risks	3	Medium length route Medium risks	2	Long route, significant slopes High risks	1	Longest route, significant slopes High risks	1
Technical												
T1 - Accessibility, roads	Route with a length of the order of 1.5 km to construct		Easy access	3	Easy access	3	Route with a length of the order of 0.3 km to construct	2	Route with a length of the order of 1.4 km to construct	1	Route with a length of the order of 1.8 km to construct	1
T2 - Ownership, leases	Off lease CRI	1	On lease CRI	3	Off lease CRI	1	Off lease CRI	1	Off lease CRI	1	Off lease CRI	1
T3 - Water management	A collection system and a conduit must be designed to concentrate and channel the dike resurgent water towards Deception Bay, environments rich in plant species must be avoided	1	Low	3	Low	3	A collection system and a conduit must be designed to concentrate and channel the dike resurgent water towards Deception Bay	1	A collection system and a conduit must be designed to concentrate and channel the dike resurgent water towards Deception Bay	1	A collection system and a conduit must be designed to concentrate and channel the dike resurgent water towards Deception Bay	1
T4 - Blasting	Required for the construction of retention dykes, remote from the bay	2	None	3	Required to create a pit due to the limited space available, site located near the bay	1	Required to increase the depression and for the dikes construction, remote from the bay	2	Required to increase the depression and for the dikes construction, remote from the bay	2	Required to increase the depression and for the dikes construction, remote from the bay	2
T5 - Approximate area affected by the construction (site and road)- m ²	17 500 m ²	1	47 900 m ²	2	10 340 m ²	1	44 260 m ²	2	16 840 m ²	1	44 650 m ²	2
Total		18		35		26		23		20		19

Note: Must be read with map 2.1 - Study Area

4. SCOPE OF THE ENVIRONMENTAL ASSESSEMENT AND CONSULTATIONS WITH THE INUIT

4.1 Scope of the Environmental Assessment

The environmental assessment focuses on the structures, work and activities listed below (the project):

- The temporary and permanent port infrastructures (wharf) and the related facilities and work, including dredging;
- Ore transshipment activities from the concentrate hall to the ships;
- Navigation required to transport concentrated nickel and copper to overseas processing plants and the supply of goods, materials and petroleum products;
- The construction of a land disposal site;
- The transportation of dredged sediments and their disposal.

The construction, operation, maintenance and modification phases are covered. When CRI mining activities come to an end in the area, the port infrastructures will be given to the regional government for its own needs.

The components of the physical, biological and human environments of Deception Bay that could be affected by the project are included in the environmental assessment.

Emphasis is placed on components highlighting the socioeconomic or ecosystemic point of view. These components are:

- Marine mammals;
- Land use by the Inuit for traditional purposes.

The report is accompanied by five sectorial reports, which are presented in the Appendix. They cover the following topics:

- Hydrodynamics (Appendix 7);
- The underwater sound environment (Appendix 10);
- Threatened or vulnerable vascular plant species (Appendix 13);
- Avifauna (Appendix 14);
- Archeology (Appendix 15);
- Landscape (Appendix 16).

4.2 Public Consultations and Other Meetings with Stakeholders

This section presents a summary of the public consultations and meetings organized by the CRI with various stakeholders on the construction of the mining complex and the port installations in Deception Bay, held since 2006.

Since 2002, CRI has periodically met with the KRG, the Makivik Corporation and several other groups and decision makers from the Inuit villages most affected by the NNiP. Table 4.1 presents the dates, places and stakeholders that were met, and the topics discussed or addressed between August 2008 and October 2012.

In 2006, consultations on the NNiP as a whole took place in the communities of Salluit, Kangiqsujuaq and Puvirnituk. The results of these consultations are summarized in section 4.2.1. Public meetings and private interviews were held in the spring of 2012 by EEM Inc., consultant on corporate environmental and social responsibilities (section 4.2.2.). Section 4.2.3 summarizes the most recent meetings held in September 2012 in the communities of Salluit and Kangiqsujuaq.

The majority of the requests and concerns of participants in the public consultations were taken into account by CRI. The Nunavik Nickel Agreement, signed in 2008 by CRI, the Landholding Corporation of Nunaturlik in Kangiqsujuaq, the Landholding Corporation of Qarqalik in Salluit and the village of Puvirnituk, provides a set of provisions relating to socioeconomic benefits (jobs, training contracts, etc.) and financial compensation. It also led to the establishment of a liaison committee which is a place for discussion between the signatories. Its members make sure the agreement is implemented. CRI conducts follow-ups on over 30 components of the NNiP and the environment, which aim to ensure the effectiveness of measures implemented to minimize the negative effects of the project and to provide corrective measures, if needed.

Since November 2011, a monthly report about the activities and the performance in environment and health and safety at work has been sent to KRG representatives, the Landholding Corporations of Qarqalik and Nunaturlik, the villages of Salluit, Kangiqsujuaq and Puvirnituk, and the Makivik Corporation.

Table 4.1 Summary of meetings between CRI and stakeholders – August 2008 to October 2012

Date	Place	Stakeholders	Subject(s) discussed
August 2008	Kangiqsujuaq	<ul style="list-style-type: none"> Nunavik Nickel Liaison Committee 	<ul style="list-style-type: none"> Announcement of the temporary closure Update on the search for financial partners and the process of cleaning up the historical sites (FRAN)
June 2009	Montréal	<ul style="list-style-type: none"> Nunavik Nickel Liaison Committee 	<ul style="list-style-type: none"> Presentation of new partners and reiteration of the signing of the IBA
December 2009	Kuujuuaq	<ul style="list-style-type: none"> Nunavik Nickel Liaison Committee 	<ul style="list-style-type: none"> Contracts with Inuit firms Jobs and subsidies that could be granted for social activities in the communities
July 2010	Signatory villages and Kuujuuaq	<ul style="list-style-type: none"> Inuit from the signatory villages of the Nunavik Nickel Agreement 	<ul style="list-style-type: none"> Update on the progress of permits and work, presentation of upcoming work. Cancelled due to bad weather
September 2010	Expo	<ul style="list-style-type: none"> Nunavik Nickel Committee 	<ul style="list-style-type: none"> Update on information about concerns, comments and questions from the different communities
December 2010	Signatory villages	<ul style="list-style-type: none"> Nunavik Nickel Committee 	<ul style="list-style-type: none"> Definition of workforce needs and training programs provided by CRI Project progress
February-March 2011	Expo and Signatory villages	<ul style="list-style-type: none"> Nunavik Nickel Liaison Committee Inuit from the signatory villages of the Nunavik Nickel Agreement 	<ul style="list-style-type: none"> Project progress, work completed and to come Problems encountered in the summer of 2011 Process of awarding contracts Training program
May 2011	Montréal	<ul style="list-style-type: none"> Nunavik Nickel Committee 	<ul style="list-style-type: none"> Project progress Problems encountered in the summer of 2011 Causes and consequences of the event at the port site
October 2011	Puvirnituq	<ul style="list-style-type: none"> Nunavik Nickel Committee 	<ul style="list-style-type: none"> No quorum – update on work and EHS performance Public presentations with question periods and discussions
March 2012	Expo site	<ul style="list-style-type: none"> Nunavik Nickel Committee 	<ul style="list-style-type: none"> Radio program Reception of job applications Private meetings with community leaders and other people to draw up a stakeholder map
March and May 2012	Signatory villages	<ul style="list-style-type: none"> CRI team Inuit from the signatory villages of the Nunavik Nickel Agreement (≈ 50 pers./village) 	<ul style="list-style-type: none"> Members of CRI management Leaders of villages and landholding corporations Stakeholders from KRG in environment and renewable resources
July 2012	Salluit and Kangiqsujuaq	<ul style="list-style-type: none"> Member of CRI management Leaders of villages and landholding corporations Stakeholders from KRG in environment and renewable resources 	<ul style="list-style-type: none"> Presentation of the port infrastructure construction project to receive comments
September 2012	Salluit and Kangiqsujuaq	<ul style="list-style-type: none"> Member of CRI management Leaders of villages and landholding corporations 	<ul style="list-style-type: none"> Revised wharf project (new concept to be built in 2013) Presentation of the report on the stakeholder consultation
October 2012	Montréal	<ul style="list-style-type: none"> Meeting with representatives of signatories of the Nunavik Nickel Agreement 	<ul style="list-style-type: none"> Among other things, presentation of the port infrastructure construction project to receive comments

4.2.1 Public consultations carried out by the CRI in 2006 in Salluit, Kangiqsujaq and Purvinituq

Public consultations were held from July 31 to August 12, 2006 in the villages of Puvirnituk, Salluit and Kangiqsujaq. The groups that were met during these consultations were composed of members of municipal councils, landholding corporations, and the boards of directors of three village cooperatives.

In Salluit, a focus group composed of village residents was formed, and some other people were interviewed individually. In Kangiqsujaq, a local radio program was broadcast to introduce the NNiP to the population. The villagers were then asked to call in and share their concerns and expectations in relation to the project. A total of 13 people participated in the radio program. Some organizations, such as the Makivik Corporation and the Association of Nunavik Landholding Corporations were met in Kuujjuaq.

The meetings were conducted in English and discussions were translated, for the most part, into Inuktitut. On average, the duration of a meeting was two hours. All meetings began with an overview of the project, including the location and description of the major mining infrastructures. This presentation was then followed by discussions, mainly about the public's concerns and expectations about the project.

The main objective of the meetings was to discuss the stakeholders' various concerns and expectations regarding the NNiP and the use of land and resources by the villagers of Salluit and Kangiqsujaq. Affected populations also expressed their positive or negative experiences with the Raglan project.

These consultations sometimes led to discussion on mitigation and compensation measures that could be considered throughout the implementation of the project.

4.2.1.1 Concerns raised

The concerns and expectations raised by stakeholders are grouped around the different themes that were discussed at the meetings. In 2006 and 2007, the majority of discussions focused on the mine site and concerns about Deception Bay.

Access to Employment and Training

Hiring

Participants expressed specific concerns about the fact that hiring priority could be given to workers from the south. A sense of injustice was also reported with regards to the employment priority given to residents of Salluit and Kangiqsujaq. It was also mentioned that Inuit employees have faced discrimination.

Several participants mentioned that the hiring of Inuit employees should be maximized. They believe that it is advantageous to promote the hiring of Inuit, in particular because of their adaptability to the North, which is a harsh environment.

Some stakeholders mentioned that it was preferable to offer jobs to the whole population of Nunavik, without granting priority to certain villages, although a precedent was set with agreements relative to the Raglan mine, which prioritized the villages of Salluit and Kangiqsujaq for hiring workers. Thus, according to stakeholders from Salluit, jobs should first be offered equitably to the villages of Salluit and Kangiqsujaq, and then to the other villages of Nunavik. In light of other mining projects, people feared that unionizing the mine would put the Inuit at a disadvantage in terms of hiring. Workers from the south usually have more experience, which, the participants thought, could affect the Inuit. Participants said that they hoped their work experience and their skills would be recognized for hiring purposes.

The people from Salluit said they feared that the jobs being offered to them only applied to goods and services at the mine, such as cleaning, cooking, etc. They hoped to have the opportunity to get jobs in the goods and services sector, but also in more specialized sectors, such as heavy machinery.

According to some participants, the CRI may have trouble finding Inuit employees ready to work in the mine, since many already work or have worked at the Raglan mine and have said they would not be ready to do this type of work again and experience the same conditions. To facilitate the hiring of Inuit, offering better working conditions, such as short rotation periods, was suggested. However, according to some stakeholders from Kangiqsujaq, young people were more interested in working in the new mine. It was also mentioned that employees who had been fired from the Raglan mine should have a second chance of being hired at the new mine.

Training programs

Since education is an important issue, some stakeholders indicated that mining activities should be part of secondary school training. Students could visit the mine and find out about work opportunities for the future.

It was noted that training programs in partnership with the Kativik School Board (KSB) should be created. A variety of stakeholders suggested that the training programs should be relatively short and focused on training in the workplace in order

to keep the young students motivated. In addition to training programs, it was noted that summer jobs should be offered to young students to motivate them to continue their studies. Advertising campaigns could also contribute to motivating the young people to finish high school, continue their studies and then work at the mine.

Finally, it was reported that well before the beginning of the construction phase, a list of typical jobs available should be distributed in the villages so the young people could begin their training as early as possible in order to be ready for the mine opening.

Labour relations

Like what happened in other mining projects, people expressed concern in 2006 that labour relations would be difficult between employees from the south and the Inuit. They anticipated competition for jobs, fearing that the employees from the south, not wanting to lose their jobs to the Inuit, would exhibit discriminatory behavior.

A cultural exchange program with the employees was suggested by participants in order to explain the Inuit cultural context and its values, and provide information on traditional customs. This type of program had already been implemented at the Raglan mine and was considered very positive. Participants in the 2006 consultations also suggested that a liaison agent be hired to manage conflicts and promote understanding between workers from the south and the Inuit.

Turnover

According to different stakeholders, the high turnover rate for Inuit employees at the Raglan mine could be partially due to difficult labour relations. This phenomenon was attributed to the fact that the Inuit are very close to each other and that when a negative event happens in the community or one person has a problem, all of the community members are affected. They then tend to leave their jobs to be closer to their people.

Effect of job creation on the villages

Comments on the positive or negative effects of jobs created in the Inuit villages were discussed.

According to some, job creation in the villages could contribute to increasing social problems, such as alcohol and drug abuse, since people would have more money to spend. Others felt that job creation could contribute to reducing social problems because people are busy working.

Some believe that job creation will stimulate the local economy and bring more money into the villages. This improvement to the local economy will allow a greater variety of products to be offered to the population.

4.2.1.2 Business opportunities and the local economy

Companies

Most stakeholders expressed the fear that the majority of contracts related to the project would be granted to companies in the south. They feared that Rouyn-Noranda would be the city that would benefit most from the project, as was the case for the Raglan mine.

Stakeholders from Puvirnituk and Salluit noted that there are several companies in these two villages, and in all of Nunavik, which could meet the mine's various needs (diesel supply, construction of workers' camps and building maintenance, air transport, heavy machinery operation, etc.). New companies could also be created to produce energy (hydraulic or wind). It was also mentioned that all of the goods and services provided to the mine could come from Salluit companies. It was recalled that the contracts should be offered to the private sector and not only to landholding corporations or to the Makivik Corporation. Several stakeholders thought it essential to choose local companies for mine contracts, especially those that are 100% owned by Inuit, as stipulated in the JBNQA.

Involvement and Investments

Residents of the villages of Puvirnituk, Salluit and Kangiqsujuaq said they wanted to be involved in the project and some were even interested in being on the board of directors. Several stakeholders also showed interest in making corporate and private investments in the mining company.

Benefits and Royalties

Residents of the villages of Salluit and Kangiqsujuaq said they expected to receive significant royalties. They would like to obtain more benefits than in the context of the Raglan mine.

The Inuit of Salluit said they were ready to negotiate. According to them, it would be more profitable for the community to accept the arrival of such a project and to negotiate benefits and royalties to compensate for the impacts. The negotiations should involve the population, rather than just the municipal council and the

landholding corporation. The people of Salluit fear that the benefits and royalties received by the new mining project will not be collected by the landholding corporation.

Members of the Kangiqsujuaq community would like to have a greater part of the royalties than the village of Salluit, since they believe that their community will be more affected by the project. They would also like the royalties received to be distributed to the families to counteract poverty, instead of investing the money in village infrastructures.

Others felt that the royalties should be offered equally to all of the villages in Nunavik. No priority should be granted to the villages of Salluit and Kangiqsujuaq. However, according to the Makivik Corporation, since a precedent was set with the Raglan mine favouring the villages most affected by the mine (Salluit and Kangiqsujuaq), it would be very difficult to proceed otherwise and involve all of the villages in Nunavik equally for the new mining project.

Finally, in light of other mining projects, people fear that certain aspects that were negotiated or agreed upon with the mining company will end up being forgotten and not respected.

Opportunities for the Local Economy

The arrival of a new mine is perceived by most of the people who were met as a project promoting job creation and offering good opportunities, especially for young people.

Instead of providing air transportation to the mine for employees from Salluit, the people of Salluit would prefer a road to be built between Salluit and Deception Bay. According to the stakeholders who were met, this road would have several advantages. For example, it could:

- Allow villagers to get to work at the mine more easily;
- Allow workers to go back to their villages more often;
- Reduce the village's costs for food supplies, construction equipment and heavy machinery for the village;
- Allow people to travel more easily to their hunting and fishing areas;
- Promote tourism in the village by making it more accessible;
- Promote opportunities for creating new businesses.

Kangiqsujuaq stakeholders also suggested that a road be built between Wakeham Beach and the new mine. This road would be useful to mine employees who live in Kangiqsujuaq, and also to tourists who wish to visit Parc national des Pingualuit. The new mine could thus contribute to promoting tourism. Tourists could even include a visit to mine infrastructures in their tour.

Kangiqsujuaq stakeholders said they would like CRI to build a wharf at Douglas Harbour instead of Deception Bay.

4.2.1.3 Environmental impacts and impacts on the practice of traditional activities

Participants mentioned that nowadays, mine projects must respect the environment to be allowed to continue their activities. They expect that the permit application process will be respected to ensure that the environment is adequately protected.

People hope that the promoter will learn from errors that occurred at the Raglan mine, especially in terms of the management of mining residues (dust that can affect the quality of the water) and accidental spills.

According to some stakeholders, an open-pit mine is much more damaging to the environment than an underground mine. Necessary measures to protect the environment must be taken. The main concerns about the effects of the mine on the environment are related to a change in water quality, potential contamination of fish, a change in air quality, potential contamination of caribou meat, and changes to the population's hunting and fishing activities.

Change in Water Quality

Several stakeholders feared that mine tailings and mining activities in general affect the quality of water in the rivers and lakes. According to participants, water quality should be monitored in the waterways affected by the project before the project begins, and until the mine closes.

Potential Contamination of Fish

Stakeholders feared that changes in water quality could lead to contamination of migrating fish in the rivers.

The people of Kangiqsujuaq fear that mining will have effects on fish populations, since for several years, dead fish have been seen in the Wakeham Bay River. At Wakeham Beach, dead crustaceans were also found on the coast. People question

the connection between these events and current mining activities. It is hoped that an environmental monitoring program of fish populations in the waterways affected by the project will be conducted to ensure that fish are not contaminated and that this contamination does not accumulate in people who eat the fish.

Changes in Air Quality Due to Dust

Air quality is also a concern. People fear that mine tailings will be dispersed by the wind and snow and that they will affect the natural environment. To limit the dispersal of mine tailings, it is proposed that they be converted into sand and gravel and placed in a strategic location, determined by the direction of dominant winds.

In Kangiqsujuaq, the population is concerned about air pollution because yellow and brown clouds are sometimes seen in the sky over the bay. People wonder if these clouds are related to mining activities.

A monitoring program on snow quality in Parc national des Pingualuit is suggested, since mine tailings are very fine and can be carried by the wind and snow over long distances.

It was noted that the use of the road in the Deception Bay and Lac Watts area created more dust, which can affect the environment.

Paving the road has been suggested as a mitigation measure. Transporting ore in closed trucks was also suggested. It was found that a canvas covering was not enough to prevent the dispersal of ore concentrate.

Potential Contamination of Caribou Meat

Several stakeholders who were met feared that the contamination of the environment by mine tailings could affect caribou meat.

A monitoring program on the quality of caribou meat was suggested to make sure that it is not contaminated or that this contamination does not accumulate in people who eat caribou meat.

Other Environment-Related Concerns and Expectations

- The people of Kangiqsujuaq mentioned that the water reservoir seemed to be located in a shallow stream and in a topographical area that would not hold water. This spot did not seem like the best place for a reservoir.

- The importance of concluding a long-term agreement between Xstrata Nickel and CRI for the use of existing port infrastructures was mentioned several times. Several stakeholders thought it would be preferable to consider the use of existing infrastructures to minimize impacts on the environment.
- The Makivik Corporation also underscored that in Nunavik nearly 600 abandoned mining exploration sites continue to pollute the environment.

Some stakeholders suggested that during the construction phase, the incinerator and water treatment plant should be built first. A recycling process (tires, used oil, etc.) should be established early in the project. In addition, on the construction sites, vehicle engines should be turned off when the vehicles are not running. Finally, it was reported that all buildings should be properly insulated to minimize heat loss.

- Stakeholders from Salluit and Kangiqsujaq expect impacts on the landscape to be minimized by restoring the affected areas as much as possible. They believe that the rehabilitation of mine sites should begin as soon as the mine is closed, by filling the mine pits with sterile tailings to return the sites to their original state.

4.2.2 Consultation with communities, stakeholders and regional representatives – spring 2012

The consultation activities carried out by the MES took place from March 19 to 23, and May 22 and 23, 2012 in the communities of Kangiqsujaq, Salluit and Puvirnituq. They also involve Inuit workers from the mine. These activities include public meetings, individual meetings with stakeholders (government, local, landholding corporations, healthcare, economic and environmental), a radio program (in Kangiqsujaq) and telephone interviews with a variety of regional representatives.

Participants in the public meetings were invited to share their main concerns about the NNiP and its impacts. They are summarized below:

- Water: wastewater treatment (at the mining facilities and those of Deception Bay), proximity of the petroleum station to Deception Bay, effects on snowmelt during the hunting season.
- Air: dust generated by mining activities and the discharge of polluting particles into the air during blasting.
- Wildlife: the impacts of mine tailings (mercury) on the quality of water and fish and on the birds that frequent the settling ponds, the health of animals in general, and changes in migration routes (caribou).
- Parc du Pingualuit: general impacts on its environment and on tourism.

- Land use: impacts on relations with the land its use due to fears of contamination, impacts on subsistence activities near the mine and navigability near the Deception Bay pier (partially collapsed).
- Inuit workers: racism, stress, language problems, tensions between the Inuit, difficulty contacting families from the mine.
- Health problems related to the influx of money in the communities: drug and alcohol abuse, violence, pressure on social services, corruption.
- Economy: sharing monetary compensation and economic benefits for too short a time.
- Employment: Poor quality jobs, insufficient training to allow access to better jobs, inadequate hiring, dismissal without notice.
- Positive impacts: jobs generated by the mine encourage people with drug and alcohol problems to regain control, local hiring, benefits related to monetary compensation.

The stakeholders and the regional representatives interviewed were invited to make recommendations on the management of various aspects of the project, to express the needs of the communities and the challenges they face, and to give their advice as to the role mining companies should play in their development.

Recommendations on the management of the project were based on:

- The involvement of the Inuit in environmental management (impact assessment and monitoring);
- The location of port infrastructures;
- Opportunities for fish compensation projects;
- Mitigation measures affecting wildlife;
- Employment, work conditions and training;
- The development of better collaboration between the CRI and the Inuit;
- Economic benefits for communities.

The following needs and challenges of the communities were raised:

- Social problems: drug and alcohol abuse, high crime rates, population growth.
- Culture: loss of traditional knowledge and methods.
- Infrastructures: housing shortages, overcrowded houses, lack of public meeting places and infrastructures in general (Salluit and Puvirnituk).
- Economy: cost of transporting goods and people, job creation and training programs.

The proposals made by the stakeholders and regional representatives on the role that mining companies should play on community development:

- Provide support in resolving social problems, the development of public infrastructures (swimming pools, meeting places) and the construction of housing.
- Education: establish a fund to help people get an education (bursaries) in the mining sector, help develop education infrastructures (college), sponsor and support summer and science camps.
- Participate in the construction of roads between Kangiqsujuaq and the mine and between Salluit and Deception Bay.

Finally, participants in the consultations had the opportunity to express their opinions on the exercise they were invited to participate in, and their ideas on the follow-up that the CRI should provide. In general, participants expressed their satisfaction with the consultation and said they hoped that greater efforts would be made to better inform communities about the project (using the wide range of tools available). They also said that they wanted to be more involved.

4.2.3 Meetings held in Salluit and Kangiqsujuaq in September, 2012

In September, 2012, a member of the CRI management team met leaders of the villages and landholding corporations of Salluit and Kangiqsujuaq to present them with the revised port infrastructure project, and the stakeholder consultation report.

In Kangiqsujuaq, the CEO of the landholding corporation, Aloupa Kulula, had no specific comments. He found it interesting that the current design causes less impact than the design of 2007. He appreciated that the CRI had sent the consultation report to stakeholders. Mary Pilurtuut, Mayor of NV Kangiqsujuaq, was also met. The new port infrastructure concept and the consultation report were presented to her. She said she would forward the information to the municipal councilors.

A meeting that was scheduled with Charlie Alaku, President of the Landholding Corporation, did not take place. In Kangiqsujuaq, individual meetings were held on September 15 and 17, 2012 with two representatives of the landholding corporation and one representative of the municipal council. They did not make any specific comments after the presentation of the future port facilities. One of them said that he appreciated the fact that the concept seemed to have fewer impacts on Deception Bay than the 2007 proposal. They also appreciated receiving the consultation report. In general, these representatives appreciated being informed of the various project options, including those on the choices of the dredged sediment management site.

Meetings were held in Salluit on September 18, 2012 with two representatives of the landholding corporation and one representative of the municipal council. These representatives said they appreciated the new wharf concept and the fact that the footprint of permanent infrastructures in Deception Bay was reduced, compared to the old concept. They also appreciated the decision to reuse pieces of the current temporary wharf in the construction of the permanent wharf.

The six alternatives studied for the dredged sediment management site, and the preferred options were presented. The possibility that these materials could be transported to China was also discussed, an option they preferred to the others. In the following few weeks, they hoped to visit the sites studied to make an informed decision. This visit did not take place; the representatives decided it was not necessary. The members of the board of directors of the landholding corporation stated their opinions on the two options they preferred. They said the final choice was up to the CRI. The transmission of the consultation report was appreciated, since some people had noted that the public needed more information about the environmental process.

5. METHODOLOGY

This section describes the methods employed during various inventory campaigns conducted in the study zone. They focused especially on the physical and biological environments of Deception Bay. Other field inventories and campaigns made it possible to characterize certain components of the terrestrial environment, including special-status plant species, avian fauna and the archeological potential. In the case of components of the environment that were the subject of sector reports (archeology, hydrodynamics, underwater sound environment, avian fauna, flora and landscape), the methods employed are described in these reports.

Finally, the methodology used to assess the project's effects on the environment is presented at the beginning of Section 8.

5.1 Physical Environment

5.1.1 Review and Analysis of the Existing Information

To analyze the components of the physical environment, three main studies were consulted (Stantec, 2012; Stantec, 2011; Laboratoires d'Expertises de Québec Itée [LEQ], 2007). These expert studies were conducted within the context of geotechnical analyses for the drafting of design criteria for the future port infrastructures. The results of granulometric analyses coming from these studies, as well as the GENIVAR study (2012) were also considered. In addition, a study of the avalanche risk in the Deception Bay sector (NG1 and Sierra Neige, 2010), the numerous existing information in the sector report and in the ESIA (GENIVAR, 2007a and b), and several scientific publications were consulted. Finally, the surface deposits were mapped by aerial photography on a scale of 1:10,000.

5.1.2 Sedimentological and Oceanographic Survey Campaigns

Since the presence of the future port infrastructures may cause an alteration of the local currents and rebalancing in sedimentary transition, modelling of the flow was proposed by CRI to better describe the currents in Deception Bay.

This modelling also seeks to measure certain hydrodynamic parameters in order to meet two main objectives, namely:

1. attempt to predict the behaviour of the dispersion plumes created during dredging work that will be performed for deployment of the wharf;
2. evaluate the necessity of providing for maintenance dredging to maintain a sufficient water depth for ships.

To meet these objectives, a sedimentological and oceanographic survey campaign was conducted from July 30 to August 7, 2012 by GENIVAR. Thus, sediment core samples were taken and a description of the surface sediment of the seabed was produced. Water level measurements, bathymetric surveys, current measurements and physicochemical parameter readings were performed.

5.1.3 Core Sampling and Description of Sediments

The sampling campaign was conducted with a universal core head percussion corer. Two holes were bored at site Q1 (CO1 and CO2) and three holes at site Q2 (CO4, CO5 and CO6) (Map 5.1). The length of the core samples ranges from 20 cm to 110 cm. The analysis results are presented in Appendix 4.

The samples were transported to GENIVAR's Québec City warehouse and a visual characterization of the different sedimentary units was performed. Six subsamples were taken and sent to the Université Laval sedimentology and geomorphology laboratory for granulometric analyses. The subsamples submitted are:

- BD Q1_CO-1 0-10 cm;
- BD Q1_CO-2 5-15 cm;
- BD Q2_CO-5 10-25 cm;
- BD Q2_CO-6 0-28 cm;
- BD Q2_CO-6 28-34 cm;
- BD Q2_CO-6 34-45 cm.

A visual description of the seabed surface sediments was produced according to predefined records that account for the granulometric texture, compacity, wear and lithological nature of the sediments. The characterization was conducted at predefined stations of long transects in front of sites Q1 and Q2 (Map 5.1). The characterization was performed in two stages, first by direct observation of the seabed by the divers and then by the description of the first 15 centimetres of sediments collected with a grab at each station.

5.1.4 Water Level Measurements

The water levels were recorded at three locations in Deception Bay, for a period of more than 35 days with Solinst Levelogger Model 3001 sensors (LT F30/M10) (Map 5.2). This measuring campaign made it possible to correct the depths relative to the water levels recorded with the sensors and to express the bathymetric data relative to the Chart Datums.

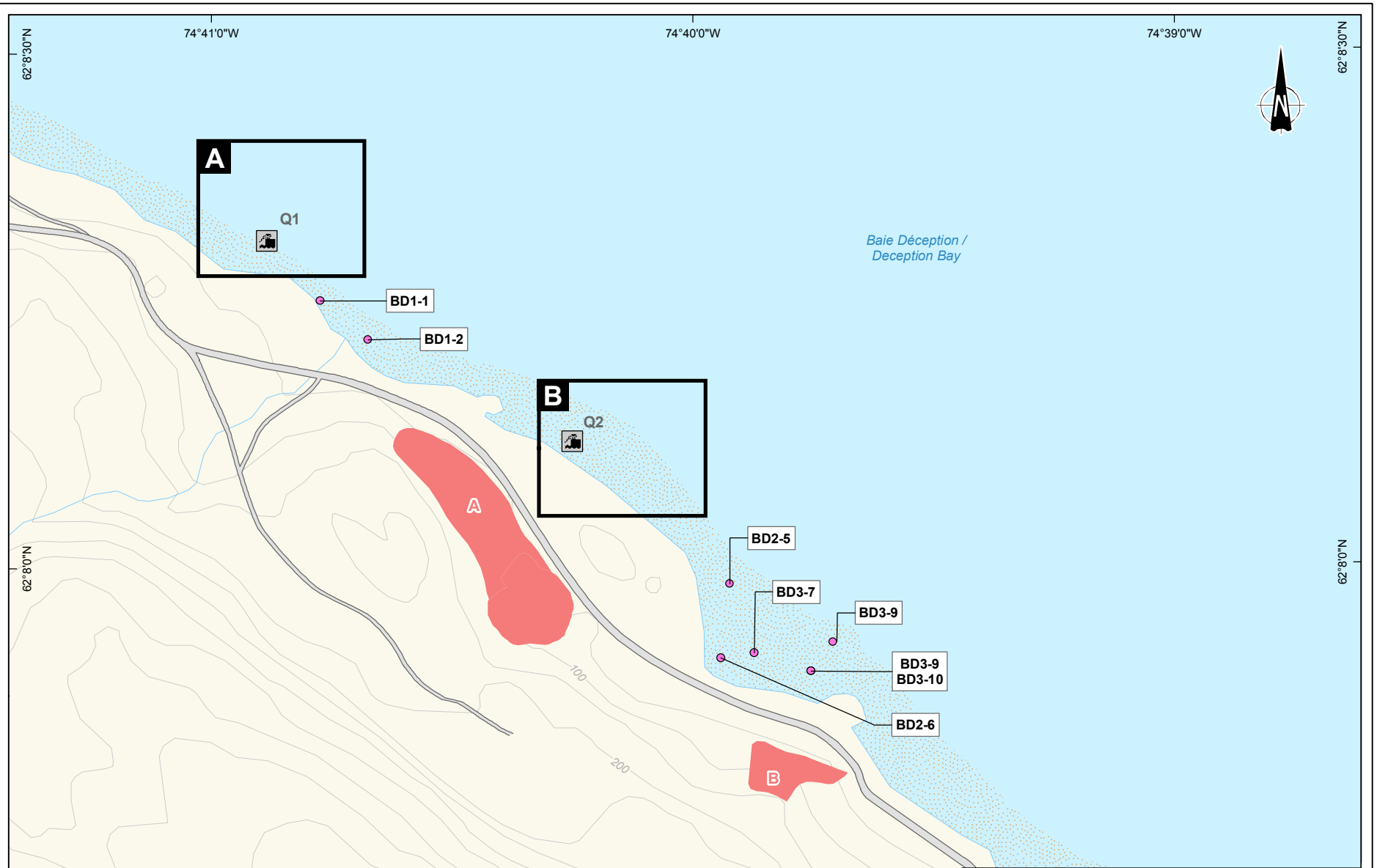
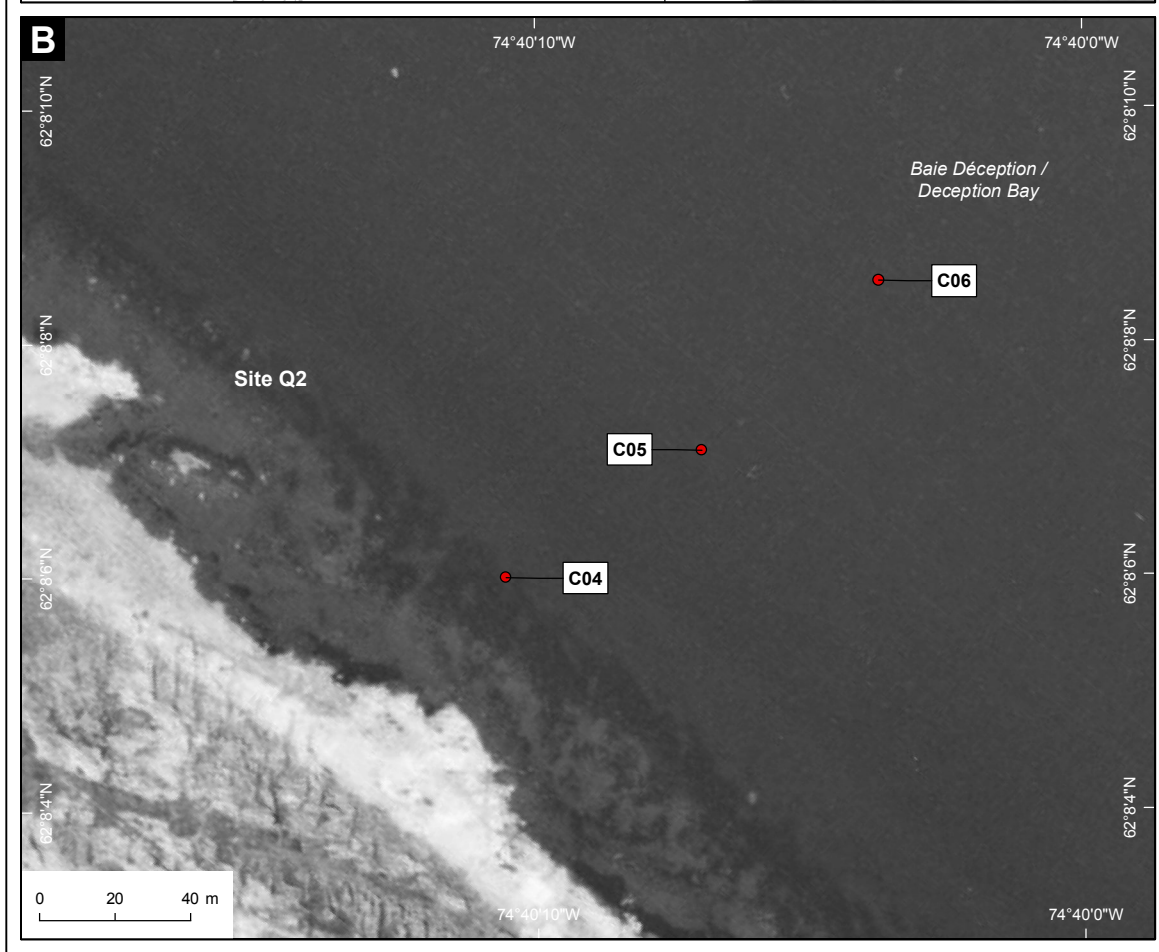
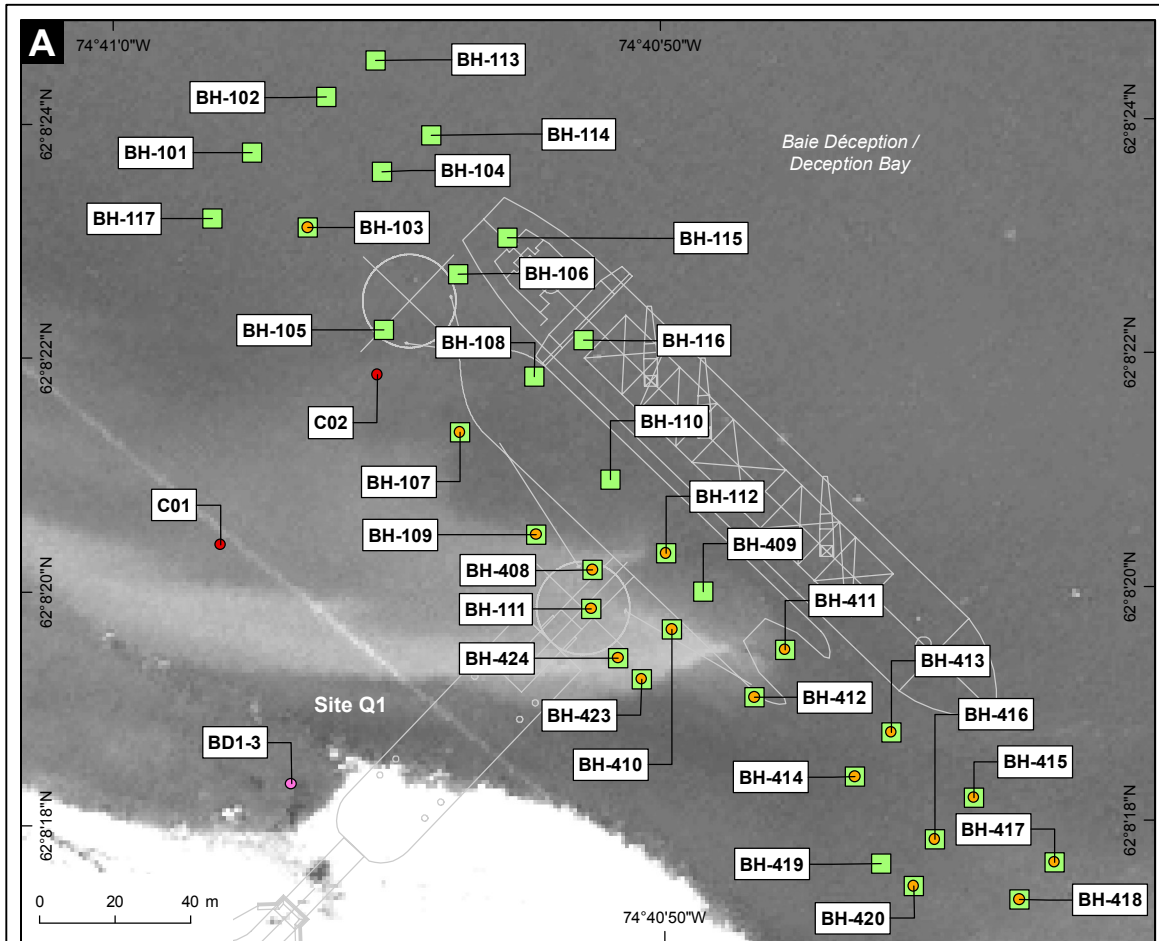

Échantillonnage / Sampling

- **BH-102** Analyse physico-chimique / Physicochemical analysis (Stantec, 2012)
- **BH-414** Analyse granulométrique / Granulometric analysis (Stantec, 2012)
- **C02** Analyse granulométrique / Granulometric analysis (GENIVAR, 2012)
- **BD1-2** Analyse granulométrique / Granulometric analysis (GENIVAR, 2007)

Composantes du projet / Project Components

- Infrastructures portuaires projetées (variantes) / Proposed wharf (variants)
- Site de dépôt des sédiments (variantes) / Sediment disposal site (variants)
- Zone d'étude / Study area

Infrastructures existantes / Existing Infrastructure

- Infrastructures portuaires / Wharf
- Route / Road

Projet Nunavik Nickel / Nunavik Nickel Project
 EIES pour l'aménagement d'infrastructures portuaires et la gestion des sédiments à la baie Déception / ESIA for the Deception Bay Wharf and Sediment Management

Carte 5.1 / Map 5.1

Localisation des stations d'échantillonnage de sédiment pour les analyses physico-chimiques et granulométriques / Sampling Stations Locations for Sediment Physicochemical and Granulometric Analysis

Projection : UTM, zone 18, NAD83
 Équidistance des courbes / Contour Interval : 50 pieds / feet

Source :
 Base : BNDT, 1 : 50 000, 1976 à 1995**, © Sa Majesté la Reine du Chef du Canada, reproduit avec la permission de RNCAN
 Inventaires et cartographie / Surveys and mapping : GENIVAR
 Fichier / File : 101_53046_EIES_BD_cs_1_sed_granulo_121120.mxd
Novembre / November 2012
 101-53046-02

5.1.5 Bathymetric Surveys

Bathymetric surveys were conducted from a zodiac boat opposite sites Q1 and Q2 and in front of Sensor No. 3 facing the CRI temporary camp (Map 5.2). These surveys were conducted with an ODOM, model HT 100 bathymetric echosounder, with a frequency of 200 kHz and a Z-axis precision of 0.1%. The DGPS (MobileMapper CX) linked to the echosounder offers an X-axis and Y-axis precision of less than 1.0 m.

For each water depth measurement, the time and the position were also recorded simultaneously via the use of HYPACK hydrographic survey software. The use of this data concomitantly with the water level data from Sensors No. 2 and No. 3 allowed adequate establishment of the depths relative to the Chart Datums.

5.1.6 Current Measurements, Waves and Flow

Several instruments (drifters, ADCP [Acoustic Doppler Current Profiler], turbidity sensor and CTD [conductivity, temperature, depth] sensor) were deployed to measure the currents, the waves and the physicochemical parameters of the water.

5.1.6.1 Drifters

The drifters are two metal plates laid out crosswise and attached to a float by a chain of a predetermined length, so that the device drifts freely with the currents. To characterize and visualize the flow of the surface currents, six drifters were placed at 1 m (n = 3) to 3 m (n = 3) below the surface of the water.

The drifters were launched several times during flood tide and ebb tide near sites Q1 and Q2, and in front of the CRI temporary camp (Map 5.2). For each drifter, position coordinates were taken regularly with a GPS (Garmin model ETREX). This positioning data made it possible to visualize the trajectories of the drifters and deepen the knowledge of the bay's surface currents.

5.1.6.2 ADCP

The speed and direction of the currents all along the water column were measured with a 300 kHz Workhorse Sentinel ADCP current profiler. This instrument, fastened to the boat and positioned by means of the DGPS, allowed measurements to be taken along transects. These transects are located at the entrance to Deception Bay (Transect 1) and near the future port facilities (Transect 2) (Map 5.2). The position of

these transects makes it possible to produce a general picture of the flow and exchanges of water between Deception Bay and Hudson Strait, and particularly to characterize the currents in front of sites Q1 and Q2. Several surveys were conducted along Transects 1 and 2. However, we should mention that the poor navigation conditions at the entrance to the bay limited the number of surveys of Transect 1.

5.1.7 Turbidity and CTD Sensors

The water quality profiles were produced with a YSI 600 OMS V2 turbidity sensor, used jointly with a Solinst model CTD (conductivity, temperature, depth) sensor. Vertical deployment of these sensors allows collection of several physicochemical measurements along the entire water column, i.e. temperature, conductivity, pressure and turbidity. The data collected allow production of turbidity, temperature and salinity profiles according to the depth. These profiles, considered in perspective with the tidal conditions at the time of the measurement, also allow interpretation of the source of water masses.

These sensors thus were deployed several times at the centre of Transects 1 and 2. Additional profiles were produced near the mouth of the Deception River and facing sites Q1 and Q2. When the sensors were lowered, measurements were taken every 2.5 m, down to the river bottom.

Finally, water samples integrated into the entire water column were taken at 25 stations to measure suspended particulate matter (SPM): 10 at site Q1, 10 at site Q2, two near the mouth of the Deception River and one in front of the CRI temporary camp. This data is intended to describe the natural variability of water quality and thereby assess the potential impacts of dredging operations during construction of the port infrastructures.

5.2 Biological Environment





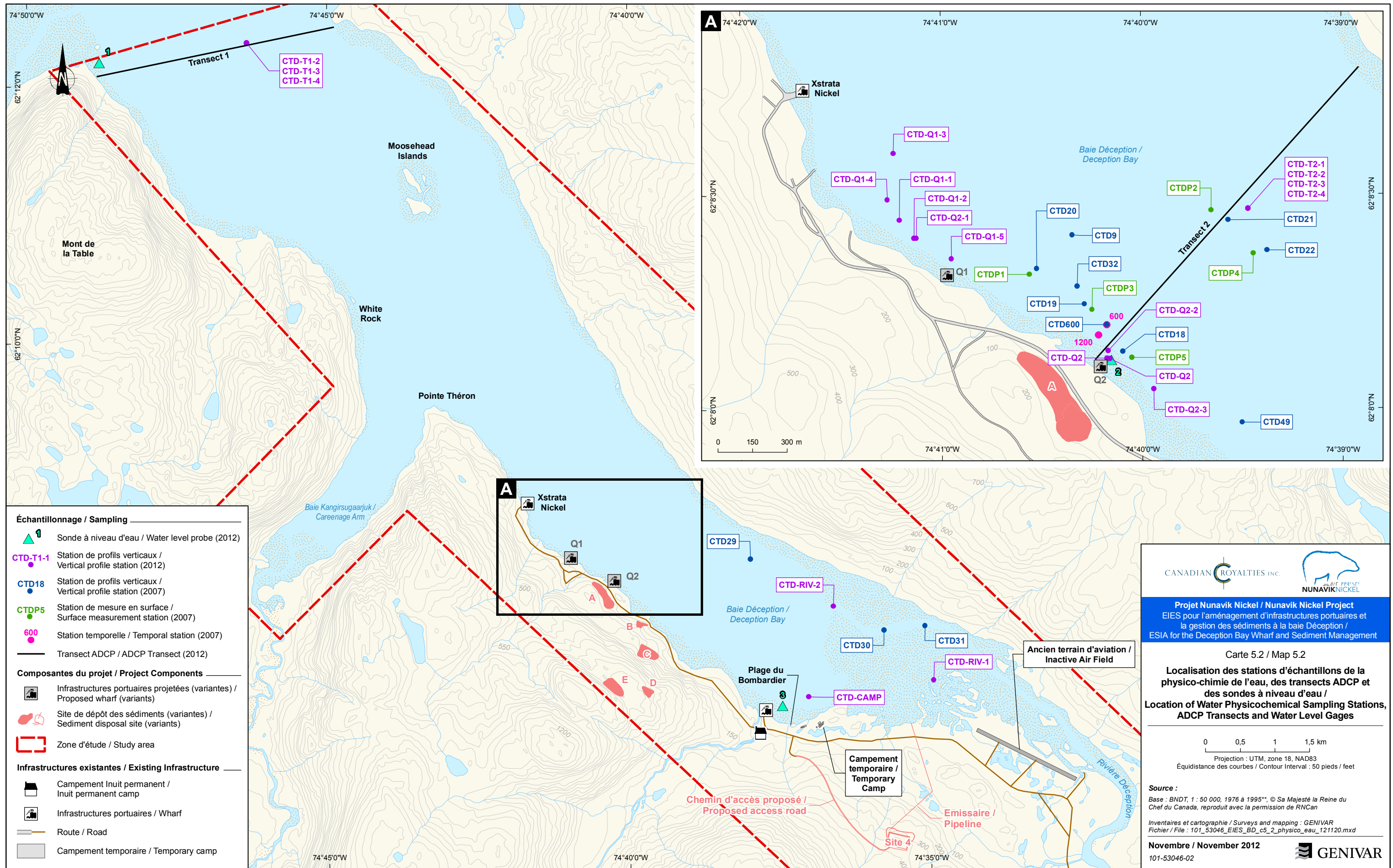

5.2.1 Marine Environment

5.2.1.1 Benthic Wildlife Inventory Protocols for 2007, 2008 and 2011



Within the context of studies of the marine environment conducted in Deception Bay, several inventories of benthic invertebrate communities were conducted.







Échantillonnage / Sampling

-  Sonde à niveau d'eau / Water level probe (2012)
-  CTD-T1-1 Station de profils verticaux / Vertical profile station (2012)
-  CTD18 Station de profils verticaux / Vertical profile station (2007)
-  CTD-P5 Station de mesure en surface / Surface measurement station (2007)
-  600 Station temporelle / Temporal station (2007)
-  ———— Transect ADCP / ADCP Transect (2012)

Composantes du projet / Project Components

-  Infrastructures portuaires projetées (variantes) / Proposed wharf (variants)
-  Site de dépôt des sédiments (variantes) / Sediment disposal site (variants)
-  [Red dashed line] Zone d'étude / Study area

Infrastructures existantes / Existing Infrastructure

-  Campement Inuit permanent / Inuit permanent camp
-  Infrastructures portuaires / Wharf
-  ———— Route / Road
-  Campement temporaire / Temporary camp



Projet Nunavik Nickel / Nunavik Nickel Project
 EIES pour l'aménagement d'infrastructures portuaires et la gestion des sédiments à la baie Déception / ESIA for the Deception Bay Wharf and Sediment Management

Carte 5.2 / Map 5.2
Localisation des stations d'échantillons de la physico-chimie de l'eau, des transects ADCP et des sondes à niveau d'eau / Location of Water Physicochemical Sampling Stations, ADCP Transects and Water Level Gages

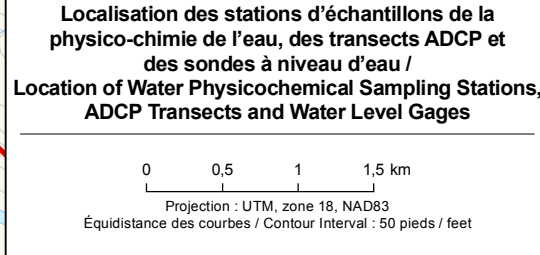

Source :
 Base : BNDT, 1 : 50 000, 1976 à 1995**. © Sa Majesté la Reine du Chef du Canada, reproduit avec la permission de RNCan
 Inventaires et cartographie / Surveys and mapping : GENIVAR
 Fichier / File : 101_53046_EIES_BD_c5_2_physico_eau_121120.mxd

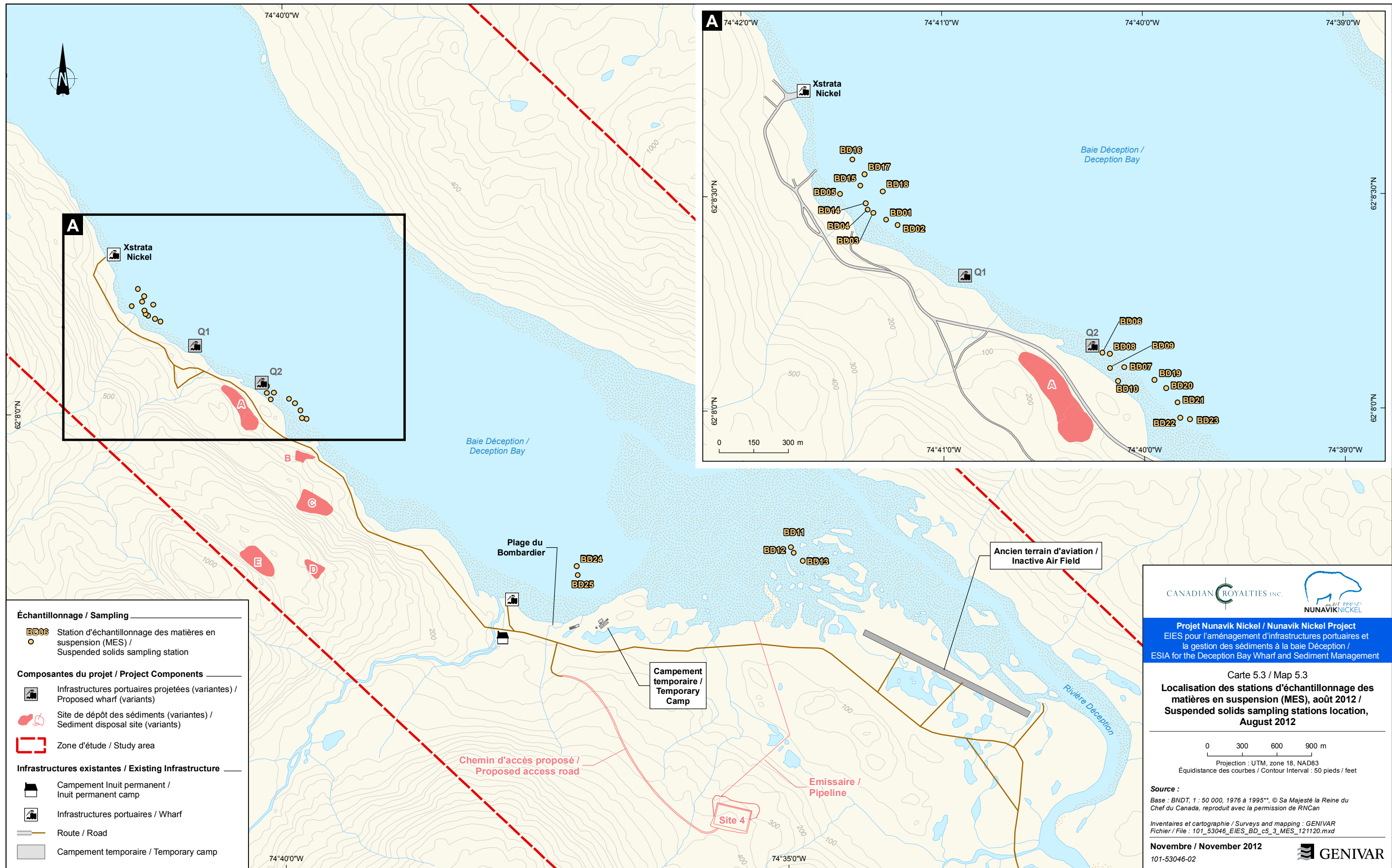

Échantillonnage / Sampling

BD08 Station d'échantillonnage des matières en suspension (MES) / Suspended solids sampling station

Composantes du projet / Project Components

Infrastructures portuaires projetées (variantes) / Proposed wharf (variants)

Site de dépôt des sédiments (variantes) / Sediment disposal site (variants)

Zone d'étude / Study area

Infrastructures existantes / Existing Infrastructure

Campement Inuit permanent / Inuit permanent camp

Infrastructures portuaires / Wharf

Route / Road

Campement temporaire / Temporary camp

CANADIAN ROYALTIES INC.

Projet Nunavik Nickel / Nunavik Nickel Project
 EIES pour l'aménagement d'infrastructures portuaires et la gestion des sédiments à la baie Déception /
 ESIA for the Deception Bay Wharf and Sediment Management

Carte 5.3 / Map 5.3
Localisation des stations d'échantillonnage des matières en suspension (MES), août 2012 /
Suspended solids sampling stations location, August 2012

0 300 600 900 m
 Projection : UTM, zone 18, NAD83
 Équidistance des courbes / Contour Interval : 50 pieds / feet

Source :
 Base : BNDT, 1 : 50 000, 1976 à 1995**, © Sa Majesté la Reine du Chef du Canada, reproduit avec la permission de RNCAN

Inventaires et cartographie / Surveys and mapping : GENIVAR
 Fichier / File : 101_53046_EIES_BD_c5_3_MES_121120.mxd

Novembre / November 2012

101-53046-02

In 2007, two distinct sampling methods were used to characterize the benthic diversity of sites Q1 and Q2. In July, video transects were conducted at site Q1. In a complementary operation, Ponar grabs (covering an area of 0.023 m²) were deployed at seven stations distributed in this same sector. All this data made it possible to identify the benthic macrofauna found on the sediments (epibenthos), and in the sediments (endofauna) of the study zone. The Blue Mussel population present near sites Q1 and Q2 was also analyzed.

Aquatic grass beds were inventoried between February and March 2008. Holes were bored in the ice with an auger to lower an underwater camera and take videos. The stations were distributed along isobaths of 2, 5, 12 and 20 m, determined from the marine charts of the Canadian Hydrographic Service (CHS). A complementary study was deposited in April 2008 (GENIVAR, 2008) to document these seagrass beds in the site Q3 sector.

In 2011, the inventory was only conducted visually. From October 6 to 11, 2011, an underwater diving team proceeded with an inventory of marine fauna and flora at Q1 and Q2. Fifteen underwater videos were taken throughout the two sites.

5.2.1.2 2012 Field Campaign – Benthic Fauna and Aquatic Grass Beds

The August 2012 field campaign had the objective of collecting data to answer the questions raised after the 2011 ESIA was deposited. Most of these questions concerned the lack of quantitative faunal information (density and diversity). In the present case, given that the sea immersion option was abandoned, the benthic fauna was characterized only at sites Q1 and Q2.

The field campaign was conducted on August 23 and 31 and divided into two distinct parts. In the first stage, eight video transects, four for each of the two sites, were conducted by underwater divers (Map 6.4). At each transect, a 30 cm x 30 cm quadrat was deposited six times. A distance of about 15 m separated the quadrats from each other. Transects 1 to 4 were characterized at site Q1 and Transects 5 to 8 at site Q2 (Map 6.4).

A stop motion video was taken for all quadrats. The divers thus were able to inventory the epibenthic fauna and the aquatic grass beds. The percentage coverage for each species composing the aquatic grass beds was noted.

Once the analysis of the benthic fauna and flora was completed, a 2.4 L Ponar grab covering an area of 0.023 m² was deployed to collect a sample of the endobenthic fauna. The type of sediment present sometimes made grab sampling difficult. In the

24 attempts, eight refusals were encountered. A field technician immediately proceeded to sift the samples with a 0.5 mm mesh sieve. Stored in a formaldehyde solution buffered with seawater, the 16 samples then were sent to the benthic ecology laboratory of the Institut des Sciences de la mer de Rimouski (ISMER) to identify the collected organisms and estimate their density. The identification was performed with the greatest possible taxonomic precision.

Data Entry and Analysis

At the end of each work day, the divers entered the results regarding the grass beds and the epibenthic fauna directly in a database. Once validated, this database allowed production of Table 6.19 (subparagraph 6.2.1.2), which presents the grass bed coverage percentages.

A similar method was performed for the epibenthic fauna. The divers thus entered the data as they observed it in order to produce Table 6.20 (subparagraph 6.2.1.2). Note that only occurrence data (presence or absence) is presented for this section.

Concerning the endobenthic fauna, the ISMER laboratory was able to supply a database indicating all the species found and their respective densities. This data was converted into number of individuals /m² (Table 6.21; subparagraph 6.2.1.2). Diversity indices then were calculated on this database, via use of PRIMER 5 statistical software (Primer-e-Ltd).

5.2.2 Terrestrial Environment

5.2.2.1 Special-Status Plant Species

The plant inventories were conducted from July 20 to 25 and concerned site Q1, site Q2 and the terrestrial deposit sites 4 (including the route of the access road and of the drainage water outfall) and B (Map 1, Appendix 13), as well as Bombardier Beach from the existing camp site to the abandoned landing strip.

All the sites listed above were inventoried, but the inventory effort mainly focused on site 4, the route of the access road and the route of the outfall. A total of 95 habitats distributed over 80 sites were inventoried. The main vegetation types were also characterized by 28 vegetation surveys.

5.3 Human Environment

The data and information that served to describe the human environment was mainly taken from the ESIA and the sector reports produced in 2007 for the NNiP (GENIVAR, 2007a and 2007b). An update was produced, particularly based on the 2011 Census data. In fall 2012, a failed attempt was made to update the data (by guided interviews) of the harvesting of Deception Bay resources by the Inuit of Salluit.

6. DESCRIPTION OF THE ENVIRONMENT

6.1 Physical Environment

6.1.1 Geology

Regional Geological Framework

The Deception Bay region overlaps two geological provinces: Hearne and Superior (Figure 6.1). Hearne Province is a craton² dating from the Archaean Eon (> 2.6 billion years [Ga]), which collided with Superior Province. This event is called the Trans-Hudson orogen and occurred about 1.6 Ga, at the end of the Paleoproterozoic Era (Landry and Mercier, 1992; Mouksil, 1996). Many overlap faults are thus present throughout the study region (Figure 6.2).

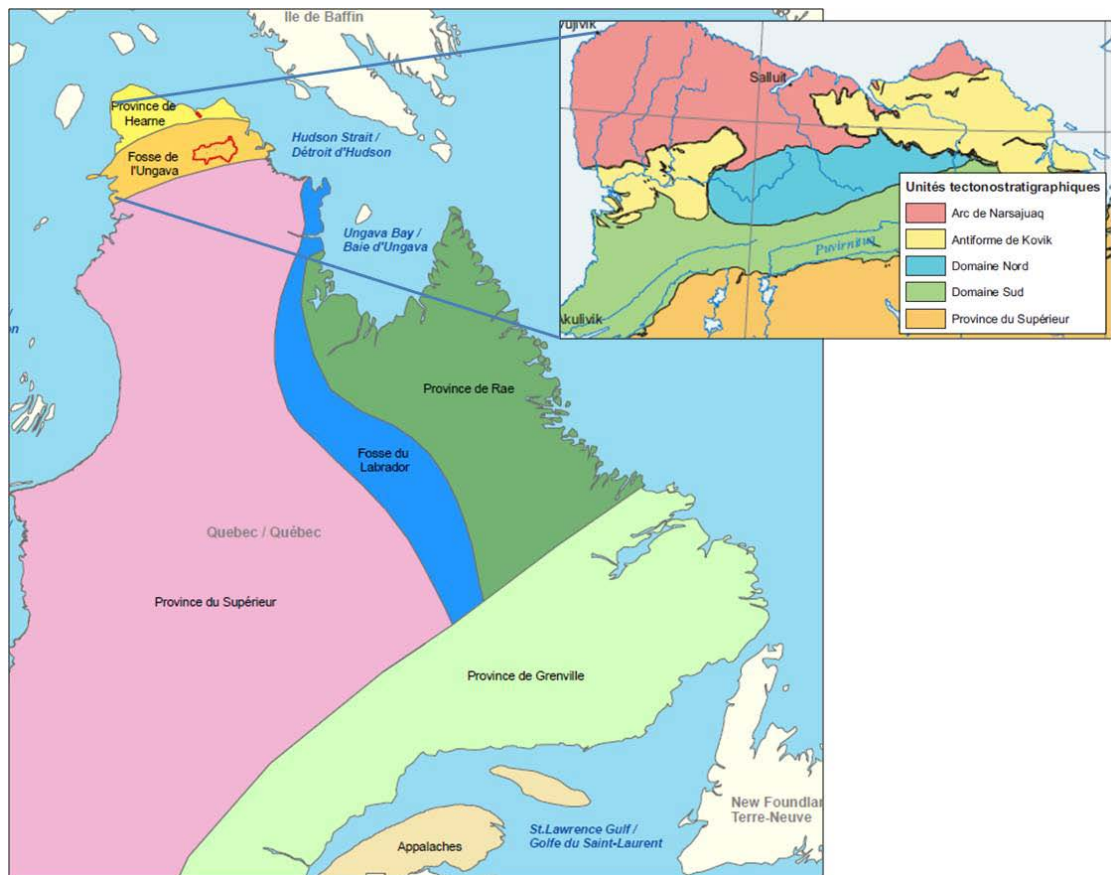

Figure 6.1 Geological provinces of Québec and tectonostratigraphic units (modified from GENIVAR, 2007 and Mouksil, 1996).

² Ancient continental block

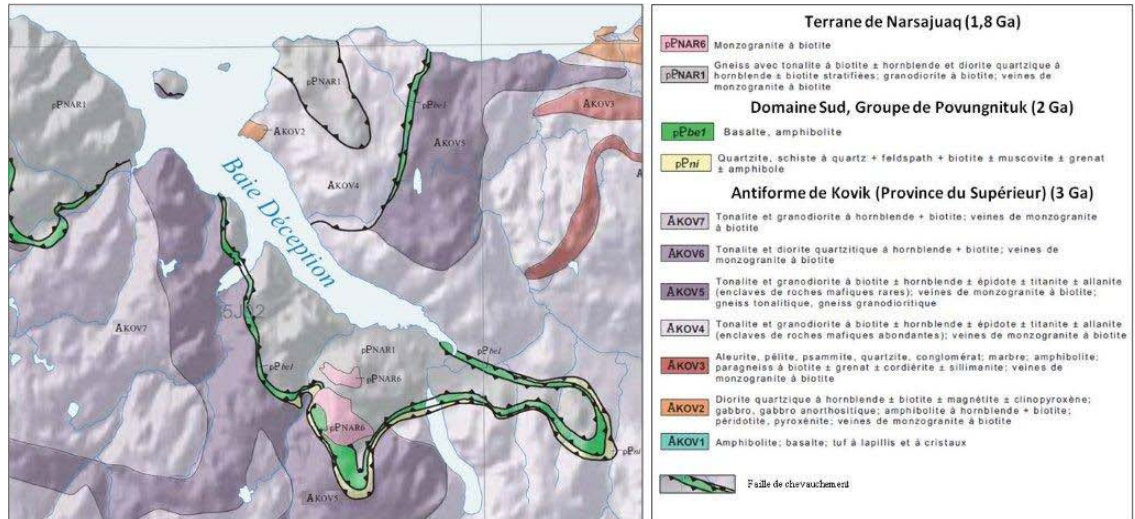

Figure 6.2 Lithology of the study site (modified from Lamothe, 2007).

The region thus is divided into four main tectonostratigraphic units (Figure 6.1), namely, from south to north:

1. autochthonous (preexisting) bedrock of Superior Province, mainly composed of igneous rocks;
2. klippe forming the allochthonous lands of the Ungava Trough, i.e. the South and North Domains, mainly composed of sedimentary and volcanic rocks. The nickel and copper deposits are found in these units;
3. the Kovic Antiform of the parautochthonous domain of Superior Province, meaning that the rocks of this zone were deformed but not displaced (overthrust) during the collision with Hearne Province;
4. the Narsajuaq Arc (or Terrane), composed of the bedrock of Hearne Province.

Directly around Deception Bay, the overlap faults delimit the units of the Kovik Antiform to the south from the units belonging to the Narsajuaq Terrane farther north (Figure 6.2). The rocks found in the study zone belong to the Narsajuaq Terrane and are composed of metamorphic rocks, mainly gneiss and diorite, granodiorite and monzogranite intrusions (Figure 6.2).

Seismicity

The Deception Bay sector is located in a seismic zone 3, i.e. a zone where seismicity is of medium intensity. The peak ground acceleration (PGA), estimated for solid ground and for the rock, is presented in Table 6.1. PGA is a value expressed as a fraction of gravity (g) for foundation design (GENIVAR, 2007).

Table 6.1 Design criteria chosen for infrastructure earthquake resistance

Recurrence (years)	Annual probability	50-year probability	PGA (solid ground) (g)	PGA (rock) (g)
100	0.01	0.40	0.022	0.16
475	0.0021	0.10	0.066	0.048
1,000	0.001	0.05	0.104	0.075
2.475	0.0004	0.02	0.167	0.120

6.1.2 Geomorphology

6.1.2.1 Relief and Bathymetry

Deception Bay is located in the James physiographic region in the vast natural region of the Ungava Plateau. This region's coastline is dominated by the presence of imposing fjords³. Deception Bay is one of these deep valleys, 20 km long and opening into Hudson Strait (Map 6.1). The width of the bay varies, upstream to downstream, from 2 km to over 10 km. The bay is bounded by small rounded rocky hills peaking at 580 m of altitude. The slopes of these hills plunge almost directly into the bay, leaving little room for development of the shoreline, which generally is between 50 and 100 m wide. The bathymetric curves show that a steep talus slope surrounds Deception Bay. Finally, two major basins more than 80 m deep are separated by a sill less than 40 m deep (Map 6.1). These relief features are typical of the overdeepening of the valley's bedrock by glacial flow.

Directly in the study zone, the hills reach about 400 m (1,300') of altitude (Map 6.1). The sector's valleys are shallowly incised and have a relatively gentle slope. Completely upstream from the bay is the delta plain of the Deception River. In the port infrastructure implementation zone, the shoreline is hemmed in between two relatively steep hills. The valley between the two hills opens very close to site Q1 and upland disposal site A. Finally, the slope between the shore and the road varies between 1:4 and 1:6.5 (GENIVAR, 2007a).

The bathymetry in front of site Q1 shows a steep talus slope (1:10) to a depth of 30 m (Map 6.1). Beyond this isobath, the slope becomes gentler. The talus seems to be incised by channels that could potentially convey sediments by gravity to the deep basins. Finally, the bathymetry in front of site Q1 shows the forms of the submarine slide that occurred in the summer of 2011 during the wharf construction work.

³ Deep U-shaped valleys, overdeepened by the passage of glaciers, their bottom filled with thick layers of glaciomarine deposits.

6.1.2.2 Stratigraphic Context and Surface Deposits

The current rocky terrain of Deception Bay (both in the emerged and submerged environment) is mainly due to erosion of the bedrock over several glacial cycles. The loose deposits covering this rocky terrain are mainly the result of the last retreat of the Laurentide Ice Sheet and the invasion of the postglacial Irberville Sea. These latest phases of geological history left a relatively simple sequence of loose deposits. The sedimentary units identified by the core hole drilling campaigns conducted in front of sites Q1 and Q2 (Golder, 2007; Stantec, 2011; 2012) reflect these different phases.

Table 6.2 Typical sedimentary sequence of the Deception Bay region.

Unit No.	Sedimentary sequence
4	Delta and shoreline deposits
3	Distal glaciomarine deposits
2	Proximal glaciomarine deposits
1	Glacial deposits

It should be noted that the processes that put in place the different sedimentary units identified in the core holes are regional in scope. The spatial range of these units is thus just as regional as the processes that led to their sedimentation. This is why all these units outcrop on the surface at clearly defined altitudes, as shown by the mapping of the surface deposits (Map 6.2).

Glacial Deposits

The oldest unit is till, a deposit left directly by the glaciers. This is a mixture of heterometric sediments that often includes boulders of metric size.

Although till was not identified formally as a unit by Stantec (2011 and 2012) (Appendices 3 and 4), this unit nonetheless seems to appear at the base of certain core holes by the greater presence of boulders resting directly on the bedrock. Nonetheless, it is very likely that the latest glacial flows at the bottom of the fjord eroded the till layer.

In the study zone, the mapping of the surface deposits shows that till covers the tops and slopes of the hills (Map 6.2). The till layer is discontinuous, often allowing the rocky surface to appear. The places where the till is more than 1 m thick are more localized, and thin till is more frequently observed, even boulder fields resting directly on the rocky surface.

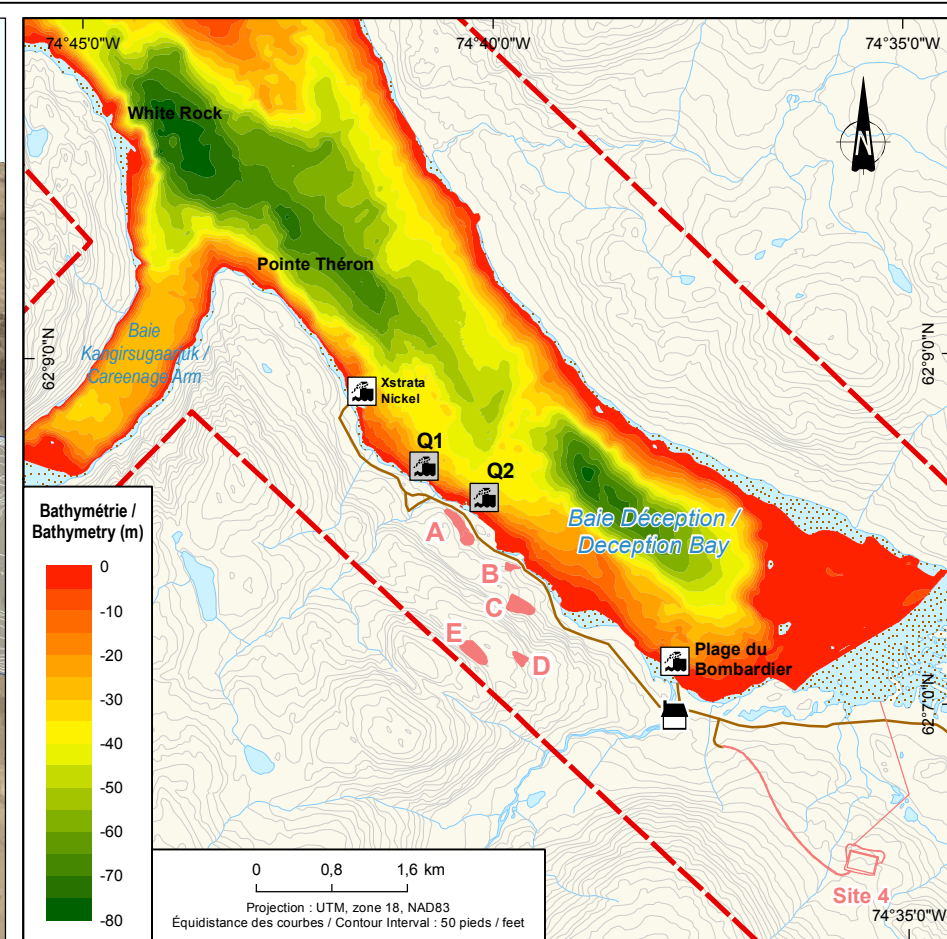
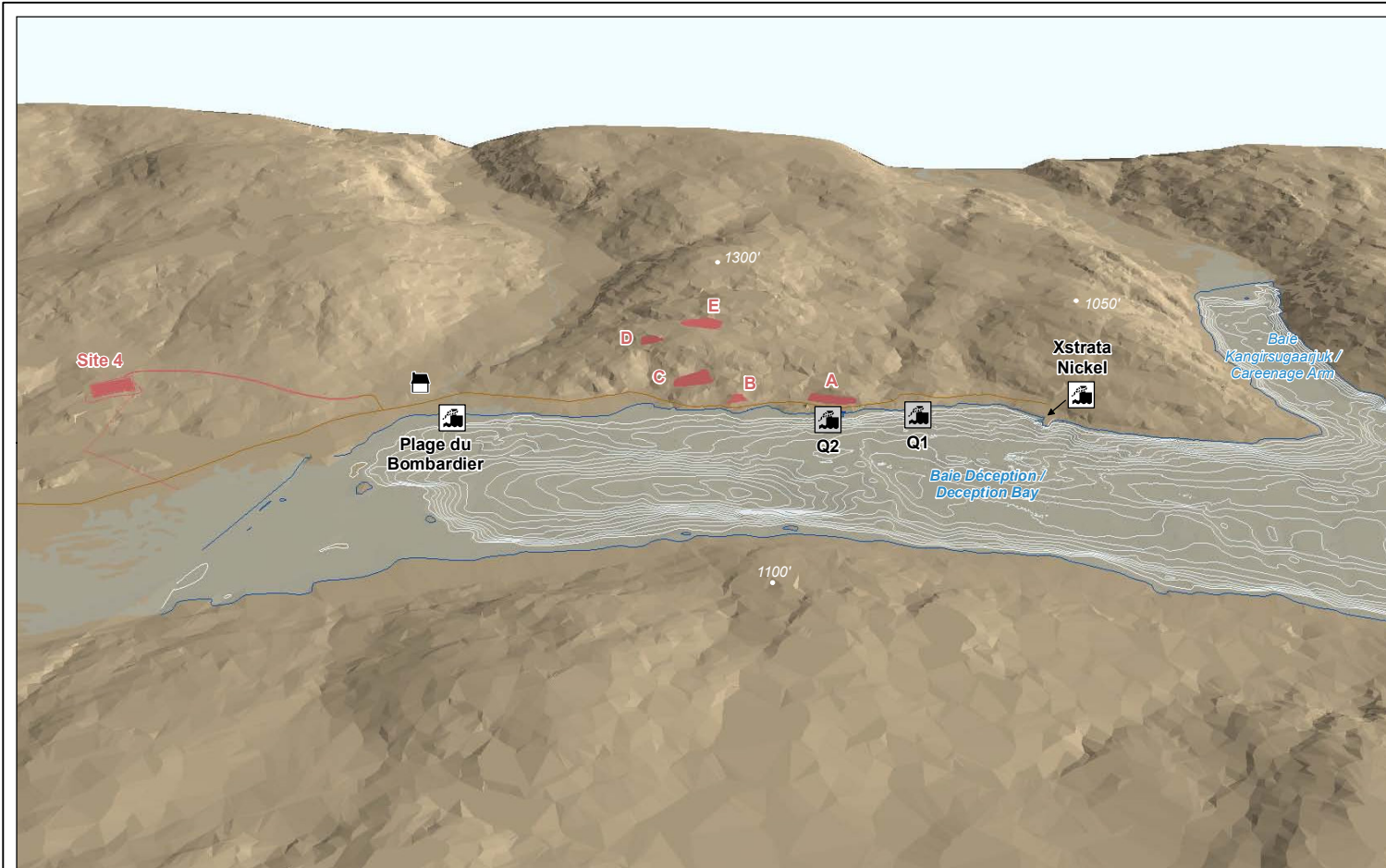

CANADIAN ROYALTIES INC. NUNAVIK NICKEL

Projet Nunavik Nickel / Nunavik Nickel Project
 EIES pour l'aménagement d'infrastructures portuaires et la gestion des sédiments à la baie Déception /
 ESIA for the Deception Bay Wharf and Sediment Management

Carte 6.1 / Map 6.1
**Relief et bathymétrie /
 Relief and Bathymetry**

Source :
 Base : BNDT, 1 : 50 000, 1976 à 1995** © Sa Majesté la Reine du
 Chef du Canada, reproduit avec la permission de RNCAN
 Inventaires et cartographie / Surveys and mapping : GENIVAR
 Fichier / File : 101_53046_EIES_BD_c6_1_relief_121120.mxd

Novembre / November 2012
 101-53046-02

GENIVAR

Composantes du projet / Project Components

- Infrastructures portuaires projetées (variantes) /
Proposed wharf (variants)
- Site de dépôt des sédiments (variantes) /
Sediment disposal site (variants)
- Zone d'étude / Study area

Infrastructures existantes / Existing Infrastructure

- Campement Inuit permanent / Inuit permanent camp
- Infrastructures portuaires / Wharf
- Route / Road

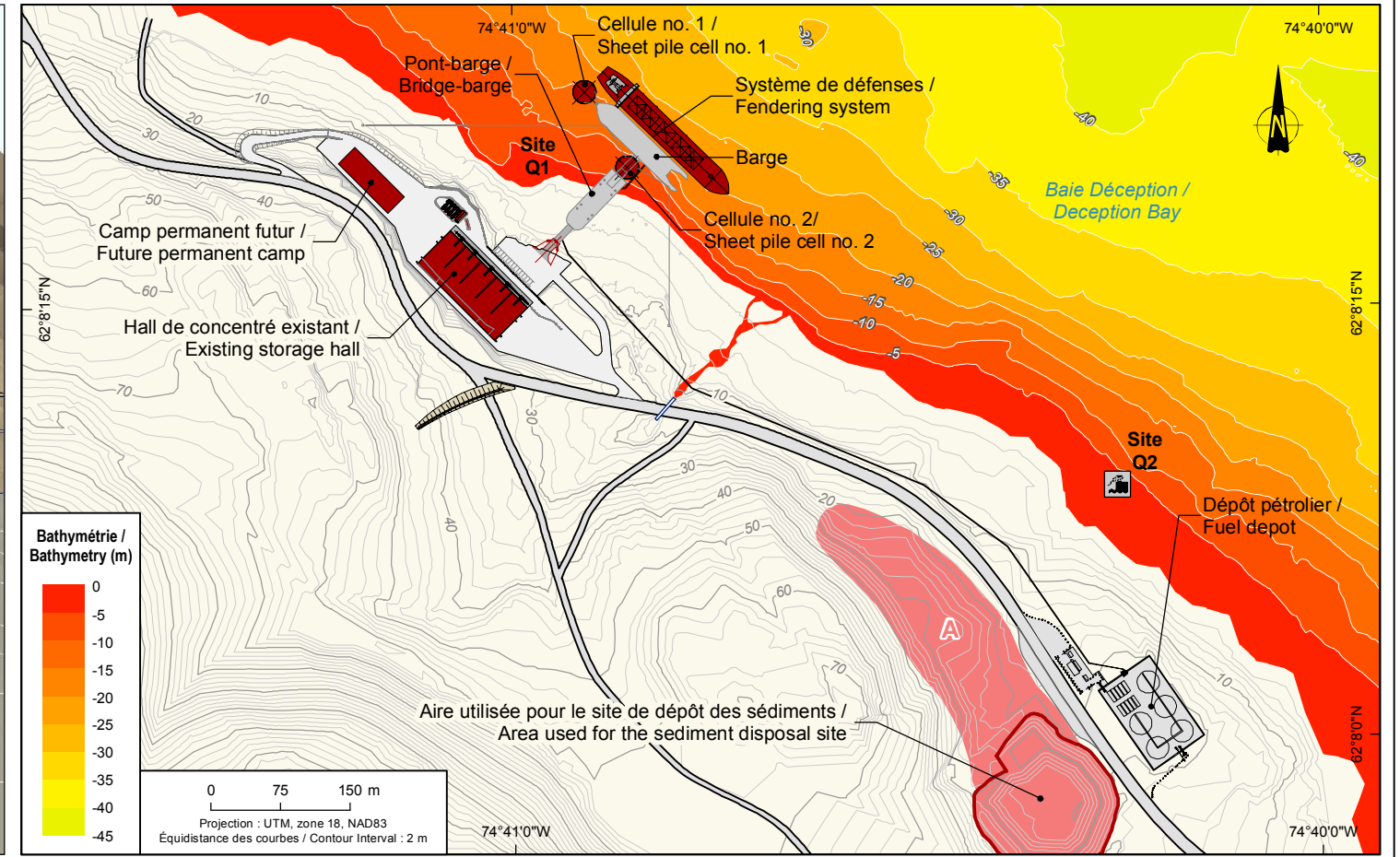
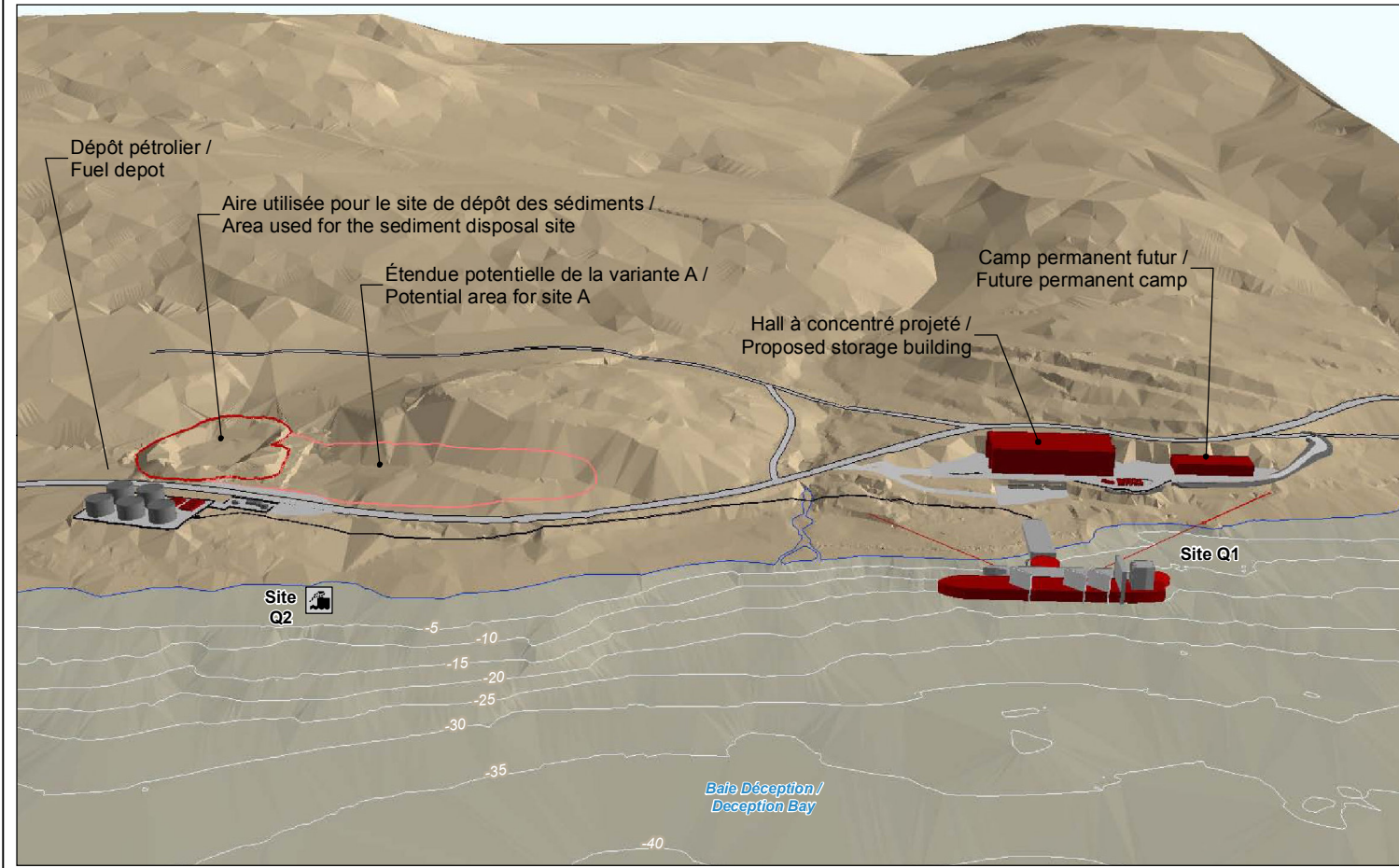

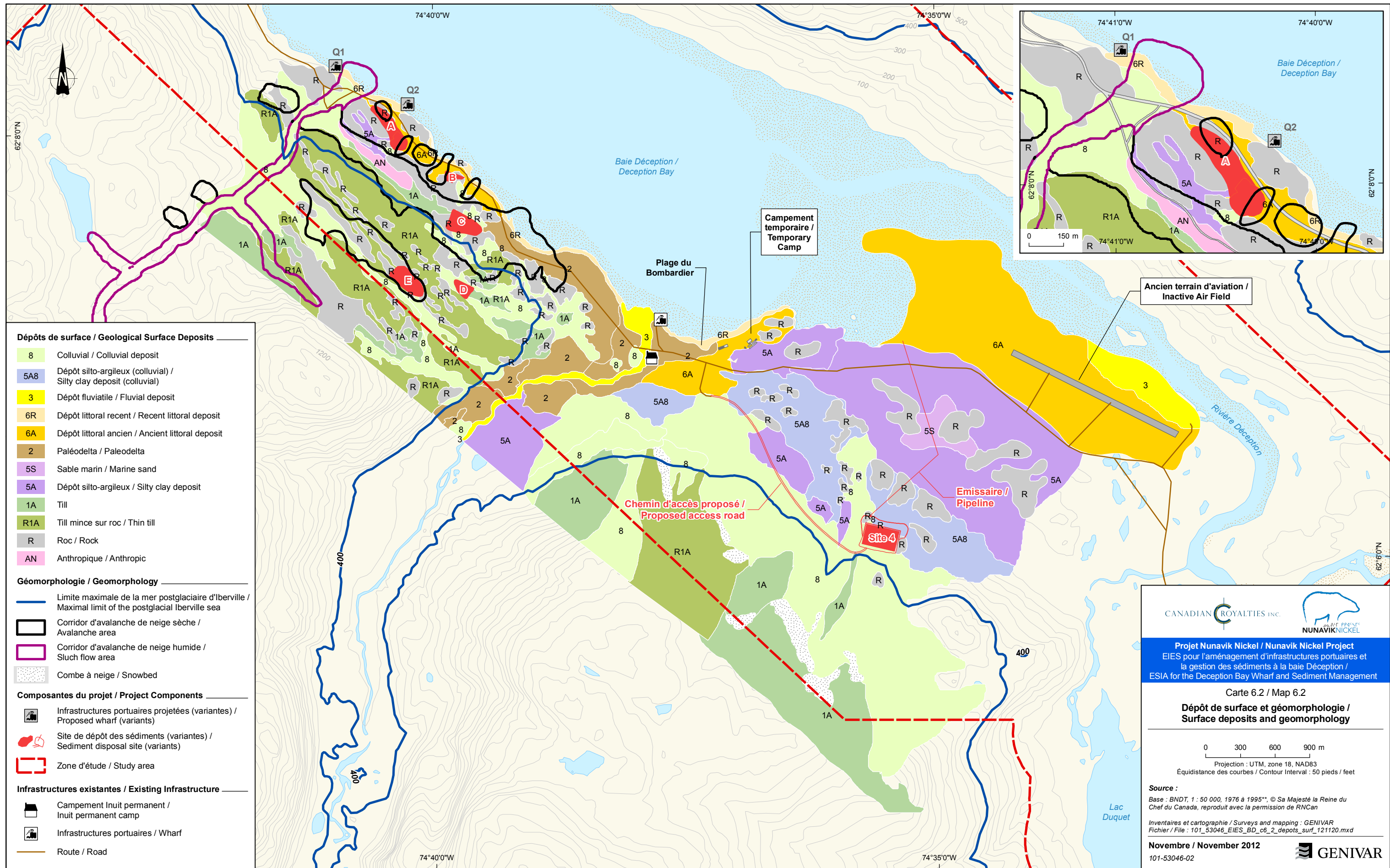

Dépôts de surface / Geological Surface Deposits

8	Colluvial / Colluvial deposit
5A8	Dépôt silto-argileux (colluvial) / Silty clay deposit (colluvial)
3	Dépôt fluvial / Fluvial deposit
6R	Dépôt littoral récent / Recent littoral deposit
6A	Dépôt littoral ancien / Ancient littoral deposit
2	Paléodelta / Paleodelta
5S	Sable marin / Marine sand
5A	Dépôt silto-argileux / Silty clay deposit
1A	Till
R1A	Till mince sur roc / Thin till
R	Roc / Rock
AN	Anthropique / Anthropogenic

Géomorphologie / Geomorphology

(Blue line)	Limite maximale de la mer postglacière d'Iberville / Maximal limit of the postglacial Iberville sea
(Black outline)	Corridor d'avalanche de neige sèche / Avalanche area
(Pink outline)	Corridor d'avalanche de neige humide / Sluch flow area
(Dotted pattern)	Combe à neige / Snowbed

Composantes du projet / Project Components

(Icon)	Infrastructures portuaires projetées (variantes) / Proposed wharf (variants)
(Icon)	Site de dépôt des sédiments (variantes) / Sediment disposal site (variants)
(Red dashed box)	Zone d'étude / Study area

Infrastructures existantes / Existing Infrastructure

(Icon)	Campement Inuit permanent / Inuit permanent camp
(Icon)	Infrastructures portuaires / Wharf
(Line)	Route / Road

CANADIAN ROYALTIES INC.

Projet Nunavik Nickel / Nunavik Nickel Project
 EIES pour l'aménagement d'infrastructures portuaires et la gestion des sédiments à la baie Déception /
 ESIA for the Deception Bay Wharf and Sediment Management

Carte 6.2 / Map 6.2

**Dépôt de surface et géomorphologie /
 Surface deposits and geomorphology**

0 300 600 900 m
 Projection : UTM, zone 18, NAD83
 Équidistance des courbes / Contour Interval : 50 pieds / feet

Source :
 Base : BNDT, 1 : 50 000, 1976 à 1995**, © Sa Majesté la Reine du
 Chef du Canada, reproduit avec la permission de RNCAN

Inventaires et cartographie / Surveys and mapping : GENIVAR
 Fichier / File : 101_53046_EIES_BD_c6_2_depots_surf_121120.mxd

Novembre / November 2012
 101-53046-02

Proximal Glaciomarine Deposits

The core holes indicate a unit composed of silty sand with a proportion of 15 % to 20 % gravel and boulders, resting discordantly on bedrock. The thickness of this unit ranges from 0.6 to 14 m (Stantec, 2011; 2012). This unit was sedimented at the very beginning of the marine invasion of the Iberville Sea, when the front of the ice sheet was located near Deception Bay, a little farther south of the study zone. This type of deposit does not outcrop on the surface of the study site.

Distal Glaciomarine Deposits

Distal glaciomarine deposits were sedimented from the time the level of the postglacial Iberville Sea reached its maximum altitude, i.e. 123 m relative to the current mean level, and thus less than 8,900 years BP⁴ (Gray *et al.*, 1993) (Map 6.2). These clayey silt deposits were sedimented in calm deep water. The core hole results also indicate that the thickness of this unit may reach 20 m (Stantec, 2012). According to the visual characterizations and the geotechnical tests conducted, these clays have a very soft consistency and no bearing capacity (Golder, 2007; Stantec, 2011; 2012).

The glaciomarine clay unit generally outcrops on the surface of the seabed. The divers' visual description, the description of the sediment core samples and the granulometric results show that the clay layer largely outcrops at sites Q1 and Q2 (Appendix 4). On the terrestrial portion of the study zone, the glaciomarine clay appears completely east of the study zone in the Deception River Valley (Map 6.2).

Delta and Shoreline Deposits

The delta deposits are the deposits abandoned by the watercourses when they flow into the sea. They are mainly composed of sand and gravel. However, boulders of metric size may also be found there. These deposits are identified in the river valley of Bombardier Beach (Map 6.2). This delta, sedimented when the sea level was higher than at present, extends northwest of the Deception Bay shoreline (Map 6.2). It is divided by many terraces formed by downcutting of the river when the sea level fell. The presence of these terraces allows us to affirm that these deposits may be over twelve metres thick and cover the glaciomarine clay deposit units.

⁴ BP = *Before Present*

All along the shoreline, both in its emerged and submerged portions (-4 m deep), the glaciomarine clays are sometimes covered by a deposit unit composed of silt or sandy silt up to an average of 2 m thick, but up to 6 m in a few rare places (Stantec, 2011; 2012). This unit is also observed in the sediment core samples collected in front of sites Q1 and Q2 (Appendix 4). These deposits are associated with sedimentation in a shallow marine environment, i.e. when the Iberville Sea retreated gradually from the land, in response to glacio-isostatic uplift.

The surface of this unit and the delta deposits of the Bombardier Beach River and especially those of the Deception River, were disturbed by the shoreline processes associated with the various sea levels. These former shoreline deposits are therefore elevated relative to the current sea level (Map 6.2).

Colluvial Deposits

All the surface deposits presented above have been subjected to different erosion agents since their placement. There are many of these colluvial deposits on the study site, mainly located on the hillsides or the talus slopes of the terraces (Map 6.2). They result from periglacial processes or mass movements resulting from the presence of mollisol. The processes that put the colluvial deposits in place are explained further in the next sections.

6.1.2.3 Dynamic Terrestrial Geomorphology

The presence of numerous colluvial deposits is evidence of the dynamics of the active processes in the study zone. The phenomena that could disturb the deposits are periglacial processes, hydrological processes and slope processes.

Permafrost

Deception Bay is in the continuous permafrost zone, meaning that the soil is frozen for a period of at least two consecutive years. The mean soil temperature remains lower than -5°C (Smith *et al.*, 2004) and the ground is frozen to a depth of about 500 m (Daigneault, 1997; Smith *et al.*, 2004). The surface layer that thaws during the summer is called the “active layer” or mollisol. The thickness of the mollisol depends on the nature of the loose deposit. For example, according to Allard *et al.* (2004), the mollisol at Salluit reaches a thickness of 1.3 m in till, 2 to 3 m in fluvio-glacial deposits and 0.6 to 1.1 m in clay. The soil drainage capacity is limited to this layer. In bedrock, the mollisol reaches a depth of 2.2 m (Lévesque *et al.*, 1990). The forms associated with the periglacial phenomena in the region are boulder fields, ice lenses, frost cracks, sorted soils, ostioles and polygonal soils, as well as solifluction lobes (Gray and Seppälä, 1991). These forms are too small to be mapped.

Hydrography and Hydrology

The rivers flowing directly into Deception Bay and located in the study zone are the Bombardier Beach River (Rivière de la Plage du Bombardier), a small torrent flowing in the Xstrata mine port infrastructure sector, a torrent flowing in the valley overlooking site Q1, and the Deception River. The biggest of these is the Deception River, which drains a watershed of 4,020 km² (Appendix 5).

This river is subject to a regime typical of northern environments. The presence of permafrost and the sporadic and discontinuous presence of shrubby and arborescent vegetation favour surface water runoff instead of infiltration, thus causing accentuated flood peaks that dry up very quickly in the absence of rain (GENIVAR, 2007a). The annual streamflow regime is subject to the following conditions:

- a very severe winter low-water period with streamflows of practically zero;
- gradual melting of the snow cover between the beginning of June and the end of July;
- a very severe summer low-water period occurring in August.

In view of the very non-hilly terrain, the increase in streamflows translates more into widening of the flow section than a rising water level, which limits its sediment transport capacity. According to the streamflow characterization of the Deception River (Appendix 5), its annual mean streamflow would be 144 m³/s, while its 2, 10 and 50-year flood recurrence is 246, 302 and 354 m³/s respectively. Its annual low-water periods are especially severe, with a 2 and 10-year recurrence (value for seven consecutive days) of 1.3 and 0.7 m³/s respectively.

Hydrogeology

The interstitial water present in the rock fissures and in the surface deposits is frozen all year round, except during the seasonal thaw period, for a mollisol thickness limited to the first two metres. The thawed groundwater flows according to the paths of greatest permeability, especially in the sand and gravel interbeds and through boulders, in the interstices, regardless of whether they are filled with sand and gravel. Permafrost limits the percolation of water in the soil (RÉSÉ Nord, 2005), which favours surface drainage in the spring and early summer, and a lateral flow in the mollisol in midsummer and late summer (GENIVAR, 2007a).

Groundwater inflow mainly occurs during snowmelt and summer rainfall. At other times, the groundwater is frozen and immobile. The water inflow is conditioned by the nature of the soil. With rising spring temperatures, the snow cover becomes very permeable (minimal water retention) and much less resistant to heat transfer. The melt water percolates into the soil, and two situations then can be observed. When the snow cover rests on low permeability soil, an ice lens is formed at the base of the snow cover, which prevents direct percolation into the soil and favours interstitial lateral flow in the snow cover. This flow, which can be very rapid, given the high porosity of the mature snow cover, normally is towards watercourses and lakes. However in unsaturated permeable soils, the melt water percolates into the network of fissures and the pores, thus contributing to recharge the active layer. This water then flows laterally in contact with permafrost, depending on the permeability of the medium and the topography, to resurge at the base of slopes or into watercourse or lakes (GENIVAR, 2007a).

In rainy periods, the water infiltrates until contact with permafrost and then flows laterally at resurges at the base of the talus slope. In the hollows, the water mainly flows on the surface, either on the saturated soils or accessorially under the surface. In the latter case, the water flows much more slowly via the network of sand and gravel veins and lenses (GENIVAR, 2007a).

Slope Processes

Slope processes depend on the climate conditions and terrain of the study zone. In this continuous permafrost region, dry snow avalanche, slush flow and mollisol rupture phenomena are especially active.

In the study zone, three sectors are especially sensitive to avalanches. According to the NGI Sierra Neige report (2010), presented in Appendix 6, the most worrying sector due to its propensity for development of slush flow avalanches is located in the snow valley overlooking site Q1 (Map 6.2) . This type of avalanche, which is estimated to have a 100-year recurrence, is mainly triggered during spring thaws. The flows are known to be extremely erosive and have high sediment transport capacity. A destructive slush flow occurred very close to the Xstrata facilities in 2005 (Figure 6.3).

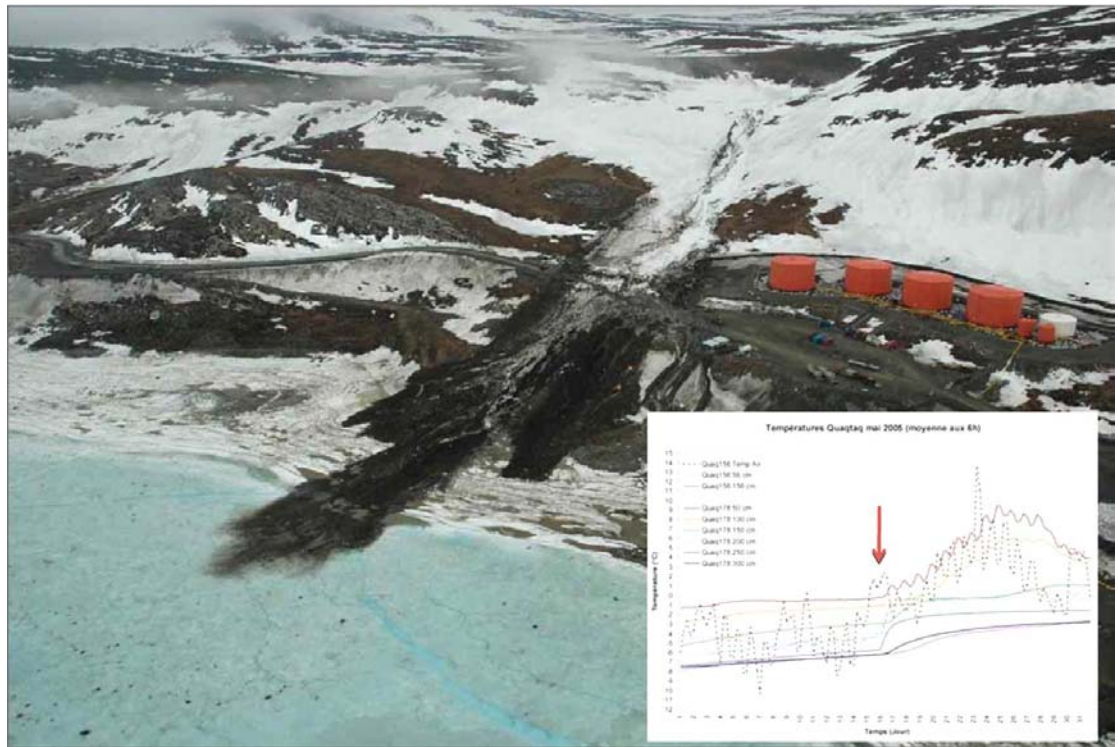

Figure 6.3 Debris cone from the 2005 slush flow, related to winter thaws (CEN, 2012).

The other two sectors identified are more conducive to dry snow avalanches (Map 6.2). These avalanches, which have no sediment stripping and transport capacity, are by far less destructive and smaller in scale than slush flows. The recurrence periods are estimated at about 1,000 years (Appendix 6).

Finally, mollisol ruptures mainly occur when the thaw reaches exceptional depths in the loose deposits, and especially in glaciomarine clayey silts. This type of deposit is particularly conducive to the growth of ice lenses. Since the permafrost ceiling is especially rich in ice, an enormous quantity of water that became liquid during the thaw period exerts a high interstitial pressure on the mollisol-permafrost interface, creating conditions favourable to mass movements. Mollisol ruptures could occur on slopes as shallow as 4° (L'Hérault, 2009). In the study zone, the aerial photographs taken in 2002 indicate that these processes are frequent, particularly on the southwest slope of the Deception River Valley, and along the terraces of the Bombardier Beach River paleodelta (Map 6.2).

6.1.3 Climate

According to the Québec climate classification, the climate of the Deception Bay region is qualified as a semi-arid polar temperature climate with a very short growing season (Gerardin and McKenney, 2001). Very little climate data is available for Nunavik near the study zone. Data is collected daily at the Salluit village airport, but the recording periods are limited to airport operating hours and few parameters are measured. An EC station was already in operation at Deception Bay from 1963 to 1973, but only precipitation and temperature were recorded. This data is 30 years old and probably does not reflect the current situation, due to climate change. Nonetheless, it is presented and compared with data from neighbouring stations.

6.1.3.1 Climate Means

Air Temperature

The annual mean temperature is -6.6°C , while the mean minimum and maximum temperatures are -9.7°C and -3.4°C respectively (Table 6.3). The coldest month is February (-25.1°C) and the warmest month is July (8.7°C). These mean temperatures seem higher than those measured at Salluit (L'Hérecault, 2009) and by interpolated data for the Iqaluit, Kuujuaq and Quaqtaq stations, all estimated at -8.0°C (Gray et al., 1988). Moreover, the temperatures measured at the Katinniq station (2000-2005) in the Raglan Mine region, give an annual mean of -9.5°C (GENIVAR, 2007). However, the altitude of the mine region is 300 m higher than Salluit, which explains in part why its annual mean temperature is lower.

Table 6.3 Monthly and annual mean temperatures at Deception Bay from 1963 to 1973.

Month	Air temperature ($^{\circ}\text{C}$)		
	Minimum	Mean	Maximum
January	-26.6	-23.3	-19.9
February	-28.5	-25.1	-21.7
March	-24.1	-19.9	-15.7
April	-14.3	-10.6	-6.9
May	-5.5	-2.4	0.7
June	0.5	3.2	5.9
July	4.6	8.7	12.7
August	4.5	8	11.5
September	0.8	3.4	5.9
October	-4.2	-2.1	0.0
November	-11.3	-8.7	-6.0
December	-20.5	-17.5	-14.5
Annual	-9.7	-6.6	-3.4

The number of degree-days at Iqaluit (Table 6.4), located at a latitude comparable to that of Deception Bay, indicates that the period favourable to vegetation growth is very short, limited to the period between late June and early September. The frost-free period is only 20 days (OPDQ, 1983 in FAPAQ, 2000).

Table 6.4 Number of degree-days at Iqaluit (Climate normals 1971 to 2000).

Month	> 10°C	> 5°C	> 0°C	< 0°C
January	0	0	0	824.1
February	0	0	0	792.5
March	0	0	0	735.9
April	0	0	0.5	443.5
May	0	0	10.8	146.5
June	1.4	21	112	4.8
July	10.4	88.2	237.7	0
August	5.5	64.1	210.9	0
September	0	5.3	75.8	10.8
October	0	0	5.7	156.7
November	0	0	0.6	381.8
December	0	0	0	700

Precipitation

Annual mean total precipitation in the Deception Bay region is 348.5 mm per year, including 129 mm of rain (37%) and 219.4 cm of snow (63%) (Table 6.5). The rainiest months are July and August. The snowfalls occurred from September to June, nearly every month of the year. Finally, the most abundant snowfalls occur in November, with a mean precipitation of 39.6 cm.

Table 6.5 Mean precipitation at Deception Bay from 1963 to 1973.

Month	Rain (mm)	Snow (cm)	Total liquid precipitation (mm)
January	0.0	15.5	15.5
February	0.0	13.7	13.7
March	0.0	18.4	18.4
April	0.0	28.4	28.4
May	2.7	14.4	17.1
June	17.6	17.1	34.7
July	39.8	0.0	39.8
August	38.9	0.9	39.8
September	22.9	13.7	36.6
October	6.7	32.2	38.9
November	0.5	39.6	40.1
December	0.0	25.5	25.5
Annual	129.1	219.4	348.5

The snow accumulations generally are disturbed by the wind and form compact. The snow accumulated on the exposed talus slopes and on the peaks is therefore blown to the more sheltered zones. The maximum thickness of the snow cover on the ground does not exceed one metre, on the average (FAPAQ, 2000).

6.1.3.2 Wind Regime

For the analysis of the wind regime, the data sources used come from the EC weather station at Salluit Airport and the Deception Bay data compiled from 1963 to 1973 (Figure 6.4). The data available at Salluit is only diurnal (between 6 a.m. and 8 p.m.) and often is deficient. However, this station is the one closest to Deception Bay and is located in a comparable environment (coastal bay). This is why the data coming from this station, although incomplete, is considered to be more representative than the data from other more remote stations located in different environments.

The dominant winds come from the southwest, with a frequency of about 34 %, and a cumulative frequency of about 17 % for the west/southwest and south/southwest directions. They are followed by winds from the north/northeast, with a frequency of about 13 %. The dominant south/southwest component corresponds to what was evaluated for Deception Bay by Roche (1992) (Figure 6.4). However, the northwest and southwest components are more prominent in Deception Bay, probably due to the similar orientation of the bay, contrary to Salluit, which is oriented northeast/southwest.

6.1.3.3 Sea Ice

The Canadian Ice Service publishes charts presenting the average freeze-up and break-up dates for the Canadian North, and particularly for Hudson Strait. These charts use data for 1981-2010 and illustrate that the Deception Bay sector is subject to an ice regime for the average period between December 4 and July 2. In short, the sector is accessible by waterway for a period of about five months, except for icebreakers (Figure 6.5).

Figure 6.6 presents the annual total accumulated ice coverage of Hudson Strait, i.e. the percentage representing the total surface of ice cover in relation to the total surface of the water body. The average percentage of the total accumulated ice coverage for Hudson Strait is about 50% for the last 41 years.

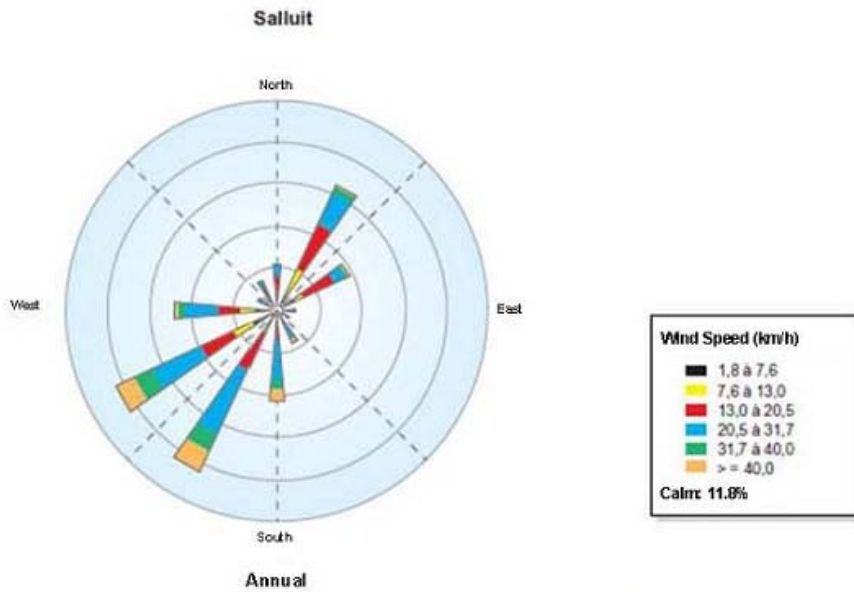
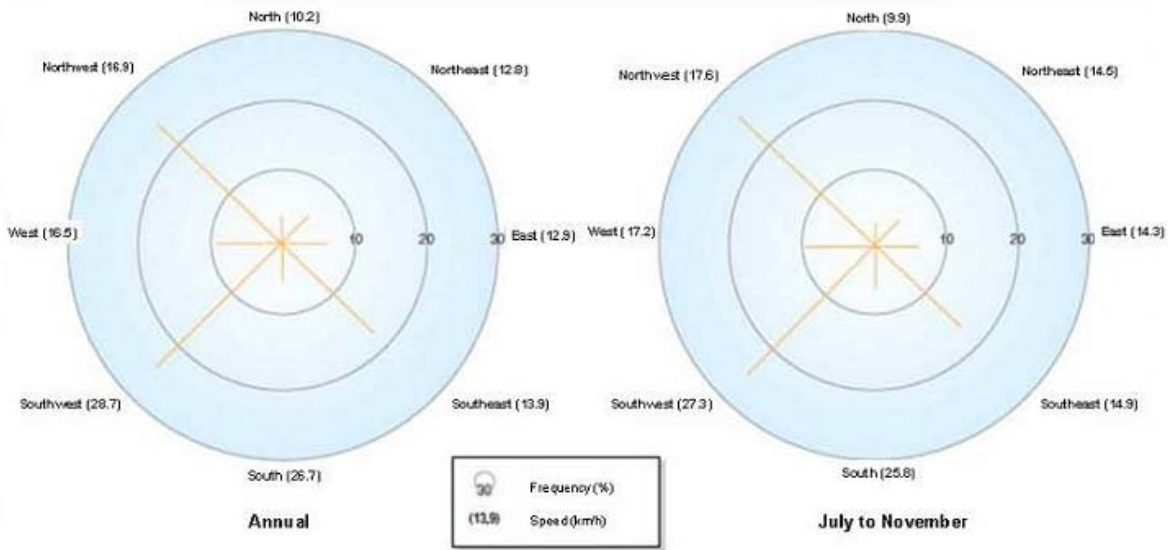

Notes: Deception Bay wind roses modified from Roche (1992 b)
 Deception Bay (1963-1973)
 Salluit (2002-2006)

CANADIAN ROYALTIES inc. GENIVAR

Figure 6.4 Wind roses for Deception Bay and Salluit

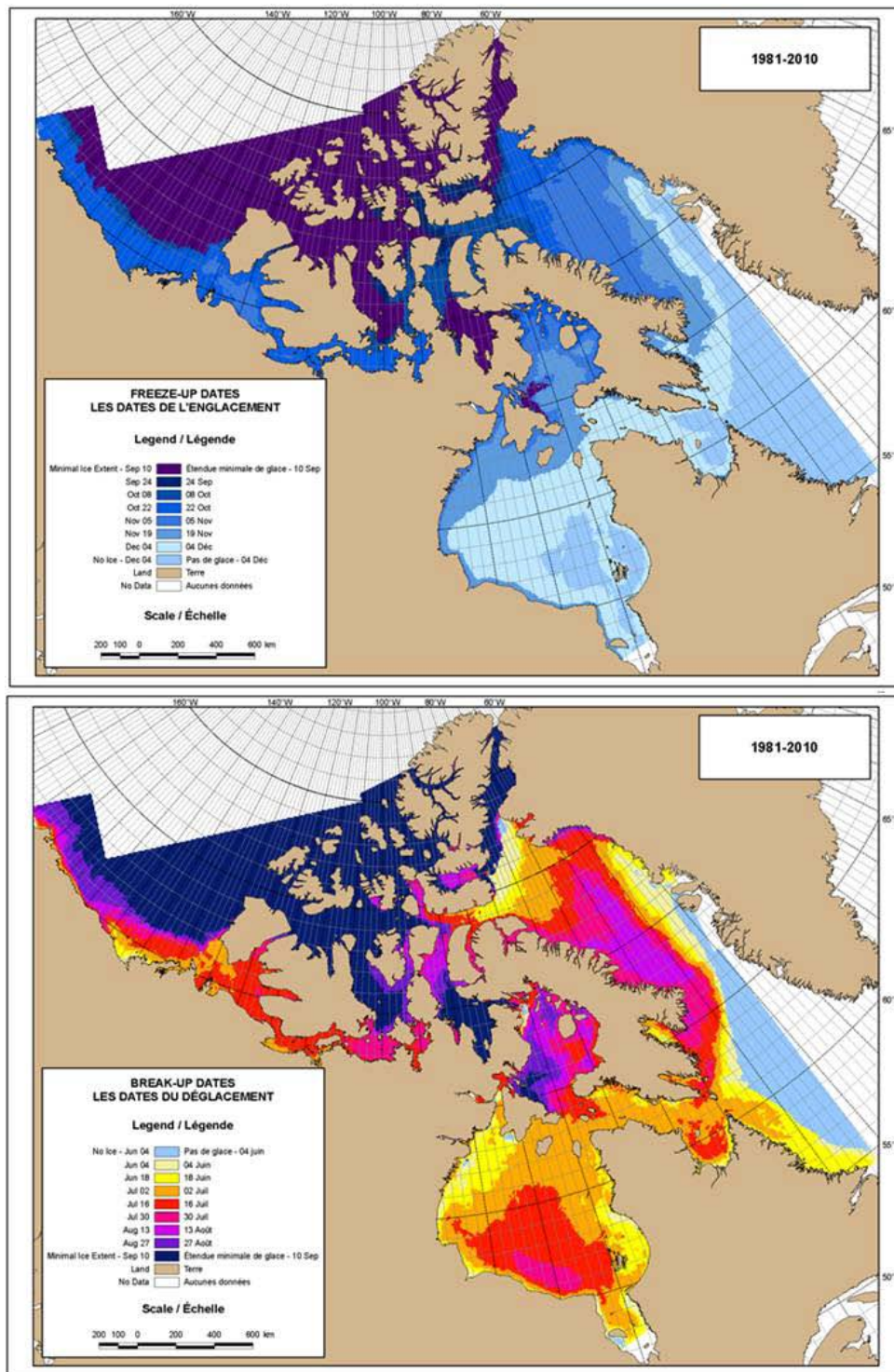

Figure 6.5 Freeze-up and break-up dates for the Arctic region (Environment Canada, 2012)

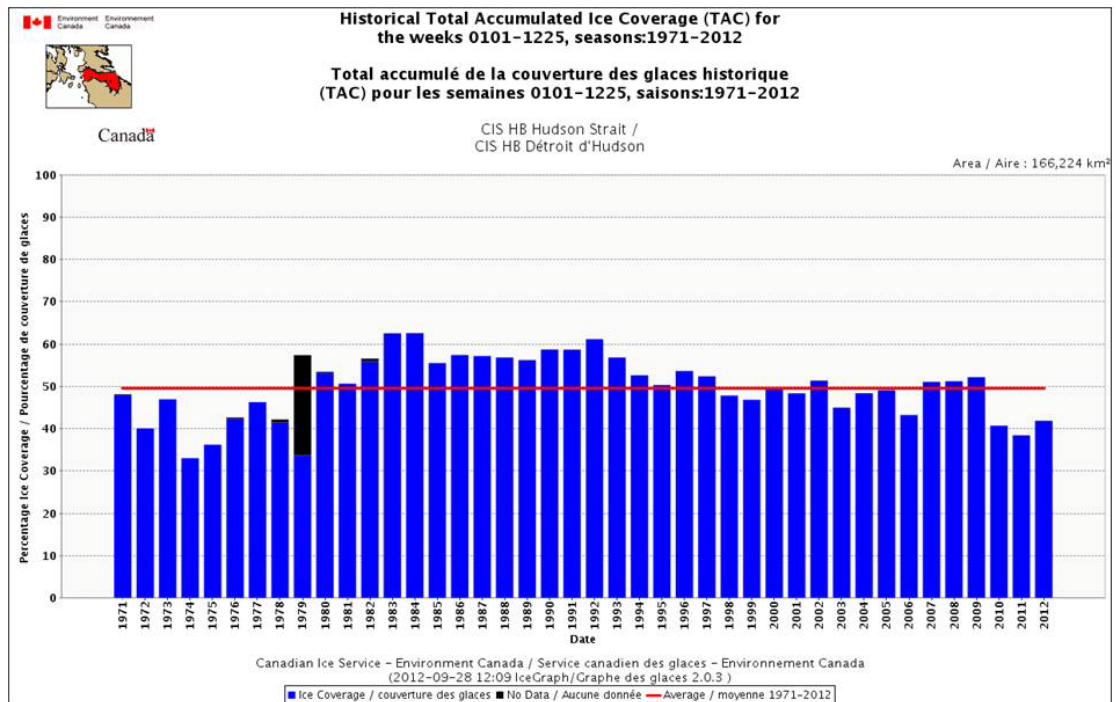

Figure 6.6 History of the percentage of ice coverage in the Hudson Strait sector

6.1.3.4 Climate Change and Outlooks

Climate

Seasonal temperature and precipitation changes in Nunavik have been estimated by the Ouranos Group for years 2020 and 2050. The temperature values and the rate of change of precipitation are projections drawn from several general circulation models for various greenhouse gas emission scenarios. According to the results of the modelling performed by Ouranos, the rise in mean temperatures on an annual basis would be 1 to 3°C and 5 to 6°C respectively for the years 2020 and 2050 (Table 6.6) (Ouranos, 2007). Winter, and to a lesser extent spring, are the seasons for which the temperature rises could be the most significant (Table 6.6). These values are comparable to the 2.85°C temperature rise calculated based on regression of the mean temperatures at the Inukjuak station during the 20th century (Tremblay and Furgal, 2008). For precipitations, the projected mean variations are -2% to +19% and 0 to +31% for the years 2020 and 2050, respectively (Table 6.7). Winter and spring are the seasons most likely to show the most significant variations in their precipitation (Table 6.7). Summer precipitation could be lower.

Table 6.6 Anticipated warming of temperatures in Nunavik for 2020 and 2050, relative to the data for the 1980s (modified from Ouranos, 2007).

Years	2020	2050
	Warming (°C)	Warming (°C)
Winter	+2 to +4	+4 to +10
Spring	0 to +3	+1 to +5
Summer	+1 to +2	+2 to +4
Fall	+1 to +3	+2 to +4
Annual	+1 to +3	+5 to +6

Table 6.7 Anticipated variation of precipitation in Nunavik for 2020 and 2050, in relation to the data for the 1980s (modified from Ouranos, 2007).

Years	2020	2050
	Variations (%)	Variations (%)
Winter	0 to +25	0 to +50
Spring	0 to +15	0 to +30
Summer	- 5 to +15	-5 to +20
Fall	0 to +20	5 to +25
Annual	-2 to +19	0 to +31

Modification of Geomorphological Processes

In general, warming temperatures and snowfall and rainfall variations have multiple consequences for the dynamics of northern environments. These environments are considered to be especially sensitive, mainly due to the presence of permafrost, the melting of which is considered to activate many geomorphological processes.

Permafrost melting is not only associated with rising air temperatures, but also with the growing availability of liquid phase water circulating in the soil and its thermal diffusion in frozen ground. In addition, due to its insulating power, the increase in snow accumulations on the ground or changes in distribution of the snow cover can alter the conditions of soil penetration by the frost front and cause local permafrost melting.

Many studies show that climate warming is already making a sudden appearance in Nunavik, even in the very short term. For example, for the period from 1987 to 2004, the thickness of the mollisol at Salluit increased from 2.2 m (Lévesque *et al.*, 1990) to about 3.05 m in the bedrock, and from 1.30 m to over 1.40 m in the till (L'Hérault, 2005). The most worrying phenomenon in the Salluit region is the increase in the thickness of the mollisol in the extremely ice-rich silty clay deposits of glaciomarine origin, which increased from 82 cm in 1992 to 107 cm in 2007 (L'Hérault, 2009).

Warming on this scale leads to permafrost degradation, triggering differential subsidence in the ice-rich deposits and increasing the risks of landslides on the favourable slopes. Permafrost degradation represents significant risks for all infrastructures and establishments erected in permafrost zones. In the Salluit Valley, two landslides, occurring in 1998 and 2005, caused major damage to village's establishments and infrastructures (L'Hérault, 2009).

Finally, apart from the increased risk of landslides, climate change could cause overall alterations in the hydrological regime of the lakes and rivers, the freeze-up periods, the thinning of the ice, and earlier melting of the ice covering the water masses and the snow cover. These alterations will trigger changes in the hydrosedimentary and glacial processes.

Climate warming could also trigger an increase in the frequency and intensity of other geomorphological processes, animated by more frequent winter thaw periods and alteration of the snow cover. Thus, the increase in the frequency and intensity of avalanche and slush flow phenomena becomes especially worrying. Slush flows are all the more likely to transport large quantities of sediments, because permafrost melting leads to the availability of enormous quantities of sediments mobilizable by such processes.

Assessment of Eustatic Variation

Since the early 1970s, the average sea level rise observed has been around ten centimetres, or about 2.5 mm/year (it should be noted that this rise is extremely variable depending on the geographical location. The IPCC projections (IPCC, 2007), according to various temperature increase scenarios by the 2090-2099 horizon (from +0.6 to + 4°C), range from 0.18 m to 0.59 m (2 to 6.5 mm/year). For the same time horizon, other models indicate higher mean annual rises (from 5.6 to 20.45 mm/year) and a greater rise range (from +0.5 to +1.8 m by the 2100 horizon). The rise would be sharper in the second half of the 21st century.

On the other hand, glacio-isostatic uplift in Nunavik, which is variable in intensity over time and which occurs in the very long term (thousands of years) would be around 6 to 14 mm/year (Beaulieu and Allard, 2003; Lavoie and Allard, 2008). Considering the sea level rise scenarios up to 2100, there is reason to believe that, in the decades ahead, the Nunavik shoreline will continue to emerge, greatly reducing the risks related to coastal erosion.

6.1.4 Physical Oceanography

Two physical oceanographic survey campaigns were conducted in Deception Bay: August to September 2006 and August to September 2012. Tides and water levels, waves, flow and currents, physicochemistry and water quality were characterized for these two periods in order to describe the oceanographic conditions in Deception Bay.

6.1.4.1 Tides and Water Level

There are few records of the water level in the Deception Bay region. The tidal characteristics established based on the water levels measured during the 2012 survey campaign are used to describe the tide at the study site (Figure 6.7). The tide that enters Deception Bay is semi-diurnal, meaning that it presents two complete oscillations per day, i.e. two high waters (high tide) and two low waters (low tide). Each oscillation extends over an average period of 12 hours and 25 minutes.

Tidal Characteristics

Harmonic analysis of the water levels measured in 2012 (GENIVAR, 2012a) allows the establishment of a series of hourly values, which is used to establish the tidal characteristics (Table 6.8). The tidal range of 3.9 m for mean tides and 5.7 m for large tides is relatively large. The mean water level is 2.9 m and the higher high water large tide (HHWLT) is 5.8 m (Table 6.8).

Storm Surge Observed in Deception Bay

The analysis of the atmospheric component of the water levels measured indicates a mean variation of around 20 cm and a significant rise of the mean water level around mid-September 2012 (Figure 6.8). This rise of around 60 cm is due to the passage of a major depression. On September 13, the winds reached more than 30 km/h and the barometric pressure was below 98 kPa (Table 6.9). The combination of the passage of a depression associated with high winds and large tides causes extreme tidal events.

6.1.4.2 Waves

The wave measurements taken in 2006 (Figures 6.9 and 6.10) show that the significant height (H_s) never exceeded 0.8 m. Assuming a Rayleigh distribution, it is possible to apply a conversion factor of 1.87 for H_{max}/H_s (Komar, 1998) in order to determine the maximum height of the waves. This was estimated at 1.5 m during the measuring period.

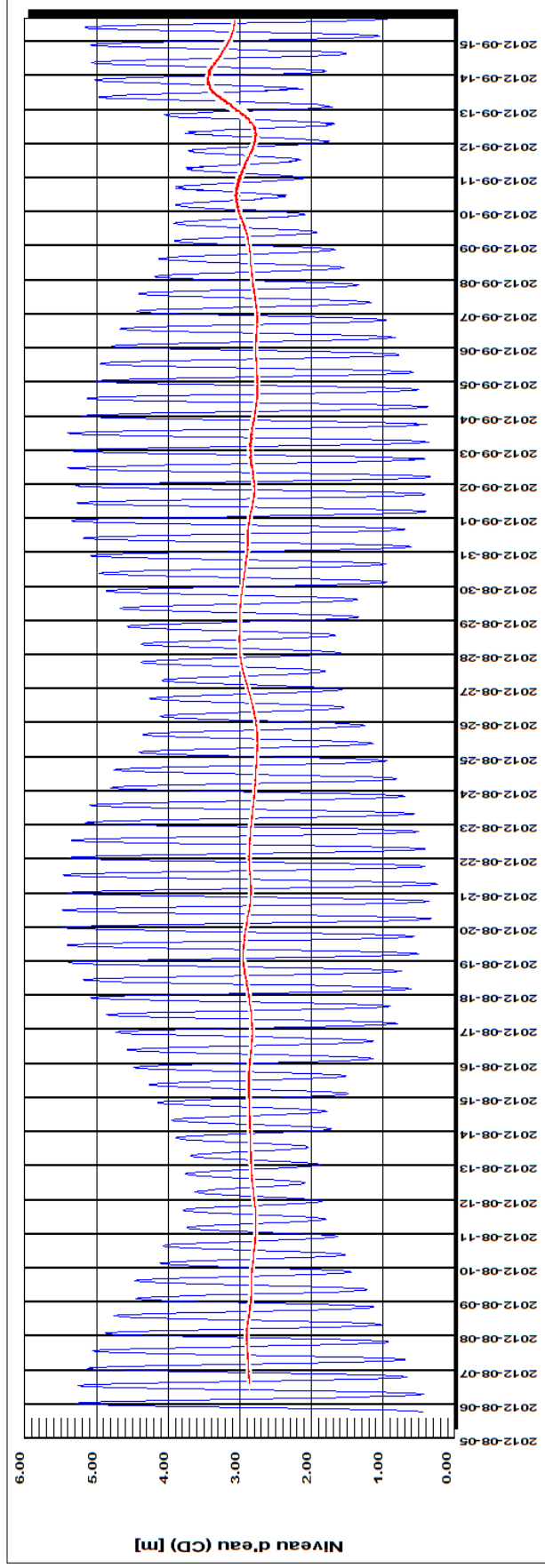

Figure 6.7 Water level measured in Deception Bay between August 8 and September 15, 2012 (CD). The red line shows the bay water level variation caused by the passage of atmospheric disturbances. The levels are all represented relative to the Chart Datums.

Table 6.8 Deception Bay tide table

Characteristic		(m, CD) ¹
Higher high water large tide	HHWLT	5.8
Higher high water mean tide	HHWMT	4.9
Mean water level	MWL	2.9
Lower low water mean tide	LLWMT	0.9
Lower low water large tide	LLWLT	0.1
Mean tidal range		3.9
Large tidal range		5.7
Extreme high water ²		5.8
Extreme low water ²		0.0

¹ Values expressed relative to the Tide Gauge Bench Mark

² Predicted values

Table 6.9 Weather conditions observed at Salluit Airport on September 13 and 14, 2012 (Environment Canada, 2012).

Date and time	Pressure (kPa)	Wind intensity (km/h)	Wind direction (°)
2012-09-13 7 h	96.49	52	340
2012-09-13 8 h	96.67	33	350
2012-09-13 9 h	96.93	39	340
2012-09-13 10 h	97.11	28	330
2012-09-13 11 h	97.26	39	330
2012-09-13 12 h	97.4	46	330
2012-09-13 13 h	97.53	41	310
2012-09-13 14 h	97.66	33	300
2012-09-14 7 h	98.87	19	240
2012-09-14 8 h	98.89	22	230
2012-09-14 9 h	98.91	37	230
2012-09-14 10 h	98.91	28	230
2012-09-14 11 h	98.92	28	230
2012-09-14 12 h	98.89	33	220
2012-09-14 13 h	98.81	46	240
2012-09-14 14 h	98.8	33	240

These values are evidence of a period of violent winds from the southwest, which swept the bay at the beginning of September. These winds seem to have been constant on the coast of the Ungava Peninsula, because similar data was recorded at Salluit. Despite winds generally higher than 50 km/h, the waves were lower than 2 m. Winds exceeding 40 km/h occur about 7% of the time at Deception Bay.

Also according to the 2006 data, the wave period is generally less than 7 s, and only a few rare sequences showed wave periods exceeding 8 s (Figures 6.9 and 6.10). These short periods suggest that the waves are generated locally by the wind and are not the result of propagation of the swell formed at high water.

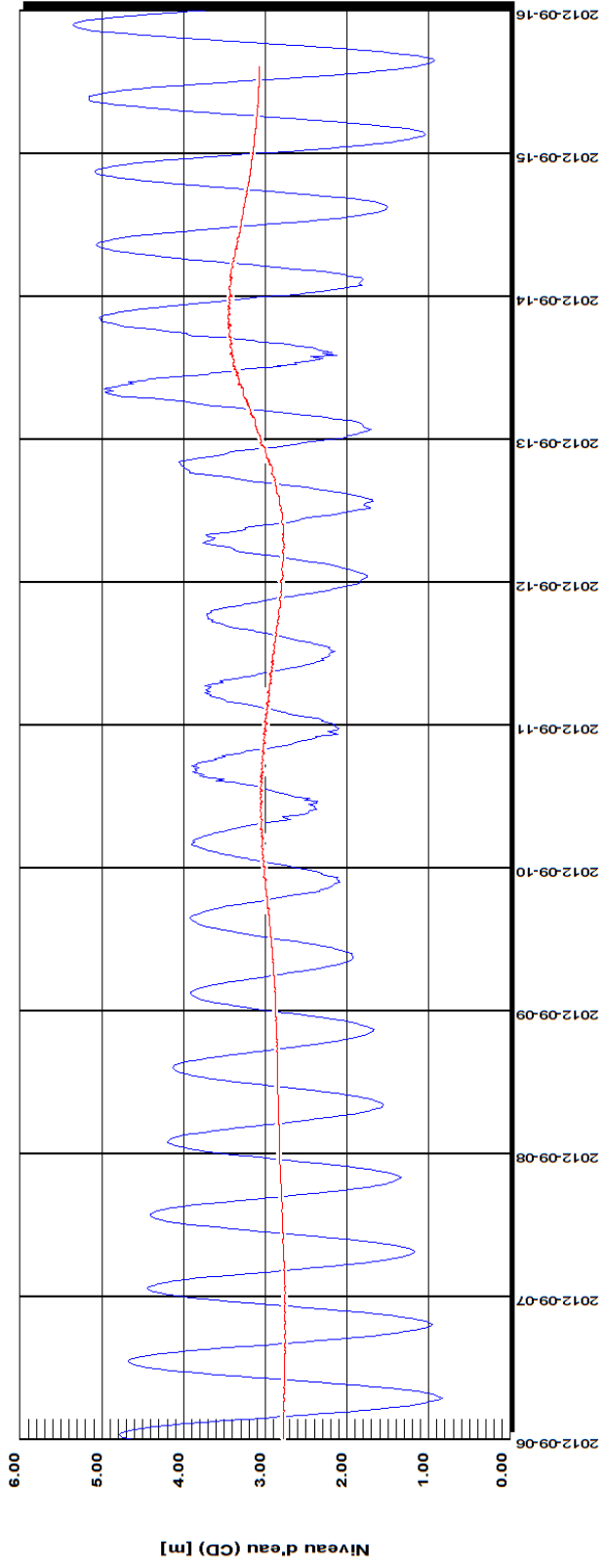

Figure 6.8 Variation of the water level in Deception Bay between September 6 and 16, 2012 (CD). The line represents the atmospheric component of the water levels measured.

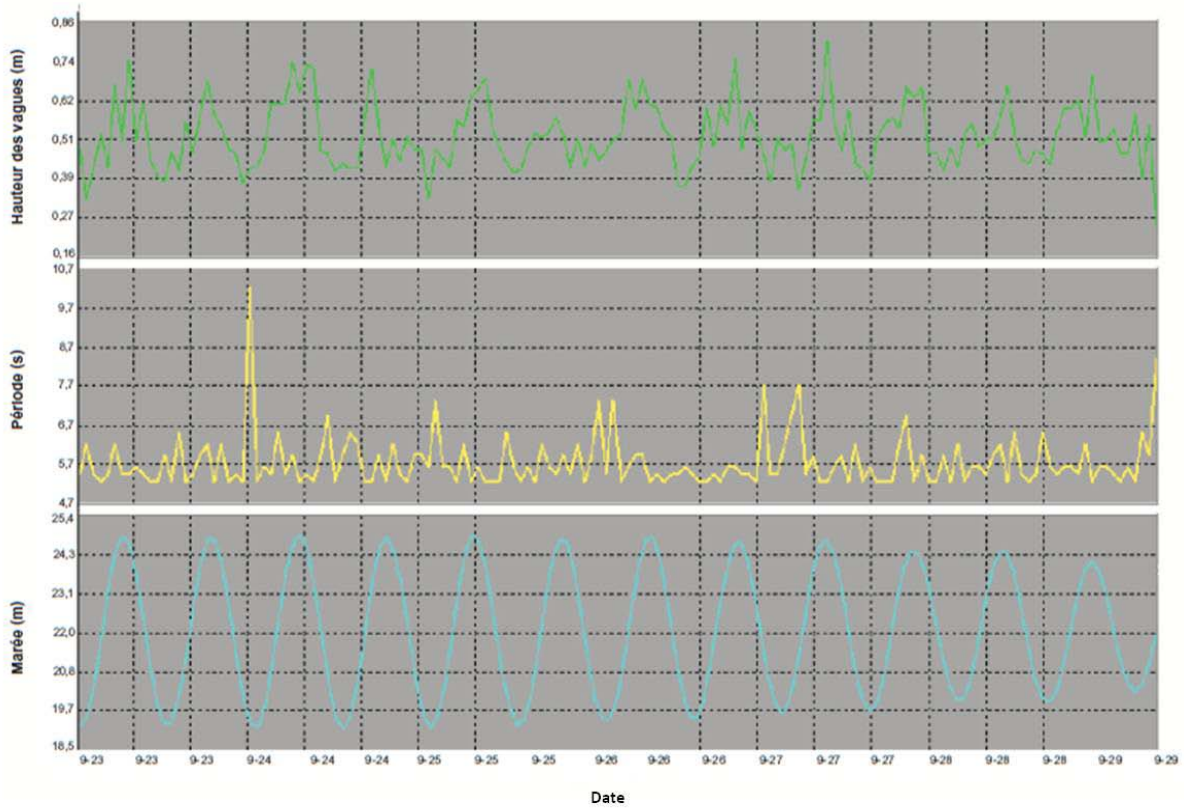

Figure 6.9 Recorded series of the significant height of waves, their period and the tide measured between September 5 and 22, 2006 (modified from GENIVAR, 2007a).

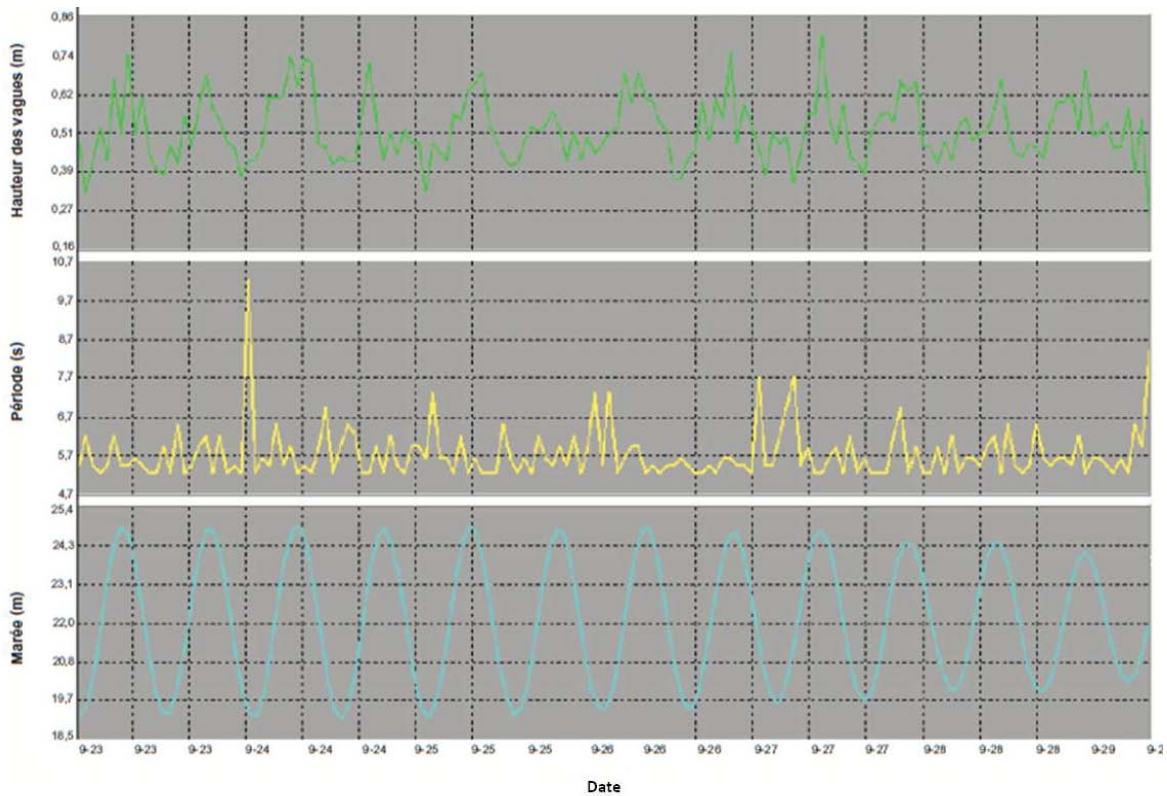

Figure 6.10 Recorded series of the significant height of the waves, their period and the tide measured between September 22 and 29, 2006 (modified from GENIVAR, 2007a).

6.1.4.3 Flow and Currents

A currentometric characterization of Deception Bay was conducted in 2012 and is the subject of the sector report presented in Appendix 7 (GENIVAR, 2012a).

The flow variations of the water masses in Deception Bay are generally associated with the tidal effect, in addition to local effects near the shores, such as those associated with breaking waves. Finally, wind plays a significant role in the surface currents and in shallow zones.

The mean current speeds are low (< 100 mm/s), at all depths (Figure 6.11). The maximum speeds recorded are generally less than 250 mm/s, except at ebb tide (falling tide), while the surface currents occasionally may reach speeds exceeding 500 mm/s (Table 6.10). The highest speeds are associated with surface waters, although on one occasion, at the beginning of September, the current speed in the middle of the water column exceeded 250 mm/s.

Table 6.10 Descriptive statistics of current speed different depths in Deception Bay between September 5 and 29, 2006.

Distance from the bottom (m)	Mean speed (mm/s)	Standard deviation (mm/s)	Maximum speed (mm/s)
10.5	97	74	853
6.8	54	36	318
3.0	43	27	253

On August 1, 2 and 3, 2012, currentometric surveys were conducted with an ADCP (Acoustic Doppler Current Profiler) along two transects (Map 5.2) through Deception Bay, in order to measure the instantaneous speed of the currents (Figures 6.12 and 6.13). The white zones are attributable to the low turbidity of the water and the low concentration of suspended particulate matter, from which the device measures the current speeds (Figure 6.12). A clear trend emerges for current speeds exceeding 0.4 m/s (Figure 6.12) near the right shore, in proximity to Pointe-Noire (Section T1, Map 5.2). This effect is attributed to local acceleration of current speed associated with the presence of a rocky notch to right of Pointe-Noire and the presence of a shoal downstream from the left shore. In short, a significant fraction of the flow associated with the tidal prism passes near Pointe-Noire. The currentometry in Section T2 seems more uniform through the section (Figure 6.13).

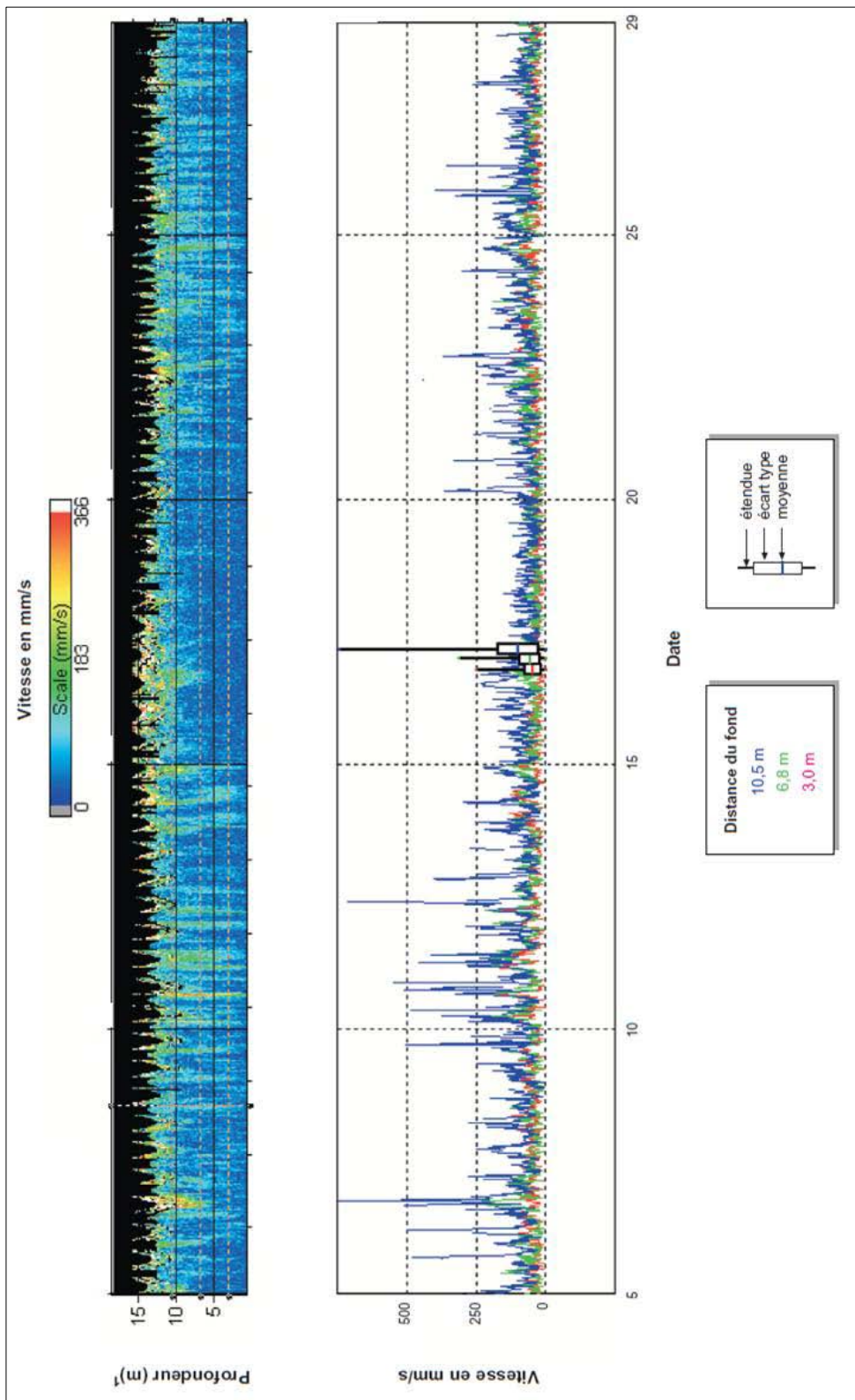

Figure 6.11 Current speeds measured between September 5 and 29, 2006 at station 1200 located at a depth of 11 m. The bottom portion shows the speeds at 10.5 m, 6.8 m and 3.0 m.

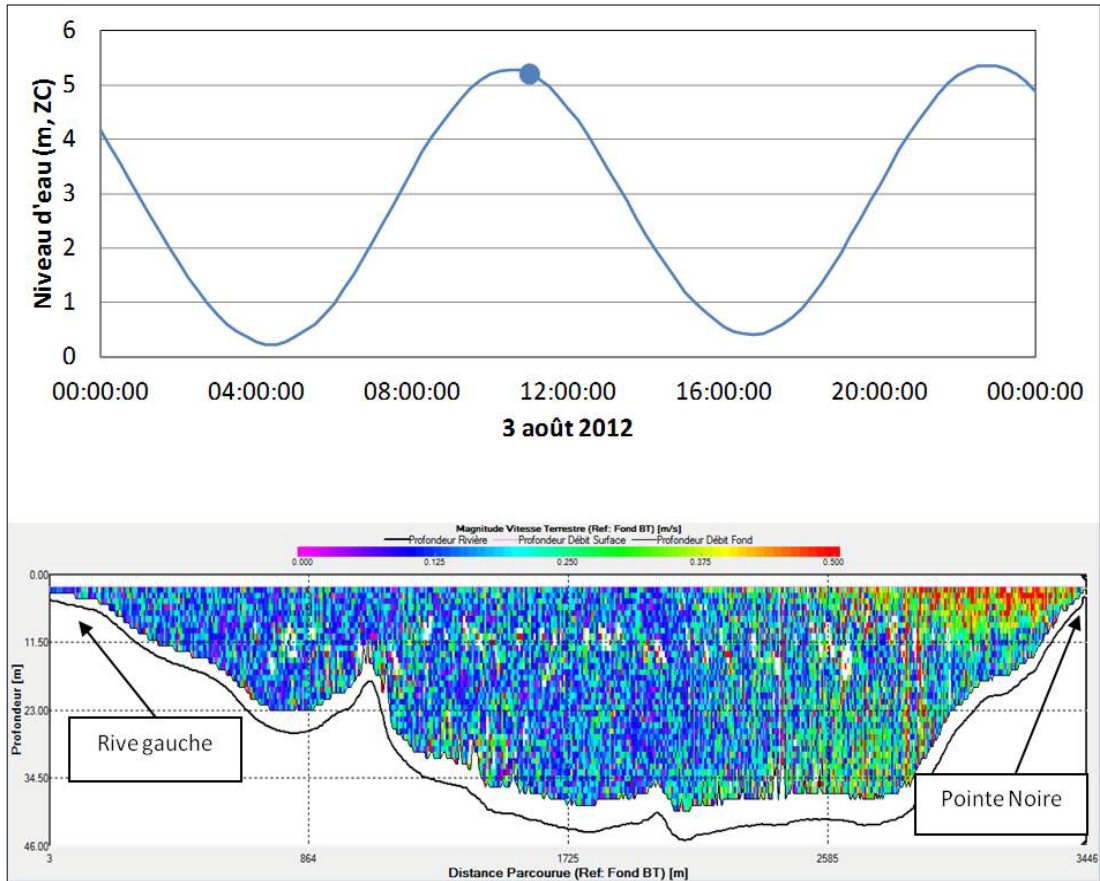

Figure 6.12 Currentmetric profile produced in Section T1, August 3, 2012

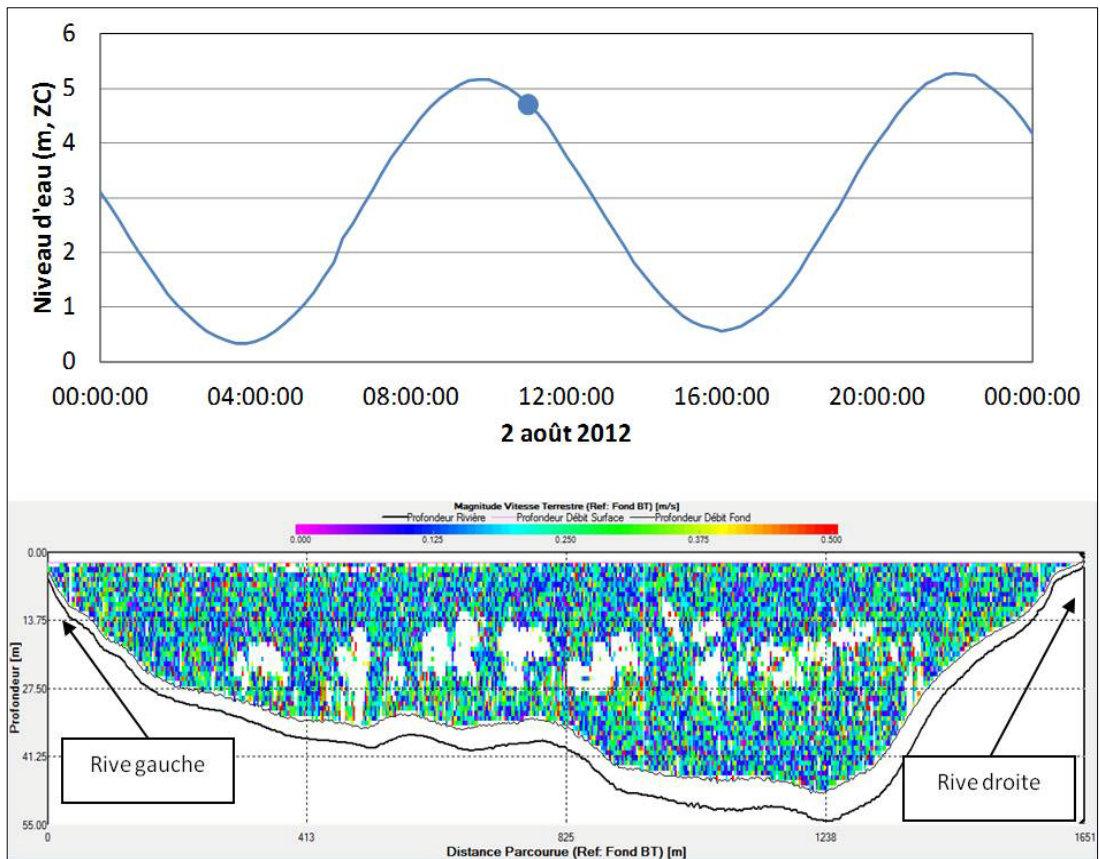

Figure 6.13 Currentmetric profile produced in Section T2 – August 2, 2012

Drifters

During the campaign of August 1, 2 and 5, 2012, drifters fitted with a sheet metal cross brace located 1 m or 3 m below the surface of the water reacted the same way, except for the distances travelled. Indeed, the drifters placed 3 m below the surface of the water travelled shorter distances than those placed 1 m below the surface, because they snagged on the bottom (Map 6.3).

In front of sites Q1 and Q2, the surveys of August 1 and 2 show northwest directions during ebb tide, while the directions during flood tide are south-southeast, the opposite direction (Map 6.3). The mean drift speed recorded during these days was 53 mm/s, which is considered relatively low (Table 6.11). The wind conditions then were from the northwest, with a speed of less than 20 km/h.

Table 6.11 Drifter displacement speeds near sites Q1 and Q2.

	August 1	August 2	August 5
Maximum speed (mm/s)	260	102	277
Mean speed (mm/s)	65	41	127
Standard deviation (mm/s)	60	27	59

However, the drift direction for August 5 was northwest or northeast during the flood tide. These directions are completely opposite those recorded during this tidal phase on the preceding days (Map 6.3). The mean speed recorded by the drifters on August 5 was 127 mm/s, more than double the mean speed recorded on August 1 and 2 (Map 6.3; Table 6.11). The winds blew much stronger from the south-southeast, contrary to the conditions on August 1 and 2. These results show that the wind can easily counter the influence of the tide and completely change the direction and speed of the currents, at least within the first three metres below the surface of the water in front of sites Q1 and Q2.

The trajectories recorded on August 2 in front of the CRI temporary camp during ebb tide indicate a southerly direction, towards the shore (Map 6.3). At flood tide, the directions are either southeast (towards the shore), or east (towards the mouth of the Deception River) (Map 6.3). These results show that the tidal influence during ebb tide is weaker at this location in front of sites Q1 and Q2.

Finally, the mean displacement speed of the drifters on August 2 offshore from the CRI temporary camp was 34 mm/s. The maximum speed recorded on that day was 109 mm/s, during flood tide, which may indicate that the displacement speeds are slower at ebb tide (Table 6.12).

Trajectoire des dériveurs les 1, 2 et 5 août 2012 et aperçu des conditions hydrodynamiques / Trajectory of Drifters on August 1, 2 and 5, 2012 and Outlook of Hydrodynamic Conditions

Projection : UTM, zone 18, NAD83

Source :
Base : Photographies aériennes (1 : 10 000) / Aerial photographs (1:10 000) (Q02201-115 et Q02201-117)

Inventaires et cartographie / Surveys and mapping : GENIVAR
Fichier / File : 101_53046_EIES_BD_c6_3_dérives_121120.mxd

Novembre / November 2012
101-53046-02 GENIVAR

Trajectoire et direction de la dérive / Trajectory and direction of drift

- Dérive 1 à 3 (1 m) / Drift 1 to 3 (1 m)
- Dérive 4 à 6 (3 m) / Drift 4 to 6 (1 m)

Composante du projet / Project Component

- ☐ Infrastructures portuaires projetées (variantes) / Proposed wharf (variants)
- ☑ Site de dépôt des sédiments (variantes) / Sediment disposal site (variants)
- ☐ Zone d'étude / Study area

Infrastructures existantes / Existing Infrastructure

- ☑ Campement Inuit permanent / Inuit permanent camp
- ☑ Infrastructures portuaires / Wharf
- Route / Road

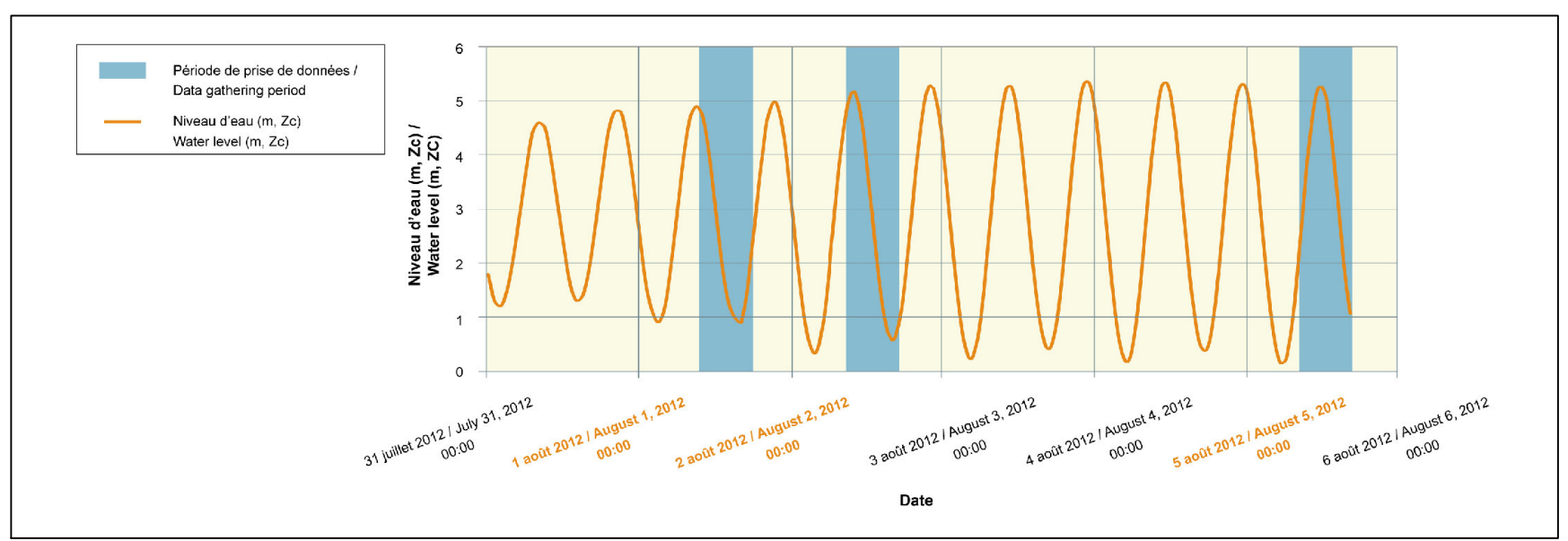
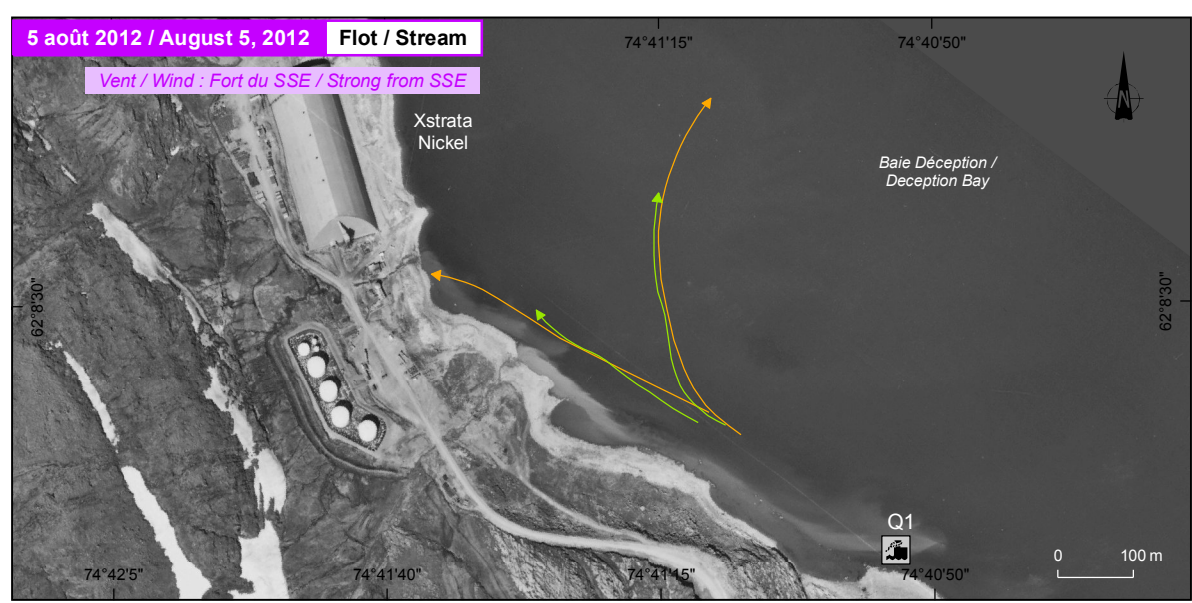
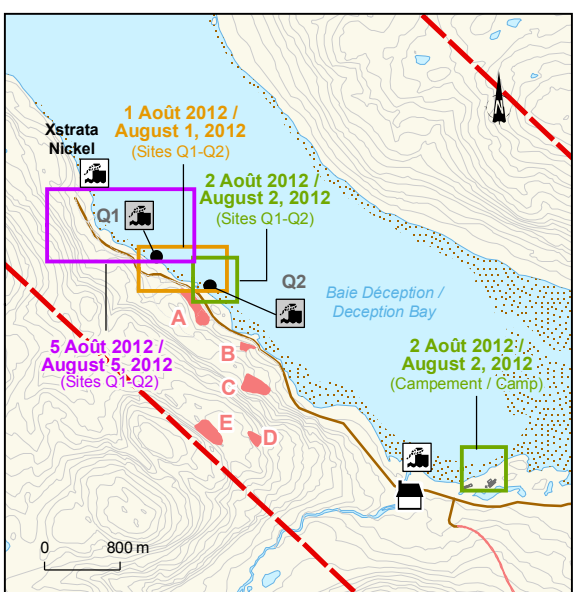
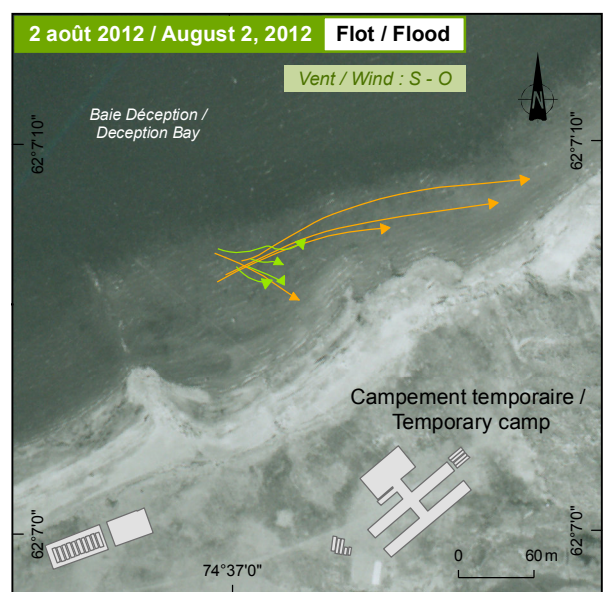
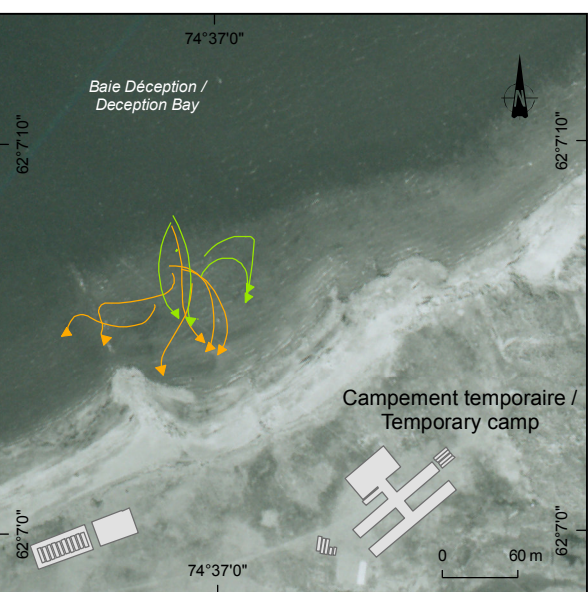
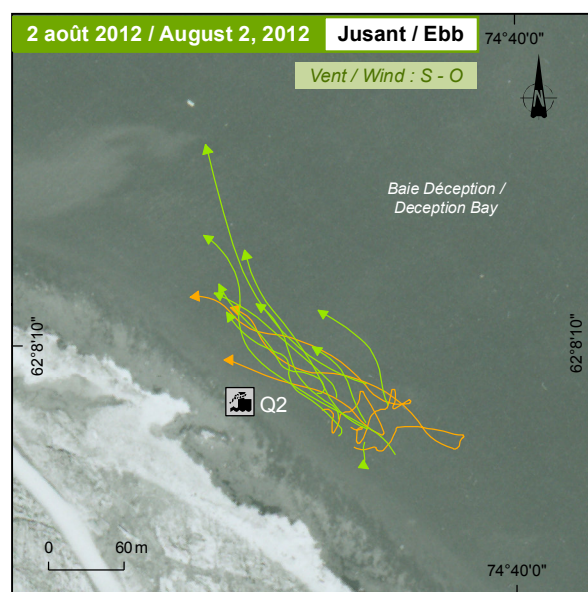
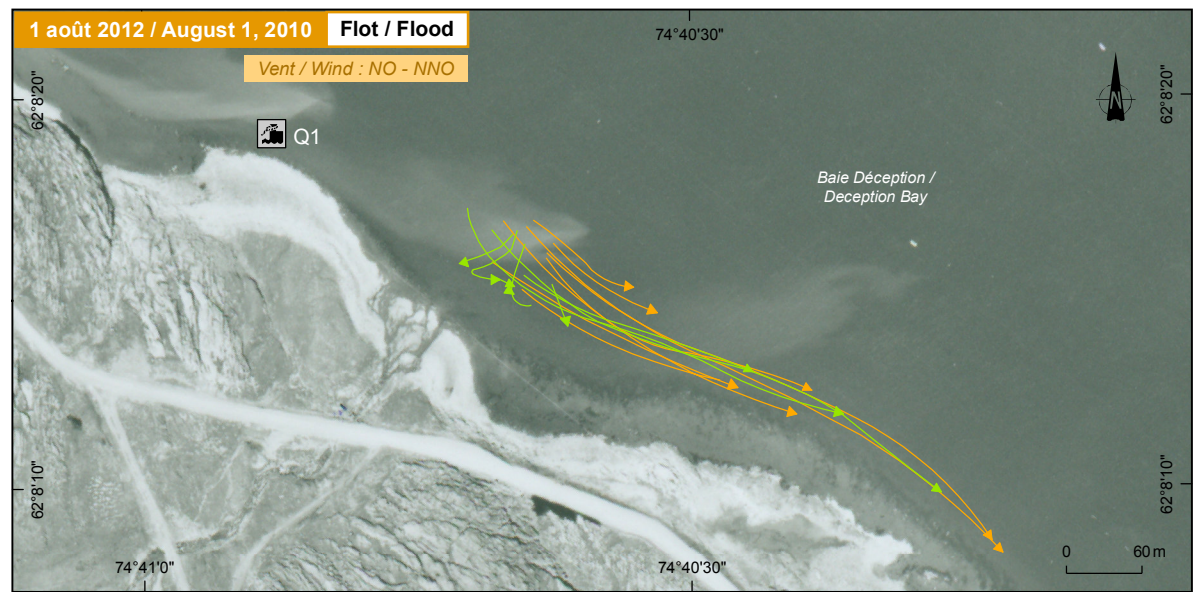
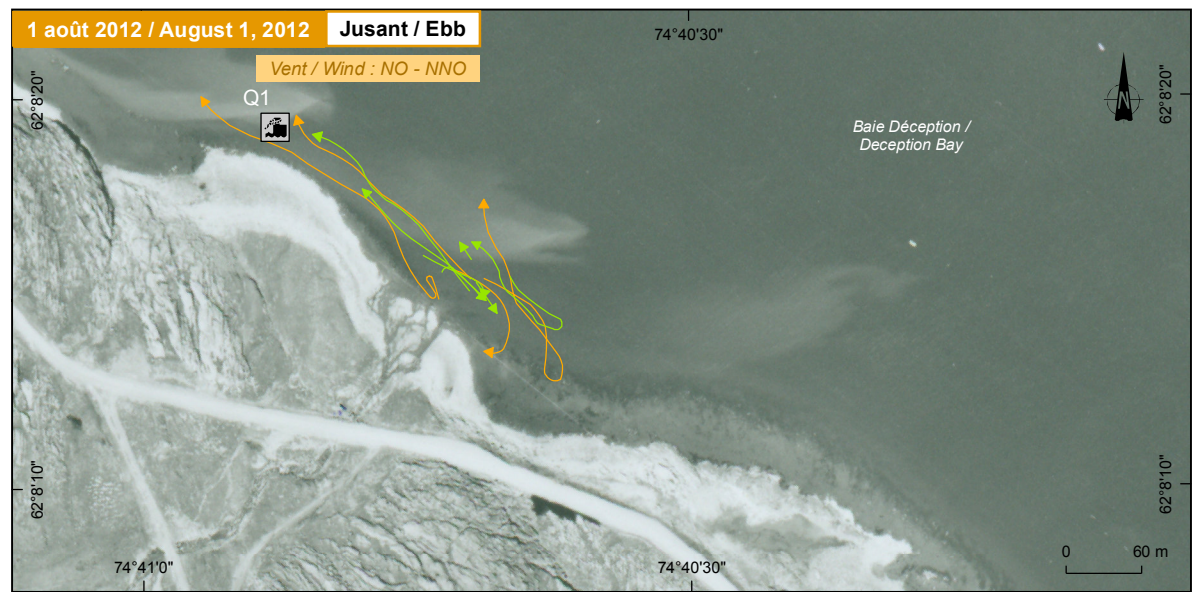

Table 6.12 Displacement speeds of drifters offshore from the Canadian Royalties camp on August 2, 2012.

	mm/s
Maximum speed	109
Mean speed	34
Standard deviation	29

6.1.4.4 Water Physicochemistry

Several vertical profiles of water physicochemistry were produced from August 1 to 5, 2012 (Map 5.2). The results were compared with similar profiles produced in 2006 in Deception Bay (GENIVAR, 2008). The profiles show that the influence of fresh water from the Deception River is variable from one location to another and that these variations also depend on seasonal wind and streamflow conditions. The sector facing sites Q1 and Q2 is visibly influenced by the arrival of fresh water from the river, and this plume can be noticed up to 5 km from the river mouth (GENIVAR, 2008).

The result of this surface water layer from the river is to stratify the water column into three distinct layers: 1) the surface layer with warm temperatures (5.5°C) and slightly lower salinity (29 ppm); 2) the intermediate layer, where the temperature decreases and salinity increases more sharply; 3) the deep water layer, with the highest salinity values (31 to 33 ppm) and the lowest temperatures (nearly 3.5°C) (Table 6.13).

Table 6.13 Temperature and salinity values of deep water layer of Transect 1 (August 2012).

Depth (m)	Temperature (°C)	Salinity (ppm)
10.34	4.70	33.66
12.76	4.50	33.67
17.83	4.30	33.49
17.83	4.30	33.49
20.45	4.20	33.53
20.45	4.20	33.53
23.12	4.00	33.43
27.95	3.40	33.03

Stratification may vary during spring flood, when the river's influence is much greater, or in fall due to stronger winds. This favours mixing of the surface layer with the intermediate layer.

The turbidity data indicates that there was very little variability during the 2012 sampling campaign, with values practically at zero all along profiles. The visual observations also confirm the notable transparency of the water of Deception Bay.

Suspended Particulate Matter

Integrated water samples were collected: 20 offshore from sites Q1 and Q2, three at the mouth of the Deception River, and two in front of the CRI temporary camp (Map 5.3) (Table 6.14). All the surveys were conducted at a distance of less than 200 m from the shore and at water depths of less than 15 m. In general, the SPM concentration for all stations ranged from 1 to 19 mg/L, with maximum values at the mouth of the Deception River (station BD12)

Table 6.14 Concentration of suspended particulate matter measured near sites Q1 and Q2, August 5, 2012.

Station	Site	Date	Time	Tide	Integrated SPM (mg/L)
BD01	Q1	2012-08-05	09:44	Flood tide	10
BD02	Q1	2012-08-05	09:47	Flood tide	11
BD03	Q1	2012-08-05	09:53	Flood tide	17
BD04	Q1	2012-08-05	10:00	Flood tide	13
BD05	Q1	2012-08-05	10:05	Flood tide	10
BD06	Q2	2012-08-05	10:19	Flood tide	11
BD07	Q2	2012-08-05	10:23	Flood tide	11
BD08	Q2	2012-08-05	10:44	Flood tide	12
BD09	Q2	2012-08-05	10:49	Flood tide	10
BD10	Q2	2012-08-05	10:52	Flood tide	11
BD11	RIV	2012-08-05	11:46	Slack water	12
BD12	RIV	2012-08-05	11:47	Slack water	19
BD13	RIV	2012-08-05	11:50	Slack water	13
BD14	Q1	2012-08-05	15:33	Ebb tide	15
BD15	Q1	2012-08-05	15:36	Ebb tide	1
BD16	Q1	2012-08-05	15:39	Ebb tide	2
BD17	Q1	2012-08-05	15:41	Ebb tide	1
BD18	Q1	2012-08-05	15:44	Ebb tide	2
BD19	Q2	2012-08-05	16:06	Ebb tide	4
BD20	Q2	2012-08-05	16:09	Ebb tide	2
BD21	Q2	2012-08-05	16:12	Ebb tide	3
BD22	Q2	2012-08-05	16:14	Ebb tide	6
BD23	Q2	2012-08-05	16:16	Ebb tide	3
BD24	CAMP	2012-08-05	16:50	Ebb tide	2
BD25	CAMP	2012-08-05	16:53	Ebb tide	3

The SPM concentration in the water column near sites Q1 and Q2 is greater during flood tide. The mean of 11.6 mg/L is three times greater than the mean value calculated during ebb tide (3.7 mg/L) (Table 6.15). However, the wind conditions were extremely variable during the day. Strong winds were blowing during the morning of August 5, which corresponds to the time when the highest SPM concentrations were observed.

Table 6.15 Descriptive statistics on suspended particulate matter near sites Q1 and Q2 (August 5, 2012)

SPM values (mg/L)	Flood tide	Ebb tide
Maximum	17	15
Mean	11.6	3.7
Standard deviation	2.1	3.8

Under the influence of the wind, the waves suspended the shore sediments, which increased the SPM concentration. This phenomenon was observed throughout the water column, within 200 m of the shore and at water depths of less than 15 m.

6.1.5 Sediment Quality

Sediment Quality

The physicochemical quality of the sediments in Deception Bay was analyzed in 2006, 2007 and 2011 (Appendix 3) and 2012 (Appendix 4). The sediments of nine stations were analyzed respectively in 2006, 2007 and 2011, and 32 other stations were analyzed in 2012 (Map 5.1).

In 2012, the sampling campaign was conducted by the Stantec team between July 18 and 26, 2012 from a barge-mounted drilling rig. The core holes recovered samples at different depths for the same station (n = 123). To ensure quality control, many duplicates were collected to assess intrastation variability, according to the EC Guidelines (2007), i.e. 10% of the total number of stations.

Under the supervision of the CRI environment team, the samples were prepared and shipped to the Maxxam Analytics Inc. laboratory, where the granulometric and chemical analyses were performed.

Sediment Analysis

The quality of the sediments was analyzed according to the *Canadian Sediment Quality Guidelines for the Protection of Aquatic Life* (CCME 1999, revised in 2001) and the *Critères pour l'évaluation de la qualité des sédiments au Québec* (Québec sediment quality assessment criteria), as specified in the EC and MDDEP guide (2007).

From these two references, it is possible to define three chemical substance concentration ranges (Figure 6.14):

- the lowest concentrations range, when the concentration does not exceed the threshold of the Interim Sediment Quality Guideline (ISQG), equivalent to the threshold effect level (TEL). In this range, harmful biological effects on organisms are rarely observed;
- the possible effects range, located between the ISQG and the probable effect level (PEL). In this range, the occasional effect level (OEL) may be exceeded. This criterion represents the threshold beginning at which harmful effects are apprehended for several benthic species;
- the probable effects range, i.e. when the concentration exceeds the PEL. In this range, harmful biological effects on living organisms are frequently observed.

The parameters analyzed were chosen by considering the contaminants most likely to be produced within the context of the project and according to the recommendations of the government agencies. In 2006, 2007 and 2011, no exceedance of criteria was noted for petroleum hydrocarbons, polycyclic aromatic hydrocarbons, PCB congeners, and total organic carbon content. For the year 2012, only metals (Ag, As, Ba, Cd, Co, Cr, Cu, Hg, Mn, Mo, Ni, Pb, Se, Sn, Zn) were analyzed (Appendix 4).

Table 6.16 presents the results of the physicochemical analyses performed on the 2012 samples. Nearly 39% of the analyses rendered undetected values, given their metal concentrations below the detection limit.

The results indicate that 47% and 76% of the samples exceed the ISQG criterion for chromium and copper respectively, for all depths combined (from the surface of the seabed to 15 m into the sediments). Six of the samples exhibit values above the OEL. Copper and chromium are two metals present in the region's geological formations. This region also has major deposits of copper and nickel ore, which is always associated with chromium (Ministère des Ressources naturelles et de la Faune [MRNF]⁵, 2012). The results obtained by the analyses are all under, or very close to, the background levels of the region's soils, i.e. 50 mg/kg for copper and 85 mg/kg for chromium (GENIVAR, 2008a). The six samples showing exceedances of the OEL criterion for chromium and copper were collected at the stations located near the shore, suggesting the terrigenous origin of these sediments. The Deception Bay seabed sediments (shoreline and glaciomarine) thus reflect the lithological composition of the neighbouring bedrock.

⁵ Ministère des Ressources naturelles (MRN) since September 2012.

CCME criteria	Quality criteria		Dredging sediment management *
		Biological effects frequently observed	The probability of measuring harmful biological effects is very high. Release in open water is proscribed. The sediments must be treated or contained safely.
	FEL		
	PEL		
		Biological effects sometimes observed	The probability of measuring harmful biological effects is relatively high, and increases with the concentration. Release in open water cannot be considered a valid option unless the harmlessness of the sediments to the receiving environment is proved by toxicity tests and the deposit does not contribute to the deterioration of the receiving environment.
	OEL		
ISQG	TEL		
		Biological effects rarely observed	The probability of measuring harmful biological effects is relatively low. The sediments may be released in open water or used for other purposes, on condition that the deposit does not contribute to the deterioration of the receiving.
	REL		

	Class 1
	Class 2
	Class 3

REL : rare effect limit, TEL : threshold effect limit, OEL : occasional effect limit, PEL : probable effect limit, FEL : frequent effect limit.

* Dredging muck management : the option chosen for sediment management must correspond to the option with the least environmental impact, while being economically feasible, regardless of the degree of sediment contamination. In the analysis of the options, sediment reclamation in the terrestrial or aquatic environment must be considered.

Figure 6.14 Canadian Sediment Quality Guidelines (CCME, 1999) Québec sediment quality criteria (taken from Environment Canada and MDDEP, 2007).

The zinc concentration at depth stratum 27'4"-29'4" of station BH-109 shows a value (1,100 mg/kg) that exceeds the threshold of the frequent effect level (FEL) of 430 mg/kg. Only one other station shows a zinc concentration exceedance, i.e. station BH-112, where the concentration of 180 mg/kg at stratum 3'-5' exceeds the OEL while its duplicate shows a concentration of 320 mg/kg, indicating an exceedance of the PEL. These values are very point-source and difficult to explain. First of all, zinc is not recognized as being associated with one geological unit in particular, nor as a known component of a product or a process resulting from on-shore human activities. Moreover, these exceedances of criteria are observed in strata as deep as 10 m in the sediments. However, two hypotheses can be stated to explain such levels.

First of all, the two stations are located in the zone that suffered a rotational landslide in summer 2010 (Map 5.2). At this location, the sediments were deeply disturbed. It is possible that zinc contamination, highly localized on the surface, was disturbed and then buried more than 10 m deep. Rotational landslides are recognized for displacing masses of sediments without necessarily destructuring them.

On the other hand, the hypothesis of contamination of the samples during laboratory analyses is also possible. However, no conclusion can be made, because no sample was retained for cross-checking.

In light of the above results, the physicochemical quality of the sediments turns out not to have a limiting impact on aquatic life. For the three years of monitoring, only the copper and chromium concentrations exceed the sediment quality criteria adopted, and these exceedances are explained by natural background levels in the environment studied. These results also agree with those obtained during the 2004 and 2005 inventories (Roche, 2005; 2006). For all the samples collected during these two years, the chromium and copper concentrations exceeded the threshold for protection of aquatic life.

Since it is proposed to manage the dredged sediments in a terrestrial environment, the criteria of the Soil Protection and Contaminated Sites Rehabilitation Policy (MDDEP, 1998) were consulted (Table 6.16). In the study zone, the levels in force for Superior and Rae Provinces are applicable.

As indicated in Table 6.16, the majority of the exceedances fall between ranges A and B. Thus, these metal contamination levels are not a problem for the land dedicated to sediment management, given its industrial vocation.

Parameters	Units	Detection limit	Station number									Marine sediments quality criteria					MDDEP Policy		
			BH-114	BH-114	BH-114	BH-114 DUP	BH-106	BH-106	BH-106 DUP	BH-106A	BH-106A	IRSQ ¹	COE ²	CPE ³	CFE ⁴	DLR ⁵	A ⁶	B	C
			4'-6'	8'-10'	17'10"-20'6"	8'-10'	6'-8'	12'3"-14'3"	12'3"-14'3"	25'8"-27'8"	31'3"-33'3"								
Metals																			
Mercury (Hg)	mg/kg	0,01	<0,05	<0,05	<0,05	<0,05	<0,05	<0,05	<0,05	<0,05	<0,05	0,13	0,29	0,7	1,4	0,05	0,3	2	10
Silver (Ag)			<2	<2	<2	<2	<2	<2	<2	<2	<2	-	-	-	-	2,0	0,5	20	40
Arsenic (As)	mg/kg	0,5	5	5	4	4	5	4	4	4	<2	7,24	19	41,6	150	0,5	5	30	50
Barium (Ba)			70	70	69	65	80	73	63	75	40	-	-	-	-	5,0	200	500	2000
Cadmium (Cd)	mg/kg	0,05	<0,2	<0,2	<0,2	<0,2	<0,2	<0,2	<0,2	<0,2	<0,2	0,7	2,1	4,2	7,2	2,0	0,9	5	20
Cobalt (Co)			15	14	11	12	8	13	11	11	8	-	-	-	-	2,0	20	50	300
Chromium (Cr)	mg/kg	2	87	81	59	64	51	72	64	48	33	52,3	96	160	290	2,0	85	250	800
Copper (Cu)	mg/kg	1	33	31	23	25	16	27	25	33	29	18,7	42	108	230	1,0	50	100	500
Tin (Sn)			<5	<5	<5	<5	<5	<5	<5	<5	<5	-	-	-	-	5,0	5	50	300
Manganese (Mn)			450	450	400	390	210	450	330	290	180	-	-	-	-	2,0	1000	1000	2200
Molybdenum (Mo)			<2	<2	<2	<2	<2	<2	<2	<2	<2	-	-	-	-	2,0	6	10	40
Nickel (Ni)	mg/kg	2	50	47	32	38	28	41	39	36	25	-	-	-	-	2,0	50	100	500
Lead (Pb)	mg/kg	5	7	7	7	7	<5	8	6	5	<5	30,2	54	112	180	5,0	40	500	1000
Selenium (Se)			<10	<10	<10	<10	<10	<10	<10	<10	<10	-	-	-	-	10,0	3	3	10
Zinc (Zn)	mg/kg	5	59	57	50	53	35	55	48	39	30	124	180	271	430	5,0	120	500	1500

Parameters	Units	Detection limit	Station number								Marine sediments quality criteria					MDDEP Policy			
			BH-115	BH-115	BH-115	BH-115 DUP	BH-116	BH-116	BH-116	BH-116 DUP	IRSQ ¹	COE ²	CPE ³	CFE ⁴	DLR ⁵	A ⁶	B	C	
			7'9"-9'9"	15'-17'	24'8"-26'8"	7'9"-9'9"	4'-7'8"	12'9"-14'9"	22'2"-24'2"	4'-7'8"									
Metals																			
Mercury (Hg)	mg/kg	0,01	<0,05	<0,05	<0,05	<0,05	<0,05	<0,05	<0,05	<0,05	<0,05	0,13	0,29	0,7	1,4	0,05	0,3	2	10
Silver (Ag)			<2	<2	<2	<2	<2	<2	<2	<2	<2	-	-	-	-	2,0	0,5	20	40
Arsenic (As)	mg/kg	0,5	5	5	2	6	5	5	3	5	5	7,24	19	41,6	150	0,5	5	30	50
Barium (Ba)			66	76	69	63	65	73	79	50	50	-	-	-	-	5,0	200	500	2000
Cadmium (Cd)	mg/kg	0,05	<0,2	<0,2	<0,2	<0,2	<0,2	<0,2	<0,2	<0,2	<0,2	0,7	2,1	4,2	7,2	2,0	0,9	5	20
Cobalt (Co)			14	15	10	15	8	15	11	8	8	-	-	-	-	2,0	20	50	300
Chromium (Cr)	mg/kg	2	80	90	44	79	49	86	49	46	46	52,3	96	160	290	2,0	85	250	800
Copper (Cu)	mg/kg	1	30	34	27	33	15	32	28	15	15	18,7	42	108	230	1,0	50	100	500
Tin (Sn)			<5	<5	<5	<5	<5	<5	<5	<5	<5	-	-	-	-	5,0	5	50	300
Manganese (Mn)			450	450	280	440	210	440	300	200	200	-	-	-	-	2,0	1000	1000	2200
Molybdenum (Mo)			<2	<2	<2	<2	<2	<2	<2	<2	<2	-	-	-	-	2,0	6	10	40
Nickel (Ni)	mg/kg	2	45	52	34	49	28	50	36	28	28	-	-	-	-	2,0	50	100	500
Lead (Pb)	mg/kg	5	7	7	<5	8	<5	7	<5	<5	<5	30,2	54	112	180	5,0	40	500	1000
Selenium (Se)			<10	<10	<10	<10	<10	<10	<10	<10	<10	-	-	-	-	10,0	3	3	10
Zinc (Zn)	mg/kg	5	57	59	36	63	33	57	41	34	34	124	180	271	430	5,0	120	500	1500

- (1) IRSQ : Interim recommendation for sediment quality
- (2) COE : concentration of occasional effect
- (3) CPE : concentration of probable effect
- (4) CFE : concentration of frequent effect
- (5) DLR : detection limit reported by the laboratory analysis

Parameters	Units	Detection limit	Station number								Marine sediments quality criteria					MDDEP Policy		
			BH-113	BH-113	BH-113	BH-113 DUP	BH-102	BH-102	BH-102	BH-102 DUP	IRSQ ¹	COE ²	CPE ³	CFE ⁴	DLR ⁵	A ⁶	B	C
			2'-4'	16'3"-18'3"	24'9"-26'9"	2'-4'	0'-2'	9'-11'	15'7"-19'7"	9'-11'								
Metals																		
Mercury (Hg)	mg/kg	0,01	<0,05	<0,05	<0,05	<0,05	<0,05	<0,05	<0,05	<0,05	0,13	0,29	0,7	1,4	0,05	0,3	2	10
Silver (Ag)			<2	<2	<2	<2	<2	<2	<2	<2	-	-	-	-	2,0	0,5	20	40
Arsenic (As)	mg/kg	0,5	5	4	3	(4)	(6)	5	5	4	7,24	19	41,6	150	0,5	5	30	50
Barium (Ba)			64	61	62	63	65	64	66	66	-	-	-	-	5,0	200	500	2000
Cadmium (Cd)	mg/kg	0,05	<0,2	<0,2	<0,2	<0,2	<0,2	<0,2	<0,2	<0,2	0,7	2,1	4,2	7,2	2,0	0,9	5	20
Cobalt (Co)			13	11	10	14	14	14	15	14	-	-	-	-	2,0	20	50	300
Chromium (Cr)	mg/kg	2	(71)	(59)	45	73	80	(77)	80	76	52,3	96	160	290	2,0	85	250	800
Copper (Cu)	mg/kg	1	25	26	28	29	30	29	30	30	18,7	42	108	230	1,0	50	100	500
Tin (Sn)			<5	<5	<5	<5	<5	<5	<5	<5	-	-	-	-	5,0	5	50	300
Manganese (Mn)			390	350	270	420	400	430	450	430	-	-	-	-	2,0	1000	1000	2200
Molybdenum (Mo)			<2	<2	<2	<2	<2	<2	<2	<2	-	-	-	-	2,0	6	10	40
Nickel (Ni)	mg/kg	2	40	(35)	35	44	45	43	46	45	-	-	-	-	2,0	50	100	500
Lead (Pb)	mg/kg	5	6	7	<5	7	7	7	7	7	30,2	54	112	180	5,0	40	500	1000
Selenium (Se)			<10	<10	<10	<10	<10	<10	<10	<10	-	-	-	-	10,0	3	3	10
Zinc (Zn)	mg/kg	5	51	46	36	58	56	56	58	60	124	180	271	430	5,0	120	500	1500

Parameters	Units	Detection limit	Station number									Marine sediments quality criteria					MDDEP Policy		
			BH-104	BH-104	BH-104	BH-104	BH-104 DUP	BH-419	BH-419	BH-419	BH-419 DUP	IRSQ ¹	COE ²	CPE ³	CFE ⁴	DLR ⁵	A ⁶	B	C
			0'-2'	2'-3'9"	17'10"-20'	30'10"-32'10"	17'10"-20'	7'3"-9'3"	11'9"-13'9"	24'2"-26'2"	24'2"-26'2"								
Metals																			
Mercury (Hg)	mg/kg	0,01	<0,05	<0,05	<0,05	<0,05	<0,05	<0,05	<0,05	<0,05	0,13	0,29	0,7	1,4	0,05	0,3	2	10	
Silver (Ag)			<2	<2	<2	<2	<2	<2	<2	<2	-	-	-	-	2,0	0,5	20	40	
Arsenic (As)	mg/kg	0,5	2	2	4	3	4	(6)	2	5	7,24	19	41,6	150	0,5	5	30	50	
Barium (Ba)			26	32	84	51	77	17	21	46	-	-	-	-	5,0	200	500	2000	
Cadmium (Cd)	mg/kg	0,05	<0,2	<0,2	<0,2	<0,2	<0,2	<0,2	<0,2	<0,2	0,7	2,1	4,2	7,2	2,0	0,9	5	20	
Cobalt (Co)			5	5	14	9	14	5	6	9	-	-	-	-	2,0	20	50	300	
Chromium (Cr)	mg/kg	2	(31)	33	78	36	80	35	33	52	52,3	96	160	290	2,0	85	250	800	
Copper (Cu)	mg/kg	1	10	8	30	23	34	11	18	19	18,7	42	108	230	1,0	50	100	500	
Tin (Sn)			<5	<5	<5	<5	<5	<5	<5	<5	-	-	-	-	5,0	5	50	300	
Manganese (Mn)			120	130	430	220	440	130	130	240	420	-	-	-	2,0	1000	1000	2200	
Molybdenum (Mo)			<2	<2	<2	<2	<2	<2	(4)	<2	<2	-	-	-	2,0	6	10	40	
Nickel (Ni)	mg/kg	2	21	20	45	31	50	21	20	30	45	-	-	-	2,0	50	100	500	
Lead (Pb)	mg/kg	5	<5	<5	7	<5	7	<5	<5	<5	30,2	54	112	180	5,0	40	500	1000	
Selenium (Se)			<10	<10	<10	<10	<10	<10	<10	<10	-	-	-	-	10,0	3	3	10	
Zinc (Zn)	mg/kg	5	18	21	58	29	60	19	22	36	124	180	271	430	5,0	120	500	1500	

Parameters	Units	Detection limit	Station number								Marine sediments quality criteria					MDDEP Policy		
			BH-105	BH-105	BH-105	BH-105 DUP	BH-424	BH-424	BH-424	BH-424 DUP	IRSQ ¹	COE ²	CPE ³	CFE ⁴	DLR ⁵	A ⁶	B	C
			8'-10'6"	19'7"-24'7"	35'2"-37'2"	19'7"-24'7"	2'-4'	6'2"-8'2"	14'8"-16'8"	2'-4'								
Metals																		
Mercury (Hg)	mg/kg	0,01	<0,05	<0,05	<0,05	<0,05	<0,05	<0,05	<0,05	<0,05	0,13	0,29	0,7	1,4	0,05	0,3	2	10
Silver (Ag)			<2	<2	<2	<2	<2	<2	<2	<2	-	-	-	-	2,0	0,5	20	40
Arsenic (As)	mg/kg	0,5	(6)	5	2	(3)	(4)	5	3	4	7,24	19	41,6	150	0,5	5	30	50
Barium (Ba)			91	80	62	59	69	77	59	65	-	-	-	-	5,0	200	500	2000
Cadmium (Cd)	mg/kg	0,05	<0,2	<0,2	<0,2	<0,2	<0,2	<0,2	<0,2	<0,2	0,7	2,1	4,2	7,2	2,0	0,9	5	20
Cobalt (Co)			19	16	9	9	12	15	8	12	-	-	-	-	2,0	20	50	300
Chromium (Cr)	mg/kg	2	(110)	(91)	39	45	65	(81)	42	63	52,3	96	160	290	2,0	85	250	800
Copper (Cu)	mg/kg	1	47	37	23	19	26	39	18	27	18,7	42	108	230	1,0	50	100	500
Tin (Sn)			<5	<5	<5	<5	<5	<5	<5	<5	-	-	-	-	5,0	5	50	300
Manganese (Mn)			500	460	250	350	400	420	310	380	-	-	-	-	2,0	1000	1000	2200
Molybdenum (Mo)			<2	<2	<2	<2	<2	<2	<2	<2	-	-	-	-	2,0	6	10	40
Nickel (Ni)	mg/kg	2	(65)	(54)	30	26	36	49	25	38	-	-	-	-	2,0	50	100	500
Lead (Pb)	mg/kg	5	7	7	<5	7	7	7	6	7	30,2	54	112	180	5,0	40	500	1000
Selenium (Se)			<10	<10	<10	<10	<10	<10	<10	<10	-	-	-	-	10,0	3	3	10
Zinc (Zn)	mg/kg	5	72	62	35	48	52	58	40	53	124	180	271	430	5,0	120	500	1500

Parameters	Units	Detection limit	Station number								Marine sediments quality criteria					MDDEP Policy		
			BH-417	BH-417	BH-417	BH-417 DUP	BH-416	BH-416	BH-416	BH-416 DUP	IRSQ ¹	COE ²	CPE ³	CFE ⁴	DLR ⁵	A ⁶	B	C
			2'-4'	13'6"-15'6"	28'7"-30'7"	2'-4'	2'-3'1"	14'-16'3"	24'8"-26'8"	24'8"-26'8"								
Metals																		
Mercury (Hg)	mg/kg	0,01	<0,05	<0,05	<0,05	<0,05	<0,05	<0,05	<0,05	<0,05	0,13	0,29	0,7	1,4	0,05	0,3	2	10
Silver (Ag)			<2	<2	<2	<2	<2	<2	<2	<2	-	-	-	-	2,0	0,5	20	40
Arsenic (As)	mg/kg	0,5	5	(6)	5	4	4	4	4	5	7,24	19	41,6	150	0,5	5	30	50
Barium (Ba)			53	61	82	48	39	62	66	73	-	-	-	-	5,0	200	500	2000
Cadmium (Cd)	mg/kg	0,05	<0,2	<0,2	<0,2	<0,2	<0,2	<0,2	<0,2	<0,2	0,7	2,1	4,2	7,2	2,0	0,9	5	20
Cobalt (Co)			9	11	16	8	7	14	13	14	-	-	-	-	2,0	20	50	300
Chromium (Cr)	mg/kg	2	56	57	(93)	51	46	79	71	76	52,3	96	160	290	2,0	85	250	800
Copper (Cu)	mg/kg	1	22	24	38	22	21	31	34	33	18,7	42	108	230	1,0	50	100	500
Tin (Sn)			<5	<5	<5	<5	<5	<5	<5	<5	-	-	-	-	5,0	5	50	300
Manganese (Mn)			220	280	460	200	180	400	380	410	-	-	-	-	2,0	1000	1000	2200
Molybdenum (Mo)			2	<2	<2	<2	<2	<2	<2	<2	-	-	-	-	2,0	6	10	40
Nickel (Ni)	mg/kg	2	31	33	(52)	32	29	42	42	47	-	-	-	-	2,0	50	100	500
Lead (Pb)	mg/kg	5	<5	5	8	<5	<5	7	7	7	30,2	54	112	180	5,0	40	500	1000
Selenium (Se)			<10	<10	<10	<10	<10	<10	<10	<10	-	-	-	-	10,0	3	3	10
Zinc (Zn)	mg/kg	5	40	48	63	40	33	58	52	59	124	180	271	430	5,0	120	500	1500

Parameters	Units	Detection limit	Station number								Marine sediments quality criteria					MDDEP Policy		
			BH-103	BH-103	BH-103	BH-103 DUP	BH-423	BH-423	BH-423	BH-423 DUP	IRSQ ¹	COE ²	CPE ³	CFE ⁴	DLR ⁵	A ⁶	B	C
			2'6"-4'6"	19'8"-21'8"	29'6"-31'6"	19'8"-21'8"	2'-4'	11'9"-13'9"	14'3"-16'1"	11'9"-13'9"								
Metals																		
Mercury (Hg)	mg/kg	0,01	<0,05	<0,05	<0,05	<0,05	<0,05	<0,05	<0,05	<0,05	0,13	0,29	0,7	1,4	0,05	0,3	2	10
Silver (Ag)			<2	<2	<2	<2	<2	<2	<2	<2	-	-	-	-	2,0	0,5	20	40
Arsenic (As)	mg/kg	0,5	5	4	3	4	2	4	3	4	7,24	19	41,6	150	0,5	5	30	50
Barium (Ba)			61	65	31	67	20	63	73	69	-	-	-	-	5,0	200	500	2000
Cadmium (Cd)	mg/kg	0,05	<0,2	<0,2	<0,2	<0,2	<0,2	<0,2	<0,2	<0,2	0,7	2,1	4,2	7,2	2,0	0,9	5	20
Cobalt (Co)			14	10	7	12	5	10	11	12	-	-	-	-	2,0	20	50	300
Chromium (Cr)	mg/kg	2	77	53	29	70	31	55	60	66	52,3	96	160	290	2,0	85	250	800
Copper (Cu)	mg/kg	1	32	22	22	30	10	24	39	27	18,7	42	108	230	1,0	50	100	500
Tin (Sn)			<5	<5	<5	<5	<5	<5	<5	<5	-	-	-	-	5,0	5	50	300
Manganese (Mn)			430	370	170	370	120	360	310	380	-	-	-	-	2,0	1000	1000	2200
Molybdenum (Mo)			<2	<2	<2	<2	<2	<2	<2	<2	-	-	-	-	2,0	6	10	40
Nickel (Ni)	mg/kg	2	42	29	24	43	20	31	39	40	-	-	-	-	2,0	50	100	500
Lead (Pb)	mg/kg	5	7	8	<5	6	<5	7	<5	7	30,2	54	112	180	5,0	40	500	1000
Selenium (Se)			<10	<10	<10	<10	<10	<10	<10	<10	-	-	-	-	10,0	3	3	10
Zinc (Zn)	mg/kg	5	59	49	60	53	19	48	44	60	124	180	271	430	5,0	120	500	1500

Parameters	Units	Detection limit	Station number								Marine sediments quality criteria					MDDEP Policy		
			BH-418	BH-418	BH-418	BH-418 DUP	BH-101	BH-101	BH-101	BH-101 DUP	IRSQ ¹	COE ²	CPE ³	CFE ⁴	DLR ⁵	A ⁶	B	C
			2'-4'	20'6"-22'6"	32'3"-34'3"	2'-4'	9'2"-11'2"	28'10"-30'10"	46'11"-48'3"	28'10"-30'10"								
Metals																		
Mercury (Hg)	mg/kg	0,01	<0,05	<0,05	<0,05	<0,05	<0,05	<0,05	<0,05	<0,05	0,13	0,29	0,7	1,4	0,05	0,3	2	10
Silver (Ag)			<2	<2	<2	<2	<2	<2	<2	<2	-	-	-	-	2,0	0,5	20	40
Arsenic (As)	mg/kg	0,5	3	3	4	5	5	3	2	4	7,24	19	41,6	150	0,5	5	30	50
Barium (Ba)			36	64	88	44	58	57	54	62	-	-	-	-	5,0	200	500	2000
Cadmium (Cd)	mg/kg	0,05	<0,2	<0,2	<0,2	<0,2	<0,2	<0,2	<0,2	<0,2	0,7	2,1	4,2	7,2	2,0	0,9	5	20
Cobalt (Co)			7	9	15	8	11	9	7	9	-	-	-	-	2,0	20	50	300
Chromium (Cr)	mg/kg	2	45	47	82	48	64	41	29	45	52,3	96	160	290	2,0	85	250	800
Copper (Cu)	mg/kg	1	19	17	37	20	22	18	24	18	18,7	42	108	230	1,0	50	100	500
Tin (Sn)			<5	<5	<5	<5	<5	<5	<5	<5	-	-	-	-	5,0	5	50	300
Manganese (Mn)			170	380	430	190	330	330	180	360	-	-	-	-	2,0	1000	1000	2200
Molybdenum (Mo)			<2	<2	<2	<2	<2	<2	<2	<2	-	-	-	-	2,0	6	10	40
Nickel (Ni)	mg/kg	2	28	26	47	29	36	23	23	26	-	-	-	-	2,0	50	100	500
Lead (Pb)	mg/kg	5	<5	7	7	<5	5	7	<5	7	30,2	54	112	180	5,0	40	500	1000
Selenium (Se)			<10	<10	<10	<10	<10	<10	<10	<10	-	-	-	-	10,0	3	3	10
Zinc (Zn)	mg/kg	5	31	47	60	36	46	42	38	47	124	180	271	430	5,0	120	500	1500

Parameters	Units	Detection limit	Station number							Marine sediments quality criteria					MDDEP Policy		
			BH-420	BH-420	BH-420	BH-108	BH-108	BH-108	BH-108 DUP	IRSQ ¹	COE ²	CPE ³	CFE ⁴	DLR ⁵	A ⁶	B	C
			2'-4'	9'2"-11'2"	28'5"-30'5"	4'-7'10"	7'10"-9'10"	15'2"-17'2"	7'10"-9'10"								
Metals																	
Mercury (Hg)	mg/kg	0,01	<0,05	<0,05	<0,05	<0,05	<0,05	<0,05	<0,05	0,13	0,29	0,7	1,4	0,05	0,3	2	10
Silver (Ag)			<2	<2	<2	<2	<2	<2	<2	-	-	-	-	2,0	0,5	20	40
Arsenic (As)	mg/kg	0,5	3	2	3	4	4	2	4	7,24	19	41,6	150	0,5	5	30	50
Barium (Ba)			30	15	55	65	68	44	68	-	-	-	-	5,0	200	500	2000
Cadmium (Cd)	mg/kg	0,05	<0,2	<0,2	<0,2	<0,2	<0,2	<0,2	<0,2	0,7	2,1	4,2	7,2	2,0	0,9	5	20
Cobalt (Co)			6	5	10	12	12	8	11	-	-	-	-	2,0	20	50	300
Chromium (Cr)	mg/kg	2	38	32	52	65	66	34	63	52,3	96	160	290	2,0	85	250	800
Copper (Cu)	mg/kg	1	16	9	25	27	28	19	27	18,7	42	108	230	1,0	50	100	500
Tin (Sn)			<5	<5	<5	<5	<5	<5	<5	-	-	-	-	5,0	5	50	300
Manganese (Mn)			150	130	330	360	360	210	370	-	-	-	-	2,0	1000	1000	2200
Molybdenum (Mo)			<2	<2	<2	<2	<2	<2	<2	-	-	-	-	2,0	6	10	40
Nickel (Ni)	mg/kg	2	25	21	32	39	38	31	39	-	-	-	-	2,0	50	100	500
Lead (Pb)	mg/kg	5	<5	<5	6	6	6	<5	6	30,2	54	112	180	5,0	40	500	1000
Selenium (Se)			<10	<10	<10	<10	1	<1	<10	-	-	-	-	10,0	3	3	10
Zinc (Zn)	mg/kg	5	26	19	47	50	55	34	53	124	180	271	430	5,0	120	500	1500

Parameters	Units	Detection limit	Station number							Marine sediments quality criteria					MDDEP Policy		
			BH-109	BH-109	BH-109	BH-109 DUP	BH-111	BH-111	BH-111	BH-111 DUP	IRSQ ¹	COE ²	CPE ³	CFE ⁴	DLR ⁵	A ⁶	B
			2'1"-4'1"	7'6"-9'6"	27'4"-29'4"	7'6"-9'6"	2'-4'	8,4"-10'4"	15'6"-17'6"	8'4"-10'4"							
Metals																	
Mercury (Hg)	mg/kg	0,01	<0,05	<0,05	<0,05	<0,05	<0,05	<0,05	<0,05	0,13	0,29	0,7	1,4	0,05	0,3	2	10
Silver (Ag)			<2	<2	<2	<2	<2	<2	<2	-	-	-	-	2,0	0,5	20	40
Arsenic (As)	mg/kg	0,5	2	4	2	5	2	5	2	7,24	19	41,6	150	0,5	5	30	50
Barium (Ba)			42	73	39	79	22	70	65	-	-	-	-	5,0	200	500	2000
Cadmium (Cd)	mg/kg	0,05	<0,2	<0,2	<0,2	<0,2	<0,2	<0,2	<0,2	0,7	2,1	4,2	7,2	2,0	0,9	5	20
Cobalt (Co)			6	15	6	16	5	14	9	-	-	-	-	2,0	20	50	300
Chromium (Cr)	mg/kg	2	40	84	28	93	30	76	40	52,3	96	160	290	2,0	85	250	800
Copper (Cu)	mg/kg	1	13	40	24	40	10	32	27	18,7	42	108	230	1,0	50	100	500
Tin (Sn)			<5	<5	<5	<5	<5	<5	<5	-	-	-	-	5,0	5	50	300
Manganese (Mn)			150	390	130	440	110	400	250	-	-	-	-	2,0	1000	1000	2200
Molybdenum (Mo)			<2	<2	<2	<2	<2	<2	<2	-	-	-	-	2,0	6	10	40
Nickel (Ni)	mg/kg	2	23	54	19	58	18	44	30	-	-	-	-	2,0	50	100	500
Lead (Pb)	mg/kg	5	<5	6	6	6	<5	7	<5	30,2	54	112	180	5,0	40	500	1000
Selenium (Se)			<1	1	<1	<10	<1	1	<10	-	-	-	-	10,0	3	3	10
Zinc (Zn)	mg/kg	5	29	57	1100	68	20	56	34	124	180	271	430	5,0	120	500	1500

Parameters	Units	Detection limit	Station number								Marine sediments quality criteria					MDDEP Policy		
			BH-415	BH-415	BH-415	BH-415 DUP	BH-110	BH-110	BH-110	BH-110	BH-110 DUP	IRSQ ¹	COE ²	CPE ³	CFE ⁴	DLR ⁵	A ⁶	B
			0'-1"	8'6"-10'5"	19'7"-21'7"	8'6"-10'5"	6'8"-8'9"	8,9"-10'9"	15'-17"	8'9"-10'9"								
Metals																		
Mercury (Hg)	mg/kg	0,01	<0,05	<0,05	<0,05	<0,05	<0,05	<0,05	<0,05	<0,05	0,13	0,29	0,7	1,4	0,05	0,3	2	10
Silver (Ag)			<2	<2	<2	<2	<2	<2	<2	<2	-	-	-	-	2,0	0,5	20	40
Arsenic (As)	mg/kg	0,5	3	5	(6)	4	4	3	2	3	7,24	19	41,6	150	0,5	5	30	50
Barium (Ba)			41	54	83	47	56	61	59	66	-	-	-	-	5,0	200	500	2000
Cadmium (Cd)	mg/kg	0,05	<0,2	<0,2	<0,2	<0,2	<0,2	<0,2	<0,2	<0,2	0,7	2,1	4,2	7,2	2,0	0,9	5	20
Cobalt (Co)			8	8	18	7	8	9	9	10	-	-	-	-	2,0	20	50	300
Chromium (Cr)	mg/kg	2	48	50	(110)	41	42	43	39	45	52,3	96	160	290	2,0	85	250	800
Copper (Cu)	mg/kg	1	20	17	41	14	16	22	25	29	18,7	42	108	230	1,0	50	100	500
Tin (Sn)			<5	<5	<5	<5	<5	<5	<5	<5	-	-	-	-	5,0	5	50	300
Manganese (Mn)			190	200	500	170	320	300	240	280	-	-	-	-	2,0	1000	1000	2200
Molybdenum (Mo)			<2	<2	<2	<2	<2	<2	<2	<2	-	-	-	-	2,0	6	10	40
Nickel (Ni)	mg/kg	2	29	27	(62)	25	23	26	30	35	-	-	-	-	2,0	50	100	500
Lead (Pb)	mg/kg	5	<5	<5	7	<5	6	5	<5	<5	30,2	54	112	180	5,0	40	500	1000
Selenium (Se)			<1	1	1	<10	1	1	<1	<10	-	-	-	-	10,0	3	3	10
Zinc (Zn)	mg/kg	5	36	36	69	29	40	40	35	48	124	180	271	430	5,0	120	500	1500

Parameters	Units	Detection limit	Station number								Marine sediments quality criteria					MDDEP Policy		
			BH-412	BH-412	BH-412 DUP	BH-414	BH-414	BH-414	BH-414	BH-414	BH-414 DUP	IRSQ ¹	COE ²	CPE ³	CFE ⁴	DLR ⁵	A ⁶	B
			0'-2'9"	4'9"-6'9"	4'9"-6'9"	0'-2'	7'4"-9'4"	12'2"-14'2"	32'9"-34'9"	7'4"-9'4"								
Metals																		
Mercury (Hg)	mg/kg	0,01	<0,05	<0,05	<0,05	<0,05	<0,05	<0,05	<0,05	<0,05	0,13	0,29	0,7	1,4	0,05	0,3	2	10
Silver (Ag)			<2	<2	<2	<2	<2	<2	<2	<2	-	-	-	-	2,0	0,5	20	40
Arsenic (As)	mg/kg	0,5	4	4	4	3	3	4	4	4	7,24	19	41,6	150	0,5	5	30	50
Barium (Ba)			46	61	71	39	30	50	66	34	-	-	-	-	5,0	200	500	2000
Cadmium (Cd)	mg/kg	0,05	<0,2	<0,2	<0,2	<0,2	<0,2	<0,2	<0,2	<0,2	0,7	2,1	4,2	7,2	2,0	0,9	5	20
Cobalt (Co)			7	8	9	8	6	8	10	7	-	-	-	-	2,0	20	50	300
Chromium (Cr)	mg/kg	2	44	47	48	48	36	51	51	48	52,3	96	160	290	2,0	85	250	800
Copper (Cu)	mg/kg	1	16	17	30	22	13	20	25	16	18,7	42	108	230	1,0	50	100	500
Tin (Sn)			<5	<5	<5	<5	<5	<5	<5	<5	-	-	-	-	5,0	5	50	300
Manganese (Mn)			190	200	210	190	140	210	300	170	-	-	-	-	2,0	1000	1000	2200
Molybdenum (Mo)			<2	<2	<2	(3)	<2	(3)	<2	2	-	-	-	-	2,0	6	10	40
Nickel (Ni)	mg/kg	2	26	26	29	30	21	29	33	29	-	-	-	-	2,0	50	100	500
Lead (Pb)	mg/kg	5	<5	<5	<5	<5	<5	<5	5	<5	30,2	54	112	180	5,0	40	500	1000
Selenium (Se)			1	1	<10	<1	<1	1	1	<10	-	-	-	-	10,0	3	3	10
Zinc (Zn)	mg/kg	5	31	33	45	36	24	36	43	31	124	180	271	430	5,0	120	500	1500

Parameters	Units	Detection limit	Station number							Marine sediments quality criteria					MDDEP Policy		
			BH-107	BH-107	BH-107	BH-107 DUP	BH-411	BH-411	BH-411	IRSQ ¹	COE ²	CPE ³	CFE ⁴	DLR ⁵	A ⁶	B	C
			2'5"-4'5"	6'5"-8'5"	14'9"-16'9"	6'5"-8'5"	2'-4'	4'5"-8'	14'9"-17'								
Metals																	
Mercury (Hg)	mg/kg	0,01	<0,05	<0,05	<0,05	<0,05	<0,05	<0,05	<0,05	0,13	0,29	0,7	1,4	0,05	0,3	2	10
Silver (Ag)			<2	<2	<2	<2	<2	<2	<2	-	-	-	-	2,0	0,5	20	40
Arsenic (As)	mg/kg	0,5	4	3	2	3	4	5	4	7,24	19	41,6	150	0,5	5	30	50
Barium (Ba)			65	53	53	65	50	63	67	-	-	-	-	5,0	200	500	2000
Cadmium (Cd)	mg/kg	0,05	<0,2	<0,2	<0,2	<0,2	<0,2	<0,2	<0,2	0,7	2,1	4,2	7,2	2,0	0,9	5	20
Cobalt (Co)			13	9	9	10	8	15	13	-	-	-	-	2,0	20	50	300
Chromium (Cr)	mg/kg	2	71	41	38	45	51	79	72	52,3	96	160	290	2,0	85	250	800
Copper (Cu)	mg/kg	1	32	26	24	32	19	32	30	18,7	42	108	230	1,0	50	100	500
Tin (Sn)			<5	<5	<5	<5	<5	<5	<5	-	-	-	-	5,0	5	50	300
Manganese (Mn)			360	250	240	290	200	440	410	-	-	-	-	2,0	1000	1000	2200
Molybdenum (Mo)			<2	<2	<2	<2	2	<2	<2	-	-	-	-	2,0	6	10	40
Nickel (Ni)	mg/kg	2	42	32	30	36	28	44	43	-	-	-	-	2,0	50	100	500
Lead (Pb)	mg/kg	5	6	<5	<5	7	<5	7	7	30,2	54	112	180	5,0	40	500	1000
Selenium (Se)			1	<1	1	<10	1	1	<10	-	-	-	-	10,0	3	3	10
Zinc (Zn)	mg/kg	5	50	37	32	44	36	58	57	124	180	271	430	5,0	120	500	1500

Parameters	Units	Detection limit	Station number							Marine sediments quality criteria					MDDEP Policy			
			BH-408	BH-408	BH-408	BH-408 DUP	BH-112	BH-112	BH-112	BH-112 DUP	IRSQ ¹	COE ²	CPE ³	CFE ⁴	DLR ⁵	A ⁶	B	C
			2'2"-4'2"	4'2"-6'2"	11'10"-13'10"	4'2"-6'2"	1'-3"	3'-5'	7'6"-9'6"	3'-5'								
Metals																		
Mercury (Hg)	mg/kg	0,01	<0,05	<0,05	<0,05	<0,05	<0,05	<0,05	<0,05	0,13	0,29	0,7	1,4	0,05	0,3	2	10	
Silver (Ag)			<2	<2	<2	<2	<2	<2	<2	-	-	-	-	2,0	0,5	20	40	
Arsenic (As)	mg/kg	0,5	(6)	(6)	2	4	4	4	2	7,24	19	41,6	150	0,5	5	30	50	
Barium (Ba)			62	82	65	79	52	54	28	43	-	-	-	5,0	200	500	2000	
Cadmium (Cd)	mg/kg	0,05	<0,2	<0,2	<0,2	<0,2	<0,2	<0,2	<0,2	0,7	2,1	4,2	7,2	2,0	0,9	5	20	
Cobalt (Co)			7	9	9	8	7	8	6	7	-	-	-	2,0	20	50	300	
Chromium (Cr)	mg/kg	2	46	55	41	48	45	45	25	43	52,3	96	160	2,0	85	250	800	
Copper (Cu)	mg/kg	1	15	20	32	17	15	20	21	17	18,7	42	108	1,0	50	100	500	
Tin (Sn)			<5	<5	<5	<5	<5	<5	<5	300	-	-	-	5,0	5	50	300	
Manganese (Mn)			180	250	240	210	180	260	130	170	-	-	-	2,0	1000	1000	2200	
Molybdenum (Mo)			2	<2	<2	2	2	<2	<2	40	-	-	-	2,0	6	10	40	
Nickel (Ni)	mg/kg	2	26	33	32	29	26	27	24	27	-	-	-	2,0	50	100	500	
Lead (Pb)	mg/kg	5	<5	<5	<5	<5	<5	7	<5	<5	30,2	54	112	180	5,0	40	500	1000
Selenium (Se)			1	<10	<10	<10	<10	<10	<10	10	-	-	-	10,0	3	3	10	
Zinc (Zn)	mg/kg	5	32	40	38	35	32	(180)	31	(320)	124	180	271	430	5,0	120	500	1500

Parameters	Units	Detection limit	Station number								Marine sediments quality criteria					MDDEP Policy		
			BH-117	BH-117	BH-117	BH-117 DUP	BH-413	BH-413	BH-413	BH-413 DUP	IRSQ ¹	COE ²	CPE ³	CFE ⁴	DLR ⁵	A ⁶	B	C
			7'6"-9'6"	15'10"-17'10"	35'5"-39'6"	35'5"-39'6"	2'8"-4'8"	9'11'	16'9"-18'9"									
Metals																		
Mercury (Hg)	mg/kg	0,01	<0,05	<0,05	<0,05	<0,05	<0,05	<0,05	<0,05	<0,05	0,13	0,29	0,7	1,4	0,05	0,3	2	10
Silver (Ag)			<2	<2	<2	<2	<2	<2	<2	<2	-	-	-	-	2,0	0,5	20	40
Arsenic (As)	mg/kg	0,5	5	5	5	5	3	5	5	3	7,24	19	41,6	150	0,5	5	30	50
Barium (Ba)			66	92	79	90	41	56	72	39	-	-	-	-	5,0	200	500	2000
Cadmium (Cd)	mg/kg	0,05	<0,2	<0,2	<0,2	<0,2	<0,2	<0,2	<0,2	<0,2	0,7	2,1	4,2	7,2	2,0	0,9	5	20
Cobalt (Co)			14	18	16	17	7	9	16	7	-	-	-	-	2,0	20	50	300
Chromium (Cr)	mg/kg	2	78	(100)	(88)	(100)	46	57	(90)	47	52,3	96	160	290	2,0	85	250	800
Copper (Cu)	mg/kg	1	31	45	43	44	18	24	37	19	18,7	42	108	230	1,0	50	100	500
Tin (Sn)			<5	<5	<5	<5	<5	<5	<5	<5	-	-	-	-	5,0	5	50	300
Manganese (Mn)			450	480	410	500	180	230	470	190	-	-	-	-	2,0	1000	1000	2200
Molybdenum (Mo)			<2	<2	<2	<2	<2	(3)	<2	<2	-	-	-	-	2,0	6	10	40
Nickel (Ni)	mg/kg	2	46	(63)	(59)	(63)	26	33	(53)	28	-	-	-	-	2,0	50	100	500
Lead (Pb)	mg/kg	5	7	7	6	7	<5	<5	7	<5	30,2	54	112	180	5,0	40	500	1000
Selenium (Se)			<10	<10	<10	<10	1	<10	<10	<10	-	-	-	-	10,0	3	3	10
Zinc (Zn)	mg/kg	5	59	69	58	70	33	41	63	33	124	180	271	430	5,0	120	500	1500

Parameters	Units	Detection limit	Station number			Marine sediments quality criteria					MDDEP Policy						
			BH-410	BH-410	BH-410 DUP	IRSQ ¹	COE ²	CPE ³	CFE ⁴	DLR ⁵	A ⁶	B	C				
			2'-4'	4'1"-6'1"	4'1"-6'1"												
Metals																	
Mercury (Hg)	mg/kg	0,01	<0,05	<0,05	<0,05	0,13	0,29	0,7	1,4	0,05	0,3	2	10				
Silver (Ag)			<2	<2	<2	-	-	-	-	2,0	0,5	20	40				
Arsenic (As)	mg/kg	0,5	4	3	3	7,24	19	41,6	150	0,5	5	30	50				
Barium (Ba)			72	58	56	-	-	-	-	5,0	200	500	2000				
Cadmium (Cd)	mg/kg	0,05	<0,2	<0,2	<0,2	0,7	2,1	4,2	7,2	2,0	0,9	5	20				
Cobalt (Co)			8	9	9	-	-	-	-	2,0	20	50	300				
Chromium (Cr)	mg/kg	2	46	45	45	52,3	96	160	290	2,0	85	250	800				
Copper (Cu)	mg/kg	1	16	18	19	18,7	42	108	230	1,0	50	100	500				
Tin (Sn)			<5	<5	<5	-	-	-	-	5,0	5	50	300				
Manganese (Mn)			190	350	350	-	-	-	-	2,0	1000	1000	2200				
Molybdenum (Mo)			<2	<2	<2	-	-	-	-	2,0	6	10	40				
Nickel (Ni)	mg/kg	2	28	25	27	-	-	-	-	2,0	50	100	500				
Lead (Pb)	mg/kg	5	<5	7	9	30,2	54	112	180	5,0	40	500	1000				
Selenium (Se)			<10	<10	<10	-	-	-	-	10,0	3	3	10				
Zinc (Zn)	mg/kg	5	33	45	45	124	180	271	430	5,0	120	500	1500				

Only the zinc concentration of sample BH-109 (stratum 27'4"-29'4") has a contamination level between ranges B and C. However, this contamination is highly localized and very probably is located in the sediment layer. Moreover, this phenomenon has never been noted in the physicochemical analyses performed since 2006. Only one sample out of a total of about 170 samples analyzed between 2006 and 2012 shows such a concentration and this result is considered unrepresentative of the quality of the site Q1 sediments. Therefore, it is not considered in the interpretation of the results.

6.1.6 Hydrosedimentary Dynamics

In light of the data on all components of the physical environment, it appears that sediment transport is somewhat limited in Deception Bay, especially at sites Q1 and Q2. The shoreline of Deception Bay is relatively narrow and the type of coast is somewhat rocky, or sometimes veiled in sediments. The shoreline widens locally at the outfall of the rivers, where the debris cones accumulate, or form a better developed intertidal zone.

Sediment Inflows in the Coastal System

The sediment inflows in Deception Bay are very limited. The Deception River, despite its size, has a low sediment transport capacity. The coarsest sediments are deposited directly in the river delta, while the finer sediment load is decanted gradually and trapped in the basins more than 80 m deep at the back of Deception Bay. The sediment dynamics of the Bombardier Beach River is similar to those of the Deception River, with the coarsest sediments locally feeding Bombardier Beach.

Slush Flows

The torrents located completely to the northwest of the study zone do not seem, a priori, to transport large quantities of sediments to Deception Bay, based on the modest width of their respective deltas. However, the slush flows and the debris flows coming from them could contribute sporadically to the sediment balance of the Deception Bay shoreline. The debris cones at the valley outfalls are evidence of the large extent of these phenomena.

Finally, shoreline erosion is not an especially worrying process, to the extent that glacio-isostatic uplift is currently occurring at a greater rate than sea level rise. Shoreline erosion thus is not likely to supply sediment to the coastal system.

Moreover, the results of the suspended particulate matter analyses show that the sediment load of the waters flowing into Deception Bay is practically nil, except near the shores during high winds.

Coastal Dynamics

Coastal sediment transport seems to be especially limited. No shoreline form is evidence of a marked process, or a dominant sediment transport direction. Moreover, the current speed measurements do not show the predominance of marked sediment transport episodes. Only suspended transport seems effective, while bedload transport could be sporadic, localized and limited to transport of the sandy silts present at certain locations on top of glaciomarine clays. Finally, the presence of boulders on the stand indicates a certain glacial transport activity.

No other sedimentary facies associated with existing sediment transport has been identified formally in the sediment core samples analyzed. The proximity of glaciomarine clay outcropping at several locations and its omnipresence at sites Q1 and Q2 are evidence that there have been very few sedimentation episodes in recent millennia.

6.1.7 Marine Sound Environment

A characterization of the underwater sound environment of Deception Bay was produced in 2012 (GENIVAR, 2012b). A series of surveys was conducted in the bay to measure the background noise of the sites (reference status) and determine the distances at which the noises generated by port infrastructures construction work could be a source of disturbance for marine mammals. A sector report presenting all the results can be found in Appendix 10.

6.1.7.1 Ambient Noise

During the measuring periods, the average ambient air was mainly affected by anthropogenic activities related to the traffic of small craft and the unloading of an oil tanker (the Havelstern) at the Xstrata Nickel facilities. Although relatively constant, the noise of the oil tanker's compressors and pumps oscillated between 116.99 and 126.81 dB re 1 $\mu\text{Pa}_{\text{rms}}$ (Table 3 and Appendix 3). A relatively high sound pressure was recorded during the passage of an Xstrata Nickel zodiac, for which a value reaching 125.6 dB re 1 $\mu\text{Pa}_{\text{rms}}$ was recorded when it circulated about 1,200 from the measuring instruments. In calm weather and during momentary interruptions of port activities, the ambient noise decreased to 102.15 dB re 1 $\mu\text{Pa}_{\text{rms}}$. Table 6.17 presents the marine sound pressure levels measured and the dominant frequency bands.

Table 6.17 Typical underwater sound pressure levels measured directly in Deception Bay on July 12, 2012.

Main source	Sound pressure levels		Dominant frequency bands
	Maximum* dB re 1 $\mu\text{Pa}_{\text{rms}}$	RMS** dB re 1 $\mu\text{Pa}_{\text{rms}}$	Maximum* dB re 1 $\mu\text{Pa}_{\text{rms}}$
Flat calm	96.45	102.15	(225-275)
Oil tanker unloading	121.73	126.81	(225-275)
Oil tanker unloading and sonar	114.71	116.99	(225-275; 25,000)
Passage of a zodiac	119.44	125.61	(3,000-3,500)

* Maximum instantaneous sound pressure measured

** Effective sound pressure, calculated over a period of 100 ms

The measurements established that the mean ambient sound during a nocturnal tidal cycle was 120.22 ± 0.48 dB re 1 $\mu\text{Pa}_{\text{rms}}$.

6.1.7.2 Sound Attenuation

Table 6.18 presents the sound attenuation values at sites Q1 and Q2 for the reference frequencies of 250 Hz to 16 kHz and at distances of 100 m, 500 m and 1 000 m from the emission point.

Table 6.18 Sound attenuation at sites Q1 and Q2.

Distance from the emission point (m)	Site Q1 dB re 1 $\mu\text{Pa}_{\text{rms}}$	Site Q2 dB re 1 $\mu\text{Pa}_{\text{rms}}$
100	41.6 ± 3.0	39.6 ± 3.7
500	56.5 ± 4.4	53.5 ± 5.2
1,000	62.9 ± 5.0	59.5 ± 5.8

These variations are essentially explained by the relative position of the wharf location scenarios and the configuration of the bay along the different measuring axes. Thus, the fastest attenuation is observed to the northwest, towards the mouth of the bay from the Q1 location scenario, while the weakest is observed perpendicular to the bay, to the northeast, from Q2 location scenario.

6.2 Biological Environment

6.2.1 Marine Environment

6.2.1.1 Aquatic Grass Beds

The inventory of aquatic grass beds conducted by underwater diving allowed identification of seven different taxa, five of which are brown algae belonging to the Phaeophyceae class. Table 6.19 indicates the coverage rates of the species

inventoried in each quadrat (Map 6.4). The underwater photographs are available in Appendix 11. All of this data indicates a higher rate of grass bed coverage for the site Q2 transects than for site Q1. These results are explained, in particular, by the little vegetation found in the quadrats farthest from the shore (5 and 6) for the site Q1 transects, compared to those of site Q2. Little or no vegetation was found in these site Q1 quadrats and the proportion does not exceed 15%. At site Q2, the coverage rates of quadrats 5 and 6 range from 15% to 100%.

The analysis of the data from Table 6.19 and the underwater photographs taken in certain quadrats (Appendix 11) make it possible to see a clear dominance of the Fucaceae in the site Q2 transects, compared to site Q1.

Regarding the laminaria, similar coverage was noted at both sites. At site Q1, the coverage rates range from 1% to 75%, while at site Q2, the values range between 1% and 90%.

6.2.1.2 Benthic Fauna

Epibenthic Fauna

A qualitative inventory of epibenthic fauna was conducted by the divers for each quadrat analyzed for the aquatic grass beds (Map 6.4). Table 6.20 lists the 25 taxa that were identified. The seabed of sites Q1 and Q2 is composed of several sediment types.

Thus, the coarsest sediment, composed of boulders and gravel, explains the presence of sessile organisms using these structures to fasten themselves to them, such as the ascidians and the individuals belonging to the Balanidae class.

Conversely, the presence of sand and silt explains the presence of organisms such as molluscs. In the analysis of the results, the average number of taxa found is higher at site Q2 (13.5) than at site Q1 (5.75).

Endobenthic Fauna

To characterize the endobenthic fauna communities, a taxonomic analysis of the 16 grab samples was performed. Table 6.21 presents the densities of the taxa identified at each station (Map 6.4). The sampling made is possible to collect 72 species at the two sites (Q1 and Q2). The identification of the genus and species for this year provides a much more precise picture compared to the previous field campaigns, for which the taxonomic level identified was the family.

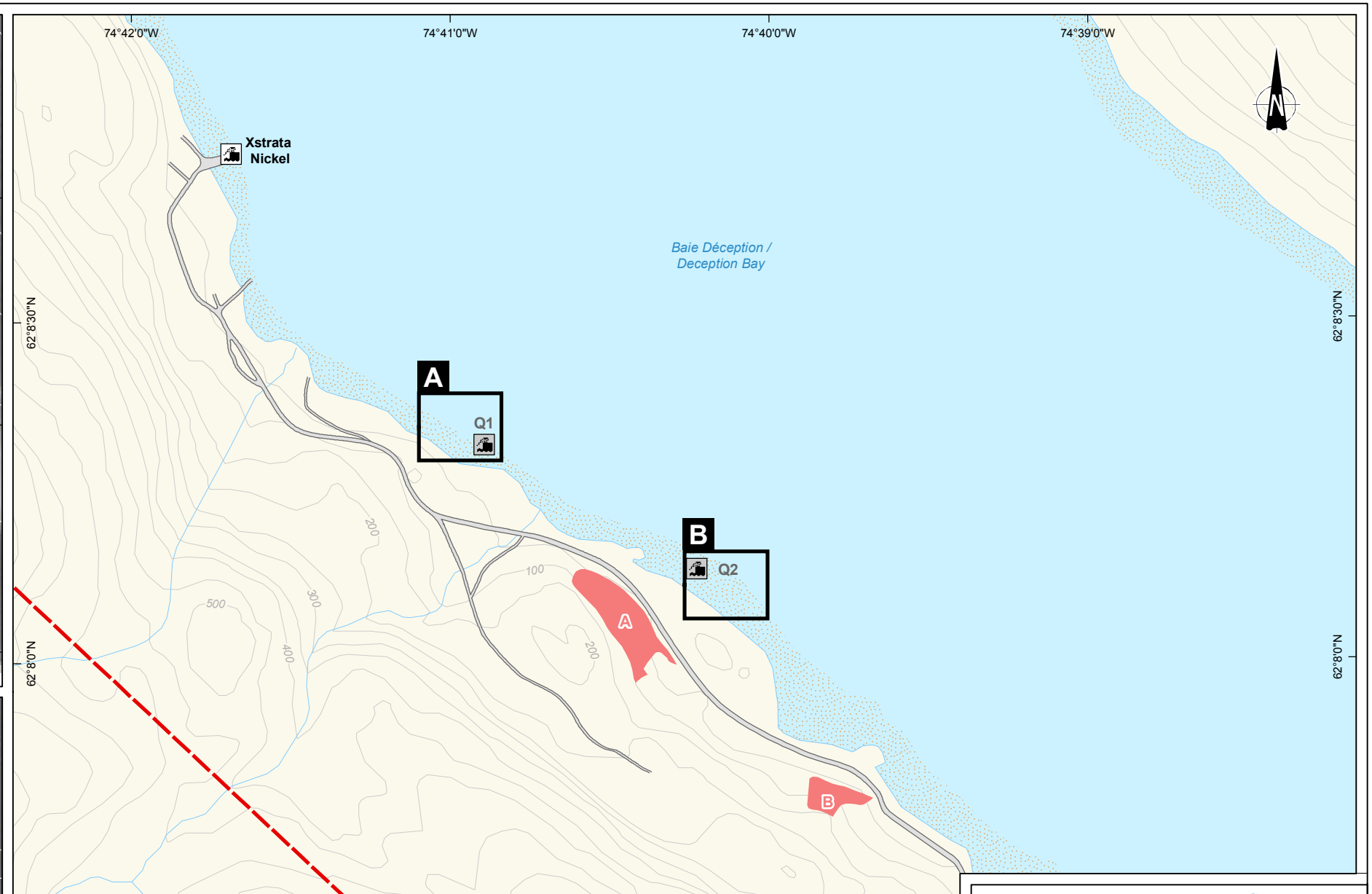
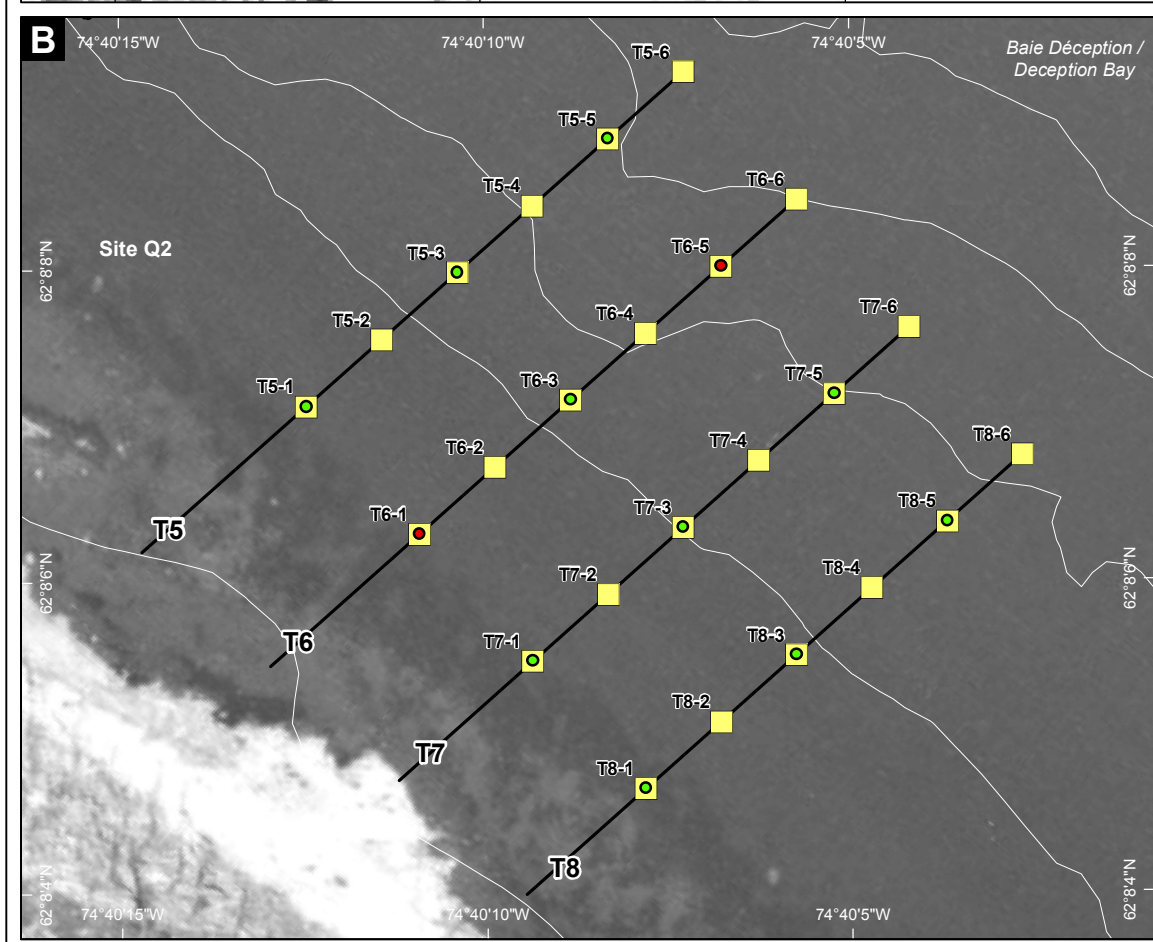
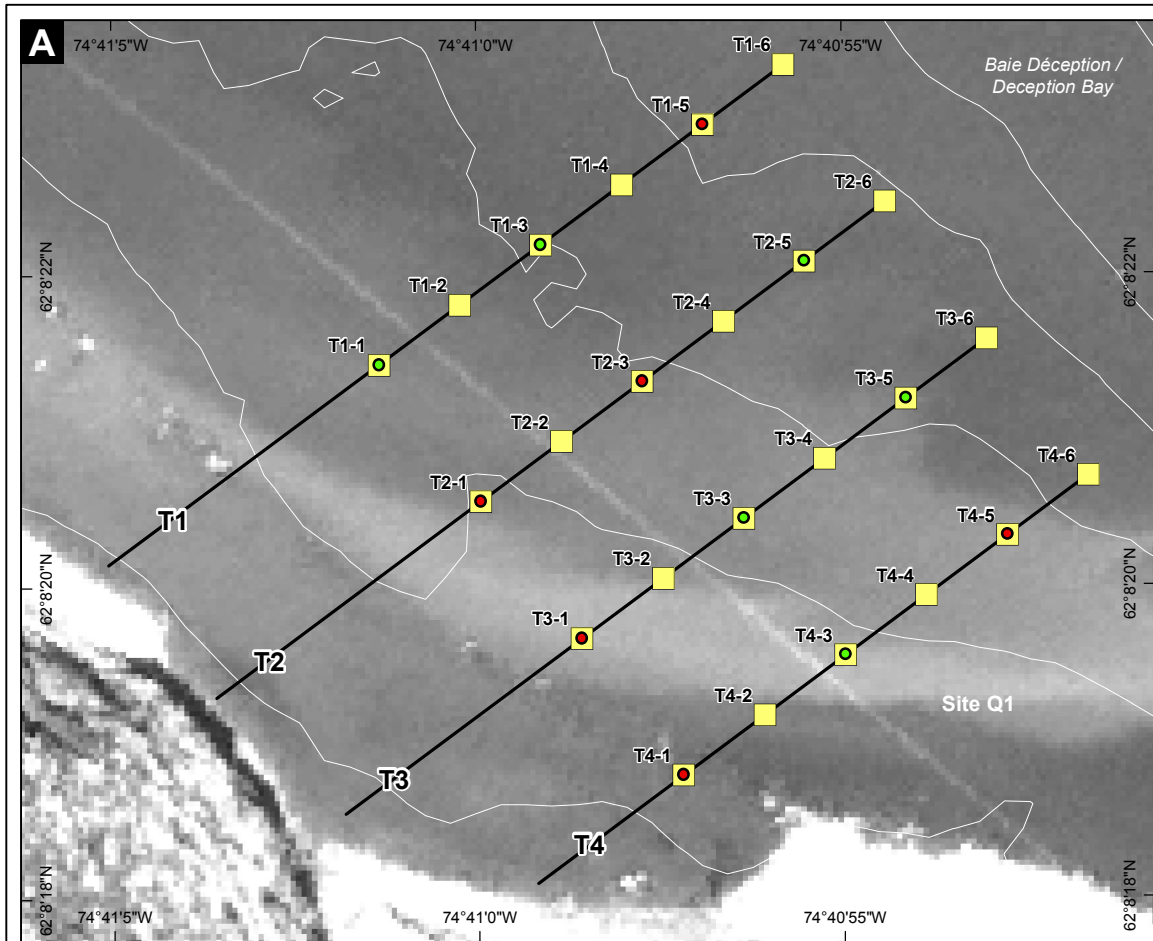

Échantillonnage / Sampling

- Benne complétée / Completed grab sampler
- Benne refusé / Refused grab sampler
- Quadrat quantitatif / Quantitative quadrat
- Transect vidéo / Video transect
- Isobathe / Isobath (m)

Composantes du projet / Project Components

- Infrastructures portuaires projetées (variantes) / Proposed wharf (variants)
- Site de dépôt des sédiments (variantes) / Sediment disposal site (variants)
- Zone d'étude / Study area

Infrastructures existantes / Existing Infrastructure

- Infrastructures portuaires / Wharf
- Route / Road

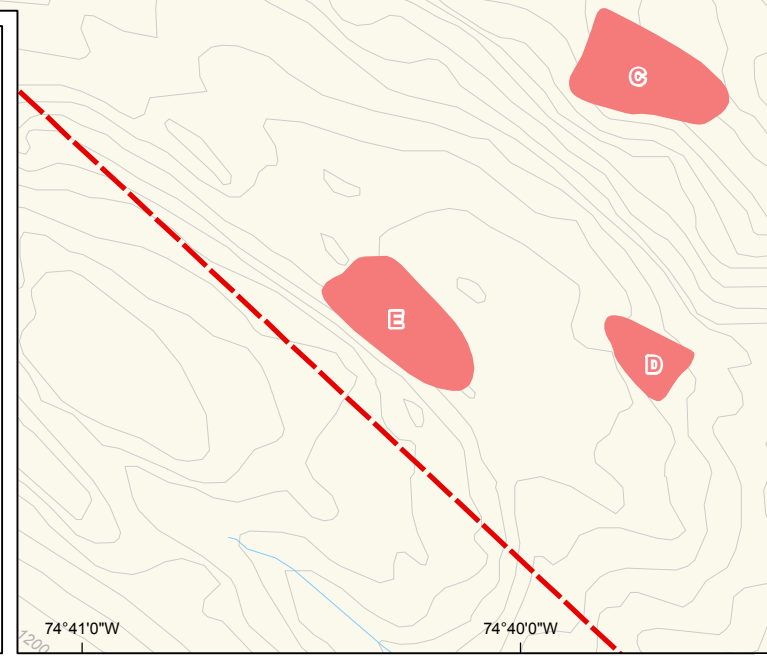

CANADIAN ROYALTIES INC.

Projet Nunavik Nickel / Nunavik Nickel Project
 EIES pour l'aménagement d'infrastructures portuaires et la gestion des sédiments à la baie Déception /
 ESIA for the Deception Bay Wharf and Sediment Management

Carte 6.4 / Map 6.4
Localisation des stations de caractérisation du benthos et des herbiers aquatiques aux sites Q1 et Q2, août 2012 /
Benthos and Aquatic-Grass Bed Characterization Stations Locations for Q1 and Q2 sites, August 2012

0 15 30 45 m
 Projection : UTM, zone 18, NAD83
 Équidistance des courbes / Contour Interval : 50 pieds / feet

Source :
 Base : BNDT, 1 : 50 000, 1976 à 1995**, © Sa Majesté la Reine du Chef du Canada, reproduit avec la permission de RNCan

Inventaires et cartographie / Surveys and mapping : GENIVAR
 Fichier / File : 101_53046_EIES_BD_c6_4_benthos_121120.mxd

Novembre / November 2012
 101-53046-02

Table 6.21 Endobenthic invertebrates densities (no. of organismes/m²) measured at sites Q1 and Q2, August 2012.

Phylum	Class	Order	Family	Genus	Species	Scientific name	Q1						Q2																	
							T1-1	T1-3	T2-5	T3-3	T3-5	T4-3	T5-1	T5-3	T5-5	T6-3	T7-1	T7-3	T7-5	T8-1	T8-3	T8-5								
Arthropoda	Ostracoda	Podocopida	Trachyleberididae	Acanthocythereis	dunelmensis	<i>Acanthocythereis dunelmensis</i>	0	29	0	0	0	0	0	116	290	0	0	0	0	0	0	0	0	0	0	0	0	0	0	0
Mollusca	Gastropoda		Acmaeidae	Acmaea	testudinialis	<i>Testudinalia testudinialis</i>	0	29	0	58	0	0	0	0	0	0	0	0	0	232	0	0	0	0	0	0	0	0	0	
Annelida	Polychaeta	Terebellida	Ampharetidae	Ampharete		<i>Ampharete</i> sp.	0	58	0	116	0	0	0	0	116	0	0	0	58	58	0	0	0	0	0	0	0	0	0	
Annelida	Polychaeta	Terebellida	Ampharetidae				58	0	0	174	29	0	0	0	0	0	0	0	0	0	0	0	0	0	0	0	0	0	0	
Annelida	Polychaeta	Terebellida	Terebellidae	Amphitrite	cirrata	<i>Amphitrite cirrata</i>	0	0	0	0	0	0	0	0	0	0	0	0	0	58	0	0	0	0	0	0	0	0	0	
Arthropoda	Malacostraca	Amphipoda	Uristidae	Anonyx		<i>Anonyx</i> sp.	0	0	0	0	0	0	0	0	0	0	0	0	0	0	0	0	0	0	0	0	0	0	116	
Annelida	Polychaeta		Paraonidae	Aricidea	hartmani	<i>Aricidea c.f. hartmani</i>	0	58	0	58	0	0	0	0	406	116	0	0	0	0	0	0	0	0	0	754	58	0	0	
Annelida	Polychaeta		Paraonidae	Aricidea	nolani	<i>Aricidea nolani</i>	0	0	0	58	0	0	0	464	0	174	0	58	58	0	0	0	0	0	0	0	0	0	0	
Annelida	Polychaeta		Paraonidae	Aricidea		<i>Aricidea</i> sp.	0	87	0	0	0	0	0	116	0	0	0	0	0	0	0	0	0	0	0	0	58	0	0	
Annelida	Polychaeta	Terebellida	Ampharetidae	Asabellides	sibirica	<i>Asabellides sibirica</i>	0	29	0	1 043	0	0	0	116	0	0	0	348	580	0	406	0	0	0	0	0	0	0	0	
Chordata	Ascidiacea						0	0	0	0	0	0	0	0	0	29	29	0	0	0	0	0	0	0	0	0	0	0	0	
Chordata	Ascidiacea	Phlebobranch	Ascidiidae			Ascidiidae spp.	0	0	0	0	0	0	0	0	58	0	0	0	0	0	0	0	0	0	0	0	0	0	0	
Mollusca	Bivalvia	Carditoida	Astartidae	Astarte	elliptica	<i>Astarte elliptica</i> complexe	0	0	0	0	0	0	0	116	290	0	0	0	0	0	0	0	0	0	0	0	0	0	0	
Mollusca	Bivalvia	Carditoida	Astartidae	Astarte	montagui	<i>Astarte montagui</i> complexe	0	0	0	0	0	0	0	0	58	0	0	0	116	0	0	0	0	0	0	0	0	0	0	
Mollusca	Bivalvia	Carditoida	Astartidae	Astarte		<i>Astarte</i> sp.	0	29	0	0	0	0	0	0	0	0	0	0	0	0	0	0	0	0	0	0	0	0	0	
Echinodermat	Asteroidea						0	0	0	0	29	0	0	0	0	0	0	0	0	0	0	0	0	0	0	0	0	0	0	
Annelida	Polychaeta	Phyllodocida	Syllidae				0	0	0	0	0	0	0	0	0	0	0	0	0	58	0	0	0	0	0	0	0	0	0	
Mollusca	Bivalvia	Lucinoida	Thyasiridae	Axinopsida	orbiculata	<i>Axinopsida orbiculata</i>	0	0	29	0	0	0	0	0	0	0	0	0	464	0	0	0	0	0	0	0	0	0	0	
Annelida	Polychaeta	Phyllodocida	Nephtyidae	Bipalponephtys	neotena	<i>Bipalponephtys neotena</i>	58	0	145	116	58	0	0	0	116	0	0	0	0	0	0	0	0	0	0	0	0	0	0	
Mollusca	Bivalvia						1 043	551	0	1 913	87	87	0	348	464	29	0	0	290	0	116	0	0	0	0	0	0	0	0	
Bryozoa							0	0	0	0	0	0	0	0	0	0	0	0	0	0	0	0	0	0	0	0	0	0	29	
Mollusca	Gastropoda	Neogastropod	Buccinidae			Buccinidae spp.	0	0	0	0	0	0	0	0	0	0	0	0	58	0	0	0	0	0	0	0	0	0	0	
Arthropoda	Maxillopoda	Calanoida					0	0	0	0	29	0	0	0	0	0	0	0	0	0	0	0	0	0	0	0	0	0	0	
Bryozoa	Gymnolaemat	Cheilostomatii	Calloporidae	Callopora	lineata	<i>Callopora lineata</i>	0	0	0	0	0	0	0	0	0	0	0	0	29	0	0	0	0	0	0	0	0	0	0	
Cnidaria	Hydrozoa	Leptothecata	Campanulariidae				0	29	0	0	0	0	0	0	0	0	0	0	0	0	0	0	0	0	0	0	0	0	0	
Annelida	Polychaeta		Capitellidae	Capitella	capitata	<i>Capitella capitata</i>	406	319	0	812	0	3 333	29	116	232	377	1 333	58	0	87	116	0	0	0	0	0	0	0	0	
Annelida	Polychaeta		Capitellidae	Capitella		<i>Capitella</i> sp. A	0	493	0	986	0	0	0	0	58	87	0	0	0	0	0	0	0	0	0	0	0	0	0	
Annelida	Polychaeta		Capitellidae	Capitella		<i>Capitellidae</i> spp.A	348	29	0	116	0	0	0	232	0	319	0	174	0	290	58	0	0	0	0	0	0	0	0	
Arthropoda	Malacostraca	Amphipoda	Caprellidae	Caprella		<i>Caprella</i> sp.	0	0	0	0	0	0	0	0	0	0	0	0	0	0	0	0	0	0	0	0	58	0	0	
Mollusca	Bivalvia	Veneroida	Cardiidae			Cardiidae spp.	0	0	0	58	87	0	0	0	0	0	0	0	0	0	0	0	0	0	0	0	0	0	0	
Bryozoa	Gymnolaemat	Cheilostomatii	Celleporidae	Cellepora		<i>Cellepora</i> sp.	0	29	0	29	0	0	0	0	0	0	0	0	0	0	0	0	0	0	0	0	0	0	0	
Bryozoa	Gymnolaemat	Cheilostomatii	Celleporidae			Celleporidae spp.	0	0	29	0	0	0	0	0	0	0	0	0	0	0	0	0	0	0	0	0	0	0	0	
Annelida	Polychaeta	Terebellida	Cirratulidae	Chaetozone		<i>Chaetozone</i> sp.	609	0	58	0	0	0	0	8 116	4 406	4 783	0	0	1 797	0	0	0	0	0	0	696	0	0		
Bryozoa	Gymnolaemat	Cheilostomatida				Cheilostomatida	0	0	0	0	0	0	0	0	29	0	0	0	0	0	0	0	0	0	0	0	0	0	0	
Mollusca	Bivalvia	Veneroida	Cardiidae	Ciliatocardium	ciliatum	<i>Ciliatocardium ciliatum</i>	0	0	58	0	0	0	0	0	58	0	0	0	0	0	0	0	0	0	0	0	0	0	0	
Annelida	Polychaeta	Terebellida	Cirratulidae			Cirratulidae spp.	0	116	0	348	0	0	0	0	0	0	0	290	0	0	0	0	0	0	0	0	0	0	0	
Annelida	Polychaeta	Terebellida	Pectinariidae	Cistenides	hyperborea	<i>Cistenides hyperborea</i>	899	783	58	580	29	145	0	696	58	406	0	812	406	0	406	0	0	0	0	406	58	0	0	
Annelida	Polychaeta		Cossuridae	Cossura		<i>Cossura</i> sp.	0	0	0	0	0	0	0	116	0	0	0	0	58	0	0	0	0	0	0	0	0	0	0	
Mollusca	Bivalvia	Mytiloida	Mytilidae	Crenella	faba	<i>Crenella faba</i>	0	29	0	812	0	174	0	0	0	29	0	0	0	0	0	0	0	0	0	0	0	0	0	
Bryozoa	Stenolaemata	Cyclostomatid	Crisiidae	Crisia		<i>Crisia</i> sp.	0	0	0	0	0	0	0	0	0	0	0	0	29	0	0	0	0	0	0	0	0	0	0	
Arthropoda	Malacostraca	Cumacea					0	0	0	0	29	0	0	0	0	0	0	0	0	0	0	0	0	0	0	0	0	0	0	
Arthropoda	Maxillopoda	Cyclopoida					0	0	0	0	0	0	0	3 130	522	406	0	0	58	0	0	0	0	0	0	0	0	0	0	
Bryozoa	Stenolaemata	Cyclostomata					0	0	0	0	0	0	0	0	29	0	0	0	0	0	0	0	0	0	0	0	0	0	0	
Arthropoda	Ostracoda	Podocopida					841	174	0	232	0	87	0	1 275	1 913	29	0	696	638	0	116	0	0	0	0	0	0	0	0	
Echinodermat	Holothuroidea						29	0	0	0	0	0	0	0	0	0	0	0	0	0	0	0	0	0	0	0	0	0	0	
Arthropoda	Malacostraca	Cumacea	Diastylidae	Diastylis	rathkei	<i>Diastylis rathkei sarsi</i>	0	0	0	0	29	0	0	0	0	0	0	0	0	0	0	0	0	0	0	0	0	0	0	
Annelida	Polychaeta	Phyllodocida	Phyllodocidae	Eteone		<i>Eteone</i> sp.A	2 087	406	0	1 275	0	0	0	1 855	406	783	87	174	406	29	232	58	0	0	0	406	0	0	0	
Annelida	Polychaeta	Sabellida	Sabellidae	Euchone	analis	<i>Euchone analis</i>	174	0	0	464	0	0	0	232	0	58	0	4 754	0	0	406	0	0	0	0	0	0	0	0	
Annelida	Polychaeta	Sabellida	Sabellidae	Euchone	incolor	<i>Euchone incolor</i>	0	0	0	0	0	0	0	232	0	0	0	0	0	0	0	0	0	0	0	0	0	0	0	
Annelida	Polychaeta	Sabellida	Sabellidae	Euchone		<i>Euchone</i> sp.	0	0	0	0	0	0	0	0	0	0	0	290	0	0	0	0	0	0	0	0	0	0	0	
Annelida	Polychaeta	Sabellida	Sabellidae			Sabellinae	377	0	0	0	0	0	0	580	0	58	0	0	0	522	0	0	0	0	0	0	0	0	0	
Foraminifera																														

Table 6.21 Endobenthic invertebrates densities (no. of organisms/m²) measured at sites Q1 and Q2, August 2012. (continuation)

Phylum	Class	Order	Family	Genus	Species	Scientific name	Q1						Q2									
							T1-1	T1-3	T2-5	T3-3	T3-5	T4-3	T5-1	T5-3	T5-5	T6-3	T7-1	T7-3	T7-5	T8-1	T8-3	T8-5
Arthropoda	Malacostraca	Cumacea	Lamproidae	Lamprops	fuscatus	<i>Lamprops fuscatus</i>	0	29	29	0	0	0	0	116	116	0	0	0	0	0	0	
Annelida	Polychaeta	Sabellida	Sabellidae	Laonome	kroyeri	<i>Laonome kroyeri</i>	0	0	0	0	0	0	0	0	0	0	0	0	0	290	0	
Annelida	Polychaeta	Terebellida	Terebellidae	Laphania	boeckii	<i>Laphania boeckii</i>	0	0	0	0	0	0	0	0	0	0	58	0	0	0	0	
Arthropoda	Malacostraca	Cumacea	Leuconidae	Leucon	nasicooides	<i>Leucon (Leucon) nasicooides</i>	0	0	0	0	0	0	0	0	116	0	0	0	0	0	0	
Bryozoa	Stenolaemata	Cyclostomatid	Lichenoporidae			Lichenoporidae spp.	0	29	0	0	0	0	0	0	0	29	0	0	0	0	0	
Mollusca	Gastropoda	Littorinimorph	Littorinidae	Littorina	obtusata	<i>Littorina obtusata</i>	0	0	0	0	0	116	0	0	0	0	2 145	0	0	1 420	0	
Mollusca	Gastropoda	Littorinimorph	Naticidae	Lunatia	pallida	<i>Lunatia pallida</i>	0	0	0	0	0	0	0	58	29	0	0	0	0	0	0	
Arthropoda	Malacostraca	Amphipoda	Lysianassidae			Lysianassidae spp.	290	29	0	0	29	29	0	0	0	406	0	58	0	0	0	
Annelida	Polychaeta	Terebellida	Ampharetidae	Lysippe	fragilis	<i>Lysippe cf. fragilis</i>	0	0	0	58	0	0	0	0	58	0	0	0	0	0	0	
Annelida	Polychaeta	Terebellida	Ampharetidae	Lysippe		<i>Lysippe sp.</i>	29	0	0	0	0	0	0	116	0	0	0	58	0	0	174	
Mollusca	Bivalvia	Veneroidea	Tellinidae	Macoma	balthica	<i>Macoma balthica</i>	0	0	0	0	0	0	0	0	0	116	0	0	29	0	0	
Mollusca	Bivalvia	Veneroidea	Tellinidae	Macoma	calcareea	<i>Macoma calcareea</i>	0	0	0	116	0	0	0	116	116	0	0	58	0	0	0	
Annelida	Polychaeta		Maldanidae			Maldanidae spp.	0	29	0	0	0	0	0	0	0	0	0	0	0	0	0	
Mollusca	Gastropoda		Turbinidae	Margarites	helicinus	<i>Margarites helicinus</i>	0	0	0	638	0	116	0	0	0	58	0	0	0	0	0	
Mollusca	Gastropoda		Turbinidae	Margarites		<i>Margarites sp.A</i>	0	0	0	0	0	0	0	58	0	0	0	0	0	0	0	
Arthropoda	Malacostraca	Amphipoda	Stenothoidae	Mesometopa	neglecta	<i>Mesometopa neglecta</i>	0	0	0	0	0	0	0	0	0	0	0	116	0	0	0	
Mollusca	Bivalvia	Myoidea	Myidae	Mya	pseudoarenaria	<i>Mya pseudoarenaria</i>	203	58	29	174	87	0	0	174	0	0	116	116	0	1 275	0	
Annelida	Polychaeta	Phyllodocida	Hesionidae	Microphthalmus		<i>Microphthalmus sp.A</i>	0	29	0	116	0	0	0	0	0	0	116	0	0	0	0	
Arthropoda	Malacostraca	Amphipoda	Oedicerotidae	Monoculodes	borealis	<i>Monoculodes borealis</i>	0	0	0	0	0	0	0	0	0	29	0	0	0	0	0	
Arthropoda	Malacostraca	Amphipoda	Oedicerotidae	Monoculodes	norvegicus	<i>Monoculodes norvegicus</i>	0	29	0	0	0	0	0	0	0	0	0	0	0	0	0	
Arthropoda	Malacostraca	Amphipoda	Oedicerotidae	Monoculopsis	longicornis	<i>Monoculopsis longicornis</i>	0	0	0	0	0	0	0	116	0	0	0	0	0	0	0	
Arthropoda	Malacostraca	Amphipoda	Pontoporeiidae	Monoporeia	affinis	<i>Monoporeia affinis</i>	0	0	0	0	0	0	0	0	0	29	0	0	0	0	0	
Mollusca	Bivalvia	Veneroidea	Montacutidae			Montacutidae spp.	0	203	0	0	0	0	0	464	0	0	0	174	0	0	0	
Mollusca	Bivalvia	Mytiloidea	Mytilidae	Mytilus		<i>Mytilus sp.</i>	0	0	0	406	0	232	0	0	0	0	0	0	0	1 217	0	
Arthropoda	Malacostraca	Nebaliacea	Nebaliidae	Nebalia	bipes	<i>Nebalia bipes</i>	0	0	0	0	0	116	0	0	58	0	0	0	0	0	0	
Nematoda							1 101	1 594	58	11 768	0	290	1 014	8 812	4 348	3 159	232	16 000	2 841	29	9 507	6 377
Annelida	Polychaeta	Eunicida	Lumbrineridae	Ninoe		<i>Ninoe sp.</i>	29	0	0	0	0	0	0	0	0	0	0	0	0	0	0	0
Mollusca	Bivalvia	Nuculida	Nuculidae	Nucula		<i>Nucula sp.</i>	0	0	0	0	0	0	0	0	0	0	0	0	0	0	0	58
Mollusca	Gastropoda	Neogastropod	Mangeliidae	Oenopota	arctica	<i>Propebela arctica</i>	0	0	0	0	0	0	0	0	0	0	0	58	0	0	0	0
Mollusca	Gastropoda	Neogastropod	Mangeliidae	Oenopota	bicarinata	<i>Oenopota c.f. bicarinata</i>	0	0	0	0	0	0	0	0	58	0	0	0	0	0	0	0
Annelida	Cliellata						1 188	319	0	290	0	87	6 377	2 087	754	812	406	232	116	232	348	1 391
Arthropoda	Malacostraca	Amphipoda	Uristidae	Onisimus	litoralis	<i>Onisimus litoralis</i>	0	0	0	0	0	0	0	0	0	29	0	0	0	0	58	0
Annelida	Polychaeta		Opheliidae	Ophelia	limacina	<i>Ophelia limacina</i>	29	174	0	116	0	0	0	0	0	58	0	174	0	0	9 391	0
Annelida	Polychaeta					Orbinidae spp.	0	29	0	0	0	0	0	0	0	29	0	0	0	0	58	0
Arthropoda	Malacostraca	Amphipoda	Lysianassidae	Orchomenella	minuta	<i>Orchomenella minuta</i>	0	0	0	116	0	0	0	0	58	58	0	174	0	0	464	0
Annelida	Polychaeta	Sabellida	Oweniidae			Oweniidae spp.	0	0	0	0	0	0	0	116	0	0	0	0	0	0	0	0
Annelida	Polychaeta		Paraonidae	Paraonella	nordica	<i>Paraonella nordica</i>	0	290	0	0	0	0	0	696	1 333	0	0	0	1 623	0	0	1 565
Arthropoda	Malacostraca	Amphipoda	Oedicerotidae	Paroediceros	lynceus	<i>Paroediceros lynceus</i>	0	0	0	0	0	0	0	0	116	0	0	0	0	0	58	0
Annelida	Polychaeta	Terebellida	Pectinariidae			Pectinariidae spp.	58	0	0	0	0	0	0	0	58	0	0	0	0	0	0	0
Mollusca	Gastropoda	Cephalaspide	Philinidae	Philine		<i>Philine sp.</i>	0	0	0	0	0	0	0	116	0	0	0	0	0	0	0	0
Arthropoda	Ostracoda	Mydocopida	Philomedidae	Philomedes		<i>Philomedes sp.</i>	0	29	0	0	0	0	0	464	174	0	0	754	0	0	0	58
Annelida	Polychaeta	Phyllodocida	Pholoidae	Pholoe	longa	<i>Pholoe longa</i>	2 464	493	0	1 681	0	0	0	1 623	464	1 014	0	32 058	1 101	0	19 420	3 362
Annelida	Polychaeta	Phyllodocida	Pholoidae	Pholoe		<i>Pholoe sp.</i>	3 623	2 841	174	3 710	203	348	0	1 159	2 725	0	87	5 681	1 159	0	13 159	4 348
Arthropoda	Malacostraca	Amphipoda	Photidae			Photidae spp.	0	0	0	0	0	0	0	0	58	0	0	0	0	0	0	0
Annelida	Polychaeta	Phyllodocida	Phyllodocidae	Phyllodoce	groenlandica	<i>Phyllodoce (Anaitides) groenlandica</i>	29	29	0	0	0	0	0	116	116	0	0	58	0	0	0	0
Annelida	Polychaeta	Terebellida	Terebellidae	Polycirrus		<i>Polycirrus sp.</i>	0	0	0	0	0	0	0	0	0	0	0	58	0	0	0	0
Arthropoda	Malacostraca	Amphipoda	Pontogeneiidae	Pontogeneia		<i>Pontogeneia sp.</i>	0	0	0	0	0	0	0	0	0	58	0	0	0	0	58	0
Arthropoda	Malacostraca	Amphipoda	Pontoporeiidae	Pontoporeia	femorata	<i>Pontoporeia femorata</i>	0	0	0	0	0	0	0	0	58	0	0	0	0	0	0	0
Mollusca	Bivalvia	Nuculanoida	Yoldiidae	Portlandia	arctica	<i>Portlandia arctica</i>	0	0	0	0	0	0	0	0	0	0	0	58	0	0	0	0
Annelida	Polychaeta		Maldanidae	Praxillella	praetermissa	<i>Praxillella praetermissa</i>	0	0	0	0	0	0	0	232	0	87	0	58	0	0	0	116
Annelida	Polychaeta		Maldanidae	Praxillella		<i>Praxillella sp.</i>	0	0	0	0	0	0	0	0	58	0	0	116	0	0	0	0
Cephalorhync	Priapulida		Priapulidae	Priapulus	caudatus	<i>Priapulus caudatus</i>	0	0	0	0	0	0	0	0	58	29	0	0	0	0	0	0
Annelida	Polychaeta	Spionida	Prionospio			<i>Prionospio sp.</i>	58	0	0	58	0	0	0	0	0	0	0	0	0	0	0	0
Arthropoda	Malacostraca	Amphipoda	Corophiidae	Protomeдея	fasciata	<i>Protomeдея fasciata</i>	0	174	0	0	0	0	0	0	0	0	0	1 275	0	0	7 768	0
Arthropoda	Malacostraca	Amphipoda	Corophiidae	Protomeдея	grandimana	<i>Protomeдея c.f. grandimana</i>	0	0	0	0	0	0	0	0	58	0	0	0	0	0	0	0
Arthropoda	Malacostraca	Amphipoda	Corophiidae	Protomeдея		<i>Protomeдея sp.</i>	0	0	0	0	0	0	0	0	58	0	0	0	0	0	0	0
Mollusca	Gastropoda	Cephalaspide	Retusidae	Retusa	obtusa	<i>Retusa obtusa</i>	0	29	0	0	0	0	0	0	0	29	0	0	0	0	0	0
Chordata	Asciacea	Stolidobranch	Molgulidae	Rhizomolgula	globularis	<i>Rhizomolgula globularis</i>	0	0	0	0	0	0	0	0	0	0	0	58	0	0	0	0
Annelida	Polychaeta	Sabellida	Sabellidae			Sabellidae spp.	0	0	0	0	0	0	0	0	0	0	58	0	0	58	0	0
Arthropoda	Ostracoda	Podocopida	Cytheridae	Sarsicytheridea		<i>Sarsicytheridea sp.</i>	0	29	29	0	0	0	0	4 290	5 565	174	29	58	1 043	0	0	0
Annelida	Polychaeta		Scalibregmatidae	Scalibregma	inflatum	<i>Scalibregma inflatum</i>	58	0	0	0	0	0	0	116	0	0	0	0	348	0	58	58
Bryozoa	Gymnolaemat	Cheilostomatid	Schizoporellidae	Schizoporella	costata	<i>Schizoporella c.f. costata</i>	0	0	0	0	0	0	0	0	29	0	0	0	0	0	0	0
Annelida	Polychaeta	Eunicida	Lumbrineridae	Lumbrineris	fragilis	<i>Lumbrineris c.f. fragilis</i>	0	29	87	0	29	0	0	0	348	0	0	58	0	0	0	58
Annelida	Polychaeta	Eunicida	Lumbrineridae	Scoletoma	impatiens	<i>Scoletoma c.f. impatiens</i>	29	0	0													

According to Figures 6.15 and 6.16, the proportion of the phyla composing the samples is similar between the two sites. In both cases, the annelids occupy more than half the samples, i.e. 56% and 61% for Q1 and Q2 respectively. The proportion of nematodes is almost identical at the two sites (20% and 19%). We should note that a small proportion of bryozoans, cnidaria and echinoderms were collected in the study zone (Table 6.21). The low abundance rates compared to the other phyla do not allow them to be distinguished in Figures 6.22 and 6.23.

The total density of organisms varies greatly from one site to another. The mean density of 28,154 organisms/m² found at site Q2 is more than double the mean density of 12,237 organisms/m² collected at site Q1. We should note that the mean density at site Q1 is in the same order of magnitude as the one during the 2007 campaign regarding the site of the future port facilities (19,057 organisms/m²).

Statistical analyses were applied to the data. The results of these analyses are indicated in Table 6.22. The specific richness (S) made it possible to count the species present at each station. The Shannon-Wiener index (H') was used to express the diversity of the sampled stations. This index allows the number and abundance of species to be taken into account for the same station. Finally, Pielou's evenness index (J'), allows calculation of the ratio of the observed diversity to the maximum diversity.

The number of different taxa identified in the 16 samples ranges from five (T5-1) to 62 (T5-5) (Table 6.22). The stations closest to the shore contain a lesser number of species than the stations farther away. Pielou's index ranges from 0.323 (T5-1) to 0.912 (T3-5). In the analysis of these results, station T3-5 shows a good distribution of abundance rates among species collected, while station T5-1 shows an abundance rate exceeding 80% for oligochaetes.

The highest values for the Shannon-Wiener diversity index are found at stations T7-5 (3.034), T5-5 (2.969) and T1-3 (2.859). Stations T8-1 (0.934) and T5-1 (0.520) recorded the lowest values. For the majority of the stations, for the same transect, the highest Shannon-Wiener index is found at the station farthest from the shore, namely at the stations with the greatest depth.

The mean specific richness values (S) for sites Q1 and Q2 respectively indicate a similar number of identified taxa (29 and 34). However, the mean Shannon-Wiener diversity index is higher at site Q1. Moreover, the highest value for the Pielou index shows a better distribution of the sampled species compared to site Q2.

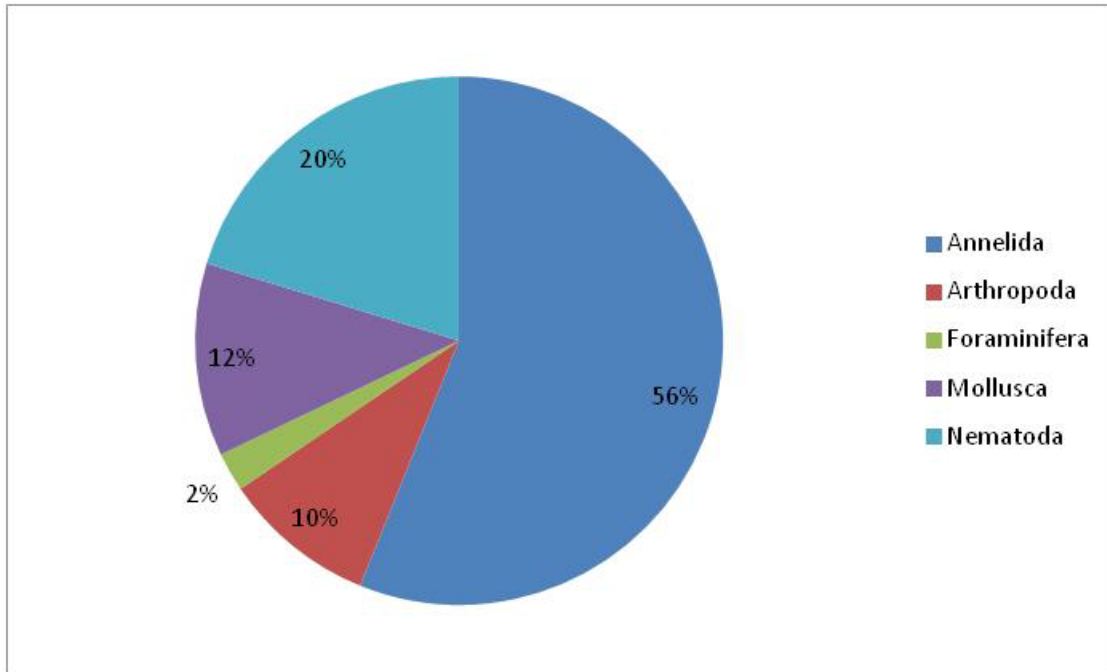

Figure 6.15 Proportions of phyla collected at site Q1, August 2012.

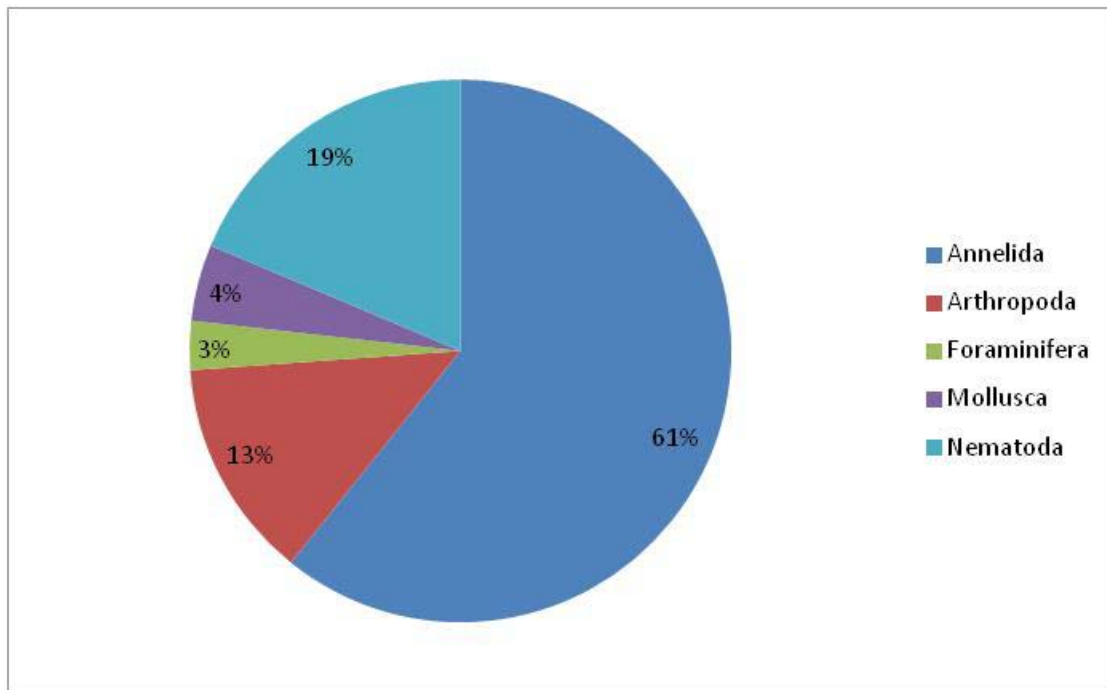

Figure 6.16 Proportions of phyla collected at site Q21, August 2012.

Table 6.22 Diversity indices for the 16 stations sampled at sites Q1 and Q2 in Deception Bay, August 2012.

Site	Station	S	J'	H'
Q1	T1-1	32	0.767	2.660
	T1-3	51	0.727	2.859
	T2-5	18	0.876	2.533
	T3-3	41	0.680	2.526
	T3-5	19	0.912	2.686
	T4-3	15	0.545	1.476
Mean	--	29.33	0.750	2.460
Q2	T5-1	5	0.323	0.520
	T5-3	45	0.724	2.756
	T5-5	62	0.719	2.969
	T6-3	40	0.650	2.398
	T7-1	10	0.620	1.428
	T7-3	30	0.478	1.625
	T7-5	50	0.776	3.034
	T8-1	8	0.449	0.934
	T8-3	32	0.615	2.130
	T8-5	29	0.606	2.040
Mean	--	34	0.600	1.980

S : specific richness
 J' : Pielou's evenness index
 H' : Shannon-Wiener index

6.2.1.3 Ichthyofauna

According to the previous information obtained from Inuit fishermen, sport fishermen working at the Raglan Mine and scientific fishing conducted in Deception Bay (Therrien *et al.*, 2008), the Arctic Char (*Salvelinus alpinus*), the Greenland Cod (*Gadus ogac*), the Arctic Cod (*Boreogadus saida*), sculpins and sticklebacks are the main fish species present in the bay. Among these, the Arctic Char, sticklebacks and sculpins are the most likely to use the coastline for their feeding and breeding activities (spawning, rearing) (Scott and Scott, 1988).

The Arctic Char is also associated with the pelagic zone, near the surface, and uses the bay only for summer feeding and migration. Its breeding occurs in fresh water. The Arctic Cod (or Arctic Tomcod) is mainly associated with the deeper pelagic zones. For the Greenland Cod, the information in the literature is too incomplete to document its use of coastal habitats (GENIVAR, 2008). However, the site Q1 habitat is not unique and is found elsewhere around Deception Bay.

The species captured during the September 2007 sampling operations contribute to improving the knowledge level of the fish populations of Deception Bay (GENIVAR, 2008). Some of these species could frequent shallower zones, such as

those near site Q1. They are the Shorthorn Sculpin, the Daubed Shanny (*Lumpenus maculatus*) and the Grubby. The Arctic Eelpout (*Lycodes reticulatus*), the Canadian Plaice (*Hippoglossoides platessoides*) and the Atlantic Cod (*Gadus morhua*) were also harvested in September 2007.

Table 6.23 presents a description of the fish species frequenting Deception Bay. This information is taken from Scott and Scott (1988) and the Fishbase website at <http://www.fishbase.org/>.

6.2.1.4 Marine Mammals

About ten marine mammal species can be found in Deception Bay, depending on their range (GENIVAR, 2007). Table 6.24 presents the list and summarizes the information gathered from the Inuit. Among these species, six are particularly of interest due to their abundance, their status and, above all, their use by the Inuit. They are the Beluga, the Minke Whale, the Ringed Seal the Harp Seal, the Bearded Seal and the Bowhead Whale.

The species observed during the acoustic pressure measuring work in Deception Bay in July 2012 are highlighted in grey in Table 6.24. One seal was observed on July 13, 2012 (Lat.: 62°14'9,359" N; Long.: 74°46'49,710"W), but its species could not be identified.

Marine mammals are defined in two main groups: whales and pinnipeds. Whales spend their entire lives in the water, while pinnipeds may share their life cycle between land and sea.

Whales are divided into two suborders:

- the Odontoceti, or toothed whales, such as the Beluga and the Killer Whale;
- the Mysticeti, or baleen whales, such as the Minke Whale or the Bowhead Whale.

The pinnipeds are divided directly into several families, such as:

- the Phocidae, including the seals;
- the Odobenidae, including the walruses.

Table 6.23 Main fish species present in Deception Bay, likely to use the study zone.

Species	Descriptions taken from Scott and Scott (1988)
Fourhorn Sculpin (<i>Myoxocephalus quadricornis</i>)	In general, this species is typical of shallow Arctic and sub-Arctic waters (estuarine coastal waters). It rarely descends to depths below 15 to 20 m and sometimes frequents rivers. Spawning occurs in late fall or in winter and an incubation period of 2 to 3 months is necessary to hatch the eggs (97 days at 1.5°C and 74 days at 2°C). The nest is made by digging a hole in soft algae masses or in a muddy bottom.
Shorthorn Sculpin (<i>Myoxocephalus scorpius</i>)	This species frequents shallow fresh waters (generally shallower than 37 m) and is often captured near wharfs, while looking for food. It spawns on rocky bottoms between 6 and 11 m deep. In Newfoundland, spawning occurs in early winter, and thus probably earlier in Deception Bay.
Grubby (<i>Myoxocephalus aeneus</i>)	The Grubby is found in coastal waters and tolerates temperatures ranging from 0 to 21.1°C, as well as a wide variation in salinity. In protected areas, it is found at depths of less than one metre on muddy, sandy, or gravelly bottoms, but between 5 and 15 m along exposed (unprotected) coasts on rocky bottoms. It is abundant throughout the eelgrass and probably spawns in winter.
Three-spined Stickleback (<i>Gasterosteus aculeatus</i>)	This stickleback species frequents the shallow zones located near the coasts, especially in brackish water. It prefers temperate waters to Arctic waters. When it is offshore, it often stays among the floating algae. Spawning, which occurs in fresh or brackish water, occurs from April to September, depending on the latitude. In the case of Deception Bay, it thus probably occurs around the month of September.
Ninespine Stickleback (<i>Pungitius pungitius</i>)	This stickleback is found in salt water or brackish water, generally confined near the coasts. It likes habitats with a lot of vegetation that lets it protect itself from predators. For this species this is also a hospitable environment for making a nest. Spawning occurs during the summer, and thus probable around the month of August in Deception Bay, in fresh or brackish water.
Daubed Shanny (<i>Leptoclinus maculatus</i>)	The Daubed Shanny is present in shallow waters, from about 2 m below the low tide mark up to over 100 m. Offshore from Labrador, it has been captured at depths from 27 to 110 m on muddy, sandy or rocky bottoms. Spawning occurs in winter in shallow waters.
Arctic Eelpout (<i>Lycodes reticulatus</i>)	The Arctic Eelpout generally frequents shallow waters. It mainly feeds on epibenthos.
Arctic Cod (<i>Boreogadus saida</i>)	A pelagic species that lives in the upper part of the water column, the Arctic Cod is often found on the surface and near floating ice. It mainly feeds on plankton, and adults occasionally may eat the young of their own species. Spawning occurs under the ice cover, from December to March. The Arctic Cod is the prey of several marine mammal, seabird and fish species.
Atlantic Cod (<i>Gadus morhua</i>)	The Atlantic Cod lives in the coastal zone, up to the edge of the continental shelf, in cold waters (up to about 10°C). The juveniles prefer shallow waters in protected areas. The Atlantic Cod is an omnivorous species that feeds at the seabed. It can breed in the Arctic beginning in February, and later to the south. Spawning occurs in a wide variety of habitats.

Table 6.23 Main fish species present in Deception Bay, likely to use the study zone (continued).

Species	Descriptions taken from Scott and Scott (1988)
Arctic Char (<i>Salvelinus alpinus</i>)	<p>The Arctic Char is an anadromous species feeding in the sea. The young individuals spend several years in a lake or river before going to sea. The downstream migration generally occurs in the spring, a little before or during the ice break-up, or in early summer. The return to the river estuaries occurs in August. Spawning occurs in September and October in fresh water, on gravelly bottoms of lakes or river troughs, at depths of 1 to 4 m. The eggs take all winter to develop. The Arctic Char is carnivorous and feeds on a wide variety of fish. Apart from seals, the Arctic Char has few predators.</p>
Greenland Cod (<i>Gadus ogac</i>)	<p>This species is more common near the coasts than offshore and tolerates water that is low in salt. It is a coldwater fish that likes coastal waters (Fontaine, 2006). The Greenland Cod spawns between February and March, along the coasts or in brackish water. The species is found from the Arctic, along the coasts of Labrador, around Newfoundland and in the Gulf of St. Lawrence, at least as far as Les Escoumins.</p>
Canadian Plaice (<i>Hippoglossoides platessoides</i>)	<p>The Canadian Plaice is a bottom fish and lives in cold, deep waters (generally from 90 to 250 m). It feeds on invertebrates and small fish. It breeds in spring at great depths.</p>
Arctic Shanny (<i>Stichaeus punctatus</i>)	<p>A benthic species present in cold, deep waters, the Arctic Shanny has been observed up to 55 m deep in Hudson Bay. The juveniles, observed in Newfoundland, live on pebble and gravel bottoms. The species is territorial. The adults prefer rocky substrates, where they hide under rocks and in crevasses. Breeding occurs from February to March. A female may contain thousands of eggs. The planktonic larvae develop from June to August between depths of 10 and 110 m. The juveniles' food essentially consists of copepods and amphipods, while the adults feed on polychaetes and different groups of crustaceans. This species cohabits with several cottid species.</p>

Table 6.24 Marine mammals likely to use Deception Bay

French name	English name	Latin name	Relative abundance ²	Remark
Béluga¹	White Whale, or Beluga	<i>Delphinapterus leucas</i>	Medium	The Beluga is hunted in Deception Bay by the Inuit of Salluit.
Narval ¹	Narwhal	<i>Monodon monoceros</i>	Rare	Observed more often in the past.
Épaulard	Killer Whale	<i>Orcinus orca</i>	Low	Observed more often in Deception Bay in the past few years. Variable presence from year to year. The Killer Whale is not hunted by the Inuit.
Petit rorqual	Minke Whale	<i>Balaenoptera acutorostrata</i>	Medium	Often observed in Deception Bay.
Baleine boréale ¹	Bowhead Whale	<i>Balaena mysticetus</i>	Rare	Occasionally frequents Deception Bay. A few individuals are observed there each year.
Morse	Walrus	<i>Odobenus rosmarus</i>	Rare or absent	Not observed in Deception Bay.
Phoque annelé	Ringed Seal	<i>Phoca hispida</i>	High	Species most hunted by the Inuit and appears along the coasts all year long.
Phoque du Groenland	Harp Seal	<i>Pagophilus groenlandicus</i>	Unknown	Species hunted by the Inuit, especially in the fall.
Phoque barbu	Bearded Seal	<i>Erignathus barbatus</i>	Unknown	Stable population according to the Inuit interviewed. Species hunted by the Inuit.
Phoque commun	Harbour Seal	<i>Phoca vitulina</i>	Rare or absent	Species not reported by the Inuit interviewed.

¹ Species at risk (Québec: species with a precarious status)

² According to the testimony of the Inuit interviewed (GENIVAR, 2007).

Table 6.25 summarizes the characteristics of the main marine mammals likely to frequent Deception Bay.

Beluga

The Beluga populations live mainly in the High Arctic region between latitudes 50° and 80° N (Perrin *et al.*, 2002). They live in icy waters, especially within polynyas and leads present in the ice cover they use to breathe. The Beluga has an irregular distribution around the Arctic Circle (Rice, 1998). This species migrates seasonally according to the limits of the ice shelf, as it retreats northward or expands southward.

The Beluga populations likely to use Deception Bay are those of western and eastern Hudson Bay, and the Ungava Bay population. The last two are designated as endangered.

The Ungava Bay population has never been large (1,000 Belugas in 1870; Beaulieu, 1992 in GENIVAR, 2007b). Decimated by commercial exploitation and subsistence hunting, its abundance is now estimated at fewer than 100 individuals (Environment Canada, 2004). The population of eastern Hudson Bay is mainly concentrated in the

estuaries of the Nastapoka River and the Little Whale River during the summer. This population includes about 2,000 to 3,000 Belugas, but is in sharp regression (COSEWIC⁶, 2004a). Indeed, this population declined from about 4,200 individuals in 1985 to 3,100 in 2004 (Hammill and Stenson, 2005). The western Hudson Bay population includes about 22,000 to 23,000 individuals (COSEWIC, 2004a). The Belugas of these three populations migrate in the fall to Hudson Strait, where they will spend the winter. Some of these Belugas are likely to use Deception Bay, which is confirmed by Inuit hunters (Don Cameron, Nuvumiut Developments Inc., pers. comm., 2007), but their number is indeterminate and probably very low, because these three populations make a winter migration to Hudson Strait, while some individuals would spend the summer in the bay instead of returning to their respective place of origin.

During breeding (mating), the Belugas reach their summer territory: bays, estuaries and other shallow waters. The female Belugas calve from mid-March west of Greenland to late August in Hudson Bay, after a gestation period of 12 to 14 months. The females breed every two or three years (Lentifer, 1988).

The females and their young prefer the calm and shallow waters along the edges of reefs and near islands and large bays. The surface water is warmer at these locations, free of ice in summer, which reduces heat losses in the young and favours moulting. The adults and the weaned young instead favour areas where the depth varies and where the surface water is maintained at a cold temperature. Sandy, gravelly or muddy bottoms are rich in molluscs, crustaceans and demersal fish on which the Belugas feed (DFO, 2007a).

Before the winter ice forms, the Belugas begin their fall migration, moving along the coastal zones of the bays to head out to sea. Most then go as far as the progression of the ice shelf, ending up in the leads and polynyas. Their movements are then determined by the presence of ice and the quantity of fish. According to a satellite telemetry study conducted by Pierre Richard (DFO, 2007b), Belugas migrate over distances much greater than were believed. Instead of staying near the coasts in zones of open water and detached ice, Belugas often travel hundreds of kilometres under the ice shelf. Thus, some groups remain under the ice, surviving thanks to unfrozen areas of the ice shelf that allow them to breathe, or thanks to air pockets trapped under the ice. Belugas are thus able to find zones by echolocation where the ice is so thin that they can break it to breathe on the surface, whereas more than 95% of the ice shelf is too thick to allow this.

⁶ Committee on the Status Endangered Wildlife in Canada.

Table 6.25 Characteristics of the main marine mammals likely to frequent Deception Bay (GENIVAR, 2007b).

Species	Population	Special status	Period of frequentation of Deception Bay	Breeding period	Preferred habitat	Special sensitivity	Acoustics	Hunted by the Inuit
Beluga	Indeterminate, but probably a very small percentage of the Hudson Bay (east and west) and Ungava Bay populations, which total about 25,000 individuals.	Endangered (COSEWIC, May 2004).	<u>Summer:</u> feeding, moulting, resting young. <u>Winter:</u> incursion into the bay according to hunters (Don Cameron, pers. comm., 2007)	<u>Mating:</u> late winter, early spring (COSEWIC, 2004). <u>Calving:</u> once every 3 years, between April and June (Environment Canada, 2004).	<u>In summer:</u> bays, estuaries shallow waters, reefs and islands, sandy, gravelly and muddy bottoms. <u>In winter:</u> leads and polynyas, Hudson Strait (Environment Canada, 2004).	Masking effect by low-frequency sounds on the high-frequency sounds used for communication and echolocation.	<u>Echolocation:</u> from 30 to 130 k Hz and higher. <u>Communication:</u> Frequency of 1 to 20 kHz; intensity of 100 to 180 dB (re 1 µPa at 1 m).	Yes; main threat of extinction, (Environment Canada, 2004).
Minke Whale	6,000 west of Greenland (North Atlantic population) (COSEWIC, 2002)		In open water.	<u>Mating:</u> December to May <u>Calving:</u> November to March	Coastal zones.	Curious whale that easily approaches boats.	<u>Communication:</u> frequency of 80 Hz to 20 kHz.	No
Bowhead Whale	11,000		In open water.		Bays, straits and estuaries; near floating ice.	Moves slowly (7 km/h) and is more susceptible to collide with boats.	<u>Communication:</u> 0.02 – 0.9 kHz (WDCS, 2004).	Object of small-scale and very well-managed subsistence hunting.
Ringed Seal	Indeterminate.	Mid priority species (Group 2) COSEWIC	<u>Breeding:</u> moulting and resting on the ice shelf in May. <u>Feeding:</u> in July and August, near the shore. <u>Migration:</u> September to October. <u>Wintering sites:</u> along the coasts	<u>In summer:</u> bays and near the shores. <u>In winter:</u> polynyas, floes, coastal ice shelf.	<u>Calving:</u> from mid-March to mid-April on the ice shelf.		Auditory sensitivity < 1 kHz. Auditory system adapted to air and water.. Communication ranges: 100 Hz to 15 kHz. Cries, barks, whistles.	~ 2,000 captures/year in the Labrador region. By far the most hunted marine mammal and the most important in terms of food and the economy for the Inuit of Deception Bay.
Harp Seal	Northwest Atlantic population (from Newfoundland).	Low priority species (Group 3) COSEWIC	<u>March to April:</u> calving, resting and weaning young. <u>Summer:</u> feeding, resting and moulting.	<u>Late March to early April:</u> Drift ice.	<u>Mating:</u> from mid-March to late March on the ice shelf. <u>Calving:</u> late February and early March on the ice shelf.			Little hunted.
Bearded Seal	Population little studied, minimal		<u>Summer:</u> feeding, resting and moulting. <u>Fall:</u> strong currents at the outlet of the bay.	<u>In summer:</u> feeds in rivers at high tide.	<u>Mating:</u> in April and May on drift ice.			In fall, near the coasts and within the bays.

The Belugas are toothed whales, with very well developed hearing. They are capable of echolocating, i.e. emitting a series of sounds resembling clicks, which bounce off fish and other submerged objects, allowing them to reconstitute an accurate image of their surroundings (DFO, 2007a). This type of sound is emitted at 30 to 130 kHz or more (Richardson *et al.*, 1995). Most of the sounds serving as a means of communication within a group are emitted at frequencies of 1 to 20 kHz and intensities of 100 to 180 dB (re: 1 µPa at 1 m, see subparagraph 5.1.1.1). These sounds are often associated with a specific behaviour (DFO, 2007a). This natural sonar is essential to a species that lives a large part of its life in the dark ocean waters. Belugas make frequent dives of several hundred metres to depths where there is no light. This low visibility may be similar to certain conditions in shallower water, particularly silt runoff into river estuaries or ice cover and short polar winter days.

Minke Whale

The Minke Whale is found in every ocean in the world, from the tropics to the polar seas, in coastal and extracoastal waters. The Minke Whale population frequenting Deception Bay belongs to the North Atlantic population (COSEWIC, 2002). The total population is said to be around 15,000 individuals, including 6,000 west of Greenland, 1,000 in the Gulf of St. Lawrence, 3,000 on the Nova Scotia Shelf, and probably at least 5,000 in Newfoundland and Labrador. Mortality attributable to human activities, primarily hunting, does not currently exceed the population replacement threshold (COSEWIC, 2006).

The Minke Whale is a relatively coastal species living in most seas, feeding on krill and small fish. It is a baleen whale that does not need to echolocate, because it feeds on small organisms that are everywhere in the water. However, the Minke Whale can produce very varied sounds ranging from 80 Hz to over 20 kHz, similar to low-frequency “grunting”. It is a curious whale and easily approaches boats. Mating occurs between December and May; the females generally give birth once a year or every two years; they calve from November to March and look after their young for four to five months (Sergeant, 1963 and Stewart and Leatherwood, 1985 in Biorex Inc., 1999).

Very few details are known about the Minke Whale’s seasonal movements (DFO, 1999). At the beginning of 2000, several individuals were observed by the Inuit in Deception Bay (GENIVAR, 2007b).

Bowhead Whale

Bowhead Whales are found in the Western and Eastern Arctic. The population is estimated at about 11,000 individuals. According to recent information from the Inuit and aerial surveys, the Bowhead Whale population is increasing and they occasionally frequent Deception Bay (GENIVAR, 2007b).

During the summer, the Western population is found in the Beaufort Sea and the Arctic Ocean. Between fall and spring, the Bowhead Whales migrate to Alaska. The groups migrate north and south, following the drift ice. Bowhead Whales prefer bays, straits and estuaries and generally do not stay very far from floating ice plates.

Bowhead Whales are well adapted to the Arctic climate and are among the noisiest in their category. During their migration, they may travel in groups of fifteen individuals and are capable of communicating over an area of 25 to 50 km² to maintain contact with each other. Their acoustic capabilities also let them use the reverberations of their calls to help gauge the thickness of the floating ice plates (Environment Canada, 2004). They are able to break thick Arctic ice layers to create breathing holes.

According to a COSEWIC report (2005), Bowhead Whales are sexually active a large part of the year, although the study of fetuses shows that most conceptions happen in late winter or early spring (e.g. Koski *et al.*, 1993). Gestation lasts 13 to 14 months (e.g. Nerini *et al.*, 1984) or 12 to 16 months (e.g. Tarpley *et al.*, 1988). The females give birth to only one calf per pregnancy. Calving generally occurs during the spring migration, between April and early June (e.g. Koski *et al.*, 1993), and culminate in May (e.g. Nerini *et al.*, 1984).

Nowadays, well-managed small-scale subsistence hunting is practiced, posing no risk for this population. In the past, the Arctic Bowhead Whale population was decimated by commercial overfishing. In 1915, Canada banned large-scale whale hunting and the species had been designated as *endangered* by COSEWIC in the early 1980s. In 1991, the Eastern Arctic Bowhead Whale population was estimated at fewer than 1,000 individuals. About 350 Bowhead Whales remain in the Baffin Island sectors, a marked decline relative to the 11,000 individuals counted in the 1800s. According to recent information from the Inuit and aerial surveys, the Bowhead Whale population increased in the past few years.

Today, increased marine traffic threatens this species, because it is a source of collisions with slow-moving Bowhead Whales (7 km/h). Noise pollution also chases frightened whales far from their feeding area (Environment Canada, 2004).

Bowhead Whales occupy a relatively narrow niche in the upper latitudes of the extreme Arctic and can be disturbed by certain anthropogenic factors, such as underwater noise, and by climate change that could melt the ice shelf, thereby reducing the refuges against predation by Killer Whales even further (COSEWIC, 2005).

Seals

The three pinniped species that use Deception Bay for one of the phases of their life cycle and whose abundance induces the Inuit to hunt them are the Ringed Seal, the Harp Seal and the Bearded Seal.

Seals living in the Arctic region are particularly vulnerable to changes in the characteristics of this environment, because they largely depend on the ice shelf to feed, breed, moult and rest (Canadian Food Inspection Agency [CFIA], 2005). Seals mainly use Deception Bay during the summer period to feed along the coasts (GENIVAR, 2007b). Some species, such as the Bearded Seal, swim up the rivers at high tide in search of fish. In winter, the seals move and search for their food in the water, but must return to a solid platform to breed. They then use two types of ice: the coastal ice shelf, normally attached to land and which remains in place all winter, and drifting pack ice, which forms in high water zones or along land before separating from it.

The two species most frequently observed and hunted in Deception Bay are the Ringed Seal and the Harp Seal. They belong to the list of candidate threatened or vulnerable species defined by COSEWIC (June 14, 2007) and are ranked respectively as mid priority species (Group 2) and low priority species (Group 3) (COSEWIC, 2006).

Ringed Seal

The Ringed Seal is the principal marine mammal frequenting Deception Bay. It represents the most abundant species in the Arctic by far. Although no estimate of the size of the Ringed Seal population in Canada has been established, the density of this species seems to remain stable, despite the fluctuations of hunting intensity and the growth of industrial activity. In the past few years, no more than 2,000 individuals have been harvested annually by hunting in the Labrador region (COSEWIC, 2002).

These seals essentially feed on amphipods and fish (CFIA, 2005). They are very well adapted to the Arctic, because they are able to maintain breathing holes in the thick ice layer. Ringed Seals therefore can occupy zones inaccessible to most other species.

In May, the Ringed Seal uses the ice shelf exclusively to breed, moult and rest. In July and August, the groups disperse to the bays to feed near the shore. Then they regroup in September and October, heading to wintering sites along the coasts (Roche, 1992c).

Polynyas, floes and ice shelf edges then provide precious habitats for seals. Despite their small size, Ringed Seals survive extreme thermal conditions by digging lairs in the snow, directly on the ice shelf. They need moderately rough ice, which creates fairly large snow banks for the females to dig a lair (CFIA, 2005). They give birth in these lairs between mid-March and mid-April. Since the only access is underwater, this niche serves as refuge for the newborn pups against bad weather and predators (GENIVAR, 2007b). According to some authors (Smith and Hammill, 1980; 1981), the ice cover is shared so that individuals are associated with a small number of lairs and air holes under the snow, and so that the range of their movements is limited by the establishment of their respective territory.

Ringed Seals, because of their number, their nutritional quality and their economic interest, are the most important marine mammal species for the Inuit communities hunting in Deception Bay.

Harp Seal

The Harp Seal is a highly gregarious and migratory species. The global population is 7 million individuals (Lavigne, 2002 *in* FCIA, 2005). The species is divided into three distinct populations, including one that breeds near Newfoundland (Northwest Atlantic). Part of this population breeds on the ice cover drifting southward, off the coast of southern Labrador.

The adults mainly feed on small fish, such as capelan, herring or cod, but also on krill and amphipods. Harp Seals are present in great numbers on the waterways in summer. In each region, the groups generally concentrate on the ice shelf in two calving areas measuring 20 to 200 km and including up to 2,000 adult females per kilometre. Harp Seals always breed on the ice shelf. Towards late February or early March, the females give birth. Then they nurse their young and mate from middle to late March. The pups grow rapidly after birth, increasing in weight from about 10 kg at birth to 30 kg after 12 to 14 days (Bowen, 2006).

The survival of the newborn depends on the stability of the habitat during their first weeks of existence. In the Deception Bay region, this stability is assured up to late March or early April by maintenance of the Arctic ice. The females take advantage of

these stable zones, where they can nurse their young or rest after weaning, before starting to swim (CEMAM⁷, 2006). This stability can also be found on the drifting pack ice, where the Harp Seals are generally gathered.

Bearded Seal

The Bearded Seal has a circumpolar range. No reliable estimate exists of Arctic Bearded Seal populations (GENIVAR, 2007b). However, they are much less abundant than Ringed Seals and Harp Seals.

The Bearded Seal also knows how to maintain breathing holes in the ice shelf. It breeds (mates) in April and May on ice drifting along the coasts, but occasionally may come to land during the summer. Thus, no specific location can be identified for its breeding.

In July and August, Bearded Seals mainly enter at high tide into rivers such as the Wakeham River and the southeast arm of Douglas Harbour (Roche, 1992c) to feed mostly on Arctic Char, but also on molluscs and other invertebrates living in shallow water (CFIA, 2005).

The groups move offshore or into the bays, all summer long, depending on the ice conditions. Bays such as Deception Bay or Whitley Bay are thus a particular concentration area for seals, which rest and moult there (Roche, 1992c).

Bearded Seals gather in the fall in sectors where marine currents are strong (Roche, 1992c), such as the outlet of Deception Bay. The migrations resume and the seals rest on the newly formed ice in Hudson Strait. Hunting occurs during this period, near the coasts within the bays.

6.2.1.5 Special-Status Species

Among the species listed in Table 6.27, the Beluga is designated as endangered by the Species at Risk Act (S.C. 2002 ch-29). In Québec, the Beluga populations of eastern Hudson Strait and Ungava Bay have the status of species likely to be designated threatened or vulnerable.

Moreover, COSEWIC (2011) has granted the status of species of special concern to the Killer Whale, the Bowhead Whale, the Walrus and the Narwhal. These statuses are only COSEWIC recommendations and are not an official designation granted by Appendix 1 of the Species at Risk Act. However, it is important to take them into consideration in this environmental assessment.

⁷ Centre of Expertise in Marine Mammalogy

Finally, the Ringed Seal and the Harp Seal are species suspected of being at risk and thus are on the COSEWIC list of candidate species. They necessitate the production of status reports.

A request for information was filed with the Centre de données sur le patrimoine naturel du Québec (CDPNQ) on October 20, 2011 (Appendix 12) to verify the existence of data on the presence of threatened or vulnerable wildlife species, or species likely to be so designated, or species that are rare in the Deception Bay sector. The CDPNQ does not possess such data.

6.2.2 Terrestrial Environment

6.2.2.1 Flora

The plant communities identified during the inventory of threatened or vulnerable vascular species (Appendix 13) are: marine shoreline, shrubland, wet meadow, snowbed, mesic meadow, dry tundra, rocky tundra and ponds (shallows). The other environments are anthropogenic environments and sectors that are apparently still snow-covered at the end of the summer (Lauriol et al, 1984). The mapping of these communities is illustrated in Map 1 of Appendix 13. The following descriptions are extracted from that same Appendix.

Marine Shoreline

The marine shoreline contains two environments: sand-gravelly shoreline and salt marsh. Sand-gravelly shoreline appears as a more or less open meadow, dominated by Sea Lyme-grass (*Leymus mollis*) and marking the mean high level of the current marine shoreline. Salt marsh, regularly submerged by the tide, is a wet shortgrass meadow colonizing fine deposits and mainly consisting of graminoids, especially Creeping Alkaligrass (*Puccinellia phryganodes*).

Shrubland

Shrubland is dominated by herbaceous plants, but shrubs are also found there, mainly willows (*Salix glauca*, *S. planifolia*), which can reach heights of 1 or 2 m. This plant formation is most often linear and is observed along some watercourses, in sheltered sites benefiting from good winter snow cover.

Wet Meadow

Wet meadow colonizes fine deposits more or less saturated with water. This meadow is dominated by sedges (*Carex aquatilis*, *C. rariflora*), cotton grasses (*Eriophorum angustifolium*, *E. scheuchzeri*) and graminoids (*Arctagrostis latifolia*, *Dupontia fisheri*). This meadow is encountered in valley bottoms and at the base of snowbeds. Most of the plants associated with wetlands are found in this environment.

Snowbed

Snowbeds are a special environment. Generally located in the face of the prevailing winds, snowbeds occupy topographical sites that not only favour a large accumulation of windblown snow (Payette and Lajeunesse, 1980; Lauriol et al, 1984), but an increase in this snow's density (Payette et al, 1973). Consequently, the plants colonizing this environment benefit from snow cover, but snow removal delays considerably reduce the length of the growing season. Snowbeds harbour a number of chionophilic species, meaning that they are adapted to heavy snow conditions, such as Snow Buttercup (*Ranunculus nivalis*), Pygmy Buttercup (*R. pygmaeus*), Lapland Dandelion (*Taraxacum lapponicum*) and Twotipped Sedge (*Carex lachenalii*). In the study zone, the snowbeds observed are located at low altitude and are generally site-specific or small in area. These snowbeds are not mapped. They are distributed on the east or northeast slopes, most of them at the boundary line between mesic meadow and wet meadow. At higher altitudes, between mesic meadow and dry tundra, other snowbeds are found that seem to remain snow covered at the end of the summer (Lauriol et al, 1984). These more extensive snowbeds are mapped.

Mesic meadow

Mesic meadow colonizes the vast majority of the loose deposits of the sites that are not too wet or too exposed. Mesic meadow is dominated by graminoid plants, such as Bigelow's Sedge (*C. bigelowii*), Alpine Sweetgrass (*Anthoxanthum monticola* ssp. *alpinum*) and Arctic Bluegrass (*Poa arctica*), through which a wide diversity of plantlife is found. Mesic meadow is located above wet meadow and colonizes all the slopes covered with loose deposits.

Dry Tundra

Dry tundra is an open formation colonizing loose deposit sites that are very well drained and generally exposed. The vegetation is disseminated and particularly includes very rustic graminoid plants, such as Northern Woodrush (*Luzula confusa*) and cushion plant species, such as Moss Campion (*Silene acaulis*) or Pincushion Plant (*Diapensia lapponica*).

Rocky Tundra

Rocky tundra, which can include any mineral habitat with little or no vegetation, mainly consists of bedrock outcrops. Essentially the same type of vegetation is found there as in dry tundra.

Ponds

Ponds or shallows include the few water bodies supporting some kind of aquatic vegetation. The most frequent species, although providing negligible coverage, are Vernal Water-stanwort (*Callitriche palustris*) and High Northern Buttercup (*Ranunculus hyperboreus*).

Anthropogenic Environments

Although often disturbed recently, the anthropogenic environments can support several plant species, which shows the capacity of several Arctic plant species to play a pioneering role.

Special-Status Species

Four plants of interest were inventoried in the study zone selected for the inventory of threatened or vulnerable vascular species (Appendix 13). These plants are likely to be designated threatened or vulnerable species in Québec (CDPNQ, 2008; Québec, 2012). They are Smooth Northern-Rockcress (*Braya glabella* ssp. *glabella*), Dwarf Hairgrass (*Deschampsia sukatschewii*), Bluff Cinquefoil (*Potentilla arenosa* ssp. *chamissonis*) and Vahl's Cinquefoil (*Potentilla vahliana*). These plants share the characteristic of being at the southern limit of their range.

6.2.2.2 Mammals

According to the observations made during the 2006 field campaign (Therrien *et al.*, 2007), only burrows of small rodents, probably Ungava Lemming (*Dicrostonyx hudsonius*), were observed near site Q1. However, according to other observations performed nearby, several other wildlife species might use the disposal site sector. This is particularly the case for Arctic Fox (*Alopex lagopus*) and Caribou (*Rangifer tarandus*), which both have been noticed near the former outfitting establishment (Kanguq) and which are common species in the region. This outfitting establishment, which no longer exists, was located about 2 km upstream from the mouth of the Deception River.

More specifically, concerning Caribou, the Deception Bay sector is frequented by a subgroup of the Rivière-aux-Feuilles herd. This herd's population is said to be declining (Serge Couturier, pers. comm., 2012). The Deception Bay sector is very important for this subgroup. It is located within the migration area, but not within the calving area, which is farther south near the Raglan Mine.

In addition, the impact study (GENIVAR, 2007a) reports 12 land mammal species that potentially could frequent this region. These species are listed in Table 6.26.

Table 6.26 Land mammals likely to be present in the Deception Bay sector

French name	Latin name	English name	Relative abundance
Lemming d'Ungava	<i>Dicrostonyx hudsonius</i>	Ungava Lemming	Low to high ²
Campagnol des champs	<i>Microtus pennsylvanicus</i>	Meadow Vole	Low to high ²
Lièvre arctique	<i>Lepus arcticus</i>	Arctic Hare	Low to medium
Caribou	<i>Rangifer tarandus</i>	Caribou	Low to high ³
Boeuf musqué	<i>Ovibos moschatus</i>	Muskox	Low
Carcajou ¹	<i>Gulo gulo</i>	Wolverine	Rare
Hermine	<i>Mustela erminea</i>	Ermine	Medium
Belette pygmée ¹	<i>Mustela nivalis</i>	Least Weasel	Low
Renard arctique	<i>Alopex lagopus</i>	Arctic Fox	Low to medum ²
Renard roux	<i>Vulpes vulpes</i>	Red Fox	Low
Loup	<i>Canis lupus</i>	Wolf	Low
Ours blanc ¹	<i>Ursus maritimus</i>	Polar Bear	Low

Source: GENIVAR, 2007a.

1 Special-status species.

2 The abundance of the species varies according to a cycle of about 3 to 5 years.

3 The abundance of Caribou varies according to the season.

6.2.2.3 Avifauna

Appendix 14 presents the complete results of the avian fauna inventories conducted in 2012 in Deception Bay and the terrestrial environment near the projected structures.

A total of 41 bird species were observed within the study zone, including the Peregrine Falcon (subparagraph 6.2.2.4). The presence of 19 waterfowl and aquatic bird species was surveyed (10 Anatidae species, three loon species, five gull species and the Black Guillemot), five bird of prey species, 12 terrestrial species and five shorebird species.

The most abundant species were:

- the Canada Goose and the Common Eider among aquatic birds;
- the Lapland Longspur, the American Pipit, the White-crowned Sparrow, the Horned Lark and the Savannah Sparrow among terrestrial birds.

Table 6.27 presents the list of observed species. Breeding was confirmed for 27 species, while it was considered possible or probable for 9 others.

6.2.2.4 Special-Status Species

A request for information was submitted to the CDPNQ on October 20, 2011 (Appendix 12) to verify the existence of data on the presence of threatened or vulnerable wildlife species or those likely to be so designated, or rare species in the Deception Bay sector. The CDPNQ does not have data for this sector.

Land Mammals

Among the land mammal species listed in Table 6.26, the Wolverine is on the List of Threatened or Vulnerable Wildlife Species in Québec (MRN, 2012), in addition to being considered “endangered in Canada” (COSEWIC, 2006). The Least Weasel and the Polar Bear are on the List of Wildlife Species Likely to be Designated Threatened or Vulnerable in Québec (MRN, 2012) and the Polar Bear is also considered to be a species “of special concern” by COSEWIC (2006).

Table 6.27 List of bird species observed in the study zone

French name	Scientific name	English name	Breeding status
Alouette hausse-col	<i>Eremophila alpestris</i>	Horned Lark	Confirmed
Bécasseau à croupion blanc	<i>Calidris fuscicollis</i>	White-rumped Sandpiper	Non-breeding
Bécasseau de Baird	<i>Calidris bairdii</i>	Baird's Sandpiper	Non-breeding
Bécasseau semipalmé	<i>Calidris pusilla</i>	Semipalmated Sandpiper	Confirmed
Bécasseau variable	<i>Calidris alpina</i>	Dunlin	Non-breeding
Bernache de Hutchins	<i>Branta hutchinsii</i>	Cackling Goose	Possible
Bernache du Canada	<i>Branta canadensis</i>	Canada Goose	Confirmed
Bruant à couronne blanche	<i>Zonotrichia leucophrys</i>	White-crowned Sparrow	Confirmed
Bruant des prés	<i>Passerculus sandwichensis</i>	Savannah Sparrow	Confirmed
Buse pattue	<i>Buteo lagopus</i>	Rough-legged Hawk	Probable
Canard noir	<i>Anas rubripes</i>	American Black Duck	Possible
Canard pilet	<i>Anas acuta</i>	Northern Pintail	Confirmed
Cygne siffleur	<i>Cygnus columbianus</i>	Tundra Swan	Confirmed
Eider à duvet	<i>Somateria mollissima</i>	Common Eider	Confirmed
Eider à tête grise	<i>Somateria spectabilis</i>	King Eider	Confirmed
Faucon gerfaut	<i>Falco rusticolus</i>	Gyrfalcon	Possible
Faucon pèlerin	<i>Falco peregrinus</i>	Peregrine Falcon	Confirmed
Goéland arctique	<i>Larus glaucoides</i>	Iceland Gull	Confirmed
Goéland argenté	<i>Larus argentatus</i>	Herring Gull	Confirmed
Goéland bourgmestre	<i>Larus hyperboreus</i>	Glaucous Gull	Probable
Goéland brun	<i>Larus fuscus</i>	Lesser Black-backed Gull	Non-breeding
Goéland marin	<i>Larus marinus</i>	Great Black-backed Gull	Confirmed
Grand Corbeau	<i>Corvus corax</i>	Common Raven	Confirmed
Guillemot à miroir	<i>Cephus grylle</i>	Black Guillemot	Confirmed
Harelde kakawi	<i>Clangula hyemalis</i>	Long-tailed Duck	Confirmed
Harle huppé	<i>Mergus serrator</i>	Red-breasted Merganser	Possible
Junco ardoisé	<i>Junco hyemalis</i>	Dark-eyed Junco	Confirmed
Lagopède alpin	<i>Lagopus muta</i>	Rock Ptarmigan	Confirmed
Merle d'Amérique	<i>Turdus migratorius</i>	American Robin	Confirmed
Oie des neiges	<i>Chen caerulescens</i>	Snow Goose	Possible
Phalarope à bec étroit	<i>Phalaropus lobatus</i>	Red-necked Phalarope	Non-breeding
Pipit d'Amérique	<i>Anthus rubescens</i>	American Pipit	Confirmed
Plectrophane des neiges	<i>Plectrophenax nivalis</i>	Snow Bunting	Confirmed
Plectrophane lapon	<i>Calcarius lapponicus</i>	Lapland Longspur	Confirmed
Plongeon catmarin	<i>Gavia stellata</i>	Red-throated Loon	Confirmed
Plongeon du Pacifique	<i>Gavia pacifica</i>	Pacific Loon	Probable
Plongeon huart	<i>Gavia immer</i>	Common Loon	Possible
Pluvier semipalmé	<i>Charadrius semipalmatus</i>	Semipalmated Plover	Confirmed
Sizerin blanchâtre	<i>Acanthis hornemanni</i>	Hoary Redpoll	Confirmed
Sizerin flammé	<i>Acanthis flammea</i>	Common Redpoll	Confirmed
Traquet motteux	<i>Oenanthe oenanthe</i>	Northern Wheatear	Confirmed

Avian Fauna

Seven species are potentially present in the study zone (Table 6.28). However, only three of them are likely to breed there. Among these three species, only the Peregrine Falcon and the Golden Eagle find their breeding habitat there (cliffs). Breeding of the Peregrine Falcon has also been confirmed by observation of two nests (one containing two nestlings and a second probable nest where two adults were perched). There are no rivers turbulent enough for the Harlequin Duck in the study zone.

Table 6.28 List of special-status bird species likely to frequent the study area

Species	Provincial status	Federal status	
	QATVS ¹	COSEWIC ²	SARA ³
Golden Eagle	Vulnerable	-	-
Harlequin Duck	Vulnerable	Special concern	Special concern
Eskimo Curlew	-	Endangered ⁵	Endangered ⁵
Red Knot Rufa	Likely ⁴	Endangered ⁵	Endangered ⁵
Buff-breasted Sandpiper	-	Special concern	-
Arctic Peregrine Falcon	Likely ⁴	Special concern	Special concern
Ivory Gull	-	Endangered ⁵	Endangered ⁵

¹ QATVS: Quebec Act respecting threatened or vulnerable species

² COSEWIC: Committee on the Status of Endangered Wildlife in Canada

³ SARA: Species at Risk Act

⁴ Likely to be designated threatened or vulnerable

⁵ Endangered

6.3 Human Environment

6.3.1 General

The projected port infrastructures and terrestrial sediment disposal site are located on the southwest shore of Deception Bay. The Village of Salluit is found about fifty kilometres to the west. The Inuit community of Kangigsujuaq, some of whose members are likely to frequent Deception Bay, but to a lesser extent than the Salluit community, is located 170 km to the southeast.

There is no permanent Inuit community as such at Deception Bay. However, the following infrastructures are found there:

- a road running along the west shore of the bay and connecting mining facilities of the Raglan sector to the Xstrata wharf;
- the Xstrata facilities, which mainly include a jetty, a wharf, an ore concentrate hall and a petroleum depot;
- the CRI petroleum depot located near site Q1;

- a temporary workers' camp at Bombardier Beach;
- a permanent Inuit camp at Bombardier Beach;
- a former airfield located in the Deception River estuary.

The Raglan - Deception Bay road is used both to transport ore extracted from the Raglan Mine and to transport merchandise, equipment and petroleum products to the Raglan Mine and the CRI facilities in Raglan-sud. About 15 to 20 concentrate transport trucks drive this road every day.

The next sections present a few sociodemographic traits of the Salluit and Kangiqsujuaq communities.

6.3.2 Sociopolitical and Institutional Frameworks

The administrative structure of Nunavik is the outcome of the JBNQA (signed in 1975), and the Act respecting Northern villages and the Kativik Regional Government. The signing of this Agreement allowed the creation of Makivik Corporation, the landholding corporations, the KSB, and the Nunavik Regional Board of Health and Social Services (NRBHSS) (Gouvernement du Québec, 2012a; Makivik Corporation, 2012). The Act respecting Northern villages and the Kativik Regional Government provided for the creation of the KRG, a supramunicipal entity, and the creation of the Northern villages of Nunavik, while specifying the powers granted to each of these bodies (Gouvernement du Québec, 2012b).

6.3.2.1 Kativik Regional Government

The KRG was created in 1978, following the adoption of the Act respecting Northern villages and the Kativik Regional Government (Kativik Act) and the signing of the JBNQA, for the purpose of providing public services to the Nunavimmiut.

The KRG exercises its powers over all Québec territory located north of the 55th parallel, excluding Category IA and IB lands awarded to the Cree community of Whapmagoostui.

The majority of the KRG's responsibilities are set out in the Kativik Act. The KRG currently offers services in the following sectors:

- administration;
- communications;
- legal services and municipal management;

- employment, training, income support and childcare;
- public security (police and civil protection);
- municipal public works;
- renewable resources, environment and land development;
- research and economic development;
- transportation;
- recreation;
- financial services.

The KRG is responsible for providing technical assistance to the 14 Northern villages, especially in the following fields: legal affairs, management and municipal accounting, town planning and land development, engineering and public transportation.

The KRG's decision-making structure is directed by a Council composed of 17 municipal elected representatives, named by each of the Northern villages and by the Naskapi Nation of Kawawachikamach. The KRG councillors appoint among themselves the five members forming the Executive Committee of the KRG. The Executive Committee is responsible for the administration of the KRG's business and ensures that the decisions of the Council are executed (KRG, 2012 and 2010).

In 2010, the KRG had 10 departments and nearly 400 employees, nearly 62% of whom were Inuit beneficiaries⁸. The head office is located in Kuujuaq, and the employees are divided among the different offices owned by the KRG in each of the 14 Northern villages of Nunavik.

6.3.2.2 Makivik Corporation

Makivik Corporation was created in 1978. This institution is responsible for collecting and managing the compensation money intended for the Inuit, paid under the JBNQA, to ensure compliance with this Agreement and to guarantee its integrity.

In addition of management of the funds granted by the JBNQA, this Corporation has the mandate:

- to relieve poverty, and to promote the welfare, advancement and education of the Inuit;

⁸ The term beneficiary refers to the Aboriginal peoples who benefit from the JBNQA, while non-Aboriginals encompass people who are not included in the JBNQA.

- to foster, promote, protect and assist in preserving the Inuit way of life, values and traditions;
- to exercise the functions vested in it by other Acts or the JBNQA;
- to develop and improve the Inuit communities and improve their means of action (Makivik Corporation, 2012).

In Nunavik, Makivik Corporation is a major partner in social, economic and cultural development. Its fields of activity cover the fields of air transportation, fisheries and caribou marketing, as well as research and development in processing of Northern products.

This Corporation holds several wholly-owned subsidiaries (e.g. First Air, Air Inuit, Nunavik Creations, Nunavik Furs, Halutik Enterprises, Biosciences Nunavut Inc.) and joint ventures (e.g. Cruise North Expeditions, NEAS Inc., UNAAQ Fisheries, Pan Arctic Inuit Logistics).

6.3.2.3 Northern Villages and Municipal Councils

Nunavik includes 14 Northern villages. The villages are several hundred kilometres apart and are located on the shore of Hudson Bay, Hudson Strait and Ungava Bay.

According to the *Kativik Act*, it is incumbent on the 14 Nunavik villages to offer essential public services. Also this Act, the municipal councils of the Northern villages are responsible for management of municipal services and municipal and community administration (Gouvernement du Québec, 2012b).

Municipal services include public security, public health and hygiene, town planning and land development, public services (water supply, lighting, heating, municipal roads, traffic and transportation), recreation and culture. The municipal council of each village is composed of a mayor and councillors, elected or appointed. The mayor is the head of the council and the chief executive of the municipal administration.

6.3.2.4 Landholding Corporations

The landholding corporations arise from the JBNQA. Each Nunavik village has its own landholding corporation, which holds the territory of the village and its immediate vicinity and is responsible for administering the Category I and II lands⁹. Since 2002, the landholding corporations have combined to form the Nunavik Landholding Corporations Association (Nunavik Landholding Corporations Association, 2012).

⁹ The land regime in Nunavik is summarized in paragraph 6.3.5.

6.3.2.5 Kativik School Board

The KSB was created after the signing of the JBNQA to enable the Inuit to take charge of their own education. Its mission is to provide the people of Nunavik with educational services that will guide and enable all learners to develop the qualities, skills and abilities that are necessary to achieve their well-being and self-actualization (KSB, 2012).

The KSB has exclusive jurisdiction in Nunavik regarding preschool, elementary, secondary and adult education. It is also responsible for developing programs and teaching material in Inuktitut, English and French, training the teaching staff in accordance with provincial standards, and promoting, organizing and supervising postsecondary education. The KSB is required to follow the directives of the Ministère de l'Éducation. However, it has the leeway to regulate the teaching of Inuktitut and Inuit culture (KSB, 2012).

In Nunavik, Inuktitut, the mother tongue of the Inuit, is taught starting in kindergarten. Since the 2004-2005 school year, Inuktitut has been instituted in Grade 3 to reinforce learning of the language (GENIVAR, 2007). Thus, half of elementary teaching is in Inuktitut and the other half in the second language. Starting in Grade 4, the classes are taught only in the second language; the parents have the choice of having their children educated in French or in English.

Each village has a school that offers teaching at the elementary and secondary levels. The curriculum is adapted to local needs and emphasizes preservation of culture.

6.3.2.6 NRBHSS and Health Centres

The NRBHSS, based in Kuujuaq, is a stakeholder of the Québec network of agencies and institutions dedicated to public health and welfare (NRBHSS, 2012). It is the Board that manages the supply of health services and social services to the Inuit population.

The Board manages and operates different federal programs and the two main regional health institutions that serve Nunavik, the Ungava Tulattavik Health Centre, located in Kuujuaq, and the Inuulitsivik Health Centre, in Puvirnituq. The Inuulitsivik Health Centre manages the villages located on the coast of Hudson Bay, while the Tulattavik Health Centre manages the villages located on the coast of Ungava Bay. These two centres offer several services to the population, such as common preventive or curative health services and social services, physical rehabilitation services or social reintegration services.

Apart from the Puvirnituq and Kuujuaq Health Centres, points of service reporting to these two Health Centres are located in each of the 14 Nunavik villages. In case of an intervention necessitating specialized care, the patients generally are transferred to one of the Montréal referral hospitals, on a regular flight or by air ambulance.

6.3.2.7 Other Bodies

The Kativik Regional Development Council (KRDC), the Kativik Local Development Centre (KLDC) and the Kativik Municipal Housing Bureau (KMHB) are also part of the Nunavik organizational structure. These bodies offer the Nunavimmiut all the services usually related to the social and economic development of Québec communities.

6.3.3 Agreements

6.3.3.1 Sanarrutik and Sivunirmut Agreements

Several agreements have been made among the Gouvernement du Québec, Makivik Corporation and the KRG since 1998. These agreements have created opportunities for the Inuit to promote their economic and community development (Secrétariat aux affaires autochtones, 2012).

On April 9, 2002, Makivik Corporation, the KRG and the Gouvernement du Québec signed a partnership agreement with the objective “to establish a new nation-to-nation relationship and to put forward a common vision” in order to accelerate the economic and community development of Nunavik (Makivik Corporation, KRG and Gouvernement du Québec, 2008). The Sanarrutik Agreement has a 25-year term; Sanarrutik means “development tool” in Inuktitut. Two years later, on March 31, 2004, the Gouvernement du Québec and the KRG signed the Sivunirmut Agreement on block funding of the KRG; Sivunirmut means “towards the future” in Inuktitut. The purpose of this last agreement is to amalgamate all public funding into a single block funding envelope (Observation by the public administration, 2012).

6.3.3.2 Nunavik Inuit Land Claims Agreement

This Agreement was signed on December 1, 2006 by the Governments of Canada and Nunavut, and by Makivik Corporation (AANDC, 2012). The NILCA concerns the use and ownership of Nunavut’s lands and resources in James Bay, Hudson Bay, Hudson Strait and Ungava Bay, a portion of northern Labrador and a zone off the coast of Labrador.

The region covered by the settlement with the Nunavik Inuit is composed of two sectors:

- the Nunavik Marine Region, which includes the Nunavut offshore islands adjacent to Québec and the intervening waters and lands (including ice);
- the Labrador portion of the Nunavik Inuit Settlement Area, which covers an offshore area adjacent to Labrador, from Killinik Island to just north of Hebron, and an onshore portion in northern Labrador, consistent with the boundaries of the Torngat Mountains National Park Reserve.

Under this Agreement, the Nunavik Inuit henceforth hold 80% of the total areas of the island of the Nunavik Marine Region (which previously belonged to Nunavut), i.e., about 5,100 km², and the land and subsoil rights to this territory. In addition, a fraction of this region, about 400 km², will be shared with the Eeyou Istchee Crees. The lands acquired by the Nunavik Inuit also include all the lands above the ordinary high water mark, as well as the mines and minerals found on these lands or in the subsoil.

The NILCA also provides for the creation of the Nunavik Marine Region Wildlife Board (NMRWB) as an institution of public government. The NMRWB, the first meeting of which was held in March 2009, is thus responsible for management of wildlife resources for the Nunavik Marine Region and regulation of access to resources in the region. Under the NILCA, the Nunavik Inuit have the right to harvest all the wildlife species of the Nunavik Marine Region to satisfy all their economic, social and cultural needs, unless the Council has established a limit consistent with the provisions of the Agreement.

6.3.3.3 Nunavik Nickel Agreement

In April 2008, an Agreement was made among Makivik Corporation, Nunaturlik Landholding Corporation of Kangiqsujaq, Qarqalik Landholding Corporation of Salluit, the Village of Puvirnituk and CRI. This Agreement constitutes a formal commitment on the part of CRI to generate local and regional economic spinoffs resulting from its activities in the region. In addition to Inuit participation in the available jobs and the opportunities for training and contracts, this Agreement guarantees the sharing of royalties with Makivik Corporation and the communities for the duration of the project (Makivik Corporation, 2011).

6.3.4 Sociodemographic Framework

6.3.4.1 Demographic Situation

Population and Age Structure

In 2011, Salluit and Kangiqsujuaq respectively had populations of 1,347 and 696. Between 2006 and 2011, population growth was far greater than for Québec as a whole (respectively 8.5% and 15.0% for Salluit and Kangiqsujuaq, compared to 4.7% for Québec) (Statistics Canada, 2012). Moreover, in these villages, the population is much younger than in the rest of Québec; in 2011, the median age was 21.1 years in Salluit and 22.4 years in Kangiqsujuaq, compared to 41.9 years for Québec as a whole (Table 6.29).

Table 6.29 Sociodemographic data for Salluit and Kangiqsujuaq in comparison with Québec as a whole in 2011 and 2006

Sociodemographic data	Salluit	Kangiqsujuaq	Québec
Area (village) (km ²)	14.39	12.56	1,356,547.02
Area (Inuit land) (km ²)	596.84	572.62	
Population (2011)	1,347	696	7,903,001
Male (2011)	690	340	3,875,860
Female (2011)	660	355	4,027,140
Population (2006)	1,241	605	7,546,131
Population growth in 2006-2011 (%)	8.5	15.0	4.7
Population between ages 0 and 24 years (%) (2011)	57.8	54.3	28.3
Population age 15 years and over (%) (2011)	61.5	67.0	84.1
Median age of the population (2011)	21.1	22.4	41.9
Number of private dwellings (2011)	315	174	3,685,926
Dwellings leased (%) (2006)	99.6	100	39.76
Number of private households (2006)	255	140	3,189,345
One-parent families (%) (2006)	40	36.67	16.31
Mean household size (2006)	4.9	4.3	2.3
Median income of private households in 2005 (2005 constant \$)	67,840	69,888	46,419
Activity rate (%) (2006)	69.9	66.2	64.9
Unemployment rate (%) (2006)	28.0	13.7	7.0

Sources: Statistics Canada, 2012 and 2007.

According to the 2006 census results, Inuktitut is the mother tongue of 93% of the Salluit population and 94% of the Kangiqsujuaq population. English is the most commonly used second language, followed by French (Ancitil, 2008).

Education

According to the 2006 census results, the percentage of the population age 15 and over not holding any university certificate, diploma or degree was 64.3% in Salluit and 64.9% in Kangiqsujaq, compared to 25.0% for Québec as a whole. In the 15-34 age category, only 13.6% of the Salluit population and 8.5% of the Kangiqsujaq population held a Diploma of Secondary Studies or equivalent, compared to 44.7% for Québec as a whole. Finally, in both villages, the 35-64 age category includes the highest proportion of the population who obtained a college or university diploma (Statistics Canada, 2007).

6.3.4.2 Health

Fertility

The Nunavik population growth rate is mainly explained by high fertility. Since 1984, the synthetic fertility index in Nunavik has never been lower than 3.4 children per woman (compared to about 1.4 children per woman for Québec as a whole during the same period) (Duhaime, 2008).

Life Expectancy

Over the past few decades, life expectancy at birth increased in Nunavik up to the 1990-1994 period and then went into regression, while it has been in constant progression in Québec as a whole. For the 2000-2003 period, life expectancy at birth was 16 years lower in Nunavik (63.3 years) than in Québec (79.4 years) (INSP, 2006).

Mortality Rate

Although social and medical services are much improved in Nunavik over the past few decades, this region remains disadvantaged compared to the rest of Québec, in view of the high infant mortality rate recorded in Nunavik relative to the province as a whole (KRG, 1998). According to the Institut de la statistique du Québec (2006), the infant mortality rate for the period from 1999 to 2003 was 16.5% in Nunavik, whereas it was 4.7% in Québec. The mortality rates for people age 0-64 are also higher in Nunavik than in the other regions of Québec (CSF, 2005).

Physical Health Status

In 2004, the NRBHSS initiated a wide-ranging survey of the health of the Nunavik Inuit population. This study, conducted by the Institut national de santé publique (INSPQ), highlighted the main issues related to the health and welfare of this population.

According to the INSPQ study (2004), the Inuit up to now have been well protected against cardiovascular diseases, especially due to nutrition that integrates high consumption of fish and marine mammals (Anctil, 2008). However, the significant increase in risk factors for cardiovascular diseases (glucose intolerance, smoking and obesity) gives reason to anticipate a future increase in problems. The obesity rates observed among the Inuit appear to give ever-greater cause for concern: nearly six out of ten adults were overweight (30%) or obese (28%), and nearly four out of ten persons (37%) had a waistline indicative of an increased risk of health problems, compared to 23% in 1992 (Anctil, 2008).

Regarding sexually transmitted diseases, in 2007, the combined Aboriginal populations of Terres-Cries-de-la-Baie-James and Nunavik reported a chlamydiosis and gonococcal infection rate respectively 12 and 16 times higher than the average rate for the other regions of Québec. In 2007, HIV/AIDS was not detected in any resident of Nunavik (MSSS, 2008).

Nutrition

The Nunavik Inuit consume traditional foods (obtained from hunting, fishing and gathering) an average of five times a week. In 2004, these foods provided them with 16% of their energy intake, compared to 21% in 1992, which represents a net decline in the importance of traditional food (Anctil, 2008). The elders consume more game and marine mammals than the younger generations (Martin, 2003; Roche, 1993).

The Inuit diet, rich in fish and marine mammals, does not only have health benefits, however. Indeed, this diet exposes them to several toxic substances (metals and persistent organic pollutants) bioaccumulated in the Arctic food chain, and brought from the south by ocean and atmospheric currents. Although the blood concentrations observed in the Inuit for metals (cadmium, mercury and lead) decreased significantly between 1992 and 2004, a significant proportion of individuals continue to show concentrations exceeding acceptable levels, according to Health Canada (Anctil, 2008).

Lifestyle

The INSPQ survey showed that the Nunavik Inuit smoked cigarettes more than in the rest of Québec (77% of the Inuit smoke daily or occasionally, compared to 27% elsewhere in Québec), and that 24% of casual drinkers had high alcohol consumption (five or more drinks on the same occasion) at least once a week during

the past year, a percentage three times greater than in the rest of Québec (7.5%) (Anctil, 2008). Finally, 60% of the respondents also affirm that they consumed drugs during the year preceding the survey, a proportion four times greater than the one observed in the rest of Canada (Anctil, 2008).

In 2004, a lower percentage of the Nunavik Inuit population seemed to participate in games of chance than among the rest of the Québec population. Nonetheless, the amounts spent on gambling were much higher among the Inuit than among other Quebecers: 62% of the Inuit declared that they spent more than \$520 on games of chance per year, while this proportion was 9% in the rest of Québec (Anctil, 2008).

Psychosocial Health Status

In 2004, 13% of the Nunavik Inuit population exhibited a high level of psychological distress or were considered likely to develop depression or other mental health problems (Anctil, 2008). This distress appears to be associated with alcohol or drug consumption, as well as a history of sexual violence or exposure to physical violence in a family or conjugal context.

According to the results of the health survey of Nunavik Inuit, conducted in 2004 by the INSPQ, the probability of being a victim of violence is very high in Nunavik: more than half the adults interviewed (54%) reported that they had been subjected to one or more forms of physical violence during their lifetime (Anctil, 2008). Nunavik is also faced with a major problem of sexual violence. In 2004, one in three adults (32%) affirmed they had been victims of sexual assault or attempted sexual assault during childhood or adolescence, and one in five adults (20%) affirmed they had encountered the same problem during adulthood (Anctil, 2008). The Institut national de la santé publique du Québec (2001) also recognized that the suicide rate in the Nunavik region was more than 3.5 times higher than the rate recorded in Québec, and that the suicide rate in Nunavik was more than 6.5 times higher among men than among women (Penney et al., 2009).

6.3.4.3 Housing

Over 90% of the Nunavik housing stock is composed of social housing, which translates into very high percentages of rented dwellings in Salluit and Kangisujuaq, 99.6% and 100%, respectively (Statistics Canada, 2007). Given the climate constraints and the high construction costs, the current real estate market in Nunavik has not been able to meet the growing housing needs of Inuit families, who have

faced a housing crisis for the past few years (KRG and Makivik Corporation, 2011; Dutil, 2010). This situation often obliges several families to live in the same dwelling and explains, in particular, why the average household size is almost double in Salluit (4.9 persons per household) and in Kangiqsujuaq (4.3 persons per household) relative to the rest of Québec (2.3 persons per household) (Statistics Canada, 2007). Multifamily households represent 31% of Nunavik households (a proportion that only reaches 1% in the rest of Québec) (Duhaime, 2008).

6.3.4.4 Transportation

No road connects the communities to each other, or Nunavik to southern Québec. The Nunavik villages thus have a limited road network. Currently, there are only two villages with paved roads, Kuujuaq and Ivujivik. All the other villages have gravel roads. However, the KRG has undertaken, through a subsidy program, to pave several roads in the villages within a few years (KRG, 2009). Outside the villages, there is only a single road, which connects the Port of Deception Bay to the Raglan Mine.

Only air transportation can serve the Nunavik communities year round. In view of the great distances separating the 14 villages, the airplane is often the most efficient means of transportation to travel between villages. Today, all the villages are equipped with airport infrastructures.

Marine transportation is important in Nunavik because it allows heavy or bulky merchandise to be shipped at a more affordable price than air transportation allows. However, marine transportation is possible only between July and October. The lack of adequate marine facilities contributes to increase the cost of marine transportation and results in difficulties of supply for the region (Makivik Corporation, 2012).

Automobiles and pick-ups are used for trips within the villages. Outside the communities, the Nunavimmiut generally travel by snowmobile in winter and by all-terrain vehicle (ATV) or boat in summer. Consequently, a network of very real links exists between the villages and the different areas of practice of subsistence activities (hunting, fishing, trapping and gathering).

Communications

The Nunavik villages are all served by the main telecommunications services, i.e. telephone, radio broadcasting, television broadcasting and the Internet. Each community is equipped with a fixed satellite telephone so that it can communicate with the outside world at any time, regardless of the temperature. A community radio station also broadcasts local and regional programs, mainly in Inuktitut. This radio station represents an essential means of communication in the villages.

6.3.4.5 Economic Context

Economic Sector

Government activities are the leading source of employment in Nunavik. Its economy is strongly influenced by the importance of employment in the public administration sector. According to Duhaime (2004), government activities alone account for more than 50% of the regional domestic product, while government services represent about 7% of the Québec domestic product.

Apart from the government sector, which provides most of the jobs in Nunavik, the region's other sources of economic activity are harvesting of wildlife resources, mineral exploration and mining, construction, retail, transportation and tourism.

Primary Sector

In Nunavik, the primary sector accounts for about 20% of all economic activity, while it represents only 2% of the province's economic activity (Duhaime and Robichaud, 2010). This sector essentially depends on mineral exploration and mining activities and, to a lesser extent, on activities related to harvesting of wildlife and plants.

Hunting, Fishing, Trapping and Gathering

Hunting, fishing, trapping and gathering today play a significant role in Nunavik's economy. Indeed, until the 50s, the Inuit essentially lived off these activities. Today, they still practice them to feed themselves, and sometimes for commercial purposes. Thus, it is estimated that cynegetic activities currently account for about 10% of Nunavik's economy (Martin, 2003). This proportion has decreased significantly since 1969, the year when hunting activities represented about 63.3% of the Inuit population's total income (Martin, 2003).

Secondary Sector

The secondary sector proportionally is much less important in Nunavik than in the rest of Québec. This sector only accounts for 4% of the economy, compared to 27% for Québec as a whole (Duhaime and Robichaud, 2010). This situation is explained by the fact that the manufacturing industry, which nonetheless exists in this Northern region, does not involve a large number of establishments or any large-scale establishments.

In Nunavik, secondary sector jobs are concentrated almost primarily in the construction industry (GENIVAR, 2007a). Since the 1950s, production of art and craft objects by the Inuit, using materials such as ivory, bone, steatite and pelts, is also a monetary income source. To date, however, no data is available to quantify the importance of this activity in Nunavik villages.

Tertiary Sector

Comparable to what is observed in Québec as a whole, the tertiary sector represents more than 70% of all economic activity in Nunavik (Duhaime, 2008). According to Duhaime and Robichaud (2010), this high tertiarization, common to both economies, masks significant structural differences. Thus, the tertiary sector is much less diversified in Nunavik than in the province as a whole. In Québec, public administration occupies nearly 20% of this sector, while other industries, such as services and finance, report an almost comparable size. In Nunavik, the tertiary sector is highly structured by public administration, which alone represents 53% of all regional economic activity, by far exceeding all other activities (retail, services, transportation, tourism).

6.3.4.6 Economically Active Population and Labour Market

The activity rates¹⁰ observed in 2001 and 2006 for the villages of Salluit and Kangiqsujuaq were slightly higher than those recorded in Québec. Between 2001 and 2006, the activity rate rose from 65.9% to 69.9% in Salluit, and fell from 73.4% to 66.2% in Kangiqsujuaq.

During the same period, the employment rate¹¹ remained relatively stable in Salluit, at about 50.5%, while it declined from 60.9% to 55.8% in Kangiqsujuaq. In 2006, the unemployment rate observed in Salluit (28.0%) was more than triple the unemployment rate reported in Québec as a whole (8.0%); in Kangiqsujuaq, this rate was nearly double the provincial rate. Between 2001 and 2006, the unemployment rate¹² increased in Salluit (from 23.5% to 28%), while it decreased in Kangiqsujuaq (from 17.1% to 13.7%).

Between 1993 and 2005, the number of jobs rose from 125 to 203 for the Salluit community, and from 55 to 107 for Kangiqsujuaq. In these two communities, it is observed that the number of full-time jobs nearly doubled. However, it is important to

¹⁰ The activity rate is defined as the percentage of the economically active population relative to the number of persons age 15 years and over.

¹¹ The employment rate is defined as the percentage of the employed population relative to the percentage of the population age 15 years and over.

¹² The unemployment rate is defined as the percentage of the unemployed population relative to the economically active population.

note that most of these jobs are held by non-beneficiaries. Indeed, although they represent less than 10% of the Nunavik population, non-beneficiaries monopolize more than 50% of the region's monetary income (ETISCCD, 2006; Gouvernement du Québec, 2008).

6.3.5 Use of Land and Resources

6.3.5.1 Land and Resource Management and Development

After the signing of the JBNQA, the territory of Nunavik was divided into Category I, II and III lands (AANDC, 2010). Almost the entire study zone (Map 3.1) is located on Category II lands. The Inuit hold exclusive hunting, fishing and trapping rights on these lands. Category II lands are in the public domain, but the Aboriginal decision-making bodies participate in their management concerning these activities and the development of tourism and forestry. The Inuit also have the right to collect steatite, a stone used for sculpture, but do not have exclusive rights to the mineral subsoil. Nonetheless, in the event that a mineral resource is developed, the MRN must give advance notice to the landholding corporation concerned, which is entitled, in this case, to compensation either in the form of an indemnity, replacement of the lands, or a combination of the two (KRG, 1998).

6.3.5.2 Inuit Use of the Territory

Until the early 1950s, the Inuit, a hunter-gatherer people, essentially lived off hunting, fishing and gathering and travelled in small family groups within a regional hunting territory.

The 1950s were the starting point of accelerated changes for the Nunavik Inuit population. The establishment of federal and provincial government services transformed almost every aspect of the Inuit lifestyle: residence, land use, health, education, language and infrastructure, as well as governance and intercommunity relations. During this period, the Inuit people moved from a nomadic lifestyle based on hunting, fishing, gathering and harvesting of wildlife and marine resources, to a mixed economy, both traditional and modern, associated with greater sedentarity and the introduction of wage labour.

Although transformed, the practice of traditional activities, including hunting, trapping and fishing, has remained important in the view of the Inuit communities. Moreover, the practice of these activities has an important identity component (KRG, 1998). These traditional activities have contributed to maintain the vigour of the social

bonds and solidarity of family members and the community. However, economic difficulties and the increasingly high costs of hunting and fishing activities (equipment, petroleum products, etc.) exert considerable pressure on traditional activities and on the relationships of solidarity that accompany them. However, the Inuit were able to adapt some of their practices to these new realities by negotiating the adaptation of certain assistance programs for traditional hunting and fishing activities, the conditions of which were negotiated to correspond better to their reality and their objectives. The adoption of the “community freezer” program and the financial assistance that the sale of community game provides for hunting and fishing activities is an original Inuit solution. It supports both traditional activities and the family and community sharing system that has always been the basis of social organization (Martin, 2003).

Food consumption from hunting and fishing was still important in 2004 and accounted for 16% of the energy intake (versus 21% in 1992). However, this consumption proved to be greater among older Inuit (Anctil, 2008). According to the data collected during this survey, nearly half (45%) of the respondents affirmed that they participate in hunting activities once a week or more, for at least two seasons. A smaller number of persons said that they also participate frequently in fishing activities (33%). Half the population (nearly 48%) affirmed that they participate in picking berries at least once a month when they are in season.

Deception Bay Essential Subsistence Area

Deception Bay is located in the northeast portion of the hunting and fishing sector of the Village of Salluit (Kativik Environmental Quality Commission, [KEQC] 2008). According to the KRG Master Plan for Land Use (1998), it is considered an essential subsistence area for the Salluit community (Map 6.5). The KRG Master Plan specifies that these areas are “pantries” for the communities, to some extent, because hunting, trapping and fishing are practiced there by the majority of the population for subsistence purposes, year round, on a seasonal basis. These essential areas consist of very biologically productive habitats, such as spawning grounds, caribou calving areas, breeding areas or migration corridors, and are indispensable for maintenance of wildlife species. These areas generally contain temporary or permanent campsites, sectors of ecological and esthetic interest, and several known archeological sites.

Frequented of the Deception Bay Sector

The Inuit schemes for use of the territory are partially determined by proximity and travel time. Consequently, Category I lands are generally used on a daily basis by the Inuit, in view of their immediate proximity to the villages. Since Category II lands are more distant, they are frequented more occasionally. Often, temporary camps used on a seasonal basis are found there.

The studies conducted by GENIVAR (2007a and 2007b, 2011) show that Deception Bay is still an environment prized by the Inuit of the region, mostly those of Salluit. It is frequented mainly for fishing, seal and beluga hunting, and gathering Blue Mussels. Given its easy access by watercourses and its proximity, Deception Bay may also be frequented by people from Kangiqsujuaq, but it seems that this is more occasional.

Camps and Movement Axes

In the early 1990s (Roche and Canartic, 1993 in GENIVAR, 2007a), a camp had been inventoried on a west shore of Deception Bay, south of the future CRI port facilities. Two other campsites had also been located on the east shore of Deception Bay and north of Lac Duquet. A few preferred trails allowing access to and circulation on the bay had also been identified, as well as seal hunting areas. They were still used in 2007 (Don Cameron, Nuvumiut Developments Inc., pers. comm. in GENIVAR, 2007b) (Map 6.6).

The permanent Inuit camp is still in place and is occupied on a seasonal basis by about twenty people (É. Normandeau, GENIVAR, pers. comm., 2012) (Map 6.6). Another fishing camp is located on the east shore, not far from the mouth of the bay. The Inuit also frequent a fishing area located between Lac Duquet and the Deception River. The campsite located during the 1990s north of Lac Duquet is still in place and is used mainly for fishing activities.

Traditional Hunting and Fishing

No precise statistics or up-to-date (or historical) data exist that could allow a complete profile of the hunted species or the harvested volumes.

In general, the communities harvest up to four wildlife groups: marine mammals, land mammals, birds and fish (Table 6.30).

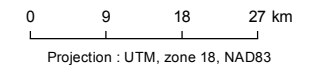

Sources :
 Base : BDGA, 1 : 250 000, MRNF Québec, 2002
 Données-cadres 1 : 1 000 000 / National Scale Frameworks, RNCAN
 Administration régionale Kativik, 1998. Plan directeur d'aménagement des terres
 de la région de Kativik. Les grandes orientations d'aménagement et les affectations
 du territoire. Service de l'environnement et de l'aménagement du territoire. 67 p.
 (www.geoportal.krg.ca) Page consultée / Page consulted



Inventaires et cartographie / Surveys and mapping : GENIVAR
 Fichier / File : 101_53046_EIES_BD_c6_5_util_terr_121120.mxd

Novembre / November 2012

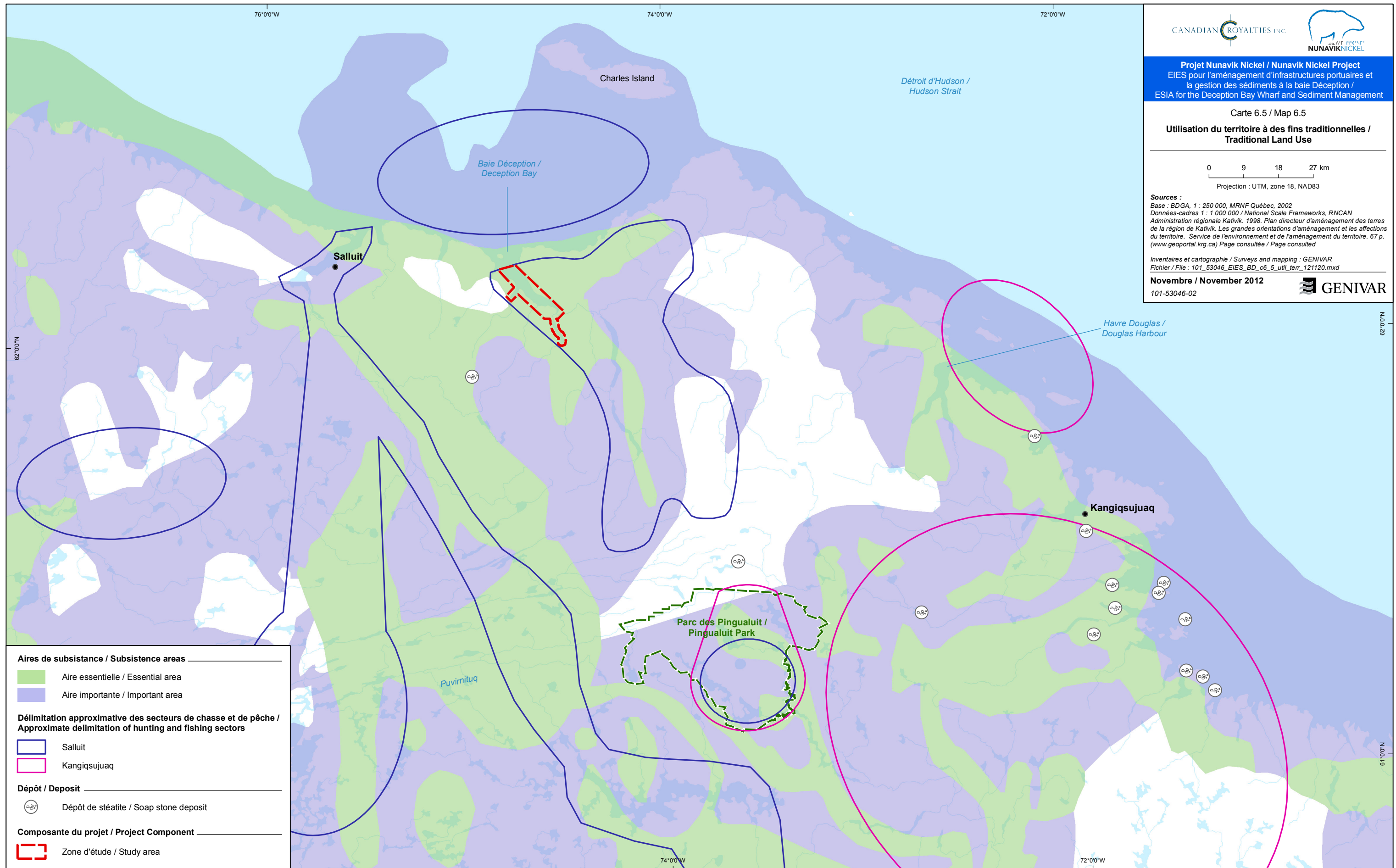
101-53046-02



Aires de subsistance / Subsistence areas

-  Aire essentielle / Essential area
-  Aire importante / Important area

**Délimitation approximative des secteurs de chasse et de pêche /
 Approximate delimitation of hunting and fishing sectors**

-  Salluit
-  Kangiqsujuaq

Dépôt / Deposit

-  Dépôt de stéatite / Soap stone deposit

Composante du projet / Project Component

-  Zone d'étude / Study area

Table 6.30 List of the main wildlife species harvested by the Salluit and Kangiqsujaq communities (Thiffault 2007, GENIVAR, 2007 and 2007b).

Fish and halieutic resources
<ul style="list-style-type: none"> • Arctic Char • Brook Trout • Fourhorn Sculpin • Touladi (Lake Trout) • Icelandic Scallop • Blue Mussel
Marine mammals
<ul style="list-style-type: none"> • Harp Seal • Ringed Seal • Bearded Seal • Harbour Seal • Beluga • Polar Bear
Birds
<ul style="list-style-type: none"> • Snow Goose • Canada Goose • Common Eider • Black Guillemot • Rock Ptarmigan
Land mammals
<ul style="list-style-type: none"> • Caribou • Fox • Wolf

Beluga

The Salluit and Kangiqsujaq populations traditionally hunt Belugas belonging to the eastern Hudson Bay and Ungava Bay populations. This hunting occurs mainly in the spring and fall, when the Belugas enter or leave Hudson Strait. For 2012, the Nunavik Marine Region Wildlife Board (NMRWB) set the hunting quota for this marine mammal at 105 individuals for the four Hudson Strait communities (Quaqtaq, Kangiqsujaq, Salluit and Ivujivik).

DFO researchers compiled data on Beluga capture by the Inuit of Salluit from the years 2005 to 2008, but this data does not specify the capture sites. It shows 23 Belugas captured in 2005, 19 in 2006, 33 in 2007 and 8 in 2008.

Seals

The consultations conducted in 2006 for the NNiP indicated that Deception Bay is a preferred sector for seal hunting (GENIVAR, 2007a). The main species hunted is the Ringed Seal, which is the most important marine mammal by far in food and economic terms for the Inuit of Salluit (GENIVAR, 2007 – RS navigation). In addition to Ringed Seals, Harp Seals, Bearded Seals and sometimes Harbour Seals are captured in small numbers by the Inuit (GENIVAR, 2007a). The main ice hunting sectors are located near the mouth of the bay and were still used in 2007 (Don Cameron, Nuvumiut Developments Inc., pers. comm. in GENIVAR, 2007b). These sectors are illustrated in Map 6.6.

Bowhead Whale

The Bowhead Whale is the object of large-scale subsistence hunting, but no information allows us to specify whether this happens in Deception Bay.

Fish and Molluscs

The Arctic Char, the anadromous Brook Trout and the Fourhorn Sculpin are the main fish species harvested in Deception Bay. The Inuit also harvest the Blue Mussel in the intertidal zone. However, the available data does not allow us to localize the harvested zones or specify the size of the harvests. This gathering mainly happens in winter when these molluscs reach their maximum size.

Picking Berries and Plants

During the consultations conducted in 2006 (GENIVAR, 2007a), it was reported that people from Salluit picked berries on the shores of Deception Bay. The main species picked in summer and early fall were blackberries, cranberries, cloudberry and blueberries. In general, the traditional picking activities occur near communities or camps.

6.3.6 Archeological Potential

Within the context of the NNiP, the Deception Bay sector was prospected to identify the archeological potential of the different sites studied for the variants and the construction sites. The sector report prepared by Artefactuel presents the prospecting campaigns conducted in the summer of 2012 (Appendix 15).

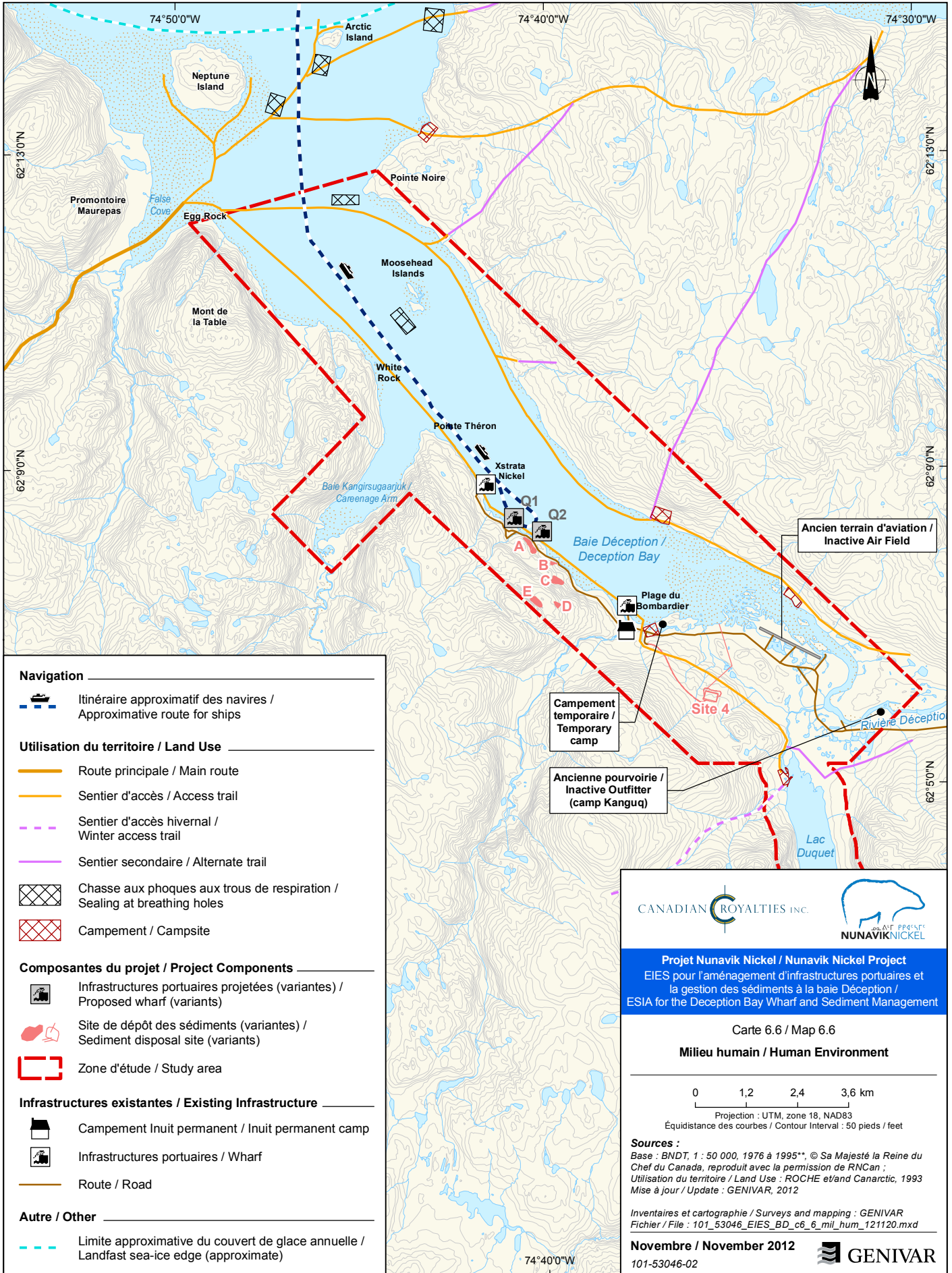

These prospecting operations, in particular, covered the site of the petroleum depot, the archeological site designated as Ka-Fi-1, which was assessed in the summer of 2008. Following this assessment, an Artefactuel team conducted inventories of five tent circles and five secondary structures in two separate areas. The surveys conducted in the first area exposed very little archeological material. It does not present any interesting archeological or scientific potential (Artefactuel, 2008). The surveys conducted in the second area exposed archeological material that allowed two times of occupancy to be identified, dating from at least the Dorset period to the recent or contemporary historical period.

In August 2012, a prospecting campaign conducted by Artefactuel covered the entire site of terrestrial sediment disposal site 4, as well as the projected access road and diversion channel (Map 1; Artefactuel, 2012). Sectors peripheral to the places targeted by the work that seemed promising were also prospected. This field campaign also made it possible to prospect a series of plateaus on the north slope of the hill where the variants of terrestrial sediment disposal sites C, D and E are located. No archeological site was exposed during prospecting of these sites.

6.3.7 Landscape

A visual environment integration study was conducted and is presented in Appendix 16. This study includes a description of the landscape of the study zone, a delimitation of the landscape units, a visual analysis, visual simulations of the projected wharf and terrestrial sediment disposal site, and an assessment of the visual impacts of these developments

The landscape units of the study zone are:

- bay and water body;
- archeological site;
- road surface;
- industrial sector;
- hill;
- anthropogenic environment and camps;
- valley;
- island;
- plain.

Table 1 of the integration study (Appendix 16) presents a description of each of these units.

Two portions of the study zone are part of the industrial sector unit. The first is located at Bombardier Beach, where the CRI temporary camp is found, in particular. The second extends on both sides of the road located on the south side of Deception Bay, from the CRI petroleum depot to the Xstrata facilities. The wharf and the terrestrial sediment disposal site will be inserted in this second portion.

7. PROJECT DESCRIPTION

The volume of sediment to be dredged for the wharf construction at Deception Bay has raised many questions and comments from the majority of people involved in the project analysis, since the landslide at the Q1 site in 2010. In order to minimize dredging and other environmental issues related to the development of wharf infrastructures, CRI has conducted a comprehensive review of the concept. This revision main objective was to find a solution to build a wharf that can withstand ice movement by minimizing the volume of sediment to dredge and the structures footprint.

This section describes the structures and the project activities, as well as the work related to their construction, operation and maintenance. These structures and activities are:

- permanent and temporary wharf;
- ore transshipment;
- navigation required for transportation ore as well as the supply of goods and materials;
- disposal site in terrestrial environment of the dredged sediment;
- transportation of dredged sediment to the land disposal site.

This section also presents the proposed construction methods, the schedule, dimensions and areas of various structures as well as plans.

Map 7.1 shows the general layout of the project.

7.1 Wharf infrastructures

7.1.1 Location

Wharf infrastructures will be built at the site Q1, as authorized in the global certificate of authorization issued in May 2008. The central geographical coordinates at Q1 are:

- 62°08'20" North latitude
- 74°40'49" West longitude

The UTM coordinates (NAD 83 datum, Zone 18 N) of the same area, are as follow:

- X = 516661 mE
- Y = 6889720 mN

7.1.2 Permanent wharf

The proposed concept consists in building a floating wharf including the following structures (Map 7.2):

- two circular cells (cell 1 - north and cell 2 - south) consisting of sheet piles filled with crushed stone;
- two riprap to protect these cells;
- a bridge maintained on piles and equipped with an access ramp;
- a floating barge docked to the shore and to the cells by means of cables;
- an abutment on the shore outside of the limit of higher high water large tide (HHWLT)

For each cells, the layer of clay sediment will be previously excavated (plans 506117-7000-41-DK-0003 and 506117-7000-41-DK-0004; Appendix 17.1). A volume of approximately 43,000 m³ will be dredged until the silty sand layer is reached. The working method is described in section 7.1.5.

A template will be used for their installation. It will be slid over eight piles previously driven at specific locations uniformly distributed on the inner periphery of the template. The sheet piles making up the cell walls will be therefore attached to the template, which will be left in place within the filling of crushed stone. The base of the cells of sheet piles will be anchored in the unexcavated layer of silty sand. The sheet piles will be pushed into the ground by vibration.

The interior of the cells will be filled with rocks of diameter varying between 100 and 300 mm. These rocks will come from excavated rock produced in summer 2011 for the development of the storage hall and stacked temporarily near the oil depot.



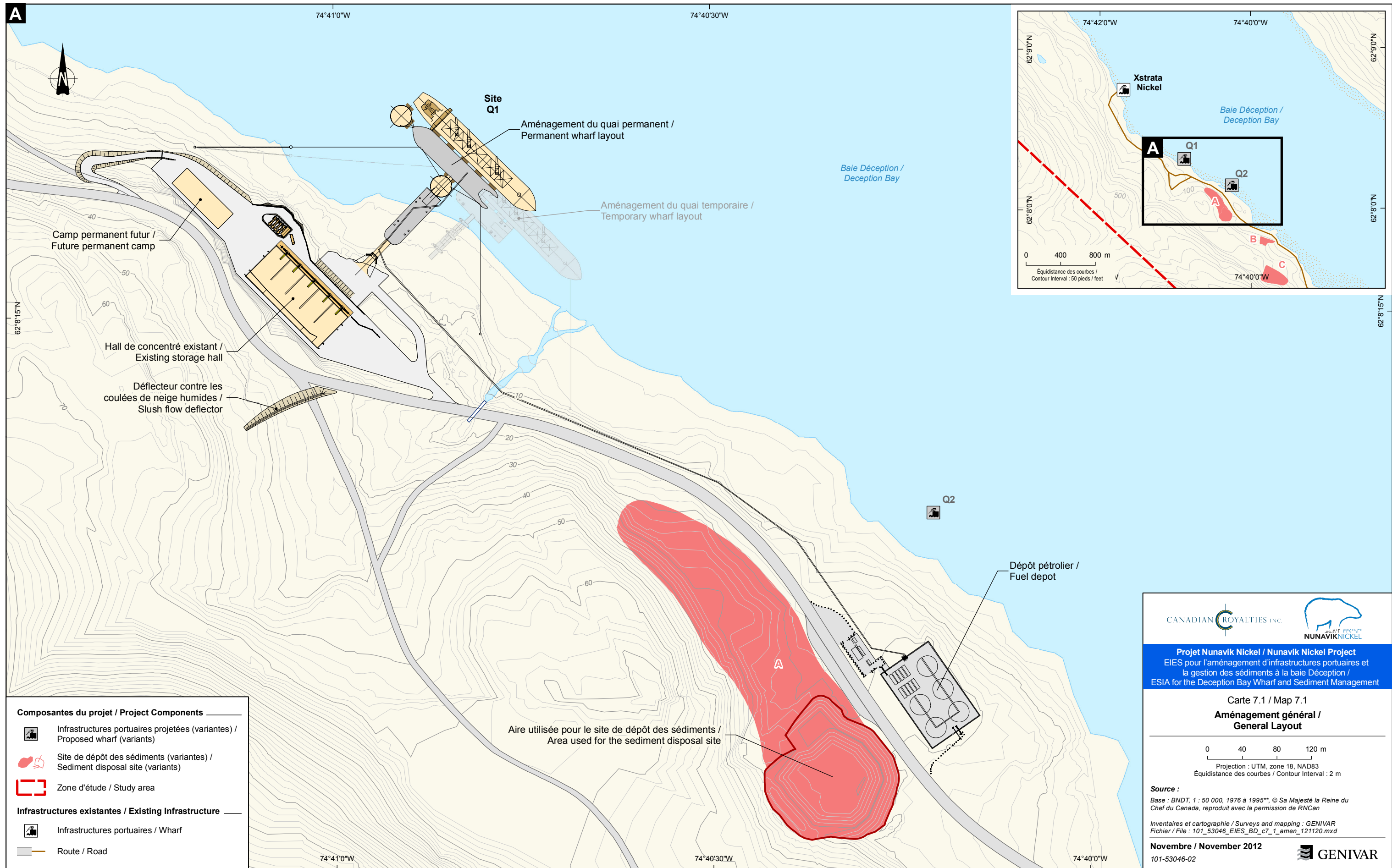

Each cell will be equipped with a concrete slab at its surface. In order to increase the stability of the structures exposed to ices movement, rock backfill will be disposed around each of the cells sheet piles (plans 506117-7000-41-DK-0005 and 506117-7000-41-DK-0006; Appendix 17.2).

The cells will include an icebreaking system on their face, ship side. This system is based on the heating of the cell walls via heated steel rods placed in the concrete. Thus, when the system is operating, ice will not adhere to the cell wall.

In order to weaken the ice near the sheet piles cells, an air bubble system could also be implemented. The principle is to install a system generating bubbles directly at the bottom, around structures to protect. As they rise, the bubbles carry water from



Composantes du projet / Project Components

-  Infrastructures portuaires projetées (variantes) / Proposed wharf (variants)
-  Site de dépôt des sédiments (variantes) / Sediment disposal site (variants)
-  Zone d'étude / Study area
- Infrastructures existantes / Existing Infrastructure**
-  Infrastructures portuaires / Wharf
-  Route / Road



Projet Nunavik Nickel / Nunavik Nickel Project
 EIES pour l'aménagement d'infrastructures portuaires et la gestion des sédiments à la baie Déception / ESIA for the Deception Bay Wharf and Sediment Management

Carte 7.1 / Map 7.1
Aménagement général / General Layout

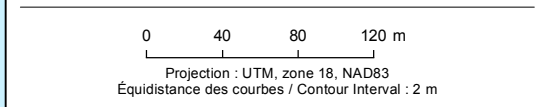

Source :
 Base : BNDT, 1 : 50 000, 1976 à 1995**, © Sa Majesté la Reine du Chef du Canada, reproduit avec la permission de RNCAN
 Inventaires et cartographie / Surveys and mapping : GENIVAR
 Fichier / File : 101_53046_EIES_BD_c7_1_amen_121120.mxd

Novembre / November 2012
 101-53046-02 



A

74°41'15"W 74°41'0"W 74°40'45"W

Baie Déception / Deception Bay

Ancrage au sol / Shore anchor

Amarre chaîne / Stud link chain

Amarre cordage / Mooring softline

Cellule no. 1 / Sheet pile cell no. 1

Site Q1

Système de défenses / Fendering system

Barge

Cellule no. 2 / Sheet pile cell no. 2

Pont-barge / Bridge-barge

Réservoir diésel / Diesel tank

Rampe d'accès / Access ramp

Culée / Abutment

Ancrage au sol / Shore anchor

Ponceau / Culvert

Aménagement du quai temporaire / Temporary wharf layout

Camp permanent futur / Future permanent camp





Groupe électrogène / Generator

Appentis / Shed



Hall de concentré existant / Existing storage hall

Défecteur contre les coulées de neige humides / Slush flow deflector

Composantes du projet / Project Components

-  Infrastructures portuaires projetées (variantes) / Proposed wharf (variants)
-  Trajet des camions / Trucks path
-  Site de dépôt des sédiments (variantes) / Sediment disposal site (variants)
-  Zone d'étude / Study area

Infrastructures existantes / Existing Infrastructure

-  Infrastructures portuaires / Wharf
-  Route / Road



Projet Nunavik Nickel / Nunavik Nickel Project
 EIES pour l'aménagement d'infrastructures portuaires et la gestion des sédiments à la baie Déception /
 ESIA for the Deception Bay Wharf and Sediment Management

Carte 7.2 / Map 7.2
Concept d'aménagement du quai permanent / Permanent Wharf Layout Concept

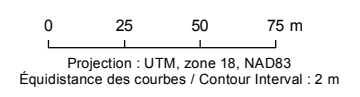

Source :
 Base : BNDT, 1 : 50 000, 1976 à 1995**, © Sa Majesté la Reine du Chef du Canada, reproduit avec la permission de RNCAN
 Inventaires et cartographie / Surveys and mapping : GENIVAR
 Fichier / File : 101_53046_EIES_BD_c7_2_quai_perm_121120.mxd

Novembre / November 2012
 101-53046-02 

the bottom (usually warmer) to the surface, limiting the formation of thick ice. Given arctic conditions in Deception Bay, it is possible that a thin layer of ice will form on top of the water (or slightly above by water vapor condensation which freezes), but the system will still weaken the ice and prevent damage to the structure. If this technique is chosen, the compressors would be installed on the shore, in insulated containers.

The bubble system, like the activation of the propellers when the vessels are moving, may cause the resuspending of sediment. The physico-chemical analysis performed on the sediment since 2006 showed that the sediment at the Q1 site is not contaminated with heavy metals or hydrocarbons. In addition, no asbestos was detected in the sediment. In light of these results, sediment resuspension would not lead to a temporary increase in turbidity and will not contaminate the water in the bay.

Before proceeding to the riprap around cell 2 (south), four permanent piles having a diameter of 1.2 m with 254-mm thick walls will be driven down to rock. Concrete will then be applied to the entire interior. These piles will be used to maintain the bridge which will link cell 2 to the shore, 2 m above the HHWLT limit. The two pillars located near cell 2 will be in riprap while the other two located on the shore side will be drilled into the material in place. Riprap will be built around these between the natural ground surface up to an elevation of 5.6 m which is, the elevation of HHWLT. This structure will be able to push back ice during winter.

The bridge, built of steel, will measure approximately 76 m long and 22 m wide. It will have a height of 4.6 m, including a guard with a minimum height of 1 m. The bridge consists of a barge equipped with a jackup system. This system is composed of four anchor piles (spud leg) with a diameter of 1.37 m. Each anchor pile is equipped with a hydraulic power unit.

The barge bridge will float into position and will be hoisted with the hydraulic system to the required elevation, approximately 2 m above the limit of HHWLT, and fixed to the four pillars. Once the bridge will be fixed, the hydraulic systems, including the four anchor piles, will be removed. The bridge will be connected to the shore and to cell 2 with steel ramps of a capacity of 85 Mt. On shore, an abutment made of concrete backfill with rock will be built outside the HHWLT limit.

The 20 m long and 5.5 m wide ramp will be fixed to the bridge and will rest on the abutment and its backfill. On the side of cell 2, a first steel ramp will provide access to the cell. A second 20 m length steel ramp will provide access to the barge. This ramp will be attached to the barge by means of hinges in a manner to allow movement depending on tides, while the base will slide on the surface of cell 2.

As shown on the general development plan, ships will be docking in a barge. This barge, very massive, is designed according to Lloyds of the icebreakers ships which can withstand ices forces and take waves. The dimensions of the barge will be approximately 150 m x 25 m. It will be held in place by means of mooring cables attached to the bollards located on the sheet piles cells, as well as the shore (plan 506117-7000-41-DK-0007; Appendix 17.3). It will serve as floating dock, the bow will be in the direction of cell 1, while cell 2 will be on the port side of the barge. Stationary defense systems made of rubber or flexible polyvinyl chloride (PVC) cells will be installed at the contact points. Ships will dock to the starboard side of the barge, which will be equipped with approximately six air defenses of 3.3 m diameter and 10.6 m long. Pneumatic floating defenses are a proven alternative to the stationary defenses and are primarily used in the event of boat to boat docking for transshipment at sea or in ports with high tides.

According to this concept, the proposed wharf can significantly reduce the footprint of the port infrastructure, as well as the required dredged volume. Table 7.1 shows the comparison of the different concepts studied since 2008.

Table 7.1 Comparison of the different wharf concepts

Concept	Date	Footprint	Dredged volume
Q1 site	2008	12,118 m ²	35,000 m ³
Q2 site	December 2011	52,200 m ²	250,000 m ³
Q2 revised site	May 2012	19,300 m ²	55,000 m ³
Q1 revised site	October 2012	9,350 m ²	43,000 m ³







7.1.3 Temporary wharf

To allow the loading of vessels with the copper and nickel concentrates stored in the storage hall during winter 2013, a temporary wharf will be built in July 2013 (Map 7.3).

Although this structure will not be in use until summer 2013, it will allow a safe loading of the ore before the construction of the permanent wharf is completed. The temporary wharf is designed to be quickly installed and quickly dismantled. It is estimated that a seven-day period is required for its deployment. This temporary wharf could not withstand the rigors of the Arctic winter, but will be very stable and reliable during the summer season.

The proposed design for the floating dock includes a temporary barge and a bridge held out of the water by means of six anchoring piles equipped with a hydraulic lift system. The barge will be held in place using these piles. Access to the bridge will



- Composantes du projet / Project Components**
-  Infrastructures portuaires projetées (variantes) / Proposed wharf (variants)
 -  Trajet des camions / Trucks path
 -  Site de dépôt des sédiments (variantes) / Sediment disposal site (variants)
 -  Zone d'étude / Study area
- Infrastructures existantes / Existing Infrastructure**
-  Infrastructures portuaires / Wharf
 -  Route / Road

CANADIAN ROYALTIES INC. 

Projet Nunavik Nickel / Nunavik Nickel Project
 EIES pour l'aménagement d'infrastructures portuaires et la gestion des sédiments à la baie Déception /
 ESIA for the Deception Bay Wharf and Sediment Management

Carte 7.3 / Map 7.3
**Concept d'aménagement du quai temporaire /
 Temporary Wharf Layout Concept**

0 25 50 75 m
 Projection : UTM, zone 18, NAD83
 Équidistance des courbes / Contour Interval : 2 m

Source :
 Base : BNDT, 1 : 50 000, 1976 à 1995**, © Sa Majesté la Reine du
 Chef du Canada, reproduit avec la permission de RNCAN

Inventaires et cartographie / Surveys and mapping : GENIVAR
 Fichier / File : 101_53046_EIES_BD_c7_3_quai_temp_121120.mxd

Novembre / November 2012
 101-53046-02 

be provided by two ramps arranged at each end of the bridge. Plans 533079-8301-0001 and 0002 (Appendix 17.4) illustrate in plan and section the structures composing the temporary wharf.

The barge used as a temporary wharf will serve as the bridge in the permanent wharf concept, thus the dimensions are identical. During periods of strong winds, the barge will be raised above the water level with the hydraulic automatic lift. The four anchor piles will be driven to bedrock. Unlike the barge in the permanent wharf concept, the barge is not designed to withstand waves and ice. Under heavy wind conditions, it is more advantageous and safe to use the automatic lift system to hoist the barge above the waves than moving it offshore to avoid breakage risk.

The temporary bridge will be constructed of steel and will have a total length of approximately 45.7 m, a width of 12.2 m and a height of 2.1 m (plans 533079-8301-0001 and 0002, appendix 17.4). It will consist of an assemblage of the following units:

- 9 units of 12.2 m x 3 m x 2.1 m;
- 6 units of 6.1 m x 3 m x 2.1 m.

The temporary bridge will also be equipped with an automatic lift system. This system is composed of six hollow anchoring piles with a diameter of 0.97 m and with three hydraulic power units for hoisting the structure to the required elevation, 2 m above the HHWLT limit. All piles will be driven to bedrock. The barge-bridge will float to its position and will be raised with the hydraulic system.

Two steel ramps with a capacity of 85 Mt and of approximately 12.5 m long by 5.5 m wide will connect the shore to the bridge, and the bridge to the barge. The ramp connecting the bridge to the barge will be mobile in order to follow vertical displacement of the dock.

7.1.4 Piles driving

As mentioned in section 7.1.2, the construction of sheet piles cells, the set up and maintenance of the barge bridge will require piles driving. The piles will be set up in place by vibrodriving in the surficial materials and hammered in the rock section.

It is estimated that the construction of the two sheet piles cells by means of templates will require eight piles per cell. These piles will be driven into the rock to a depth of approximately 2 m. The rock will then be fractionated by the interior of the pile.

For the permanent bridge, a total of eight piles will be drilled; four piles will serve as pillars and four anchor piles will be used to raise the barge to the required elevation.

The temporary wharf requires six anchoring piles for the maintenance of the bridge above the water and four other to lift the barge above water during storm conditions.

7.1.5 Dredging

7.1.5.1 Description of the work

Prior to the set-up of the sheet piles cells, the clay sediment layer will be dredged. The installation of cell 1 (north) requires the dredging of approximately 23,000 m³, while for cell 2 (south) a dredged volume of approximately 20,000 m³ is estimated. Thus, a total volume of approximately 43,000 m³ will be dredged. Spreadsheets used to determine the dredged volumes are in Appendix 18.

In the tidal zone, dredging will be carried out using an excavator. Excavated sediment will be deposited directly into the bin of an off-road truck and will be transported to the sediment disposal site. Transportation is described in section 7.3.1.

As for the work in open waters, dredging will be carried out using a clamshell dredge. The clamshell dredge has a capacity of 10 m³. Sediment will be deposited at first on another barge. Once the barge is full, it will be moved by a tug until it is leaning against the shore or against a small working platform built on the shore. An excavator will then transfer sediment into trucks.

It is expected that sediment dredging will be carried out over a period of approximately 16 hours per day. It is possible to dredge approximately 100 m³/hour, if weather conditions allow it. An estimated volume of 43,000 m³ has to be excavated, a little less than 30 days would be required for dredging.

The work would be carried out from mid-June to mid-July 2013, and considering that the mitigation measures described in the environmental impact assessment form (section 8) will be strictly enforced.

7.1.5.2 Sediment dispersion

Modeling of the sediment dispersion plume was conducted to predict the impacts of dredging on the water quality in Deception Bay. The results of these simulations are presented in the hydrodynamics modeling of Deception Bay sector report (Appendix 7). The following paragraphs are taken from this report.

First, considering only the tide effect, the simulations indicate that after 25 days of dredging, suspended solids (SS) concentrations near the work area and on the opposite shore could reach values higher than 100 mg/L or even 300 mg/L. However, at the center of the bay, simulations suggest concentrations ranging between 3 and 30 mg/L, which meets the surface water quality criterion for aquatic life protection set by the MDDEP (2012), this is 25 mg/L over the natural concentration observed which is 5 mg/L. This phenomenon is explained by low flow rates in Deception Bay, and by the fact that this flow is reversed to the tide.

Simulations were also performed to account for currents induced by wind and tide. The simulations were initially performed for south-west winds, and then for north-west winds (prevailing winds in Deception Bay during the construction period). In both cases, the simulations were performed considering sustained winds of 30 km/h over a period of 1.5 to 3 days.

The results show a significant effect of wind on the sediment dispersion. Indeed, winds generate unidirectional currents much larger than the weak oscillatory currents associated with tides only, which tend to spread the sediment plume in directions more defined. A wind from the north-west carries the dispersion plume toward the Bombardier Beach and to the Deception River mouth, while a wind from the south-west sends the plume towards the mouth of the bay (Figure 29, Appendix 7).

Given the different assumptions adopted for the realization of these models, the results should be interpreted with caution and discernment. Nevertheless, they provide a better understanding of the expected progression of the sediment plume. It appears that it is strongly influenced by the direction and strength of wind, tidal influence being minor.

It is impossible to predict the weather conditions at the moment of the work. However, considering that the wind forces could vary between 17.6 and 27.3 km/h approximately 50% of the time at Deception Bay during the construction period (section 6.1.3.2), the strict application of all mitigation measures during dredging should limit the resuspension of sediment and their dispersion in Deception Bay.

These measures are presented in the environmental impact assessment forms (section 8).

Finally, the use of a sediment curtain or a bubbles curtain was considered to confine the suspended sediment and limit their dispersion in Deception Bay. However, the effectiveness of these methods is greatly reduced in an environment where tides are higher than 3 m and where wind events are important, which is the case in Deception Bay (Bray, RN – Editor, 2008). Thus, it was decided not to use such methods of containment.

7.1.6 Riprap

Excavated material outside the sheet piles cells will be replaced by riprap. The cells top will be equipped with a concrete slab and the wall heating system will be embedded in concrete. The residual volume inside these cells will be filled with rocks.

Riprap will be placed around both pillars of permanent wharf located near the shore in order to ensure protection against ice.

The abutment built on the shore will consists of concrete and riprap.

Table 7.2 presents the estimated volumes of riprap required and the structures areas.

Table 7.2 Estimated volumes of riprap and structures areas

Location	Volume (m ³)	Area (m ²)
Cell 1 (north)		
• interior	8,900	470
• exterior	23,000	4,430
Cell 2 (south)		
• interior	8,200	470
• exterior	19,500	3,800
Abutment	400	270
Pillars	500	160
Total	60,500	9,600

Geochemical tests were carried out on the rocks which will be used and stored on the future sediment disposal site. The results show that these are not acid generating. Certificates of analysis are available in Appendix 19.

7.1.7 Maintenance

Besides a visual inspection of the structures put in place, the concept of the proposed wharf requires no maintenance. As shown by the hydrodynamic modeling (GENIVAR, 2012a), the development of wharf has little influence on the current measurements due to its configuration which allows free passage of water along the shore. This configuration also helps maintain the litoral drift of the sediment transported by the currents induced by waves (sediment load transient along the shore), which should result in little or no additional accumulation of sediment near the wharf. Maintenance dredging is thus not anticipated.

7.1.8 Geotechnical considerations

Stantec was selected to assess the overall stability of the wharf concept built by means of sheet pile cells.

Stability of both cells was analyzed under two scenarios:

- no dredging and sheet piles cells supported by driven piles to bedrock;
- dredging the silty clay layer at the cells location and setting up riprap.

For these two scenarios, a stability analysis was performed considering, firstly, the ice pressure in order to assess the risk of slipping towards the shore and, thereafter, without the strength of ice to verify potential sliding seawards. All stability analyzes were performed using the software SLOPE / W developed by the company GEO-SLOPE International.

For all analyzes, the safety factor of several surfaces with rupture potential was calculated in order to determine the minimum safety factor. The safety factor is defined as the ratio of the stabilizing forces in relation to the driving forces tending to cause rupture. Safety factors obtained for the eight simulations are presented in Table 7.3.

Table 7.3 Summary of safety factors

Cell	Dredging	Ice load	Expected sliding direction	Safety factor
Cell 1 (north)	Yes	0	Seawards	2.12
	Yes	275 kN/m	Toward the shore	9.36
	No	0	Seawards	2.46
	No	275 kN/m	Toward the shore	>100
Cell 2 (south)	Yes	0	Seawards	1.83
	Yes	1940 kN/m	Toward the shore	2.25
	No	0	Seawards	1.91
	No	1940 kN/m	Toward the shore	3.91

In all cases, safety factors obtained are higher than 1.5, which is acceptable.

It is important to note that for the dredging scenarios, it was assumed that the excavation at cells location will be stable on a slope of 3H:1V.

The safety factor against tipping under the action of ice loads applied was also examined. For cell 1, the safety factor against toppling is approximately 10 for both options (with and without dredging). For cell 2, which is subjected to higher ice loads, the safety factor against toppling is 1.9 for both options. This is also considered acceptable.

The risks that a slide occurs during the development of the wharf are minimized due to a better knowledge of the environment and a more favorable cells positioning made possible due to their small numbers.

7.2 Transshipment of ore

The first conveyor (conveyor No. 1) is installed in a shed, in a building section constructed below the storage hall, and then directed to a second conveyor (conveyor No. 2), by which the concentrate will be forwarded to the ship loader (Figure 7.1).

Conveyor No. 2 will be located in a tubular conduit, half of the section will be used for the conveyor and the other half will include an access platform. Each conveyor possesses a nominal capacity of 500 t/h. At the end of conveyor No. 2, the concentrate will be confined in a completely closed telescopic vertical drop which will descend to the floating wharf height (Figure 7.2).

The ship loader is a third conveyor, but with variable geometry to accommodate different sizes of ships and tides. This conveyor installed on the floating wharf will also be completely closed.

At the end of the third conveyor, the concentrate will be confined to a telescopic vertical drop which will descend to the boat deck height (Figure 7.2). The loader arm will pivot vertically and horizontally to effectively reach the holds of the ship and minimize the effects of free falling materials.

It is important to note that although the concentrate is damp and that risks of dust generation are minimal, dust collectors will be installed at all transfer points between conveyor sections (Figures 7.2 and 7.3).

The preventive measures in place, such as the development of conveyors in closed structures, maintaining the concentrate to a moisture content of 6-8%, and the implementation of dust collectors will minimize the risk dispersion of dust into the atmosphere.

In the summer of 2013, when ore transshipment will take place from the temporary wharf, conveyor No. 2 will be extended and will run along the shore to connect the storage hall exiting point to the bridge of the temporary wharf (Figure 7.4). The concept of permanent wharf expects that the second part of the conveyor will be straight between the hall and the wharf.

It is expected that four days will be required for loading an ore carrier.

Figure 7.1 – Permanent Dock Facility Concept

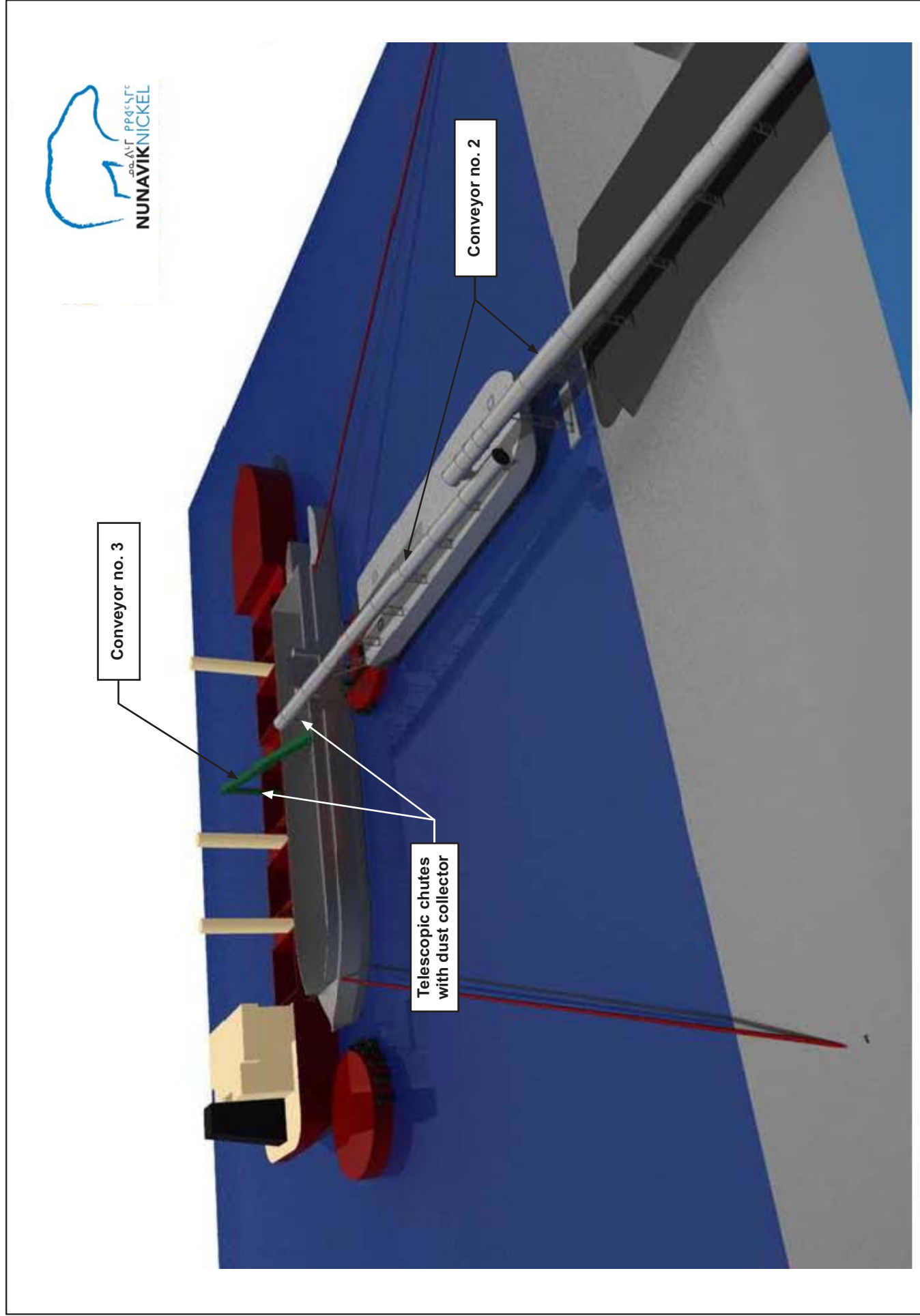

Figure 7.2 – Permanent Dock Facility Concept

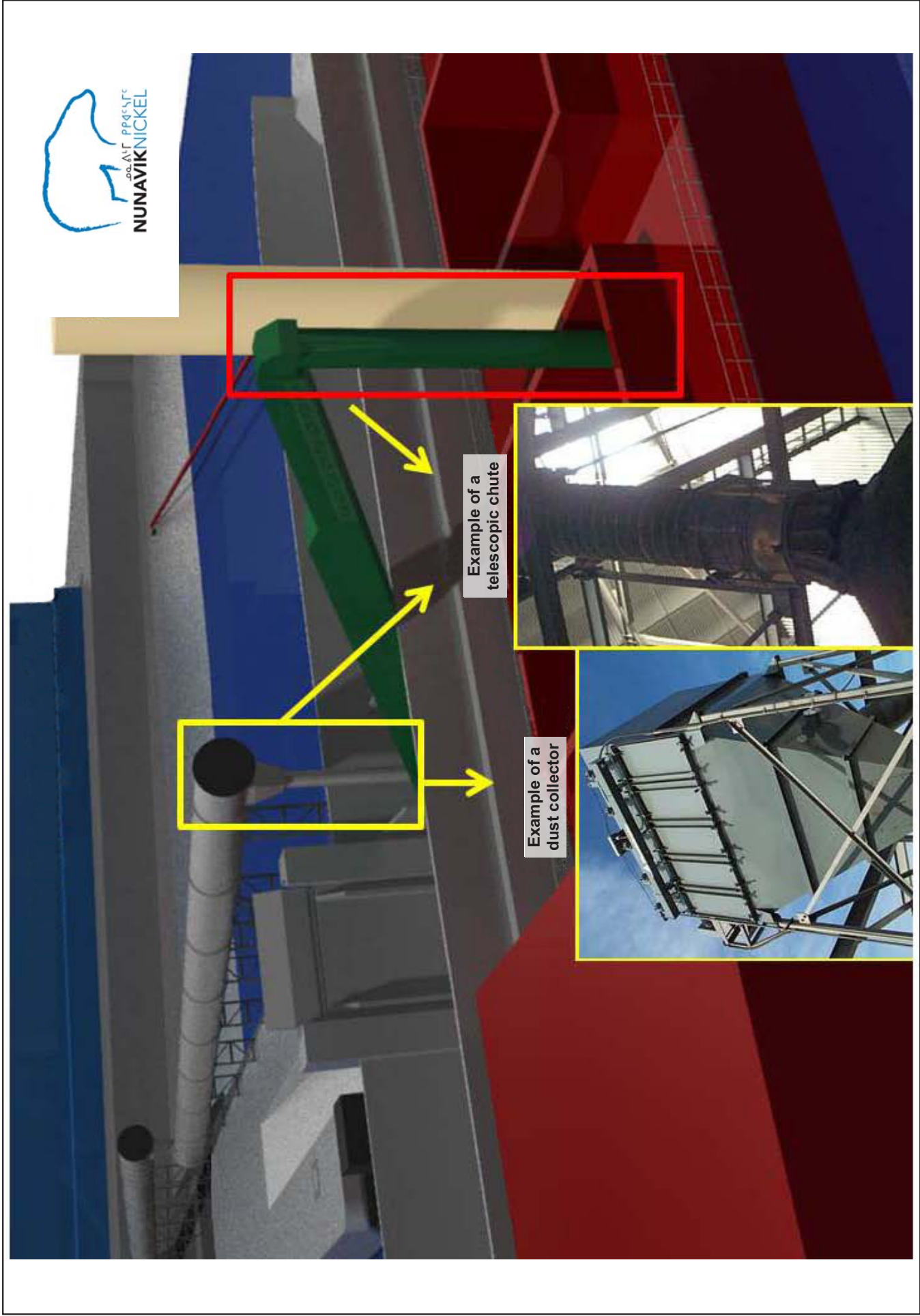

Figure 7.3 – Transfer points

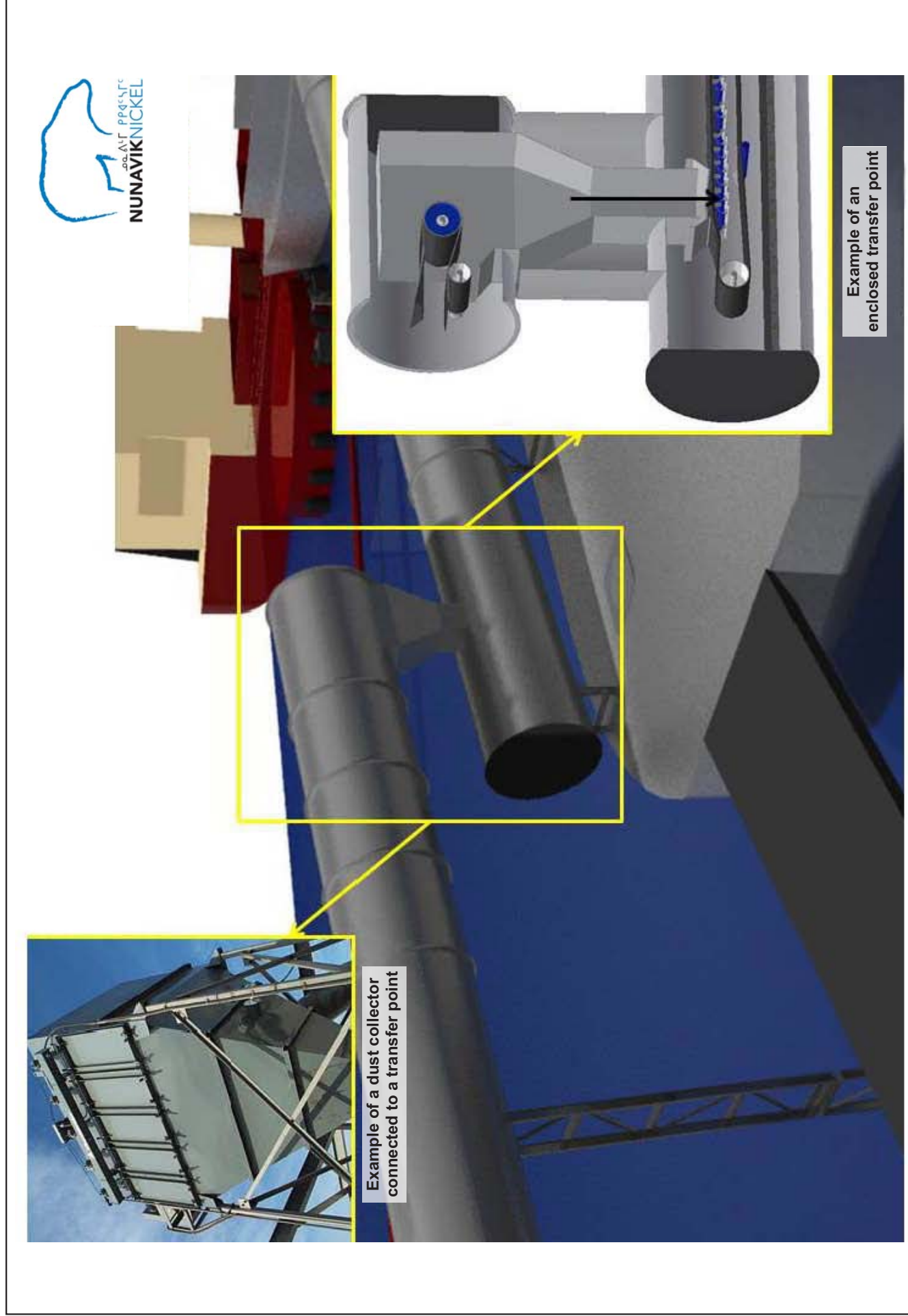
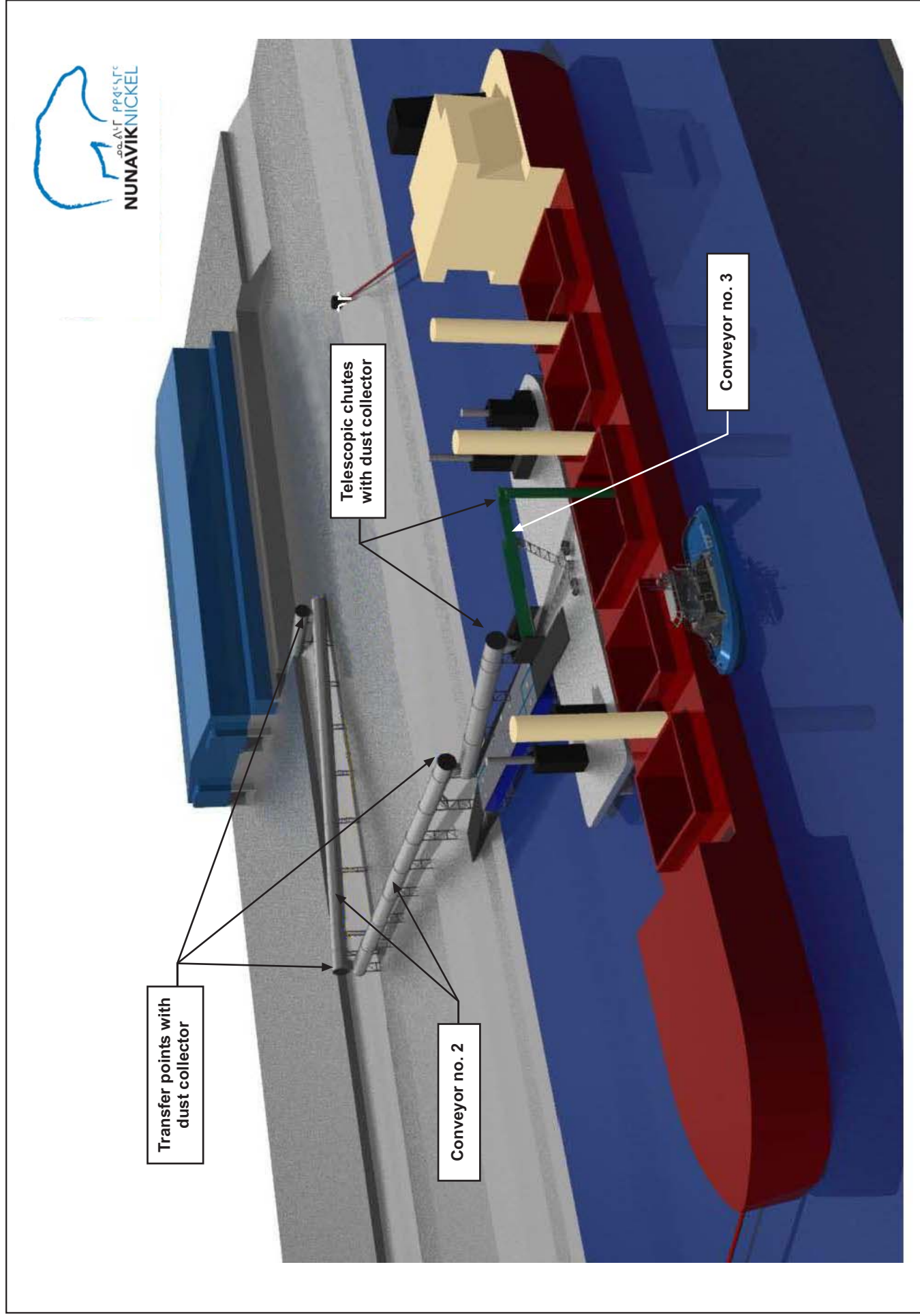
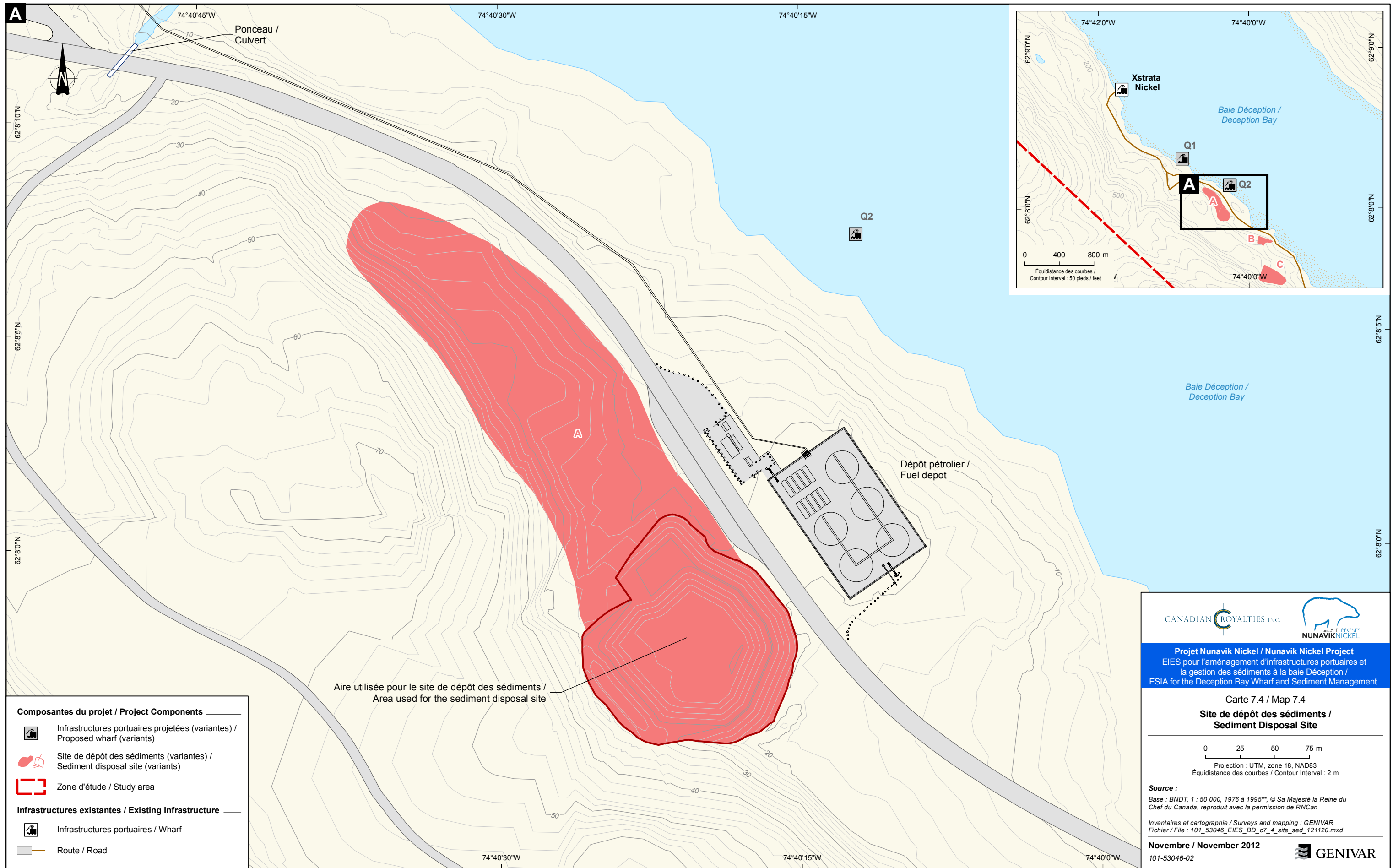

Figure 7.4 – Temporary Dock Facility Concept





7.3 Navigation

The ore carriers used will have a maximum capacity of 25,000 t and a length of approximately 190 m. During the first three years of mining, production will be at its maximum, CRI plans to transport 185,000 t of concentrates using vessels with a capacity of about 25,000 t. Ore carriers should execute approximately seven to eight trips¹³ during the nine months of navigation agreed with Inuits. In addition, there are two ships to transport fuel and one for goods and materials. This brings the annual traffic density to approximately 11 ships.

Materials and fuel will be transported by sea, as much as possible during the period when the bay is ice-free (between June and November). Ships similar to those of the company FEDNAV will be used in summer. These boats have a length of 220 m and a transport capacity of 25,000 t or less. For winter transport, a Class 4 Arctic icebreaker with a maximum capacity of 25,000 t be used. These boats can withstand contact with second-year ice (photo 1, Appendix 20).

The ships itinerary is showed on Map 7.5. It will be the same route as Xstrata's ships, with the same limitations, guided by the landmarks placed on the ground to identify the safe navigation path. Circulating in ice-free waters, vessels will take approximately two hours to make the trip from the mouth of Deception Bay to the pier. When ice is present, it takes at least eight hours to make the same route. Considering 11 trips per year, including two with ice cover, the movement of ships in the bay will totalize approximately 80 hours annually on behalf of CRI.

In accordance with the certificate of authorization issued in 2008 by the MDDEP for PNNI, CRI will not perform transportation in Deception Bay between mid-March and mid-June, unless an emergency situation arising from unexpected events which cannot be resolved by other means than by maritime transport.

The operation area of ships carrying the concentrate was estimated based on the following assumptions:

- the dimensions in plan of the ship will be 27 m x 190 m;
- the wharf will have a length of 150 m;
- a first approach to the pier will be made at a distance equivalent to the width of the ship;
- the distance from wharf can reach 6 m;
- during ore transshipment, the ship's bow or stern may extend approximately 95 m beyond the end of the dock (half of its length), to ensure a good distribution of the concentrate in all holds.

¹³ Each trip includes two trips in Deception Bay, there and back.

Thus, the width of the manoeuvring area perpendicular to the wharf is estimated at 60 m, twice the width of the boat to which the distance away from the wharf is added. The length of the manoeuvring area totalizes 340 m $((95 \times 2) + 150)$. The area is thus of approximately 20,400 m². However, considering that the ship does not always approach perfectly parallel to the wharf, it is conservative to increase this value by a factor of 50%. Based on these assumptions, the size of the manoeuvring area would be approximately 30,000 m².

It should be noted that in a safe manner, assuming a first approach to the wharf at a distance equivalent to the width of the ship was considered. However, this distance may be reduced by half (Tom Grandy, a captain of the Arctic docking at pier, Xstrata, pers. comm., 2012). The width of the manoeuvring area would then be 47 m, reducing its area to 24,000 m².

7.3.1 Ballast water and invasion of foreign species

Vessels navigating in Canada are required by Ballast Water Control and Management Regulations of Canada (DORS/2011-237) to conduct a mid-ocean exchange of ballast water, to avoid potential internal Canadian waters contamination by bacteria and other microorganisms, microalgae, aquatic plants and animals abroad. Ship's ballast water chartered by CRI will be replaced, if any, by salty water drawn from the middle of the Atlantic Ocean, thus avoiding contamination of Deception Bay by foreign species.

Wastewater from ships will be processed and stored on board. They will be disposed of in accordance with international rules, and always outside the Canadian Arctic waters.

In addition, Transport Canada (TC) is developing regulations aimed at preventing undesirable invasive aquatic species which stick to the ships hulls. Risks that such species are imported in Deception Bay by ships are very low due to the temperature of its waters, which are much colder than the ships departure ports or seas through which they pass. CRI will require that ship owners comply with Canadian regulations and international conventions existing on the ballast water management, as well as those adopted or which will come into force in the coming years.

7.4 **Disposal site for the dredged sediment**

As mentioned above, the estimated dredged volume is 43,000 m³. For the design of dredged sediment disposal site, the required landfill volume was set to 50,000 m³. This volume was estimated from the calculated volume added to a safety factor to account for the swelling factor.

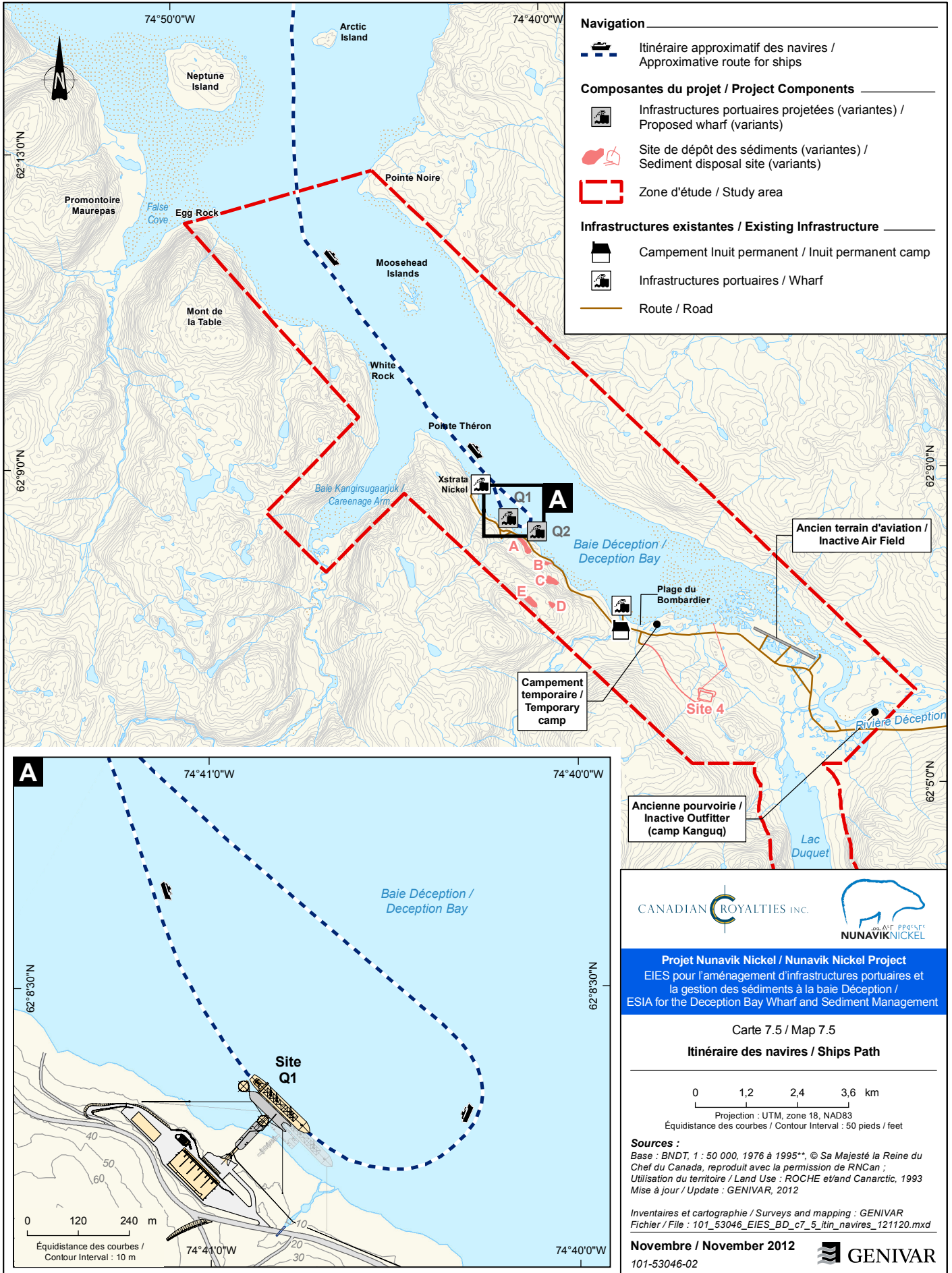

Projet Nunavik Nickel / Nunavik Nickel Project
 EIES pour l'aménagement d'infrastructures portuaires et la gestion des sédiments à la baie Déception / ESIA for the Deception Bay Wharf and Sediment Management

Carte 7.5 / Map 7.5
Itinéraire des navires / Ships Path

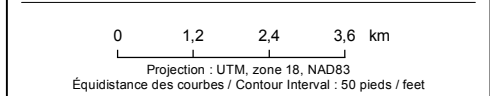

Sources :
 Base : BNDT, 1 : 50 000, 1976 à 1995*. © Sa Majesté la Reine du Chef du Canada, reproduit avec la permission de RNCAN ;
 Utilisation du territoire / Land Use : ROCHE et/and Canarctic, 1993
 Mise à jour / Update : GENIVAR, 2012

Inventaires et cartographie / Surveys and mapping : GENIVAR
 Fichier / File : 101_53046_EIES_BD_c7_5_itin_navires_121120.mxd

Novembre / November 2012
 101-53046-02

The sediment disposal site will be built on land, in front of the oil depot, on the other side of the road, at the bottom of the hill (Map 7.4). During blasting carried out in the summer of 2011, the excavated rocks were stored for future use during the wharf construction. The volume of stored rock is estimated at 262,000 m³.

Briefly, the sediment management site development involves digging a pond in the pile of rocks, thus avoiding the additional rock blasting (plan 101-5304602_F01: Appendix 17). The preliminary design of the pond is described as follows:

- side slope: 2H:1V;
- plateau at the top of the dike: 1 m;
- elevation of the dike: 30 m;
- freeboard: 1 m;
- excavated material: 182,900 m³;
- backfill: 6,000 m³;
- access ramp slope: 8 to 10%;
- pond capacity: 51,000 m³;
- total pond area including turning area: 17,900 m².

The berm will be composed of the rock currently stored. The inner wall may be covered with a separation geotextile if the particle size of the material in place requires it (plan 101-53046-02_F02: Appendix 17).

In a safe manner, the dike slopes were established to 2H:1V. However, a geotechnical analysis including the determination of the stored rocks friction coefficient will decide on the final slope. Slopes can then be accentuated. This data will be defined later in the context of the application for a certificate of authorization.

An estimated residual rock volume of approximately 177,000 m³ remains available. A portion of this volume will be used for the wharf construction. The rest will be stored to the north of wet snow avalanches deflector for future use (road maintenance).

As mentioned in the sector report on the hydrodynamics of Deception Bay (GENIVAR, 2012a), current sedimentation rates at the site and projected at site Q1 are considered low, and the establishment of a maintenance dredging program is not anticipated. However, if a landslide or an avalanche occurs, requiring emergency dredging, the site chosen for the construction of sediment deposition (site A) provides sufficient storage capacity for its expansion.

7.4.1 Dredged sediment transportation

Sediment will be transported by 40-t off-road truck, between the wharf and the disposal site over a distance of approximately 850 m.

The off-road truck's bins will be equipped with a tailgate allowing to close them. It is possible that this equipment cannot ensure perfect sealing of the bin, a small amount of water contained in the sediment could flow out of the bin, but will not let the clay sediment out.

The trucking estimate generated by sediment transport was conducted based on the following assumptions:

- an excavator can handle about 160 m³/h;
- a truck takes about 30 minutes to complete a round trip (loading, moving, unloading, returning);
- a truck can carry approximately 20 m³; therefore truck transports 40 m³/h.

Based on these assumptions, four trucks will be required to meet the excavator production. Consequently, the traffic between the wharf and the sediment management site will be increased by four trucks / hour during the period of dredging.

7.4.2 Water management

Ditch will be built at the bottom of the hill, along the disposal site (plan 101-53046-02_F01: Appendix 17). This ditch will intercept runoff from the hill and cliff, and deflect outwards from the disposal site. A ditch will also be constructed at the bottom of the dike to capture water that may percolate through the berm. Being not contaminated, leaching water from the sediment may be returned to Deception Bay without treatment. A breach will be installed in the upper portion of the berm to create an outlet for the settling water at the sediment surface. A sediment barrier will be installed to capture fine particles that could potentially be there. Water contained in the sediment will gradually and returned by gravity to Deception Bay.

It should be noted that the dredged sediment will be deposited directly on the rock. There is no risk of soil contamination by saline water given that the sediments will not be in contact with them, and the leached water will be collected by ditches and returned via the Deception Bay existing drainage system. On the other side of the road, it is most likely that a portion of the site is already affected by the bay salt water due to its proximity.

A sampling point, before the culvert inlet, will allow sampling and analysis of the surface waters quality before they cross the road (plan 101-53046-02_F01). If required, sediment retention structures may be constructed in the ditch to reduce the concentrations of suspended solids (sediment barrier, filter berm or other structure to in order to meet the surface waters quality criteria).

7.5 Closing and decommissioning

7.5.1 Wharf

At the end of its activities, CRI wishes to transfer the wharf to the regional government. If an agreement was not possible, it will be dismantled and demolition materials managed under the procedure in place:

- sorting of materials;
- transportation of the recyclable materials toward the south;
- packaging and transportation of hazardous waste toward the south;
- transportation of non-recyclable materials to the Expo site: combustible materials will be burned, and non-combustible materials as well as the ashes will be buried in the landfill in the northern environment.

7.5.2 Management sediment site

As soon as the sediment will be sufficiently dried or frozen to allow the machinery to roll on its surface, it will be covered with granular materials. The platform thus formed will serve as a storage area during the period of wharf operation. At the end of operations, the site will be liberated, the only remaining infrastructure will be a platform equipped with an access which could be used as a bay observation point.

7.6 Completion schedule

Tables 7.4 and 7.5 present the delivery schedule proposed for the development of permanent and temporary wharves. Work will begin in mid-June, as soon as the weather conditions allow it, and should be completed by mid-November for the permanent wharf and in mid-August for the temporary wharf.

7.7 Costs of the work

The wharf project cost is estimated at \$70 million.

7.8 Required equipment

It should be noted that all operational equipment necessary for the development of port facilities at Deception Bay will respect Quebec regulations in force, and the machinery and other equipments will be installed on land or water depending on the nature of the work to achieve.

Table 7.6 lists the equipment that will be potentially required.

7.9 Estimation of required personal

A preliminary estimation of the number of workers required for the construction of the wharf was completed. Table 7.7 presents the estimated number of workers for each of the tasks to be completed.

Table 7.6 Machinery and equipment

Terrestrial	On water
Drills	Barges
Trucks (off-road and on-road)	Tugboats
Bulldozers	Clam bucket
Loaders	Crane 220T
Graders	Vibrator for sheet pile driving
Compressors	Compressors
Excavators	Concrete hopper
Tanker truck with fuel and biodegradable lubricant	Hammer drill tubular piles
Off-road trucks	
Cranes	
Bus	
Vans	
Mixer for mixing dry components of the concrete	
Concrete mixers	
Concrete pump	

Table 7.7 Estimated number of workers

Task	Number of workers
Dredging	20
Vibratory pile driving	20
Riprap	10
Concreting	20
Site operation	10
Cut / fill of the sediment basin	10
Supervision (contractor and CRI)	10
Total	100

8. ASSESSMENT OF ENVIRONMENTAL EFFECTS

8.1 Method for identifying and assessing environmental effects

The methodological approach to assessing environmental effects involves two broad stages, that is, the identification and assessment of effects.

The identification of effects consists of establishing the components of the physical, biological and human environments likely to be impacted by project activities. Effects assessment then consists in defining the magnitude of the effects associated with doing the project. The effect's magnitude for an environmental component is a function of three parameters: intensity, duration and extent.

The first step in determining an effect's magnitude involves relating an environmental component's environmental value to the degree of disturbance anticipated, which makes it possible to identify the effect's intensity. The second step consists in evaluating the effect's duration, so as to create a duration-intensity index. The third step leads to an assessment of the magnitude of the effect, by introducing its extent.

Lastly, the significance of residual effects is evaluated by factoring in the use of mitigation measures.

8.1.1 Determining the magnitude of an environmental effect

8.1.1.1 Intensity of the effect

The first step in determining an effect's magnitude involves evaluating the effect's intensity by relating the environmental component's environmental value to the degree of disturbance expected.

Value of environmental components

A component's value is determined according to its ecosystem and/or sociocultural and economic importance. In some cases, no rating is assigned to any of these values.

Ecosystem value

A component's ecosystem value is determined solely for the components of a biological environment. This value expresses a component's relative importance in terms of its interest to the ecosystem, factoring in its characteristics (sensitivity, integrity, resilience), its role and its function. It also includes notions such as representativeness, distribution, diversity, sustainability, scarcity and uniqueness. Its value can be high, moderate or low.

High: The component has an important role in the ecosystem, is of substantial interest in terms of biodiversity, and has extraordinary attributes on which there is a consensus among the scientific community with respect to conservation and/or protection.

Moderate: The component is of strong interest and has recognized attributes for which conservation and protection are a concern, though there is no consensus.

Low: The component's interest and attributes are not of much concern in terms of conservation and protection.

Sociocultural and economic value

An environmental component's sociocultural and economic value considers its importance to the local or regional population, interest groups, managers and specialists. Among other things, it expresses a public or political desire or will to conserve the integrity or original character of a component. It is considered:

High: When the component is covered by legal or regulatory protection measures (endangered or vulnerable species, known wildlife habitats, conservation parks, etc.) or it provides ecoservices (such as a wetland that filters water), or is essential to human activities (potable water, listed archaeological sites).

Moderate: When a component is a valued environmental component socially, economically or culturally, or it is used by a substantial portion of the population affected but not subject to legal protection.

Low: When a component is rarely or never valued or used by the population.

Overall environmental value

When a component's importance factors in its ecosystem value as well as its sociocultural and economic value, it is determined according to the stronger of the two values (table 8.1).

Table 8.1 Grid for evaluating the importance of components of the biological and human environments

Sociocultural and economic value	Ecosystem value		
	High	Moderate	Low
High	High	High	High
Moderate	High	Moderate	Moderate
Low	High	Moderate	Low

8.1.1.2 Degree of disturbance

The **degree of disturbance** measures the magnitude of negative changes made to the structural and functional attributes of the component affected by the project. Three levels of disturbance are used to characterize the changes:

High: When the intervention leads to the loss or modification of all or the key attributes specific to the affected component so that there is a risk that it will lose its integrity.

Moderate: When the intervention leads to the loss or modification of some attributes specific to the affected component which could diminish its attributes without necessarily compromising its integrity.

Low: When the intervention does not significantly modify the attributes specific to the affected component so that it will retain its integrity without too much erosion of its attributes.

8.1.1.3 Intensity

Associating environmental value with the degree of disturbance yields the first parameter used in assessing an impact's importance, **intensity**. Intensity ranges from high to low, based on the valuation grid in table 8.2.

Table 8.2 Grid for assessing an impact's intensity

Degree of disturbance	Environmental value		
	High	Moderate	Low
High	High	Moderate	Moderate
Moderate	High	Moderate	Low
Low	Moderate	Low	Low

8.1.2 Duration/intensity association

The second step in establishing an impact's importance involves associating the impact's duration with its intensity, to create a duration/intensity index.

8.1.2.1 Duration of the effect

Duration specifies the effect's time aspect. It describes, in relative terms, the period of time over which the component affected will feel an intervention's repercussions. The terms "permanent", "temporary," and "momentary" are used to describe this time period.

Permanent: The impact has consequences for the infrastructure's lifespan or the impacts are irreversible.

Temporary: The impact is felt during a project activity or, at most, during project execution.

Momentary: The effect dissipates promptly (that is, less than one week in this project's framework).

8.1.2.2 Duration / intensity index

Associating the effect's duration and previously identified intensity yields the second parameter used in assessing an impact's importance, the **duration - intensity index**. It ranges from high to low, based on the valuation grid in table 8.3.

Table 8.3 Grid for assessing the duration - intensity index

Duration	Intensity		
	High	Moderate	Low
Permanent:	High	High	Moderate
Temporary	High	Moderate	Low
Ephemeral	Moderate	Low	Low

8.1.3 Magnitude of the effect

The third and final step in establishing an effect's magnitude involves association the effect's extent with the duration/intensity index.

8.1.3.1 Extent of the effect

Extent characterizes the spatial aspect of the effect generated by an intervention in the environment. It refers to the distance or area over which the disturbance will be felt. The terms "regional," "local" and "point" are used to characterize extent:

Regional: The extent is regional when the intervention has repercussions for one or more environmental components located at a substantial distance from the project, or when the intervention affects the "regional" environment.

Local: The extent is local when the intervention affects a relatively limited area or a number of similar components located close to the project, or when a "local" environment is affected.

Point: The extent is characterized as a "point" extent when the intervention only affects an environmental component located close to the project, or when the disturbance is felt in a limited, well-defined area on the project site or neighbouring sector.

8.1.3.2 Extent/duration/intensity relationship

Associating the effect's extent with the duration/intensity index established previously pinpoints the **significance** of the environmental effect. It is characterized as "major", "moderate" or "minor":

Major: Major significance means the effect is permanent and affects the component's integrity, diversity and sustainability. Such an effect markedly or irreversibly alters the quality of the environment.

Moderate: Moderate significance involves material repercussions for the component affected, leading to a partial alteration of its nature and use, without jeopardizing its survival.

Minor: Minor significance involves limited repercussions for the component affected, leading to a minor alteration of its nature and use.

The significance of the effect is established using the valuation grid shown in table 8.4.

Table 8.4 Grid for assessing the effect's significance

Extent	Duration - intensity index		
	High	Moderate	Low
Regional	Major	Major	Moderate
Local	Moderate	Moderate	Minor
Point	Moderate	Minor	Minor

8.1.4 Mitigation measures and residual environmental effects

Once the environmental effects have been identified and valued, mitigation measures are identified to reduce the significance of the effects. The measures are intended to mitigate or correct negative effects to provide for better integration of the project into the environment.

Using mitigation measures then makes it possible to reassess the environmental effects, which then become **residual environmental effects**, that is, the effect that persists after mitigation measures have been applied. The two types of residual effects that may persist subsequent to the use of mitigation measures are characterized as "major" and "minor."

Minor residual effect: Means that the residual effect is deemed to have moderate to minor significance, based on the grid in table 8.4.

Major residual effect: Means that despite the use of mitigation measures, the residual effect is still substantial according to the grid in table 8.4.

8.2 Analysis of environmental effects

The assessment of environmental effects is presented in three parts. The first part covers the permanent port infrastructures and the second covers the deposit of land sediment. The effects of the temporary port infrastructures are not assessed separately, since their construction and operation will have the same effects as those caused by the permanent infrastructures. A third part presents a summary of the project's effects on two high-value environmental components (issues)—marine mammals and land use by the Inuit for traditional purposes.

The potential environmental effects are identified using a matrix showing the relationship between the project components of the construction and operation phases (impact sources) and the environmental components. Two series of data

sheets, one for port infrastructures (temporary and permanent) and one for the dumping of land sediment, present the analysis of each potential environmental effect. For certain project components, a single data sheet for the construction and operation phases is presented, since the potential effects are the same.

The modification phase (work that would include, for example, the addition of a cell or enlargement of a structure) is not covered by a separate assessment. The same effects as those expected in the construction phase are likely to occur, since the same activities and work are likely to be performed.

Lastly, the project will have positive effects on several socioeconomic components of the setting. No significance has been attributed to these effects, but they are nonetheless described in the data sheets.

The assessment data sheets include:

- the ecosystemic, sociocultural and economic values;
- a justification of the ecosystemic, sociocultural and economic values accorded to each environmental component (if applicable);
- the source(s) of the potential effects;
- a brief description of the potential effects;
- the determination of the significance environmental effect according to the method presented in section 8.1, before the application of attenuation measures;
- the proposed attenuation measures for reducing the significance of the effects. These measures will be monitored to ensure their implementation. A list of standard attenuation measures for the work and regular activities is presented in Appendix 21.
- if required, explanatory or justification notes to support assessment of the effects;
- the significance of the residual effect;
- the follow-up, if deemed relevant to do so.

The structure of the data sheets is presented below. Their numbering is entered in the interaction matrices.

Environmental component:		
<i>Ecosystemic value:</i>		
<i>Sociocultural and economic values:</i>		
Source(s) of the effect		
<i>Phase(s):</i>		
<i>Activity(ies):</i>		
Description of the potential effects		
Degree of disturbance:	Intensity of the effect:	Duration of the effect:
Duration-intensity index:	Scope of the effect:	
	Significance of the effect:	
Attenuation measures/Monitoring		
Notes		
		Significance of the residual effect:
Follow-up		

8.2.1 Port infrastructures

In the construction phase, the sources of the effects include dredging and the following activities: pile and sheet-pile driving by vibro-driving and piling, placement of cell protection ballast and placement of various dock structures (access ramps, barges, etc.). No blasting is required.

In the operation phase, the sources of the effects include the transshipment of ore concentrate from the concentrate hall to the ore carriers and movement of the latter within Deception Bay. Navigation also includes the movement of supply ships carrying materials and petroleum products. Aside from a visual inspection of the infrastructures, no major maintenance work (such as dredging) likely to cause significant environmental effects is foreseen.

The sources of the effects for the construction and operation of the **temporary port infrastructures** are limited to pile driving, the use of heavy machinery, ore transshipment and navigation.

Table 8.5 shows the relationship between the potential effects of the port infrastructures and those of the environment. The assessment data sheets can be found on the following pages.

Table 8.5 Identification of potential effects matrix - Temporary and permanent port infrastructures

Nature of potential impacts PI-x / □ Negative impact PI-x / ■ Positive impact		Sources of potential effects					
		Implementation phases					
		Construction	Operation	Modification*	Decommissioning and closure		
Environmental components	Physical setting	Dredging					
		Activities related to the construction of the port infrastructures*					
		Ore transshipment					
		Navigation					
		Maintenance					
	Biological setting	Sediment stability and bathymetry	PI-1	-		PI-1	
		Hydraulic and sedimentological conditions	-	PI-2		PI-2	
		Sediment quality		PI-3	PI-3	PI-3	
		Surface water quality		PI-4	PI-4	PI-4	
		Air quality		PI-5	PI-5	PI-5	□ / ■
Ice regime		See components 14 and 15 of the human setting					
Biological setting	Marine plankton community	PI-6	-		PI-6		
	Marine invertebrates	PI-7	-		PI-7	■	
	Aquatic vegetation	PI-8	-		PI-8		
	Marine piscifauna and fish habitat		PI-9		PI-9	■	
	Marine mammals						
	Species of fauna with special status			PI-19			
	PI-10			PI-10			
Avian fauna (wildfowl)	PI-11			PI-11			

Table 8.5 Identification of potential effects matrix - Temporary and permanent port infrastructures (cont.)

Nature of potential impacts PI-x / □ Negative impact PI-x / ■ Positive impact		Sources of potential effects				
		Implementation phases				
Environmental components	Human setting	Construction		Operation	Modification**	Decommissioning and closure
		Dredging	Activities related to the construction of the port infrastructures*	Ore transshipment	Navigation	
Ambient noise		PI-12	PI-12	-	PI-12	□ / ■
Economy		PI-13	PI-13	-	PI-13	
Jobs		PI-14	PI-14	-	PI-14	
Health		PI-15	PI-15	-	PI-15	■
Land for use by the Inuit for traditional purposes		PI-16	-	PI-20	PI-16	■
Navigation		PI-17	-	PI-21	PI-17	■
Landscape			PI-18	-		

* Including the temporary dock. These activities are mainly pile and sheet-pile driving, the assembly of various structures and the placement of cell protection ballast.

** According to the type of modifications. The same impacts as those expected in the construction phase are likely to occur in the modification phase, since the same activities and work are likely to be performed.

Data sheet PI-1

Environmental component

Sediment stability and bathymetry

Ecosystemic value: Average

The stability of the seabed permits the long-term development of a diversified flora and fauna (Gray and Elliott, 2009).

Sociocultural and economic value: N/A

Sources of the effect

Phases: Construction/Modification

Activity: Dredging

Description of the potential effects <ul style="list-style-type: none"> • Risk of slippage of undersea sediment if the excavation slopes are unsuitable. • Modification of the bathymetric profile 		
Degree of disturbance: High	Intensity of the effect: Average	Duration of the effect: Permanent
Duration-intensity index: High	Scope of the effect: Occasional	
Significance of the effect: Average		
Attenuation measures/Monitoring <ul style="list-style-type: none"> • Ensure that the excavation slopes in the dredging area are 3H:1V to ensure the stability of adjoining sediment. • Restrict the dredging area to a minimum. • Use the grab positioning system in real time to avoid over-dredging. • Ensure the bathymetric measurements are achieved. • Conduct a bathymetry of the dredged area after the dredging to confirm that the slopes respect the design plans and drawings. 		
Notes		
Significance of the residual effect: Not significant		
Follow-up A follow-up is not necessary.		

Data sheet PI-2

Environmental component

Hydraulic and sedimentological conditions

Ecosystemic value: Large

The hydraulic and sedimentological conditions encompass various parameters designating the flow characteristics (water depth, flow speed, etc.) and sediment movement in the intervention area. They create a balance between coastal erosion and sedimentary deposit that prevents this erosion (Herbich, 1992; Bray *et al.*, 1997; Bray, 2008).

Sociocultural and economic value: N/A

Sources of the effect

Phases: Construction/Modification

Activity: Work related to the construction of the port infrastructures

Description of the potential effects		
<ul style="list-style-type: none"> Modification of the natural sedimentary dynamic on the coast (Bray <i>et al.</i>, 1997). 		
Degree of disturbance: Low	Intensity of the effect: Average	Duration of the effect: Permanent
Duration-intensity index: High	Scope of the effect: Occasional	
Significance of the effect: Average		
Attenuation measures/Monitoring		
<ul style="list-style-type: none"> None 		
Notes		
<ul style="list-style-type: none"> The design of the port infrastructures was completed while keeping to a minimum the submerged structures that could alter flow patterns and the sedimentary dynamic. This design allows free passage of water along the shore. The natural sedimentary deposit is low in comparison to the size of Deception Bay, which means there is very little matter in suspension. In a similar manner to Deception Bay overall, site Q1 is not a setting that has significant sedimentary movement. The sedimentation rate is estimated at ± 3 mm/year (GENIVAR, 2012a). 		
Significance of the residual effect: Not significant		
Follow-up		
A follow-up is not necessary.		

Data sheet PI-3

Environmental component

Sediment quality

Ecosystemic value: Large

Permits the development of a diversified flora and fauna (Gray and Elliott, 2009).

Sociocultural and economic value: N/A

Sources of the effect

Phases: Construction/Operation/Modification

Activities: Dredging/Work related to the construction of the port infrastructures/Ore transshipment

Description of the potential effects		
<ul style="list-style-type: none"> • Risk of sediment contamination from: <ul style="list-style-type: none"> ○ An accidental leak or spill of oil or other contaminants from heavy machinery or construction equipment; ○ A loss of ore during its transshipment from the concentrate hall to the carrier. 		
Degree of disturbance: Low	Intensity of the effect: Average	Duration of the effect: Temporary
Duration-intensity index: Average	Scope of the effect: Occasional	
Significance of the effect: Minor		
Attenuation measures/Monitoring		
<ul style="list-style-type: none"> • Standard measures 1 to 9. 		
Notes		
<ul style="list-style-type: none"> • The ore conveyors will be installed inside enclosed structures. 		
Significance of the residual effect: Not significant		
Follow-up		
A follow-up is not necessary.		

Data sheet PI-4

Environmental component

Surface water quality

Ecosystemic value: Large

Assure optimal conditions for the development of marine flora and fauna (Gray and Elliott, 2009).

Sociocultural and economic value: N/A

Sources of the effect

Phases: Construction/Operation/Modification

Activities: Dredging/Work related to the construction of the port infrastructures/Ore transshipment

Description of the potential effects		
<ul style="list-style-type: none"> • Increase in SS (suspended solids) concentrations during dredging of the work site and formation of a dispersion plume. The SS concentrations close to the work area and on the opposite shore could reach values above 100 mg/L, or even 300 mg/L. • Depending on the weather conditions (wind strength and direction), the SS concentrations could increase in other sectors of Deception Bay. • Risk of water contamination from an accidental leak or spill of oil or other contaminants from the machinery used for the site work. • Risk of water contamination from a loss of ore during its transshipment from the concentrate hall to the carrier. • The air bubble system used to break up the ice could stir up contaminated sediments into suspension. • The ship maneuvers could stir up contaminated sediment into suspension. 		
Degree of disturbance: High	Intensity of the effect: High	Duration of the effect: Temporary
Duration-intensity index: High	Scope of the effect: Local	
Significance of the effect: Average		
Attenuation measures/Monitoring		
The renewed suspension and dispersion of dredged sediment can be substantially curtailed by closely managing the work, the type of equipment used and the operational behaviours; the following measures are recommended:		
Work management		
<ul style="list-style-type: none"> • Restrict the dredging area to a minimum. • Use a grab positioning system in real time to avoid over-dredging. • Halt the dredging work during periods of bad weather (e.g. storms, strong winds). 		

Equipment

- Use an environmental clamshell dredge which is more watertight than conventional models.
- Only use one dredge at a time.

Operational behaviours

- Maneuver the sediment carefully so that it remains as cohesive as possible.
 - The clamshell raising and lowering speed must be slow and controlled.
 - The dredge operators must be made aware of the importance of paying special attention to the maneuvers, especially avoiding abrupt movements or when leveling the seabed with a dredge or a power shovel.
 - Check the clamshell watertightness throughout the operations.
 - Check the barge compartment watertightness throughout the operations.
 - Do not overload the barge or use it during harsh weather conditions.
 - Limit the speed of the dredge and the barge in shallow water.
 - Do not overload the embankment or the area close to shore so as to reduce the risk of land slip or sediment stripping.
-
- Standard measures 1 to 9.

Notes

- The ore conveyors will be installed inside enclosed structures.
- Dust extractors will be installed at all transfer points on the conveyor system.
- The transshipped ore is wet.
- None of the physical-chemical analyses conducted on sediments since 2006 show any contamination (hydrocarbons, heavy metals, PCBs, PAHs, asbestos).

Significance of the residual effect: Not significant

Follow-up

- Monitoring of SS concentrations will be conducted during the dredging work and for some time after the work in order to check the behaviour of the dispersion plume (Section 9).

Data sheet PI-5

Environmental component

Air quality

Ecosystemic value: N/A

Sociocultural and economic value: Large

Air quality is an element deemed to be important since the work will be conducted in a natural setting relatively undisturbed by human activity.

Sources of the effect

Phases: Construction/Operation/Modification

Activities: Dredging/Work related to the construction of the port infrastructures/Ore transshipment

Description of the potential effects		
<ul style="list-style-type: none"> Emission of atmospheric pollutants and dust from the movement of trucks, the operation of heavy machinery, construction equipment and power generator sets. Risk of dust emissions when transshipping the ore. 		
Degree of disturbance: High	Intensity of the effect: High	Duration of the effect: Temporary
Duration-intensity index: High	Scope of the effect: Occasional	
Significance of the effect: Average		
Attenuation measures/Monitoring		
<ul style="list-style-type: none"> Standard measures 12 to 17. Use of Arctic diesel. 		
Notes		
<ul style="list-style-type: none"> The ore conveyors will be installed inside enclosed structures. Dust extractors will be installed at all transfer points on the conveyor system. The transshipped ore is wet. 		
Significance of the residual effect: Not significant		
Follow-up		
A follow-up is not necessary.		

Data sheet PI-6

Environmental component

Marine plankton community

Ecosystemic value: Large

Base of the marine trophic chain.

Sociocultural and economic value: Average

Sociocultural and economic: Limited interest and not used by the population (GENIVAR, 2007). According to Kumar (2010), the nutrients cycle in a coastal ecosystem where the marine phytoplankton renders an ecological service to humankind is evaluated at between \$170 and \$30,451/ha/year.

Sources of the effect

Phases: Construction/Modification

Activity: Dredging

Description of the potential effects <ul style="list-style-type: none"> • The increase in SS concentrations generated by the dredging activities risks affecting certain biological functions of the zooplankton in the immediate area of the work and within the dispersion plume. • A large volume of sediment stirred up into suspension could disturb filter feeding organisms (Morton, 1977). 		
Degree of disturbance: High	Intensity of the effect: High	Duration of the effect: Temporary
Duration-intensity index: High	Scope of the effect: Local	
Significance of the effect: Average		
Attenuation measures/Monitoring <p>The renewed suspension and dispersion of dredged sediment can be substantially curtailed by closely managing the work, the type of equipment used and the operational behaviours; the following measures are recommended:</p> <p>Work management</p> <ul style="list-style-type: none"> • Restrict the dredging area to a minimum. • Use a grab positioning system in real time to avoid over-dredging. • Halt the dredging work during periods of bad weather (e.g. storms, strong winds). <p>Equipment</p> <ul style="list-style-type: none"> • Use an environmental clamshell dredge which is more watertight than conventional models. • Only use one dredge at a time. 		

Operational behaviours

- Maneuver the sediment carefully so that it remains as cohesive as possible.
- The clamshell raising and lowering speed must be slow and controlled.
- The dredge operators must be made aware of the importance of paying special attention to the maneuvers, especially avoiding abrupt movements or when leveling the seabed with a dredge or a power shovel.
- Check the clamshell watertightness throughout the operations.
- Check the barge compartment watertightness throughout the operations.
- Do not overload the barge or use it during harsh weather conditions.
- Limit the speed of the dredge and the barge in shallow water.
- Do not overload the embankment or the area close to shore so as to reduce the risk of land slip or sediment stripping.

Notes

Significance of the residual effect: Not significant

Follow-up

A follow-up is not necessary.

Data sheet PI-7

Environmental component

Marine invertebrates

Ecosystemic value: Large

Important elements in the marine trophic chain (Gray and Elliott, 2009).

Sociocultural and economic value: Average

Several species are harvested by the population (e.g. blue mussel) (GENIVAR, 2007b).

Source of the effect

Phases: Construction/Modification

Activity: Dredging

<p>Description of the potential effects</p> <ul style="list-style-type: none"> The dredging work will destroy the benthic fauna in the dredged area over a surface area of 9,350 m², which corresponds to the surface area of two sheet pile cells and their stone ballast. Burial of the benthic fauna in the sectors most affected by sedimentation, specifically in the immediate area of the work and along the coast of Deception Bay in the dispersion plume diffusion area. The suspended matter, from the stirring up of significant volumes of sediment, has a lower food density than that observed in matter stirred up into suspension during natural phenomena (turbulence, storms). Saila <i>et al.</i> (1972) say that the low food density included in the matter stirred up into suspension affects the organisms depending on this food (filter feeders and detritus feeders). 		
Degree of disturbance: High	Intensity of the effect: High	Duration of the effect: Temporary
Duration-intensity index: High	Scope of the effect: Local	
Significance of the effect: Average		
<p>Attenuation measures/Monitoring</p> <p>The renewed suspension and dispersion of dredged sediment can be substantially curtailed by closely managing the work, the type of equipment used and the operational behaviours; the following measures are recommended:</p> <p>Work management</p> <ul style="list-style-type: none"> Restrict the dredging area to a minimum. Use a grab positioning system in real time to avoid over-dredging. Halt the dredging work during periods of bad weather (e.g. storms, strong winds). 		

Equipment

- Use an environmental clamshell dredge which is more watertight than conventional models.
- Only use one dredge at a time.

Operational behaviours

- Maneuver the sediment carefully so that it remains as cohesive as possible.
- The clamshell raising and lowering speed must be slow and controlled.
- The dredge operators must be made aware of the importance of paying special attention to the maneuvers, especially avoiding abrupt movements or when leveling the seabed with a dredge or a power shovel.
- Check the clamshell watertightness throughout the operations.
- Check the barge compartment watertightness throughout the operations.
- Do not overload the barge or use it during harsh weather conditions.
- Limit the speed of the dredge and the barge in shallow water.
- Do not overload the embankment or the area close to shore so as to reduce the risk of land slip or sediment stripping.

Notes

- The cell protection stone ballast will be colonized by epibenthos. The species will differ from those found in the soft bottom in the Q1 sector, thereby helping create a broader diversity of aquatic habitat.

Significance of the residual effect: Not significant

Follow-ups (Section 9)

- Monitoring of SS concentrations will be conducted during the dredging work and for some time after the work in order to check the behaviour of the dispersion plume.
- A follow-up will be conducted of benthic habitats having been affected by the dispersion plume and sedimentation.
- A follow-up will be conducted to check the colonization of epibenthos on the stone ballast.

Data sheet PI-8

Environmental component

Aquatic vegetation

Ecosystemic value: Large

The aquatic vegetation creates a heterogeneity and complexity of habitats conducive to benthic invertebrates and fish (shelter, growth and food) (Skilleter, 1994; Turner *et al.*, 1999; Lindholm, 1999).

Sociocultural and economic value: Average

Ecological "nursery" service for benthic organisms and fish evaluated at between \$77 and \$164/ha/year (Kumar, 2010).

Source of the effect

Phases: Construction/Modification

Activity: Dredging

Description of the potential effects		
<ul style="list-style-type: none"> • Destruction of aquatic vegetation in the area to be dredged over a surface area of 9,350 m². • Burial of the aquatic vegetation in the sectors most affected by sedimentation, specifically in the immediate area of the dredging work and along the coast of Deception Bay in the dispersion plume diffusion area. 		
Degree of disturbance: High	Intensity of the effect: High	Duration of the effect: Temporary
Duration-intensity index: High	Scope of the effect: Local	
Significance of the effect: Average		

Attenuation measures/Monitoring

The renewed suspension and dispersion of dredged sediment can be substantially curtailed by closely managing the work, the type of equipment used and the operational behaviours; the following measures are recommended:

Work management

- Restrict the dredging area to a minimum.
- Use a grab positioning system in real time to avoid over-dredging.
- Halt the dredging work during periods of bad weather (e.g. storms, strong winds).

Equipment

- Use an environmental clamshell dredge which is more watertight than conventional models.
- Only use one dredge at a time.

Operational behaviours

- Maneuver the sediment carefully so that it remains as cohesive as possible.
- The clamshell raising and lowering speed must be slow and controlled.
- The dredge operators must be made aware of the importance of paying special attention to the maneuvers, especially avoiding abrupt movements or when levelling the seabed with a dredge or a power shovel.
- Check the clamshell watertightness throughout the operations.
- Check the barge compartment watertightness throughout the operations.
- Do not overload the barge or use it during harsh weather conditions.
- Limit the speed of the dredge and the barge in shallow water.
- Do not overload the embankment or the area close to shore so as to reduce the risk of land slip or sediment stripping.

Notes

- The cell protection stone ballast will be colonized by aquatic vegetation that needs a fixed substrate on which to grow. The species will differ from those found in the soft bottom, thereby helping create a broader diversity of aquatic habitat.

Significance of the residual effect: Not significant

Follow-ups (Section 9)

- Monitoring of SS concentrations will be conducted during the dredging work and for some time after the work in order to check the behaviour of the dispersion plume.
- A follow-up will be conducted of benthic habitats having been affected by the dispersion plume and sedimentation.
- A follow-up will be conducted to check the colonization of aquatic vegetation on the protective stone ballast.

Data sheet PI-9

Environmental component

Piscifauna and fish habitat

Ecosystemic value: Large

Important element of the marine trophic chain.

Sociocultural and economic values: Large

The Inuit fish for several different species, which represent a major food source for the Nunavik communities. Fishing is an integral part of their way of life (GENIVAR, 2007b). According to Kumar (2010), the ecological service rendered by a coastal ecosystem in terms of providing food is evaluated at \$7,549/ha/year.

Sources of the effect

Phase: Construction/Modification

Activities: Dredging/Work related to the construction of the port infrastructures

<p>Description of the potential effects</p> <ul style="list-style-type: none"> The increase in SS concentrations generated by the dredging activities is likely to affect fish directly (blocking of gills, abrasion of membranes, effects on egg and larvae growth and survival, effects on the food regime, reproduction and migration) or indirectly through the deterioration of habitat (Rieussec, 2008). Burial of the benthic habitat used by fish in the sectors most affected by sedimentation, specifically in the immediate area of the work and along the coast of Deception Bay in the dispersion plume diffusion area. The noise caused by the work disturbs the fish and causes them to move away. Destruction of fish habitat below the sheet-pile cells and in the portion of stone ballast in cell 2 to above the HHWMT level: surface area of 1,430 m². 		
<p>Degree of disturbance: High</p>	<p>Intensity of the effect: High</p>	<p>Duration of the effect: Temporary/Permanent</p>
<p>Duration-intensity index: High</p>	<p>Scope of the effect: Local</p>	
<p>Significance of the effect: Average</p>		
<p>Attenuation measures/Monitoring</p> <p>The renewed suspension and dispersion of dredged sediment can be substantially curtailed by closely managing the work, the type of equipment used and the operational behaviours; the following measures are recommended:</p> <p>Work management</p> <ul style="list-style-type: none"> Restrict the dredging area to a minimum. Use a grab positioning system in real time to avoid over-dredging. Halt the dredging work during periods of bad weather (e.g. storms, strong winds). 		

Equipment

- Use an environmental clamshell dredge which is more watertight than conventional models.
- Only use one dredge at a time.

Operational behaviours

- Maneuver the sediment carefully so that it remains as cohesive as possible.
- The clamshell raising and lowering speed must be slow and controlled.
- The dredge operators must be made aware of the importance of paying special attention to the maneuvers, especially avoiding abrupt movements or when leveling the seabed with a dredge or a power shovel.
- Check the clamshell watertightness throughout the operations.
- Check the barge compartment watertightness throughout the operations.
- Do not overload the barge or use it during harsh weather conditions.
- Limit the speed of the dredge and the barge in shallow water.
- Do not overload the embankment or the area close to shore so as to reduce the risk of land slip or sediment stripping.

Notes

- The dredging effects will be temporary.
- The disturbance of fish biological functions will be temporary and limited to the period of work.
- The fish are able to move away from the disturbed areas.
- In general, fish can tolerate high SS concentrations (Rieussec, 2008) or avoid areas with high SS concentrations.
- The design retained for the port infrastructures minimizes encroachment on the aquatic setting.
- The loss of fish habitat by encroachment is permanent. A compensation project will be implemented that meets the requirements of Fisheries and Oceans Canada (Section 8.6).
- The cell protective stone ballast will create new fish habitats (approximate surface area of 9,260 m²).

Significance of the residual effect: Not significant

Follow-up (Section 9)

- A follow-up will be conducted to check the colonization of epibenthos on the protective stone ballast.

Data sheet PI-10

Environmental components

Marine mammals/Species with special status

Ecosystemic value: Large

Important element of the marine trophic chain. Some species have been designated as species at risk.

Sociocultural and economic value: Large

Numerous species of marine mammals represent a source of food and income source for the Inuit. Hunting is an integral part of their way of life (GENIVAR, 2007b). The ecological service rendered by a coastal ecosystem in terms of providing food is evaluated at \$7,549/ha/year (Kumar, 2010).

Sources of the effect

Phases: Construction/Modification

Activities: Dredging/Work related to the construction of the port infrastructures

Description of the potential effects		
<ul style="list-style-type: none"> Implementation of the work risks disturbing the marine mammals by undersea noise (Richardson <i>et al.</i>, 1995; Ford, 1977 in Richardson <i>et al.</i>, 1995; and Fraker, 1977 in Richardson <i>et al.</i>, 1995). Several observers have noted that belugas reacted less to a stationary dredge than to the movement of barges for transporting sediment. However, DESSAU Inc. (2010b) mentions the presence of belugas at 20 m from the clamshell dredge in Rivière-du-Loup, which caused a complete halt of work for 30 minutes. The sectorial report <i>Caractérisation de l'environnement sonore sous-marin de la baie Déception</i> [Characterization of the undersea noise environment in Deception Bay] (GENIVAR, 2012b) (Appendix 10) covers the effects of higher noise levels on marine mammals. The increases in SS concentrations could disturb marine mammals. There is a risk of collision between the dredge or barges and marine mammals. 		
Degree of disturbance: High	Intensity of the effect: High	Duration of the effect: Temporary
Duration-intensity index: High	Scope of the effect: Local	
Significance of the effect: Average		
Attenuation measures/Monitoring		
<u>Dredging</u>		
<ul style="list-style-type: none"> Ensure the mandatory presence of qualified marine mammal monitors on the shoreline during dredging work. Commence monitoring at least 30 minutes before the start of work. 		

- Stop the dredging work if there are belugas or other marine mammals present within 400 m of the dredge.

A monitoring report will be produced.

Pile and sheet-pile driving

The following approach is proposed for performing the work independently of conditions conducive to traditional visual monitoring: The work would only be halted during a period when marine mammals or, if applicable, any other animal deemed sensitive, is actually found within a security perimeter of 1,200 m;

- Schedule the noisiest work for after July 15, i.e. during the period when the belugas' essential biological activities are lower;
- Start monitoring for cetaceans at least 30 minutes before the start of blasting work or pile-driving;
- Start the pile-driving operations gradually over a period of 20-30 minutes to enable any cetaceans present to move away from the source of the noise;
- Implement a passive program to monitor for the presence of marine mammals that listens for their sounds using hydrophones or electronic detection using sonar;
- Implement an intensive visual monitoring program from the start of work until a general balance can be established between passive observations (acoustic or sonar) and active observations (visual), which will facilitate subsequent identification of organisms observed passively; then, the visual monitoring equipment would only be used to confirm "ambiguous" passive observations;
- Implement, from the start of work, an acoustic monitoring program for noise emitted by the site activities, in order to define in real time the security perimeter (threshold of 160 dB re 1 µParms), modulate the functioning of site equipment and thus limit the emission of potentially disturbing noise, and assess the actual need to use additional attenuation measures (bubble screen, Styrofoam sheathing, etc.).

A monitoring report will be produced.

Notes

Significance of the residual effect: Not significant

Follow-up

- A follow-up is not necessary.

Data sheet PI-11

Environmental component

Avian fauna (wildfowl)

Ecosystemic value: Average

Wildfowl play a role in the Arctic trophic chain.

Sociocultural and economic value: Large

Wildfowl represent a food source for the Inuit. Hunting is an integral part of their way of life. The ecological service rendered by a coastal ecosystem in terms of providing food is evaluated at \$7,549/ha/year (Kumar, 2010).

Sources of the effect

Phase: Construction/Modification

Activities: Dredging/Work related to the construction of the port infrastructures

Description of the potential effects		
<ul style="list-style-type: none"> The noise generated by the construction equipment (e.g. the dredge) may constitute a source of disturbance for avian fauna. 		
Degree of disturbance: Low	Intensity of the effect: Average	Duration of the effect: Temporary
Duration-intensity index: Average	Scope of the effect: Occasional	
Significance of the effect: Minor		
Attenuation measures/Monitoring		
<ul style="list-style-type: none"> None 		
Notes		
<ul style="list-style-type: none"> In general, seabirds seem to very quickly become accustomed to the presence of equipment, their comings and goings, and the noise caused by machinery (Environment Canada, 1994). 		
Significance of the residual effect: Not significant		
Follow-up		
<ul style="list-style-type: none"> A follow-up is not necessary. 		

Data sheet PI-12

Environmental component

Ambient noise

Ecosystemic value: N/A

Sociocultural and economic value: Large

Ambient noise includes all noise generated by human activity taking place in Deception Bay. The natural aspect of Deception Bay is sensitive to the noise level (large northern space).

Sources of the effect

Phases: Construction/Operation/Modification

Activities: Dredging/Work related to the construction of the port infrastructures/Ore transshipment

Description of the potential effects <ul style="list-style-type: none"> Increase in noise levels on the periphery of the worksite associated with the operation of heavy machinery, construction equipment, the conveyor system and generator sets, which will add to ambient noise levels. 		
Degree of disturbance: Average	Intensity of the effect: High	Duration of the effect: Temporary
Duration-intensity index: High	Scope of the effect: Local	
Significance of the effect: Average		
Attenuation measures/Monitoring <ul style="list-style-type: none"> The machinery and equipment will be subject to regular scheduled inspections to ensure that the exhaust systems are in good condition, so as to limit noise emissions. The movement of machinery will be restricted to the work areas. When possible, the main noise sources will be insulated with sound absorbent material. All workers subjected to long periods of noise exceeding 85 dB(A) will be obliged to wear hearing protective equipment (provided) at all times. 		
Notes <ul style="list-style-type: none"> The generator sets are installed in soundproof containers. The noise emissions will meet the current standard of 70 dB. 		
Significance of the residual effect: Not significant		
Follow-up <ul style="list-style-type: none"> A follow-up is not necessary. 		

Data sheet PI-13

Environmental component

Economy

Ecosystemic value: N/A

Sociocultural and economic value: Large

Sources of the effect

Phases: Construction/Modification

Activities: Dredging/Work related to the construction of the port infrastructures

Description of the potential effects		
<ul style="list-style-type: none"> Overall, the port infrastructure layout project is likely to have positive economic spinoffs for the Inuit communities through the awarding of contracts to Inuit companies. 		
Degree of disturbance: N/A	Intensity of the effect: N/A	Duration of the effect: N/A
Duration-intensity index: N/A	Scope of the effect: N/A	
Significance of the effect: N/A		
Attenuation measures/Monitoring		
N/A		
Notes		
<ul style="list-style-type: none"> Section 6 of the Nunavik Nickel agreement sets out a framework for the awarding of contracts to Inuit companies working in various fields (transportation, construction, goods and services, etc.). Construction of the port infrastructures is a component of the NNIP included in the agreement. 		
Significance of the residual effect: N/A		
Follow-up		
<ul style="list-style-type: none"> A follow-up is not necessary. 		

Data sheet PI-14

Environmental component

Jobs

Ecosystemic value: N/A

Sociocultural and economic value: Large

Sources of the effect

Phases: Construction/Modification

Activities: Dredging/Work related to the construction of the port infrastructures

Description of the potential effects		
<ul style="list-style-type: none"> Overall, the port infrastructure layout project is likely to create job opportunities for the neighbouring communities (Salluit, Kangiqsujuaq and Puvirnituk) and for the Nunavik Inuit in general. 		
Degree of disturbance: N/A	Intensity of the effect: N/A	Duration of the effect: N/A
Duration-intensity index: N/A	Scope of the effect: N/A	
Significance of the effect: N/A		
Attenuation measures/Monitoring		
N/A		
Notes		
<ul style="list-style-type: none"> Section 5 of the Nunavik Nickel agreement sets out a framework aimed at promoting CRI hiring of Inuit employees for implementation of the NNIP. The agreement also stipulates the establishment of training programs to improve Inuit employability, in cooperation with the Kativik regional administration and the Kativik school board. A program will be set up to orient and inform the Inuit about job possibilities in the mining industry and for the NNIP. During the operation phase, at least five Inuit hired as permanent employees will participate in a training program. The awarding of contracts to Inuit companies will generate jobs. 		
Significance of the residual effect: N/A		
Follow-up		
<ul style="list-style-type: none"> A follow-up is not necessary. 		

Data sheet PI-15

Environmental component

Health

Ecosystemic value: N/A

Sociocultural and economic value: Large

The health and safety of workers and users of the Deception Bay highway is important. Every accident generates costs in materials, intervention time and healthcare.

Sources of the effect

Phases: Construction/Operation/Modification

Activities: Dredging/Work related to the construction of the port infrastructures/Ore transshipment

Description of the potential effects		
<ul style="list-style-type: none"> • Risk of accidents involving workers. • Risk of road collisions. 		
Degree of disturbance: Low	Intensity of the effect: Average	Duration of the effect: Temporary
Duration-intensity index: Average	Scope of the effect: Occasional	
Significance of the effect: Minor		
Attenuation measures/Monitoring		
<ul style="list-style-type: none"> • CRI will implement the occupational health and safety program. • The workers will receive awareness-raising and training sessions regarding health and safety at work. • Suitable highway signage will be erected before the start of the construction work to inform other road users of the increased presence of trucks. • Driving speeds will be limited. • The vehicles and construction equipment will be subject to regular scheduled inspections to ensure they are in good working order. 		
Notes		
<ul style="list-style-type: none"> • Every new worker will receive training on the health and safety procedures upon arrival at the work camp. A personal meeting with the nursing staff is mandatory to fill out the worker's "health form." 		
Significance of the residual effect: Not significant		
Follow-up		
<ul style="list-style-type: none"> • A follow-up is not necessary. 		

Data sheet PI-16

Environmental component

Land use by the Inuit for traditional purposes

Ecosystemic value: N/A

Sociocultural and economic value: Large

Exploitation of the flora and fauna is a crucial activity for the Inuit population and Deception Bay is an essential subsistence area for the Salluit Inuit (ARK, 1998). The communities' way of life, culture and economy are focused on hunting, fishing and trapping. From an economic viewpoint, the products from exploiting the flora and fauna help meet the communities' needs.

Sources of the effect

Phase: Construction

Activities: Dredging/Work related to the construction of the port infrastructures

Description of the potential effects		
<ul style="list-style-type: none"> Possible disruption of the Inuit's flora and fauna exploitation activities. Loss of subsistence areas. 		
Degree of disturbance: Average	Intensity of the effect: High	Duration of the effect: Temporary
Duration-intensity index: High	Scope of the effect: Occasional	
Significance of the effect: Average		
Attenuation measures/Monitoring		
<ul style="list-style-type: none"> To minimize disruption in their traditional activities, the Inuit will be informed of the implementation and period of work. 		
Notes		
<ul style="list-style-type: none"> The sector affected by the port infrastructures is small in size and not intensively exploited by the Inuit. The design retained minimizes encroachment on the aquatic setting and the consequences on aquatic resources. 		
Significance of the residual effect: Not significant		
Follow-up		
<ul style="list-style-type: none"> A follow-up is not necessary. 		

Data sheet PI-17

Environmental component

Navigation

Ecosystemic value: N/A

Sociocultural and economic value: Large

Commercial shipping is a very important factor in remote areas, especially for the provision of equipment, healthcare and sea rescue operations. Deception Bay is a hub for the movement of ore from mines currently being worked in the region. The Inuit use the Bay to move around, and to exploit its fauna resources.

Sources of the effect

Phases: Construction/Modification

Activities: Dredging/Navigation

Description of the potential effects		
<ul style="list-style-type: none"> Risk of accident (collisions) at the port infrastructure site due to the presence of the dredge and barges. 		
Degree of disturbance: Low	Intensity of the effect: Average	Duration of the effect: Temporary
Duration-intensity index: Average	Scope of the effect: Occasional	
Significance of the effect: Minor		
Attenuation measures/Monitoring		
<ul style="list-style-type: none"> Notify shipping and users of Deception Bay of the port infrastructure construction schedule. Maintain a shipping exclusion zone of 500 m around the work sector. 		
Notes		
Significance of the residual effect: Not significant		
Follow-up		
<ul style="list-style-type: none"> A follow-up is not necessary. 		

Data sheet PI-18

Environmental component

Landscape

Ecosystemic value: N/A

Sociocultural and economic value: Large

Sources of the effect

Phases: Construction/Operation

Activities: N/A

Description of the potential effects		
<ul style="list-style-type: none"> The presence of port infrastructures alters the landscape of Deception Bay. 		
Degree of disturbance: Average	Intensity of the effect: High	Duration of the effect: Permanent
Duration-intensity index: High	Scope of the effect: Occasional	
Significance of the effect: Average		
Attenuation measures/Monitoring		
<ul style="list-style-type: none"> Respect the natural topography of the landscape by not dumping materials outside the industrial sector. 		
Notes		
<ul style="list-style-type: none"> The port infrastructures will be integrated into a landscape unit defined as an industrial sector. 		
Significance of the residual effect: Not significant		
Follow-up		
A follow-up is not necessary.		

Data sheet PI-19

Environmental component

Marine mammals and species with special status

Ecosystemic value: Large

Several species of marine mammals, some of which have special status, can be found in Deception Bay. These animals perform several biological functions in the Bay, including feeding and resting. Seals calve, raise their young and moult on the ice during the spring.

Sociocultural and economic value: Large

The Inuit hunt the marine mammals for food and clothing.

Source of the effect

Phase: Operation

Activity: Navigation

Description of the potential effects		
<ul style="list-style-type: none"> • Disruption due to the increased level in undersea noise. • Risk of collisions. • Possible disturbance of habitat essential to the seals through a breakup of the ice cover caused by the movement of ships during the ice period. 		
Degree of disturbance: Average	Intensity of the effect: High	Duration of the effect: Temporary
Duration-intensity index: High	Scope of the effect: Local	
Significance of the effect: Average		
Attenuation measures/Monitoring		
<ul style="list-style-type: none"> • The ships will always use the same route, for entering and leaving, i.e. the same as that used by the Xstrata ships. • A shipping exclusion period extends from mid-March to mid-June to avoid the critical period for seal calving, suckling and raising their young. • The number of ore carrier trips will be limited to three between December 1 and March 15. • The maximum ship speed will not exceed 7 knots. • During the winter, the ships will always use the same channel. This maneuver is intended to reduce the impact on the stability of the ice in Deception Bay. 		
Notes		
<ul style="list-style-type: none"> • The total number of scheduled trips is 22 per year (11 return trips). 		

Significance of the residual effect: Not significant

Follow-up

- A follow-up on shipping in Deception Bay includes the collection of marine mammal observations. This follow-up is required as part of the NNIP authorizations (Section 9).

Data sheet PI-20

Environmental component

Land use by the Inuit for traditional purposes

Ecosystemic value: N/A

Sociocultural and economic value: Large

Deception Bay is deemed to be an essential subsistence area for the Salluit community (ARK, 1998). The Inuit exploit several species of fauna to be found in Deception Bay. In winter, they use a network of snowmobile trails across the Bay to get to their traditional hunting and fishing grounds. Ice stability and strength is important for the safety of these trips.

Source of the effect

Phase: Operation

Activity: Navigation

<p>Description of the potential effects</p> <ul style="list-style-type: none"> • The passage of ships during the ice period can temporarily compromise access to certain hunting and fishing grounds, by breaking up the ice and carving out a channel that cuts the trails used by the snowmobiles. • In spring, shipping could cause an early ice break-up in certain areas of the Bay. • The passage of ships, during the ice period, could disturb the seal habitat, cause some of them to flee and thus reduce the success of Inuit hunting. 		
<p>Degree of disturbance: Average</p>	<p>Intensity of the effect: High</p>	<p>Duration of the effect: Temporary</p>
<p>Duration-intensity index: High</p>	<p>Scope of the effect: Local</p>	
<p>Significance of the effect: Average</p>		
<p>Attenuation measures/Monitoring</p> <ul style="list-style-type: none"> • A shipping exclusion period extends from mid-March to mid-June. • Except in case of emergency stemming from unforeseen, significant events that can only be resolved by sea transportation, no trips will be made during the period between mid-March and mid-June. • The number of ore carrier trips will be limited to three between December 1 and March 15. • The maximum ship speed will not exceed 7 knots. • The ships will follow an "S" shaped route. • The shipping routes will be coordinated with those used by Xstrata. The two companies will exchange shipping schedules. 		

- The ships will always use the same route, for entering and leaving, i.e. the same as that used by the Xstrata ships.
- During the winter, the ships will always use the same channel. This maneuver is intended to reduce the impact on the stability of the ice in Deception Bay.
- Inform the Salluit community in order to reduce the risk related to opening the ice cover, and minimize the potential consequences on hunting and fishing activities. The communication methods will include satellite phone calls to the Salluit hunting and fishing association manager, provision of a shipping schedule to the appropriate Salluit authorities and access to a link on the Canadian Royalties website.
- Maintain, as needed, a second ice bridge further upstream, at Pointe-Noire, that will greatly reduce the detour for snowmobilers. This bridge will be maintained by qualified Inuit personnel. Signage panels will be erected to identify the area before and after the ice bridge.

Notes

- The anticipated effects will be infrequent and of short duration.
- From January to April, the ice cover in Deception Bay takes approximately three hours to reform after the passage of a ship (Don Cameron, Nuvumiut Developments Inc., pers. comm., 2006; Tom Paterson, FEDNAV shipping line, pers. comm., 2006.)

Significance of the residual effect: Not significant

Follow-up

- A follow-up on shipping in Deception Bay addresses the issue of traditional Inuit activities. This follow-up is required as part of the NNIP authorizations (Section 9).

Data sheet PI-21

Environmental component

Navigation

Ecosystemic value: N/A

Sociocultural and economic value: Large

Commercial shipping is a very important factor in remote areas, specifically for re-supply. Deception Bay is a transit hub for ore from mines currently being worked in the region. The Inuit use the Bay to move around, and to exploit its fauna resources.

Sources of the effect

Phases: Operation

Activity: Navigation

Description of the potential effects		
<ul style="list-style-type: none"> Risk of accident (collisions) at the port infrastructure site and in Deception Bay during the passage of ore carriers, cargo ships and oil tankers. 		
Degree of disturbance: Low	Intensity of the effect: Average	Duration of the effect: Temporary
Duration-intensity index: Average	Scope of the effect: Occasional	
Significance of the effect: Minor		
Attenuation measures/Monitoring		
<ul style="list-style-type: none"> Issue warnings to shipping and inform the Salluit Inuit of planned ship movements to ensure the safety of other shipping. The maximum ship speed will not exceed 7 knots. 		
Notes		
Significance of the residual effect: Not significant		
Follow-up		
<ul style="list-style-type: none"> A follow-up is not necessary. 		

8.2.2 Sediment dump

During the construction phase, the sources of effects include the transportation of excavated earth, formation of the dump and layout of the runoff and decantation water collection ditch network.

In the operation phase, the sources of effects include the transportation of dredged sediment to the dump and placement on the dump.

The sediment dump will be laid out directly on the shot rock dump from the blasting work conducted at the concentrate hall site. No enlargement or additional encroachment into the natural surroundings, thereby significantly limiting the potential effects on the various components of the land environment. The current access will be used.

No effect is anticipated during the layout of the land dump site on the soil, land vegetation, species with special status or archaeological heritage of the adjacent setting. Similarly, aside from the disturbance caused by the work and the risk of collision during the transportation of sediment, no impact is anticipated on the land mammals and avian fauna.

Table 8.6 shows the relationship between the potential effects of the land sediment dump in the various project components and those of the environment. The assessment forms can be found on the following pages.

Table 8.6 Identification of potential effects matrix of the land sediment dump.

Nature of potential impacts DT-x / □ Negative impact DT-x / ■ Positive impact	Sources of potential effects						
	Construction	Operation			Modification*	Decommissioning and closure	
		Layout of the dump site	Transportation of sediment	Dumping			Maintenance
Physical and biological settings	Surface water quality	DT-1	-	DT-1	-	DT-1	■
	Air quality		DT-2		-	DT-2	□ / ■
	Land mammals		DT-3		-	DT-3	■
	Avian fauna (land)		DT-4		-	DT-4	■
Human setting	Ambient noise		DT-5		-	DT-5	■
	Health		DT-6		-	DT-6	
	Economy		DT-7		-	DT-7	
	Jobs		DT-8		-	DT-8	
	Landscape		DT-9		-	DT-9	

* According to the type of modifications. The same impacts as those expected in the construction phase are likely to occur in the modification phase, since the same activities and work are likely to be performed.

Data sheet DT-1

Environmental component

Surface water quality

Ecosystemic value: Large

Quality surface water will ensure optimal conditions for flora and fauna development.

Sociocultural and economic values: N/A

Sources of the effect

Phases: Construction/Operation/Modification

Activities: Layout of the dump site/Dumping of the dredged sediment

Description of the potential effects <ul style="list-style-type: none"> • Contamination of surface water by hydrocarbons (construction equipment and trucks). • The water contained in the dredged sediment could contaminate land surface water with a lower salinity than that contained in the sediment. • Concentration of SS at the decantation water discharge point higher than the established criterion. 		
Degree of disturbance: Low	Intensity of the effect: Average	Duration of the effect: Temporary
Duration-intensity index: Average	Scope of the effect: Occasional	
Significance of the effect: Minor		
Attenuation measures/Monitoring <ul style="list-style-type: none"> • A network of ditches will be laid out around the dump to capture and redirect the runoff and decantation water to the existing ditches. The water will be returned via the latter to Deception Bay. • A sediment barrier will be installed in a gap created directly in the dump berm to capture fine particles. • Various sampling points will make it possible to take samples for surface water quality analyses. 		
Notes		
Significance of the residual effect: Not significant		
Follow-up A follow-up will be conducted (Section 9).		

Data sheet DT-2

Environmental component

Air quality

Ecosystemic value: N/A

Sociocultural and economic value: Large

Air quality is an element deemed to be important since the work will be conducted in a natural setting relatively undisturbed by human activity.

Sources of the effect

Phases: Construction/Operation/Modification

Activities: Layout of the dump site/Transportation and dumping of the dredged sediment

Description of the potential effects		
<ul style="list-style-type: none"> Emission of atmospheric pollutants and dust from the movement of trucks and the operation of heavy machinery and construction equipment. 		
Degree of disturbance: Average	Intensity of the effect: High	Duration of the effect: Temporary
Duration-intensity index: High	Scope of the effect: Local	
Significance of the effect: Average		
Attenuation measures/Monitoring		
<ul style="list-style-type: none"> Standard measures 12 to 17. Use of Arctic diesel. 		
Notes		
<ul style="list-style-type: none"> 		
Significance of the residual effect: Not significant		
Follow-up		
A follow-up is not necessary.		

Data sheet DT-3

Environmental component

Land mammals

Ecosystemic value: Average

Sociocultural and economic value: Large

Some species of land mammals represent a source of food and income for the Inuit. Hunting is an integral part of their way of life.

Sources of the effect

Phases: Construction/Operation/Modification

Activities: Dump site layout/Transportation of sediment

Description of the potential effects <ul style="list-style-type: none"> The noise generated by the construction equipment (e.g. the dredge) may constitute a source of disturbance for land mammals. Risk of collisions. 		
Degree of disturbance: Low	Intensity of the effect: Average	Duration of the effect: Temporary
Duration-intensity index: Average	Scope of the effect: Local	
Significance of the effect: Average		
Attenuation measures/Monitoring <ul style="list-style-type: none"> Accurately define the work areas. The movement of machinery will be restricted to the work areas. Dump truck speeds will be limited. 		
Notes <ul style="list-style-type: none"> The sediment will be dumped directly above the existing excavated earth dump. No enlargement or additional encroachment is planned in the surrounding area, thereby eliminating the risk of habitat being destroyed. 		
Significance of the residual effect: Not significant		
Follow-up A follow-up is not necessary.		

Data sheet DT-4

Environmental component

Avian fauna

Ecosystemic value: Average

Sociocultural and economic value: Low

Limited interest and use by the Inuit.

Sources of the effect

Phase: Construction/Modification

Activity: Layout of the dump site

<p>Description of the potential effects</p> <ul style="list-style-type: none"> • The noise generated by the construction equipment (e.g. the dredge) may constitute a source of disturbance for avian fauna. • The encroachment of the dump into the natural setting could destroy habitat and nests. 		
<p>Degree of disturbance: Low</p>	<p>Intensity of the effect: Average</p>	<p>Duration of the effect: Temporary</p>
<p>Duration-intensity index: Average</p>	<p>Scope of the effect: Occasional</p>	
<p>Significance of the effect: Minor</p>		
<p>Attenuation measures/Monitoring</p> <ul style="list-style-type: none"> • Accurately define the work areas. • The movement of machinery will be restricted to the work areas. 		
<p>Notes</p> <ul style="list-style-type: none"> • The sediment will be dumped directly on the shot rock from the blasting work at the ore concentrate hall site. No enlargement or additional encroachment is planned in the surrounding area, thereby eliminating the risk of habitat or nests being destroyed. 		
<p>Significance of the residual effect: Not significant</p>		
<p>Follow-up A follow-up is not necessary.</p>		

Data sheet DT-5

Environmental component

Ambient noise

Ecosystemic value: N/A

Sociocultural and economic value: Large

Ambient noise includes all noise generated by human activity taking place in Deception Bay. The natural aspect of Deception Bay is sensitive to the noise level (large northern space)

Sources of the effect

Phases: Construction/Operation/Modification

Activities: Layout of the dump site/Transportation and dumping of the dredged sediment

Description of the potential effects		
<ul style="list-style-type: none"> Increase in noise levels on the periphery of the worksite associated with the operation of heavy machinery and construction equipment, which will add to ambient noise levels. 		
Degree of disturbance: Average	Intensity of the effect: High	Duration of the effect: Temporary
Duration-intensity index: High	Scope of the effect: Local	
Significance of the effect: Average		
Attenuation measures/Monitoring		
<ul style="list-style-type: none"> The machinery and equipment will be subject to regular scheduled inspections to ensure that the exhaust systems are in good condition, so as to limit noise emissions. The movement of machinery will be restricted to the work areas. When possible, the main noise sources will be insulated with sound absorbent material. All workers subjected to long periods of noise exceeding 85 dB(A) will be obliged to wear hearing protective equipment (provided) at all times. 		
Notes		
Significance of the residual effect: Not significant		
Follow-up		
A follow-up is not necessary.		

Data sheet DT-6

Environmental component

Health

Ecosystemic value: N/A

Sociocultural and economic value: Large

The health and safety of workers and users of the Deception Bay highway is important. Every accident generates costs in materials, intervention time and healthcare.

Sources of the effect

Phases: Construction/Operation/Modification

Activities: Layout of the dump site/Transportation and dumping of the dredged sediment

Description of the potential effects <ul style="list-style-type: none"> • Risk of accidents involving workers. • Risk of road collisions. 		
Degree of disturbance: Low	Intensity of the effect: Average	Duration of the effect: Temporary
Duration-intensity index: Average	Scope of the effect: Local	
Significance of the effect: Average		
Attenuation measures/Monitoring <ul style="list-style-type: none"> • The occupational health and safety program will be implemented. • The workers will receive awareness-raising and training sessions regarding health and safety at work. • Erection of suitable highway signage before the start of construction work to inform other road users of the increased presence of trucks. • Truck speeds will be limited. • The vehicles and construction equipment will be subject to regular scheduled inspections to ensure they are in good working order. 		
Notes <ul style="list-style-type: none"> • Every new worker will receive training on the health and safety procedures upon arrival at the work camp. A personal meeting with the nursing staff is mandatory to fill out the worker's "health form." 		
Significance of the residual effect: Not significant		
Follow-up A follow-up is not necessary.		

Data sheet DT-7

Environmental component

Economy

Ecosystemic value: N/A

Sociocultural and economic value: Large

Sources of the effect

Phases: Construction/Operation/Modification

Activities: Layout of the dump site/Transportation and dumping of the dredged sediment

Description of the potential effects		
<ul style="list-style-type: none"> Overall, the port infrastructure layout project is likely to have positive economic spinoffs for the Inuit communities through the awarding of contracts to Inuit companies. 		
Degree of disturbance: N/A	Intensity of the effect: N/A	Duration of the effect: N/A
Duration-intensity index: N/A	Scope of the effect: N/A	
Significance of the effect: N/A		
Attenuation measures/Monitoring		
N/A		
Notes		
<ul style="list-style-type: none"> Section 6 of the Nunavik Nickel agreement sets out a framework for the awarding of contracts to Inuit companies working in various fields (transportation, construction, goods and services, etc.). Construction of the port infrastructures is a component of the NNIP included in the agreement. 		
Significance of the residual effect: N/A		
Follow-up		
A follow-up is not necessary.		

Data sheet DT-8

Environmental component

Labour

Ecosystemic value: N/A

Sociocultural and economic value: Large

Sources of the effect

Phases: Construction/Operation/Modification

Activities: Layout of the dump site/Transportation and dumping of the dredged sediment

Description of the potential effects		
<ul style="list-style-type: none"> Overall, the port infrastructure layout project is likely to create job opportunities for the neighbouring communities (Salluit, Kangiqsujuaq and Puvirnituk) and for the Nunavik Inuit in general. 		
Degree of disturbance: N/A	Intensity of the effect: N/A	Duration of the effect: N/A
Duration-intensity index: N/A	Scope of the effect: N/A	
Significance of the effect: N/A		
Attenuation measures/Monitoring		
N/A		
Notes		
<ul style="list-style-type: none"> Section 5 of the Nunavik Nickel agreement sets out a framework aimed at promoting the CRI hiring of Inuit employees for implementation of the project. The agreement also stipulates the establishment of training programs to improve Inuit employability, in cooperation with the Kativik regional administration and the Kativik school board. The awarding of contracts to Inuit companies will generate jobs. 		
Significance of the residual effect: N/A		
Follow-up		
A follow-up is not necessary.		

Data sheet DT-9

Environmental component

Landscape

Ecosystemic value: N/A

Sociocultural and economic value: Large

Sources of the effect

Phases: Construction/Operation

Activities: N/A

Description of the potential effects		
<ul style="list-style-type: none"> The presence of the sediment dump could alter the landscape of Deception Bay. 		
Degree of disturbance: Low	Intensity of the effect: High	Duration of the effect: Permanent
Duration-intensity index: High	Scope of the effect: Occasional	
Significance of the effect: Average		
Attenuation measures/Monitoring		
<ul style="list-style-type: none"> Respect the natural topography of the landscape by not dumping materials outside the industrial sector. 		
Notes		
<ul style="list-style-type: none"> The sediment will be dumped directly on the existing shot rock dump located in a landscape unit defined as an industrial sector. 		
Significance of the residual effect: Not significant		
Follow-up		
A follow-up is not necessary.		

8.3 Principal issues

In this project, two issues require close attention due to the sensitivity and value of the environmental components affected. To be chosen as a valued environmental component (VEC), an environmental component must:

- Be highly valued by the populations involved or specialists
- Be likely to be changed or affected by the project

The selected VECs are marine mammals and traditional land use by the Inuit.

8.3.1 Marine Mammals

Several species of mammal use Deception Bay and carry out a number of critical biological functions there (parturition, suckling, raising offspring, etc.) (section 6.2.1.4). A few of these species have a special status due to such things as reduced population numbers, or habitat scarcity or fragility. These include the beluga and bowhead whale. Human activity that disrupts, changes or destroys these mammals' habitats could put additional pressure on their survival.

The project's impacts on marine mammals will primarily be felt during construction, when dredging is performed and the piles for the two wharf cells are inserted using vibration drilling and driving. These activities increase underwater noise levels. The work period overlaps the summer season, a period of intense beluga use of Deception Bay, for feeding, raising offspring, moulting and rest of juveniles, biological activities that are essential to survival.

Two sector reports describe the project's potential impacts on marine mammals. The first (GENIVAR, 2012B; Appendix 10) sets out the hydroacoustical data gathered in the summer of 2012 and describes Deception Bay's sound environment., The report also sets out the known effects of noise from drilling activities on marine mammals and fish, and their sensitivity to this phenomenon. Lastly, it describes an exclusion zone and puts forward a marine mammal monitoring strategy to minimize the effects on these animals of the noise generated by the work.

The report states that the distance required to get the noise pressure below established safety thresholds is equivalent to noise pressures of 160 dB re 1 $\mu\text{Pa}_{\text{rms}}$ for cetaceans (a group to which the beluga belongs) and 180 dB re 1 $\mu\text{Pa}_{\text{rms}}$ for pinnipeds (seals). - Above these thresholds, physiological damage may occur if individuals are exposed to these noise levels. Below these levels, the impacts are limited to behavioural changes.

The second report (GENIVAR, 2007, Appendix 22) reports potential effects from navigation on marine mammals that use Deception Bay. It assesses the effects and proposes mitigation measures.

The ensuing discussion is based on these two reports.

8.3.1.1 Dredging

Dredging generates noise of average intensity (noise pressure at the source of 150 to 162 dB re 1 μ Pa) over relatively long periods (16 hours/day). Dredging work is expected to last about 30 days.

The increased noise level around the dredging zone could disrupt the flow of the beluga's biological activities, make them avoid the noisy area or adjust their vocalizations, without causing harmful physiological effects or hearing loss to the beluga. The beluga could also collide with the dredge or barges during manoeuvres or travel.

A 400 m exclusion zone will be established around the dredging area to reduce the risks of such occurrences (map 8.1). A qualified monitoring person on the shoreline will handle detection of the presence of belugas or any other marine mammal. As soon as one or more mammals are spotted within this 400 m radius, work will be suspended immediately until they depart. Work will also be suspended during poor weather in which visibility is reduced.

8.3.1.2 Drilling of piles and sheet piles

Source sound pressure for drilling of piles will be around 210 dB re 1 μ Pa_{rms}. At this pressure, according to the sound mitigation measures carried out in Deception Bay in 2012, an exclusion zone of 1,200 m is prescribed. Within the zone, as mentioned above, safety thresholds for cetaceans and seals are exceeded. Marine mammals present during the work could be subject to physiological damage.

To provide for maximum protection of belugas likely to be in the work sector, the DFO has prescribed an exclusion period for work involving the propagation of underwater noise; it runs from June 20 to July 15 inclusively (GENIVAR, 2008b). However, this does not cover dredging and backfilling. The exclusion period will be respected.



Moosehead Islands

74°40'0"W



Carte 8.1 / Map 8.1

Zones de surveillance des mammifères marins proposées / Proposed Marine Mammal Monitoring Area

0 0,5 1 1,5 km

Projection : UTM, zone 18, NAD83
Equidistance des courbes / Contour Interval : 50 pieds / feet

Source :

Base : BNDT, 1 : 50 000, 1976 à 1995**, © Sa Majesté la Reine du Chef du Canada, reproduit avec la permission de RNCan

Inventaires et cartographie / Surveys and mapping : GENIVAR
Fichier / File : 101_53046_EIES_BD_c8_1_surveil_121120.mxd

Novembre / November 2012



101-53046-02

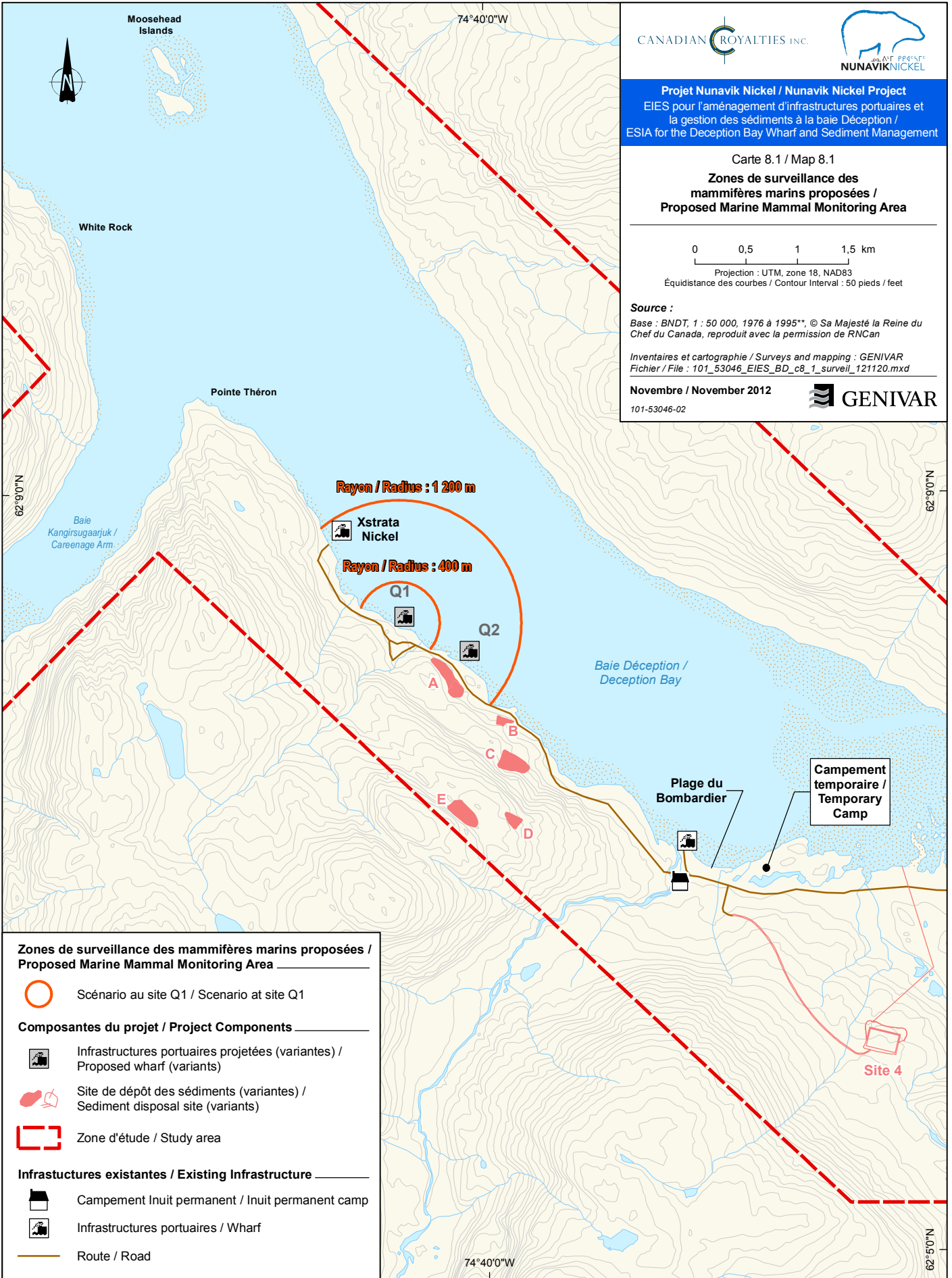

Zones de surveillance des mammifères marins proposées / Proposed Marine Mammal Monitoring Area

Scénario au site Q1 / Scenario at site Q1

Composantes du projet / Project Components

Infrastructures portuaires projetées (variantes) / Proposed wharf (variants)

Site de dépôt des sédiments (variantes) / Sediment disposal site (variants)

Zone d'étude / Study area

Infrastructures existantes / Existing Infrastructure

Campement Inuit permanent / Inuit permanent camp

Infrastructures portuaires / Wharf

Route / Road

74°40'0"W

62°50'0"N

During drilling work, marine mammals will be monitored over the 1,200 m exclusion zone. An optimized monitoring strategy will be implemented to allow work to be done whether or not conditions are conducive to traditional visual monitoring. Work would only be interrupted during the period in which marine mammals or, if applicable, any other sensitive animals are actually within the 1,200 m safety perimeter. The strategy is based on the following:

- Start monitoring cetaceans at least 30 minutes before the onset of drilling work.
- Start drilling operations gradually and continuously over a period of 20 to 30 minutes to allow any cetaceans in the area to move away from the noise source.
- Institute a passive marine mammal monitoring program that uses hydrophones to listen for their sounds and electronic detection using sonar.
- Institute an intensive visual monitoring program as of the onset of work, so as to establish a general match between passive observations (acoustic and sonar) and active observations (visual), which would then facilitate the identification of passively observed organisms. Subsequently, visual monitoring equipment would only be used to validate "ambiguous" passive observations.
- As soon as work begins, set up an acoustic monitoring program for noise emitted by site activities so as to obtain a real-time definition of the safety perimeter (threshold of 160 dB re 1 μ Parms), moderate how site equipment operates so as to limit the emission of potentially disturbing noise, and assess the real need to resort to additional mitigation measures.

Any incident or event involving a marine mammal that occurs during dredging or drilling work will be reported immediately to the site supervisor and CRI environment officer. They will make the necessary adjustments to keep such an incident or event from recurring.

By applying the mitigation and monitoring measures recommended above, the residual effects of the construction of port infrastructures on marine mammals should not be substantial.

8.3.1.3 Navigation

At most 11 trips a year will be needed to ensure NNiP operations run smoothly. As stated in section 7.3, the navigation season will run from June 15 to March 15, with a maximum of three trips between December 1 and March 15. In all, about 80 hours of navigation per year will be done on behalf of CRI. Ships travelling in Deception Bay will be limited to a maximum speed of 7 knots.

Ship travel in the bay is likely to cause three types of impacts on marine mammals: disturbance due to the noise emitted by props and engines, collisions with marine mammals and disruption of seal calving habitat.

Noise

Noise emitted by ships is primarily likely to affect echolocation and communication among individuals, and can become a real source of disturbance if the individuals are subject to long or intense exposure (i.e., by several ships at the same time in the same sector). Marine traffic associated with the NNiP will slightly increase the frequency of disturbances to marine mammals' echolocation and communication, and to their biological activities. However, given the small number of ships and their speed limit, the disturbance will be minor and short, therefore not important.

Fragmentation of ice cover

Ships transiting during the ice cover period break the ice by chewing it up or fragmenting it. This impact is greater in the spring, when it takes longer for ice to reform. Ongoing ice cover is essential for the ringed seal, which uses the ice cover as a habitat for calving, nursing and weaning newborns, moulting and pupping. No ship will transit from March 15 to June 15, the critical period for these activities, and only three trips are slated for the winter period. Moreover, ships will use the same track as Xstrata ships, keeping the ice from being chewed up over overly large expanses. The measures will limit the impact of ship travel on the bay's ice cover.

Collisions

There is a risk of collision between ships and marine mammals. The risk is greater during the open water period, as more marine mammal species may use the bay. It is recognized that most serious or fatal injuries are caused by ships at least 80 m long, which makes them less manoeuvrable, or ships moving at a speed of at least 14 knots (Laist et al. 2001). Usually, it is the most streamlined marine mammals, like rorqual whales, that are hit by a ship's bow (GENIVAR, 2007b). For seals, collisions are more likely during the winter at the entrance to Deception Bay, in areas with uneven ice, where ringed seals prefer to make their dens.

Ships using Deception Bay will move at a maximum speed of 7 knots during the open water period, substantially reducing the risk of collisions. Collisions will also be reduced for the ringed seal given the restriction period, which runs from March 15 to June 15. Ships will use the same track as Xstrata ships, keeping the collision risk from extending to a greater area. These measures seem to have proven their effectiveness, as no mention of a collision has been recorded to date in Deception Bay after fifteen years of marine activity in the Raglan project.

8.3.1.4 Inuit use of the land for traditional purposes

Deception Bay is used intensively by Salluit Inuit, who engage in hunting and fishing throughout the year (GENIVAR, 2007b). They hunt seal, beluga and, more rarely, walrus, and fish for several species, including Arctic char. During the winter, they gather blue mussel.

Transiting ships during the ice-up could temporarily compromise access to some hunting and fishing grounds, by cutting a trench that would intersect snowmobile trails. Moreover, the passage of ships can change the natural dynamic of ice fracturing, triggering early breakup of the ice cover during the melt period. Note, however, that only three trips are slated for the winter period. In the open water period, the impacts of navigation on traditional Inuit activities are limited to noise and temporary disturbance of the wildlife.

Several mitigation measures are planned to minimize the impact on Inuit travel. The measures are contained in the Nunavik Nickel agreement, or were imposed in the context of the NNiP authorization certificate issued by the MDDEP. For example, marine transportation will be prohibited from March 15 to June 15 so as not to impede Inuit hunting activities and avoid disturbing the seals that are on the ice. During this period, trips could be necessary in emergency situations and, if necessary, an agreement would be reached with the Inuit. The mitigation measures also include, if necessary, maintenance of a second ice bridge at the Pointe-Noire level. Maintenance would be performed by qualified Inuit staff. Signage panels would be installed.

CRI also plans to set up a protocol for warning of ice breaker travel in Deception Bay, to minimize the risks to the safety of snowmobilers. The protocol will factor in the condition of the ice cover in Deception Bay and time needed for it to reform (about three hours from January to April; Don Cameron, Nuvumiut Developments Inc., pers. comm, 2006; Tom Paterson, FEDNAV owner, pers. comm., 2006).

Given that traditional activities can continue even during ship travel in Deception Bay, that the main nuisance is associated with a temporary cut in some snowmobile trails between December and mid-March, and given the mitigation measures to be implemented, the impact of navigation on use of the territory for traditional purposes are deemed to be minor.

Moreover, the activities to build port infrastructures and dispose of sediment, the operation of the facilities and navigation are unlikely to reduce the abundance of the main animal resources that the Inuit hunt and fish, whether beluga, seals, Arctic char

or caribou. With the proposed mitigation measures, the project is unlikely to affect or significantly disrupt these animals' essential biological activities or their habitats. According to testimony, Raglan mine transportation activities in Deception Bay do not seem to be creating any substantial impact on the wildlife in the bay.

All in all, the project is not likely to have major negative impacts on the flow of traditional Inuit activities.

Finally, note that NNIP nuisances, including marine activities on Inuit hunting and fishing, will be offset by the sharing of NNIP benefits stipulated in the Nunavik Nickel agreement.

8.4 Fish habitat

The two sheet piling cells and their protective ballast will modify fish habitat. About 1,430 m² of these structures will be above the HHWMT height¹⁴: 940 m² for the two cells and 480 m² for the ballast of casing 2 (south) (table 8.7). Moreover, the total surface area of ballast below the HHWMT height (in the tidal range) is estimated at about 9,260 m², to all practical surfaces equivalent to the dredged area (9,350 m²).

The ballasts should be colonized by aquatic vegetation and epibenthos, create feeding habitats for fish and form shelters from predation or rest areas, thanks to the interstices between the rocks. Moreover, these habitats (on a hard substrate) will enrich and diversify Deception Bay's ecosystem, which is dominated by soft bottom habitats, by attracting organisms that prefer this type of habitat.

Follow-up will be done to check that the ballasts are in fact creating fish habitats (section 9).

Table 8.7 Surface areas of affected fish habitat

Surface area (m ²)	Casing 1	Casing 2	Total
Dredging (footprint)	4,675	4,675	9,350
Casing (footprint)	470	470	940 (A)
Ballast above high high water mean tide (HHWMT) (4.9m)	0	480	480 (B)
Ballast: below lower low water large tide (LLWLT)	5,375	1,635	7,010 (C)
Ballast: between HHWMT and LLWLT	0	2,250	2,250 (D)
Summary m²			
Destruction (A + B)	1 430		
Potential habitat below HHWMT	9.260		

¹⁴ Higher high water mean tide.

Under section 35(2) of the Fisheries Act (R.S.C., 1985, c. F-14), destruction of fish habitat is subject to authorization. CRI will take the required steps to obtain authorization.

8.5 Environmental impacts on the project

This section briefly deals with potential environmental effects on the project. Natural events could jeopardize the integrity of port infrastructures.

8.5.1 Earthquakes

The Deception Bay sector is in an area with low level seismic activity (section 6.1.3.3). Port infrastructures, especially the cells, meet the design criteria for earthquake resistance. An earthquake is unlikely to jeopardize the integrity of the infrastructures.

8.5.2 Ice

Port infrastructures, particularly cells and ballast, will be subject to ice pressure. Facility design has factored in the forces of the ice (section 7.1.8). A stability study was done factoring in the thrust of the ice so as to assess the risks of creep toward the shore. The safety factors calculated for several potential surfaces of rupture are all acceptable.

8.5.3 Avalanche

Dry snow and wet snow (slushflow) avalanches are particularly active in the Deception Bay area (section 6.1.2.3). Slushflows are more erosive and have a very high capacity for transporting sediment, as shown by the 2005 avalanche close to the Xstrata facilities (6.1.2.3). Site Q1 is adjacent to a slushflow corridor, just back (to the northwest) of the avalanche's trajectory. However, depending on the event's magnitude, the alluvial fan could reach Q1 and jeopardize the physical integrity of port infrastructures. The size and behaviour of an alluvial fan are impossible to predict. To minimize any slushflow damage, a deflector will be built and positioned to redirect the snow and sediment (map 7.2).

Dry snow avalanches, which are much less destructive, are not likely to jeopardize infrastructure integrity. No risk corridor is next to Q1.

8.6 Cumulative effects

8.6.1 Legal framework and general

The method for evaluating the project's cumulative effects draws on the method recommended in the Canadian Environmental Assessment Agency's Cumulative Effects Assessment Practitioners' Guide (Hegmann et al., 1999). As shown in this guide, the concept of cumulative effects refers to the possibility that the permanent residual effects generated by a project combine with those of prior, present or future projects or interventions in the same sector or close by to produce greater impacts on the receiving environment.

8.6.2 Scope of the study

8.6.2.1 Study area and period covered

The study area selected for the analysis of cumulative effects is Deception Bay and its shores (map 3.1). The period covers 1995 to 2030. The period runs from the return to port activities at the Xstrata wharf for Raglan mine construction work to the end of work to shut down the Expo mining complex, about two years after the end to mining operations, scheduled for 2028.

8.6.2.2 Valued environmental components

The VECs selected for analysis of the cumulative effects are marine mammals, traditional use of the land by the Inuit and fish habitat.

8.6.2.3 Past, present and future activities, projects and events

Table 8.8 provides a list of past, present and future activities, projects and events likely to have affected or to affect VECs in the study area. The future activities, projects and events are either planned or likely. The land-based sediment deposit is not included in the cumulative effects study, as it will be built within an existing rock deposit and in no way further encroach on the natural environment.

Table 8.8 also identifies the most likely effects that actions, projects and events may have caused to VECs.

Table 8.8 Summary of present and future activities, projects and events likely to have affected or affect VECs

Activity, project, event	VECs and potential effects			Inuit use of the land for traditional purposes
	Past	Present	Future	
Existing port infrastructures (Xstrata, Plage du Bombardier)	x	x	x	Loss of a potential shellfish harvesting area
Canadian Royalties Inc.* port infrastructures		x	x	Loss of a potential shellfish harvesting area
Circulation of large ships in Deception Bay (bulk ore, bulk oil, freight)	x	x	x	Fragmentation / modification of ice cover Increase in noise level: disturbance, disruption of some biological activities and social behaviours Collisions
Circulation of small ships in Deception Bay (zodiacs, launches, fishing and scientific survey boats)	x	x	x	Disturbance Collisions
Climate change -- Changes to the ice regime and increased warming in the bay's waters		x	x	Changes to habitat conditions Access to food resources Changes to habitat conditions Access to traditional hunting and fishing grounds affected/modified**

*Includes operation of the temporary wharf in 2013.

**Source: Tremblay and Furgal, 2008

Xstrata port infrastructures

Potential cumulative effects are likely to be caused by the encroachment of infrastructures into the aquatic environment. Impacts of their construction are no longer being felt.

CRI port infrastructures

Potential cumulative effects are likely to be caused by the encroachment of infrastructures into the aquatic environment. The direct environmental effects of their construction on the environment will be temporary (a few weeks to a few months).

Circulation of big ships in Deception Bay

As of 2013, about twenty ships will visit Deception Bay each year: 11 for the NNiP and nine for the Raglan project. The ships are needed to export the ore concentrate and replenish equipment and petroleum products.

Circulation of small ships in Deception Bay

The exact number of small ships (fishing vessels and scientific survey boats, launches, zodiacs) travelling in the bay is unknown but small. Aside from a few occasional needs (such as scientific surveys and environmental monitoring), the NNiP will not substantially increase the number of small boats in Deception Bay.

Climate change

Nunavik is already feeling the impacts of climate change (see section 6.1.3.4). Greater warming of the water in Deception Bay and a change to the ice regime and pack ice dynamic are likely or already observed consequences of the higher air temperatures. Climate change is also expected to modify the feeding and reproductive habitats and migratory behaviour of marine mammals and fish (GENIVAR, 2007b).

8.6.3 Analysis of cumulative effects

8.6.3.1 Marine mammals

The analysis of the cumulative effects of navigation on marine mammals is adapted from the study in the 2007 sector report on navigation prepared for the NNiP (GENIVAR, 2007b; Appendix 23), with some additions and adjustments.

Marine mammals are likely to be affected by:

- changes associated with climate warming
- disturbances to the ice cover caused by ship travel
- risks of collision with the ships and the noise the ships generate

Climate change

Climate change could affect marine mammal populations by changing their habitat and access to food resources.

Marine mammals use a huge array of survival strategies and have particular habitat requirements for feeding, wintering, reproduction, avoiding predation and facilitating migration (CEMAM, 2006). Coastal regions and estuarine and soft water habitat used by marine species will probably be affected by large increases in temperature in the years to come (FCIA, 2005). Changes associated with the distribution of pack ice, habitat quality, and the prey-predator dynamic could generate substantial changes in the lifestyle of marine mammals, their migratory periods and routes. At this time, the alteration of reproduction grounds and access to food are certainly the key elements involved in the change to migration schemes.

Scientists note that the reduction in pack ice has been accelerating in the last few years. It has been shown that the reduction lowers the successful reproduction of adult seals, increases infant mortality and leads to changes in the availability of resources for pups (Friedlaender and coll., 2007). Long-term habitat modification could change the distribution of marine mammals, particularly seals that live on the ice. Habitat change could either reduce their populations or force them to extend their range northward.

Marine mammals are, of course, highly adapted to extreme climate fluctuations and some species depend on them (Friedlaender and coll., 2007). Their responses to climate change are often specific and vary from species to species.

Navigation

Although little developed at this point within Deception Bay, marine transport during the ice period could change the habitat of marine mammals by modifying the ice surface or creating temporary channels. The ringed seal's habitat is most at risk of impact (SENES, 2005), as the species is dependent on the available surface of pack ice to calve and raise its young (Johnston, et al, 2005; Lavigne, 2006; Friedlaender et al, 2007).

In Deception Bay, the potential cumulative impact of navigation is associated with the increase in maritime traffic for the resupply process and NNiP export of ore concentrates. The number of trips per year would rise to about twenty (11 trips for the NNiP project, nine for the Raglan project). No further increases are expected during the period covered.

Despite the increase associated with NNiP, the average frequency of trips would be just two boats a month during the open water period. With this little traffic, and no trips at all between March 15 and June 15, there will be long periods free of disturbance for the marine mammals. Moreover, the trip through Deception Bay lasts from 2 to 24 hours, depending on whether or not there is ice.

Given that ships always take the same track (map 7.5), only affecting a very small proportion of Deception Bay pack ice, it is unlikely that the change in ice cover will significantly affect ringed seals' calving and nursing habitat. Moreover, it only takes a few hours for the ice to reform after a ship has passed during the winter. The suspension of marine transport from mid-March to mid-June coincides with the period in which seals are concentrated on pack ice for calving. This critical period of their life cycle can thus unfold without disruption.

Short-term reactions, such as an instant abandonment of reproduction and feeding areas, suggest that repeated noise, such as the noise put out by a boat prop, could have cumulative negative impacts on marine mammals (Richardson et al., 1991). Acoustic interference caused by marine traffic substantially changes socialization and reproduction behaviours (Richardson et al., 1995; Popper et al., 2000). This kind of change to the environment's sound can trigger flight movements and cause mothers to be separated from their offspring. If females with their young must repeatedly abandon nursing, weaning or feeding zones, newborns are vulnerable to exhaustion and predation (McCauley et al., 2000a,b).

In Deception Bay, the Inuit have not noted any change to the behaviour of marine mammals during ship passage, except for a temporary grouping in wakes noted by hunters (Don Cameron, Nuvumiut Developments Inc., pers. comm, 2007). A study also showed that seal air holes are more dense in the frozen wake behind an ice breaker than in the surrounding ice cover (Alliston, 1980 in Mansfield, 1983). However, the impact of increasing passage frequency is undetermined.

In terms of small ship circulation, the NNiP could make it increase very slightly. Moreover, these vessels do not operate during the winter; when they do operate, they do so at low speed, greatly reducing the risks of collision and noise emissions.

The intermittent nature of navigation, exclusion period, use of the same track, and speed limit on large ships (decrease in noise intensity) mean that there will be no significant impact on the conditions conducive to maintaining the marine mammal populations that use Deception Bay. Consequently, the cumulative impact of marine transportation on marine mammals that use Deception Bay caused by NNiP's activities is judged to be slight.

However, the combination of the three types of nuisance (sound, physical and climatic) associated with marine traffic is likely to have a long-term effect on the marine mammals that use Deception Bay. Navigation activities should be monitored to judge whether they are putting additional pressure on the ecology, despite the mitigation measures in place. A navigation monitoring program was set up for this purpose subsequent to authorization from the NNiP in 2008 (Appendix 24).

8.6.3.2 Inuit use of the land for traditional purposes

Climate change

Climate change is having a clear impact on Nunavik. It is seeing substantial average temperature increases, later snow cover and ice formation, earlier thaw, more frequent winter mild spells, the precipitation regime is changing, and the frequency and intensity of geomorphological processes is increasing in response to these changes (section 6.1.3.4).

These changes have direct impacts on the flow of traditional Inuit activities, particularly by affecting access to hunting and fishing grounds and by changing the habitats of the animals they count on. For example, in the spring of 2012, Salluit hunters did not harvest a single seal as a result of very early ice breakup (N. Tayara, Qaqqalik Landholding Corporation, pers. comm., 2012).

Navigation

Deception Bay is considered an essential subsistence area for the Salluit Inuit (ARK, 1998). It is the site of fishing, hunting of marine mammals and waterfowl, and shellfish harvesting. During the winter, the Inuit develop a network of snowmobile trails for accessing their hunting grounds (map 6.6).

The potential cumulative effects of constructing CRI's port infrastructures and the increase in marine traffic on traditional use of the territory are primarily more frequent fracturing of the ice cover during ship travel, increased disturbance to seal habitat and the loss of a potential shellfish harvesting area (blue mussel and Icelandic scallop).

Previously, it was determined that the cumulative impact of increased marine traffic on ice cover in Deception Bay and seal habitat was minor. A set of mitigation measures will also be applied to minimize the direct impacts of ship traffic on use of the territory (ice breaker passage warning protocol, maintenance of a second ice bridge, etc.). For these reasons, the cumulative impacts on traditional Inuit use of the territory are deemed to be minor.

Lastly, the construction of the CRI port infrastructures will cause the loss of a potential shellfish harvesting zone. The loss is in addition to the loss that occurred when the Xstrata wharf was built, and the small jetty on Plage du Bombardier. Given the small surface area (about 9,350 m²) of the cells and ballasts protecting the proposed infrastructures and the very broad availability of other potential harvesting zones in Deception Bay, the cumulative impact is deemed to be minor.

In short, the port infrastructure project is unlikely to have major cumulative impacts on traditional Inuit use of the territory.

8.6.3.3 Fish habitat

Climate change

As yet, we know little about the impacts climate change could have on the biology of Arctic fish or their habitat. First, the effects are more difficult to predict for marine and estuarine habitats, as they are more complex than fresh water habitats.

For the Arctic char (anadromous species), the primary species the Inuit fish, temperature increases, changes to seasonal cycles and precipitation regimes, and changes to ocean currents could affect the availability of its food, which it obtains in the sea, facilitate or hamper migration due to heavier or lighter currents, and change the spawning and hatching periods. Habitat transformation could also create competition with other species, which could increase their ranges due to favourable conditions (e.g., an increase in water temperature) (AADNC, 2012).

Port infrastructures

The construction of port infrastructures in Deception Bay will modify fish habitat without causing a net loss, given the new habitat created by the ballasts protecting the sheet piling cells. No cumulative impact is expected.

9. ENVIRONMENTAL MONITORING AND FOLLOW-UP PROGRAMS

9.1 Environmental Monitoring

The environmental monitoring program includes activities designed to monitor activities that generate environmental impacts and to verify if the planned mitigation measures have been implemented and effective. These measures may have been voluntarily proposed by CRI or imposed by the federal or provincial regulatory authorities when issuing authorizations or permits for the project. More specifically, the monitoring includes the following: 1) General site monitoring; 2) Monitoring of dredging and verification of morphology (bathymetry) of the seabed dredging sites, before and after work; 3) Verification of the presence of marine mammals during dredging and the construction of the wharf.

In order to ensure that all mitigation measures proposed in the present report are respected, CRI will incorporate specific provisions in the call for tender. CRI will ensure that all mitigation measures in the present ESIA are included in the plans and specifications. These provisions will be integrated in the contracts that will be awarded to contractors.

9.1.1 Site Supervision

During the execution of the work, the Site Supervisor shall ensure that all environmental measures are respected. The Supervisor shall also ensure the effectiveness of these measures and, if required, inform the authorities and propose alternative protective measures. An environmental monitoring form is presented in Appendix 23. This form will allow the Site Supervisor to monitor the implementation of mitigation measures. Completed forms must be sent to the regional, provincial and federal authorities upon completion of the work.

9.1.2 Monitoring of Dredging Activities

In addition to general monitoring, specific monitoring of the dredging activities will be carried out. The Supervisor will verify the implementation of the mitigation measures described below.

Management of Work

- Limit the dredged area to a minimum.
- Ensure that a real-time locating system for the clamshell is used to avoid overdredging.

- Ensure that the bathymetry of the dredged area after dredging is conducted to verify that the slopes respect the design plans and specifications.
- Stop dredging during poor weather conditions (e.g. lightning storms, strong winds).

Operational Behaviour

- Handle the sediments carefully so they remain as cohesive as possible.
- Lift and lower the clamshell slowly and in a controlled manner.
- Ensure the dredge operator is aware of the importance of manoeuvres, specifically to avoid sudden movements or when levelling the bottom using the grab sampler or the bucket.
- Control the tightness of the clamshell bucket during operations.
- Control the tightness of the barge compartments during operations.
- Do not overload or operate the barge during poor weather conditions.
- Limit the speed and movements of the dredge and the barge in shallow waters.
- Do not overload the bank and the area within proximity to the shore to reduce the risk of landslides or sediment stripping.

Marine Mammals

- Ensure that qualified marine mammal observers are onshore during dredging.
- Monitor cetaceans at least 30 minutes prior to commencing work.
- Stop dredging if belugas or other marine mammals are present within 400 m of the dredge.

A monitoring report shall be prepared upon completion of the work and sent to the competent authorities.

9.1.3 Monitoring of Marine Mammals during Ramming

The following protection and monitoring measures will be implemented to mitigate the effects of pile ramming and sheet piling on marine mammals.

- Pile ramming and sheet piling will be carried out after July 15, the period of time where belugas carry out the least amount of essential biological activities;
- Cetacean monitoring will be carried out at least 30 minutes prior to pile ramming;

- Ramming activities will begin on a gradual and continuous basis, for 20 to 30 minutes, to allow cetaceans to move away from the noise source;
- A passive monitoring program for the presence of marine mammals will be used to listen to their sounds using hydrophones and their electronic detection using sonars will be implemented;
- An initially intensive visual monitoring program will be implemented to distinguish between passive observations (acoustic) and active observations (visual), which will facilitate the identification of passively observed organisms. Subsequently, the visual monitoring equipment shall only be used to validate the “ambiguous” passive observations;
- An acoustic monitoring program for noise emitted by site activities will be implemented in order to define, in real-time, the safe perimeter (threshold of 160 dB re 1 $\mu\text{Pa}_{\text{rms}}$), to modulate the site equipment and limit the emission of potentially disturbing noise, as well as to assess the need for additional mitigation measures.

A monitoring report will be prepared upon completion of the work and sent the competent authorities.

9.2 Environmental Follow-up Program

The objectives of the environmental follow-up programs are to follow the evolution of certain sensitive environmental components and to verify, over a specific period of time, the accuracy of the predicted significance of the project impacts on these components. The follow-up programs also determine if the impacts were accurately identified and assess the effectiveness of the implemented mitigation measures. They generally include a series of studies and field surveys to observe the changes to the components induced by the project or measure certain parameters. The proposed follow-up programs are described below.

9.2.1 Dredging

The effectiveness of the mitigation measures, aimed to limit the resuspension of sediments and their dispersion, will be largely related to the weather conditions that will prevail during dredging. Considering it is impossible to predict the weather and, consequently, the behaviour of the dispersion plume, 2 follow-up programs are proposed. The objectives of each program are presented below. Details and program methodologies will be defined at a later date and submitted to the competent authorities for approval.

9.2.1.1 Follow-up of Suspended Solids Concentrations

CRI will carry out the follow-up of suspended solid (SS) concentrations at the dredging site (Q1) and at Deception Bay which will enable:

To monitor the evolution of SS concentrations over time;

To monitor the turbidity plume;

To determine, in terms of SS measurements, which areas of Deception Bay were most affected by the increase in SS concentrations;

To delineate the benthic habitats most susceptible to sedimentation.

9.2.1.2 Follow-up of Benthic Habitats

CRI will monitor benthic habitats at Site Q1, which will be located in the immediate vicinity of dredging, where the increase in SS concentrations will be at their peak and where sedimentation is presumed to be significant. The monitoring will cover other benthic habitats susceptible to sedimentation, if required. As mentioned above, the habitats will be located through SS concentration monitoring at Deception Bay during dredging work.

Follow-up of benthic habitats will enable:

- To assess the importance of sedimentation on benthic communities and aquatic grass beds;
- To estimate the time required for habitats to be restored;
- To determine if the benthic communities and the aquatic grass that recolonize the disturbed sites have characteristics similar to those preceding them.

9.2.2 Reconstitution of Habitats on Ripraps

A follow-up program will be implemented to verify the recovery of aquatic habitats on the sheet piles riprap protections. More specifically, this program will follow the evolution of the colonization of the aquatic vegetation and the epibenthos using quantitative indicators (numbers of species, coverage percentage, diversity, etc.). The follow-up will also verify how often fish frequent the ripraps.

This follow-up will be carried out over a 7-year period and will begin 1 year after the construction of marine infrastructures. Measurements and field surveys will be carried out in the month of August in years 1, 3, 5 and 7 following the construction of port infrastructures. A report will be completed for each year monitored. A detailed follow-up protocol will be submitted to the competent authorities for approval.

9.2.3 Sediment Disposal Site

A follow-up program of surface water is proposed to ensure that resurgent water from the sediment disposal site respects the surface water quality criteria and the proposed measures to control the suspended solids are effective.

Surface water monitoring is recommended as follows:

- **During landfill construction and sediment disposal**, if water is present, a surface water sample should be collected weekly from the sampling locations shown on Plan 101-53046-02_F01 to analyze for suspended solids, petroleum hydrocarbons C₁₀–C₅₀ as well as electrical conductivity.
- **During sedimentation**, this frequency can be reduced to one sample per month for each sampling point in the event that none of the samples exceeded the limit values presented in Table 9.1 for two consecutive weeks. This reduction will remain in effect as long as the monthly measurements shows that the limit values are respected; should the limit values be exceeded, the frequency of measurements should be increased to once a week until the situation is rectified for two consecutive weeks.

Table 9.1 Limit Values

Parameters	Acceptable Average Monthly Concentration	Acceptable Maximum Concentration
Petroleum Hydrocarbons C ₁₀ -C ₅₀	----	2 mg/l
Suspended Solids (SS)	15 mg/l	30 mg/l
Electrical Conductivity	----	----

The sedimentation period is defined as the period in which the salt water in the dredged sediments is released. The electrical conductivity is an indicator parameter used to identify this period. The maximum SS concentration was set at 30 mg/l, a maximum increase of 25 mg/L compared to the natural SS concentration of the water at Deception Bay which was measured at 5 mg/l (*MDDEFP*, 2012).

This follow-up program may be stopped should the analytical results show no exceedances of the limit values in Table 9.1 for the parameters analyzed for at least two consecutive years subsequent to the sedimentation period.

Analyses shall be carried out by an MDDEP certified laboratory, in accordance with Section 18.6 of the EQA. All water samples shall be collected in accordance with the guidelines of the most recent version of the *Guide d'échantillonnage* for environmental analyses published by the *MDDEP*.

CRI shall ensure that the results and measurements obtained be recorded in a report describing the sampling methodology (points, locations, instruments, and laboratory) and a confirmation certifying that the samples were collected in accordance with the applicable regulations.

The results obtained and measurements carried out as a part of this follow-up program and environmental monitoring will be included in the annual report submitted to the Regional Director of the *MDDEP*.

9.2.4 Navigation in Deception Bay

In accordance with Condition 3.4 included in the Certificate of Authorization issued in 2008 by the *MDDEP* for the NNI Project and upon the Federal Administrator's decision, also issued in 2008, CRI implemented a follow-up program for the marine navigation in Deception Bay. The protocol is presented in Appendix 24.

10. RÉFÉRENCES

- ACIA, 2005. *Arctic Climate Impact Assessment*. Cambridge : Cambridge University Press, 1042 p. <http://www.acia.uaf.edu>, Chapter 8, 9, 18.
- ADMINISTRATION RÉGIONALE KATIVIK (ARK). 1998. *Plan directeur d'aménagement des terres de la région Kativik. Les grandes orientations d'aménagement et les affectations du territoire. Service de l'environnement et de l'aménagement du territoire*. 67 p. En ligne : <http://geoportal.krg.ca/public/dasCommunity.jsp>
Consulté le 21 septembre 2012.
- ADMINISTRATION RÉGIONALE KATIVIK, 2012. *Administration régionale Kativik, renseignements généraux*. En ligne : <http://www.krg.ca/fr/renseignements-generaux-krq> Consulté le 18 septembre 2012.
- ADMINISTRATION RÉGIONALE KATIVIK, 2010. *Rapport Annuel*. Kuujuaq, 170 p.
- ADMINISTRATION RÉGIONALE KATIVIK, 2009. *Entente – Asphaltage au Nunavik 2010-2014*. Rapport produit par l'ARK, 12 p.
- ADMINISTRATION RÉGIONALE KATIVIK, 2008. *Les changements climatiques au Nunavik et au Nord du Québec : L'accès au territoire et aux ressources*. Rapport final présenté aux Initiatives des écosystèmes nordiques, Environnement Canada. Soumis par : Martin Tremblay et Christopher Furgal, Université Trent. Kuujuaq, 31 mars 2008, 99 p. et annexes.
- ADMINISTRATION RÉGIONALE KATIVIK, 1998. *Plan directeur d'aménagement des terres de la région Kativik. Les grandes orientations d'aménagement et les affectations du territoire*. Service de l'environnement et de l'aménagement du territoire. Kuujuaq : Administration régionale Kativik, 67 p.
- ADMINISTRATION RÉGIONALE KATIVIK ET SOCIÉTÉ MAKIVIK, 2011. *Plan Nunavik*. Kuujuaq : Institut Culturel Avataq, 141 p. En ligne : http://www.makivik.org/wp-content/uploads/2012/06/Plan-Nunavik-06_20.pdf. Consulté le 10 octobre 2012.
- AFFAIRES AUTOCHTONES ET DÉVELOPPEMENT DU NORD CANADA, 2012. *L'outil de gestion de l'environnement et des ressources pétrolières (OGERP). Informations contextuelles sur les composantes valorisées de l'OGERP - l'Arctique de l'Est*. Site internet : <http://www.aadnc-aandc.gc.ca/fra/1315676277753/1315676351336#cli>. Consulté le 13 novembre 2012.

- AFFAIRES AUTOCHTONES ET DÉVELOPPEMENT DU NORD CANADA. 2010. *Convention de la Baie James et du Nord Québécois et La Convention du Nord-Est québécois*. Rapport annuel 1998-1999. Rapport annuel 1999-2000. En ligne http://www.aadnc-aandc.gc.ca/DAM/DAM-INTER-HQ/STAGING/texte-text/cin00_1100100030849_fra.pdf. Consulté le 21 septembre 2012.
- AIR INUIT, 2012. *À propos d'Air Inuit*. En ligne <http://www.airinuit.com/fr/History.aspx> Consulté le 24 septembre 2012.
- ALLARD, M., CALMELS, F., FORTIER, D., LAURENT, C., L'HÉRAULT, E. ET VINET, F. 2007. *Cartographie des conditions de pergélisol dans les communautés du Nunavik en vue de l'adaptation au réchauffement climatique*. Centre Ouranos. 42 p.
- ALLARD, M., FORTIER, R., GAGNON, R. ET MICHAUD, Y., 2004. *Salluit : Une communauté en croissance sur un terrain sensible au changement climatique*. Québec : Université Laval et Commission géologique, 101 p.
- ALLARD, M., FORTIER, R., GAGNON, O. AND MICHAUD, Y. 2004. *Problématique du développement du village de Salluit, Nunavik. Salluit: Une communauté en croissance sur un terrain sensible au changement climatique*. Université Laval, Québec 84 pages.
- ALLARD, M., LEMAY, C. LARRIVÉE, M. TREMBLAY, T. ANNANACK, J. LAMPE. 2007. Initiating the Eastern Subarctic IRIS Approach. Internet. <http://www.arcticnet.ulaval.ca/pdf/talks2007/Allard.pdf>.
- ANCTIL, M. 2008. *Les faits saillants de l'enquête. Enquête de santé auprès des Inuits du Nunavik 2004, Qanuippitaa? Comment allons-nous?* Québec : Institut national de santé publique du Québec (INSP) et Régie régionale de la santé et des services sociaux du Nunavik (RRSSSN).
- ASSOCIATION DES CORPORATIONS FONCIÈRES DU NUNAVIK, 2006. *Page principale du site*. En ligne <http://www.nlhca.com/> Consulté le 18 septembre 2012
- ARTEFACTUEL, 2012. *EIES pour l'aménagement d'infrastructures portuaires et la gestion des sédiments à la baie Déception*. Volet archéologique. 33 p.
- ARTEFACTUEL, 2012. *Projet Nunavik Nickel. Fouille et évaluation du site Ka-Fi-1 (baie Déception, Nunavik)*. 56 p.

- BEAULIEU, N., ALLARD, M. 2003. *The impact of climate change on an emerging coastline affected by discontinuous permafrost: Manitounuk Strait, northern Quebec*. Canadian Journal of Earth Sciences. 40:1393-1404.
- BENOIT, C. 2004. *L'entente Raglan: outil efficace pour favoriser la formation et l'emploi inuit? Évaluation et documentation de la situation de l'emploi des Inuits à la mine Raglan, au Nunavik, dans le cadre de l'entente sur les impacts et bénéfices*. Montréal : Université du Québec à Montréal, 171 p.
- BLONDEAU, M. 2004. Atlas des plantes des villages du Nunavik. *En collaboration avec C. Roy, A. Cuerrier et l'Institut culturel Avataq*. Éditions MultiMondes, Sainte-Foy, Québec. 610 p.
- BOURDAGES, H., LESAGE, V., HAMMILL, M.O., DE MARCH, B. 2002. *Impact of harvesting on population trends of beluga in eastern Hudson Bay*. Research document 2002/036. Canadian Science Advisory Secretariat. Fisheries and Oceans Canada. 46 p. En ligne <http://www.dfo-mpo.gc.ca/csas/>. Consulté le 6 septembre 2006.
- BIOREX Inc., 1999. *Caractérisation biophysique et des usages d'un secteur retenu pour la détermination d'une zone de protection marine dans l'estuaire du Saint-Laurent, volume 2. Les mammifères marins et leurs principales ressources alimentaires*.
- BOWEN, W. D., 2006. Ministère des Pêches et des Océans Institut océanographique de Bedford.
- BRAY, R.N., A.D. BATES et J.M. LAND. 1997. *Dredging – A handbook for engineers*. 2e édition. Butterworth-Heinemann, Boston. 434 p.
- BRAY, R.N. – Editor. 2008. *Environmental Aspects of Dredging*. Taylor & Francis Group. 386 p.
- CANADIAN ROYALTIES, 2012. *À propos de Canadian Royalties*. En ligne <http://www.canadianroyalties.com/fr/> Consulté le 24 septembre 2012 :
- CEMAM, 2006. *Recherche sur les mammifères marins, Un aperçu*. Rapport Pêches et Océans Canada. 78 p.
- COMMISSION DE L'ENVIRONNEMENT KATIVIK, 2008. *Décision relative au projet nickélifère Nunavik Nickel par Canadian Royalties Inc*. 40 pages. En ligne <http://www.mddep.gouv.qc.ca/evaluations/projet/maj/Decision-CQEK.pdf> Consulté le 5 octobre 2012.

- COMMISSION SCOLAIRE KATIVIK, 2012. *À propos de la CSK*. Consulté le 18/09/2012 : <http://www.kativik.qc.ca/fr/a-propos-de-la-csk>
- COMMISSION DE L'ENVIRONNEMENT KATIVIK, 2008. *Décision relative au projet nickélicifère Nunavik Nickel par Canadian Royalties Inc.* 40 pages. En ligne <http://www.mddep.gouv.qc.ca/evaluations/projet/maj/Decision-CQEK.pdf> Consulté le 5 octobre 2012.
- CONFÉRENCE DES MINISTRES DE L'ÉNERGIE ET DES MINES, 2005. *Rapport d'activités 2004-2005 pour le Nunavik*, Fonds d'exploration minière du Nunavik, 7 p.
- CONSEIL DU STATUT DE LA FEMME, 2005. *Les conditions de vie des femmes dans le Nord-du-Québec, 2004*. Collection Femmes et développement des régions, 51 p.
- CONSEIL RÉGIONAL DE DÉVELOPPEMENT KATIVIK, 1998. *Stratégie de développement pour la région Kativik*, Kuujuaq, septembre 1998, 33 p.
- COSEPAC, 2012. Comité sur les espèces en péril au Canada En ligne http://www.cosewic.gc.ca/fra/sct0/rpt/rpt_csar_f.pdf. Consulté le 11 octobre 2012.
- COSEPAC. 2011. Espèces sauvages canadiennes en péril. Comité sur la situation des espèces en péril au Canada. 104 p.
- COSEPAC. 2006. Espèces canadiennes en péril. Comité sur la situation des espèces en péril au Canada. 82 p.
- COSEPAC, 2005. *Évaluation et Rapport de situation du COSEPAC sur la baleine boréale (Balaena mysticetus) au Canada – Mise à jour*. Comité sur la situation des espèces en péril au Canada. Ottawa. viii + 57 p. (www.registrelep.gc.ca/status/status_f.cfm).
- COSEPAC, 2004a. *Évaluation et Rapport de situation du COSEPAC sur le béluga (Delphinapterus leucas) au Canada – Mise à jour*. Comité sur la situation des espèces en péril au Canada. Ottawa. x + 77 p.
- COSEPAC, 2002. http://www.cosewic.gc.ca/fra/sct1/searchdetail_f.cfm.
- CSIRO Marine and Atmospheric Research. 2012. *Sea level rise: understanding the past - Improving projections for the future*. IPCC AR4 sea-level projections - an update. http://www.cmar.csiro.au/sealevel/sl_proj_21st.html. Consulté le 2 octobre 2012.

- DAIGNEAULT, R.-A. 1997. *Géologie et géomorphologie de la région du cratère du Nouveau-Québec, Nunavik*. Rapport préparé pour le ministère de l'Environnement et de la Faune, Direction des parcs québécois. 117 p. + annexes.
- DESSAU INC. 2010. Programme de surveillance et de suivi environnemental des travaux de dragage au quai de Rivière-du-Loup, 2009. Rapport final remis à la Société des traversiers du Québec. 46 p. et annexes
- DIRECTEUR GÉNÉRAL DES ÉLECTIONS DU QUÉBEC, 2011. *Référendum sur la création du gouvernement régional du Nunavik*, article paru en ligne le 28 avril 2011. Consulté en ligne le 18/09/2012 : <http://www.electionsquebec.qc.ca/francais/actualite-detail.php?id=3930>
- DUHAIME, G. et V. ROBICHAUD, 2010. « L'économie du Nunavik entre 1983 et 2003 », *Recherches sociographiques*, vol. 51, no 1-2, 2010, p. 45-73.
- DUHAIME, G., 2009. *La pauvreté au Nunavik : État des connaissances*. Québec : Université Laval et Chaire de recherche du Canada en condition autochtone comparée, 46 p.
- DUHAIME, G., 2008. Profil socioéconomique du Nunavik. Québec : Université Laval et Chaire condition autochtone, 71 p.
- DUHAIME, G. et V. ROBICHAUD, 2007. *Portrait économique du Nunavik*. Université Laval. Chaire de recherche du Canada sur la condition autochtone comparée.
- DUHAIME, G., 2004. La situation économique du Nunavik et l'avenir de l'État, Québec, Chaire de recherche du Canada sur la condition autochtone comparée, Centre interuniversitaire d'études et de recherches autochtones, Université Laval, collection Recherche en ligne, 9 p.
- DUTIL, D., 2010. *La situation du logement et des ménages dans la région administrative du Nord-du-Québec*, Bulletin d'information de la société d'habitation du Québec, vol. 4, no. 3, 12 p.
- EMPLOYMENT, TRAINING, INCOME SUPPORT AND CHILD CARE DEPARTMENT, 2006. *Jobs in Nunavik in 2005*. Kativik Regional Government, 62 p.
- ENVIRONNEMENT Canada, 2004. En ligne http://www.dfo-mpo.gc.ca/species-speces/species/species_bowheadwhale_eastartic_f.asp

- ENVIRONNEMENT CANADA. 2002a. *Guide d'échantillonnage des sédiments du Saint-Laurent pour les projets de dragage et de génie maritime. Volume 1 : Directives de planification. Environnement Canada, Direction de la Protection de l'environnement, Région du Québec, Section innovation technologique et secteurs industriels.* Rapport. 106 p.
- ENVIRONNEMENT CANADA. 2002 b. *Guide d'échantillonnage des sédiments du Saint-Laurent pour les projets de dragage et de génie maritime. Volume 2 : Manuel du praticien.* Environnement Canada, Direction de la Protection de l'environnement, Région du Québec, Section innovation technologique et secteurs industriels. Rapport. 107 p.
- ENVIRONNEMENT CANADA ET MINISTÈRE DU DÉVELOPPEMENT DURABLE, DE L'ENVIRONNEMENT ET DES PARCS DU QUÉBEC (MDDEP). 2007. *Critères pour l'évaluation de la qualité des sédiments au Québec et cadres d'application : prévention, dragage et restauration.* 39 p.
- ENVIRONNEMENT CANADA. 2012. Service canadien des glaces. Internet. <http://www.ec.gc.ca/glaces-ice/default.asp?lang=Fr&n=D32C361E-1>.
- ENVIRONNEMENT CANADA. 1994. *Répercussions environnementales du dragage et de la mise en dépôt des sédiments.* Document préparé par Les Consultants Jacques Bérubé inc. pour la Section du développement technologique. Direction de la protection de l'environnement, régions du Québec et de l'Ontario. 109 p.
- FAPAQ. 2000. Parc des Pingualuit, *État des connaissances.* Direction de la planification et du développement des parcs québécois. 133 p.
- FESTA-BIANCHET, M., RAY, J.C., BOUTIN, S. et A.GUNN, 2011. *Conservation of caribou (Rangifer tarandus) in Canada: an Uncertain Future.* P. 419-433. Canadian Journal of Zoology En ligne www.nrcresearchpress.com/cjz Consulté le 10 octobre 2012.
- FRIEDLAENDER, A.S., JOHNSTON, D.W., FINK, S.L., LAVIGNE, D.M. 2007. *Variation in ice Cover on the East Coast of Canada, February-march, 1969-2006: implications for harp and hooded seals.* IFAW Technical Report 2007-1.
- GENIVAR, 2012a. *Étude d'impact environnementale et sociale pour l'aménagement d'infrastructures portuaires et la gestion des sédiments à la baie Déception. Modélisation hydrodynamique de la baie Déception.* Rapport de GENIVAR à Canadian Royalties Inc. 32 p. et annexes.

- GENIVAR, 2012b. *Étude d'impact sur l'environnement et le milieu social pour l'aménagement d'infrastructures portuaires et la gestion des sédiments à la baie Déception. Caractérisation de l'environnement sonore sous-marin - 2012. Rapport de GENIVAR à Canadian Royalties Inc. 47 p. et annexes.*
- GENIVAR, 2012c. *Étude d'impact environnementale et sociale pour l'aménagement d'infrastructures portuaires et la gestion des sédiments à la baie Déception. Inventaire des espèces vasculaires menacées ou vulnérables. Rapport sectoriel. Rapport de GENIVAR à Canadian Royalties Inc. 32 p. et annexes.*
- GENIVAR, 2012d. *Étude d'impact environnementale et sociale pour l'aménagement d'infrastructures portuaires et la gestion des sédiments à la baie Déception. Rapport sectoriel sur la faune aviaire. Rapport de GENIVAR à Canadian Royalties Inc. 32 p. et annexes.*
- GENIVAR, 2012e. *Étude d'impact environnementale et sociale pour l'aménagement d'infrastructures portuaires et la gestion des sédiments à la baie Déception. Étude d'intégration au milieu visuel. Rapport sectoriel. Rapport de GENIVAR à Canadian Royalties Inc. 32 p. et annexes.*
- GENIVAR, 2012f. *Étude d'impact environnementale et sociale pour l'aménagement d'infrastructures portuaires et la gestion des sédiments à la baie Déception. Inventaire des espèces vasculaires menacées ou vulnérables. Rapport sectoriel. Rapport de GENIVAR à Canadian Royalties Inc. 19 p. et annexes.*
- GENIVAR, 2011. *Construction d'infrastructures portuaires pour les activités du projet Nunavik Nickel – Rapport principal – Étude d'impact sur l'environnement et le milieu social. Rapport de GENIVAR Société en commandite pour Canadian Royalties inc., 158 p. et annexes*
- GENIVAR, 2008a. *Étude d'impact sur l'environnement et le milieu social - Rapport sectoriel final - Inventaires 2006 et 2007 dans la baie Déception. Rapport préparé pour Canadian Royalties Inc. 60 p. et annexes.*
- GENIVAR, 2008b. *Projet Nunavik Nickel. Étude d'impact sur l'environnement et le milieu social. Réponses aux questions – 2^e série. Présenté à l'Agence canadienne d'évaluation environnementale. Questions et commentaires de Pêches et Océans Canada, Transports Canada et Environnement Canada. 34 p.*
- GENIVAR, 2007a. *Projet nickélicifère Raglan Sud – Rapport principal – Étude d'impact sur l'environnement et le milieu social. Rapport de GENIVAR Société en commandite pour Canadian Royalties inc., 649 p. et annexes.*

- GENIVAR, 2007b. *Projet Nunavik Nickel – Étude sur la navigation maritime dans la baie Déception - Impacts sur les mammifères marins et les activités traditionnelles Inuites. Rapport final – Révision no 1 - Rapport sectoriel – Étude d'impact sur l'environnement et le milieu social.* Rapport de GENIVAR pour Canadian Royalties inc. 75 p. et annexes.
- GENIVAR, 2007c. *Projet Nickélicifère Raglan Sud – Caractérisation des sols et des roches. Rapport sectoriel final – Étude d'impact sur l'environnement et le milieu social.* Rapport de GENIVAR pour Canadian Royalties inc. 106 p. et annexes.
- GERARDIN, V. ET MCKENNEY, D. 2001. *Une classification climatique du Québec à partir de modèles de distribution spatiale de données climatiques mensuelles: vers une définition des bioclimats du Québec.* Dans Contribution du Service de la cartographie écologique, Québec, p. 39.
- GOLDER. 2007. *Interim kinetic test results on waste rock samples. Raglan South Nickel Project, Nunavik, Québec.* Technical memorandum prepared for Canadian Royalties inc. February 2007.
- GOVERNEMENT DU QUÉBEC. 2012. *Arrêté ministériel concernant la publication d'une liste d'espèces de la flore vasculaire menacées ou vulnérables susceptibles d'être ainsi désignées et concernant la publication d'une liste des espèces de la faune menacées ou vulnérables susceptibles d'être ainsi désignées [c. E-12.01, r. 4]. Annexe 1. Liste des espèces floristiques menacées ou vulnérables susceptibles d'être ainsi désignées.* Les Publications du Québec, Éditeur officiel du Québec, 1^{er} juillet 2012, 11 p.
- GOVERNEMENT DU QUÉBEC, 2012a. *Loi sur le régime des terres dans les territoires de la Baie-James et du Nouveau-Québec.* En ligne http://www2.publicationsduquebec.gouv.qc.ca/dynamicSearch/telecharge.php?type=2&file=/R_13_1/R13_1.html. Consulté le 18 septembre 2012.
- GOVERNEMENT DU QUÉBEC, 2012b. *Loi sur les villages nordiques et l'administration régionale Kativik. L.Q.R., chapitre V-6.1.* En ligne http://www2.publicationsduquebec.gouv.qc.ca/dynamicSearch/telecharge.php?type=2&file=/V_6_1/V6_1.html. Consulté le 18 septembre 2012.
- GOVERNEMENT DU QUÉBEC, 2011. *Faire le Nord ensemble : le chantier d'une génération.* Québec : Ministère des Ressources naturelles et de la Faune, 156 p. En ligne <http://plannord.gouv.qc.ca/documents/plan-action.pdf> Consulté le 10 octobre 2012.

- GOUVERNEMENT DU QUÉBEC, 2008. Le Nunavik ou la terre où vivre. *Développement social*, juin 2008, vol. 9, no. 1, 72 p.
- GOUVERNEMENT DU QUÉBEC, 2008. Le Nunavik ou la terre où vivre. *Développement social*, juin 2008, vol. 9, no. 1, 72 p.
- GRAY, J.T., DE BOUTRAY, B., HILLAIRE-MARCEL, C., AND LAURIOL, B. 1980. *Postglacial emergence of the west coast of Ungava Bay, Quebec*. *Arctic and Alpine Research*, 12: 19-30.
- GRAY, J. B. LAURIOL, D. BRUNEAU, J. RICARD. 1993. *Postglacial emergence of Ungava Peninsula, and its relationship to glacial history*. *Can. J. Earth Sci.* 30, 1676-1696.
- GRAY, J.S. et M. ELLIOTT. 2009. *Ecology of marine sediments : from science to management*. 2e édition. Oxford University Press, New York. 225 p.
- GRAY ET SEPPALA. 1991. *Deeply Dissected Tundra Polygons on a Glacio-Fluvial Outwash Plain, Northern Ungava Peninsula, Québec*. *Géographie physique et Quaternaire*. 45 :111-117
- HAMMILL, M.O., LESAGE, V. 2005. *Évaluation du stock de beluga du Nord-du-Québec (Nunavik) (Delphinapterus leucas)*. Pêches et Océans Canada, région du Québec. 12 p.
- HAMMILL, M.O., STENSON, G., 2005. *Abundance of Northwest Atlantic harp seals (1960-2005)*. Fisheries and Oceans Canada. Canadian Science Advisory Secretariat. Document 2005/090. 15 p. + tableaux + figures.
- HEGMANN, G., COCKLIN, C., CREASEY, R., DUPUIS, S., KENNEDY, A., KINGSLEY, L., ROSS, W., SPALING, H., STALKER, D. 1999. *Évaluation des effets cumulatifs, Guide du praticien*. Rédigé par AXYS Environmental Consulting Ltd. et le groupe de travail sur l'évaluation des effets cumulatifs à l'intention de l'Agence canadienne d'évaluation environnementale, Hull, Québec.
- HERBICH, J.B. 1992. *Handbook of dredging engineering*. McGraw-Hill Inc., Montréal. Pagination multiple.
- ILLINWORTH & RODKIN INC. 2007. *Compendium of pile driving sound data*. Préparé pour California Department of Transportation. Sacramento, Californie. 129 p.

- INSTITUT NATIONAL DE SANTÉ PUBLIQUE DU QUÉBEC, 2006. *Portrait de santé du Québec et de ses régions 2006 : les statistiques – Deuxième rapport sur l'état de santé de la population du Québec*. Québec : Gouvernement du Québec, 659 p.
- IPCC, 2007. *Climate change 2007 : Working Group I : The Physical Science Basis*. http://www.ipcc.ch/publications_and_data/ar4/wg1/en/spmsspmp-projections-of.html. Consulté le 18 septembre 2012.
- JEAN, D., LAMONTAGNE, G. 2004. *Plan de gestion du caribou (Rangifer tarandus) dans la région du Nord-du-Québec 2004-2010*. Ministère des Ressources naturelles et de la Faune – Secteur Faune Québec, Direction de l'Aménagement de la faune du Nord-du-Québec. 86 p. En ligne http://www.mrn.gouv.qc.ca/publications/faune/caribous_plan_gestion_2004_2010.pdf Consulté le 5 octobre 2012.
- JOHNSTON, D.W., FRIEDLAENDER, A.S., TORRES, L.G., LAVIGNE, D.M., 2005. *Variation in sea ice cover on the east coast of Canada from 1969 to 2002 : climate variability and implications for harp and hooded seals*. *Climate Research* 29:209-222.
- KUMAR, P. (éditeur) 2010. *The economics of ecosystems and biodiversity – Ecological and economic foundations*. Earthscan, Washington, DC. 306 p. et annexes.
- L'HERAULT, M. 2009. *Contexte climatique critique favorable au déclenchement de ruptures de mollisol dans la vallée de saluit, nunavik*. Mémoire de maîtrise, Université L'Aval. Québec. 135 pages+annexes.
- LABORATOIRE D'EXPERTISE DU QUÉBEC. 2007. *Étude géotechnique sur les forages réalisés dans la baie Déception*. Rapport no 4264-09-02 du Laboratoire d'Expertise du Québec présenté à GENIVAR.
- LAIST, D. W., KNOWLTON, A. R., MEAD, J. G., COLLET, A. S., PODESTA, M., 2001. *Collisions between ships and whales, Marine Mammal Science*, vol. 17, no 1, pp. 35-75
- LANDRY, B., MERCIER, M. 1992. *Notions de géologie*. Modulo éditeur (3e édition). 565 p.
- LAURIOL, B., A. CHAMPOUX ET J.T. GRAY. *Répartition estivale des surfaces enneigées en Ungava, Nouveau-Québec*. *Géographie physique et Quaternaire*, 38 : 37-47.

- LAVIGNE, D. M., 2006. *Notes for a presentation to the Standing Committee on Fisheries and Oceans, House of Commons, Ottawa*. Tuesday, 12 December 2006. International Fund for Animal Welfare, Guelph, Canada. 12 pp.
- LAVOIE, C., M. ALLARD. 2008. (remplacer par : Lavoie. C. 2006. *Géomorphologie et quaternaire du lac guillaume-delisle, Nunavik, Canada*. Thèse de doctorat, université laval. 123 p.
- HAMMILL, M.O., LESAGE, V. 2005. *Évaluation du stock de beluga du Nord-du-Québec (Nunavik) (Delphinapterus leucas)*. Pêches et Océans Canada, région du Québec. 12 p.
- INSTITUT NATIONAL DE SANTÉ PUBLIQUE DU QUÉBEC, 2006. *Portrait de santé du Québec et de ses régions 2006 : les statistiques – Deuxième rapport sur l'état de santé de la population du Québec*. Québec : Gouvernement du Québec, 659 p.
- JEAN, D., LAMONTAGNE, G. 2004. *Plan de gestion du caribou (Rangifer tarandus) dans la région du Nord-du-Québec 2004-2010*. Ministère des Ressources naturelles et de la Faune – Secteur Faune Québec, Direction de l'Aménagement de la faune du Nord-du-Québec. 86 p. En ligne http://www.mrn.gouv.qc.ca/publications/faune/caribous_plan_gestion_2004_2010.pdf Consulté le 5 octobre 2012.
- LÉVESQUE, R., ALLARD, M., SÉGUIN, M. K., P. J. 1990. *Données préliminaires sur le régime thermique du pergélisol dans quelques localités du Nunavik, Québec*. Proceedings, 5th Canadian Permafrost Conference. C. d. é. Nordiques. Université Laval, Québec. 54: 207-213.
- LINDHOLM, J.B., P.J. AUSTER et L.S. KAUFMAN. 1999. *Habitat-mediated survivorship of juvenile (0-year) Atlantic cod Gadus morhua*. Marine Ecology Progress Series 180 : 247-255.
- MARTIN, T., 2003. *De la banquise au congélateur. Mondialisation et culture au Nunavik*, Sainte-Foy, Les Presses de l'Université Laval, 202 p.
- McCAULEY, R. D., FEWTRELL, J., DUNCAN, A. J. JENNER, C., JENNER, M-N., PENROSE, J.D., PRINCE, R.I.T., ADHITYA, A., MURDOCH, J. MCCABE, K., 2000a. *Marine seismic surveys: analysis and propagation of air-gun signals; and effects of air-gun exposure on humpback whales, sea turtles fishes and squid*. Curtin University of Technology, Project CMST 163, Report R99-15, 198 pages.

McCAULEY, R.D., FEWTRELL, J., DUNCAN, A.J. JENNER, C., JENNER, M-N., PENROSE, J.D., PRINCE, R.I.T., ADHITYA, A., MURDOCH, J., MCCABE, K., 2000b. *Marine seismic surveys-a study of environmental implications*. APPEA Journal, 40, 692-708.

MINISTÈRE DU DÉVELOPPEMENT DURABLE, DE L'ENVIRONNEMENT DE LA FAUNE ET DES PARCS. 2012. *Critères de qualité de l'eau de surface*. En ligne :http://www.mddep.gouv.qc.ca/eau/criteres_eau/index.asp. Consulté le 6 novembre 2012.

MDDEP, 2008. *Certificat d'autorisation pour le projet minier Nunavik Nickel*. N/Réf. : 3215-14-007. 13 p.

MINISTÈRE DU DÉVELOPPEMENT DURABLE ET DES PARCS, 2005. Plan directeur : Parc national des Pingualuit. Québec : MDDEP, 60 p.

MINISTÈRE DU DÉVELOPPEMENT DURABLE ET DES PARCS. 1998. Politique de protection des sols et de réhabilitation des terrains contaminés.

MINISTÈRE DES RESSOURCES NATURELLES DE LA FAUNE (MRNF). 2005. Statistiques de chasse et de piégeage. En ligne : <http://www.fapaq.gouv.qc.ca/fr/faune/statistiques/index.htm> Consulté le 7 septembre 2006.

MINISTÈRE DES RESSOURCES NATURELLES DE LA FAUNE (MRNF). 2012. Statistiques de chasse et de piégeage. En ligne <https://www.mrnf.gouv.qc.ca/faune/statistiques/chasse/caribou-2011-2012.jsp> Consulté le 9 septembre 2012.

MINISTÈRE DES RESSOURCES NATURELLES DU QUÉBEC. 2012. *Liste des espèces désignées menacées ou vulnérables au Québec*. <http://www3.mrnf.gouv.qc.ca/faune/especes/menacees/liste.asp>. Consulté le 22 octobre 2012.

MINISTÈRE DE LA SANTÉ ET DES SERVICES SOCIAUX, 2008. *Portrait des infections transmissibles sexuellement et par le sang (ITSS) au Québec : Année 2007 (et projections 2008)*. Collection analyses et surveillance, 84 p.

MORTON, J.W. 1977. Ecological effect of dredging spoil disposal : a literature review. United States Department of the Interior, Fish and Wildlife Service, Washington D.C. XX p.

MPO, 2007a. *Impacts de la construction d'un port méthanier à Gros-Cacouna sur les mammifères marins*. Secr. can. de consult. sci. du Ministère des Pêches et Océans. Rép. des Sci. 2007/010.

- MPO, 2007b. *Sur la piste des bélugas de l'Arctique canadienne* - Ministère des Pêches et Océans. Commentaire de Pierre Richard.
www.dfo-mpo.gc.ca/science/Stor/central_arctic/whales_f.htm
- NGI et Sierra Neige. 2010. *Avalanche Hazard Assessment*. Deception Bay, Salluit, Nunavik, Quebec, Canada. 27 pages+annexes.
- NUNAVIK'S REGIONAL DEVELOPMENT COUNCIL, 2002. *Orientation and perspectives for actions to fight poverty*. Kuujuaq : Nunavik's Regional Development Council.
- NUNAVIK LANDHOLDING CORPORATIONS ASSOCIATION. 2012. *Droits et pouvoirs sur les terres de catégorie 1*. En ligne :
<http://nlhca.strata360.com/> Consulté le 9 octobre 2012.
- NUNAVIK TOURISM. 2012. En ligne :
http://www.nunavik-tourism.com/page.aspx?page_id=71
 Consulté le 21 septembre 2012.
- NUNIVAAT, 2012. *Nunavik, total population, 1961, 1966, 1971, 1976, 1981, 1986, 1991, 1996, 2001, 2006, 2011*. En ligne :
<http://www.nunivaat.org/TableViewer.aspx?S=2&ID=12961>
 Consulté le 10 octobre 2012.
- OURANOS. 2007. (Celle que tu utilise pour les données de changement climatique)
- PARCS NUNAVIK, 2012. *Au sujet des parcs: historique*. Consulté le 24/09/2012 :
<http://www.nunavikparks.ca/fr/introduction/historique.htm>
- PENNY, C., SENÉCAL, S. ET BOBET, E., 2009. *Mortalité par suicide dans les collectivités inuites au Canada : taux et effets des caractéristiques des collectivités*, Cahiers québécois de démographie, vol. 38, n° 2, p. 311-343.
- PERRIN, W.F., Wursig, B., Thewissen, J.G.M., 2002. *Encyclopedia of Marine Mammals*. Academic Press, 1414pp.
- POPPER, A.N., DEFERRARI, H.A., DOLPHIN, W.F., EDDS-WALTON, P.L., GREVE, G.M., McFADDEN, D., RHINES, P.B., RIDGWAY, S.H., SEYFARTH, R.M., SMITH, S.L., TYACK, P.L., 2000. *Marine mammals and low-frequency noise: progress since 1994*. National Academy Press, Washington, D.C. (<http://www.nap.edu/openbook/030906886X/html>).
- RÉGIE RÉGIONALE DE LA SANTÉ ET DES SERVICES SOCIAUX NUNAVIK, 2012. *Mission*. En ligne :
http://www.rrsss17.gouv.qc.ca/index.php?option=com_content&view=article&id=20&Itemid=103&lang=fr Consulté le 18 septembre 2012.

- RÉGIE RÉGIONALE DE LA SANTÉ ET DES SERVICES SOCIAUX NUNAVIK, 2003. *Les communautés du Nunavik*. Consulté le 20/09/2012 : <http://www.rss17.gouv.qc.ca/fr/nunavik/communautes/default.aspx>
- RESSOURCES NATURELLES CANADA, 2007. *Ententes de partenariat : La mine Raglan – Québec*. Bulletin d'information sur la participation des Autochtones à l'industrie minière, 2 p.
- RÉSÉ-NORD. 2005. *Eaux du Nord : Un guide pour concevoir et mener des observations sur la qualité de l'eau dans le nord du Canada*. 252 p Roche. 2004
- RICE, D.W., 1998. *Marine mammals of the world. Systematics and distribution*. Society for Marine Mammalogy. Spec. Pub. No. 4. 231 p.
- RICHARDSON, W.J., GREENE, C.R.Jr., MALME, C.I., THOMSON, D.H., 1995. *Marine mammals and noise*. Academic Press, San Diego, 576 pages.
- RIEUSSEC, E. 2008. *Analyse comparative des différents modes de gestion des sédiments de dragage en milieux terrestre et marin*. Travail présenté au Centre universitaire de formation en environnement en vue de l'obtention du grade de maître en environnement (M. Env.). Université de Sherbrooke. 122 p.
- ROCHE. 2005. *Expo and Phoenix Project. Preliminary Environmental Baseline Study. Final report to Canadian Royalties Inc., Sainte-Foy, Québec: April 2005*. 51 p. + appendix.
- ROCHE, 1993. *Projet Raglan. Étude d'impact sur l'environnement*. Roche, Québec.
- ROCHE, CANARCTIC, 1993. *Projet Raglan. Évaluation des impacts et des risques associés au transport maritime à Baie Déception*. Présenté à Falconbridge. 100 p et annexes.
- ROCHE, 1992c. *Projet Raglan. Étude sur l'occupation et l'utilisation du territoire par les Inuit dans la région entre la baie Déception et le havre Douglas, Nunavik*. Vol 3, 107p.
- SENES, 2005. *Vérification environnementale des T.N.-O. Rapport sur l'état de l'environnement Environnement marin*. SENES Consultants Limited.
- SKILLETER, G.A. 1994. *Refuges from predation and the persistence of estuarine clam populations*. Marine Ecology Progress Series 109 : 29-42.

- STANTEC. 2011. GEOTECHNICAL REPORT Proposed Wharf – Site 1. Deception Bay, Quebec 15 pages +annexes.
- SCOTT, W.B., SCOTT, M.G. 1988. Atlantic Fishes of Canada. Canadian Bulletin of Fisheries and Aquatic Sciences No 219. Canada. 731 p.
- SECRÉTARIAT AUX AFFAIRES AUTOCHTONES, 2012. *Ententes avec les Inuits*.
En ligne :
[http://www.saa.gouv.qc.ca/relations_autochtones/ententes/inuits/ententes_inuits.htm](http://www.saa.gouv.qc.ca/rerelations_autochtones/ententes/inuits/ententes_inuits.htm) Consulté le 18 septembre 2012.
- SOCIÉTÉ MAKIVIK, 2012a. *La Société*. En ligne :
<http://www.makivik.org/fr/corporate/> Consulté le 18 septembre 2012.
- SOCIÉTÉ MAKIVIK, 2012b. *Gouvernement régional du Nunavik*. En ligne :
<http://www.makivik.org/fr/building-nunavik/nunavik-government/>.
Consulté le 18 septembre 2012.
- SOCIÉTÉ MAKIVIK, 2007. *Coup d'œil sur le Nunavik*. Kuujuaq : Société Makivik.
- SOCIÉTÉ MAKIVIK, ADMINISTRATION RÉGIONAL KATIVIK ET GOUVERNEMENT DU QUÉBEC, 2008. *Entente de partenariat sur le développement économique et communautaire au Nunavik*. En ligne
<http://www.krg.ca/images/stories/docs/Agreements/Sanarrutik%20version-consolidee-2008%20fr.pdf>. Consulté le 18 septembre 2012.
- SOCIÉTÉ MAKIVIK. 2011. Nunavik Guidebook Mineral Exploration, Mining Development and Nunavik Region: Société Makivik. 31 pages. En ligne
http://www.google.ca/url?sa=t&rct=j&q=&esrc=s&source=web&cd=2&ved=0CCYQFjAB&url=http%3A%2F%2Fnlhca.strata360.com%2Fapp%2Fdmsfiles%2Fdms_download.php%3Fapplication%3Dnlhca%26fileid%3D95&ei=O8V2UKXhHY6k8ATc64DAAQ&usg=AFQjCNFxBsKckQ9Ky_IPNHIOucmayCEw. Consulté le 11 octobre 12.
- SMITH, S. L., BURGESS, M. M., COMMISSION GÉOLOGIQUE DU CANADA. 2004. *Sensitivity of permafrost to climate warming in Canada*. [Ottawa], Geological Survey of Canada. viii, 24.
- SMITH, T.G., HAMMILL, M.O., 1981. *Ecology of the ringed seal, Phoca hispida, in its fast ice breeding habitat*. Can. J. Zool. 59: 966-981.
- SMITH, T.G., HAMMILL, M.O., 1980. *A survey of the breeding habitat of ringed seals, Phoca hispida, and a study of their behaviour during the spring hauling-out period on southeastern Baffin Island*. Can. Tech. Rep. Fish. Aquat. Sci. 1561. pp. 1-23.

- STANTEC, 2012. GEOTECHNICAL REPORT Proposed Wharf – Site 1. Deception Bay, Quebec 9 pages + annexes.
- STATISTIQUE CANADA. 2012. *Salluit, Québec (Code 2499135) et Kangiqsujuaq, Québec (Code 2499130)* (tableau). *Profil du recensement*, Recensement de 2011, produit n° 98-316-XWF au catalogue de Statistique Canada. Ottawa. Diffusé le 29 mai 2012. En ligne : <http://www12.statcan.gc.ca/census-recensement/2011/dp-pd/prof/index.cfm?Lang=F> Consulté le 18 septembre 2012.
- STATISTIQUE CANADA. 2007. *Salluit, Québec (Code 2499135) et Kangiqsujuaq, Québec (Code 2499130)* (tableau). *Profils des communautés de 2006*, Recensement de 2006, produit n° 92-591-XWF au catalogue de Statistique Canada. Ottawa. Diffusé le 13 mars 2007. En ligne : <http://www12.statcan.ca/census-recensement/2006/dp-pd/prof/92-591/index.cfm?Lang=F> Consulté le 19 septembre 2012.
- STANTEC. 2011. GEOTECHNICAL REPORT Proposed Wharf – Site 1. Deception Bay, Quebec 15 pages +annexes.
- SUSHAMA, L., LAPRISE, R. AND ALLARD, M. 2006. Modeled current and future soil thermal regime for northeast Canada. *Journal of Geophysical Research*, 11, D18111, 13 p.
- THERRIEN, J., PLOURDE, Y., TREMBLAY, B., PELLETIER, M., PARADIS, J. 2007. *Projet Nickélifère Raglan Sud – Inventaires complémentaires dans la baie Déception. Rapport sectoriel final – Étude d’impact sur l’environnement et le milieu social. Rapport de GENIVAR pour Canadian Royalties inc.* 92 p. et annexes.
- THIFFAULT, D., 2007. *Projet Nickélifère Raglan Sud – Milieu humain. Rapport sectoriel final – Étude d’impact sur l’environnement et le milieu social. Rapport de GENIVAR pour Canadian Royalties inc.*, 84 p. et annexes.
- TREMBLAY, M. FURGAL, C. 2008. *Les changements climatiques au Nunavik et au Nord du Québec: L'accès au territoire et aux ressources Rapport Final. Service des Ressources renouvelables - Administration régionale Kativik.* 99 pages+annexes.
- TURNER, S.J., S.F. THRUSH, J.E. HEWITT, V.J. CUMMINGS et G. FUNNELL. 1999. Fishing impacts and degradation or loss of habitat structure. *Fisheries Management and Ecology* 6 : 401-420.

XSTRATA NICKEL, 2012. *Mine Raglan – Accueil du site*. En ligne :
<http://www.xstratanickelraglan.ca/FR/Pages/default.aspx>
Consulté le 24 septembre 2012.

XSTRATA NICKEL, 2011. *Mine Raglan-Fact Sheet*. En ligne :
http://www.xstratanickel.com/EN/Publications/FactSheets/December%202011_Raglan%20FR.pdf. Consulté le 10 octobre 2012.

XSTRATA NICKEL, 2008. *Statistics Abitibi/Montréal/Québec*.

