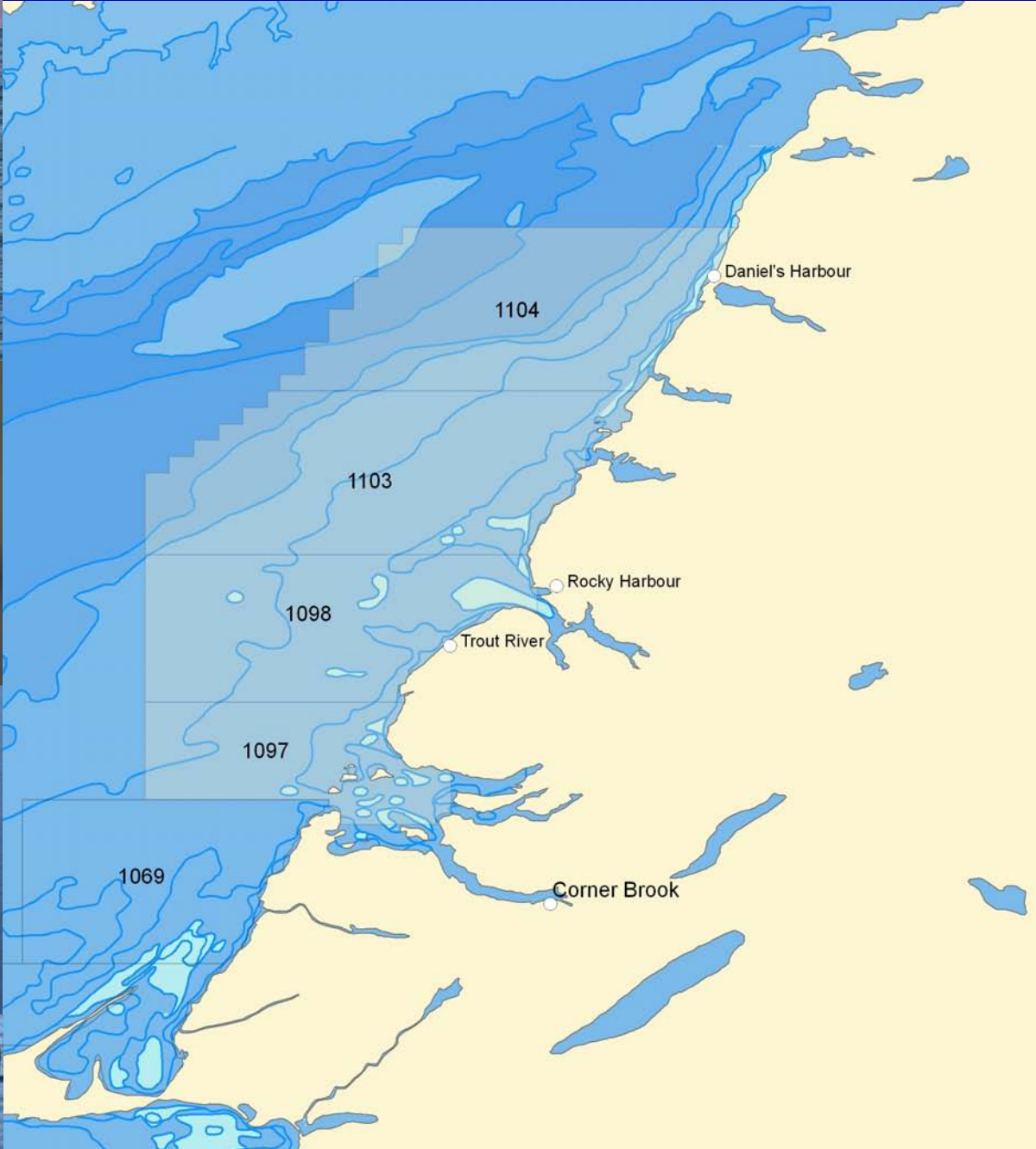


# ENVIRONMENTAL ASSESSMENT OF GEOPHYSICAL SURVEYS FOR EXPLORATION LICENCES 1097, 1098, 1103 AND 1104 WESTERN NEWFOUNDLAND



Prepared For: Canada-Newfoundland and Labrador Offshore Petroleum Board

Prepared By:



**NWest Energy Inc.**

St. John's, Newfoundland and Labrador





**ENVIRONMENTAL ASSESSMENT OF  
GEOPHYSICAL SURVEYS FOR EXPLORATION  
LICENCES 1097, 1098, 1103 AND 1104  
WESTERN NEWFOUNDLAND**



**St. John's, Newfoundland and Labrador**

**Prepared For:**

**Canada-Newfoundland and Labrador Offshore Petroleum Board**

**MARCH 2008**

**REF. NO. 50016 (2)**

This report is printed on recycled paper.

**Prepared by:  
Conestoga-Rovers  
& Associates**

31 Gloster Court  
Dartmouth, Nova Scotia  
Canada B3B 1X9

Office: (902) 468-1248  
Fax: (902) 468-2207

web: <http://www.CRAworld.com>

## EXECUTIVE SUMMARY

NWest Energy Inc (NWest) is planning to conduct a multi-year 3D marine seismic acquisition program, on its four Newfoundland Exploration Licences - ELs 1097, 1098, 1103 and 1104. Well site surveys and vertical seismic profile (VSP) surveys are also considered in this report although they will be undertaken during the exploration drilling phase. This Project is similar in nature to other seismic exploration programs assessed and conducted offshore Newfoundland. The total Project Activity Area is 3,115 km<sup>2</sup>, however, the seismic survey areas will be <1,000 km<sup>2</sup>. The program is proposed to take place between August and October in 2008 for the first seismic survey ( Option 2.1), and subsequent surveys being conducted from 2009 to 2015; the schedule will be discussed with commercial fishers on an annual basis. Surveys may be 20 to 30 day period with a 10 streamer towed arrangement or up to 75 days for a smaller four streamer arrangement. The survey direction will be in a northeast – southwest orientation.

As required by the *Canadian Environmental Assessment Act (CEAA)*, the EA Report addresses the requirements of Section 16 of *CEAA* and the environmental requirements developed by the Canada-Newfoundland and Labrador Offshore Petroleum Board (C-NLOPB). The EA Report focuses on seven valued environmental components (VECs) identified in relation to the Project:

- Marine and Migratory Birds
- Marine Fish and Shellfish;
- Marine Mammals;
- Sea Turtles;
- Species at Risk;
- Sensitive Areas; and
- Commercial Fisheries/Marine Traffic.

Discharges and emissions from the seismic vessel will include standard vessel solid and liquid wastes streams related to normal vessel activities, atmospheric emissions, light and noise emissions. All operational discharges and emissions will comply with the requirements of the Offshore Waste Treatment Guidelines, *Canada Shipping Act*, MARPOL and NWest's Environmental Protection Plan.

High intensity noise discharges from seismic surveys are considered to be the most likely activity to impact marine systems. Research carried out in 1994 by the Independent Scientific Review Committee, and commissioned by the Australian Petroleum Production Exploration Association and the Energy Research and Development Corporation, found that environmental issues relating to seismic surveys are largely concerned with:

- pathological effects (lethal and sub-lethal injuries) – immediate and delayed mortality and physiological effects to nearby organisms;
- behavioural change to populations of marine organisms;
- disruptions to feeding, mating, breeding or nursery activities of marine organisms in such a way as to affect the vitality or abundance of populations;
- disruptions to the abundance and behaviour of prey species for marine mammals, seabirds and fish; and
- changed behaviour or breeding patterns of commercially targeted marine species, either directly, or indirectly, in such a way that commercial or recreational fishing activities are compromised.

McCauley (1994) found that the response of Australian marine fauna to marine seismic survey noise ranged from no effect to various behavioural changes. McCauley found no evidence that the majority of marine species suffer any lethal or pathological effects as a result of noise from seismic surveys and concluded that “...given the relatively small scale of seismic activity, the often large scales over which biological events occur, the low probability of encounter between seismic surveys and ‘at risk’ populations at an appropriate time and place, then the wider implications of disruption by seismic surveys appear to be small for most species.”

The EA Report includes prediction of sound levels off horizontal based on spherical and cylindrical spreading transmission loss at various distances from the array source over water depths in the Project Area. Listed below are the observed effects on marine animals from sound levels and the distances those effects could be exhibited from the Project 3-D/2-D seismic surveys.

Species	Effects	Sound Level (RMS)	Predicted Distance From Source Over 150 m Water Depth	
			45°	0° Off Horizon
marine fish	transient stunning	192 dB re 1µPa	4 - 32 m	1 m
marine fish	internal injuries	200 dB re 1µPa	2-16 m	< 1 m
marine fish	egg/larval damage	220 dB re 1 µPa	1 m	<1 m
marine fish	mortality	230-240 db re 1µPa	<1 m	<1 m
marine mammals	temporary threshold shift	200-205 dB re 1 µPa	2- 6 m	1 m
cetaceans	harassment	180 dB re 1 µPa	16-128 m	1 m
pinnipeds	harassment	190 dB re 1 µPa	8-32 m	1 m
marine mammals	strong avoidance	160-170 dB re 1 µPa	64 m – 16 km	32 m
marine turtles	avoidance	166 dB re µPa	128 m – 4 km	32 m
marine turtles	erratic behaviour	175 dB re µPa	32 m – 1 km	8 m

This EA Report predicts that potential adverse environmental effects on the above VECs will be short term and range from localised to regional in extent. Avoidance effects are to occur at the further extent. The extent of potential physically harmful sound levels occurs within 1 m of the air gun source. Physical effects and space-user conflicts can be effectively mitigated through the application of technically feasible mitigation and standard offshore oil and gas industry health, safety, and environment procedures noted in this report. The significance of residual adverse environmental effects (*i.e.*, effects remaining after mitigation has been applied), including cumulative effects, is predicted to be not significant for all VECs. In summary, this environmental assessment predicts that NWest's proposed 3-D/2-D seismic surveys, well site surveys and VSP surveys can be conducted with no likely significant adverse effects on the marine environment of the west coast Newfoundland.

## TABLE OF CONTENTS

	<u>Page</u>
EXECUTIVE SUMMARY .....	I
1.0 INTRODUCTION .....	1
1.1 Purpose And Need For The Project .....	1
1.2 Proponent Information .....	3
1.3 Regulatory Context .....	4
2.0 PROJECT DESCRIPTION .....	6
2.1 Project Spatial Boundary .....	6
2.2 Project Temporal Boundary .....	9
2.3 Project Components .....	9
2.3.1 3-D And 2-D Seismic Survey .....	10
2.3.4 Well Site/Geohazard Surveys .....	13
2.3.5 Vertical Seismic Profile Surveys .....	14
2.4 Emissions And Waste Discharges .....	14
2.4.1 Noise Emissions .....	14
2.4.2 Air Emissions .....	21
2.4.3 Liquid Emissions .....	21
2.4.4 Solid Waste .....	22
2.5 Potential Malfunctions And Accidental Events .....	22
2.6 Health & Safety .....	23
3.0 ALTERNATIVES TO THE PROJECT & ALTERNATIVES FOR THE PROJECT .....	24
3.1 Alternatives To The Project .....	24
3.2 Alternative Means For The Project .....	24
4.0 ENVIRONMENTAL ASSESSMENT METHODOLOGY .....	26
4.1 Overview And Approach .....	26
4.2 Scope Of The Assessment .....	26
4.3 Issues Scoping And Valued Environmental Components .....	27
4.3.1 Stakeholder Consultation .....	27
4.4 Boundaries .....	30
4.4.1 Spatial Boundaries .....	30
4.4.2 Temporal Boundaries .....	32
4.4.3 Technical Boundaries .....	32
4.5 Potential Interactions, Issues And Concerns .....	33
4.6 Description Of Existing Conditions .....	33
4.7 Significance Criteria And Evaluation .....	34
4.8 Impact Analysis And Mitigation .....	34
4.9 Follow-Up And Monitoring .....	36
4.10 Cumulative Effects .....	36
5.0 ENVIRONMENTAL BASELINE .....	39
5.1 Marine Physical Setting .....	39
5.1.1 Seafloor Stratigraphy And Bathymetry .....	39

5.1.2	Subsurface Geology .....	41
5.1.3	Hydrocarbon Potential.....	41
5.1.4	Tectonics And Seismicity .....	42
5.1.5	Meteorology And Climate .....	42
5.1.5.1	Wind .....	45
5.1.5.2	At Sea Air Temperature .....	48
5.1.5.3	Visibility And Fog .....	48
5.1.5.4	Precipitation .....	49
5.1.6	Chemical And Physical Oceanography Setting.....	49
5.1.6.1	Water Temperature And Salinity .....	49
5.1.6.2	Waves .....	53
5.1.6.3	Currents .....	54
5.1.6.4	Tides .....	54
5.1.6.5	Ice .....	54
5.1.7	Noise Environment.....	58
5.2	Marine Resources .....	60
5.2.1	Plankton .....	60
5.2.2	Marine And Migratory Birds .....	61
5.2.3	Benthic Habitat.....	70
5.2.4	Marine Fish And Shellfish .....	72
5.2.4.1	Demersal Finfish .....	72
5.2.4.2	Pelagic Species .....	77
5.2.4.3	Shellfish.....	81
5.2.5	Marine Mammals.....	84
5.2.5.1	Pinnipeds .....	87
5.2.5.2	Cetaceans .....	87
5.2.6	Marine Turtles .....	89
5.2.7	Species At Risk .....	90
5.2.8	Sensitive Areas .....	94
5.3	Other Ocean Users .....	95
5.3.1	Commercial Fisheries .....	95
5.3.1.1	Seasonality .....	104
5.3.1.2	Northern Shrimp .....	104
5.3.1.3	Snow Crab.....	109
5.3.1.4	Lobster.....	113
5.3.1.5	Mackerel.....	113
5.3.1.6	Herring.....	114
5.3.1.7	Capelin .....	116
5.3.1.8	Turbot/Greenland Halibut .....	117
5.3.1.9	Halibut .....	123
5.3.1.10	Cod.....	124
5.3.2	Commercial Fishery Surveys .....	124
5.3.2.1	Sentinel Surveys.....	124
5.3.2.2	Research Vessel Surveys.....	125
5.3.2.3	Groundfish Enterprise Allocation Council .....	125
5.3.2.4	Snow Crab Survey .....	127
5.3.2.5	Halibut Tagging.....	127

5.3.2.6	Cod Reproductive Survey .....	127
5.3.3	Aquaculture .....	127
5.3.4	Marine Traffic .....	127
6.0	ENVIRONMENTAL EFFECTS OF PROJECT ACTIVITIES .....	132
6.1	Marine Birds And Migratory Birds.....	132
6.1.1	Boundaries .....	133
6.1.2	Potential Interactions And Issues .....	133
6.1.3	Significance Criteria And Evaluation.....	133
6.1.4	Effects Assessment And Mitigation .....	134
6.1.4.2	Vessel Presence .....	135
6.1.4.3	Vessel Discharge And Accidental Events .....	136
6.1.5	Cumulative Effects.....	137
6.1.6	Monitoring And Follow-Up .....	138
6.1.7	Summary .....	138
6.2	Marine Fish And Shellfish.....	139
6.2.1	Boundaries .....	139
6.2.2	Potential Interactions And Issues .....	140
6.2.3	Significance Criteria And Evaluation.....	141
6.2.4	Effects Assessment And Mitigation .....	141
6.2.4.1	Physical Effects.....	141
6.2.4.2	Behavioural Effects.....	147
6.2.4.3	Eggs And Larvae Development.....	149
6.2.4.4	Accidental Events .....	151
6.3	Cumulative Effects .....	152
6.3.1	Monitoring .....	154
6.3.2	Summary .....	154
6.4	Marine Mammals .....	155
6.4.1	Boundaries .....	155
6.4.2	Potential Issues.....	156
6.4.3	Significance Criteria And Evaluation.....	156
6.4.4	Effects Assessment And Mitigation .....	157
6.4.4.1	Physical Effects.....	157
6.4.4.2	Behavioural Effects.....	160
6.4.4.3	Vessel Presence .....	163
6.4.4.4	Accidental Events .....	164
6.4.5	Cumulative Effects.....	164
6.4.6	Monitoring And Follow-Up .....	165
6.4.7	Summary .....	165
6.5	Sea Turtles .....	167
6.5.1	Boundaries .....	167
6.5.2	Potential Issues And Interactions .....	167
6.5.3	Significance Criteria And Evaluation.....	167
6.5.4	Effects Assessment And Mitigation .....	168
6.5.4.1	Auditory Damage .....	168
6.5.4.2	Behavioural Effects.....	168
6.5.4.3	Vessel Presence .....	169
6.5.4.4	Accidental Events .....	169



6.5.5	Follow-Up And Monitoring .....	169
6.5.6	Cumulative Effects.....	170
6.5.7	Summary .....	171
6.6	Species At Risk.....	171
6.6.1	Boundaries .....	171
6.6.2	Potential Issues And Interactions .....	173
6.6.3	Significance Criteria And Evaluation.....	173
6.6.4	Effects Assessment And Mitigation .....	174
6.6.4.1	Marine And Migratory Bird Species At Risk.....	174
6.6.4.2	Fish Species At Risk.....	175
6.6.4.3	Marine Mammal And Sea Turtle Species At Risk.....	176
6.6.5	Follow Up And Monitoring.....	178
6.6.6	Cumulative Effects.....	179
6.6.7	Summary .....	180
6.7	Sensitive Areas.....	181
6.7.1	Boundaries .....	181
6.7.2	Potential Interactions And Issues .....	181
6.7.3	Significance Criteria And Evaluation.....	182
6.7.4	Effects Assessment And Mitigation .....	183
6.7.5	Follow-Up And Monitoring .....	184
6.7.6	Cumulative Effects.....	184
6.7.7	Summary .....	184
6.8	Commercial Fisheries.....	185
6.8.1	Boundaries .....	186
6.8.2	Potential Interactions And Issues .....	186
6.8.3	Significance Criteria And Evaluation.....	187
6.8.4	Effects Assessment And Mitigation .....	187
6.8.4.1	Space-Use Conflicts .....	187
6.8.4.2	Catchability Effects.....	188
6.8.5	Follow-Up And Monitoring .....	191
6.8.6	Cumulative Effects.....	191
6.8.7	Summary .....	192
7.0	EFFECTS OF THE ENVIRONMENT ON THE PROJECT .....	193
7.1	Meteorology And Oceanography .....	193
7.2	Sea Ice And Icebergs .....	193
8.0	ENVIRONMENTAL MANAGEMENT .....	194
9.0	SUMMARIES AND CONCLUSIONS .....	195
9.1	Zones Of Influence .....	195
9.2	Summary Of Mitigation And Follow-Up.....	195
9.2.1	Scheduling.....	198
9.3	Conclusions .....	199
10.0	REFERENCES.....	200

LIST OF FIGURES

Figure 2.1	Area of Interest for Geophysical Seismic Survey in 2008.....	8
Figure 2.2	Seismic Array Configuration.....	11
Figure 2.3	Far-field Signature for 2,620 cu.in Array .....	15
Figure 2.4	2,620 cu. in. Array Source Directivity Plots for Azimuth 0 Degrees (Inline) and 90 Degrees (Crossline) at Frequencies 0-150 Hz.....	18
Figure 4.1	Spatial Boundaries .....	31
Figure 4.2	Planned Seismic Programs .....	37
Figure 5.1	Quaternary Sediments.....	40
Figure 5.2	Bathymetry.....	43
Figure 5.3	Earthquake Epicenters.....	44
Figure 5.4	January Wind Rose .....	46
Figure 5.5	April Wind Rose.....	47
Figure 5.6	August Wind Rose.....	47
Figure 5.7	October Wind Rose.....	48
Figure 5.8	Salinity & Temperature (May) .....	50
Figure 5.9	Salinity & Temperature (August).....	51
Figure 5.10	Salinity at Depth.....	52
Figure 5.11	Average Vertical Temperature Distribution in NAFO 4R in August and February .....	53
Figure 5.12	Current Velocity & Moored Current Meters.....	55
Figure 5.13	Ice Break Up.....	57
Figure 5.14	Ambient noise spectra attributable to various sources (Wenz 1962).....	59
Figure 5.15	Vulnerable Pelagic Seabirds (January to March).....	64
Figure 5.16	Vulnerable Pelagic Seabirds (April to June).....	65
Figure 5.17	Vulnerable Pelagic Seabirds (July to September) .....	66
Figure 5.18	Vulnerable Pelagic Seabirds (October to December) .....	67
Figure 5.19	Nesting Sites and Wintering Locations.....	69
Figure 5.20	Marine Mammals.....	88
Figure 5.21	Sensitive Areas .....	96
Figure 5.22	Landing and Total of Admissible Catch by Year for Northern Shrimp in NAFO Division 4R.....	105
Figure 5.23	Shrimp Harvest Effort by Month in 4Rb,c ( 2004 - 2007) .....	105
Figure 5.24	Shrimp Fishery (April to November 2004-07).....	106
Figure 5.25a	Shrimp Fishery (2004-07) .....	107
Figure 5.25b	Shrimp Fishery( 2004-07) .....	108
Figure 5.26	Trends in Snow Crab TAC, Landings, and Fishing Effort in NAFO UA 4R.....	109
Figure 5.27	Catch Per Unit Effort of Snow Crab in 4R.....	110
Figure 5.28	Snow Crab Harvest Effort by Month in 4Rb,c ( 2004-2007) .....	110
Figure 5.29	Snow Crab Fishery (April to August 2004-07).....	111
Figure 5.30	Snow Crab Fishery (2004-2007).....	112
Figure 5.31	Location of Aboriginal Lobster Fishing.....	113
Figure 5.32	Mackerel Harvest Effort by Month in 4Rb,c ( 2004-2007).....	114
Figure 5.33	Seine Fishery (April to December 2004-07) .....	115
Figure 5.34	Herring Harvest Effort by Month in 4Rb,c ( 2004-2007).....	116
Figure 5.35	Capelin Harvest Effort by Month in 4Rb,c (2004-2007) .....	117

Figure 5.36	Seine Fishery (April to December 2004-07) .....	118
Figure 5.37	Gillnet Fishery (May to October 2004-07).....	119
Figure 5.38	Gillnet Fishery (2004-07) .....	120
Figure 5.39	Longline Fishery (April to October 2004-07).....	121
Figure 5.40	Longline Fishery (2004-07).....	122
Figure 5.41	Turbot Harvest Effort by Month in 4Rb,c ( 2004-2007).....	123
Figure 5.42	Halibut Harvest Effort by Month in 4Rb,c (2004-2007) .....	123
Figure 5.43	Cod Harvest Effort by Month in 4Rb,c ( 2004-2007) .....	124
Figure 5.44	Sentinel Surveys in the Gulf of St. Lawrence .....	125
Figure 5.45	DFO Research Vessel Surveys (August 2005-07).....	126
Figure 5.46	Aquaculture Sites.....	129
Figure 5.47	Shipping Lanes .....	130
Figure 5.48	Commercial Shipping: Traffic Density (2000).....	131
Figure 6.1	Sound Pressure Threshold (dB re 1 $\mu$ Pa) for the Onset of Fish Injuries.....	144

#### LIST OF TABLES

Table 1.1	NWest Exploration Licences Offshore Western Newfoundland .....	1
Table 2.1	Corner Coordinates for Seismic Survey 1 Area.....	7
Table 2.2	Known Seismic Survey Parameters for Option 2.1 .....	12
Table 2.3	Transmission Losses (TL) at Source in Peak Amplitude, RMS and Sound Exposure Level at 90° Azimuth and 0-90° From Vertical .....	19
Table 2.4	Predicted Sound Levels (RMS dB), 30° From Vertical Based On Spherical and Cylindrical Spreading Transmission Losses.....	20
Table 2.5	Predicted Sound Levels (RMS dB), 45° Off Vertical Based On Spherical And Cylindrical Spreading Transmission Losses.....	20
Table 2.6	Predicted Sound Levels (RMS dB), 90° Off Vertical Based On Spherical And Cylindrical Spreading Transmission Losses.....	21
Table 4.1	List of Stakeholders Contacted .....	28
Table 4.2	Selection of Valued Environmental Components .....	29
Table 4.3	Potential Project-Environment Interaction Matrix.....	33
Table 5.1	Wind Direction West Coast of Newfoundland .....	46
Table 5.2	Estimated Number of Nesting Pairs in Nesting Areas Within Important Bird Areas .....	63
Table 5.3	Marine Mammals Occurring in the Gulf of St. Lawrence.....	85
Table 5.4	Fish Species of Special Status Known to Occur in the Gulf of St. Lawrence.....	91
Table 5.5	Marine Mammals Species of Special Status that May Occur in the Affected Area.....	93
Table 5.6	Landed Weight of Domestic Harvest.....	98
Table 5.7	Commercial Harvest (Landed Value \$) From 2004 to 2007 Within the Project Area.....	102
Table 5.8	Monthly Landings of Main Fisheries Occurring in the Project Area (2004 to 2007) .....	104
Table 6.1	Summary of Environmental Assessment for Marine and Migratory Birds .....	138
Table 6.2	Summary of Behavioural Effects of Fish and Invertebrates from Nearby Air Sleeve Operations .....	147

Table 6.3	Summary of Environmental Assessment for Marine Fish and Shellfish.....	154
Table 6.4	Summary of Environmental Assessment for Marine Mammals.....	166
Table 6.5	Summary of Environmental Assessment for Marine Turtles.....	171
Table 6.6	Summary of Environmental Assessment for Species at Risk.....	180
Table 6.7	Summary of Environmental Assessment for Sensitive Areas.....	185
Table 6.8	Summary of Environmental Assessment for Species at Risk.....	192
Table 9.1	Predicted Zones of Influence and Direct and Indirect Effects on Marine Species Expected in the Affected and Regional Areas at 0° and 45° Angles of Emission.....	195
Table 9.2	VEC-Specific Mitigative Measures and Follow-Up.....	196
Table 9.3	Schedules of Important Commercial Fishing Activity and Ecologically Important Species in the Project Area.....	198

LIST OF APPENDICES

APPENDIX A	THE LEACH'S STORM-PETREL: GENERAL INFORMATION AND HANDLING INSTRUCTIONS
APPENDIX B	REPORT OF MIGRATORY BIRDS SALVAGED
APPENDIX C	STANDARDIZED PROTOCOLS FOR PELAGIC SEABIRD SURVEYS FROM MOVING PLATFORMS
APPENDIX D	ENVIRONMENTAL STEWARDSHIP PLAN

## 1.0 INTRODUCTION

NWest Energy Inc. (NWest) acquired four exploration licences (ELs), located offshore western Newfoundland - ELs 1097, 1098, 1103 and 1104. Two of these licences were issued on January 15th, 2006, and two additional licences were successfully acquired on January 15th, 2007. These exploration licences were issued by the Canada-Newfoundland and Labrador Offshore Petroleum Board (C-NLOPB). The total area of the combined licences is 659,880 hectares (1,630,599 acres). A summary of the exploration licences is presented in Table 1.1 below.

**Table 1.1 NWest Exploration Licences Offshore Western Newfoundland**

Area	Interest (%)	Gross Hectares	Net Hectares
<b>Working Interests</b>			
Block 1097	100	96,100	96,100
Block 1098	100	159,872	159,872
Block 1103	100	216,164	216,164
Block 1104	100	187,744	187,744
<b>Total, Unproved Properties</b>		<b>659,880</b>	<b>659,880</b>

Sources: Geophysical Interpretation, Resource Assessment, and Valuation of Certain Exploration Licence Blocks, Offshore Western Newfoundland for NWest Energy Inc., Sproule Associates Limited.

NWest proposes to undertake a geophysical 3-D seismic survey program on NWest's landholdings on the west coast of Newfoundland and Labrador commencing in the third quarter of 2008. There is also the potential for 2-D surveys on the licences and geohazard surveys in areas of interest. This environmental assessment (EA) for the program will also address vertical seismic profiles which is an activity related to drilling exploration, but due to its seismic nature will be assessed in this EA. In total, seismic-related activities could potentially extend over an eight year period, as required.

### 1.1 Purpose And Need For The Project

The purpose of NWest's proposed seismic survey program is to help assess and delineate further the potential for the discovery of gas and oil reserves offshore the west coast of Newfoundland. With regard to location, survey lines will be selected based on existing understanding of the geological conditions within the areas of interest and are intended to test geological concepts. Having acquired existing 2-D seismic data, NWest still requires additional information through a series of 3-D seismic survey to allow the

identification and delineation of potential resources before decisions can be made to pursue them further through exploration drilling. The seismic program proposed to commence in 2008 will add important delineation data, and enhance NWest understanding of the complex structures offshore Newfoundland's west coast. Areas to the south, Port au Port Peninsula, have proven commercial hydrocarbon reserves.

To date, seismic surveys is the most effective and reliable means of assessing potential hydrocarbon areas in marine settings and the technology has been, and is, consistently used throughout the world, including northern and eastern Canada.

This Project is a necessary step in allowing NWest to maximize returns to shareholders and in fulfilling work commitments related to its licencing agreements with the C-NLOPB. Furthermore, exploration, development, and production of oil and gas resources contribute to the provincial and federal economies by providing new business opportunities within the region, through large capital and operating expenditures, transfer of technology, providing employment opportunities, and generating royalties to government.

Increasing offshore petroleum exploration has been identified as a priority of the Government of Newfoundland and Labrador. On September 11, 2007, the government of Newfoundland and Labrador released its long awaited Energy Plan. The plan addresses the energy direction for the province over the next several decades. In 2007, Newfoundland and Labrador is expected to produce almost 45 per cent of Canada's conventional, light crude oil.

*The Energy Plan (2007) states "While many of our offshore and onshore areas are now being actively investigated, it is essential that we encourage seismic and exploration activity in all basins to maintain a high level of industry interest. Without new exploration, there can be no new developments other than those already discovered. The keys to advancing our oil and gas sector are to encourage additional exploration activity and to manage the development of these resources so that investors can earn a fair return while the province maximizes the benefits it receives from these resources.*

*To fill in these important gaps in our offshore knowledge, the Provincial Government will make an initial investment of \$20 million over the next three years through the Energy Corporation to purchase existing proprietary seismic data for reevaluation and acquire new data. In the oil and gas industry, new opportunities are often identified through this process. The acquisition of quality seismic data facilitates the evaluation of exploration risk in new areas. This information plays a key role in attracting exploration and development capital.*

*The Provincial Government recognizes the importance of an efficient and effective data management system for both the offshore and onshore petroleum sectors. We are currently making a substantial investment in the development of an offshore data management repository within the C-NLOPB. We will assess the appropriate approach for the storage and collection of onshore information, including whether synergies can be achieved by incorporating the data into the C-NLOPB repository.*

*The Provincial Government is also committed to working with industry to develop regulatory and fiscal measures to increase exploration activity. The acquisition of seismic data, and the encouragement of exploration through regulatory and fiscal measures, are areas where the Federal Government has the opportunity to invest further in the province's oil and gas industry. The Provincial Government realizes that companies need to understand the structure of the regulatory and fiscal regimes prior to making specific exploration decisions. This Plan provides direction as to what the royalty and regulatory structure will be as we move forward.*

*We need to educate the world petroleum industry about the resources off our shores. This will require continued and enhanced efforts to market the potential of these resources and our ability and capacity to participate in developing them.*

*Newfoundland and Labrador's energy sector contributes more to this province's real Gross Domestic Product (GDP) than any other. In 2006, the energy sector's contribution to the Newfoundland and Labrador economy (as a percentage of total real GDP) exceeded that sector's contribution in all other provinces, including Alberta. The energy sector not only generates significant revenues, but is a major employer in our province. This employment activity is expected to increase dramatically over the next several years, which will present us with the challenge of having enough skilled trades people and other qualified professionals to support this growth."*

Similarly, the new provincial innovation strategy (Innovation Newfoundland and Labrador: A Blueprint for Prosperity, 2006) recognizes the continued development of our offshore resources as a key element for future growth and an important strategic building block for expansion in related knowledge-based fields.

## **1.2 Proponent Information**

NWest is incorporated as a private Canadian Corporation. The Corporation is focused on the exploration, acquisition and advancement of oil and gas properties primarily along the west coast of Newfoundland and Labrador, Canada. NWest's Operating Licence granted by the C-NLOPB is 0716.

NWest was formed to participate in the upstream oil and gas business, primarily in Eastern Canada along the west coast of Newfoundland and Labrador. The strategy of the corporation is to add shareholder value through the acquisition, exploration and development of oil and gas properties. Concurrently, the corporation is planning an exploration program with the view of discovering oil and gas reserves that can be brought to the market. In the fall of 2006, NWest retained the specialized services of Sproule Associates Limited to undertake a technical review and valuation of NWest's exploration licenses. The principal objectives were to interpret the existing seismic data and conduct a resource assessment of the company's blocks. With this initial assessment completed, NWest is focused on the planning and execution of a 3-D seismic program.

Corporate contact information is as follows:

Francois Gauthier – CEO  
NWest Energy Inc. Head Office  
10 Fort William Place  
Baine Johnston Centre  
P.O. Box 566, Stn C  
St. John's, Newfoundland and Labrador  
A1C 5K4  
Phone: 1-709-722-3757  
Mobile: 1-709-765-7755  
fgauthier@nwestenergy.com

Blair MacDougall – Project Manager  
Phone: 1-709-722-3757  
Mobile: 1-709-765-5459  
bmacdougall@nwestenergy.com

### **1.3 Regulatory Context**

In accordance with its mandate under the *Canada-Newfoundland Atlantic Accord Implementation Act*, the C-NLOPB may issue an Authorization to Conduct a Geophysical Program to allow NWest to carry out the seismic survey program described herein. Offshore geophysical surveys (including geohazard surveys) on federal lands are subject to screening under the *Canadian Environmental Assessment Act (CEAA)*. In addition, Section 19.1 (a) of the *CEAA's* Inclusion List Regulations identifies those projects relating to seismic surveys for which a screening level of assessment is required. Under Part II



Oil and Gas Projects, physical activities that require an authorization referred to in paragraph 138(1)(b) of the *Canada-Newfoundland Atlantic Accord Implementation Act* and relate to a marine or freshwater seismic survey during which the air pressure measured at a distance of one metre from the seismic energy source is greater than 275.79 kPa (40 psi) requires completion of an environmental assessment.

The C-NLOPB is the designated federal representative mandated under the *Atlantic Accord Implementation Act* and the *CEAA*. The C-NLOPB acts as the federal environmental assessment coordinator in this context. Because seismic survey activities have the potential to affect seabirds, marine mammals, and fish and fisheries, both Fisheries and Oceans and Environment Canada are the primary federal agencies with interests and expertise in the environmental aspects of the proposed program. Relevant government regulations and guidelines to be reviewed during the issues scoping process will include:

- Canada-Newfoundland Atlantic Accord Implementation Act
- Canadian Environmental Assessment Act
- Fisheries Act;
- Oceans Act
- Migratory Birds Convention Act and Regulations;
- Canadian Environmental Protection Act;
- Committee on Endangered Wildlife in Canada (COSEWIC)
- Species at Risk Act
- Navigable Waters Act
- Canada Shipping Act
- Offshore Waste Treatment Guidelines (NEB *et al.* 2002); and
- Geophysical, Geological, Environmental and Geotechnical Program Guidelines, (C-NLOPB 2004)

As per the C-NLOPB Geophysical, Geological, Environmental and Geotechnical Program Guidelines (April 2004), an approval to conduct the planned survey must be obtained from the C-NLOPB.

## 2.0 PROJECT DESCRIPTION

NWest proposes to undertake a geophysical 3-D seismic survey program on their landholdings off the west coast of Newfoundland using conventional technology. The contracted seismic survey vessels will tow a sound source (air source array) and streamer(s) composed of receiving hydrophones. There is the potential for 2-D surveys on the licences and geohazard surveys in areas of interest. Vertical seismic profiling (VSPs), which is an exploration drilling activity, and not a towed array, is also included in the environmental assessment to address all petroleum exploration seismic-related activities.

NWest's holdings lie offshore along the western coast of Newfoundland between Corner Brook to the south and Port au Choix to the north. In this area, a thick Late Proterozoic to Ordovician sedimentary package, consisting of shallow marine to nearshore carbonate and clastic facies and co-eval deeper marine mudstone dominated facies, was deposited on the passive margin of the continent. Taconic, Salinic and Acadian crustal plate convergence and associated deformation have juxtaposed high quality source rocks with potential reservoir facies, creating structurally enhanced and possibly hydrocarbon-charged stratigraphic and structural traps in the present-day onshore and nearshore areas.

Oil seeps in the area have been observed as early as 1812 and sporadic hydrocarbon exploration has continued in the area for at least 165 years. To date, all hydrocarbon samples analyzed appear to have been generated in pre-Devonian clastic source rocks from Type I/II organic (mostly algal) matter. Shales within the Green Point Formation, having a total organic content up to 10.35 percent, have been recovered, and are considered as marginally mature to mature source rocks. Thermal maturity increases to the north, along the holdings.

### 2.1 Project Spatial Boundary

The first NWest seismic survey (Seismic Survey Option 2.1) will cover an approximate area of 779 km<sup>2</sup> and will commence in August 2008, pending vessel availability. This survey is within a larger Project Activity Area (PAA) within which NWest expects to undertake additional future seismic surveys and associated seismic-related drilling activities. The general coordinates of the application area are:

Northern Boundary  
5578000mN

Southern Boundary  
5450000mN

Western Boundary  
370000mE

Eastern Boundary  
1.5 to 5 nautical miles (3 to 8 km) from coastline

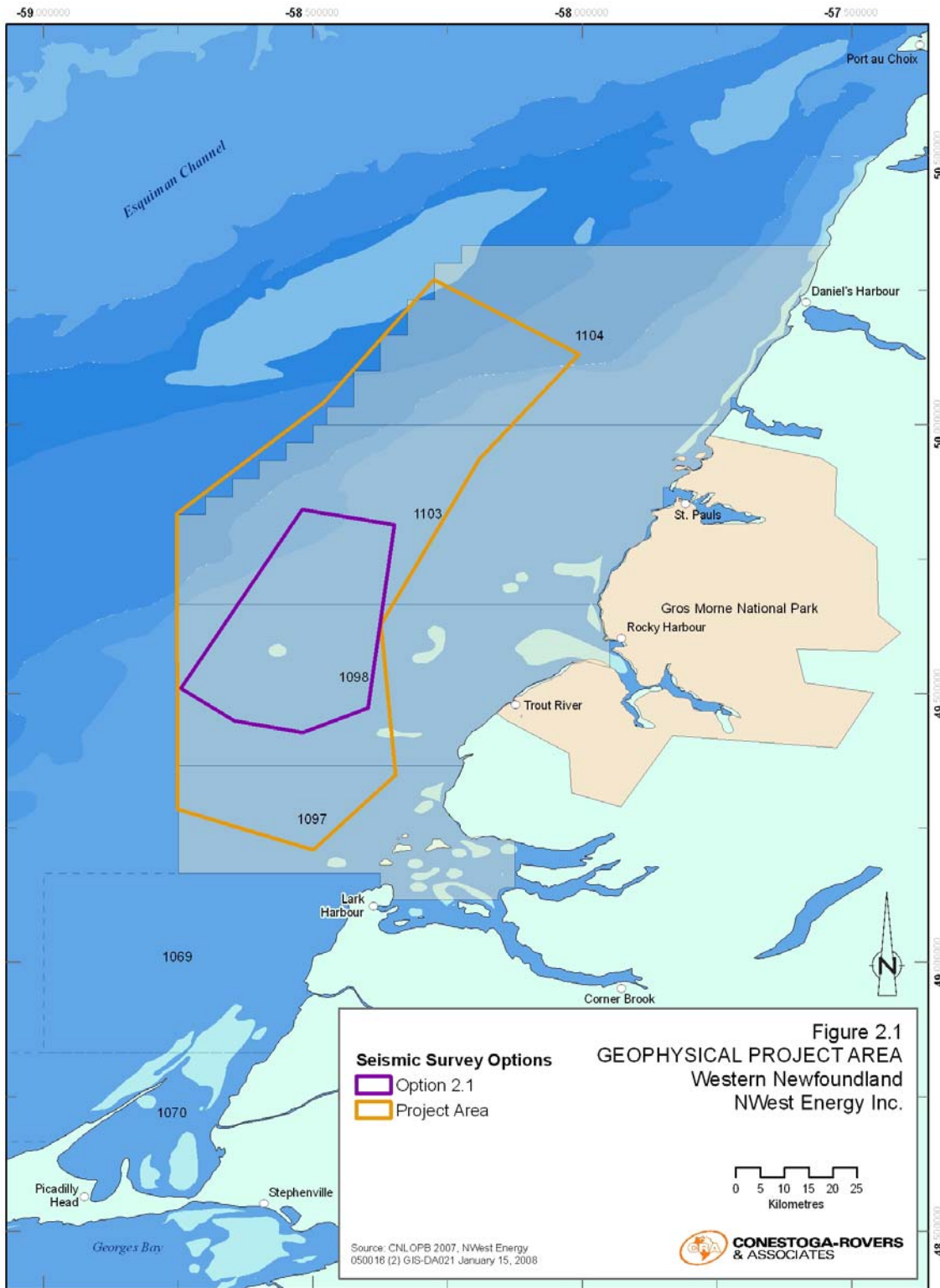
The PAA is shallow to mid-water range in depth, extending from 40 metres depth about nine kilometres at the closest point from shore to 350 metres depth at the furthest boundary of the blocks.

Seismic Survey Option 2.1 will be conducted over the area of interest as depicted in Figure 2.1. Future surveys within the PAA are not planned to duplicate previous surveys.

**Table 2.1 Corner Coordinates for Seismic Survey 1 Area**

<b>UTM E Z21 NAD83</b>	<b>UTM N Z21 NAD83</b>	<b>Lat NAD83</b>	<b>Long NAD83</b>
410140.00000	5562800.00000	50.210550	-58.259380
428070.00000	5553720.00000	50.131351	-58.006423
414540.00000	5532150.00000	49.935598	-58.190883
405250.00000	5520970.00000	49.833668	-58.317565
392000.00000	5533750.00000	49.946334	-58.505323
396175.00000	5545850.00000	50.055868	-58.450421

Geohazard surveys will be conducted on areas of drilling interest in advance of exploration drilling. During drilling operations, vertical seismic profiles (VSPs) may be conducted at the well sites. These latter two seismic activities could occur following the 3-D (and possibly 2-D) seismic surveys.



**Figure 2.1 - Area of Interest for Geophysical Seismic Survey in 2008**

Note:

- Coordinates UTM Zone 21, NAD 83;
- Exact survey area to be finalized when a seismic acquisition company has been chosen;
- Cost and vessel availability may impact survey area;
- Survey area will have an allocation for seismic vessel turn radius;
- Geohazard surveys and VSPs on drilling locations may be conducted in the survey area as well.

## **2.2 Project Temporal Boundary**

By August 1, 2008, NWest proposes to commence the first 3-D survey covering Survey Area Option 2.1. Later seismic surveys over the PAA may occur between May 1 and November 30 over the next eight years (2008 to 2015). Due to ice conditions and weather, the optimal time for seismic operations is between late May to December. The maximum wave height for operations is three metres (Sea State 5) as wave noise interferes with the data quality and operational safety becomes an issue.

Each 3-D seismic survey will require between 20 to 30 days to complete using a 10 streamer seismic vessel and 65 to 75 days to complete using a 4 streamer vessel. Well site survey data acquisition typically requires only 3 to 5 days for a 2 x 2 km area and often last less than three days. Typically VSP surveys are completed in 9 to 15 hours.

NWest acknowledges that the scope of the Project to be assessed in the EA Report extends over several years, during which time the regulatory, biophysical, and socio-economic environment may change from that assessed in this report. NWest will periodically review the EA Report, as directed by the C-NLOPB, for current applicability, will continue stakeholder consultations, and will work with regulatory authorities to ensure that the EA remains fit for purpose.

No seismic vessel has been retained at this juncture. A procurement process commenced in June 2007 to retain a suitable seismic vessel. In the interest of cost savings, opportunities will be sought to cooperate with other operators conducting seismic programs within the same time frame.

## **2.3 Project Components**

The following description of program components addresses the range of activities that may be used through the various geophysical exploration phases:

- 3-D and possibly 2-D Seismic Survey
- Well Site Survey
- Vertical Seismic Profiling

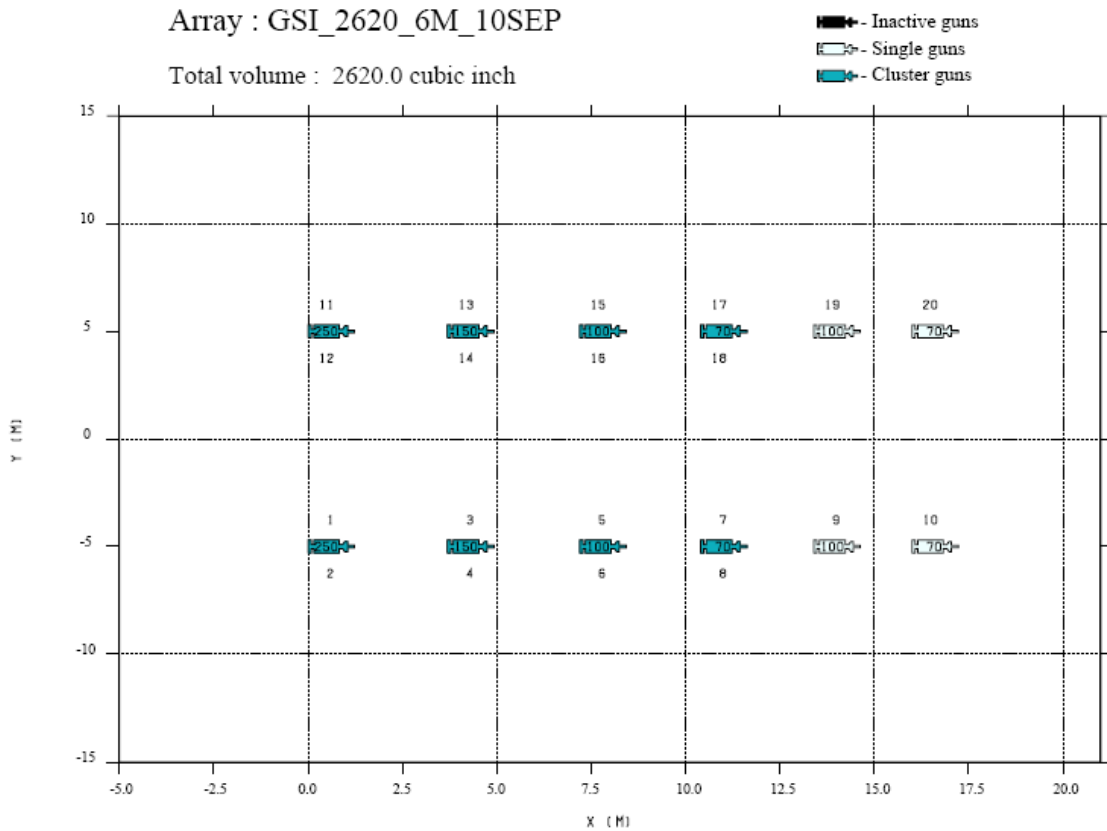
### **2.3.1 3-D And 2-D Seismic Survey**

Marine seismic surveys for petroleum exploration use arrays of air source units as the source of seismic signals. The components of a 3-D and 2-D survey include a seismic vessel (not yet selected at this time), the source towed array (air source units); the receiver (hydrophone) towed array; and a support chase vessel. The technical specifications for the survey and for the 3-D parameters will be finalised when the Geophysical Contractor has been selected. The energy source will be a dual air source array system. An air source unit is essentially a stainless steel cylinder charged with high-pressure air. Despite the term, no explosive devices are incorporated. The seismic signal is a popping sound created when air is released forcefully into the water column. The streamers are towed behind the vessel to receive the sound source from the air source as it reflects from and within the seafloor.

For the 2-D survey, ships are usually about 60-90 m long and tow a single source array 100 to 200 m behind the ship. Each source array is about 20 m long and 24 m wide. Following 100 to 200 m behind the source array is a single streamer between 8 to 12 km long. A tail buoy with radar reflectors is attached at the end of each streamer. The survey pattern entails the ship sailing down a track from 12 to 20 hours depending on the size of the survey area. At the end of the track, the ship will take two to three hours to turn around and start along another track. Spacing between tracks is about two kilometres.

A conventional 3-D seismic vessel is typically 80 to 90 m long, slightly longer because they tow more gear. These ships usually tow two source arrays at equal distance, 100 to 200 m behind the ship. Following at this distance are the 6 to 12 streamer cables of 3 to 8 km long and spread out over a width of 600 to 1,500 m. Vessel speed will be approximately 4.5 kn when the survey gear is deployed, similar to trawling fishing vessels. About every 16 seconds the air gun array is fired. Typical survey vessels are capable of cruising at 10 kn while in transit (with gear onboard). During the survey, the ship sails along a track from 12 to 20 hours depending on the size of the survey area. Reaching the end of the track will take two to three hours to turn around. It is estimated that the survey vessel will require a turning radius of 10 kilometres outside the identified survey area. Seismic operations can generally continue up to a Sea State of 5 or wave heights of about 3 m.

The marine seismic air source array source has a total volume of 2620 cu. in. consisting of 20 air source units (type Bolt, Sodera-G or Input-output Sleeve Gun II air guns) operating at 2,000 psi. For each air source unit, the amplitude (or loudness) of the seismic signal is a function of the volume and pressure of the air inside the cylinder and the cylinder's depth under the water surface. The larger the cylinder volume and the higher the internal air pressure, the louder the sound. The individual source unit volumes range from 70 cu. in. to 250 cu. in (Figure 2.2). Table 2.2 summarises the survey acquisition parameters.



**Figure 2.2 Seismic Array Configuration**

The larger source units are positioned at the front of the array with progressively smaller volumes to the back of the array. Each array will fire every seven seconds.

**Table 2.2 Known Seismic Survey Parameters for Option 2.1**

Total Linear Length of Lines (km)	2,000 to 3,000 km
Number and Length of Streamers	6 to 8 x 6,200 m
Group Interval	12.5 m
Streamer Separation	700 m maximum spread; 100 m between each
Air Source Arrays	2 air source arrays, 0.05 to 0.08 m <sup>3</sup> in total volume (2620 cu. in.)
Air Source Operating Pressure	138 bar (2,000 to psi)
Source Interval	25 metres
Source pressure	2,000 psi
Hydrophones	4 to 8 in total, towed 5 to 6 km behind vessel
Record Length	7 secs
Source Array Tow Depth	6 m
Receiver Array Tow Depth	4 to 8 m
Vessel Speed	4 knots while recording, 10 knots in transit
Turning Radius	10 km

A soft start approach would occur at the beginning of a new line within the perimeter or at the start of operations anywhere within the program area.

Details of logistical operations to support the subject geophysical program will largely depend on seismic acquisition company, season and weather.

### **Helicopters**

Helicopters may or may not be utilized depending on type of helicopter available and seismic vessel procured. For the duration of the seismic program, it is possible that the fleet of helicopters available out of St John's will be Sikorsky S-92's only. The implication of this is that many of the seismic vessels currently available on the market are not capable of allowing S-92's to land on their helideck. Super Pumas or equivalent are the only type of helicopter potentially available that are approved for landing on the helidecks of the anticipated seismic vessels.

### **Shore Base**

Due to the location of the planned geophysical survey area, it is possible a shore base and supply area will be staged out of the west coast region or Avalon Peninsula. A final decision cannot be made on this issue until a seismic vessel company is chosen.

### **Support Vessels**

Supply vessels may be utilized for crew changes and supply of materials and consumables. Also, it is possible the seismic vessel may interrupt its geophysical program for logistical requirements. Again, final determination on these points can only



be made when a seismic vessel company is chosen as well as the season of operations is known.

The vessels incorporate a chase boat that scouts for other vessels or fishing gear that may interact with the survey while underway. The bridge crew on the seismic vessel maintains close surveillance of approaching vessels. Radar reflectors are attached to the streamers for detection by other vessels.

#### **2.3.4 Well Site/Geohazard Surveys**

It is possible that a well site geohazard survey will be conducted at one or more locations within the geophysical survey area over the next eight years. A high resolution site survey is undertaken to study the shallow subsurface for geohazards, soil conditions, and potential archaeological features (*i.e.* ship wrecks). NWest will communicate any plans to the C-NLOPB if a well site geohazard survey becomes a part of the geophysical program. A typical wellsite survey uses the following acquisition equipment:

- survey vessel;
- side-scan sonar;
- sub-bottom profiler and echosounder;
- multichannel seismic; and
- magnetometer.

The survey vessel for well site surveys tends to be a smaller ship than what is used for the 3-D and 2-D seismic programs because the capacity to store, extend and retrieve long and multiple cables is not required. An offshore supply-style vessel (about 60 metres) is typically used in Atlantic Canada for such surveys.

Typically, the survey vessel will trail an air gun about 25 m behind the ship and tow one streamer of approximately 600 metres in length with a tail buoy. The air source array that is used is much smaller than traditional 3-D and 2-D seismic arrays and is usually <200 cu. in., which produces a higher frequency and lower power signal. The ship travels at about 3 kn (5.6 km/hr) and the air gun is fired every 12.5 m (about every 7 to 8 seconds). Typically the ship steams in one direction for about one hour, then turns around over a 20 to 30 minute period and surveys the next track. Including line turns, the time to survey one block is about 36 to 48 hours.

### **2.3.5 Vertical Seismic Profile Surveys**

During exploration drilling, vertical seismic profile (VSP) surveys of each proposed exploration well may be required. It is estimated that each VSP could take place within a radius of 2.5 km from each well site. The number of well sites is not known at this stage. The VSP survey collects seismic data from sensors placed in a borehole with seismic sources deployed in various geometries around the vertical array of sensors.

VSP surveys are typically acquired using a cluster of small to medium size air sources (total volume of 450 to 1500 cu in) and a peak pressure of 240 to 250 dB re 1 $\mu$ Pa at 1m (Davis *et al.* 1998). No streamers are deployed for these kinds of surveys. For zero offset surveys, a small volume single air gun is typically deployed from the drill rig. Walk-away surveys are deployed from a vessel (typically an offshore supply vessel), use four to eight air guns, and are fired in a pattern all around the drilling platform but rarely more than 500 m away. The guns will be charged with nitrogen or compressed air at 2,000 psi and suspended at a constant depth of four to seven metres, depending on sea-state. VSP surveys are usually a one-time event and take one day. For the zero offset survey, the air guns are fired four to eight times for 20 seconds, followed by five to twenty minute quiet time during which the sensor string is raised. This procedure is repeated until the survey is completed.

## **2.4 Emissions And Waste Discharges**

The vessels and towed array will generate noise. The vessels also generate atmospheric, liquid and solid waste. Discharges and emissions from this program will be similar to those of any standard marine vessel. They will be minor. These emissions and discharges are described below.

### **2.4.1 Noise Emissions**

#### **Signals**

The firing of an air source generates an oscillating bubble in the surrounding water. At the time of firing, the pressure of the air inside the cylinder far exceeds the outside pressure in the surrounding water. This difference in pressure causes a bubble to rapidly expand in the water around the air source. It is this initial bubble expansion that generates the relatively broadband seismic pulse.

The output of an air source array is in terms of time vs pressure and frequency. The frequency characteristics of an air source array signature relate to how the signal sounds. Hertz (Hz) is the unit of measure for frequency. Air source signatures are called broadband, as they contain a whole range of frequencies. The produced broadband source level for this array is about 252 dB re 1  $\mu$ Pa-m, with the highest energies falling between 10 to 100 Hz. For the purpose of evaluating the environmental impact of an air source, the signature should be reported at the widest bandwidth. The air gun array signature for the 2,620 cu. in. array is shown in Figure 2.3. The initial positive peak is followed by a negative trough and the sound pressure level pulse maximum is 42 bar-m.

Far-field signature of array : GSI\_2620\_6M\_10SEP

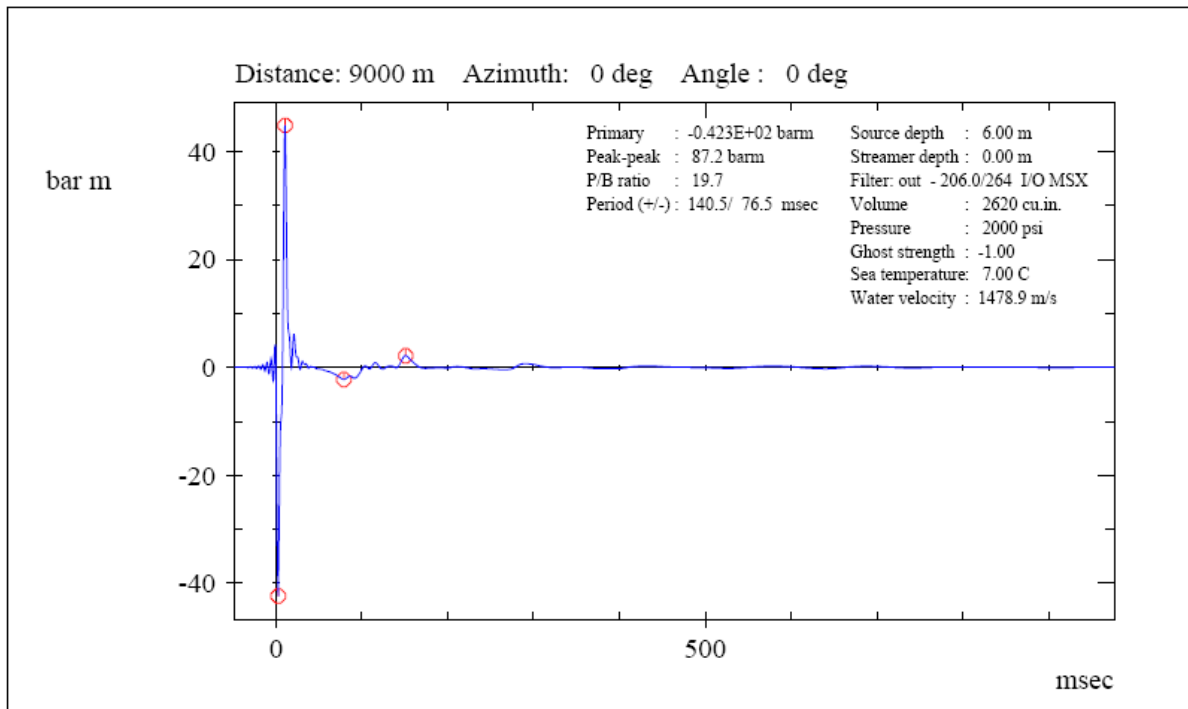


Figure 2.3 Far-field Signature for 2,620 cu.in Array

Sound decreases with distance from the source. This is referred to as transmission loss and it is influenced by geometric spreading loss and attenuation. Pressure measured at some distance away for the air source array is determined by using the model of spherical and cylindrical spreading. Sound travels out in a progressively large area from the sound source in all directions. This unrestricted spreading in water is called spherical spreading. The loss of sound is described as  $20\log R$  dB, where R is distance from the source in metres. This calculates to a transmission loss of about 6 dB with each doubling of distance from source. As in the example to follow, if the array output is 225

dB re 1 uPa at 1 m, the source pressure would decrease to about 219 dB at 2 m, to 213 dB at 4 m, etc. However, this is too simplistic as there are many factors that contribute to decay a sound wave, including frequency, local conditions such as water temperature, water depth and bottom conditions. The sound can be compressed between the sea surface and the seafloor and other obstructions (*e.g.* thermal layers), thus channeling it. Therefore, sound spreads in a cylindrical fashion. The transmission loss half that of spherical and is then described as  $10\log R$  dB, a loss of about 3 dB with each doubling of distance.

In areas of very strong acoustic contacts at the seafloor (*i.e.* bedrock), much of the acoustic signal will be reflected back into the water column, and there will be lower decay rate with distance than expected. As these surveys map subsea structures, in most cases the seafloor conditions will be transparent to the low frequency seismic signals and the variation in seafloor sediment (sand, gravel, silt) will not have a significant effects on sound propagation from seismic surveys.

The sea surface acts as a mirror for sound waves causing ghost reflections of the real source. These two signals cancel each other out at the sea surface. This effect can result in rapid decay of the waterborne seismic signal.

The conditions above describe how seismic signal loses energy and results in stronger attenuation of the seismic signals over distance. There are some conditions that cause lower energy decay, the most noted is sound channels. Sound can be trapped between geological layers but these are subsurface conditions. Sound channels in the sea are formed by temperature and pressure which changes sound propagation velocity. Sound channels act as ducts that can focus sound energy and attenuation is much less than normal for spherical spreading. The sound can travel considerable distance. Sound channels can be complex, there are shallow water sound channels, deep water sound channels and mixed layer sound channels.

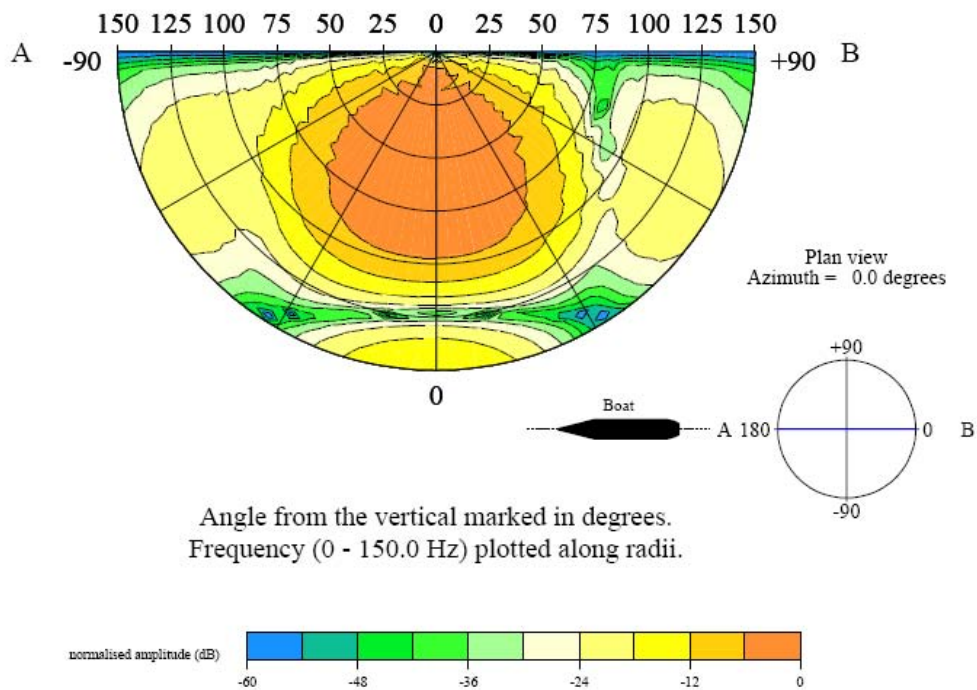
### **Source Directivity**

The array is configured in such a way as to maximize the amount of seismic energy projected vertically into the geologic formation being surveyed. Although the direction of the greatest sound intensity is directed vertically downwards from the array, some energy is radiated in directions away from the beam axis and into the surrounding environment. Because of the pattern of air source placement in an array, the signature changes as a function of direction (azimuth) and emission angle (angle from the vertical). The firing times for all the air source *s* in the array are synchronized to ensure that the primary pulses from each gun align exactly with one another along the vertical axis of the array.

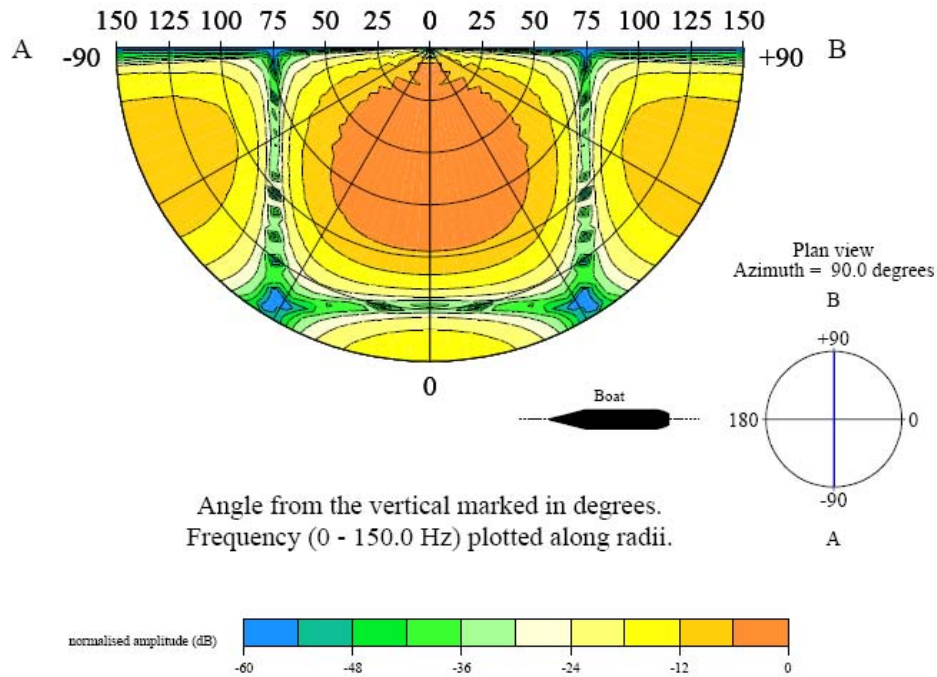
These differences in the array signature with respect to direction and angle from the vertical are referred to as the array response. It means that the "sound" (*i.e.*, frequency content) and "loudness" (*i.e.*, pressure strength) of the array signature will be different at different locations in the water. These differences are known as the acoustic radiation pattern and can be mapped in three dimensions.

The array output plots broadband pressure distribution at various distances away from the array. It is important to analyze how different frequencies are emitted as a function of azimuth and emission angles. The following plots shows the acoustic radiation emitted for different frequencies from a 2,620 cu. in. (Figure 2.4) air source array in the vertical plan along the inline (front to back of vessel) and crossline (port to starboard of vessel) axes of the array. The 100 Hz frequency is of most concern since the peak pressure occurs at that frequency.

Source Directivity Plot - azimuth : 0.0 degrees - array GSI\_2620\_6M\_10SEP



Source Directivity Plot - azimuth : 90.0 degrees - array GSI\_2620\_6M\_10SEP



**Figure 2.4 2,620 cu. in. Array Source Directivity Plots for Azimuth 0 Degrees (Inline) and 90 Degrees (Crossline) at Frequencies 0-150 Hz**

Most of the broadband energy is concentrated close to the vertical. Emissions at frequencies above 300 Hz are highly attenuated along radiation paths away from the vertical. When comparing the radiation plots it can be seen that there is more high frequency energy emitted side-ways from the array than from front-to-back. When the peak pressure amplitude and frequency emission plots are reviewed together the following summary statements can be made about the direct air source pressure pulses propagating through the water column:

1. Most of the broadband energy emitted from the air source array is concentrated close to the vertical emission angle.
2. In the array's near-field, pressure amplitudes will be significantly less than predicted from point source extrapolation (by as much as -20 dB *i.e.*, 1/10<sup>th</sup> reference).

3. The pressure amplitude rapidly diminishes at emission angles greater than 45 degrees.
4. Coherent high frequency energy generated by air source arrays is generally less than 300 Hz.

**Transmission Loss and Sound Attenuation**

The projected energy and horizontal propagation (transmission loss) at source for the 2,620 cu. in. arrays for 100 Hz from 0° to 90° off vertical and azimuth 90° are provided in Table 2.3.

**Table 2.3 Transmission Losses (TL) at Source in Peak Amplitude, RMS and Sound Exposure Level at 90° Azimuth and 0-90° From Vertical**

Degree Off Vertical	TL (dB)	Sound Level		
		0-p	RMS	SEL
0	0	252	242	232
30	12	240	230	220
45	24-36	216-228	218-206	208-196
90	36-48	228-204	218-144	208-184
Notes: 0-p = zero-to-peak amplitude RMS = root mean square SEL = sound exposure level				

The following Tables 2.4 to 2.6 show the predicted sound levels at Project Area water depths (40 to 350 m) at distances from a typical array. The values are based crossline levels at 30°, 45° and 90° off vertical of a source of 252 db re 1 µPa (RMS) with the array towed at 6 m depth.

**Table 2.4 Predicted Sound Levels (RMS dB), 30° From Vertical Based On Spherical and Cylindrical Spreading Transmission Losses**

Distance (m) from Array	Project Area Depth(m)					
	40 m	100 m	150 m	200 m	300 m	350 m
1	240	240	240	240	240	240
2	234	234	234	234	234	234
4	228	228	228	228	228	228
8	222	222	222	222	222	222
16	216	216	216	216	216	216
32	210	210	210	210	210	210
64	207	204	204	204	204	204
128	204	201	198	198	198	198
256	201	198	195	195	195	192
512	198	195	192	192	192	189
1024	195	192	189	189	189	186
2048	192	189	186	186	186	183
4096	189	186	183	183	183	180
8192	186	183	180	180	180	177

**Table 2.5 Predicted Sound Levels (RMS dB), 45° Off Vertical Based On Spherical And Cylindrical Spreading Transmission Losses**

Distance (m) from Array	Project Area Depth (m)					
	40 m	100 m	150 m	200 m	300 m	350 m
1	216	216	216	216	216	216
2	210	210	210	210	210	210
4	204	204	204	204	204	204
8	198	191	191	191	191	191
16	192	185	185	185	185	185
32	186	179	182	182	182	182
64	183	173	176	176	176	176
128	180	170	170	170	170	170
256	177	167	167	167	164	164
512	174	164	164	164	161	161
1024	171	161	161	161	158	158
2048	168	158	158	158	155	155
4096	165	155	155	155	152	152
8192	162	152	152	152	149	149



**Table 2.6 Predicted Sound Levels (RMS dB), 90° Off Vertical Based On Spherical And Cylindrical Spreading Transmission Losses**

Distance (m) from Array	Project Area Depth (m)					
	40 m	100 m	150 m	200 m	300 m	350 m
1	204	204	204	204	204	204
2	198	198	198	198	198	198
4	192	192	192	192	192	192
8	186	191	191	191	191	191
16	180	185	185	185	185	185
32	174	179	182	182	182	182
64	171	173	176	176	176	176
128	168	170	170	170	170	170
256	165	167	167	167	164	164
512	162	164	164	164	161	161
1024	159	161	161	161	158	158
2048	156	158	158	158	155	155
4096	153	155	155	155	152	152
8192	150	152	152	152	149	149
16384	147	149	149	149	146	146
32768	144	146	146	146	143	143

#### **2.4.2 Air Emissions**

Emissions from ship engines and onboard equipment will comply with the Air Quality Management (*Newfoundland and Labrador Environmental Protection Act*) and the Ambient Air Quality Objectives (*Canadian Environmental Protection Act*).

#### **2.4.3 Liquid Emissions**

Ballast water is stored in dedicated ballast tanks to improve vessel stability. No oil will be present in these tanks or in any discharged ballast/preload water. If oil is suspected to be in the water, it will be tested and, if necessary, treated to ensure that oil concentrations in the discharge do not exceed 15 mg/L as required by the MARPOL 73/78 (International Convention for the Prevention of Pollution from Ships, 1973, and the Protocol of 1978 related thereto), International Maritime Organisation (IMO) and the Offshore Waste Treatment Guidelines (OWTG) (NEB *et al.* 2002). The OWTG were developed specifically for the treatment and control of waste generated by petroleum operations related to exploration and production on Canada's offshore areas.

Bilge water often contains oil and grease that originate in the engine room and machinery spaces. Before discharge, bilge water is treated in accordance with MARPOL 73/78, IMO and OWTG, using an oil/water separator. The extracted water is tested to ensure that the discharges contain no more than 15 mg/L of oil.

#### **2.4.4 Solid Waste**

All solid waste will be transferred to shore and disposed of at an approved on-shore-based facility. Any hazardous materials (*e.g.*, oily rags) will be handled separately in hazardous materials containers.

Sanitary and food wastes will be macerated to a particle size of 6 mm or less and then discharged as per the OWTG.

### **2.5 Potential Malfunctions And Accidental Events**

There will be limited amounts of marine fuel and lube oil on board that could potentially be spilled to the ocean. Small spill events of kerosene and mineral oil (*i.e.* floatation fluid) from streamers can result from tears in the streamers from rough weather-induced entanglement, debris damage and possibly shark bites.

There is some potential for floatation fluid to be lost from a non-solid-streamer if the streamer becomes damaged. It is NWest's preference to utilise a seismic vessel equipped with solid-streamer technology, as this type of streamer is not reliant on floatation fluid to achieve a neutral ballast state, risks of accidental spill or incident is minimised. Accidental spills will be reported to the C-NLOPB immediately.

Other accidental events could include damage or loss of seismic gear, entanglement of seismic gear with fishing gear, and vessel collisions. Best management practices will be used on the seismic vessel to avoid gear loss or damage. Gear will be retrieved from the water if wave heights reach or exceed unacceptable limits. In case of severe weather, the vessel may return to shore until conditions improve. A trained fisheries observer will be on board during the seismic program to liaise with fishers who may have gear deployed in the Project Activity Area, in order to ensure effective and ongoing communication and avoid unnecessary gear conflicts and possible vessel collisions. Entanglement of marine mammals in seismic gear is not likely since streamers have no tangle gear and marine mammals are expected to avoid the vessel during operations. The onboard fisheries observer will be trained to keep watch for marine mammals during the survey program.

## 2.6 Health & Safety

NWest will submit a Safety Plan to the C-NLOPB outlining the company's commitment and philosophy toward ensuring personnel's health and safety are first and foremost in all NWest operations.

### 3.0 ALTERNATIVES TO THE PROJECT & ALTERNATIVES FOR THE PROJECT

#### 3.1 Alternatives To The Project

Alternatives to the Project are defined as functionally different ways of achieving the same end (CEA Agency 1997). An alternative to the proposed 3-D/2-D seismic survey is the 'do-nothing' scenario, or null alternative.

The 3-D survey can cover relatively large geographical areas, but have a short-term duration at any given location. A 2-D survey is typically used for exploring a large area to identify potential prospects which require further study. The 3-D seismic survey enables a greater resolution of potential existing oil and gas reservoirs. These surveys provide a detailed picture of the area under investigation allowing for a more detailed analysis of the potential quantity and distribution of hydrocarbons. Results of 3-D surveys are then used to find potential locations for exploration drilling. With regard to location, the proposed lines were selected based on a current understanding of the geological conditions.

#### 3.2 Alternative Means For The Project

Alternative means for the Project are defined as methods of similar technical character or methods that are functionally the same (CEA Agency 1997). Alternative means for carrying out this Project include variations in technology, Project schedule and location.

The proposed program covering Seismic Survey Option 2.1 is scheduled to commence August 1 2008 and conclude up to 75 days later (depending on seismic vessel procured). Future seismic surveys or geophysical programs after 2008 could occur anytime in the Spring to Fall months. Specific timing of the program within this period depends on a variety of factors, including vessel availability, weather conditions, timing and sensitivities associated with biological, fishing and socio-economic constraints. For example, mitigative options to minimise impacts include modification of the operations schedule within specific areas (*e.g.*, scheduling of specific lines so as to minimise fisher interactions).

With respect to the technology proposed, air source arrays are the most common, environmentally responsible and practical energy sources for marine geophysical surveys (Richardson *et al.* 1995). Noise pulses with high peak levels are produced; however, each pulse is short, limiting total energy. Richardson *et al.* (1995) also indicated that pulses from air source arrays generally decrease in intensity, but increase

in duration further away from the site. Sleeve exploders and gas guns have similar effects to air sources. Although marine vibrators produce lower instantaneous pressure than air sources, the total acoustic energy transmitted is similar due to the extended duration of the signal. Marine vibrators are also in their development infancy and are not a practical alternative. Marine vibrators cannot substitute for the air source array in seismic surveys as they provide a lower output at low frequencies.

There are few alternatives for the proposed survey methodology that would provide the information required to assess the area's submarine hydrocarbon resources. Exploration and production companies would not accept alternatives for their purposes. Airborne electromagnetic and magnetic (aeromag) surveys are valuable tools, but do not provide the level of detail required for precise resource assessments.

The compressed air array proposed for the current survey uses a proven technology and program design that is standard throughout many parts of the world. It has been used successfully on many occasions over the past several years on the Scotian Shelf, the west coast of Newfoundland, the Gulf of St. Lawrence, the Grand Banks and the Labrador Shelf and Slope, including the proposed survey area. Because of its reliability for data acquisition, the history of use in similar areas, and the available information related to its minimal environmental impacts, the compressed air technology proposed by NWest is the preferred alternative.

## 4.0 ENVIRONMENTAL ASSESSMENT METHODOLOGY

### 4.1 Overview and Approach

The environmental assessment methodology for the Project has been developed to satisfy regulatory requirements of the CEAA. The methodology used in this report has evolved from methods proposed by Beanlands and Duinker (1983), who stressed the importance of focusing the assessment on environmental components of greatest concern to potentially affected parties. In general, the methodology is designed to produce an environmental assessment document that:

- is focused on issues of greatest concern;
- addresses regulatory requirements;
- addresses issues raised by the public and other stakeholders;
- integrates engineering design and mitigative and monitoring programs into a comprehensive environmental management planning process; and
- integrates cumulative effects assessment into the overall assessment of residual environmental effects.

### 4.2 Scope of the Assessment

A focused environmental assessment requires a process of scoping to define the components and activities that are to be considered in the assessment, to identify the key environmental issues, and to set the spatial and temporal boundaries of the assessment. While the Project activities are generally focused within the footprint of the Project activities (*i.e.*, area of influence), the effects of these activities may extend beyond these footprints. The following section provides an overview of the scoping exercise conducted as part of this environmental assessment.

A number of studies have already been performed in the areas which will be key references to the environmental assessment (EA) NWest will have performed. These are:

- Western Newfoundland and Labrador Offshore Area Strategic Environmental Assessment (2005) and;
- Seismic Exploration Program Environmental Assessment for Exploration Lease 1069 (2005).
- Port au Port Seismic Program Screening and Registration (2006)

The Western Newfoundland and Labrador SEA Report (LGL Limited *et al.* 2005) concluded that petroleum exploration activity generally can proceed in the Western Newfoundland and Labrador Offshore Area with the application of standard mitigation measures currently applied to offshore exploratory activities elsewhere in the Newfoundland and Labrador offshore. The findings of this SEA Report identified areas potentially impacted by the planned geophysical surveys proposed by NWest.

The scope of the NWest proposed 3-D Program and geophysical surveys includes all of the components and activities described in Section 2 of this report, including any potential accidental events and malfunctions that may occur in relation to the Project.

#### **4.3 Issues Scoping and Valued Environmental Components**

The potential environmental effects were evaluated by identifying potential interactions between project and the local environment (ecological, societal and cultural and economic) through an issues scoping process. The C-NLOPB developed, in consultation with expert and advisory agencies the CEAA Scoping Document issued to NWest October 11, 2007. The document provides scoping of the Project, factors to be considered, scope of the factors to be considered, and the valued environmental components (VEC). The issues scoping process for this Project has included:

- Regulatory consultation (as described above);
- Review of available information on the existing biophysical and socio-economic environment in which the Project will occur;
- Review of relevant regulations and guidelines related to the Project;
- Review of other environmental reports in the vicinity (as listed above); and
- The professional judgment and experience of the study team.

##### **4.3.1 Stakeholder Consultation**

NWest Energy Inc. recognises the importance of communications to keep stakeholders informed about its proposed program and to obtain valuable input that may serve to contribute to the Project's overall success. A focused environmental assessment requires a process of scoping to define the components and activities that are to be considered in the assessment, to identify the key environmental issues, and to set the spatial and temporal boundaries of the assessment. Consultations have been undertaken with a variety of stakeholder groups to communicate Project information and determine

potential stakeholder issues of concern. Table 4.1 summarises consultations undertaken to date for the Project with fisher groups, non-government organizations, and with DFO.

**Table 4.1 List of Stakeholders Contacted**

Contact	Organisation	Issues/Concern
Jamie Coady	FFAW	Advised on schedule, sensitive fish periods and gear conflicts and further consultations with local community members.
Maureen Murphy	One Ocean	As above
Don Ivany	Atlantic Salmon Association	No comment
	CWS	Provided map of migratory bird colony for inclusion into EA document.
	Environment Canada	EA must assess spill events. All spills and leaks to be reported
Sheldon Peddle	Atlantic Coast Action Plan	No comment
	Transport Canada	Notice for Mariners to avoid conflict with commercial traffic
Bill Brodie	DFO- St. John's	Advised on data for RV surveys
Denis Bernier	DFO - Mont Joli	Provided RV survey data
Jim Meade	DFO - St. John's	Ensure Project does not conflict with recovery plans for species at risk
Alain Fréchet	DFO - Mont Joli	Provided update dated on cod migration
W. Goosney	NL Department of Fisheries & Aquaculture	No new fisheries. Aquaculture facility status quo.

Several general issues related to the petroleum industry as a whole were raised by the stakeholders, which revolved around the fishing industry in general. The Fish, Food and Allied Workers Union (FFAW) and One Oceans were provided the project description and maps of fishing effort from 2004 to 2007 over the Project Area from May to December. Through discussions among harvesters, the FFAW feel that consultations on NWest seismic program would not be effective or necessary at this time (Fall 2007). The FFAW and One Ocean has advised that seismic programs should be executed in the Fall season. Harvesters on the West Coast have insisted on this for all other operators and proponents.

Harvesters are concerned about this type of program at such critical times in the fishing season-both for gear conflicts and sensitive stages for a variety of species. Harvesters are easily engaged in the consultation process in this area, but we must make sure it is valid and necessary, to keep them interested. Although there has been limited fishing activity in the month of August, harvesters have concerns about biological, migration, feeding and spawning of various species. Through FFAW member discussions and



assessment of the potential seismic program for August 2008, the harvesters are willing to compromise on the timing of the first 3-D program.

These consultations should be executed at a time when the program approaches commencement (*i.e.* mid-late Summer). This way, proponents will have firm dates in their plans. As well, the harvesters will have current information on fishing effort and can advise on the current cyclical stages of all fisheries for the current season.

Based on the results of the issues scoping, the following seven VECs are considered in this environmental assessment document and Table 4.2 provides the rationale for their inclusion:

- marine and migratory birds;
- marine fish and shellfish
- marine mammals
- marine turtles
- species at risk
- sensitive areas; and
- commercial fisheries.

**Table 4.2 Selection of Valued Environmental Components**

<b>Environmental Component</b>	<b>Rationale</b>
Marine and Migratory Birds	The potential for effects from noise, presence of the seismic vessel related to attraction to lights and resultant stranding, and potential spills from accidental events ( <i>i.e.</i> streamer failure)
Marine Fish and Shellfish	The potential for effects from noise on critical life stages, and indirect effects on commercial fisheries
Marine Mammals	The potential for effects to distribution or displacement due to noise; collision with vessel and gear
Marine Turtles	The potential for effects to distribution or displacement due to noise; collision with vessel and gear
Species at Risk	Listed bird, fish and marine mammals can seasonally occupy the Affected Area
Sensitive Areas	Three coastal sensitive areas: Gros Morne National Park, and two lobster nursery areas.
Other Users	The potential for space conflict with other marine traffic.
Commercial Fisheries	The potential for effects on space conflict with vessels, interference with catchability, and gear damage.

## **4.4 Boundaries**

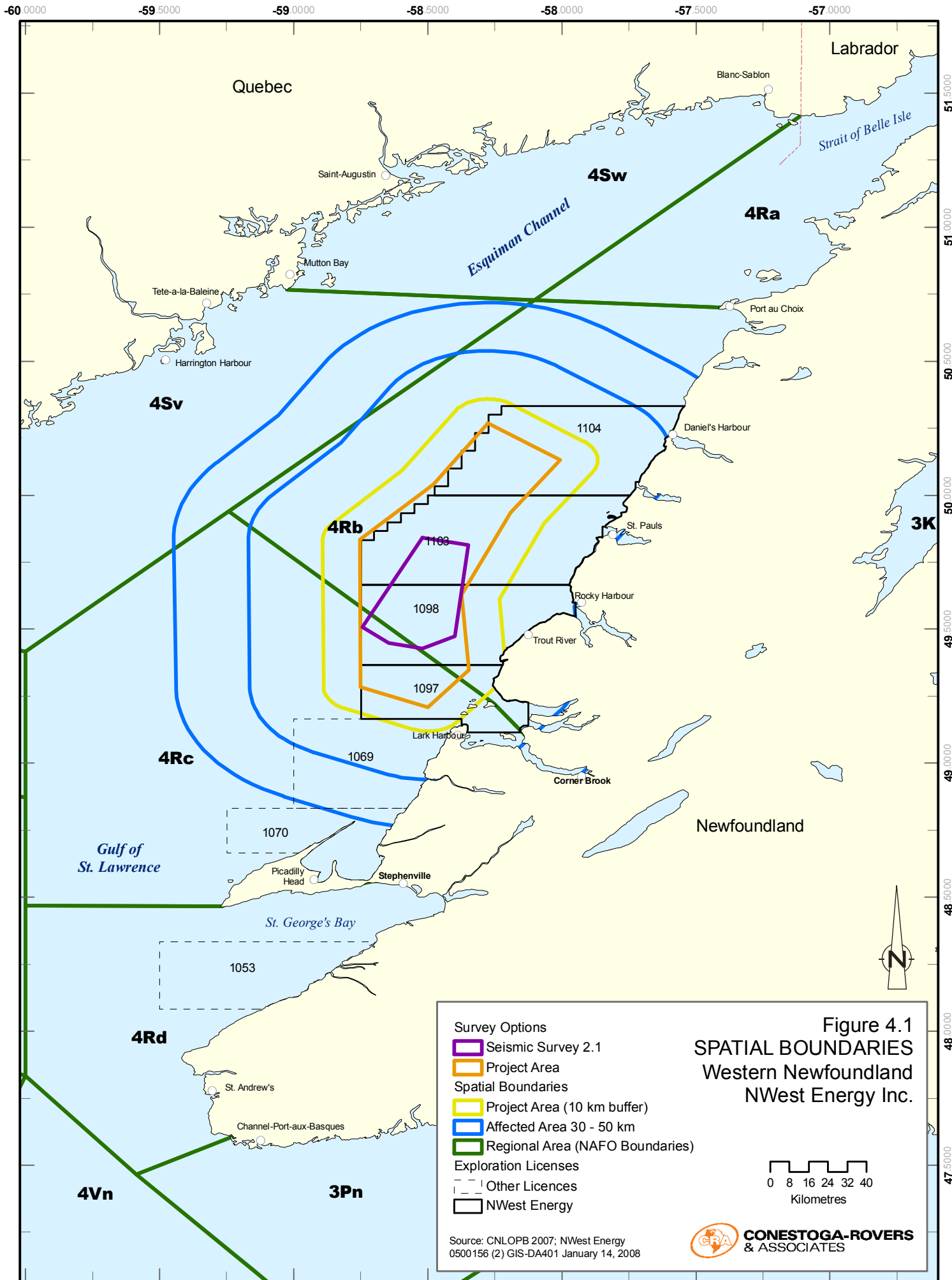
Boundaries provide a meaningful and manageable focus for an environmental assessment. They also aid in determining the most effective use of available study resources. Boundaries are described generally below, and in further detail as part of the effects analysis sections for each of the VECs.

### **4.4.1 Spatial Boundaries**

Spatial boundaries encompass those periods during, and areas within which, the VECs are likely to interact with, or be influenced by, the Project. Spatial boundaries for the assessment vary according to the VEC. Spatial ecological boundaries may be limited to the immediate Project Activity Area, or may extend well beyond the immediate footprints, as the distribution and/or movement of an environmental component can be local, regional, national or international in extent. Such factors as population characteristics and migration patterns are important considerations in determining ecological boundaries, and may influence the extent and distribution of an environmental effect. Such boundaries are particularly important for assessing cumulative environmental effects.

The assessment considers three levels of spatial boundaries: the Project Area, the Affected Area and the Regional Area (Figure 4.1).

The Project Area encompasses the physical space that the surveys are undertaken including a 10 km buffer to accommodate vessel turning with cables and streamers deployed. The line will be shot in a northeast and southwest direction.



**Figure 4.1**  
**SPATIAL BOUNDARIES**  
 Western Newfoundland  
 NWest Energy Inc.

- Survey Options**
- ▭ Seismic Survey 2.1
  - ▭ Project Area
- Spatial Boundaries**
- ▭ Project Area (10 km buffer)
  - ▭ Affected Area 30 - 50 km
  - ▭ Regional Area (NAFO Boundaries)
- Exploration Licences**
- Other Licences
  - NWest Energy

Source: CNLOPB 2007; NWest Energy  
 0500156 (2) GIS-DA401 January 14, 2008



The Affected Area is the area which could potentially be affected by project activities beyond the Project Area. This area will vary with species distribution, with the Project component (vessel presence) and the type of effect (*e.g.*, acute vs. behavioural). The most extensive area is that created by acoustic emissions for the vessel and air source. The extent of effects relies upon the research and field observations undertaken into effects by different species. These zones of influence are discussed for each biophysical VEC.

The Regional Area extends beyond the Affected Area boundary and is defined by the Northwest Atlantic Organisation (NAFO) Unit Areas 4Rb and 4Rc (Figure 4.1). Bathymetry is varied in the survey area, range from 40 to 350 m as the survey area is located on the shelf and slope. Sound attenuation varies with depth and oceanographic process (salinity/temperature features) and the potential for sound channel to propagate sound transmission.

#### **4.4.2 Temporal Boundaries**

The temporal boundary of this Project environmental impact assessment (EIA) is eight years, *i.e.*, it assesses potential impact that could result from the Project occurring between 2008 and 2015. This EIA Report assesses potential effects of geophysical operations from May to December. The 3-D surveys will take between 20 and 30 days or up to 75 days, depending on vessel and streamers, to complete. Beyond the first survey scheduled for August 2008, subsequent surveys will be determined annually in consultation with stakeholders.

Within that eight year period, exploration drilling may occur, of course being subject to approval under CEAA. Geophysical programs in that phase include well site surveys and VSPs. Well site surveys can take up to one week to complete. A VSP can be concluded in one day.

Temporal ecological boundaries consider the relevant characteristics of environmental components or populations, including the natural variation of a population or ecological component, response and recovery times to effects, and any sensitive or critical periods of a VEC's life cycle (*e.g.*, spawning, migration), where applicable.

#### **4.4.3 Technical Boundaries**

Technical boundaries represent any technical limitations on the ability to assess, evaluate, and/or monitor potential environmental effects. For example, insufficient data

on the abundance, status, and distribution of a fish or wildlife population may limit the ability to predict the potential effects of a proposed development on it. Where such limitations exist, it is important that they be recognized and acknowledged.

**4.5 Potential Interactions, Issues and Concerns**

As a first step in the effect analysis, potential issues and concerns are identified, based on the interactions identified in the potential interaction matrix (Table 4.3).

**Table 4.3 Potential Project-Environment Interaction Matrix**

Valued Environmental Component	Marine and Migratory Birds	Marine Fish and Shellfish	Marine Mammals	Marine Turtles	Species at Risk	Sensitive Areas	Commercial Fisheries	Marine Traffic
3-D Seismic Surveys - Noise Emissions (Acoustic Array)	X	X	X	X	X		X	
Well Site Survey - Noise Emissions (Acoustic Array)		X	X	X	X		X	
Vertical Seismic Profile - Noise Emissions (Acoustic Array)		X	X	X	X		X	
Vessel Presence	X		X	X	X		X	X
Presence of Streamers and Cables			X	X	X			
Vessel Liquid Emissions	X	X			X			
Accidental Spills	X	X	X	X	X	X	X	

**4.6 Description of Existing Conditions**

Existing conditions (*i.e.*, pre-Project) are described for each VEC. The description is restricted to a discussion of the status and characteristics of the VEC within the boundaries established for the assessment and focuses on aspects that are relevant to potential Project interactions.

#### 4.7 Significance Criteria and Evaluation

The significance of the predicted environmental effects of the Project is evaluated based on a set of environmental effects evaluation criteria and significance definitions developed for each VEC.

#### 4.8 Impact Analysis and Mitigation

For each VEC, the potential interactions are investigated and evaluated based on current scientific knowledge with regard to each interaction. Effects are analyzed qualitatively, and, where possible, quantitatively, using existing knowledge, professional judgment, and appropriate analytical tools.

Where applicable, mitigation measures are identified and the significance of the predicted environmental effects of the Project are evaluated based on a set of environmental effects evaluation criteria and significance definitions developed for each VEC, including magnitude, geographic extent, frequency of occurrence, duration and reversibility. Significant environmental effects are those adverse effects that will cause a change in the VEC that will alter its status or integrity beyond an acceptable level. Environmental effects are evaluated as either significant or not significant, based on significance definitions. The significance evaluation of residual effects for each VEC was based on the criteria as specified by the Canadian Environmental Assessment Agency (1994, 1997):

- **Magnitude** – the nature and degree of the predicted environmental effect. Rating depends on the nature of the VEC and the potential effect. For biophysical VECs the rating system is as follows:

<i>Negligible</i>	Essentially no effect
<i>Low</i>	Affects a specific group or critical habitat for one generation or less; within natural variation;
<i>Medium</i>	Affects a portion of a population or critical habitat for one or two generations; temporarily outside the range of natural variability;
<i>High</i>	Affects a whole stock, population or critical habitat (may be due to the loss of an individual(s) in the case of a species at risk) outside the range of natural variability.

- For socio-economic components, the magnitudes of potential effect are defined as:

*Low* Does not have a measurable effect on fishing or catch levels or marine traffic;

*Medium* Has a measurable effect on with marine traffic and other offshore operators or on fishing or catch levels, but is within natural variability;

*High* Has a measurable and sustained adverse effect on marine traffic and offshore operations or fishing activities or catch levels beyond natural variability.

- **Geographic extent** - the area over which the particular effect will occur.

Immediate Effects are adjacent to the array or vessel, within 10s of metres

Local Within 1-10 km

Regional Within 30-50 km

- **Frequency** - how often the effect will occur.

Isolated occurring once or twice

Intermittent occurring repetitively with starts and stops

Continuous occurring non-stop

- **Duration** - how long the disturbance will occur.

Immediate limited to days

Short-term limited to two weeks to one month,

Long term six months to one year

- **Reversibility** - the ability of a VEC to return to an equal, or improved, condition once the disturbance has ended (for example, reclaiming habitat area equal or superior to that lost). Predicted effects are rated as reversible or irreversible, based on previous research and experience.

- **Uncertainty** - This allows for disclosure of the level of scientific confidence in the predicted outcomes, and the general reliability of the data and models used to predict impacts.

#### **4.9 Follow-Up and Monitoring**

Follow-up and environmental effects monitoring (EEM) programs provide essential feedback, in particular with respect to:

- Predicted project effects;
- Unanticipated effects;
- The necessity and efficacy of project management strategies; and
- Cumulative effects.

Monitoring and follow-up requirements are evaluated for each VEC and are linked to the sensitivity of a VEC to both Project-related and cumulative environmental effects. The likelihood and importance of such effects, as well as the level of confidence associated with the adverse residual effects rating, are also taken into consideration.

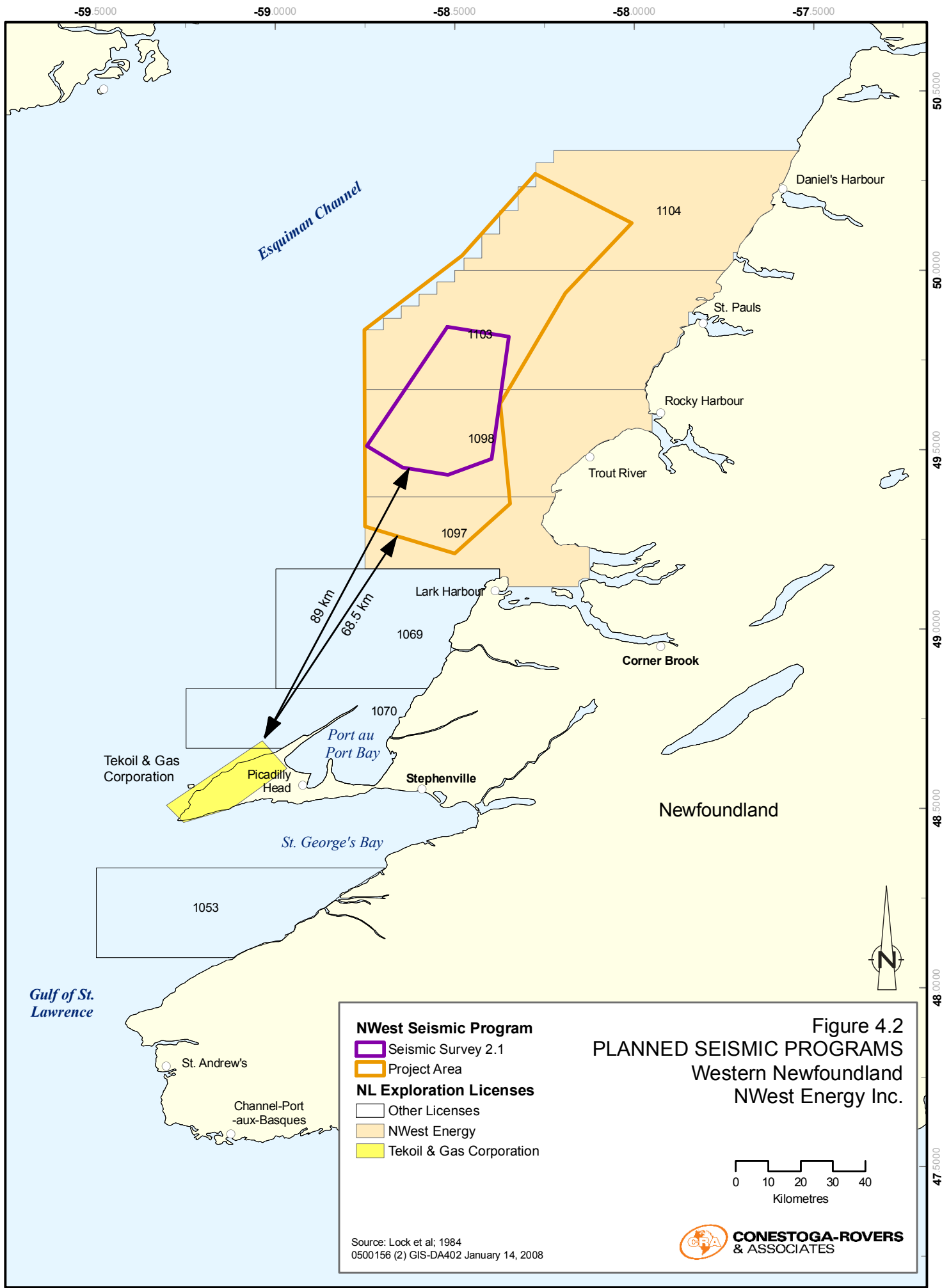
Monitoring by the proponent may be undertaken for a number of reasons including regulatory or corporate compliance (environmental compliance monitoring or ECM), evaluation of mitigating measures, strengthening predictive capacity in future EAs, and commitments to third parties.

#### **4.10 Cumulative Effects**

An assessment pursuant to *CEAA* must address potential cumulative effects. The discussion of cumulative effects for this assessment is integrated into the assessment of environmental effects for each VEC such that the overall assessment of residual environmental effects includes the consideration of cumulative effects.

The C-NLOPB is responsible for approving applications for the petroleum industry and is the source for other oil and gas activities in the Region. There are two potential seismic exploration projects in the Port au Port area (Figure 4.2). The location of these two surveys are in the same location and are 68.5 km south of the most southern boundary of the Project Area and 143 km from Seismic Survey Area Option 2.1. Tekoil and Gas Corp. is conducting seismic work over part of, and adjacent to, the Port au Port Peninsula (EL 1071) during a six-week period from October 2008 to April 2009. PDI Productions Inc. is commencing work in the fall of 2007 in the Port au Port area (EL 1070) but if the Project undergoes unavoidable delays, the seismic work could be undertaken anytime in the next three years. Exploration drilling is occurring on land (direction drilling) in that area.





-59.5000

-59.0000

-58.5000

-58.0000

-57.5000

50.5000

50.0000

49.5000

49.0000

48.5000

48.0000

47.5000

Esquimaun Channel

Daniel's Harbour

1104

St. Pauls

Rocky Harbour

Trout River

1097

Lark Harbour

1069

Corner Brook

1070

Port au Port Bay

Stephenville

Newfoundland

St. George's Bay

1053

Gulf of St. Lawrence

St. Andrew's

Channel-Port-aux-Basques

Tekoil & Gas Corporation

Picadilly Head

89 km

68.5 km

**NWest Seismic Program**

Seismic Survey 2.1

Project Area

**NL Exploration Licenses**

Other Licenses

NWest Energy

Tekoil & Gas Corporation

Figure 4.2  
**PLANNED SEISMIC PROGRAMS**  
 Western Newfoundland  
 NWest Energy Inc.



Source: Lock et al; 1984  
 0500156 (2) GIS-DA402 January 14, 2008



Past or present activities potentially affecting a VEC have been considered in the description of existing conditions as applicable for each VEC. Existing regulations, guidelines and conditions of approval apply to other regional activities, thereby also limiting the potential for cumulative effects. It is within this context that the potential for cumulative environmental effects resulting from these other projects and activities are evaluated for each of the relevant VECs.

## 5.0 ENVIRONMENTAL BASELINE

### 5.1 Marine Physical Setting

Information on physical attributes is partially derived from Western Newfoundland and Labrador Offshore Area Strategic Environmental Assessment (LGL Limited *et al.* 2005; p. 6-11).

#### 5.1.1 Seafloor Stratigraphy and Bathymetry

Stratigraphic units within the area of the exploration licenses were described by Josenhans and Zevenhuizen (GSC Open File 2700, 1993) based on a regional grid of high resolution seismic surveys complemented by piston cores and bottom samples conducted in 1989 and 1990. Figure 5.1 shows the surficial sediments.

Glacial tills and postglacial deposits with smaller areas of iceberg turbate and glaciomarine sediments predominantly characterize bottom stratigraphy within the Project Area.

The basal unit (Unit 1) in the area is described as a massive, unstratified deposit of glacial tills and ice contact sediments overlying bedrock. The deposit is variable in occurrence ranging in depth from a few metres of discontinuous material to multiple sequences of morainal deposits up to 180 metres in thickness. The unit consists of four stratigraphic positions of which the Middle and Upper Tills have been determined to be within the Project Area- the correlation of the Middle Till in the Esquiman Channel is discontinuous and uncertain (Josenhans and Zevenhuizen 1993). The distribution of these tills off Western Newfoundland suggests ice movement in a westerly direction.

Glaciomarine sediments (Units 2 and 3) are found (87 sq km) in the western portion of EL 1103. These lower sediments (Unit 2) are strongly laminated ice-proximal deposits are found to locally interfinger or underlie the glacial tills (ice tongue) and thicken to 15 metres in areas adjacent to ice marginal positions, however the unit typically is conformably draped over the underlying till surface. The upper sediments (Unit 3) are deposited in an ice distal environment filling depressions in the underlying surface and ponding in deep basins up to 15 metres thick.

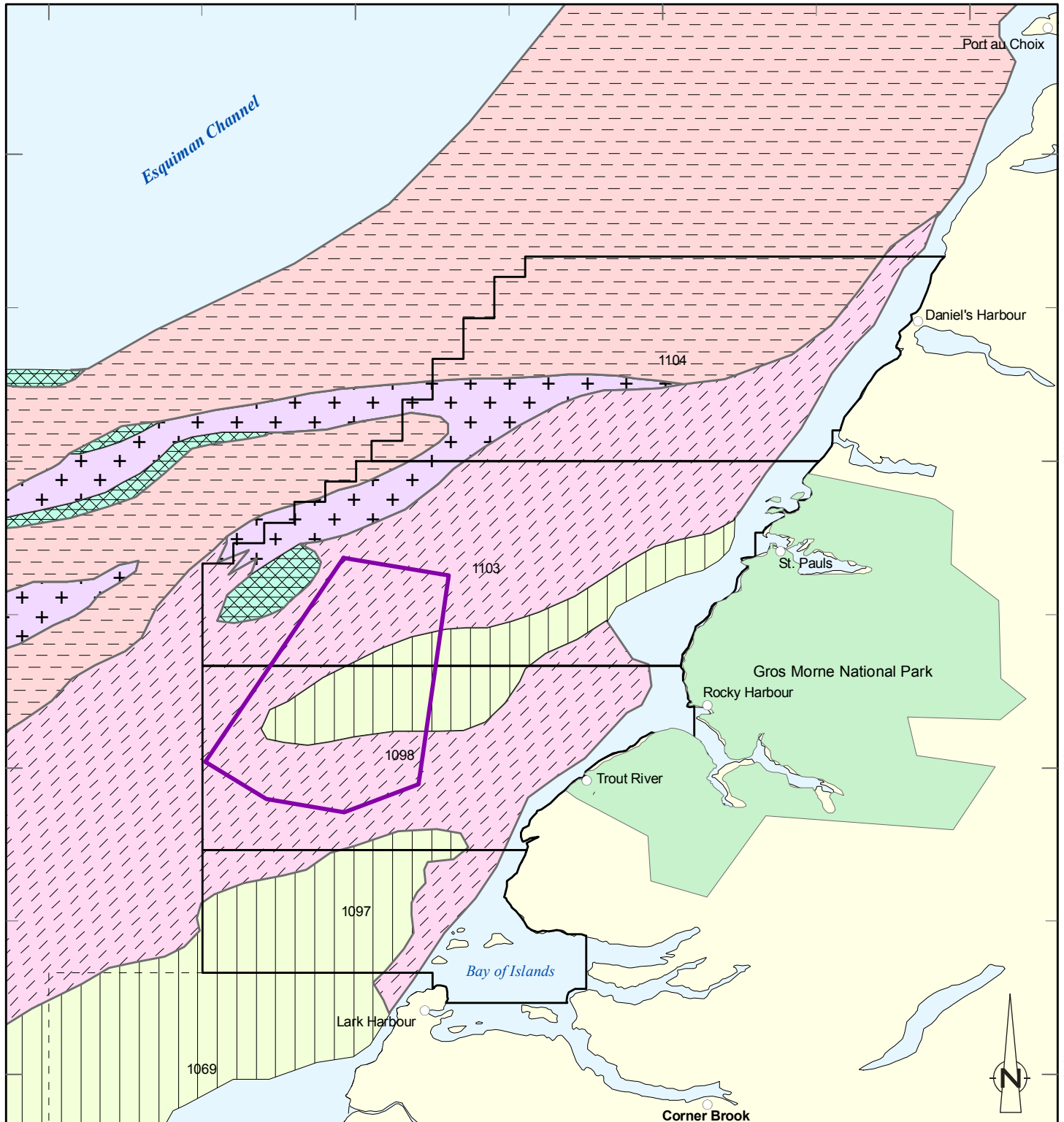
Iceberg turbates are unstratified deposits reworked by scouring of the glaciomarine sediments, and less frequently glacial tills, by grounded icebergs.

-59.0000

-58.5000

-58.0000

-57.5000



50.5000

50.0000

49.5000

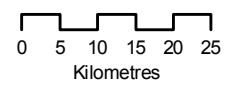
49.0000

48.5000

**Stratigraphic Units**

- Postglacial, basal, ponded muds
- Postglacial reworked sands / gravels
- Iceberg turbate
- Glaciomarine sediments
- Ice contact / till
- Discontinuous till over bedrock
- Bedrock
- Survey Option 2.1

Figure 5.1  
**QUATERNARY  
 SEDIMENTS**  
 Western Newfoundland  
 NWest Energy Inc.



Source: Geological Survey of Canada, Open File 2700, 1993  
 050016 (2) GIS-DA501 January 14, 2008



Postglacial deposits (Unit 5) are the most frequently occurring in the Gulf of St. Lawrence. The lower deposit (Unit 5a) consists of smooth surfaced ponded muds that are occasionally disturbed by pockmarks. This stratigraphic unit can range from 10 metres in some areas to 60 metres at the mouth of the St. Lawrence River. Postglacial transgression of sea level recovery has reworked the sands and gravels of pre-existing deposits in Unit 5b. Subsequent current action continues to sort and transport these sediments.

Water depths within the Project Area range from 40 m to 350 m. Approximately 75% of the Project Area is on continental shelf (<200 m) and the remainder is on slope (200 to 300 m depths). Detailed bathymetry is shown in Figure 5.2.

### **5.1.2 Subsurface Geology**

The Project Area lies in the Humber geological zone. Newfoundland's geology is dynamic, and constantly evolving, with no internal temporal and spatial reference point. Therefore, the geology of Newfoundland and its offshore areas should be viewed from the interior, relatively stable, primordial continental crust of North America. It is upon this basement that younger rocks were laid down, reworked, and structurally telescoped by sedimentary processes, tectonic forces, igneous activity, and metamorphism to form what is termed "the Humber zone". Three other crustal fragments were added to this zone by compressional tectonism, and later reshaped by sedimentary processes, igneous activity, and tensional forces to create the island of Newfoundland and its offshore areas as recognized today (Williams 1995a,b; Sandford 1993a,b). Early Cambrian to Middle Ordovician sedimentary rocks of the Humber Zone of western Newfoundland contain hydrocarbon sources and reservoir rocks.

For more detail on subsurface geology in the Project Area, refer to the Western Newfoundland and Labrador Offshore Area Strategic Environmental Assessment (Section 2.1.1 and Figure 2.1 - 2.4; LGL Limited *et al.* 2005, pp.6-9).

### **5.1.3 Hydrocarbon Potential**

The Paleozoic rocks of the Humber zone were the first in the Province to be recognized as having petroleum potential. In 1812, Mr. Parsons noticed oil floating on the surface of Parson's Pond on the Great Northern Peninsula. In subsequent years, numerous oil and gas seeps, bituminous residues, and oil shales were found in other areas. In 1867, Newfoundland's first oil well was drilled, and during the next 98 years up to sixty shallow wells were advanced in four areas (Parson's Pond, St. Paul's Inlet, Deer Lake

Basin, and at Shoal Point on the Port au Port Peninsula), more than half of which encountered hydrocarbons.

A new era of oil exploration began in 1995 in western Newfoundland when Hunt Oil and its partner PanCanadian drilled the first modern well that was based on new seismic mapping and geological theory. The well drilled in the Port-au-Port area, south of NWest blocks, indicate that hydrocarbons are high quality, sweet oil consistent with the Cambrian-Ordovician source rock.

The area to the west of the Appalachian Structural Front within the undeformed Lower Paleozoic East St. Lawrence Platform remains a relatively untested area with good hydrocarbon prospects (Sinclair 1990). For detailed description of hydrocarbon potential in the Project Area, refer to the Western Newfoundland and Labrador Offshore Area Strategic Environmental Assessment (Section 2.1.2) (LGL Limited *et al.* 2005; pp.11-14).

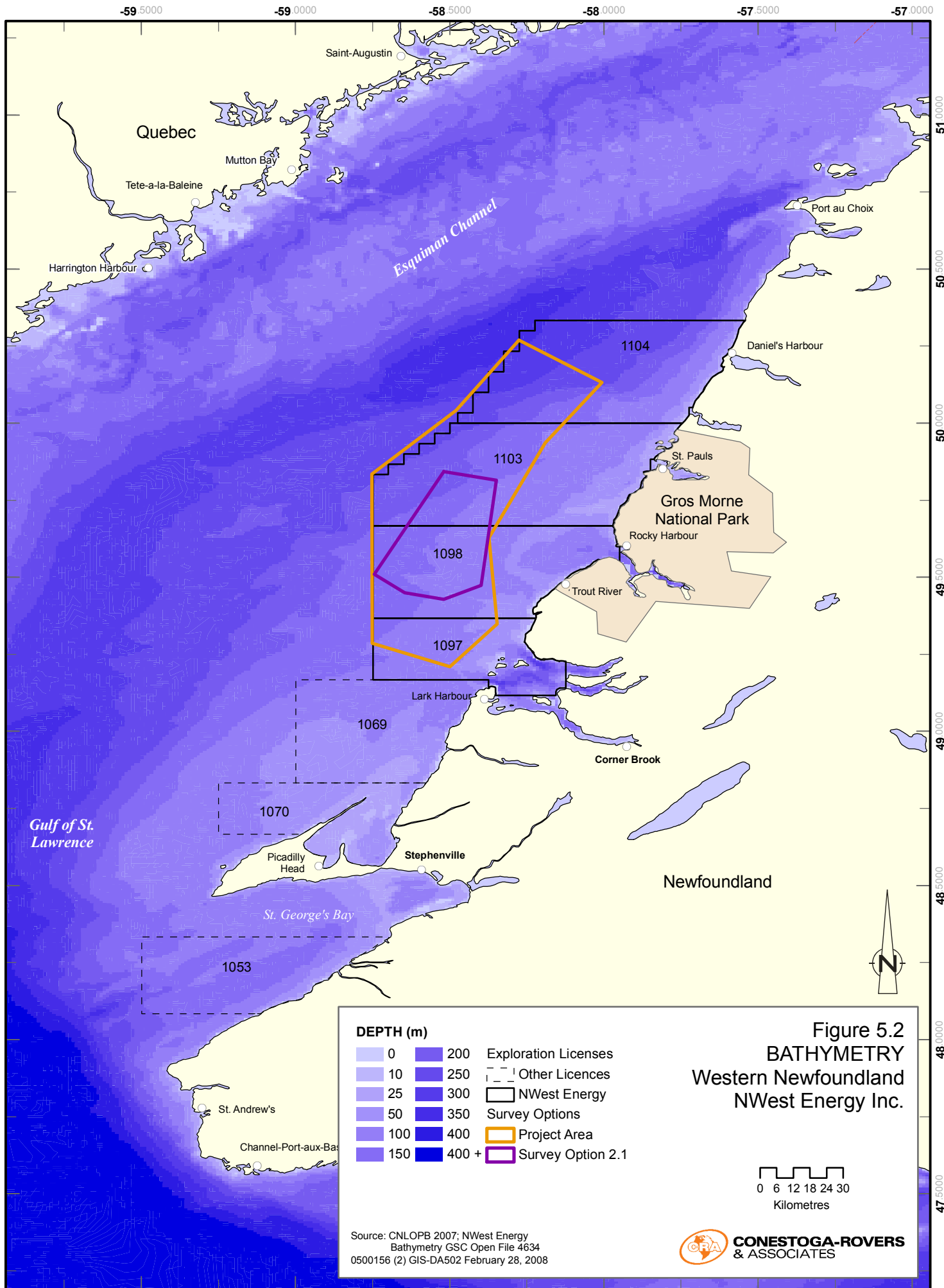
#### **5.1.4 Tectonics and Seismicity**

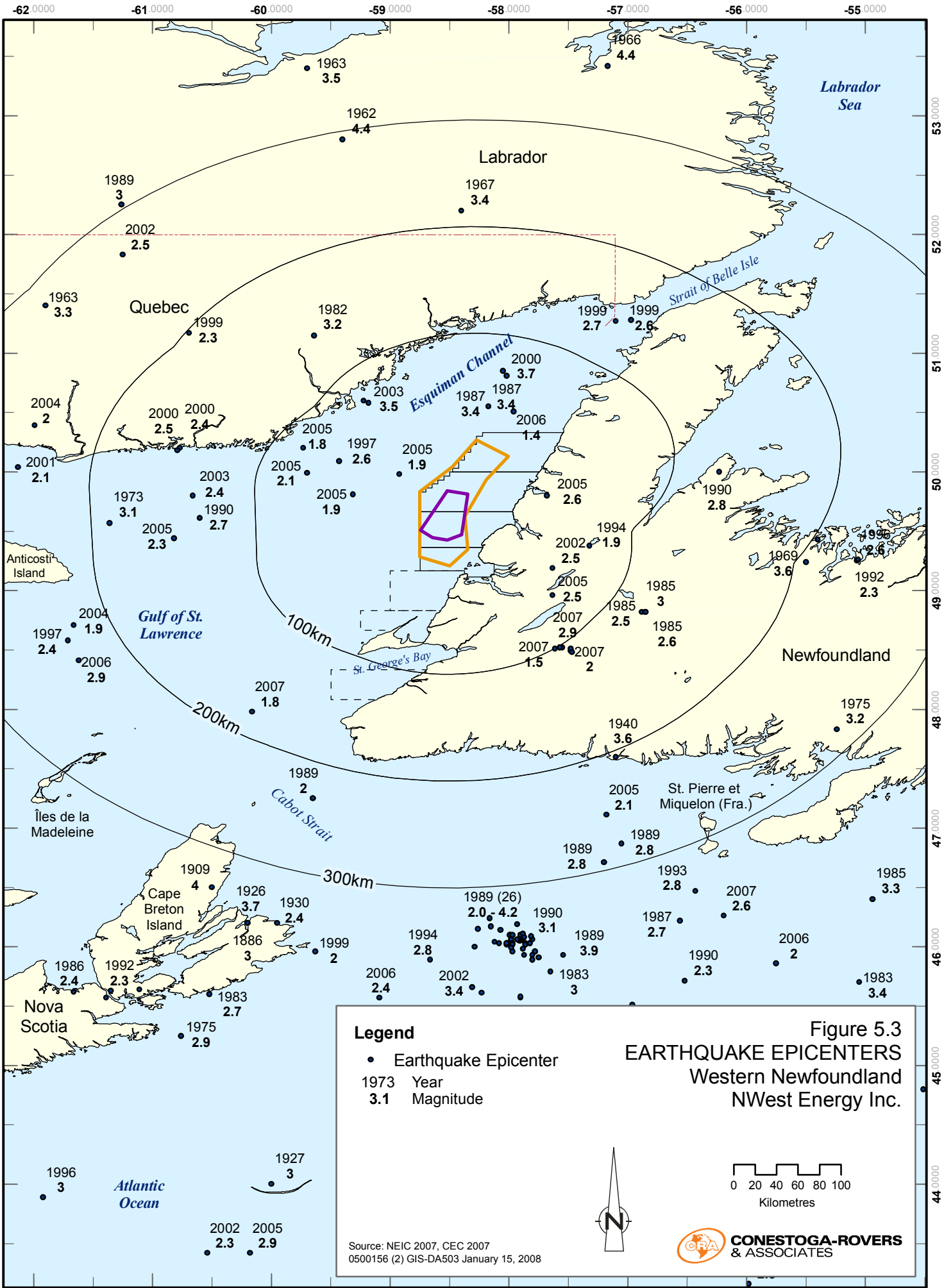
The potential for structural damage by an earthquake is primarily determined by two mechanisms: the nature of associated ground movements at the structure site, and the construction elements of the structure itself. In Canada, expected ground motions (also referred to as seismic hazard) are calculated on the basis of probability theory and are represented by seismic zoning maps (see Western Newfoundland and Labrador Offshore Area Strategic Environmental Assessment – Figures 2.9 and 2.10 (NRCan website 2005); LGL Limited *et al.* 2005; p.17).

Between 1973 and 2007, 37 seismic events within 200 km and 15 seismic events within 100 km of the Project Area are recorded by NRCan and the National Earthquake Information Centre (Figure 5.3). The magnitude ranged between 1.1 and 3.7 on the Richter scale. The Project Area falls within acceleration and velocity Zone 1, and is, therefore, considered to have a relatively low seismic hazard.

#### **5.1.5 Meteorology and Climate**

The climate zone of the Project Area is classified as West Coast: marine influence from Gulf of St. Lawrence normally reduces temperature extremes, but causes increased precipitation, especially during fall and early winter, when snowfalls are most frequent. Locally severe wind speeds descend from Long Range Mountains during favorable winter weather patterns (Newfoundland Labrador Heritage Project 1999).





-62.0000   -61.0000   -60.0000   -59.0000   -58.0000   -57.0000   -56.0000   -55.0000

53.0000  
52.0000  
51.0000  
50.0000  
49.0000  
48.0000  
47.0000  
46.0000  
45.0000  
44.0000

Labrador Sea

Labrador

Quebec

Esquimaux Channel

Strait of Belle Isle

Gulf of St. Lawrence

Newfoundland

Anticosti Island

Îles de la Madeleine

Cape Breton Island

Nova Scotia

Atlantic Ocean

100km

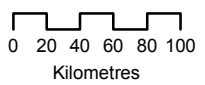
200km

300km

Cabot Strait

St. George's Bay

St. Pierre et Miquelon (Fra.)



CONESTOGA-ROVERS & ASSOCIATES



Three principal factors shape the region's climate:

- 1) The province is in a geographic zone characterised by marked seasonal differences in the amount of energy received from the sun, and by winds blowing predominantly from the west;
- 2) The position of Newfoundland with respect to the Canadian mainland, and the division of the province into island and mainland (Labrador) portions, leads to distinctive onshore and offshore local airflow features for the island and Labrador;
- 3) The extensive area of cold water and seasonal ice offshore, including the Labrador Current system, has a direct bearing upon climate and weather; and the distinctly warmer Gulf Stream/North Atlantic Drift system to the southeast of the Grand Banks affects the properties of air reaching the province from the south and east.

In addition, landform features such as prominent uplands, and mountain ranges, and sheltered valleys and lowlands, influence the finer details of climate and weather.

Winter, defined here as the season having long-term ("climatological") average daily temperatures below freezing (0°C), is about four months (December through March) over much of the island. The onset of spring is delayed by a prevalence of cool polar air masses and low sea surface temperature. Coastal areas exposed to the north and east endure repeated spells of low cloud, fog and light precipitation. In general, however, there is a significant reduction in both precipitation and the frequency of high winds during the period from May until July, more especially on the island. The retreat of the polar front jet stream to the north, combined with the shift in prevailing wind direction to southwest, causes a change in the temperature patterns by mid-late June. The highest daily maximum temperatures of summer (typically 27 to 31°C) normally occur well away from the south coast, which is now more vulnerable to sea fog. There is a marked cooling northward on the Northern Peninsula. In the fall over the entire province there is a marked increase in precipitation and strong wind frequencies during October and November.

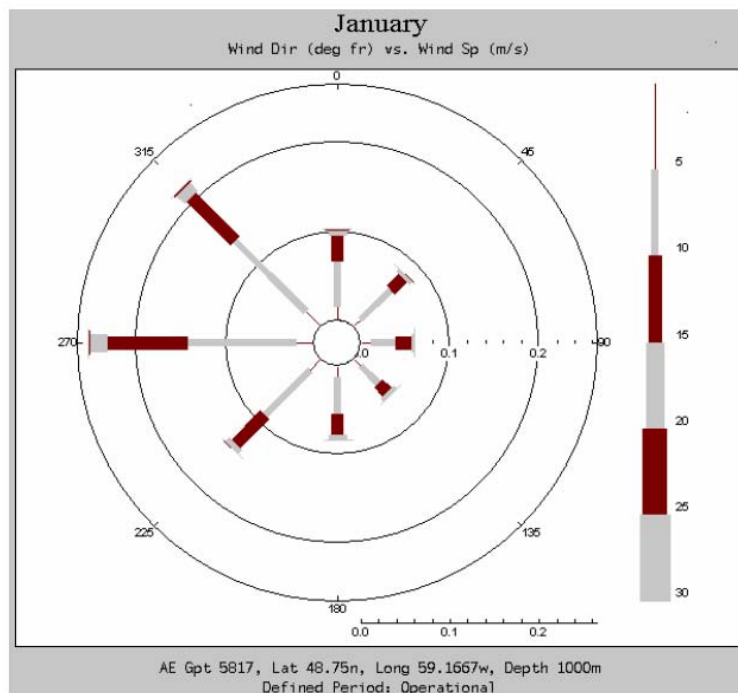
#### 5.1.5.1 Wind

This section is based on the AES-40 data set (Swail *et al.* 1999, Swail and Cox 2000) that contains 49 years (1954 to 2003) of climatology data for a number of points in the Gulf of St. Lawrence. Grid point 5817 (48.75°N; 59.17°W) was deemed to be close enough to the Project Area for the purposes of wind analysis. Winds are variable in direction by season as shown in Table 5.1.

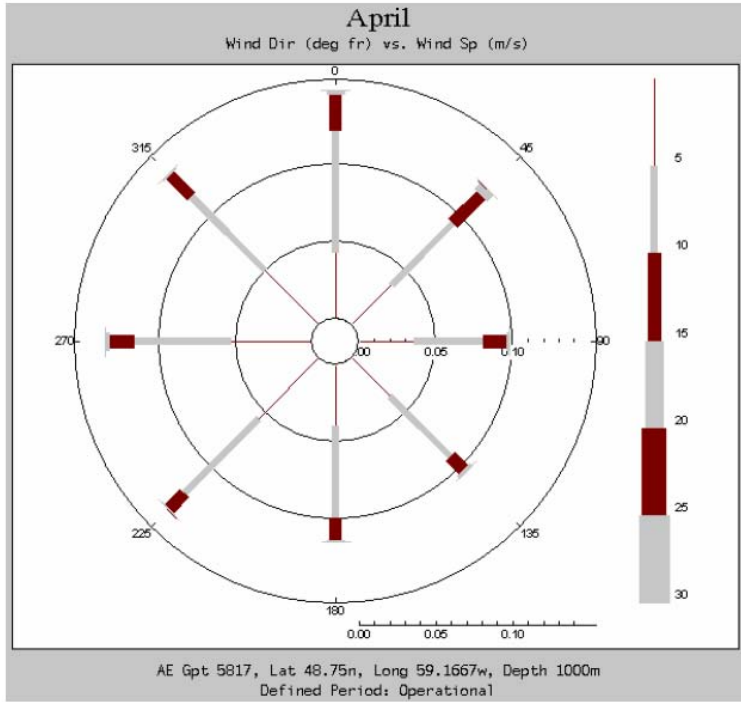
**Table 5.1 Wind Direction West Coast of Newfoundland**

Month	Dominant Wind Direction (From)
November to March	West to Northwest
April	Southwest to Northwest
May to August	South to Southwest
September to October	Southwest to West

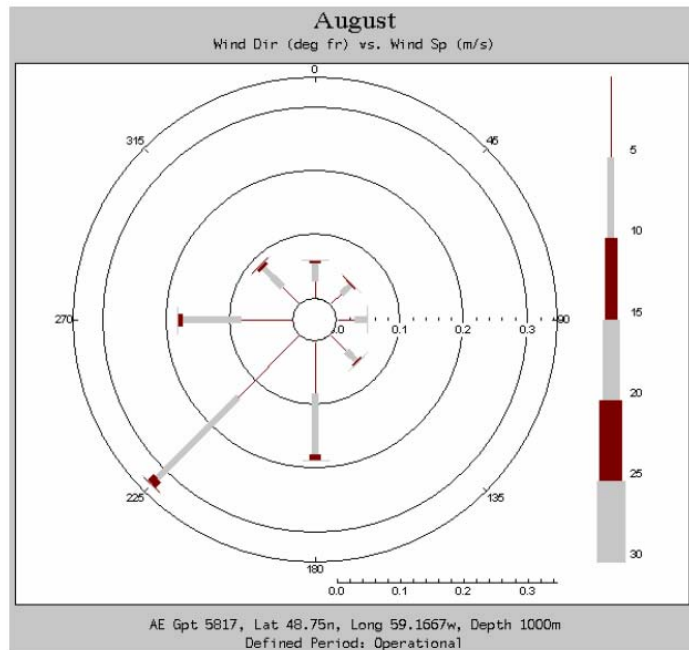
Detailed wind data are provided in Section 2.3.1 of the LGL Limited *et al.* (2005) SEA report (pgs 21 to 29) by wind speed, direction on a monthly basis. In summary, the highest winds, recorded at 25 m/s, occurred in December and January, although November to March winds ranged from 18 to 25 m/s. The lowest winds are in July (10 to 15 m/s). Gale force winds (17.2 to 24.2 m/s) occurred in all months except July and August. Seasonal wind roses for the grid point are provided in Figure 5.4 to 5.7. No hurricane force winds ( $\geq 32.7$  m/s) were recorded at the grid point over the 49 year period.



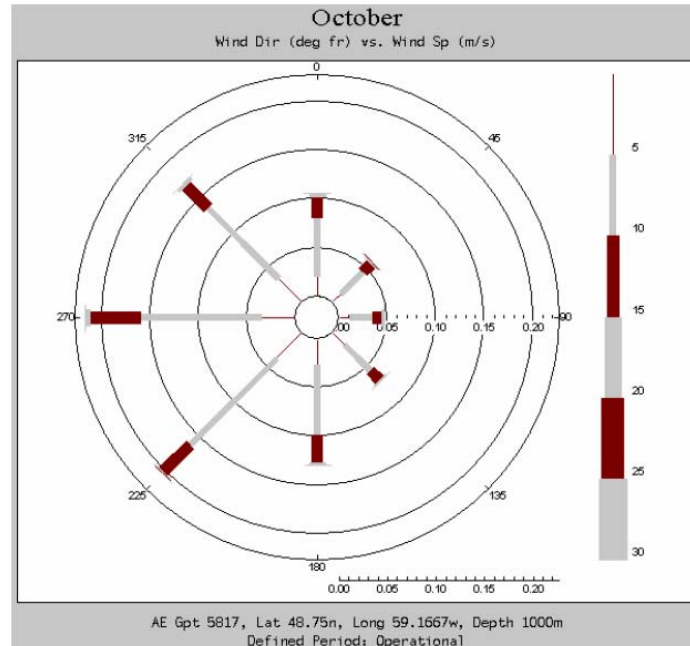
**Figure 5.4 January Wind Rose**



**Figure 5.5 April Wind Rose**



**Figure 5.6 August Wind Rose**



**Figure 5.7 October Wind Rose**

### **5.1.5.2 At Sea Air Temperature**

The steady northwestward decrease in average air temperature during the winter period is due not only to increasing latitude (and therefore less solar energy received at this time of year), but also to an increased frequency of colder Arctic air masses. As winter advances, sea ice formation and movement off the coasts of Labrador and northern parts of the island also help to lower temperatures.

The minimum air temperature recorded from a weather buoy anchored off the coast of Mont Louis (49° 33'N 65° 45'W) of -6.5°C occurs in February and the maximum mean temperature of 16 °C occurs in August.

### **5.1.5.3 Visibility and Fog**

Advection fog from warm moist air over cooler waters of the Gulf occurs in April and increases during May to July. Fog decreases in August as the sea temperatures increase and the sea /land differential is reduced. October has the lowest occurrence of reduced visibility (< one kilometre).

Good Shipping Weather is defined as the joint frequency of occurrence of visibility greater than 2.2 nautical miles and wind speed less than 25 kts. In general, good flying and shipping weather is most prevalent during December through June.

#### **5.1.5.4 Precipitation**

Climate Normals from 1971 to 2000 for Corner Brook have an annual total precipitation record of 1270.8 mm, of which 421.9 mm was snow and 848.9 mm was rain.

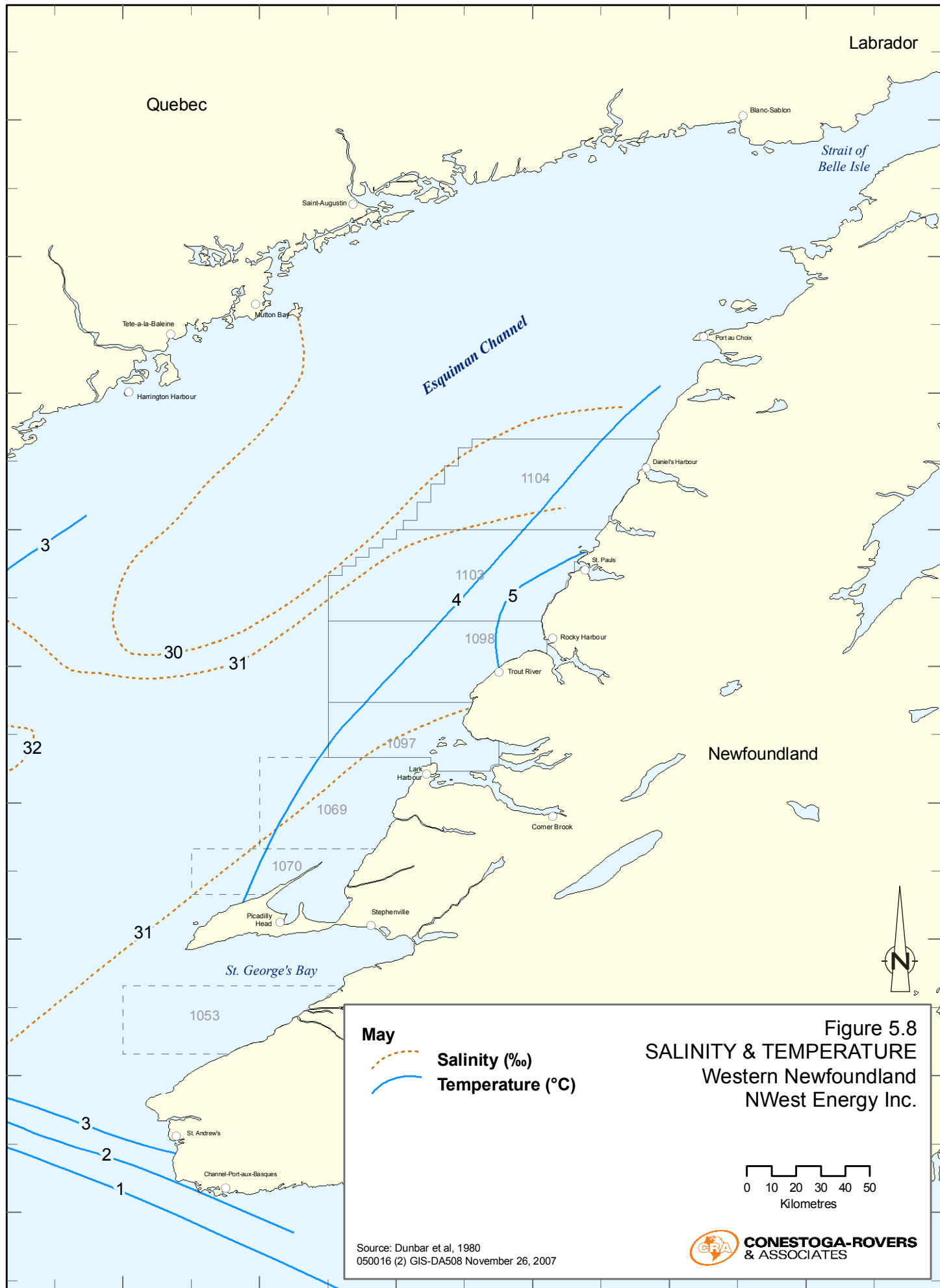
### **5.1.6 Chemical and Physical Oceanography Setting**

#### **5.1.6.1 Water Temperature and Salinity**

The mean annual temperature of the sea surface ranges from a minimum mean of -0.79 °C in February and -0.75 °C in March. In May, the surface temperatures are 3-5 °C (Figure 5.8) due to oceanic water entering through the Cabot Strait. The maximum means of 15.32 °C and 15.52 °C occur in August and September, respectively (Figure 5.9), kept cool under the influence of the Labrador Current.

As shown on the profiles, during the spring and summer, this temperature range decreases significantly with depth in the upper waters due to the presence of a cold intermediate layer between approximately 50 and 200 m. The cold water is due to the influx of Labrador Current water through the Strait of Belle Isle. Below 200 m, the temperature is in the range of 4 °C to 6 °C. In winter, the upper layer cools to below 0°C and becomes a nearly homogenous mixed layer (Figure 5.10). Figure 5.11 shows average temperature profiles in summer and winter in NAFO 4R.

-59.500000 -59.000000 -58.500000 -58.000000 -57.500000 -57.000000



**May**

Salinity (‰)  
Temperature (°C)

**Figure 5.8**  
**SALINITY & TEMPERATURE**  
Western Newfoundland  
NWest Energy Inc.

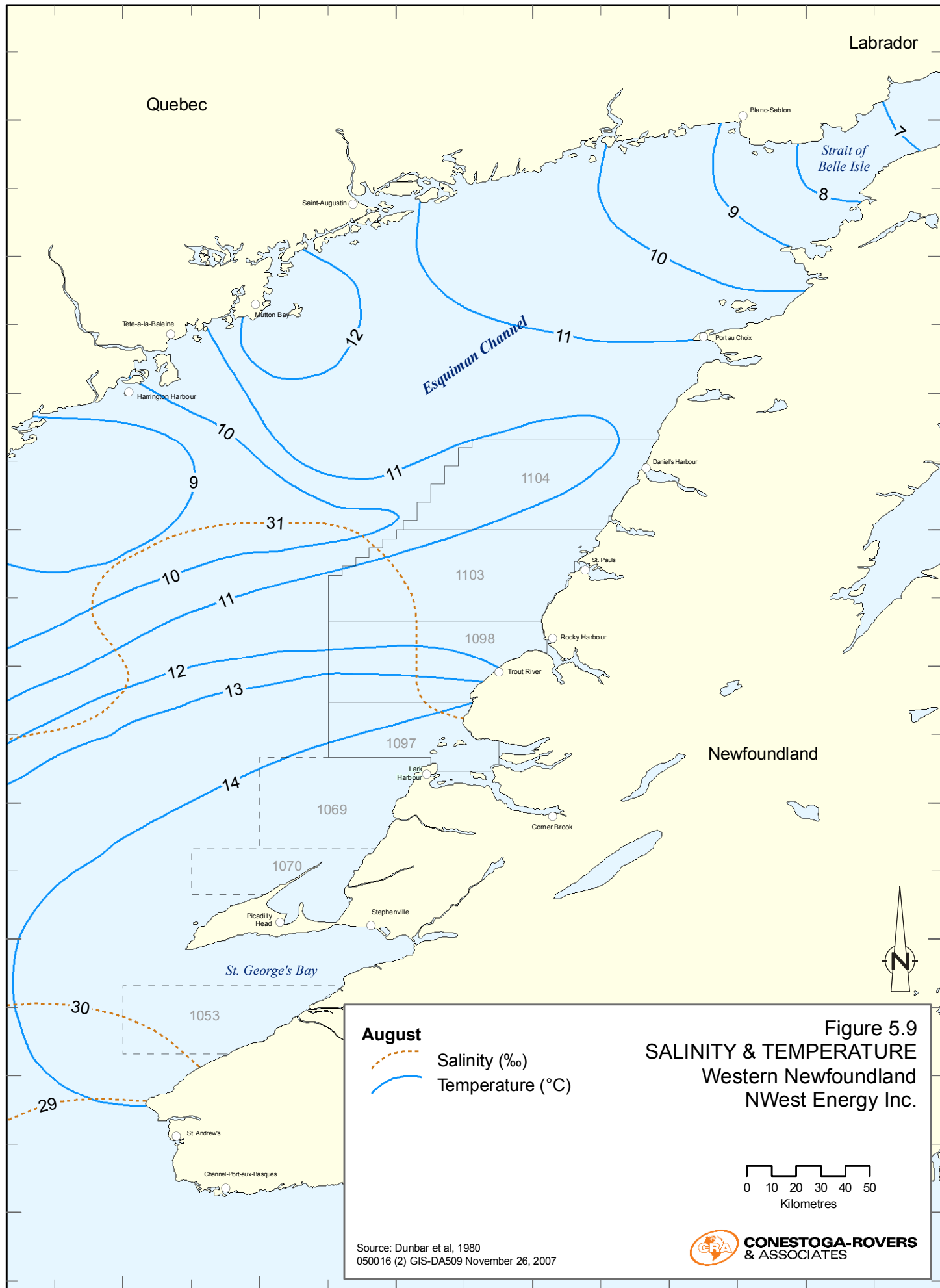
0 10 20 30 40 50  
Kilometres

Source: Dunbar et al, 1980  
050016 (2) GIS-DA508 November 26, 2007

**CONESTOGA-ROVERS & ASSOCIATES**

51.500000  
51.000000  
50.500000  
50.000000  
49.500000  
49.000000  
48.500000  
48.000000  
47.500000

-59.500000 -59.000000 -58.500000 -58.000000 -57.500000 -57.000000



51.500000  
51.000000  
50.500000  
50.000000  
49.500000  
49.000000  
48.500000  
48.000000  
47.500000

Figure 5.9  
SALINITY & TEMPERATURE  
Western Newfoundland  
NWest Energy Inc.

**August**  
- - - Salinity (‰)  
— Temperature (°C)

0 10 20 30 40 50  
Kilometres

Source: Dunbar et al, 1980  
050016 (2) GIS-DA509 November 26, 2007

 **CONESTOGA-ROVERS  
& ASSOCIATES**

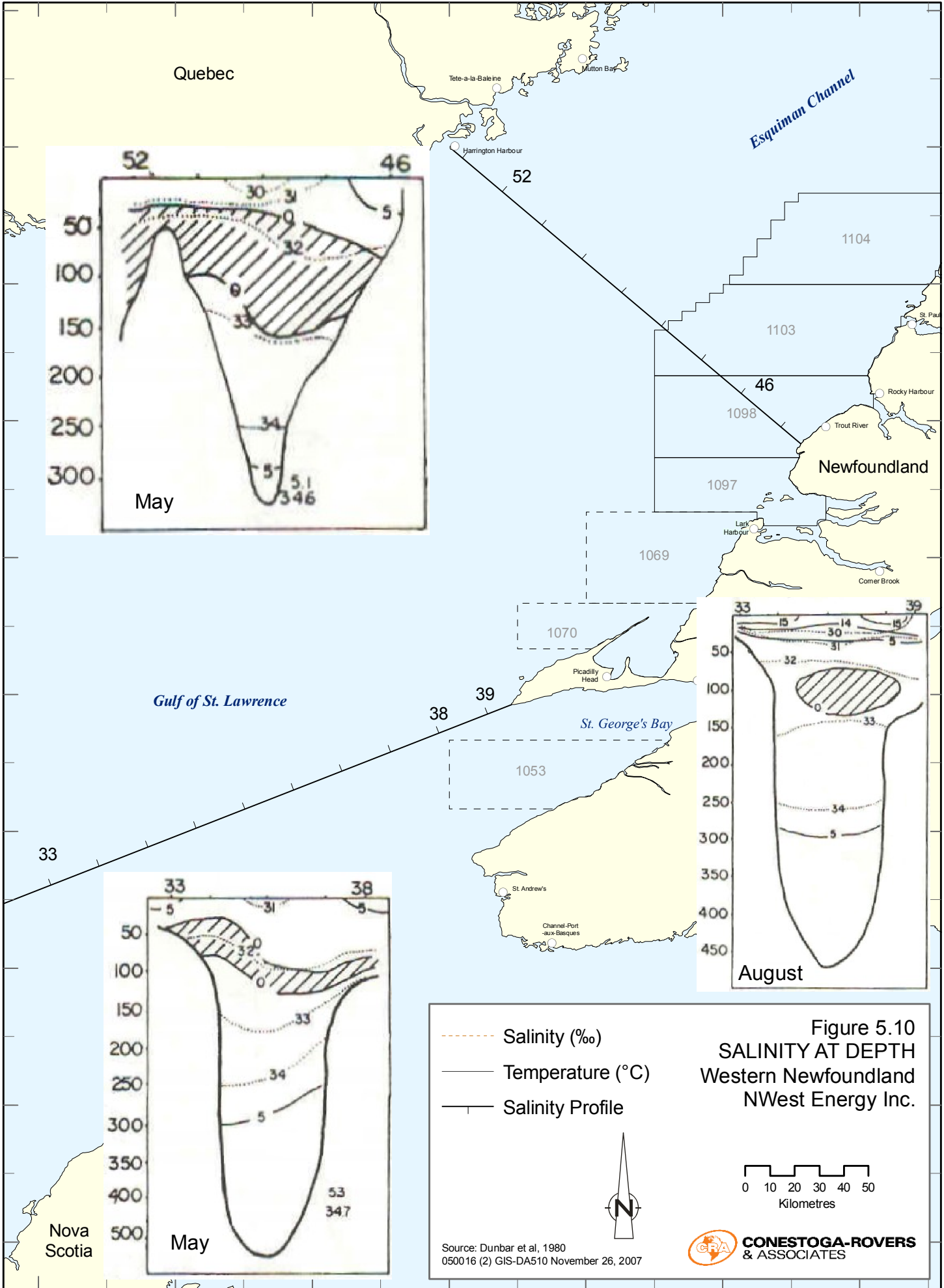
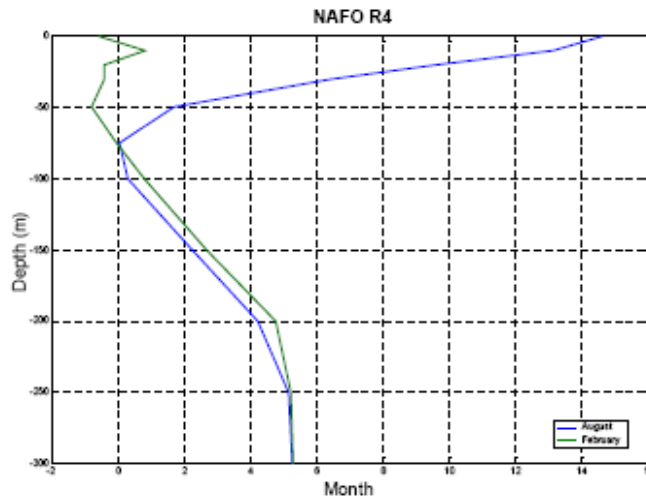


Figure 5.10  
SALINITY AT DEPTH  
Western Newfoundland  
NWest Energy Inc.





**Figure 5.11 Average Vertical Temperature Distribution in NAFO 4R in August and February**

A surface layer of relatively low salinities and seasonally variable thickness are a distinctive element of the water in the Gulf of St. Lawrence. As ice forms in the winter, salt is expelled into the water, resulting in high salinity brines which sink into deeper water. Ice melt in spring provides a significant fresh water source at the surface (Figure 5.11). Surface salinity is between 30 to 31‰, and 34‰ in the deep water layer.

### 5.1.6.2 Waves

Details on wave climate are provided in Section 2.3.5 in the LGL Limited *et al.* (2005) SEA report (pgs 33 to 35). Wave data is based on the AES-40 data set (Swail *et al.* 1999; Swail and Cox 2000) that contains 49 years (1954 to 2003) of climatology data for a number of points in the Gulf of St. Lawrence. The Project Area is in a coastal region, swells only occur from an offshore direction, southeast to northeast.

In summary, storms most often occur between late-August and October. Hurricanes are typically reduced to tropical or sub-tropical storm forces. Highest waves typically occur between October and January. The maximum wave height of 9.43 m was recorded in January. Significant wave heights greater than 5 m occur in every month except for June, July and August. Mean monthly wave height at Grid Point 5817 ranged from 0.58 in March to 1.98 m. in December.

### 5.1.6.3 Currents

Currents of the western coast of Newfoundland are the result of water exchange between the waters entering the Gulf at the Cabot Strait and exiting the Gulf at the Cabot Strait and Strait of Belle Isle. The current in the Gulf of St. Lawrence is cyclonic (*i.e.*, counter clockwise) and also influenced by multiple factors including tides, local and regional meteorological events, freshwater runoff which create mesoscale and synoptic eddies off the west coast. Existing current data from one moored current meters (MCM) in the Gulf of St. Lawrence and five MCM in the Bay of Islands area are available in the vicinity of the Project Area (Bedford Institute of Oceanography 2003) (Figure 5.12). The meter in the Bay of Islands area provided current data for May 1991 to September 1991 at 106 m depth. The meter from the Gulf of St. Lawrence provided current data for October 1995 to April 1996 at 192 m depth. The mean monthly surface current in the Project Area ranged from 0.001 m/s (May/August - Bay of Islands area) to 0.054 m/s (0.11 knots) (February - Gulf of St. Lawrence). The maximum current speeds ranged from 0.110 m/s (October - Gulf of St. Lawrence) to 0.375 m/s (0.73 knots)(March - Gulf of St. Lawrence).

### 5.1.6.4 Tides

The semi-diurnal (two high tides daily) and diurnal (one high tide daily) tides from the North Atlantic enter the Cabot Strait and the Strait of Belle Isle and propagate counterclockwise around the Gulf of St. Lawrence (Dunbar *et al.* 1980). Tidal amplitude is not large in the Gulf and varies between 0.46 m and 0.53 m in the Project Area. Thus, there is no great development of an intertidal zone. Pronounced increases in water levels along ocean coasts may be associated with the passage of storms (storm surge).

### 5.1.6.5 Ice

Floating ice is present in two forms in the marine environment: sea ice and icebergs. Both types pose a potential hazard to vessels. The initial survey in 2008 is scheduled to start August 1 and could take up to between 65 to 75 days to complete, therefore sea ice will not be an issue. Future geophysical survey activity after 2008 could take place anytime, depending on the situation at hand.

-59.000000

-58.500000

-58.000000

-57.500000

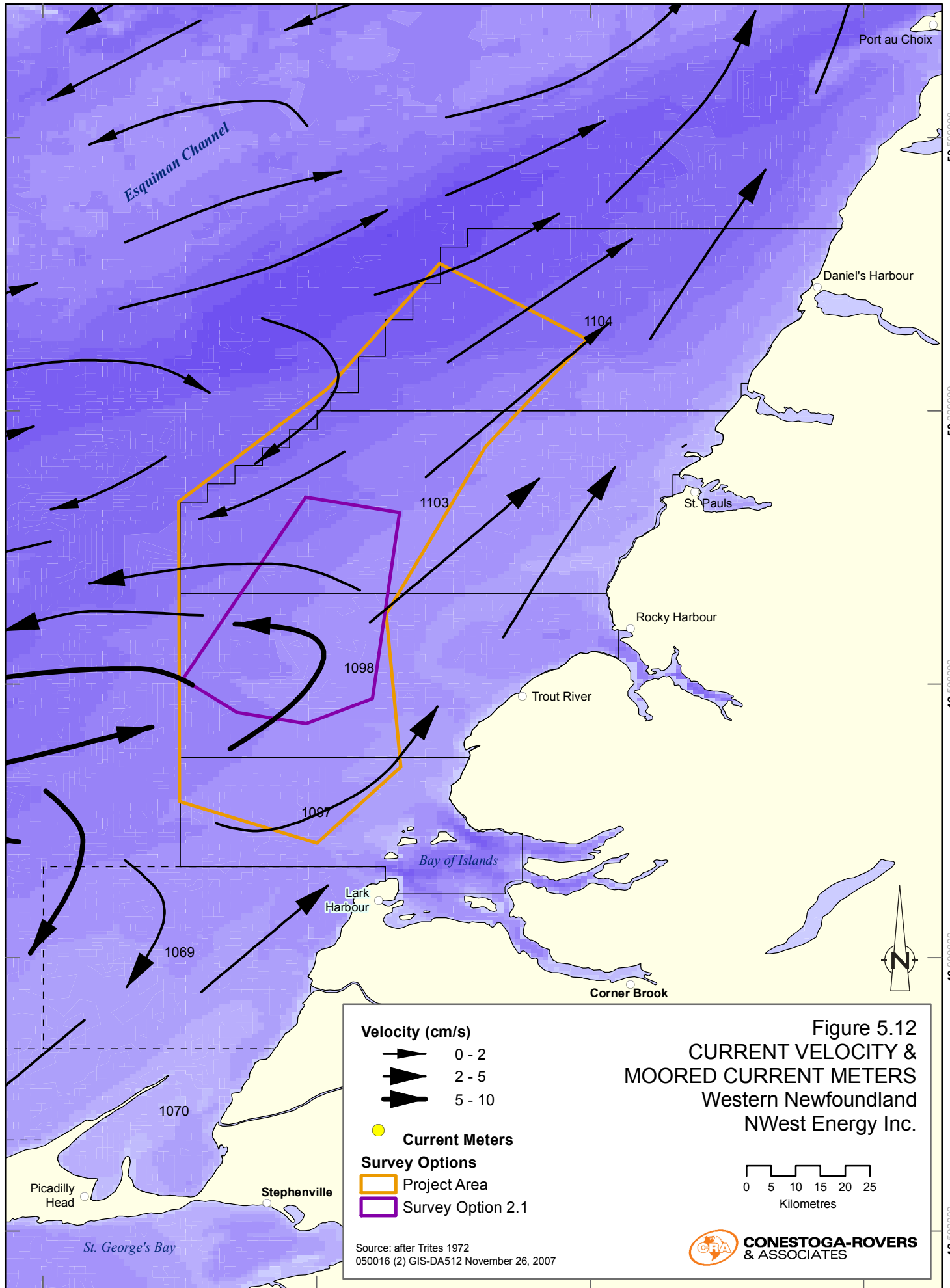


Figure 5.12  
**CURRENT VELOCITY &  
 MOORED CURRENT METERS**  
 Western Newfoundland  
 NWest Energy Inc.

**Velocity (cm/s)**

- 0 - 2
- 2 - 5
- 5 - 10

**Current Meters**

**Survey Options**

- ▭ Project Area
- ▭ Survey Option 2.1

Source: after Trites 1972  
 050016 (2) GIS-DA512 November 26, 2007

50.500000  
50.000000  
49.500000  
49.000000  
48.500000

Ice comes from three sources:

- Labrador ice from the north drifting through the Strait of Belle Isle;
- Ice from the St. Lawrence River and Estuary; and
- Ice formed in the Gulf.

The severity of ice varies relatively, depending on the strength and the vector of direction of the wind and the coldness from the air. Over the Gulf, the greatest average ice thickness is 16 cm in February and can vary up to one metre in the Esquiman Channel. In a common year, ice enters the Strait of Belle Isle by the start of January. The ice edge usually reaches Notre Dame Bay by the end of the month and Cape Freels in the middle of February. The ice edge is at its maximum southern extent by March, and fills the several bays and coves. By April, the rate of melting overtakes the southward ice drift and the pack slowly returns. Usually by mid-month, navigation via the Strait of Belle Isle is possible. In mid-June the median ice edge returns to the mid-Labrador coast. In extreme years, ice can linger south of Belle Isle after Canada Day.

The ice break-up times are based on a 30 year median 1971 to 2000 (Figure 5.13). A review of ice data for the first weeks of April, May and June 1970 through 2007 has shown that ice is variable from year to year. April ice is prevalent in deeper water from the middle of the Esquiman Channel and west to the Quebec shore. The data indicates that most of the area included in the license blocks is open water or ice free about 60% of the time in April. By the first week of May, data show a similar situation with about 40% ice in deeper water, but a higher prevalence of bergy water in the Project Area. In the first week of June, pan ice is present about 10% of the time and bergy water about 50% in the Esquiman Channel.

The ice concentration is the ratio expressed in tenths describing the area of the water surface covered by ice as a fraction of the whole area. By mid-May, the Project Area is 1/10th concentration based on a 30 year median.

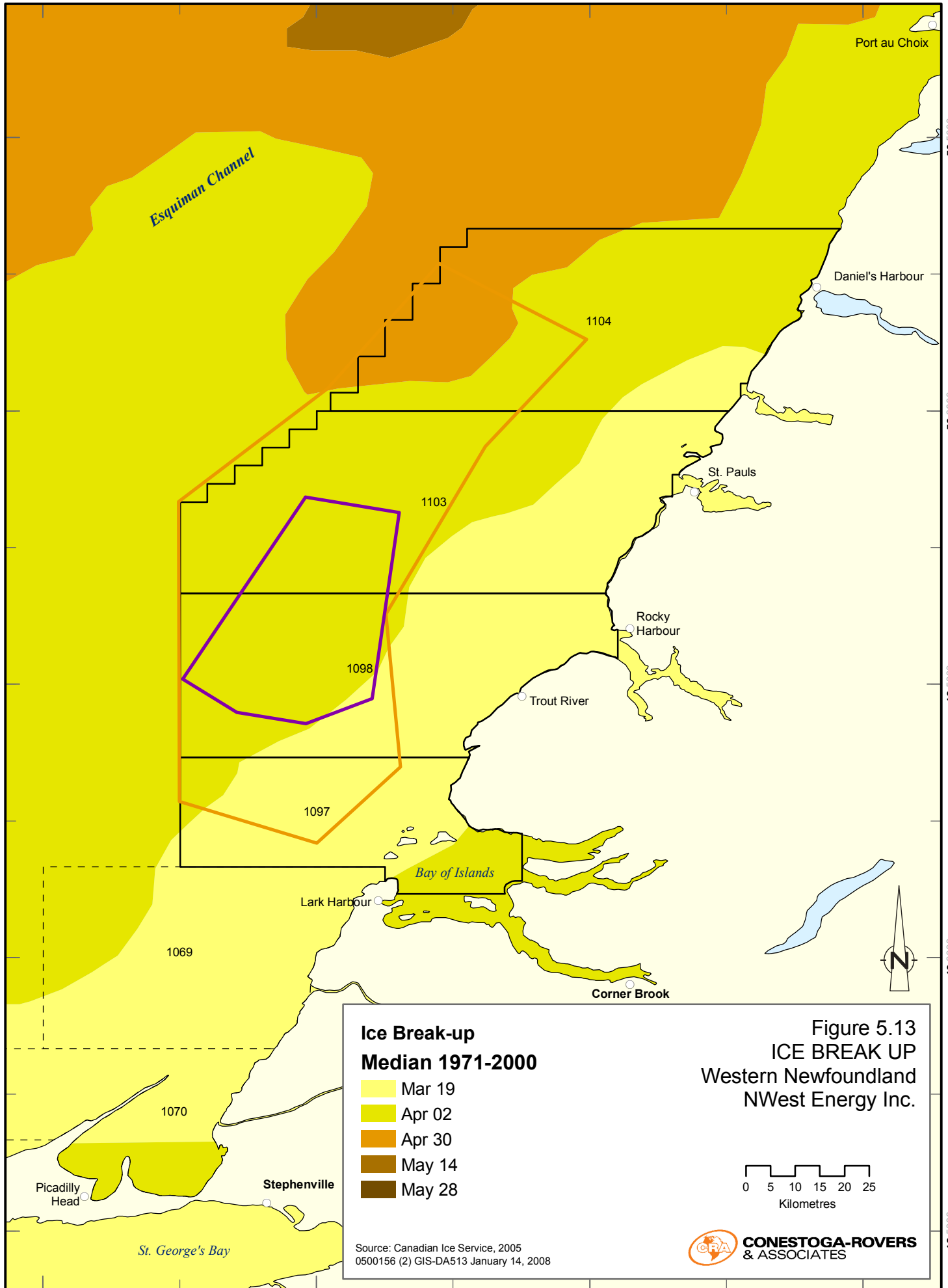
Most icebergs enter the coastal and offshore waters of eastern Newfoundland. During late winter and early spring icebergs may occasionally enter the Gulf of St. Lawrence through old ice floes entering the Gulf from the Labrador Sea. About 10% enter the Strait of Belle Isle and drift into the Gulf of St. Lawrence towards Anticosti Island (Woodworth-Lynas *et al.* 1992).

-59.0000

-58.5000

-58.0000

-57.5000



50.5000

50.0000

49.5000

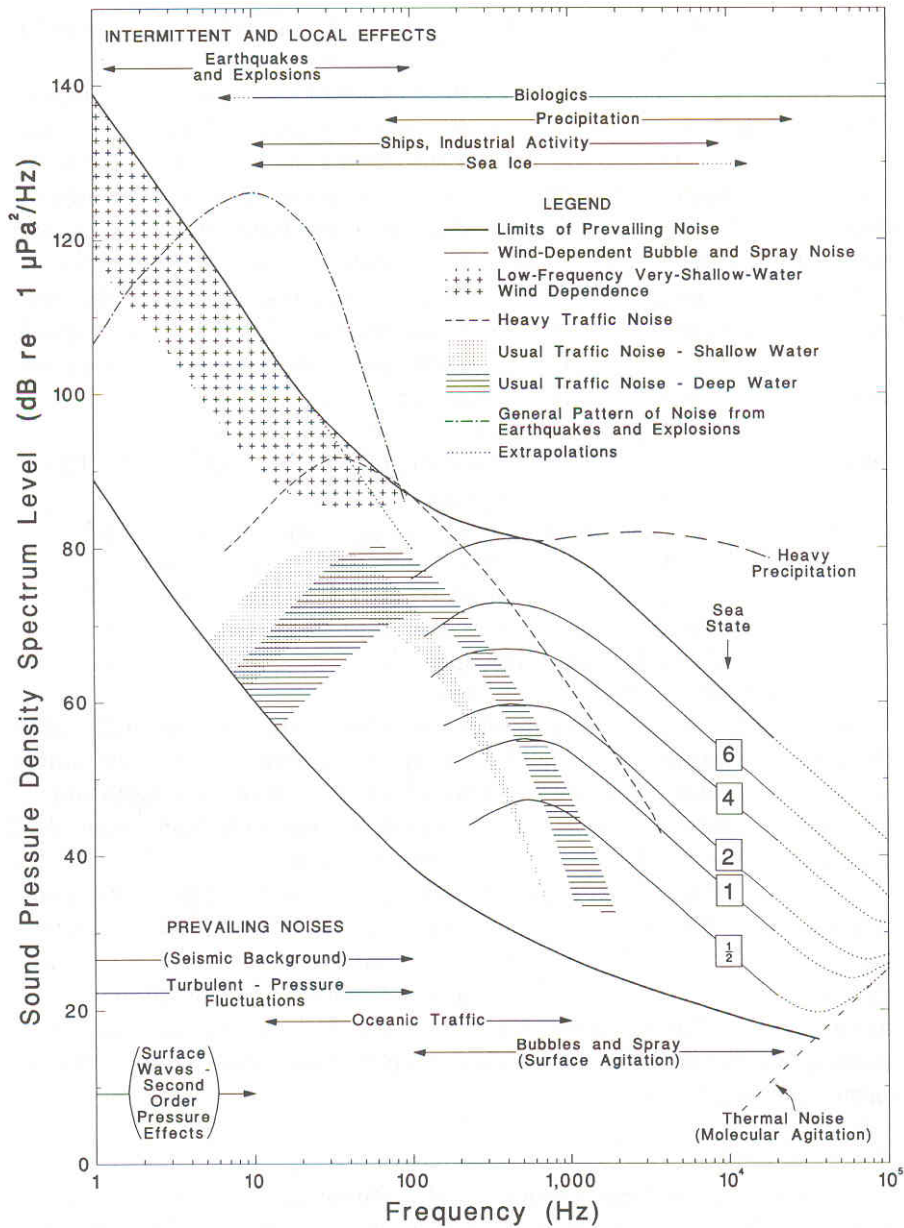
49.0000

48.5000

### 5.1.7 Noise Environment

Sound is generated by many sources, and in the uppermost part of the ocean, weather has a significant impact on the sound level. Marine mammals use sound for communication and navigation, and locally this will add to the background sound level. Human activities will cause a significant amount of sound in the ocean, from activities like commercial shipping, leisure vessels, fishing, seismic surveys, industrial activities, and military activities. Wenz (1962) published a thorough study of noise in the ocean, and a composite of his conclusions are given in Figure 5.14. The figure also gives the limits of prevailing noise, showing that for the frequency band 10 to 100 Hz, the noise level is between 40 and 100 dB, but with a strong increase with lower frequencies. At sound frequencies below 500 Hz, shipping noise is an important factor and above 500 Hz, wind and wave conditions are the primary cause of deep ocean ambient noise (Davis *et al.* 1998).

Most of the man-made noise is continuous signals, such as from shipping etc. Industrial activities and oil exploration create repeated signals of short duration, such as explosions and seismic signals. Only the latter will be discussed in more detail in this report.



**Figure 5.14 Ambient noise spectra attributable to various sources (Wenz 1962)**

Within deep oceanic waters far from shipping lanes, a sound level of 95 dB re 1  $\mu\text{Pa}$  can be assumed as ambient (Richardson *et al.* 1995) with considerably higher levels occurring closer to shipping lanes. Depending on proximity to shipping lanes, Urick (1983) gives values for oceanic waters equivalent peak-to-peak noise levels of 75 to 95 dB re 1  $\mu\text{Pa}$ . In coastal shipping and harbours where human activity is concentrated, ambient noise in shallow, continental shelf waters (< 200 m) has a higher variance. Normal peak levels of ambient noise range from 110 to 120 dB re 1  $\mu\text{Pa}$  in shallow, continental shelf waters

(Richardson *et al.* 1995) and is dependent on oceanographic conditions, shipping and anthropogenic activities.

## 5.2 Marine Resources

This section presents an overview of the Project Area ecosystem with emphasis on valued environmental components (VECs). The VECs include marine and migratory birds, marine fish and shellfish, marine mammals, marine turtles, Species at Risk (SAR), and sensitive areas as listed in C-NLOPB Scoping Document.

### 5.2.1 Plankton

Plankton are free-floating or drifting animals and plants in the open water having their lateral and vertical movements determined by water motion. Plankton are subdivided into phytoplankton - free-floating plants; zooplankton - free-floating animals; and bacterioplankton - minute bacteria and blue-green algae.

Phytoplankton comprise an ecologically important diverse group of plant species: diatoms, dinoflagellates, coccolithophorids and cryptomonads. This group is called primary production and supports most trophic levels in the ocean including fish, marine mammals and seabirds. In the eastern parts of the Gulf, conditions are oceanic or maritime, rather than estuarine; high phytoplankton productivity (50 to 200 mgC/m<sup>2</sup>/hr) occurs in the early spring (April to May) using nutrients available by winter turnover, followed by lower values (<50 mgC/m<sup>2</sup>/hr) for the remainder of the season (Dunbar *et al.* 1980).

Zooplankton include the secondary producers, herbaceous (copepods) plankters which support tertiary producers, the predacious animal (cnidarians, ctenophores, fish larvae) plankters. Copepods comprise more than 75% of the zooplankton species in the Gulf (Runge and de Lafontaine 1996). In the deep and cold waters of northern Gulf, large species of *Calanus* dominate. Dominant zooplankton in the Saguenay of Belle Isle area include *Calanus finmarchius*, *C. glacialis*, *Pseudocalanus* sp., *Oithona similis* and *Temora longicruris* (de Lafontaine *et al.* 1991). The effects of the proposed Project on plankton are not specifically assessed in the EA Report due to their ubiquitous distribution and abundance. Fish eggs and larvae are further assessed as part of the broader consideration of marine fish.

Ichthyoplankton is another type of zooplankton and include both the eggs and larvae of most fish (including shellfish). Ichthyoplankton in the Gulf is dominated by larvae from



benthic eggs. Fifty species of ichthyoplankton are found in the Gulf, representing two-thirds of the adult fish species in the region (White and Johns 1997). Sand lance larvae dominate the northeastern Gulf in May, followed by larvae of redfish and capelin in late June (de Lafontaine 1990, de Lafontaine *et al.* 1991, Runge and de Lafontaine 1996). Cod, herring and American plaice larvae occur in shallow coastal waters of the northeastern Gulf region although less abundant than important forage fish listed above on which fish, seabirds and marine mammals feed upon. The distribution of lobster, herring and scallop larvae are limited to coastal pelagic zones. Species richness was greater (with radiated shanny, cunner, winter flounder larvae) in shallow water stations but larvae density was lower than deep water stations (Runge and de Lafontaine 1996).

Important retention areas occur along the western coast of Newfoundland. A productive hot spot has been identified by fishers and referred to as “The Hole”. This site is located off Port au Choix, north of the Project Area. The steep slope of the Esquiman Channel creates an area of upwelling of nutrients which creates an environment to support a concentrated area for zooplankton. As prevailing water currents determine the drift of larvae from spawning to nursery areas. Lobster nursery areas important during the summer months are present at North Head and Trout River Bay. A cod spawning area is located off Port au Port for 4RS and 3Pn cod in the spring.

Bacterioplankton abundance is highest at the sea surface. Bacteria in the oceans’ depth decreases with depth except in sediments rich in organics or near hydrothermal vents. Their role in the food chain is recycling elements and organic material (Parsons *et al.* 1984).

### **5.2.2 Marine and Migratory Birds**

Information on distribution, species habitats, feeding, breeding and migratory characteristics are summarized from the Western Newfoundland and Labrador Offshore Area Strategic Environmental Assessment (LGL Limited *et al.* 2005) and information from Canadian Wildlife Service (CWS) in the scoping document.

The waters and adjacent landforms of the west coast off Newfoundland are inhabited by a diverse assemblage of resident and migratory birds. Marine avifauna are subdivided into three categories: (1) pelagic seabirds, (2) coastal waterfowl, and (3) shorebirds.

## Pelagic Seabirds

The marine coast and waters of western Newfoundland have lower abundances of pelagic seabirds than other coastal areas of Newfoundland likely because of the lack of breeding habitat along the west coast, the lower productivity of the adjacent waters compared to the east coast and they are less influenced by the major oceanic currents (Lock *et al.* 1994). Seabird families in the area include shearwaters, fulmars, petrels, jaegers, skuas, gannets, cormorants, alcids, kittiwakes and gulls. Phalaropes, although a shorebird, are included here as they are a pelagic seabird during the non-breeding season and do not breed in the Affected Area. Only the large gulls, terns and gannets are reported common in the Affected Area; however, some relatively large seabird colonies (*e.g.*, Northern Gannets, Razorbills, Common Murres, and lesser numbers of Atlantic Puffins) that occur along the Quebec North Shore (Rail and Chapdelaine 2002) utilize pelagic water in the Affected Area.

Figures 5.15 to 5.18 show the distribution of vulnerable pelagic seabirds over the year. The period between January and March is the peak of vulnerability to oil pollution (in terms of concentrations) for seabirds in the Affected Area (Figure 5.15). The highest abundance of seabirds during between January and March occurs at the southern part of the Affected Area, particularly in the vicinity EL 1097; however, greater than 10 birds/km line are present on the periphery of ELs 1103 and 1104 during this period. Less than 10 birds/km line are vulnerable to oil pollution in coastal areas adjacent to the western coast of Newfoundland from April to September. Seabirds are least abundant in the Project Area during October to December (Figure 5.18) (Lock *et al.* 1994).

Cormorants, Common Terns (*Sterna hirundo*), Arctic Terns (*Sterna paradisaea*), Great Black-backed Gulls (*Larus marinus*), Herring Gulls (*Larus argentatus*), Ring-billed Gulls (*Larus delawarensis*), Black-legged Kittiwakes (*Rissa tridactyla*), and Black Guillemots (*Cepphus grylle*) nest in small colonies scattered along the coast in the Affected Area. Within the Affected Area, known seabird colonies occur at White Rocks, Stearing Island, Little and Middle Islands at St. Paul's Inlet (Lock *et al.* 1994) and several locations within the Bay of Islands area (Tweed Island, Green Island, Gregory Island, Saddle Island, Hen Island) based on aerial surveys conducted in 2002 by the CWS (Figure 5.19). CWS aerial surveys indicated relatively larger concentrations of terns, gulls and kittiwakes (total individuals) at Bay of Islands in EL 1097 and St. Paul's Inlet in EL 1103 (mostly Little Island, Middle Island and Western Island). Lock *et al.* (1994) did not identify any colonies in the Affected Area that were vulnerable to oil pollution but this reflects the lack of information for this geographic area. Caspian Terns (*Sterna caspia*), currently listed as a species of concern by the Committee on the Status of Endangered Wildlife in

Canada (COSEWIC), may occur in the Affected Area at low numbers but no known areas have been identified.

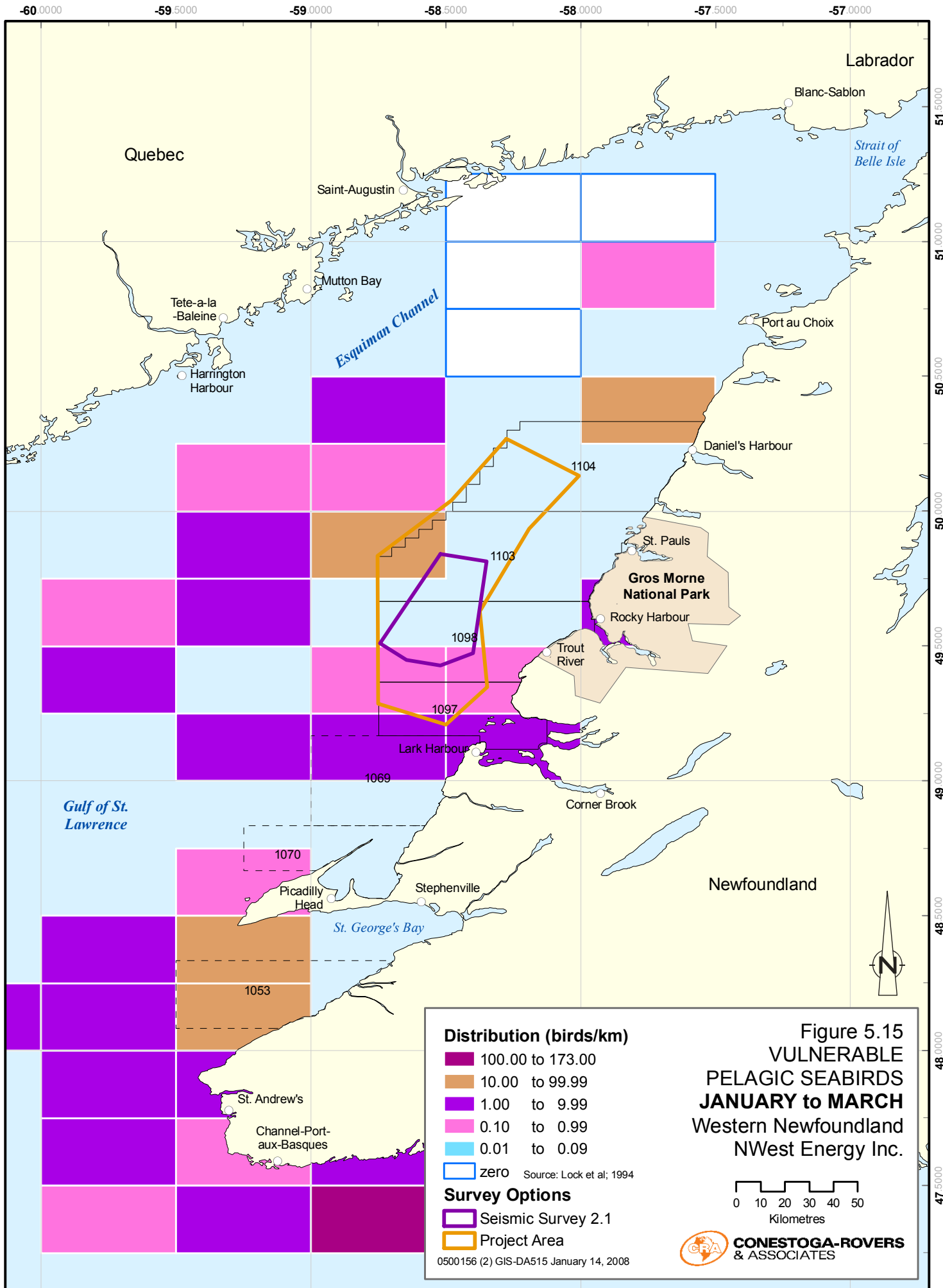
There are small colonies of Double-crested Cormorant (*Phalacrocorax auritus*) and Great Cormorant (*Phalacrocorax carbo*) near Cape Anguille, Saddle Island, Gregory Island in the Bay of Islands in EL 1097 and the northern portion of Gros Morne National Park in ELs 1098 and 1103 (Figure 5.19). Small colonies of seabirds including Black Guillemots (Lock *et al.* 1994) and Atlantic Puffins (Cairns *et al.* 1989) also nest along the coast in the Bay of Islands. Several of these islands are used from April to October for egg laying and brood rearing by these species. Table 5.2 provides estimated numbers of pairs of colonial, marine-associated birds and bird species of conservation concern nesting in coastal Western Newfoundland in the vicinity of the Project Area.

**Table 5.2 Estimated Number of Nesting Pairs in Nesting Areas Within Important Bird Areas**

Species	Guernsey Is.	Gregory Is.	Middle Is., St. Paul's Inlet	Little Is., St. Paul's Inlet	White Rock & Stearing Is.
Great Cormorant	19				
Ring-billed Gull					6
Herring Gull	165				
Black-legged Kittiwake		500			
Arctic Tern			15	20	
Common Tern			135	180	
Unidentified Tern					200
Black Guillemot					10
<b>Totals</b>	<b>184</b>	<b>500</b>	<b>150</b>	<b>200</b>	<b>216</b>

Seabirds nesting in the Affected Area are long-lived and have relatively low rates of population growth. Egg-laying commences in mid to late May and into June, and most species are fledged by July/August with Northern Gannets fledging into October/November (see Table 3.13; LGL Limited *et al.*, p.151).

Foraging strategies of these seabird groups vary from plunge diving (gannets) and pursuit diving (alcids) to surface feeding (phalaropes) and kleptoparasitism (jaegers and skuas). Cormorants are pursuit feeders and fed primarily on capelin, mackerel, and short-finned squid. Some species such as terns and phalaropes specialize in foraging in shallow depths at the surface, feeding on fish (*i.e.* capelin), amphipods, and copepods. Alcids are pursuit divers may dive to great depths (20 to 50 m) to feed on fish and invertebrates. Fish, crustaceans, cephalopods, and fish offal comprise the main prey, and foraging strategies of surface feeding gull species.



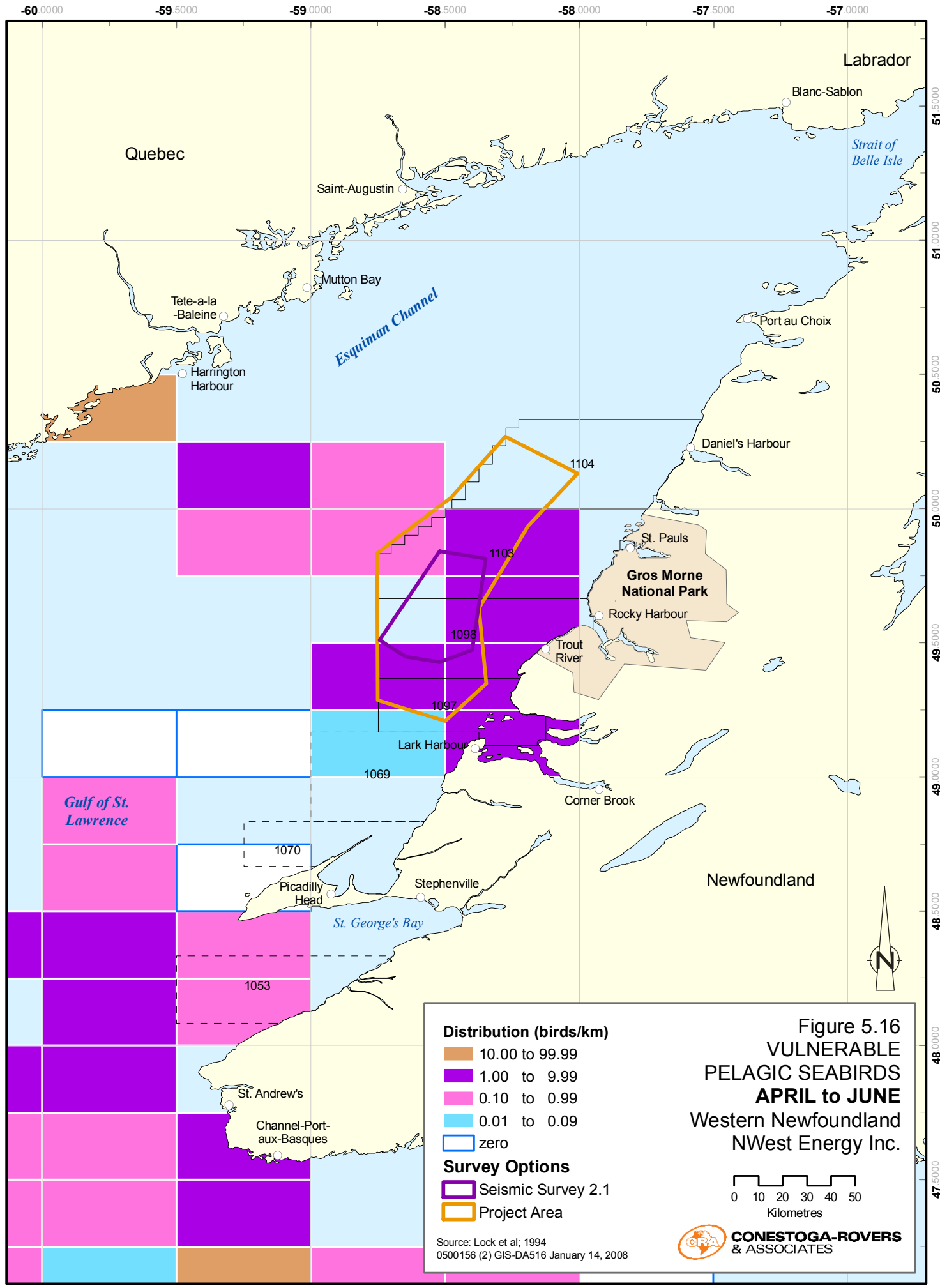


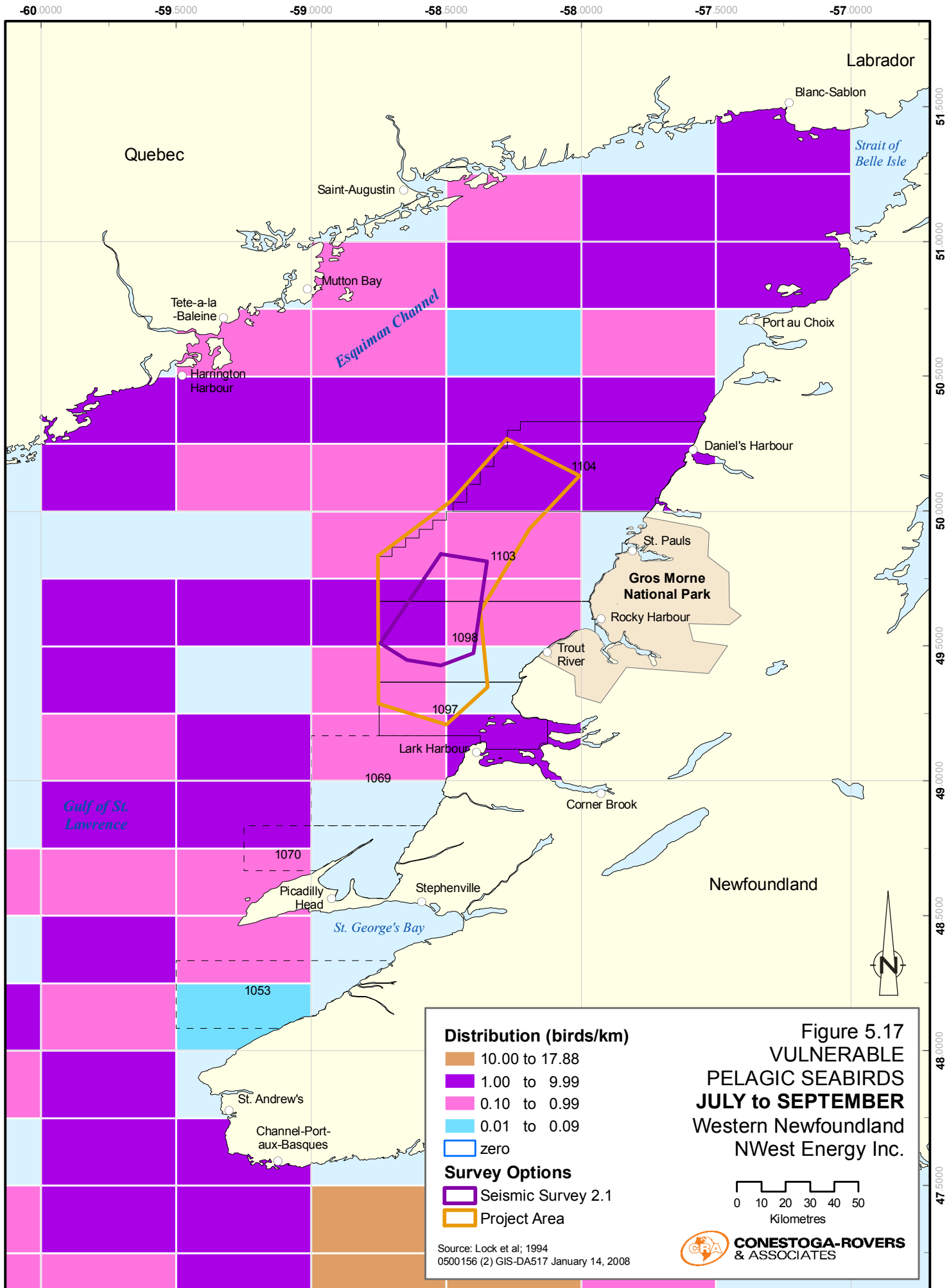
Figure 5.16  
**VULNERABLE  
 PELAGIC SEABIRDS  
 APRIL to JUNE**  
 Western Newfoundland  
 NWest Energy Inc.

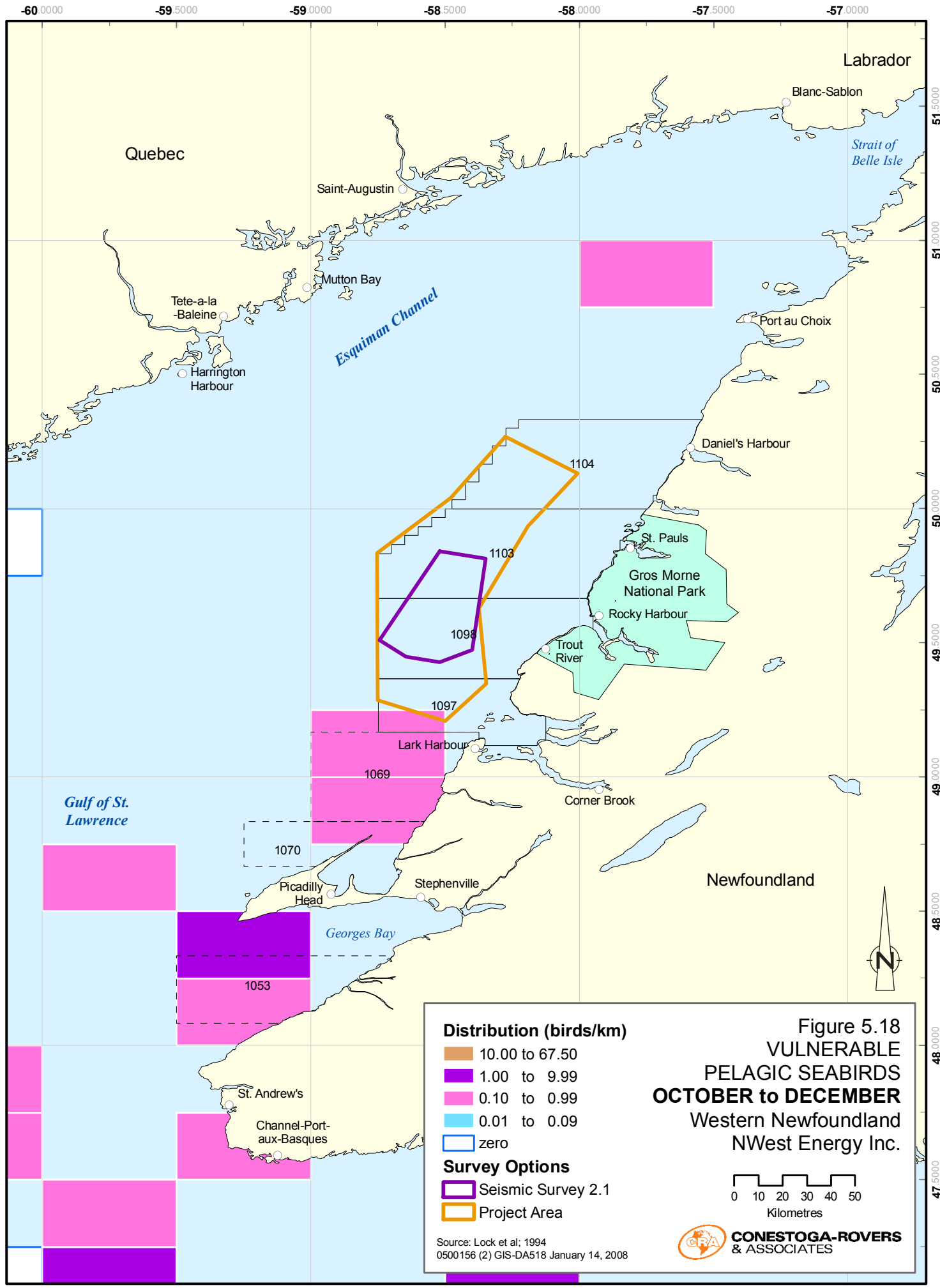
**Distribution (birds/km)**  
 10.00 to 99.99  
 1.00 to 9.99  
 0.10 to 0.99  
 0.01 to 0.09  
 zero

**Survey Options**  
 Seismic Survey 2.1  
 Project Area

Source: Lock et al; 1994  
 0500156 (2) GIS-DA516 January 14, 2008







## Coastal Waterfowl

The west coast of Newfoundland has not been systematically searched for coastal waterfowl; however, aerial surveys conducted by CWS in 2002 discovered several nesting colonies of Common Eider (*Somateria mollissima*) in the Bay of Islands area in EL 1097, including Hen Island, Gregory Island, and several other small islands (Figure 5.19) and also at Stearing Island at St. Paul's Inlet.

Some relatively large areas of staging waterfowl, especially Canada Geese (*Branta canadensis*) and American Black Ducks (*Anus rubripes*), occur at St. Paul's Inlet and Parsons Pond (Figure 5.19). Diving ducks such as Common Goldeneye (*Bucephala clangula*) and Merganser species (*Mergus* spp.) are common throughout the Affected Area and may also support the uncommon Greater Scaup (*Aythya marila*). Common Loons (*Gavis immer*) winter in the regions that remain ice-free in the Affected Area. Species such as Red-throated Loons (*Gavia stellata*) and grebes (*Podicipedidae*) are relatively uncommon in the Affected Area. The majority of overwintering waterfowl occur in the rich estuarine marshes south of the Project Area.

The eastern population of Harlequin Duck was listed as endangered in 1990 (Goudie 1991), and are currently listed by the *Species at Risk Act* (SARA) as a species of concern. Breeding areas occur in watersheds draining the Long Range Mountains (Robertson and Goudie 1999). The only coastal aggregation of Harlequin Ducks (<100) identified in the Affected Area is a small concentration that moults in late summer-early fall off Stearing Island off Cow Head near Gros Morne National Park (Figure 5.19). This stage of vulnerability is temporary over a one month period. Species at risk are discussed in more detail in Section 6.5.

## Shorebirds

Many migrant shorebird species occur within the Affected Area with the majority occurring in the mid to late August to early September (Lock *et al.* 1994). The most abundant shorebirds species in the Affected Area are the Semipalmated Sandpiper (*Calidris pusilla*), White-rumped Sandpiper (*Calidris fuscicollis*), Greater Yellowlegs (*Tringa melanoleuca*), Black-backed Plover (*Pluvialis squatarola*), Semipalmated Plover (*Charadrius semipalmatus*) and to a lesser extent, the Least Sandpiper (*Calidris minutilla*), Ruddy Turnstone (*Arnaria interpres*) and Sanderling (*Calidris alba*). The largest concentration of migrant shorebirds in the Affected Area identified by Lock *et al.* (1994) occurs at ELs 1098 and 1103 including Bonne Bay, St. Paul's Inlet and Parsons Pond (Figure 5.19).



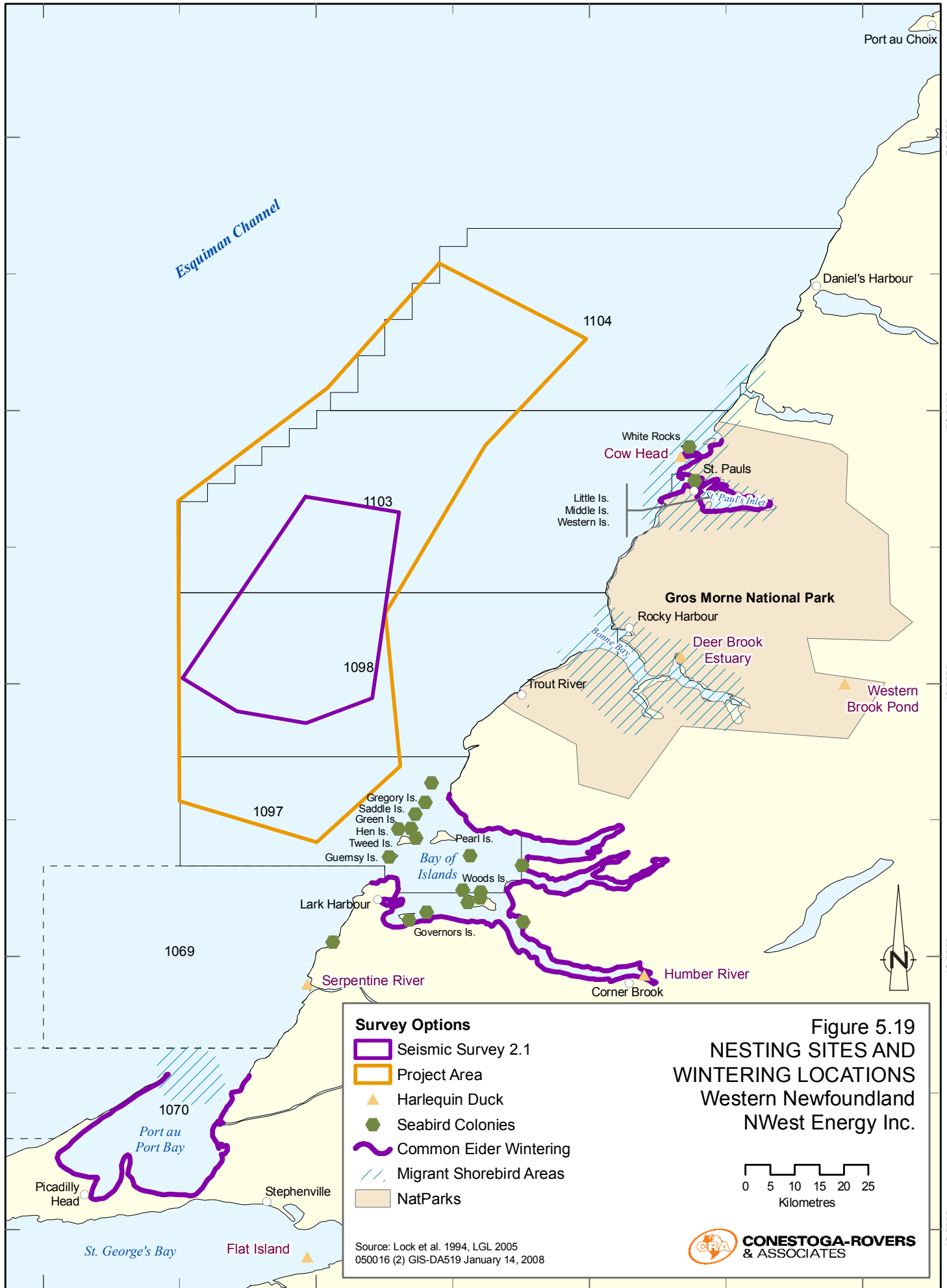


Figure 5.19  
 NESTING SITES AND  
 WINTERING LOCATIONS  
 Western Newfoundland  
 NWest Energy Inc.

**Survey Options**

- Seismic Survey 2.1
- Project Area
- Harlequin Duck
- Seabird Colonies
- Common Eider Wintering
- Migrant Shorebird Areas
- NatParks

Source: Lock et al. 1994, LGL 2005  
 050016 (2) GIS-DA519 January 14, 2008

50.5000  
 50.0000  
 49.5000  
 49.0000  
 48.5000

## **Important Bird Areas**

The Important Bird Area (IBA) program identifies habitat important to the survival of bird species. The program is coordinated by BirdLife International and administered in Canada by Bird Studies Canada and the Canadian Nature Federation ([www.ibacanada.com](http://www.ibacanada.com)). The criteria used to identify important habitat are internationally standardized and are based on the presence of threatened and endangered species, endemic species, species representative of a biome (keystone species), or a significant proportion of a species' population. These criteria focus on sites of national and international importance. One coastal site in the Affected Area, Gros Morne National Park (adjacent to EL 1103), has been identified with the IBA designation (Figure 5.19).

At least 207 bird species have been recorded in the park, of which Common Tern and Arctic Tern occur along the coast (Lamberton 1976). Both species nest on two offshore islands, Stearing Island and the White Rocks, off the coast of Gros Morne National Park (Lock *et al.* 1994) and are each designated sensitive by the provincial government. The eastern Canadian population of the Harlequin Duck, a species of concern on Schedule 1 of *SARA*, also occurs here on turbulent rivers and streams in the park. Some broods congregate where the breeding streams drain into coastal waters before and after the nesting season, and a small concentration (<100) moults at Stearing Island (Thomas and Robert 2001; Lock *et al.* 1994). Relatively large aggregations of shorebirds and waterfowl occur during migration in St. Paul's Inlet, and Piping Plover likely bred there up to recent times.

### **5.2.3 Benthic Habitat**

The seafloor surficial geology is varied in the Project Area and hence creates a variety of habitat, much more so than the overlying open water. Primary production occurs by benthic aquatic algae (seaweeds). Benthic animals are mostly invertebrates and are divided into infaunal (in the seafloor) and epifaunal (on the seafloor or attached to it and objects), as they are potentially most affected by disturbances to the seabed they deserve important consideration. They generally constitute the lower trophic levels and are therefore an essential link to higher trophic levels such as fish, birds and mammals.

Several literature reviews of coastal benthic resources of Newfoundland and Labrador are available (Dunbar 1980, MacLaren 1977, South *et al.* 1979, Barrie and Browne 1980, Campbell and Sutterlin 1981, Thompson and Aggett 1981, LeDrew 1984, Hardy 1985, Gilkinson 1986). Information on the biological environment is partially derived from

Western Newfoundland and Labrador Offshore Area Strategic Environmental Assessment (LGL Limited *et al.* 2005) and Dunbar *et al.* (1980).

### **Intertidal Communities**

Based on a scheme developed for the West Coast Newfoundland Oil Spill Sensitivity Atlas (Dempsey *et al.* 1995), Catto *et al.* (1999) presented intertidal biological shoreline units that were designated on the basis of key biological indicators. These include fine and coarse substrate designations:

#### **Course Substrate**

- *Fucus anceps* Surf Zone
- Seabird-dominated Shores
- *Ascophyllum* Rockweed Shores
- Capelin Spawning Beaches
- Temporary Intertidal Communities
- Vertical Biological Zones
- Rockweed Platforms
- Periwinkle Shores

#### **Fine Substrate**

- Saltmarsh
- Eelgrass (*Zostera*)
- Barachois Estuaries

### **Subtidal Communities**

The Dunbar *et al.* report (1980) appears to have the most information on species presence on the western coast of Newfoundland and the Gulf of St. Lawrence, albeit restricted to nearshore and in most cases St. Paul's Harbour.

Seaweeds are the primary producers in the nearshore to about 30 m and they provide shelter and food to invertebrates and fish. Beyond this depth, the benthos is composed mostly of fish and invertebrates. Venting gases of methane and hydrocarbons are a possible food source for the benthic community. Hydrocarbons seepage is a known occurrence along this coast of Newfoundland.

Benthic animals are the main source of food for demersal finfish and shellfish which are the basis for major commercial fisheries, and have importance in processes which release nutrients from sediment (bioturbation). The combined activities of benthic invertebrates and fish have influence on the structure and distribution of sediments through reworking of sediments and zones of dense shell beds.

The till, sand and gravel substrate is indicative of wave and current activity in its general lack of fine-grained sediments. Mud occurs in the northern half of Block 1104 and sand, gravel and tills and predominant in the remaining blocks. Sessile epifaunal animals

include anemones, bryozoans, sponges, possibly soft corals, hydroids and tunicates. Motile animals include brittlestars, sand dollars, sea urchins, sea cucumbers, gastropods, crustaceans, and sea stars.

A small basin of silt and silty sand occurs in EL 1103. Faunal species in finer silty sediments are largely represented by burrowing deposit and suspension feeders - polychaetes. Dominant crustaceans are ostacods, amphipods, isopods, tanaids, mysids and smaller decapods. Molluscs are mainly represented by burrowing bivalves with a few gastropods at the surface. Echinoderms include brittle stars, sand dollars, sea cucumbers, heart urchins and a few predatory sea stars.

## **5.2.4 Marine Fish and Shellfish**

### **5.2.4.1 Demersal Finfish**

Demersal finfish species are fish that live near the seafloor for the majority of their adult lives. They are commonly referred to as groundfish and historically supported the largest fisheries in the western Atlantic. A selection of demersal finfish families known to occur in the Project Area are described here, including the codfishes (Family Gadidae), the flounders (Family Pleuronectidae), the redfishes (Family Scorpaeniidae), and the skates (Family Rajidae).

#### **Atlantic Cod**

Northern Gulf of St. Lawrence cod (*Gadus morhua*) (NAFO Divisions 3Pn and 4RS) undertake extensive migrations. Yvelin *et al.* (2005) describe migration routes and stock of cod based on tagging surveys in the Gulf of St. Lawrence. Those cod which overwinter along the coast of southwestern Newfoundland (4R + 4S + 3Pn) migrate commencing in April, moving towards the Port au Port Peninsula (NAFO UA 4Rcd) near EL 1097 and EL 1098 where spawning commences (DFO 2005a; Ouellet *et al.* 1997). The fish disperse into the northern Gulf of St. Lawrence, the Quebec North Shore and the Strait of Belle Isle during summer (June and July). In the Strait of Belle Isle north of Point Riche in Newfoundland and Blanc Sablon in Quebec, the Gulf cod intermingle with schools of Labrador-east Newfoundland cod. A southerly migration starts in September and October. By winter (January to March), they aggregate off southwestern and southern Newfoundland at depths of more than 400 m (4Rd) (Castonguay *et al.* 1999) and on average, in 100 and 250 m water depth (Yvelin *et al.* 2005). In June, cod are found in shallower water and coastal waters (0-100 m).

In 2002, a new zone was established in 4R to protect the spawning stock. It is a sector where any groundfish capture is prohibited between April 1st and June 15th. During

summer, the cod continue their migration and disperse towards the coastal zones along the west coast of Newfoundland (4R) and towards Quebec's Middle and Lower North Shore (4S). This migration towards the coastal regions appears to be associated with warmer water and the presence of capelin, the primary prey of the cod (DFO 2005a).

The assessment of cod stock in the Northern Gulf (3Pn, 4RS) is conducted annually, primarily in August, based on commercial fishery data and on four abundance indices: three from sentinel fisheries and the other from the DFO's research mission. Resource status is measured by a sequential population analysis model completed by risk analysis in the context of the precautionary approach. According to DFO, the abundance and spawning stock biomass of the northern Gulf stock remain low since 1997, the commercial fishery has been conducted by fixed gears only (longlines, gill nets and handlines) (Fréchet *et al.* 2003). The spawning stock biomass increased between 1994 and 1999, but subsequently declined between 2000 and 2002. Spawning biomass reached a maximum of 378,000 tons in 1983 and dropped to 11,000 tons in 1994. After the first moratorium in 1998, this stock's biomass reached 29,000 tons. Since the fishery was reopened in 1997, the spawning stock biomass varied from 24,000 tons to 44,000 tons without any real sign of recovery. The spawning stock biomass increased by 6% between 2006 and 2007. Exploitation rates rose by 11% in 2004 to 13% in 2005 and to 16% in 2006 in relation with the increase in annual landings (DFO 2007). The results from the sequential population analysis formulation, which estimated natural mortality, indicated that the spawning stock biomass would be 35,000 tons in 2007. Spawning stock biomass estimates are below the conservation limit for this stock. Recruitment contribution towards stock productivity is also concerning.

### **White Hake**

White hake are restricted in distribution to the western Atlantic Ocean from the Gulf of St. Lawrence and the southern part of the Grand Banks of Newfoundland southward to Cape Hatteras. Areas of greatest abundance are the southern Gulf of St. Lawrence, the Scotian Shelf and the southwest slope of the Grand Banks.

In the early stages of its life history, the white hake is pelagic and remains so until it is approximately 8 to 13 cm long. After taking to the bottom they remain groundfish, rising into the upper layers only in pursuit of food. They occur in shallow water as well as in depths over 900 m and are more abundant on soft muddy bottom than on hard rocky ones. They are more stationary than cod and tolerate a wider temperature range (0.6° - 21°C) but avoid regions where the temperature is as low as or lower than 0.0°C. Bottom temperatures at which largest catches have been obtained have been cited as between 3° and 8°C.

Small hake in deep water have an interesting habit of taking refuge within the living shells of the giant scallop. This association is wide spread and well known.

The spawning time for white hake varies over its range. It occurs during summer in the Gulf of St. Lawrence.

### **Redfish**

Redfishes belong to the large family of scorpion fishes. Two species of redfish are regularly found in the Project Area; the Acadian redfish (*Sebastes fasciatus*) and deep water redfish (*S. mentella*). Redfish are a deep water demersal species occurring in cold waters along the slopes of banks and deep channels of 100 to 700 m. This species occurs over a variety of bottom substrates, and displays diurnal movement, rising in the water column to feed at night (Scott and Scott 1988). One of the currently identified concentrations of Gulf of St. Lawrence redfish is located in the Cabot Strait area in 4R (*i.e.* 4Rd) (DFO 2004a).

Mating occurs in the fall. Redfish, unlike most other demersal fish, are ovoviviparous; the eggs hatch within the female, who gives birth to live young between April and July. The larvae are pelagic.

### **Greenland Halibut**

The Greenland halibut (turbot) (*Reinhardtius hippoglossoides*) is a deepwater flatfish species that occurs in water temperatures ranging between -0.5 to 6.0°C, but appears to have a preference for temperatures of 0 to 4.5°C. These fish are normally caught at depths exceeding 450 m in the Northwest Atlantic off northeastern Newfoundland and southern Labrador, but can range from depths of 90 to 1,600 m with larger individuals occurring in the deeper parts of its vertical distribution. Unlike many flatfishes, the Greenland halibut spends considerable time in the pelagic zone (Scott and Scott 1988).

Greenland halibut are believed to spawn in Davis Strait during the winter and early spring at depths ranging from 650 to 1,000 m. They are also thought to spawn in the Laurentian Channel and the Gulf of St. Lawrence during the winter, between January and March. The large fertilized eggs of this species (4.0 to 5.0-mm diameter) are benthic, but the hatched young move upwards in the water column and remain at about 30 m below surface until they attain an approximate length of 70 mm. As they mature, the young fish move downward in the water column and are transported by the currents in the Davis Strait southward to the continental shelf and slopes of Labrador and Newfoundland (Scott and Scott 1988).

### **Atlantic Halibut**

Atlantic halibut (*Hippoglossus hippoglossus*) is the largest of the flatfishes and typically is found along the slopes of the continental shelf. Atlantic halibut move seasonally between deep and shallow waters, apparently avoiding temperatures below 2.5°C (Scott and Scott 1988). The spawning grounds of the Atlantic halibut are not clearly defined. Atlantic halibut in the northern Gulf of St. Lawrence are most abundant in the Esquiman, Laurentian and Anticosti Channels at depths >200 m. Based on observations made during scientific trawl surveys, these halibut are able to spawn in January and May (timing of surveys). Based on tagging studies, Atlantic halibut of this stock do not move far from their home range (DFO 2005e).

### **Witch Flounder**

Witch flounder reach their northern limits in the Northwest Atlantic at the Hamilton Inlet Bank area (54 °N) and have been reported as far south as Cape Lookout, North Carolina. They prefer living in gullies where the bottom is usually of clay, muddy sand or pure mud rather than the hard tops of the banks and inshore ground. In summer, they usually move up onto the soft mud and in winter move down into the deeper gullies. Witch flounder have been caught in a bottom temperature range of -1 °C to 11 °C. However, evidence from scientific investigations indicates that they are most abundant within a bottom temperature range of 2 °C to 6 °C.

Witch flounder are associated with deep holes and channels between the coastal banks and along the deep edges of the banks where water temperatures are usually in a range suitable for their habitation. These localized areas of high abundance are habitually more prominent in the winter-spring time when this species forms dense pre-spawning concentrations.

The species is found throughout the Gulf of St. Lawrence, usually in the deeper waters of the Laurentian and Esquiman Channels. In winter, a dense concentration may be found in the channel southwest of St. George's Bay. In summer, they are plentiful on the smooth muddy bottom on the southwest side of St. George's Bay. In the southern Gulf of St. Lawrence, they assemble in the area northeast of Prince Edward Island and just west of Cape Breton Island.

Witch flounder are a rather sedentary species and do not appear to undertake long-distance migrations. They concentrate in selected water suitable for spawning, then disperse in the surrounding areas for feeding. Young witch flounder are either pelagic (midwater) or they live in very deepwater areas where the only probable threat to them is the redfish fishery. The very rough grounds and great depths where many occur are particularly efficient safeguards against exploitation by existing trawling capabilities.

The deepwater phase of the very young also reduces direct competition for food from such groundfish species as the Atlantic cod and the American plaice.

Although detailed information on spawning of witch flounder in the Gulf of St. Lawrence is sparse, it is known that in January-February they form a large pre-spawning concentration in the Laurentian Channel just southwest of St. George's Bay. Preliminary observations on the stages of maturity of these fish in January would suggest that peak spawning in this area may take place in late spring or early summer.

### **American Plaice**

The distribution of American plaice (*Hippoglossoides platessoides*) is widespread throughout the area and is probably the most abundant flatfish in the Northwest Atlantic. While American plaice is considered to be a cold water species, it appears to have a fairly wide temperature tolerance. It occurs in temperatures ranging from about -1.5°C to temperatures above 5°C and from inshore localities down to 700 m. However, the preferred temperature for this species appears to be in the range from just below 0°C to about 1.5°C and principally in the 90 to 250 m depth range. As a rule, plaice encountered in the deeper ranges are at higher temperatures. It is worth noting that the largest catches are normally taken between 125 and 200 m in temperatures of -0.5° to 1.0°C.

Plaice produce large quantities of eggs. A 40 cm plaice, on the average, produces 250,000 to 300,000 eggs and a 65 to 70 cm plaice produces nearly 1,500,000 eggs. Spawning and fertilization of the eggs occur at or near the bottom and the fertilized buoyant eggs float to the surface layer where hatching occurs.

While no specific spawning grounds for this species have been recognized, certain localities offer environmental conditions such as bottom type, temperature and depth that are particularly favourable for spawning activity.

American plaice are spring spawners, with spawning occurring at least as early as the first part of April on the Flemish Cap, and on the southern half of the Grand Banks, to late May or early June off Labrador.

The length of time between fertilization and hatching of the eggs varies considerably depending on the water temperature in the upper layers. Hence, developing eggs and larvae could drift a considerable distance before the young fish finally settle to the bottom.



## **Wolffishes**

The wolffishes are native to cold waters of the northern Atlantic and Pacific Oceans. They are bottom-feeders, eating hard-shelled invertebrates such as clams, echinoderms and crustaceans, which they crush with strong canine and molar teeth.

Two wolffish species, spotted (*Anarhichas minor*) and northern (*Anarhichas denticulatus*) are presently listed as threatened on Schedule 1 of SARA. The Atlantic or striped wolffish (*Anarhichas lupus*) is listed as a species of special concern on Schedule 1 of SARA. Species at risk are described in more detail in Section 5.2.7.

The spotted wolffish typically occurs at depths of 475 m or more. Tagging studies have shown that spotted wolffish only migrate locally, and do not form schools. According to Kulka *et al.* (2003), spatial analysis of DFO research vessel catch data from the Grand Banks indicated that spotted wolffish abundance declined from the late 1980s to the mid-1990s, with an increase in abundance during both survey seasons since the mid-1990s.

The northern wolffish have been found at depths of 600 m, but typically occurs at intermediate depths of 90 to 200 m. Tagging studies have shown that northern wolffish do not form large schools and do not migrate long distances.

Atlantic or striped wolffish is typically found further south than either northern or spotted wolffish. It has been found at depths of up to 350 m (Scott and Scott 1988). There is no evidence that Atlantic wolffish migrate long distances, or form schools in Newfoundland waters (DFO 2004b).

Although it is probable given the limited migration of the species, it is not known with certainty if any of these three wolffish species spawn in the Project Area. According to LGL Limited *et al.* (2005), fishers consulted for this SEA in July 2005 reported that bycatch for all three wolffish species remained high at certain locations within the Project Area.

### **5.2.4.2 Pelagic Species**

Pelagic fish are those species that spend the majority of their lives at the surface or in the water column off the seafloor. Within this broad life history classification, there exists three sub-divisions: the epipelagic fishes that live from coastal to oceanic waters, but only within the upper 100 m layer of water; the mesopelagic fishes that live between the euphotic zone and approximately 1,000 m; and the bathypelagic species that live in the water column below 1,000 m. The latter subgroup does not occur in the Project or

Affected Area as the depth maximum is about 350 m. Most of the commercial fish are epipelagic. Most epipelagic species are migratory and present in the Gulf of St. Lawrence typically during the summer and fall. Commercial pelagic species found the Project Area include: mackerel (*Scomber scombrus*), Atlantic herring (*Clupea harengus*); Atlantic salmon (*Salmo salar*), capelin (*Mallotus villosus*), shortfin mako shark (*Isurus oxyrinchus*) and porbeagle shark (*Lamna nasus*).

### **Mackerel**

The Atlantic mackerel (*Scomber scombrus*), a pelagic fish, is an active and migratory fish that is common to temperate waters of the open sea. Atlantic mackerel winter outside of the Gulf of St. Lawrence but migrate to the Gulf of St. Lawrence in spring to spawn in the Magdalen Shallows (outside of the Project Area). Spawning typically occurs between mid-June and mid-July in open water, resulting in a concentration of fertilized eggs in the upper 10 m of the water column. Larval hatching generally occurs within five to seven days at water temperatures of 11 to 14°C (Scott and Scott 1988).

### **Herring**

Atlantic herring (*Clupea harengus harengus*) is primarily a pelagic fish and often schools, particularly just prior to spawning. Along the Canadian coast, Atlantic herring may spawn in any month between April and October, but spawning is concentrated in May (spring spawners) and September (fall spawners) (Ahrens 1993). Important spring (May to June) herring spawning grounds exist in 4Ra and 4Rd, and fall spawning in 4Ra from mid-July to mid-September.

Atlantic herring are demersal spawners depositing their adhesive eggs on stable bottom substrates (Scott and Scott 1988; Reid *et al.* 1999). Spawning may occur in offshore waters (*e.g.*, Georges Bank) at depths of 40 to 80 m; however, most Atlantic herring stocks spawn in shallow (<20 m) coastal waters, and it appears that in the Newfoundland region Atlantic herring spawn in coastal waters only. Spring spawning generally takes place in shallower waters than fall spawning in coastal areas. In coastal waters in the Gulf of St. Lawrence, spring spawning largely takes place in waters four to six metres deep while fall spawning takes place at depths of 18 to 22 metres (Tibbo *et al.* 1963). Tibbo (1956) adds that the heads of the various bays and deepwater inlets around insular Newfoundland are the main spawning areas. In a review of Atlantic herring spawning grounds in the Northwest Atlantic, Reid *et al.* (1999) reported that spawning on stable substrates in shallow waters close to shore insures that the eggs will be exposed to well-mixed water, and tidal currents averaging 0.75 to 1.5 m/sec have been recorded in the area of Atlantic herring spawning beds. Reid *et al.* (1999) state these high-energy environments provide aeration, and reduce siltation and accumulation of metabolites.

Recently hatched Atlantic herring larvae are pelagic. The duration of the larval stage of fall spawned herring is more extensive (*i.e.*, lasts through the winter months) than spring spawned herring. Some larvae are retained in tidally energetic areas near the spawning site for several months after hatching, while other larvae are dispersed soon after hatching and drift with residual currents.

Important feeding areas for herring occur in St. George's Bay, south of the Project Area in the spring, in southern 4Ra in the summer and in north 4Ra in the fall and excludes 4Rb and 4Rc (DFO 2004c). Herring overwinter in Esquiman Channel.

### **Atlantic Salmon**

While the commercial fishery for Atlantic salmon (*Salmo salar*) is under moratorium, this species remains an important recreational fishery species in Newfoundland and Labrador. This anadromous fish could potentially be impacted by oil and gas activities during their migrations as it migrates between both freshwater (spawning) and marine habitats (feeding, growth).

The Atlantic salmon management areas or salmon fishing areas (SFAs) in the Project Area is SFA 14A - Cape St. Gregory to Cape Bauld (DFO 2003). These SFAs are important large salmon components as they contain a mixture of maiden fish (never spawned before) which have spent two or more years at sea, and repeat spawners which are returning to the rivers for a second or subsequent spawning.

Conservation requirements for Atlantic salmon spawning rivers are considered to be threshold reference points. The status of salmon stocks is assessed based on the proportion of egg deposition achieved in a given year and trends in abundance of various life stages. These requirements are established for individual rivers in Newfoundland, including the following ones that occur within the Project Area: Torrent River (4Rb) and Lomond River (4Rb).

There was no significant increase in adult salmon recruitment, in SFA 14A in 2003, but conservation requirements were exceeded.

### **Capelin**

Capelin is one of the most important forage fishes for the marine ecosystem. Capelin (*Mallotus villosus*) overwinter in offshore waters, move shoreward in early spring to spawn on beaches throughout the region in the spring-summer, typically in May to July on the west coast of Newfoundland, over a wide range of temperatures from 2.5 °C to

10.8 °C (Frank and Leggett 1981), and return to offshore waters in autumn. Spawning lasts about four to six weeks (DFO 2005b).

Beach spawning is demersal with the eggs being deposited in the intertidal zone. Occurrence of egg masses indicate that subtidal spawning takes place at depths ranging from approximately 1 to 37 m and up to approximately 400 m from shore in years and areas where water temperatures on the beaches exceeds the preferred spawning temperatures (Templeman 1948). Subtidal spawning is assumed to be variable from year-to-year.

### **Shortfin Mako Shark**

Shortfin mako sharks live in tropical and temperate offshore waters. They are a pelagic species that occur from the surface down to depths of 150 metres. This shark is seldom found in waters colder than 16 °C. The shortfin mako is found worldwide. In the western Atlantic it can be found from Argentina and the Gulf of Mexico to Browns Bank off of Nova Scotia. In Canadian waters these sharks are not abundant as they prefer warm waters, but neither are they rare. Shortfin makos are often found in the same waters as swordfish as they are a source of food and both fish prefer similar environmental conditions. Female shortfin makos usually become sexually mature at a length of three metres. Developing embryos feed on unfertilized eggs in the uterus during the gestation period of 15 to 18 months. The 4 to 18 surviving young are born live in the late winter and early spring at a length of about 70 cm, but have no placental connection during development (ovoviviparity). It is believed that females may rest for 18 months after birth before the next batch of eggs are fertilized. This status of this species is pending public consultation for addition to Schedule 1 of SARA. It was categorized as threatened in April 2006.

### **Porbeagle Shark**

The porbeagle shark is common in pelagic and littoral zones, and inhabits water down to a depth of 370 metres. It is most commonly found on continental shelves or inshore. It prefers cool waters and is usually found in temperatures below 14 °C. Porbeagles occur on both sides of the Atlantic, and in the south Pacific and Indian Oceans. In the western North Atlantic it can be found from Raleigh, Newfoundland at its northernmost range to the Gulf of St. Lawrence, the Scotian Shelf, the Bay of Fundy and the Gulf of Maine to New Jersey and perhaps to South Carolina. Off Nova Scotia the porbeagle is generally found in waters less than 14 °C. The porbeagle is ovoviviparous, retaining the developing young within the brood chamber before giving birth to live young. The developing sharks obtain nutrients by devouring other fertilized eggs in the oviduct. Young are probably born in the late winter and spring. The females generally produce four pups that are between 60 to 75 cm long at birth. Female porbeagles reach sexual

maturity at an age of 12 years or older, while the males are mature at age seven. COSEWIC has categorized this species as endangered since May 2004. The species has no designation with SARA.

### 5.2.4.3 Shellfish

Shellfish is a broad term for all aquatic animals that have a shell of some kind. Shellfish are separated into two basic categories—crustaceans and mollusks. Crustaceans include crabs, crayfish, lobster and shrimp. Mollusks are divided into three groups—gastropods (also called univalves) such as the whelks and periwinkles, bivalves like the scallop and mussel, and cephalopods like octopus and squid. The commercially sought after echinoderms such as sea urchins and sea cucumbers are not considered.

A comprehensive nearshore list of mollusks are described in the Project Area by Dunbar *et al.* (1980). Typical bivalve and gastropod species include both Icelandic (*Chlamys islandicus*) and sea scallops (*Placopecten magellanicus*), red horse mussels (*Modiolus modiolus*), blue mussels (*Mytilus edulis*), arctic glassy mussels (*Dacrydium vitreum*), quahogs (*Arctica islandica* and *Mercenaria mercenaria*), jingle shells (*Yoldia spp.*), nutclams (*Nucula spp.s*), wavy astarte (*Astarte undata*), sunset northern dwarf telling (*Tellina agilis*), cockles (*Serripes groenlandicus*, *Clinocardium ciliatum*, and *Cerastoderma pinnulatum*), borrowing clams (*Mesodesma arctatum*, *Hiatella arctica*, *Xylophaga abyssorum*), naval shipworm, limpets, chitons, periwinkles (*Littorina spp*), moonsnails (*Polinices spp.*), whelks (*Buccinum* and *Neptunea*) and winkles (*Nassarius spp.*).

Of the large decapods, five crab species and lobster occur in the Affected Area. Crabs species include hermit crabs (*Pagurus acadianus* and *P. pubescens*), toad crabs (*Hyas coarcticus* and *H. araneus*), rock crab (*Cancer irroratus*) and snow crab (*Chionecetes opilio*). With except of the hermit crabs, all are commercial species to varying degrees in Atlantic Canada.

#### **Short-finned Squid**

Squids represent a major fishery resource widely distributed throughout the oceans of the world. Of the several hundred species harvested around the world, only the short-finned squid (*Illex illecebrosus*) has been of major commercial importance to the fishery in Atlantic Canada. This species is common throughout areas of the Maritimes and Newfoundland. The long-finned squid (*Loligo pealii*) also occurs, but only in very low abundance, in Atlantic Canadian waters.

The short-finned squid ranges from Greenland to Florida, with fishable concentrations found from the Gulf of St. Lawrence and Newfoundland to Cape Hatteras. Abundance

and distribution vary greatly, both seasonally and annually. Through July, August and September, the distribution extends to cover large areas of the Continental Shelf and, some years, to the Gulf of St. Lawrence.

Distribution in both the offshore and inshore areas is believed to be strongly influenced by environmental conditions, with water temperature being a major factor. Evidence suggests that highest concentrations occur where bottom temperatures exceed 6 °C. There seems little doubt that temperature at intermediate depths as well as other biological factors such as predator and prey abundance and their distribution also play an important role.

Abundance peaks in September, then drop dramatically in October and November as the larger, maturing squids start to leave the shelf. During autumn, the distribution area recedes to about that of early summer.

It is believed that the adults migrate to a spawning area near Cape Hatteras or even further south over the Blake Plateau off southeastern United States. It was not until 1979 that a joint Canadian/Soviet research team found some larvae and large numbers of juveniles extending hundreds of kilometres between the Scotian Shelf edge and the frontal zone of the Gulf Stream. In late spring and summer, these juvenile squid complete the cycle by migrating shoreward and onto the Continental Shelf.

Squid spend the daylight hours near the bottom of the ocean, seeming to prefer areas where the bottom temperature is 6 to 7°C or greater. At night they tend to disperse upward, a behaviour characteristic which is vital to squid jigging in offshore areas. Generally, a vessel will locate its fishing area, start jigging in the early evening and continue through to early morning.

### **Northern Shrimp**

Eleven species of decapod shrimp are distributed in the Project Area (Dunbar *et al.* 1980). Of these species the northern (or pink) shrimp (*Pandalus borealis*) occupies the most area in the Gulf of St. Lawrence and supports an important commercial fishery. Northern shrimp breed in the fall and the females carry the fertilized eggs for approximately eight months (September to April) and release their larvae in April and May. Larvae are pelagic upon hatching in the spring but eventually settle to the bottom by late summer (July to September). Shrimp migrations tend to be associated with breeding (berried females move into shallower waters in winter) and feeding (upward movement in water column at night to get to plankton). Northern shrimp are generally found in areas with water depths ranging between 150 and 350 m (DFO 2004c).

## **Snow Crab**

Snow crab, also referred to as Queen crab, are found throughout the Northeast Atlantic from Greenland to the Gulf of Maine, preferring deep, cold-water conditions. Snow crabs are the most important species of crab harvested in Atlantic Canada. Major fishing areas for snow crab include the eastern shores of Newfoundland-Labrador as well as the Gulf of St. Lawrence, an area shared by fishers from all the Atlantic provinces and Quebec ([http://www.dfo-mpo.gc.ca/media/backgrou/2003/snowcrab\\_e.htm](http://www.dfo-mpo.gc.ca/media/backgrou/2003/snowcrab_e.htm)).

Snow crab occurs over a broad depth range (50 to 1,300 m) in the Northwest Atlantic. The distribution of this decapod in waters off Newfoundland and southern Labrador is widespread but the stock structure remains unclear (LGL Limited *et al.* 2005). Snow crabs have a tendency to prefer water temperatures ranging between -1.0 and 4.0 °C (DFO 2005c). Large snow crabs ( $\geq 95$ -mm carapace width or CW) occur primarily on soft bottoms (mud or mud-sand) (DFO 2005c), particularly in water depths of 200 to 500 m. Small snow crabs appear to be most common on relatively hard substrates (DFO 2005c).

It is believed that snow crab live for five to six years after their final molt, with a maximum lifespan of about 12-13 years. Both male and female crabs cease to molt when they reach sexual maturity. Female shells rarely reach widths of 9.5 centimetres and a fully grown male crab is approximately twice as large, reaching a maximum shell width of 14 centimetres.

## **Lobster**

Lobsters (*Homarus americanus*) are distributed nearshore around the entire island of Newfoundland. Lobster are most commonly taken in shallow water depth <40 m, but they can occur down to 400 m. Lobsters can undertake extensive migrations in the winter, some tagged animals traveled 200 km offshore.

The major lobster life history events (*i.e.*, molting, spawning, larval hatching) typically occur between mid-summer and early fall, following the spring fishery (DFO 2003). Eggs carried by the female hatch in summer. The planktonic larvae remain in the neuston for one to two months before descending to become benthic. These juvenile lobsters seek substrates with refuge, such as cobble and boulder bottoms or other suitable substrates. Adult occupy a variety of habitats, in offshore waters where there maybe an absence of cover, they will dig depressions.

During SEA consultations with fishermen in July 2005 (LGL Limited *et al.* 2005), fisherman noted lobster nursery areas near Shoal Point, Outer Bay of Islands located just above North Head (LFA 13B; EL 1097), and at an area further north known as Trout

River Bay (LFA 14A; EA 1098). These two areas are presently closed to the lobster fishery as a means of conservation. The areas are defined as follow:

Corner coordinates of area in LFA 13B/ EL 1097

49° 19' 25" N, 58° 14' 23" W

49° 19' 35" N, 58° 14' 45" W

49° 20' 10" N, 58° 14' 25" W

49° 20' 00" N, 58° 14' 05" W

Headland to headland coordinates of area in LFA 14A/EL 1098

49° 29' 30" N, 58° 07' 12" W

49° 28' 56" N, 58° 07' 24" W

### 5.2.5 Marine Mammals

Marine mammals species present in the Gulf of St. Lawrence belong to the order Cetacea (dolphins, porpoises and whales) and the order Pinnipedia (seals and walruses). This report is not considering marine mammal members of the mustelids (otters, minks, *etc.*) nor polar bears (*Ursus maritimus*). Thirteen species of cetacean and four species of pinniped regularly occur in western Newfoundland waters. Table 5.3 provides the habitat occurrence on marine mammals in the Project Area. Information on distribution, species habitats, feeding, breeding and migratory characteristics of marine mammals are summarized from Lesage *et al.* (2007). Their paper provides the most comprehensive review of existing literature on marine mammals in the Gulf of St. Lawrence as well as presentation of recent aerial survey data on distributions. Their abundance in the Gulf likely results from the combination of abundant food resources, sheltered haul-out areas and stable ice.

Quantitative data to describe their seasonal abundance and distribution are generally scarce, particularly for cetaceans. Data concerning the two marine mammal groups also differ markedly in type, details and areas covered.



**Table 5.3 Marine Mammals Occurring in the Gulf of St. Lawrence**

Species	Distribution in Affected Area (Western NFLD)	Life History in Affected Area	Abundance	Migration
Fin whale	Common, ice-free period Vacates GoSL in winter but some recorded ice entrapment SW shore March and April	Feeding	4000 to 8000 in NL low 100s in GoSL	North-south seasonal Calving or breeding ground unknown
Humpback whale	Regular but not common, ice-free period Winter occurrence undocumented	Feeding	2,500 Canadian waters, unknown in GoSL	Between temperate to high latitude summer feeding grounds and low latitude breeding grounds
Minke whale	Common Winter data lacking	Feeding	4,000 Canadian waters, 1,000+ in GoSL, no reliable estimate	Between northern feeding grounds and southern calving grounds
Blue whale	Mostly ice -free period, Possibly year round noted by ice-entrapment in southwest Newfoundland' St. Georges Bay and Esquiman Channel	Feeding	No estimates in northwest Atlantic, possible a few 100; GoSL 50 to 105 individuals per year	Coastal and offshore waters from high latitude during feeding season
North Atlantic right whale	Historically were present, Observed Sept-Iles/Mingan Is., Gaspé, Cabot Strait and western Newfoundland. May be regular but in low numbers	Feeding GoSL possible summering habitat with calves	300 in North Atlantic	North-south seasonal between high latitude feeding grounds and southern latitude calving and wintering grounds
Beluga whale	Unusual occurrences in summer and fall periods of lone juveniles	Unknown	1000 to 1200	Saguenay to St. Lawrence Estuary
Killer whale	Northwest Gulf, sporadic in Strait of Belle Isle Occasional western shelf of Newfoundland and St. Georges Bay		No estimates for northwest Atlantic, 64 in Newfoundland and Labrador	Not documented
Long-finned pilot whale	Common No winter information		Possibly a few 1000	No north-south seasonal migration Some seasonal inshore-offshore migration
Northern bottlenose whale	Uncommon		No estimates for Labrador/Davis Strait	

**Table 5.3 Marine Mammals Occurring in the Gulf of St. Lawrence**

Species	Distribution in Affected Area (Western NFLD)	Life History in Affected Area	Abundance	Migration
			population	
Sperm whale	Unusual, during ice-free period	Feeding, Most likely only males	No reliable estimates, few 1000 in western North Atlantic	Females and calves range small, males migrate between northern latitudes and tropical/subtropical mating grounds
Harbour porpoise	Common, ice-free period	Summering	36,000 to 125,000	Poorly understood
Atlantic white-sided dolphin	Regular but sporadic, ice-free period		No reliable estimates, 500 to 12,000 GoSL	Unknown
Shortbeaked common dolphin	Occasionally		243 individuals from one survey	unknown
Whitebeaked dolphin	Uncommon, northern Gulf, Strait of Belle Isle		2,500 in 1995 and 1996	Not understood
Harbour seal	Coastal, year round Not common in western Newfoundland, likely during ice-free period.	Historical data indicates St. George's Bay as a whelping area	4,000 - 5,000 in GoSL	Sedentary, with some adults taking long migrations
Harp seal	December to May leave the Gulf in May	Feed in November and December Ice whelpers,	2,000,000 in GoSL	Migratory and pelagic, summers high Arctic and winters off Newfoundland and Labrador coasts, and GoSL
Hooded seal	Enter GoSL in fall and remain until early May, a few through the Strait of Belle Isle	Ice whelpers in March		Migratory and pelagic, summers in Arctic and winters in eastern Canada
Grey seal	Coastal, year round, Uncommon on western shelf of Newfoundland		52,000 in GoSL	Seasonal within the GoSL for moult, feeding and breeding

### 5.2.5.1 Pinnipeds

The four most common species in the Estuary and Gulf of St. Lawrence are the harp (*Pagophilus groenlandicus*), hooded (*Cystophora cristata*), grey (*Halichoerus grypus*) and harbour (*Phoca vitulina concolor*) seals. Harp and hooded seals are seasonal visitors to the Affected Area, as they move into the Gulf and Estuary in December to January, with most individuals leaving the area in April to May (Hammill 1993; Mansfield 1967b; Sergeant 1976; Sergeant 1982b; Sergeant 1991). Grey seals are primarily summer residents to the area, but some animals occupy the Gulf region year round (Austin *et al.* 2004; Goulet *et al.* 2001; Harvey 2007; Lavigne and Hammill 1993; Mansfield and Beck 1977; Robillard *et al.* 2005; Stobo *et al.* 1990). Harbour seal colonies are found in several areas of the Estuary and Gulf of St. Lawrence and reside there throughout the year (Boulva and McLaren 1979; Lesage *et al.* 2004; Robillard *et al.* 2005). None of these seal species are listed under COSEWIC or SARA.

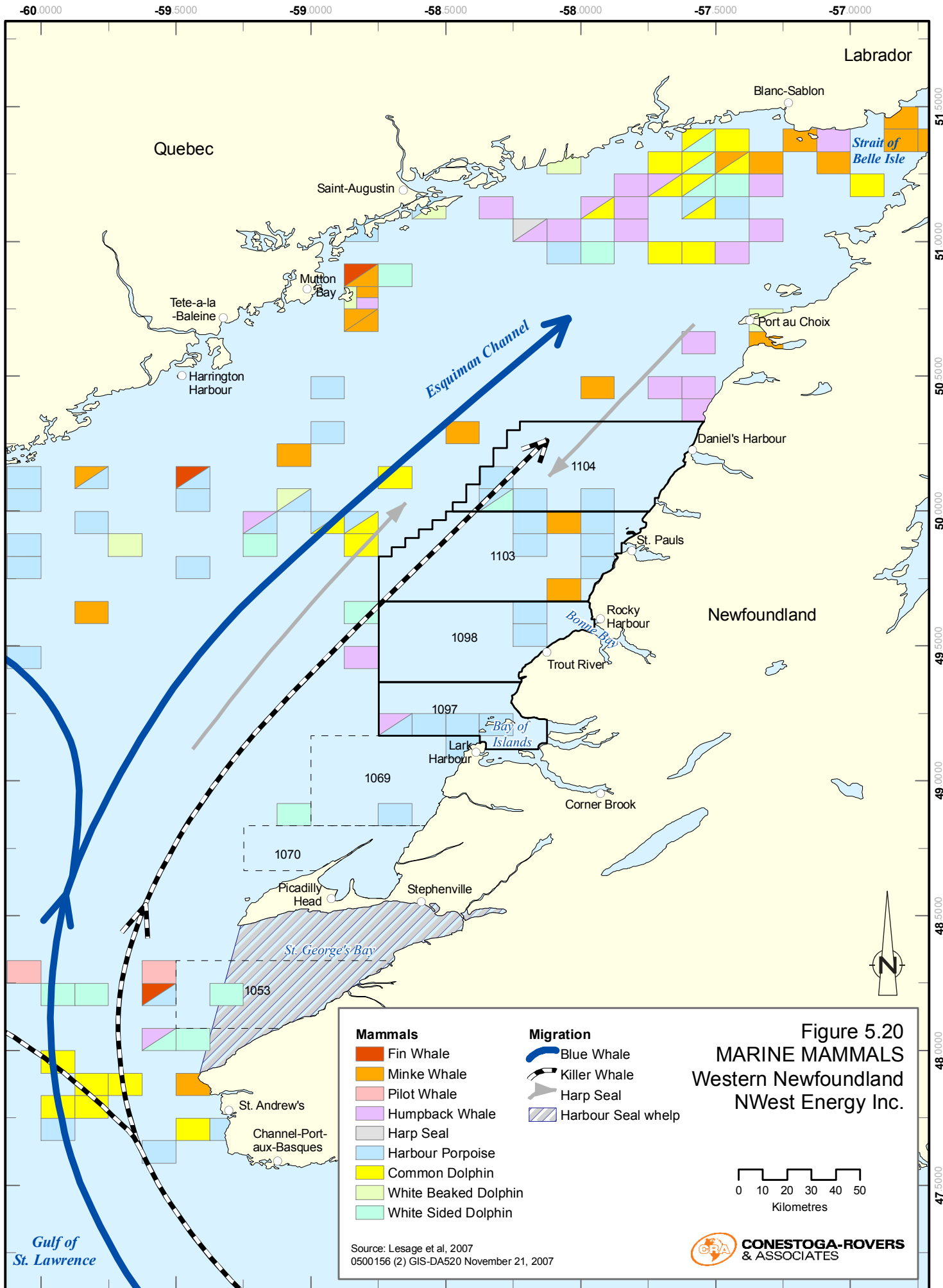
Occasional sightings of walrus are still reported from the southern Gulf of St. Lawrence, but these are likely vagrant animals, as the last walrus was exterminated from the Îles-de-la-Madeleine in the 1700s (Kingsely 1998b).

### 5.2.5.2 Cetaceans

The Lesage *et al.* (2007) survey noted that five species of whales were observed in late-July to mid-September along the western shelf of Newfoundland or at the head of Esquiman Channel. The species were dominated by fish-eating toothed cetaceans, harbour porpoise and white-sided dolphin, and harp seals, and some opportunistic feeding baleen whales, humpback and minke whales. Pilot, fin and sperm and blue whales are also noted in other surveys, both systematic and opportunistic. Figure 5.20 show the cetacean census as compiled from three aerial surveys.

The area is used by nine different species during the ice-free period. The aggregation of deep-dwelling zooplankton at the head of Esquiman Channel may serve as an important feeding area.

Fin whales are considered as a species of special concern by COSEWIC. Humpback whales are not at risk (COSEWIC 2003). The status of the minke whale has not been evaluated by COSEWIC, but their populations are generally considered to be much healthier than those of the other baleen whales. The blue whale is listed as endangered by COSEWIC (Sears and Calambokidis 2002) and by SARA. The North Atlantic right whale (*Eubalaena glacialis*) is the most endangered large whale in the world and is listed under Schedule 1 of SARA as endangered (Government of Canada 2005).



## 5.2.6 Marine Turtles

Three species of sea turtle could potentially occur in the Western Newfoundland and Labrador Offshore Area including the leatherback turtle (*Dermochelys coriacea*), the loggerhead turtle (*Caretta caretta*), the Kemp's ridley turtle (*Lepidochelys kempii*). Both loggerheads and leatherbacks are common in the waters off Newfoundland during the summer and fall (Goff and Lien 1988; Marquez 1990; Witzell 1999). Little is known about the distribution of Kemp's ridley turtles in eastern Canada, although they are thought to be rare (Breeze *et al.* 2002). Adults of this species are rarely found beyond the Gulf of Mexico; however, juvenile animals range as far north as Newfoundland (Ernst *et al.* 1994).

### **Leatherback Turtle**

Leatherbacks can be found in the tropical, temperate and boreal waters of the Atlantic, Pacific and Indian Oceans. They are also found in the Mediterranean Sea. The northernmost recorded latitude of a leatherback is 71°N and the southernmost is approximately 27°S. In Canada, the leatherback turtle can be found off the coasts of British Columbia, Nova Scotia, Newfoundland and Labrador, New Brunswick and Prince Edward Island. There have also been records of turtles off Baffin Island and near Quebec in the Gulf of St. Lawrence. Satellite telemetry studies are underway to gain an understanding of their migrations. The worldwide population of leatherbacks turtles (*Dermochelys coriacea*) was censused at between 26,000 and 43,000 (Dutton *et al.* 1999). There are no estimates of the population size in Canada; however, adult leatherbacks are thought to be a regular part of the Newfoundland marine fauna in the summer and fall (Goff and Lien 1988; Witzell 1999) during their northerly excursions to feed on jellyfish. The leatherback turtle is listed under Schedule 1 of SARA as endangered. Although there are no estimates available for the number of leatherback turtles in the western Newfoundland offshore region, they are potentially a regular part of the marine fauna in the Affected Area.

### **Loggerhead Turtle**

The loggerhead turtle (*Caretta caretta*) are not observed as frequently as leatherbacks on the Scotian Shelf (Breeze *et al.* 2002) and there are no estimates available for the density of loggerhead turtles in the western Newfoundland offshore region and are therefore likely to be rare in the Affected Area. The North American population, which is thought to be declining, has been estimated to number between 9,000 and 50,000 adults (Ernst *et al.* 1994). This species is classified as threatened under the U.S. *Endangered Species Act* (ESA).

### **Kemp's Ridley Turtle**

Adult Kemp's ridley turtles (*Lepidochelys kempii*) rarely range beyond the Gulf of Mexico, but juveniles can be found as far north as Newfoundland on the east coast of North America (Ernst *et al.* 1994). There are no estimates on the number of Kemp's ridley turtles occurring in Canadian waters. The number of Kemp's ridleys that visit the western Newfoundland offshore region is unknown, but this species is likely to be extremely rare in the Affected Area. Kemp's ridley turtles are considered endangered under the U.S. ESA.

## **5.2.7 Species at Risk**

### **Marine Birds**

Harlequin Duck (*Histrionicus histrionicus*) are the only bird species-at-risk in the Affected Area. The eastern population of the Harlequin Duck is presently listed as a species of concern on Schedule 1 of SARA and designated vulnerable by the Government of Newfoundland and Labrador. It breeds along streams and rivers draining the Long Range Mountains. It may be found in coastal waters during both spring and fall staging at the mouths of nesting streams occurring in the Affected Area. A small late summer – fall moulting concentration occurs at Stearing Island of the coast of Gros Morne National Park (LGL Limited *et al.* 2005). Typically, these ducks overwinter in the ocean, but as the Gulf of St. Lawrence freezes, the ducks fly to the east coast.

Common and Arctic Terns occur on two offshore islands in Gros Morne National Park, Stearing Island and the White Rocks. Both species are designated sensitive by the Government of Newfoundland and Labrador.

The Ivory Gull is very vulnerable to any type of disturbance at certain times of the breeding season. They may abandon eggs if approached. The Ivory Gull breeds in high-Arctic coastal areas with permanent pack ice and open water. It winters primarily in Arctic seas, though may be seen along the Atlantic coast to New York (COSEWIC 2006d). There are no known nesting grounds for the Ivory Gull in the Affected Area, and any presence in the area are expected to be incidental.

### **Marine Fish**

Six fish species found in the Gulf of St. Lawrence with potential to be in the Project Area are considered to be 'at risk' according to COSEWIC and/or SARA. The northern wolffish, the spotted wolffish, shortfin mako, are listed as threatened. The Atlantic wolffish are listed as a species of special concern. The Atlantic cod (Newfoundland-Labrador population) and porbeagle shark are listed as endangered. The main reasons for designation are significant adverse population effects from direct or bycatch fishing

and habitat alteration (e.g., trawling). The International Union for Conservation of Nature (IUCN) also considers the following to be species at risk: Atlantic halibut, yellowtail flounder, and haddock. Table 5.4 contains a summary of species at risk (recognized under SARA or by COSEWIC) that may occur in the Regional Area.

**Table 5.4 Fish Species of Special Status Known to Occur in the Gulf of St. Lawrence**

Species	Status	Reason for Designation (COSEWIC)
Atlantic cod ( <i>Gadus morhua</i> ) Newfoundland and Labrador	SARA - Endangered (May 2003)  COSEWIC - Endangered (May 2003)	Cod in the inshore and offshore waters of Labrador and northeastern Newfoundland, including Grand Bank, having declined 97% since the early 1970s and more than 99% since the early 1960s, are now at historically low levels. There has been virtually no recovery of either the abundance or age structure of cod in offshore waters since the moratoria imposed in 1992 and 1993.  Threats to persistence include fishing (now halted), predation by fish and seals, and natural and fishing-induced changes to the ecosystem.
Spotted wolffish ( <i>Anarhichas minor</i> )	SARA - Threatened, on Schedule 1 (2002)	Since 1978, scientific surveys in the western Atlantic indicate a 96% decline in the Canadian population of Spotted Wolffish over 21 years (equivalent to 3 generations of wolffish). The species is also found in significantly fewer survey stations.  In Canada, it occurs primarily off northeast Newfoundland. Scientific surveys from all parts of the western Atlantic range indicate declines in the abundance of Northern Wolffish over the past 20 years. From 1978 to 1994, abundance in the primary range off northeast Newfoundland declined by 98%. The number of locations where the species occurs has also declined.  Threats include mortality as by-catch and habitat alteration by bottom trawling. Dispersal is limited.
Northern wolffish ( <i>Anarhichas denticulatus</i> )	COSEWIC - Threatened (May 2001)	
Atlantic wolffish ( <i>Anarhichas lupus</i> )	SARA - Special Concern, on Schedule 1 (2002)  COSEWIC - Species of Special Concern (Nov 2000)	Available data indicate that the number of Atlantic Wolffish in Canadian waters has declined by 87% from the late 1970's to the mid 1990's. The number of locations where the species occurs has declined and the range where the species is abundant may be shrinking. Even though it has declined significantly, it is thought to be very widespread and to still exist in relatively large numbers.

**Table 5.4 Fish Species of Special Status Known to Occur in the Gulf of St. Lawrence**

Species	Status	Reason for Designation (COSEWIC)
Shortfin Mako <i>(Isurus oxyrinchus)</i>  Atlantic Population	SARA - Threatened (Apr 2006)  COSEWIC - Threatened (Apr 2006)	<p>As a large (maximum length 4.2 m), relatively late-maturing (7-8 yrs) pelagic shark, the species has life-history characteristics making it particularly susceptible to increased mortality from all sources, including human activities. The species is circumglobal in temperate and tropical waters. Individuals found in Atlantic Canada are considered part of a larger North Atlantic population. There does not appear to be any reason to assume that the Canadian Atlantic "population" is demographically or genetically independent from the larger Atlantic population, so the status of the species in Atlantic Canada should reflect the status throughout the North Atlantic. Although there is no decline in an indicator of status for the portion of the species that is in Atlantic Canada, two analyses suggest recent declines in the North Atlantic as a whole (40% 1986-2001; 50% 1971-2003).</p> <p>The main causes of the species' decline (mortality due to bycatch in longline and other fisheries) are understood and potentially reversible, but these sources of mortality have not been adequately reduced.</p>
Porbeagle shark <i>(Lamna nasus)</i>	SARA - Endangered (May 2004)  COSEWIC - Endangered (May 2004)	The abundance has declined greatly since Canada entered the fishery in the 1990s after an earlier collapse and partial recovery. Fishery quotas have been greatly reduced, and the fishery has been closed in some areas where mature sharks occur. The landings are now comprised mostly of juveniles. Its life history characteristics, including late maturity and low fecundity, render this species particularly vulnerable to overexploitation.
Winter skate <i>(Leucoraja ocelatta)</i>  Northern Gulf- Newfoundland	SARA - No status  COSEWIC - Data deficient (May 2005)	The species exists in low concentrations in the Northern Gulf of St. Lawrence, in the coastal waters off the southern coast of Newfoundland, and on the southern portion of the Grand Bank. A quantitative analysis of spatial and temporal variation in population size is not possible because of the infrequency with which the species is caught. The population is subjected to bycatch.

### Marine Mammals

Four species of marine mammals found in the Gulf of St. Lawrence with potential to be in the Regional Area are considered to be 'at risk' according to COSEWIC and/or SARA (Table 5.5).



**Table 5.5 Marine Mammals Species of Special Status that May Occur in the Affected Area**

Species	Status	Comments
<p>Blue whale (<i>Balaenoptera musculus</i>) (Atlantic Population)</p>	<p>SARA -Endangered, Schedule 1  COSEWIC- Endangered (May 2002)</p>	<p>During spring, summer, and fall, these whales occur along the north shore of the Gulf of St. Lawrence and off eastern Nova Scotia. In summer they also occur off the south coast of the island of Newfoundland and in the Davis Strait, between Baffin Island and Greenland. They usually migrate south for the winter, but in years of light ice cover, some whales may remain in the St. Lawrence for much of the winter. Between 20 and 105 blue whales are seen annually in the Gulf of St. Lawrence in photo identification studies. A total of 382 individuals have been catalogued in the Gulf since 1979. About 40% of these return regularly, while the remainder appear to be occasional visitors that typically range outside the Gulf of St. Lawrence.</p> <p>Whaling reduced the original population. There are fewer than 250 mature individuals and strong indications of a low calving rate and a low rate of recruitment to the studied population. Today, the biggest threats for this species come from ship strikes, disturbance from increasing whale watch activity, entanglement in fishing gear, and pollution. They may also be vulnerable to long-term changes in climate, which could affect the abundance of their prey (zooplankton).</p>
<p>Fin whale (<i>Balaenoptera physalus</i>) (Atlantic population)</p>	<p>SARA - Species of Special Concern, Schedule 1  COSEWIC- Species of Special Concern (May 2005)</p>	<p>The size of this population was reduced by whaling during much of the 20th Century. However, sightings remain relatively common off Atlantic Canada and they have not been hunted since 1971. The current abundance and level of depletion compared with pre-whaling numbers are uncertain. The whales face a number of current threats including ship strikes and entanglement in fishing gear, but none is believed to seriously threaten the population.</p>
<p>North Atlantic right whale (<i>Eubalaena glacialis</i>)</p>	<p>SARA - Endangered, Schedule 1 (2003)  COSEWIC- Endangered (May 2003)</p>	<p>The species, found only in the North Atlantic, was heavily reduced by whaling. The total population currently numbers about 322 animals (about 220-240 mature animals), has been decreasing during the last decade, and is experiencing high mortality from ship strikes and entanglement in fishing gear. A sophisticated demographic model gives an estimated mean time to extinction of 208 years.</p> <p>Critical areas for the North Atlantic right whale include the Roseway Basin and part of the Bay of Fundy.</p>

**Table 5.5 Marine Mammals Species of Special Status that May Occur in the Affected Area**

Species	Status	Comments
Harbour porpoise <i>(Phocoena phocoena)</i> (Northwest Atlantic population)	SARA – No status-pending public consultation COSEWIC – Species of Special Concern (Apr 2006)	The species is widely distributed in eastern Canadian marine waters. Surveys of portions of the range (Bay of Fundy/Gulf of Maine and the Gulf of St. Lawrence) during the late 1990s indicated more than 100,000 porpoises. Incidental catch (bycatch) in fishing gear, especially gillnets, is a major source of mortality. Bycatch probably has declined in areas where use of gillnets has decreased. Management measures in the Bay of Fundy and Gulf of Maine have been shown to reduce porpoise bycatch rates in gillnets. However, these measures have not been implemented in much of the species’ range, including the Gulf of St. Lawrence and Newfoundland and Labrador, where annual mortality in several gillnet fisheries is still estimated to be in the thousands. There is also some concern that porpoises in the Bay of Fundy and possibly other areas may be excluded from portions of their habitat by acoustic harassment devices associated with aquaculture. Although the population remains abundant, the particular susceptibility of harbour porpoises to bycatch in fishing gear represents an incipient threat. Given that, the lack of good abundance information in some parts of the range and the lack of porpoise bycatch monitoring and mitigation in many of the relevant fisheries are reasons for concern.

**5.2.8 Sensitive Areas**

Three sensitive areas are identified for lobsters and marine birds within the Affected Area (Figure 5.21). Lobster nursery areas important during the summer months are present at North Head and Trout River Bay. During SEA consultations with fishermen in July 2005 (LGL Limited *et al.* 2005), fisherman noted lobster nursery areas near Shoal Point, Outer Bay of Islands located just above North Head (LFA 13B; EL 1097), and at an area further north known as Trout River Bay (LFA 14A; EL 1098). These two areas are presently closed to the lobster fishery as a means of conservation. The areas are defined as follow:

Corner coordinates of area in LFA 13B

- 49° 19' 25" N, 58° 14' 23" W
- 49° 19' 35" N, 58° 14' 45" W
- 49° 20' 10" N, 58° 14' 25" W
- 49° 20' 00" N, 58° 14' 05" W

Headland to headland coordinates of area in LFA 14A

49° 29' 30" N, 58° 07' 12" W

49° 28' 56" N, 58° 07' 24" W

One coastal sites in the Affected Area, Gros Morne National Park (adjacent to EL 1103), has been identified with the IBA designation.

A cod spawning area, referred to as the Cape St. George Spawning Area, is located off Port au Port for northern Gulf cod stock (4RS and 3Pn) in April and May, this area is outside of the Activity Area. This area is closed to groundfish harvesting between April 1<sup>st</sup> and June 15<sup>th</sup> each year. The area coordinates are as follows:

48° 00' N, 59° 20' W

49° 10' N, 59° 20' W

49°10' N, 60° 00' W

48°00' N, 60° 00' W

Lesage *et al.* (2007) are working to identify ecologically and biologically significant area in the Gulf of St. Lawrence, relative to marine mammals. This is difficult at this stage as the information to date is biased by several factors: low survey effort, few systematic surveys, limited seasonality of surveys, short time window of surveys, and limited coverage of opportunistic surveys.

### 5.3 Other Ocean Users

#### 5.3.1 Commercial Fisheries

The Project Area falls within North Atlantic Fisheries Organisation (NAFO) Unit Area (UA) 4Rb and 4Rc, however, only 19% of the Project Area occurs in 4Rc. Catch data were obtained from DFO Newfoundland Region. Only data with a spatial frame of reference was used and erroneously plotted data (points on land) were discounted unless points were plotted near the coast. The nearshore data used represents 9,610 of 15,500 records from 2004 to 2007; all 284 available records from the inshore data were used from 2004 to 2007; and 461 of 487 available records for 2004 to 2007 were used for the midshore fishery data. This analysis does not include data that were not reported (*e.g.* lobster, recreational or bait fisheries).

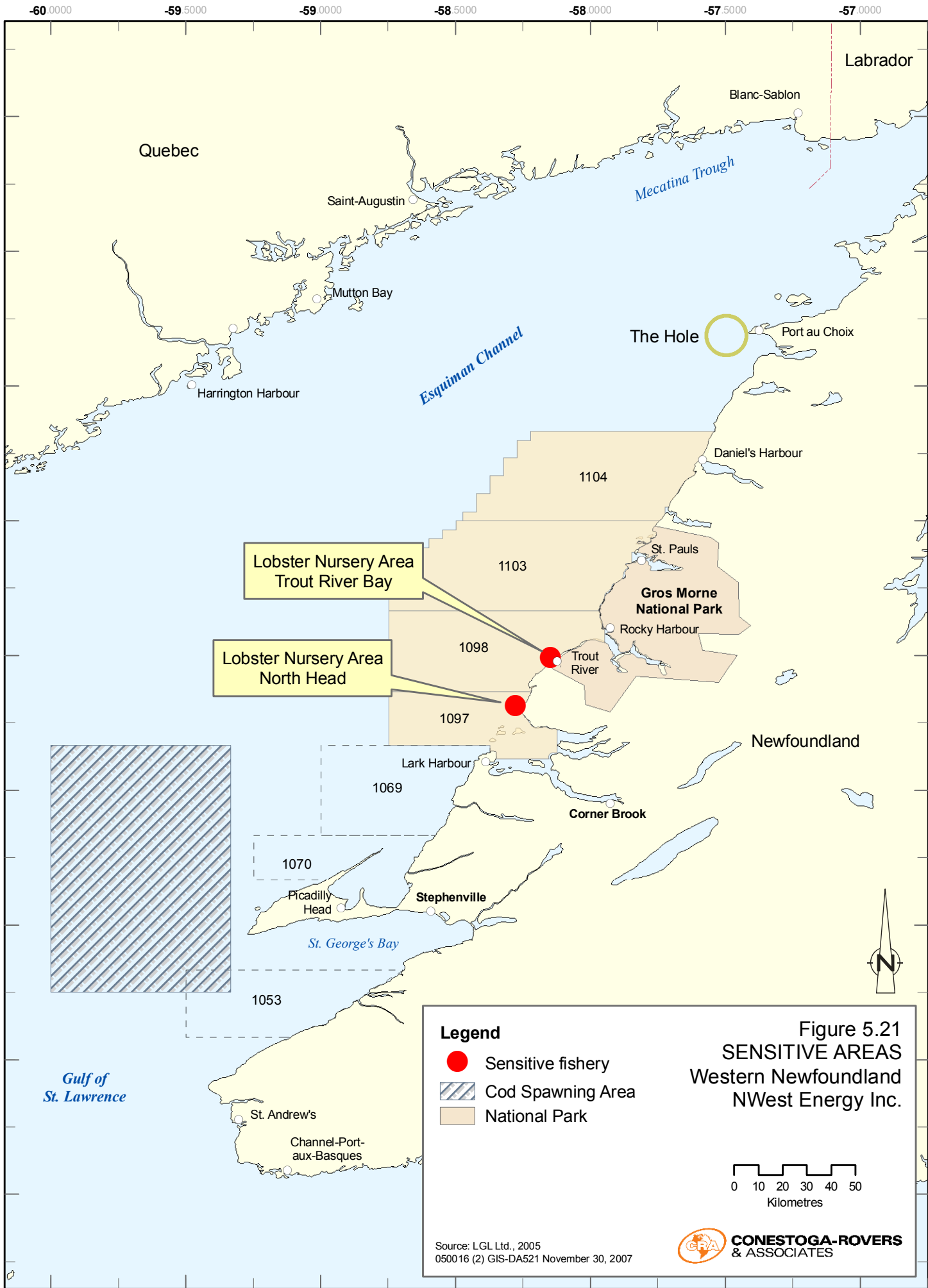


Figure 5.21  
**SENSITIVE AREAS**  
 Western Newfoundland  
 NWest Energy Inc.

- Legend**
- Sensitive fishery
  - Cod Spawning Area
  - National Park

0 10 20 30 40 50  
 Kilometres

Source: LGL Ltd., 2005  
 050016 (2) GIS-DA521 November 30, 2007

## **Historical Fisheries in NAFO 4R**

Historical fishing activities in 4R are described in the Western Newfoundland and Labrador Offshore Area Strategic Environmental Assessment (LGL Limited *et al.* 2005). That review provides an overview in changing trends in fishing resulting from the collapse of the groundfish fishery in 1991 and moratoria after 1993. The cod fishery was subjected to a moratorium from 1994 to 1996 and again in 2003. A limited fishery was allowed in 2004 with a total allowable catch (TAC) of 3,500 tonnes. Between 1985 and 2004, species harvest trends show a decline in groundfish catches to zero in 1995 and 1996 with marginal catches below 10,000 tonnes, total. Shrimp and crab catches have risen and replaced groundfish as the more valuable fisheries. Besides increased effort, there is an ecological reason. With reduced groundfish stocks, predation on shrimp and crab by adult cod decreased allowing the crustacean populations to flourish (Worm and Myers 2003). In 1985, the 4R harvest by weight was dominated by groundfish (78%), followed by pelagics (16%), and shellfish (7%). In 2004, the 4R harvest was dominated by pelagics (77%), then shellfish (16%) and groundfish (4%).

## **Project Area Fisheries (4Rb, c)**

Table 5.6 shows the landed weight of domestic harvest within NAFO UA 4Rb,c; within the entire Project Area; and in Seismic Survey Option 2.1. The percent of total catch in the Project Area relative to the entire NAFO UA 4Rb,c is also provided. The first seismic survey is proposed to be shot in August to October 2008. Scheduling of subsequent surveys over the remaining seven years will be negotiated with the fishing community.

Table 5.6 Landed Weight of Domestic Harvest

Species and Year	NAFO 4Rb	Seismic Survey Option 2.1		Project Area		NAFO 4Rc	Seismic Survey Option 2.1		Project Area	
	Landed wt. (kilos)	Landed wt. (kilos)	Percent Total Catch	Landed wt. (kilos)	Percent Total Catch	Landed wt. (kilos)	Landed Wt (kilos)	Percent Total Catch	Landed wt. (kilos)	Percent Total Catch
<b>2007</b>										
Capelin						502961				
Cod, Atlantic	516					501				
Crab, Queen/Snow	13905	4369	31.4	4732	34.0	22903			4348	19.0
Hake, white						147				
Halibut	556					1889				
Herring, Atlantic						83406				
Mackerel	19479									
Monkfish (Am angler)	24									
Sandeels/sandlance						2297				
Shrimp, Pandalus Borealis	198644			2223	1.1					
Turbot/Greenland halibut	37861					5974				
<b>2006</b>										
American plaice	2296			334	14.5					
Capelin	132477					2084187				
Cod, Atlantic	43537			45	0.1	4175				
Crab, Queen/Snow	31605	18111	57.3	19796	62.6	87894			21980	25.0
Hake, white	7					201				
Halibut	32587			6270	19.2	13423				
Herring, Atlantic	4072093					4164547				
Mackerel	2608920			35880	1.4	4055895				
Monkfish (Angler)	113									
Redfish	385					560				
Roe, lumpfish	665			86	12.9					
Shark, mako	50									
Shrimp, <i>Pandalus borealis</i>	5427019			138407	2.6	1923				
Skate	289									
Turbot/Greenland halibut	348407			24622	7.1	955				

Table 5.6 Landed Weight of Domestic Harvest

Species and Year	NAFO 4Rb	Seismic Survey Option 2.1		Project Area		NAFO 4Rc	Seismic Survey Option 2.1		Project Area	
	Landed wt. (kilos)	Landed wt. (kilos)	Percent Total Catch	Landed wt. (kilos)	Percent Total Catch	Landed wt. (kilos)	Landed Wt (kilos)	Percent Total Catch	Landed wt. (kilos)	Percent Total Catch
Winter flounder	2									
Wolfish, Striped/ Atlantic	239									
<b>2005</b>										
American plaice	1296	192	14.8	206	15.9	1282				
Capelin	1671353					1596200			13631	0.9
Cod, Atlantic	51905	210	0.4	501	1	23026				
Crab, Queen/Snow	137756	69343	50.3	83471	60.6	286511	546	0.2	44511	15.5
Greyscale/ witch						2347				
Hake, white	4					131				
Halibut	36442			12692	34.8	17454				
Herring, Atlantic	1604257					5504683				
Lobster						3209				
Mackerel	3179748					1842039				
Monkfish (Angler)	80			4	5					
Redfish	246					1981				
Seal skins, harp, beater (no.)						0				
Shark, mako	354					110				
Shrimp, <i>Pandalus borealis</i>	5600553			640179	11.4					
Skate	293	87	29.7	129	44.0	50				
Turbot/Greenland halibut	465593	5133	1.1	37202	8.0	11837				
Winter Flounder	42									
<b>2004</b>										
Alewife/gaspereau	2									
American plaice	676	2	0.3	2	0.3					
Capelin	540482			17760	3.3	2088531				
Cod, Atlantic	43930	3179	7.2	6527	14.9	6488				
Crab, Queen/Snow	83969	494	0.6	60761	72.4	426753	2136	0.5	58058	13.6

Table 5.6 Landed Weight of Domestic Harvest

Species and Year	NAFO 4Rb	Seismic Survey Option 2.1		Project Area		NAFO 4Rc	Seismic Survey Option 2.1		Project Area	
	Landed wt. (kilos)	Landed wt. (kilos)	Percent Total Catch	Landed wt. (kilos)	Percent Total Catch	Landed wt. (kilos)	Landed Wt (kilos)	Percent Total Catch	Landed wt. (kilos)	Percent Total Catch
Greysole/witch	5									
Hake, white	44			4	9.1	30				
Halibut	24301	2067	8.5	3262	13.4	25243				
Herring, Atlantic	174328					5939471			66261	1.1
Mackerel	2172390			63809	2.9	10408120				
Monkfish (Angler)	357									
Redfish	240									
Roe, lumpfish	102									
Shrimp, <i>Pandalus borealis</i>	4981750	544902	10.9	925463	18.6					
Skate	480					983				
Turbot/Greenland halibut	380922	8518	2.2	27995	7.3	1857				
Winter flounder	26									



The most significant fisheries, by landed weight, in the Project Area are for shrimp, snow crab, turbot/Greenland halibut, halibut, mackerel, herring and capelin, with high variability between the observed years.

Within the Survey Area, snow crab accounts for about half the fishing effort in NAFO 4Rb, ranging from 50.3 to 59.8% between 2004 and 2006 (2007 is incomplete for records) and only 0.2 to 0.5% of NAFO 4Rc landings. There was no shrimp fishing in the Survey Area in 2004 to 2007. About 0.9% of the 4Rc capelin landings were taken in 2005, no other landings for this fish were recorded in other years. There as a small portion of cod caught in the Survey Area within the 4Rb unit; in 2005 there was 0.4 % (210 kgs) taken and in 2004 3.9% (1724 kgs) landed.

In the offshore waters of 4Rb and 4Rc, outside of the Project Area, groundfish such as cod, American plaice, redfish and to a much lesser extent winter flounder and skate, are significant fisheries. Lobster fishing is pursued near the coast in waters typically less than 40 m water depth and thus there will be no interaction with lobster fisheries from this Project.

As shown in Table 5.7, economically shrimp, mackerel, herring, turbot, halibut and snow crab are the most lucrative fisheries in NAFO 4Rb and 4Rc. The shrimp fishery is the most valued fishery with returns in the millions of dollars level. Comparatively, within the Seismic Survey Area and as described above snow crab is the main fishery. The landed value reflects the landed percentage of about 50% on catches in NAFO 4Rb. The landed value of snow crab catches in the Seismic Survey Area is more than an order of magnitude less than NAFO 4Rc landed values.

**Table 5.7 Commercial Harvest (Landed Value \$) From 2004 to 2007 Within the Project Area**

Species and Year	NAFO 4Rb	Seismic Survey 2. 1	Project Area	NAFO 4Rc	Seismic Survey 2.1	Project Area
<b>2007</b>						
Capelin				141,930		
Cod, Atlantic	676			658		
Crab, Queen/Snow	47,295	15,009	16,355	80,827		15,723
Hake, white				100		
Halibut	3,354			11,813		
Herring, Atlantic				17,101		
Mackerel	6,313					
Monkfish (Angler)	4					
Sand eels/sandlance				0		
Shrimp, <i>Pandalus borealis</i>	179,551		2,009			
Turbot/Greenland halibut	69,812			11,016		
<b>2006</b>						
American plaice	1,606		235			
Capelin	37,383			588,134		
Cod, Atlantic	49,698		53	4,911		
Crab, Queen/Snow	68,148	39,873	43,580	193,470		48,242
Hake, white	4			141		
Halibut	203,856		39,220	84,073		
Herring, Atlantic	795,988			860,684		
Mackerel	455,099			1,318,176		
Monkfish (Angler)	19		116,28			
Redfish	256			533		
Roe, lumpfish	1,321		57			
Shark, mako	30					
Shrimp, <i>Pandalus borealis</i>	4,305,346		111,848	1,526		
Skate	76					
Turbot/Greenland halibut	642,420		45,397	1,766		
Winter flounder	1					
Wolffish, Striped/ Atlantic	84					
<b>2005</b>						
American plaice	884	136	146	904		
Capelin	479,007			457,468		3,907
Cod, Atlantic	56,049	212	524	24,218		
Crab, Queen/Snow	460,790	224,609	279,089	949,482	1,865	148,089
Greysole/witch				2,069		
Hake, white	3			78		
Halibut	232,114		80,833	111,224		

Table 5.7 Commercial Harvest (Landed Value \$) From 2004 to 2007 Within the Project Area

Species and Year	NAFO 4Rb	Seismic Survey 2. 1	Project Area	NAFO 4Rc	Seismic Survey 2.1	Project Area
Herring, Atlantic	391,714			1,346,725		
Lobster				37,571		
Mackerel	1,141,886			670,345		
Monkfish (Angler)	55		2			
Redfish	121			1,022		
Seal skins, harp, beater (no.)				25,864		
Shark, mako	234			65		
Shrimp, <i>Pandalus borealis</i>	5,185,709		592,759			
Skate	80	21	31	12		
Turbot/Greenland halibut	894,889	9,866	71,506	22,761		
Winter Flounder	16					
<b>2004</b>						
Alewife/gaspereau	0					
American plaice	579		1			
Capelin	156,261		5,090	598,571		
Cod, Atlantic	50,966	2,106	7,615	7,745		
Crab, Queen/Snow	456,088	274,525	330,339	2,316,808	11,632	315,104
Greyscale/witch	5					
Hake, white	21		2	14		
Halibut	160,714		21,571	166,921		
Herring, Atlantic	26,784			916,590		10,226
Mackerel	583,442		16,881	2,739,079		
Monkfish (Angler)	229					
Redfish	102					
Roe, lumpfish	551					
Shrimp, <i>Pandalus borealis</i>	5,085,006		944,648			
Skate	115			233		
Turbot/Greenland halibut	656,631		48,215	3,365		
Winter flounder	12					

Landed value will fluctuate annually and it is not the point of this assessment to give weight of adverse impact to certain fisheries based on value of the harvest. NWest recognizes the value of the catch is important to every single fisher, regardless if multiple or single license holders.

### 5.3.1.1 Seasonality

Aside from the winter seal harvesting, the majority of mobile and fixed gear fishing occurs between April and November with some herring fishing extending into December. There will be no interaction with seal harvesting and this Project and it is, therefore, not discussed further.

The most active fishing period for all fisheries is from May to July. For the shellfish species, snow crab are fished from April to July and shrimp are fished from April through to October, although the fishery is open from April 1 to December 31. For the pelagic species, capelin fishing effort occurs in June with a minor component in July; mackerel and herring are fall fisheries with the most effort for mackerel are in September to October; and herring from August to December, preceded by a smaller spring fishery. Table 5.8 presents the months on which most landings of a particular species have occurred from 2003 to 2007 in the Project Area. The most landings occur within the months that are highlighted.

**Table 5.8 Monthly Landings of Main Fisheries Occurring in the Project Area (2004 to 2007)**

Species	Jan	Feb	Mar	Apr	May	Jun	Jul	Aug	Sep	Oct	Nov	Dec
Shrimp												
Snow crab												
Mackerel												
Herring												
Capelin												
Turbot												
Halibut												

### 5.3.1.2 Northern Shrimp

In terms of quantity and value, northern shrimp has replaced much of the value lost from the decline in the groundfisheries. Shrimp are harvested using a specially designed (to reduce bycatch of finfish) shrimp trawl. Most of the shrimp catches in the Affected Area are made in Unit Area 4Rb within EL 1104. Division 4R falls within the Gulf of St. Lawrence Shrimp Fishing Area 8, otherwise known as Esquiman. Figure 5.22

shows the landings and TAC in the Esquiman region. There was a 10% increase in catch from 2005 and 2006 (DFO 2006a).

**Figure 5.22 Landing and Total of Admissible Catch by Year for Northern Shrimp in NAFO Division 4R**

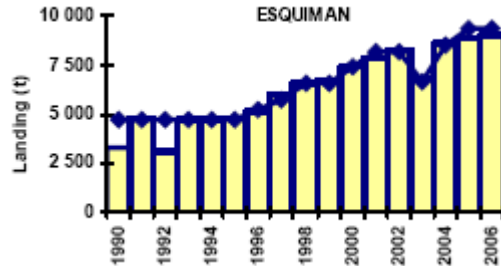
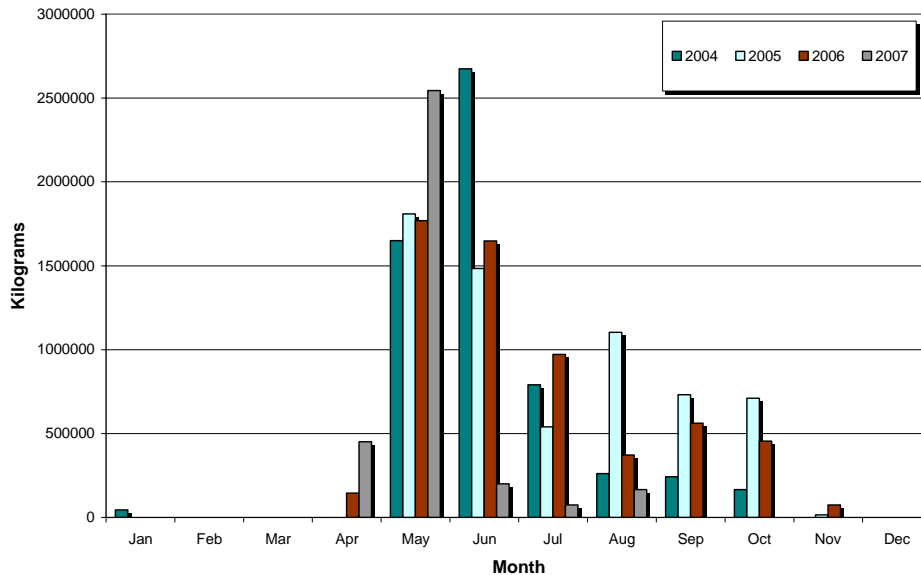
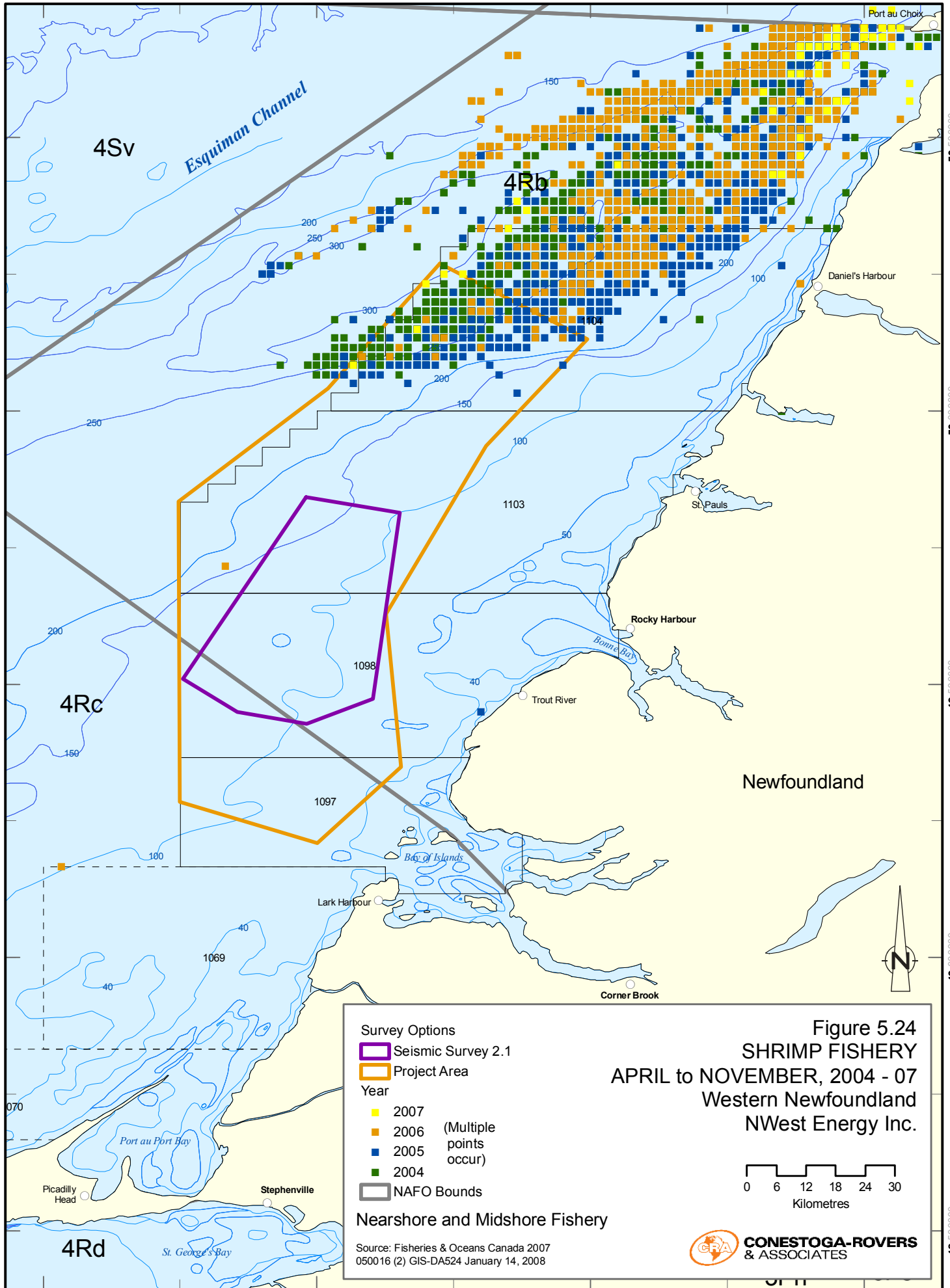


Figure 5.23 shows the majority of fishing occurs in May and July. Figure 5.24 shows the location is consistent year to year in the deeper waters (>200 m) and Figure 5.25(a,b) shows distributional effort by month.



**Figure 5.23 Shrimp Harvest Effort by Month in 4Rb,c ( 2004 - 2007)**

There was no shrimp catch in the proposed Seismic Survey Area Option 2.1 from 2004 to 2007. Within the overall Project Area, shrimp catches accounted for 1.1 to 18.6% of total shrimp catch in 4Rb. No shrimp catches were reported in the Project Area portion of 4Rc.



50.000000  
50.000000  
49.500000  
49.000000  
48.500000

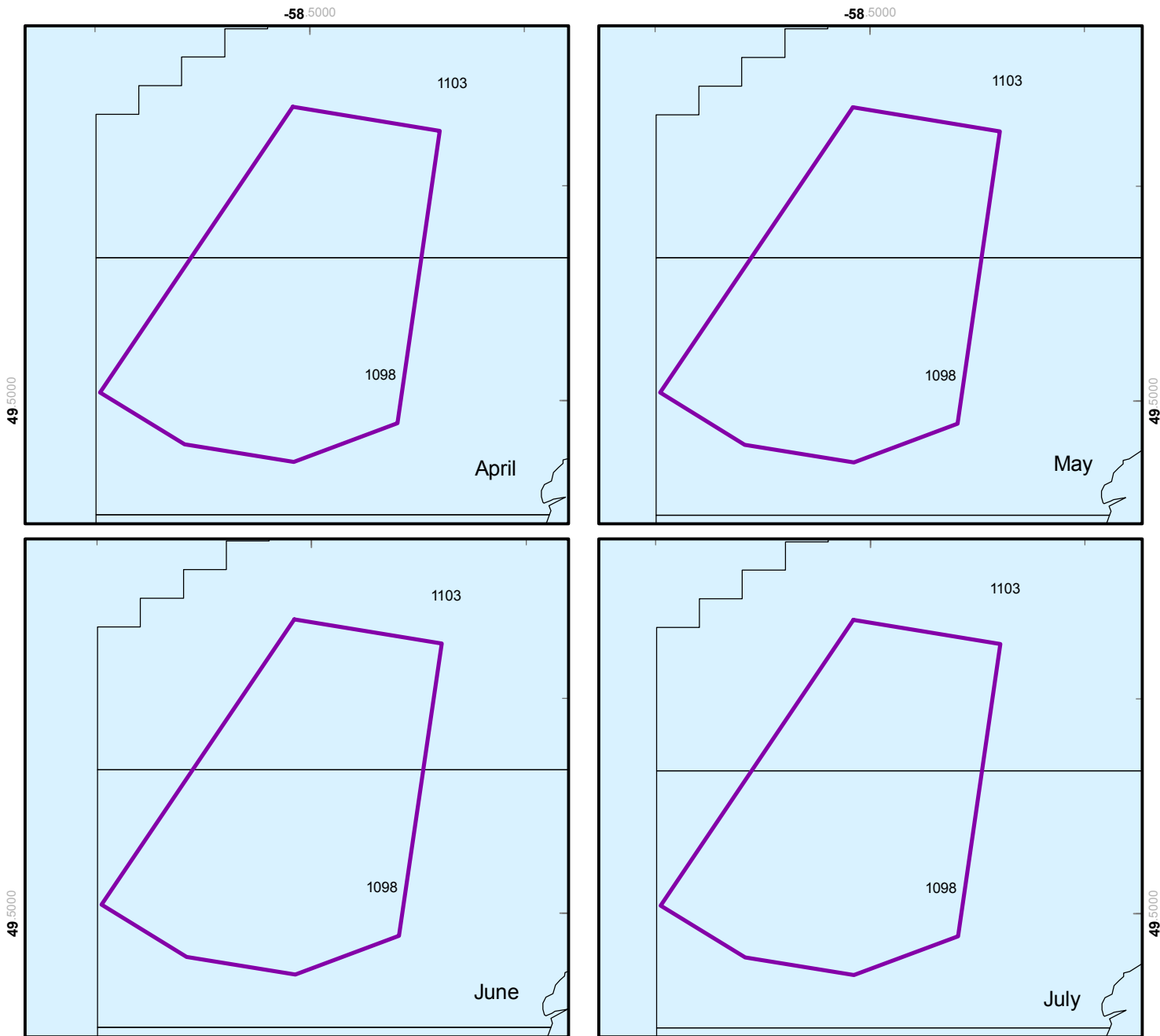





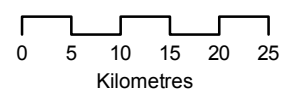


Figure 5.25a  
 SHRIMP FISHERY 2004 - 2007  
 SURVEY OPTION 2.1  
 Western Newfoundland  
 NWest Energy Inc.

-  Seismic Survey 2.1
- Year**
-  2007
-  2006
-  2005
-  2004



Source: Fisheries & Oceans Canada 2007  
 050016 (2) GIS-DA525a January 15, 2008



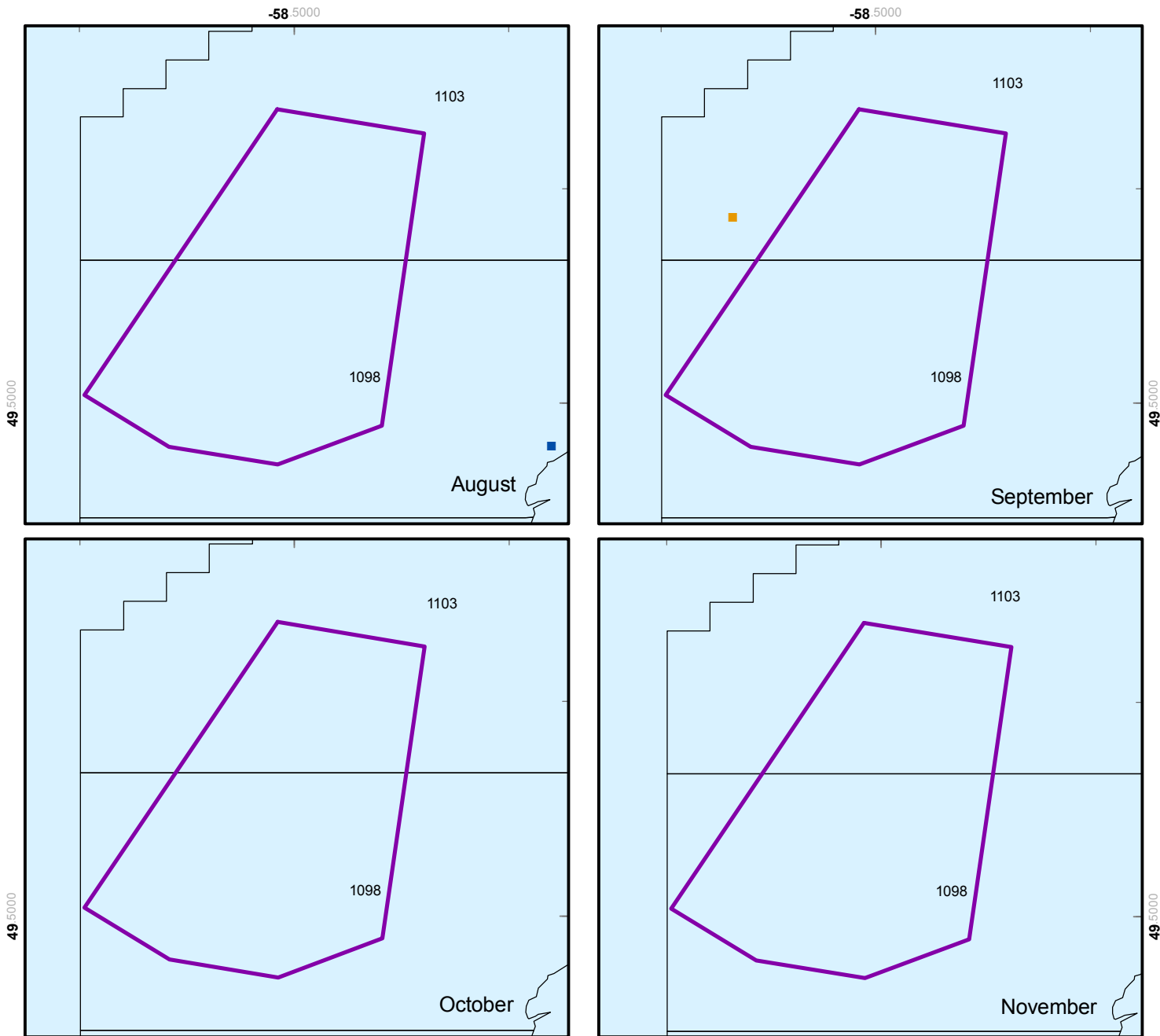





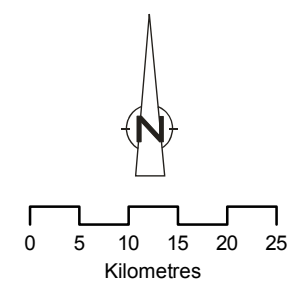


Figure 5.25b  
 SHRIMP FISHERY 2004 - 2007  
 SEISMIC SURVEY 2.1  
 Western Newfoundland  
 NWest Energy Inc.

-  Seismic Survey 2.1
- Year**
-  2007
-  2006
-  2005
-  2004



Source: Fisheries & Oceans Canada 2007  
 050016 (2) GIS-DA525b January 14, 2008

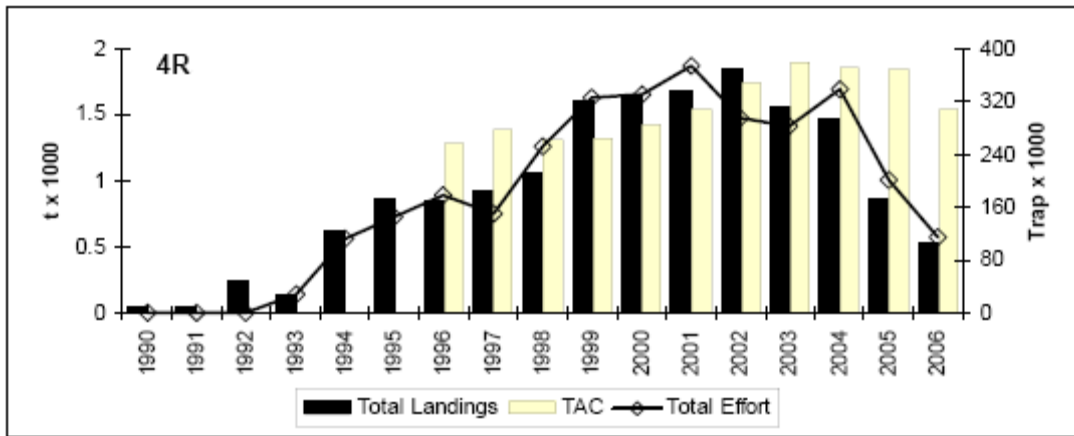




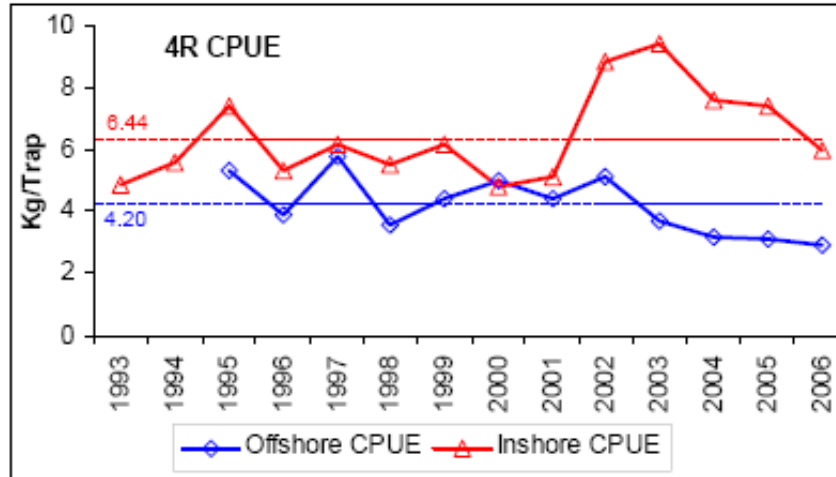
### 5.3.1.3 Snow Crab

A snow crab fishery began in Division 4R in 1993. Snow crab are harvested using bottom set crab traps (pots). A surface float marks the location for retrieval. During recent years, most of the snow crab catches have occurred in Unit Area 4Rc and the southern part 4Rb (ELs 1097, 1098). There has been a pronounced change in the distribution of effort from north to south in recent years (DFO 2005c). The snow crab fishery in the area that overlaps with the northern 4Rb portions of the SEA Affected Area was placed under moratorium in 2003. According to the DFO Science Advisory Report (2007/008) landings (Figure 5.26) peaked in 2002 at 1850 t landings and declined by 71% since 2002 to their historic low of 540 t in 2006. Yet the TAC remained high. Effort decreased to its lowest level since 1995. There are insufficient data to assess resource status.

**Figure 5.26 Trends in Snow Crab TAC, Landings, and Fishing Effort in NAFO UA 4R**

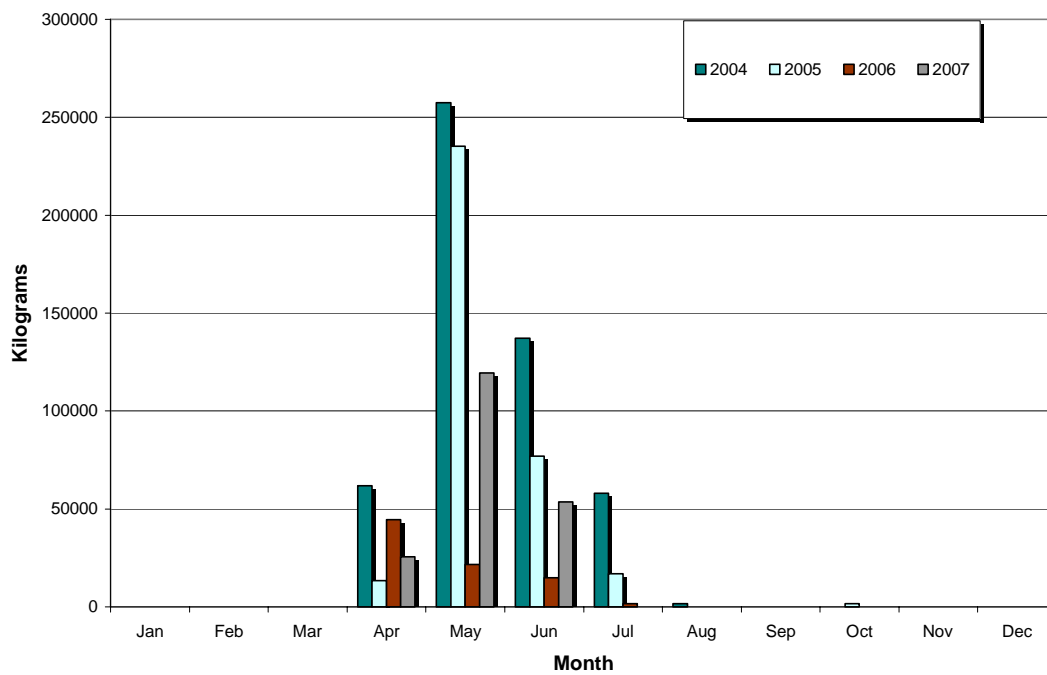


It is not possible to infer trends in exploitable biomass from commercial CPUE data because of recent changes in the spatial distribution (steady contraction) of fishing effort. CPUE (Figure 5.27) is higher in inshore than in offshore areas but is low relative to other divisions.

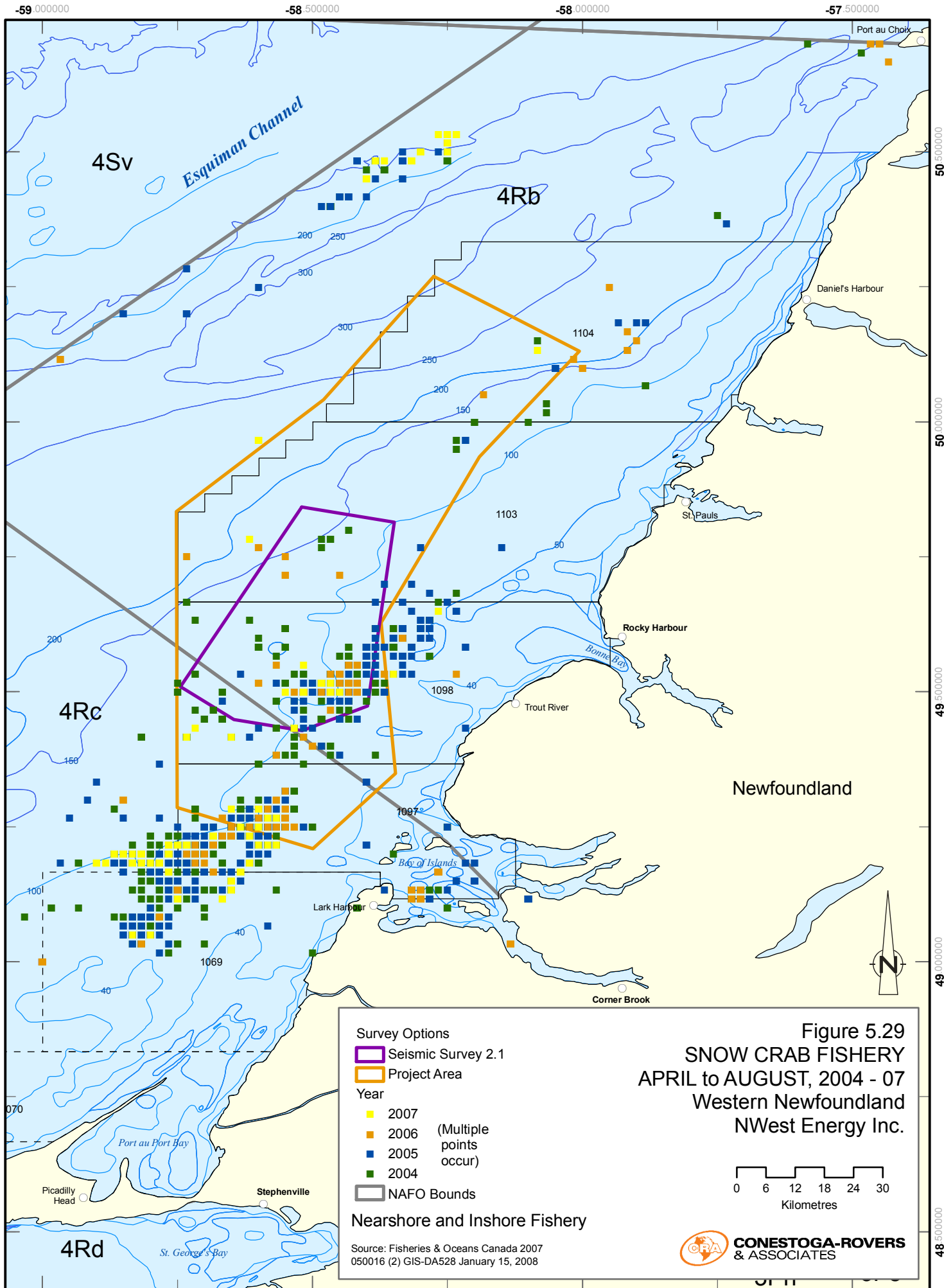


**Figure 5.27 Catch Per Unit Effort of Snow Crab in 4R**

There are defined clusters of harvesting effort offshore of the Bay of Islands and Bonne Bay. Figures 5.28 and 5.30 shows the effort by month. Figure 5.29 shows the location of georeferenced snow crab harvest for 2004 to 2007.



**Figure 5.28 Snow Crab Harvest Effort by Month in 4Rb,c (2004-2007)**



-59.000000

-58.500000

-58.000000

-57.500000

50.500000

50.000000

49.500000

49.000000

48.500000

4Sv

4Rb

4Rc

4Rd

Esquiman Channel

Port au Port Bay

St. George's Bay

Port au Choix

Daniel's Harbour

St. Pauls

Rocky Harbour

Bonne Bay

Trout River

Bay of Islands

Lark Harbour

Corner Brook

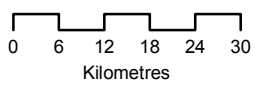
Picadilly Head

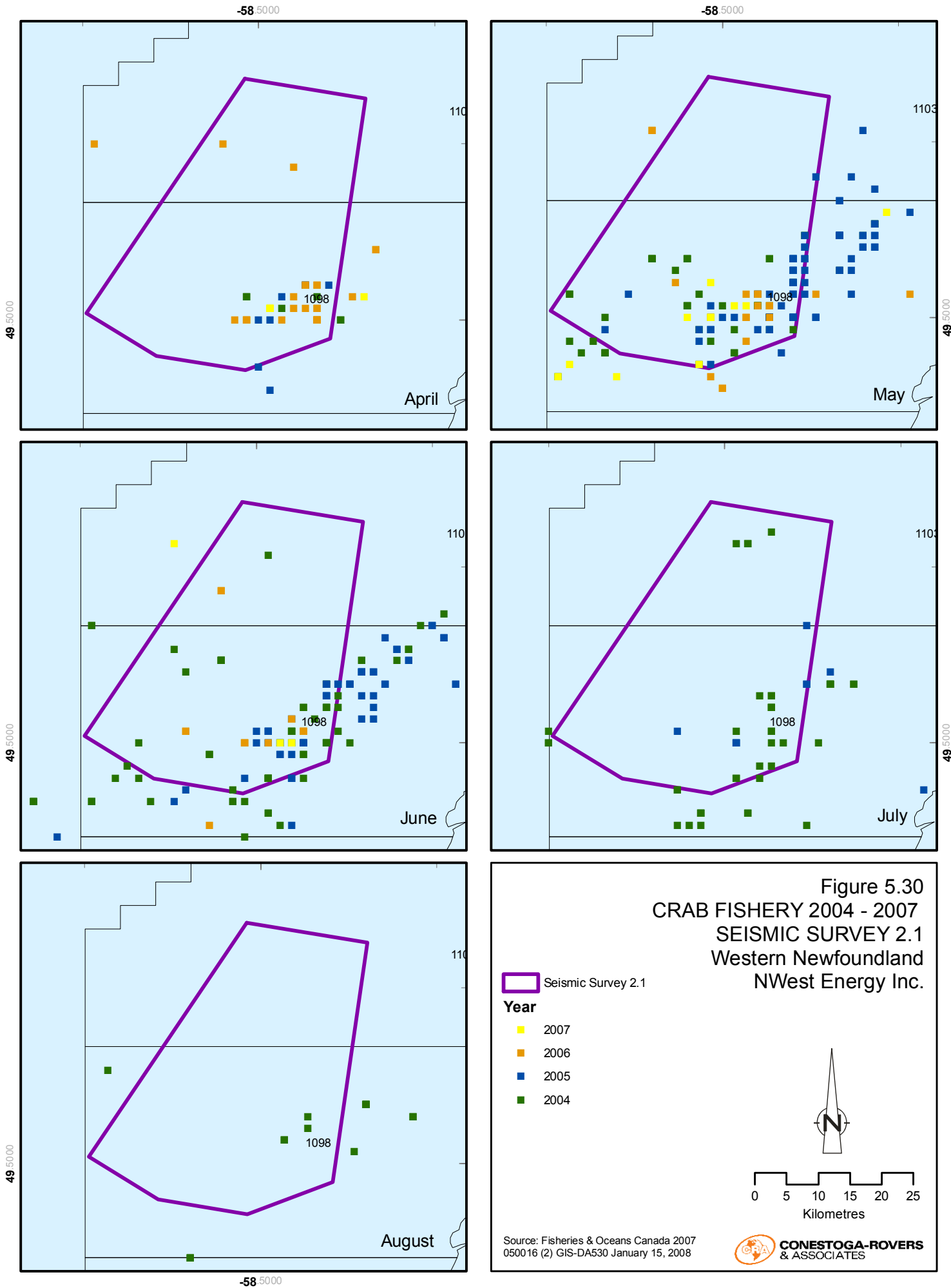
Stephenville

Newfoundland



- Seismic Survey 2.1
- Project Area
- Year
  - 2007
  - 2006 (Multiple points occur)
  - 2005
  - 2004
- NAFO Bounds





#### 5.3.1.4 Lobster

Lobsters are fished using baited traps (pots) with a surface buoy tethered for retrieval. The lobster fishery is very lucrative and undertaken between April and June. Georeferenced data for lobster is sparse and what data does exist poorly describes the effort. However, lobsters are fished in the shallow waters of the coastline no deeper than 50 m of water, and therefore will not conflict with the seismic survey vessel. Lobster Fishing Areas 13B and 14A fall within the exploration licenses. An aboriginal fishery, Federation of Newfoundland Indians (FNI), for lobster takes place in St. Georges Bay and Bay of Islands (Figure 5.31).

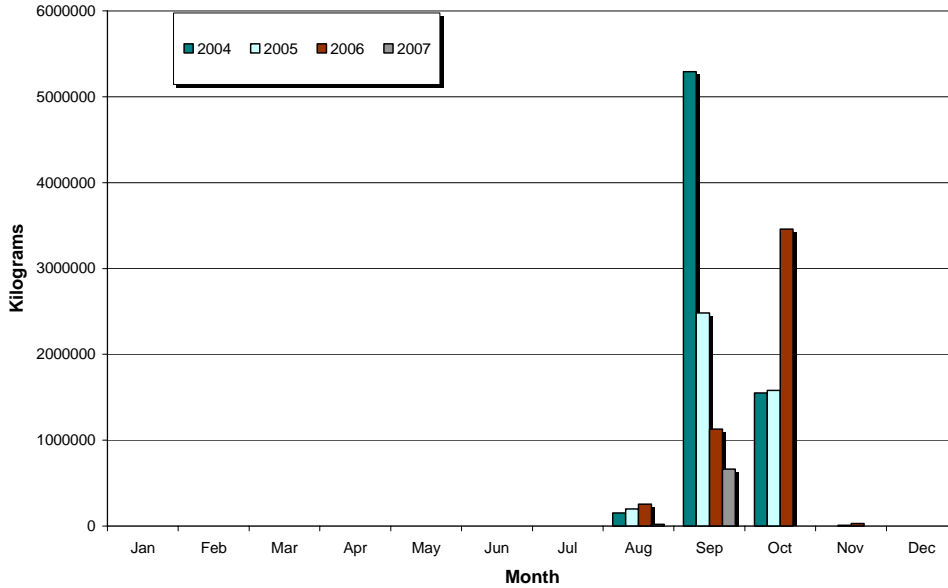


**Figure 5.31** Location of Aboriginal Lobster Fishing

#### 5.3.1.5 Mackerel

Mackerel are caught primarily using purse seines; traps, gillnets, lines and weirs are also employed in the harvest. The mackerel harvest is considerable in landed weight in 4Rb and 4Rc, but it is less economical compared to shellfish harvesting. There is no regulated season for mackerel, but it is mainly pursued from August to October (Figure 5.32). The fishery occurs in water depths less than 50 m and often during the night. Figure 5.33 shows the distributional effort from 2004 to 2007. Therefore, this proposed Project will present minimal interference with this fishery. About 1.4% of the mackerel catch in 2006, and 2.9% in 2004 within 4Rb occurred in the Study Area. There were no

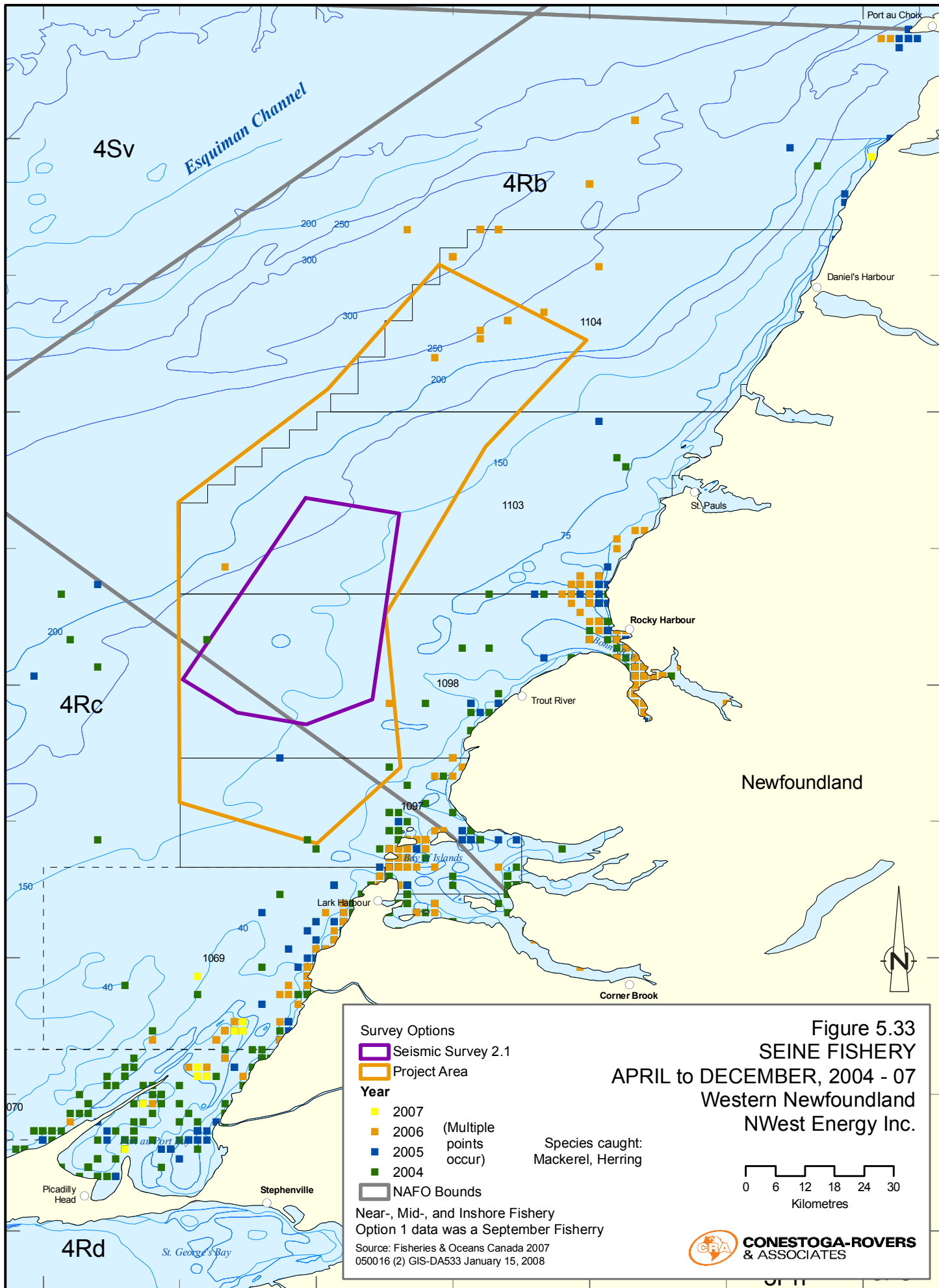
catches of mackerel in Survey Area Option 2.1 over those same years. However, mackerel caught and used for bait or the recreational fishery are not recorded into DFO statistical branch.



**Figure 5.32 Mackerel Harvest Effort by Month in 4Rb,c ( 2004-2007)**

**5.3.1.6 Herring**

Herring are caught mostly with purse seines and to a lesser degree by gillnet. Herring account for a very large component of the harvest in 4Rbc, but not within the Project Area (Figure 5.33). Of the recorded data, 1.1 % of the herring catch in 4Rc in 2004 was within the Project Area, and nothing in the other recent years. Like mackerel fishing, the bait fishery for herring is not recorded. The herring fishery occurs from over two seasons, a small spring fishery from April to June and a more substantial fall fishery from October to December (Figure 5.34). The fishery occurs in water depths less than 50m and again is well beyond the boundary of the Project Area, thus there is no anticipated vessel/gear interference.



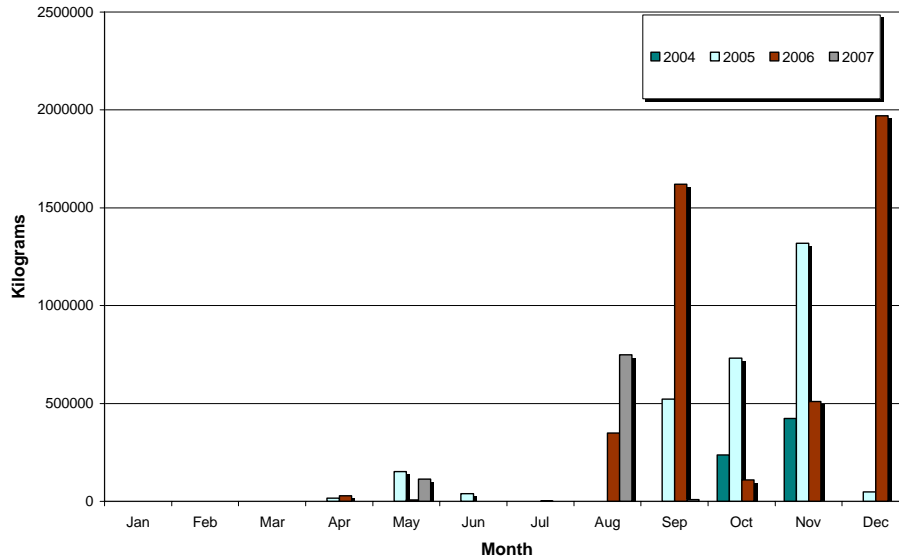
50.000000

50.000000

49.500000

49.000000

48.500000

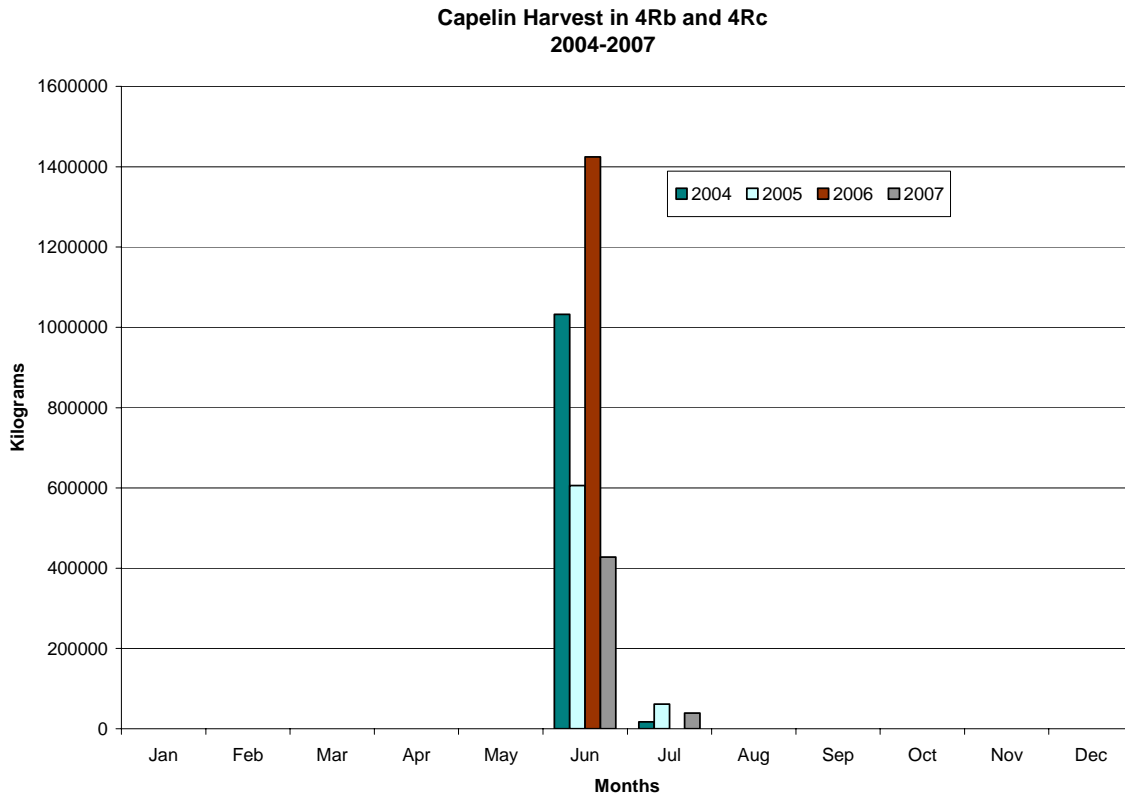


**Figure 5.34 Herring Harvest Effort by Month in 4Rb,c (2004-2007)**

### 5.3.1.7 Capelin

Capelin are caught using purse seines during June and July when the fish aggregate to spawn offshore (Figure 5.35). Based on the recorded harvest, capelin fishing occurred in the Project Area in 2004 and accounted for only 3.3% of the overall catch in 4Rb, and in 2005, accounted for 0.9% of the capelin harvest in 4Rc. No capelin were caught in the Seismic Survey Area Option 2.1. Unit Areas 4Ra, 4Rb and 4Rc account for much of the capelin landings in 4RST. Capelin on the west coast of Newfoundland have shown a recent size increase but are still smaller than those observed in 1980s. The most intensive capelin fishery in 4R occurs in June and July (Figure 5.36). The purse seine fishery typically occurs near the stretch of coast between Bonne Bay and Port au Port (*i.e.*, 4Rb and 4Rc, including nearshore areas of area EL 1097 and EL 1098). Between 2000 and 2004, the most highly concentrated capelin catches in the Project Area occurred in the Bay of Islands and Bonne Bay (4Rc; EL1097 and part of EL1098) (DFO 2005b).

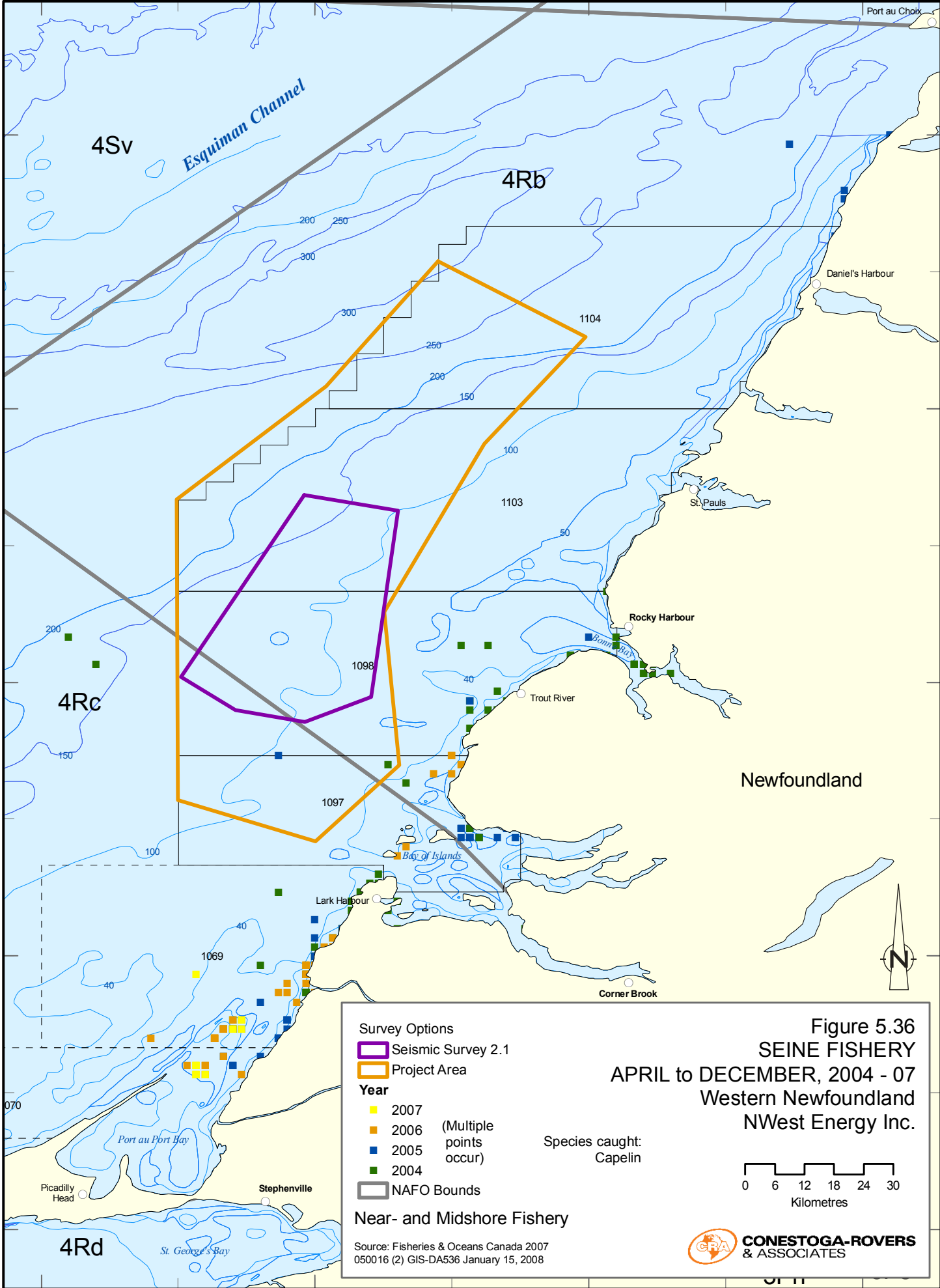




**Figure 5.35 Capelin Harvest Effort by Month in 4Rb,c (2004-2007)**

### 5.3.1.8 Turbot/Greenland Halibut

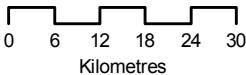
As for the other groundfish species, Greenland halibut are pursued by means of gillnet and longline (Figures 5.37 to 5.40) primarily during the months of May and June (Figure 5.41). According to DFO Science Advisory Report 2006/011 “Fishery results were generally good in 2005, and forecasts indicate that they will remain at a good level for 2006, but probabilities are high that fishery success will drop over the next few years. The TAC was increased in 2004 to take advantage of the 1997 and 1999 year classes. In 2006, catches equal to the 2005 TAC should create an increase in fishing pressure because the Greenland halibut biomass available to the fishery should decrease.” Landed catch distributions in 2004 indicated that most of the Greenland halibut caught within the Project Area were taken in Unit Area 4Rb beyond the 100 m isobath (EL1103 and EL1104) (DFO 2005d). Between 2004 and 2007, turbot catch in Seismic Survey Area Option 2.1 and the Project Area accounted for 1.1% (only in 2005), and 7.1 to 8.0%, respectively, of the 4Rb harvest. There were no records of turbot harvesting in the Project Area in NAFO 4Rc. The species is caught predominantly in June in the last three years.



**Figure 5.36**  
**SEINE FISHERY**  
**APRIL to DECEMBER, 2004 - 07**  
**Western Newfoundland**  
**NWest Energy Inc.**

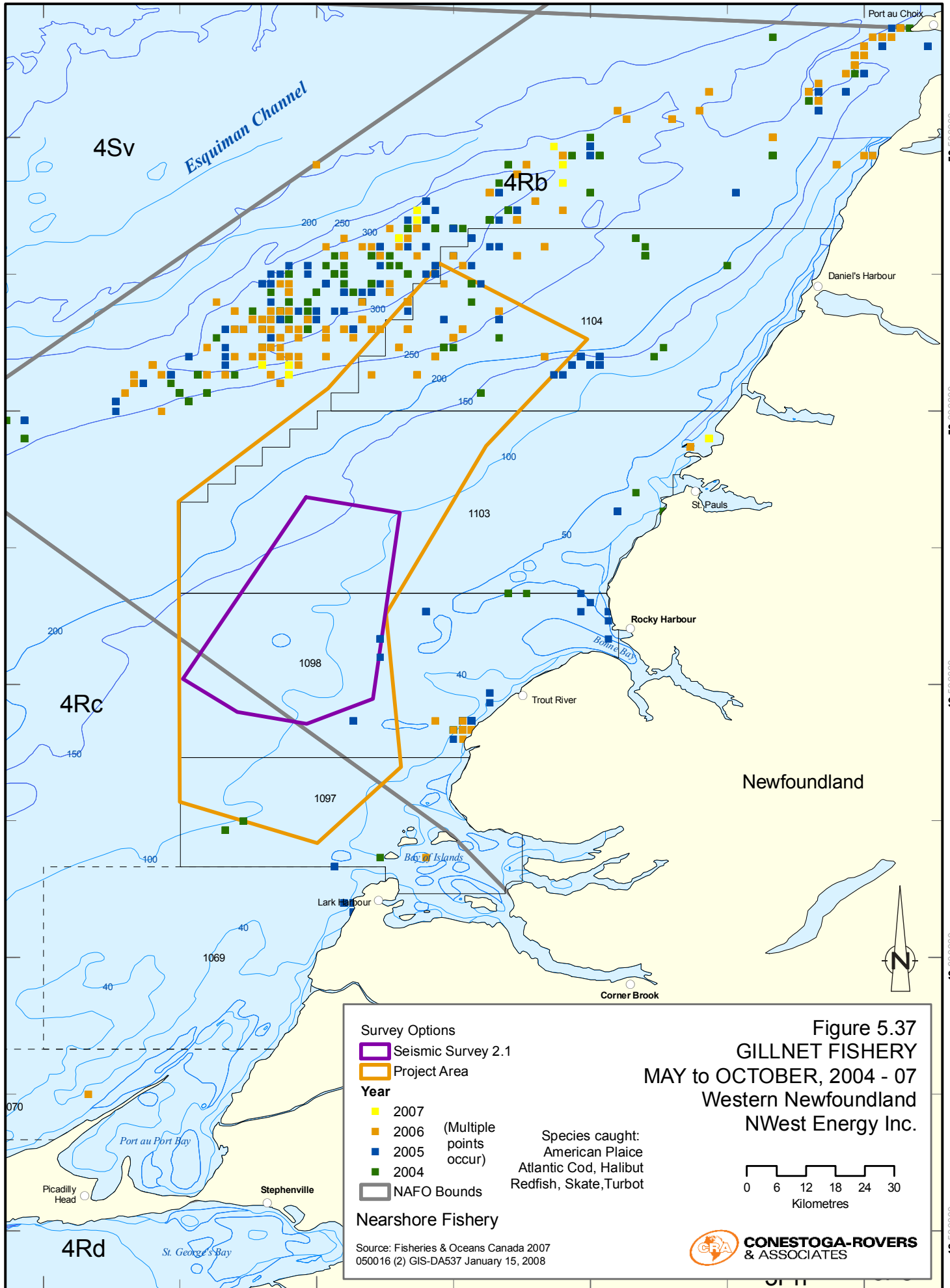
- Survey Options**
- Seismic Survey 2.1
  - Project Area
- Year**
- 2007
  - 2006 (Multiple points occur)
  - 2005
  - 2004
- NAFO Bounds

Species caught:  
 Capelin



**Near- and Midshore Fishery**

Source: Fisheries & Oceans Canada 2007  
 050016 (2) GIS-DA536 January 15, 2008



50.000000

50.000000

49.500000

49.000000

48.500000

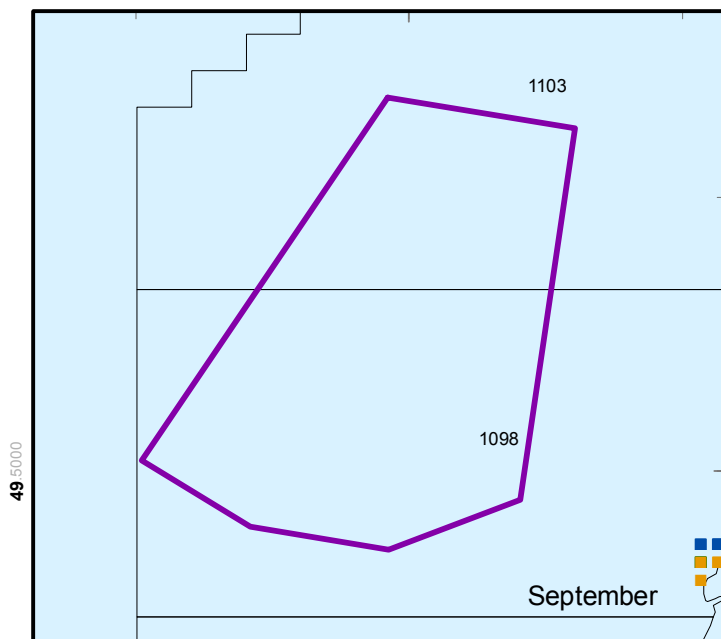
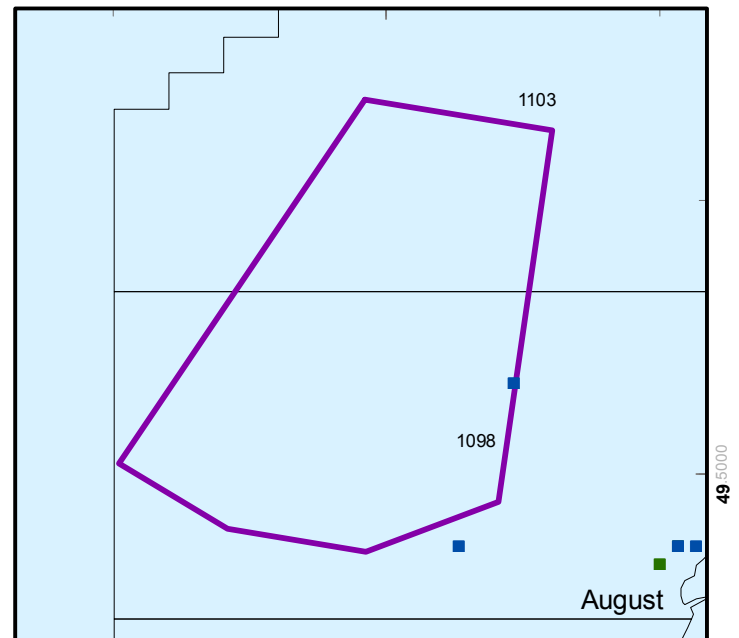
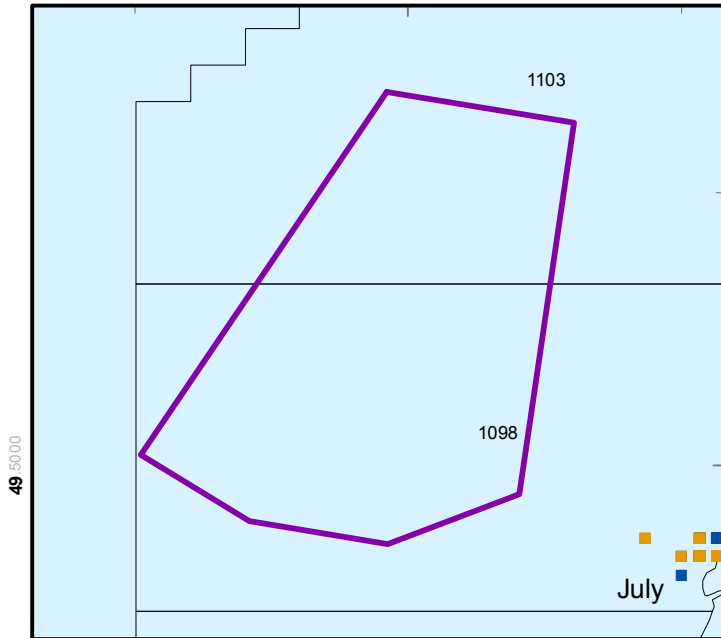
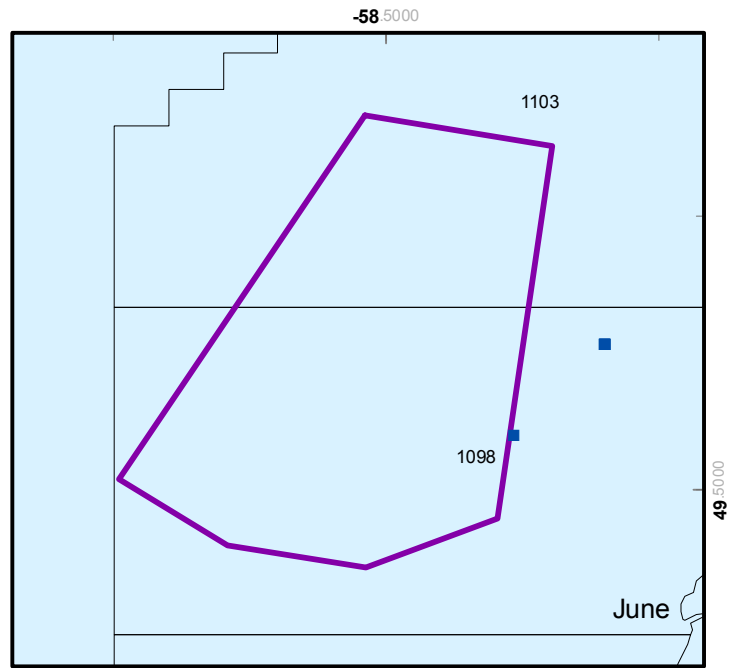
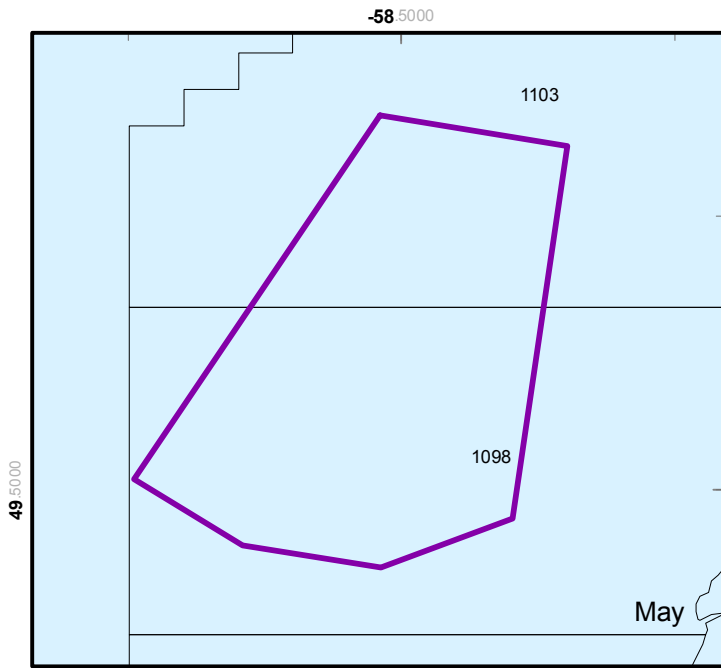





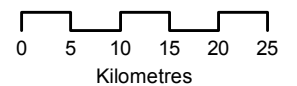
Figure 5.38  
 GILLNET FISHERY 2004 - 2007  
 SURVEY OPTION 2.1  
 Western Newfoundland  
 NWest Energy Inc.

 Seismic Survey 2.1

**Year**

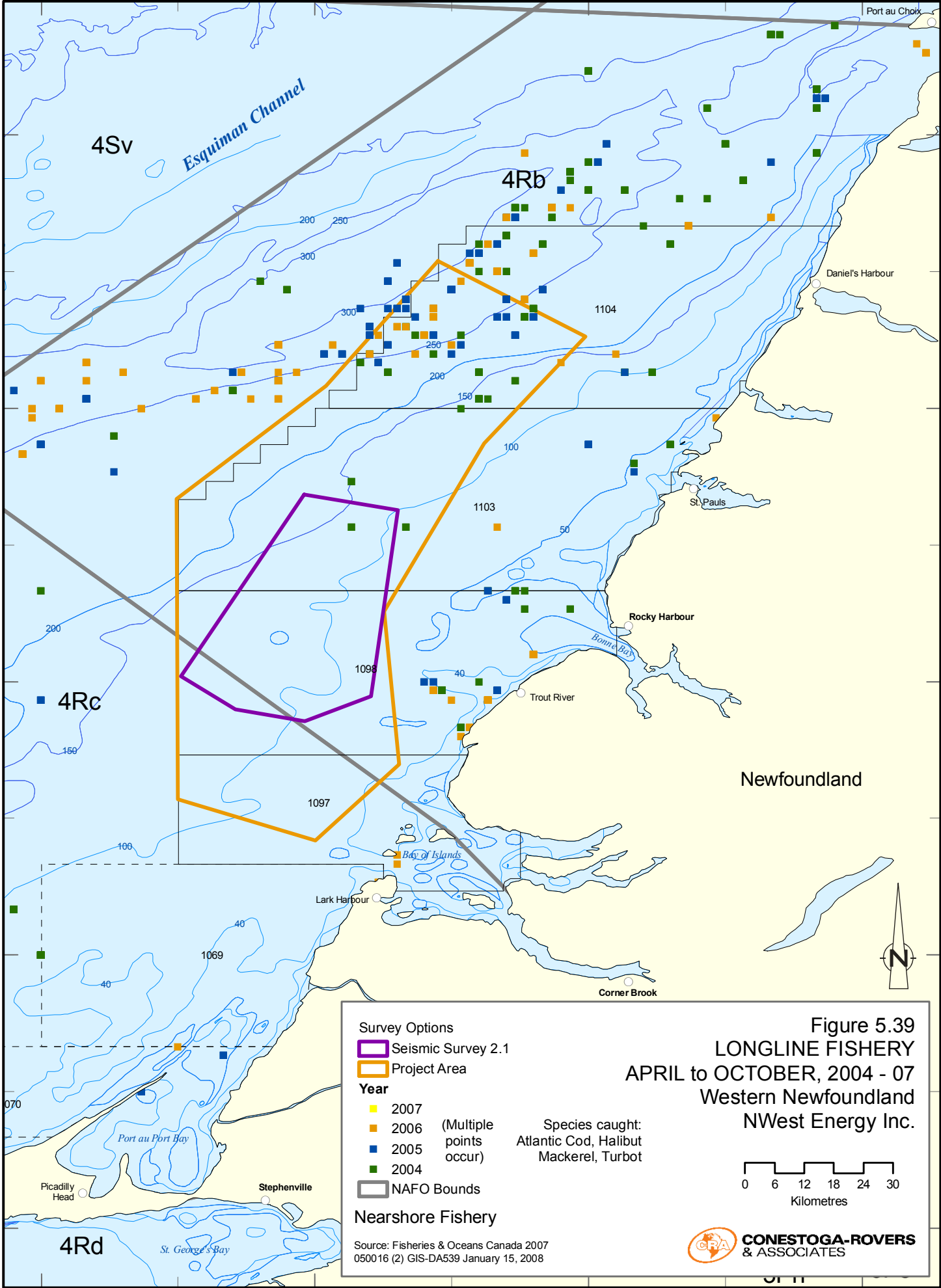
-  2007
-  2006
-  2005
-  2004

Species caught:  
 American Plaice  
 Atlantic Cod, Halibut  
 Redfish, Skate, Turbot



Source: Fisheries & Oceans Canada 2007  
 050016 (2) GIS-DA538 January 15, 2008



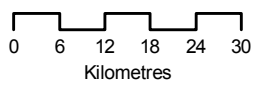


50.000000  
50.000000  
49.500000  
49.000000  
48.500000

**Figure 5.39**  
**LONGLINE FISHERY**  
**APRIL to OCTOBER, 2004 - 07**  
**Western Newfoundland**  
**NWest Energy Inc.**

- Survey Options**
- Seismic Survey 2.1
  - Project Area
- Year**
- 2007
  - 2006 (Multiple points occur)
  - 2005
  - 2004
- NAFO Bounds

Species caught:  
 Atlantic Cod, Halibut  
 Mackerel, Turbot



**Nearshore Fishery**

Source: Fisheries & Oceans Canada 2007  
 050016 (2) GIS-DA539 January 15, 2008



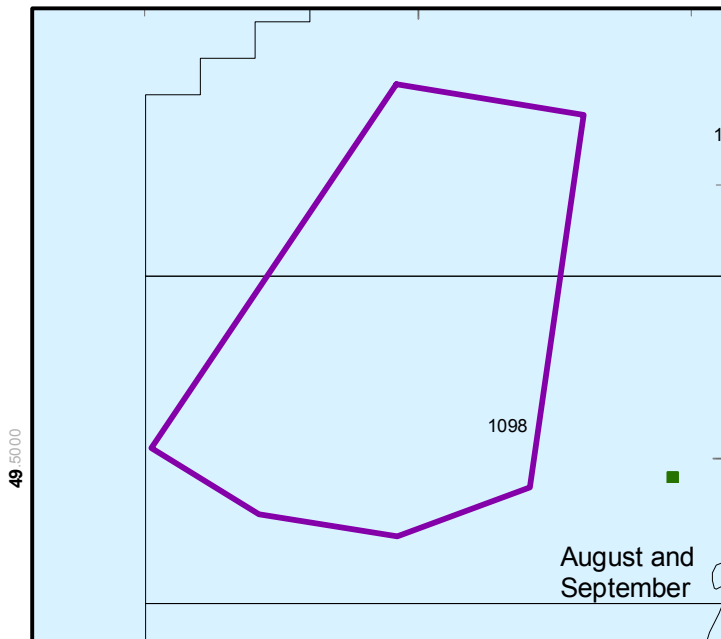
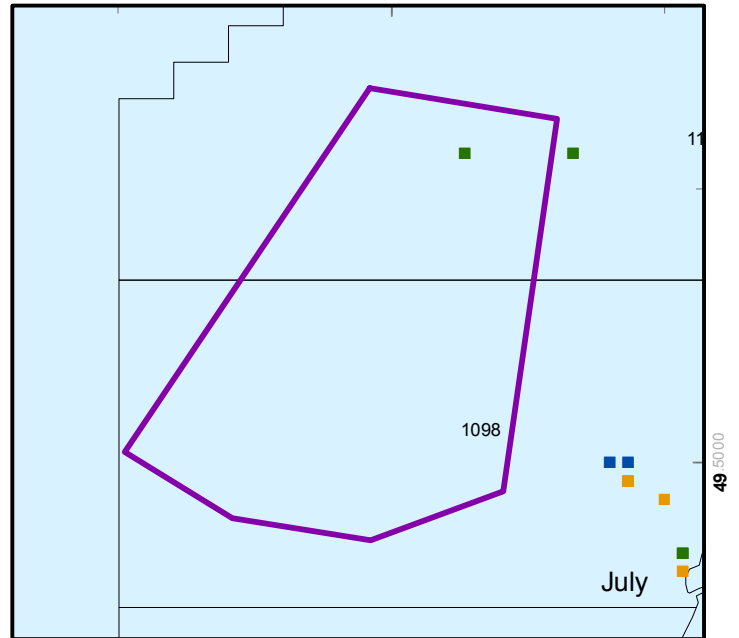
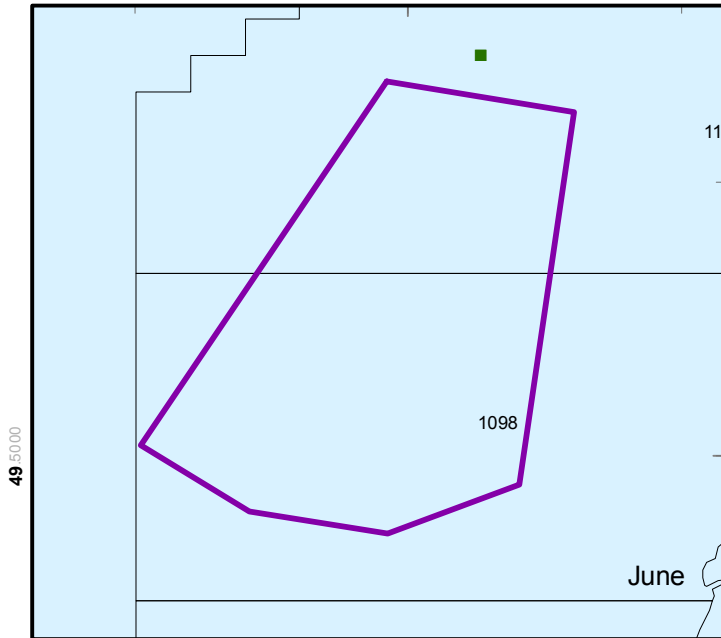
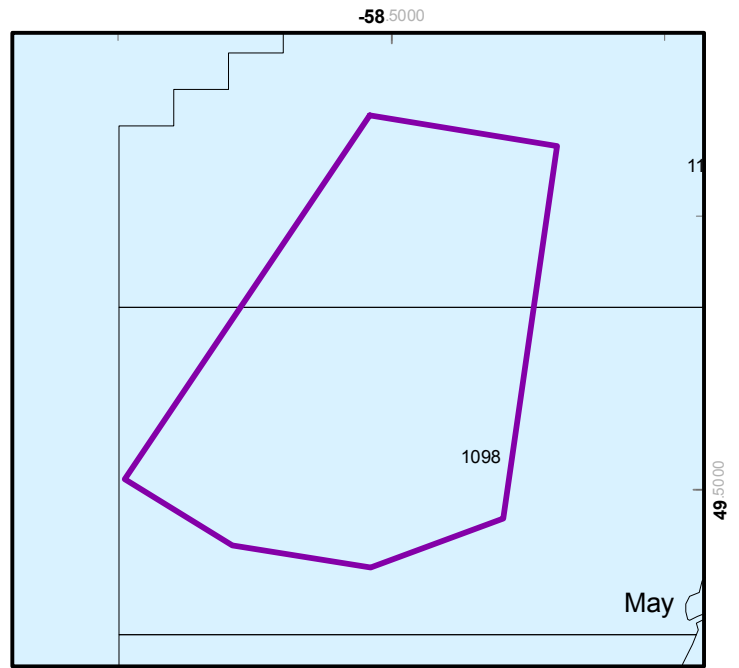
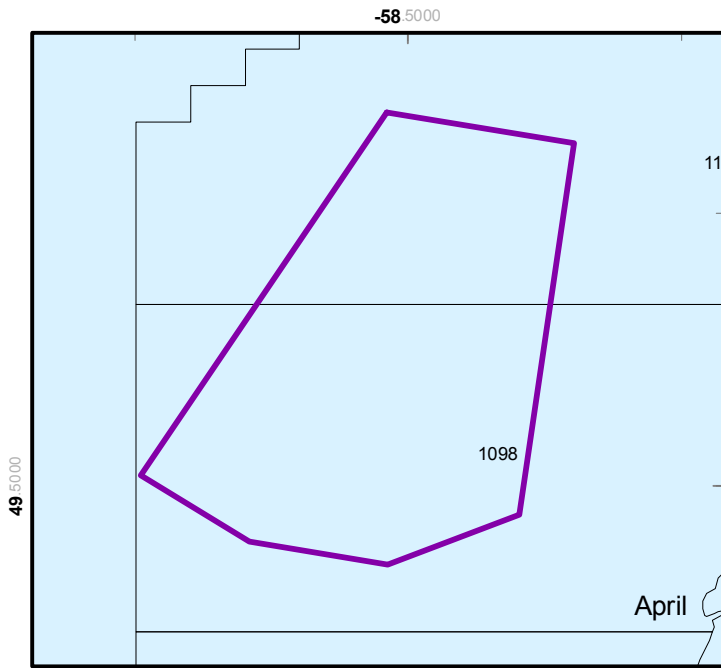






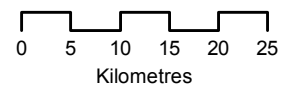
Figure 5.40  
**LONGLINE FISHERY 2004 - 2007**  
**SEISMIC SURVEY 2.1**  
 Western Newfoundland  
 NWest Energy Inc.

 Seismic Survey 2.1

**Year**

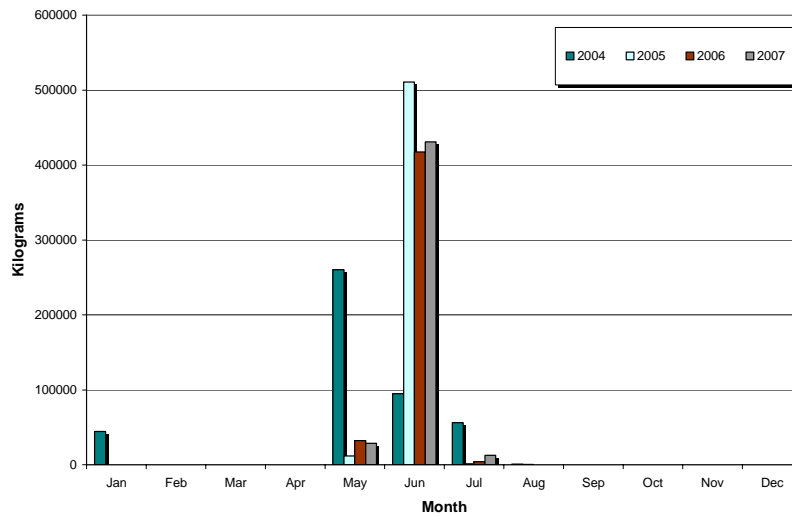
-  2007
-  2006
-  2005
-  2004

Species caught:  
 Atlantic Cod  
 Halibut, Turbot



Source: Fisheries & Oceans Canada 2007  
 050016 (2) GIS-DA540 January 15, 2008

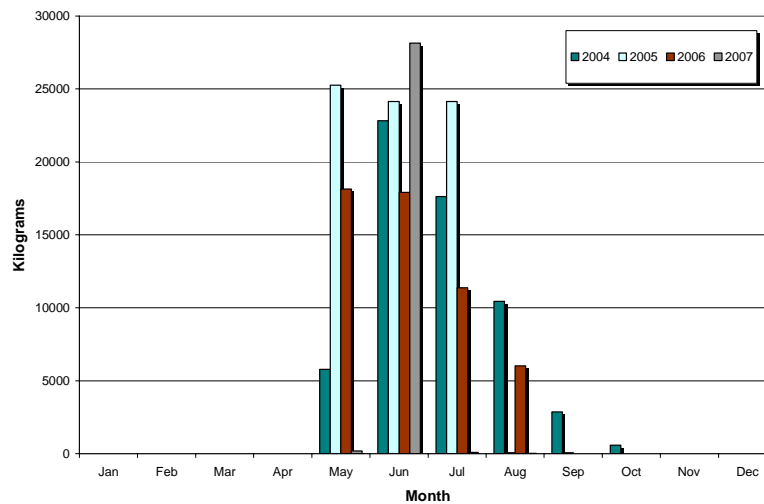




**Figure 5.41 Turbot Harvest Effort by Month in 4Rb,c (2004-2007)**

### 5.3.1.9 Halibut

Halibut are caught primarily on longlines, with a minor component caught by gillnet and otter trawl (Figure 5.37 to 5.40). Most of the Atlantic halibut caught within the Project Area and landed at Newfoundland ports in 2004 were taken in the offshore areas of 4Rb, primarily beyond the 200 m isobath (1104) (DFO 2005e). Between 2004 and 2007, halibut catch in Seismic Survey Option 2.1 and the Project Area accounted for 8.5 to 12.1%, and 13.4 to 34.8%, respectively, of the 4Rb harvest. There were no records of halibut harvesting in the Project Area in 4Rc. Fishing occurs mostly from May to August (Figure 5.42).



**Figure 5.42 Halibut Harvest Effort by Month in 4Rb,c (2004-2007)**

### 5.3.1.10 Cod

The cod fishery was under moratorium in 2003 and then re-opened under small quotas in 2004. The 2004 cod catches were distributed primarily in the northern part of the Project Area, from nearshore to the offshore. Exploration Licences 1097 and 1098 reported the most cod catches of the four licenses. Cod landings in Seismic Survey Area Option 2.1 were 0.4% and 3.9% in 2005 and 2004 respectively of the 4Rb NAFO unit. Catches tended to be in the nearshore areas (Figures 5.37 to 5.40) and between June and July (Figure 5.43).

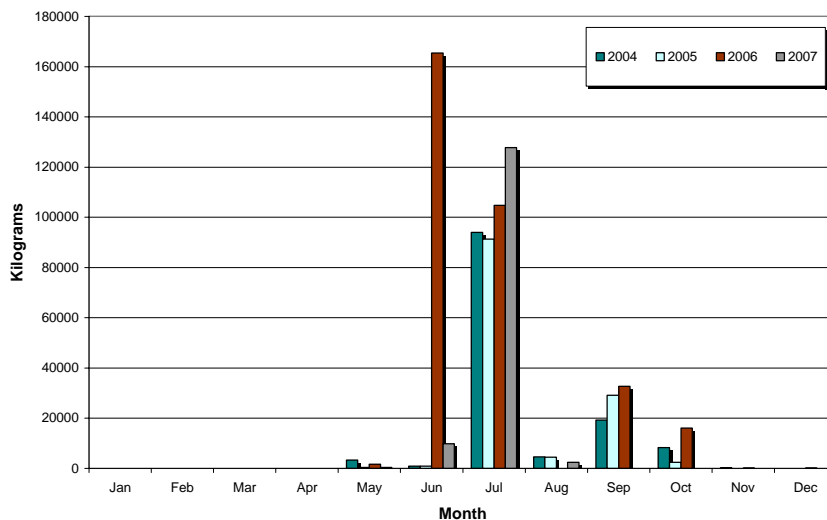


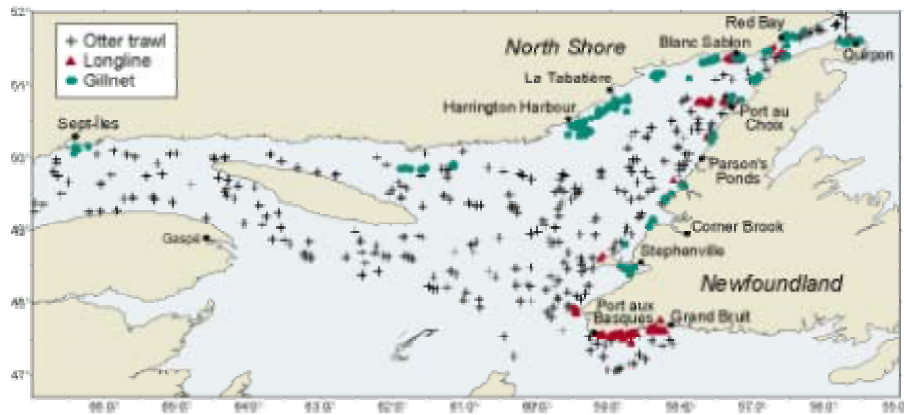
Figure 5.43 Cod Harvest Effort by Month in 4Rb,c ( 2004-2007)

## 5.3.2 Commercial Fishery Surveys

### 5.3.2.1 Sentinel Surveys

Through sentinel fisheries, commercial fishermen and Department of Fisheries and Oceans (DFO) scientists work in partnership, gathering biological data on groundfish stocks under moratorium. Under sentinel fishery projects, commercial fishermen, who are specially trained in data collection methods, gather information on groundfish stocks by fishing in pre-established areas under pre-established guidelines. The sentinel surveys are undertaken in 4R (Figure 5.45) commence in early May (south near Codroy), but the remaining of the NAFO area starts in mid-June and continues through to September. The focus is on cod stocks, however, the by-catch is censused as well.





**Figure 5.44 Sentinel Surveys in the Gulf of St. Lawrence**

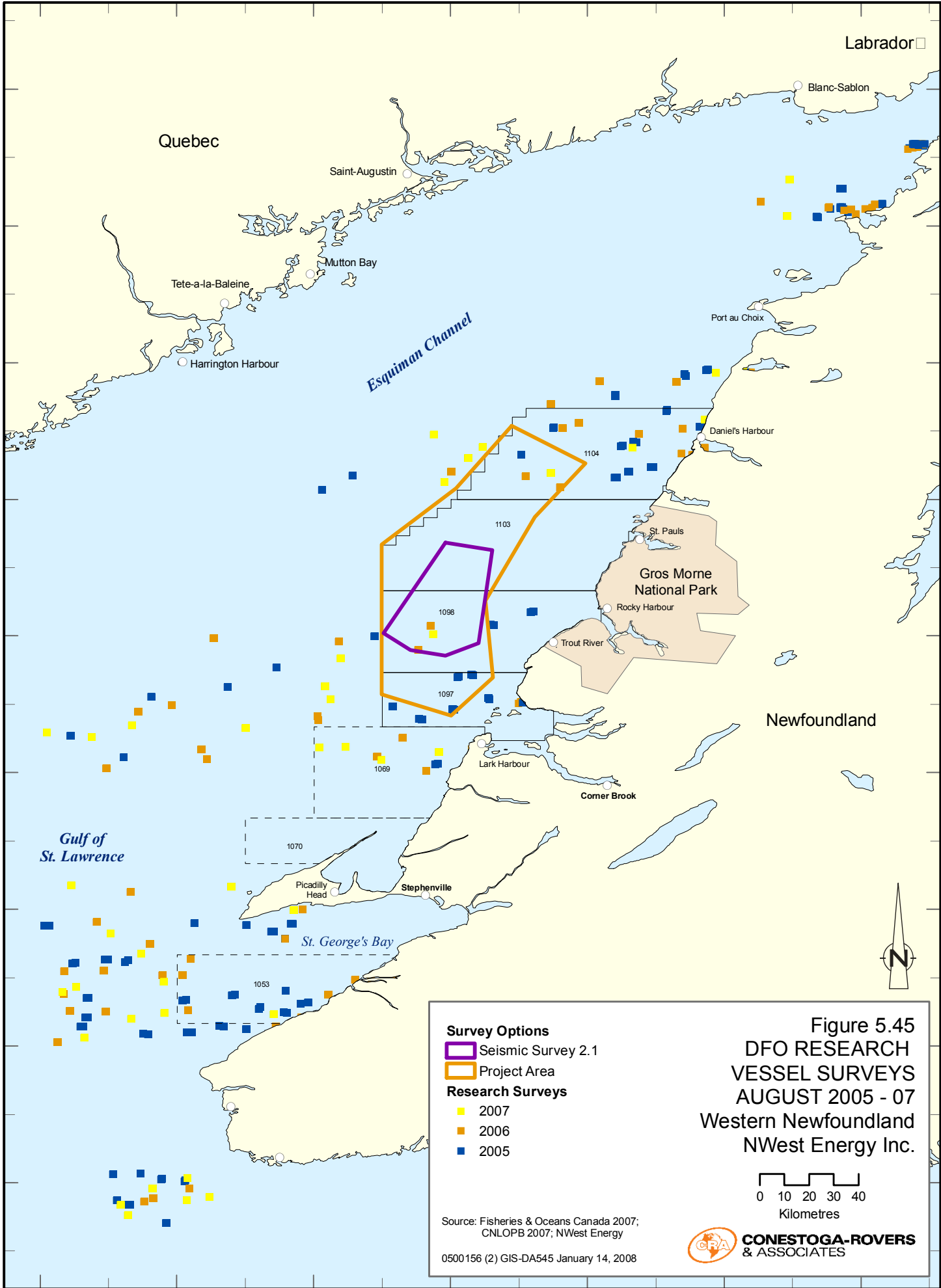
### **5.3.2.2 Research Vessel Surveys**

Separate research vessel surveys are undertaken by DFO, in collaboration with fishers and fishers have their own surveys. DFO surveys are undertaken annually in August (Figure 5.45). The industry surveys are conducted from July 1<sup>st</sup> to July 15<sup>th</sup>. The sentinel fisheries on the west coast of Newfoundland and Labrador involve 21 sites spread out along the coast between Red Bay and Grand Bruit, and there are 11 fishing sites along the Lower North Shore of Quebec from Sept-Îles to Lourdes-de-Blanc-Sablon. The trawlers perform one mobile survey a year in early July. In Newfoundland, five vessels are needed to cover all of 3Pn and 4RBoth RV surveys use bottom trawl and censuses all species caught.

### **5.3.2.3 Groundfish Enterprise Allocation Council**

The GEAC's research surveys provide annual/seasonal indices of catch rate, distribution and abundance for various groundfish species in 3Ps. These surveys are not undertaken in the NAFO 4Rb and 4Rc.

-60.0000 -59.5000 -59.0000 -58.5000 -58.0000 -57.5000 -57.0000



- Survey Options**
- Seismic Survey 2.1
  - Project Area
- Research Surveys**
- 2007
  - 2006
  - 2005

Figure 5.45  
**DFO RESEARCH  
 VESSEL SURVEYS  
 AUGUST 2005 - 07**  
 Western Newfoundland  
 NWest Energy Inc.

0 10 20 30 40  
 Kilometres

Source: Fisheries & Oceans Canada 2007;  
 CNLOPB 2007; NWest Energy  
 0500156 (2) GIS-DA545 January 14, 2008



#### **5.3.2.4 Snow Crab Survey**

Snow crab stock assessments are completed annually to provide a “snapshot” on the future abundance of the stock. The assessment process includes an evaluation of indicators of stock performance of which there are two key indicators – the scientific survey (Fall (September) bottom trawl survey) and the commercial catch rate. The scientific survey data (bottom trawl) measures the residual biomass, or the type and number of crab remaining after the fishery, whereas the commercial catch rate reflects fishery performance during the fishing season. Over time, commercial catch rates and fall surveys provide trends in the overall resource status.

#### **5.3.2.5 Halibut Tagging**

A halibut tagging program of juvenile fish are undertaken during the commercial fishery. There are no extra vessels associated with this survey.

#### **5.3.2.6 Cod Reproductive Survey**

Two otter trawl are distributed to conduct cod reproductive surveys in the spring in NAFO UA 4Rc,d - the cod spawning area. This area as described above is well outside of the Project and Affected Areas.

#### **5.3.3 Aquaculture**

Aquaculture is limited in the west coast of Newfoundland, and is less than 1% of the production in the Gulf of St. Lawrence. According to the NL Department of Fisheries and Aquaculture, there is one blue mussel site on Goose Arm in the Bay of Islands, three Atlantic cod sites in Bonne Bay, one Atlantic salmon farm in Daniel’s Harbour (Figure 5.46). All sites are well beyond the zone of influence of noise from seismic activities.

#### **5.3.4 Marine Traffic**

Shipping lanes (Vessel Traffic Services Zones) are designated well north of the Project Area (Figure 5.47). The majority of commercial shipping in northern Gulf of St. Lawrence is to and from Montreal through the Strait of Belle Isle. Domestic commercial shipping also occurs along the west coast of Newfoundland, both local via the ports of

Stephenville and Corner Brook. Transit along the coast is through the Strait of Belle Isle to northern ports. Information on vessels types were obtained through Transport Canada in St. John's. Bulk carriers pass between Quebec and Voiseys Bay for the nickel mine project, vessels tend to hug the Quebec coastline. Woodward tankers (MV Arctic) are coastal vessels transiting out of Montreal. Tugs and barges are common. Oceanlinks container ships are based in Corner Brook. A cruise ship visits Corner Brook in the falloff the year. In the summer pleasure craft populate the inshore coastal areas.

Figure 5.48 shows vessel traffic on the Scotian Shelf and Cabot Strait. There are indications that a component of marine traffic follows the west coast of Newfoundland. However, Transport Canada, who maintains the ECAREG database, did not provide information for the Regional Area.

-59.0000

-58.5000

-58.0000

-57.5000

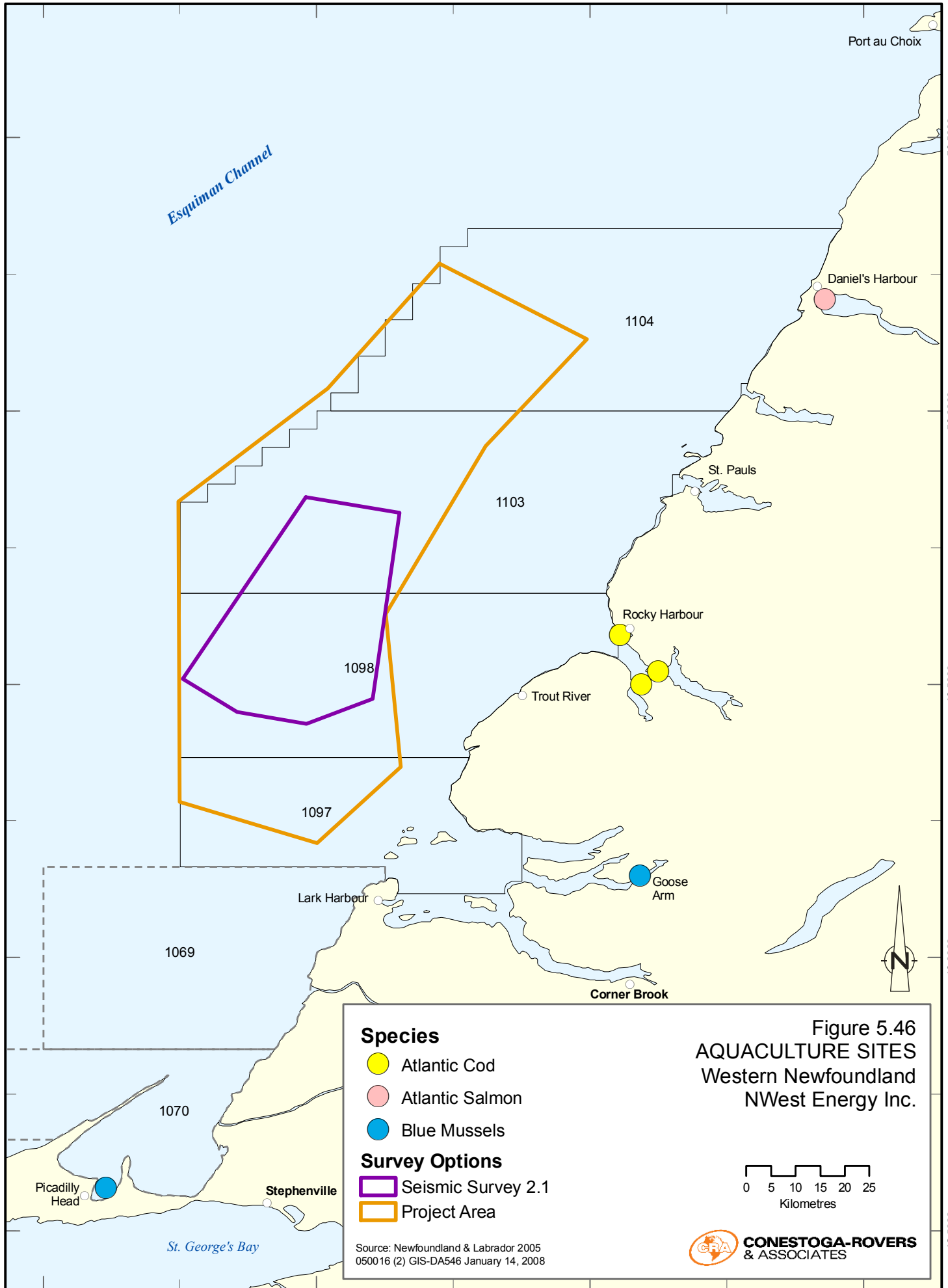


Figure 5.46  
 AQUACULTURE SITES  
 Western Newfoundland  
 NWest Energy Inc.

**Species**

- Atlantic Cod
- Atlantic Salmon
- Blue Mussels

**Survey Options**

- Seismic Survey 2.1
- Project Area

Source: Newfoundland & Labrador 2005  
 050016 (2) GIS-DA546 January 14, 2008

 **CONESTOGA-ROVERS  
 & ASSOCIATES**

50.5000

50.0000

49.5000

49.0000

48.5000

-60.0000

-59.5000

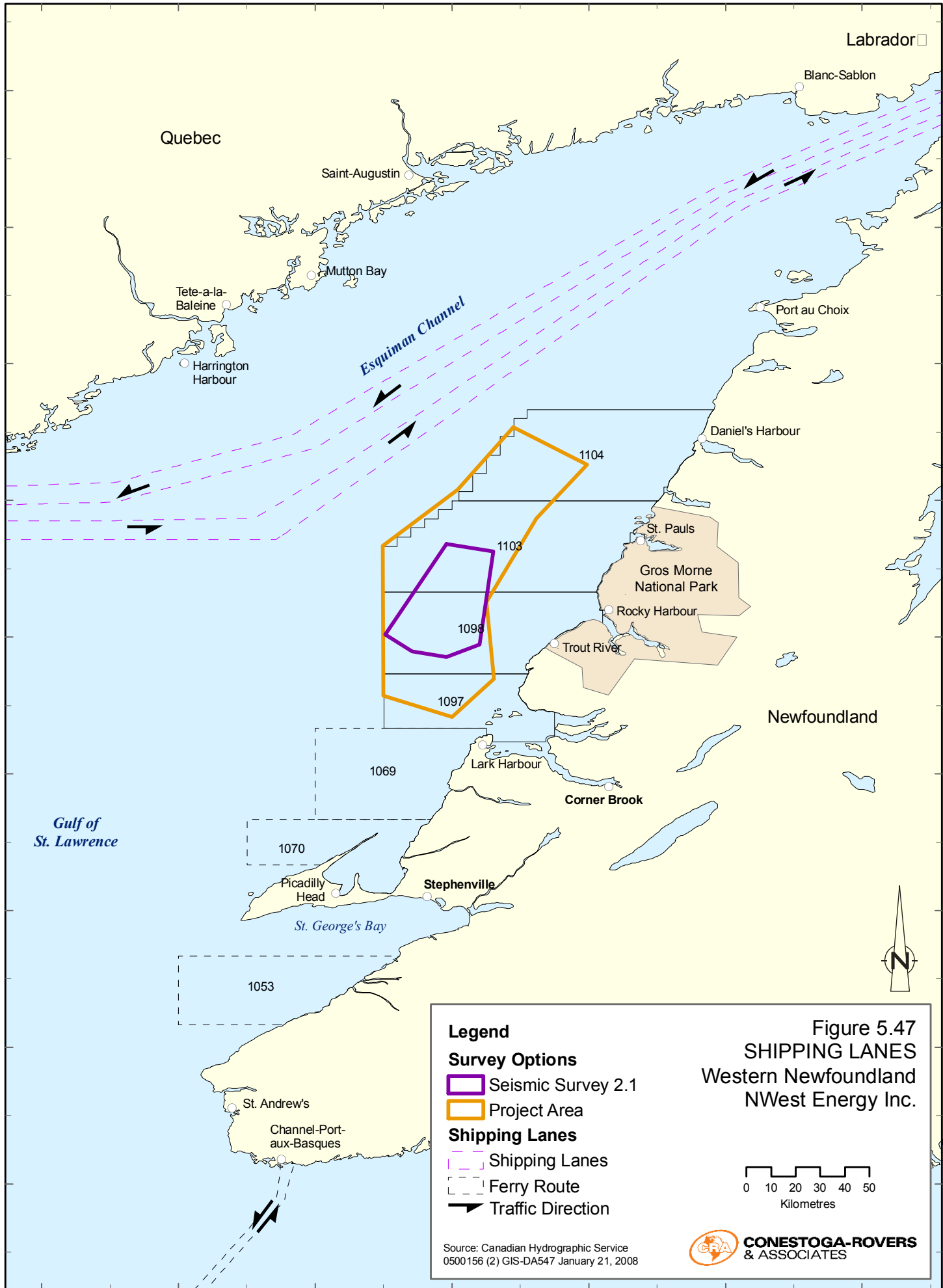
-59.0000

-58.5000

-58.0000

-57.5000

-57.0000



**Legend**

**Survey Options**

Seismic Survey 2.1

Project Area

**Shipping Lanes**

Shipping Lanes

Ferry Route

Traffic Direction

**Figure 5.47**  
**SHIPPING LANES**  
Western Newfoundland  
NWest Energy Inc.

0 10 20 30 40 50  
Kilometres

Source: Canadian Hydrographic Service  
0500156 (2) GIS-DA547 January 21, 2008

**CONESTOGA-ROVERS**  
& ASSOCIATES

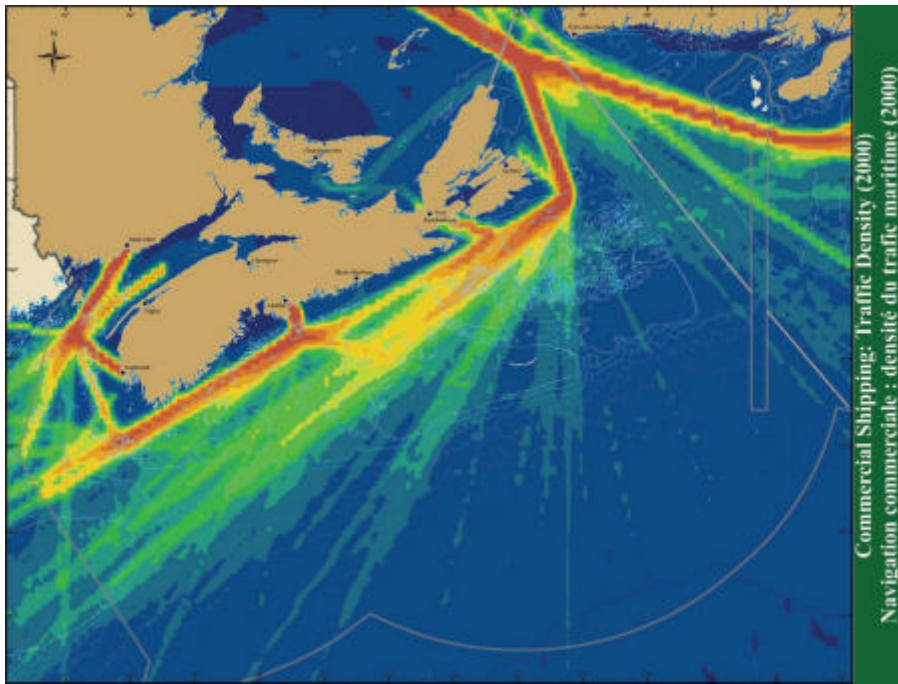


Figure 5.48 Commercial Shipping: Traffic Density (2000)

## 6.0 ENVIRONMENTAL EFFECTS OF PROJECT ACTIVITIES

High intensity noise discharges from seismic surveys are considered to be the most likely activity to impact marine systems. Research carried out in 1994 by the Independent Scientific Review Committee (ISRC), and commissioned by the Australian Petroleum Production Exploration Association (APPEA) and the Energy Research and Development Corporation, found that environmental issues relating to seismic surveys are largely concerned with:

- pathological effects (lethal and sub-lethal injuries) – immediate and delayed mortality and physiological effects to nearby organisms;
- behavioural change to populations of marine organisms;
- disruptions to feeding, mating, breeding or nursery activities of marine organisms in such a way as to affect the vitality or abundance of populations;
- disruptions to the abundance and behaviour of prey species for marine mammals, seabirds and fish; and
- changed behaviour or breeding patterns of commercially targeted marine species, either directly, or indirectly, in such a way that commercial or recreational fishing activities are compromised.

McCauley (1994) found that the response of Australian marine fauna to marine seismic survey noise ranged from no effect to various behavioural changes. McCauley found no evidence that the majority of marine species suffer any lethal or pathological effects as a result of noise from seismic surveys and concluded that “...given the relatively small scale of seismic activity, the often large scales over which biological events occur, the low probability of encounter between seismic surveys and ‘at risk’ populations at an appropriate time and place, then the wider implications of disruption by seismic surveys appear to be small for most species.”

### 6.1 Marine Birds and Migratory Birds

The Gulf of St. Lawrence is occupied by numerous seabird species throughout the ice-free period. Bird populations that occur from May to October are surface feeders (Greater Shearwater, Storm Petrel, Gulls, Kittiwake) and plunge divers (Gannet, Gulls) (Brown 1986). Concentrations of birds are likely to occur in association with food sources, which include shrimp, krill, fish larvae, squid, herring, mackerel, ship waste and detritus. Marine and migratory birds are protected by legislation (*Migratory Birds Convention Act 1994*) and the *Species at Risk Act* and thus, are a regulatory concern.



### **6.1.1 Boundaries**

With respect to temporal boundaries, the potential interactions of concern are those related to the seismic activities that could occur in August to potentially October in 2008 for the first seismic survey, and between May and December for subsequent surveys during a seven-year (2009 to 2015) time period. The ecological spatial boundary for marine bird species includes the breeding, nesting and foraging habitats.

### **6.1.2 Potential Interactions and Issues**

There are no data suggesting that seismic surveys, well site surveys or VSPs have adverse impacts on birds (MMS 2004). Potential impact mechanisms are noise impacts from seismic surveys and disturbance from vessels. Noise produced from these geophysical surveys might only impacts those offshore bird species that spend considerable amount of time underwater, swimming or plunge diving for food. Noise from the surveys could adversely affect surface-feeding and diving seabirds near the air source arrays. A possible mechanism for indirect effects is alteration of prey concentration. However persistent, widespread alterations in abundance of fishes are not expected.

Regulators have expressed concern on effects from attraction of birds to vessel lighting.

Coastal and marine birds could be affected by a spill due to an accident involving the survey vessel.

### **6.1.3 Significance Criteria and Evaluation**

A significant adverse effect on coastal and marine and migratory birds is one likely to cause:

- A death or life-threatening injury of one or more individual of a listed species; and or
- Death or life-threatening injury or non-listed species in sufficient numbers to affect the population adversely; and/or
- Long-term or permanent displacement of any species from preferred feeding, breeding or nursery habitats;
- Destruction or adverse effects of critical habitat for any listed species

An adverse but not significant effect on marine birds and migratory is one that is likely to cause:

- Death or life-threatening injury of individuals in small numbers that would not adversely affect the population; and or
- Short-term displacement of any species from preferred feeding, breeding, nursery grounds or migratory routes

#### **6.1.4 Effects Assessment and Mitigation**

Many species of marine birds utilize habitats within the Affected Area; however, little information on the effects of seismic exploration surveys on these species exists in the scientific literature. Davis *et al.* (1998) suggested the lack of data regarding seabirds and seismic surveys reflects the minimal evidence that any effects occur.

Research on disturbance due to seismic exploration surveys has revealed negligible results. Lacroix *et al.* (2003) studied moulting Long-tailed Ducks (*Clangula hyemalis*) in the Beaufort Sea and found no adverse effects of seismic activity on movement or diving behaviour, although detecting subtle disturbance effects was limited. Stemp (1985) found no evidence of seismic effects on marine bird mortality or distributional effects in Davis Strait and Parsons (in Stemp 1985) reported shearwaters did not respond to seismic sources when in close proximity (30 m) to high frequency sounds. Additionally, Turnpenny and Nedwell (1994) found no ill effects of air source seismic surveys on guillemots, fulmars, and kittiwakes. Research in the Irish Sea also indicated no evidence seabirds were attracted or repelled by seismic activity (Evans *et al.* 1993).

Nonetheless, issues and concerns related to potential interactions between marine avifauna and seismic exploration surveys include:

- direct and indirect disturbances due to seismic noise;
- disturbance of vessel traffic noise and lighting; and
- oiling of birds due to vessel discharge or accidental equipment failure.

There have been few studies on the effects of air source -based seismic surveys on birds. However, there are no data showing that impacts exist. Offshore observers record sea bird sightings relative to the vessel, yet they have not reported any mortalities or injuries associated with the surveys. Shearwaters have been observed within 30 m of seismic array with their heads underwater and demonstrating no response (Stemp 1985). Because seismic pulses are directed downward and highly attenuated at the surface, near surface feeding and diving marine birds would not likely be exposed to sound

levels that would result in significant adverse effects on hearing or be life threatening. Above the water the sound is reduced to a muffled shot that should have little or no effect on birds that have their heads above water or are in flight. It is possible birds on the water at close range would be startled by the sound, however, the presence of the vessel and associated gear dragging in the water should have already warned the bird of unnatural visual and auditory stimuli. The only seabirds that may be affected at greater depths is the Alcidae family (Common Murre, *Uria aalge*; Thick-billed Murre, *Uria lomvia*; Razorbill, *Alca torda*; Dovekie, *Alle alle*; Black Guillemot, *Cephus grylle*; Atlantic Puffin, *Fratercula arctica*). These species dive from a resting position on the water in search of small fish and invertebrates and are capable of reaching great depths and spending considerable time underwater (Gaston and Jones 1998). The effects of underwater sound on *Alcidae* are not well known but sound is probably not important to *Alcidae* in securing food.

Temporary threshold shift (TTS) can last from minutes or hours to days. The magnitude of TTS depends on the duration and level of noise exposure (Davis *et al.* 1998). No studies have tested the level of sound necessary to cause TTS to marine birds, although TTS can occur in birds exposed to sound in air (Saunders and Dooling 1974). Seismic sounds are not continuous and the effects of intermittent pulse are not known. Corwin and Cotanche (1988) have shown that the auditory system of birds is able to recover from exposure to sounds.

Stemp (1985) found no evidence that a seismic program in the Davis Strait area had resulted in distributional effects on marine birds. Evans *et al.* (1993) noted that there was no evidence to suggest that seabirds were either attracted to or repelled by seismic testing in the Irish Sea. Turnpenny and Nedwell (1994) refer to data in which trained observers reported no behavioural effects on guillemot, fulmar and kittiwake species that were monitored during air source seismic surveys. Thus behavioural changes will likely not be evident for the bird species at risk in the Affected Area.

#### **6.1.4.2 Vessel Presence**

Seismic survey vessel traffic will be limited to routes to the survey area and the survey area itself. The closest Important Bird Area (IBA) to the seismic area of interest is Gros Morne National Park, which is located 30 to 42 km from the survey areas.

Avifauna species that occupy the Affected Area will likely not be disturbed by vessel activity due to its transitory nature. The area of interest for seismic surveys is offshore and, therefore is not expected to impact coastal breeding colonies, particularly the coast

and islands of Gros Morne National Park, an important breeding bird area for small numbers of Harlequin Ducks.

Birds attracted to vessel lighting at night, such as storm-petrels, may experience some disorientation and fly into vessel lights and other equipment. There is one extreme case of bird attraction where lights on a fishing vessel attracted 1.5 tonnes (6,000 birds) of crested auklets which endangered the vessel stability. The presence of the seismic vessel is a negligible addition of night lighting compared to fishing vessels and commercial traffic which transit through in the Project Activity Area year round. Collisions of migrating seabirds (*e.g.*, shearwaters, dovies, murrelets and Leach's storm-petrel) is one of an issue with erect structures such as lighthouses, broadcast and communication towers, illuminated office buildings, and offshore platform and light-induced fisheries (Gauthreaux and Belser 2006, Montevecchi 2006). Lighting is required for nighttime vessel activities, therefore navigation, deck lights and interior lights must be left on for safety. However, effort will be made to minimise operations that require high-intensity work lights. Such lighting may be turned off in inclement weather (low cloud cover, overcast skies, fog and drizzle conditions), if not required. Under foggy conditions, coastal lighting is more of an influence as birds fly closer to land (Chaffey 2003, Weir 1976, Blomqvist and Peterz 1984). Other light mitigation measures could include shielding upward projecting lights, turning off unneeded interior and exterior lighting and covering windows at night. Routine checks for and records of bird collisions and stranded birds will be reported and appropriate release of birds affected by light in the Project Area will be conducted.

Procedures for handling stranded birds will follow those outlined in the Storm Petrel Mitigation Program developed by Williams and Chardine (1999) for the Terra Nova Offshore Oil Development (Appendix A). An Environmental Observer will be assigned on the vessel during seismic surveys. All marine observations will be reported and information will be given to appropriate organizations to provide valuable information on the distribution of marine birds off the west coast of Newfoundland. A Live Seabird Salvage permit from CWS may be required for this Project (Appendix B)

#### **6.1.4.3 Vessel Discharge and Accidental Events**

Newfoundland has an unfortunate history of significant marine bird mortality associated mostly with ship source discharges. Accidental releases of hydrocarbons can expose birds to oil by breathing contaminated air, through skin contact, through eating contaminated prey items (Davies and Bell 1984), or by ingesting contaminants while preening contaminated plumage (Stout 1993). Exposure to hydrocarbons may result in a loss of waterproofing, thermoregulatory capability (hypothermia), and buoyancy

(drowning) due to the matting of feathers (Wiese 1999; MMS 2001). Oil ingestion, even in small amounts, may result in lethal and sublethal effects, including starvation due to increased energy needs to compensate for heat loss (MMS 2001). Potential impacts are expected to be limited due to the high volatility and relatively small volume of the spilled oil (diesel or kerosene). If a spill occurred and marine birds were impacted, the Williams and Chardine protocol (entitled "The Leach's Storm Petrel: General Information and Handling Instruction") or protocols recommended by the C-NLOPB for handling oiled or standard birds would be followed. No significant adverse effects are likely to occur as a result of an accidental event associated with this Project.

The impacts of oil on birds have been well documented (*e.g.*, Hartung 1995); however, no oil from discharge is expected to occur and thus, should not have any severe adverse effects of avifauna. Discharge from vessels will be standard for any marine vessel and will follow Offshore Waste Treatment Guidelines (OWTG) (NEB *et al.* 2003). Potential oil spillage may occur from ballast and bilge water discharge, however, if oil is suspected to be in the water, it will be tested and if necessary, treated using an oil/water separator to ensure that oil concentrations in the discharge do not exceed 15 mg/L as required by the MARPOL 73/78 (International Convention for the Prevention of Pollution from Ships 1972, and the Protocol of 1978 related thereto), International Maritime Organization and OWTG.

There will be limited amounts of marine fuel and lube oil onboard that could potentially be spilled into the ocean. Solid streamers are planned to use so the probability of streamer fluid incidents is nil. The potential for an oil pollution incident is low for this Project.

### **6.1.5 Cumulative Effects**

The cumulative effects of anthropogenic disturbance such as seismic surveys, oil and gas exploration, commercial fishing and shipping, along with natural process such as weather and food availability, have potential to change predator and prey abundances inside and outside the Affected Area, thus causing adverse negative effects of avifauna. However, the minimal increase in vessel traffic from this Project will be minor compared with existing vessel traffic in the area and should not significantly increase disruption to avifauna.

Routine discharges from marine vessels containing petroleum hydrocarbons could cumulatively influence avifauna. Although NWest is not directly responsible for other marine vessel discharges, seismic vessels used for this Project will comply with

discharge regulations established by OWTG and thus should not significantly add to short-term or long-term effects of oil spillage on marine avifauna.

Overall, there are no cumulative effects of this seismic exploration Project expected to occur on the distribution, abundance, breeding status and general well-being of marine avifauna inside and outside the Project Area.

### 6.1.6 Monitoring and Follow-up

An Environmental Observer will be onboard to record marine bird (and marine mammals) sightings during the program. The protocol will follow CWS's Standardized Protocols For Pelagic Seabirds Surveys From Moving and Stationary Platforms for the Hydrocarbon Industry: Interim Protocol - June 2005 (Appendix C).

### 6.1.7 Summary

Table 6.1 provides a summary of the potential for interaction, impact analysis, mitigations and cumulative and residual effects for marine and migratory birds.

**Table 6.1 Summary of Environmental Assessment for Marine and Migratory Birds**

<b>Interactions and Issues</b>	
<ul style="list-style-type: none"> <li>▪ Direct physical effects associated with seismic noise (<i>e.g.</i>, auditory damage)</li> <li>▪ Decline in prey availability</li> <li>▪ Disturbance from vessel noise and lights</li> <li>▪ Accidental spills causing oiling of birds</li> </ul>	
<b>Impact Analysis</b>	
There are no documented adverse effects directly on seabirds as reported by offshore observers. Effects associated with vessel presence and lights will be similar to what marine bird are exposed to now with the considerable commercial and fishing vessel traffic. Harlequin Ducks will not interact with the Project activities spatially, and are only at risk to a spill which would dissipate well within the distance of the Project Area to the coastline. Environmental effects including cumulative effects on marine and migratory birds is considered non-significant.	
<b>Mitigation</b>	
<ul style="list-style-type: none"> <li>▪ A dedicated observer will be on board the seismic vessel to record marine birds and incidents of collisions and strandings.</li> <li>▪ Vessel compliant with audit prior to survey.</li> <li>▪ Maintenance of streamer equipment and responsible management of such equipment.</li> <li>▪ Compliance with OWTG (NEB <i>et al.</i> 2002) and MARPOL for all discharges.</li> <li>▪ Avoidance of bird colonies in Gros Morne National Park by vessel.</li> </ul>	
<b>Significance</b>	
Likelihood of occurrence	Likely for survey Unlikely for spills

**Table 6.1 Summary of Environmental Assessment for Marine and Migratory Birds**

Geographic extent	Immediate, local to vessel
Frequency of occurrence	Intermittent for 20-30 days or up to 75 days for 3D program Intermittent for one week for well site survey Continuous for hours for VSP
Duration of impact	Immediate
Magnitude of impact	Negligible or seismic Low for spills
Reversibility	Reversible
Significance of Effects	Not adversely significant
<b>Confidence</b>	
<ul style="list-style-type: none"> <li>• High level of confidence based on previous seismic surveys and research.</li> </ul>	

## **6.2 Marine Fish and Shellfish**

Marine fish are an important component of the marine ecosystem and play a significant role in the stability of commercial fisheries. Environmental effects on the marine fish community may affect commercial fisheries and other ecosystem components that rely on several species of marine fish as a food source or conversely, be affected by predation. This analysis considers Project interactions with commercial pelagic and demersal fish and invertebrates, including egg, larval, juvenile and adult life stages. Fish spawning is of critical importance as survivability of fish at early life stages may be a major limiting factor on adult populations.

### **6.2.1 Boundaries**

The spatial boundaries of interaction between marine fish and shellfish and the Project are primarily related to the predicted zone of influence of noise attenuation from the seismic array. In the vertical orientation, the sound level will exceed background to the seafloor in the Project Area because the seismic energy is directed at the seafloor. In the horizontal plane, the sound levels will exceed typical background levels (90 to 120 db re 1  $\mu$ Pa) at 30 to 50 km from the source. Ecological boundaries vary depending on the distribution, spawning and migration patterns of the adult fish, and the presence of fish eggs and larvae.

With respect to temporal boundaries, the potential interactions of concern are those related to the seismic activities that could occur in August to October in 2008 for Seismic Survey Option 2.1 and between May to December in subsequent years until 2015. Although exact timing of potential surveys is not known at this time, consultations with

fishers will continue on an annual basis to establish a suitable seismic surveys window to minimise conflicts.

With regard to administrative boundaries, DFO manages the fisheries resources in the area and is primarily responsible for scientific surveys within the area. The Project Area is included in two NAFO Unit Areas, 4Rb and 4Rc.

The technical boundaries and the information available for this study rely on existing information with regard to marine fish/shellfish distribution, migration and spawning areas. There is a lack of precise spatial information on spawning grounds, particularly as related to non-commercial species. Other uncertainties surround some demersal fish species, which continue to decline despite moratoriums and controls on fishing effort. There are also few specific studies on the physical effects of seismic studies on fish spawning specific to the Affected and Regional Areas.

### **6.2.2 Potential Interactions and Issues**

Potential interactions between the Project and marine fish and shellfish relate primarily to direct physical injury and detrimental behavioural effects as a result of noise from seismic activities. Physical injury may include failure to reach the next development stage, hearing injury and death to:

- fish eggs and larvae;
- juvenile and adult finfish; and
- invertebrates.

Behavioural effects may include:

- avoidance behaviour;
- increased swimming speeds;
- disruption of migration patterns; and
- disruption of reproductive behaviour and success.

Acoustic behaviour and uses of sound by fish are less documented than the physiology of sound detection by fishes. The effects of intense and potential harmful sound on fish hearing and behaviour are poorly understood. Such noise may disturb fish and may produce temporary or permanent hearing impairment in some individuals, but is unlikely to cause death or life-threatening injury.



### **6.2.3 Significance Criteria and Evaluation**

A significant adverse environmental effect is one that is likely to cause one or more of the following:

- mortality or life-threatening injury to individuals of a species at risk;
- the abundance of one or more non-listed species is reduced to a level from which recovery of the population is uncertain;
- long-term or permanent displacement of any species from spawning habitat; or
- destruction or adverse changes to critical or essential fish habitats.

To be considered significant, Project-related mortality would exceed the range of natural mortality by two standard deviations.

A non-significant adverse environmental effect is one that is likely to cause one or more of the following:

- mortality or life-threatening injury of individuals (other than listed species) in small numbers that would not adversely effect the population or the ecological functioning of the fish community; and or
- short term displacement of individuals from preferred feeding, spawning, nursery grounds or migratory routes (including critical habitat for listed species and essential fish habitat)

### **6.2.4 Effects Assessment and Mitigation**

#### **6.2.4.1 Physical Effects**

Most studies on the biological effects of seismic sound energy have concentrated on marine mammals and fish, groups which have sensitive hearing organs and which, in many cases, incorporate sound as part of social behaviour. Therefore, this section will discuss effects on fish hearing, physical and anatomical effects, auditory masking and behavioural effects as they may affect spawning fish and eggs and larvae.

#### **Fish Hearing**

Fish hear in two modes. The stimulation mode is acoustic particle motion or hydrodynamic motion accelerating fish soft tissues, including sensory epithelium with

the surrounding water. In this mode, sound pressure does not play a direct role and species that hear exclusively in this mode are hearing generalists. The other mode is through the swimbladder or other gas bubble linked to fluid systems in the ear and subsequently to the otoliths. This mode makes fish sensitive to sound pressure, with best thresholds of 50 dB re 1  $\mu$ Pa and hear in a range from <100 to 3,000 Hz, with optimal range between 200 and 1,000 Hz. Sensitivity to sound depends on sound duration, level of ambient noise in the frequency range of the signals and on the physiological integrity of the auditory system.

The sounds produced by air sources are impulsive, damped sinusoids and in the frequency range between 10 and 200 Hz. The air sources will be audible by all fishes as hearing frequencies of fish in the Affected Area are within or above this range. Therefore, spawning fish will hear the air sources from this Project.

Invertebrates, on the other hand, have been little studied in terms of bioacoustics and there is a paucity of information relating to the effects on them of seismic sound waves. Some crustacean species generate low frequency sounds which presumably serve a communicatory function, for example, the spiny lobsters (*Palinuridae*) and the snapping shrimps (*Alpheidae*). Because invertebrates lack air-filled cavities, it is almost certain that they would respond to the particle motion component of sound rather than to sound pressure, and as a consequence their sensitivity to sound is likely to be inferior to that of fish. Crustaceans have a variety of hair-like sense organs that are potentially capable of responding to mechanical stimuli, including sound, but similar structures have not been identified in bivalve and gastropod molluscs. These mollusc groups are therefore unlikely to change their behaviour in response to seismic sound waves, although they could show physiological reactions and anatomical damage. The highly mobile predatory cephalopod molluscs (squid, octopus) are thought to be insensitive to sound.

The subject of acoustic detection in decapod crustaceans has been previously investigated over the past few decades to estimate invertebrate response to sound and vibration (Popper *et al.* 2001). Decapods have surface hair-like cells that serve as chemoreceptors and mechanoreceptors to detect water flow and vibrational stimuli and they respond to frequencies up to 100 Hz with a single spike per cycle. Chorodental organs, associated with flexible body appendages, signal joint position, movement and stress and they respond to low-frequency waterborne vibrations. Statocysts are located on the basal segment of each antennule in crabs and other body areas in other crustaceans are involved in maintaining equilibrium. They are unlikely to respond to acoustic stimulation. Norway lobster (*Nephrops norvegicus*) showed postural responses to sound frequencies of 20 to 180 Hz in the lab (Goodall *et al.* 1990). In the field the response was due to particle displacement and not pressure. Responses were analogous

to fish lateral line which response to water motions produced within a fish-length of the detecting animal (Popper *et al.* 2001).

### **Physical and Anatomical Effects on Fish and Shellfish**

Numerous studies have been conducted on fish mortality as a result of exposure to seismic sources (*i.e.*, Falk and Lawrence 1973; Holliday *et al.* 1987; La Bella *et al.* 1996; Santulli *et al.* 1999; McCauley *et al.* 2000a, 2000b; 2003; Thomsen 2002; IMG 2002; Hassel *et al.* 2003). Mortality of fish did not occur in any of these studies. Rise times are too slow and peak pressures too low to cause serious injury, except perhaps to fish that are within a few metres of an air sleeve at the time of discharge (Turnpenny and Nedwell 1994). DFO (2004c) concludes that there are no documented cases of fish mortality upon exposure to seismic sound under field conditions and that exposure to seismic sound is unlikely to result in direct fish mortality. Therefore, spawning fish are not likely to be mortally impacted by air guns from this Project.

A typical well site survey could have a peak pressure output of 230 dB re 1  $\mu$ Pa @ 1 m (Davis *et al.* 1998), with a single streamer array. Data on the impacts of seismic surveys on macroinvertebrates is sparse, but what little research data that exists suggest that mortality through physical harm is unlikely below sound levels of 220 dB re 1  $\mu$ Pa @ 1 m (Royal Society of Canada 2004). Invertebrates lack swim bladders and hearing organs, two anatomical features where physical damage most likely occurs in aquatic organisms. The Royal Society of Canada (2004) suggests that seismic surveys will have no effect on the marine benthos provided the water depth is greater than 20 m.

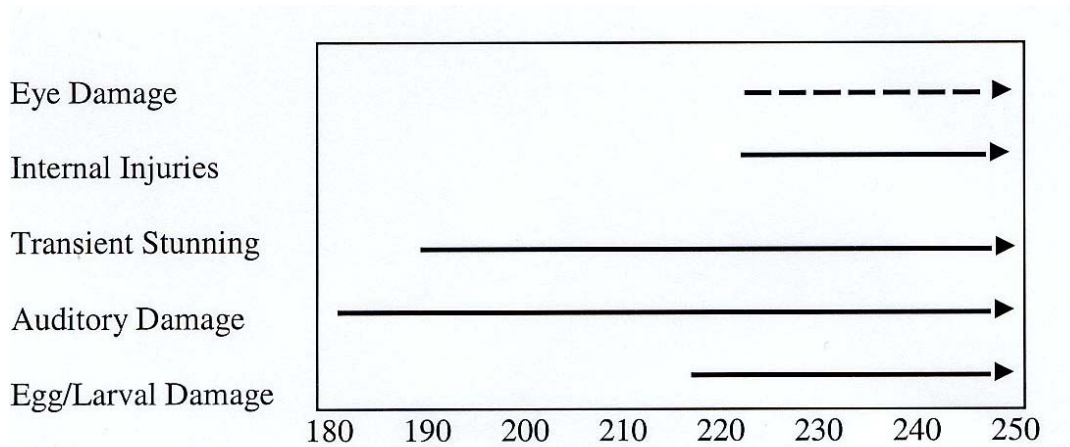
The energy levels emitted from the VSP will be considerably less in source (760 cu. in.) and slightly less in output (242 dB re 1  $\mu$ Pa at 1 m) than typical for 2D or 3D seismic programs (3,000 to 5,000 cu. in. air source s and about 255 dB re 1  $\mu$ Pa at 1 m). The U.S. Minerals Management Service's environmental assessment of geophysical exploration in the Gulf of Mexico supports the conclusion that there is no documented evidence of a measurable impact to benthic communities from streamer surveys, VSP surveys or remote sensing surveys (MMS 2004a).

In adult fish, pressure differentials can cause damage to the swimbladder within several metres of an air sleeve (Turnpenny and Nedwell 1994). Evidence of damage to the inner ear was apparent in cod and goldfish (*Carassius auratus*) at exposures of 180 dB re 1  $\mu$ Pa and 182 to 204 dB re 1  $\mu$ Pa of pure tones, respectively. Damage to fish ear structures from exposure to seismic air sleeves has been documented (McCauley *et al.* 2000a; 2000b, 2003; Enger 1981). However, the experimental fish were caged and exposed to high cumulative levels of seismic energy that would not likely occur under normal seismic operations due to avoidance behaviour of uncaged fish. Pressure waves can result in a

reduction in hearing sensitivity, referred to as a temporary threshold shift (TTS). Studies have shown that exposure to intense sound can affect the auditory thresholds of fish resulting in TTS under certain conditions (*i.e.*, Amoser and Ladich 2003; Smith *et al.* 2004). However, these studies focused on captive fish that were exposed to loud (158 dB re 1  $\mu$ Pa) noise for periods of 10 minutes for 12 or 24 hours. TTS may seldom (or never) occur in the wild unless fish are prevented from fleeing the irritant (Amoser and Ladich 2003). This anatomical damage to the ears is expected to cause elevated sound detection threshold and the defects would be expected to last for the period of time that the tissue damage occurred. Increased thresholds would be expected to occur for sounds in the frequency range served by the lesioned areas, but not necessarily for sounds of other frequencies. Hair cells can regenerate in fishes at about 7 days post trauma, damage-induced threshold shifts may not be permanent, but last only 1 to 2 weeks.

Kosheleva (1992) reports no obvious physiological effects beyond 1 m from a source of 220 to 240 dB re 1  $\mu$ Pa. He tested external damage, and reported no visible signs of damage on crabs exposed to a gun at 0.5 m.

Hastings (1990) reports the lethal threshold for fish beginning at 229 dB re 1  $\mu$ Pa and a stunning effect in the 192 to 198 dB re 1  $\mu$ Pa range. Turnpenny and Nedwell (1994) deduce that blindness can be caused in fish exposed to air sleeve blasts on the order of 214 dB re 1  $\mu$ Pa; auditory damage starts at 180 dB, transient stunning at 192 dB re 1  $\mu$ Pa and internal injuries at 220 dB re 1  $\mu$ Pa (Figure 6.1).



**Figure 6.1** Sound Pressure Threshold (dB re 1  $\mu$ Pa) for the Onset of Fish Injuries

Source: adapted from Turnpenny and Nedwell 1994.  
 Note: Dotted line indicates an assumed sound level.

The lowest levels causing documented damage are 180 dB for continuous, long duration tones in a region of good hearing (200 to 500 Hz). The effects of intermittent sound stimulation are not known, but 20% duty cycle is less effective in damaging hair cells than continuous sounds. Most fish exposed to air gun source points at a distance of a few metres could suffer inner ear damage at a source range of 210 and 240 dB. For this Project 3-D/2-D array, this sound level is 1 metre or less from the array, depending on angle of emission. The probability of hearing impairment decreases with increased distance between the fish and air gun sources as sound attenuates.

Christian *et al.* (2004) used a variety of chemical and biochemical indicators in the haemolymph and serum of crustaceans to detect stress or dysfunction when exposed to air gun arrays. When exposed to a 40 cu. in. sleeve gun at 2 m, a 200 cu. in. array at 4 m, and a 200 cu. in. seven gun array at 2 m, Christian *et al.* (2004) found no significant differences to crustacean physiology between control and experimental groups. Furthermore, Christian *et al.* (2003) did not find any discernible signs of external damage (*i.e.*, carapace, appendages, statocysts) as a result of exposure to the guns and arrays. DFO (2004d) conducted a field survey, in winter 2003 and spring 2004, on potential impact of low-level seismic energy on the reproductive biology of female snow crab. The survey used caged animals off the western coast of Cape Breton, as well as laboratory experiments. As with other studies, mortality did not occur in any crabs during experimental conditions (Kosheleva 1992, Christian *et al.* 2004, DFO 2004d); survival of the embryos and locomotion of the resulting larvae after hatch were unaffected; and gills, antennae and statocysts were soiled in the test group, but were found free of sediment five months later. Less definitive results were significant differences between test and control groups related to bruising of the hepatopancreas; bruising of ovaries; dilated oocytes with detached chorions; one test group had delayed embryo hatch and larvae were slightly smaller; and orientation as a function of being turned over (DFO 2004d).

Increased stress as a response to external factors is generally difficult to measure in invertebrates. However, changes in relative movement when exposed to a sound field may be a good indicator of stress. Christian *et al.* (2004) discuss the startle responses observed by snow crabs held in a DFO tank and exposed to sounds produced by the clanging of metal bars. Snow crabs were observed immediately drawing in their legs and proceeding to escape the region of the imposing sound. When exposed to a 200-cu. in. array located at a distance of 50 m, caged as well as tagged snow crab demonstrated little to no movement; they did not draw in their legs, and they remained in their original position (Christian *et al.* 2004). Thus, seismic sound fields are not anticipated to cause adverse effects by increasing stress on snow crabs.

In response to concerns for seismic surveys in shallow water on the west coast of Newfoundland, Payne *et al.* (2007) were funded to conduct laboratory and field experimentations on lobsters subject to seismic sources. One set of laboratory exposure set up was with a 10 cu. in. air sleeve in an aquarium (3.6 m x 2.4 m x 1.3 m). Field exposures were set to have a gun lowered to 2 m depth and lobsters positioned below in a cage at 4 m depth. The endpoints measurements were lobster survival, food consumption, turnover rate, serum protein, serum enzymes, serum calcium and a histopathology examination. The authors caution, and rightly so, that the studies are exploratory and must not be over interpreted. Firstly, seismic vessels nor the towed array can not operate in such shallow water due to draft limitations, thus lobsters would not be exposed to this extent. Goodall *et al.* (1990) emphasised the importance of measuring the responses under appropriate acoustical conditions, and not in small tanks where boundaries result in reflections and distort relationships between sound pressure and particle velocity (Parvulescu 1964). To make a real determination of the nature of a response, the experiments must be conducted in the field, or under carefully controlled semi-natural laboratory conditions (Popper *et al.* 2001). Over a period of days to several months, there were no effects of delayed mortality or damage to mechanosensory systems associated with animal equilibrium and posture. There as no evidence of leg loss or other appendages. Sublethal effects were observed with feeding (minor) and serum biochemistry and organ stress was apparent in the hepatopancreas.

No significant adverse effects of seismic noise on the behaviour, physiology or catch rates of snow crabs or lobsters are anticipated from the 3-D/2-D seismic surveys, well site surveys or VSP surveys.

### **Auditory Masking**

The potential effect that seismic activities may have on masking communications by fishes is not well documented. There is overlap in the frequency of seismic signals and the sounds emitted by fish, so there is potential for sound reception and production in fish to be reduced (Myrberg 1980). Acoustic communication is important during cod spawning. Sound recordings at the major spawning ground off the Lofoten Islands, Norway revealed a hushed hubbub of sound, at approximately 40 to 500 Hz during the spawning period. Recent experiments on goldfish indicate that fish are capable of “auditory scene analysis”, meaning that a sound stream of interest can be “heard out” and analyzed for its informational content independently of simultaneous, potentially interfering sounds (Fay 1998, in MMS 2004). These studies were carried out using repetitive impulses or clicks as signals and as potentially interfering sounds. These results suggest that the presence of intermittent, audible air sleeve source points would not necessarily impair fishes in receiving and appropriately interpreting other

biologically relevant sounds from the environment (MMS 2004). The 3-D/2-D seismic surveys, well site surveys and VSP surveys are unlikely to result in population level effects on fish spawning.

#### 6.2.4.2 Behavioural Effects

There have been no published reports on the effects of hearing impairment or excessive masking on the acoustic communication behaviour of any fish species. These behaviours include startle responses to predators, courtship and mate choice, maintenance of schooling and aggregation, aggressive competition for mates and other resources, and overhearing or intercepting potential predators, prey, and competitors.

There are well documented observations of fish and invertebrates exhibiting behaviours that appeared to be in response to exposure to seismic activity like a startle response, a change in swimming direction and speed, or a change in vertical distribution (Hassel *et al.* 2003; Wardle *et al.* 2001; McCauley *et al.* 2000a; 2000b; Pearson *et al.* 1992; Schwarz and Greer 1984; Blaxter *et al.* 1981) although the significance of these behaviours is unclear. The effects of nearby air sleeve operations on fish as determined from several studies, are summarized in Table 6.2.

**Table 6.2 Summary of Behavioural Effects of Fish and Invertebrates from Nearby Air Sleeve Operations**

Reference	Level (dB re 1 µPa (rms))	Species	Effects
McCauley <i>et al.</i> (2000a,b)	156-161	Various fishes	Common 'alarm' behaviour of forming 'huddle' on cage bottom centre, noticeable increase in alarm behaviours begins at lower level
Pearson <i>et al.</i> (1992)	<sup>a</sup> 149	rockfish ( <i>Sebastes</i> spp.)	Subtle behavioural changes commence
Pearson <i>et al.</i> (1992)	<sup>a</sup> 168	rockfish	Alarm response significant
McCauley <i>et al.</i> (2000a,b)	>171	fish ear model	Rapid increase in hearing stimulus begins
McCauley <i>et al.</i> (2000a,b)	182-195	fish ( <i>P. sexlineatus</i> )	Persistent C-turn startle
Pearson <i>et al.</i> (1992)	100-205	selected rockfish species	C-turn startle response elicited
Wardle <i>et al.</i> (2001)	<sup>b</sup> 183-207	various wild finfish	C-turn startle responses
McCauley <i>et al.</i> (2000a,b)	146-195	various finfish	No significant physiological stress increase

**Table 6.2 Summary of Behavioural Effects of Fish and Invertebrates from Nearby Air Sleeve Operations**

Reference	Level (dB re 1 $\mu$ Pa (rms))	Species	Effects
McCauley <i>et al.</i> (2000a,b)	174	Squid ( <i>Sepioteuthis australis</i> )	Startle (ink sac fire) and avoidance to startup nearby
McCauley <i>et al.</i> (2000a,b)	156-161	Squid	Noticeable increase in alarm behaviours
McCauley <i>et al.</i> (2000a,b)	166	Squid	Significant alteration in swimming speed patterns, possible use of sound shadow near water surface

Source: adapted from McCauley *et al.* 2000a; 2000b.

<sup>a</sup> - converted from mean peak to rms using -12 dB correction from 7,712 records from Bolt 600B air-sleeve.

<sup>b</sup> - correction of -12dB applied (peak to rms).

Some studies indicate that such behavioural changes are very temporary while others imply that marine animals might not resume pre-seismic behaviours or distributions for several days (Engås *et al.* 1996; Løkkeborg 1991; Skalski *et al.* 1992).

Fish startle by sudden changes in noise levels, but seem to acclimate to “ambient noise”. Noise generated by seismic activity may cause some species to avoid the zone of influence around the seismic vessel. Studies note that many species of fish dive to avoid intense sound (Protasov 1966; Schwartz and Greer 1984; Knudsen *et al.* 1992). Blaxter *et al.* (1981) found that schooling herring changed direction with a sudden noise level of 144 dB re 1  $\mu$ Pa and when ramping up occurred, they reacted to a noise level around 5 dB higher. Turnpenny and Nedwell (1994) investigated information from power station trials and found that air source signals ranging from 160 to 186 dB re 1  $\mu$ Pa resulted in avoidance behaviour. In one trial, Løkkeborg and Soldal (1993) estimated that avoidance behaviour in fish occurs between 160 and 171 dB re 1  $\mu$ Pa. McCauley *et al.* (2000) conducted trials with captive fish and found that increases in swimming behaviour occurred when seismic sound levels reached 156 dB re 1  $\mu$ Pa. In 40 m of water, this sound level could occur at 500 m to 32 km from that array at an emission angle of 0 °and 45° respectively. In 350 m of water, this sound level could occur at 128 m to 32 km from that array at an emission angle of 0 °and 45° respectively.

The expected distance for fish to react to a typical peak source level of 250 to 255 dB re 1  $\mu$ Pa is from 3 to 10 km (Engås *et al.* 1996). A reaction may simply mean a change in swimming direction. The spatial range of response in fish will vary greatly with changes in the physical environment in which the sounds are emitted. In one environment, fish distribution has been shown to change in an area of 40 x 40 nautical



miles and 250 to 280 m deep for more than five days after recording ended, with fish larger than 60 cm being affected to a greater extent than smaller fish (Engås *et al.* 1996). McCauley *et al.* (2000 a, b) describes a more intense “generic” fish alarm startle response of seeking shelter in tight schools and moving near the bottom. The level that will induce this response varies with fish species and the physical environment at the time but was observed at 156 to 168 dB re 1 µPa. Noise levels will attenuate to ambient levels 30 to 50 km from the survey vessel. To minimise sudden changes in noise levels, NWest’s Contractor will implement a ramp-up procedure.

The Science Review Working Group (CNSOPB), which evaluated two proposed seismic surveys near Cape Breton, agreed that although the duration of behavioural effects of seismic activity on marine fish are uncertain, indications exists, as described in above studies, that displacement of marine fish is short-term. The ramping up procedure in this survey will give fish an opportunity to temporarily leave the areas while noise levels are above ambient. DFO (2004c) concluded that some fish exposed to seismic sounds are likely to exhibit a startle response, a change in swimming pattern and/or a change in vertical distribution. However, these effects are expected to be short term and of low ecological significance except where fish reproductive activity may be affected (DFO 2004c). Although there is no evidence of an adverse impact of seismic activity on the spawning success of fish, there is sufficient concern to suggest that a precautionary approach to the use of this equipment at these times is adopted.

#### **6.2.4.3 Eggs and Larvae Development**

While it is recognized that fish eggs, zooplankton (including ichthyoplankton) and larvae could be killed or damaged at distances up to or less than five metres from a large array, various studies have indicated that the impact would be indistinguishable from natural mortality, given the extent of exposure and the numbers of organisms involved.

Sætre and Ona (1996), in a worst-case risk analysis, estimated the total mortality from a typical 3-D seismic survey (conducted in a tight, close grid over a relatively small area) on a typical larval population in the North Sea and calculated an effective mortality radius. Their results indicated that the maximum population mortality from a large 3D seismic survey would be just 0.45% of the fish larvae, or 0.18% of the total population in the area per day. Since natural mortality for eggs and larvae is estimated at 5 to 15%/day, the effects of the array on fish larvae would be impossible to differentiate from natural mortality, and well within natural variability.

Reporting on a workshop of oil industry, DFO and fisheries participants from Nova Scotia and Newfoundland sponsored by ESRF in Halifax in 2000, LGL-Griffiths Muecke (Thomson *et al.* 2001) noted that, in light of such information, "The workshop participants concurred that studies of seismic effects on fish eggs and larvae were of low priority and were not considered further" (p. vii).

Early life stages of invertebrates are generally the most sensitive to disturbance and other external factors potentially causing harmful effects. Effects on embryonic growth may result in loss of overall fitness of the snow crab population by delaying development and hatching out of normal phase, increasing susceptibility of predation, increasing mortality, *etc.* Most scientific evidence, however, is limited to fish and other vertebrate species. Christian *et al.* (2004) performed experiments on fertilized eggs, which indicated statistically significant differences. Mortality was demonstrated to be 1.6% higher in 2,000+ eggs when compared with controls. However, the exposure distance remained constant at 2 m, and Christian *et al.* (2004) discuss the limitations involved in using one pool of control eggs and one pool of exposed eggs. The authors caution that their study was a preliminary investigation and further research may be needed to confirm a safe exposure distance.

Previous studies have demonstrated that crustaceans may only be in the range of pulse perception within 20 m (McCauley *et al.* 2000). Davis *et al.* (1998) concluded that direct physical effects on larvae are negligible based on studies that have demonstrated exposure to sound fields (*i.e.*, 231 dB re 1 $\mu$ Pa exposed to stage II zoeae) did not affect survival and development (Davis *et al.* 1998, Pearson *et al.* 1994). Furthermore, Pearson *et al.* (1994) exposed Dungeness crab larvae to 231 dB re 1 $\mu$ Pa and concluded that survival, development, and behaviour were not impacted.

Snow crab populations in natural conditions are not likely to be found within the close distances to a seismic array that would be needed to cause developmental delays and increased mortality rates. Eggs are held by female snow crabs (Christian *et al.* 2004), and would be situated well beyond 20 m. Although the exact optimal and minimum distance is not known to ensure egg development will not be impacted by seismic arrays, the current survey distances are considered to be at a safe distance to ensure significant adverse impacts do not occur.

Mitigation measures will comply with the *Statement of Canadian Practice on Mitigation of Seismic Noise in the Marine Environment* and C-NLOPB's *Mitigation and Operating Conditions*, to the extent reasonably practical.

Mitigation measures to minimize the impact of seismic operations on fish spawning include:

- Efforts will be made to avoid all known spawning areas at times when fish are likely to be spawning; Figure 5.21 shows known spawning areas for cod which is south of the NWest leases. Cod spawn in the early spring (April to May).
- To minimize sudden changes in noise levels, a ramp up procedure will be implemented;
- All discharges will comply with *Offshore Waste Treatment Guidelines*;
- Spill prevention will be implemented; and
- An Emergency Spill Response Plan will be developed and implemented when required.

No significant adverse effects on fish, lobsters, snow crab or eggs and larvae are anticipated as a result of NWest's 3-D/2-D seismic program, well site survey or VSPs. No specific mitigation is proposed during routine seismic activities.

#### **6.2.4.4 Accidental Events**

Oil or kerosene spills may affect water quality, which in turn may affect the health and survival of plankton, fish eggs, and larvae, juvenile and adult fish in the immediate vicinity of the vessel. While risk to adult fish and shellfish is low, pelagic fish eggs and larvae may be affected to different degrees by an accidental spill of hydrocarbons in the water. The nature and degree of such an interaction depends on the severity, timing, and location of the spill. The risk of such vessel accidents is low, and the volumes potentially released are limited. Therefore, incidents involving survey vessels are not likely to result in significant effects on fish.

According to a literature review by Thomson *et al.* 2000, the sensitivity of fish larvae to an oil spill varies depending on the type of oil (*e.g.*, crude, light condensate, etc.), yolk sac stage, and feeding conditions. Spill investigations have focused on dramatic events from vessels or offshore platforms. The Argo Merchant spill of 7.7 million gallons of No. 6 fuel in December 1976 on Nantucket Shoals off Massachusetts affected some fish eggs. Some of the eggs collapsed or had malformed shells, while others had oil spots on the outer membrane. Eggs and larvae exposed to oil generally exhibit morphological malformations, genetic damage and reduced growth (Thomson *et al.* 2000). However, these effects are short lived since these changes are not observed in subsequent years at the same location. No conclusive evidence in the literature exists to suggest that these oiled sites posed a longterm hazard to fish embryo or larval survival. The Regional

Environmental Emergencies Team (REET) report on the Uniacke G-72 gas and condensate blowout concluded that there were no observed signs of long-term impacts on renewable resources or the marine environment around Sable Island from the blowout (Riley 1984). Although oil spills and blowouts can result in fish kills, neither event has been found to result in a decrease in fish stocks (Environment Canada 1984; Martec Limited 1984; Armstrong *et al.* 1995). In the NWest licences, the effects of an accidental spill from a leaking streamer on marine fish and pelagic invertebrates will not occur as solid streamers will be used.

### 6.3 Cumulative Effects

The main projects and activities that may interact cumulatively with fish spawning include oil and gas exploration and production activities, other seismic projects, commercial shipping traffic, commercial fishing, and commercial fishing traffic. Two seismic exploration projects will be active in the vicinity of the Project Area. PDI Productions Inc. is commencing work in the fall of 2007 in the Port au Port area (EL 1070) but if the Project undergoes unavoidable delays, the seismic work could be undertaken anytime in the next three years. Tekoil and Gas Corp. is conducting seismic work over part of, and adjacent to, the Port au Port Peninsula (EL 1071) during a six-week period from October 2008 to April 2009. The location of these two surveys are in the same location and are 68.5 km south the most southern boundary of the Project Area and 143 km from Seismic Survey Area Option 2.1. There will be no spatial or temporal overlap between these projects and the NWest Project.

In addition to these human activities, marine fish populations in the Affected Area may be affected by natural factors, such as changes in prey and predator populations in areas within their natural range that may occur outside the Affected Area. Certain populations of marine fish are more vulnerable to changes in their environment. This is especially true of species at risk. This seismic program is not changing critical or preferred habitats of marine fish, nor resulting in mass removal of these species. The distribution of most fish species varies seasonally in response to physical or chemical changes in the surrounding environment (*e.g.*, depth, substrate, salinity, temperature) and as a result of seasonal habitat requirements (*e.g.*, spawning, feeding).

Long annual migrations are undertaken by most pelagic species, such as herring and mackerel, and groundfish species, such as cod. The Project will not change the physical or chemical requirements that dictate fish presence, and their ability to reproduce.

Although non-significant, the residual effects of the Project components on fish spawning that may be cumulative with the effects of other human activities in the region

are expected to be very limited, consisting primarily of short-term avoidance behaviour. The predicted cumulative effects of the proposed seismic survey with other seismic projects, noise from vessel traffic, the presence of offshore oil and gas structures, and commercial fishing are likely similar to those discussed in the assessment above. Seismic surveys produce repetitive, localised and short-term increases in ambient noise levels, with the period between potential exposures ranging from hours to days. Within the near field of an array, about 300 m, received noise levels may reach or exceed 180 dB re 1  $\mu$ Pa. Beyond this distance, sound from a seismic survey is similar to commercial vessels (MMS 2004). Given the existing and future seismic survey activity, the incremental sound made by supply boats, fishing vessels, and commercial vessel traffic will not add significantly to existing ambient noise levels in the Affected Area.

If another seismic survey being conducted on the western shelf within the proposed timeframe, a significant distance between surveys will be necessary to prevent both operational conflict and acoustical interference. For instance, most survey operators indicate that they aim to maintain a minimum distance of 40 to 50 km from any other survey vessels, and separation for concurrent surveys is typically greater than 50 km. In the normal course of survey operations, seismic vessel operators, working in a similar geographical area, will plan operations to maximize separation and thereby reduce or avoid seismic interference. This will reduce or eliminate the likelihood that the sound levels from two surveys will be additive in a particular area, and reduce the potential for cumulative effects on marine fish and shellfish.

Considering the significance criteria provided for fish and given that impacts from cumulative vessel traffic, individual projects and other activities in the Affected Area are not likely to contribute to significant adverse effects. The Project components are predicted to have minimal interaction with species at risk, the 3-D/2-D seismic surveys, well site surveys and VSP surveys are not anticipated to result in significant cumulative adverse effects to marine fish and shellfish.

The main cumulative impact on snow crab population is the fishing activities for snow crabs potentially occurring at the same time as the seismic exploration. A smaller number of surveys are anticipated over the eight-year period (2008 to 2015), compared to the number of fishing activities occurring for snow crabs. Christian *et al.* (2004) found that post-seismic catches were higher than pre-seismic catches, although this trend is likely unrelated to seismic operations. In general, the cumulative effect on snow crab populations is short-term and localized and not significant to the overall well-being of the invertebrate species. The proposed Project components are not expected to result in or contribute to any significant cumulative impacts on snow crab populations. Seismic

surveys (2-D) have been undertaken in the Regional Area with no apparent effects to fish or fisheries success.

### 6.3.1 Monitoring

Follow-up and monitoring are not recommended for fish and shellfish for routine seismic activities.

### 6.3.2 Summary

Table 6.3 provides a summary of the potential for interaction, impact analysis, mitigations and cumulative and residual effects for marine fish and shellfish.

**Table 6.3 Summary of Environmental Assessment for Marine Fish and Shellfish**

<p><b>Interactions and Issues</b></p> <ul style="list-style-type: none"> <li>▪ Behavioural changes</li> <li>▪ Physiological changes</li> <li>▪ Masking of sound</li> <li>▪ Hearing impairment</li> <li>▪ Mortality</li> </ul>
<p><b>Impact Analysis</b></p> <p>Noise levels from geophysical activities and vessel traffic for this Project are predicted to be less than the limits that cause physical effects on fish. Turnpenny and Nedwell (1994) summarized the following physical effects of noise on fish (worse case within 10 m of a 255 db re 1 µPa source):</p> <ul style="list-style-type: none"> <li>▪ transient stunning of marine fish occurs at noise levels above 192 dB re 1µPa;</li> <li>▪ internal injuries at 200 dB re 1µPa;</li> <li>▪ egg/larval damage due to noise occurs at 220 dB re 1 µPa; and</li> <li>▪ fish mortality at 230-240 db re 1µPa.</li> </ul> <p>McCauley <i>et al.</i> (2000) conducted trials with captive fish and found that increases in swimming behaviour occurred when seismic sound levels reached 156 dB re 1 µPa. In the survey proposed by NWest, sound is estimated to attenuate to 156 dB re 1 µPa @ 1 m at a distance of 32 m -500 m at 0° below horizon and 812 m-32 km at 45° emission angle in 40 m of water. In 150 m water depth, the distance to the same attenuation is 32 m-128 m at 0°, 32 m at 10°, and 2-32 km at 45° emission angles. Noise levels should attenuate to ambient levels 30 to 50 km from the survey vessel. To minimise sudden changes in noise levels, NWest will implement a ramp-up procedure.</p> <p>The various components and activities associated with the proposed Project are not predicted to result in significant environmental effects on fish and shellfish because the effects are reversible, of limited duration, magnitude, and geographic extent (Table 5.2). Although there are few studies on the effects of seismic surveys on specific fish species in the Gulf of St. Lawrence, research studies show that mortality or serious injury is unlikely beyond a distance of approximately 2 m from the sound source. Effects of the Project on marine fish and shellfish in the Affected Area are predicted to be non-significant.</p>
<p><b>Mitigation</b></p> <ul style="list-style-type: none"> <li>▪ Adherence to the <i>Statement of Canadian Practice on the Mitigation of Seismic Noise in the Marine Environment</i>, to the extent reasonably practical.</li> <li>▪ To minimize sudden changes in noise levels, a 30 minute ramp up procedure will be implemented.</li> </ul>

**Table 6.3 Summary of Environmental Assessment for Marine Fish and Shellfish**

<ul style="list-style-type: none"> <li>▪ Avoidance of known spawning areas at times when fish are known to be spawning, where appropriate.</li> <li>▪ Compliance with OWTG (NEB <i>et al.</i> 2002) for all discharges.</li> </ul>	
<b>Significance evaluation</b>	
Likelihood of occurrence	High for behaviour level effects to finfish, Low for shellfish and finfish physical effects.
Geographic extent	Immediate for physical effects Local to Regional for behaviour effects
Frequency of occurrence	Intermittent during 3-D data acquisition (20-30 days or up to 75 days) Intermittent for one week for well site survey Continuous for hours for VSP
Duration of impact	Immediate
Magnitude of impact	Low
Permanence/reversibility	Reversible
Significance of effect	Not adversely significant
<b>Confidence</b>	
<ul style="list-style-type: none"> <li>▪ Limited peer-reviewed literature specifically addressing impairment to the auditory system following intense sound exposure.</li> <li>▪ No masking data for intermittent, impulsive air gun source points.</li> <li>▪ Understanding the use of sound by fishes is very poor with few relevant published papers.</li> <li>▪ Lack of specific knowledge about critical fish areas in the Gulf of St. Lawrence.</li> </ul>	

## 6.4 Marine Mammals

Marine mammals are considered a VEC due to their significant role in the offshore ecosystem and because of regulatory protection, and scientific and public concern. This analysis considers cetaceans and pinnipeds that may live and/or migrate through the Project Area.

### 6.4.1 Boundaries

The spatial boundary of interaction is primarily the zone of influence of both the presence of the seismic vessel and generated noise. The spatial distribution of individual species of marine mammals in the Northwest Atlantic is not well known. Therefore, for the purposes of this assessment, it is assumed that species known to occur regularly in the Gulf of St. Lawrence may occur in the Project Area and be potentially affected by Project activities.

Temporal boundaries for this analysis are defined by the Project schedule (mid-May to November). Temporal ecological boundaries for cetaceans and pinnipeds vary according to species. Most cetaceans are migratory and occur in the Gulf of St. Lawrence predominantly during the summer and fall months (Lesage *et al.* 2007).

Knowledge gaps are related to limited information on potential effects of seismic noise, which remain an area of uncertainty. Although there are studies regarding the physical effects of seismic studies on marine mammals, few are focused on local species found within the Project Area. DFO reviewed literature on lab and field studies on the effects of sound on marine organisms (DFO 2004c). They concluded that due to the lack of direct studies on marine mammals, it is unknown if exposure to seismic sound could reduce communication, reduce echolocation, hamper prey detection, hamper predator detection and or hamper parental care. Existing scientific information has been reviewed and applied where appropriate to the proposed Project.

#### **6.4.2 Potential Issues**

There is a considerable amount of literature on potential impacts of seismic surveys on marine mammals; however, almost all the impacts have been inferred or assumed by implication rather than observed (MMS 2004). There have been no documented instances of deaths, physical injuries or auditory effects on marine mammals from seismic surveys (MMS 2004). Behavioural responses have been documented; the importance of this has yet to be determined. Potential interactions between the Project and marine mammals relate primarily to noise disturbance and direct physical effects associated with the vessel and air source operations. These disturbances may lead to the following effects:

- communication masking (*e.g.*, interception of vocalisations);
- behavioural effects associated with seismic noise (*e.g.*, avoidance, changes in migration,
- reproductive and feeding behaviours); and
- direct physical effects associated with seismic noise from air gun during 3D programs, well site surveys and VSPs (*e.g.*, auditory damage, mortality).

Potential interactions between the seismic vessel and individual animals (*e.g.*, collisions) are also considered.

#### **6.4.3 Significance Criteria and Evaluation**

A significant adverse environmental effect occurs when:

- population or portion thereof in such a way as to cause a decline or change in abundance and/or distribution of the population over one or more



generations (may be due to loss of an individual(s) in the case of an endangered species); and/or

- the displacement of any species at risk from critical habitat; and/or
- long term avoidance of the area; and/or
- a disturbance of behavioural patterns adversely affects the ecological functioning of the species population.

A non-significant adverse environmental effect on marine mammals occurs when:

- mortality or serious injury to marine mammals occurs, but does not affect the stock or species at risk; or
- short term displacement from preferred habitat; or
- limited disturbance that does not affect the ecological functioning of the species or stock.

#### **6.4.4 Effects Assessment and Mitigation**

##### **6.4.4.1 Physical Effects**

There are no documented cases of marine mammal mortality from exposure to seismic sounds and DFO (2004c) considers it unlikely that mammal mortality would be caused by seismic sound exposure.

Extended periods of moderate noise levels underwater can cause TTS in some marine mammals. Hearing sensitivity is generally restored quickly after the sound dissipates. A beluga whale exposed to a single peak to peak pressure of 226 dB re 1  $\mu$ Pa experienced TTS to within 2 dB for four minutes after exposure (Finneran *et al.* 2002). A bottlenose dolphin exposed to a single 228 dB re 1  $\mu$ Pa sound did not experience TTS (Finneran *et al.* 2002). Exposure to several seismic pulses at received levels near 200 to 205 dB re 1  $\mu$ Pa (rms), which may be experienced within 100 m of a source vessel, may result in slight TTS in small toothed marine mammals (LGL Limited *et al.* 2005). There are no data on the level or properties of sound that are required to induce a TTS in any baleen whale (LGL Limited *et al.* 2005).

A permanent threshold shift (PTS) may be a symptom of physical damage and may alter the functional sensitivity at some or all frequencies. Although there are no data to quantify sound levels required to cause a PTS, it is believed that a source level would have to far exceed the level required for a TTS, the exposure would have to be prolonged, or the rise level would be extremely short (LGL Limited *et al.* 2005). Richardson *et al.* (1995) hypothesized that permanent hearing impairment of marine

mammals would not likely occur with prolonged exposure to continuous man-made sound of up to about 200 dB re 1  $\mu$ Pa-m. Shifts in mammal hearing thresholds (TTS) are unlikely to be important unless repeated TTS, PTS, or other threats were present concurrently such as potential predators or entanglement in fishing gear (DFO 2004c).

Current NMFS policy in the United States regarding exposure of cetaceans and pinnipeds to sound restricts impulses exceeding 180 and 190 dB re 1  $\mu$ Pa (rms), respectively (NMFS 2000). A source level of 234 dB re 1  $\mu$ Pa (rms) with spherical spreading would create sound pressure levels of 180 and 190 dB re 1  $\mu$ Pa (rms) at distances of 8 to 128 m from the source at 45° emission angle, and 1 to 2 m from source at 0° from horizon emission angle. In the case of the Affected Area, the energy will attenuate through spherical spreading and bend out to sea to the west and until it reaches the seafloor and coastline (to the east), then sound will dissipate through cylindrical spreading. The shallow coastal waters and straight coastline will result in some reflection back out to sea. The Statement of Canadian Practice for Mitigation of Seismic Noise in the Marine Environment (DFO 2006) uses 500 m as the safe working distance from the air source s for marine mammals.

Very little is known about the non-auditory effects of seismic surveys on marine mammals. If such effects exist they would only be expected within a short distance from the vessel. Given that most mammals demonstrate short range avoidance of seismic vessels, non-auditory effects are unlikely to occur for any of the species at risk identified in Table 5.5.

Physical harm is expected to be mitigated by using ramp-up or soft-start procedures which will encourage whales to move from the area prior to physical effects occurring.

The Statement of Canadian Practice for mitigation of seismic noise in the marine environment will also provide guidance to the seismic program. The Statement of Canadian Practice, not yet finalised, aims to formalise and standardise the mitigation measures used in Canada with respect to the conduct of seismic surveys in the marine environment. It is based on a DFO-sponsored peer review by Canadian and international experts. The following points outline the mitigation measures described in the Statement of Canadian Practice:

- Avoid death, harm, or harassment of individuals of marine mammals and sea turtles listed as endangered or threatened on SARA; and population-level effects for all other marine species.
- Avoid, to the extent reasonably practical, causing a dispersion of an aggregation of spawning finfish

- from a known spawning area; a displacement of a group of breeding, feeding or nursing, or migrating, marine mammals, if it is known there are no alternate areas available to those marine mammals for those activities.
- Avoid, to the extent reasonably practical, displacing an individual marine mammal listed as endangered or threatened on SARA from breeding, feeding or nursing, or migrating, if it is known there are no alternate areas for those activities that the individual could be expected to use.
- Establish a safety zone of 500 metres from the centre of the seismic source array or arrays.
- Conduct regular on-going visual monitoring of the safety zone by a qualified Marine Mammal Observer, including continuous visual monitoring during a period of at least 30 minutes prior to start-up of the seismic array.
- Delay start up if a whale, other than a dolphin or a porpoise, is seen within the safety zone during the 30 minute visual survey until the sea turtle or whale has not been observed for at least 30 minutes within the safety zone or has been observed leaving the safety zone.
- Shut down seismic array immediately when a whale is observed to be in the safety zone if that whale is listed as a species of, endangered or threatened on SARA or is listed as a species of special concern for which there could be significant adverse effects.
- Operations may re-commence, using ramp-up/soft-start measures if the array has been shut down for more than 30 minutes. This includes commencing the ramp-up by firing a single source, preferably the smallest source in terms of energy output and volume; and continually activating additional sources in ascending order of size over a 20 to 40 minute period until desired operating level is attained.
- Shut down seismic source array(s) or reduce to a single energy source for line changes. If shut down occurs, ramp-up/soft-start procedures will not be required as alternative measures to maintain the safety zone will be used.
- During periods of low visibility and if the seismic program is in an area known to be an area where a vocalizing whale, other than a dolphin, that is listed as endangered or threatened on SARA, is reasonably expected to be encountered, a ramp-up / soft-start will only commence.

NWest will conduct a marine mammal monitoring program for whale species at risk during survey data acquisition. The reporting of marine mammal observations will use the forms developed under the Joint Nature Conservation Committee (JNCC) Guidelines for Minimising Acoustic Disturbance to Marine Mammals from Seismic Surveys (April 2004). A trained Environmental Observer will watch for marine mammals from the bridge, forward and aft, of the seismic vessel throughout the survey.

NWest will establish a 500 m safety zone for the program and will delay start up of the air guns if a turtle or whale is observed within the safety zone and will shut down the seismic array if a SARA listed whale or turtle is observed within the safety zone. Prior to arriving at the start of a line, the air source array will be slowly brought up to maximum power, a procedure referred to as a “soft start” or “ramping up”. An approved ramp-up procedure will be followed when air source operations begin or after every shutdown. Vessels towing streamers have limited manoeuvrability when the equipment is deployed. NWest is including a 10 km vessel turn-around perimeter around the survey area, during which time the array will be powered down to a single air source (likely the smallest) to warn marine mammals of the presence of the seismic vessel. If the air sources are completely shut down due to maintenance or other purposes, the arrays will be ramped up according to C-NLOPB guidelines, regulations or conditions of authorization.

#### 6.4.4.2 Behavioural Effects

Behavioural changes in whales resulting from seismic surveys will vary by species and even by individuals of the same species. Migrating humpback, grey, and bowhead whales have reacted to sound pulses from marine seismic exploration by deviating from their normal migration route and/or interrupting their feeding and moving away (*e.g.*, Malme *et al.* 1984, 1985, 1988; Richardson *et al.* 1986, 1995; Ljungblad *et al.* 1988; Richardson and Malme 1993; McCauley *et al.* 1998, 2000a,b; Miller *et al.* 1999). Some baleen whales may show strong avoidance at received levels lower than 160 to 170 dB re 1  $\mu$ Pa (rms). The observed avoidance reactions included movement away from feeding locations or statistically significant deviations in the whales’ direction of swimming and/or migration corridor as they approached or passed the sound sources. In the case of the migrating whales, the observed changes in behaviour appeared to be of little biological consequence to the animals. They simply avoided the sound source by slightly displacing their migration route yet remained within the natural boundaries of the migration corridors.

Few studies have been conducted on the reaction of toothed whales to seismic activity but there are numerous observations of dolphins and porpoises bow riding active seismic vessels (*e.g.*, Duncan 1985; Arnold 1996; Stone 2003). However, some studies, especially near the UK, showed localized (~one kilometre) avoidance (Calambokidis and Osmeck 1998, Goold 1996a). There are no specific data on responses of beaked whales to seismic surveys (Würsig *et al.* 1998, Kasuya 1986). One incident of stranding of Cuvier’s beaked whale (*Ziphius cavirostris*) in September 2002 in the Gulf of California after exposure to multi-beam bathymetric sonar, which emits high-frequency sound was

thought to be in the best hearing range of toothed whales like the Cuvier's beaked whale (Malakoff 2002). The evidence linking the Gulf of California strandings to the seismic surveys is inconclusive, and to this date is not based on any physical evidence.

Baleen whales generally avoid an operating air gun, but the avoidance radii appear to be quite variable. Baleen whales, like the listed fin and blue whales, may deviate from a migratory route, suspend feeding or avoid the area. The biological significance of such a change in behaviour is considered slight since there are no uniquely significant habitats identified within the Affected Area and there are alternate feeding and migratory routes. Fin whales are expected to avoid the area of 160 dB and higher. They may tolerate higher decibel levels if they are feeding, rather than migrating, as bowheads apparently do (Miller *et al.* 2005). For instance, migratory bowhead whales may begin to avoid a seismic source 35 km away, but continue feeding until the sound source comes to within 3 km. Fin whales are commonly heard along the edge of the Scotian Shelf from late August, through the fall and again in mid winter, as they migrate to and from wintering grounds to the south (COSEWIC 2005).

Exposure to sounds higher than 130 dB re 1  $\mu$ Pa is possible for mammals within 8 to 10 km. The US NMFS has developed criteria for marine mammal seismic exposure. The level considered harmful to whales is 180 dB re 1  $\mu$ Pa and sound levels of 160 dB re 1  $\mu$ Pa are considered to cause harassment to whales (NMFS 2000). These levels are within 30 m at 0° off horizon, and 256 m (crossline) to 16 km (inline) at 45° emission angle of a sound source at 242 dB re 1  $\mu$ Pa<sub>(rms)</sub>. Whales are not expected to be exposed to these sound levels since they will likely be deterred from the immediate area by the ramp-up procedure. The impact of mammal species at risk would depend on the duration and timing of the seismic survey as well as alternate locations for whichever activity the whales were engaged in.

Whale species at risk are highly dependent on sound for communicating, detecting predators, locating prey, and in toothed whales, echolocation (Lawson *et al.* 2000). Natural ambient noise created by wind, waves, ice and precipitation alone can cause masking or interfere with an animal's ability to detect a sound. Whales themselves also contribute to the level of natural ambient noise. The calls of a blue whale have been recorded for 600 km (Stafford *et al.* 1998). A sperm whale call can be as loud as 232 dB re 1  $\mu$ Pa at 1 m (rms) (Møhl *et al.* 2003)

When anthropogenic noise from ships, drill rigs, seismic and sonar are layered on natural ambient sounds, the level of noise underwater can be quite loud in some areas. In areas where natural background noise is relatively high, such as near a shelf break or high surf, anthropogenic noise itself can be masked and reduce the area in which it is

detectable. The anthropogenic noise is undetectable for marine mammals once it falls below ambient noise level or the hearing threshold of the animal. Given this and the fact that mammal response will vary by species and between individuals, the zone of potential influence of noise on marine mammals is highly variable.

Although masking is a natural phenomenon to which marine mammals must be adapted, introduction of strong sounds into the sea at frequencies important to marine mammals will inevitably increase the severity and the frequency of occurrence of masking. For example, if a baleen whale is exposed to continuous low-frequency sound from an industrial source, this will reduce the size of the area around that whale within which it will be able to hear the calls of another whale. In general, little is known about the importance to marine mammals of detecting sounds from con-specifics, predators, prey, or other natural sources. In the absence of much information about the importance of detecting these natural sounds, it is not possible to predict the impacts if mammals are unable to hear these sounds as often, or from as far away, because of masking by industrial sound (Richardson *et al.* 1995). In general, masking effects are expected to be less severe when sounds are transient than when they are continuous.

Although some degree of masking is inevitable when high levels of man-made broadband sounds are introduced into the sea, marine mammals have evolved systems and behaviour that function to reduce the impacts of masking. Structured signals such as echolocation click sequences of small toothed whales may be readily detected even in the presence of strong background sound because their frequency content and temporal features usually differ strongly from those of the background sound (Au and Moore 1988; 1990). It is primarily the components of background sound that are similar in frequency to the sound signal in question that determine the degree of masking of that signal. Low-frequency industrial sound has little or no masking effect on high-frequency echolocation sounds.

Masking effects of seismic survey sound on marine mammal calls and other natural sounds are expected to be limited. Some whales are known to continue calling in the presence of seismic pulses, which are typically 20 ms in duration and occur every 11 s. Their calls can be heard between seismic pulses (*e.g.*, Richardson *et al.* 1986; McDonald *et al.* 1995; Greene and McLennan 2000). Although there was one report that sperm whales ceased calling when exposed to pulses from a very distant seismic ship (Bowles *et al.* 1994), more recent studies have reported that sperm whales continued calling in the presence of seismic pulses (Madsen *et al.* 2002a; Jochens and Biggs 2003). Toothed whales, and probably other marine mammals as well, have additional capabilities besides directional hearing that can facilitate detection of sounds in the presence of background sound. There is evidence that some toothed whales can shift the dominant

frequencies of their echolocation signals from a frequency range with much ambient sound toward frequencies with less sound (Au *et al.* 1974, 1985; Moore and Pawloski 1990; Thomas and Turl 1990; Romanenko and Kitain 1992; Lesage *et al.* 1999). A few marine mammal species are known to increase the source levels of their calls in the presence of elevated sound levels (Dahlheim 1987; Au 1993; Lesage *et al.* 1999; Terhune 1999).

Masking effects of seismic pulses are expected to be negligible in the case of the smaller odontocete cetaceans, given the intermittent nature of seismic pulses and the fact that sounds important to them are predominantly at much higher frequencies than air gun sounds. Most of the energy in the sound pulses emitted by air source arrays is at low frequencies, with the strongest spectrum levels below 200 Hz, and considerably lower spectrum levels above 1,000 Hz. These frequencies are mainly used by baleen whales, but not by toothed whales or true seals. Furthermore, the discontinuous nature of seismic pulses makes significant masking effects unlikely even for baleen whales. There are reports of whales altering vocalization patterns when exposed to industrial and seismic noise and there are reports of no alteration in vocalization during seismic exposure (DFO 2004c). Whether there is a consequence to any change in vocalization pattern is difficult to determine, but there is potential for reduced ability to communicate information about feeding, breeding, parental care, predator avoidance or maintenance of social grouping. DFO (2004c) has therefore determined it is presently unknown, whether mammal exposure to seismic sound results in reduced communication efficiency. It is also unknown, since there have been no direct studies, of the potential for seismic sound to reduce the efficiency of echolocation in marine mammals (including species at risk), or the potential to hamper passive acoustic detection of prey or predators by marine mammals (DFO 2004c). There is a concern however, that whales exposed to seismic sounds can have a reduced ability to avoid anthropogenic threats such as ship strikes and fishing net entanglements, but the threat has not been demonstrated (DFO 2004c).

#### **6.4.4.3 Vessel Presence**

The potential effects from vessels on marine mammals include strikes, temporary behavioural (aversion or attraction) effects, and effects from vessel noise. The physical presence of the vessel during seismic surveys does not typically result in significant adverse effects regarding collisions. Marine species, in particular marine mammals, are expected to easily avoid the vessel during seismic surveys due to exhibited avoidance behaviour to noise and the slow speed of the ship. The survey vessel will likely travel at an average speed of 4.5 knots when the survey gear is deployed and will increase to approximately 10 knots while in transit. These speeds are within operational activities

of fishing and commercial marine traffic. While the potential for collision exists, collision events are predicted to be unlikely. Collision with an endangered species would be considered significant; however, since there are no records of collision between the listed species at risk and seismic vessels, the probability of occurrence is considered low. Bow wave riding delphinids is considered an attraction behaviour response and unavoidable, and is not considered an adverse effect.

Seismic vessels activity is a minor component of total marine transportation. Two seismic surveys are planned for 2008, with one survey for three years in total, compared with the hundreds of commercial tanker, cargo ships, research vessels, cruise ships, fishing vessels and offshore supply vessel trips in the vicinity of the survey Activity Area. The additional vessel activity from the survey is negligible compared to the other vessels and cumulative impacts on species at risk are not significant.

#### **6.4.4.4 Accidental Events**

Spilled oil may affect marine mammals through dermal contact, inhalation, ingestion and/or fouling of baleen plates. Potential impacts will be short-lived due to the high volatility and relatively small volume of the spilled oil (diesel or kerosene) and confinement to surface water. No significant adverse effects are anticipated for marine mammals as a result of small volume accidental spills.

#### **6.4.5 Cumulative Effects**

In general, because the sounds generated by seismic surveys are transient and do not "accumulate" in the environment, the most likely cumulative effects will be associated with other concurrent activities (*e.g.*, cargo ships, tankers, oil and gas exploration and production activities, other seismic surveys, fishing vessels). Studies in the Gulf of Mexico showed that seismic surveys produce a relatively minor contribution to the overall underwater noise environment (MMS 2004). The cumulative effect is short term, intermittent and localised, and therefore, not significant with respect to effects on species at risk.

Two seismic exploration projects will be active in the vicinity of the Project Area. PDI Productions Inc. was to commence work in the fall of 2007 in the Port au Port area (EL 1070) but if the Project undergoes unavoidable delays, the seismic work could be undertaken anytime in the next three years. Tekoil and Gas Corp. is conducting seismic work over part of, and adjacent to, the Port au Port Peninsula (EL 1071) during a six-week period from October 2008 to April 2009. In the event of other seismic surveys being



conducted on the Western Shelf within the proposed timeframe, a significant distance between surveys will be necessary to prevent both operational conflict and acoustical interference. This will reduce or eliminate the likelihood that the sound levels from two surveys will be additive in a particular area, and reduce the potential for cumulative effects on species at risk. The location of these two surveys are in the same location and are 68.5 km south the most southern boundary of the Project Area and 143 km from Seismic Survey Area Option 2.1. There will be no spatial or temporal overlap between these projects and the NWest Project.

In general, the seismic survey vessel activity and noise will constitute a minor percentage contribution to the overall noise generated by other such sources and space-user conflict, and will be of short duration in local areas. Based on current knowledge, and especially with the proposed mitigation procedures in place, the proposed Project is not expected to result in, or contribute to, any significant cumulative impacts on species at risk.

#### **6.4.6 Monitoring and Follow-up**

A dedicated environmental observer will be on board the seismic vessel. The Fisheries Liaison Observer will record sightings of marine mammals on a daily basis, weather permitting. If a concentration of marine mammals is observed in a particular area, the survey can shift to another part of the survey area until the concentration has moved away. This, along with a 30-minute ramp-up procedure will ensure that whale species at risk in the Affected Area are not significantly affected in an adverse manner.

NWest will conduct a periodic review of the EA Report to determine the validity of species at risk assessment and acknowledges that additional mitigation may be necessary should new species be added to Schedule 1 over the life of the Project.

#### **6.4.7 Summary**

Table 6.4 summarises the environmental effects on marine mammals from the NWest geophysical surveys.

**Table 6.4 Summary of Environmental Assessment for Marine Mammals**

<b>Interactions and Issues</b>	
<ul style="list-style-type: none"> <li>• Disturbance of marine mammals caused by the presence of vessels, particularly with regard to collisions with species at risk.</li> <li>• Noise from seismic leading to masking of cetacean vocalisation; behavioural changes; temporary threshold shift or hearing impairment; or</li> <li>• physical injury.</li> </ul>	
<b>Impact Analysis</b>	
<p>There is lack of published information regarding avoidance thresholds in odontocete whales, however, baleen whales exhibit clear avoidance behaviours at threshold levels of approximately 160 to 170 dB re 1µPa (rms) (Davis <i>et al</i>, 1998). NMFS policy regarding exposure of marine mammals to high-level sounds is that whales should not be exposed to impulse sounds exceeding 180 dB re 1µPa (rms), although behavioural changes are apparent at 160 dB re 1µPa (rms) (NMFS 2000). Therefore, using 170 dB re 1µPa (rms) (≈160 dB re 1µPa (SEL)) as a received sound level boundary, the minimum and maximum distance from a 242 dB re 1µPa<sub>(rms)</sub> at 1m broadband source to an attenuation of 170 dB re 1µPa<sub>(rms)</sub> is 32 km at 0° from horizon and 2 km at 45° in 150 m water depth.</p> <p>Effects from seismic activities may result in physical injury and auditory impairment in cetaceans that are in close proximity to the firing air source array, a distance that should be avoided by marine mammals through ramping-up or when they hear the approaching seismic vessel. Auditory damage and mortality as a result of seismic activities and/or vessel traffic is not considered to be a major concern with respect to the proposed Project. The proposed Project may result in behavioural effects on marine mammals; however, most studies indicate that such behavioural disturbances are likely to be transitory with normal behaviour resuming within an hour or two after vessel passage. Mortality, serious injury or displacement from behavioural patterns that disrupt the ecological functioning of a species are not expected as there is no evidence nor expectation that seismic activities will result in these effects (MMS 2004).</p>	
<b>Mitigation</b>	
<ul style="list-style-type: none"> <li>• Collision avoidance practices, including constant speed and course maintained by seismic and support vessels.</li> <li>• Trained observer on the seismic vessel to ensure that air source s are shut down if endangered or threatened cetaceans are present within 500 m of the seismic vessel.</li> <li>• Ramp-up procedure will be implemented, prior to start. Ramp-up will be delayed if a marine mammal is present within 500 m of the seismic vessel.</li> </ul>	
<b>Significance evaluation</b>	
Likelihood of occurrence	Medium
Geographic extent	Immediate to Regional for disturbance effects
Frequency of occurrence	Intermittent during 3-D data acquisition (20-30 days or up to 75 days) Intermittent for one week for well site survey Continuous for hours for VSP
Duration of impact	Immediate
Magnitude of impact	Low
Permanence/reversibility	Reversible, immediate recovery after Project activities cease
Significance of Effect	Not adversely significant
<b>Confidence</b>	
<ul style="list-style-type: none"> <li>• High level of confidence related to significance rating given international and local industry experience.</li> </ul>	

## 6.5 Sea Turtles

Sea turtles are considered a VEC due to their special conservation status and uncertainty regarding their distribution in the Project Area. Any loss of breeding adults, above that caused by natural predation and disease, can lead to significant declines in population.

### 6.5.1 Boundaries

The spatial boundaries for the assessment of sea turtles include the entire Project Area as shown on Figure 4.1, although it is recognised that sea turtles have widespread distribution patterns from the Caribbean to the Northwest Atlantic, as far north as Labrador.

Temporal boundaries are defined by the Project schedule (August to October 2008 and May to December 2009 to 2015). Marine turtles are likely to occur in the Project Area during the summer and fall months. Knowledge gaps include a lack of specific information for marine turtles within the Project Area. For the purpose of this assessment, it is assumed that any species of sea turtle that could potentially be present offshore Newfoundland could be present within the Project Area.

### 6.5.2 Potential Issues and Interactions

Potential interactions between the Project seismic surveys and sea turtles relate primarily to auditory damage and behavioural effects (*e.g.*, avoidance behaviour, increased swimming speeds).

### 6.5.3 Significance Criteria and Evaluation

A significant adverse environmental effect on sea turtles is one that may result in:

- mortality or serious injury of one or more individuals of a species at risk and/or
- long-term displacement from preferred or critical habitat; and/or
- change in the preferred or critical habitat.

A non-significant adverse environmental effect on sea turtles is one that may result in:

- minor injury of one or more individual of any sea turtles species; and/or
- short term displacement from preferred or critical habitat.

## 6.5.4 Effects Assessment and Mitigation

### 6.5.4.1 Auditory Damage

Sea turtles remain submerged for the majority of time and thus may be exposed to the highest sound levels as the vessel and towed equipment pass overhead. Studies on sea turtle hearing are limited and the role in their ecological functioning is not well known. Maximum hearing sensitivity in sea turtles has been observed in the 100 to 700 Hz range (Ridgway *et al.* 1969, McCauley 1994, Davis *et al.* 1998). TTS was observed by Moein *et al.* (1994) when loggerhead turtles were exposed to a few hundred air source pulses approximately 65 m away. Moein *et al.* (1994) do not describe the received sound levels or size of the air source used, making it difficult to estimate the sound level that caused TTS in loggerhead turtles. The hearing capabilities of the loggerhead turtles returned to normal two weeks later. Temporary or permanent hearing impairment may occur at close range, but life-threatening injury or mortality is unlikely.

### 6.5.4.2 Behavioural Effects

The Australian Petroleum Production and Exploration Association sponsored an experimental program between 1996 and 1999 to study the environmental implications of marine seismic surveys. One of the components of this program, run by the Centre for Marine Science and Technology of Curtin University in Western Australia, involved trials with an air gun approaching caged sea turtles, fishes and squid (McCauley *et al.* 2000). Observers noted erratic behaviour (“alarm response”) of caged loggerhead and green turtles at received sound levels of 175 dB re  $\mu\text{Pa}_{(\text{rms})}$  (or 185 dB re  $1 \mu\text{Pa}_{(0-p)}$ ) while received sound levels of 166 dB re  $\mu\text{Pa}_{(\text{rms})}$  (or 176 dB re  $1 \mu\text{Pa}_{(0-p)}$ ) triggered avoidance behaviour. Marine turtles displayed no long-term neurophysical damage. Although a reduction in hearing capability was evident, the effect was temporary and returned to normal within a short period of time (McCauley *et al.* 2000). The avoidance reaction could be generated by this 3-D program array of 242 dB re  $1 \mu\text{Pa}_{(\text{rms})}$  at a distance between 128 m (crossline) to 4 km (inline) at 45° emission angle and 32 m at 0° off horizon. Erratic behaviour could result between 8 m and 1 km based on 0° and 45° angles of emission, respectively. Marine turtles are expected to display behavioural changes at around two kilometres and avoidance around one kilometre from the seismic array (McCauley *et al.*, 2000). These results were consistent with other similar studies (*e.g.*, O’Hara and Wilcox 1990; Moein *et al.* 1994) that demonstrated avoidance of operating air guns. It is therefore reasonable to assume that marine turtles in the Project Area would attempt to avoid the operating seismic vessel, thereby limiting their

exposure to increased noise levels. Eckert *et al.* (1989) stated that the leatherback turtle can achieve a sustainable swimming speed of 3.6 km/hr. If avoidance behaviour is triggered at 176 dB re 1  $\mu\text{Pa}_{(0-p)}$ , the ramp-up procedure will provide sufficient time for turtles to move away from the source. The Science Review Working Group, in their evaluation of two proposed seismic surveys near Cape Breton agreed that based on the limited knowledge of marine turtle response to sound; effects from seismic activities are likely to be sublethal, affecting fitness of exposed individuals only. They recommended that the ramp up be a minimum of 30 minutes to allow for the marine turtle's swimming speed (CNSOPB 2002). Any avoidance behaviour caused by the Project is expected to be temporary and is not predicted to affect migration patterns and reproductive behaviour, particularly as the marine turtles found in the Project Area are considered migrants, with major breeding grounds located well to the southwest of the Project Area. Survey activities are not expected to affect the distribution or abundance of marine turtle prey items (*e.g.* jellyfish). The NWest geophysical surveys are, therefore, not predicted to result in a significant adverse effect on the foraging leatherback turtle population in the Gulf of St. Lawrence.

#### **6.5.4.3 Vessel Presence**

There is some risk to marine turtles from collision with seismic vessels, as they would be with fishing and commercial marine traffic. As they are submerged for the most part and may avoid seismic arrays, the risk of mortality or serious injury is anticipated to be low (MMS 2004). OGOB observers have not noted the presence of marine turtles during seismic surveys; however, visual monitoring provides limited mitigation due to the low profile of marine turtles in the water.

#### **6.5.4.4 Accidental Events**

Oil may affect marine turtles through dermal contact, inhalation or ingestion. This risk of such events occurring is low. Potential impacts will be short-lived and confined to the surface water. No significant adverse effects are likely to occur as a result of an accidental event associated with this Project.

#### **6.5.5 Follow-up and Monitoring**

DFO reviewed literature on lab and field studies of the effects of sound on marine organisms (DFO 2004c). Because sea turtles are visually and acoustically difficult to detect, the mitigation of observing to avoid is considered less effective than for marine

mammals. However, the air source array will be shut down if a sea turtle is observed within 500 m of the seismic vessel (500 m from the vessel is more conservative than 500 m from the arrays, as the vessel is moving forward at approximately 4 to 5 kn). A trained observer will keep records of marine turtles within visual range, weather permitting. Given the lack of systematic surveys for marine turtles in the Project Area, this opportunity for observation of marine turtles will add to the understanding of their distribution offshore Newfoundland and may provide additional insight into their behavioural response to seismic activities.

#### **6.5.6 Cumulative Effects**

In general, because the sounds generated by seismic surveys are transient and do not "accumulate" in the environment, the most likely cumulative effects will be associated with other concurrent activities (*e.g.*, cargo ships, tankers, oil and gas exploration and production activities, other seismic surveys, fishing vessels). Studies in the Gulf of Mexico showed that seismic surveys produce a relatively minor contribution to the overall underwater noise environment (MMS 2004). The cumulative effect is short term, intermittent and localised, and therefore, not significant with respect to affects on species at risk.

Two seismic exploration projects will be active in the vicinity of the Project Area. PDI Productions Inc. was to commence work in the fall of 2007 in the Port au Port area (EL 1070) but if the Project undergoes unavoidable delays, the seismic work could be undertaken anytime in the next three years. Tekoil and Gas Corp. is conducting seismic work over part of, and adjacent to, the Port au Port Peninsula (EL 1071) during a six-week period from October 2008 to April 2009. In the event of other seismic surveys being conducted on the Western Shelf within the proposed timeframe, a significant distance between surveys will be necessary to prevent both operational conflict and acoustical interference. This will reduce or eliminate the likelihood that the sound levels from two surveys will be additive in a particular area, and reduce the potential for cumulative effects on species at risk. The location of these two surveys are in the same location and are 68.5 km south the most southern boundary of the Project Area and 143 km from Seismic Survey Area Option 2.1. There will be no spatial or temporal overlap between these projects and the NWest Project.

In general, the seismic survey vessel activity and noise will constitute a minor percentage contribution to the overall noise generated by other such sources and space-user conflict, and will be of short duration in local areas. Based on current knowledge, and especially with the proposed mitigation procedures in place, the proposed Project is

not expected to result in or contribute to any significant cumulative impacts on species at risk.

### 6.5.7 Summary

Table 6.5 summarises potential interactions, environmental effects, mitigation, residual and cumulative effects on marine turtles from the NWest geophysical surveys.

**Table 6.5 Summary of Environmental Assessment for Marine Turtles**

<b>Interactions and Issues</b>	
<ul style="list-style-type: none"> <li>• noise from seismic surveys</li> <li>• entanglement and vessel cables</li> </ul>	
<b>Impact Analysis</b>	
Potential interactions between marine turtles and the Project are expected to be insignificant, if at all, based on their transitory presence in the Project Area and tendency to avoid seismic operations. Ramp up procedures will also serve to further minimise direct effects on marine turtles. With the implementation of the recommended mitigation measures, the residual environmental effects of planned Project components on marine turtles are evaluated as not significant	
<b>Mitigation</b>	
<ul style="list-style-type: none"> <li>• Ramp-up procedure will be implemented.</li> <li>• Air source s will be shut down if a sea turtle is observed within 500 m.</li> <li>• Ramping up will be delayed if a sea turtle is observed within 500 m.</li> </ul>	
<b>Significance evaluation</b>	
Likelihood of occurrence	Medium
Geographic extent	Local to Regional
Frequency of occurrence	Intermittent during 3-D data acquisition (20-30 days or up to 75 days) Intermittent for one week for well site survey Continuous for hours for VSP
Duration of impact	Immediate
Magnitude of impact	Low
Permanence/reversibility	Reversible, immediate recovery after Project activities cease
Significance of Effects	Not adversely significant
<b>Confidence</b>	
High level of confidence related to significance rating given extensive local and international industry experience.	

## 6.6 Species at Risk

### 6.6.1 Boundaries

The spatial boundaries of interaction between species at risk and the Project are primarily related to the zone of influence as predicted by modelling of noise attenuation from the seismic array.

Ecological spatial boundaries vary between the various species at risk although it is recognised that most species at risk range beyond the Project Area:

- The only known spawning area for fish species at risk within the Regional Area is for cod as identified on Figure 5.21. This area is outside the Project Area. Skate cases, and wolffish eggs and larvae are demersal. Sharks are not known to bear young in the Affected Area.
- The ecological spatial boundary for marine bird species at risk includes the breeding, nesting and foraging habitat of Harlequin Ducks. This species uses the nearshore coastal waters and watercourse in Gros Morne National Park has limited potential for interaction with this Project. There are no known nesting grounds for the Ivory Gull in the Affected Area, and any presence in the area is expected to be incidental.
- Four species of marine mammals at risk to occur in the Gulf of St. Lawrence (Lesage *et al.* 2007), occur in the Affected Area and can be potentially affected by Project activities.
- Spatial distribution for marine turtles is vast and encompasses most of the Scotian Slope and extends into the Gulf of St. Lawrence and Labrador but to no known extent. Leatherback turtles generally migrate between the warm and cold waters seasonally, migrating north to forage and south to breed in the Gulf of Mexico or in the Caribbean Sea. For the purpose of this assessment, it is assumed that marine turtles occur in the Project Affected Area.

With respect to temporal boundaries, the potential interactions of concern are those related to the seismic activities that could occur at any time of year during a eight year (2008 to 2015) time period.

- Cod are the only fish species at risk to spawn near the Project Area. Cod spawn in April to May in this area, and the surveys are likely not to interact. Spawning habitat for the other species at risk is not known to occur in the Project Area.
- The temporal boundaries of Harlequin Ducks occur largely during the moulting months. The timing of male and female moulting are not the same but do overlap. Peak activity of male and female moulting occurs from early July to late September and from late August to early October, respectively (Robertson and Goudie 1999). The presence of Ivory Gull in the Affected Area would be incidental and therefore there are no relevant temporal boundaries for this species.



- The temporal ecological boundaries for cetaceans vary according to species. Most cetaceans are migratory and occur in the Gulf of St. Lawrence predominantly during the summer and fall months (Reeves and Brown 1994), and thus may be in the Project Area during surveys.
- Marine turtles are likely to occur in the Project Area during the summer and fall months.

With regard to administrative boundaries, the SARA is administered by Environment Canada, Parks Canada, and DFO. The boundaries of the critical habitat for each species are defined in species recovery strategies, action plans and management plans.

The technical boundaries of the assessment include limited knowledge on potential effects of seismic sounds on individual species at risk found in the Affected Area and the lack of information on the use of the Regional Area by species at risk. Because there is little species-specific information directly related to species at risk in the Affected Area, existing scientific information has been reviewed and applied generically where appropriate to the proposed Project seismic surveys.

#### **6.6.2 Potential Issues and Interactions**

Potential interactions between routine Project activities and species at risk relate primarily to behavioural and physiological effects associated with air source operations. These disturbances may lead to the following effects:

- direct physical effects associated with seismic noise;
- behavioural effects associated with seismic noise; and
- auditory and communication masking by seismic noise in fish and mammals.

There are also likely interactions associated with operation of the seismic vessel and vessel traffic, particularly for bird species (*e.g.*, attraction noise and lights), sea turtles, and marine mammals (*e.g.*, collisions with vessels).

#### **6.6.3 Significance Criteria and Evaluation**

A significant, adverse environmental effect is one that, after application of all feasible mitigation and consideration of all reasonable Project alternatives,

- will prevent the achievement of self-sustaining population objectives or recovery goals;

- will result in exceedance of applicable allowable harm assessments; and/or
- for which an incidental harm permit would not likely be issued. Due to the sensitive nature of species at risk, residual adverse effects on one individual may be considered significant.

A non-significant, adverse environmental effect is one that, after application of all feasible mitigation and consideration of all reasonable Project alternatives,

- results in threats to individuals, residences or critical habitat of listed species that does not jeopardize the survival or recovery of the species;
- does not result in exceedance of applicable allowable harm assessments; and/or
- for which an incidental harm permit would likely be issued.

#### **6.6.4 Effects Assessment and Mitigation**

Potential effects on species at risk are discussed in Section 6.1.4 for marine and migratory birds, Section 6.2.4 for fish, Section 6.3.4 for marine mammals and Section 6.4.4 for marine turtles. Recovery plans for the species at risk that may or do occur in the Affected Area are discussed below with respect to mitigation measures applied to the Project. Recovery plans for blue whales and cod are pending and will be considered over the course of the eight year period, if they become available.

##### **6.6.4.1 Marine and Migratory Bird Species at Risk**

###### **Harlequin Ducks**

Potential impacts of vessel traffic on Harlequin Ducks have been identified in the 'Management Plan for the Harlequin Duck (*Histrionicus histrionicus*) Eastern Population, in Atlantic Canada and Quebec' (Environment Canada 2007). Vessel traffic will be well offshore and out of range of any direct impact with Harlequin Ducks; however, in the unlikely event of disturbance, mitigation measures are addressed below.

Harlequin Ducks are potentially impacted by vessel activity mainly during the moulting and wintering period. One of the most significant threats to North American moulting and wintering population of Harlequin Ducks is potential for oil contamination. Minimal amounts of oil will be aboard the seismic vessel. Potential oil spillage may occur from ballast and bilge water discharge but will be regulated to ensure that oil concentrations in the discharge do not exceed 15 mg/L as required by the MARPOL

73/78 (International Convention for the Prevention of Pollution from Ships 1972, and the Protocol of 1978 related thereto), International Maritime Organization and OWTG. Any accidental spills will be reported to the C-NLOPB immediately.

#### **6.6.4.2 Fish Species at Risk**

##### **Atlantic Cod, Northern Wolffish, Spotted Wolffish, Atlantic Wolffish, Porbeagle Shark and Shortfin Mako Shark**

Potential impacts of vessel traffic on Atlantic cod and several species of wolffishes have been identified in 'A Strategy for the Recovery and Management of Cod Stocks in Newfoundland and Labrador' (2005) and 'Recovery Strategy for the Northern Wolffish (*Anarhichas denticulatus*) and Spotted Wolffish (*Anarhichas minor*), and Management Plan for Atlantic Wolffish (*Anarhichas lupus*) in Canada' (Kulka *et al.* 2007), respectively. Areas of concern related to vessel traffic and mitigation measures are addressed below.

Seismic activities may potentially impact Atlantic cod and wolffish recovery in Atlantic Canada; however, no evidence is documented to support the claim that seismic activity results in serious or irreversible harm exists. Nonetheless, mitigation measures will include a gradual increase in intensity of air gun discharge to allow fish to avoid the source of the sound, public notices to alert fishers of the seismic activity, and avoidance of seismic activities during known sensitive areas and timeframes for Atlantic cod spawning. The seismic survey area is a minimum of 35 km (including 10 km buffer area) northeast of the cod spawning area which is near ambient levels for the proposed 3-D seismic surveys. The Project is unlikely to result in population level effects on that fish species at risk based on scientific research to date.

Critical habitat for the three wolffish species, winter skate and the listed two species of sharks has not been documented geographically in the Gulf of St. Lawrence. Only spawning grounds for Atlantic cod occur near the Affected Area. Behavioural effects on fish and spawning fish have been discussed in detail in Section 6.2.2.

Fish use sound for communication, navigation and sensing of prey and predators. In particular, sound transmission is thought to play an important role in cod mating. (Engen and Folstad 1999; Hawkins and Amorin 2000). One study on the acoustic sound production of Atlantic cod provides some insight into possible mating behaviours. Drumming muscles are present in both males and females, yet males tend to have more pronounced muscles. The mass of the drumming muscles increases in males prior to spawning and larger males have larger muscles. This suggests that the amplitude of sound production might be a determinant in the success of spawning and selection by

females. Observations of Atlantic cod behaviour support the hypothesis that females are responsible for mate selection. The biology of the drumming muscles in males, as well as the circling behaviour of numerous males around prospective females supports the female selection hypothesis.

A comparison of moderately sensitive species such as cod, haddock, pollock and redfish determined a measurable behavioural response in the range of 160 to 188 dB re 1 $\mu$ Pa (Turnpenny and Nedwell 1994). Source levels during seismic surveys are usually in excess of the noise levels that elicit a response in fish, so the area in which fish react to the noise may extend up to 16 km in the open ocean. By comparison underwater ambient noise in bad weather is in the range of 90 to 100 dB re 1  $\mu$ Pa. Sea ice noise can be significant and highly variable. The spring noise spectra peaked at about 90 dB re 1  $\mu$ Pa. Spawning cod would be exposed to the spring ice melt noises. Large tankers may have a source noise level of 170 dB re 1  $\mu$ Pa at 1 m.

Effects of auditory masking on fish are discussed in detail in Section 6.2.2. The proposed seismic survey are not expected to cause long-term or permanent displacement of any listed species from critical habitat or other preferred habitat nor result in destruction or adverse modification of critical or essential fish habitat. Therefore, potential impacts to fish species at risk will be negligible most of the time with occasional impacts being potentially adverse but not significant.

#### **6.6.4.3 Marine Mammal and Sea Turtle Species at Risk**

##### **North Atlantic Right Whale and Leatherback Turtles Recovery Plans**

Several potential impacts of vessel traffic on North Atlantic right whales and leatherback turtles have been identified in the 'Canadian North Atlantic Right Whale Recovery Plan' (Fisheries and Oceans Canada 2000) and the 'Recovery Strategy for the Leatherback Turtle (*Dermochelys coriacea*) in Atlantic Canada' (Atlantic Leatherback Recovery Team 2006), respectively. Areas of concern related to vessel traffic and mitigation measures are addressed below.

Vessel collisions, noise disturbance and habitat degradation have been identified as three of the main threats to North Atlantic right whale and leatherback turtle recovery. To mitigate these potential risks, vessels will gradually increase the intensity of the air source discharge to allow time for whales and turtles to avoid the sound. In addition, a qualified offshore Environmental Observer from the vessel will be assigned to look for evidence of North Atlantic right whales (*i.e.*, whale footprints, surfacing) and leatherback turtles (*i.e.*, basking) in the vicinity of the vessel. In the event of either

species presence, the vessel will cease seismic activity and take appropriate measures to avoid collision. Vessel operations will only commence when North Atlantic right whales and leatherback turtles are outside a 500 m safety radius of the seismic activity.

Entanglement with fishing gear has potential to impact North Atlantic right whale and leatherback turtle recovery. No fishing gear will be aboard the vessel, therefore, no mitigation measures are required. There are no records of marine turtles or marine mammals becoming entangled in seismic arrays or hydrophone cables.

Petroleum spills are a major threat to North Atlantic right whale and leatherback turtle recovery. Minimal amounts of oil will be aboard the seismic vessel. Potential oil spillage may occur from ballast and bilge water discharge but will be regulated to ensure that oil concentrations in the discharge do not exceed 15 mg/L as required by the MARPOL 73/78 (International Convention for the Prevention of Pollution from Ships 1972, and the Protocol of 1978 related thereto), International Maritime Organization and OWTG. NWest will contract a seismic vessel equipped with solid-streamer technology, as this type of streamer is not reliant on floatation fluid to achieve a neutral ballast state, thus reducing the risk of accidental spill. Any accidental spills will be reported to the C-NLOPB immediately.

Marine noise is a highly emotive issue as it affects cetaceans (large marine mammals, such as whales, dolphins and porpoises). Initial studies have established that noise generated from offshore operations present a low risk to marine life, but due to a lack of data for sensitive species, this statement cannot be adequately defined in all cases.

There are no documented cases of marine mammal mortality from exposure to seismic sounds and DFO (2004c) considers it unlikely that mammal mortality would be caused by seismic sound exposure.

A dedicated Environmental Observer will be on board the seismic vessel. If a concentration of marine mammals is observed in a particular area, the survey can shift to another part of the survey area until the concentration has moved away. This, along with a 30-minute ramp-up procedure will ensure that whale species at risk in the Affected Area are not significantly affected.

The potential effects from vessels on marine mammals include strikes, temporary behavioural (aversion or attraction) effects, and effects from vessel noise. The physical presence of the vessel during seismic surveys does not typically result in significant adverse effects. Marine species, in particular marine mammals, are expected to easily avoid the vessel during seismic surveys due to exhibited avoidance behaviour to noise

and the slow speed of the ship. The survey vessel will likely travel at an average speed of 4.5 kn when the survey gear is deployed and will increase to approximately 10 kn while in transit. While the potential for collision exists, collision events are predicted to be unlikely. Collision with an endangered species would be considered significant; however, since there are no records of collision between the listed species at risk and seismic vessels, the probability of occurrence is considered low.

There is some risk to marine turtles from collision with seismic vessels. As they are submerged for the most part and may avoid seismic arrays, the risk of mortality or serious injury is anticipated to be low (MMS 2004). Environmental observers have not noted the presence of marine turtles during seismic surveys; however, visual monitoring provides limited mitigation due to the low profile of marine turtles in the water, limited surface time, and solitary nature at sea.

Physical harm is expected to be mitigated by using ramp-up or soft-start procedures which will encourage whales to move from the area prior to physical effects occurring. The *Statement of Canadian Practice for Mitigation of Seismic Noise in the Marine Environment* for ramp-up and shut down of the air sleeves will be closely followed to avoid death, harm or harassment of individuals of marine mammals and sea turtles listed under SARA. Specifically, the ramp-up of the air sleeve to seismic survey capacity will occur over a 20- to 40-minute period to initiate a behavioural avoidance response in marine mammals whereby they will leave the Project Affected Area prior to experiencing hearing damage.

NWest will make the necessary arrangements to ensure that a qualified environmental observer will be on board the survey vessel at all times during the survey period. The observer will conduct continuous monitoring for marine mammals for 30 minutes prior to start-up of the seismic array. Should any sea turtle be observed in a 500-m zone from the centre of the seismic source array, start-up will be delayed until the animal has not been observed for 30 minutes. The survey will also shut down should the observer detect a turtle within 500 m from the centre of the seismic source array.

#### **6.6.5 Follow up and Monitoring**

Monitoring of species at risk is the same as for unlisted species discussed in the appropriate VEC sections above.

### 6.6.6 Cumulative Effects

Seismic vessel activity is a minor component of total marine transportation. Two other geophysical surveys are anticipated on the west coast of Newfoundland during 2008, compared with the multitude of commercial tanker, cargo ships, research vessels, cruise ships, fishing vessels and offshore supply vessel trips in the vicinity of the western coast of Newfoundland. The additional vessel activity from the survey is negligible compared to the other vessels and cumulative impacts on species at risk are not significant.

In general, because the sounds generated by seismic surveys are transient and do not "accumulate" in the environment, the most likely cumulative effects will be associated with other concurrent activities (*e.g.*, cargo ships, tankers, oil and gas exploration and production activities, other seismic surveys, fishing vessels). Studies in the Gulf of Mexico showed that seismic surveys produce a relatively minor contribution to the overall underwater noise environment (MMS 2004). The cumulative effect is short term, intermittent and localised, and therefore, not significant with respect to affects on species at risk.

Two seismic exploration projects will be active in the vicinity of the Project Area. PDI Productions Inc. was to commence work in the fall of 2007 in the Port au Port area (EL 1070) but if the Project undergoes unavoidable delays, the seismic work could be undertaken anytime in the next three years. Tekoil and Gas Corp. is conducting seismic work over part of, and adjacent to, the Port au Port Peninsula (EL 1071) during a six-week period from October 2008 to April 2009. If these other seismic surveys being conducted on the west coast within the proposed timeframe, a significant distance between surveys will be necessary to prevent both operational conflict and acoustical interference. This will reduce or eliminate the likelihood that the sound levels from two surveys will be additive in a particular area, and reduce the potential for cumulative effects on species at risk. The location of these two surveys are in the same location and are 68.5 km south the most southern boundary of the Project Area and 143 km from Seismic Survey Area Option 2.1. There will be no spatial or temporal overlap between these projects and the NWest Project.

In general, the seismic survey vessel activity and noise will constitute a minor percentage contribution to the overall noise generated by other such sources and space-user conflict, and will be of short duration in local areas. Based on current knowledge, and especially with the proposed mitigation procedures in place, the proposed Project is not expected to result in or contribute to any significant cumulative impacts on species at risk.

### 6.6.7 Summary

A summary of potential interactions, environmental effects, mitigation, and cumulative and residual environmental effects is provided in Table 6.6.

**Table 6.6 Summary of Environmental Assessment for Species at Risk**

<b>Interactions</b>	
<ul style="list-style-type: none"> <li>▪ Direct physical effects associated with seismic noise (<i>e.g.</i>, auditory damage, egg and larval mortality).</li> <li>▪ Behavioural effects associated with seismic noise (<i>e.g.</i>, avoidance, changes in migration, reproduction and feeding).</li> <li>▪ Communication masking by seismic noise in fish and mammals (<i>e.g.</i>, during spawning/mating, feeding, etc.).</li> <li>▪ Disturbance from vessel noise and lights.</li> </ul>	
<b>Impact Analysis</b>	
Potential adverse environmental effects on species at risk will be unlikely because of planned monitoring and mitigation measures. In addition, species at risk are expected to show some avoidance of the areas of highest received levels of seismic sounds. Therefore, there is not likely to be a significant adverse environment effect on species at risk.	
<b>Mitigation</b>	
<ul style="list-style-type: none"> <li>▪ Adherence to the <i>Statement of Canadian Practice on the Mitigation of Seismic Noise in the Marine Environment</i> to the extent reasonably practical.</li> <li>▪ A 500-m safety zone monitoring program for whale species at risk during survey data acquisition will be implemented.</li> <li>▪ A dedicated Environmental Observer will be onboard the seismic vessel. If a concentration of marine mammals is observed in a particular area, the survey can shift to another part of the survey area until the concentration has moved away.</li> <li>▪ To minimize sudden changes in noise levels, a ramp up procedure will be implemented.</li> <li>▪ Collision avoidance practices, including constant speed and course maintained by seismic vessels.</li> <li>▪ Compliance with OWTG (NEB <i>et al.</i> 2002) for all discharges.</li> <li>▪ Avoidance of bird colonies in Gros Morne National Park</li> <li>▪ Avoidance of the cod spawning area</li> </ul>	
<b>Significance</b>	
Likelihood of occurrence	Medium
Geographic extent	Local to Regional for disturbance effects.
Frequency of occurrence	Intermittent for the 3-D program ( 20-30 days or up to 75 days) Intermittent for the well site survey (one week) Continuous for the VSP ( hours)
Duration of impact	Immediate
Magnitude of impact	Low
Permanence/reversibility	Reversible, immediate recovery after Project activities cease.
Significance of Effects	Not adversely significant
<b>Confidence</b>	
High level of confidence based on previous seismic surveys.	



## **6.7        Sensitive Areas**

Special Areas include “sensitive areas” such as important or critical habitat that may be affected by the Project, or areas that have special conservation status by law. There are four sensitive areas within and in close proximity to the Project Area: Gros Morne National Park , two lobster nursery areas and the cod spawning area. Details of these sites are provided in Section 5.2.7

### **6.7.1        Boundaries**

The spatial boundaries of interaction between the Sensitive Areas and the Project seismic surveys are primarily related to the zone of influence as predicted by noise attenuation from the seismic array. Seismic noise 160 to 170 dB re  $\mu\text{Pa}$  (rms), below harmful and harassment levels for marine mammals and turtles may occur within 100 m at 0° from horizon and 200 m at 45° angle of emission (crossline) from horizon.

There will be no incursion of the vessel into the cod spawning area and navigation of the seismic vessel for turning purposes will be a minimum of 35 km distance. The Project Area is located 30 km offshore of Gros Morne National Park and will not interact with Harlequin Ducks.

With respect to temporal boundaries, the potential interactions of concern are those related to the seismic activities that could occur in August to October in 2008 for the first seismic survey and between May and December within the next seven-year (2009 to 2015) time period for subsequent surveys.

With regard to administrative boundaries, Parks Canada is responsible for Gros Morne National Park. CWS is responsible for the protection of birds.

The technical boundaries for this assessment relate primarily to the information available with regard to species at risk. There is limited research in the Gulf of St. Lawrence, on its ecosystem and its inhabitants.

### **6.7.2        Potential Interactions and Issues**

Potential interactions between Project activities and sensitive areas relate primarily to:

- Direct effect to lobster larvae nursery area and cod spawning area by noise and accidental spill events; and

- Direct effects to the coastal environment and ecosystem of Gros Morne National Park from accidental events

### 6.7.3 Significance Criteria and Evaluation

A significant adverse environmental effect for Gros Morne National Park is one that disturbs, damages, destroys or removes any living marine organism or any part of its habitat. Disturbance, damage and destruction for the purpose of this EA includes:

- an alteration of habitat physically, chemically or biologically, in quality or extent, to such a degree that there is a measurable decline in species diversity;
- mortality or serious injury to individuals of a species at risk;
- the abundance of one or more non-listed species is reduced to a level from which recovery of the population is uncertain or more than one season would be required for a locally depleted population or altered community to be restored to pre-event conditions;
- impairment of ecosystem functioning; or
- long-term or permanent displacement of any species from critical habitats.

A non-significant adverse environmental effect is one that does not meet the criteria for disturbance or damage as defined above for any living marine organism or any part of its habitat within Gros Morne National Park.

A significant adverse environmental effect on cod spawning and lobster larvae is one that is likely to cause:

- mortality or life-threatening injury to individuals of a species at risk;
- the abundance of lobster is reduced to a level from which recovery of the population is uncertain;
- long-term or permanent displacement of cod from spawning habitat; or
- destruction or adverse changes to critical or essential fish habitats.

A non-significant adverse environmental effect is one that is likely to cause on or more of the following:

- mortality or life-threatening injury of individuals in small numbers that would not adversely effect the population or the ecological functioning of the fish community; and/or

- short term displacement of individuals from preferred feeding, spawning, nursery grounds or migratory routes (including critical habitat for listed species and essential fish habitat)
- an alteration of habitat physically, chemically or biologically, in quality or extent, to such a degree that there is a measurable decline in species diversity;
- mortality or serious injury of cod;
- the abundance of cod or lobster is reduced to a level from which recovery of the population is uncertain;
- more than one season would be required for a locally depleted population or altered community to be restored to pre-event conditions;
- impairment of ecosystem functioning; or
- long-term or permanent displacement of any species from critical habitats.

#### **6.7.4 Effects Assessment and Mitigation**

The most eastern boundary of the Project Area is 8.2 km west of the North Head lobster nursery area, and 24.7 km for the Trout River Bay lobster nursery area. Both nursery areas are well beyond the influence of physical harm to lobster larvae from geophysical surveys on this Project. No mitigation is required for seismic surveys, well site surveys or VSPs related to lobster nursery areas.

The most easterly boundary of the Project Area is located about 30 km from the coastline of Gros Morne National Park. Within that distance noise will be attenuated near to ambient levels. The vessel presence will not be cumulative to the current activity of marine traffic.

The most southerly boundary of the Project Area will be 35 km (inclusive of vessel turn around) from the cod spawning area. Sound attenuation to that distance will be approaching background noise levels and well below levels reported to cause fish egg/larvae damage, mortality, injury or stunning of cod.

The impacts of oil on birds have been well documented (*e.g.*, Hartung 1995); however, no oil from discharge is expected to occur and thus, should not have any severe adverse effects of avifauna. Discharge from vessels will be standard for any marine vessel and will follow Offshore Waste Treatment Guidelines (OWTG) (NEB *et al.* 2003). Potential oil spillage may occur from ballast and bilge water discharge, however, if oil is suspected to be in the water, it will be tested and if necessary, treated using an oil/water separator to ensure that oil concentrations in the discharge do not exceed 15 mg/L as required by the MARPOL 73/78 (International Convention for the Prevention of

Pollution from Ships 1972, and the Protocol of 1978 related thereto), International Maritime Organization and OWTG.

#### **6.7.5 Follow-up and Monitoring**

Sensitive areas are categorized by the species they support. Follow-up and monitoring for those VECS are discussed in detail in the appropriate sections above.

#### **6.7.6 Cumulative Effects**

The cumulative effects of anthropogenic disturbance such as seismic surveys, oil and gas exploration, commercial fishing and shipping, along with natural process such as weather and food availability, have potential to change predator and prey abundances inside and outside the Affected Area, thus causing adverse negative effects of avifauna. However, the minimal increase in vessel traffic from this Project will be minor compared with existing vessel traffic in the area and should not significantly increase disruption to avifauna.

Routine discharges from marine vessels containing petroleum hydrocarbons could cumulatively influence avifauna. Seismic vessels used for this Project will comply with discharge regulations established by OWTG and thus should not significantly add to short-term or long-term effects of oil spillage on marine avifauna or fish/shellfish eggs and larvae.

Overall, there are no cumulative effects of this seismic exploration Project expected to occur on the distribution, abundance, breeding status and general well-being of sensitive area inside and outside the Project Area.

#### **6.7.7 Summary**

A summary of potential impacts, mitigation, residual and cumulative environmental effects is provided in Table 6.7 for routine Project activities and accidental events on sensitive areas.

**Table 6.7 Summary of Environmental Assessment for Sensitive Areas**

<b>Interactions and Issues</b>	
<ul style="list-style-type: none"> <li>▪ Direct effect to lobster larvae nursery area and cod spawning area by noise and accidental spill events; and</li> <li>▪ Direct effects to the coastal environment and ecosystem of Gros Morne National Park from accidental events</li> </ul>	
<b>Impact Analysis</b>	
<p>The Project will not interact with lobster nursery areas due to the considerable distance of survey areas. It is unlikely that the 3D surveys will take place in June and July when larvae are in the water column due to the amount of fishing activity in the offshore.</p> <p>The seismic surveys areas are well removed from the cod spawning area, in the order of 35+ km away, where noise levels will be near ambient.</p> <p>There are no documented adverse effects directly on seabirds as reported by offshore observers. Effects associated with vessel presence and lights will be similar to that marine bird and exposed to now with the considerable commercial and fishing vessel traffic. Harlequin Ducks will not interact with the Project activities spatially, and are only at risk to a spill which would dissipate well within the distance of the Project Area to the coastline</p>	
<b>Mitigation</b>	
<ul style="list-style-type: none"> <li>▪ Dedicated observer will be on board the seismic vessel to record marine birds and marine mammals.</li> <li>▪ Vessel compliant with audit prior to survey.</li> <li>▪ Compliance with OWTG (NEB <i>et al.</i> 2002) for all discharges.</li> <li>▪ Avoidance of bird colonies in Gros Morne National Park by vessel.</li> </ul>	
<b>Significance</b>	
Likelihood of occurrence	Unlikely
Geographic extent	Immediate
Frequency of occurrence	Intermittent for 20-30 days or up to 75 days for 3D program Intermittent for one week for well site survey Continuous for hours for VSP
Duration of impact	Immediate
Magnitude of impact	Low
Permanence/reversibility	Reversible
Significance	Not adversely significant
<b>Confidence</b>	
<ul style="list-style-type: none"> <li>• High level of confidence based on previous seismic surveys and research.</li> </ul>	

## 6.8 Commercial Fisheries

Commercial fisheries are important to the economy of Newfoundland and considered a VEC for this assessment due to potential interactions between the seismic vessel and fishing gear and vessels. The potential effect of underwater noise on the catchability of fish is also assessed. This impact analysis also considers potential impacts on DFO research/industry surveys. Section 6.2 assesses biological and behavioural effects on marine fish and shellfish from seismic activities.

### **6.8.1 Boundaries**

The boundary of the interaction with other users (commercial fisheries, sentinel surveys and scientific surveys) includes primarily the exclusion area surrounding the working sites, although activity of other users within the Project Area has been considered.

With respect to temporal boundaries, the potential interactions of concern are those related to the exploration drilling activities that are planned to occur intermittently between 2008 and 2015.

With regard to administrative boundaries, DFO manages the fisheries resources in the area and is primarily responsible for scientific surveys within the area. ELs 1104, 1103 fall within NAFO Unit Areas 4Rb; ELs 1098 and 1097 fall into both 4Rb and 4Rc. DFO in the Newfoundland Region manages the fisheries in the Project Area and for stock assessment of nearshore invertebrate species, snow crab and lobster. DFO Quebec Region is responsible for stock assessment of groundfish, pelagics and some offshore invertebrates (shrimp). The Department of Fisheries and Aquaculture manages aquaculture, emerging fisheries and developing fishery projects.

The technical boundaries, and the information available for this study, vary according to location of the fisheries. Georeferencing of catch is inconsistent and does not exist for inshore (coastal) fisheries and is sporadic at best for midshore fisheries, and the further offshore fisheries is incomplete. Many records are located onshore, therefore, the quality of the data is questionable.

### **6.8.2 Potential Interactions and Issues**

The seismic survey vessel and Project-related support vessel traffic will be present within 4Rb and 4Rc. Conflict with harvesting activities and fishing gear was raised as a major issue during the consultations with fishers for this assessment. Seismic streamers and vessels can conflict with and damage fishing gear, particularly fixed gear, and such conflicts typically occur three or four times a season in Atlantic Canada. Potential interactions between the Project and commercial fisheries relate primarily to:

- Behavioural changes in target species making them more difficult to catch; and
- Conflict with harvesting activities/fishing gear
- Space conflict with DFO and industry surveys

### **6.8.3 Significance Criteria and Evaluation**

A significant adverse environmental effect on commercial fisheries is defined as one that:

- excludes fishers from using 10% or more of the fishable area for the targeted species for all or most of the fishing season; and/or
- 10% or more fishers are excluded from the fishable area of the targeted species for all or most of the fishing season; and/or
- results in a measurable reduction in fisher income (profitability) or produces erroneous survey data, as a result of effects on 10% of the target marine fish populations; and/or
- causes damage to fishing gear or vessels.

A non-significant adverse environmental effect on commercial fisheries is defined as one that:

- excludes fishers from using less than 10% of the fishable area for the targeted species for all or most of the season; and/or
- less than 10% of fishers are excluded from a targeted species fishable area for all or most of the fishing season; and/or
- results in a reduction in profits due to a decrease in catchability of target species in less than 10% of the fishable area for the targeted species.

### **6.8.4 Effects Assessment and Mitigation**

#### **6.8.4.1 Space-Use Conflicts**

#### **Commercial Fishing and Research Surveys**

Commercial fish harvesting activities occur throughout the survey period, with exception of November and December, within certain portions of the Project Area, though the timing of specific fisheries varies. Of these, the fixed gear: long-line fishery, gill net fishery and pot fishery for snow crab pose the highest potential for space-use conflict, particularly if they are concurrent with seismic survey operations. For the 3-D /2-D program, the seismic vessel will operate on a 24 hour basis period for a 20 to 30 day or up to 75 day period. For the well site survey, the vessel will operate for 24 hours for one week, and the VSP survey is undertaken in less than one day and is restricted to about a 500 m radius. Because of the length of equipment towed behind the survey vessel, their manoeuvrability is restricted and other vessels must give way. Also, the 10

km turning radius, between each track line extends the assessment area beyond the 3-D/2-D survey Project Area. Therefore, fixed gear is highly susceptible to entanglement with seismic gear.

Depending on the schedule of the seismic survey, minor or moderate fisheries activity is expected within the Project Area in 2008 to 2015. Operation of the seismic survey vessel and associated support vessels may overlap with groundfish and shellfish (crab and shrimp) from May to July. Pelagic fisheries are mainly inshore. Fishers have noted that good communications, exchange of plans and gear locations, understanding of fishing practices and co-operation at sea are the keys to addressing this issue. The proponent will establish advance communications with representatives of any fisheries and DFO survey teams (4R sentinel, DFO RV and fall snow crab surveys) that may be present in the survey area on a yearly basis. Open lines of communication between the commercial fishery and the proposed seismic survey program should prevent potential adverse effects to access to fishing grounds.

### **Marine Traffic**

The majority of commercial vessel traffic occurs along the north shore of the Gulf of St. Lawrence as vessels transit to and from Montreal through the Strait of Belle Isle. The presence of the seismic vessel is predicted to have no significant effects on commercial shipping traffic. Notice to Mariners publications and communication with vessel operators will reduce the potential cumulative effects of the presence of the seismic vessel on maneuverability of commercial vessels within the proposed Project Area.

#### **6.8.4.2 Catchability Effects**

Potential effects on marine fish behaviour were assessed in Section 6.2. While adult fish could be injured by seismic arrays if they are close to an air source, this is not likely to happen as most finfish disperse when the array ramps up and becomes active, or when the vessel approaches (McCauley *et al.* 2003). Thus the most likely type of impacts will be on fish behaviour. Seismic surveys can result in reduced trawl and longline catches as the fish temporarily move from the area. There are various research studies on this subject (*e.g.*, Chapman and Hawkins 1969; Skalski *et al.* 1992; Turnpenny and Nedwell 1994; Engas *et al.* 1996). Although all indicated some impacts on fish behaviour, they reached different conclusions about the duration of the change in behaviour and/or the degree of the effect on catch. For instance, Engas *et al.* (1996) suggest that fishing for some gear types in the Barents Sea did not return to normal for at least a week after sound exposure, although the study conducted by Engas *et al.* (1996) is the only one to report effects over a large area and to show no recovery in catches (Davis *et al.* 1998, p.



99). On the St. Pierre Bank in 1999, a trawler reported experiencing decreased trawl catches after a seismic vessel began surveying in the area. The captain of a National Sea Products fishing vessel reported that, on one occasion, catch dropped from 25,000-30,000 pounds per tow, to several thousand pounds per tow, after the seismic vessel began recording. About one day later, the catch rate appeared to have returned to pre-recording levels. Fish brought to the surface in the trawl after seismic began, however, seemed more active. They also reported that after recording started, aggregations of fish were seen on the sounder, but could not be caught (Thompson *et al.* 2000b, p.15). In other instances, specific seismic surveys were not observed to have caused impacts on catches. For example, nearshore and shallow water seismic surveys in Port au Port Bay and Bay St. George, Newfoundland in 1995 and 1996 were not reported to affect catches of snow crab and other fisheries (CEF 2002, Section 7.5.2). McCauley *et al.* (2000) observed a return to normal behaviour patterns for some caged finfish within 14 to 30 minutes of the array ceasing. There are a number of reasons why studies may have reached different conclusions about the impacts of seismic noise on fish behaviour, including possible differences in species response, differences in the receiving environments (depth, seabed formations), as well as the different experimental methodologies used.

Effects on groundfish catchability are anticipated within 18 km of the seismic vessel for a 24-hour period following air source emissions. These 3-D/2-D surveys are operational for 30-40% of the time, thus there is time for recovery of catch rates. For example, a 20 to 30 day seismic program may only be operational for 12 days in total. Approximately 24 hours after air source emissions cease, catch rates within 18 km of the seismic vessel are expected to recover. Within a seismic program, it is therefore expected that fishing could occur. Based on catch data for 2004 to 2007, May to July are the months with the highest potential to affect commercial groundfish catchability. As commercial catches are quota based, the overlap between fishing and seismic activity is unknown, but will be determined prior to the commencement of the seismic program. The effects of seismic surveys on the catchability of fish were predicted to be minor, sub-local, short-term and likely to occur.

### **Avoidance of Potential Conflicts at Sea / Survey Scheduling**

Fishing industry representatives agreed that the best way to mitigate potential conflicts at sea was through good communications and information exchange. This will require careful plotting and monitoring of gear locations so they can be avoided, as well as radio communication (via the on-board Fisheries Liaison Observer) with fishers in the area. Fishing firms will exchange information with the vessel and provide plans and fixed gear co-ordinates by e-mail and fax. The survey vessel can then plot these data. This is

a mitigation measure that liaison personnel for the survey operator have employed successfully in the past.

### **Communications**

During the survey, information about the seismic program will be relayed using established communications venues, such as the Notice to Mariners, and CBC's Radio's Fisheries Broadcast, as well as direct communications between the survey vessel and fishing craft via regular VHF marine channels. NWest will also communicate, through its dedicated Fisheries Liaison Observer, with fishers at sea during the survey, to exchange information about gear and planned fishing activities, and to identify specific locations of vessels and any fixed gear that they have deployed.

Preventing any potential impact will be achieved through the exchange of information with industry participants. Because the fisheries are dynamic, there will be an annual review of catch effort data with industry representatives in the local communities. In addition, communications with relevant DFO managers will be maintained throughout the survey program. NWest will keep all parties informed about their plans and schedule. These measures will ensure that interference with RV surveys and sentinel fisheries research will be avoided or minimised.

### **Fisheries Observer**

The proponent has been in contact with the FFAW and will make the necessary arrangements to ensure that a qualified Fisheries Liaison Observer is onboard the survey vessel at all times during the survey periods.

### **Gear and Vessel Damage Compensation**

If survey operations inadvertently damage fishing gear or vessels, the NWest will implement a gear and vessel damage compensation plan to provide appropriate and timely compensation to affected fisheries participants as an alternative to claims through the courts or the C-NLOPB. This will be consistent with the C-NLOPB Compensation Guidelines Respecting Damages Relating to Offshore Petroleum Activity (March 2002). The seismic companies operating in Newfoundland waters are familiar with the compensation guidelines.

The proponent will utilise a gear and vessel damage compensation approach similar to the Hibernia models to settle promptly any claims for damage to fishing vessels or gear

caused by survey operations. (Appendix C contains standard reporting procedures to be followed by the vessel to document any such incidents).

#### **6.8.5 Follow-up and Monitoring**

Ongoing communications during the survey period will be instrumental in minimising Project effects on commercial fisheries. A Fisheries Liaison Observer onboard the seismic vessel will play a large role in communications with fishing vessels to help avoid potential conflicts at sea. Another important follow-up aspect will require scheduling of survey lines to avoid as much as possible areas where fisheries are active. The Fisheries Liaison Observer will document any contact with fishing vessels (including those outside the survey area), including the date and time, their location, and any action which may have been taken to avoid a potential conflict. Shore-based personnel or the Fisheries Liaison Observer will monitor the progress of key fisheries and completion of quotas in survey areas to facilitate line scheduling.

#### **6.8.6 Cumulative Effects**

Seismic vessels activity is a minor component of total marine transportation. Two other geophysical surveys are anticipated during 2008, compared with the thousands of commercial tanker, cargo ships, research vessels, cruise ships, fishing vessels and offshore supply vessel trips in the vicinity of the western coast of Newfoundland. The additional vessel activity from the survey is negligible compared to the other vessels and cumulative impacts on species at risk are not significant.

In general, because the sounds generated by seismic surveys are transient and do not "accumulate" in the environment, the most likely cumulative effects will be associated with other concurrent activities (*e.g.*, cargo ships, tankers, oil and gas exploration and production activities, other seismic surveys, fishing vessels). Studies in the Gulf of Mexico showed that seismic surveys produce a relatively minor contribution to the overall underwater noise environment (MMS 2004). The cumulative effect is short term, intermittent and localised, and therefore, not significant with respect to affects on commercial fisheries or scientific research surveys.

Two seismic exploration projects will be active in the vicinity of the Project Area. PDI Productions Inc. was to commence work in the fall of 2007 in the Port au Port area (EL 1070) but if the Project undergoes unavoidable delays, the seismic work could be undertaken anytime in the next three years. Tekoil and Gas Corp. is conducting seismic work over part of, and adjacent to, the Port au Port Peninsula (EL 1071) during a six-

week period from October 2008 to April 2009. If these other seismic surveys being conducted on the west coast within the proposed timeframe, a significant distance between surveys will be necessary to prevent both operational conflict and acoustical interference. This will reduce or eliminate the likelihood that the sound levels from two surveys will be additive in a particular area, and reduce the potential for cumulative effects on species at risk. The location of these two surveys are in the same location and are 68.5 km south the most southern boundary of the Project Area and 143 km from Seismic Survey Area 1. There will be no spatial overlap between these projects and the NWest Project.

### 6.8.7 Summary

A summary of potential interactions, effects, mitigation, residual and cumulative environmental effects is provided in Table 6.8.

**Table 6.8 Summary of Environmental Assessment for Species at Risk**

<b>Interactions and Issues</b>	
<ul style="list-style-type: none"> <li>• Presence of seismic vessel causing loss of access and/or gear entanglement.</li> <li>• Noise from seismic recording causing behavioural changes result in reduced catchability.</li> <li>• Space conflict with DFO and industry surveys</li> </ul>	
<b>Impact Analysis</b>	
Potential adverse environmental effects on commercial fisheries will be mitigated through the implementation of various proven mitigative measures, including: enhanced communications with fishing industry representatives and individual fishing vessels; use of a Fisheries Liaison Observer; monitoring of gear locations and research survey locations; scheduling of survey lines to minimise potential conflicts with harvesting and research activities; and, as required, implementation of a gear and vessel damage compensation contingency plan.	
<b>Mitigation</b>	
<ul style="list-style-type: none"> <li>• Avoidance of fishing gear through communication</li> <li>• Notice to Mariners on the location and scheduling of seismic activities</li> <li>• Dedicated FLO onboard</li> <li>• Develop communication mechanisms with the fishing industry and research programs; and</li> <li>• Comply with C-NLOPB's guidelines respecting compensation.</li> </ul>	
<b>Significance</b>	
Likelihood of occurrence	Medium
Geographic extent	Immediate
Frequency of occurrence	Intermittent for the 3-D/2-D program ( 20-30 days or up to 75 days) Intermittent for the well site survey (one week) Continuous for the VSP ( hours)
Duration of impact	Immediate
Magnitude of impact	Medium
Permanence/reversibility	Reversible, immediate recovery after Project activities cease or compensation awarded.
Significance of Effects	Not adversely significant

## 7.0 EFFECTS OF THE ENVIRONMENT ON THE PROJECT

### 7.1 Meteorology and Oceanography

Extreme conditions may affect schedule and program operations. Seismic surveys (data quality) are limited by waves in excess of three metres. Meteorological and oceanographic monitoring through weather forecasting services will be undertaken to anticipate severe weather conditions.

### 7.2 Sea Ice and Icebergs

Icebergs of Newfoundland and Labrador typically do not extend into the Gulf of St; Lawrence as far south as the Affected Area. The seismic surveys will be undertaken during the ice-free season to protect the cables and subsequently the environment.

## 8.0 ENVIRONMENTAL MANAGEMENT

Appendix D contains the NWest Energy Inc Environmental Stewardship Plan, Emergency Response Plan and fishers gear conflict protocol. The company will follow the C-NLOPB Compensation Guidelines Respecting Damages Relating to Offshore Petroleum Activity.

## 9.0 SUMMARIES AND CONCLUSIONS

### 9.1 Zones of Influence

The EA Report includes prediction of sound levels off vertical based on spherical and cylindrical spreading transmission loss at various distances from the array source over water depths in the Project Area. Table 9.1 presents a summary of observed effects on marine animals from sound levels and the distances those effects could be exhibited from the Project at 45° and 0° from horizon (both crossline and inline). There are no underwater sound level criteria for marine birds.

**Table 9.1 Predicted Zones of Influence and Direct and Indirect Effects on Marine Species Expected in the Affected and Regional Areas at 0° and 45° Angles of Emission**

Species	Effects	Sound Level (RMS)	Predicted Distance From Source in 150 m Water Depth	
			45°	0° Off Horizon
marine fish	transient stunning	192 dB re 1µPa	4-32 m	1 m
marine fish	internal injuries	200 dB re 1µPa	2-16 m	< 1 m
marine fish	egg/larval damage	220 dB re 1 µPa	1 m	<1 m
marine fish	mortality	230-240 db re 1µPa	<1 m	<1 m
marine mammals	temporary threshold shift	200-205 dB re 1 µPa	2-6 m	1 m
cetaceans	harassment	180 dB re 1 µPa	16-128 m	1 m
pinnipeds	harassment	190 dB re 1 µPa	8-32 m	1 m
marine mammals	strong avoidance	160-170 dB re 1 µPa	64 m - 16 km	32 m
marine turtles	avoidance	166 dB re µPa	128 m - 4 km	32 m
marine turtles	erratic behaviour	175 dB re µPa	32 m - 1 km	8 m

### 9.2 Summary of Mitigation and Follow-Up

Table 9.2 summarises mitigating measures and follow-up procedures that are recommended in this EA Report.

**Table 9.2 VEC-Specific Mitigative Measures and Follow-Up**

VEC	Mitigation Measures	Follow up and Monitoring
Marine and Migratory Birds	<p>Compliance with NWest WMP, <i>Canada Shipping Act</i>, OWTG and MARPOL for all discharges.</p> <p>A fuel transfer plan will be developed and implemented.</p> <p>Solid streamers will be used. Any handling of stranded birds will follow CWS and industry protocols.</p> <p>A dedicated Environmental Observer will be on board the seismic vessel to record marine birds.</p> <p>Vessel compliant with audit prior to survey. Maintenance of streamer equipment and responsible management of such equipment. Avoidance of bird colonies in Gros Morne National Park by vessel.</p>	<p>Sightings data for seabirds, will be summarised in a monitoring report which will be submitted to C-NLOPB and CWS.</p> <p>Records of bird strandings will be provided to the C-NLOPB for distribution to interested parties.</p>
Marine Fish and Shellfish	<p>Sensitive areas and sensitive time periods (<i>i.e.</i>, cod spawning, lobster nursery areas and major concentrations of fisheries, will be avoided.</p> <p>Adherence to the <i>Statement of Canadian Practice on the Mitigation of Seismic Noise in the Marine Environment</i>, to the extent reasonably practical.</p> <p>To minimize sudden changes in noise levels, a 30 minute ramp up procedure will be implemented.</p>	<p>No follow up or monitoring required for routine activities</p>
Marine Mammals	<p>Before start of the operations, a meeting will be held with NWest representatives and seismic company representatives to review sail lines, scheduling, anticipated fishing vessels and gear types, mitigating measures, expectations of all parties and Emergency Response Plans.</p> <p>An Environmental Observer will be onboard the vessel throughout the duration of the survey.</p> <p>The Fisheries Liaison Observer and Environmental Observer will record sightings of marine mammals on a daily basis as per protocol.</p>	<ul style="list-style-type: none"> <li>• A trained observer will record marine mammal and seabird observations.</li> <li>• All spills will be reported.</li> </ul>



**Table 9.2 VEC-Specific Mitigative Measures and Follow-Up**

VEC	Mitigation Measures	Follow up and Monitoring
	<p>A 20 to 40 minute ramp-up procedure will be undertaken.</p> <p>Ramping up will be delayed if a marine mammal is observed in the 500 m safety zone.</p> <p>Air sources will be shut down or reduced to a smaller air source while the vessel is doing turns between survey lines.</p> <p>The Environmental Observer will ensure the delay or shut down of seismic operations if endangered or threatened whales are present within 500 m.</p> <p>Any re-start of the air source array will follow the ramping up procedure.</p> <p>Collision avoidance practices, including constant speed and course maintained by seismic and support vessels.</p> <p>Vessels will maintain a steady course and speed, and use existing travel routes, where possible.</p>	
Marine Turtles	<p>MARPOL standard procedures</p> <p>The Fisheries Liaison Observer and Environmental Observer will record sightings of sea turtles on a daily basis as per protocol.</p> <p>A 20 to 40 minute ramp-up procedure will be undertaken.</p>	<p>A trained observer will record sea turtle observations.</p> <ul style="list-style-type: none"> <li>• All spills will be reported.</li> </ul>
Species at Risk	<p>Adherence to the <i>Statement of Canadian Practice on the Mitigation of Seismic Noise in the Marine Environment</i> to the extent reasonably practical.</p> <p>Same as above for marine birds, marine turtles and marine mammals</p>	<p>A trained observer will record marine mammal, sea turtles and seabird observations.</p> <ul style="list-style-type: none"> <li>• All spills will be reported.</li> </ul>
Sensitive Areas	<p>Dedicated Environmental Observer will be on board the seismic vessel to record marine birds and marine mammals.</p> <p>Vessel compliant with audit prior to survey.</p> <p>Maintenance of streamer equipment and responsible management of such equipment.</p> <p>Compliance with OWTG (NEB <i>et al.</i> 2002) for all discharges.</p> <p>Avoidance of bird colonies in Gros Morne National Park by vessel.</p>	<p>No follow up or monitoring required for routine activities</p> <p>All spills will be reported.</p>
Commercial	A Notice to Mariners on the location and	No follow up or monitoring

**Table 9.2 VEC-Specific Mitigative Measures and Follow-Up**

<b>VEC</b>	<b>Mitigation Measures</b>	<b>Follow up and Monitoring</b>
Fisheries	<p>scheduling of seismic activities will be issued.</p> <p>Communication mechanisms will be developed with the fishing industry and DFO research surveys.</p> <p>Environmental Observers on the vessel will monitor fishing activity in the vicinity of the seismic vessel and serve as a liaison between the fishing vessels and the seismic vessel; NWest will comply with C-NLOPB's compensation guidelines.</p>	required for routine activities

**9.2.1 Scheduling**

Timing is one of the more effective mitigation measures. Although the EA determined that the NWest Program would not result in any significant adverse impacts to the VECs, it is prudent to consider the seasonality and seasonal sensitivity of commercially and ecologically important resources in the Project and Affected Areas to reduce the number of interactions. Table 9.3 summarises sensitive periods in the Project Area.

**Table 9.3 Schedules of Important Commercial Fishing Activity and Ecologically Important Species in the Project Area**

<b>Resource</b>	<b>Most Important Time</b>
Whales	Most migrating into the Gulf in spring and out migrate in fall to southern waters
Sea turtles	Migrating into the Gulf in spring and out migrate in fall to southern waters
Fish eggs and larvae	Least abundant in September to October
Lobster larvae	Summer
Cod Spawning	April to May, juveniles demersal by September
Marine Birds	Low numbers, April to September, least abundant October to December
4R Sentinel Survey	July 1- July 15
DFO RV Survey	August
Shrimp	April to October
Snow crab	April to July
Mackerel	August to October
Herring	August to December
Capelin	June and July
Turbot	May to July
Halibut	May to August

The optimal time period for the NWest 3-D/2-D Program to proceed is in August to December when the majority of the commercial fisheries have obtained their quotas, and most of the DFO research surveys are concluded. This consideration, however, must be balanced with logistics such as availability of seismic vessels.

### 9.3 Conclusions

The Project Area is not known to be an important feeding, rearing or mating area for any of the listed species that could occur in the area. Commercial fishing occurs in the ice-free period in the Activity Area and only effective and frequent communication will resolve space conflict issues. With the use of appropriate mitigation, all Project effects have been rated as not adversely significant. Most of the species that could occur in the Project Area are more vulnerable to direct and indirect fishing activities; entanglement in fishing gear; collisions with ships; and/or pollution. As described in this report, all appropriate mitigation measures and response planning will be in place to limit pollution as a result of the Project; vessel activity will generally be restricted to the immediate Project Area; and noise levels associated with the Project are not predicted to result in physical harm to marine birds, marine fish/shellfish, marine mammals, or sea turtles. Previous 2-D seismic surveys conducted in this area have not resulted in claims that significant adverse effects to biological or socio-economic VECs of the area. Based on the above, no harm to listed species or their critical habitat is anticipated to occur as a result of the Project at any time of year. This is consistent with the recent review by the Mineral Management Service (2004) on environmental effects of seismic activities in the Gulf of Mexico, which have shown that adverse significant effects from a much larger number of seismic programs are not apparent beyond the immediate localised project areas.

The significance of residual environmental effects (*i.e.*, after mitigation has been applied), including cumulative effects, is predicted not likely to be significantly adverse for all VECs. In conclusion, this environmental assessment predicts that NWest's proposed 3-D seismic program and geophysical surveys can be conducted with no likely significant adverse effects on the biological and socio-economic resources of the west coast of Newfoundland.

## 10.0 REFERENCES

Ahrens, M.A. 1993. Atlantic herring. Underwater world. Department of Fisheries and Oceans, Ottawa. 8 pp.

Amoser, S. and F. Ladich. 2003. Diversity in noise-induced temporary hearing loss in otophysine fishes. *Journal of the Acoustical Society of America* 113(4): 2170-2179.

Armstrong, D.A., P.A. Dinnel, J.M. Orensanz, J.L. Armstrong, T.L. McDonald, R.F. Cusimano, R.S. Nemeth, M.L. Landolt, J.R. Skalski, R.F. Lee and R.J. Huggett. 1995. Status of Selected Bottomfish and Crustacean Species in Prince William Sound Following the Exxon Valdez Oil Spill. pp. 485-547. In: P.G. Wells, J.N. Butler and J.S. Hughes (eds.), *Exxon Valdez oil spill: fate and effects in Alaskan waters*, ASTM STP 1219. American Society for Testing and Materials, Philadelphia. 965 p.

Arnold, B.W. 1996. Visual monitoring of marine mammal activity during the Exxon 3-D seismic survey/Santa Ynez Unit, offshore California/9 November to 12 December 1995. Rep. from Impact Sciences Inc., San Diego, CA, for Exxon Co. U.S.A., Thousand Oaks, CA. 25 p

Atlantic Leatherback Turtle Recovery Team 2006. Recovery Strategy for Leatherback Turtle (*Dermochelys coriacea*) in Atlantic Canada. Species at Risk Act Recovery Strategy Series. Fisheries and Oceans Canada, Ottawa, vi + 45 pp.

Au, W. W. L. and P. W. B. Moore. 1990. Critical ratio and critical bandwidth for the Atlantic bottlenose dolphin. *Journal of the Acoustical Society of America* 88, 1635-1638.

Au, W.W.L, and P.W.B Moore 1988. Detection of complex echoes in noise by an echolocating dolphin *Journal of the Acoustical Society of America* 103:41-47

Au, W.W.L. 1993. *The Sonar of Dolphins*. Springer-Verlag, New York, NY, 277 pp.

Au, W.W.L., D.D., Carder, R.H. Penner and B.L. Scronce. Demonstration of adaptation in beluga whale echolocation signals *Journal of the Acoustical Society of America* 77:726-730

Au, W.W.L., R.W. Floyd., R.GZH. Penner and A.E. Murchison.1974. Measurement of echolocation signals of the Atlantic bottlenose dolphin, *Tursiops truncatus Montagu*, in open waters. *Journal of the Acoustical Society of America* 56:1280-1290

Austin D.A, Bowen W.D, McMillan J.I. 2004. Intraspecific variation in movement patterns: modeling individual behaviour in a large marine predator. *Oikos*:105:15-30.

Barrie, J. and S. Browne. 1980. Nearshore studies of marine benthos in the Makkovik Bay and Cartwright regions. pp. 154-173. In: Proceedings 1980 Workshop on Research in the Labrador Coastal and Offshore Region, Goose Bay, Labrador, Sept. 4-6, 1980. Sponsored by Memorial University, Newfoundland and Labrador Dept. of Mines and Energy, and Petro-Canada.

Beanlands, G.E. and N.P. Duinker. 1983. An Ecological Framework for Environmental Impact Assessment in Canada. Institute for Resource and Environmental Studies. Dalhousie University, Halifax, NS and Federal Environmental Assessment Review Office.

Bedford Institute of Oceanography, 2003. Monthly current statistics. Online: [http://www.mar.dfo-mpo.gc.ca/science/ocean/current\\_statistics/so54n](http://www.mar.dfo-mpo.gc.ca/science/ocean/current_statistics/so54n)

Bird Studies Canada. Online: <http://www.bsc-eoc.org>

Blaxter, J.H.S., J.A.B. Gray, and E.J. Denton. 1981. Sound and startle responses in herring shoals. *Journal of the Marine Biological Association of the United Kingdom* 61: 851-869.

Blomquist, S. and M. Peterz. 1984. Cyclones and pelagic seabird movements. *Mar. Ecol. Prog. Ser.* 20:85-92.

Boulva, J. and I. A. McLaren. 1979. Biology of the harbor seal, *Phoca vitulina*, in eastern Canada. *Bulletin of the Fisheries Research Board of Canada* 200:1-24.

Bowles, A.E., M. Smultea, B. Würsig, D.P. DeMaster and D. Palka. 1994. Relative abundance and behavior of marine mammals exposed to transmissions for the Heard Island feasibility test. *Journal of the Acoustical Society of America* 96: 2469-2484.

Breeze, H., D.G. Fenton, R.J Rutherford and M.A. Silva. 2002. The Scotian Shelf: an ecological overview for ocean planning. Canadian Technical Report on Fisheries and Aquatic Sciences 2393.

Brown, R.G.B. 1986. Revised Atlas on Canadian Seabirds. Canadian Wildlife Service. Dartmouth, N.S. 111 pp.

Cairns, D.K., W.A. Montevecchi and W. Threlfall. 1989. Researcher's guide to Newfoundland seabird colonies. Second edition. Memorial University of Newfoundland Occasional Papers in Biology, No. 14. 43 pp.

Calambokidis, J. and S.D. Osmeck. 1998. Marine mammal research and mitigation in conjunction with air gun operation for the USGS 'SHIPS' seismic surveys in 1998. Draft Report from Cascadia Research, Olympia, WA, for United States Geological Survey, National Marine Fisheries Service, and Minerals Management Service

Campbell, J. and N. Sutterlin. 1981. Grand Banks bibliography. Unpubl. Report to Petro-Canada, St John's, Newfoundland. 47 pp.

Canadian Environmental Assessment Agency (CEA) 1997. Guide to the Preparation of a Comprehensive Study for Proponents and Responsible Authorities.

Canadian Environmental Assessment Agency (CEA) 1994. The Responsible Authority's Guide to the Canadian Environmental Assessment Act. Environment Canada. Hull, Quebec.

Canadian Nature Federation. Online: [www.ibacanada.com](http://www.ibacanada.com).

Castonguay, M., C. Rollet, A. Fréchet, P. Gagnon, D. Gilbert, and J.-C. Brêthes. 1999. Distribution changes of Atlantic cod (*Gadus morhua* L.) in the northern Gulf of St. Lawrence in relation to an oceanic cooling. International Council for the Exploration of the Sea (ICES) Journal of Marine Science 56: 333-344.

Catto, N.R., R.G. Hooper, M.R. Anderson, D.A. Scruton, J.D. Meade, L.M.N. Ollerhead, and U.P. Williams. 1999. Biological and geomorphological classification of Placentia Bay: A preliminary assessment. Canadian Technical Report on Fisheries and Aquatic Sciences 2289.

Canada-Newfoundland and Labrador Offshore Petroleum Board (CNLOPB) 2002. Compensation Guidelines Respecting Damages Relating to Offshore Petroleum Activity.<http://www.cnlopb.nl.ca>. 19 pp.

Canada-Newfoundland and Labrador Offshore Petroleum Board (CNLOPB) 2004. Geophysical, Geological, Environmental and Geotechnical Program Guidelines, Newfoundland Offshore Area .<http://www.cnlopb.nl.ca/> 35 pp.

Canada-Nova Scotia Offshore Petroleum Board (CNSOPB) 2002. Strategic Environmental Assessment of Potential Exploration Rights Issuance for Eastern Sable Island Bank, Western Banquereau Bank, the Gully Trough and Eastern Scotian Slope. CNSOPB, Halifax, NS.

CEF Consultants Ltd. (CEF) 2002. Environmental Impact Assessment of a 2D Seismic Survey in Sydney Bight. Prepared for Hunt Oil Company of Canada, on behalf of Hunt Oil Company and Total Final Elf E&P Canada Ltd. 146 pp + appendices

Chaffey, H. 2003. Integrating scientific knowledge and local ecological knowledge about common eiders (*Somateria mokissima*) in southern Labrador. M.S. Thesis. Memorial University of Newfoundland. St. John's.

Chapman, C.J., and A.D. Hawkins. 1969. The importance of sound in fish behaviour in relation to capture by trawls. P717-729 *In*: A. Ben-Tuvia and W. Dickson (eds.), Proceedings of the FAO conference on fish behaviour in relation to fishing techniques and tactics. 19-27 Oct 1967. FAO Fisheries Report 62 (3), Rome.

Christian, J.R., A. Mathieu, D.H. Thomson, D. White and R.A. Buchanan. 2004. Effect of seismic energy on snow crab (*Chionoecetes opilio*) 7 November 2003. Environmental Studies Research Funds Report No. 144. Calgary. 106 pp.

Committee on the Status of Endangered Wildlife in Canada 2004. COSEWIC assessment and status report on the porbeagle shark *Lamna nasus* in Canada. Committee on the Status of Endangered Wildlife in Canada. Ottawa. viii + 43 pp. ([www.sararegistry.gc.ca/status/status\\_e.cfm](http://www.sararegistry.gc.ca/status/status_e.cfm)).

Corwin, J.T. and D.A. Cotanche. 1988. Regeneration of sensory hair cells after acoustic trauma. *Science* 240. no. 4860: 1772-1774

COSEWIC 2005. COSEWIC assessment and update status report on the fin whale *Balaenoptera physalus* in Canada. Committee on the Status of Endangered Wildlife in Canada. Ottawa. ix + 37 pp. ([www.sararegistry.gc.ca/status/status\\_e.cfm](http://www.sararegistry.gc.ca/status/status_e.cfm)).

COSEWIC 2006d. COSEWIC assessment and update status report on the Ivory Gull (*Pagophila eburnea*) in Canada. Committee on the Status of Endangered Wildlife in Canada. Ottawa. 42 pages.

COSEWIC. 2003. COSEWIC Assessment and Update Status Report on the Humpback Whale *Megaptera novaeangliae* in Canada: North Pacific Population; Western North

Atlantic Population. Committee on the Status of Endangered Wildlife in Canada, Ottawa, ON. 25 pp.

Dahlheim, M.E 1987. Bio-acoustics of the gray whale (*Eschrichtius robustus*). Ph.D. Thesis, University of British Columbia, Vancouver, BC. 315 p.

de Lafontaine, Y. 1990. Ichthyoplankton communities in the St. Lawrence estuary: composition and dynamics. *In: Oceanography of a large-scale estuarine system: the St. Lawrence, coastal and estuarine studies*. M. El-Sabh and N. Silverberg (eds.), Coastal and Estuarine Studies, No. 39, Springer-Verlag, New York. P. 321-343.

de Lafontaine, Y., S. Demers, and J. Runge. 1991. Pelagic food web interactions and productivity in the Gulf of St. Lawrence: A perspective. pp. 99-123. *In: J-C. Therriault (ed.). The Gulf of St. Lawrence: small ocean or big estuary? Canadian Special Publication of Fisheries and aquatic Sciences* 113.

Davies, D.M. and J.S. Bell. 1984. A comparison of the levels of hepatic aryl hydrocarbon hydroxylase in fish caught close to and distant from North Sea oil fields. *Marine Environmental Research* 14:23-45.

Davis, R.A., D.H. Thomson and C.I. Malme. 1998. Environmental assessment of seismic exploration on the Scotian Shelf. Prepared for Mobil Oil Canada Properties Ltd., Shell Canada Ltd., and Imperial Oil Ltd. for the Canada-Nova Scotia Offshore Petroleum Board, Halifax.

Dempsey, J., A. Simms, J. Harper, E. Lambert, and R. Hooper. 1995. West coast Newfoundland oil spill sensitivity atlas. ESRF Report No. 127.

DFO (Fisheries and Oceans Canada). 2006a. Assessment of shrimp status in the Estuary and Gulf of St. Lawrence in 2006. Canadian Science Advisory Secretariat Science Advisory Report 2007/006. 12 pp.

DFO (Fisheries and Oceans Canada). 2006b. Statement of Canadian Practice for Mitigation of Seismic Noise in the Marine Environment. [http://www.dfo-mpo.gc.ca/oceans-habitat/oceans/im-gi/seismic-sismique/statement-enonce\\_e.asp](http://www.dfo-mpo.gc.ca/oceans-habitat/oceans/im-gi/seismic-sismique/statement-enonce_e.asp)

DFO (Fisheries and Oceans Canada) 2005a. The Northern Gulf of St. Lawrence (3Pn, 4RS) cod in 2004. Science Advisory Report 2005/003.



DFO (Fisheries and Oceans Canada). 2005b. Capelin of the Estuary and Gulf of St. Lawrence (4RST) in 2004. DFO Canadian Science Advisory Secretariat Science Advisory Report 2005/002.

DFO (Fisheries and Oceans Canada). 2005c. Stock assessment report on Newfoundland and Labrador snow crab. DFO Canadian Science Advisory Secretariat Science Advisory Report 2005/017.

DFO (Fisheries and Oceans Canada) 2005d. Gulf of St. Lawrence (4RST) Greenland Halibut in 2004. Science Advisory Report 2005/012.

DFO (Fisheries and Oceans Canada). 2005e. Atlantic halibut of the Gulf of St. Lawrence (4RST) in 2004. Science Advisory Report 2005/31.

DFO (Fisheries and Oceans Canada). 2004a. Unit 1 redfish - 2003 update. Stock Status Report 2004/15.

DFO (Fisheries and Oceans Canada). 2004b. Allowable harm assessment for spotted and northern wolffish. DFO Canadian Scientific Advisory Secretariat Stock Status Report 2004/031.

DFO (Fisheries and Oceans Canada). 2004c. Review of scientific information on impacts of seismic sound on fish, invertebrates, marine turtles and marine mammals. Habitat Status Report 2004/002. September 2004. 15 pp.

DFO (Fisheries and Oceans Canada). 2004d. Potential impacts of seismic energy on snow crab. Habitat Status Report 2004/003. October 2004.

DFO (Fisheries and Oceans Canada). 2004e. Shrimp of the Estuary and Gulf of St. Lawrence in 2003. DFO Science, Stock Assessment Section, Stock Status Report 2004/009.

DFO (Fisheries and Oceans Canada). 2003. Statistical Profile, Number of Fishing Licences, 2003, Newfoundland and Labrador Region. Regional Licensing Office Fisheries Management Branch (Data as of December 31, 2003).

Dunbar, M.J., D.C. Maclellan, A. Filion, and D. Moore. 1980. The biogeographic structure of the Gulf of St. Lawrence. Marine Sciences Centre, McGill University, Montreal. 142 pp.

- Duncan, P.M. 1985. Seismic sources in a marine environment. pp. 56-88. In: Proc. Workshop on Effects of Explosives Use in the Marine Environment, Jan. 1985, Halifax, Nova Scotia Technical Report 5. Canadian Oil & Gas Lands Administration, Environmental Protection Branch, Ottawa, ON. 398 p.
- Dutton, P.H., B.W. Bowen, D.W. Owens, A. Barragan and S.K. Davis. 1999. Global phylogeography of the Leatherback Turtle (*Dermochelys coriacea*). Journal of Zoology (London) 248: 397-409.
- Eckert S.A., Eckert, K.L., Ponganis, P. and Kooyman, G.L. 1989. Diving and foraging behavior of leatherback sea turtles (*Dermochelys coriacea*). Canadian Journal of Zoology 67, 2832-2840
- Engås, A, S. Løkkeborg, E. Ona and A.V. Soldal. 1996. Effects of seismic shooting on local abundance and catch rates of cod (*G. morhua*) and haddock (*M. aeglefinus*). Canadian Journal of Fisheries and Aquatic Sciences 53(10):2238-2249.
- Engen, F., and I. Folstad. 1999. Cod courtship song: a song at the expense of dance? Canadian Journal of Zoology 77: 542-550.
- Enger, P.S. 1981. Frequency discrimination in teleosts-central or peripheral?. pp. 243-253. In: W.N. Tavolga, A.N. Popper and R.R. Fay. (eds.). Hearing and sound communication in Fishes. Springer-Verlag New York.
- Environment Canada, 1984. A Summary of Trends Relating to Spills of Oil and Hazardous Materials in the Atlantic Region, 1981 and 1982. Surveillance Report EPS-5-AR-84-5. Atlantic Region.
- Environment Canada. 2007. Management Plan for the Harlequin Duck (*Histrionicus histrionicus*) Eastern Population, in Atlantic Canada and Québec. Species at Risk Act Management Plan Series. Environment Canada. Ottawa. vii + 32 pp.
- Ernst, C.H., R.W. Barbour and J.E. Lovich (eds). 1994. Turtles of the United States and Canada. Smithsonian Institution Press, Washington, DC. 578 pp.
- Evans, P.G.H., E.J. Lewis, E. Parsons and C. Swann. 1993. A Survey of Whales and Dolphins in Hebridean Waters. Sea Watch Foundation, Oxford.

- Falk, M.R., and M.J. Lawrence. 1973. Seismic exploration: its nature and effects on fish. Canadian Fisheries and Marine Service Technical Report CEN/T-73-9. Resource Management Branch, Fisheries Operations Directorate, Central Region, Winnipeg, 51 pp.
- Finneran, J.J., C.E. Schlundt, R. Dear, D.A. Carder and S.H. Ridgway. 2002. Temporary Shift in Masked Hearing Thresholds in Odontocetes after Exposure to Single Underwater Impulses from a Seismic Watergun. *Journal of the Acoustical Society of America* 111(6): 2929-2940.
- Fisheries and Oceans Canada. 2000. Canadian North Atlantic Right Whale Recovery Plan. <http://www.baleinesendirect.net/eng/FSC.html?sct=2&pag=2-4-5.html>. 104 pp.
- Frank, K.T. and W.C. Leggett. 1981. Wind regulation of emergence times and early larval survival in capelin (*Mallotus villosus*). *Canadian Journal of Fisheries and Aquatic Sciences* 38: 215-223.
- Fréchet, A., J. Gauthier, P. Schwab, H. Bourdages, D. Chabot, F. Collier, F. Grégoire, Y. Lambert, G. Moreault, L. Pageau, and J. Spingle. 2003. The status of cod in the Northern Gulf of St. Lawrence (3Pn, 4RS) in 2002. Canadian Science Advisory Secretariat Research Document 2003/065.
- Gaston, A.J. and I.L. Jones. 1998. *The Auks. Bird Families of the World*. Oxford Univ. Press, NY. 349 pp.
- Gauthreaux, Jr. S.A., and C.G. Belser. 2006. Effects of artificial night lighting on migrating birds, pg 67-93. In: *Ecological Consequences of Artificial Night Lighting*. Rich C and T. Longeore (eds.) Island Press 480 pp.
- Gilkinson, K. 1996. Review and assessment of the literature on marine benthic mollusks (*Amphineura*, *Bivalvia*, *Gastropoda*) in Newfoundland and Labrador waters. *NAFO Science Council Studies*, 10:93-108.
- Goff, G.P. and J. Lien. 1988. Atlantic leatherback turtles, *Dermochelys coriacea*, in cold water off Newfoundland and Labrador. *Canadian Field-Naturalist* 102(1):1-5.
- Gooddall C, Chapman C. and Neil, D. 1990. The acoustic response threshold of the Norway lobster, *Nephrops norvegicus* (L.) in a free sound field. In: Wieses, K., Krenz, W.D., Tatz, J., Reichert, H., Mulloney, B. (eds) *Frontiers in crustacean neurobiology*. Birkhäuser, Basel. Pp 106-113.

Goold, J.C. 1996a. Acoustic assessment of common dolphins off the west Wales coast, in conjunction with 16th round seismic surveying. Rep. to Chevron UK Ltd, Repsol Exploration (UK) Ltd and Aran Energy Exploration Ltd from School of Ocean Sciences, University of Wales, Bangor, Wales. 22 pp.

Goudie, R.I. 1991a. Eider ducks and gulls: is there a problem? *Atlantic Society of Fish & Wildlife Biologists* 7(1): 24-26.

Goulet, A.-M., Hammill, M.O., and Barrette, C. 2001. Movements and diving activities of grey seal females (*Halichoerus grypus*) in the Gulf of St. Lawrence, Canada. *Polar Biol.* 24: 432-439.

Government of Canada. 2005. Species at Risk Act Public Registry. Available at <http://www.sararegistry.gc.ca>, accessed November 16, 2005.

Government of Newfoundland and Labrador. 2007. Energy Plan. Available at <http://www.nr.gov.nl.ca/energyplan/EnergyReport.pdf>

Greene, C.R., Jr. and M.W. McLennan. 2000. Sound levels from a 1210 cu. in. air gun array. pp. 3-1-3-9. *In*: W.J. Richardson (*ed.*), Marine mammal and acoustical monitoring of Western Geophysical's open-water seismic program in the Alaskan Beaufort Sea, 2000: 90-day report. Report TA2424-3. Report from LGL Ltd., King City, Ont., and Greeneridge Sciences Inc., Santa Barbara, CA, for Western Geophysical, Anchorage, AK, and National Marine Fisheries Service, Anchorage, AK, and Silver Spring, MD. 121 pp.

Hammill, M.O. 1993. Seasonal movements of hooded seals tagged in the Gulf of St. Lawrence, Canada. *Polar Biol.* 13:307-310.

Hardy & Associates. 1985. Evaluation of biological community studies of the southern and southeastern Newfoundland shoreline. Report by Hardy Associates (1978) Ltd. to Petroleum Directorate, Government of Newfoundland and Labrador, St John's, Newfoundland. 251 pp.

Hartung, R. 1995. Assessment of the Potential for Long-term Toxicological Effects of the Exxon Valdez Oil Spill on Birds and Mammals. pp. 693-725. *In*: P.G. Wells, J.N. Butler and J.S. Hughes (eds.), Exxon Valdez oil spill: fate and effects in Alaskan waters, ASTM STP 1219. American Society for Testing and Materials, Philadelphia. 965 pp.

Harvey, V. 2007. Utilisation de l'habitat à différentes échelles spatiales et temporelles par le phoque gris de l'Atlantique Nord-ouest. M.Sc. Laval University, Québec, Qc. 76 pp.

Hassel, A., T. Knutsen, J. Dalen, S. Løkkeborg, K. Skaar, Ø. Østensen, E.K. Haugland, M. Fonn, Å. Høines and O.A. Misund. 2003. Reaction of sandeel to seismic shooting: A field experiment and fishery statistics study. Institute of Marine Research, Bergen, Norway.

Hastings, M. C. 1990. Effects of Underwater Sound on Fish. Document No. 46254-900206-01IM, Project No. 401775-1600, AT&T Bell Laboratories.

Hawkins, A. D. & Amorim, M. C. P. 2000. Spawning sounds of the male haddock, *Melanogrammus aeglefinus*. Environmental Biology of Fishes 59: 29-41.

Holliday, D.V., R.E. Pieper, M.E. Clarke and C.F. Greenlaw. 1987. The effects of airgun energy releases on the eggs, larvae, and adults of the northern anchovy (*Engraulis mordax*). API Publication 4453. Report by Tracor Applied Sciences for American Petroleum Institute, Washington, DC. 115 pp.

IMG-Golder Corp. 2002. Behavioural and physical response of riverine fish to airguns. Report prepared for WesternGeco, Calgary, Alberta.

Innovation Newfoundland and Labrador: A Blueprint for Prosperity, 2006. Online: <http://www.intrd.gov.nl.ca/intrd/Innovation/Full%20Report.pdf>

International Convention for the Prevention of Pollution from Ships, 1972. Online:[http://www.imo.org/Conventions/contents.asp?doc\\_id=678&topic\\_id=258](http://www.imo.org/Conventions/contents.asp?doc_id=678&topic_id=258)

Jacques Whitford Limited, 2006. Port au Port Seismic Program Screening and Registration. Prepared for Tekoil and Gas Corporation. 145 pp + appendices.

Jacques Whitford Limited, 2005. Seismic Exploration Program Environmental Assessment for Exploration Lease 1069. Prepared for Ptarmigan Resources Ltd. 165 pp + appendices

Jochens, A.E. and D.C. Biggs, editors. 2003. Sperm whale seismic study in the Gulf of Mexico. Annual report: Year 1. U.S. Department of the Interior, Minerals Management Service, Gulf of Mexico OCS Region, New Orleans, LA. OCS Study MMS 2003-069. 139 pp. Available at: <http://www.gomr.mms.gov/homepg/regulate/envIRON/studies/2003/2003-069.pdf>.

Josenhans, H.; Zevenhuizen, J. 1990. Quaternary sediment maps of the Gulf of St. Lawrence. Vol. 1 Report, figures and cruise reports. Vol. 2 Maps and panels. Geological Survey of Canada Open file report; 2700

Kasuya, T. 1986. Distribution and behavior of Baird's beaked whales off the Pacific coast of Japan. The Scientific Reports of the Whales Research Institute 37: 61-83.

Kingsley, M.C.S. and R.R. Reeves. 1998. Aerial surveys of cetaceans in the Gulf of St. Lawrence in 1995 and 1996. Canadian Journal of Zoology 76:1529-1550

Knudsen, F.R., P.S. Enger and O. Sand. 1992. Awareness reactions and avoidance responses to sound in juvenile Atlantic salmon. Journal of Fisheries Biology 40(4): 523-534.

Kosheleva, V. 1992. The impact of air guns used in marine seismic explorations on organisms living in the Barents Sea. Contr. Petro Piscis II '92 Conference F-5, Bergen, 6-8 April, 1992.

Kulka, D., C. Hood and J. Huntington. 2007. Recovery Strategy for Northern Wolffish (*Anarhichas denticulatus*) and Spotted Wolffish (*Anarhichas minor*), and Management Plan for Atlantic Wolffish (*Anarhichas lupus*) in Canada [Proposed]. Fisheries and Oceans Canada: Newfoundland and Labrador Region. St. John's, NL. x + 103 pp.

Kulka, D.W., N.C. Antle, and J.M. Simms. 2003. Spatial analysis of 18 demersal species in relation to petroleum licence areas on the Grand Bank (1980-2000). Canadian Technical Report on Fisheries and Aquatic Sciences 2473. 202 pp.

LaBella, G., C. Froggia, A. Modica, S. Ratti and G. Rivas. 1996. First assessment of effects of air-gun seismic shooting on marine resources in the central Adriatic Sea. Society of Petroleum Engineers, Inc. International Conference on Health, Safety and Environment, New Orleans, Louisiana, U.S.A., 9-12 June 1996.

Lacroix, D.L., R.B. Lanctot, J.A. Reed and T.L. McDonald. 2003. Effect of underwater surveys on molting male Long-tailed Ducks in the Beaufort Sea, Alaska. Canadian Journal of Zoology. 81:1862-1875.

Lamberton, R.D. 1976. Avifaunal Survey of Gros Morne National Park. Parks Canada Contract Report. Report 74-46.

Laviguer, L., and M. O. Hammill. 1993. Distribution and seasonal movements of grey seals, *Halichoerus grypus*, born in the Gulf of St. Lawrence and eastern Nova Scotia shore. *Canadian Field-Naturalist* 107: 329-340.

Lawson, J.W., R. A. Davis, W.J. Richardson and C.I. Malme. 2000. Assessment of Noise Issues Relevant to Key Cetacean species (Northern Bottlenose and Sperm Whales) in the Sable Gully Area of Interest. Prepared for Oceans Act Coordination Office. LGL Report TA2446-2. July 20, 2000.

LeDrew. 1984. Southeastern Newfoundland marine resources: a literature review. Report to Newfoundland Department of Development by LeDrew Environmental Management Ltd., and Oceans Ltd., St. John's, Newfoundland. 413 p.

Lesage, V., C. Barrette, M.C.S. Kingsley and B. Sjare. 1999. The effect of vessel noise on the vocal behaviour of belugas in the St. Lawrence River Estuary, Canada. *Mar. Mamm. Sci.* 15: 65-84.

Lesage, V., Hammill, M. O., and Kovacs, K. M. 2004. Long-distance movements of harbor seals (*Phoca vitulina*) from a seasonally ice-covered area, the St. Lawrence River estuary, Canada. *Canadian Journal of Zoology* 82: 1070-1081.

Lesage, V., J-F. Gosselin, M. Hammill, M. C.S. Kingsley, and J. Lawson. 2007. Ecologically and Biologically Significant Areas (EBSAs) in the Estuary and Gulf of St. Lawrence - A marine mammal perspective. Department of Fisheries and Oceans, Canadian Science Advisory Secretariat, 94 pp

LGL Limited, Canning and Pitt Associates Inc, Ocean Associates and PAL Environmental Limited. 2005. Western Newfoundland and Labrador Offshore Area Strategic Environmental Assessment. LGL Rep. SA8858. Rep. by LGL Limited, St. John's, NL, Oceans Limited, St. John's, NL, Canning & Pitt Associates, Inc., St. John's, NL, and PAL Environmental Services, St. John's, NL, for Canada-Newfoundland and Labrador Offshore Petroleum Board, St. John's, NL. 335 p. + appendices.

Ljungblad, D.K., B. Würsig, S.L. Swartz and J.M. Keene. 1988. Observations on the behavioral responses of bowhead whales (*Balaena mysticetus*) to active geophysical vessels in the Alaskan Beaufort Sea. *Arctic* 41: 183-194.

Lock, A.R., R.G.B Brown and S.H. Gerriets. 1994. Gazetteer of Marine Birds in Atlantic Canada. Canadian Wildlife Service, Ottawa, 137 pp.

Løkkeborg, S. 1991. Effects of geophysical survey on catching success in longline fishing. International Council for the Exploration of the Sea (ICES) CM B:40. 9 pp.

Lokkeborg, S. and A.V. Soldal. 1993. the influences of seismic exploration on cod (*Gadus morhua*) behavior and catch rates. International Council for the Exploration of the Sea (ICES) Marine Science Symposiu 196: 62-67.

MacLaren, 1977. Report on biological literature review of the Labrador Sea region. Report for Imperial Oil Ltd., by MacLaren Atlantic Ltd., St John's, Newfoundland. 109 pp.

Madsen, P.T., B. Mohl, B.K. Nielsen and M. Wahlberg. 2002a. Male sperm whale behavior during exposures to distant seismic survey pulses. Aquatic Mammology 28(3):231-240.

Malakoff, D. 2002. Suit ties whale deaths to research cruise. Science 298(5594): 722-723.

Malme, C.I., B. Würsig, J.E. Bird and P. Tyack. 1988. Observations of feeding gray  
Malme, C.I., P.R. Miles, C.W. Clark, P. Tyack and J.E. Bird. 1984. Investigations of the potential effects of underwater noise from petroleum industry activities on migrating gray whale behavior. Phase II: January 1984 migration. BBN Report 5586. Bolt, Beranek and Newman Report for Minerals Management Service, United States Department of the Interior, Washington, DC.

Malme, C.I., P.R. Miles, P. Tyack, C.W. Clark and J.E. Bird. 1985. Investigation of the potential effects of underwater noise from petroleum industry activities on feeding humpback whale behavior. BBN Report 5851; OCS Study MMS 85-0019. Rep. from BBN Labs Inc., Cambridge, MA, for United States Minerals Management Service, Anchorage, AK.

Mansfield, A.W., and Beck, B. 1977. The grey seal in eastern Canada. Fisheries and Marine Services Technical Report 704.

Mansfield. A. W. 1967b. Distribution of the harbor seal, *Phoca vitulina* Linnaeus, in Canadian Arctic waters. J. Mammal. 48: 249-257

Marquez, R. 1990. FAO Species Catalogue. Vol. 11. Sea turtles of the world. An annotated and illustrated catalogue of sea turtle species known to date. FAO Fisheries Symposium No 125 vol. 11. 81 pp.



Martec Limited. 1984. Report on the Environmental Program Associated with the Blowout at Shell *et al.* Uniacke G-72. Report for Shell Canada Resources Limited, Dartmouth, NS.

McCauley, R.D. 1994. Environmental implications of offshore oil and gas development in Australia-seismic surveys. *In*: J.M. Swan, J.M. Neff and P.C. Young (Eds.), Environmental implications of offshore oil and gas development in Australia. Australian Petroleum Exploration Association and Energy Research Development Corporation, Sydney, AU. pp 19-122.

McCauley, R.D., J. Fewtrell, A.J. Duncan, C. Jenner, M.-N. Jenner, J.D. Penrose, R.I.T. Prince, A. Adhitya, J. Murdoch and K. McCabe. 2000a. Marine seismic surveys: Analysis of airgun signals; and effects of air gun exposure on humpback whales, sea turtles, fishes and squid. Rep. from Centre for Marine Science and Technology, Curtin Univ., Perth, W.A., for Austral. Petrol. Prod. Assoc., Sydney, N.S.W. 188 pp.

McCauley, R.D., J. Fewtrell, A.J. Duncan, M.-N. Jenner, M.-N., C. Jenner, R.I.T. Prince, A. Adhitya, K. McCabe and J. Murdoch. 2000b. Marine seismic surveys - a study of environmental implications. APPEA (Australian Petroleum Producers and Explorers Association) Journal 40:692-708.

McCauley, R.D., J. Fewtrell, A.J. Duncan, M.-N. Jenner, M.-N., C. Jenner, R.I.T. Prince, A. Adhitya, K. McCauley, R.D., J. Fewtrell and A.N. Popper. 2003. High intensity anthropogenic sound damages fish ears. Journal of the Acoustical Society of America 113(1): 638-642.

McCauley, R.D., M.-N. Jenner, C. Jenner, K.A. McCabe and J. Murdoch. 1998. The response of humpback whales (*Megaptera novaeangliae*) to offshore seismic survey noise: preliminary results of observations about a working seismic vessel and experimental exposures. APPEA (Australian Petroleum Producers and Explorers Association) Journal 1998: 692-707.

McDonald, M.A., J.A. Hildebrand and S.C. Webb. 1995. Blue and fin whales observed on a seafloor array in the Northeast Pacific. J Journal of the Acoustical Society of America 98: 712-721

Miller, G.W., V.D. Moulton, R.A. Davis, M. Holst, P. Millman, A. MacGillivray and D. Hannay. 2005. Monitoring seismic effects on marine mammals--southeastern Beaufort Sea, 2001-2002. p. 511-542 *In* : S.L. Armsworthy, P.J. Cranford and K. Lee (eds.), Offshore

oil and gas environmental effects monitoring/Approaches and technologies. Battelle Press, Columbus, Ohio.

Miller, G.W., R.E. Elliott, W.R. Koski, V.D. Moulton and W.J. Richardson. 1999. Whales [1998]. pp. 5- 1 to 5-109. *In*: W.J. Richardson (ed.), Marine mammal and acoustical monitoring of Western Geophysical's open-water seismic program in the Alaskan Beaufort Sea, 1998. LGL Rep. TA2230-3. Rep. from LGL Ltd., King City, Ont., and Greeneridge Sciences Inc., Santa Barbara, CA, for Western Geophysical, Houston, TX, and U.S. National Marine Fisheries Service, Anchorage, AK, and Silver Spring, MD. xx + 390 pp.

MMS (Minerals Management Service). 2004. Geological and Geophysical Exploration for Mineral Resources on the Gulf of Mexico Outer Continental Shelf: Final Programmatic Environmental Assessment. United States Department of the Interior, Gulf of Mexico Outer Continental Shelf Region.

Moein, S.E., J.A. Musick, J.A. Keinath, D.E. Barnard, M.L. Lenhardt, and R. George, 1994. Evaluation of Seismic Sources for Repelling Sea Turtles from Hopper Dredges. Virginia Institute of Marine Science, College of William and Mary, Gloucester Point, VA, final contract report to U.S. Army Engineer Waterways Experiment Station. *In*: Sea Turtle Research Program Summary Report. Prepared by U.S. Army Engineer Waterways Experiment Station, Vicksburg, MS for U.S. Army Engineer Division, South Atlantic, Atlanta, GA and U.S. Naval Submarine Base, Kings Bay, GA, Technical Report CHL-97-31, NTIS ADA332588. 147 pp.

Møhl, B., M. Wahlberg, P.T. Masden, A. Heerfordt and A. Lundt. 2003. The monopulsed nature for sperm whale clicks. *Journal of the Acoustical Society of America* 114:143-155

Montevecchi, W.A. 2006. Influences of artificial light on marine birds. pg 94-113. *In*: Ecological Consequences of Artificial Night Lighting. Rich C and T. Longeore (eds.) Island Press 480 pp.

Moore, P.W.B. and D.A. Pawloski. 1990. Investigations on the control of echolocation pulses in the dolphin (*Tursiops truncatus*). p. 305-316. *In*: J.A. Thomas, and R.A. Kastelein (eds.), Sensory abilities of cetaceans/laboratory and field evidence. Plenum Press, New York. 710 pp.

Myrberg, A.A. 1980. Hearing in damsel fishes: An analysis of signal detection among closely related species. *Journal of Comparative Physiology A*, 140: 135-144.

National Energy Board (NEB), Canada-Newfoundland and Labrador Offshore Petroleum Board (CNLOPB), and Canada-Nova Scotia Offshore Petroleum Board (CNSOPB). 2002. Offshore Waste Treatment Guidelines. 21 pp. Available online: <http://www.cnlopb.nl.ca/publicat/guidelin/owtgl/eng/owtg0208.pdf>

Newfoundland Labrador Heritage Project 1999. Online: <http://www.heritage.nf.ca/home.html>

NMFS. 2000. Taking and importing marine mammals: Taking marine mammals incidental to naval activities/proposed rule. Federal Registry 65(239 12 December): 77546-77553.

Parsons, T.R., Takahashi, M., and Hargrove, B., 1984. Biological Oceanographic Processes (3rd ed.). Pergamon Press, New York.

Parvulescu, A. 1964. Problems of propagation and processing. In: Tavolga, W.N. (ed) Marine bioacoustics. Pergamon Press, Oxford. pp 87-100.

Payne, J.F., C.A. Andrews, L.L. Fancy, A.L. Cook and J.R. Christian. 2007. Pilot study on the effects of seismic air gun noise on lobster (*Homarus americanus*). Canadian Technical Report of Fisheries and Aquatic Sciences 2712. 46 pp.

Pearson, W., J. Skalski, S. Sulkin and C. Malme. 1994. Effects of seismic energy releases on the survival and development of zoeal larvae of Dungeness crab (*Cancer magister*). Marine Environmental Research 38: 93-113.

Pearson, W.H., J.R. Skalski and C.I. Malme. 1992. Effects of sounds from a geophysical survey device on behavior of captive rockfish (*Sebastes spp*). Canadian Journal of Fisheries and Aquatic Sciences 49: 1343-1356.

Popper, A.N., M. Salmon and K.W. Horch. 2001. Acoustic detection and communication by decapod crustaceans. Journal of Comparative Physiology 187: 83-89.

Protasov, V.R. 1966. Bioacoustics of fishes. Springfield, Vermont. NTIS, 214 pp.

Rail, J.-F., and G. Chapdelaine. 2002. Quinzième inventaire des oiseaux marins dans les refuges de la Côte Nord: techniques et résultats détaillés. Séries de rapports techniques no. 392. Service canadien de la faune, région du Québec, Environment Canada, Sainte-Foy, QC.

Reeves, R.R. and M.W. Brown. 1994. Marine Mammals and the Canadian Patrol Frigate Shock Trials: A Literature Review and Recommendations for Mitigating the Impacts. Report to National Defence Headquarters, Ottawa, ON. 105 pp.

Reid, R.N., Cargnelli, L.M., Griesbach, S.J., Packer, D.B., Johnson, D.L., Zetlin, C.A., Morse, W.W., Berrien, P.L. 1999. Essential fish habitat source document: Atlantic herring, *Clupea harengus*, life history and habitat characteristics. NOAA Technical Memorandum NMFS-NE-126. 48 pp.

Richardson, W. J., C. R. Greene, Jr. C.I. Malme and D. H. Thomson. 1995. Marine mammals and noise. Academic Press, San Diego. 576 pp.

Richardson, W.J. and C.I. Malme. 1993. Man-made noise and behavioral responses. pp. 631-700 *In*: J.J. Burns, J.J. Montague and C.J. Cowles (eds.), The bowhead whale. Special Publication 2, Society for Marine Mammalogy, Lawrence, Kansas. 787 pp.

Richardson, W.J., B.W. Würsig and C.R. Greene Jr. 1986. Reactions of bowhead whales, *Balaena mysticetus*, to seismic exploration in the Canadian Beaufort Sea. Journal of the Acoustical Society of America. 79: 1117- 1128.

Richardson, W.J., B.W. Würsig and C.R. Greene Jr. 1986. Reactions of bowhead whales, *Balaena mysticetus*, to seismic exploration in the Canadian Beaufort Sea. Journal of the Acoustical Society of America 79: 1117- 1128.

Richardson, W.J., C.R. Greene, Jr., C.I. Malme and D.H. Thomson. 1995. Marine mammals and noise. Academic Press, San Diego. 576 pp.

Ridgway, S.H., E. G. Wever, J.G. McCormick, J. Palin, and J.H. Anderson. 1969. Hearing in the Giant Sea Turtle, *Chelonia mydas*. Proceedings of the National Academy of Sciences of the United States of America: 64 (3) 884-890

Riley, D.C. 1984. Post-mortem report, Uniacke well blowout incident. Fisheries and Oceans Canada.

Robertson, G. J., and R. I. Goudie. 1999 . Harlequin Duck (*Histrionicus histrionicus*). *In*: A. Poole and F. Gill, (eds). The Birds of North America, No. 466. The Birds of North America Inc., Philadelphia, Pennsylvania.

Robillard, A., Lesage, V., and Hammill, M. O. 2005. Distribution and abundance of harbour seals (*Phoca vitulina concolor*) and grey seals (*Halichoerus grypus*) in the Estuary

and Gulf of St. Lawrence, 1994–2001. Canadian Technical Report of Fisheries and Aquatic Sciences 2613: 1-152.

Romanenko, E.V. and V.Ya. Kitain. 1992. The functioning of the echolocation system of *Tursiops truncatus* during noise masking. pp. 415-419. In: J.A. Thomas, R.A. Kastelein and A.Ya. Supin (eds.), Marine Mammal Sensory Systems. Plenum, New York. 773 pp.

Royal Society of Canada. 2004. Report of the Expert Panel on Science Issues Related to Oil and Gas Activities, Offshore British Columbia. Prepared at the request of Natural Resources Canada, Ottawa, Ontario

Runge, J.A. and Y. de Lafontaine. 1996. Characterization of the pelagic ecosystem in surface waters of the northern Gulf of St. Lawrence in early summer: the larval redfish-*Calanus*-microplankton interaction. Fisheries Oceanography 5(1): 21-37.

Saetre, R. and E. Ona. 1996. Seismike undersøkelser og på fiskeegg og -larver en vurdering av mulige effekter på bestandsniva. [Seismic investigations and damages on fish eggs and larvae; an evaluation of possible effects on stock level] Fisken og Havet 1996:1-17, 1-8. (in Norwegian, with an English summary - full translation not published).

Sandford, B.V., 1993a: St. Lawrence Platform – Introduction. Chapter 10. In Sedimentary Cover of the Craton in Canada, D.F. Stott and J.D. Aitken (eds.); Geological Survey of Canada, Geology of Canada, no. 5, pp. 709-722

Sandford, B.V., 1993b: St. Lawrence Platform – Geology; Chapter 11 In Sedimentary Cover of the Craton in Canada, D.F. Stott and J.D. Aitken (eds.); Geological Survey of Canada, Geology of Canada, no. 5, pp. 723-786

Santulli, A., C. Messina, L. Ceffa, A. Curatolo, G. Rivas, G. Fabi and V. Damelio. 1999. Biochemical responses of European sea bass (*Dicentrarchus labrax*) to the stress induced by offshore experimental seismic prospecting. Marine Pollution Bulletin 38:1105-1114.

Saunders, J. and R. Dooling. 1974. Noise-Induced Threshold Shift in the Parakeet (*Melopsittacus undulatus*). Proceedings of the National Academy of Sciences of the United States of America 71(5):1962-1965

Schwartz, A.L. and G.L. Greer. 1984. Responses of Pacific herring, *Clupea harengus pallasii* to some under water sounds. Canadian Journal of Fisheries and Aquatic Sciences 41:1183-1192.

Scott, W.B. and M.G. Scott. 1988. Atlantic Fishes of Canada. University of Toronto Press. Toronto, ON. Canadian Bulletin of Fisheries and Aquatic Sciences 219, 731 pp.

Sears, R. and J. Calambokidis. 2002. Update COSEWIC status report on the Blue Whale *Balaenoptera musculus* in Canada, in COSEWIC assessment and update status report on the Blue Whale *Balaenoptera musculus* in Canada. Committee on the Status of Endangered Wildlife in Canada. Ottawa. 32 pp.

Sergeant, D.E. 1976. History and present status of populations of harp and hooded seals. Biological Conservation 10:95-118.

Sergeant, D.E. 1982b. Some biological correlates of environmental conditions around Newfoundland during 1970-1979; harp seals, blue whales, and fulmar petrels. NAFO Scientific Council Studies 5:107-110.

Sergeant, D.E. 1991. Harp seals, man and ice. Canadian Special Publications of Fisheries and Aquatic Sciences 114, 153 pp.

Sinclair, I.K.. 1990. A Review of the Upper Precambrian and Lower Paleozoic Geology of Western Newfoundland and the Hydrocarbon Potential of the Adjacent Offshore Area of the Gulf of St. Lawrence. CNLOPB Report GLCNOPB-90-1

Skalski, J.R., W.H. Pearson and C.I. Malme. 1992. Effects of sounds from a geophysical survey device on catch-per-unit-effort in a hook-and-line fishery for rockfish (*Sebastes spp*). Canadian Journal of Fisheries and Aquatic Sciences 49(7):1357-1365.

Smith, M.E., A.S. Kane, and A.N. Popper. 2004. Noise-induced stress response and hearing loss in goldfish (*Carassius auratus*). Journal of Experimental Biology 207:427-435.

South, G.R., A. Whitlatch and R. Hooper. 1979. Biological bibliography of the Labrador Sea and coastal Labrador. Report to Total Eastern Exploration Ltd., St John's, Newfoundland. 328 pp.

Stafford, K.M., C.G. Fox, and D.S. Clark. 1998. Long-range acoustic detection and localization of blue whale calls in the northeastern Pacific Ocean. Journal of the Acoustical Society of America 104:3616-3625.

Stemp, R. 1985. Observations on the effects of seismic exploration on seabirds. Pp. 217-233 In: G.D. Greene, F.R. Engelhardt and R.J. Peterson (eds.), Proceedings of workshop

on effects of explosives use in the marine environment. Canadian Oil and Gas Administration, Environmental Protection Branch, Technical Report 5. Ottawa.

Stobo, W. T., Beck, B., and Horne, J. K. 1990. Seasonal movements of grey seals (*Halichoerus grypus*) in the Northwest Atlantic. Canadian Bulletin of Fisheries and Aquatic Sciences 222: 199-213.

Stone, C.J. 2003. The effects of seismic activity on marine mammals in UK waters 1998-2000. JNCC Report 323. Joint Nature Conservancy, Aberdeen, Scotland. 43 pp.

Stout, H.B. 1993. Overview of oiled bird rehabilitation. The effects of oil on wildlife. p A38-A39. Third international conference.

Swail, V. R., EA Seccacci, and A.T. Cox. 1999. The AES40 North Atlantic wind and wave reanalysis: Validation and climate assessment. Preprints, 6th Int'l Workshop on Wave Hindcasting and Forecasting, Nov. 6-10, 2000, Monterey, Ca, USA p. 1-15.

Swail, V.R. and A. T. Cox, 2000: On the use of NCEP/NCAR reanalysis surface marine wind fields for a long term North Atlantic wave hindcast. Journal of Atmospheric and Oceanographic Technology 17: 532-545.

Templeman, W. 1948. The life history of the capelin (*Mallotus villosus* O. F. Mu" ller) in Newfoundland waters. Research Bulletin of the Newfoundland Government Laboratory 17, 151 pp.

Terhune, J.M. 1999. Pitch separation as a possible jamming-avoidance mechanism in underwater calls of bearded seals (*Erignathus barbatus*). Canadian Journal of Zoology 77: 1025-1034.

Thomas, J.A. and C.W. Turl. 1990. Echolocation characteristics and range detection threshold of a false killer whale (*Pseudorca crassidens*). pp. 321-334. In: J.A. Thomas and, and R.A. Kastelein (eds.), Sensory Abilities of Cetaceans/Laboratory and Field Evidence. Plenum Press, New York. 710 pp.

Thomas, P.W., and M. Robert. 2001. The updated status report of the Eastern North American Harlequin Duck (*Histrionicus histrionicus*). Committee On the Status of Endangered Wildlife In Canada (COSEWIC), Ottawa, Ontario

Thompson, R.J. and D.A. Aggett. 1981. Biological and oceanographic descriptions of the Labrador Sea region. Report to Canadian National Parks Service, Ottawa, Ontario.130 p.

Thomsen, B. 2002. An experiment on how seismic shooting affects caged fish. Faroese Fisheries Laboratory, University of Aberdeen, Scotland.

Thomson, D.H., R.A. Davis, R. Belore, E. Gonzalez, J. Christian, V.D. Moulton and R.E. Harris. 2000. Environmental Assessment of Exploration Drilling off Nova Scotia. Prepared for Canada-Nova Scotia Offshore Petroleum Board and Mobil Oil Canada Properties, Shell Canada Ltd., Imperial Oil Resources Ltd., Gulf Canada Ltd., Chevron Canada Resources, PanCanadian Petroleum Ltd., Marathon Canada Ltd., Murphy Oil Company Ltd., and Norsk Hydro Canada Oil and Gas Inc.

Tibbo, S.N. 1956. Populations of herring (*Clupea harengus* L.) in Newfoundland waters. Journal of the Fisheries Research Board of Canada 13: 449-466.

Tibbo, S.N., Scarratt, D.J., McMullon, P.W.G. 1963. An investigation of herring (*Clupea harengus* L.) spawning using free-diving techniques. of the Fisheries Research Board of Canada 20: 1067-1079.

Turnpenny, A.W.H. and J.R. Nedwell. 1994. The effects on marine fish, diving mammals and birds of underwater sound generated by seismic surveys. Report by Fawley Aquatic Research Laboratories Ltd. for United Kingdom Offshore Operators Association Limited. London. 40 pp.

Urick, R.J. 1983. Principles of Underwater Sound, McGraw-Hill Publishing Company.

Wardle, C.S., T.J. Carter, G.G. Urquhart, A.D.F. Johnstone, A.M. Ziolkowski, G. Hampson and D. Mackie. 2001. Effects of seismic air guns on marine fish. Continental Shelf Research 21(8-10): 1005-1027.

Weir, R.D. 1976. Annotated bibliography of bird kills at man-made obstacles: a review of the state of the art and solutions. Dept. of Fisheries and Environment. Environmental Management Services. Cdn Wildlife Service, Ontario, Ottawa.

Wenz, G.M. 1962. Acoustic ambient noise in the ocean: spectra and sources. Journal of the Acoustical Society of America 34:1936-1956.

White, L. and F. Johns. 1997. Marine environmental assessment of the Estuary and Gulf of St. Lawrence. Fisheries and Oceans Canada, Dartmouth, NS and Mont-Joli, QC



Wiese, F.K. 1999. Beached bird surveys in SE Newfoundland 1984-1997. Canadian Wildlife Service (CWS) Contract Report KE 209-8-043. 80 pp.

Williams, H., 1995b: Temporal and spatial divisions; Chapter 2 in *Geology of the Appalachian- Caledonian Orogen in Canada and Greenland*, (ed.) H. Williams; Geological Survey of Canada, *Geology of Canada*, no. 6, p. 21-44 .

Williams, H., 1995c: Introduction (Humber Zone); Chapter 3 in *Geology of the Appalachian-Caledonian in Canada and Greenland*, (ed.) H. Williams; Geological Survey of Canada, *Geology of Canada*, no. 6, p. 47-49

Williams, U. and J. Chardine. nd. *The Leach's Storm Petrel: General Information and Handling Instructions*.

Witzell, W.N. 1999. Distribution and relative abundance of sea turtles caught incidentally by the US pelagic longline fleet in the western North Atlantic Ocean. 1992-1995. *Fisheries Bulletin* 97:200-211.

Woodworth-Lynas, C.M.T. 1992. *The geology of ice scour*. Unpublished Ph.D. thesis, University of Wales, 269 pp.

Worm, B. And R. A. Myers. 2003. Meta-analysis of cod-shrimp interactions reveals top-down control in oceanic food webs. *Ecology*: 84(1):162-173

Würsig, B., S.K. Lynn, T.A. Jefferson and K.D. Mullin. 1998. Behaviour of cetaceans in the northern Gulf of Mexico relative to survey ships and aircraft. *Aquatic Mammology* 24(1):41-50.

Yvelin, J-F., A. Fréchet and J-C, Brethes. 2005. Migratory routes and stock structure of cod from the northern Gulf of St. Lawrence. Canadian Science Advisory Secretariat Research Document 2005/055. 50pp.

APPENDIX A

THE LEACH'S STORM-PETREL: GENERAL INFORMATION  
AND HANDLING INSTRUCTIONS

**The Leach's Storm-Petrel:  
General information and handling instructions**

Urban Williams (Petro-Canada)  
&  
John Chardine (Canadian Wildlife Service)

The Grand Banks is an area that is frequented by large numbers of seabirds, representing a variety of species. Large populations are found in this area in both summer and winter, and come from the Arctic, northern Europe, and the south Atlantic, as well as from colonies along the Newfoundland Coast. One of the species found in the area of the Terra Nova Field is the Leach's Storm-Petrel (*Oceanodroma leucorhoa*).

**The Bird:**

Leach's Storm-Petrels are small seabirds, not much bigger than a Robin. They have relatively long wings and are excellent fliers. Leach's Storm-Petrels are dark brown in colour and show a conspicuous white patch at the base of the tail. In the hand, you can easily notice a small tube at the top of their bill, and you will also notice that the birds have a peculiar, not unpleasant smell (although some Newfoundlanders call these birds "Stink Birds"). Storm-Petrels are easy prey for gulls and other predators, and so to protect themselves from predation, Leach's Storm-Petrels are only active at night when on land at the breeding colonies.



Photo : Gilles Chapdelaine

**Nesting Habitat:**

Leach's Storm-Petrels are distributed widely in the northern hemisphere, however, their major centres of distribution are Alaska and Newfoundland. The bird breeds on offshore islands, often in colonies numbering tens or hundreds of thousands of pairs, even millions at one colony in Newfoundland. The nest is a chamber, sometimes lined with some grass, located at the end of a narrow tunnel dug in the topsoil.. Depending on the colony, burrows may be under conifer or raspberry thickets or open grassland.

**Reproduction:**

In Newfoundland, Leach's Storm-Petrels lay their single egg in May and June. The egg is incubated by both parents alternately, sometimes for stretches exceeding 48 hours. The egg is incubated for 41-42 days, which is a long time for such a small egg. The peak hatching period is in the last half of July. The young petrel remains in the tunnel for about 63-70 days. Once breeding is over in late-August or early September, the birds disperse from the colonies and migrate to their wintering grounds in the Atlantic. September is the most important period for migration of Storm-Petrels to the offshore areas such as near the Terra Nova field.

**Populations:**

Canada alone supports more than 5 million pairs of Leach's Storm-Petrels. Most of them are found in Newfoundland. The Leach's Storm-Petrel colony located on Baccalieu Island is the largest known colony of this species.

Nesting sites for Leach's Storm-Petrels are found along the southeast coast of Newfoundland. These are - i) Witless Bay Islands (780,00 nesting pairs), ii) Iron Island (10,000 nesting pairs), iii) Corbin Island (100,000 nesting pairs), iv) Middle Lawn Island (26,000 nesting pairs), v) Baccalieu Island (3,336,000 nesting pairs), vi) Green Island (72,000 nesting pairs), and vii) St. Pierre Grand Columbier (100,000 nesting pairs).

**Feeding Habits:**

Leach's Storm-Petrels feed at the sea surface, seizing prey in flight. Prey usually consists of myctophid fish and amphipods. The chick is fed planktonic crustaceans, drops of stomach oil from the adult bird, and small fish taken far out at sea. Storm-Petrels feed far out from the colony and it would be reasonable to assume that birds nesting in eastern Newfoundland can be found feeding around the Terra Nova site.

**The Problem:**

As identified in the C-NOPB Decision 97-02, seabirds such as Leach's Storm-Petrels are attracted to lights on offshore platforms and vessels. Experience has shown that Storm-Petrels may be confused by lights from ships and oil rigs, particularly on foggy nights, and will crash into lighted areas such as decks and portholes. Fortunately, this type of accident does not often result in mortality, however, once on deck the bird will sometimes seek a dark corner in which to hide, and can become fouled with oil or other contaminants on deck.

### **Period of Concern:**

Leach's Storm-Petrels are in the Terra Nova area from about May until October and birds could be attracted to lights at any time throughout this period. The period of greatest risk of attraction to lights on vessels appears to be at the end of the breeding season when adults and newly fledged chicks are dispersing from the colonies and migrating to their offshore wintering grounds. September is the most important period for migration of storm-petrels to the offshore areas. Past experience suggests that any foggy night in September could be problematic and may result in hundreds or even thousands of birds colliding with the vessel.

### **The Mitigation:**

On nights when storm-petrels are colliding with the vessel, the following steps should be taken to ensure that as many birds as possible are safely returned to their natural habitat.

- All decks of the vessel should be patrolled as often as is needed to ensure that birds are picked up and boxed (see below) as soon as possible after they have collided with the vessel. After collision, birds will often "freeze" below lights on deck or seek dark areas underneath machinery and the like.
- Birds should be collected by hand and gently placed in small cardboard boxes. Care should be taken not to overcrowd the birds and a maximum of 10-15 birds should be placed in each box, depending upon its size. The birds are very easy to pick up as they are poor walkers and will not fly up off the deck so long as the area is well-lit. They will make a squealing sound as they are picked up- this is of no concern and is a natural reaction to be handled (the birds probably think they have been captured to be eaten!).
- When the birds are placed in the box the cover should be put in place and the birds left to recover in a dark, cool, quiet place for about 5-10 minutes. The birds initially will be quite active in the box but will soon settle down.
- Following the recovery period, the box containing the birds should be brought to the bow of the boat or to some other area of the vessel that has minimal (if any) lighting. The cover should be opened and each bird individually removed by hand. The release is usually accomplished by letting the bird drop over the side of the vessel. There is no need to throw the bird up in the air at release time. If the birds are released at a well-lit part of the vessel they usually fly back towards the vessel and collide again.
- If any of the birds are wet when they are captured (i.e. they drop into water on the deck) then they should be placed in a cardboard box and let dry. Once the bird is dry it can be released as per the previous instruction. Also, temporarily injured birds should be left for longer to recover in the cardboard box before release.
- Any birds contaminated with oil should be kept in a separate box and not mixed with clean birds. Contact Canadian Wildlife Service at (709) 772-5585 for instructions on how to deal with contaminated birds.
- In the event that some birds are captured near dawn and are not fully recovered before daylight, they should be kept until the next night for release. Storm-Petrels should not be released in

daylight as at this time they are very vulnerable to predation by gulls. Birds should be kept in the cardboard box in a cool, quiet place for the day, and do not need to be fed.

- Someone should be given the responsibility of maintaining a tally of birds that have been captured and released, and those that were found dead on deck. These notes should be kept with other information about the conditions on the night of the incident (moonlight, fog, weather), date, time, etc). **THIS IS A VERY IMPORTANT PART OF THE EXERCISE AS IT IS THE ONLY WAY WE CAN LEARN MORE ABOUT THESE EVENTS.**

### **Handling Instructions:**

- Leach's Storm-Petrels are small, gentle birds and should be handled with care at all times.
- It is recommended that the person handling the birds should wear thin rubber gloves or clean, cotton work gloves. The purpose of the gloves is to protect both the Storm-Petrel and the worker.
- As mentioned Storm-Petrel's have a strong odor that will stick to the handler's hands. Washing with soap and water will remove most of the smell.
- Handling Leach's Storm-Petrels does not pose a health hazard to the worker, however some birds may have parasites on their feathers, such as feather lice. These parasites do not present any risk to humans, however, as a precaution we recommend wearing cotton work gloves or thin rubber gloves while handling birds and washing of hands afterwards.

### **Wilson's Storm Petrels:**

A relative of the Leach's Storm-Petrel is the Wilson's Storm-Petrel. They breed in the south Atlantic and Antarctica and migrate north in our spring to spend the summer in Newfoundland waters. This species is very numerous on the Grand Banks in the summer, and shares the same nocturnal habits as the Leach's Storm-Petrel. Thus it is possible that Wilson's Storm-Petrels may also be attracted to the lights of a vessel at night. The two species are very similar and should be handled in the same way as described above for our Leach's Storm-Petrel.

### **Permits:**

A permit to handle storm-petrels issued by the Canadian Wildlife Service will be held on board the vessel to cover personnel involved in bird collision incidents.

APPENDIX B

REPORT OF MIGRATORY BIRDS SALVAGED





--	--	--	--	--	--

March 2003

# Canadian Wildlife Service – Permit Application

## Salvage of Live Seabirds for Release

Name	Tel:
e-mail address	Fax:
Organization	
Address	

### Project Title

--

### Project Description

Purpose of Project :	
Project Status: <input type="checkbox"/> new <input type="checkbox"/> ongoing	
Project duration (years) _____	
Summary Description:	
Area of Activities:	Date of Activities:
Species expected to be salvaged for release:	
Methods or protocol followed for handling and release:	

Proposed disposition of dead birds:

Other Participants (nominees) -

Signature of Applicant:

Date:

Please attach:

1. Two referrals/testimonials of support for the project (for **new proposals only**)

Send completed form to:

e-mail address: [donna.johnson@ec.gc.ca](mailto:donna.johnson@ec.gc.ca)

mailing address: Canadian Wildlife Service/Service canadien de la faune  
Environment Canada/Environnement Canada  
17 Waterfowl Lane, P.O. Box 6227  
Sackville, N.B. E4L 1G6

Phone: (506) 364-5044

Fax: (506) 364-5062

APPENDIX C

STANDARDIZED PROTOCOLS FOR PELAGIC SEABIRD SURVEYS  
FROM MOVING PLATFORMS

**STANDARDIZED PROTOCOLS FOR PELAGIC SEABIRD SURVEYS  
FROM MOVING AND STATIONARY PLATFORMS**  
(Experienced Observers)

**VERSION 1.2 – JULY 2006**

Canadian Wildlife Service  
Environment Canada – Atlantic Region  
Dartmouth, Nova Scotia

*Version 1.2*

6 July 2006



Environment Canada  
Atlantic Region

Environnement Canada  
Région de l'Atlantique

## TABLE OF CONTENTS

1. INTRODUCTION.....	1
2. SEABIRD SURVEY PROTOCOL FOR MOVING PLATFORMS.....	3
2.1 General methodology.....	3
2.2 Recording information related to each observation period.....	5
3. SEABIRD SURVEY PROTOCOL FOR STATIONARY PLATFORMS.....	5
3.1 General methodology.....	5
3.2 Recording information related to each scan.....	6
4. LIST OF CONSULTED REFERENCES.....	7

## LIST OF APPENDICES

Appendix I. Example of survey using a 90° scan, covering a 300m transect from a moving platform.....	8
Appendix II. Example of survey using a 180° scan, covering a semi-circle of 300m radius from a stationary platform. ....	9
Appendix III. Estimating a 300m distance at sea using a slide calliper (formula derived by J. Chardine, based on Heinemann 1981).....	10
Appendix IV. Intervals at which instantaneous or “snapshot” counts of flying birds should be conducted within a ten-minute observation period, within a 300m transect from a moving platform.....	11
Appendix V. Notes on completing Observation Period Information for a moving platform.....	12
Appendix VI. Notes on completing Scan Information from a stationary platform.....	14
Appendix VII. Notes on completing Bird Information.....	16
Appendix VIII. List of species code for seabirds seen within the Atlantic Waters of Canada's Exclusive Economic Zone (EEZ).....	17
Appendix IX. Codes for sea state and Beaufort wind force.....	19
Appendix X. Codes for associations and behaviours of seabirds recorded during surveys at sea.....	20
Appendix XI. Example of a 10-min survey from a moving platform.....	21
XI.1 <i>Scenario</i> .....	21
XI.2 <i>Scenario Figure</i> .....	23
XI.3 <i>Datasheet</i> .....	24
Appendix XII. Example of completed record sheet for a stationary platform.....	25
Appendix XIII. Check-list of materials required while conducting seabird surveys.....	26
Appendix XIV. Blank record sheets for moving and stationary platforms.....	27

## 1. INTRODUCTION

**Protocol objectives.** The main objective of this protocol is to ensure that observers conducting surveys at sea are recording data in a consistent, unbiased fashion that permit subsequent conversion into seabird densities. Such data are important for the monitoring of seabird abundance and species composition over space and time, which in turn help support future environmental assessments, and assess potential impacts of the hydrocarbon industry, as well as chronic ship-based oil pollution. This protocol is tailored after current methods used elsewhere in the world, making these data comparable to datasets of other geographic areas. Two protocols are presented here for surveys conducted from two types of observation platforms: moving (e.g., fishing fleet, seismic vessel) and stationary (e.g., oil production rig, supply vessel on stand-by).

**Observer requirements.** These survey protocols should be used by observers with some level of experience conducting pelagic seabird surveys to ensure that appropriate information is collected in a consistent fashion for maximum value. Observers should have adequate training in seabird identification, and in methods for conducting and recording observations in a standardized way. Observers should also be dedicated to conducting surveys at sea while on the platform, and should not have other potentially conflicting duties. Less experienced observers, and those tasked with multiple duties who might have limited time to conduct seabird observations, are encouraged to follow the modified version of this protocol that requires less experience and focussed attention (*Standardized Protocols for Seabird Surveys from Moving and Stationary Platforms for the Hydrocarbon Industry*, CWS publication).

## 2. SEABIRD SURVEY PROTOCOL FROM MOVING PLATFORMS

### 2.1. General methodology

**Observer position.** Whenever possible, conduct observations at a high location near the front of the platform. A high position facing the bow of the vessel (e.g., on the bridge) increases the detection rates of birds, especially species that dive to escape, such as auks. If weather permits, observations can be conducted from a position outdoors.

**The transect method.** Conduct surveys while looking forward from the moving platform, scanning at a 90° angle from either the port or starboard side, limiting observations to a transect band 300m wide from the side of the platform (Appendix I). This band is referred to as the area “in transect”.

**Estimating transect width.** Estimate the width of the 300m transect prior to beginning observations. This can be done by practicing with a buoy towed on a 300m rope behind a moving platform, using a range finder on a stationary object (e.g., a buoy) while the platform is docked, or using a slide calliper (Appendix III).

**Ten-minute periods.** A survey consists of a series of ten-minute observation periods, which are exclusively dedicated to detecting birds at sea. Only take breaks at the end of a ten-minute period. Conduct as many consecutive ten-minute observation periods as possible, regardless if birds are present or not, and try to ensure consistent coverage throughout the day.

**Continuous counts of birds.** Scan the transect continuously by eye, to count and identify birds present in air or on water. Use binoculars to confirm the species identification, and other details, such as age, moult, carrying fish, etc. Scan ahead regularly (e.g., every minute) to detect birds that may dive as the platform approaches. If large concentrations of birds in the transect fly off as the moving platform approaches, use binoculars to help count individuals, and record these as being on water.

**Birds on water.** Continuously record all birds observed on the sea surface throughout the ten-minute period, and estimate their distance perpendicular from the mid-line of the platform (see Appendix VII for distance categories). Leach's Storm-petrels observed tapping the surface of the water with feet and bill, and Northern Gannets diving into the sea, should be recorded as being on water with the behaviour code that indicates feeding (Appendix X).

**Birds in flight.** Flying birds are not recorded continuously throughout the 10-minute period, as this would overestimate bird density. Instead, record flying birds using instantaneous counts, or "snapshots", at regular intervals throughout the observation period. The number of snapshots conducted will depend on the speed of the platform (see Appendix IV for time intervals between snapshots). For example, if the platform is moving at a speed of 10 knots, snapshots will occur every minute for the 10-minute observation period. During each snapshot, record flying birds as "in transect" only if they are above the 300m strip transect AND observed when the snapshot is being done. If possible, estimate the distance of the flying bird *when it was first observed* (see Appendix VII for distance categories). Record all other flying birds that are seen outside of the transect or between snapshot intervals as "not in transect", and estimate their distance at the time they were first observed. See Appendix XI for an example of how to record data for birds on water and in flight.

**Minimum requirements.** Only conduct observations when the platform is travelling at a minimum speed of 4 knots (7.4 km/h) and a maximum of 19 knots (35.2 km/h).

**Poor visibility.** When a scheduled observation cannot be conducted because visibility is poor due to rain or fog (i.e., when the entire width of the 300m transect is not visible), fill in the Observation Period Information, and write in the notes section why the observation was not conducted.

**Null observation periods.** Record "No birds observed" when no birds were detected during a ten-minute period, as this type of information is also important.



## 2.2. Recording information related to each observation period

**Observation period information.** It is important to fill in all the fields under the heading “Observation period information” of the data sheet at the beginning of every ten-minute observation period. **See Appendix V for detailed notes on filling in each field.**

**Bird information.** Use appropriate codes to record the following information (in this order of priority) for all birds observed during the period, whether within or outside the transect:

- 1) Species (see Appendix VIII for list of species code)
- 2) Number of individuals
- 3) Flying (*F*) or on the water (*W*)
- 4) In transect? *Y* or *N*
- 5) Distance from vessel using categories (see Appendix VII for distance codes)
- 6) Association (see Appendix X for association codes)
- 7) Behaviour (see Appendix X for behaviour codes)
- 8) Compass direction (*N*, *NE*, *E*, *SE*, *S*, *SW*, *W*, or *NW*) in which birds in flight are heading, if they are not associated with platform.
- 8) Age (*J*, *I*, or *A*)
- 9) Plumage of adults (*B*, *NB*, and/or *M*)
- 10) Sex (*M* or *F*)

**See Appendix VII for detailed notes on filling in each field.**

**Grouping observations.** Record groups of birds in the same data row, if they behave as a group and have the same morphological and behavioural characteristics (e.g., all adults in breeding plumage flying in the same direction; see example in Appendix XI). Record other individuals from the group that have different characteristics (e.g., juveniles) in the next row, and associate this record with the previous one by drawing a line that links the two rows (see example in Appendix XI.3f).

## 3. SEABIRD SURVEY PROTOCOL FOR STATIONARY PLATFORMS

### 3.1. General methodology

**The scan method.** Observations from stationary platforms are conducted using instantaneous counts, or “snapshots” of birds within an area that is scanned at regular intervals throughout the day. The length of the survey will depend on the number of birds present at the time of the scan, and may last only a few seconds if no birds are present.

**Observer position.** Whenever possible, conduct scans from a position outdoors, as close to the edge of the platform as permitted. A position near the edge will increase the detection rates of birds, especially for individuals that use the waters at the base of the platform. Conduct scans at the same location each time, and ensure that other observers use the same location.

**Delineated survey area.** Conduct surveys by scanning at a 180° angle, limiting observations to a semi-circle around the observer, with a radius of 300m from the edge of the platform (see Appendix II). Sweep the area only once per scan, from one side to the other, and systematically record all birds on water and in flight within the area at that time.

**Estimating “in observation” area.** Estimate the 300m distance prior to beginning observations. You can base your estimate on the known width of the platform or fixed structure, or by using a slide calliper (see Appendix III).

**Frequency of scans.** Scan the same area once every 2 hours from morning to evening, regardless if birds are present or not.

**Snapshot counts of birds.** Scan the area once per survey. If the stationary platform is high (e.g., an oil production platform), use binoculars to count and identify birds present in the air or on the water. Use a telescope to confirm species identification and other details, such as moult, age, carrying fish, etc. If the stationary platform is relatively low (e.g., a supply vessel on stand-by), scan the area by eye to count and identify birds, and confirm details using binoculars.

**Birds on water and in flight.** Estimate the distance that observed birds are from the base of the platform (see Appendix VII for distance categories).

**Poor visibility.** When a scheduled scan cannot be conducted because visibility is poor due to rain or fog (i.e., when the entire width of the 300m semi-circle is not visible), fill in the Observation Period Information, and write in the notes why the scan was not conducted.

**Null observation periods.** Record “No birds observed” when no birds were detected during a scan, as this type of information is also important.

### **3.2. Recording information related to each scan**

**Scan information.** It is important to fill in all the fields under the heading “Scan Information” of the data sheet at the beginning of each scan. **See Appendix VI for detailed notes on completing each field.**

**Bird information.** Use appropriate codes to record the following information (in this order of priority) for all birds observed during the period, whether within or outside the semi-circle:

- 1) Species (see Appendix VIII for list of species code)
- 2) Number of individuals
- 3) Flying (*F*) or on the water (*W*)
- 4) In semi-circle? *Y* or *N*
- 5) Distance from platform using categories (see Appendix VII for distance categories)
- 6) Association (see Appendix X for association codes)
- 7) Behaviour (see Appendix X for behaviour codes)

- 8) Compass direction (*N, NE, E, SE, S, SW, W, or NW*) in which birds in flight are heading, if not associated with platform.
- 8) Age (*J, I, or A*)
- 9) Plumage of adults (*B, NB, and/or M*)
- 10) Sex (*M or F*)

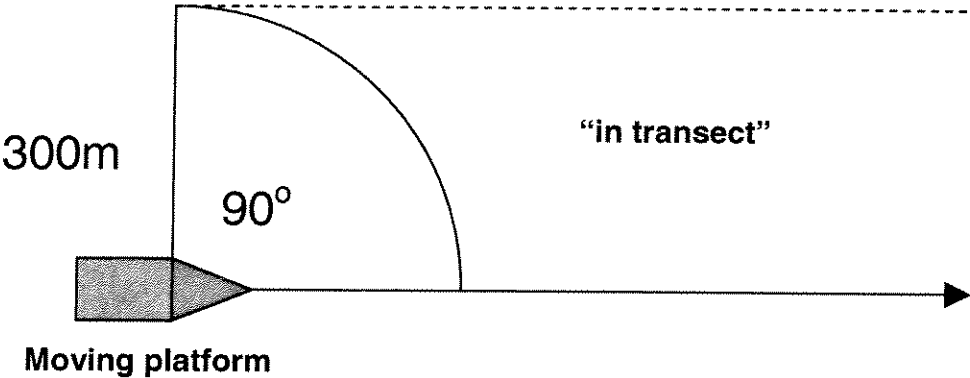
See Appendix VII for detailed notes on completing each field.

**Grouping observations.** Record groups of birds in the same data row if they behave as a group and have the same morphological and behavioural characteristics (e.g., all adults in breeding plumage flying in the same direction; see example in Appendix XII). Record other individuals from the group that have different characteristics (e.g., juveniles) in the next row, and associate this record with the previous one by drawing a line that links the two rows (see example in Appendix XII).

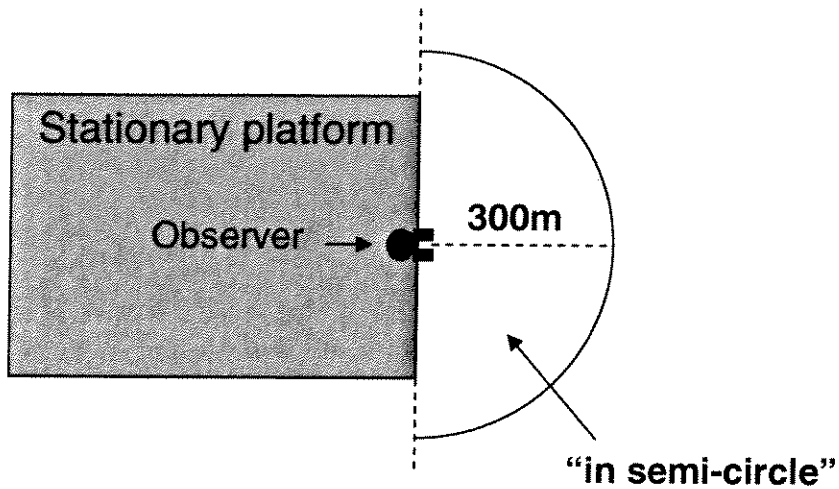
#### 4. LIST OF CONSULTED REFERENCES

- Anon. 2000. Seabirds Identification Guide: seabirds monitoring program for Terra Nova development drilling phase. Prepared for Terra Nova Development by Jacques Whitford Environment Limited.
- Baillie, S.M., Robertson, G.J., Wiese, F.K., and Williams, U.P. 2005. Seabird data collected by the Grand Banks offshore hydrocarbon industry 1999-2002: results, limitations and suggestions for improvement. Canadian Wildlife Service Technical Report Series No. 434. Atlantic Region. v + 47 pp.
- Camphuysen, C.J. and Garthe, S. 2004. Recording foraging seabirds at sea: standardised recording and coding of foraging behaviour and multi-species foraging associations. *Atlantic Seabirds* 6: 1-32.
- Heinemann, D. 1981. A range finder for pelagic bird censusing. *Journal of Wildlife Management* 45: 489-493.
- Komdeur, J., Bertelsen, J., and Cracknell, G. 1992. Manual for aeroplane and ship surveys of waterfowl and seabirds. IWRB Special Publication No. 19. National Environmental Research Institute, Department of Wildlife Ecology, Kalø, Denmark.
- Montevecchi, W.A. and Burke, C. 2002. Surveys of marine birds and mammals in Newfoundland waters from offshore support vessels and ships of opportunity. Report prepared for Environmental Studies Research Fund Management Board of Canada. Memorial University of Newfoundland, St. John's.
- Tasker, M.L., Hope Jones, P., Dixon, T., and Blake, B.F. 1984. Counting seabirds at sea from ships: a review of methods employed and a suggestion for a standardized approach. *Auk* 101: 567-577.
- Tasker, M.L., Hope Jones, P., Blake, B.F., Dixon, T.J., and Wallis, A.W. 1986. Seabirds associated with oil production platforms in the North Sea. *Ring and Migration* 7: 7-14.

**Appendix I. Example of survey using a 90° scan, covering a 300m transect from a moving platform. Record birds that are observed within this transect, whether flying or on the water, as a priority. Record all birds seen outside the transect, if this does not affect observations within the transect, and note them as “not in transect”.**



Appendix II. Example of survey using a 180° scan, covering a semi-circle of 300m radius from a stationary platform. Record birds observed within this area, whether flying or on the water, as a priority. Record all birds seen outside the 300m semi-circle as well, but note them as “not in semi-circle”.



**Appendix III. Estimating a 300m distance at sea using a slide calliper (formula derived by J. Chardine, based on Heinemann 1981).**

The 300m distance from the observation point can be estimated using a slide calliper and the following equation:

$$d_h = 1000 \frac{(ah3838\sqrt{h}) - ahd}{h^2 + 3838d\sqrt{h}} \quad \text{e.g. if } a = 0.714 \text{ m, } h = 15 \text{ m, and } d = 300 \text{ m}$$

then  $d_h = 35.0 \text{ mm}$

where:

$d_h$  = distance down from horizon down (mm)

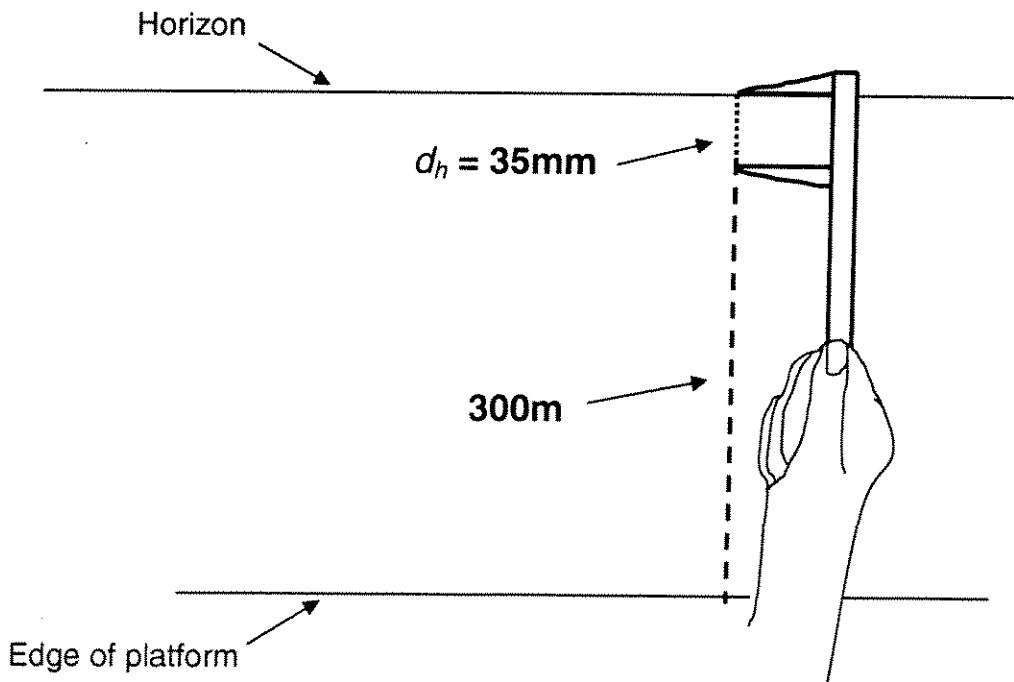
$a$  = distance between the observer's eye and the calliper when observer's arm is fully out-stretched (m)

$h$  = height of the observer's eye above the water at the observation point (m)

$d$  = distance to be estimated (m; in this case, the width of the transect or semi-circle, or 300m)

First, calculate  $d_h$  to obtain the amount that the calliper should be opened at for a 300m transect or semi-circle. Once this amount is known, hold the calliper vertically at arm's length, opened to the appropriate interval, with the tip of the upper jaw in line to the horizon. The tip of the lower jaw of the calliper is now in line with a distance 300m from the platform, marking the far side of the transect or semi-circle.

**Visual illustration of example above:**



**Appendix IV. Intervals at which instantaneous or “snapshot” counts of flying birds should be conducted within a ten-minute observation period, within a 300m transect from a moving platform.**

Platform's speed (knots)	Interval between counts (minutes)
4	2.5
5	2.0
6-8	1.5
9-12	1.0
13-19	0.5

## **Appendix V. Notes on completing Observation Period Information for a moving platform.**

**Platform name, agency and type:** Agency may include company (e.g., Shell, CN Marine, etc.), or government agency (e.g., DND, DFO, GGC). Type may include seismic ship, supply vessel, fishing boat, research ship, ferry, destroyer, etc.

**Date:** Date that the observation period occurred (use format 20 July 2004 to avoid ambiguity).

**Time start / Time end:** Time (using 24 hour notation) at the start and end of the ten-minute observation period. Use local (L) or Universal Time (UTC) and indicate which was used by circling appropriate letter or writing in appropriate space. If local, record as AST, EDT, etc., to avoid ambiguity.

**Latitude and longitude at start of observation period:** Indicate position of platform in either decimal degrees or degrees minutes seconds.

**Activity of moving platform:** Activity may include steaming, on patrol, fishing, conducting research, seismic array active or inactive, etc.

**Visibility:** Estimate visibility in km from 0.3 (which is 300m) to 20km; estimates should also be made on foggy days.

**Sea state code:** Use Sea state code from Appendix IX.

**Swell height:** Estimate the height of the swell, as this may also influence the detectability of the birds.

**Wind speed or force:** Indicate the speed of the wind in knots if recorded on the platform, or use Beaufort code from Appendix IX. If using the wind speed recorded from a moving platform, be sure to record the TRUE speed, as this takes into account the 'apparent' wind generated from the forward momentum of the vessel.

*Note on wind speed, sea state and Beaufort codes: Although there is often a direct relationship among these three variables (i.e., when sea state is a 2, Beaufort is a 3, and wind speed is between 7 and 10 knots), this is not always the case. For example, it may take some time for the state of the sea to reflect an increase in the wind speed. When possible, record the wind speed in knots and note the sea state using the descriptions in Appendix IX.*

**Wind direction:** Indicate compass direction (*N, NE, E, SE, S, SW, W, or NW*) of the wind. If using the wind direction recorded from a moving platform, be sure to record the TRUE direction, as this takes into account the 'apparent' wind generated from the forward momentum of the vessel.

**Platform speed (knots):** If speed changes during observation period, indicate new speed and time at which change occurred.



**Platform direction:** Indicate compass direction (*N, NE, E, SE, S, SW, W, or NW*); if this changes during observation period, indicate new direction and time at which change occurred.

**Observation side:** Circle *Starboard* or *Port*.

**Observer height (meters):** Indicate height of observer's eye above water from observation point in meters.

**Outdoors or Indoors:** Circle *Out* when conducting observations from a position outdoors and *In* for indoor observations.

**With snapshot?** Indicate if snapshot method for birds in flight is being used by circling *Y* or *N*.

## **Appendix VI. Notes on completing Scan Information for a stationary platform.**

**Platform name, agency and type:** Agency may include company (e.g., Shell, CN Marine, etc.), or government agency (e.g., DND, DFO, CCG). Type may include drilling rig, FPSO, supply vessel, seismic vessel, fishing boat, research ship, ferry, destroyer, etc.

**Date:** Date that the observation period occurred (use format 20 July 2004 to avoid ambiguity).

**Time start / Time end:** Time (using 24 hour notation) at the start and end of the ten-minute observation period. Use local (L) or Universal Time (UTC) and indicate which was used by circling appropriate letter or writing in appropriate space. If local, record as AST, EDT, etc., to avoid ambiguity.

**Latitude and longitude at start of scan:** Indicate position of platform in either decimal degrees or degrees minutes seconds.

**Platform activity:** Activity may include drilling, off-loading, etc.

**Scan type:** Indicate at which angle the scan is being conducted (recommended is 180°).

**Scan direction:** Indicate compass direction (*N, NE, E, SE, S, SW, W, or NW*) when looking straight ahead, at center of semi-circle.

**Visibility:** Estimate visibility in km from 0.3 (which is 30m) to 20km; estimates should also be made on foggy days.

**Sea state code:** Use Sea State code from Appendix IX.

**Swell height:** Estimate the height of the swell, as this may also influence bird detectability.

**Wind speed or force:** Indicate the speed of the wind in knots if recorded on the platform, or use Beaufort code from Appendix IX. If using the wind speed recorded from a moving platform, be sure to record the TRUE speed, as this takes into account the 'apparent' wind generated from the forward momentum of the vessel.

*Note on wind speed, sea state and Beaufort codes: Although there is often a direct relationship among these three variables (i.e., when sea state is a 2, Beaufort is a 3, and wind speed is between 7 and 10 knots), this is not always the case. For example, it may take some time for the state of the sea to reflect an increase in the wind speed. When possible, record the wind speed in knots and note the sea state using the descriptions in Appendix IX.*

**Wind direction:** Indicate compass direction (*N, NE, E, SE, S, SW, W, or NW*) of the wind. If using the wind direction recorded from a moving platform, be sure to record the TRUE direction, as this takes into account the 'apparent' wind generated from the forward momentum of the vessel

**Observer height (meters):** Indicate height of observer's eye above water from observation point in meters.

**Outdoors or Indoors:** Circle *Out* when conducting observations from a position outdoors and *In* for indoor observations.

## Appendix VII. Notes on completing Bird Information.

**Species:** Identify each individual bird seen to species. If this is not possible for various reasons (e.g., because of brief viewing opportunity, poor lighting condition, etc.), identify to genus or family. Record all unknowns, even if they are identified only as “gull” or “bird”.

**In transect or semi-circle?:** Indicate if bird observed is in (*Y*) or out (*N*) of the transect (moving) or semi-circle (stationary). Give priority to birds that are in the transect or semi-circle; record birds seen outside of the observation area if this does not affect “in-transect or semi-circle” observations.

**For moving platform, when are birds “in transect”?** Birds on the surface of the water within 300m from the mid-line of the platform are considered in transect. When visibility is good, birds on the water may be seen up ahead of the platform, perhaps as far as 400m or 500m ahead, but still within the 300m strip. Because these individuals may dive or fly away as a result of the approaching vessel, these should be counted as in transect and their perpendicular distance from the mid-line of the platform estimated. Flying birds, however, that are observed during a snapshot more than 300m ahead of the approaching platform are considered NOT in transect. In other words, count flying birds as in transect only if they are observed during a snapshot AND are within 300m perpendicular distance from the mid-line of the vessel and no farther than 300m ahead of the platform (see Appendix XI).

**Association and Behaviour:** Record one or more association and/or behaviour codes with each bird when appropriate (see Appendix X for association and behaviour codes, and refer to Camphuysen and Garthe (2004) for further information).

**Distance:** For birds observed on water, estimate the perpendicular distance between the bird(s) and the vessel within the following distance categories: *A* = 0-50m, *B* = 51-100m, *C* = 101-200m, *D* = 201-300m, and *E* = > 300m, *3* = within 300m but no distance recorded. Indicate when birds are in flight, and estimate their distance from the time they were first detected.

**Flight direction:** Indicate which compass direction (*N*, *NE*, *E*, *SE*, *S*, *SW*, *W*, or *NW*) birds in flight are heading if they are not associated with the platform. Ensure that a magnetic compass has been corrected for local declination.

**Age:** Age is based on plumage, where *J*(juvenile) = first coat of true feathers acquired before leaving nest and *I*(immature) = the first fall or winter plumage that replaces the juvenile plumage and may continue in a series that includes first-spring plumage, but is not the complete *A*(adult) plumage.

**Plumage:** Adult plumage can be further categorized, where *B*(breeding) = spring and summer plumage, *NB* (non-breeding) = fall and winter plumage, and *M*(molt) = transitional phase between these two plumages, often with some flight feathers are missing.

**Notes:** Space is provided to record other pertinent information, such as the presence of fishing vessels in the survey area, if a particular bird was carrying fish, etc.

**Appendix VIII. List of species code for seabirds seen within the Atlantic Waters of Canada's Exclusive Economic Zone (EEZ).**

Common name	Species code	Latin name
<b>COMMON, REGULAR OR FREQUENTLY SEEN SPECIES</b>		
Northern Fulmar	NOFU	<i>Fulmarus glacialis</i>
Greater Shearwater	GRSH	<i>Puffinus gravis</i>
Manx Shearwater	MASH	<i>Puffinus puffinus</i>
Sooty Shearwater	SOSH	<i>Puffinus griseus</i>
Wilson's Storm-Petrel	WISP	<i>Oceanites oceanicus</i>
Leach's Storm-Petrel	LHSP	<i>Oceanodroma leucorhoa</i>
Great Cormorant	GRCO	<i>Phalacrocorax carbo</i>
Double-crested Cormorant	DCCO	<i>Phalacrocorax auritus</i>
Northern Gannet	NOGA	<i>Morus bassanus</i>
Common Eider	COEI	<i>Somateria mollissima</i>
Red-breasted Merganser	RBME	<i>Mergus serrator</i>
Surf Scoter	SUSC	<i>Melanitta perspicillata</i>
Black Scoter	BLSC	<i>Melanitta nigra</i>
White-winged Scoter	WWSC	<i>Melanitta fusca</i>
Long-tailed Jaeger	LTJA	<i>Stercorarius longicaudis</i>
Parasitic Jaeger	PAJA	<i>Stercorarius parasiticus</i>
Pomarine Jaeger	POJA	<i>Stercorarius pomarinus</i>
Great Skua	GRSK	<i>Stercorarius skua</i>
Herring Gull	HERG	<i>Larus argentatus</i>
Iceland Gull	ICGU	<i>Larus glaucoides</i>
Glaucous Gull	GLGU	<i>Larus hyperboreus</i>
Great Black-backed Gull	GBBG	<i>Larus marinus</i>
Black-legged Kittiwake	BLKI	<i>Rissa tridactyla</i>
Common Murre	COMU	<i>Uria aalge</i>
Thick-billed Murre	TBMU	<i>Uria lomvia</i>
Razorbill	RAZO	<i>Alca torda</i>
Dovekie	DOVE	<i>Alle alle</i>
Atlantic Puffin	ATPU	<i>Fratercula arctica</i>
<b>CODES FOR BIRDS IDENTIFIED TO FAMILY OR GENUS ONLY</b>		
Unknown	UNKN	
Unknown Shearwater	UNSH	
Unknown Storm-Petrel	UNSP	
Unknown Jaeger	UNJA	
Unknown Gull	UNGU	
Unknown Tern	UNTE	
Unknown Alcid	ALCI	
Unknown Murre	UNMU	

## INFREQUENTLY OR RARELY SEEN BIRDS

---

Cory's Shearwater	COSH	<i>Calonectus diomedea</i>
Audubon's Shearwater	AUSH	<i>Puffinus lherminieri</i>
King Eider	KIEI	<i>Somateria mollissima</i>
Harlequin Duck	HARD	<i>Histrionicus histrionicus</i>
Long-tailed Duck	LTDU	<i>Clangula hyemalis</i>
Red Phalarope	REPH	<i>Phalaropus fulicaria</i>
Red-necked Phalarope	RNPH	<i>Phalaropus lobatus</i>
South Polar Skua	SPSK	<i>Catharacta maccormicki</i>
Ivory Gull	IVGU	<i>Pagophila eburnea</i>
Black-headed Gull	BHGU	<i>Larus ribindus</i>
Laughing Gull	LAGU	<i>Larus articilla</i>
Ring-billed Gull	RBGU	<i>Larus delawarensis</i>
Lesser Black-backed Gull	LBBG	<i>Larus fuscus</i>
Sabine's Gull	SAGU	<i>Xema sabini</i>
Common Tern	COTE	<i>Sterna hirundo</i>
Black Guillemot	BLGU	<i>Cepphus grylle</i>

---

**Appendix IX. Codes for sea state and Beaufort wind force.**

Wind Speed (knots)	Sea state code and description	Beaufort wind force scale code and description
0	0 Calm, mirror-like	0 calm
01 - 03	0 Ripples with appearance of scales but crests do not foam	1 light air
04 - 06	1 Small wavelets, short but pronounced; crests do not break	2 light breeze
07 - 10	2 Large wavelets, crests begin to break; foam of glassy appearance; perhaps scattered white caps	3 gentle breeze
11 - 16	3 Small waves, becoming longer; fairly frequent white caps	4 moderate breeze
17 - 21	4 Moderate waves with more pronounced form; many white caps; chance of some spray	5 fresh breeze
22 - 27	5 Large waves formed; white foam crests more extensive; probably some spray	6 strong breeze
28 - 33	6 Sea heaps up; white foam from breaking waves blows in streaks in direction of wind	7 near gale
34 - 40	6 Moderately high long waves; edge crests break into spindrift; foam blown in well-marked streaks in direction of wind	8 gale
41 - 47	6 High waves; dense streaks of foam in direction of wind; crests of waves topple and roll over; spray may affect visibility	9 strong gale
48 - 55	7 Very high waves with long overhanging crests; dense foam streaks blown in direction of wind; surface of sea has a white appearance; tumbling of sea is heavy; visibility affected	10 storm
56 - 63	8 Exceptionally high waves; sea is completely covered with white patches of foam blown in direction of wind; edges blown into froth; visibility affected	11 violent storm
64 +	9 Air filled with foam and spray; sea completely white with driving spray; visibility seriously affected	12 hurricane

**APPENDIX X. Codes for associations and behaviours of seabirds recorded during surveys at sea. Choose one or more as applicable. Refer to Camphuysen and Garthe (2004) for further information.**

**Associations**

*Associations*

- 10 Associated with fish shoal
- 11 Associated with cetaceans
- 13 Associated with line in sea
- 14 Sitting on or near floating wood
- 15 Associated with floating litter
- 16 Associated with oil slick
- 18 Associated with observation platform
- 20 Approaching observation platform
- 21 Associated with other vessel
- 23 Associated with offshore platform
- 26 Associated with fishing vessel
- 27 Associated with or on sea ice
- 28 Associated with land (e.g., colony)
- 50 Associated with other species feeding in same location

**Behaviours**

*Foraging behaviour*

- 30 Holding fish
- 31 Without fish
- 32 Feeding young at sea
- 33 Feeding
- 40 Scavenging
- 41 Scavenging at fishing vessel
- 49 Actively searching

*General behaviour*

- 60 Resting or apparently sleeping
- 64 Carrying nest material
- 65 Guarding chick
- 66 Preening or bathing

*Distress or mortality*

- 90 Under attack by kleptoparasite
- 96 Entangled in fishing gear or rope
- 97 Oiled
- 99 Dead



## Appendix XI. Example of a 10-min survey from a moving platform.

**XI.1. Scenario (see associated Figure Pg. 23 and datasheet Pg. 24):** We are travelling at 10 knots, so in 10 minutes we will travel a distance of about 3km (3.13km to be exact). Based on the speed of the vessel, we will count flying birds every minute (see Appendix IV). This means that the length of the 3km transect will be divided into 10 snapshot “boxes”, each 300m long and 300m wide – i.e., the width of the transect. At the start of each minute, we will record all birds flying within the current 300m x 300m snapshot box as “in transect”. Remember, we are continuously counting the birds we see on the water. Visibility is excellent, and we can likely detect the larger species at distances of about 500m.

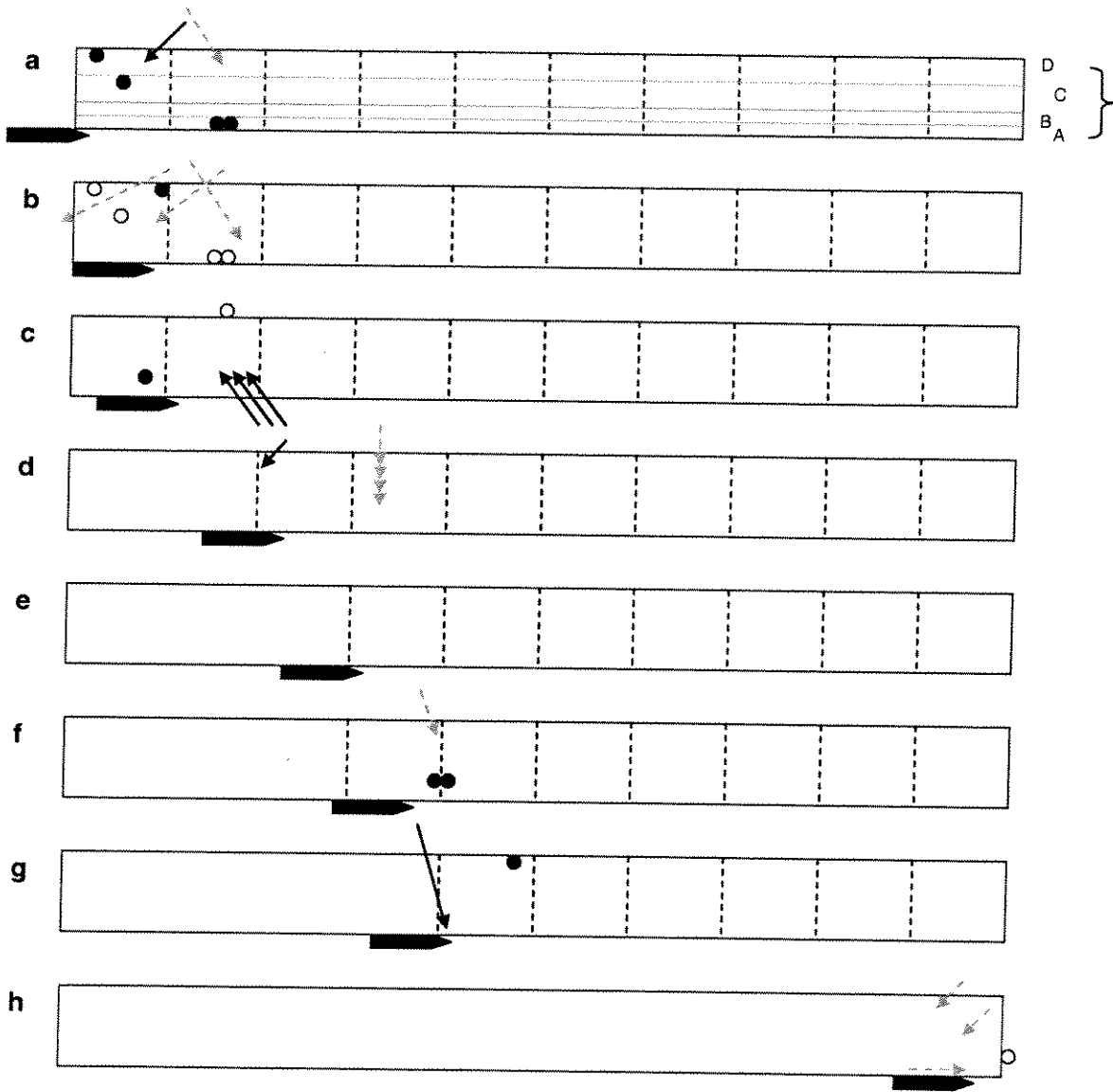
- a) We begin the observation period at 08:00 with a count of the birds we see on the water, as well as a snapshot of the flying birds. At this point, we can see 2 birds on the water to the port side of the vessel, at distances C and D (see Appendix VII). We can also see 2 birds together on the water, more than 300m in front of the vessel. We will also count these as “in transect”, although we will be careful not to count them again as we get closer. We see a total of 2 flying birds within the 300m transect, although we will only count one as “in transect”, as the other is more than 300m in front of the vessel.
- b) Now we are about 30 seconds into the 10 min observation period, **in between** snapshot counts. We have already counted 4 of the birds on the water (shown in the figure as open circles), but another has appeared at distance D, and we add this to our list as “in transect”. Despite the appearance of a new flying bird within 300m of the vessel, we do not count it as “in transect”, as we are in between snapshots. We may add the new bird to our list, but indicate that it is NOT in transect.
- c) At minute 1, we take another instantaneous count of flying birds within 300m of the ship. A flock of 3 birds is seen at distance B traveling NW. We also see one new bird on the water at distance B, and one outside 300m (distance category E). These are all “in transect” except for the bird at distance E.
- d) At minute 2, we count one flying bird in transect at distance D, travelling SW. Because the density of birds observed is relatively low, and we have the time to record, we note the flock of 4 birds flying south ahead of the vessel, but do NOT count them as “in transect”, as they are beyond 300m in front of the ship. Because the birds are spread out across several distance categories when they were first observed (but clearly flying together), we note the distance as “3”. We see no new birds on water over the next minute.
- e) At minute 3, no new birds are observed, so nothing new is written on our data sheet.
- f) As we continue, we DO NOT count the new flying bird we see as “in-transect” because we are now in between snapshots, but if time permits, we will record it as NOT in transect. We will record the 2 birds feeding up ahead on the water, both “in transect”. Since one is a juvenile and one is an adult, we enter them on the datasheet in two rows, linking the two with a line in the left margin.

- g)** At minute 4, our next 'snapshot' takes place, and we see that the bird we saw earlier (see frame f) can now be recorded as "in transect", as it is within 300m of the vessel AND observed during the snapshot. We record the flying distance as D, as that is the distance that we first saw the bird. If we know for certain that this is the same individual we previously recorded as NOT in transect (frame f), we can cross the previous observation out. If we are not certain that this is the same individual we do not cross anything out. There is also a new bird on the water at distance D.

This procedure continues throughout the 10 min period, counting birds observed on the water continuously, and counting flying birds during 1 min snapshots. Recording birds on the water outside of the 300m wide transect, and flying birds in between snapshots can be done if it does not affect observations within the transect.

- h)** As we approach the end of the 10 min observation period, we note the bird at distance A that has been following us. Remember, you must record ship-followers as "associated with platform" (code 18). And we do not include the bird we can see about 350m ahead of the vessel, because by the time we reach it, the 10 min observation period will be over, and the bird will be counted in the next period.

**XI.2. Scenario Figure (adapted from Tasker et al. 1984).** An example of a 10 min observation period with birds shown on the water (points) and flying (arrows). Open points and arrows with dashed lines are meant to show those birds that are not to be counted as “in transect”. Based on the speed of the vessel, instantaneous counts (snapshots) will be made for flying birds at 1-min intervals, represented here by the vertical dashed lines. The horizontal lines shown in ‘a’ represent the bands for distance categories.



**XI.3. Datasheet**

**Ten-minute period record sheet for a moving platform**

**Observation Period Information:**

Company/agency	<b>DFO</b>	Sea state code	<b>3</b>
Platform name and type	<b>Teleost, DFO Research</b>	Swell height (m)	<b>2</b>
Observer (s)	<b>Carina Gjerdrum</b>	Wind speed (knots) <b>OR</b> Beaufort code	<b>17 knots</b>
Date (Day Month Year)	<b>15 May 2006</b>	Wind direction	<b>SSE</b>
Time at start ( UTC or L )	<b>0800 L (NLT)</b>	Platform speed (knots)	<b>10</b>
Time at end (UTC or L )	<b>0810 L</b>	Platform direction	<b>E</b>
Latitude at start	<b>45° 02.535</b>	Observation side	<b>Starboard</b> <input type="radio"/> <b>Port</b> <input checked="" type="radio"/>
Longitude at start	<b>45° 33.751</b>	Observer's height (meters)	<b>12</b>
Platform activity	<b>steaming</b>	Outdoors or Indoors	Out <input type="radio"/> or <b>In</b> <input checked="" type="radio"/>
Visibility (kilometres)	<b>15 km</b>	Snapshot Used?	<b>Yes</b> <input checked="" type="radio"/> or No <input type="radio"/>

*Notes:*

Crab fishing activity in area

**Bird Information:**

\*this field must be completed for each record

* Species	* Count	* Fly or Water?	* In transect ?	* Distance <sup>1</sup>	Assoc.	Behav.	Flight Direc. <sup>2</sup>	Age <sup>3</sup>	Plum. <sup>4</sup>	Sex	Comments
<b>a)</b>	1	W	Y	C							
	1	W	Y	D							
	2	W	Y	A							
	1	F	Y	D			SW				
	1	F	N	D			SE				
<b>b)</b>	1	W	Y	D							
	1	F	N	C			SW				
<b>c)</b>	3	F	Y	B			NW				
	1	W	Y	B							
	1	W	N	E							
<b>d)</b>	1	F	Y	D			SW				
	4	F	N	3			S				
<b>f)</b>	1	F	N	D			SE				
	1	W	Y	B		33		I			
	1							A			
<b>g)</b>	1	F	Y	D							
	1	W	Y	D							
<b>h)</b>	1	F	N	A	18						

<sup>1</sup> A = 0-50m, B = 51-100m, C = 101-200m, D = 201-300m, E = > 300m, 3 = within 300m but no distance.

<sup>2</sup> Indicate compass direction (N, NE, E, SE, S, SW, W, or NW); ND = no apparent direction

<sup>3</sup> J(juvenile), I(immature), or A(dult)

<sup>4</sup> B(reeding), NB(non-breeding), M(out)

**Appendix XII. Example of completed record sheet for a stationary platform.**

**Record sheet for a stationary platform**

**Scan Information:**

Company/agency	Canadian Superior	Scan type	180° or other (specify: )
Platform name and type	Drill Rig RG-5	Scan direction	SW
Observer (s)	Jason Snipe	Visibility (kilometres)	1
Date (Day Month Year)	15 August 2005	Sea state code	4
Time at start (UTC or L)	12:50 UTC	Swell height (m)	1
Time at end (UTC or L)	12:54 UTC	Wind speed (knots) OR Beaufort code	5 (Beaufort scale)
Latitude at start	43° 54.086N	Wind direction	NW
Longitude at start	63° 26.391W	Observer's height (meters)	15
Platform activity	Not drilling	Outdoors or Indoors	Out or In

**Notes:**

**Bird Information:**

\*this field must be completed for each record

* Species	* Count	* Fly or Water?	* In semi-circle?	* Distance <sup>1</sup>	Assoc.	Behav.	Flight Direc. <sup>2</sup>	Age <sup>3</sup>	Plum. <sup>4</sup>	Sex	Comments
HERG	1	F	N	E			NW				
HERG	6	F	Y	C	18		ND	I			
BLKI	3	W	Y	C		60		A	B		
BLKI	1							J			
COMU	1	W	Y	A		65		A	B		
COMU	1							J	B		
GBBG	9	F	N	B	50	41	ND	A	B		
GBBG	5							I			
NOFU	4							A	B		light morph
ALCI	1	W	Y	W				A	B		

<sup>1</sup> A = 0-50m, B = 51-100m, C = 101-200m, D = 201-300m, E = > 300m, 3 = within 300m but no distance.

<sup>2</sup> Indicate compass direction (N, NE, E, SE, S, SW, W, or NW); ND = no apparent direction

<sup>3</sup> J(juvenile), I(mmature), or A(dult)

<sup>4</sup> B(reeding), NB(non-breeding), M(oult)

**Appendix XIII. Check-list of materials required while conducting seabird surveys.**

- Multiple pens or sharp pencils (**required**)
- Multiple copies of blank recording sheets (**required**)
- Binoculars (**required**)
- Hand-held Global Positioning System (GPS) to determine platform position, vessel speed and vessel direction (**required**)
- Watch or clock (**required**) - with countdown timer that can beep on snapshot intervals would be preferred
- Compass or GPS to determine flight direction of birds (**required**)
- Copy of protocol (recommended)
- Spotting telescope (recommended)
- Seabird identification guide (recommended)
- Slide calliper or range finder (recommended)
- Warm and waterproof clothing (recommended)
- Calculator if using slide calliper to determine 300m observation distance (recommended)

## **Appendix XIV**

### **Blank record sheets for moving and stationary platforms**







APPENDIX D

ENVIRONMENTAL STEWARDSHIP PLAN



NWest Energy Ltd.

---

***Environmental Stewardship Plan***

**TABLE OF CONTENTS**

**1.0 introduction..... 4**

    1.1 Scope .....4

    1.2 Waste Management and Conservation .....4

**2.0 ENVIRONMENTAL STEWARDSHIP roles and Responsibilities ..... 4**

**3.0 Legislative Requirements – Onshore..... 5**

    3.1 Environment Act & Regulations .....5

    3.2 Federal.....5

    3.3 Municipal.....6

    3.4 Other .....6

**4.0 Legislative Requirements – Offshore..... 6**

    4.1 Provincial.....6

    4.2 Atlantic Accord Acts (AAA) .....6

    4.3 Federal.....6

**5.0 Training..... 7**

**6.0 Regulated Discharges..... 8**

**6.1 Bilge Water ..... 8**

        6.1.1 Regulatory Requirements ..... 8

        6.1.2 Handling and Disposal Procedure ..... 8

**6.2 Ballast Water..... 8**

        6.2.1 Regulatory Requirements ..... 8

        6.2.2 Handling and Disposal Procedure ..... 8

**6.3 Deck Drainage ..... 8**

        6.3.1 Regulatory Requirements ..... 9

        6.3.2 Handling and Disposal Procedures ..... 9

**6.4 Cooling Water ..... 9**

        6.4.1 Regulatory Requirements ..... 9

        6.4.2 Handling and Disposal Procedure ..... 9

**6.5 Sanitary and Food Wastes ..... 9**

        6.5.1 Regulatory Requirements ..... 9

        6.5.2 Handling and Disposal Procedure ..... 10

**6.6 Oily Wastes ..... 10**

        6.6.1 Regulatory Requirements ..... 10

        6.6.2 Handling and Disposal Procedure ..... 10

---

<b>6.7</b>	<b>Monoethylene Glycol (MEG)</b> .....	<b>10</b>
6.7.1	Regulatory Requirements .....	10
6.7.2	Handling and Disposal Procedure .....	10
<b>6.8</b>	<b>Air and Greenhouse Gas Emissions</b> .....	<b>11</b>
<b>7.0</b>	<b>Marine Bunkering Processes</b> .....	<b>11</b>
<b>8.0</b>	<b>Environmental Monitoring</b> .....	<b>11</b>

## 1.0 INTRODUCTION

This Environmental Stewardship Plan (ESP) for NWest Energy Ltd. includes specific procedures for meeting environmental compliance and monitoring requirements and for managing waste streams for operations offshore Newfoundland and Labrador. This includes discharges typically generated during offshore exploration activity, regulated under the Offshore Waste Treatment Guidelines (2002).

As operator of exploration activities on its properties, NWest is ultimately responsible for all activities undertaken under its authorizations and approvals. The purpose of the ESP is to communicate to NWest employees, contractors and stakeholders NWest's expectations for environmental management with respect to exploration activities offshore Newfoundland & Labrador.

### 1.1 Scope

The primary audience for the ESP is the employees of NWest, and its contractors who are responsible for environment, health and safety (EHS) on NWest projects offshore Newfoundland. Other interested parties would include regulatory and government officials having jurisdiction over NWest's activities.

### 1.2 Waste Management and Conservation

In many cases, waste minimization practices can result in improved operating efficiency, cost savings and increased revenue for the company. NWest's commitment to Environmental Stewardship will lead to the long-term viability of its operations and to a competitive advantage, while benefiting the environment.

The "Contractor's" Waste Management Plan provide information on environmental stewardship with respect to waste minimization and source reduction. It also provides information on pollution prevention with respect to the proper handling and disposal of wastes.

NWest is committed to abide by the Offshore Chemical Selection Guidelines to reduce the use and discharge of potentially harmful chemicals where practicable.

## 2.0 ENVIRONMENTAL STEWARDSHIP ROLES AND RESPONSIBILITIES

The Contractor's Waste Management Procedure will be utilized to the fullest extent possible. The Captain will be responsible for the implementation and utilization of this procedure for "Contractor". NWest is responsible to ensure "Contractor" is communicating the onboard Waste Management system to contractors, as well as to NWest personnel. NWest is responsible for communicating the Waste Management System to its contractors through awareness programs and internal communications facilitated jointly by "Contractor" and NWest. Waste Management will be addressed with vessel crews during orientations and training events prior to commencement of, and during operations.

The **Vessel Captain or designate** will have overall accountability for all waste management issues. This person will be directly responsible for the waste management plan on behalf of NWest.

## **3.0 LEGISLATIVE REQUIREMENTS – ONSHORE**

### **3.1 Environment Act & Regulations**

#### **The Newfoundland and Labrador Environmental Protection Act**

#### **Occupational Health and Safety Act and Regulations**

The provincial government has the primary responsibility for the regulation of occupational health and safety onshore. Similarly, the provincial government regulates the handling, transport and disposal of solid and hazardous wastes once they are transported onshore.

#### **Workplace Hazardous Materials Information System (WHMIS) Regulations**

WHMIS defines the safety requirements for personnel who are handling hazardous materials. These requirements include training, protective equipment and product labeling.

### **3.2 Federal**

#### **Canadian Environmental Protection Act (CEPA)**

The goal of the *Canadian Environmental Stewardship Act (CEPA)* is to contribute to sustainable development through pollution prevention and to protect the environment, human life and health from the risks associated with toxic substances. CEPA controls toxic substances (Sections 64-103) by

- establishing a firm time frame for a response and follow up action
- requires all substances on the Domestic Substances List to be categorized and screened for potential risks to human health, life and the environment
- sets a new goal of virtual elimination of persistent, bioaccumulating, toxic substances

The federal government also has the jurisdictional responsibility for environmental Stewardship on property owned, operated or regulated by the Canadian government.

#### **Transportation of Dangerous Goods Clear Language Edition**

August 2002 (TDG) – The TDG Regulations cover the documentation, packaging, labeling, and placarding requirements of waste materials that are considered to be hazardous. This Act also requires those handling the dangerous goods to be adequately trained.

Hazardous waste management primarily falls under CEPA, however, as an interim measure, a CEPA regulation has been established which has adopted all waste related requirements previously found in the TDG Act and Regulations.

The Atomic Energy Control Act and Regulations must be followed for the management and disposal of prescribed radioactive substances as defined by the Canadian Nuclear Safety Commission

### **3.3 Municipal**

Municipal bylaws will also apply where waste is deposited in municipal landfill.

### **3.4 Other**

Where wastes are shipped out of province for disposal or treatment, the legislative requirements of those provinces or states will be applicable.

## **4.0 LEGISLATIVE REQUIREMENTS – OFFSHORE**

The following pieces of legislation are relevant to the management of wastes from offshore operations:

### **4.1 Provincial**

Occupational Health and Safety Act and Regulations, and the WHMIS regulations apply to offshore personnel who are handling hazardous materials.

### **4.2 Atlantic Accord Acts (AAA)**

The AAA are the governing legislation for petroleum activities undertaken in the Newfoundland & Labrador offshore area. These are the primary regulatory instruments for oil and gas exploration activities offshore Newfoundland and Labrador.

#### **CNLOPB Regulations**

These regulations apply to every operator who explores or drills for petroleum under the Atlantic Accords Act; and in respect of every well and test hole drilled under the Act, and is regulated by the Canada-Newfoundland & Labrador Offshore Petroleum Board.

#### **Installation Regulations**

The Installation Regulations are established for the purpose of ensuring the safety of offshore installations. An operator shall not be permitted to use the installation unless the equipment on the installation is arranged in accordance with these Installation Regulations. The regulations provide for the safety of personnel, minimization of damage to the environment; and will enable easy access to the equipment onboard the installation.

### **4.3 Federal**

#### **Transportation of Dangerous Goods Clear Language Edition**

August 2002 (TDG) - The TDG Regulations set the requirements for land, sea, and air transportation. Specifically, the Regulations require that the International Marine Dangerous Goods (IMDG) Code be followed for shipments by sea and the International Air Transport Association (IATA) Dangerous Goods Regulations be met for shipments by air.



### **Canada Shipping Act (CSA)**

Under the auspices of Transport Canada, the CSA outlines the requirements for transporting of wastes by vessels from the platform.

### **Atomic Energy Control Act and Regulations**

This Act must be followed for the management and disposal of prescribed radioactive substances as defined by the Canadian Nuclear Safety Commission.

### **Canada Fisheries Act**

Subsection 36(3) of the *Fisheries Act* states that “no person shall deposit or permit the deposit of a deleterious substance of any type in water frequented by fish”. Section 34 of the Act defines “deleterious” as “any substance” or “any water that contains a substance in such quantity or concentration, or that has been so treated, processed or changed, by heat or other means, from a natural state that it would” if added to any water “degrade or alter or form part of a process of degradation or alteration of the quality of that water so that it is rendered or is likely to be rendered deleterious to fish or fish habitat or to the use by man or fish that frequent that water”. Section 36(3) of the Act is administered by Environment Canada.

### **Migratory Birds Regulations**

The *Migratory Birds Regulations* under the *Migratory Birds Convention Act* prohibit the deposit of oil, oil wastes or any other substances harmful to migratory birds in waters frequented by migratory birds. Under Section 4(1) of the *Migratory Birds Regulations*, the Canadian Wildlife Service issues a Temporary Rehabilitation Permit to handle stranded, oiled or otherwise injured live seabirds.

### **Canadian Environmental Stewardship Act (CEPA) (1999)**

This Act encourages voluntary pollution prevention planning, however, under the authority of this Act, the Minister of Environment can require a company or facility to prepare and implement a pollution prevention plan to deal with substances that have been added to the List of Toxic Substances as a result of (their) business activities (Schedule 1 of the Act). The Act also applies to the importation of chemicals into Canada.

## **5.0 TRAINING**

NWEST will conduct Emergency Response training sessions with its onshore and offshore staff and selected contractors, and conduct exercises prior to commencement of exploration activities.

In the event of a significant spill at sea, the St. John's Emergency Operations Center will serve a dual purpose as an oil spill response center.

## **6.0 REGULATED DISCHARGES**

### **6.1 Bilge Water**

Bilge water often contains oil and grease that originate in the engine room and machinery spaces. The "Vessel" uses International Maritime Organization (IMO) approved 15 PPM oil content monitors, in series with an IMO approved Oily Water Separator (OWS) to monitor the oil content in the bilge water.

#### **6.1.1 Regulatory Requirements**

The OWTG requires that bilge water be treated to levels of 15 mg/L or less prior to ocean discharge. Oil concentrations in the discharge greater than 15 mg/L are considered to have exceeded normal operating practice and should be reported within 24 hours to the C-NLOPB Chief Conservation Officer.

#### **6.1.2 Handling and Disposal Procedure**

Bilge water, will be collected and tested following "Contractor's" program and, if necessary, treated to ensure that oil concentrations in the discharge do not exceed 15 mg/l (August 2002). Any oil concentrations above 15 mg/L will either be re-treated, or will be contained and sent to shore for disposal.

As previously discussed above, the "Vessel's" machinery rooms bilge systems all pass through an IMO approved oily water centrifuge, which is monitored by an IMO approved oil content monitor. Everything over 15 ppm is recirculated back into the system on the "Vessel". Discharge of bilge water is only done if the oil in water concentration is below 15ppm.

### **6.2 Ballast Water**

On seismic and support vessels, ballast water is stored in dedicated ballast tanks to control and maintain vessel stability.

#### **6.2.1 Regulatory Requirements**

Ballast water falls under the requirements of the OWTG; requiring water to be treated to levels of 15 mg/L or less prior to ocean discharge. Oil concentrations in the discharge greater than 15 mg/L are considered to have exceeded normal operating practice and should be reported within 24 hours to the C-NLOPB Chief Conservation Officer.

#### **6.2.2 Handling and Disposal Procedure**

With respect to the "Vessel", the ballast system does not mix with any other system it is 100% independent. Seawater is taken in for ballasting and seawater is pumped out for deballasting. There is no chlorination or other chemical treatment taking place. The ballast water will not be monitored.

### **6.3 Deck Drainage**

Deck drainage is water that reaches the deck of the "Vessel", through precipitation and/or condensation. Clean deck water will be discharged direct to sea. Deck water may be contaminated by hydrocarbons through runoff from vessel surfaces or maintenance of deck equipment.

### **6.3.1 Regulatory Requirements**

The OWTG require deck drainage that may be contaminated with oil to be treated to reduce its oil concentration to 15 mg/L or less. Oil concentrations in the discharge greater than 15 mg/L are considered to have exceeded normal operating practice and should be reported within 24 hours to the C-NLOPB Chief Conservation Officer.

### **6.3.2 Handling and Disposal Procedures**

Deck drainage will be collected via drain systems located in strategic locations onboard the "Vessel". Drainage systems are divided into specific areas or zones, based on the likelihood of the drainage water containing oil or other contaminants. Drainage is routed to specific tanks based on the oil in water (OIW) content, and either prepared for discharge or rerouted into the drainage system for further treatment or preparation for shipping to shore-base for disposal at an approved facility.

Deck drainage that is contaminated with oil will be treated to reduce concentrations to levels of less than 15 mg/L prior to discharge.

## **6.4 Cooling Water**

The cooling system used on the "Vessel" is a sea water cooling system, and the discharge water is not tested.

### **6.4.1 Regulatory Requirements**

As per the OWTG, the C-NLOPB Chief Conservation Officer may impose restrictions on the level of residual chlorine (if used) in cooling water being discharged from closed loop cooling systems, thereby requiring compliance testing prior to discharge. If biocide agents other than chlorine are used in the cooling water, they must be approved by the C-NLOPB Chief Conservation Officer and be evaluated against the OCSGs.

### **6.4.2 Handling and Disposal Procedure**

As previously discussed, the sea water cooling system is not tested, the sodium hypochlorite that is initially converted from the sodium chloride in the seawater, decays and reverts back to sodium chloride and is discharged back to the sea. If applicable, proposals for the use of chlorine and other biocides will be submitted to the C-NLOPB Chief Conservation Officer by NWest. Selection criteria in the OCSG will be applied to evaluate the use of the proposed biocide.

## **6.5 Sanitary and Food Wastes**

Grey water discharge (showers, dishwashing, deck drains, etc.) and black water discharge (sanitary waste) will be generated.

### **6.5.1 Regulatory Requirements**

The OWTG require sanitary and food waste to be reduced through maceration to a particle size of 6 mm or less prior to discharge. Additional treatment may be required by the C-NLOPB Chief Conservation Officer.

### **6.5.2 Handling and Disposal Procedure**

Sanitary and food waste will be macerated on the “Vessel” and support vessels to a particle size of 6 mm or less and then discharged as per the OWTG. The discharge of sanitary and food wastes are not measured onboard the “Vessel”

## **6.6 Oily Wastes**

Oily wastes include used oils (e.g., petroleum or synthetic lubrication oils, hydraulic fluids, etc.), industrial waste fuels, and gasoline. It also includes hydrocarbon contaminated liquids (oil at concentration >15 mg/L), bilge water, and deck drainage contaminated with oil at concentrations >15 mg/L, which cannot be discharged to the ocean due to mechanical failure of treatment equipment.

### **6.6.1 Regulatory Requirements**

The OWTG do not permit ocean discharge of oily wastes. These wastes must be brought to shore for treatment and disposal and are therefore subject to provincial regulations. The *Used Oil Control Regulations* under the *Environmental Stewardship Act* require used oil to be collected by an approved used oil collector or transported to a used oil return facility. Oily waste classified as “dangerous waste” (refer to TDGA Regulations) must be handled and stored according to the Newfoundland and Labrador *Used Oil Control Regulations* and transported according to the *TDG Act* and Regulations.

### **6.6.2 Handling and Disposal Procedure**

Oily wastes are brought to shore for processing by a licensed hauler to an approved facility for processing and recovery of waste petroleum based products. To determine whether the waste is classified as dangerous and therefore has specific transportation requirements, the waste will be sampled and classified.

## **6.7 Monoethylene Glycol (MEG)**

Monoethylene glycol (MEG) is used to prevent freezing of equipment in cold weather environments.

### **6.7.1 Regulatory Requirements**

The discharge of MEG requires the prior approval of the Chief Conservation Officer. A monthly report of discharged MEG concentrations and an estimate of the equivalent tonnage discharged, also should be prepared and submitted to the CCO.

### **6.7.2 Handling and Disposal Procedure**

Glycol containers and glycol contaminated wastes will be shipped to shore and disposed of as a hazardous waste.

## **6.8 Air and Greenhouse Gas Emissions**

The "Vessel" is equipped with recent technology combustion diesel engines ensuring maximum operating efficiency with reduced fuel consumption and reduced air emissions (CO/CO<sub>2</sub>/NO<sub>x</sub>).

## **7.0 MARINE BUNKERING PROCESSES**

A Marine Bunkering Procedure which is in alignment with the UKOOA document *Safe Management and Operation of Offshore Support Vessels, Issue 4, November 2002* will be utilized.

In the event of a spill occurring during bunkering operations, it will be reported immediately to the Canadian Coast Guard Marine Communication and Traffic Service , and the CCO.

## **8.0 ENVIRONMENTAL MONITORING**

NWEST will implement environmental monitoring programs during West Coast Exploration activities through the collection of marine mammal and seabird sightings from the "Vessel" based on the most recent protocol issued by the Canadian Wildlife Service.

**TABLE OF CONTENTS**

**1.0 INTRODUCTION ..... 3**

1.1 Corporate Statement ..... 3

1.2 Regulatory Compliance ..... 3

1.3 General Project Description ..... 3

1.4 Purpose of the Exploration Operations Emergency Response Plan ..... 5

1.5 Primary Objective of the Emergency Response Plan ..... 5

1.6 Related and / or Specific Emergency Response Documents ..... 5

1.7 Command Authority – Offshore Person in Command - “VESSEL” ..... 5

1.8 Command Authority – Onshore Project Manager ..... 6

1.10 Geographical Areas and Facilities Covered by the ERP ..... 6

1.11 Supply and Chase Vessels ..... 6

1.12 Standby Helicopter ..... 6

**2.0 EMERGENCY ORGANIZATION AND COMMUNICATIONS..... 6**

2.1 Introduction..... 6

2.2 Emergency Management Structure Overview ..... 6

2.3 Local Emergency Operations Centre (LEOC) Location ..... 7

2.4 Contractors Representative to Form Part of NWest’s LEOC ..... 7

2.6 LEOC Call-Out Protocol (From “VESSEL” or Other Location)..... 7

2.9 Communications Diagram (All Responders) ..... 8

2.10 Notification Flowchart (All Responders) ..... 9

2.11 Police Jurisdiction (RNC) ..... 10

2.12 Tactical Support (RNC) ..... 10

2.13 Police Jurisdiction (RCMP) / Suspension of Operations After an Incident ..... 10

2.14 Tactical Support (RCMP) – “VESSEL” Incident ..... 10

2.15 Bomb Threats / Bomb Detonation (RCMP)..... 10

2.16 Terrorism and Hostage Taking (RCMP) ..... 11

2.17 Notification of Accidents and Emergencies (RCMP / RNC)..... 11

2.18 Family & Next of Kin Notification (RCMP / RNC)..... 11

2.19 Suspension of Operations ..... 12

**3.0 ALERT CRITERIA / EMERGENCY LEVEL..... 12**

3.1 Declaring an Alert and Emergency ..... 12

3.2 Alert / Emergency Notification to the JRCC / MRSC ..... 12

**ACRONYMS**

AOMS	Atlantic Offshore Medical Services (St. John's)
CCG	Canadian Coast Guard
CISD	Critical Incident Stress Debriefing
C-NLOPB	Canada-Newfoundland and Labrador Offshore Petroleum Board
CPA	Closest Probable Approach
DFO	Department of Fisheries and Oceans
ECRC	Eastern Canada Response Corporation
EL	Exploration License
ECC	Emergency Control Centre ("VESSEL")
EFAP	Employee and Family Assistance Program
EMS	Emergency Medical Services
EPM	Emergency Preparedness Manual
ERP	Emergency Response Plan
FRC	Fast Rescue Craft
GMDSS	Global Maritime Distress and Safety System
GPA	General Platform Alarm.
HES	Health, Environment and Safety
HRC	Human Resources Coordinator
ICS	Incident Command System
JRCC	Joint Rescue Coordination Centre (Halifax)
LEP	Law Enforcement Personnel
LEOC	Local Emergency Operations Centre (St. John's)
MRSC	Marine Rescue Sub Centre (St. John's)
MTRC	Media Telephone Responders Centre
MV	Motor Vessel
NM	Nautical Mile
NOK	Next of Kin
OEMS	Offshore Emergency Management System
OH&S	Occupational Health and Safety
ERP	Emergency Response Plan
OPITO	Offshore Petroleum Industry Training Organization
OSC	On-Scene Commander
OSRL	Oil Spill Response Limited
PAC	Public Affairs Coordinator
POB	Personnel on Board
RCMP	Royal Canadian Mounted Police
RNC	Royal Newfoundland Constabulary
SAR	Search and Rescue
SBV	Standby Vessel
TRU	Tactical Rescue Unit
VAR	Victim's Assistance Representative

## **1.0 INTRODUCTION**

### **1.1 Corporate Statement**

The NWest Energy Limited Emergency Response Plan (ERP) has been developed in keeping with the Operator's Health, Environmental and Safety Policies and with a high regard for the safety of the public and our workers as well as protection of the environment.

### **1.2 Regulatory Compliance**

The ERP has been designed to meet all requirements as set forth by Section 64 of the Newfoundland Petroleum Offshore Exploration Regulations and Section 17.9 of the Newfoundland Petroleum Occupational Health and Safety Regulations (Draft).

### **1.3 General Project Description**

The Exploration Program will consist of a planned Summer 2008 seismic survey on Exploration Licenses (ELs) 1097, 1098, 1103 and 1104 located in the Exploration area on the West Coast of Newfoundland. All ELs are within Canada's territorial waters. The planned 2008 survey will not cover all EL's but will focus on a smaller area of approximately 700-1000km<sup>2</sup>. Refer to Figure 1 for a map of NWest's project area.

At the time of ERP preparation, an official announcement of the seismic vessel contractor has not been made. Therefore, this ERP will refer to the seismic vessel as "Vessel" and will be updated when the contractor has been finalized.



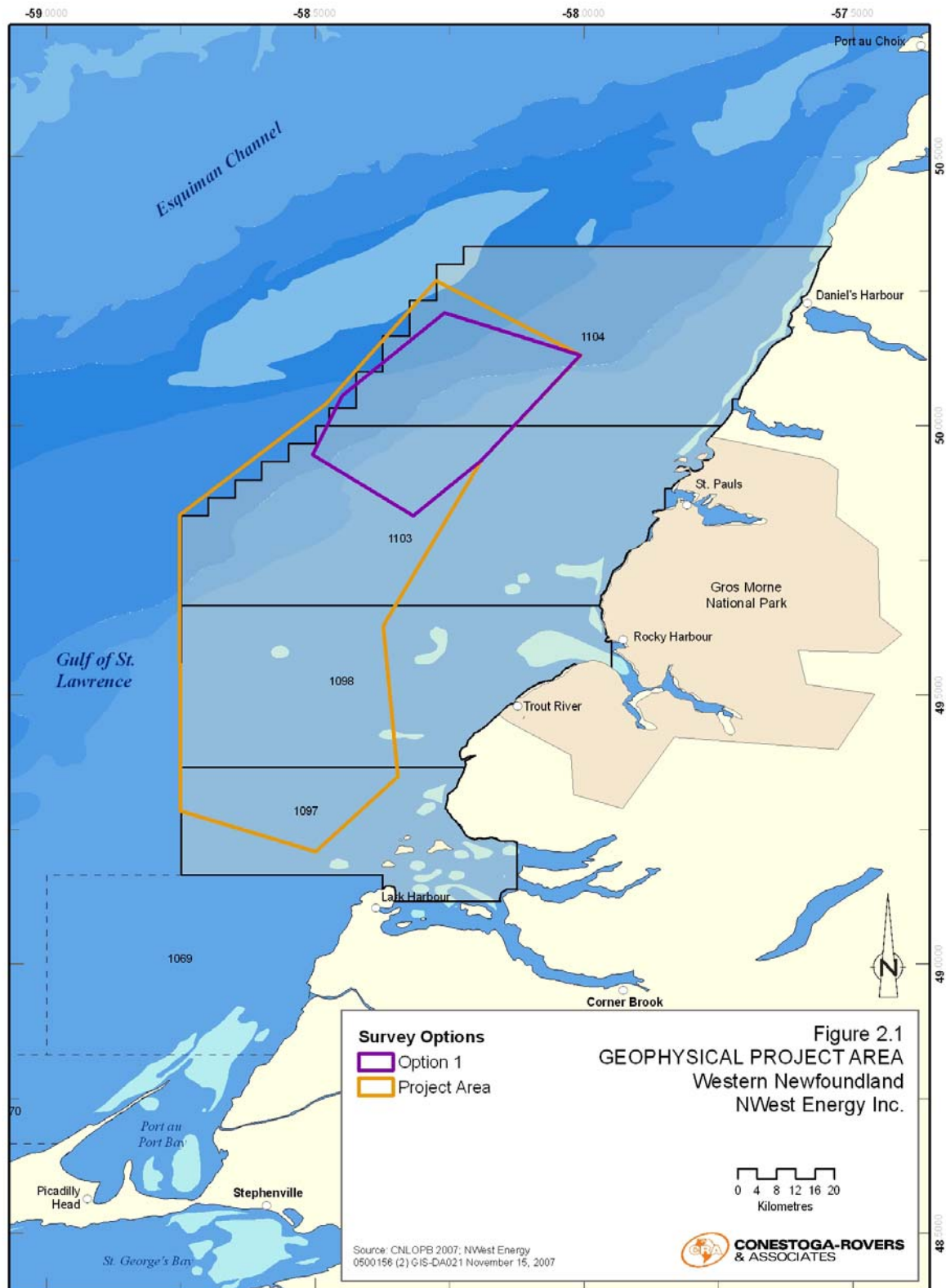


Figure 1 - Planned project area for NWest marine seismic acquisition program.

#### 1.4 Purpose of the Exploration Operations Emergency Response Plan

The purpose of the ERP is to assign responsibilities to specific individuals within the Exploration Operations Team during an emergency and to provide key linkages between the “VESSEL”’s Emergency Preparedness Manual. Accordingly, the ERP will, after training, provide onshore and offshore response personnel with the ability to:

- (a) Effectively organize emergency response / support personnel.
- (b) Execute all necessary emergency support actions.
- (c) Clearly communicate emergency roles and responsibilities.
- (d) Communicate effectively utilizing those protocols specific to marine emergencies within Canadian waters.

The ERP provides clear and concise guidance for **EMERGENCY SUPPORT** actions to be taken under all emergency scenarios that could reasonably be expected to occur during the Exploration Program. An emergency is defined as any unexpected occurrence either resulting in, or having the likely potential to result in death, serious injury (or illness) requiring hospitalization and environmental impact posing a serious threat to on-scene personnel or wildlife, or major and significant damage to Operator or Contractor property. The response to such incidents requires immediate notification and action.

#### 1.5 Primary Objective of the Emergency Response Plan

The primary objective of the ERP is to address the provision of support during emergencies which result in, or may result in:

- Direct threat to human life.
- Potential or actual damage to facilities or major equipment, sabotage, terrorism and / or other criminal acts.
- Potential or actual uncontrolled exposure of hazardous / contaminant materials to the environment.

In the event of an onshore or offshore emergency the ERP also provides procedures to ensure a Local Emergency Operations Centre (LEOC) is established as soon as possible after the occurrence of an emergency and that all necessary support (technical, media, family, regulatory liaison, logistics, etc.) is provided to the facility or location experiencing the emergency.

As a matter of policy, NWest Energy Limited will make a copy of the ERP available to each person and / or organization involved in the emergency response and / or emergency management process.

#### 1.6 Related and / or Specific Emergency Response Documents

Other documentation related to the ERP includes the:

- (a) “VESSEL” Emergency Preparedness Manual.
- (b) “VESSEL” Shipboard Oil Pollution Emergency Plan.

#### 1.7 Command Authority – Offshore Person in Command - “VESSEL”

The “VESSEL” Captain shall be responsible for all matters related to safety, health, personnel welfare and the environment. In any emergency situation the CAPTAIN has complete authority to operate in a manner that he regards as the best response for the safety of personnel, the

installation and the environment.

**1.8 Command Authority – Onshore Project Manager**

NWest Energy Limited’s Exploration Project Manager (Incident Commander) has decision making authority in relation to the provision of support to the CAPTAIN on board the “VESSEL”.

**1.10 Geographical Areas and Facilities Covered by the ERP**

The facilities at which emergencies may occur that may involve personnel or assets related to NWest Energy Limited include:

Offshore	Onshore
“Vessel” Chase or supply boats	West Coast Shore Base NWest Office Contractor’s Office
Helicopter, Cougar Helicopters	

**1.11 Supply and Chase Vessels**

A supply and/or chase vessel will remain in the vicinity of the “VESSEL” during most of the program. Under adverse weather conditions, discussions between the respective vessel captains will coordinate safe and acceptable distances between vessels. In such cases, the reasons for this approval should be logged.

**1.12 Standby Helicopter**

A standby helicopter available for search and rescue (SAR) will be available for the Project.

**1.17 ERP Exercises**

The ERP will be tested prior to the start of operations and again when the vessel is close to the survey area so that communication lines with the Vessel are verified.

**2.0 EMERGENCY ORGANIZATION AND COMMUNICATIONS**

**2.1 Introduction**

In any offshore emergency, the most critical tasks are those performed as part of the initial response. The “VESSEL” has a well prepared Emergency Preparedness Manual (EPM) that clearly describes the roles and responsibilities of those personnel working on board as they may relate to the various types of emergencies that may occur on board. Complimenting the “VESSEL”’s Emergency Response Teams are members of NWest’s Local Emergency Operations Centre (LEOC) in St. John’s. Members of the LEOC will be on-call 24/7 for the duration of operations. ERP members will provide support and communication functions, not only related to the “VESSEL”, but also to other onshore support groups and / or agencies who provide emergency response services and / or support.

**2.2 Emergency Management Structure Overview**

It is recognized that offshore personnel are trained and certified to CNLOPB (or equivalent) standards. For this reason initial responders working from within NWest’s LEOC in St. John’s must be capable of providing support to the CAPTAIN based upon his expectations.

As a corporation, NWest Energy utilises the Incident Command System (ICS). As the INITIAL RESPONSE (normally less than 6 hours) to an offshore emergency requires immediate and focused action in specific areas, primarily those related to the saving of life, members of the LEOC will provide initial support based upon an Offshore Emergency Management System (OEMS) that is compatible with the immediate and critical requirements of the CAPTAIN. This approach is standard practice among all East Coast Operators and is a proven method of providing critical response services when time is critical.

However, it is also recognized that as an offshore emergency progresses from short-term issues (e.g.: evacuating personnel to shore, putting out onboard fires, rescuing personnel from the “VESSEL” or ocean, etc.) to long-term issues (cleanup, salvage, etc.) a transition must be made to the ICS system. Therefore, personnel working within NWest’s LEOC will, in the event of a long term incident, be replaced by other NWest Energy personnel as per the typical ICS structure. For that reason, key personnel within NWest’s LEOC have been given specific ICS titles, where applicable.

### **2.3 Local Emergency Operations Centre (LEOC) Location**

In the event of an emergency, onshore response support is handled through NWest’s LEOC located on the 8<sup>th</sup> floor of Baine Johnston Center, St. John’s, Newfoundland and Labrador. The purpose of the LEOC is to provide support to on-scene emergency responders and to aid in bringing the emergency under control. Support may include:

- (a) Assisting the on-scene emergency team by obtaining personnel and equipment resources, as required.
- (b) Liaising with government and regulatory authorities, Non-Government Organizations (NGOs) and addressing engineering, logistics, procurement, family, media, financial and safety issues on behalf of the facility experiencing the emergency.

### **2.4 Contractors Representative to Form Part of NWest’s LEOC**

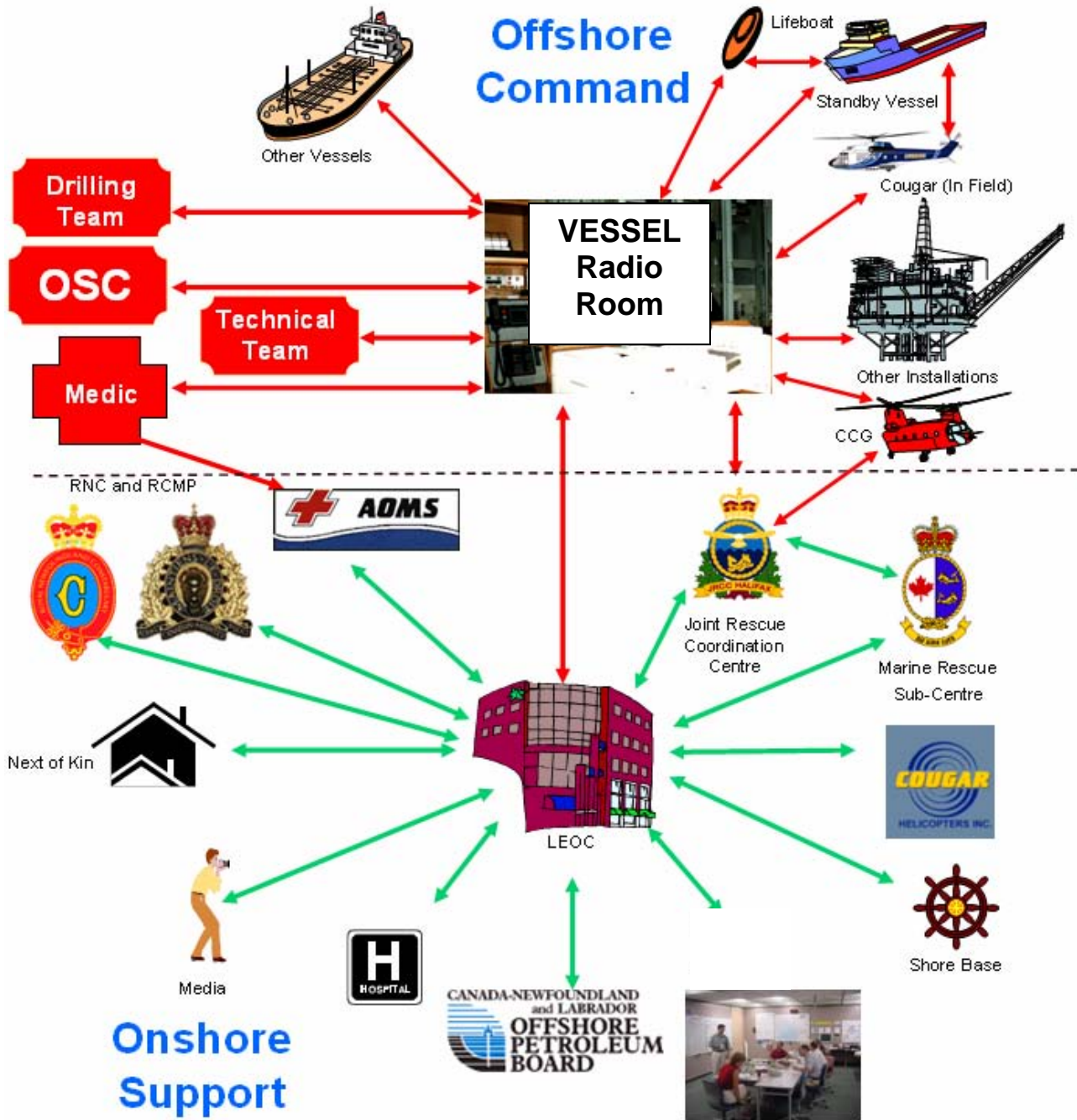
The “Contractor” Area Manager forms an integral part of NWest’s LEOC and will be the dedicated link between the LEOC onshore and the CAPTAIN within the Emergency Control Centre (ECC) offshore. The Area Manager shall have onshore authority for decision making on behalf of “Contractor”.

### **2.6 LEOC Call-Out Protocol (From “VESSEL” or Other Location)**

During an “Alert” or an “Emergency” related to the “VESSEL”, the CAPTAIN will be responsible for notifying his shore based supervisor - the Contractor Area Manager and / or mobilizing the LEOC. For onshore incidents, the person discovering an emergency assumes the responsibility for notifying the NWest Project Manager and / or mobilizing the LEOC.

### 2.9 Communications Diagram (All Responders)

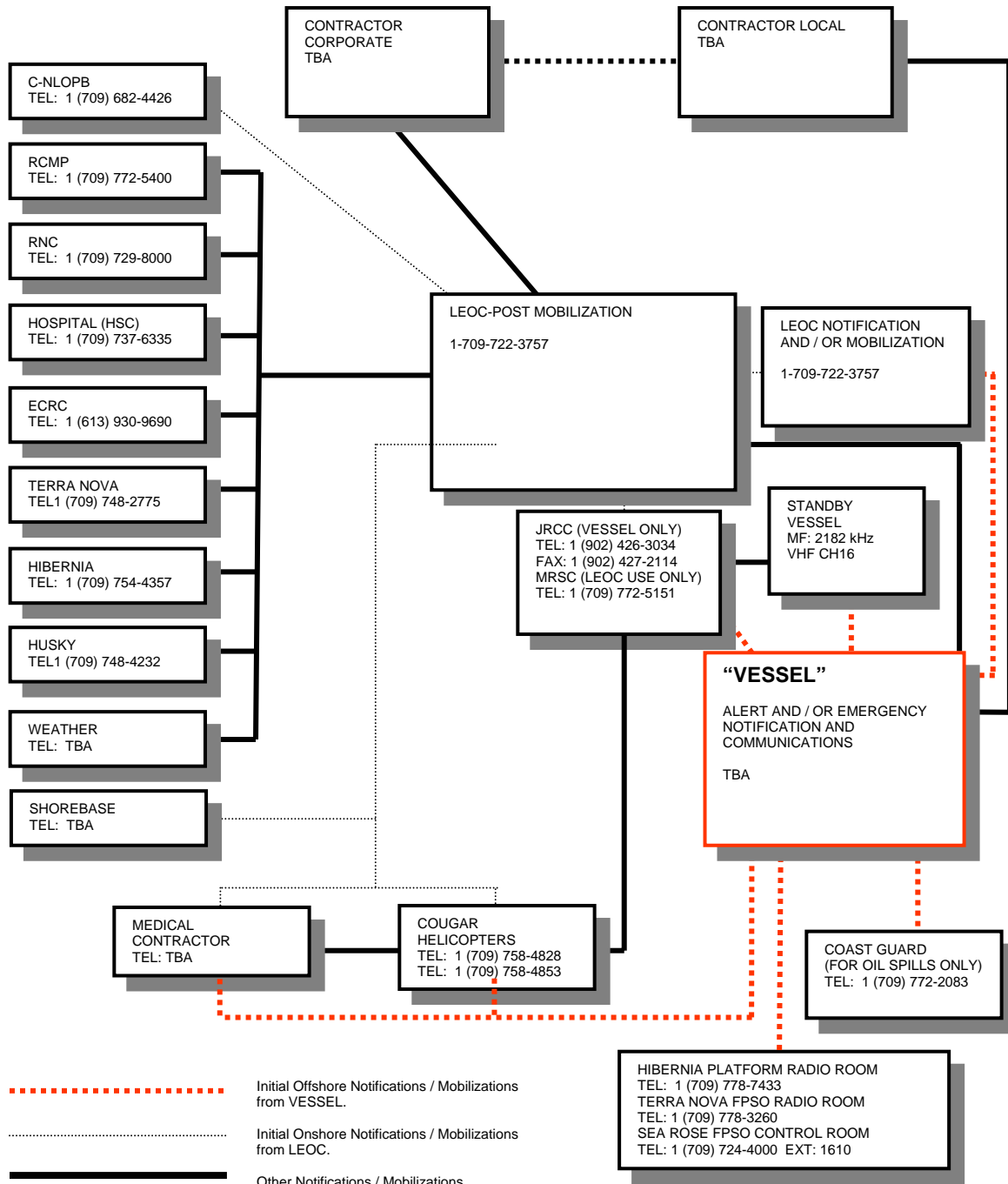
As an aid to communications, the following diagram demonstrates the extent of emergency management communications and will also serve as a guide for users of this ERP.



From: Offshore Emergency Management System – 1998, Seacom International Inc.

**2.10 Notification Flowchart (All Responders)**

During an Emergency the responders can refer to the Notification Flowchart for key notification and mobilization numbers and should be clearly displayed in the CAPTAIN’s office, ECC, Radio Room, Project Managers Office, Exploration Superintendent’s Office and LEOC.



### **2.11 Police Jurisdiction (RNC)**

The Royal Newfoundland Constabulary (RNC) is a provincial police force responsible for providing policing service to three areas of Newfoundland and Labrador. These are:

- St. John's
- Mount Pearl
- North East Avalon
- Corner Brook
- Labrador West

### **2.12 Tactical Support (RNC)**

Within their jurisdiction, the RNC's Tactical Rescue Unit (TRU) can respond to any serious calls such as hostage takings, barricaded persons, suicidal persons, armed robberies, and any other task that is given to them within the RNC's jurisdiction, including Corner Brook and Labrador. The RNC can also assist with crowd control at key onshore facilities. These can include, offices, Shorebases, etc.

### **2.13 Police Jurisdiction (RCMP) / Suspension of Operations After an Incident**

The Royal Canadian Mounted Police (RCMP) have jurisdiction in Federal waters (including the VESSEL) and onshore in all of Newfoundland and Labrador except in the surrounding communities which comprise the North East Avalon; Corner Brook and Labrador West.

### **2.14 Tactical Support (RCMP) – “VESSEL” Incident**

Within their jurisdiction, the RCMP can respond to any serious calls such as hostage takings, barricaded persons, suicidal persons, armed robberies, and any other task that is given to them within the RCMP's jurisdiction.

In offshore situations which are accidental in nature the RCMP would be acting as an agent of the Chief Medical Examiner for the Province of Newfoundland and Labrador. Upon receipt of a call reporting an incident of the above nature, the RCMP would request NWest Energy provide transportation to the “VESSEL” (provided this action did not interfere with evacuation, lifesaving, etc.). The RCMP would also request minimal disposition of bodies, body parts and wreckage. At the first opportunity to travel to the “VESSEL”, an RCMP contingent (numbers depending on the situation), and likely a medical examiner would fly to the “VESSEL” and commence the investigation.

If prior to or during the investigation there is a reason to believe a breach of the Criminal Code of Canada or other statute exists, the responsibility for the investigation then belongs to the RCMP directly. The Chief Medical Examiner must still fulfill his mandate as indicated and in addition will act as a resource person to the RCMP. If the incident occurred as the result of criminal action or negligence, the RCMP will seek to gather evidence to that end. This will involve the seizure of evidence and interviews with witnesses at the scene. If no criminal indication is found the evidence gathered may be retained should a public inquiry be held into the death(s) or an inquiry into the disaster to determine its cause and make recommendations to avert further occurrence.

### **2.15 Bomb Threats / Bomb Detonation (RCMP)**

Bomb threats can be of several varieties and usually classified as specific and non-specific in nature. Specific as to location, detonation time, etc., and nonspecific usually consisting of a simple statement with very little detail.

The purpose of the RCMP deployment here would be to assist Facility personnel with theft operational plan to locate the bomb/device, or in the event the bomb/device is found, to deal with its disposal. The RCMP has explosives detection police dog and handler stationed at Gander, Newfoundland.

If a bomb threat against the “VESSEL” is received, the RCMP will respond and assist in the search of the “VESSEL” for the bomb/device. The RCMP would request transportation to the “VESSEL” for 24 personnel and possibly a police dog. This response would take place whether the bomb threat is specific or non-specific.

If there is a detonation of the suspect bomb/device, the RCMP would respond in a manner similar to deployment outlined above, “Disaster Type Incident”. The responding personnel in this instance will be attempting to locate shrapnel and other trace evidence of the device.

Note: If a search is mounted by “VESSEL” personnel precise notes should be taken documenting the areas searched and the location of any suspicious items.

**2.16 Terrorism and Hostage Taking (RCMP)**

This section includes:

- (a) Hostage taking.
- (b) Barricaded person(s).
- (c) Ongoing emergency involving deranged person.
- (d) Assault on “VESSEL” by outside group or agency (terrorists).

These situations involve a present threat to the “VESSEL” and its personnel and thus the purpose of the RCMP response will be to preserve life and to neutralize the perpetrator(s) / deranged person using only as much force as is necessary in the circumstances. The RCMP will respond with an appropriate contingent of personnel to address the specific situation and will request transportation by NWest Energy to the “VESSEL”. This could involve up to 12 (twelve) personnel and equipment. Certain situations may prevent landing on the “VESSEL”, i.e. weapons, fire. etc., and thus deployment to a ship or other rig in the vicinity might be considered if such options were available.

**2.17 Notification of Accidents and Emergencies (RCMP / RNC)**

The RNC or RCMP must be notified of all accidents or emergencies resulting in fatalities or serious injuries within their jurisdiction. The following table may assist in determining if notification to the RCMP and / or RNC is required (if in doubt, make the call):

RCMP “VESSEL” / Offshore Incident	RNC Onshore Incident
Federal waters and in all of Newfoundland and Labrador except in the surrounding communities of the North East Avalon; Corner Brook and Labrador West.	St. John’s, Mount Pearl and the surrounding communities which comprise the North East Avalon; Corner Brook; and Labrador West
Serious Accident	Serious Accident
Serious Injury	Serious Injury
Death	Death
Terrorism	Terrorism
Bomb Threat	Bomb Threat
Barricaded Person	Barricaded Person
Suicidal Person	Suicidal Person
Armed Robberies	Armed Robberies
Other Crimes	Other Crimes

**2.18 Family & Next of Kin Notification (RCMP / RNC)**

While Police (RCMP /RNC) may assist in notifications of serious injuries and death, NWest Energy remains responsible for the notification of next of kin for NWest Energy Employees.



Contractors with personnel working at NWest Energy facilities will be responsible for making family notifications to their own employees. Contractor HR representatives will be notified by the NWest if their personnel are involved in the incident.

It therefore follows that close liaison between the Police and NWest Energy is necessary during the critical phase of notifying families and next of kin.

## 2.19 Suspension of Operations

When an incident occurs that results in a serious illness or injury, including the permanent impairment or loss of a body part or death, all operations associated with the incident shall be suspended until resumption has been authorized by an official of the C-NLOPB, the RCMP, or other recognized authority. In addition, the scene of the incident, including the equipment used in any lifesaving attempts, shall be preserved with the following exceptions.

- (a) To immediately attend to persons injured or killed.
- (b) To immediately prevent further injuries.
- (c) To immediately protect the property that is endangered because of the incident, or
- (d) As directed by an official of the C-NLOPB, the RCMP, or other recognized authority.

## 3.0 ALERT CRITERIA / EMERGENCY LEVEL

### 3.1 Declaring an Alert and Emergency

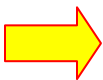
The decision to declare an “Alert” or “Emergency” is risk-based depending on the situation at the time and is typically dependent on the professional judgement of the CAPTAIN.

An “Alert” will be declared when any condition exists or is forecast which does not require immediate response but has the likely potential to escalate into a defined emergency situation adversely affecting the safety of the “VESSEL” or support craft if not addressed.

Accordingly, the following criteria is to be utilized when a decision is required related to making a notification of an “Alert” or “Emergency”.

**AUTHORITY:** “VESSEL” CAPTAIN. CAPTAIN MAY CONSULT WITH OTHER SENIOR ONSHORE OR OFFSHORE PERSONNEL.

### 3.2 Alert / Emergency Notification to the JRCC / MRSC



When an “ALERT” or “EMERGENCY” situation occurs, the “VESSEL” CAPTAIN is to ensure that he, or a nominated representative, notifies the JRCC / MRSC immediately.

**PRIMARY NUMBER FOR THE “VESSEL” DURING EMERGENCIES  
(BOTH JRCC AND MRSC WILL ANSWER THE CALL)**

**1 (902) 426-3034**

To facilitate notification, JRCC Halifax and MRSC St. John’s have established Oil & Gas Emergency lines. These telephone lines are dedicated numbers specifically for offshore operators to contact JRCC Halifax or MRSC St. John’s regarding alerts, offshore emergencies and drills. The system has been tested, is stable, and allows multiple users to call in at the same time. All emergency numbers are active and can be utilized if required. When calling either the JRCC or MRSC, the caller will note that both the JRCC and MRSC will answer the call, irrespective of who is called. In essence a 3 way conversation will take place between the caller,

Other JRCC / MRSC Emergency contact numbers are:

<b>OTHER JRCC HALIFAX EMERGENCY NUMBERS:</b>		<b>OTHER MRSC, ST. JOHN'S EMERGENCY NUMBERS:</b>	
Tel:	1 (902) 427-8200	<b>Tel: For LEOC Use</b>	<b>1 (709) 772-5151</b>
Tel:	1 (800) 565-1582	Tel:	1 (800) 563-2444
Fax:	1 (902) 427-2114	Fax:	1 (709) 772-2597

## **Gear Conflict Procedures During Marine Seismic Operations**

### **Recording / Reporting Procedures for Fishing Gear & Vessel Loss and Damage Incidents**

#### **Recording Incident Information**

If you have any indication that the vessel or the seismic streamer may have made contact with fishing gear (e.g. ropes or other debris caught on the streamer or acoustic array), you should, as soon as feasible:

1. take all reasonable action to prevent any further or continuing damage
2. note how the incident was discovered and by whom
3. note exact time, location, sea conditions, and any other pertinent information about the discovery of the event
4. record any fisher/fishing vessel identification number (e.g. a Canadian Fishing Vessel/CFV number painted on a buoy, or a crab pot licence tag)
5. if possible, photograph the gear debris in the water and after recovery
6. secure and retain any of the suspected gear debris, if this is possible and feasible
7. note what the seismic vessel had been doing before discovering the incident, and retain any data on the ship's positions during the preceding 24 hours
8. note any other vessels that you are aware of in your vicinity before/during discovering the incident.

The Damage Report form that would be filed by a fisher in order to make a claim for damages is attached. You may also fill in any of the additional information indicated on this form if you feel it is relevant.

#### **Reporting an Incident**

1. As soon as possible after an incident (or a suspected incident) has occurred notify the Client's representative on board the seismic vessel as soon as possible after an incident, notify NWest Energy Inc. by phone at

Blair MacDougall  
Tel: 709-722-3757  
Fax: 709-722-3787  
E-mail: [bmacdougall@nwestenergy.com](mailto:bmacdougall@nwestenergy.com)

2. Notify Kim Coady at the C-NLOPB, directly from the seismic vessel, via E-mail at [kcoady@cnlopb.nf.ca](mailto:kcoady@cnlopb.nf.ca). As soon as possible after an incident, e-mail

[bmacdougall@nwestenergy.com](mailto:bmacdougall@nwestenergy.com) the information specified in Items 3 and 4, and if possible a copy of any digital photographs taken.

3. If possible, retain any gear debris until it can be transported to shore.

### **Sighting or Moving Fixed Fishing Gear**

If the seismic vessel sights any evidence of fixed fishing gear (e.g. "highflyer" with radar reflector affixed to a large buoy; three buoys together) which the vessel believes may be located on or close to one of the survey lines, the following procedure is recommended.

1. If possible, the seismic vessel should observe and record any identification:
  - number (e.g. the CFV number) painted on the buoy or highflyer.
  - The seismic vessel should attempt to hail (via VHF radio) any fishing vessels which may be in the vicinity.
  - If a fishing vessel can be reached, report the type, location and, if known, the CFV numbers marked on the gear and ask the skipper of that vessel for any information which might allow the seismic vessel to identify the owner.  
(Note: It is not legal for any one but the gear owner to move the gear.)
2. If the CFV number is known, identification of the gear owner may be possible. Contact the Fisheries Liason Officer to identify gear owner.
3. If it is not possible to contact the gear owner, the seismic vessel should attempt to survey a nearby line and return to the first location at a later time.

## **Damage Report Form for Survey Vessels**

1. Survey Vessel Name and Person completing Report:

Position

E-mail/Phone No: /

2.. Date of incident:

Time of incident/discovery: /

Location of the incident Lat: Long:  
(If known)

3. Name of fishing vessel:

CFV No (on gear/buoy):

Vessel Skipper/Owner:

Address:

Telephone/Fax No: /

4. Wind / weather / visibility / sea state at time of incident or discovery:

5. Describe the type and quantity gear recovered (including any identifying marks /numbers, etc):

6. Describe what the survey vessel was doing at the time of the incident:

7. Describe what the fishing vessel was doing at the time of the incident:

8. Draw a sketch/diagram showing the position of the survey vessel/gear in relation to the gear, fishing vessel, etc.:

9. Describe any measures the survey vessel took to recover gear, or to stop or limit the damage or loss:

10. Names of any other vessels in the area at the time of the incident (if known):

11. Describes steps taken to notify fishing vessel or others:

12. Other pertinent information / remarks (use extra sheets if necessary):