

Block pumps CB, CBL, CBF, CBFL

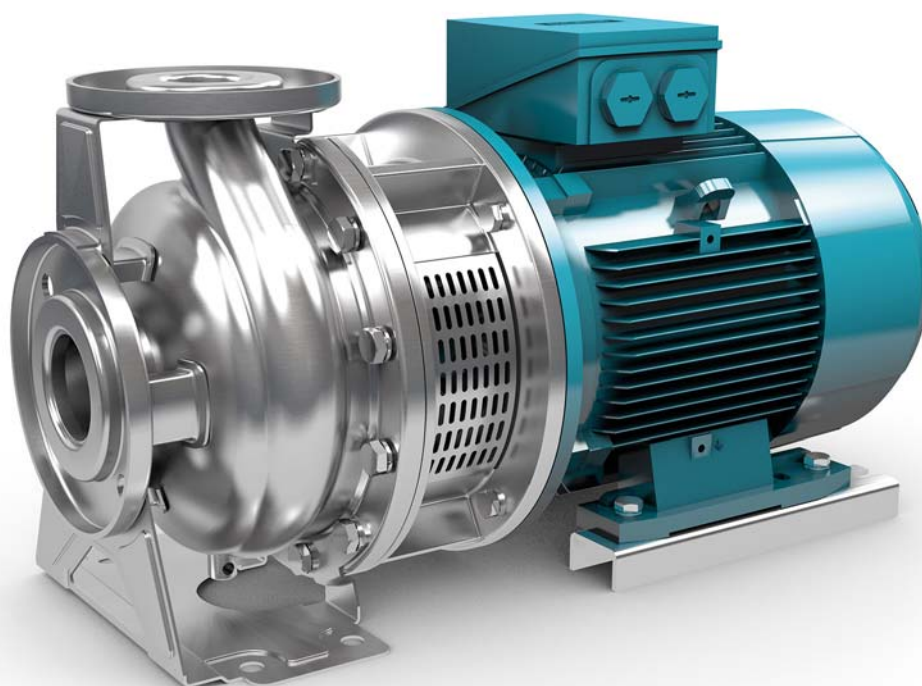

Operating instructions



**Translation of the original operating instructions
Please read and retain**



Service?
www.edur.com

© 2023 EDUR-Pumpenfabrik

Distribution and reproduction of this document as well as the exploitation and communication of its contents are prohibited unless expressly permitted. Any infringement shall give rise to an obligation to pay damages. All rights reserved.

Contents

1	Introduction	5
1.1	Addresses	5
1.2	Applicable documents	5
1.3	About these operating instructions	6
1.4	Signs on the pump	6
2	Safety	8
2.1	Reading the operating instructions	8
2.2	Proper use	9
2.3	Improper use	9
2.4	Basic safety instructions	9
2.5	Personal protective equipment	10
2.6	Protective devices	10
3	Technical data	11
3.1	Pump	11
3.2	Motor	11
3.3	Noise emissions	12
4	Design and function	13
4.1	Pump	13
4.2	Shaft seal	14
4.2.1	Mechanical seal with conical spring	14
4.2.2	Mechanical seal with elastomer bellows	14
5	Transport	15
5.1	Safety during transport with a crane	15
5.2	Transporting the pump with a crane	15
5.3	Transporting the pump with an industrial truck	16
6	Storage	16
6.1	Safety during storage	16
6.2	Removing preserving agents	16
6.3	Storing the pump	16
7	Installation	17
7.1	Safety during installation	17
7.2	Requirements for the installation site	18
7.3	Requirements for the pipe system	18
7.4	Permissible forces and torques	20
7.5	Requirements for the electrical connection	21
7.6	Sound insulation and compensators	22
7.7	Installing the pump	22

8	Removal	23
8.1	Safety during removal	23
8.2	Removing the pump	24
9	Operation	25
9.1	Safety during operation	25
9.2	Initial commissioning	26
9.3	Operation	26
9.4	Ending operation	27
10	Maintenance	27
10.1	Safety during maintenance	27
10.2	Maintenance schedule	28
10.3	Maintenance work	28
10.3.1	Tightening torques	28
10.3.2	Exchanging shaft bearings	29
10.3.3	Removing the shaft seal	30
10.3.4	Installing the shaft seal	31
10.3.4.1	Installing the mechanical seal with elastomer bellows and O-ring	32
10.3.4.2	Installing the mechanical seal with conical spring	33
10.3.5	Installing the casing	34
11	Faults	35
11.1	Safety during fault rectification	35
11.2	Fault table	36
12	Disposal	37
12.1	Safety during disposal	37
12.2	Disposing of the pump	38
12.3	Returning	38
13	Annex	39
13.1	Content of the declaration of conformity	39
13.2	Certificate of unobjectionability	39
	Index	41

1 Introduction

1.1 Addresses

Manufacturer

EDUR-Pumpenfabrik
Eduard Redlien GmbH & Co. KG
Edisonstraße 33
24145 Kiel
Germany

☎ +49 431 689868
✉ info@edur.de
🌐 www.edur.com

Delivery address for returns

EDUR-Pumpenfabrik
Eduard Redlien GmbH & Co. KG
Marie-Curie-Straße 15
24145 Kiel
Germany

1.2 Applicable documents

The overall documentation encompasses the following other applicable documents:

- Data sheet
- Hydraulic water characteristic curve
- Dimension sheet/installation plan
- Supplier documentation for assemblies from external suppliers
- Test certificates, if included in the scope of delivery of external suppliers and contractually agreed
- Acceptance test certificates, if contractually agreed
- Further documents, if contractually agreed.

1.3 About these operating instructions

In these operating instructions, safety information is contained in the 'Safety' chapters and in the warnings that can occur in all chapters.

The warnings are subdivided into hazard levels and are identified as follows:

WARNING

This warning indicates a possibly hazardous situation. Failure to observe this warning can result in death or severe physical injuries.

CAUTION

This warning indicates a possibly hazardous situation. Failure to observe this warning can result in moderate or slight physical injuries.

NOTICE

This warning constitutes a warning concerning property damage.

A pump assembly always consists of the pump and a motor. For simplification, the term **pump** is used in the operating instructions.

The pump is intended for installation in machines or systems. For simplification, the word **system** is used in the operating instructions.

1.4 Signs on the pump

The signs are part of the pump. They must not be removed, painted over or rendered illegible. Damaged, illegible or missing signs must be replaced.

Signs on the pump

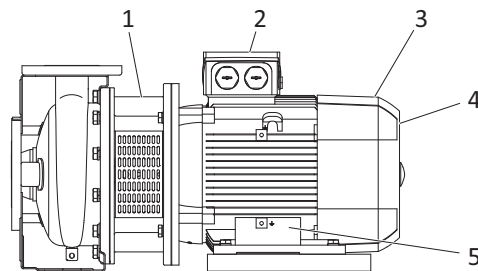

Fig. 1-1 Signs on the pump

Item	Sign	Explanation
1		Type plate for CBL and CBFL pumps , see Type plate on pump, page 7.
2		Read instructions Requests the personnel to read the instructions before working on the pump.
3		Type plate for CB and CBF pumps , see Type plate on pump, page 7.
4		Rotation direction The arrow indicates the specified direction of rotation of the pump.
5		Motor type plate , see Type plate on the motor, page 8.

Tab. 1-1 Explanations of signs

Type plate on pump

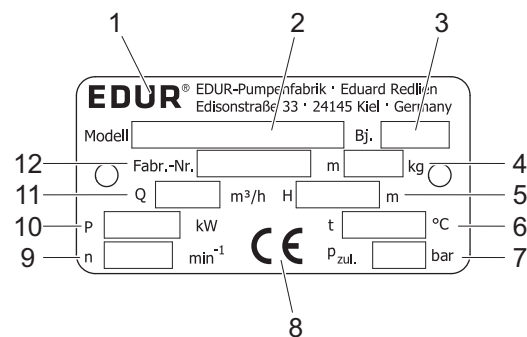

Fig. 1-2 Type plate on pump

- 1 Manufacturer
- 2 Model designation
- 3 Year of construction
- 4 Overall weight
- 5 Head
- 6 Maximum temperature of the pumped fluid
- 7 Maximum permissible pressure
- 8 CE symbol
- 9 Rated speed
- 10 Power consumption
- 11 Volumetric flow/delivery rate
- 12 Factory number/serial number

Type plate on the motor

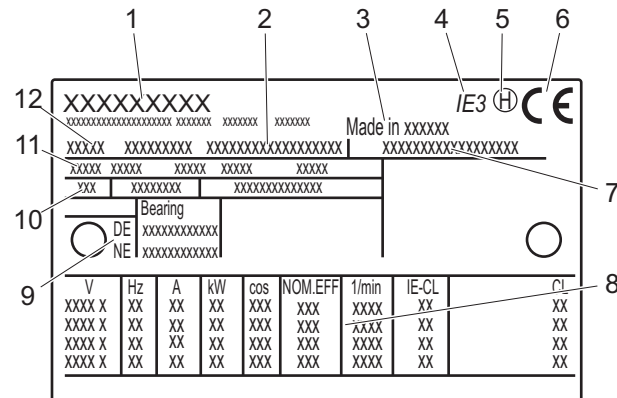

Fig. 1-3 Type plate on the motor

- 1 Manufacturer
- 2 Motor designation
- 3 Country of origin
- 4 Efficiency class
- 5 Balancing
- 6 CE symbol
- 7 Serial number with year of manufacture
- 8 Rated motor data
- 9 Storage
- 10 Weight | Insulation class | Temperature range
- 11 Standards | Size | Type | Protection class
- 12 Number of phases

The item numbers in the figure may deviate depending on the motor make.

2 Safety

2.1 Reading the operating instructions

The personnel that carries out work on the pump must have read and understood the operating instructions. The operating instructions must be available at the operating location and be retained throughout the entire service life of the pump.

The local, generally valid, statutory and other binding accident prevention and environmental protection regulations must be observed in addition to the operating instructions.

2.2 Proper use

The pump is intended for installation in machines and systems for pumping pure or slightly contaminated fluids.

Possible areas of use include cooling and refrigeration technology, climate technology, filtration, shipbuilding, plant engineering, energy technology, plastic processing, surface technology and general mechanical engineering.

Each pump is built for a specific customer. The materials and seals are selected for the respective pumped fluid and the operating area. The pump may only be operated with the approved pumped fluid and within the specified limits of the operating area, see Chapter 1.2 Applicable documents, page 5.

2.3 Improper use

The pump may only be operated in installed condition within a pipe network. Switching it on even temporarily outside of the pipe network is considered improper.

The pump must not be operated in an explosive environment.

2.4 Basic safety instructions

Installation and removal work, operation and maintenance may only be carried out by qualified specialist personnel. Qualified specialist personnel includes persons who are able to independently recognise and avoid possible hazards based on their training and experience. The owner must ensure these qualifications.

Observe all local, statutory and system-specific regulations and requirements.

Do not carry out any independent modifications or conversions. Modifications and conversions must be approved by the manufacturer.

Always operate the pump in the specified direction of rotation and with pumped fluid.

When pumping pumped fluids that pose a risk to health and the environment, observe the statutory and operational safety regulations. Avoid any risk of inhalation, swallowing or contact with eyes, skin and mucous membranes.

2.5 Personal protective equipment

The personal protective equipment depends on the operating location and the pumped fluid. The scope of the personal protective equipment must be defined by the owner.

The manufacturer recommends the following as the minimum requirement:

- Safety shoes
- Protective gloves
- Safety glasses (optional)
- Ear protectors (optional)

2.6 Protective devices

Pumps with a coupling can be equipped with a coupling guard depending on type.

The owner must install the following protective devices on all pumps:

- Facility for disconnecting the power supply in an emergency
- Motor protection/overload protection

The owner must install further protective devices depending on the type, the technical data and the installation location:

- Contact protection in the case of very hot or cold pumped fluids
- Soundproofing if the statutory specifications concerning noise emissions are exceeded
- Protection against weather and environmental influences

When pumping pumped fluids that pose a risk to health and the environment, the owner must implement corresponding safety measures, e.g. installing a collection facility.

The pump must only be operated with installed and functioning protective devices.

3 Technical data

The type plate and the applicable documents contain the technical data. The technical data specified here are generally valid and can deviate in individual cases.

3.1 Pump

Single-stage centrifugal pump in block design	
Permissible pressure	Max. 10 bar
Fluid temperature range	-20 °C to 110 °C
Viscosity – CB – CBF	≤ 115 mm ² s ⁻¹ ≤ 60 mm ² s ⁻¹
Shaft seal	Mechanical seal
Ambient temperature	-20 °C to 40 °C

Tab. 3-1 Pump technical data

3.2 Motor

IEC three-phase motor (self-cooled)	
Protection class	IP55
Insulation class	F (155°C)
Operating mode	S1 continuous operation
Ambient temperature (permissible coolant temperature)	-20 °C to 40 °C
Installation height above MSL	Max. 1000 m
Rotational speed	1,450 (1,750) rpm 2,900 (3,500) rpm
Frequency	50 (60) Hz

Tab. 3-2 Motor technical data

3.3 Noise emissions

Rated power requirement [kW]	Emission sound pressure level LpA [dB] at rotational speed	
	1,450 rpm	2,900 rpm
0.55	< 70	< 70
0.75		
1.1		
1.5		
2.2		
3.0		71
4.0		71
5.5		72
7.5		72
11.0	–	74
15.0	–	75
18.5	–	76
22.0	–	77
30.0	–	78
37.0	–	79
45.0	–	80

Tab. 3-3 Emission sound pressure level LpA

The emission sound pressure level actually determined on site may deviate significantly from the specified values due to the operating and installation conditions. The values have a measurement tolerance of ± 3 dB and cannot be guaranteed.

Increased noise emissions can occur due to cavitation, defective or worn bearings and due to vibrations. Observe installation and maintenance instructions, see Chapter 7 Installation, page 17 and Chapter 10 Maintenance, page 27.

4 Design and function

4.1 Pump

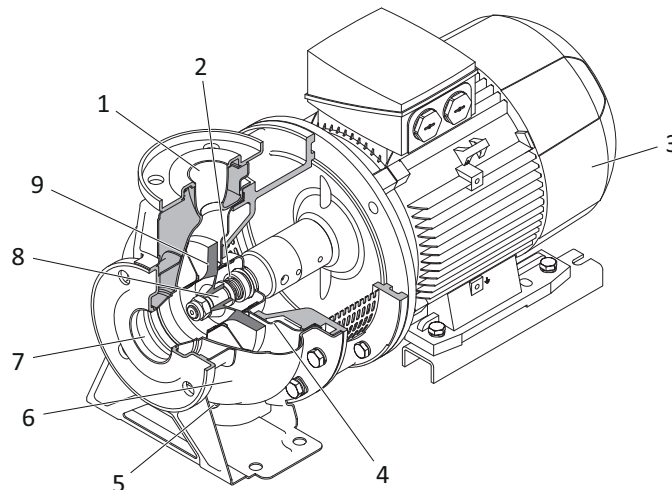

Fig. 4-1 Pump design

- 1 Pressure fitting
- 2 Shaft seal
- 3 Motor
- 4 Cover
- 5 Drain plug
- 6 Casing
- 7 Suction nozzle
- 8 Shaft
- 9 Impeller

Centrifugal pumps are used to pump incompressible media that are available in fluid form and may include gaseous or solid contents. Centrifugal pumps transfer energy from the pump to the pumped fluid through fluidic processes.

By means of an energy gradient, the pumped fluid flows via the suction nozzle into the pump, where it encounters the rotating impeller. The impeller is driven by the motor. The motor can drive the impeller directly via a shaft or via a stub shaft or a rigid flange coupling. The vanes of the impeller apply force onto the pumped fluid and increase its angular momentum. Energy is transferred to the pumped fluid and the pressure and absolute velocity increase. The energy content that is present in kinetic form in the increased absolute velocity is transformed into additional static pressure energy by means of a diffuser element. Guide vanes are used as the diffuser element. Together, the impeller and diffuser element are referred to as the pump's hydraulic system.

To maintain the flow, an energy gradient must also be present at the pressure nozzle. Losses in the system caused by friction or leakages increase the pump's power consumption.

The shaft seal prevents the pumped fluid from escaping at the rotating shaft. The drain plug is used to drain the pumped fluid.

The design of the casing depends on the specific type. If couplings are used, what are called lanterns are inserted between the motor and the cover.

The spare part drawing shows the detailed design of the pump. The spare part drawing can be downloaded in the service area of the EDUR homepage, www.edur.com.

4.2 Shaft seal

The shaft seal seals the rotating shaft from the pumped fluid.

4.2.1 Mechanical seal with conical spring

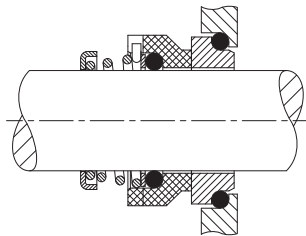

Fig. 4-2 Design of the mechanical seal with conical spring

Mechanical seals with conical spring use a round or profile ring as a dynamic sealing element and are dependent on the direction of rotation. Shaft rotations counter to the specified direction of rotation can damage or even destroy the mechanical seal.

4.2.2 Mechanical seal with elastomer bellows

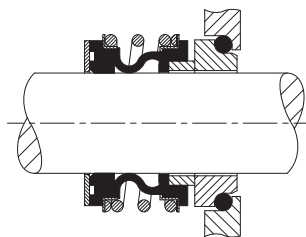

Fig. 4-3 Design of mechanical seal with elastomer bellows and O-ring

Mechanical seals with elastomer bellows use a bellows made of an elastomer as a dynamic sealing element and are not dependent on the direction of rotation.

Mechanical seals with elastomer bellows are a special type of mechanical seals.

5 Transport

The pump can be transported with an industrial truck or a crane.

5.1 Safety during transport with a crane

Improper transport can lead to personal injury and property damage. Observe the following safety instructions.

- Transport must only be carried out by qualified and trained personnel.
- Transport the pump in the horizontal position only.
- Use suitable lifting and lashing equipment. Observe the weight data on the type plate and the packaging.
- Do not use the ring bolts on the motor. The ring bolts on the motor are only designed for the weight of the motor.
- Do not remain beneath suspended loads.
- Make sure that nobody remains in the danger zone.
- Wear safety shoes.

5.2 Transporting the pump with a crane

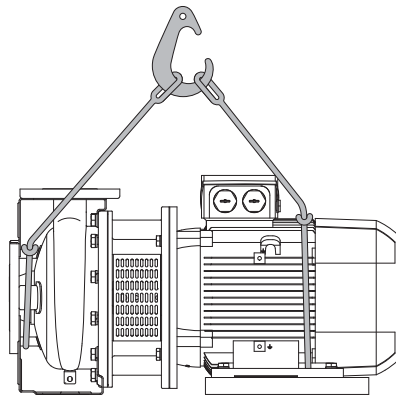

Fig. 5-1 Transporting the pump with a crane

1. Fasten lashing equipment to the pump, see figure.
2. Raise the pump carefully and transport it to the destination location.
3. Put the pump down carefully.
4. Remove the lashing equipment.

5.3 Transporting the pump with an industrial truck

The pump is secured on a pallet for shipping. After delivery, the pump can be transported on the pallet and with the packaging using a suitable industrial truck.

In the event of subsequent transport, the pump can again be placed onto a pallet and secured on it.

6 Storage

6.1 Safety during storage

Improper storage can lead to damage to the pump and to environmental pollution. Observe the following safety instructions.

Store the pump under the conditions specified here:

- The storage location must be covered, dry, well ventilated, frost-free and as vibration-free as possible.
- The humidity should be constant.
- Store the pump horizontally.
- Tightly seal the suction and pressure nozzles.
- Rotate the shaft by hand once a month, e.g. rotate the fan on the motor.
- If stored for more than two years, check the motor shaft bearings before installation and exchange them if necessary. If stored for more than four years, check the motor shaft bearings before installation and generally exchange them.

6.2 Removing preserving agents

Stainless steel pumps are not preserved.

6.3 Storing the pump

The pump must be prepared accordingly after removal and prior to renewed storage.

Stainless steel pumps can be stored without preservation.

⚠ WARNING**Risk of contamination when pumping pumped fluids that can be dangerous to health and the environment**

Pumped fluids that can be dangerous to health and the environment can chemically burn, poison or otherwise injure persons and damage the environment.

- Completely decontaminate the pump prior to storage.
-

NOTICE**Damage to the sealing elements**

Oils and greases can damage sealing elements with elastomers made of EP rubber.

- Avoid contact with oils and greases.
-

Prerequisite

- The pump has been removed, cleaned, is dry and has been decontaminated if necessary.
- The pump is in a horizontal position.

Procedure

1. Firmly screw in the venting screw(s) and drain screw(s).
2. Tightly seal the suction and pressure nozzles.

7 Installation

7.1 Safety during installation

Improper installation can lead to personal injury and property damage. Observe the following safety instructions.

- Installation must only be carried out by qualified and trained personnel.
- Observe the requirements for the installation location, see Chapter 7.2 Requirements for the installation site, page 18.
- Carry out installation in voltage-free condition.
- Observe the direction of flow.
- Secure the pipes and pump to prevent stumbling, and provide a safety area if necessary.
- Pay attention to noise emissions and fit soundproofing if necessary.

Observe the approved installation position, see figure. Any other installation position requires the approval of the manufacturer. Improper installation results in the risk of leaks at the feed lines and the risk of tearing off the pipe.

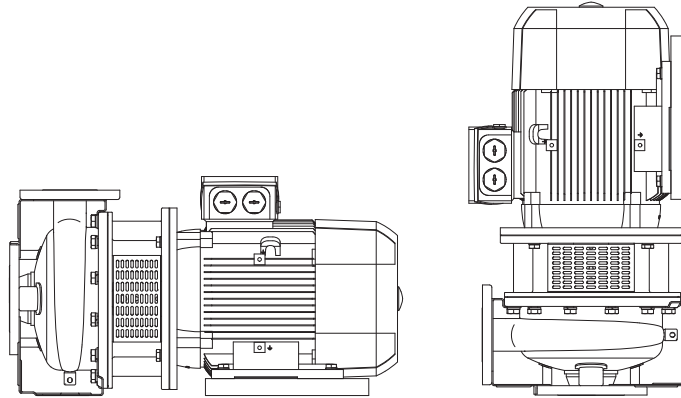

Fig. 7-1 Approved installation position

7.2 Requirements for the installation site

The installation location must meet the following requirements:

- The atmosphere must not be explosive.
- The installation location should be dust-free and not corrosive.
- The foundation must be horizontal, flat, adequately dimensioned for the weight of the pump and sufficiently strong.
- The pump must be freely accessible for monitoring, servicing, maintenance, installation and removal.
- A sufficient air supply must be ensured for cooling the motor. The motor fan must not be blocked. Impermissible heating can cause damage to the motor.
- The pump must be protected against environment influences such as wind, rain, frost or sand.

7.3 Requirements for the pipe system

The criteria listed in the following must be observed when designing the pipe system to ensure trouble-free and efficient pump operation:

- Route pressure and suction lines as per the respectively valid regulations and the relevant accident prevention regulations.
- Do not place strain on the pump due to the weight of the pipes.
- Never use the pump as a point for fixing the pipes.
- The pipe system must not cause any forces or torques (torsion, thermal expansion) to act on the pump that are higher than the permissible forces and torques, see Chapter 7.4 Permissible forces and torques, page 20.

- Provide suitable compensators to reduce the stresses that occur due to temperature fluctuations and vibrations.
- Provide slide gate valves close to the pump in the pressure and suction lines for maintenance work.
- Provide a non-return valve to avoid reverse flows.
- Providing a foot valve in the suction line for self-priming pumps during suction mode is recommended to prevent the pump and suction line from running empty during standstill.
- Use a suction strainer or filter to keep impurities in the pumped fluid away from the pump. No air from the fluid level or swirled-up dirt from the 'sump' may enter the suction line via the suction strainer in this case. Regularly clean the suction strainer and filter.
- Dimension the rated pipe widths comparatively large. Using rated widths that correspond at least to those of the pump connections is recommended.
- Design fittings so that they constrict the full pipe cross-section as little as possible.
- Always design the suction line as short and straight as possible in order to minimise pressure losses and achieve a high $NPSH_A$.
- Route the suction line without raised points in order to avoid gas accumulations.
- Position unavoidable pipe bends on one level only in order to avoid extensive pipe flow turbulence.
- Wherever possible, design cross-section extensions with an extension angle of $< 8^\circ$ to minimise pressure losses and prevent flow separation.
- Provide a straight pipe section with a length that is five times the inner diameter of the suction flange as a settling section between the suction flange and upstream fittings, cross-section changes or pipe deflections in order to avoid additional pressure losses and cavitation in the event of flow onto the pump impeller. Shorter settling sections are possible but can affect the hydraulic performance of the pump and/or lead to cavitation.
- Route the suction line to the pump with a descent of at least 10° for admission mode, and an ascent of at least 10° for suction mode, to avoid air pocket formation.
- Guarantee that the fluid level in the suction vessel is located a vertical distance of at least four times the inner diameter of the suction line above the inlet into the suction line in order to avoid air-sucking surface vortices.

- Round the transition from the suction vessel to the suction line or provide it with a chamfer to avoid cavitation in the pump inlet. This particularly applies in the case of pumped fluids that are close to or in boiling state.
- In the case of a pumped fluid that is close to or in boiling state, first route the suction line downstream of the suction vessel downwards over the longest possible section in order to prevent pumped fluid degassing.

7.4 Permissible forces and torques

The force and torque data apply to static pipe loads. For pump models without a pump foot, the permissible forces and torques in the following table must be reduced by 50%.

i Information

Forces and torques for materials that are not listed will be provided on request.

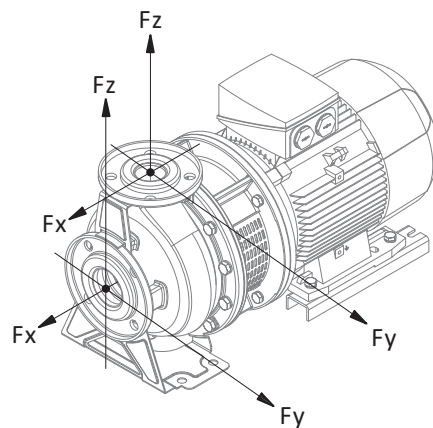

Fig. 7-2 Permissible forces and torques

Forces and torques for stainless steel sheeting

Model	Suction nozzle						Pressure fitting					
	DN	F _y [N]	F _z [N]	F _x [N]	ΣF* [N]	ΣM* [Nm]	DN	F _y [N]	F _z [N]	F _x [N]	ΣF* [N]	ΣM* [Nm]
CB(L) CBF(L)												
32	50	300	270	330	520	410	32	170	210	180	330	320
40	65	370	340	420	660	440	40	200	250	220	390	380
50	65	370	340	420	660	440	50	270	330	300	520	410
65	80	450	410	500	790	470	65	340	420	370	660	440

*ΣF and ΣM are vector sums of the forces and torques

Tab. 7-1 Forces and torques for stainless steel sheeting

Forces and torques for stainless steel casting

Model	Suction nozzle						Pressure fitting					
CB(L) CBF(L)	DN	Fy [N]	Fz [N]	Fx [N]	ΣF^* [N]	ΣM^* [Nm]	DN	Fy [N]	Fz [N]	Fx [N]	ΣF^* [N]	ΣM^* [Nm]
65	80	1575	1435	1750	2765	1645	65	1190	1470	1295	2310	1540
80	65	2100	1870	2345	3675	1820	80	1435	1750	1575	2765	1645

* ΣF and ΣM are vector sums of the forces and torques

Tab. 7-2 Forces and torques for stainless steel casting

7.5 Requirements for the electrical connection

The following requirements must be observed when connecting the motor:

- To protect the pump and the motor, always install overload protection, e.g. a motor circuit breaker. Operation without overload protection is impermissible.
- Observe the connection values and circuit type on the motor type plate. The specified voltage must not be exceeded.
- Earth the pipes and pump.

i Information

The power must be reduced as specified by the motor supplier if the pump is operated at ambient temperatures over 40°C or at installation heights over 1000 m (above MSL).

Tightening torques for terminal board connections on the motor

Thread	Tightening torque [Nm]
M4	0.8 to 1.2
M5	1.8 to 2.5
M6	2.7 to 4.0
M8	5.5 to 8.0
M10	9.0 to 13.0
M12	14.0 to 20.0
M16	27.0 to 40.0

Tab. 7-3 Tightening torques depending on the thread

7.6 Sound insulation and compensators

Pumps can cause increased noise emissions. Insulating the foundation and/or installing compensators, for example, is recommended to minimise noise but also to prevent vibrations and to compensate for thermal expansion.

NOTICE

Damaged compensators

Damaged compensators can crack and lead to damage to the system.

- Check compensators for embrittlement and cracks at regular intervals, and arrange for their exchange if necessary.

Recommended measures for noise minimisation:

- Insulation of the floor foundation by means of a suitable insulating plate **(3)**. The foundation must not be firmly connected to the floor or the walls.
- Installation of suitable compensators **(1)** between the pipe and pump.
- Use of vibration dampers **(2)**. In this case, a frame beneath the pump foot is required.

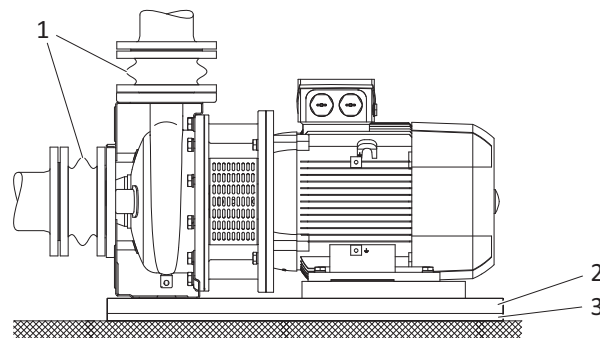

Fig. 7-3 Noise minimisation

7.7 Installing the pump

⚠ WARNING

Weight of the pump

There is a risk of crushing and abrasions during installation.

- Note the weight of the pump.
- Transport the pump using suitable lifting equipment.
- Wear protective gloves and safety shoes.
- Secure pumps that are installed vertically to prevent them from tipping during installation.

NOTICE

Checking the direction of rotation without pumped fluid

Operation without a pumped fluid is impermissible. Dry running for even a short time to check the direction of rotation can damage the mechanical seal.

- Fill and ventilate the pump before checking the direction of rotation.
-

Prerequisite

- Flange covers have been removed.
- The system is voltage-free and secured to prevent reactivation.
- There are no foreign objects in the pump.

Procedure

1. Position the pump at the installation location.
2. Align the pump.
3. If installed horizontally, bolt the foot to the foundation.
4. Connect pipes.
5. Connect the motor according to the wiring diagram.
6. Protect cable glands to prevent dust and moisture from entering.
7. Fill and ventilate the pump.
8. Check the direction of rotation.

Briefly switch on the motor and immediately switch it off again. Monitor the direction of rotation of the fan impeller. The direction of rotation must correspond to the direction of rotation arrow. If the direction of rotation on the motor is incorrect, check the electrical connection and also check the switch-gear if necessary.

8 Removal

8.1 Safety during removal

Improper removal can lead to personal injury and property damage. Observe the following safety instructions.

- Removal must only be carried out by qualified and trained personnel.
- Carry out removal in voltage-free and unpressurised condition.
- Observe the statutory regulations when pumping pumped fluids that can be dangerous to health and the environment.
- Carry out removal carefully. Do not use force.

8.2 Removing the pump

⚠ WARNING**Weight of the pump**

There is a risk of crushing and abrasions during removal.

- Note the weight of the pump.
 - Transport the pump using suitable lifting equipment.
 - Wear protective gloves and safety shoes.
 - Secure the pump to prevent it from tipping during removal.
-

⚠ WARNING**Risk of contamination when pumping pumped fluids that can be dangerous to health and the environment**

Pumped fluids that can be dangerous to health and the environment can chemically burn, poison or otherwise injure persons and damage the environment.

- Avoid direct contact with the pumped fluid.
 - Wear personal protective equipment. If necessary, wear a protective mask.
 - Collect escaping pumped fluid and dispose of it properly.
 - Decontaminate and flush the pipe system and pump.
-

Prerequisite

- The system/pump is switched off and depressurised.
- The pipe system and pump have been flushed and decontaminated if necessary.
- The pump is at ambient temperature.

Procedure

1. Close the slide gate valves in the pressure and suction lines.
 2. Switch off the pump's voltage and secure it to prevent reactivation.
 3. Disconnect the electrical connections and secure the cable ends.
 4. Remove the earthing from the pump.
 5. Place a collection container for collecting the pumped fluid or the flushing fluid beneath the pump.
 6. Unscrew the drain screw.
 7. Unscrew the venting screw.
 8. Drain the pumped fluid or flushing fluid into the collection container.
 9. Screw in the drain and venting screws.
 10. Release the pressure-side flange connection.
 11. Release the suction-side flange connection.
-

12. If present, release the fasteners on the foundation.
13. Lift the pump with the motor out from the pipe system.
14. Place the pump down on a horizontal, firm surface and secure it to prevent tipping.

9 Operation

9.1 Safety during operation

- Only operate the pump in flawless condition. Immediately shut off the system and secure it to prevent reactivation in the event of damage, leaks, overheating, unusual vibrations and noises.
- Only operate the pump within the pipe system.
- Only operate the pump when all safety devices are installed and functional.
- The pump can become extensively heated due to pumping hot pumped fluids. Do not touch the pump during operation. Wear protective gloves when working in the vicinity of the pump.
- The pump's noise emissions can exceed the statutory limit values. Wear ear protectors when remaining in the vicinity of the running pump.
- Exceeding the permissible pressure and temperature range can lead to leaks and cause the pump to burst. Adhere to the pump's pressure and temperature range, see type plate and chapter 1.2 Applicable documents, page 5.
- In the event of a fire, a hot pump can burst due to the use of cold extinguishing agent. Do not unnecessarily cool the pump excessively when extinguishing.
- Damage to or destruction of direction of rotation-dependent shaft seals if the pump is operated with the incorrect direction of rotation. Operate the pump in the specified direction of rotation.
- Damage to the shaft seal if the pump is operated without pumped fluid. Fill and ventilate the pump before commissioning it.
- Damage to or destruction of direction of rotation-dependent shaft seals if reverse flows rotate the impeller counter to the specified direction of rotation. Prevent reverse flows.

9.2 Initial commissioning

Prerequisite

- The pipe system and pump have been flushed.

Procedure

1. Fill the suction line and pump with pumped fluid. Ventilate the suction line and pump.
2. Completely open the slide gate valve on the suction line.
3. Completely close the slide gate valve in the pressure line.
4. Switch on the motor.

The pump now pumps against the closed slide gate valve in the pressure line.

5. Immediately after reaching the operating speed, slowly open the slide gate valve in the pressure line and regulate the operating point.

9.3 Operation

The pump is usually controlled by the overall system's central control system. The following points must be taken into consideration during operation:

- Regulating the pump output via the suction-side slide gate valve can cause damage to the pump and the shaft seals. Regulate the pump output exclusively using the pressure-side slide gate valve.
- If the slide gate valve in the pressure line is closed abruptly or for a long time during operation, this can lead to pressure surges in the pump and therefore to damage to the pump and/or the system. Do not close the slide gate valve in the pressure line abruptly during operation.
- Do not operate the pump against the closed slide gate valve.
- Pumps that are not required (redundancy) must be switched on 1x a week, as the impeller can otherwise seize and shaft seal leaks can develop.
- Check shut-down pumps for damage before recommissioning.

9.4 Ending operation

Procedure

1. Close the slide gate valve in the pressure line.

If a non-return valve is installed and there is sufficient back-pressure in the pressure line, the slide gate valve can remain open.

2. Switch off the pump motor.
3. Close the slide gate valve in the suction line to prevent running empty.

Drain the pump completely at temperatures below freezing or in the event of long down times.

10 Maintenance

10.1 Safety during maintenance

Improper maintenance can lead to personal injury and property damage. Observe the following safety instructions.

- Perform all maintenance work at the specified intervals.
- Maintenance work must only be carried out by qualified and trained personnel.
- When replacing components, use only original spare parts or spare parts approved by the manufacturer.
- Carry out maintenance work only when the pump has been depressurised and drained.
- Perform maintenance work in voltage-free condition. Secure the system to prevent reactivation.
- When pumping hot or very cold pumped fluids, wait until the pump has reached the ambient temperature.
- Close the slide gate valves at the suction nozzle and the pressure nozzle.
- Completely drain the pump casing before opening the pump. Collect the pumped fluid in suitable containers. Exercise particular care with pumped fluids that pose a risk to health and the environment. Wear personal protective equipment. If necessary, wear a protective mask.
- Decontaminate the pump prior to maintenance work in the case of pumped fluids that pose a risk to health and the environment. Document decontamination.

- Note the weight of the pump. There is a risk of crushing and abrasions. Use suitable lifting equipment. Wear protective gloves and safety shoes.
- Observe tightening torques, see Chapter 10.3.1 Tightening torques, page 28.

10.2 Maintenance schedule

Assembly	Maintenance activity	Interval
Pump	Check delivery data (pressure, delivery volume).	Daily
	Check pump operation (smooth, vibration-free).	Daily
	Check pump for leaks (casing and shaft seal).	Daily
	Check that screws are firmly seated, tighten if necessary, see Chapter 10.3.1 Tightening torques, page 28. WARNING! Check only when the pump has been switched off.	Every 6 months
Motor	Check power consumption.	Daily
	Check shaft bearings (temperature, vibrations).	Daily
	Exchange shaft bearings.	After 20,000 hours of operation, but after 3 years at the latest
Pump and motor	Remove dust, dirt and deposits. WARNING! Clean only when the pump has been switched off.	Depending on the degree of soiling

Tab. 10-1 Maintenance activities and intervals

10.3 Maintenance work

10.3.1 Tightening torques

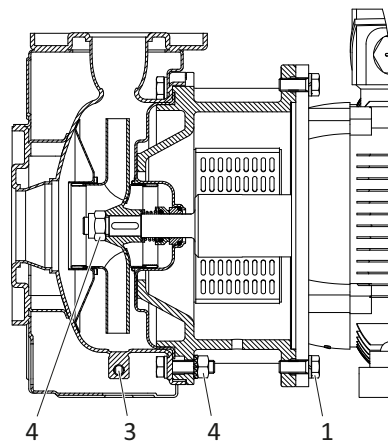

Fig. 10-1 Tightening torques

Item	Thread	Tightening torque [Nm]
1	M10	50
	M12	75
	M16	75
2	M8	25
	M10	50
	M12	75
3	G1/8	Sealed in ¹
	G3/8	Tighten by hand
4 ²	M16	35
	M20	55
	M24	80

¹ Liquid sealant e.g. Weicon AN 305-72

² Self-locking hexagon nut with clamping part

Tab. 10-2 Tightening torques depending on the thread

10.3.2 Exchanging shaft bearings

Defective and worn shaft bearings lead to consequential damage. Vibrations, increased noise emissions and increased power consumption with otherwise constant operating conditions indicate wear.

The temperature of the shaft bearing must not exceed 90°C (measured at the motor casing, outer side).

The shaft bearings have lifetime lubrication, are maintenance-free and cannot be re-lubricated. Under normal operating conditions, the shaft bearings should be exchanged after 20,000 hours of operation, but after 3 years at the latest. In the case of high ambient temperatures, corrosive or very dusty environments, the shaft bearings must be checked more frequently and exchanged earlier if necessary.

To exchange the shaft bearings, contact the motor manufacturer or commission a specialist workshop.

10.3.3 Removing the shaft seal

Removing the shaft seal is similar on all pumps. The example shown here can be applied to all pumps. Refer to the spare part drawing for the specific design.

The numbers in **bold** print in the legend correspond to the part numbers on the spare part drawing.

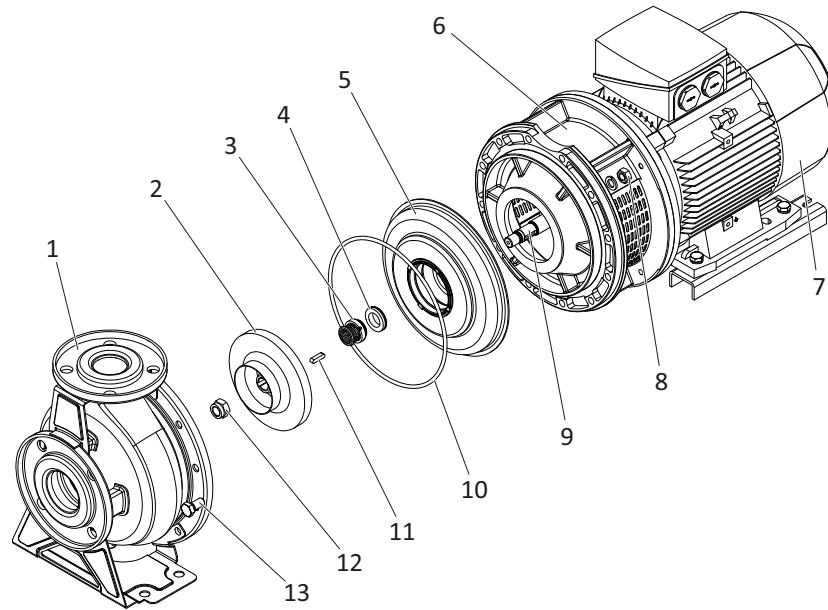

Fig. 10-2 Removing the shaft seal, example

- 1 **100** Casing
- 2 **230** Impeller
- 3 **433** Shaft seal, rotating unit
- 4 **433** Shaft seal, counter ring with O-ring
- 5 **160** Cover
- 6 **341** Lantern
- 7 **801** Motor
- 8 **920** Nut
- 9 **210** Shaft
- 10 **412** O-ring
- 11 **940** Key
- 12 **920** Nut
- 13 **901** Hexagon screw

NOTICE

Improper removal

Improper removal can cause damage to the sealing surfaces.

- Work with particular caution.
- Avoid damaging the sealing surfaces.

To remove the shaft seal, the pump should be positioned vertically on the motor and secured to prevent tipping.

Prerequisite

- The pump has been cleaned and decontaminated if necessary.

Procedure

1. Release the hexagon screws **(13)**.
2. Remove the casing **(1)** and the O-ring **(10)**.
3. Release the impeller **(2)** retainer.
4. Remove the impeller. If the impeller is stuck, use suitable tools, e.g. a puller.
5. Remove the key(s) **(11)** from the shaft **(9)**.
6. Carefully pull off the rotating unit of the shaft seal **(3)**.
7. Remove the cover **(5)**.
8. Press the counter ring with the O-ring **(4)** out from the counter ring seat.

10.3.4 Installing the shaft seal

Installing the shaft seal is similar on all pumps. The following chapters describe the installation of the different types of shaft seals. Refer to the spare part drawing for the specific design.

NOTICE

Damaged and contaminated sealing elements

Improper installation can damage or contaminate sealing elements and sealing surfaces. This can result in leaks.

- Work with particular caution and pay attention to cleanliness.
- Do not touch sliding surfaces with fingers.
- Avoid damaging the sealing elements and sealing surfaces.
- Use only undamaged components.
- Sealing elements with elastomers made of EP rubber must be free of oil and grease. Prevent contact with oils and greases.

To install the shaft seal, the pump should be positioned vertically on the motor and secured to prevent tipping.

Moisten the elastomers of the sealing elements with low-surface-tension water.

10.3.4.1 Installing the mechanical seal with elastomer bellows and O-ring

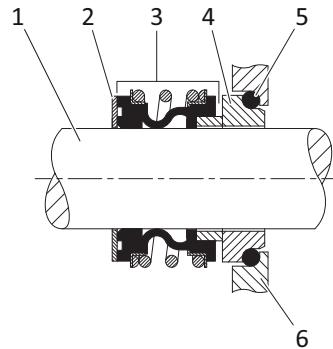

Fig. 10-3 Design of mechanical seal with elastomer bellows and O-ring

- 1 Shaft
- 2 Supporting ring
- 3 Rotating unit
- 4 Counter ring
- 5 O-ring
- 6 Counter ring seat in the cover

A suitable plastic tube can make it easier to push on the components.

1. Position the cover on the motor.
2. Carefully press the counter ring **(4)** together with the O-ring **(5)** into the counter ring seat **(6)** in the cover.

NOTE: The counter ring with O-ring can also be pressed into the counter ring seat before positioning the cover.

3. Push the rotating unit **(3)** onto the shaft **(1)** with rotating movements until it lies against the counter ring.
4. Push on the supporting ring **(2)**.
5. Continue with Chapter 10.3.5 Installing the casing, page 34.

10.3.4.2 Installing the mechanical seal with conical spring

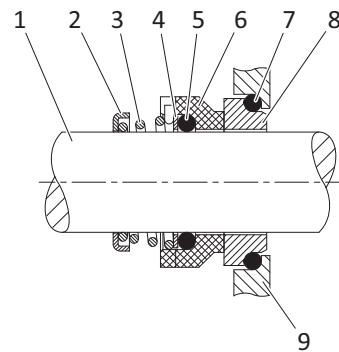

Fig. 10-4 Design of the mechanical seal with conical spring

- 1 Shaft
- 2 Chamber ring
- 3 Conical spring
- 4 Supporting ring
- 5 O-ring
- 6 Sliding ring
- 7 O-ring
- 8 Counter ring
- 9 Counter ring seat in the cover

A suitable plastic tube can make it easier to push on the components.

1. Position the cover on the motor.
2. Carefully press the counter ring (**8**) together with the O-ring (**7**) into the counter ring seat (**9**) in the cover.

NOTE: The counter ring with O-ring can also be pressed into the counter ring seat before positioning the cover.

3. Push the sliding ring (**6**) onto the shaft (**1**) until it lies against the counter ring.
4. Push the O-ring (**5**) onto the shaft and press it into the sliding ring with the aid of the supporting ring (**4**).
5. Push on the conical spring (**3**). The journal of the conical spring must be located in the groove of the sliding ring.
6. Push on the chamber ring (**2**).
7. Continue with Chapter 10.3.5 Installing the casing, page 34.

10.3.5 Installing the casing

Installing the casing is similar on all pumps. The example shown here can be applied to all pumps. Refer to the spare part drawing for the specific design.

The numbers in **bold** print in the legend correspond to the part numbers on the spare part drawing.

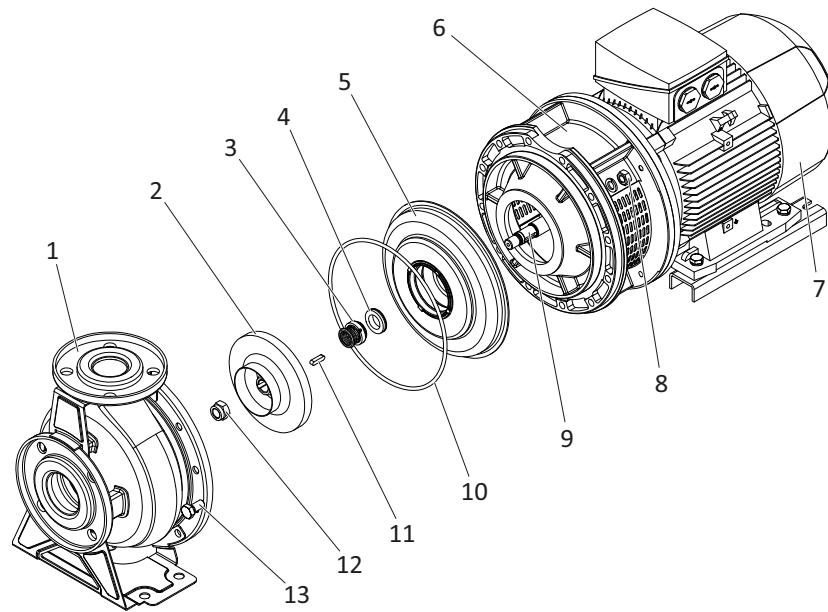

Fig. 10-5 Installing the casing, example

- 1 **100** Casing
- 2 **230** Impeller
- 3 **433** Shaft seal, rotating unit
- 4 **433** Shaft seal, counter ring with O-ring
- 5 **160** Cover
- 6 **341** Lantern
- 7 **801** Motor
- 8 **920** Nut
- 9 **210** Shaft
- 10 **412** O-ring
- 11 **940** Key
- 12 **920** Nut
- 13 **901** Hexagon screw

To install the casing, the pump should be positioned vertically on the motor and secured to prevent tipping.

Prerequisite

- The cover and the shaft seal have been installed installed.
- The sealing elements and sealing surfaces do not reveal any damage and have been cleaned.

Procedure

1. Press the key **(11)** into the key groove.
2. Push the impeller **(2)** onto the shaft **(9)**.
3. Fasten the impeller with the nut **(12)**.
4. First expand the new O-ring **(10)** and place it on the sealing surface in the cover **(5)**.
5. Position the casing **(1)**. Make sure that the O-ring is seated correctly.
6. Use the hexagon screws **(13)** and the washers to bolt the casing. Only slightly tighten the hexagon screws at first.
7. Tighten the hexagon screws **(13)** that are opposite to each other. Observe tightening torques, see Chapter 10.3.1 Tightening torques, page 28.

11 Faults

11.1 Safety during fault rectification

Improper fault rectification can lead to personal injury and property damage. Observe the following safety instructions.

- Fault rectification must only be carried out by qualified and trained personnel.
- When replacing components, use only original spare parts or spare parts approved by the manufacturer.
- Carry out fault rectification only when the pump has been depressurised and drained.
- Carry out fault rectification in voltage-free condition. Secure the system to prevent reactivation.
- When pumping hot or very cold pumped fluids, wait until the pump has reached the ambient temperature.
- Before opening the pump, close the slide gate valve at the suction nozzle and the pressure nozzle.
- Completely drain the pump casing before opening the pump. Collect the pumped fluid in suitable containers. Exercise particular care with pumped fluids that pose a risk to health and the environment. Wear personal protective equipment. If necessary, wear a protective mask.
- Decontaminate the pump prior to fault rectification in the case of pumped fluids that pose a risk to health and the environment. Document decontamination.

11.2 Fault table

Contact the manufacturer in the event of faults that are not listed here.

Fault	Cause	Fault rectification
Pump blocked	Bearing damage on the motor shaft	– Exchange shaft bearings.
	Impeller blocked	– Remove deposits and foreign objects from the interior of the pump.
Head/delivery rate too low	Pump and/or suction line not completely ventilated or filled	– Ventilate and fill pump and/or suction line.
	Suction head too high/system NPSH value too low	– Completely open the slide gate valve in the suction line. – Check the foot valve/suction strainer. – Increase the fluid level if necessary.
	Gas content in the pumped fluid too high	– Re-seal the suction line. – Check the suction strainer. – Increase the fluid level if necessary.
	Air pocket formation in the suction line	– Change the suction line. – Install a vent valve.
	Incorrect direction of rotation	– Check the electrical connection, change if necessary.
	Pump component wear	– Exchange components.
	Rotational speed too low	– Contact the manufacturer.
	Density/viscosity of the pumped fluid higher than specified in the order confirmation	– Contact the manufacturer.
Pump not running smoothly	Suction head too high/system NPSH value too low	– Completely open the slide gate valve in the suction line. – Check the foot valve/suction strainer. – Increase the fluid level if necessary.
	Air pocket formation in the suction line	– Change the suction line. – Install a vent valve.
	Pump running outside of the characteristic curve	– Re-regulate the operating point.
	Forces from the pipe system are acting on the pump	– Check pipe connections, the pump fastening and the pipe clamp mounting spacing, and correct if necessary.
Leaks on casing parts	Connecting screws loosened	– Tighten the connecting screws.
	Shaft seal worn	– Renew the shaft seal.

Fault	Cause	Fault rectification
Drive overloaded	Pump running outside of the characteristic curve	– Re-regulate the operating point.
	Rotational speed too high	– Contact the manufacturer.
	Density/viscosity of the pumped fluid higher than specified in the order confirmation	– Contact the manufacturer.
Shaft seal leaking extensively	Shaft seal worn	– Renew the shaft seal.
Motor protection tripping	Pump running outside of the characteristic curve	– Re-regulate the operating point.
	Rotational speed too high	– Contact the manufacturer.
	Density/viscosity of the pumped fluid higher than specified in the order confirmation	– Contact the manufacturer.
	Motor protection device not set correctly or defective	– Check the motor protection device, exchange if necessary.
Pump becomes hot	Suction head too high/system NPSH value too low	– Completely open the slide gate valve in the suction line. – Check the foot valve/suction strainer. – Increase the fluid level if necessary.
	Gas content in the pumped fluid too high	– Re-seal the suction line. – Check the suction strainer. – Increase the fluid level if necessary.
	Air pocket formation in the suction line	– Change the suction line. – Install a vent valve.
	Delivery rate too low	– Re-regulate the operating point.

Tab. 11-1 Causes and rectification of faults

12 Disposal

12.1 Safety during disposal

Improper disposal can lead to personal injury and property damage. Observe the following safety instructions.

- Disposal must only be carried out by qualified and trained personnel.
- Decontaminate the pump prior to disposal in the case of pumped fluids that pose a risk to health and the environment. Document decontamination.

- Note the weight of the pump and the individual components. There is a risk of crushing and abrasions. Use suitable lifting equipment. Wear protective gloves and safety shoes.
- Observe the statutory regulations concerning the disposal of industrial waste.

12.2 Disposing of the pump

Prerequisite

- The pump has been cleaned thoroughly and decontaminated if necessary.

Procedure

1. Properly disassemble the pump.
2. Separate components according to materials, e.g.:
 - Metal
 - Plastic
 - Electrical scrap
 - Greases and lubricants
3. Dispose of components according to local specifications or send for controlled disposal. Send reusable materials for recycling.

12.3 Returning

If necessary, the pump can be sent to the manufacturer for maintenance. The address can be found on the cover of these operating instructions.

Prerequisite

- The pump has been cleaned thoroughly and decontaminated if necessary.

Procedure

1. Fill in the certificate of unobjectionability completely.
2. Properly seal the pump openings.
3. Package the pump on a pallet for safe transport.
4. Send the pump and the certificate of unobjectionability to the manufacturer.

i Information

Pumps without a certificate of unobjectionability will not be opened by the manufacturer.

13 Annex

13.1 Content of the declaration of conformity

EU Declaration of Conformity
according to EC Machinery Directive 2006/42/EC, Annex II, 1 A

We,

EDUR-Pumpenfabrik
Eduard Redlien GmbH & Co. KG
Edisonstraße 33
24145 Kiel
Germany

hereby declare that the machine designated in the following complies with the fundamental health and safety requirements of the EC Directive.

Designation of the machine:

CB 32, CB 40, CB 50, CB 65, CB 80,
CBL 32, CBL 40, CBL 50, CBL 65, CBL 80,
CBF 32, CBF 40, CBF 50,
CBFL 32, CBFL 40, CBFL 50, CBFL 65,

The precise type designation is located on the pump type plate.

Model designation and factory number, see cover sheet.

Applied harmonised standards:

DIN EN ISO 12100:2011
DIN EN 809:2012

Representative for compiling the relevant technical documents:

Tjark Kaeding (Head of Technical Department)
EDUR-Pumpenfabrik, Edisonstraße 33, 24145 Kiel, Germany

13.2 Certificate of unobjectionability

The certificate of unobjectionability can also be downloaded in the service area of the EDUR homepage, www.edur.com.



CERTIFICATE OF UNOBJECTIONABILITY

Please complete this form in detail and attach it to the pump to be repaired.

This certificate of unobjectionability being sent by us, the signer, with the pump and its component parts for inspection-/repair order,

Model: Serial number: Date of delivery:

Reason for inspection-/repair order: Range of application: Pumped medium:

was **not** used for / in liquids hazardous to health or environment. Before dispatch / delivery the pump was drained carefully and cleaned inside and outside. During further handling particular safety measures will not be necessary.

was used for / in liquids hazardous to health or environment.

Before dispatch / delivery the pump was drained carefully and cleaned inside and outside. During further handling particular safety measures will **not** be necessary.

Before dispatch / delivery the pump was drained carefully and cleaned inside and outside. Following safety measures will be necessary with regard to the pumped liquid and rinsing liquids:

Please attach the safety data sheet.

We confirm that the before mentioned information is correct and complete and that the dispatch / delivery is made according to the legal requirements.

Company name and address:

Phone: Telefax: E-Mail:

Name: Position:

Date: Company stamp/Signature:

Please use this delivery address for shipping units to us:

EDUR-Pumpenfabrik Eduard Redlien GmbH & Co. KG • Marie-Curie-Straße 15 • 24145 Kiel, Germany

Index

A

Address
 Manufacturer 5
 Return 5

B

Boiling state 20

C

Casing
 Installation 34
Cavitation 19
Certificate of unobjectionability 39
Compensator 19, 22
Conservation 16
Crane 15
Cross-section change 19

D

Declaration of conformity 39
Design 13
Disposal 38

E

Emission sound pressure level 12

F

Fitting 19
Foot valve 19
Force 20
 Stainless steel casting 21
 Stainless steel sheeting 20
Function 13

I

Industrial truck 16
Initial commissioning 26
Installation location 18
Installation position 18
Insulating plate 22

M

Maintenance schedule 28
Mechanical seal
 Conical spring 14
 Elastomer bellows 14

N

Noise emissions 12
Non-return valve 19

O

Operating instructions 8
Operation 26
 Ending 27

P

Personnel 9
Pipe bend 19
Pipe system 18
Pressure line 18
Protective device 10
Protective equipment 10

Q

Qualifications 9

R

Rated pipe width 19
Rated width 19
Return 38
Rotation direction 7

S

Safety 9
 Disposal 37
 Fault rectification 35
 Installation 17
 Maintenance 27
 Operation 25
 Removal 23
 Storage 16
 Transport 15
Shaft bearings 29
Shaft seal 14
 Installation 31, 32, 33
 Removal 30
Sign 6
Storage 16
Suction line 18
Suction strainer 19
Suction vessel 19

T

Technical data 11

Motor 11

Pump 11

Tightening torque 21, 28

Table 29

Torque 20

Stainless steel casting 21

Stainless steel sheeting 20

Type plate

Motor 8

Pump 7

U

Use

Improper 9

Proper 9

W

Warning 6



Manufacturer

EDUR-Pumpenfabrik
Eduard Redlien GmbH & Co. KG
Edisonstraße 33
24145 Kiel
Germany

☎ +49 431 689868

✉ info@edur.de

🌐 www.edur.com

Delivery address for returns

EDUR-Pumpenfabrik
Eduard Redlien GmbH & Co. KG
Marie-Curie-Straße 15
24145 Kiel
Germany