

Servopneumatics

FESTO

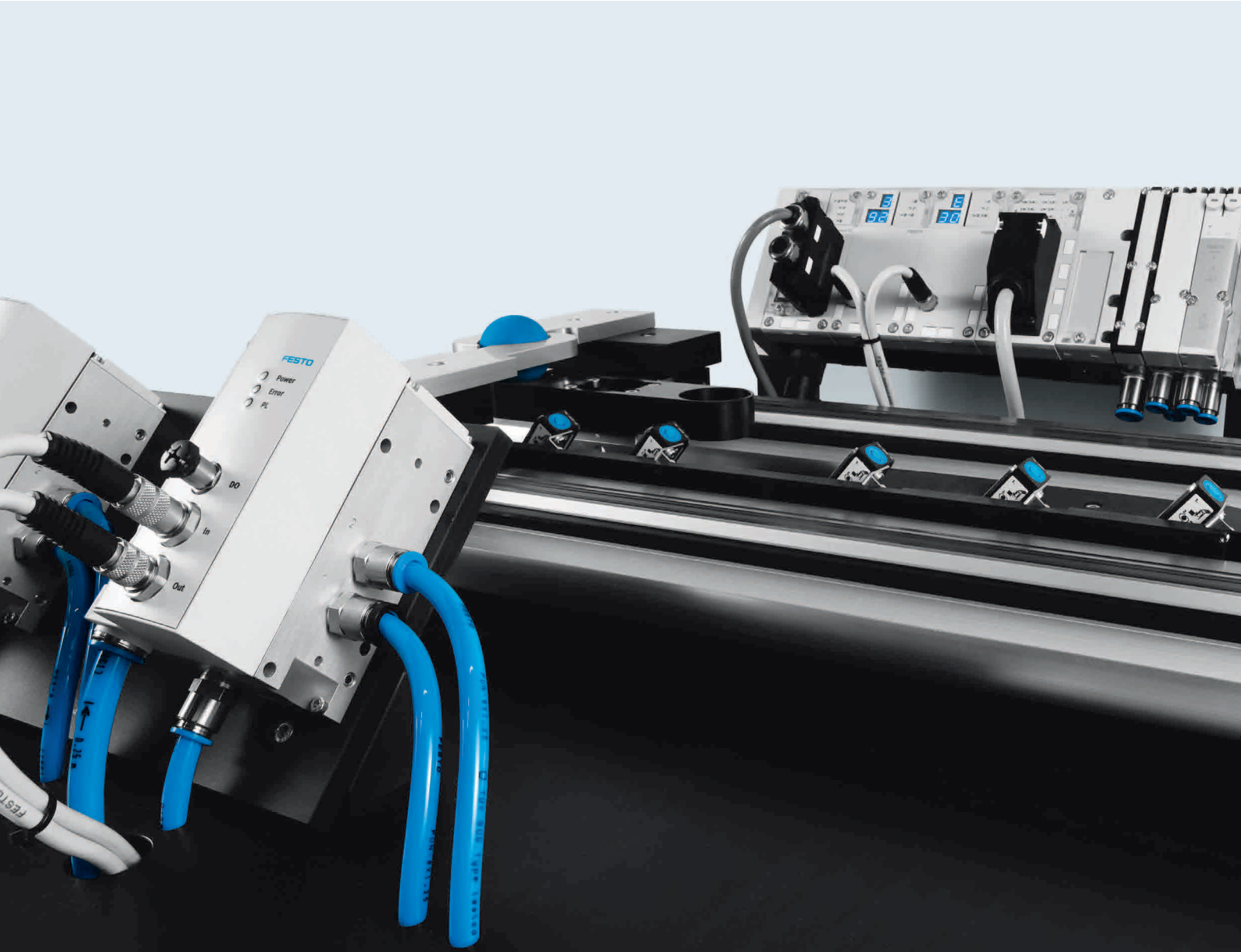

You want expertise.
You are looking for innovation.
We are the specialists in your industry.

→ **WE ARE THE ENGINEERS
OF PRODUCTIVITY.**



Good reasons to choose servopneumatics

Competency in servopneumatics provided by Festo. As the global market leader in servopneumatic systems, Festo now presents the third generation of servopneumatic drive systems. This includes pioneering innovations such as the proportional directional control valve VPWP, which will open up new areas of application and make familiar solutions even simpler.

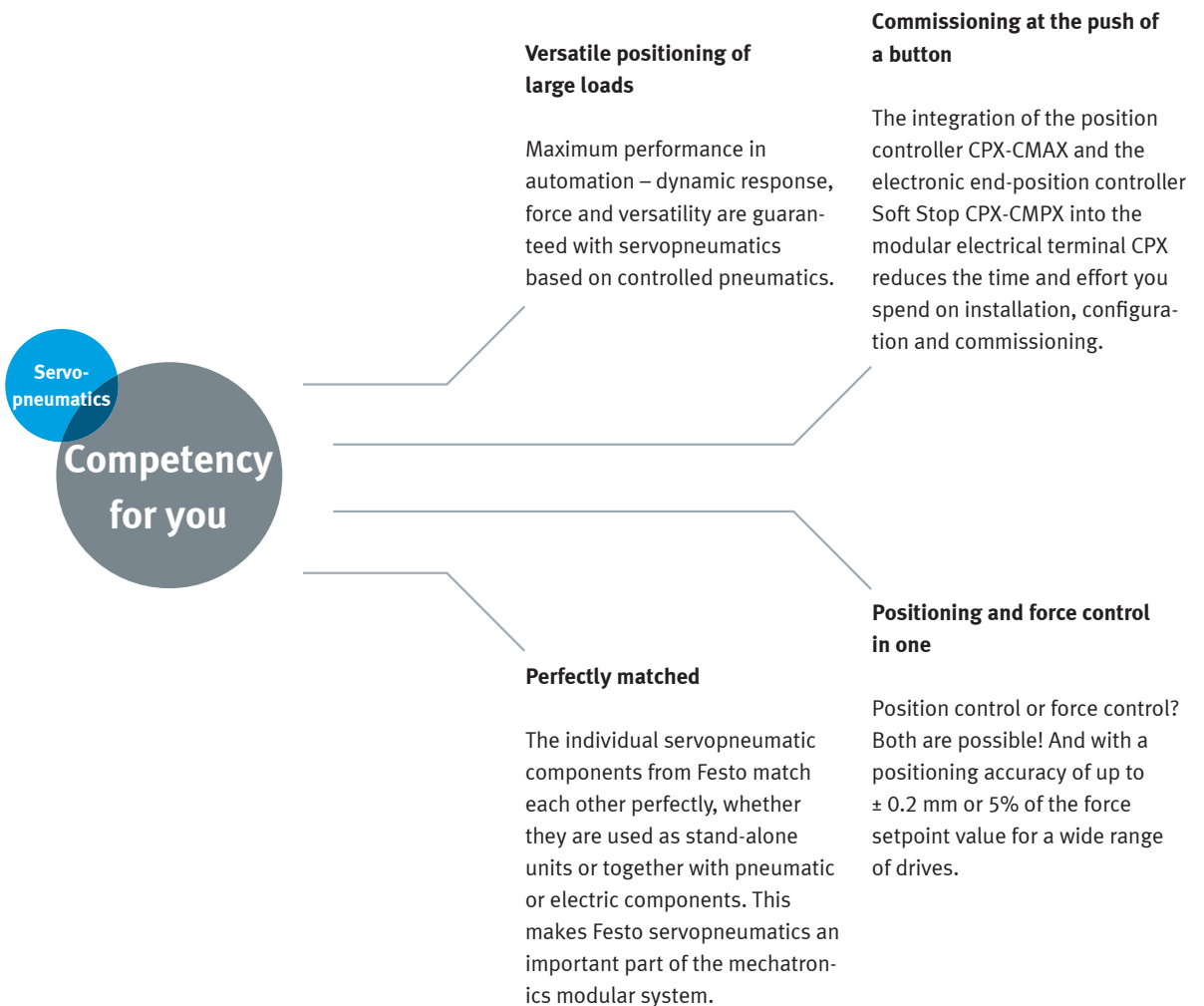

When to use servopneumatics? It all depends on your application!

Pneumatic, servopneumatic, electrical or a combination? The decision is yours. Our experts give you the freedom of choice: Festo can provide you with all three technologies. This means that you can always be sure that you're using the best possible technology. Servopneumatics is recommended whenever the following criteria are important to you:

If you ...

... prefer sturdy, compact,
low-cost solutions

... want a repetition accuracy in
the tenth-of-a-millimetre range



Maximum performance with innovative servopneumatics

... want to reduce air consumption by up to 30% in comparison to standard pneumatics

... are looking for cost benefits of up to 50% compared to electrical solutions because you require new approaches to problem solving that combine positioning and force control

... place great value on optimising machine availability and reducing downtime: each device in the control circuit supplies different diagnostic data

... and a compressed air supply is available.



As the leading provider of automation technology, Festo sets itself high standards, especially when it comes to the product portfolio. That's why our research and development experts have consistently expanded the range of servopneumatic components over the past few years. With a particular focus on three aspects:

- The most powerful, reliable and energy-efficient servopneumatics on the market
- Everything from a single source – a complete range of servopneumatic products with turning, gripping, linear motion and control
- Reasonable prices, even when the overall life cycle costs are taken into account.

The following pages contain more details about our range of servopneumatic products.

Products for servopneumatic systems

The Festo product range, from controllers to drives, makes it extremely easy to implement servopneumatic systems. It is also perfect for integration into the CPX environment with universal fieldbus connection.



One of the latest intelligent modules of the terminal CPX: the positioning module CPX-CMAX. With this module, you can use a wide range of drives such as DGCI/DDLI, DNCI/DDPC and DSMI in position or force-controlled operation.

→ More information on page 7



Brings drives smoothly and quickly into the correct position and then accelerates more quickly: the electronic end-position controller Soft Stop CPX-CMPX. It is also new in the terminal CPX and protects drive and handling units through gentle pneumatic braking.

→ More information on page 8



The proportional directional control valve VPWP with integrated pressure sensors doesn't just give you the best control results; in addition to the sensor data, it also sends diagnostic data to the CPX-CMAX and CPX-CMPX.

→ More information on page 9



The sub-base VABP enables various single-channel switch-off functions to be implemented as part of a safety mechanism for a servopneumatic axis.

→ More information on page 10



Drives with displacement encoder DGCI/DDLI, DNCI/DDPC or DSMI, with linear or rotary motion. They offer the advantages of pneumatics such as dynamic response, force and versatility – all with a positioning accuracy of ± 0.2 mm!

→ More information on page 12

Servopneumatic positioning module CPX-CMAX-C1-1

The new positioning module CPX-CMAX is one of a kind. It is designed for simple servopneumatic control of various pneumatic drive families, linear or rotary. The CPX-CMAX is a positioning and force control module of the modular electrical terminal CPX.

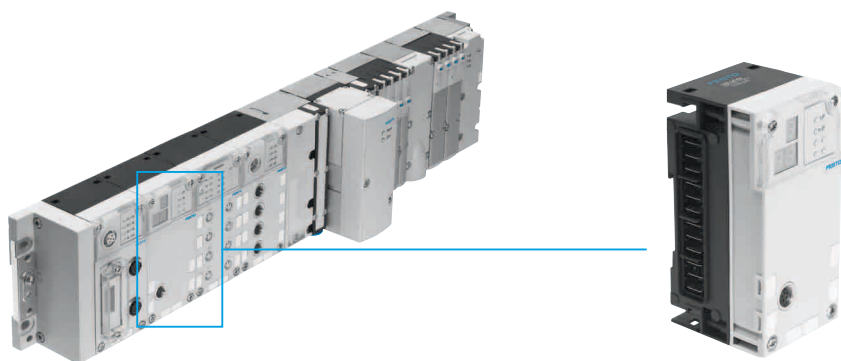

Multi-purpose

Positioning technology using servopneumatics is particularly useful when compact and cost-effective solutions for moving loads typically in excess of 5 kg are required and accuracy within a few tenths of a millimetre is sufficient.

Benefits

- Positioning and force control in one work step
- Compact, low-cost positioning system for sturdy applications
- Fast processes/high productivity thanks to the FCT software tool for simple commissioning with auto-identification and comprehensive diagnostics

PROFI
BUS

CANopen

PROFI
NET

DeviceNet

INTERBUS

EtherNet/IP

CC-Link

EtherCAT

Modbus TCP

Technical data

Moving loads	Horizontal	[kg]	1 ... 450
	Vertical	[kg]	1 ... 150
Controlled force at 6 bar		[N]	30 ... 4200
Positioning accuracy		[mm]	±0.2
Travel speed		[m/s]	Max. 3
Acceleration		[m/s ²]	Max. 30

Electronic end-position controller Soft Stop CPX-CMPX-C-1-H1

With CPX-CMPX, the unique Soft Stop function is making a place for itself in the world of the modular electrical terminal CPX. The electronic end-position controller enables a cycle time reduction of about 30% – and that with almost vibration-free travel to the mechanical end positions. Soft Stop enables highly dynamic movement of loads up to 450 kg.

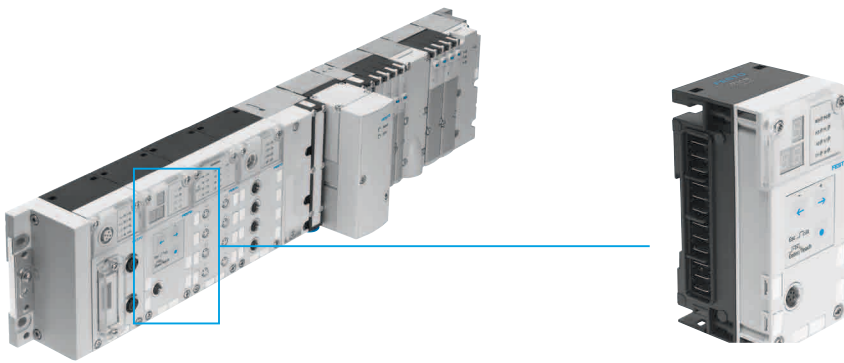

Benefits

- Approx. 30% shorter travel times and up to 30% less air consumption than with comparable standard pneumatic solutions
- Increased cylinder service life
- No vibrations when moving into the end positions
- Suitable for use with all fieldbuses/Ethernet and CEC available in CPX
- Easy commissioning, Festo plug and work

New functions

- Digital data handling
- Pressure sensors provide reliable downtime control
- Two mid-positions can be flexibly adjusted using the fieldbus
- Brake output on proportional valve VPWP

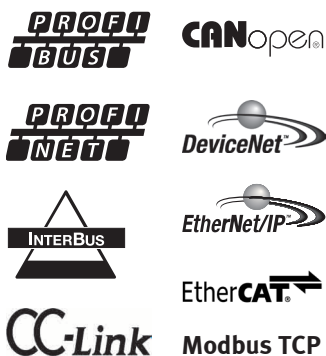

Features			
Moving loads	Horizontal	[kg]	1 ... 450
	Vertical	[kg]	1 ... 150
Actuation	Via all fieldbuses available in CPX Front End Controller FEC and CEC-C1		
Mid-positions	Up to two freely programmable mid-positions, including via the field bus		
	Accuracy $\pm 0.25\%$ of the displacement encoder length, and no less than ± 2 mm		
	Downtime monitoring via pressure sensors in the valve		
	Reliable in combination with the brake function		
Max. cable length between the controller and the drive: 30 m			
Fast, vibration-free travel between two fixed stops			

Proportional directional control valve VPWP for servopneumatics

Teamwork for maximum servopneumatic productivity: the proportional directional control valve VPWP with integrated, digital, serial interface for the servopneumatic positioning system CPX-CMAX and end-position controller CPX-CPMX Soft Stop. With the proportional directional control valve, the force control function is now also available for the position controller CPX-CMAX.

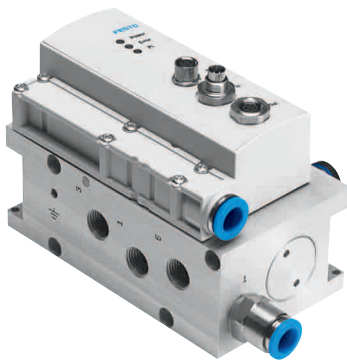

Integrated pressure sensors constantly monitor the pressure in the chambers of the connected drive. This gives you an edge in diagnostics and condition monitoring, as the fully digitised valves supply the controller not only with the sensor data, but also with valuable diagnostic values regarding their own operating status. This is total process reliability!

Multi-sensor control

Integrated pressure sensors and cascade control for optimal, high-precision control results and robust control behaviour. Optimal positioning characteristics with speed and acceleration ramps.

Additional functionality

Digital switching output for actuating

- A shut-off valve or
- A switching valve for a clamping unit

Further benefits

- Long lasting: adaptive "self-tuning" control algorithm
- Faster installation: plug and work with auto-identification
- More productive: comprehensive diagnostic capabilities

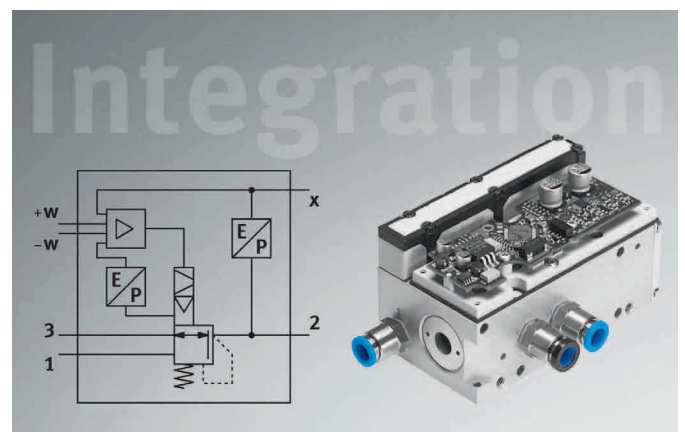

Double sub-base VABP for single-channel switch-off functions

With the sub-base VABP, you can realise different single-channel switch-off functions. It should always form part of any planned safety solution and can be used up to Performance Level C.

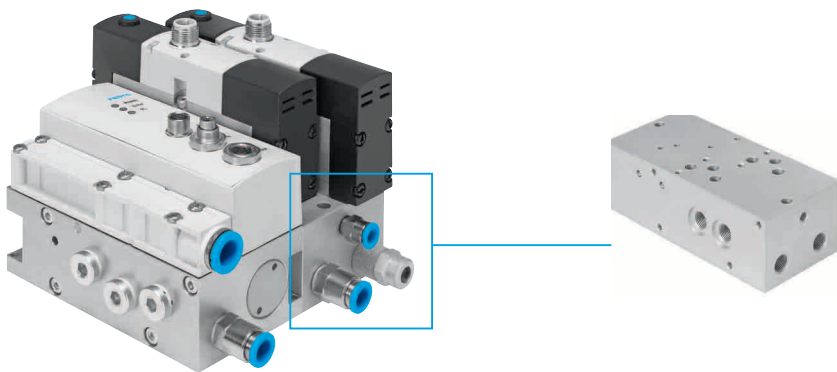

Features

- Can be attached directly to the proportional valve VPWP
- 3 sizes
- Quick and easy to install
- Compact design
- Prepared for ISO directional control valves
- Exclusively uses cost-effective series components
- 4 switch-off functions

Switch-off functions

- Stop [S1-S1']
- De-energise [S2-S2']
- Switch off power [S4-S4']
- Reverse at reduced speed [S3-S2'] or [S2-S3']

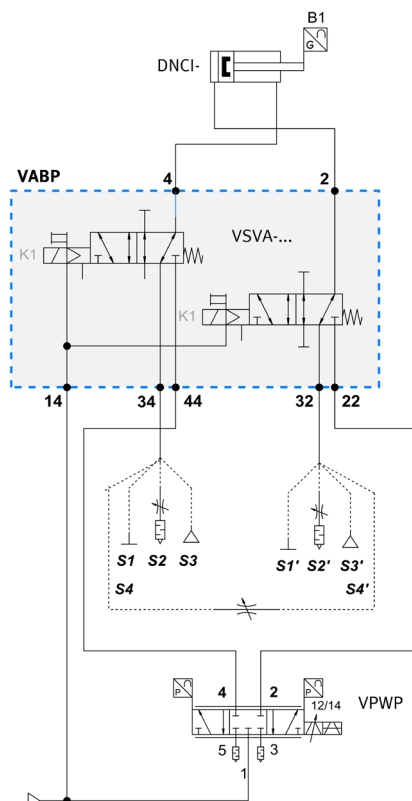

Safety through stopping

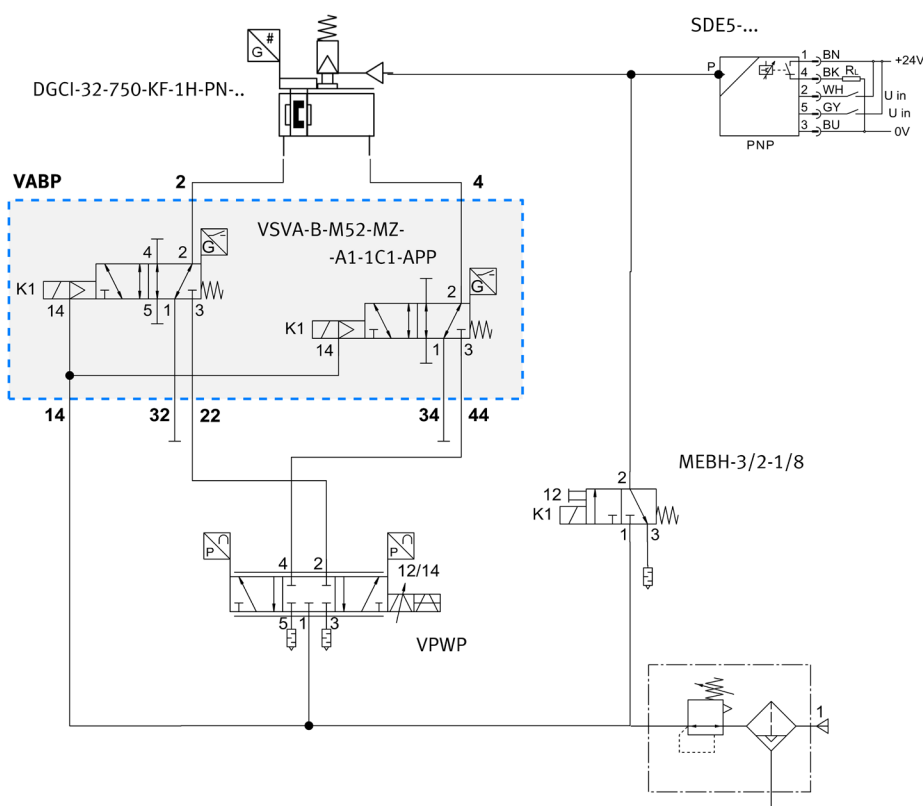

An example: stopping

Features

- Protection against unexpected start-up (2-channel)
- Safety measure: stopping (2-channel)
- Stop category: "1"
- Compressed air supply not shut off

Additional information

- Recommended for vertical axes
- When the emergency stop is activated, the compressed air remains trapped in the drive; the drive is not free of compressed air. The braking unit, together with the servopneumatic controller, can prevent a movement on restart.

Note

For more details, please refer to our safety brochure or the application documentation "VABP – showcasing safety measures", available in PDF format from the download area: [→ www.festo.com](http://www.festo.com)

Drives and displacement encoders

Suitable for many positioning tasks: drives with excellent performance and integrated displacement encoders combine the dynamic response, power and flexibility of pneumatics with a positioning accuracy to within ± 0.2 mm. Servopneumatics can be used to control a large number of both linear and rotary pneumatic drives.

Built-in benefits: integrated displacement encoder

- Compact and flexible, with no inconvenient external attachments
- Long service life thanks to the wear-free, contactless displacement encoder
- Simple installation and assembly thanks to mounting accessories from the corresponding modular cylinder system



Standard cylinder DNCI/DDPC

Technical data

- DNCI in diameters 32, 40, 50 and 63 mm
- DDPC in diameters 80 and 100 mm
- Stroke length: 100 ... 750 mm
- Max. controllable force: 4200 N
- Suitable for CPX-CMAX, CPX-CMPX and as a measurement cylinder

Features

- With contactless displacement encoder for incremental measurement
- Various piston rod variants
- Standard cylinder to ISO 15552
- With optional guide and clamping unit

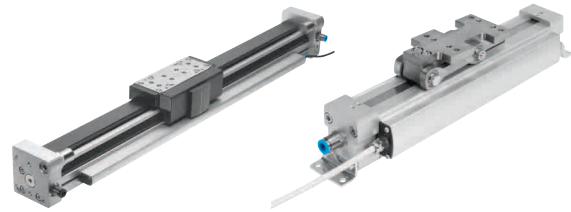

Linear drive DGCI/DDLI

Technical data

- Diameter: 18 ... 63 mm
- Stroke length: 100 ... 2000 mm
- Max. controllable force: 1680 N
- Suitable for CPX-CMAX, CPX-CMPX and as a measurement cylinder

Features

- DGCI: with recirculating ball bearing guide, optional clamping unit, central lubrication and lubrication approved for use in the food industry
- DDLI: without guide – for use with the customers' own recirculating ball bearing guide. With optional moment compensator DARD for backlash-free load coupling
- With displacement encoder for absolute and contactless measuring
- Based on linear drive DGC-K
- System product for handling and assembly technology
- DGCI: with optional clamping unit, central lubrication, plus lubrication approved for use in the food industry

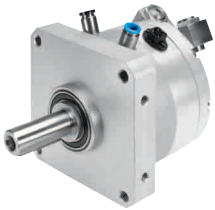

Semi-rotary drive DSMI

Technical data

- Diameter: 25, 40, 63 mm
- Swivel angle: 0 ... 270°
- Mass moment of inertia up to 6000 kg/cm²
- Suitable for CPX-CMAX and CPX-CMPX

Features

- Based on swivel module DSM
- Integrated rotary potentiometer
- Compact design
- Wide range of mounting options



Displacement encoder MLO

Technical data

- Stroke: profile 225 ... 2000 mm, connecting rod 100 ... 750 mm
- Measuring principle: potentiometric, contacting and measuring absolute values
- Measuring principle MME: magnetostrictive, non-contacting and absolute measurement

Features

- Function: analogue or digital
- System product for positioning applications and Soft Stop (SPC11)
- Design: profile or connecting rod
- Cost-effective
- Ideal for retrofitting
- Suitable for CPX-CMAX and CPX-CMPX

Design options

The design of the displacement encoder differs depending on its function, use and location. Measuring absolute values, incremental and contactless or potentiometric – each option has its own strengths. For example, the potentiometric method is perfect for retrofitting.

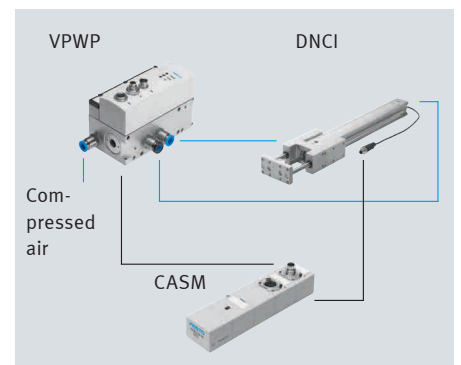
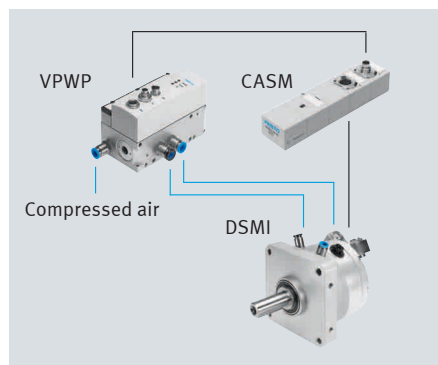
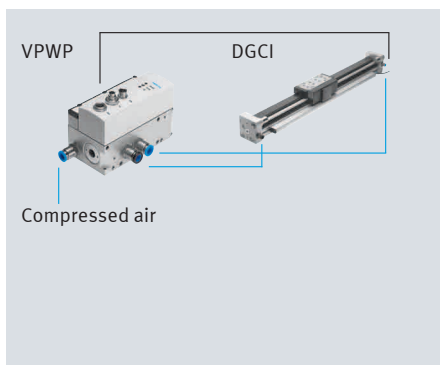
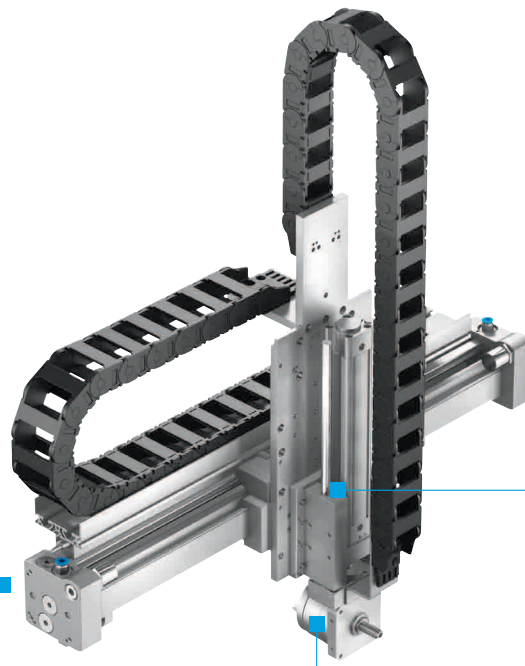

CPX terminal CMAX
or CMPX



Proportional directional control valve VPWP with integrated, digital, serial interface for the servopneumatic positioning system CPX-CMAX and end-position controller CPX-CPMX Soft Stop. With the proportional directional control valve, the force control function is also available for the position controller CMAX. The directly mounted double sub-base VABP can be used to realise various switch-off functions.

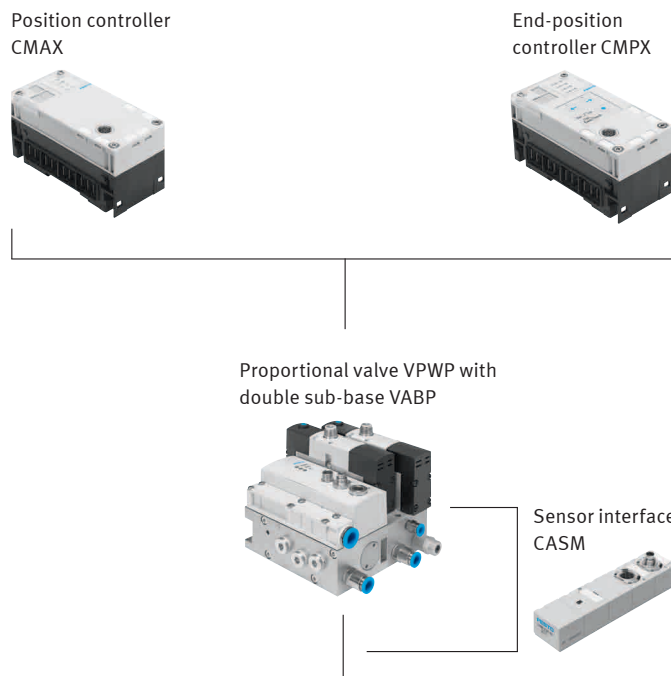

Linear drives with displacement encoders

DNCI/DDPC



DGCI/DDLI



Swivel modules with displacement encoders

DSMI-B



Note



The sensor interface CASM is a signal transducer. It is used in DNCI and DDPC, and also in potentiometers that are used as displacement encoders. This keeps the connecting lines used to transmit the analogue measurement signal short.

Servopneumatics – the ideal application

In which areas of application can servopneumatics be recommended as the best technology? As a rule of thumb: wherever pneumatic force needs to be combined with precision, high speed and sensitive handling. The following pages will show you a few examples.

The example of the woodworking machine:

The task

Wooden planks of different thicknesses are sawn into slats of different widths using high-speed saws. To easily identify if a board is passing through, the roller is prepositioned slightly below the board thickness.

During the sawing process, the plank is pressed down by three rollers ($m = 80 \text{ kg}$) and moves at 3 m/s.

The contact pressure can be adjusted to suit the type of wood. Once the plank has gone through the machine, the contact rollers must return to their initial position without coming into contact with the conveyor.

The data for the plank that is being fed into the machine are transmitted to the system via the fieldbus.

The solution

Standard cylinders DDPC-100-100 with proportional directional control valves VPWP-6 control the motion of the contact rollers. The core of the control unit is a CPX terminal with a local CPX-CEC, a Profibus interface, 2 CPX-CMAX modules and an I/O module.

New for CPX-CMAX: switching to next record.

This ensures it reliably moves from one operating status to another. The unit can easily switch between position control and force control on an event-controlled basis.

The CPX-CEC controls the CPX-CMAX modules via I/O and fieldbus.

The benefits

- The stand-alone solution independently controls the pressing process
- Fast and flexible
- One system for position and force control, freely programmable
- Safety functions integrated into the system: emergency stop and "Board fed in" signal for locking the system
- Clear error diagnostics

Servopneumatics is ideal for production technology...

... when flexible, force-controlled pressing is required.

... when workpieces need to be pressed with a defined force.



Label picker

The task

Labels must be glued to packages of different sizes and heights in one-second cycles. The packages travel past the labelling unit on a conveyor. The package height is measured upstream of the station using an analogue distance sensor and transmitted directly to the positioning axis. The working stroke of the label picker is 50 to 500 mm. The advance and return stroke must take place within one second. The label ejection position is 15 mm above the package. The label picker has a weight of 5 kg.

The solution

A standard cylinder DNCI-32-500 with integrated incremental displacement encoder and guide unit FENG-KF ensure the advance and return stroke. This positioning unit is controlled by a modular electrical terminal CPX with local controller CPX-CEC, an axis controller CPX-CMAX, an analogue module and an 8 I/O module. It can also be controlled via fieldbus. The standard cylinder DNCI is pneumatically actuated by a proportional directional control valve VPWP-4 with “slow travel upward” emergency-off circuit.

The benefits

- Flexible solution
- Compact design
- Highly dynamic response, 60 cycles per minute
- No heat restrictions, even at full duty cycle
- With fieldbus or as a stand-alone system
- Significant cost benefits compared to an electric cylinder with a servo motor

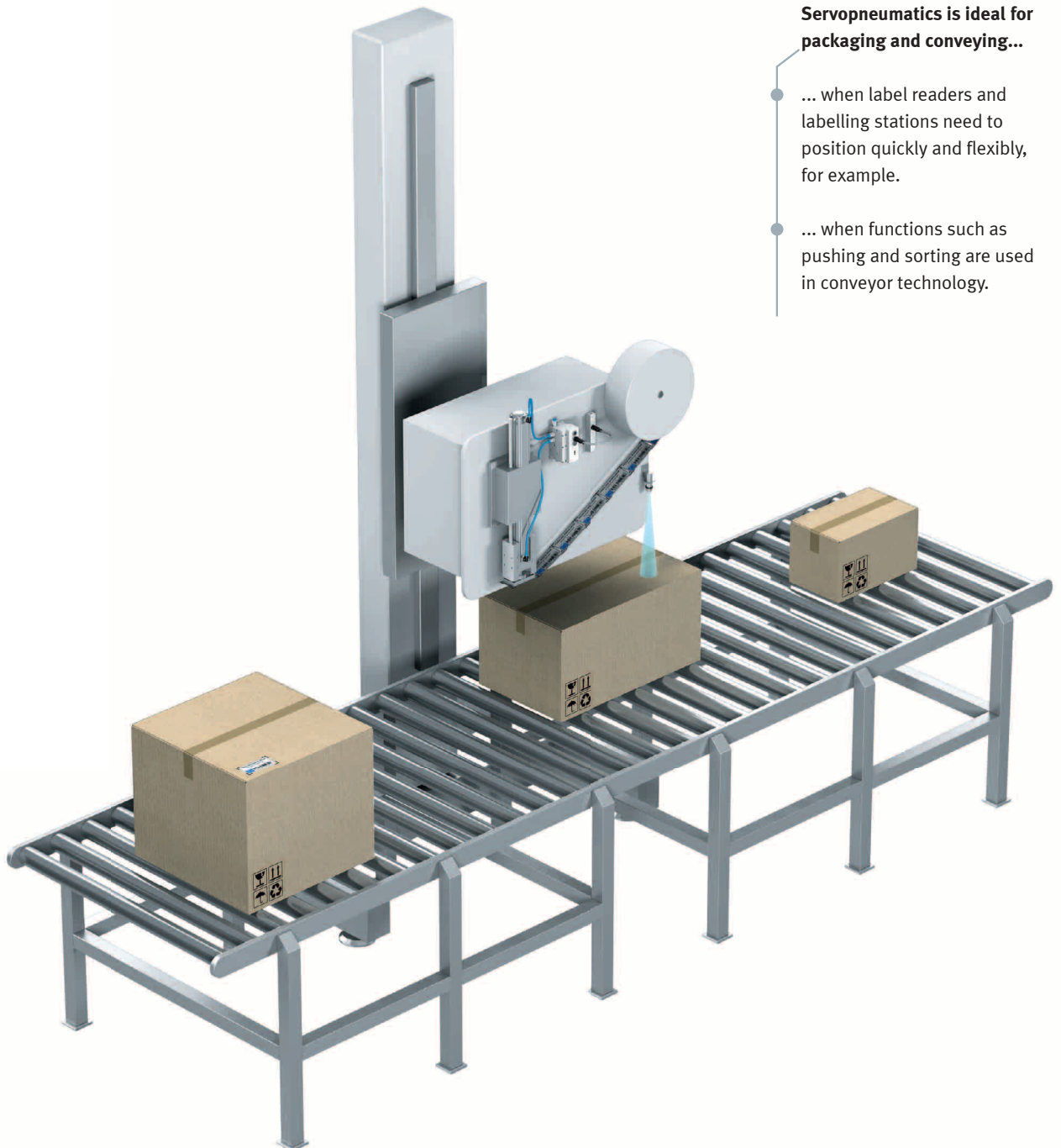

Servopneumatics is ideal for packaging and conveying...

... when label readers and labelling stations need to position quickly and flexibly, for example.

... when functions such as pushing and sorting are used in conveyor technology.

Large gripper

The task

Large containers need to be securely gripped – even in the event of an emergency stop. The gripper module is installed on an industrial robot, which is used to grip sensitive products of different sizes and types. To enable fast robot movements, the customer required a module that would take up very little space and had the lightest possible drives. The position and force values are specified for the particular product via fieldbus.

The solution

Depending on the gripper type, drives with recirculating ball bearing guide DGCI or cylinder with piston rod DNCI are attached to the customer's own guide, actuated with a proportional directional control valve VPWP-6. The “gripper fingers” are controlled by a modular terminal CPX with PROFIBUS and two axis controllers CPX-CMAX each. Position and force values are specified via the human-machine interface in direct operation. Thanks to additional switching valves, the product is securely held even in the event of an emergency stop.

The benefits

- Compact design and light drive with large force reserve
- Quick placement of the “gripper fingers”
- Fast switching from position to force control
- Various bus protocols available, including easy retooling
- Set values at the push of a button in the event of a product change

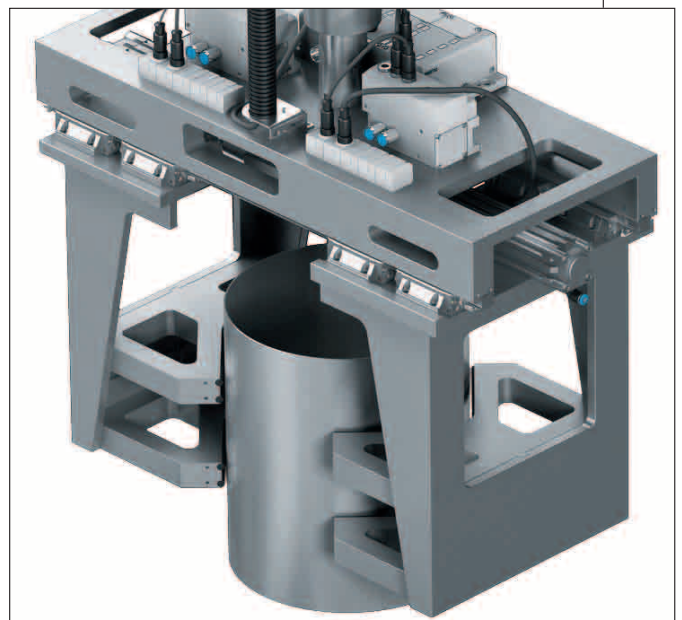

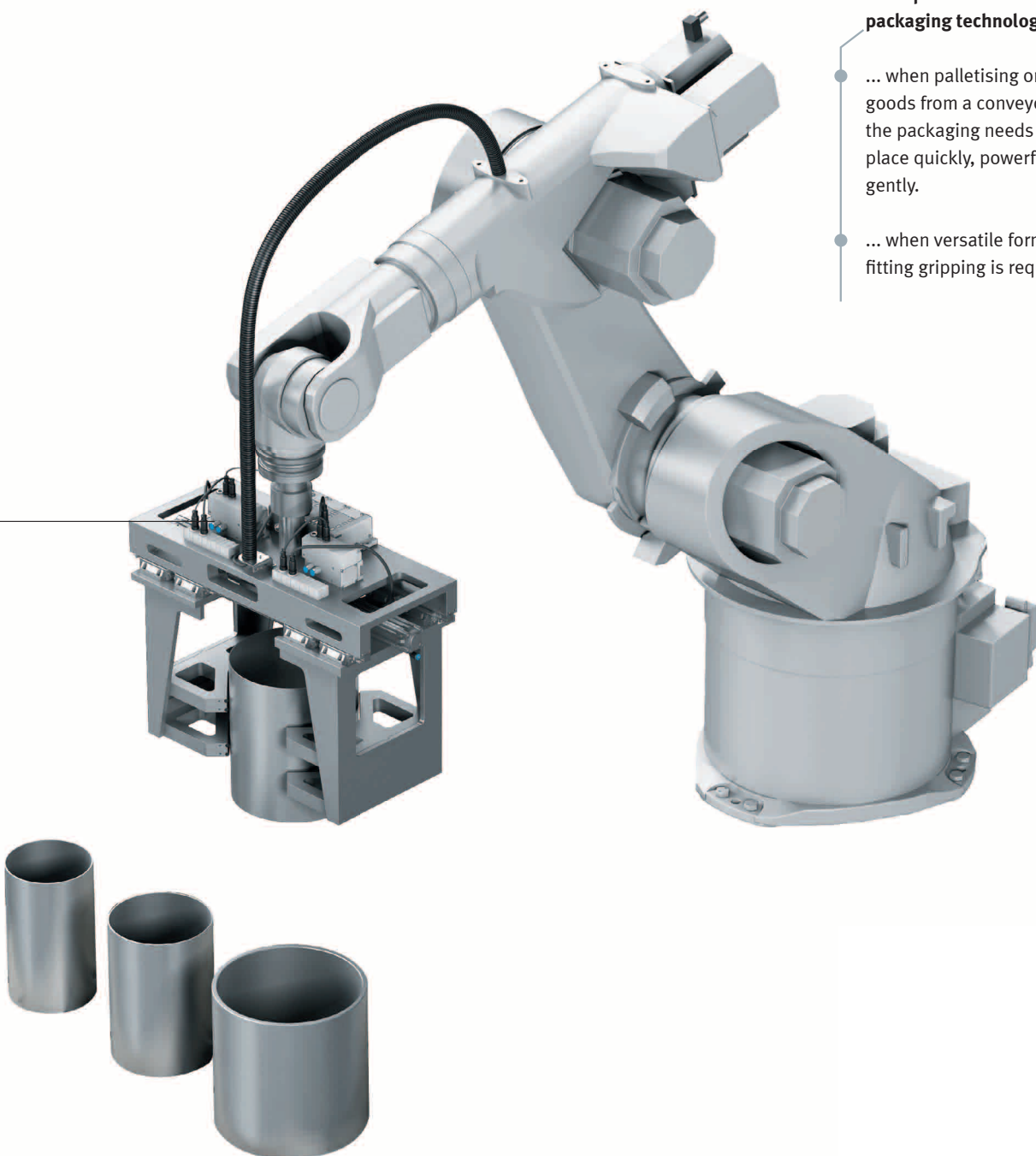

Servopneumatics is ideal for packaging technology...

... when palletising or moving goods from a conveyor belt into the packaging needs to take place quickly, powerfully and gently.

... when versatile form or force-fitting gripping is required.

Hot-plate welding

The task

Two plastic bowls are welded together in a hot-plate welding system. To this end, a heating plate that has been heated to the correct temperature is moved between the two workpieces. These move towards the plate until firm contact has been established, so that their surfaces heat up and become malleable. In order to remove the hot plate, the bowls need to be moved apart quickly and then immediately pressed together again. The surface of the workpiece must only be allowed to cool slightly, so the work step must not take longer than a few seconds. Depending on the workpieces, the strokes are 50 ... 150 mm; an accuracy of 0.5 mm is required. The forces are between 100 ... 500 N.

The solution

Servopneumatics positions quickly and generates a defined force – perfect for pressing workpieces against a stop.

The required precision of 0.5 mm is easy to maintain using this drive technology. For a stroke of 100 mm the DDPC cylinders need just under 0.4 s. These carry out all the work steps up to the force-controlled pressing of the parts at the end of the process. In case of an emergency stop, additional directional control valves ensure that the plastic bowls are forced apart. This prevents the workpieces from overheating. If there is a power failure, an additional compressed air volume kicks in and supplies the necessary drive energy required to reach the "cold" position.

The benefits

- Highly flexible
- Force and position control in one; easy to switch
- Compact
- Defined emergency stop behaviour
- Can be controlled directly using fieldbus or the customer's control system
- For a wide range of fieldbus protocols
- "Cold" drive technology
- Simple and clear installation
- All the services of the CPX world can be used as add-ons.

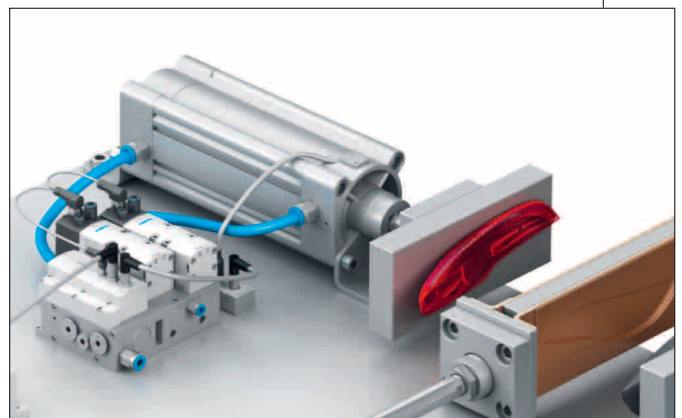

Servopneumatics is ideal for production technology...

... when workpieces need to be pressed on or in with flexibility and force control.

... when heavy parts up to over 400 kg need to be positioned flexibly and quickly.

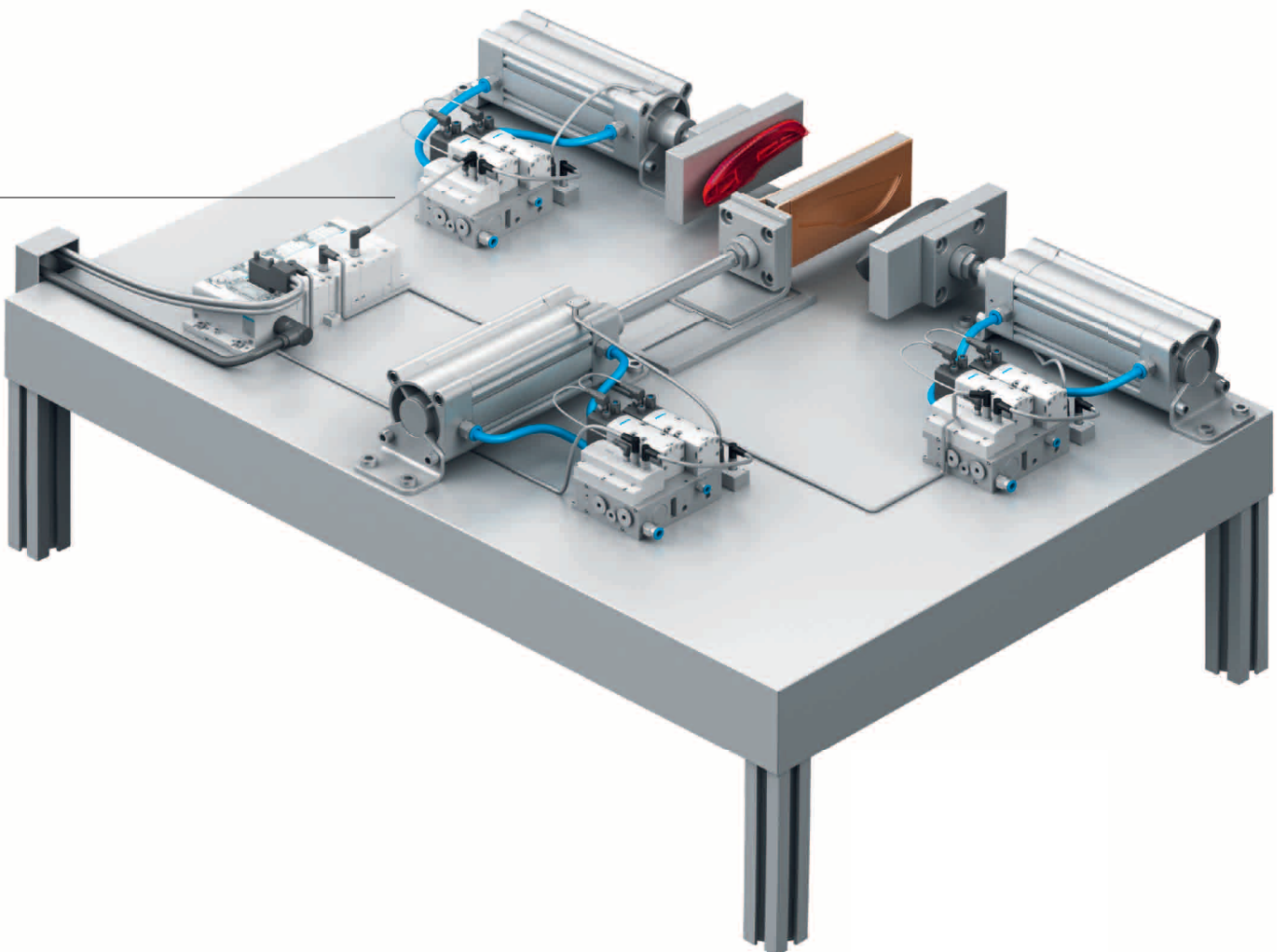



Productivity

We are the engineers of productivity

There are four outstanding characteristics with which we successfully implement your automation tasks and provide you with increased productivity: security, efficiency, simplicity and competency. These make us what we are for you: engineers of productivity.

More information: → www.festo.com/whyfesto