

Forgotten Books

— www.forgottenbooks.com —

Copyright © 2016 FB &c Ltd.

All rights reserved. No part of this publication may be reproduced, distributed, or transmitted in any form or by any means, including photocopying, recording, or other electronic or mechanical methods, without the prior written permission of the publisher, except in the case of brief quotations embodied in critical reviews and certain other noncommercial uses permitted by copyright law.

TRANSACTIONS
OF THE
SAN DIEGO SOCIETY OF NATURAL HISTORY

VOLUME 16

1970-1972

Printed from the
W. W. Whitney Publication Endowment

COMMITTEE ON PUBLICATION

CARL L. HUBBS
JOSEPH R. JEHL, JR.
ARNOLD ROSS

CONTENTS

1. Studies on the Tetracitidae (Cirripedia: Thoracica): a proposed new genus for the Austral species *Tetracitita purpurascens breviscutum*. By Arnold Ross. 24 February 1970 1-12
2. The shallow water anomuran crab fauna of southwestern Baja California, Mexico. By Janet Haig, Thomas S. Hopkins and Thomas B. Scanland. 4 June 1970 13-32
3. Comparative biology of American black widow spiders. By B. J. Kaston. 24 July 1970 33-82
4. Eastern Pacific Crown-of-Thorns starfish populations in the lower Gulf of California. By Thomas Dana and Arthur Wolfson. 24 November 1970 83-90
5. Evolution of *Peromyscus* on northern islands in the Gulf of California, Mexico. By Timothy E. Lawlor. 24 February 1971 91-124
6. *Lampetra (Entosphenus) lethophaga*, new species, the nonparasitic derivative of the Pacific lamprey. By Carl L. Hubbs. 30 April 1971 125-164
7. Recent ostracodes from Clipperton Island, eastern tropical Pacific. By Edwin C. Allison and John C. Holden. 14 May 1971 165-214
8. Studies on the Tetracitidae (Cirripedia: Thoracica): a new tetracitellan from India. By Arnold Ross. 21 May 1971 215-224
9. Stratigraphy of the Poway area, southwestern California. By Gary L. Peterson. 9 July 1971 225-236
0. Herpetofauna of the Pacific coast of north central Baja California, Mexico, with a description of a new subspecies of *Phyllodactylus xanti*. By Dennis L. Bostic. 25 August 1971 237-264
1. A new genus of Chthamalidae (Cirripedia) from the southeastern Pacific island of San Ambrosio. By Arnold Ross. 26 October 1971 265-278
2. The larval and pupal stages of four species of *Cafius* (Coleoptera: Staphylinidae) with notes on their biology and ecology. By Gary J. James, Ian Moore and E. F. Legner. 5 November 1971 279-290
3. The color patterns of downy young ratites and tinamous. By Joseph R. Jehl, Jr. 15 November 1971 291-302
4. Cenozoic calcareous nannofossils from the Pacific Ocean. By David Bukry. 7 December 1971 303-328
5. An upper Pleistocene marine fauna from Mission Bay, San Diego, California. By J. Philip Kern, Tom E. Stump and Robert J. Dowlen. 29 December 1971 329-338
6. The systematic position of *Urosalpinx carolinensis* Verrill, 1884 with comments on the genus *Mohnia* Friele, 1878. By George E. Radwin. 12 January 1972 339-342

**STUDIES ON THE TETRACLITIDAE
(CIRRIPIEDIA: THORACICA): A PROPOSED
NEW GENUS FOR THE AUSTRAL SPECIES
*TETRACLITA PURPURASCENS BREVIS CUTUM***

ARNOLD ROSS

TRANSACTIONS

**OF THE SAN DIEGO
SOCIETY OF
NATURAL HISTORY**

VOL. 16, NO. 1 24 FEBRUARY 1970

STUDIES ON THE TETRACLITIDAE (CIRRIPEDIA: THORACICA): A PROPOSED NEW GENUS FOR THE AUSTRAL SPECIES *TETRACLITA PURPURASCENS BREVISCUTUM*

ARNOLD ROSS

ABSTRACT. — *Epopella* gen. nov. is proposed for the Auckland Islands species *Tetraclita purpurascens* forma *breviscutum* Broch, 1922, a solid-walled tesseroporan. *Elminius plicatus* Gray and *E. simplex* Darwin are assigned provisionally to this new genus on the basis of morphological similarities. *Epopella*, containing the most primitive tetraclitids, is inferred to have evolved during the early Paleogene, and it is from this group that *Tesseropora* and later tesseroporans are derived.

RESUMEN. — *Epopella* gen. nov. esta propuesto para el especies de las Islas Auckland *Tetraclita purpurascens* forma *breviscutum* Broch, 1922, un tesseroporan que tiene una pared sólida. *Elminius plicatus* Gray y *E. simplex* Darwin son asignados provisionalmente a este género nuevo en el base de semejanzas morfológicas. *Epopella*, conteniendo las tetraclitids más primitivas se infiera que ha evolucionada durante del Paleógena, y es de este grupo que *Tesseropora* y tesseroporans más tarde están derivado.

Knowledge of the tetraclitid fauna of Australia, Tasmania, New Zealand, and the islands comprising the Antipodean Province is limited. Aside from the taxon Broch (1922: 337) described as *Tetraclita purpurascens* forma *breviscutum*, the following species are known from this region: *Tesseropora rosea* (Darwin, 1854: 335; Linzey, 1942: 280; Pope, 1945: 366; Wisely and Blick, 1964: 166), *Tetraclita vitiata* (Stephenson, 1968: 51), and *Tetraclitella purpurascens* (Darwin, 1854: 337; Linzey, 1942: 279; Foster, 1967a: 83; 1967b: 35).

Tetraclita purpurascens forma *breviscutum* was collected by the Th. Mortensen Pacific Expedition (1914-1916) on Auckland Island, the largest of several islands in the Auckland Islands Group (Fig. 1), and more recently it has been found on Rose Island. This species has neither been reported nor found in collections from any other locality and appears to be endemic to the Auckland Islands. Unfortunately, there is little known about the ecology of this tetraclitid.

Hiro (1939: 275) noted differences in the opercular plates of *T. purpurascens* forma *breviscutum* that indicated it was not closely related to the nominate subspecies. However, he failed to indicate the affinities of this form to other tetraclitid groups. In re-examining the type specimens I noted several salient wall structures that readily characterize this taxon at the generic and specific level and suggest that its affinities are to the tesseroporan rather than to the tetraclitellan lineage (Ross, 1969: 238). Consequently, the "forma" *breviscutum* is elevated to specific rank and the genus *Epopella* proposed for it and two other related species.

FAMILY TETRACLITIDAE Gruvel

Remarks. — The familial diagnosis presented earlier (Ross, 1969: 238) is emended to include those species that lack an inner lamina and have an outer lamina permeated by cuticular chitin.

STUDIES ON THE TETRACLITIDAE (CIRRIPEDIA: THORACICA): A PROPOSED NEW GENUS FOR THE AUSTRAL SPECIES *TETRACLITA PURPURASCENS BREVISUTUM*

ARNOLD ROSS

ABSTRACT. — *Epopella* gen. nov. is proposed for the Auckland Islands species *Tetraclita purpurascens* forma *breviscutum* Broch, 1922, a solid-walled tesseroporan. *Elminius plicatus* Gray and *E. simplex* Darwin are assigned provisionally to this new genus on the basis of morphological similarities. *Epopella*, containing the most primitive tetraclitids, is inferred to have evolved during the early Paleogene, and it is from this group that *Tesseropora* and later tesseroporans are derived.

RESUMEN. — *Epopella* gen. nov. esta propuesto para el especies de las Islas Auckland *Tetraclita purpurascens* forma *breviscutum* Broch, 1922, un tesseroporan que tiene una pared sólida. *Elminius plicatus* Gray y *E. simplex* Darwin son asignados provisionalmente a este género nuevo en el base de semejanzas morfológicas. *Epopella*, conteniendo las tetraclitids más primitivas se infiera que ha evolucionada durante del Paleógena, y es de este grupo que *Tesseropora* y tesseroporans más tarde están derivado.

Knowledge of the tetraclitid fauna of Australia, Tasmania, New Zealand, and the islands comprising the Antipodean Province is limited. Aside from the taxon Broch (1922: 337) described as *Tetraclita purpurascens* forma *breviscutum*, the following species are known from this region: *Tesseropora rosea* (Darwin, 1854: 335; Linzey, 1942: 280; Pope, 1945: 366; Wisely and Blick, 1964: 166), *Tetraclita vitiata* (Stephenson, 1968: 51), and *Tetraclitella purpurascens* (Darwin, 1854: 337; Linzey, 1942: 279; Foster, 1967a: 83; 1967b: 35).

Tetraclita purpurascens forma *breviscutum* was collected by the Th. Mortensen Pacific Expedition (1914-1916) on Auckland Island, the largest of several islands in the Auckland Islands Group (Fig. 1), and more recently it has been found on Rose Island. This species has neither been reported nor found in collections from any other locality and appears to be endemic to the Auckland Islands. Unfortunately, there is little known about the ecology of this tetraclitid.

Hiro (1939: 275) noted differences in the opercular plates of *T. purpurascens* forma *breviscutum* that indicated it was not closely related to the nominate subspecies. However, he failed to indicate the affinities of this form to other tetraclitid groups. In re-examining the type specimens I noted several salient wall structures that readily characterize this taxon at the generic and specific level and suggest that its affinities are to the tesseroporan rather than to the tetraclitellan lineage (Ross, 1969: 238). Consequently, the "forma" *breviscutum* is elevated to specific rank and the genus *Epopella* proposed for it and two other related species.

FAMILY TETRACLITIDAE Gruvel

Remarks. — The familial diagnosis presented earlier (Ross, 1969: 238) is emended to include those species that lack an inner lamina and have an outer lamina permeated by cuticular chitin.

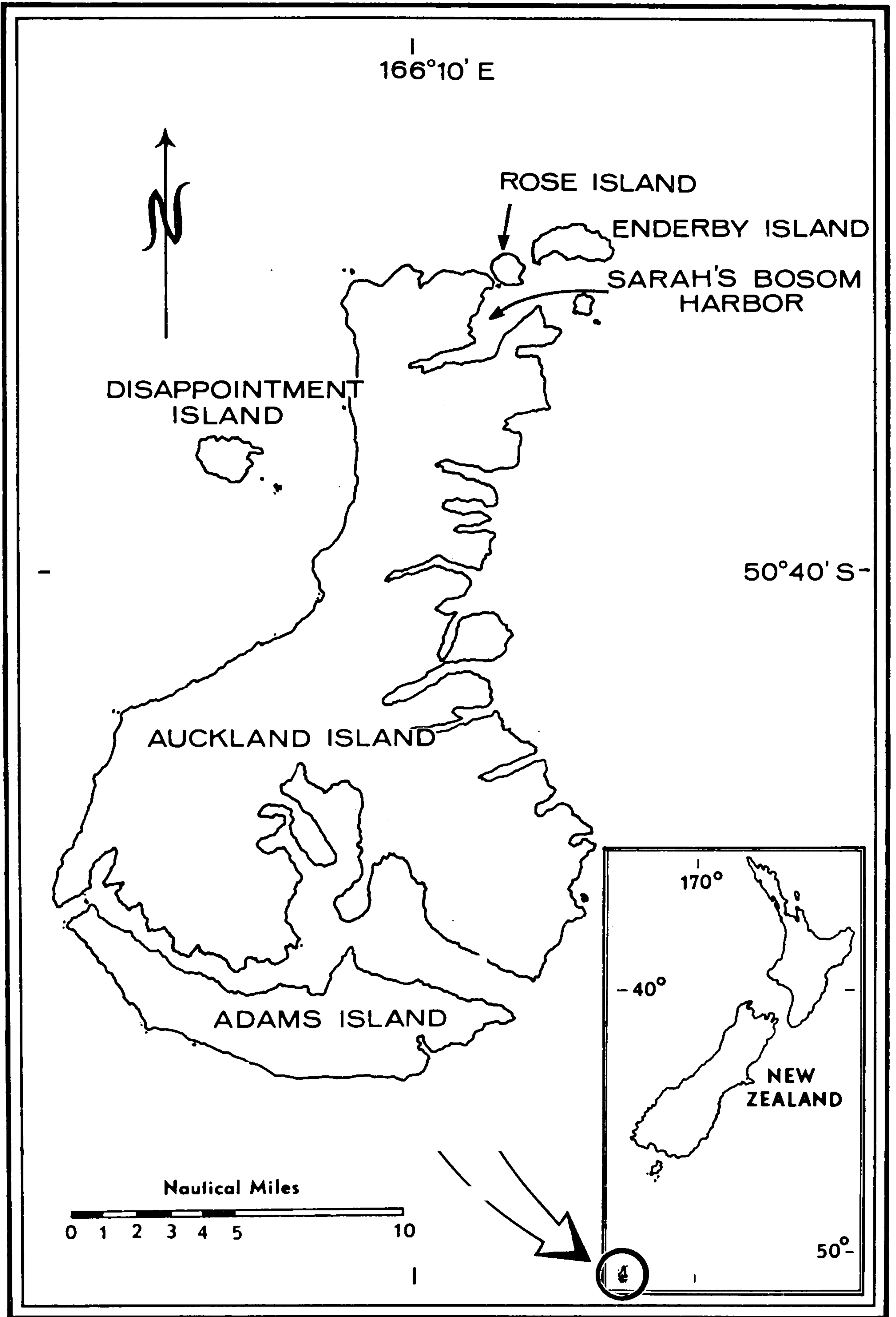

Figure 1. Map of Auckland Islands Group, and its position relative to New Zealand (inset). The known occurrences of *Epopella brevicutum* are Sarah's Bosom Harbor and Rose Island.

KEY TO GENERA OF THE TESSEROPORAN GROUP

1. Parietal tubes uniformly distributed in one row 2
1. Parietal tubes uniformly distributed in more than two rows, or lacking 3
2. Parietal tubes bearing transverse septa; scutum lacking depressor muscle crests (1 sp., eastern Pacific, Pliocene) *Tesseroplax*
2. Parietal tubes lacking transverse septa; scutum bearing depressor muscle crests (5 spp., Indo-West Pacific, Recent; Italy, Oligocene) *Tesseropora*
3. Inner lamina present; longitudinal septa continuous; sheath adpressed, basal margin not depending (19 spp., tropical, warm temperate, cosmopolitan, Pliocene to Recent) *Tetraclita*
3. Inner lamina absent; longitudinal septa discontinuous; sheath free with basal margin depending (3 spp., southeast Australia, New Zealand, Recent) *Epopella*

Epopella gen. nov.

Definition. — Shell large, conic; compartments may or may not be discrete; parietes effectively solid, permeated with cuticular chitin, and commonly discontinuous plates or longitudinal lamina depend from inner surface; radii non-tubiferous, narrow or obsolete; basis membranous; scutum triangular, higher than wide, bearing crests for depressor muscles; tergum narrow, spur not well separated from basi-scutal angle, truncate basally; mandible with 4 teeth, basal comb, and spine-like inferior angle; maxilla I with 10-16 spines comprising medial cluster of cutting edge.

Type species. — *Tetraclita (Tetraclita) purpurascens* forma *breviscutum* Broch, 1922, Recent, Auckland Island.

Etymology. — Named in honor of Elizabeth C. Pope, the Australian Museum, in recognition of her many contributions to the Cirripedia of the Australian region.

Epopella breviscutum (Broch)

Tetraclita (Tetraclita) purpurascens forma *breviscutum* Broch, 1922: 337, figs. 71, 72.

Tetraclita (Tetraclitella) purpurascens forma *breviscutum*: Hiro, 1939: 275.

Material. — Rose Island, Auckland Islands; intertidal; J. C. Yaldwyn, coll., January, 1963; 2 dried specimens lacking appendages and body; in collections of Dominion Museum, Wellington, New Zealand.

Sarah's Bosom Harbor (Port Ross), Auckland Island, Auckland Islands; under stones at low tide; Th. Mortensen Pacific Expedition, November 26, 1914; 5 complete specimens; in collections of Universitetets Zoologiske Museum, Copenhagen, Denmark.

Supplementary Description. — Shell low, conic; grayish-white; parietes deeply eroded; growth ridges discernible along basal margin only; orifice pentagonal with peritreme eroded; radii extremely narrow or obsolete, with articular surfaces weakly crenate; compartments weakly articulated when not secondarily fused; no inner lamina; longitudinal septa discontinuous basally, not fused, forming separate, smooth, depending plates (Fig. 2d), in general appearance not much unlike that of *Chelonobia testudinaria*; basal margin of sheath free, depending (Fig. 2d). Basis membranous. Measurements (in mm.) of the lectotype (26-XI-14D), paralectotypes (26-XI-A-C,E), and specimens from Rose Island (spec. F, G) are presented in Table 1.

External surface of opercular plates deeply eroded (Fig. 2a, b). Scutum triangular, commonly slightly higher than wide, articular ridge sinuous, about 2/3 length of tergal

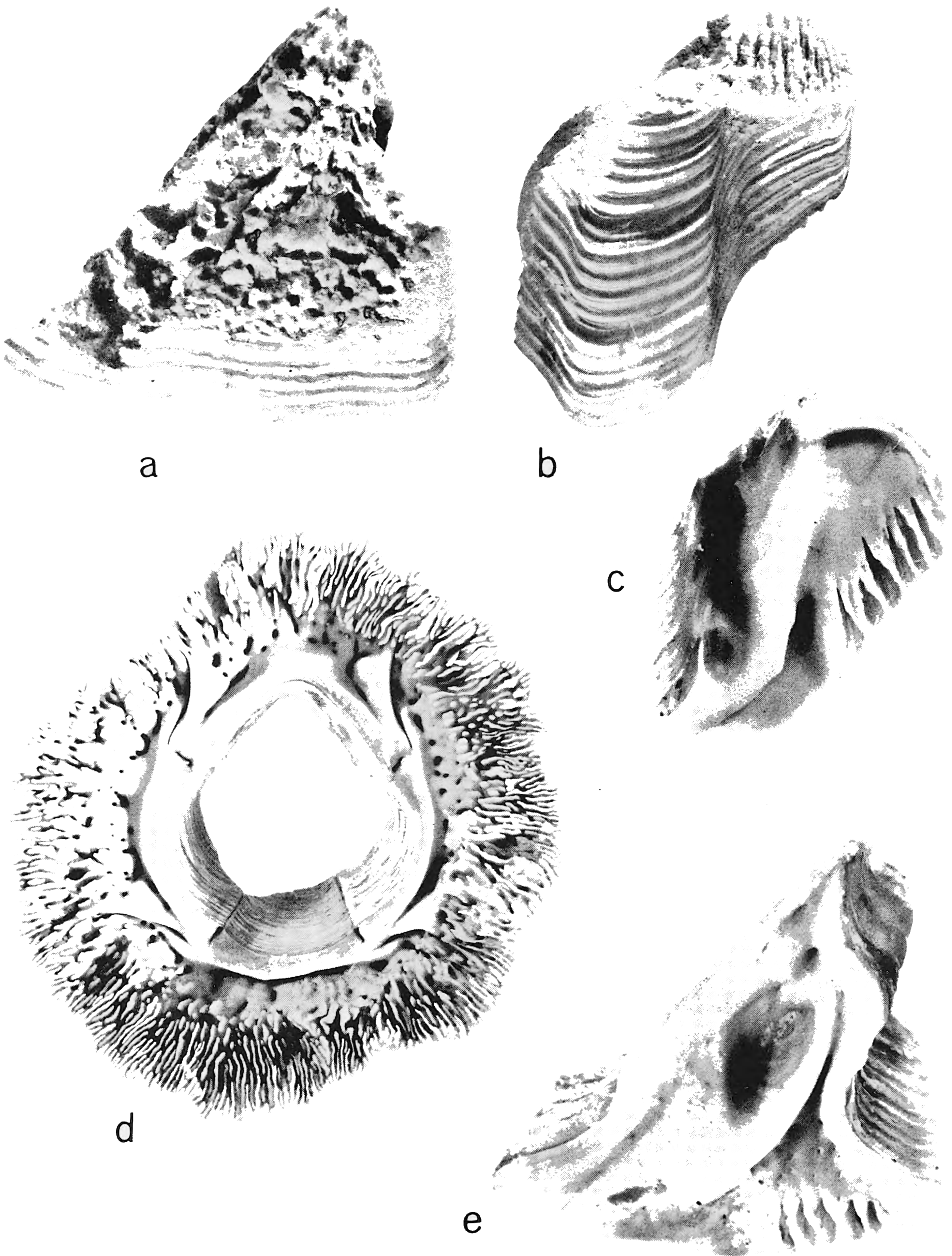

Figure 2. Shell and opercular plates of *Epopella breviscutum*. a, external view of scutum; b, external view of tergum; c, internal view of tergum; d, basal view of shell; e, internal view of scutum. Lectotype (26-XI-14D), a-c, e; paralectotype (26-XI-14A), d.

margin; adductor ridge erect, undercut, fused apically with articular ridge and extending nearly to basal margin; adductor muscle depression ovate, deep; 3-4 crests for rostral

depressor muscle, low, thin, partially hidden by infolding of occludent margin; 4-5 crests for lateral depressor muscle, high, broad, clearly exposed; overall surface of plate pitted (Fig. 2e).

Tergum higher than wide, apically eroded; external longitudinal furrow open, shallow, extending to base of spur; spur truncate basally, width more than 1/2 that of basal margin; articular ridge erect or inclined, undercut along basal portion; articular furrow broad and deep; 5-7 crests for depressor muscles, short, broad, erect, bearing close-spaced, thin, lateral extensions (Fig. 2c).

Table 1. *Measurements of Individual Specimens*

Specimen	Shell			Opercular Plates			
	C-R Dia.	Width	Height	S. H.	S. W.	T. H.	T. W
<i>Auckland Id.</i>							
26-XI-14 A	29.9	29.2	14.4	9.4	8.7	8.3	5.1
26-XI-14 B	31.1	26.9	12.2	8.3	9.1	8.1	5.3
26-XI-14 C	31.0	30.9	14.3	10.1	9.4	8.7	4.9
26-XI-14 D (lectotype)	28.7	25.9	14.8	9.1	9.2	8.4	5.1
26-XI-14 E	32.9	31.4	12.7	8.2	10.2	8.9	5.2
<i>Rose Id.</i>							
F	16.8	19.4	9.4	7.8	7.2	6.4	4.8
G	16.1	18.5	10.8	6.8	6.5	5.1	4.8

Crest of labrum thick, heavily chitinized, with shallow medial notch (Fig. 3f); multidenticulate, 22-39 simple teeth along crest and in notch (Fig. 3g); short soft setae along crest and commonly between the teeth.

Palps bluntly rounded distally; superior margin concave, basal convex; distal setae 1/2 longer than superior; both bipinnate.

Mandible with 5 teeth including inferior angle (Fig. 3a); teeth 2-4 with subsidiary cusps; superior slope of tooth 4 smooth; inferior angle coarsely serrate, 28-42 overlapping, narrowly triangular teeth.

Maxilla I deeply notched subapically (Fig. 3c); spines along cutting edge in 3 clusters; 2 long, stout and 4-6 short, slender spines above notch; 10-16 long or short slender spines medially; 7-15 very short and slender spines basally.

Maxilla II taller than broad (Fig. 3e); anterior margin bilobate; basal lobe covered with cluster of pustules along anterior border.

Rami of cirrus I grossly unequal in length (Fig. 4a); posterior ramus about 1/2 length of anterior ramus. Rami of cirrus II either essentially equal in length or inner ramus slightly shorter; intermediate articles of both rami squat, slightly protuberant; setae on both rami coarsely bipinnate, not comb-like. Rami of cirrus III antenniform (Fig. 4d); outer ramus approximately 3/5 length of inner ramus; basal segments of both rami armed with comb-setae lacking basal guards (Fig. 4e). Cirri IV-VI essentially equal in length with equal rami; 3-5 short, slender setae at each articulation along greater curvature of intermediate articles; a single row of ctenae occurs along lateral face immediately below articulation; commonly 4 pairs of setae on cirri IV-V, and 3 on cirrus VI (Fig. 4f); at base of and between each major pair of setae is a cluster of 4-9 long bristles. Cirral counts for the specimens in the type lot are summarized in Figure 5.

Intromittent organ annulated throughout its length, and sparsely covered with short

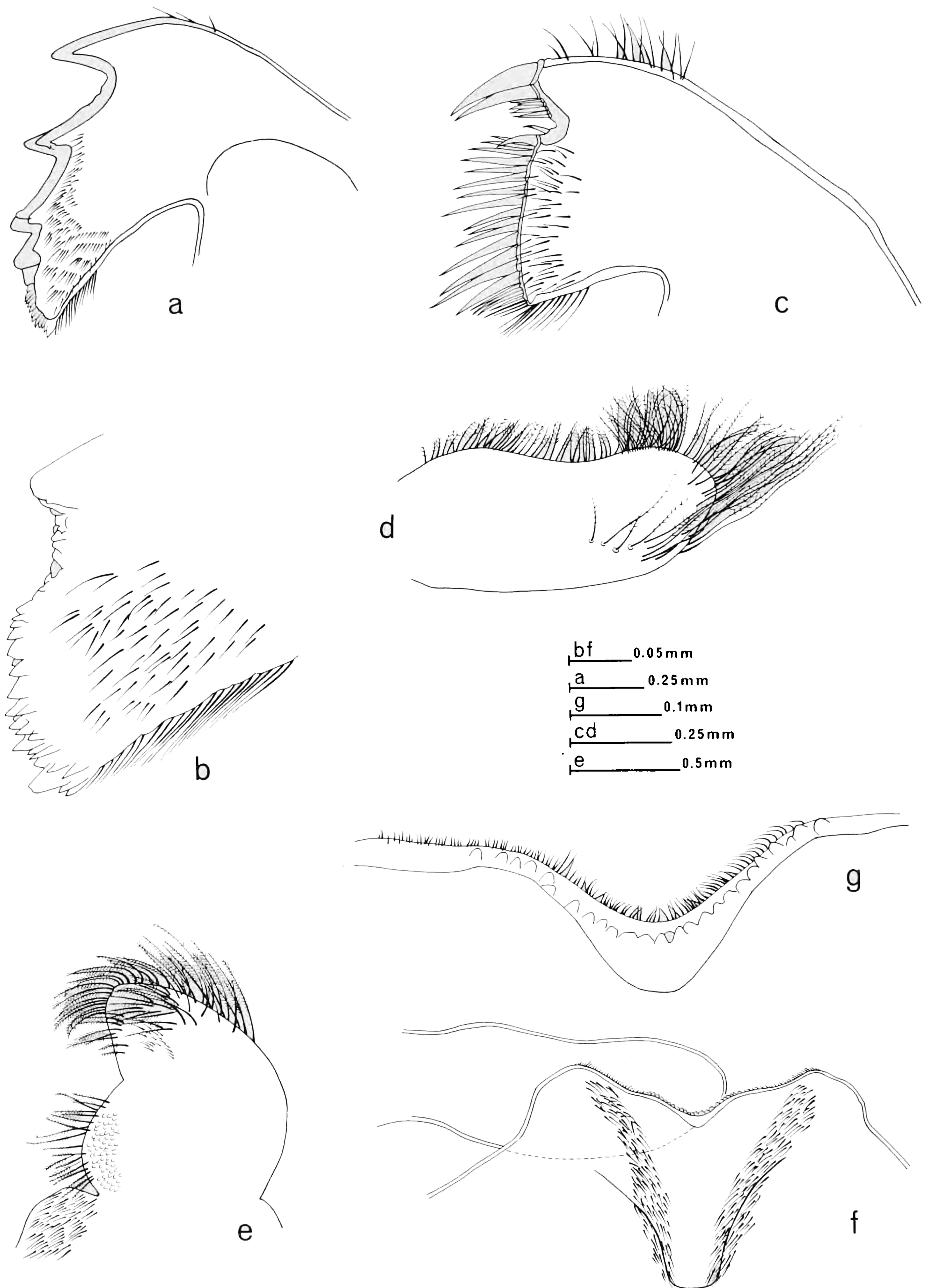

Figure 3. Trophi of *Epopella breviscutum*. a, mandible; b, enlarged view of inferior angle of mandible in fig. a; c, maxilla I; d, palp; e, maxilla II; f, labrum and palp; g, enlarged view of labral crest. Lectotype (26-XI-14D), a-e, g; paralectotype (26-XI-14B), f.

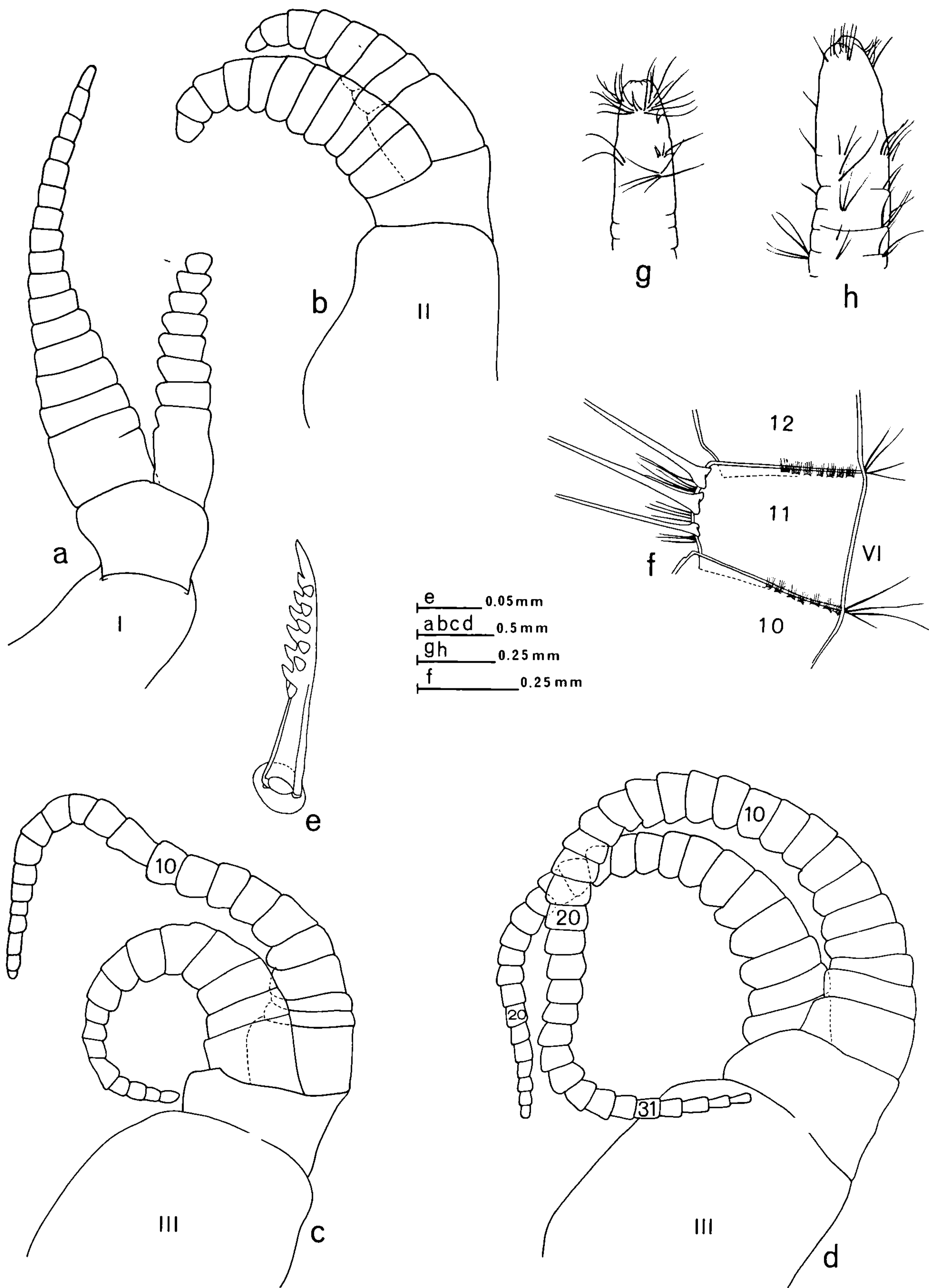

Figure 4. Thoracic appendages of *Epopella breviscutum*. a, left cirrus I; b, right cirrus II; c, right cirrus III; d, left cirrus III; e, comb seta from segment 5 of outer ramus of left cirrus III; f, intermediate segment of right outer ramus of cirrus VI; g,h. distal extremity of intromittant organ. Lectotype (26-XI-14D), b, c, f; paralectotypes, a, d, e, g-h (e,g,d = 26-XI-14C; a = 26-XI-14A; h = 2X-XI-14B).

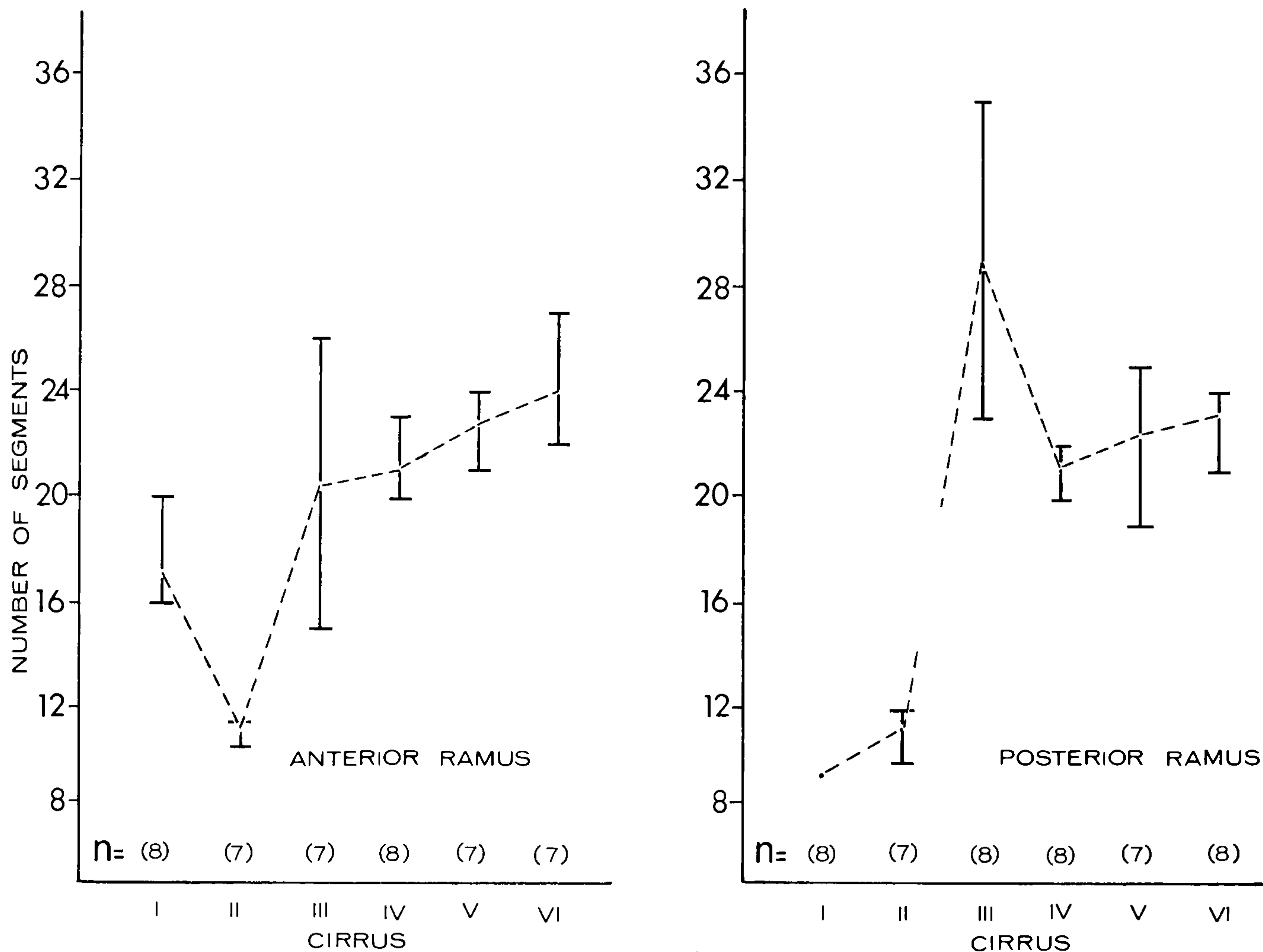

Figure 5. Graph of range (vertical line) and mean values (dotted line) for cirral counts of anterior ramus (left) and posterior ramus (right) of *Epopella breviscutum*.

bristles; distal extremity bears two large separate clusters of long setules (Fig. 4g).

Embryos in mantle cavity average 0.10×0.22 mm. Stage I nauplii in mantle cavity average 0.12×0.20 mm.

Remarks. — Broch illustrated the opercular plates and trophi of *breviscutum*, but failed to select a holotype. Because the specimen or specimens he figured are no longer available, the specimens here figured (opercular plates, figs. 2a-c, 3; trophi, figs. 3a-e, g; cirri, figs. 4b, c, f) are designated the lectotype (26-XI-14D), and the remaining specimens, of which I have seen 4, are designated paralectotypes (26-XI-14A-C, E).

DISCUSSION

Monometric shell growth, non-tubiferous and narrow or obsolete radii, and the orifice enlarged by attrition rather than diametric growth clearly establish *E. breviscutum* as a member of the tesseroporan group (Ross, 1969: 238).

The space between the inner and outer lamina in *Tetraclita* is filled with a network of continuous longitudinal septa, which in effect create longitudinal tubes. These are more or less uniform in section, and occur in rows with the smallest and shortest tubes parallel to the outer lamina. In *Tesseropora* and *Tesseroplax* there is basically but one row of these tubes. *Epopella breviscutum* lacks an inner lamina, and thus is effectively solid walled. A

THIS PAGE IS LOCKED TO FREE MEMBERS
Purchase full membership to immediately unlock this page

DELVE INTO FANTASY, MAGIC, MYTHOLOGY & FOLKLORE

Forgotten Books'
Full Membership gives
access to 797,885 ancient
and modern, fiction and
non-fiction books.

Continue

*Fair usage policy applies

tesseroporans is probably an adaptation for the rigors of the intertidal zone (cf. Paine, 1966).

There is a considerable interval between the earliest known occurrence (Recent) of the evolutionary more primitive *Epopella* and of the more complex *Tesseropora* (Oligocene). Thus the *Epopella* lineage must be significantly older than the fossil evidence indicates, a conclusion that is also suggested by the morphologically complex shell of *E. breviscutum*. Therefore, it seems probable that the origin of the tetracitids should be sought in rocks dating from the Eocene if not the Paleocene or Cretaceous.

ACKNOWLEDGMENTS

I am indebted to Dr. Torben Wolff, Universitetets Zoologiske Museum, for the extended loan of Broch's type series of this species as well as other tetracitids collected during the Th. Mortensen expeditions. Elizabeth Pope of the Australian Museum kindly searched the collections in her charge on numerous occasions for specimens, which she has made available to me. Thanks are also due Dr. William A. Newman, Scripps Institution of Oceanography, for many invaluable discussions relating to various aspects of this and earlier studies on the Tetracitidae. For comparative material and other courtesies I thank Dr. Huzio Utinomi, Seto Marine Biological Laboratory, Dr. Elizabeth J. Batham, Portobello Marine Biological Station, New Zealand, Dr. Victor A. Zullo, California Academy of Sciences, and Brian Foster, University College of North Wales.

LITERATURE CITED

- Broch, H.
1922. Papers from Dr. Th. Mortensen's Pacific Expedition 1914-1916. X. Studies on Pacific cirripeds. Vidensk. Meddel. Dansk Naturhist. foren. Copenhagen 73: 215-358.
- Darwin, C. R.
1854. A monograph on the sub-class Cirripedia, with figures of all the species. The Balanidae (or sessile cirripedes): the Verrucidae etc., etc., etc. London, Ray Society, 1-684, pls. 1-30.
- Foster, B. A.
1967a. A guide to the littoral balanomorph barnacles of New Zealand. Tuatara 15 (2): 75-86.
1967b. The early stages of some New Zealand shore barnacles. Tane 13: 33-42.
- Henry, D. P.
1957. Some littoral barnacles from the Tuamotu, Marshall, and Caroline Islands. Proc. U.S. Natl. Mus. 107 (3381): 25-38.
- Hiro, F.
1939. Studies on the Cirripedian fauna of Japan. IV. Cirripeds of Formosa (Taiwan), with some geographical and ecological remarks on the littoral forms. Mem. Coll. Sci., Kyoto Imp. Univ., ser. B, 15 (2): 245-284.
- Linzey, J. T.
1942. The balanomorph barnacles of the Kermadec Islands. Trans. Roy. Soc. New Zealand 71: 279-281.
- Moore, L. B.
1944. Some intertidal barnacles of New Zealand. Trans. Roy. Soc. New Zealand 73 (4): 315-334, pls. 46-47.
- Newman, W. A., and A. Ross
MS. Antarctic Cirripedia: A monograph based on the collections of the USNS Eltanin Expeditions. Amer. Geophys. Union, Antarctic Res. Ser., in press.
- Newman, W. A., V. A. Zullo, and S. A. Wainwright
1967. A critique on recent concepts of growth in Balanomorpha (Cirripedia: Thoracica). Crustaceana 12 (2): 167-178.
- Nilsson-Cantell, C. A.
1930. Thoracic cirripedes collected in 1925-1927. Discovery Repts. 2: 223-260.
- Paine, R. T.
1966. Function of labial spines, composition of diet, and size of certain marine gastropods. Veliger 9 (1): 17-24.
- Pilsbry, H. A.
1916. The sessile barnacles contained in the collection of the U.S. National Museum; including a monograph of the American species. Bull. U.S. Natl. Mus. 93: 1-366.

Pope, E. C.

1945. A simplified key to the sessile barnacles found on the rocks, boats, wharf piles and other installations in Port Jackson and adjacent waters. *Rec. Australian Mus.* 21 (6): 351-372, pls. 27-30.

Ross, Arnold

1965. A new cirriped from the Eocene of Georgia. *Quart. J. Florida Acad. Sci.* 28 (1): 59-67.
1969. Studies on the Tetraclitidae (Cirripedia: Thoracica): Revision of *Tetraclita*. *Trans. San Diego Soc. Nat. Hist.* 15 (15): 237-251.

Ross, A., and W. A. Newman

1967. Eocene Balanidae of Florida, including a new genus and species with a unique plan of "turtle-barnacle" organization. *Amer. Mus. Novitates* 2288: 1-21.

Stephenson, W.

1968. The intertidal acorn barnacle *Tetraclita vitiata* Darwin at Heron Island. *Univ. Queensland Pap.* 1 (3): 51-59.

Wisely, B., and R. A. P. Blick

1964. Seasonal abundance of first stage nauplii in 10 species of barnacles at Sydney. *Australian Jour. Mar. Freshwater Res.* 15 (2): 162-171.

Department of Invertebrate Paleontology, Natural History Museum, P.O. Box 1390, San Diego, California 92112.

**THE SHALLOW WATER ANOMURAN CRAB FAUNA
OF SOUTHWESTERN BAJA CALIFORNIA, MEXICO**

**JANET HAIG, THOMAS S. HOPKINS
AND THOMAS B. SCANLAND**

TRANSACTIONS

**OF THE SAN DIEGO
SOCIETY OF
NATURAL HISTORY**

VOL. 16, NO. 2

4 JUNE 1970

THE SHALLOW WATER ANOMURAN CRAB FAUNA OF SOUTHWESTERN BAJA CALIFORNIA, MEXICO

JANET HAIG, THOMAS S. HOPKINS
AND THOMAS B. SCANLAND

ABSTRACT. — Thirty-five species of anomuran crabs are reported from the 1964 "Mag Bay" Expedition, 19 of which are new records for the outer coast of southern Baja California, Mexico. A checklist and keys are appended for the 52 species of Anomura now known to inhabit this area.

RESUMEN. — Durante la Expedición "Mag Bay" en 1964, se observaron treinta y cinco especies de cangrejos anomuros, diez y nueve de ellas encontradas por primera vez, en las costas occidentales de la zona meridional de Baja California, México. Se incluye una lista y las claves correspondientes para las 52 especies de Anomuros observados hasta la fecha en aquellas regiones.

The purpose of the "Mag Bay" Expedition of 1964 was to study the maritime biota along the coast of Baja California, Mexico, from Punta San Eugenio (Punta Eugenia) to the lower entrance of Bahía Magdalena (Figs. 1, 2). Dr. Carl L. Hubbs, Scripps Institution of Oceanography, was the originator and leader of the expedition, which was supported by the Office of Naval Research. The scientific party was divided into three teams: Team 1, aboard the R/V HORIZON, was responsible for sampling in deep water; Team 2, in small craft, worked in the mangrove-estuarine environment; Team 3, aboard the Scripps vessel T-441, was responsible for "on site" fish poisonings, invertebrate and algal collecting, and otter trawling along the 20- and 40 m depth contours in the area of study.

Two of the authors (TSH and TBS) were members of Team 2, where SCUBA was used in depths of one to 30 meters. A concerted effort was made to collect decapod crustaceans and echinoderms, as well as fish. The specimens were returned to the T-441, where they were kept alive until color notes and tentative identifications could be recorded. At the conclusion of the cruise, the anomuran crabs were forwarded to the Allan Hancock Foundation for study by the senior author (JH).

Thirty-five species of Anomura were collected, of which 19 constitute new records for the outer coast of southern Baja California (Punta San Eugenio and southward) within the 40 m contour. A checklist and keys to all species known to fall within these geographical and bathymetrical limits are appended.

This report is a Contribution from the Allan Hancock Foundation, no. - 339, supported by NSF Grant GB-2039, and a Contribution from the Scripps Institution of Oceanography, supported by NSF Grant GB 2312 (to D. L. Fox).

HISTORICAL RESUME

The following anomuran crabs are presently known from the region under consideration: *Munida mexicana* (Benedict, 1902), *Dardanus sinistripes* (Rathbun, 1910), *Pleuroncodes planipes*, and *Emerita analoga* (Schmitt, 1921). In addition, Glassell (1936) reported on several porcellanids which he collected at Bahía Magdalena. These included *Petrolisthes hirtipes* (Lockington), and the new species *Orthochela pumila*, *Pisosoma erosa* (= *Megalobrachium erosum*), and *Porcellana magdalenensis* (= *Pisidia magdalenensis*). He also treated the porcellanid and hermit crabs from the Templeton Crocker Expedition of

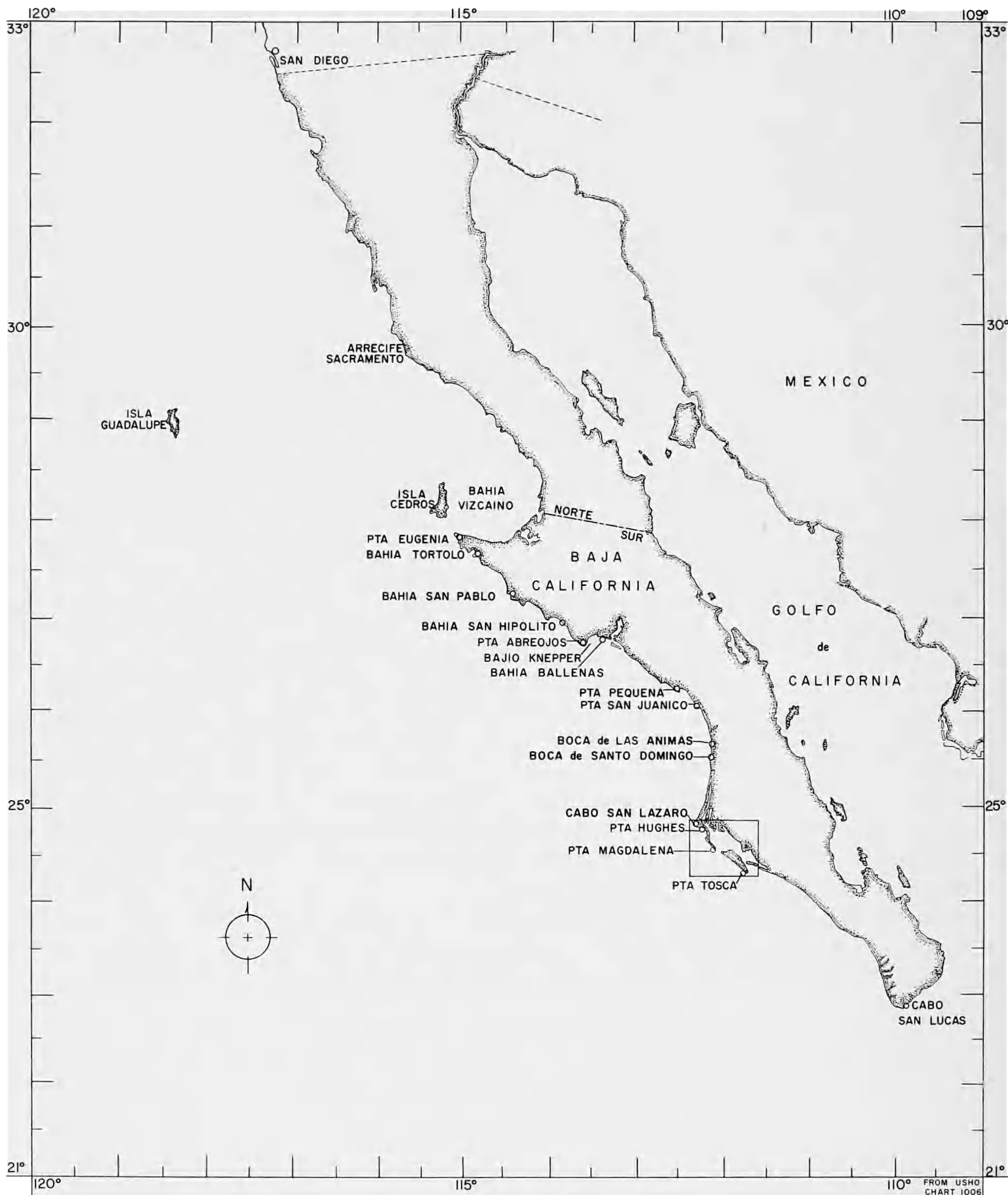

Figure 1. Map of Baja California, Mexico. Area delimited by the box on the western side of the peninsula is shown enlarged in figure 2.

1936 (Glassell, 1937a, 1937b). However, only one species comes within the scope of the present work, *Paguristes bakeri* Holmes, which was collected off Isla Cedros (Glassell, 1937b.) Schmitt (1939) listed "*Paguristes* species" from Bahía Magdalena, a form still awaiting description. To the known fauna Haig (1960) added 16 species of Porcellanidae.

THIS PAGE IS LOCKED TO FREE MEMBERS
Purchase full membership to immediately unlock this page

FORGOTTEN BOOKS

FULL MEMBERSHIP

797,885 Books!
All you can read
for only
\$8.99/month

Continue

*Fair usage policy applies



On Punta Belcher we observed that these animals are nocturnal. A search for their homesites was fruitless, although the crabs "appeared" within 17m of the camp just after dark, and could not be found after daybreak. Probably they had remained inactive in their shells along the upper tide marks during the day, and thus went unnoticed.

Six to 10 individuals were observed feeding on dead or molted *Pleuroncodes planipes* which formed windrows on the beach.

The range of this species is extended to the outer Baja California coast, and 300 km north along the outer coast.

Family DIOGENIDAE

Dardanus sinistripes (Stimpson)

Pagurus sinistripes Stimpson, 1858: 223 (*nom. nud.*); 1859: 82.

Dardanus sinistripes: Glassell, 1937b: 251.

Recorded Range. — Bahía Magdalena (Rathbun, 1910) and Isla Tiburón, Golfo de California, to Bahía de Sechura, Perú.

Material. — Off Boca de Santo Domingo; otter trawl; 40 m; 27 Jan. 1964; 1 ♀. Laguna de Santa Maria; 1.2 m; 29 Jan. 1964; 1 ♂.

Color. — "In alcohol, the carapace is buff with red markings. The chelipeds, purple and red, with the interior margins of the meri white; the teeth of the fingers white, bordered with yellow. The ambulatory legs are purple, their dactyli with dark brown setae, their meri and carpi blotched on a light ground with red" (Glassell, 1937b). There are two narrow, dark bands, one median and the other proximal, on the eyestalk.

Calcinus californiensis Bouvier

Calcinus californiensis Bouvier, 1898: 380; Glassell, 1937b: 252.

Calcinus californiensis: Chace, 1962: 627, text-figs. 5-6.

Recorded Range. — Isla San José, Golfo de California, to Acapulco, México. Isla Clipperton.

Material. — Punta Cala; 3 m; 31 Jan. 1964; 2 ♂, 1 ♀.

Roca de la Vela; 6 m; 1 Feb. 1964; 2 ♀. Inside Punta Tosca, in lagoon; 5 m; 4 Feb. 1964; 5 ♂, 2 ♀.

Color. — The coloration of this and allied species, in both live and preserved material, was discussed in some detail by Chace (1962: 628). A broad white band at the base of the cornea and the solid dark color of the dactyls of the walking legs unmistakably identify the above specimens as *Calcinus californiensis*.

Remarks. — The range of this species is extended to the outer Baja California coast, and 300 km north.

Aniculus elegans Stimpson

Aniculus elegans Stimpson, 1858: 234 (*nom. nud.*); 1859: 83; Boone, 1931: 140, text-fig. 1.

Recorded Range. — Golfo de California (exact locality not stated) to Cabo de San Francisco, Ecuador.

Material. — Outside Bahía Magdalena; 18 m; 1 Feb. 1964; 1 juv. Inside Punta Tosca, in lagoon; 5 m; 4 Feb. 1964; 1 ♀. Off Punta Redonda; 15 m; 5 Feb. 1964; 6 ♂, 5 ♀.

Color. — Carapace red, with a pink area on the posterior part of the shield. Eyestalks tan. Chelipeds pink, with red on the fingers and on the distal half of the chelae. Dactyls of walking legs dark red; other segments pink. A broad, submedian red band on the propodus, a submedian red blotch on the anterior margin of the carpus, and a smaller median blotch on the anterior margin of the merus.

Remarks. — Off Punta Redonda these hermits occurred under rocks in aggregates of

five or more. *Porcellana paguriconviva* Glassell were found in the shells of specimens collected at the same locality, an association that has not been recorded previously.

The range of this species is extended to the outer Baja California coast, and 300 km north.

Trizopagurus magnificus (Bouvier)

Clibanarius magnificus Bouvier, 1898: 378.

Clibanarius chetyrkini Boone, 1932: 29, text-fig. 8.

Trizopagurus magnificus: Forest, 1952: 4, 12, text-figs. 2, 11, 18.

Recorded Range. — Golfo de California (exact locality not stated) to Isla de la Plata, Ecuador. Archipiélago de Galápagos.

Material. — Roca de la Vela; 6 m; 1 Feb. 1964; 1 ♀. Off Punta Redonda; 15 m; 5 Feb. 1964; 1 ♀.

Color. — The species may be readily identified by the large, irregular pale blotches on a dark background which cover the carapace shield, eyestalks, chelipeds, and walking legs.

Remarks. — The range of this species is extended to the outer Baja California coast, and 300 km north.

Clibanarius panamensis Stimpson

Clibanarius panamensis Stimpson, 1858:235 (*nom nud.*); 1859: 84; Holthuis, 1954: 23, text-figs. 7-8.

Recorded Range. — Santa Rosalía, Golfo de California, to Isla de la Correa, Perú.

Material. — Laguna de Santa María; in +1 m and out of water; 29 Jan. 1964; 8 ♂, 1 ♀.

Color. — Hermits of this species may be recognized immediately by the color pattern of the walking legs, which consists of longitudinal dark and light stripes, subequal in width, on each segment.

Remarks. — The range of this species is extended to the outer Baja California coast, and 300 km north.

Isocheles pilosus (Holmes)

Holopagurus pilosus Holmes, 1900: 154; Schmitt, 1921: 127, pl. 17 fig. 2; Ricketts and Calvin, 1939: 189, pl. 39 fig. 2.

Isocheles pilosus: Forest, 1964: 294.

Recorded Range. — Off San Francisco Bay, California, to Estero de Punta Banda, outer Baja California.

Material. — Punta Abreojos, Bahía de Ballenas; +.7 m while wading; 29 Jan. 1964; 1 . 2.5 miles west of Boca de Santo Domingo; 16' otter trawl; 14-20 m; 26 Jan. 1964; 1 ♂. Outside Punta Hughes; 20 m; 30 Jan. 1964; 1 ♀ (juv.). Punta Pequeña, Bahía de San Juanico; 3 m; 8 Feb. 1964; 1 ♂, 1 juv.

Remarks. — Identification of the above specimens with *Isocheles pilosus* is tentative, pending a revision of genus *Isocheles* by J. Forest of the Muséum National d'Histoire Naturelle, Paris. Some of the material may belong to *I. pacificus* Bouvier (see Forest, 1964: 291, text-fig. 11). Neither *I. pilosus* nor *I. pacificus* has heretofore been reported from the outer coast of southern Baja California, and the range is extended 850 km south.

Paguristes bakeri Holmes

Paguristes bakeri Holmes, 1900: 152; Schmitt, 1921: 122, 124, pl. 18 figs. 2, 6; Glassell, 1937b: 243, 244.

Paguristes holmesi Glassell, 1937b: 243, 247.

Recorded Range. — Outside San Francisco Bay, California, southward along the California and outer Baja California coast (Glassell, 1937b; Parker, 1964), and in Golfo de California as far north as Punta Baja.

Material. — HORIZON Sta. A-11, 8 miles west of Punta Redonda; Isaacs-Kidd

midwater trawl, scraped on sand bottom; 106-116 m; 29 Jan. 1964; 1 juv.

Remarks. — Studies now in progress by JH indicate that *Paguristes holmesi* is a synonym of *P. bakeri* Holmes. *Paguristes bakeri* has been recovered from shallow water (generally in the northern half of its range), but it occurs more commonly in over 40 m and has been reported from depths as great as 232 m.

Paguristes ulreyi Schmitt

Paguristes ulreyi Schmitt, 1921: 123, 125, pl. 18 figs. 3-5, 7.

Paguristes occator Glassell, 1937b: 243, 244.

Recorded Range. — Monterey Bay, California, southward along the California and outer Baja California coast, and in Golfo de California as far north as Punta Gorda.

Material. — Bajío Knepper, Punta Abrejos; 17-20 m; 9 Feb. 1964; 1 ♀ ovig. Bahia de San Hipólito; 10-13 m; 9 Feb. 1964; 5♂, 3♀ ovig., 1 juv. Without data; 1♂, 2 ♀ (1 ovig.), 2 juv.

Remarks. — Examination of specimens in the collections of the Allan Hancock Foundation indicates that this species is not uncommon in the southernmost part of Golfo de California, where it occurs in deeper water than it does in higher latitudes. *Paguristes occator* Glassell seems to be a synonym.

Paguristes parvus Holmes

Paguristes parvus Holmes, 1900: 151, pl. 2 fig. 26; Schmitt, 1921: 123, 124, pl. 17 fig. 1, text-fig. 83.

Recorded Range. — Known only from White's Point near San Pedro, California.

Material. — Arrecife Sacramento; 13 m, from kelp holdfast; 25 Jan. 1964; 1♂.

Remarks. — On the basis of the above specimen, the range of *Paguristes parvus* is extended southward 550 km.

Paguristes anahuacus Glassell

Paguristes anahuacus Glassell, 1938: 421.

Recorded Range. — Reported only from Punta Peñasco, Golfo de California.

Material. — Outside Punta Hughes; 20 m; 30 Jan. 1964; 1♂. Roca de la Vela; 6 m; 1 Feb. 1964; 1♂, 1♀. Outside Isla Santa Margarita, west of Punta Tosca; 21-25 m; 3 Feb. 1964; 1♀. Off Punta Redonda; 15 m; 5 Feb. 1964; 1♂, 1♀. Bajío Knepper, Punta Abrejos; 16-20 m; 9 Feb. 1964; 11♀. Without data; 3 ♀ ovig.

Color. — Carapace shield with a broad median longitudinal orange stripe on anterior half; orange blotches on median portion of lateral margins. Proximal half of eyestalk orange; distal half bright purple, with a narrow white band at base of cornea. Antennal and antennular flagella purple. Pereiopods orange.

Remarks. — Punta Peñasco is 1000 km north of Cabo San Lucas on the mainland side of the Gulf. The range of this species is further extended to the outer coast of Baja California, and 550 km north.

Paguristes praedator Glassell

Paguristes praedator Glassell, 1937b: 243, 245.

Recorded Range. — Golfo de California, from Bahía de Santa Inés and Isla Tiburón south to Isla Isabel.

Material. — Off Boca de Santo Domingo; 16' otter trawl; 40 m; 27 Jan. 1964; 1 juv.

Remarks. — Examination of a long series of specimens in the collections of the Allan Hancock Foundation shows that this species occurs infrequently within the 40 m line; it has been most often dredged in 60 m or deeper. The range is extended to the outer Baja California coast, and 350 km north.

Paguristes, undescribed species

Paguristes species, Schmitt, 1939: 9.

Material. — Off Boca de las Ánimas; 16' otter trawl; 40 m; 27 Jan. 1964; 1♂ (juv.). Off Boca de Santo Domingo; 16' otter trawl; 40 m; 27 Jan. 1964; 2♂ (1 juv.).

Color. — Carpus of chelipeds red; chelae white with red blotches, which merge to form a transverse band about midway along each finger. Walking legs white; propodus and dactyl each with a proximal and subdistal red ring.

Remarks. — This species, which will be described and illustrated in a future report, appears to be abundant on the outer Baja California coast. The ovigerous female noted by Schmitt (1939) was collected by the HOUSTON (Presidential Cruise of 1938) in Bahía Magdalena between Punta Belcher and the anchorage, in 20-30 m.

Family PAGURIDAE

Pagurus smithi (Benedict)

Eupagurus smithi Benedict, 1892: 4.

Pagurus smithi: Glassell, 1937b: 256, 259.

Recorded Range. — Golfo de California, from Estero de Tasiota to Punta Piaxtla on the east side (Parker, 1964) and from Bahia de Santa Ines to Bahia de la Paz on the Baja California peninsula.

Material. — Off Boca de Santo Domingo; 16' otter trawl; 40 m; 27 Jan. 1964; 2 juv.

Remarks. — This species is well represented in the collections of the Allan Hancock Foundation from depths greater than 40 m; it seems to occur rarely within the 40 m contour. The range is extended 150 km south to the outer Baja California coast, 350 km north along the outer coast.

Pagurus, undescribed species (1)

Material. — Off Boca de las Animas; 16' otter trawl; 20 and 40 m; 27 Jan. 1964; 2♂, 2♀ ovig., 3 juv.

Remarks. — This small species, represented by considerable material in the collections of the Allan Hancock Foundation, will be described elsewhere. It belongs to the group of *Pagurus* species having multispinulate eyescales.

Pagurus lepidus (Bouvier)

Eupagurus lepidus Bouvier, 1898: 381.

Pagurus lepidus: Glassell, 1937b: 256.

?*Pagurus lepidus*: Chace, 1962: 623, text-fig. 2.

Recorded Range. — Golfo de California, from Puerto Peñasco to El Mogote. ?Isla Clipperton.

Material. — Off Boca de Santo Domingo; 16' otter trawl; 40 m; 27 Jan. 1964; 1♂, 1♀ ovig. Outside Punta Hughes; 20 m; 30 Jan. 1964; 4♂, 1♀ ovig. Punta Cala; 3 m; 31 Jan. 1964; 1 juv. Outside Bahía Magdalena; 20 m; 1 Feb. 1964; 2♂. Isla Santa Margarita; 16' otter trawl; 20 m; 4 Feb. 1964; 1♂, 1♀. Punta Redonda; 15 m; 5 Feb. 1964; 1♂. Punta Pequeña, Bahía de San Juanico; 3 m; 8 Feb. 1964; 2♂, 1♀. Bahía de San Hipolito; 10-13 m; 9 Feb. 1964; 3♂, 2♀ (1 ovig.). Bajío Knepper, Punta Abrejos; 16-20 m; 9 Feb. 1964; 7♂, 6♀ (3 ovig.), 1 juv.

Color. — Most of the specimens showed a color pattern on the walking legs like that in Chace's illustration (1962, text-fig. 2). In a few individuals the longitudinal stripes were less well developed, and pigment was concentrated at the proximal end of the dactyl to form a narrow ring. Current studies by JH show that there is a series of eastern Pacific *Pagurus* species closely allied to *P. lepidus* and probably confused under that name; this

problem, as it concerns the "Mag Bay" material, will be discussed elsewhere.

Remarks. — The range of this species is extended to the outer Baja California coast and 550 km north.

Pagurus galapagensis (Boone), new combination

Nympagurus galapagensis Boone, 1932: 17, text-fig. 5.

Recorded Range. — Known only from Bahia de Gardner, Isla Hood (or Espanola), Archipiélago de Galapagos.

Material. — Roca de la Vela; 6 m; 1 Feb. 1964; 1♂, 1♀.

Color. — Hand under dense tomentum pale orange, with tubercles of darker orange; fingers white with an intense orange spot at tip of each. Walking legs with longitudinal orange stripes, overlying a broad median orange ring on carpus and propodus and two rings on dactyl.

Remarks. — Studies currently in progress by JH indicate that this species occurs throughout the Panamic faunal province. Examination of the holotype (Cat. No. 12238 in the American Museum of Natural History, New York) showed that it falls within *Pagurus* as that genus is currently (although too broadly) defined. Its affinities are with a natural group of *Pagurus* species recently discussed and designated as "groupe *miamensis*" (Forest and Saint Laurent, 1968: 116).

Pagurus, undescribed species (2)

Material. — HORIZON Sta. A-11; 8 miles west of Punta Redonda; Issacs-Kidd midwater trawl scraped on sand bottom; 106-116 m; 29 Jan. 1964; 2♂, 2♀(1 ovig.).

Remarks. — This species has been collected on several occasions around the southern part of the Baja California peninsula, never in less than 104 m. It will be described in a future report.

Pylopagurus californiensis (Benedict), new combination

Eupagurus californiensis Benedict, 1892: 21; Faxon, 1895: 55, pl. 11 figs. 2, 2a-f.

Pagurus californiensis: Glassell, 1937b: 256, 257.

Recorded Range. — Santa Catalina Island, California, and Cabo Tepoca, Golfo de California, to Darién, Panamá. Isla del Coco; Archipiélago de Galápagos.

Material. — Outside Bahía Magdalena; 20 m; 1 Feb. 1964; 1♂. Without data; 1♂.

Color. — Carapace shield with longitudinal dark and light streaks anteriorly; solid color toward anterolateral margins. Eyestalks orange, with broad white ring submedially. Basal antennal article and acicle orange; acicle darker along outer edge. Manus and fingers of major cheliped with diffused orange; raised granular areas white; outer margin with alternating white and orange spots. Carpus solid dark orange except for narrow longitudinal white area along inner margin, and a few very small white spots on dorsal surface. Merus mostly orange, with small white spots. Manus of minor cheliped with a large irregular orange area on dorsal surface; a longitudinal orange stripe, not continued far onto pollex, along outer edge. Carpus with thin orange stripe along each dorsolateral margin; a broader stripe midway along both outer and inner lateral surfaces; another along ventral surface. Merus of walking legs with two longitudinal red stripes on outer surface, one on upper margin, and two on inner surface; carpus with three on outer surface, one on dorsal margin, and two on inner surface; propodus with two on outer surface, one on dorsal margin, one on ventral margin, and two on inner surface; dactyl with one each on outer surface, dorsal margin, and inner surface. With the exception of those on inner surface of merus, which are incomplete, none of these stripes are interrupted. All these stripes are imposed on broad transverse bands of white and pale orange.

Remarks. — This species, and the two that follow, have not been recognized as members of the genus *Pylopagurus* and were consequently not included in Walton's (1954) review of the eastern Pacific forms of that genus. The shape of the major chela and the presence of paired first pleopods in the female place all three species with *Pylopagurus*.

Although there are no published records of *Pylopagurus californiensis* along the outer coast of Baja California, the distribution between Santa Catalina Island and Bahía Magdalena is not interrupted; specimens from many intermediate localities are in the collections of the Allan Hancock Foundation.

Pylopagurus venustus (Bouvier), new combination

Eupagurus venustus Bouvier, 1898: 383.

Recorded Range. — Known only from Bahía de la Paz, Golfo de California.

Material. — Outside Punta Hughes; 20 m; 30 Jan. 1964; 1 ♀ ovig.

Color. — Ground color white and pale orange, with darker shades of orange-brown. Carapace pale brown, with two irregular small brown blotches anteriorly. A narrow band of pale orange on eyestalks at about level of tip of eyescales. Major chela with irregular diffused brown except on fingers and distal half of lateral expansion. A few small dots on fingers. Other segments of major cheliped with irregular blotches; darker on lateral surfaces. Minor cheliped with two broad bands on manus, one on carpus, one on hand and basal part of fingers; these bands are brown, edged in darker brown, and with an irregular, sinuous outline. Walking legs with similar, sinuous-margined bands: two on merus, a distal one on carpus, a median one on propodus, and a proximal one on dactyl. Non-banded areas white and very pale orange.

Remarks. — The characteristic broad bands with sinuous margins which decorate the walking legs unfortunately fade rapidly in alcohol; specimens can then best be distinguished from faded specimens of *Pylopagurus californiensis* by the carpus of the right cheliped, which in *P. venustus* is covered dorsally by numerous forward-directed spinules.

The range is extended 150 km south to the outer Baja California coast, and 300 km north along the outer coast.

Pylopagurus roseus (Benedict), new combination

Eupagurus roseus Benedict, 1892: 22.

Recorded Range. — The type locality was given only as "Gulf of California" by Benedict. According to the accompanying label, however, the holotype and only known specimen was collected off Bahía Adair, in the northernmost part of the Gulf, 1000 km north of Cabo San Lucas.

Material. — North of Punta Belcher; 8 m; 2 Feb. 1964; 1 ♂, 1 ♀. Punta Cala; 5 m; 6 Feb. 1964; 1 ♂, 2 ♀ ovig.

Color. — Eyestalks white, with broad orange band at about level of tips of eyescales. Chelipeds orange-brown; carpus with many small white spots. Walking legs orange-brown; merus with large white blotches; propodus and dactyl each with a broad, subdistal white ring and a distal narrower one.

Remarks. — The range is extended to the outer Baja California coast, and 300 km north.

Pylopagurus diegensis Scanland and Hopkins

Pylopagurus diegensis Scanland and Hopkins, 1969: 257, fig. 1.

Material. — Uncertain locality data; 1 ♀.

Remarks. — This species has been collected at several localities in southern California and northern Baja California.

Family GALATHEIDAE

Pleuroncodes planipes Stimpson

Pleuroncodes planipes Stimpson, 1860: 245; Schmitt, 1921: 163, pl. 31 fig. 2.

Recorded Range. — Monterey Bay, California, and northern Golfo de California, to about 250 km south of Cabo San Lucas.

Material. — These crabs were very abundant at the surface just inside Punta Entrada and many were collected during the expedition but were not critically examined. Large windrows of either dead or molted individuals littered the beach just south of Punta Belcher and were fed on by *Coenobita compressus*.

Remarks. — *Pleuroncodes planipes* normally ranges from Baja California southward; Radovich (1961: 49-50) discussed the history of its occurrence off the California coast during periods of high ocean temperatures. Crabs of this species are pelagic, frequently occurring near the surface in swarms several miles wide, and may be washed ashore in great numbers; at other times they are not visible near the surface, but may be taken by mid-depth or bottom trawling (Radovich 1961: 50). Swarming and mass strandings on the outer coast of southern Baja California were noted by several authors, including Matthews (1932: 472), Steinbeck and Ricketts (1941: 455), and Radovich (1961: 50).

Family PORCELLANIDAE

Orthochela pumila Glassell

Orthochela pumila Glassell, 1936: 296, pl. 21 fig. 1; Haig, 1960: 14, pl. 18 fig. 1, text-fig. 1.

Recorded Range. — Bahía Magdalena, outer Baja California, and Mazatlan, Mexico, to Bahía de Caraquez, Ecuador.

Material. — Inside Punta Hughes; 3-8 m; 29 Jan. 1964; 19♂, 21♀ (18 ovig.), 1 juv. Near Mexican naval establishment at Puerto Cortez, northwest end of Bahía de Almejas; 1.5 m; 5 Feb. 1964; 1 . Punta Pequeña, Bahía de San Juanico; 3 m; 9 Feb. 1964; 7♂, 6♀ (4 ovig.). Bahía de San Hipólito; 10-13 m; 9 Feb. 1964; 4♂, 3♀ ovig.

Color. — The specimens collected and described by Glassell were yellow, with red striations on the carapace and some red areas on the chelae; they were found clinging to yellow gorgonian corals. During the "Mag Bay" expedition collectors took some yellow individuals with red markings; other specimens were solid purple; blotched red and yellow; brown with white spots; and white with rust-colored spots. Each specimen perfectly matched the color of the gorgonian coral upon which it was found.

Remarks. — Several other porcellanids were found associated with *Orthochela pumila* on gorgonians. Unlike *Orthochela*, however, they are not obligatory commensals but take shelter in a variety of situations.

Orthochela pumila was previously collected by Glassell at Bahía Magdalena, the type locality. On the basis of specimens collected during this expedition, the range of the species is extended northward along the outer Baja California coast 300 km to Bahía de San Hipólito.

Petrolisthes sanfelipensis Glassell

Petrolisthes sanfelipensis Glassell, 1936: 281; Haig, 1960: 24, 30, pl. 20 fig. 3.

Recorded Range. — Bahía de San Juanico to Bahía Magdalena, outer Baja California (Haig, 1960); Punta Peñasco to Guaymas, Golfo de California.

Material. — Outside Punta Hughes; 20 m; 30 Jan. 1964; 1♂ (juv.). Near Mexican naval establishment at Puerto Cortez, northwest end of Bahía de Almejas; 1.5 m; 5 Feb. 1964; 1♀. Punta Pequeña, Bahía de San Juanico; 3 m; 9 Feb. 1964; 1♂ (juv.).

Remarks. — The specimen from Punta Pequeña was taken from a gorgonian. The

THIS PAGE IS LOCKED TO FREE MEMBERS
Purchase full membership to immediately unlock this page

DELVE INTO FANTASY, MAGIC, MYTHOLOGY & FOLKLORE

Forgotten Books'
Full Membership gives
access to 797,885 ancient
and modern, fiction and
non-fiction books.

Continue

*Fair usage policy applies

extended northward from Bahía de Santa Maria 150 km to Bahía de San Juanico.

Porcellana paguriconviva Glassell

Porcellana paguriconviva Glassell, 1936: 293; Haig, 1960: 198, 203, pl. 38 fig. 1, text-fig. 9 (3).

Recorded Range. — Bahía Magdalena, outer Baja California (Haig, 1960), and Punta Peñasco, Golfo de California, to Islas Toboga and Taboguilla, Panamá (Haig, 1962).

Material. — Off Punta Redonda; 15 m; 5 Feb. 1964; 9♂, 4♀.

Color. — Ground color in life bright lavender, with uniform longitudinal stripes of bright orange. Chelipeds bright lavender; legs with a white spot on propodus. Ventral side iridescent, pinkish white; longitudinal stripes on carapace continued on first three segments of abdomen (Glassell, 1936).

Remarks. — The specimens were found living in shells in association with *Aniculus elegans* Stimpson. *Porcellana paguriconviva* was previously reported in association with two other large hermits, *Petrochirus californiensis* Bouvier and *Paguristes digueti* Bouvier.

Pisidia magdalenensis (Glassell)

Porcellana magdalenensis Glassell, 1936: 295; 1938: 431, pl. 32.

Pisidia magdalenensis: Haig, 1960: 209, pl. 38 fig. 4, text-fig. 10.

Recorded Range. — Bahía de Santa Maria, outer Baja California (Glassell, 1936), to Bahía de Santa Elena, Ecuador. Apparently absent from Golfo de California.

Material. — Inside Punta Hughes; 6 m; 29 Jan. 1964; 3♂, 2♀. Outside Punta Hughes; 20 m; 30 Jan. 1964; 1♂, 1♀ ovig. Off Isla Santa Margarita; otter trawl; 20 m; 4 Feb. 1964; 1♂.

Remarks. — The specimens collected inside Punta Hughes were associated with yellow gorgonian corals.

Megalobrachium garthi Haig

Megalobrachium garthi Haig, 1957: 39, pl. 10; 1960: 213, 220, pl. 16 fig. 7, pl. 39 fig. 4.

Recorded Range. — Isla Turner, Golfo de California, to Puerto Utría, Colombia.

Material. — Inside Punta Hughes; 6 m; 29 Jan. 1964; 1♂. Outside Bahía Magdalena; 20 m; 1 Feb. 1964; 1♂. Inside Punta Tosca, in lagoon; 5 m; 4 Feb. 1964; 1♂.

Remarks. — The specimen from Punta Hughes was taken from a yellow gorgonian, and the one from Punta Tosca from a sponge. The range of this species is extended to the outer coast of Baja California, and 300 km north.

Megalobrachium tuberculipes (Lockington)

Pachycheles tuberculipes Lockington, 1878: 396, 404.

Pisonella tuberculipes: Glassell, 1938: 437, 440, pl. 34 fig. 1.

Megalobrachium tuberculipes: Haig, 1960: 213, 227, pl. 16 fig. 11, pl. 40 fig. 4.

Recorded Range. — Punta Peñasco and San Felipe, Golfo de California, to Bahía de Santa Elena, Ecuador.

Material. — Inside Punta Hughes; 6 m; 29 Jan. 1964: 1♂, 1♀. Inside Punta Tosca, in lagoon; 5 m; 4 Feb. 1964; 2♂. Bahía de San Hipólito; 10-13 m; 9 Feb. 1964; 1♀.

Remarks. — Specimens were taken from a yellow gorgonian at Punta Hughes and from sponge at Punta Tosca.

The range of this species is extended to the outer coast of Baja California, and 550 km north.

APPENDIX

The checklist and keys which follow include all species of anomuran crabs known to occur on the west coast of Baja California from Punta San Eugenio (Punta Eugenia) southward, in depths of 40 m or less. Nineteen of these species are included as a result of the expedition reported upon in the first part of this paper; 26 species on the basis of published records; and 7 species on the strength of records, as yet unpublished, in the Allan Hancock Foundation of the University of Southern California.

CHECKLIST OF ANOMURAN CRABS FROM
SOUTHWESTERN BAJA CALIFORNIA, MEXICO

Unpublished records are marked with an asterisk (*)

Family HIPPIDAE

Emerita analoga (Stimpson)

Hippa analoga Stimpson, 1857: 85. *Emerita analoga*: Schmitt, 1921: 173, pl. 31 fig. 5, text-fig. 110; 1935: 214, 216, text-figs. 75a, b. Range: Alaska to southwest Baja California; also Perú and Chile. Bahía de San Bartolomé (Schmitt 1921); Bahía Magdalena (Schmitt 1935).

Family ALBUNEIDAE

Lepidopa myops Stimpson

Lepidops myops Stimpson, 1860: 241. *Lepidopa myops*: Schmitt, 1921: 172, pl. 31 fig. 4. Range: Southern California to Cabo de San Lucas, Golfo de California. *Bahía de Santa María.

Family COENOBITIDAE

Coenobita compressus H. Milne Edwards. See p.15 .

Family DIOGENIDAE

Dardanus sinistripes (Stimpson). See p.16 .

Calcinus californiensis Bouvier. See p.16 .

Petrochirus californiensis Bouvier.

Petrochirus californiensis Bouvier, 1895: 6. Glassell, 1937b: 251. Range: northern Golfo de California to Ecuador. *Bahía de Santa María.

Aniculus elegans Stimpson. See p.16 .

Trizopagurus magnificus (Bouvier). See p.17 .

Clibanarius panamensis Stimpson. See p.17 .

Isocheles sp. See p.17 .

Paguristes bakeri Holmes. See p.17 .

Paguristes ulreyi Schmitt. See p.18 .

Paguristes digueti Bouvier

Paguristes digueti Bouvier, 1893: 18, text-fig. 1-4. Glassell, 1937b: 243. Range: Golfo de California. *Bahía de Santa María; *Bahía Magdalena.

Paguristes anahuacus Glassell. See p.18 .

Paguristes praedator Glassell. See p.18 .

Paguristes, undescribed species. See p.19 .

Family PAGURIDAE

Pagurus gladius (Benedict)

Eupagurus gladius Benedict, 1892: 7. *Pagurus gladius*: Glassell, 1937b: 256, 257. Range: Golfo de California to Ecuador. *Bahía de Santa María; *Bahía Magdalena; *Punta Tosca.

Pagurus smithi (Benedict). See p.19 .

Pagurus, undescribed species (1). See p.19 .

Pagurus lepidus (Bouvier). See p.19 .

Pagurus galapagensis (Boone). See p.20 .

Pagurus samuelis (Stimpson)

Eupagurus samuelis Stimpson, 1857: 86. *Pagurus samuelis*: Schmitt, 1921: 129, 139, pl. 16 figs. 2-3, text-fig. 90. Range: Northern California to northwest Baja California. *Punta San Eugenio; *Punta San Bartolome; *Bahía de Tortuga; *Punta Asunción; *Punta Abreojos.

Pylopagurus californiensis (Benedict). See p.20 .

Pylopagurus venustus (Bouvier). See p.21 .

Pylopagurus roseus (Benedict). See p.21 .

Family GALATHEIDAE

Munida mexicana Benedict

Munida mexicana Benedict, 1902: 251, 264, text-fig. 13. Range: Northern Golfo de California to Archipiélago de Galápagos. Bahía de Santa María (Benedict).

Munida refulgens Faxon

Munida refulgens Faxon, 1893: 177; 1895: 75, pl. 17. Range: Southern Golfo de California to Panama. *Bahía Magdalena.

Munida tenella Benedict

Munida tenella Benedict, 1902: 252, 274, text-fig. 20. Range: Golfo de California. *Bahía Magdalena.

Pleuroncodes planipes Stimpson. See p. 22.

Family PORCELLANIDAE

Orthochela pumila Glassell. See p. 22.

Petrolisthes sanfelipensis Glassell. See p. 22.

Petrolisthes edwardsii (Saussure)

Porcellana edwardsii Saussure, 1853: 366, pl. 12 fig. 3. *Petrolisthes edwardsii*: Haig, 1960: 24, 33, pl. 21. Range: Southwest Baja California and southern Golfo de California to Ecuador. Bahía de Santa María; Bahía Magdalena (Haig).

Petrolisthes hirtipes Lockington

Petrolisthes hirtipes Lockington, 1878: 395, 397. Glassell, 1936: 284. Haig, 1960: 26, 60, pl. 24 fig. 3. Range: Golfo de California and southwest Baja California. Bahía Magdalena (Glassell).

Petrolisthes manimaculis Glassell

Petrolisthes manimaculis Glassell, 1945: 223, text-fig. 1. Haig, 1960: 28, 77, pl. 27 fig. 1. Range: Northern California to southwest Baja California. Punta San Eugenio (Haig).

Petrolisthes gracilis Stimpson

Petrolisthes gracilis Stimpson, 1858: 227 (*nom. nud.*); 1859: 74. Haig, 1960: 28, 79, pl. 27 fig. 2. Range: Northern Golfo de California to southern Mexico. Bahía de Santa María (Haig).

Petrolisthes cabrilloi Glassell

Petrolisthes cabrilla Glassell, 1945: 225, text-fig. 4. *Petrolisthes cabrilloi*: Haig, 1960: 28, 88, pl. 26 fig. 3. Range: Central California to southwest Baja California. Punta San Eugenio; Punta San Bartolomé; Punta Asunción; Punta Abreojos; Bahía de San Juanico; Bahía Magdalena (Haig).

Petrolisthes crenulatus Lockington

Petrolisthes crenulatus Lockington, 1878: 395, 398. Haig, 1960: 27, 110, pl. 23 fig. 4. Range: Golfo de California and southwest Baja California. Bahía Magdalena (Haig).

Petrolisthes hians Nobili. See p. 23.

Pachycheles marcortezensis Glassell. See p. 23.

Pachycheles spinidactylus Haig

Pachycheles spinidactylus Haig, 1957: 31, pl. 7; 1960: 134, 153, pl. 33 fig. 2. Range: Southwest Baja California and southern Golfo de California to Colombia. Bahía de Santa María (Haig, 1960).

Pachycheles panamensis Faxon. See p. 23.

Pachycheles pubescens Holmes. See p. 23.

Pachycheles rudis Stimpson

Pachycheles rudis Stimpson, 1858: 228 (*nom. nud.*); 1859: 76, pl. 1 fig. 5. Haig, 1960: 133, 170, pl. 34 fig. 1. Range: Alaska to southwest Baja California. Punta San Bartolomé; Bahía Magdalena (Haig).

Pachycheles holosericus Schmitt. See p. 23.

Euceramus transversilineatus (Lockington)

Porcellana transversilineata Lockington, 1878: 396, 405. *Euceramus transversilineatus*: Glassell; 1938: 426, pl. 30. Haig, 1960: 188, 190, pl. 36 fig. 2, text-fig. 7(2). Range: Northern Golfo de California to Panama. Bahía de Santa María; Bahía Magdalena (Haig).

Porcellana cancrisocialis Glassell. See p. 23.

Porcellana paguriconviva Glassell. See p. 24.

Pisidia magdalenensis (Glassell). See p. 24.

Megalobrachium garthi Haig. See p. 24.

Megalobrachium erosum (Glassell)

Pisosoma erosa Glassell, 1936: 289. *Megalobrachium erosum*: Haig, 1960: 213, 222, pl. 16 fig. 8, pl. 40 fig. 2. Range: Golfo de California and southwest Baja California. Punta Malarrimo; Bahía de San Juanico (Haig). Bahía Magdalena (Glassell).

Megalobrachium tuberculipes (Lockington). See p. 24.

Polyonyx quadriungulatus Glassell

Polyonyx quadriungulatus Glassell, 1935: 93, pl. 9. Haig, 1960: 233, 236, pl. 41 fig. 2, text-fig. 12(1). Range: Southern California to southwest Baja California. Punta San Eugenio (Haig).

KEYS TO ANOMURAN CRABS KNOWN FROM
SOUTHWESTERN BAJA CALIFORNIA, MEXICO

Identifications made with these keys should be considered tentative until specimens can be checked against descriptions and illustrations. The two sand crabs falling within the scope of our report were dealt with by Schmitt (1921). The hermit crabs of the eastern Pacific are currently being revised, but published information available at this writing is widely scattered and in some cases inadequate; a number of references are given in the preceding sections of this paper. For the Galatheidae, *Pleuroncodes planipes* was treated by Schmitt (1921), and descriptions and illustrations of the remaining species are found in either Faxon (1895) or Benedict (1902). The eastern Pacific Porcellanidae were monographed recently by Haig (1960).

Sand Crabs

- 1a. Carapace suboval; first pair of legs simple: HIPPIDAE *Emerita analoga*
1b. Carapace subquadrangular; first pair of legs subchelate: ALBUNEIDAE *Lepidopa myops*

Hermit Crabs

- 1a. Antennular peduncles several times length of eyestalks; antennular flagellum compressed and truncated at tip: COENOBITIDAE *Coenobita compressus*
1b. Antennular peduncle less than twice length of eyestalks; antennular flagellum ending in a filament 2
2a. Outer maxillipeds approximated at their bases; chelipeds equal or subequal in size, or left cheliped larger than right (in *Petrochirus*, right larger than left): DIOGENIDAE 3
2b. Outer maxillipeds widely separated at their bases; right cheliped always larger than left: PAGURIDAE 15
3a. Chelipeds markedly unequal in size and form 4
3b. Chelipeds equal or subequal in size and form 6
4a. Right cheliped larger than left *Petrochirus californiensis*
4b. Left cheliped larger than right ↘
5a. Major chela smooth; fingertips calcareous *Calcinus californiensis*
5b. Major chela tuberculate; fingertips corneous and dark *Dardanus sinistripes*
6a. No paired abdominal appendages in either sex /
6b. Paired pleopods present on first and second abdominal segments of male, and usually on first abdominal segment of female 10
7a. Fingertips acuminate; antennal flagella heavily setose *Isocheles* sp.
7b. Fingertips spooned or hoof-shaped; antennal flagella nude or sparsely setose ♂
8a. Chelipeds and walking legs with strong, grooved rings *Aniculus elegans*
8b. No such rings on legs ↘
9a. Fingers open horizontally; no white spots on chelae; walking legs with longitudinal dark and light stripes *Clibanarius panamensis*
9b. Fingers open obliquely; chelae and walking legs with large white spots *Trizopagurus magnificus*
10a. Fingertips acuminate; rostrum scarcely developed, broadly rounded; no paired pleopods in females *Paguristes*, undescribed sp.
10b. Fingertips spooned; rostrum a well-developed, acute projection; females with a pair of pleopods 11
11a. Rostrum long, acuminate, extending well between eyescales 12
11b. Rostrum broad, well-produced but falling short of or barely reaching base of eyescales 13
12a. Chelae narrow, covered with dense tomentum; eyestalks and antennae blue *Paguristes anahuacus*
12b. Chelae very broad, not tomentose; eyestalks and antennae not blue *Paguristes digueti*
13a. Eyescales with margins entire; in adults, spines on chelipeds not densely pigmented *Paguristes praedator*
13b. Eyescales toothed; in adults, spines on chelipeds densely pigmented 14
14a. Antennal flagellum with very long hairs on lower surface; rostrum extending beyond lateral frontal lobes *Paguristes ulreyi*
14b. Antennal flagellum with short hairs on lower surface; rostrum about equal in length to lateral frontal lobes *Paguristes bakeri*
15a. Major chela narrow, not forming an operculum; no paired pleopods in female 16
15b. Major chela broad, forming an operculum; female with a pair of pleopods 21
16a. Eyescales with 2 or more spines 17
16b. Eyescales with a single spine 18
17a. Tip of eyescale rounded and bearing 2 or 3 spines *Pagurus*, undescribed sp.
17b. Tip of eyescale truncate and bearing 4 spines *Pagurus lepidus*
18a. Carapace shield wider than long; eyestalks greatly expanded distally 19
18b. Carapace shield longer than wide; eyestalks not greatly expanded distally 20

- 19a. Major chela granulate on outer margin, about 2½-3 times as long as wide, narrower than carpus except at base of fingers *Pagurus gladius*
- 19b. Major chela with sharp teeth on outer margin, about twice as long as wide and about as wide as carpus *Pagurus smithi*
- 20a. Major chela with a thick fringe of hairs on margins, its dorsal surface tomentose and spiny *Pagurus galapagensis*
- 20b. Major chela not hairy, its dorsal surface granulose *Pagurus samuelis*
- 21a. Inner margin of major chela not expanded; no longitudinal ridge on movable finger *Pylopagurus roseus*
- 21b. Inner margin of major chela usually expanded laterally; movable finger with a longitudinal ridge 22
- 22a. Carpus of major cheliped nearly smooth; walking legs with longitudinal stripes overlying diffuse broad bands *Pylopagurus californiensis*
- 22b. Carpus of major cheliped with small, forward-directed spines covering its dorsal surface; walking legs with broad bands whose margins are sinuous and sharply defined *Pylopagurus venustus*

Galatheid Crabs

- 1a. Sides of carapace greatly swollen and visible in dorsal view; chelipeds and walking legs with a thick fringe of long, fine hairs on margins. Often pelagic *Pleuroncodes planipes*
- 1b. Sides of carapace not visible in dorsal view; no thick fringe of hairs on chelipeds and walking legs. Bottom living 4
- 2a. Second, third, and fourth segments of abdomen armed with spines *Munida tenella*
- 2b. Abdomen unarmed 5
- 3a. Fingers about as long as, or shorter than palm; rostrum with several lateral spines near its apex *Munida refulgens*
- 3b. Fingers much longer than palm; rostrum without spines at apex *Munida mexicana*

Porcelain Crabs

- 1a. Carapace nearly or quite half again as long as broad 2
- 1b. Carapace scarcely or not at all longer than broad 3
- 2a. Carapace and chelipeds nearly smooth, without hairs; lateral margins of carapace with a series of about 12-15 minute, close-set spinules *Orthochela pumila*
- 2b. Carapace and chelipeds rugose, with long, scattered hairs; no marginal spinules on carapace posterior to epibranchial spine *Euceramus transversilineatus*
- 3a. Movable segments of antennal peduncle with free access to orbit 4
- 3b. Movable segments of antennal peduncle separated from orbit by a broad projection of basal segment 17
- 4a. Side walls of carapace entire; chelipeds flattened, subequal 5
- 4b. Posterior portion of side walls of carapace separated by membranous interspace from anterior portion; chelipeds thick, robust, one distinctly larger than the other 12
- 5a. Carapace with transverse striations; a row of spines on anterior margin of merus of walking legs 6
- 5b. Carapace not transversely striate; anterior margin of merus of walking legs unarmed 7
- 6a. Carapace with groups of spines on dorsal surface, and a row of spines on lateral margins posterior to epibranchial spine *Petrolisthes sanfelipensis*
- 6b. No spines on dorsal surface of carapace, nor on lateral margins posterior to epibranchial spine *Petrolisthes edwardsii*
- 7a. Carpus of chelipeds armed on anterior margin with strong teeth or tubercles 8
- 7b. Carpus not armed with strong teeth or tubercles 10
- 8a. Carpus of chelipeds with wide-set conical tubercles on anterior margin; chela with a thick fringe of hair on outer margin *Petrolisthes hirtipes*
- 8b. Carpus with strong teeth on anterior margin; chela without a thick fringe of hairs 7
- 9a. Telson 5-plated; outer orbital angle produced into a distinct tooth *Petrolisthes hians*
- 9b. Telson 7-plated; outer orbital angle not strongly produced *Petrolisthes crenulatus*
- 10a. Carpus of cheliped about twice as long as wide, a lobe occupying proximal ¼ of its anterior margin *Petrolisthes cabrilloi*
- 10b. Carpus more than twice as long as wide, its margins subparallel 11
- 11a. Carapace nearly smooth posteriorly, often granular anteriorly; merus of walking legs with a fringe of hairs on anterior margin *Petrolisthes manimaculis*
- 11b. Carapace nearly smooth anteriorly as well as posteriorly; merus of walking legs nude or with only traces of hair *Petrolisthes gracilis*
- 12a. Front with a distinct tuft of hairs 13
- 12b. Hairs sometimes present on frontal area, but not forming a distinct tuft 16

- 13a. Manus with a large granulate protuberance at base of pollex; telson 5-plated in both sexes; males with a pair of pleopods; chelipeds with either long, scattered hairs or short, close-set hairs 14
- 13b. No distinct protuberance on manus at base of pollex; telson 7-plated in males, 7- or 5-plated in females; male pleopods present or absent; chelipeds with both long, scattered hairs and short, close-set hairs 15
- 14a. Carpus of chelipeds with a broad triangular lobe; chelipeds with long, scattered hairs *Pachycheles rudis*
- 14b. Carpus with a broad, serrate-edged lobe; chelipeds with short, close-set hairs . . . *Pachycheles holosericus*
- 15a. Carpus of chelipeds with a broad lobe cut into 3 or 4 uneven, serrate teeth; males with a pair of pleopods *Pachycheles pubescens*
- 15b. Carpus armed with 3 (rarely 4) spine-tipped teeth; no pleopods in males *Pachycheles spinidactylus*
- 16a. Carpus of chelipeds with 2 broad teeth; telson 7-plated; males with a pair of pleopods *Pachycheles panamensis*
- 16b. Carpus with 3-5 narrow teeth; telson 5-plated; no pleopods in males *Pachycheles marcortezensis*
- 17a. Carapace broader than long; dactyl of walking legs with 4 fixed spines *Polyonyx quadriungulatus*
- 17b. Carapace not broader than long; dactyl of walking legs with a single terminal claw and several movable spinules 18
- 18a. Front prominent, strongly tridentate or trilobate in dorsal view 19
- 18b. Front deflexed, appearing rounded or faintly trilobate in dorsal view 21
- 19a. Lateral margins of carapace unarmed posterior to epibranchial angle 20
- 19b. Lateral margins of carapace with minute spinules *Pisidia magdalenensis*
- 20a. Epibranchial angle with 2 or 3 spinules; frontal teeth pointed at tips *Porcellana cancrisocialis*
- 20b. Epibranchial angle unarmed; frontal teeth rounded at tips *Porcellana paguriconviva*
- 21a. Telson of abdomen 7-plated *Megalobrachium erosum*
- 21b. Telson 5-plated 22
- 22a. Carapace, chelipeds, and walking legs covered with small, shallow pits *Megalobrachium garthi*
- 22b. Carapace, chelipeds, and walking legs tuberculate *Megalobrachium tuberculipes*

REFERENCES

Benedict, J. E.

1892. Preliminary descriptions of thirty-seven new species of hermit crabs of the genus *Eupagurus* in the U.S. National Museum. Proc. U.S. Natl. Mus. 15: 1-26.
1902. Descriptions of a new genus and forty-six new species of crustaceans of the family Galatheidæ, with a list of the known marine species. Proc. U.S. Natl. Mus. 26: 243-334.

Boone, L.

1931. A collection of anomuran and macruran Crustacea from the Bay of Panama and the fresh waters of the Canal Zone. Bull. Amer. Mus. Nat. Hist. 63: 137-189.
1932. The littoral crustacean fauna of the Galapagos Islands. Par II. Anomura. Zoologica 14: 1-62.

Bouvier, E. L.

1893. Paguriens recueillis par M. Diguët, sur le littoral de la Basse-Californie. Bull. Soc. Philom. Paris, Ser. 8, 5: 18-25.
1895. Sur une collection de crustacés décapodes recueillis en Basse-Californie par M. Diguët. Bull. Mus. Hist. Nat., Paris 1: 6-8.
1898. Sur quelques crustacés anomoures et brachyures recueillis par M. Diguët en Basse-Californie. Bull. Mus. Hist. Nat., Paris 4: 371-384.

Chace, F. A., Jr.

1962. The non-brachyuran decapod crustaceans of Clipperton Island. Proc. U.S. Natl. Mus. 113: 605-635.

Faxon, W.

1893. Reports on the dredging operations off the west coast of Central America to the Galapagos, to the west coast of Mexico, and in the Gulf of California . . . by the U.S. Fish Commission Steamer "Albatross," during 1891 . . . VI. Preliminary descriptions of new species of Crustacea. Bull. Mus. Comp. Zool. 24: 149-220.
1895. Reports on an exploration off the west coasts of Mexico, Central and South America, and off the Galapagos Islands . . . by the U.S. Fish Commission Steamer "Albatross," during 1891 . . . XV. The stalk-eyed Crustacea. Mem. Mus. Comp. Zool. 18: 1-292.

Forest, J.

1952. Contributions à la revision des crustacés Paguridae. I. Le Genre *Trizopagurus*. Mém. Mus. Hist. Nat., Paris, Ser. A., 5 (1): 1-40.

1964. Sur un nouveau genre de Diogenidae (Crustacea Paguridea) de l'Atlantique sud-américain, *Loxopagurus* gen. nov., établi pour *Pagurus loxochelis* Moreira. Zool. Meded. 39: 279-296.

Forest, J., and Michele de Saint Laurent

1968. Campagne de la *Calypso* au large des côtes atlantiques de l'Amérique du Sud (1961-1962). 6. Crustacés décapodes: Pagurides. Ann. Inst. Océan. 45: 47-170.

Glassell, S. A.

1935. New or little known crabs from the Pacific Coast of northern Mexico. Trans. San Diego Soc. Nat. Hist. 8: 91-106.

1936. New porcellanids and pinnotherids from tropical North American waters. Trans. San Diego Soc. Nat. Hist. 8: 277-304.

1937a. The Templeton Crocker Expedition. IV. Porcellanid crabs from the Gulf of California. Zoologica 22: 79-88.

1937b. The Templeton Crocker Expedition. XI. Hermit crabs from the Gulf of California and the west coast of Lower California. Zoologica 22: 241-263.

1938. New and obscure decapod Crustacea from the west American coasts. Trans. San Diego Soc. Nat. Hist. 8: 411-454.

1945. Four new species of North American crabs of the genus *Petrolisthes*. J. Wash. Acad. Sci. 35: 223-229.

Haig, J.

1957. Four new porcellanid crabs from the eastern Pacific. Bull. S. Calif. Acad. Sci. 56: 31-41.

1960. The Porcellanidae (Crustacea Anomura) of the Eastern Pacific. Allan Hancock Pac. Exped. 24: 1-440.

1962. Papers from Dr. Th. Mortensen's Pacific expedition 1914-1916. LXXIX. Porcellanid crabs from eastern and western America. Vidensk. Meddel. Dansk Naturhist. Foren. Kjobenhavn 124: 171-192.

Holmes, S. J.

1900. Synopsis of California stalk-eyed Crustacea. Occ. Pap. Calif. Acad. Sci. 7: 1-262.

Holthuis, L. B.

1954. On a collection of decapod Crustacea from the Republic of El Salvador (Central America). Zool. Verhandl., Leiden 23: 1-43.

Lockington, W. N.

1878. Remarks upon the Porcellanidea of the West Coast of North America. Ann. Mag. Nat. Hist., Ser. 5, 2: 394-406.

Matthews, L. H.

1932. Lobster-krill, anomuran Crustacea that are the food of whales. Discovery Rept. 5: 467-484.

Milne Edwards, H.

1837. Histoire Naturelle des Crustacés, Comprenant l'Anatomie, la Physiologie et la Classification de Ces Animaux. Vol. 2. Paris.

Nininger, H. H.

1918. Crabs taken at Laguna Beach in the summer of 1916. J. Ent. Zool. 10: 36-42.

Nobili, G.

1901. Viaggio del Dr. Enrico Festa nella Repubblica dell'Ecuador e regioni vicine. XXIII. Decapodi e stomatopodi. Boll. Mus. Zool. Anat. Comp. Torino 16 (415): 1-58.

Parker, R. H.

1964. Zoogeography and ecology of some macro-invertebrates, particularly mollusks, in the Gulf of California and the continental slope off Mexico. Vidensk. Meddel. Dansk Naturhist. Foren. Kjobenhavn 126: 1-178.

Radovich, J.

1961. Relationships of some marine organisms of the northeast Pacific to water temperatures particularly during 1957 through 1959. Fish Bull. 112. Calif. Dept. Fish and Game.

Rathbun, M. J.

1910. The stalk-eyed Crustacea of Peru and the adjacent coast. Proc. U.S. Natl. Mus. 38: 531-620.

Ricketts, E. F., and J. Calvin

1939. Between Pacific Tides. Stanford University Press, Palo Alto, Calif.

Saussure, H. de

1853. Description de quelques crustacés nouveaux de la côte occidentale du Mexique. Rev. Mag. Zool., Ser. 2, 5: 354-368.

Scanland, T., and T. Hopkins

THIS PAGE IS LOCKED TO FREE MEMBERS
Purchase full membership to immediately unlock this page

FORGOTTEN BOOKS

FULL MEMBERSHIP

797,885 Books!
All you can read
for only
\$8.99/month

Continue

*Fair usage policy applies



RICAN

**COMP. ZOOLOGICAL
LIBRARY**

EC-3 1972

**HARVARD
UNIVERSITY**

ONS

COMPARATIVE BIOLOGY OF AMERICAN BLACK WIDOW SPIDERS

B. J. KASTON

ABSTRACT. — There are three American species of black widow spiders: *Latrodectus mactans* and *L. variolus* in the eastern U.S., and only *L. hesperus* in the western. Although there is much variation within each species, and to an extent some overlap, they differ in several ways. The egg sac in *L. hesperus* is tan and pyriform, in *L. variolus* gray and pyriform, and in *L. mactans* gray and spherical. *Latrodectus mactans* averages fewer egg sacs per female than *L. hesperus*, but more eggs per sac; *L. variolus* averages the smallest number per sac. The eggs and newly emerged spiderlings are smallest in *L. mactans*, and largest in *L. variolus*; those of *L. variolus* hatch and emerge in the shortest, of *L. hesperus* in the longest time.

Newly emerged spiderlings of each species are characteristically marked, but as they approach maturity they become more alike, especially the females. Mature males are more easily distinguished by their pattern. Red and white marks on the dorsum of mature females tend to be most prominent in *L. variolus* (and the *texanus* variety of *L. hesperus*) less in *L. mactans*, and least or even absent in *L. hesperus*. The hour-glass mark is always divided in *L. variolus*, and generally complete in the others. *Latrodectus variolus* takes longest to mature; *L. mactans* is quickest, and also is shortest lived.

In all three species the spiderlings usually molt only once, occasionally twice, and rarely more times before emergence from the sac. The sexual behavior is similar, and in each a portion of the embolus is left behind in the female genitalia after copulation. The palpal organ of *L. hesperus* is more like that of *L. variolus* generally; but because of the extreme variation, it is not always possible to separate *L. hesperus* and *L. mactans* by embolus coil morphology. The intervals between successive ovipositions and the proportion of eggs that develop from successive egg sacs show no trend toward increasing, or decreasing, and are highly variable in any series.

RESUMEN. — En América existen tres especies de arañas viudas negras: *Latrodectus mactans* y *L. variolus* en la región oriental de los Estados Unidos, y *L. hesperus* en el Oeste. Aún cuando cada especie presenta gran variabilidad en sus caracteres morfológicos y algunos de ellos son comunes, en cierto grado, a varias especies, es posible diferenciarlas fácilmente. En *L. hesperus* el saco ovígero es piriforme y de color marrón, en *L. variolus* es también piriforme pero de color gris, y en *L. mactans* es gris y esférico. Las hembras de *Latrodectus mactans* presentan en general menos sacos ovígeros y más huevos en cada saco que en *L. hesperus*; mientras que en *L. variolus* el número de huevos por saco es menor. Los huevos y las arañitas recién nacidas son de talla menor en *L. mactans*, y mayores en *L. variolus*. Las crías de *L. variolus* tardan menos tiempo en nacer, mientras que en *L. hesperus* la incubación dura más tiempo.

Las arañas recién nacidas correspondientes a estas tres especies presentan caracteres diferentes y bien marcados; pero tales diferencias van reduciéndose progresivamente a medida que alcanzan la madurez, llegando entonces a ser tan similares que resulta difícil diferenciarlas, particularmente tratándose de las hembras. Los machos maduros son sin embargo más fáciles de identificar, considerando el diseño particular que presentan. Las marcas rojas y blancas que aparecen en el dorso de las hembras maduras tienden a ser más prominentes en *L. variolus* (y en la variedad *texanus* de *L. hesperus*) y menos marcadas en *L. mactans*, y en *L. hesperus* esas marcas se desvanecen hasta llegar a desaparecer. La marca en forma de reloj de arena aparece dividida en *L. variolus*, mientras que en las otras especies está completa. *Latrodectus variolus* es la especie que tarda más en alcanzar la madurez, y *L. mactans* madura pronto y es de vida corta.

Las arañitas de estas tres especies pasan, antes de salir del saco, por una sola muda, a veces dos y raramente sufren una tercera muda. El comportamiento sexual es similar en estas tres

especies, y en todas ellas el émbolo queda en las genitales de la hembra después de la cópula. El órgano palpal de *L. hesperus* es similar al de *L. variolus*; pero debido a la extremada variabilidad que presentan los individuos, resulta a veces difícil separar a *L. hesperus* de *L. mactans* basándose en la morfología del rizo del émbolo. Los intervalos entre puestas sucesivas de huevos y la proporción de huevos que se desarrollan en las series de sacos ovígeros no presentan ninguna tendencia particular, ya sea en sentido progresivo o regresivo, variando extremadamente su número en cualquiera de estas especies.

Because of the potency of their venom against man, spiders of the genus *Latrodectus* are of great importance medically. As a result of the interest generated during protracted periods in which cases of envenomation were being regularly reported, and specimens were being collected by many people, several life history studies were made during the 1930's and 1940's. The taxonomic study by Levi (1958, 1959) stimulated a renewed interest, which has continued to the present.

Pickard-Cambridge (1902) published a revision of the genus, in which he considerably reduced the number of valid species. He maintained as distinct however, *L. curacaviensis* (Müller) of the New World, which he separated from *L. mactans* in part on the basis of the hourglass mark being different in form. Nearly all later workers generally assumed that the spider which is most commonly called the "black widow" represented a single, but highly variable, species, *L. mactans*, and the list of its synonyms is long (see Petrunkevitch, 1911; Roewer, 1942; Bonnet, 1957). Thus much of the available information on life history, variation, and so forth, reported for this latter species was "contaminated," being applicable, in part, to the now recognized related species.

Levi (1958, 1959) not only maintained *L. curacaviensis* but considered that it was the species which is widely distributed over the northern and western United States and Canada, with *L. mactans* in the southern States. Levi also discussed the hourglass mark and general pattern of spots, and especially noted instances where both species were completely devoid of such markings. In 1964, with McCrone, he showed that the "brown widow," *L. geometricus* C. L. Koch, and the "red widow," *L. bishopi* Kaston, appear to be limited to southern Florida. Also, of the two species of "black widow," *L. mactans* is more common in southern, and another species more common in the northern States and Canadian Provinces. The species which he had previously identified as the West Indian *L. curacaviensis*, was in reality *L. variolus*. The distribution of *L. mactans* and *L. variolus* overlaps, and although in my previous work (1937a, 1937b, 1938, 1948, 1953, 1954) I had used only the name *L. mactans*, it is known that both species occur in the southern New England area, with *L. variolus* the more common of the two.

McCrone and Levi published some notes on the life history of the Florida populations of *L. mactans* and *L. variolus*, which are sympatric there. They indicated that the same two species also occur in California and other western States. Shortly afterwards I began my observations on the post-embryonic development of our California black widow. At the same time I was also observing the development of a family of *L. mactans* from Florida. In noting the differences, particularly in the appearance of the spiderlings, I assumed that my California specimens, which did not look like the Florida *L. mactans*, must be *L. variolus*. But I found certain discrepancies between my results and those reported for *L. variolus* by McCrone and Levi. In addition, there appeared to be some morphological differences from those specimens of *L. variolus* which Dr. McCrone was kind enough to have sent me from Florida, and from those specimens collected by me years ago in Connecticut. As additional material became available it became apparent that neither *L. mactans* nor *L. variolus* occurs in the west, and that yet another species, *L. hesperus*, is represented (Kaston, 1968). It is my primary aim to compare the biology of this western species with that of the true *L.*

mactans, but some comparisons are made with *L. variolus* as well.

Each of these species is variable so that if one sees enough specimens one encounters the variations noted by Parrott (1946) with the ctenid, *Uliodon piscator*, and by Muller (1952) with the agelenid, *Coelotes atropos*. These variations can be morphological, both exophenotypic and endophenotypic, as well as ethological. And at times they overlap with the characters shown by one or both of the other two species, so that even with a specimen in hand one may not be certain to which species it belongs.

While most of the information presented is based upon studies since 1965, some data were collected in Georgia, in North Carolina, and in Connecticut over many years previous to 1964.

MATERIALS AND METHODS

Specimens were collected from various areas, the majority from California and hence mostly *L. hesperus*. But many live specimens of *L. mactans* were sent from eastern and southern States by cooperative workers. Likewise, a relatively small number of *L. variolus* were obtained. For the most part mature females were received, but a number of males, and some half grown individuals, were likewise obtained.

From the egg sacs produced by these female spiders I set out for *L. hesperus* 29 families (ca. 2600 spiderlings); 18 from California, four from Texas, four from British Columbia, and one each from Arizona, Oregon, and Baja California; for *L. mactans* 37 families (ca. 2800 spiderlings): nine from New York, four each from Virginia and Arkansas, three each from Florida and Illinois, two each from Missouri, New Jersey, North Carolina and Ohio, and one each from Alabama, Louisiana, Mississippi, Oklahoma and Tennessee; and for *L. variolus* 12 families (ca. 900 spiderlings) seven from Missouri, three from Michigan, and one each from Arkansas and Florida. I received the *L. variolus* material late in my study, and unfortunately, because of factors as yet not understood, I had little success in rearing these latter spiderlings to maturity. Live specimens were also received from the following areas: Alberta, Georgia, Kansas, Washington and West Virginia.

Many of the mature specimens were used in studies on the chemical nature of the hemolymph (as in McCrone, 1968); many of the males were sacrificed before maturity for studies on the chromosomes. The results of both these studies are being published elsewhere.

In the laboratory each spider was placed in its own glass container. When egg sacs were made they were removed and each placed in a vial and given a code number. Thus the first sac made by female #1052 was #1052-A, the second was #1052-B, the third was #1052-C, etc. Those used for the study of development and/or for the rearing of spiderlings were kept in a constant temperature room at 25° C.

When the spiderlings emerged, each was placed in its own labelled vial, and given its own number, e.g., #1052-A-1, #1052-A-2, etc. When the spiderling became larger it was transferred to a larger container. The containers were stoppered with polyurethane foam. All specimens were checked and data taken daily. After the spiders matured they were removed from the constant temperature room and kept in one of the laboratories at room temperature.

In the early years of this study the spiderlings were fed entirely on fruit flies, *Drosophila melanogaster*. Although some males matured (in the fourth and fifth instars), the females did not. Apparently nutritional deficiency was involved, possibly an insufficient supply of one of the essential amino acids. Comparable findings were later reported by Miyashita (1968) in his attempts to raise specimens of *Lycosa*. However, when older

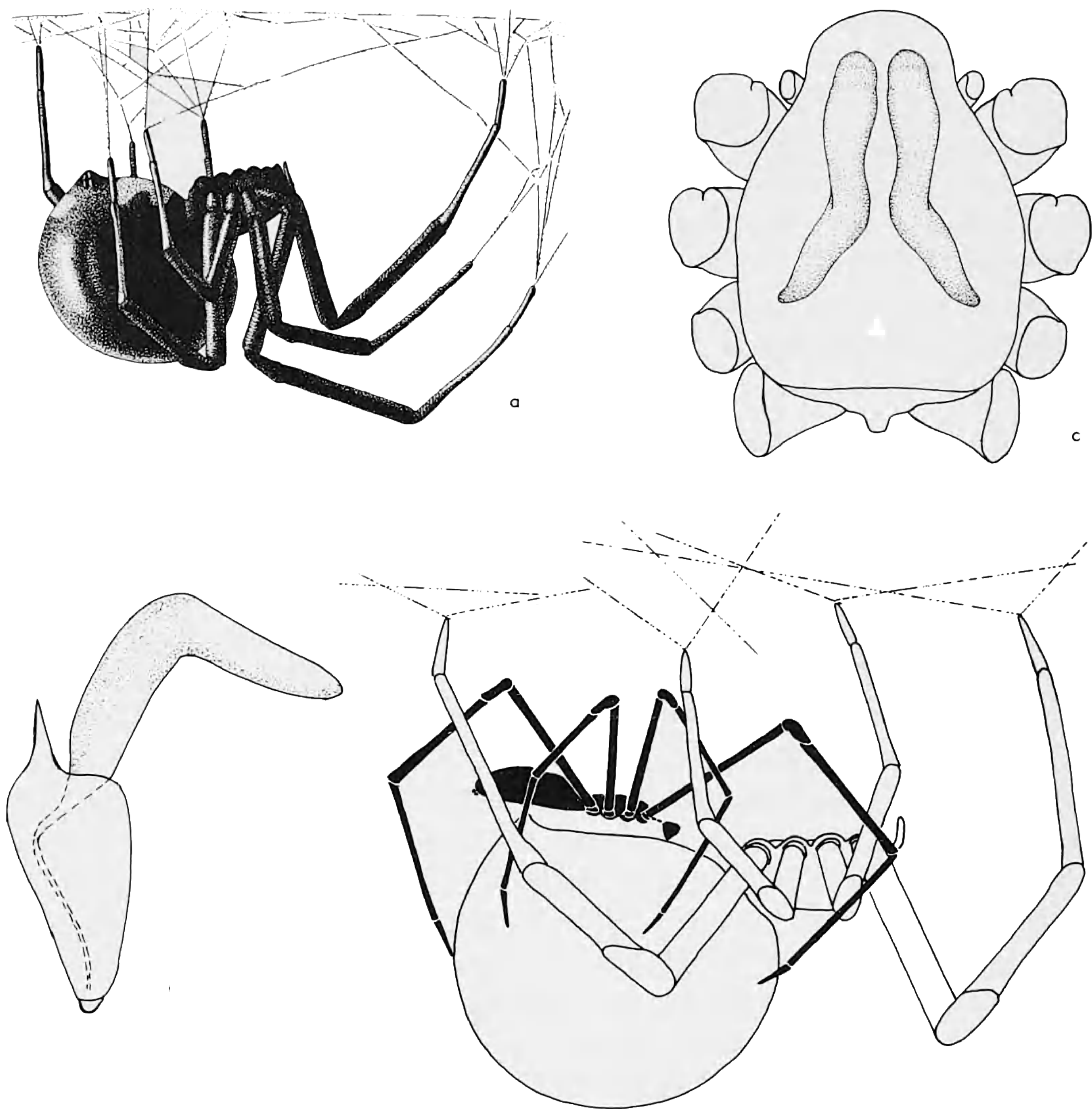

Figure 1. a, Female *Latrodectus* in the normal position hanging in her web; b, *Latrodectus* mating position; the female is represented in outline and the male is blackened; c, the venom glands as seen from above in relation to the entire cephalothorax; d, the left venom gland with its duct, and left chelicera.

spiderlings, as well as the adults, were fed on mealworms, *Tenebrio molitor*, and other insects that could be obtained outdoors, chiefly blue bottle and other muscoid flies, many reached maturity.

DESCRIPTION OF ADULTS

The genus *Latrodectus* Walckenaer, 1805, is cosmopolitan. It comprises medium-sized spiders, which are the largest members of the Family Theridiidae, those spiders bearing a comb of serrated bristles along the ventral surface of tarsus IV. This comb is well developed, and quite conspicuous in *Latrodectus*. The lateral eyes of each side are widely separated, generally a diameter or more apart. The colulus is large and distinct, and the legs are moderately long, with the first usually longer than the fourth, and the third shortest. In females the abdomen is usually relatively large, high and subglobose. The venom glands are large and extend far back into the cephalothorax (Figs. 1c and 1d). Males are much smaller than females, have relatively longer legs, and have the abdomen lower and narrower, so that it appears somewhat ellipsoidal. Males are also commonly more brightly colored. The webs made by these spiders are irregular meshes in which the spider stands in an inverted position (Fig. 1a). Three species occur in the United States, all quite variable in markings and color pattern. The descriptions and illustrations here

THIS PAGE IS LOCKED TO FREE MEMBERS
Purchase full membership to immediately unlock this page

DELVE INTO FANTASY, MAGIC, MYTHOLOGY & FOLKLORE

Forgotten Books'
Full Membership gives
access to 797,885 ancient
and modern, fiction and
non-fiction books.

Continue

*Fair usage policy applies

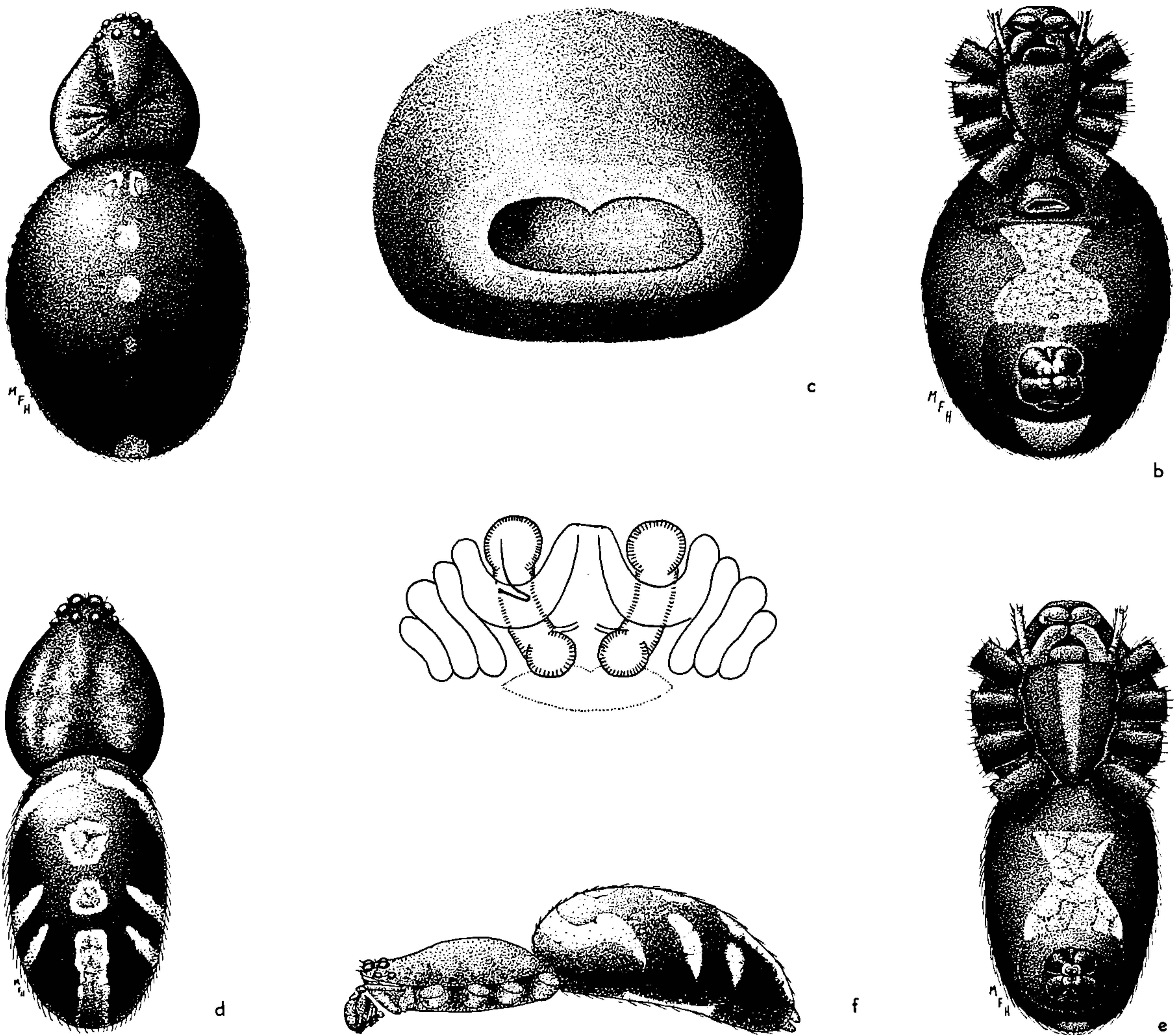

Figure 2. *Latrodectus mactans*. a, dorsal aspect of female from Florida; b, ventral aspect of same female; c, epigynum of same female from below; d, dorsal aspect of male from Florida; e, ventral aspect of same specimen; f, lateral aspect of male from Louisiana; g, dorsal aspect of cleared epigynum of female from New York.

black, or the carapace may show a somewhat lighter band on either side of a median black band. The legs may be all black (Fig. 5c), or have lighter annuli (Fig. 4c) retained from earlier instars. There is a median row of red spots on the dorsum of the abdomen. On the venter the hourglass mark is distinct. Encircling the anterior end of the abdomen is a white band, and on either side farther back are two additional white bands which extend diagonally down and to the rear. Seen from the side this gives the appearance of three white bands (Fig. 2f). In *L. hesperus* there are also three white bands as seen from the side, but the anterior one is always hooked and procurved near its ventral end, while this is uncommon in *L. mactans*. Also, in *L. hesperus* the background color is much lighter. In *L. variolus* the ground color is as dark as in *L. mactans*, and there are four bands visible along the side.

Latrodectus variolus Walckenaer
Figs. 4b, 5a, 6a-f, 7, 14a, b, f

Latrodectus variolus Walckenaer, 1837, Hist. Nat. Insectes Aptères, 1:648.

Latrodectus mactans: Emerton, 1902, Common Spiders of the United States, (in part) fig. 291♂; Kaston, 1948 Connecticut Geol. Nat. Hist. Surv. Bull. 70:92 (for the most part).

Latrodectus curacaviensis: Levi, 1959, Trans American Microscop. Soc., 78:38 (in part).

Latrodectus variolus: McCrone and Levi, 1964, Psyche 71:13

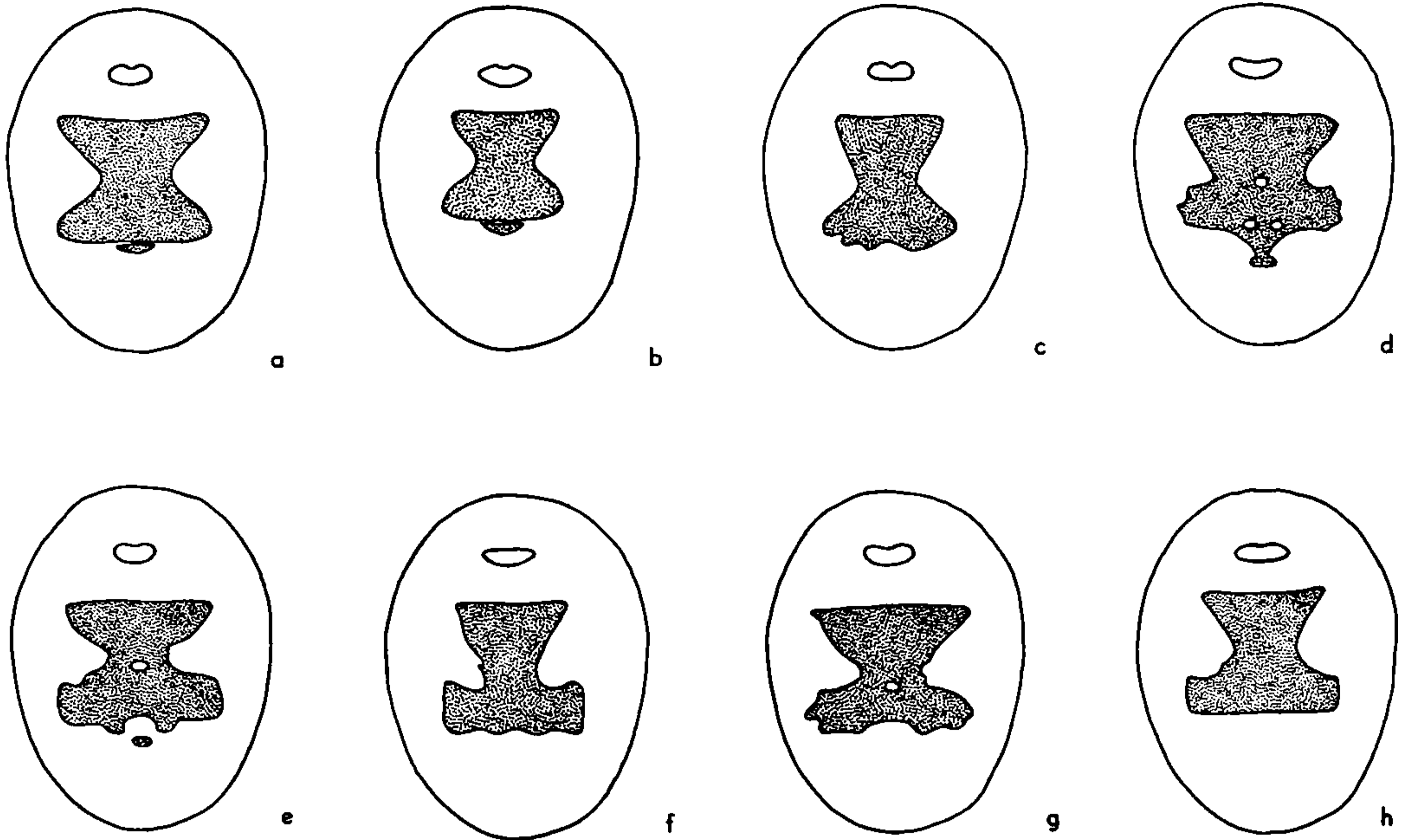

Figure 3. Ventral aspect of abdomens of *L. mactans* females to show variation in the shape of the hourglass mark, and in the epigynal orifice. a, from Arkansas; b, from New York; c, From New York; d, from Tennessee; e, from North Carolina; f, from Virginia; g, from New York; h, from New York.

While most workers seem to consider this species distinct from *L. mactans*, Gerschman and Schiapelli (1965) continue to place *L. curacaviensis* (and presumably also *L. variolus*) as a synonym of *L. mactans*.

This species occurs in the United States in about the same areas as *L. mactans*, but apparently is much less common. However, its range extends into more northern states and adjacent Canadian provinces where *L. mactans* presumably does not occur.

Illustrations of this species have been published recently by Judd (1965) and Wilson (1967). The female has the cephalothorax black, and the legs are similar, usually without faintly brown annuli. There is a row of middorsal red spots on the abdomen. In addition, there are three pairs of diagonal white stripes on each side, and a narrow white stripe encircling the front of the dorsum. In some specimens these stripes are yellowish to pinkish. The hourglass mark is divided, the two halves separated. There is much variation in the shape and the size of the two halves (Fig. 7), occasional specimens showing only one of the halves, and occasional specimens lacking the mark entirely (Kaston, 1954). The male has the cephalothorax and legs black as in the female, but the legs are more likely to show the brown annuli. The dorsum shows a pattern similar to that of the female, but with the white stripes generally broader. From the side four such stripes are visible (Fig. 6f) making this sex relatively easy to distinguish from the males of *L. hesperus* and *L. mactans*, which have only three light stripes. The hourglass mark is divided.

Latrodectus hesperus Chamberlin and Ivie

Figs. 5b, 8, 9, 10, 11, 13e, f, h

Latrodectus mactans hesperus Chamberlin and Ivie, 1935, Bull. Univ. Utah 25(8): Biol. Ser. 3 (1):15 [types from Salt Lake City, Utah].

Latrodectus mactans texanus Chamberlin and Ivie, 1935, Bull. Univ. Utah 25(8): Biol. Ser. 3(1):14 [types from Texas].

Latrodectus mactans: Gerschman and Schiapelli, 1943, in, Sampayo "*Latrodectus mactans* y Latrodectismo" (in part) fig. 7.

Latrodectus curacaviensis: Levi, 1959, Trans. American Microscop. Soc. 78:38 (in part).

Latrodectus variolus: Levi, 1969, Psyche 76:72.

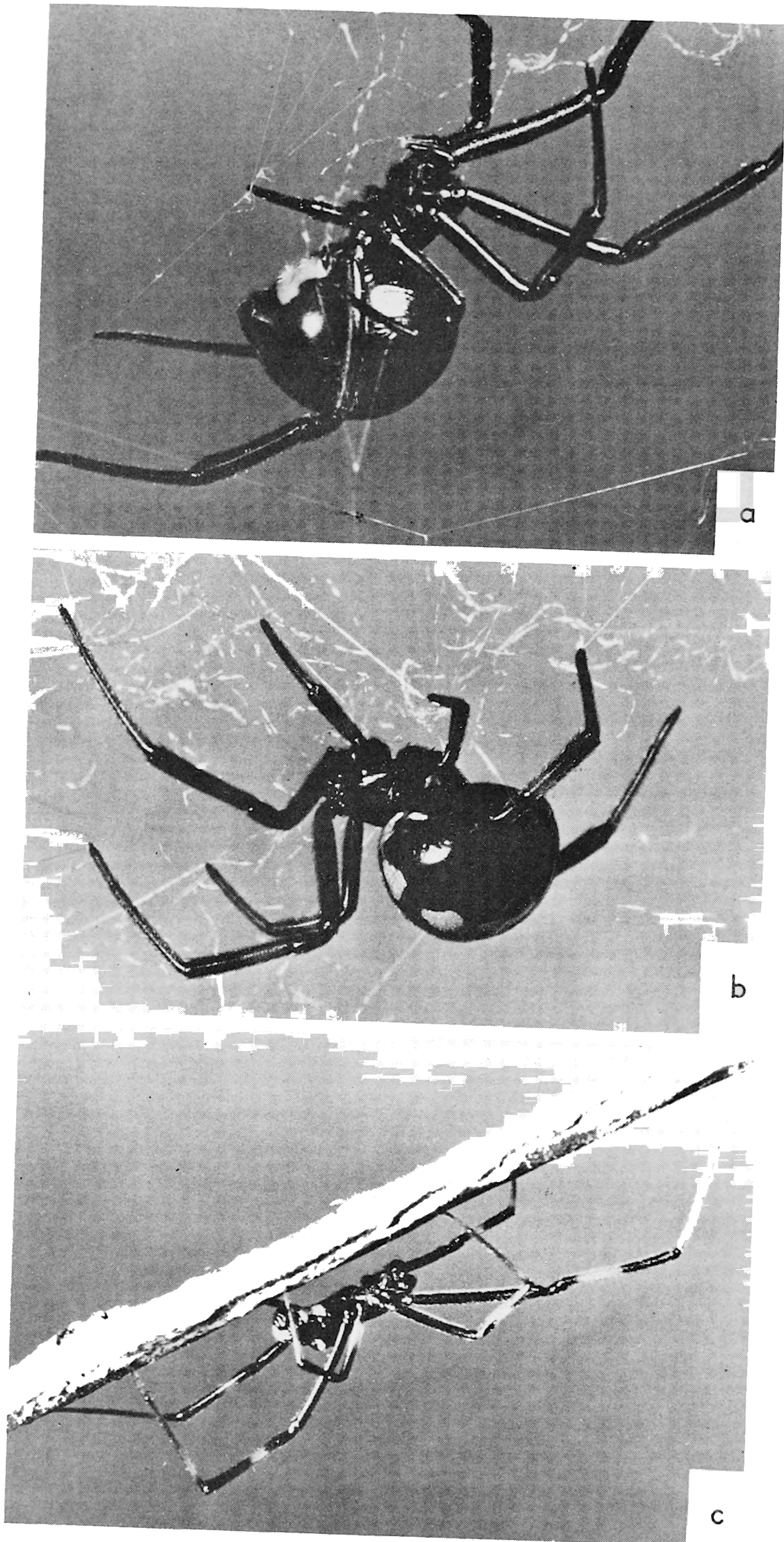

Figure 4. a, *L. mactans* female from Missouri showing ventral surface; b, *L. variolus* female from Connecticut showing dorsal spots; c, *L. mactans* male showing annulate legs.

This is the only species of black widow found west of about the middle of Texas, Oklahoma, and Kansas to the Canadian provinces. Levi has recorded both *L. mactans* and *L. variolus* (sub *curacaviensis*) from the west but, based especially upon the appearance of males and spiderlings, I am unable to ascribe to either of these two species any black widows I have seen from the areas indicated.

The figure 7 supplied by Gerschman and Schiapelli is an exact copy of an illustration from D'Amour et al. (1936) which is of a male from Colorado and quite definitely *L. hesperus*. O'Rourke (1956) indicated that what he had seen from western Canadian provinces belonged to *L. hesperus*. But Levi (1969) synonymized this species with *L. variolus*, presumably on the basis of the fact that the male palpal organ shows two loops of the embolus.

The female has the cephalothorax and legs black. In most specimens the dorsum of the abdomen is likewise entirely black. In only a few is there left a remnant of the middorsal stripe as a small red spot just above the anal tubercle. Also, there may be, on the anterior portion of the abdomen, which overhangs the carapace, a remnant of the light transverse band, as a kind of "chevron" pointing downward. Occasionally this "chevron" is doubled, composed of two closely set thin lines (as in Fig. 10).

Ordinarily the hourglass mark is complete, with a narrow connecting piece between the two triangular halves, and usually the base of the anterior triangle is wider than the base of the posterior triangle. Sometimes there is a spot of black in the center of the connecting piece, or the mark is divided into two parts. There is much variation, some of the varieties being shown in figure 9. Rarely is the middle part broad, and very rarely is the posterior half wider than the anterior.

In the variety *texanus* the dorsum retains more of the white and red, with a central band, and lateral bands much like juveniles in the sixth instar (Fig. 8c). Often the white areas become suffused with black pigment so that older females will show only the red spots surrounded by black. I have this variety not only from Texas, but also from several localities in California. Interestingly enough, both this and the more typical variety sometimes were taken in the same place at the same time.

The male has on the carapace a dark gray to black band along the lateral margins, and a dark band along the middle. The sternum is dark along the lateral borders, but lighter in the middle. The legs show dark annuli. The hourglass mark is not much constricted in the middle and is usually yellow rather than red, some specimens showing a slight suffusing of orange pigment.

The abdominal dorsum shows a characteristic pattern of olive greenish gray alternating with light tan bands (Fig. 8e, f). One of the light areas appears as a middorsal band usually with orange pigment as a thin line down its center. The other light areas appear as three bands on each side, which extend along the sides diagonally down and toward the rear. The most anterior of these is hooked and procurved nears its ventral end (Fig. 8g). The male of *L. mactans* also shows three bands along the side but only rarely is the first one hooked and procurved. In *L. variolus* there are four bands. Moreover, in both *L. mactans* and *L. variolus* the areas between these light bands are much darker than in *L. hesperus*. In the variety *texanus* the gray areas, instead of being suffused with olive-green pigment are suffused with pink.

COLOR VARIATIONS

One common variation concerns the background black characteristic of most adults, especially the females. That the abdomen is in some individuals brownish or sepia in color, rather than black, was reported by Burt (1935) for Kansas specimens that were probably *L.*

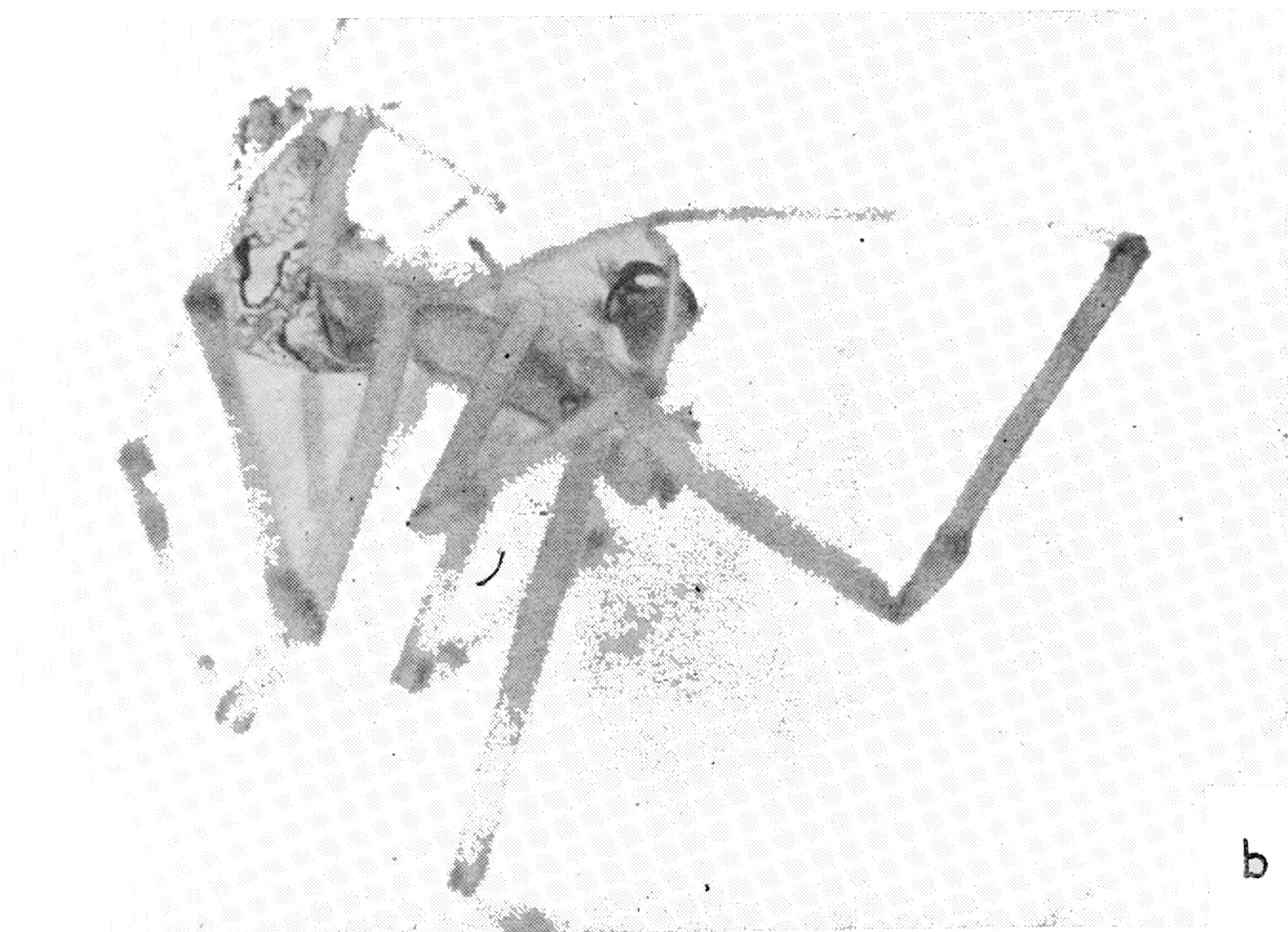
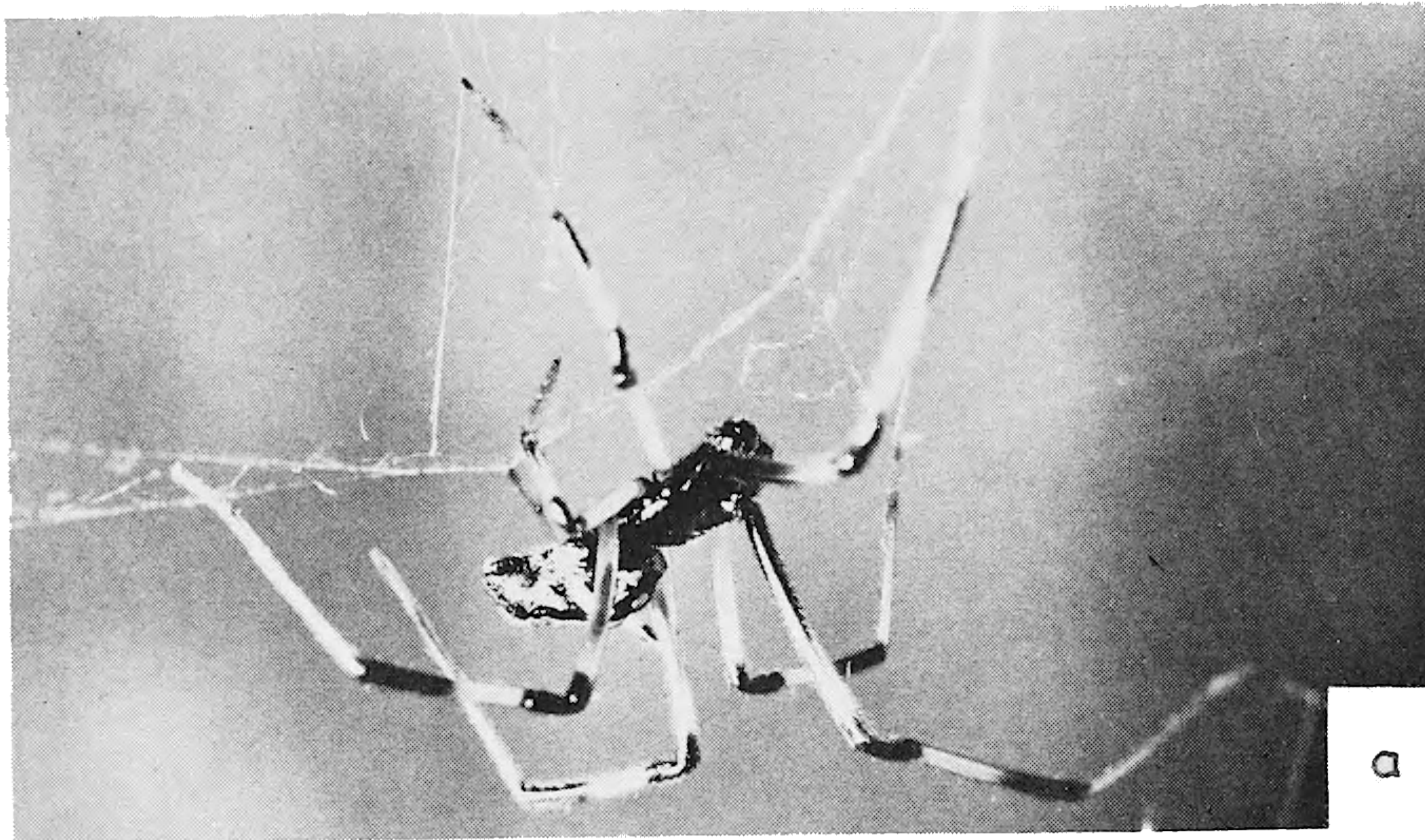

Figure 5. a, *L. variolus* male; b, *L. hesperus* male; c, *L. mactans* male, with legs devoid of annuli.

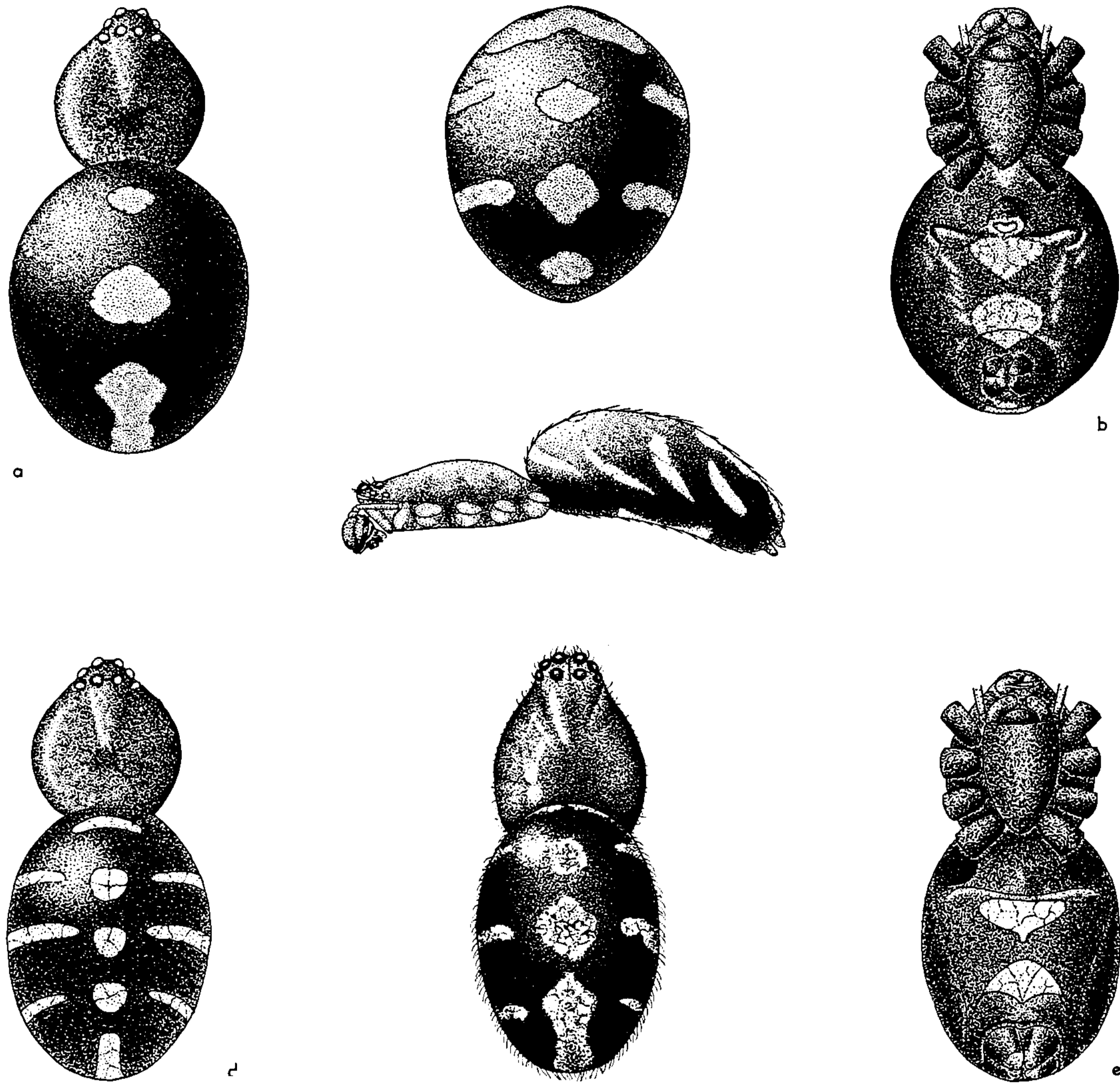

Figure 6. *Latrodectus variolus*. a, female from Florida, dorsal aspect; b, ventral aspect of same female; c, female from Michigan, dorsal aspect of abdomen; d, female from Connecticut, dorsal aspect; e, ventral aspect of same female; f, lateral aspect of male; g, dorsal aspect of penultimate male.

mactans; by Herms et al. (1935) for California specimens that were definitely *L. hesperus*; by Minton (1950) for Indiana specimens that were probably *L. variolus*; and by Wilson (1967) for Michigan specimens of the same species. As I pointed out (1968) for all three species, the same specimen can at times appear black, and at other times sepia or even lighter brown. Some specimens revert to black over a period of several months. My notes indicate that 111 specimens of *L. hesperus* turned from black to brown, and 27 turned black again; twenty-nine specimens of *L. mactans* turned brown, and 9 turned black again; and 8 specimens of *L. variolus* turned brown. I have collected both black individuals and brown ones of *L. hesperus* at Brawley, California, within a few feet of one another, where the ecological situations were seemingly similar. In one backyard lot the ratio of brown specimens to black collected was 9:1.

A variation about which much has been written is the shape of the hourglass mark, and for each species a few examples from mature females are illustrated (Figs. 3, 7 and 9). Sometimes the mark disappears from a specimen which formerly showed it well; but it may also return slowly at a later date.

Pattern variations formed by the red and white marks on the dorsum, have also been noted. It is generally considered that more of a dorsal pattern, and that larger areas of red and white, reflect the retention in the adult of a more juvenile pattern. Reese (1940)

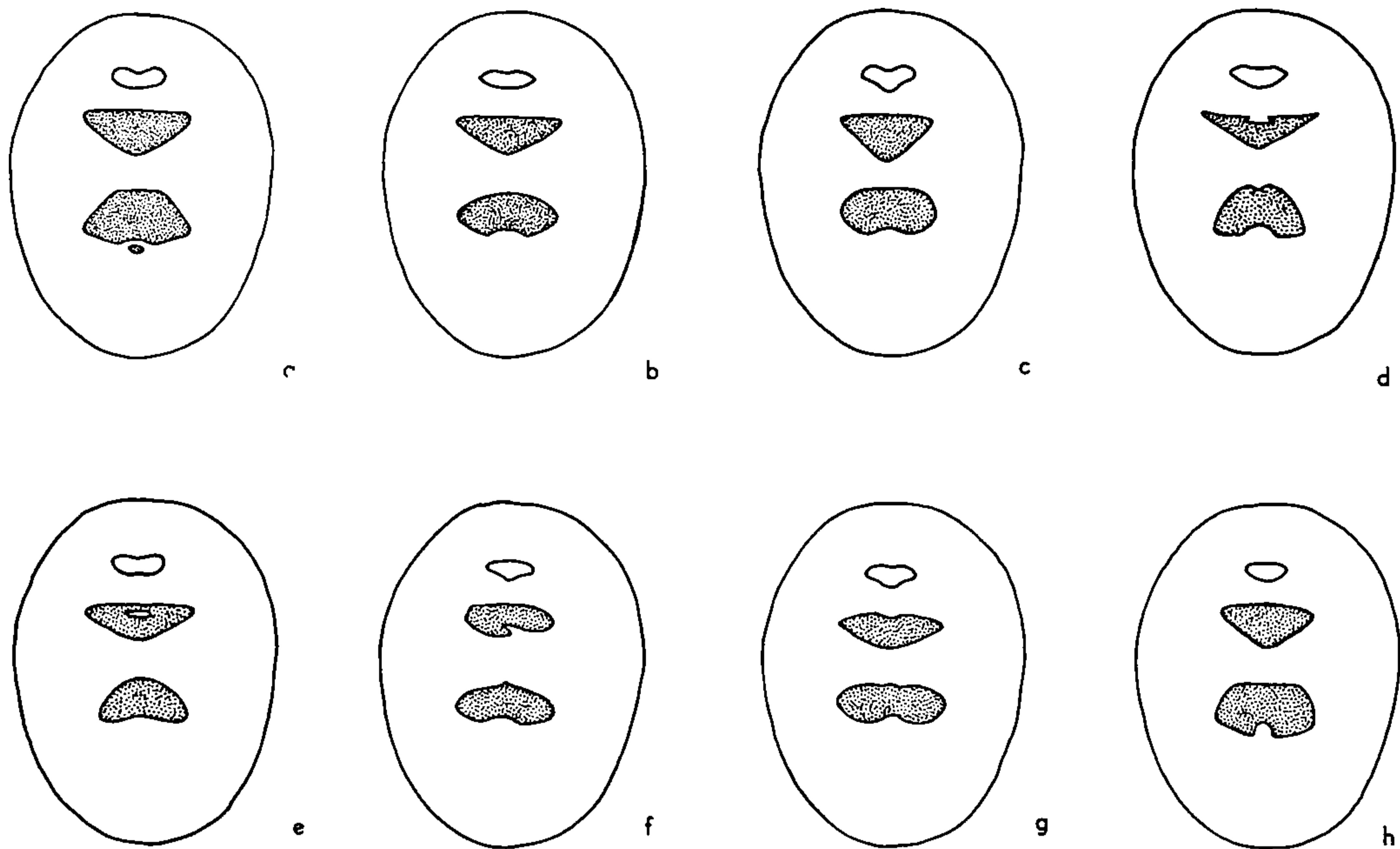

Figure 7. Ventral aspect of abdomens of *L. variolus* females to show variations in the shape of epignyal orifice, and of hourglass mark. a, from Arkansas; b, from Missouri; c, from Michigan; d, from Missouri; e, from Missouri; f, from Michigan; g, from Michigan; h, from Illinois.

illustrated some variations in shape of hourglass mark and the arrangement of dorsal spots. However, he may have included some juveniles, and could have confused *L. variolus* and *L. mactans*, both of which occur in West Virginia. Levi (1959) suggested that Reese's smaller ones were *L. variolus*, and his larger ones *L. mactans*. In my experience, however, *L. variolus* averages larger in size than *L. mactans*. Thorn (1967) gave a brief discussion of the variation in what is undoubtedly *L. hesperus*.

With so much variation occurring in the adult females, the three species at times are difficult to distinguish. But as Keegan (1955) has indicated "juvenile specimens possess distinctive markings even when individual adults are alike." It was on the basis of these differences (between Kansas and Michigan juveniles) that Lawson (1933) first suggested that we were dealing with another species besides *L. mactans*. This other species has since come to be known as *L. variolus*. From what is now known of the appearance of the spiderlings it seems obvious that the descriptions of Herms et al. (1935), D'Amour et al (1936), Moles (1916), Bristowe (1945, 1946) and Gonzales (1954) apply to *L. hesperus*; those of Lawson (1933), Blair (1934), Muma (1944) and Deevey (1949) apply to *L. mactans*; those of Kaston (1937b) to *L. variolus*.

MEASUREMENTS

The vernacular name "black widow" alludes to the commonly held supposition that the female always eats the male after mating. This idea is strengthened by the fact that there is a great difference in size between the two sexes. One often finds in the literature remarks about the female being twice, or even three times as large as the male. Of course, such statements are misleading, for they refer to the length of the body, as in the case of a male 4 mm long and a female 12 mm in length. But the female has thicker legs, and a much higher, globose abdomen, so that her mass may be many times more than three times that of the male. Most males of *L. hesperus* weigh between 8 and 18 mg; most females between 120 and 400 mg. One small male, #1052-C-203 with a body length of 3.5 mm weighed 5.9 mg, and a large gravid female, #1528, whose body length was 12.5 mm, weighed 944.9 mg, or

THIS PAGE IS LOCKED TO FREE MEMBERS
Purchase full membership to immediately unlock this page

FORGOTTEN BOOKS

FULL MEMBERSHIP

797,885 Books!
All you can read
for only
\$8.99/month

Continue

*Fair usage policy applies



among males of *Nephila inaurata* (Walckenaer) reared from the same egg sac by Derouet and Dresco (1956).

Although there is much variation, for females the first leg is proportionately longest in *L. variolus*, shortest in *L. mactans*, and intermediate in *L. hesperus*. In males there is very little difference between *L. hesperus* and *L. variolus*, both of which have the first leg averaging slightly longer than in *L. mactans*.

Besides differences in the length of the legs, there are distinct differences in thickness. Again, it has not been possible to correlate this with species, though in general it seems that the first leg is slimmer in *L. mactans* females than in the two other species. However, in two females of *L. hesperus* collected at Ramona, California, not more than 50 feet apart, one had a tibial index for leg I of 9.3, and the other, of 11.5. Exactly the same sort of finding has been noted for two females of *L. mactans* collected together in New York. This kind of variation in specimens from the same locality was also observed by Smithers (1944) in *L. indistinctus*.

With some spiders there is a direct correlation between width of the carapace and stage of growth (i.e., instar). As indicated above there is a tremendous variation in size in *Latrodectus* even at the time of emergence from the egg sac. Newly emerged spiderlings of *L. mactans* usually range in length from 1.2 to 1.3 mm, with some up to 1.5 mm; those of *L. hesperus* from 1.5 to 1.8 mm; and those of *L. variolus* from 1.7 to 2.0 mm, but sometimes down to 1.4, with the extremes even from the same egg sac. Furthermore, as reported by Shulov (1940) for *L. tredecimguttatus*, many spiderlings molted from the first to the second instar without having been fed, often within a day or two after emergence; no growth can be measured. After measuring many spiderlings, and in several families, I had to conclude, as had Miyashita (1968) for *Lycosa*, that the width of the carapace could not be used for ascertaining the instar.

EPIGYNUM

The epigynum appears externally as a highly arched, heavily sclerotized structure which bulges ventrally, and has a transversely elliptical opening (Fig. 2c). There is much variation in the exact shape and relative length of the opening. In some specimens the anterior lip is developed into a carina, with or without a small median pointed process pointing toward the rear (Figs. 3, 7 and 9). Although not easily seen in the intact specimen, there is, on the dorsal wall of the atrium an opening on each side, leading into connecting ducts, the so-called bursae copultrices. Examination of the cleared epigynum from the dorsal side shows that each bursa copulatrix is rather lightly sclerotized and twines around the heavily sclerotized, darkly pigmented spermatheca of its side. The spermathecae are dumb-bell shaped and lie with their axes making an angle of about 45 degrees to each other and their posterior rounded portions separated by a distance about half the diameter of one of them.

The shape of the atrial opening, and the details of structure vary a little, but the general appearance is the same in all three species. Levi (1966) indicated that there was much variation in his material from Israel, and from the studies of Lucas and Bücherl (1965) one would expect some variation even in sisters.

In *L. mactans* the connecting ducts have four outside coils (Fig. 2g), while in *L. variolus* (Fig. 14f) and *L. hesperus* (Fig. 11f) there are only three. This makes the epigynum of *L. mactans* appear wider than that of the other two species. Commonly the spermathecae and/or the connecting ducts will contain one or more embolic fragments left behind by the male after mating (Figs. 2g, 11g, 11h).

According to Bhatnagar and Rempel (1962), who studied the structure of the

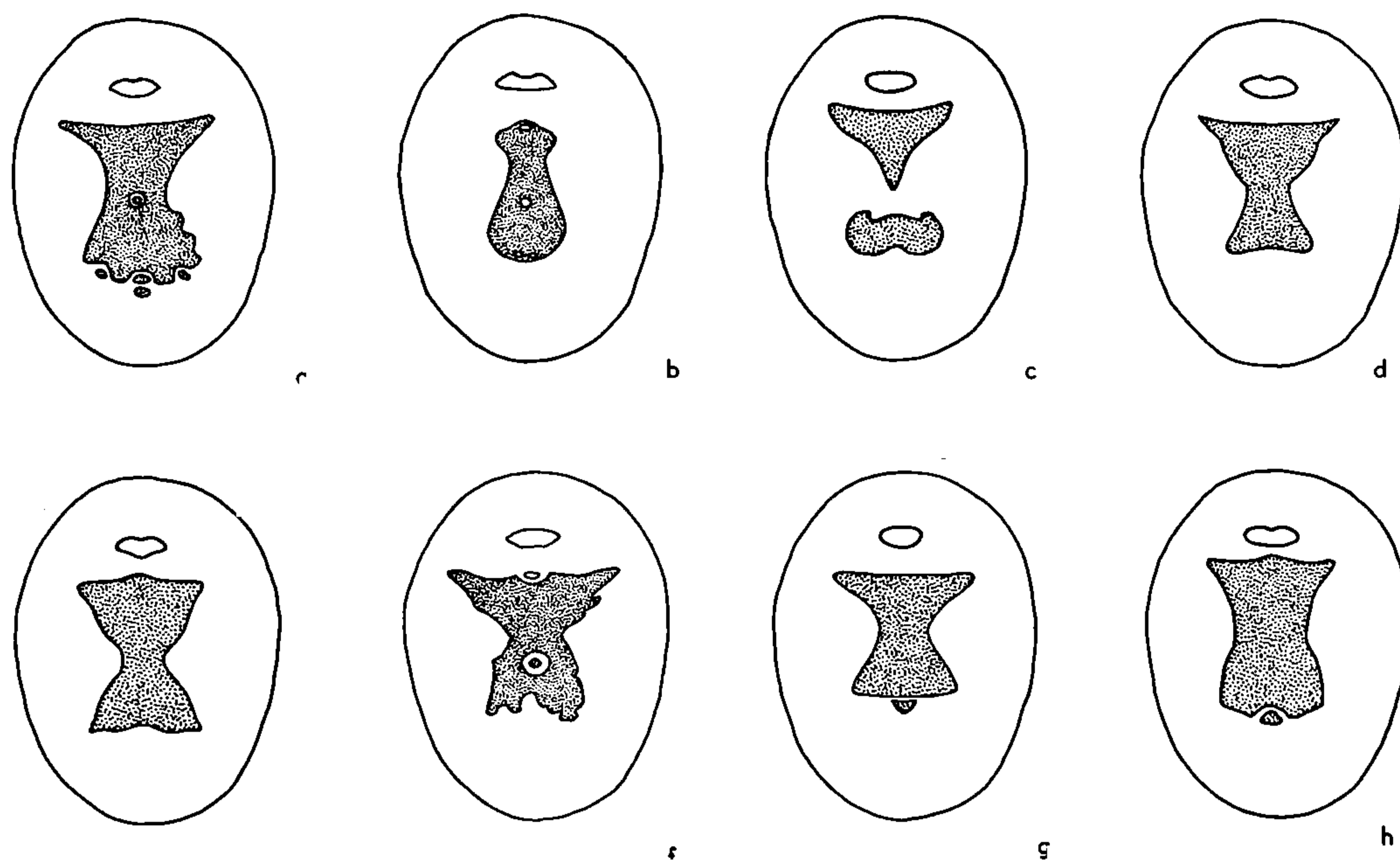

Figure 9. Ventral aspect of abdomens of *L. hesperus* females to show variations in the shape of the epigynal orifice, and of the hourglass mark. a, from Texas; b, from British Columbia; c, from Washington; d, from California; e, from California; f, from California; g, from California; h, from British Columbia.

epigynum of *L. hesperus*, the openings of the ducts into the spermathecae lie "on the middle portion of the spermathecae on the latter's outer lateral margin."

In specimens one molt short of maturity the area where the epigynum will later show appears much arched. Thus it is possible to recognize one in the penultimate instar. In the antepenultimate instar the area is usually somewhat lighter than those surrounding areas, but definite recognition of females in this stage is not easy.

PALPAL ORGAN

Although Levi (1959) greatly reduced the number of species of *Latrodectus*, partly on the basis of similarity of palpal structure, he later (1966) admitted that the morphology of the palpal organ may be the same in two or more species. He accepted for North America only three species: *L. mactans*, in which the embolus shows three coils, *L. geometricus*, in which it shows four, and *L. curacaviensis*, in which it shows two. In 1964, with McCrone, he acknowledged that the true *L. curacaviensis* did not occur in North America, and that there were two additional species in which the embolus had two coils. These are *L. bishopi*, of south Florida, and *L. variolus*, which is widely distributed over the United States. Abalos and Baez (1967) and Pinter (1968) appear to have demonstrated that there are at least three additional species in the "*mactans* group" and one additional in the "*curacaviensis* group." I consider *L. hesperus* a good species in the latter group, though some specimens show traits that would lead to its placement in the former group. This could account for Levi's distribution lists showing both *L. mactans* and *L. variolus* in the western States, where in my opinion neither one occurs.

In all three species there is a long spirally coiled embolus (Figs. 11a, b, c, 12a, b, 14a, b). The origin of the embolus from the radix is broad, and shows a thick curved tooth. There follows the heavily pigmented trunk of the embolus on the outside of the coil, paralleled by the membranous pars pendula on the inside of the coil. Near the distal end of the embolus is a blunt tooth marking the proximal articulation of the apical sclerite. After copulation the embolus breaks at this point, and the apical sclerite can be found lying

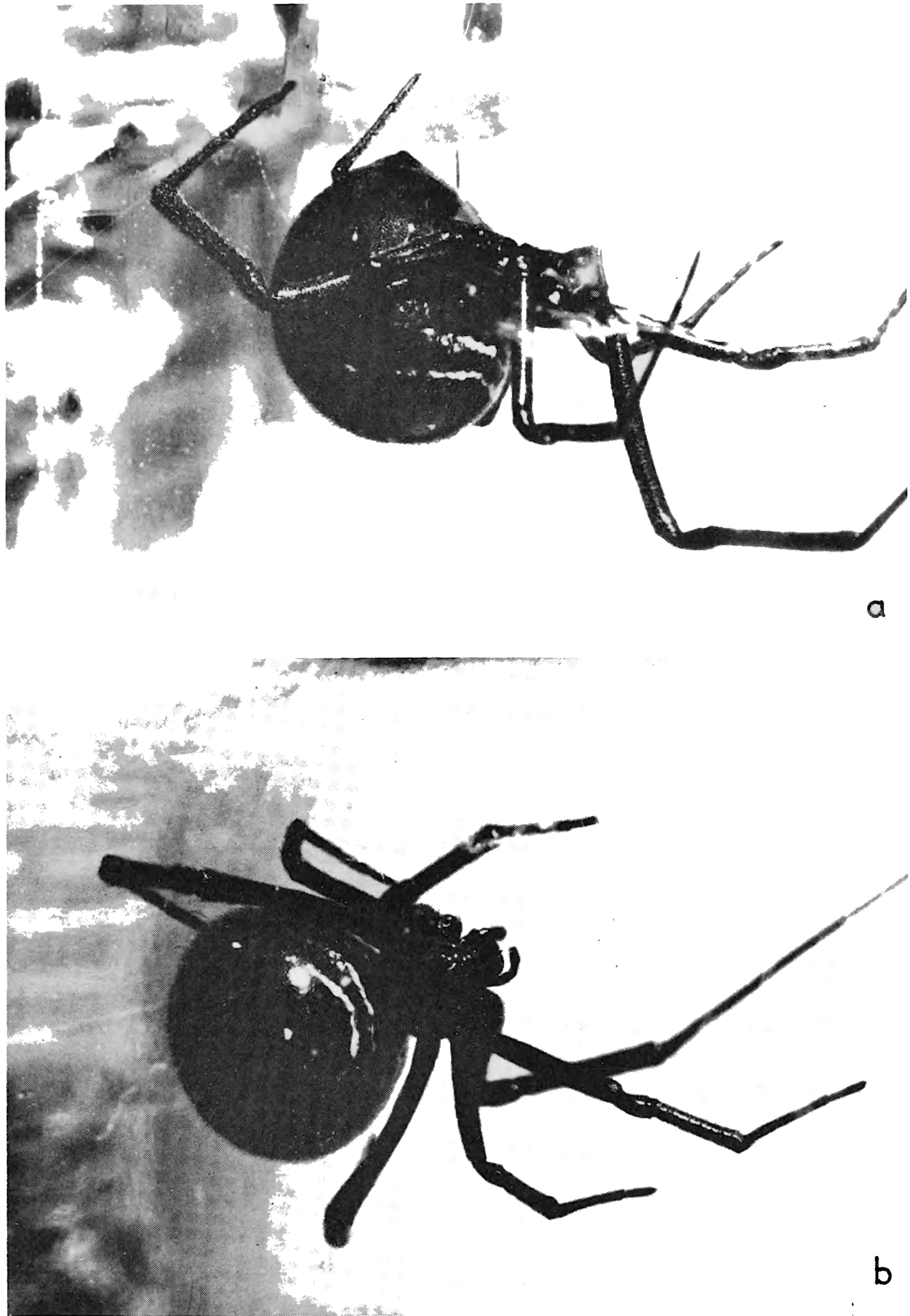

Figure 10. *Latrodectus hesperus*. a, female from California showing anterior chevron marks on abdomen, from the side; b, same female, showing chevron marks from above and front.

within the parts of the female genitalia (Figs. 2g, 11g, h). This phenomenon, which in recent years has been shown to occur in other spiders too, was according to Gerhardt (1928) first described for *Latrodectus* in 1902 by Dahl. It was later noted by Smithers (1944), Abalos and Baez (1963, 1967), Gerschman and Schiapelli (1965), Wiehle (1967) and Bhatnager and Rempel (1962). The latter's work included detailed studies on the structure of the palpal organ and female genitalia. Their specimens had come from Kamloops, British Columbia, and from my own observations on abundant material from that very same locality it is quite certain that they were working not with *L. curacaviensis*

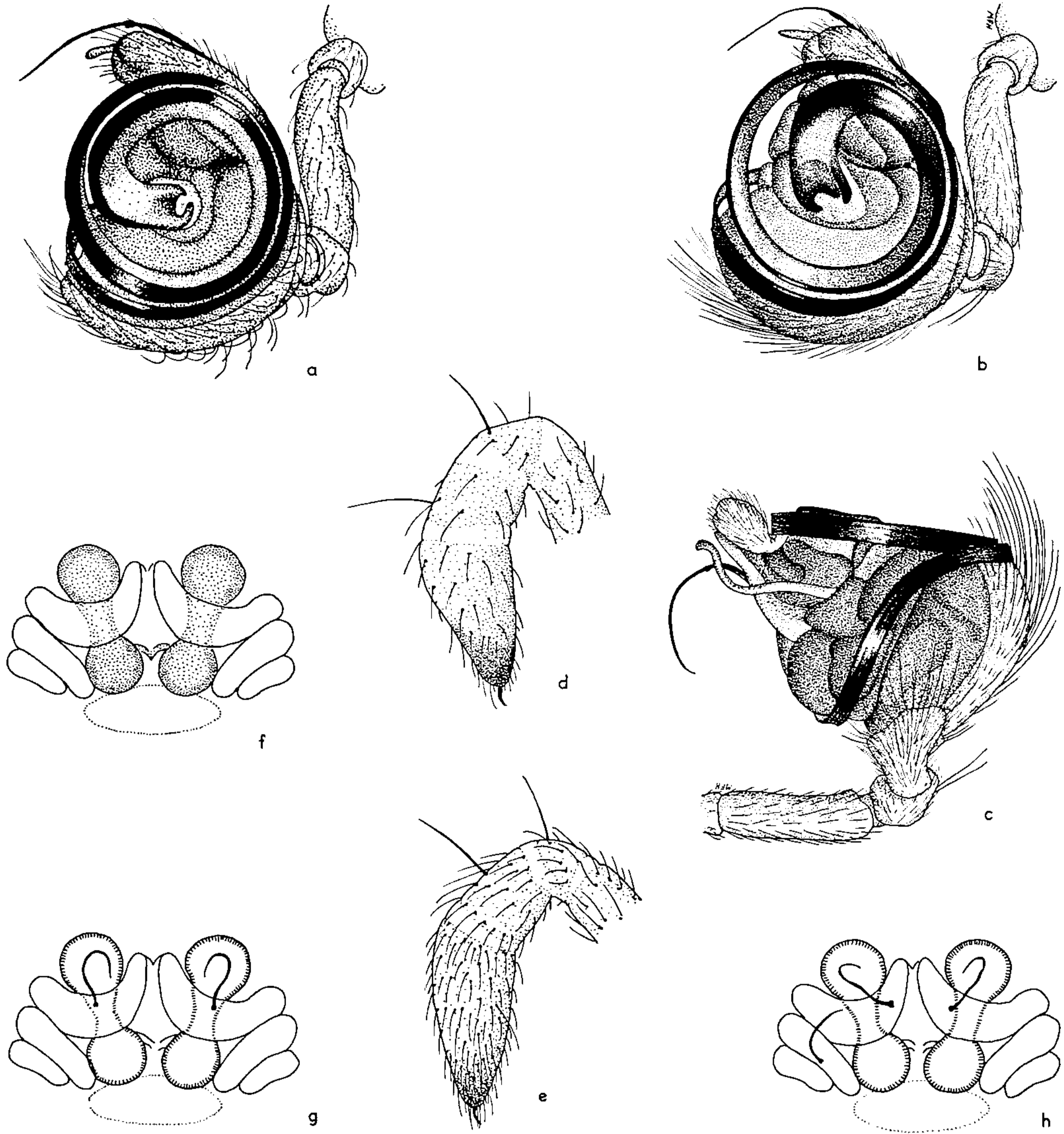

Figure 11. *Latrodectus hesperus*. a, apical aspect of the palpal organ of the type male from Utah; b, the same, for a male from Arizona; c, same palp, ectal aspect; d, distal end of pedipalp of a male in the preantepenultimate instar; e, the same from a male in the antepenultimate; f, dorsal aspect of a cleared epigynum of a virgin female from Oregon; g, the same, from a California female that had mated, showing an embolic sclerite left behind in each of the spermathecae; h, the same, from another California female showing three embolic sclerites, indicating that it had mated with at least two males.

as stated, nor with *L. variolus* as implied in McCrone and Levi (1964), but with *L. hesperus*.

In the resting position, the distal end of the embolus usually lies against the conductor, but extends somewhat beyond it. Adjacent to the conductor is the heavier terminal apophysis, and just proximad of this is the sickle-shaped median apophysis. The distal border of the latter is provided with a socket into which fits a heavily sclerotized tooth borne near the distal end of the cymbium (Fig. 13a). Smithers described this tooth as two-lobed in *L. indistinctus* and *L. geometricus*, and indicated that these two species differed with respect to the size and shape of the two lobes. Levi (1959) referred to this cymbial tooth as a "paracymbial hook" and illustrated it for *L. mactans*, as well as for other species. It would seem that his usage of the term is ill-chosen, for the term paracymbium is already in use for a structure arising from the basal portion of the cymbium. In my studies on our three species I have found this tooth to be single-lobed, as illustrated by Bhatnagar and Rempel (1962). That Levi illustrates the tooth as two-lobed indicates a mis-

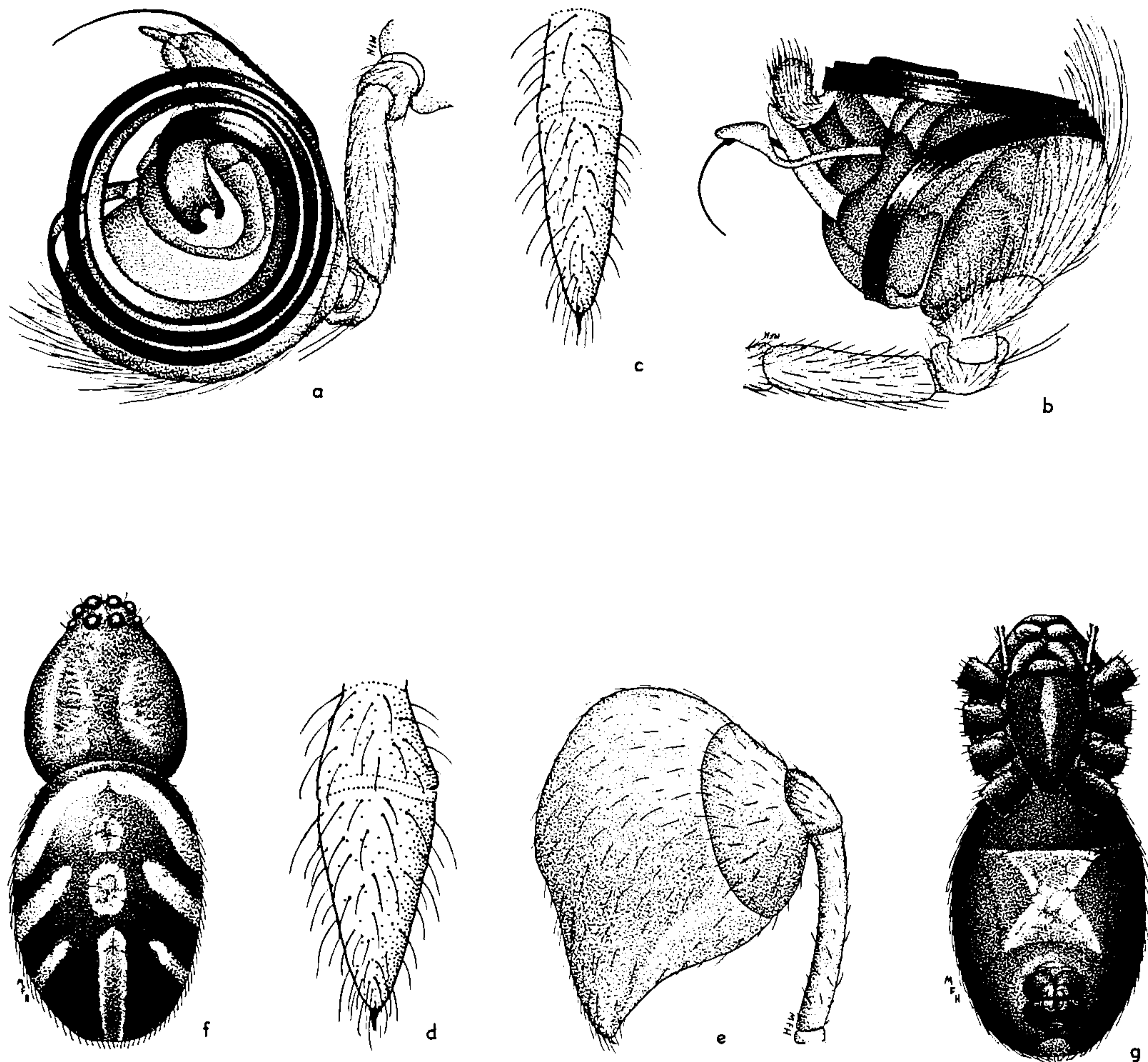

Figure 12. *Latrodectus mactans*. a, apical aspect of palpal organ of a male from Florida; b, ectal aspect of same palp; c, distal end of pedipalp of a mature female; d, distal end of pedipalp of an antepenultimate male; e, distal end of a pedipalp of a penultimate male; f, dorsal aspect of a penultimate male from Florida; g, ventral aspect of same male.

interpretation. The tooth is strongly sclerotized and pigmented, and from the point of its attachment at the edge of the cymbium the latter shows the same degree of sclerotization and pigmentation. This may give the impression of a two-lobed process (Fig. 13a). But if one views the structure from the apicomesal (Fig. 13b), the mesal (Fig. 13c) or the ectal aspect (Fig. 13d) its single nature can be seen.

Levi found, that to some extent at least, the character of the embolus could be used to separate species. In *L. variolus* it is wider than, and about three-fourths as long as, in *L. mactans*, and it makes two coils in *L. variolus*, but three in *L. mactans*. Moreover, I noted that the coils are tighter and less open in *L. variolus* than in *L. mactans*.

In the type male of *L. hesperus* the embolus (Fig. 11a) shows two coils (as in the "curacaviensis group") though it appears longer than in *L. variolus*, as the coils are more open. However, the coils are tighter and less open than in *L. mactans*. But there is much variation among the many specimens of *L. hesperus* that have been studied. In fact I have seen many specimens that could not be identified on the basis of coil morphology. For example, figure 13h represents the palpal organ of a *L. hesperus* specimen from Los Angeles, California, and figure 13k the same of a *L. mactans* specimen from Rutledge, Georgia. Note the similarity between figure 13g of a Gainesville, Florida specimen of *L. mactans*, and figure 13e of an El Centro, California specimen of *L. hesperus*. Adding to the confusion is the fact that the basal portion of the embolus sometimes extends from its origin towards the distal end of the palp, sometimes towards the basal, or the mesal, or the

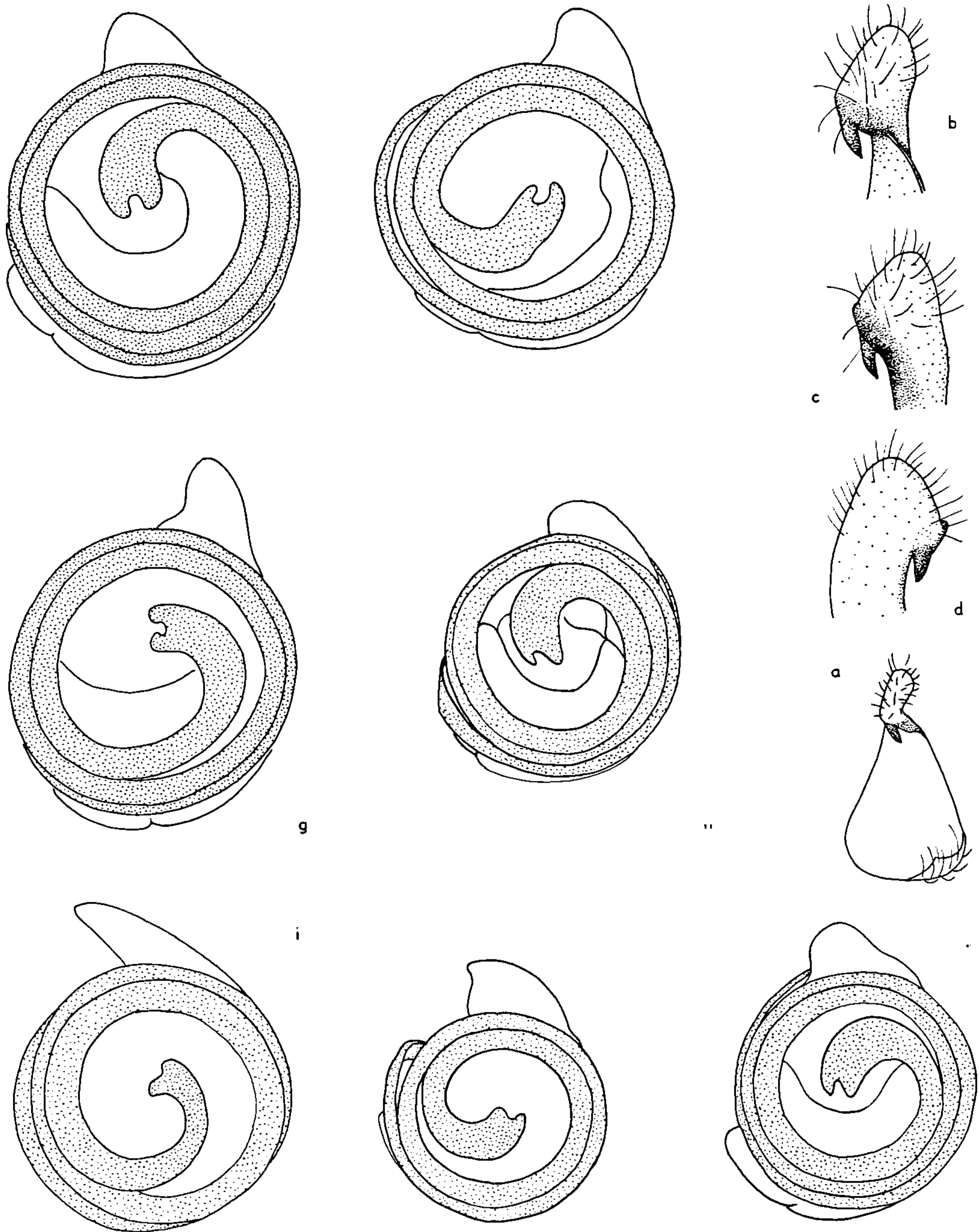

Figure 13. a, cymbium of pedipalp of a New York specimen of *L. mactans*; b, cymbial book as seen from the apicomeral aspect; c, the same, mesal aspect; d, the same, ectal aspect; e, embolus of *L. hesperus* male #1002-A-51 from El Centro, California; f, the same, of a litter-mate, #1002-A-48; g, the same, of *L. mactans* male #1005-B-39 from Florida; h, the same, of *L. hesperus* male from Los Angeles, California; i, the same, of *L. mactans* male #1005-C-29 from Florida; j, the same, of *L. mactans* male #1005-B-49 from Florida; k, the same, of *L. mactans* from Georgia.

ectal sides; and Levi's illustrations likewise show these variations. The problem becomes one of deciding where to make the coil count, since, of course, it is not a matter of concentric circles, but of a spiral. Even two brothers may look quite different, and have been mistakenly considered as belonging to different species, e.g., *L. hesperus* #1002-A-48 (Fig. 13f) and #1002-A-51 (Fig. 13e). Obviously, therefore, one must expect some specimens of *L. hesperus* to show an apparent three coiled condition. The same is sometimes noted with brothers of *L. mactans*, e.g., #1005-B-39 (Fig. 13g) and #1005-B-49 (Fig. 13j). Note the similarity between the latter and figure 13f of the *L. hesperus* specimen. Also note the similarity between the former and the *L. hesperus* figure 13e. Many other

variations occur, and the figure 13i shows another *L. mactans*, brother of the previous two.

Levi's (1959) specimen from Colorado (undoubtedly *L. hesperus*) illustrated in his figure 58 and labelled *L. mactans* by him appears almost identical with my *L. hesperus* from Los Angeles, figure 13h. Similarly, in his figures 40 through 47, representing *L. geometricus*, some appear to show the four coils characteristic of that species and others show only three. Likewise, his figure 61 of a Peruvian *L. mactans* is almost identical with his figure 47 of a *L. geometricus* from South Africa; both show three coils over part of the circumference, and four over part.

It would seem that the number of coils of the embolus cannot be used alone as a character for separating the species. Yet in effect this is presumably what Levi has done, and because he has found in Utah (and other western States and Provinces) both three-coiled and two-coiled specimens he naturally supposed that he had both "*L. mactans* and *L. curacaviensis* [actually *L. variolus*] both of which are found in Utah," and that Chamberlin and Ivie failed to distinguish them. As has been previously indicated, I believe that our western black widow is *L. hesperus*, and further that the variety *texanus* is a variety of *L. hesperus*, and not of *L. mactans* in the strict sense.

In nearly all araneomorph spiders the male can be recognized in the penultimate instar, because the palpal tarsus appears bulbous then (fig. 12e). Because the palpal organ in *Latrodectus* is relatively large, its development begins even before the penultimate instar. Hence the palpal tarsus is slightly swollen in the antepenultimate instar (Fig. 12d) so that it is possible also at this stage to recognize a male. The swelling may be noticed even in the preantepenultimate instar (Fig. 12c) as suggested by Bhatnagar and Rempel (1962), but I have not found this a constant character. On the other hand I have noted a number of instances in which there are three (not just two) instars preceding the penultimate one, in which a slight enlargement of the palpal tarsus gives an indication that the specimen is a male. I have also noticed that the degree of swelling is not the same for all individuals in the preantepenultimate or antepenultimate instars. There are indications that some expansion occurs during an instar itself.

INTERNAL MALE GENITALIA

Chromosomes were studied in the cell divisions taking place in the testes. The detailed description of meiosis and of the individual chromosomes is being reserved for a separate publication elsewhere by Barbara Kaston. Suffice it to say that in all three species she has found that the sex chromosome situation is of the $X_1 X_2 O$ type, so that in the female the diploid condition shows two chromosomes more than in the male.

The dissection of the testes was carried out by submerging the freshly severed abdomen in frog Ringer's solution and pinning it venter down in a wax-bottomed dish. A cut was made along the middorsal line and the dorsal exoskeleton removed. Usually the heart remained adherent to the exoskeleton, and the testes became visible as two tubes only slightly kinked, and arched (Fig. 19c) to more or less conform to the curve of the dorsum. The testes are loosely attached to each other by short bands of connective tissue and at the posterior end are attached in the region of the spinnerets by a longer ligament. At the anterior end of each testis is a ductus deferens, which extends forward, then downward and backward, joining its mate just before the gonopore at the middle of the epigastric furrow.

It should be noted that although Millot (1949) described the testes of spiders as lying in the ventral half of the abdomen, and below the chylenteron, and his figure 454 shows this for *Scytodes thoracica*, in *Latrodectus* the testes for most of their length lie fairly close to the heart in amongst the chylenteric ceca. While not as short and straight as given by Bertkau (1875) for *Tegenaria domestica*, they are not as long nor as convoluted as in the

THIS PAGE IS LOCKED TO FREE MEMBERS
Purchase full membership to immediately unlock this page

DELVE INTO FANTASY, MAGIC, MYTHOLOGY & FOLKLORE

Forgotten Books'
Full Membership gives
access to 797,885 ancient
and modern, fiction and
non-fiction books.

Continue

*Fair usage policy applies

COURTSHIP AND MATING

In nature, mating most often occurs in the late spring and early summer, but in mild climates, such as along the Pacific coast and in our southern states mating pairs may also be seen in late summer and early fall as well.

The courtship and mating behavior for *L. hesperus* was reported by Herms et al. (1935) and D'Amour et al. (1936), and for *L. bishopi* by McCrone and Levi (1964). It is essentially similar to that described by Gerhardt (1928) for *L. tredecimguttatus*, by Shulov (1940) for that species and *L. pallidus*, and for *L. indistinctus* by Smithers (1944).

Presumably, before the male begins his search for the female, and courtship is to begin, the male will charge his palpal organs with semen. I have not observed this process of sperm induction. Herms et al. (1935) reported that they had seen it, but gave no details.

The length of the courtship preliminaries varies, but generally is shorter with young females than with older ones. For these observations the female was allowed to establish herself for at least a week in a large glass cage. The male was introduced at the upper corner farthest from the female.

Almost immediately upon being put into the female's cage the male shows signs that he is aware of the female's proximity. The abdomen is vibrated rapidly, and with jerky movements of the legs the male wanders about, every once in a while twanging the threads as he progresses. Eventually he heads in the direction of the female. Within 10 or 15 minutes he begins a new maneuver, which consists of cutting portions of the female's web. He continues this cutting as he approaches her, so that the silk is gathered up in concentrated bands and sheets, instead of appearing spread out as before. Sometimes the female charges at him, whereupon he hastily retreats. After a short rest with his abdomen not twitching, he once more approaches her. This charging and retreating may be repeated several times, but if it continues and the female becomes violent in her rushing, the male may remain at a distance and eventually discontinue his courtship.

If the female is not too aggressive he may find himself within touching distance of her within 30 minutes (Fig. 15). With his front legs he strokes and taps her legs, and then her body. This contact heightens his excitement so that his abdomen twitches more rapidly. If the female does not kick him away she too may begin to engage in leg stroking activity. The male then walks over and around the female jerkily, at the same time surrounding her with silken threads. This "bridal veil," which I have seen used by crab spiders and others, was observed for *Latrodectus* by Gerhardt, and by Smithers, as well as by Herms et al., but was apparently not observed by McCrone and Levi. As Smithers indicated, the threads are too fine to hinder her when she later decides to break loose, but serve to remind her that "her partner is in attendance."

Sooner or later in his wanderings over her body, with his pedipalps constantly tapping her, he locates the epigynal area. Some time may be spent "boxing" this area, apparently in an attempt to hook into the opening. Finally, after having been in the female's web about 100 to 140 minutes, he assumes the copulatory position, position III of Gerhardt, in which both sexes face the same way, venter to venter (Fig. 1b).

Sometimes the right palp is used first, and sometimes the left. When the palp is hooked into position, the embolus is inserted and the hematodocha distended, then deflated, indicating that semen is being transferred. Insertions may last from one to 32 minutes, but most often from 4 to 8. Sometimes the female struggles out of her bonds after only a few minutes, too short a time for the male to have inserted more than one palp. She may now turn upon him aggressively, so that he is forced to retreat.

Often the male will try again by going through the same ritual of cutting web lines,

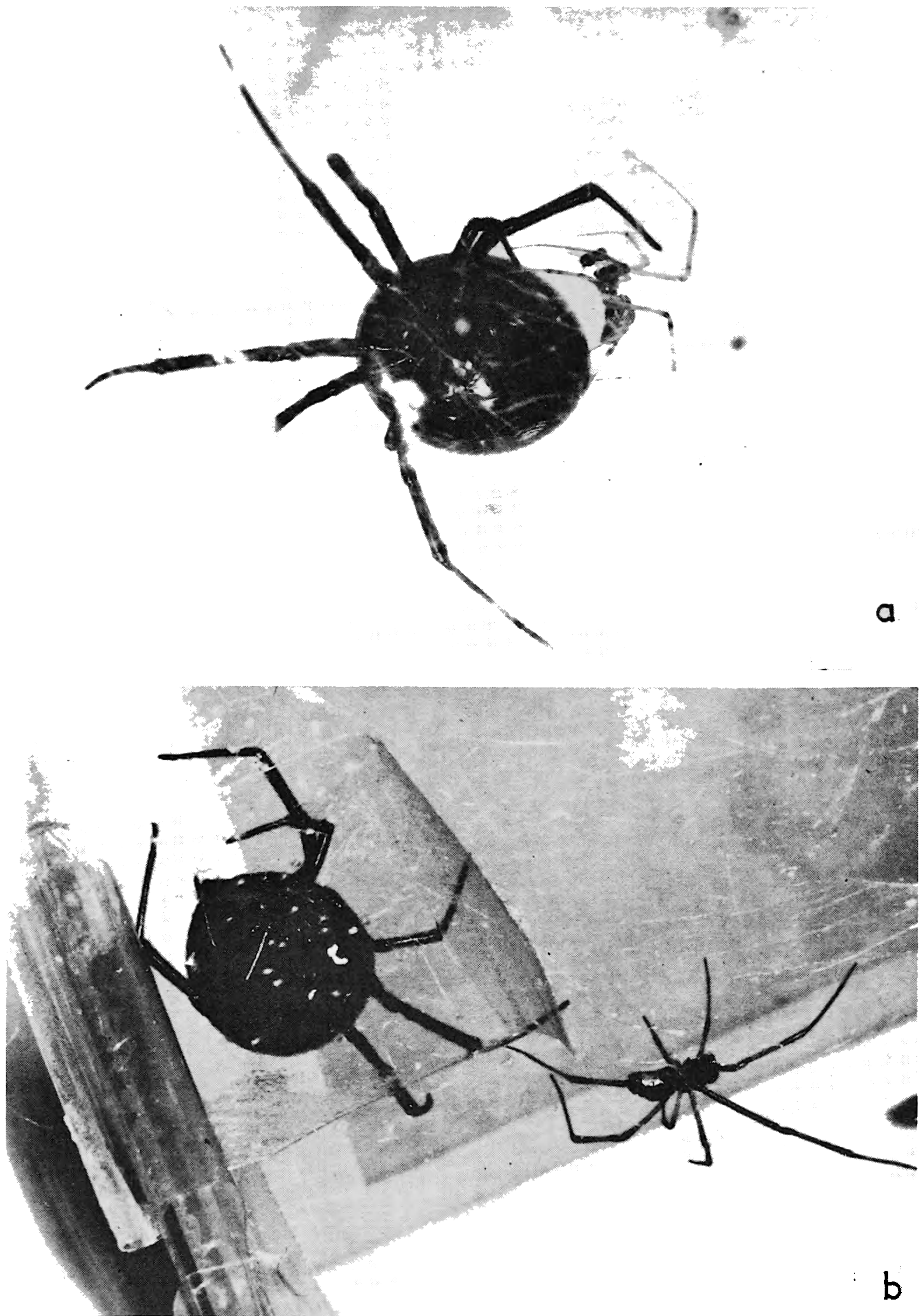

Figure 15. Courtship pairs. a, *L. hesperus*; b, *L. mactans*.

twanging threads, and vibrating the abdomen.

If the female remains still after the first palp is withdrawn, the male will insert the other palp. This occurred in about one third of the matings observed. It is well known that when the female frees herself from the "bridal veil" the male may be in danger. If she is hungry she may kill and eat him. With well fed females this is not likely to happen, and I have on several occasions left the male in the cage with her. In the course of time, two weeks or more, the male dies untouched by the female.

Upon withdrawal of the embolus the distal sclerite is left behind in the genitalia of the female. Depending upon whether one or both palps have been used, there will be one or two

sclerites (Figs. 2g, 11g). But sometimes one epigynum will show three sclerites (Fig. 11h) indicating that the female had mated with at least two males.

Of 51 attempts with *L. hesperus*, where courtship was carried out, there were 12 successful cases of insemination. Of 13 attempts with *L. mactans*, 5 were successful, and of 8 attempts with *L. variolus* 5 ended successfully. The behavior appeared the same in all three species. When insemination did not occur, it was usually because the female repulsed her partner before the act could be completed.

I tried to induce interspecific crosses between *L. variolus* and *L. mactans* (4 attempts) and between *L. variolus* and *L. hesperus* (18 attempts) none of which terminated in an insemination. Three of 27 attempts between *L. mactans* and *L. hesperus* were successful, but there was no development of eggs laid by these females.

CONSTRUCTION OF THE EGG SACS

Whereas the egg sacs of the three species vary somewhat in size, shape, and color, they all appear to be of tough papery texture, usually only slightly translucent. In this respect they are similar to the sac of *L. bishopi*, but quite different from that of *L. geometricus*, which is non-papery and quite translucent. Sacs made by virgin females may be abnormal (Kaston, 1968). The sacs of *L. hesperus* and *L. variolus* are pear-shaped (Fig. 14g), and often somewhat spread at the top, about 13 or 14 mm in height and about 10 or 12 mm in diameter. Those of *L. hesperus* are most often creamy yellow to light tan, those of *L. variolus* light tan with most often a tinge of gray. The sacs of *L. mactans* almost always show the gray tinge and often are quite decidedly gray, even when freshly made. Also, they are more nearly spherical, about 11 or 12 mm in diameter, and with a conspicuous nipple at the top (Fig. 14h).

At times the sacs do not show the typical color. McCrone and Levi (1964) indicated that sacs of *L. bishopi* differ from those of *L. mactans* in having a soft texture and being white in color. But the sacs of *L. bishopi* I have seen are just as papery as those of *L. mactans* and are light tan. The sacs of *L. geometricus* are studded with conspicuous pom-poms, whereas the other species make sacs without these surface features. But Abalos (1962) and Abalos and Baez (1967) indicate that apparently there is a species in Argentina (their *Latrodectus* No. 2) which does have pom-poms on the surface, albeit they are smaller and less conspicuous than those of *L. geometricus*. Likewise, occasional sacs made by *L. variolus* appear to have very small, irregularly distributed, whitish pom-poms showing up against the gray surface. This has been observed with specimens from Arkansas, Michigan and Missouri.

Nearly all of the hundreds of egg sacs made in the laboratory were made during the night. However, of those made in daylight four of *L. hesperus* were begun after noon, and 27 before noon; five of *L. mactans* were made in the morning and one in the afternoon; and for *L. variolus* four were made before noon. The behavior is about the same in all three species, and the construction may be conveniently divided into four steps.

The egg sac is begun with the laying down in step I of the canopy, a small circular sheet, which is gradually enlarged so that its diameter is about that of the completed sac. As the spider finishes the periphery of the disc she also slowly pulls it into the shape of a shallow cone with a slight peak. The duration of step I averages about 23 minutes.

Proceeding to step II the spider stands under the canopy and extrudes the mass of eggs. This is done with rapid upward jerks of the abdomen at the rate of about 100 to 120 times per minute. The jerking expels the eggs and colleterial fluid which cements them together, and also pushes the eggs higher toward the canopy. This step averages about 11 minutes.

The female next begins spinning a transparent layer of gauzy silk around and under

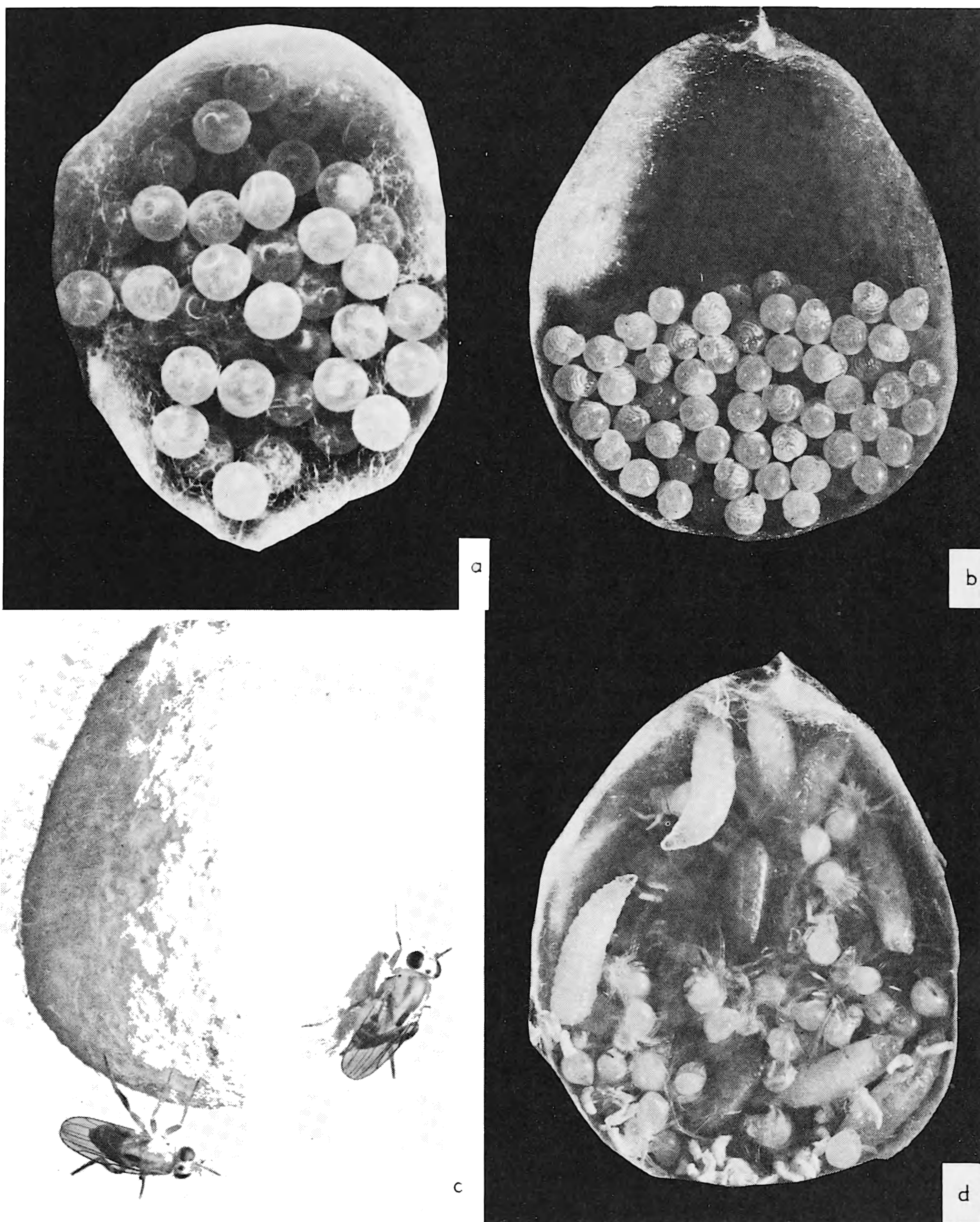

Figure 16. Egg sacs of *L. hesperus* from California. a, sac opened to show eggs shortly after oviposition; b, embryos ready to hatch; c, adult fly parasites, *Pseudogaurax signata*, on egg sac; d, maggots and puparia of *Pseudogaurax* among spiderlings.

the egg mass, and about 5 or 6 mm from it. She works from the canopy downward and finishes at the bottom where the egg mass usually soon comes to lie (Fig. 21b). The egg mass itself comes to occupy one-half to two-thirds the volume of the sac. This step III averages about 25 minutes.

The final action, in step IV, consists of covering the sac with tough, more or less opaque papery silk, and averages about 100 minutes. During the first 10 to 15 minutes of this period the spider walks around over the sac, drawing out silk with her hind legs and tapping with her spinnerets at the rate of 60 times per minute. Later, the hind legs are no

longer used, but rather, the silk is applied directly each time the spinnerets touch the sac, now at the rate of about 120 times per minute. Since the abdomen is brought up to the sac a distance of several millimeters it is this length of thread which is applied each time a tap is made. The rate of tapping may rise to 150 and even 200 times per minute (in one case to 240) as the work continues. At intervals she turns the sac about. During the final 30 minutes or so she stops for several brief rests.

The sac is ordinarily suspended in the snare (Fig. 21a), in or near the retreat if one is built. Sometimes eggs are laid without any sac whatever. They are merely dropped to the bottom of the cage. Rarely this behavior is displayed by impregnated females; more usually by virgins.

NUMBER OF EGG SACS AND FECUNDITY

The interval between copulation and the production of the first egg sac varies considerably. While Abalos and Baez (1967) found this interval to be 7 days for *L. geometricus*, and Miller (1947) found it to be 61 days for *L. hesperus*, the period noted by D'Amour et al. for this latter species was over a year. My own records show for *L. hesperus* that the shortest time was 7 and the longest was 305 days; for *L. mactans* 16 and 22 days; and for *L. variolus* 14 and 27 days respectively.

Black widow females are capable of making many egg sacs. The highest number reported is 29 for *L. geometricus* by Bouillon (1957a). According to Burt (1935), Illingworth reported 15 for *L. mactans*; nine is the maximum reported for *L. indistinctus* by Smithers (1944), for *L. hesperus* by Chamberlin and Ivie (1935), and for *L. curacaviensis* by Bücherl (1969); and eight for *L. tredecimguttatus* by Juberthie (1954). My own observations indicate up to 6 for *L. variolus*, 10 for *L. mactans*, and 21 for *L. hesperus*. Since I had relatively few specimens of *L. variolus*, and had them for a relatively short time, I cannot be sure of the significance of the figure for that species. But there were a sufficient number of specimens of *L. mactans*, and they were maintained for a sufficiently long time so that it may be safely said that there are fewer egg sacs made by this species than by *L. hesperus*. However, they lay more eggs per sac on the average, the mean for 185 sacs being 255 eggs, while for *L. hesperus* the mean of 464 sacs was 196 eggs.

A maximum of 5761 eggs laid by a single female of *L. geometricus* was reported by Bouillon (1957a). For *L. mactans* I found that the greatest productivity was 2132 eggs in the nine sacs made by #1221. The largest number of eggs per sac was 919, followed by 530, 435, and only a few sacs with over 300. The most common range was 215 to 237. There was one sac with a single egg, and five others with fewer than 100. For *L. hesperus* the largest number of eggs per sac was 598, and the same female produced a sac with 527. The next highest was 427, and very few sacs had over 300. Commonly the range was 160 to 225. There was one sac with a single egg, and five others with fewer than 10 eggs each. The greatest productivity was 3024 eggs for the 12 sacs made by #1002. The largest number of eggs laid in one sac by *L. variolus* was 315, and the mean for 34 sacs was 164 eggs.

Baerg (1945, 1959) reported *L. mactans* females producing four to nine sacs with the largest number of eggs in the early ones, and fewer in the later ones, the last one or two often being empty. I did not find this to be the case. The number varied from one sac to the next, sometimes smaller, and other times larger.

Bouillon and Lekie (1961) noted that in *L. geometricus* eggs were laid at intervals of four days for the first few sacs, but the intervals became progressively longer. On the other hand I found that the intervals between successive sacs varied widely. The shortest period for *L. hesperus* was six days between the eighth and ninth sacs made by #2130; the longest was 332 days between the second and third sacs made by #1069. For *L. mactans* the

shortest interval was six days between the second and third sacs of #1147; the longest was 190 days between the first and second sacs of #1192. For *L. variolus* the shortest was 13 days between the second and third sacs of #1376, and the longest was 113 days between the third and fourth sacs of the same spider. No trend for either increasing or decreasing the interval can be seen from the data, and as can be seen from table 1 the coefficient of variability indicates wide variation in the spacing of sacs.

Table 1. *Interval between ovipositions.*

		Number of Females	Number of Sacs	Interval; in days			Coeff. of Variation
				Range	Mean	S.D.	
<i>L. variolus</i>	Virgin	4	7	17-86	28.9	± 25.6	88.6
	Non-Virgin	11	20	13-114	30.0	± 29.5	98.3
<i>L. mactans</i>	Virgin	5	10	13-190	40.0	±171.8	429.5
	Non-Virgin	43	128	6-190	33.5	± 29.0	86.6
<i>L. hesperus</i>	Virgin	48	156	1-332	49.5	±175.8	355.2
	Non-Virgin	109	672	7-305	34.8	± 29.7	85.3

Naturally one could hardly expect that all the eggs laid would actually develop. Very few sacs showed a development of 100% of the eggs. However, it would be reasonable to expect that those sacs produced early in a series would show a higher percentage of fertility than those made later. Sometimes the first five to seven sacs from a single female showed a fertility percentage of 98 or 99. Though one would expect that later sacs might show an increasingly lower fertility this did not follow in any regular manner. For example, for *L. hesperus* #2130 the first five sacs showed over 90% development from each. From the sixth sac only 30% of the eggs developed, yet the next six sacs averaged a development of over 90% again! The 13th (and final) sac had 78% of the eggs developed. There were many other instances where a sac would show no development whatsoever, then later sacs show a fairly high percent of fertility. I could find no pattern of increasing or decreasing fertility.

Usually, when a large number of eggs is laid and only a few develop, the spiderlings do not emerge from the sac. There are exceptions, an outstanding one being the case of egg sac #1050-B, of *L. hesperus*, where of the 208 eggs laid only one developed, but the spiderling emerged.

A Connecticut specimen, presumably of *L. variolus*, mature when collected on 10 April 1949, produced an egg sac on 17 June 1950 from which spiderlings emerged. Since the female had not been mated in the laboratory at least 434 days had elapsed from the time of mating to the time of fertilization. This longevity of sperm cells, which is considerably greater than that of the male spider that made them, is exceeded in two instances by *L. hesperus*. One #1053, collected already mature on 6 December 1965 produced her fourteenth egg sac on 4 February 1967, from which spiderlings emerged. Thus the sperm cells remained viable for at least 455 days. Also, #1202, collected already mature on 12 December 1966 produced her fourteenth sac on 24 April 1968. Of the 170 eggs laid, 36 developed into spiderlings, indicating that sperms had lived at least 499 days after insemination. Actually the correct figure is nearer 600 days, for this female at the time of collection already had five egg sacs in her web.

DEVELOPMENT WITHIN THE EGG SAC

In all three species the eggs may be occasionally lavender-pink or mauve. However, most often they are creamy white to yellow, and sometimes orange. The same sac may contain eggs of more than one color but the further development bears no relation to the color. The eggs are spherical, or almost so; those of *L. mactans* average about 0.95 mm in diameter; of *L. hesperus* about 1.1 mm, and of *L. variolus* about 1.2 mm in diameter.

To obtain data on pre-emergence development many sacs were opened (Fig. 16a) within a day of oviposition. These sacs were placed in vials of which the plugs were kept moistened to protect the eggs from total drying. Within a day of oviposition the eggs dried sufficiently to roll around freely. If dropped on a hard surface they would bounce and roll, seemingly without injury.

Although Baerg (1945) reported hatching in *L. mactans* after only 8 days, in my experience the hatching time for all three species was nearer two weeks. The average time in days was 13.4 ± 2.0 for *L. variolus*, 14.2 ± 1.4 for *L. mactans*, and 14.6 ± 2.0 for *L. hesperus*. About a day or so before hatching the membranous surface of the egg becomes wrinkled, and one can see the outlines of the cephalothorax and appendages as bulges (Fig. 16b). The newly hatched spiderlings are entirely unpigmented, without eyes or hairs, and they move feebly. Within a day after hatching the first sign of pigmentation appears as a ring at the periphery of each anterior median eye. The six indirect eyes begin to develop their pigment a day or so later. Also, about this time, fine black hairs begin to show up on the dorsum and legs. In addition, the legs show a slight yellowing. That the spiderlings undergo their first molt inside the sac was first reported by Rau (1924) and this occurs about three or four days after hatching.

During the next five to seven days, pigment is gradually deposited in the characteristic pattern. Also, the spinnerets develop to the point where they can function, so that by the end of this period the spiderling begins to spin silk as it crawls about among its fellows in the sac. Twenty to 23 days after oviposition the youngsters appear ready to emerge from the sac. However, the actual emergence does not usually take place for another few days, during which time there is somewhat more pigment deposited in the pattern. The average time, in days, from oviposition to emergence was 26.2 ± 2.2 for *L. variolus*, 29.1 ± 3.0 for *L. mactans*, and 30.3 ± 2.8 for *L. hesperus*.

EMERGENCE

An emergence hole is visible about a day or so before the spiderlings actually emerge. The hole is made by cutting with the chelicerae, and possibly also by digesting away the silk by regurgitated proteolytic enzymes. At least I have seen what appears to be a moistened area on the silk as the chelicerae are worked around enlarging the hole. Ordinarily a single hole is cut allowing escape of the spiderlings. This hole, about 1 mm in diameter, may be made by one spiderling, or by two working together. A few sacs have been found with two exit holes, and rarely with three.

If, after the escape of one or more spiderlings, the exit hole is now covered over or plugged with glue, a new hole will be made by the remaining spiderlings. Even a third hole will be made if the second is plugged. On the other hand some sacs remained unopened, and the spiderlings were later found dead in the sac, e.g., #1374-B of *L. variolus* from Michigan, #1380-B of *L. mactans* from Missouri, and #1415-A of *L. hesperus* from Texas. In a few sacs spiderlings did not emerge but nevertheless grew and molted, in one case to within one instar of maturity (Kaston, 1968). In another sac, of *L. mactans* from Illinois #1283-B, there was no emergence six months after the eggs were laid. In the sac

THIS PAGE IS LOCKED TO FREE MEMBERS
Purchase full membership to immediately unlock this page

FORGOTTEN BOOKS

FULL MEMBERSHIP

797,885 Books!
All you can read
for only
\$8.99/month

Continue

*Fair usage policy applies



nourishment during this time. At any rate, those spiderlings which were not fed during the first instar, and yet molted, changed very little.

Still another type of variation is geographic. This had been recently demonstrated for Peruvian specimens of *L. mactans*, by McCrone and Levi (1966), and it had been noted by others as well. Smithers (1944) encountered it in his studies on *L. indistinctus* in South Africa, and I have seen many examples of it in our three species from all over the United States.

To some extent the appearance of the adult is correlated with the instar in which the individual matured. Those maturing in later instars may be darker than those maturing in earlier. However, this is not absolute, and I have found that many specimens maturing in the sixth, seventh, and eighth instars cannot be told apart. McCrone and Levi (1964) reported "noting a striking correlation between total length of the spider and the coloration of different forms, the smaller being brightly colored, the largest ones dark." This correlation seems high, but it is not perfect. Also, smaller specimens can be lacking in red markings as much as larger specimens.

Latrodectus mactans

FIRST INSTAR (Figs. 17a, b). — The carapace is mostly yellowish suffused with gray, with black around the eyes, and with black marginal and median stripes. The sternum is yellow with a very thin marginal black stripe. The legs are yellowish orange, at most only very faintly annulate with dusky, but usually somewhat grayer toward the distal ends of the tarsi.

The abdomen is orange-red, with a pair of anterior white bands, often joined across the front as a single "chevron" mark, a median white band, and two pairs of diagonal white bands extending laterally. The median band may be divided into two, three, or four spots, by encroachments, at intervals, of the orange-red ground color. In many specimens the white lateral bands are bordered along the posterior edges by a line of black pigment. There may also be thin black lines along the sides of the median light band. But many in the same brood of spiderlings show no black at all in this stage.

There is a conspicuous black spot covering the spinnerets and anal tubercle. Many specimens already show an indication of an hourglass mark, but with others the reddish orange pigment seems evenly distributed over the venter and sides.

SECOND INSTAR (Figs. 17c, d). — The general impression is that there has been a marked change from the first instar, with much black pigment deposited. On the carapace the dark marginal bands are broader, and even the light areas are suffused with gray. The sternum likewise is darker. On the legs the annuli are now distinct. Leg I has the femur with the basal half dark, and the distal half light, except for a small dark ring at the apex; the patella is suffused with gray; the tibia has a dark ring at each end, and one just about at its middle; the metatarsus and tarsus are without dark annuli. Leg II has the femur yellow, except for a small dark ring at the apex; the patella has a faint indication of a dark ring distally; the remaining segments are like those on leg I. Leg III has the femur with a dark ring at the apex, and a dark ring at each end of the tibia; otherwise it is like leg I. Leg IV has the femur with a dark area occupying the middle half of the prolateral surface, then a ring at the apex; the patella has a distal dark ring; and the remaining segments are like those on leg I.

On the dorsum black bands alternate on each side with creamy white areas (Fig. 17c). There is almost always a light median spot, followed by a light median band, which however, may be broken into spots. In some specimens these white areas have a little orange pigment in their centers. The venter plainly shows the hourglass mark, which is

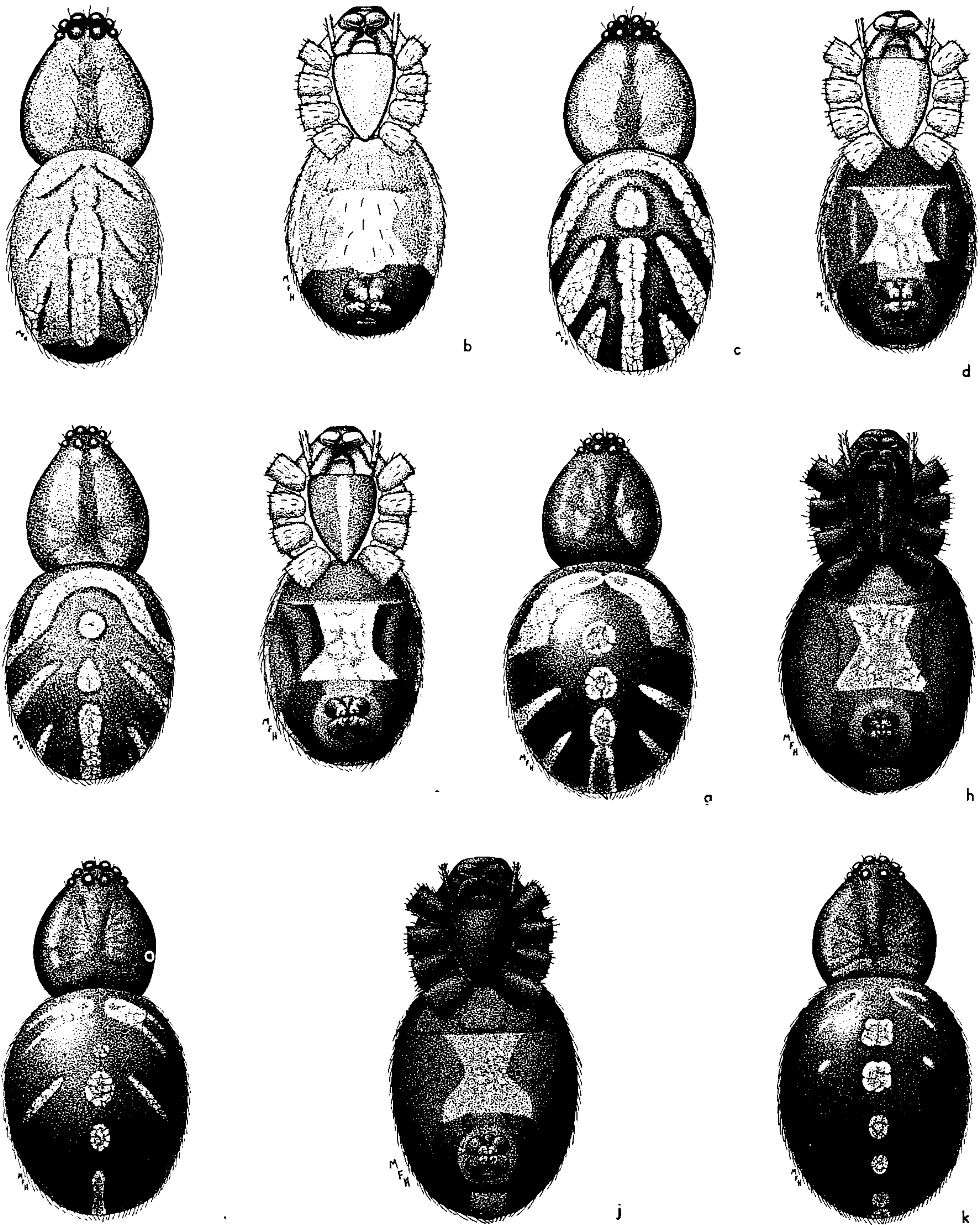

Figure 17. Postembryonic development stages of *L. mactans*. a, first instar, dorsal aspect; b, the same, ventral aspect; c, second instar, dorsal aspect; d, the same, ventral aspect; e, third instar, dorsal aspect; f, the same, ventral aspect; g, fourth instar, dorsal aspect; h, the same, ventral aspect; i, fifth instar, dorsal aspect; j, the same, ventral aspect; k, sixth instar, dorsal aspect.

much more constricted in the middle than with *L. hesperus*.

THIRD INSTAR (Figs. 17e, f). — The gray areas are now larger on the carapace as well as on the sternum, where the light area is reduced to a median narrow stripe. The legs are much darker, though annuli are still visible. The most noticeable change is on the abdomen, where the black areas are much larger, with the consequent decrease in size of the light areas. This is particularly noticeable in the mid-dorsal stripe, which is now broken up into more spots. The hourglass mark is more distinct, and is bordered with black. In

some individuals it is quite red, in others it is almost white.

There is a great deal of variation. Some individuals look much like those in the second instar, and others like those in the fourth. The degree of blackness varies widely. Some have the white areas quite restricted; some show only black and white, but no red on the dorsum; others show only black and red, with no white on the dorsum.

FOURTH INSTAR (Figs. 17g, h). — The carapace is darker. The midline stripe on the sternum is narrower. The legs have changed little, but the dark areas are a bit more extensive. The abdominal dorsum shows the light areas still further reduced in size. Of those specimens with white, rather than red, spots, most show orange pigment in the centers of these white spots. As in the preceding instar there is considerable variation, many specimens looking like third and many like fifth instar individuals. Many males show by the enlargement of the palpal tarsus that they are in the penultimate instar.

FIFTH INSTAR (Figs. 17i, j). — There is relatively little change from the previous stage, with a continuation of the overall darkening, as the black pigment spreads. The legs are still banded. On the dorsum the white diagonal bands are thinner and shorter, and often the third (or most posterior) pair is absent.

SIXTH INSTAR (Fig. 17k). — The carapace is quite black. The legs are almost all black, with the former light areas being dark brown. However, some specimens may show the annuli slightly. On the dorsum the white diagonal bands are very much reduced; the first as a small chevron mark, and the second as a faint remnant. Sometimes the chevron is represented as a pair of red spots. The spots of the median row are now bright red. In many specimens the spots tend to disappear from anterior to posterior so that in some there remains only the most posterior spot just above the anal tubercle. Some of the females mature in this instar.

SEVENTH, EIGHTH AND NINTH INSTARS. — Most females mature in these instars. There is usually only a remnant of the chevron mark at the front of the dorsum. The diagonal light bands have disappeared entirely, or are at most only very faint, so that the only spots remaining are the red ones of the median row, and even these may be reduced to just one above the anal tubercle. The hourglass mark usually consists of an anterior triangle and a narrower posterior rectangle with rounded corners.

Latrodectus hesperus

FIRST INSTAR (Figs. 18a, b). — The ground color of the carapace is dusky grayish yellow. However, the eye region is black, and there are three black longitudinal stripes. One of these extends from the median eyes to the rear; the other two are along the lateral margins. The sternum has similar marginal bands, but is otherwise dusky yellow. The legs have the same ground color as the carapace. Leg III is much less pigmented than the others, and is dark only at the distal end of the tarsus. The other legs show a dark ring at the distal ends of femur, patella, tibia, metatarsus and tarsus, as well as a ring at the proximal end and middle of the tibia.

The ground color of the abdomen is creamy white, some specimens showing a light tan to olive-green hue toward the sides. There are two rows of black spots extending along the dorsum, four to six spots in each row. Between these two rows many specimens show two rows of very narrow lineate black spots, sometimes only on the anterior half. On the ventral side one can see two black spots on either side of the spinnerets. Between the epigastric furrow and the base of the spinnerets is a more or less rectangular yellow area where the hourglass mark will appear in later instars. At this stage it is barely pinched in at the middle.

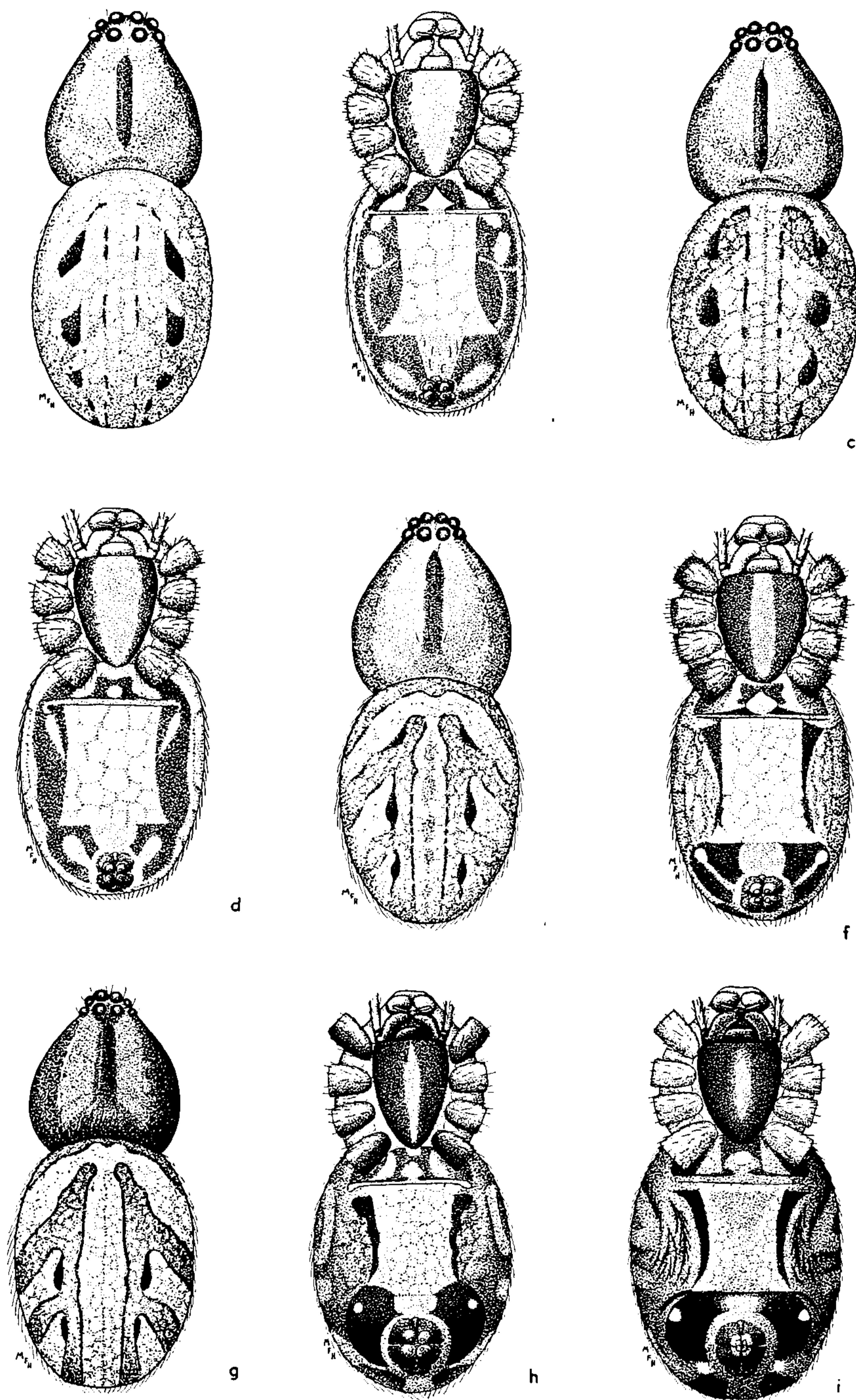

Figure 18. Postembryonic developmental stages of *L. hesperus*. a, first instar, dorsal aspect; b, the same, ventral aspect; c, second instar, dorsal aspect; d, the same, ventral aspect; e, third instar, dorsal aspect; f, the same, ventral aspect; g, fourth instar, dorsal aspect; h, the same, ventral aspect; i, fifth instar, ventral aspect.

SECOND INSTAR (Figs. 18c, d). — The dark lines on the carapace have become a trifle wider and the legs a bit darker, with leg III beginning to show annuli like the others. The greatest amount of change is on the abdominal dorsum where there is a suffusing of gray pigment on the sides of the dorsum that extends down laterally. In some specimens the black spots are larger than they were in the previous instar, but in others they have become incorporated into two faintly discernible olive bands. A similarly colored band begins to appear encircling the dorsum up front.

THIRD INSTAR (Figs. 18e, f). — On the carapace the marginal dark bands have widened. The marginal dark bands of the sternum have become wider than the median yellow area.

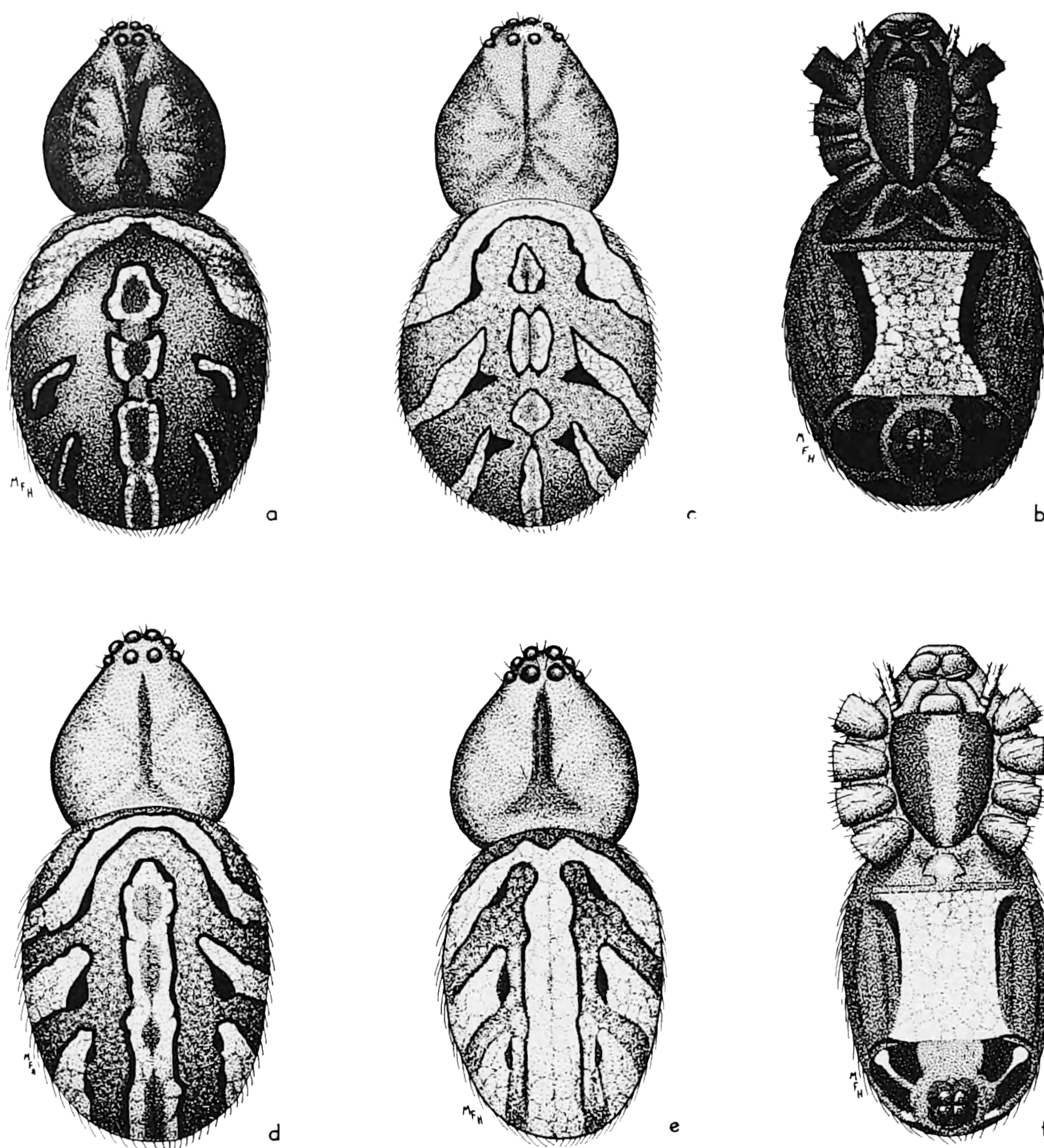

Figure 19. Postembryonic developmental stages of *L. hesperus*. a, sixth instar female, dorsal aspect of a dark specimen from El Centro, California; b, the same specimen, ventral aspect; c, sixth instar female, dorsal aspect of a light specimen from Riverside, California; d, fifth instar female, dorsal aspect; e, fourth instar, penultimate male, dorsal aspect; f, the same, ventral aspect.

The dorsum now distinctly shows the pair of longitudinal bands, olive gray, one on either side of the midline, with a branch on each side from the anterior end and another such branch from just behind the middle. Each of these branches extends diagonally back to the side. The anterior encircling band is now more pronounced, so that from the side one now sees these bands extending down obliquely to the rear. Besides these there is the band extending straight back, closer to, and parallel to, the midline. Thus there are three light areas on each side, as well as the median one. In many specimens a little orange pigment begins to form along the center of this median one. There are still remnants of the original black spots, though these are now blended in with the olive gray bands. In the *texanus* variety these latter bands are often pink. On the venter the two black spots on either side of the spinnerets are quite conspicuous. The hourglass mark now shows tinges of orange, and to each side of it a black line has developed.

FOURTH INSTAR (Figs. 18g, h). — There is a light variety, members of which are hardly distinguishable from the third instar. Often males are recognizable now as in the penultimate instar (see below) and they are usually of the light variety (Figs. 19e, f). For the dark variety one notes that on the sternum and carapace the areas covered by the black bands have enlarged, and the median band of the carapace has widened behind.

The abdominal dorsum now shows the pattern of bands much more distinct, with more gray mixed in with the olive and usually with somewhat more orange pigment along the midline. In some specimens the light areas between the bands show some orange

pigment, and the bands are brownish gray. The hourglass mark shows a little more orange pigment along its middle.

Some males mature in this instar.

FIFTH INSTAR (Figs. 18i, 19d). — The carapace is not much different from that in the fourth instar, though the sternum shows the light central area still further reduced. The legs still show some of the annuli faintly, but they are getting darker, and on the tibiae the central and distal rings have come together to form one large ring. On the abdominal dorsum the dark bands are wider, so that now the median light stripe is narrower than they are. For the dorsum as a whole there is a much larger surface covered by the gray bands than by the light areas. The gray areas are outlined in black. A row of orange spots now appears in the median light stripe. The orange pigment in the hourglass mark is deeper in the front and back halves, with hardly any in the central portion.

Some males mature in this instar; and those maturing later seem nevertheless to retain the markings of this fifth instar. They hardly change although a few seem to get a little darker. I have examined many specimens that matured in this, in the sixth, and in the seventh instars, and contrary to ideas I formerly held I was unable to note any significant differences in their appearance.

SIXTH INSTAR (Figs. 19a, b, c). — The darker specimens show more pigment on the carapace and have the dark areas more extensive than previously. There remains on the sternum only a narrow central light band. On the legs the dark areas have increased in size.

The abdominal dorsum is mostly covered with dark pigment now, with the only light areas reduced to a basal transverse band, a row of spots along the midline, and two pairs of diagonal stripes extending down the sides to the rear. These latter are the areas that had previously been wide, between the dark areas that had previously been narrow. Each of the light spots along the midline encloses a reddish spot. The hourglass mark is becoming more constricted at the middle and has more red pigment.

Some individuals, showing a more or less similar arrangement of spots, have the pigmented areas lighter. Also, the light diagonal bands extend farther down on the sides, and the dorsal spots are more orange than red.

SEVENTH, EIGHTH AND NINTH INSTARS. — Most females mature in these instars. While I had previously supposed that those maturing in the later instars would show more of the black pigment, and smaller areas of light pigment a comparison of many specimens revealed that (as was the case with the mature males) there is no significant difference in their appearance. A female maturing in the seventh instar may look quite similar to one maturing in the ninth. This, of course, does not preclude the possibility of changes occurring during the instar. Some males mature in the sixth and seventh instars, and in general they resemble a female in the fifth or sixth, of the light variety. Some males are darker. The legs retain the annuli, which are often more conspicuous than those in young females, and often without the fusion of middle and proximal rings on the tibiae.

Latrodectus variolus

FIRST INSTAR (Figs. 20a, b). — The carapace is reddish orange to brownish orange, with the eye region black. The median and marginal dark bands so noticeable in the other two species are lacking. The sternum is about the same color with the margins somewhat dusky. The legs show the same ground color as the carapace, but there are faintly indicated annuli. These appear on legs I, II, and IV at the distal ends of patella, tibia and metatarsus, with those on leg I slightly darker. Leg III is like leg I but the annulus is absent from the metatarsus.

The ground color of the abdomen is reddish orange. There is a large black area around the spinnerets and anal tubercle, and there are three pairs of large black spots on the dorsum. The dorsum has white blotches along the middle, and some white extending to the sides in front of each black spot. Where the abdomen overhangs the carapace is a white transverse band, which extends diagonally to the rear on each side to a pair of white spots farther back. There are three pairs of diagonal white bands. The hourglass mark is not distinct, but some specimens have irregular white blotches in this area.

SECOND INSTAR (Figs. 20c, d, e, f). — This is very similar to the first instar, with the carapace somewhat browner, the black spots on the abdominal dorsum a bit larger, and the hourglass mark showing more white as “cottage cheese” blotches.

THIRD INSTAR (Figs. 20g, h). — The carapace is now more chestnut brown. The legs appear dull orange to chestnut brown, and the annuli are slightly darker. On leg I the basal half of the femur is dark, as are also the distal half of the patella, the distal third of the tibia, and the distal fourth of the metatarsus and tarsus.

The greatest change is seen on the abdomen, which is now black over most of the dorsum. There remain a white band across the front, a median row of white spots, and three pairs of diagonal white bands extending down the sides, so that their lower ends are visible from the ventral aspect. In each median spot is a small spot of orange-red pigment. The hourglass mark is complete, but relatively faint in the middle area.

Specimens that have recently molted to the third instar often show the black area brownish instead, except for those places where the original six black spots were. But the black pigment suffuses into these brown areas so that later in this stage a larger area looks black.

FOURTH INSTAR (Figs. 20i, j). — The general appearance is much like the third instar. The carapace and legs, however, are more dusky. On the abdominal dorsum the spots of the median row are now red. The basal band and the lateral oblique white bands are narrower and shorter, so that the laterals no longer extend to the ventral side. The hourglass mark is now red, and in most specimens shows a distinct separation into two parts.

FIFTH INSTAR (Figs. 20k, l). — The spiderlings look much like those of the preceding instar, but with the carapace and legs darker. The annuli still show on the latter. The abdominal dorsum has the light areas still further reduced. Nearly all specimens show the hourglass mark divided.

SIXTH INSTAR. — The carapace and legs are dark brown to black, and the leg annuli show plainly. Some males mature in this stage.

SEVENTH, EIGHTH AND NINTH INSTARS. — Females mature in these stages. Illustrations of this species have been published by Judd (1965), Wilson (1967) and, under the name *L. mactans*, by Emerton (1902) and Kaston (1937a, 1948, and 1953).

APOSEMATIC COLORATION

One can see from the above descriptions how different the spiderlings are from the adults. These changes, as the spiderlings grow and molt, were first noted by Dugès (1836) for *L. tredecimguttatus*. Dugès, and also Marikovskii (1947) pointed out how the many different appearances could be responsible for authors describing each stage as a different species, and this, in part, accounts for the long list of synonyms.

Apropos of the changes in color as the spiderlings develop, it should be noted that all three of our North American species acquire more black pigment, and that the hourglass

THIS PAGE IS LOCKED TO FREE MEMBERS
Purchase full membership to immediately unlock this page

DELVE INTO FANTASY, MAGIC, MYTHOLOGY & FOLKLORE

Forgotten Books'
Full Membership gives
access to 797,885 ancient
and modern, fiction and
non-fiction books.

Continue

*Fair usage policy applies

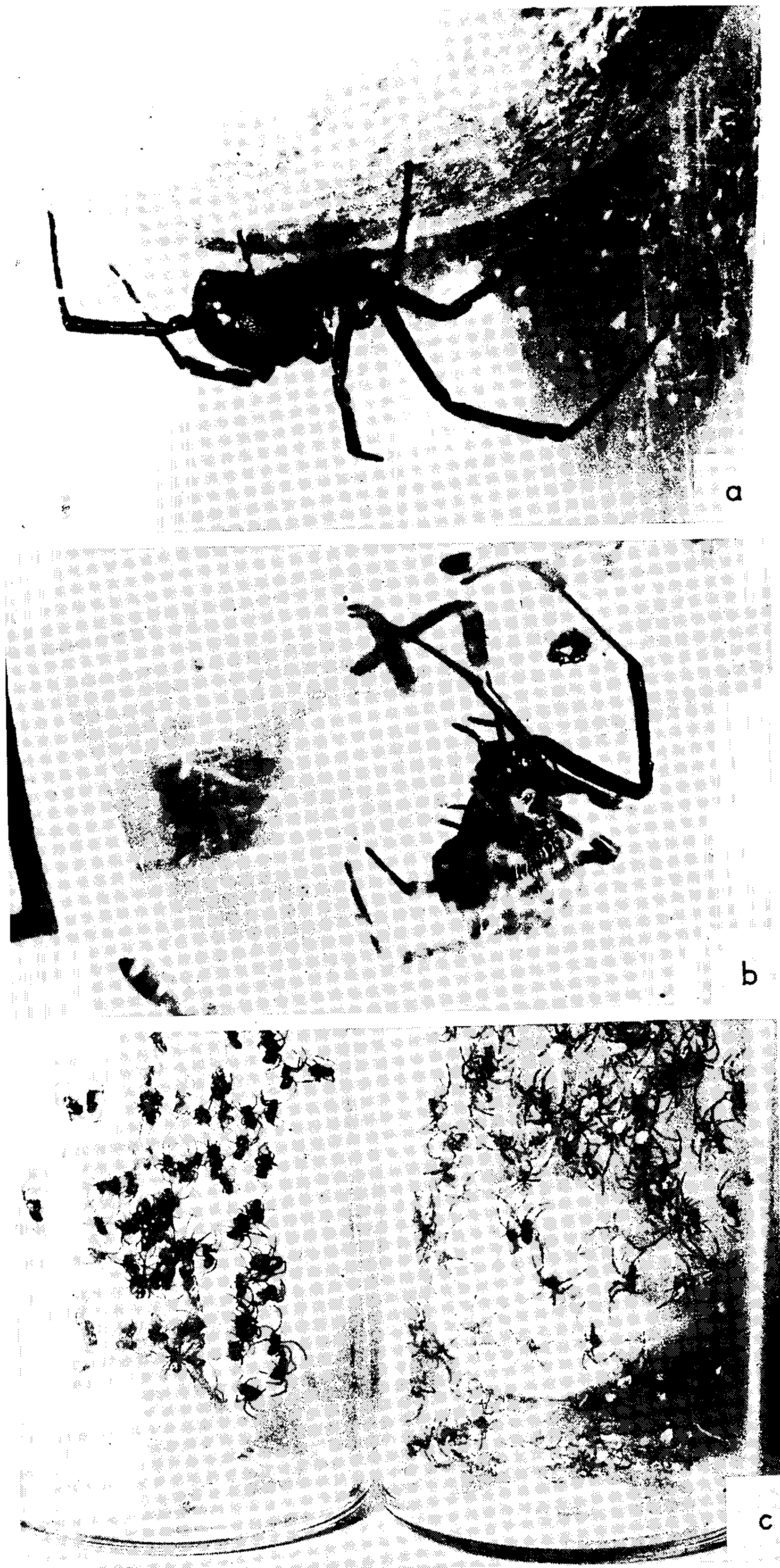

Figure 21. a, *L. hesperus* female from California, with egg sac; b, *L. hesperus* female from Arizona making egg sac; note ball of eggs through semitransparent unfinished sac; c, on left, the egg sac and newly emerged spiderlings of *L. mactans*; on right, the same of *L. hesperus*.

instar.

In *L. variolus* the hourglass mark may appear more "complete" in the young, and usually loses its middle portion in later instars. This has been reported also by Marikovskii (1947) for *L. tredecimguttatus*. Likewise, for *L. indistinctus* Smithers (1944) has shown that an hourglass mark is present in the spiderlings but disappears completely (or almost so) by adulthood. According to Beregovoi (1962), *L. pallidus* has no hourglass mark in any of its stages. Despite Bristowe's remark that *L. geometricus* differs from other members of the genus in not having the hourglass mark, all specimens from Florida and the West Indies that I have seen do possess this mark, and Smithers has observed it in South African members of this species. Moreover, this species has been known to cause envenomation in humans (Finlayson, 1956). Contrary to Bristowe's supposition, it has been known for many years that young individuals and males do have poison, albeit less than mature females. Moreover, even those species without a distinct hourglass may have virulent venom, and may be much feared.

RATE OF DEVELOPMENT AND LONGEVITY

Several observers have supplied information as to the number of molts and the length of time to maturity. Studying the ctenid *Cupiennius salei*, Melchers (1963) found that poorly fed spiderlings matured after fewer molts. Contrariwise, Miyashita (1968) for *Lycosa T-insignata*, and Deevey (1945, 1949) for *Latrodectus mactans* found that those poorly fed required more molts. Well fed spiderlings not only underwent fewer molts but matured in a shorter time. But of course feeding is not the sole factor, and as indicated, wide variations occur even among siblings in the same family when raised under identical conditions.

Even under uniform environmental conditions, there was considerable variation with respect to the number of molts, the intervals between molts, and the length of time it took for the spiders to mature. This variability extended even to "litter-mates" from the same egg sac, and is similar to that found by Deevey (1949), and by Witt and Reed (1965). For example, there is the case of three sisters maturing on the same day, 100 days after emergence, *L. mactans* #1132-A-51 in the sixth instar, #1132-A-57 in the seventh, and #1132-A-59 in the eighth. Sometimes a particular family shows a faster or slower development, or in some other way is different from the average, e.g., some of the *L. variolus* families had all the males ready to mature in the sixth instar, but in other families it was the seventh instar. By far the greater majority of spiderlings failed to mature. This was especially the case with specimens of *L. variolus*, which appear to require a longer time, and most often a greater number of molts than do the other two species. Most of them died in the fourth or fifth instar.

More success was obtained with males than with females, probably in part because males go through fewer instars on the average, and mature earlier. Thus I am unable to understand the remark by Baerg (1923) that males (of Arkansas *L. mactans*) were more difficult to rear than females, nor the statement by Knowlton (1935) that males (of *L. hesperus* in Utah) required a longer time to mature than did females.

For what is undoubtedly *L. hesperus*, data were given by Herms et al. (1935), Chamberlin and Ivie (1935), Knowlton (1935), and Bhatnagar and Rempel (1962). For *L. mactans* proper, data were given by Lawson (1933), Blair (1934), Muma (1944), Deevey (1945, 1949) and McCrone and Levi (1964). The latter also compared the development of *L. mactans* with that of *L. variolus*. For exotic species Smithers (1944) reported for *L. indistinctus*; Bonnet (1938) and Baerg (1954) for *L. geometricus*. For *L. tredecimguttatus* data were given by Juberthie (1954), Shulov (1940) and Marikovskii (1947); and for *L.*

pallidus by Shulov (1940) and by Beregovoi (1962).

Table 2 shows that the number of instars passed through to maturity is quite variable, and about equally variable for *L. mactans* and *L. hesperus*. However, for both sexes, with individuals undergoing the same number of molts, development is somewhat more rapid in *L. mactans*. Also, although females of both species mature in the sixth through ninth instars, more of the *L. mactans* reach maturity in the sixth and seventh (mode is seventh), while more of the *L. hesperus* mature in the eighth or ninth (mode is eighth). The difference between them, however, is not nearly as great as that found by McCrone and Levi (1964) between *L. mactans* and *L. variolus*. Because of my poor success with rearing of *L. variolus*, only relatively few data can be supplied, and these for males primarily. Therefore, for comparison, I am including in Table 3 data about this species from McCrone and Levi, but have rearranged the data to conform to the way these are presented in Table 1. Although I had no males of *L. hesperus* maturing in the eighth instar, two penultimate males from California died in their seventh, and would therefore, had they lived, have matured in the eighth. Also, besides those shown in the table, one *L. mactans* and three *L. hesperus* females died as penultimates in the eighth instar, and would therefore have matured in the ninth instar had they lived.¹

Table 2 shows that for males there is likewise a wide spread of instars, with the fifth the mode in both species. It would appear that the shortest time in which a male can mature is 37 days. However, among *L. hesperus* families for which the records are incomplete, were one Arizona family, and one from British Columbia, in which males matured in 33 days, and a family from Texas in which several males matured in 27 and 28 days. Likewise, although from the table, 177 appears as the longest interval in days to maturity for a *L. mactans* male and 263 days for a *L. mactans* female, I have records of

Table 2. Rate of development of *L. mactans* and *L. hesperus*.

Species	Sex	Instar in which Mated	Number of Individuals	Number of days spent in each instar								No. of days to Maturity			
				1	2	3	4	5	6	7	8	Range	Mean	S.D.	
<i>L. hesperus</i>	Male	4	16	13.6	13.5	28.8							37-139	61.6	±42.4
		5	140	13.9	11.6	19.0	48.0						40-196	99.0	±29.0
		6	88	14.9	10.7	12.6	24.5	42.3					46-210	119.3	±49.0
		7	6	17.0	10.5	11.0	21.0	53.5	27.5				61-214	150.6	±73.5
	Female	6	5	9.6	8.6	12.0	26.8	70.2					73-185	137.1	±42.4
		7	22	11.8	10.0	11.5	29.5	58.3	26.8				75-239	146.9	±38.7
		8	49	12.4	10.3	11.3	22.9	48.9	36.8	26.6			74-325	202.3	±63.9
		9	12	11.7	10.6	14.7	38.0	68.2	50.9	28.6	29.4		102-325	242.0	±81.8
<i>L. mactans</i>	Male	4	13	16.3	13.7	24.2							49-84	54.4	± 9.2
		5	82	12.9	10.7	13.4	26.1						38-138	63.7	±11.8
		6	48	13.4	9.5	11.9	22.3	32.3					49-161	84.3	±16.9
		7	14	10.6	9.1	12.7	13.0	28.8	28.6				74-177	87.7	±42.4
		8	1	11	12	9	6	14	97	17			—	166	—
	Female	6	11	16.6	10.6	13.0	24.4	35.9					62-134	111.7	±18.1
		7	23	12.6	8.6	14.9	15.0	33.3	31.8				64-193	137.9	±41.2
		8	13	11.0	8.9	10.7	19.5	53.4	34.0	23.8			97-263	140.5	±85.4
		9	1	7	14	9	12	24	16	7	18		—	107	—

¹ While this manuscript was in press a female *L. mactans*, #1647-A-119, matured in the tenth instar, 190 days after emergence.

194 for a male and 378 for a female from North Carolina.

Table 3 shows that spiderlings of *L. variolus* spend a much shorter time in the first instar than do spiderlings of the other two species. Table 4 shows that the minimum number of days spent in a given instar tends to increase as the spiderlings get older. For the maximum number of days in a given instar I am unable to find any correlation.

Table 3. *Rate of development of L. variolus.*

Sex	Instar in which would have matured	No. of Ind.	Mean number of days spent in each instar							
			I	II	III	IV	V	VI	VII	VIII
Male	5	10	9.8	12.3	24.0					
	6	75	4.8	11.3	13.3	21.9				
	7	5	5.1	14.6	12.2	18.2	19.2			
	8	2	4.5	18.5	12.0	15.0	15.0	12.0		
Female	6	3	4.0	8.3	9.3	19.7				
	7	4	3.5	6.5	11.5	17.0	38.8			
	8	3	4.5	17.5	11.5	18.5	11.5	26.5		

	Instar in which matured	No. of Ind.	Data below have been taken from McCrone and Levi (1964).								No. of days to maturity
			I	II	III	IV	V	VI	VII	VIII	
Male	6	1	6	12	11	15	87				131
	7	9	5.1	15.1	11.8	13.4	32.6	49.4			129.4
	8	12	5.2	16.5	12.3	10.7	14.1	31.6	38.3		129.7
Female	8	18	6.4	13.8	10.1	13.4	22.6	41.9	43.2		152.4
	9	4	6.3	12.0	9.2	14.0	14.8	25.2	38.5	33.5	153.5

Table 4. *Minimum and maximum number of days spent in each instar.*

	Instar									
	I	II	III	IV	V	VI	VII	VIII		
<i>L. hesperus</i>	1; 49	3; 52	3; 190	5; 147	6; 200	7; 126	11; 99	15; 53		
<i>L. mactans</i>	1; 57	4; 55	4; 112	5; 143	7; 138	10; 97	7; 75			
<i>L. variolus</i>	1; 33	5; 30	6; 48	6; 76	7; 76124					

Table 5 shows that in both sexes *L. hesperus* on the average lives longer than *L. mactans* after becoming mature; for females about one and one-third times and for males about twice as long. Likewise the total life span from the time of emergence is longer, again by more than one and one-third times in females, and about one and one-half times in males. Table 6 shows the maximum number of days that any specimen lived after maturing, and the maximum number for the entire life span after emergence. The female of *L. mactans* which lived 849 days after maturing must have been older than the 858 days, which is the maximum I have noted for another individual. Adding to 849 the 62 days

Table 5. *Life span.*

Species	Sex	Number of individuals	Mean number of days post-maturity	Number of individuals	Mean number of days; emergence to death
<i>L. hesperus</i>	Male	255	46.5 ± 34.6	240	146.1 ± 51.0
	Female	144	277.5 ± 152.6	87	481.0 ± 199.5
<i>L. mactans</i>	Male	158	21.1 ± 12.6	149	90.8 ± 24.0
	Female	62	203.1 ± 141.4	44	369.6 ± 149.0

found minimal for *L. mactans* females to mature, one obtains for this particular individual a life span of at least 911 days.

The longevity of *L. hesperus* and of *L. variolus* thus is greater than that of *L. mactans*. To ascertain whether this hardiness was also a feature of the young, I set out a family of each species right after emergence and kept them without food. Shulov (1940) had found that newly emerged *L. pallidus* spiderlings can live up to 19 days without food. Also, that the spiderlings of *L. tredecimguttatus* can molt to the second instar without their having fed.

My three families included 213 newly emerged spiderlings of *L. mactans* (from egg sac 1377-A collected in Arkansas), 200 spiderlings of *L. hesperus* (from egg sac #1352-B collected in California), and 128 spiderlings of *L. variolus* (from egg sac #1381-A collected in Missouri). From the *L. mactans* family, the first spiderling died two days after emergence, the last 16 days later. The largest number (=54) died on the seventh day after emergence, when a little over one-half their number had died. None had molted to the second instar. From the *L. hesperus* family, the first to die survived 8 days, the last 32 days. The largest number (=28) died 19 days after emergence, when a little over one-half their number had died. Fifteen of them had molted to the second instar, one within a day after emergence and two 10 days after emergence. Those which attained the second instar died from the 19th to the 24th day after emergence. From the *L. variolus* family 36 died the day after emergence, but one survived 37 days. The largest number (=8) to die after the second day succumbed 19 days after emergence, when a little over half had died. Eighteen molted; two of them two days after emergence, and two on the eleventh day after emergence. Those which attained the second instar died from the 12th to the 31st day after emergence. Thus it would appear that *L. variolus* shows the greatest longevity and hardiness, and *L. mactans* the least.

MOLTING

I often saw spiders in the act of molting, but only once was I able to observe the entire

Table 6. *Maximum longevity; in days.*

	<i>L. hesperus</i>		<i>L. mactans</i>		<i>L. variolus</i>	
	Male	Female	Male	Female	Male	Female
Number of days post-maturity						
Number of days post emergence		1049				

*See text for explanation

process from the beginning. The specimen was a female *L. mactans* #1186, molting from the penultimate instar to maturity. In all essentials the process closely resembled that described for *L. hesperus* by Hagstrum (1968).

The spider assumes a position with spinnerets attached to a thread overhead and all legs fully extended, hanging from above. There is slow rhythmic up and down movement of the body, and the carapace splits around its edges. In about five minutes the old carapace comes off from the cephalothorax. During the next half hour the legs are extricated from the old skin, and the abdomen likewise slowly emerges, with the old skin being pushed toward the spinnerets. The shortest legs, II and III, emerge first, and the anterior legs last. When the legs are all out of the old skin, the spider extends them horizontally, and holds them in that position for a while. The entire process took about 30 minutes. The old exuviae are cut out of the web some hours or even days later.

While ordinarily the molt to maturity is the final one, several exceptions have been encountered, and an account has already been published by Kaston (1968), of five instances of post-maturity molting. One additional case can be added here. A mature female *L. hesperus* #1336 which was collected in San Diego, California, on February 16, 1968 molted, on March 8, 1968.

SEX RATIO

Montgomery (1908) supposed that he could sex spiderlings upon their emergence from the egg sac. He took the newly emerged young with high, wide abdomens to be females, those with low and narrow abdomens to be males. On this basis he obtained a ratio of 8.1 males to 1.0 females. He did not rear the spiderlings to verify his prediction.

I too have observed that among the emerging spiderlings some have stout high abdomens, and others had abdomens perhaps half as high and half as wide; but there were also some of intermediate size and form. For one large family of *L. mactans* from Florida, #1005-A, the shape and size was noted for each spiderling that emerged. The development was followed, and the sex ascertained when old enough. Both males and females developed from the spiderlings that had the large abdomens, small abdomens, and intermediate abdomens, so no correlation could be made.

Bonnet (1938) raised a small family of *L. geometricus* and obtained about twice as many males as females. However, Bouillon (1958) working with the same species, but a much larger sample size, found a slightly greater number of females than males. His statistical analysis indicated that the results were consistent with a ratio of 1:1. Likewise Deevey (1949) obtained a 1:1 ratio in *L. mactans*; Herms et al. (1935) had found this to be the case in *L. hesperus*, and McCrone and Levi (1964) likewise obtained this ratio for both *L. variolus* and *L. mactans*.

In my studies the majority of specimens maturing were male. Deevey indicated that when the spiderlings were underfed a higher percentage of males matured. This might possibly be the explanation for some of my results with many spiderlings dying before their sex could be ascertained. However, in about half of the families raised in all three species, the ratios obtained were consistent with the hypothesis of a 1:1 ratio when a chi square analysis at the 5% level of significance was made.

HABITAT AND WEB STRUCTURE

Most members of the genus *Latrodectus* build their webs close to the ground. However, *L. bishopi* builds above ground in palmetto shrubs, and Abalos and Baez (1967) reported their *Latrodectus* #1 as never having been found less than a meter above ground. They also indicated that *L. geometricus* seems to prefer human habitations, and this had

been noted as well by Smithers (1944) and by Lamoral (1968). McCrone and Levi (1964) found *L. variolus* in northwestern Florida high off the ground in trees, but this species in the more northern parts of its range (at least in Arkansas, Missouri, Illinois, Kansas, Michigan, and Connecticut) will be found in leaf litter on the ground in mesic to xeric deciduous forests. Fitch (1963) in Kansas, and I in Connecticut have also seen this species under stones, and in Michigan it has been found under logs, under fence posts, and in the holes made by small mammals in the ground (Wilson, 1967). It may well be, as suggested by Bhatnagar and Rempel (1962) that sympatric populations "tend to differ in their habitat, but the allopatric populations [of *L. mactans* and *L. variolus*] may occur in identical habitats."

The webs of *L. hesperus* have been reported similarly from holes of small mammals (Jellison and Philip, 1935), in other holes of uneven ground, and along roadsides, etc., but also at times in trash, in sheds, sometimes six or more feet above ground level, and along the outside of houses close to the ground level. At times the density of individuals may be quite high where suitable hiding places exist. For example, in one weedy, litter-filled lot in Brawley, California, 100 specimens, adult or nearly so, were obtained in a couple of hours collecting, in an area of 120 by 150 feet.

The female is negatively phototropic and generally hangs in an inverted position under a piece of overhanging board, or clod of earth, or back in her retreat. Thus she is usually not visible during daylight hours. But after dark the spider may move out over the snare, taking a position perhaps several inches in front of the overhang.

Latrodectus mactans has been reported in Louisiana (Gowanlock and Leeper, 1935) and in Maryland (Muma, 1944) from relatively dry situations in piles of stones, in culverts, fence corners, under steps, in burrows of animals, in housings of service meters, etc. I myself have found this species in and around human habitations, in tobacco barns in North Carolina, and corners of rooms and basements in Georgia.

Specimens may be found throughout most of the year, though in those regions with cold winters the spider remains inactive in a retreat under a stone, etc. Since females quite often live more than one year, it would be expected that mature females can be found at any season. On the other hand, males, which have a shorter life, are found mature mainly during the warmer months. I have records of *L. variolus* males being taken in April and May; of *L. mactans* males from May through October; and of *L. hesperus* males from March through October, with the majority in August and September.

As indicated previously, the webs of black widows are of the irregular mesh type. Nevertheless, the webs are not lacking in organization. They have been extensively studied by Szlep (1965, 1967) and also by Lamoral (1968). In all three of our species the spider builds a retreat, or refuge, which in nature would be under a clod of dirt or other overhanging protective structure.

In *L. hesperus* the retreat has a horizontal upper border, and a curved lower border, and leads through a tunnel an inch or so in diameter to a catching sheet. This latter is usually horizontal, or only slightly inclined. Above the sheet is a loosely woven upper and outer portion. Below the sheet are a number of oblique and vertical threads connected to the substratum. These threads are of the "gum-footed" type, with viscid globules arranged for the most part along the lowest three to five mm, but occasionally extending up as much as 30 mm. These viscid globules are usually absent from the middle layer, the catching sheet, and always absent from the retreat itself. While the webs are usually a foot or so across, and equally as high, they can be larger. One web in an unused wooden shed had a catching portion about 30 inches above the ground level, with threads extending to a retreat in the rafters about 12 feet above the ground.

THIS PAGE IS LOCKED TO FREE MEMBERS
Purchase full membership to immediately unlock this page

FORGOTTEN BOOKS

FULL MEMBERSHIP

797,885 Books!
All you can read
for only
\$8.99/month

Continue

*Fair usage policy applies



the hymenopterous parasite about which most is known is the scelionid, *Baeus latroecti* Dozier, reported by Pierce (1942) from the egg sacs of *L. hesperus* in California. Also, from sacs of the latter species Herms et al. (1935) reared the egg predator *Gelis* sp., an ichneumonid.

As for the predators, one notices in the laboratory occasional instances of a mealworm, *Tenebrio molitor*, eating a black widow. Probably this is managed when the spider is molting (Deevey, 1949), or else moribund, and thus helpless to defend itself. Pierce (1942) and Branch (1943) for *L. hesperus*, and Archer (1947) for *L. mactans*, have observed that black widow spiders are eaten by the related theridiid spider, *Steatoda grossa* (C. L. Koch). Archer also noted that the pirate spider, *Mimetus* sp. attacked *L. mactans* in Alabama, and I have seen *Mimetus hesperus* Chamberlin feeding on *L. hesperus* in California.

Cowles (1937) considered that the San Diego alligator lizard was an effective predator, but, as pointed out by Irving and Hinman (1935) perhaps the most effective, and certainly the most wide-spread predator, is the blue mud-daubing wasp, *Chalybion californicum* (Saussure). Rau (1935) had observed in Missouri that this wasp preferentially provisions its mud cells with *L. mactans* rather than with other spiders. D'Amour et al. (1936) had noted the same for *L. hesperus* in Colorado, and I have observed the same for *L. mactans* in Georgia, as well as for *L. variolus* in Connecticut.

ACKNOWLEDGMENTS

These studies were carried out with the aid of a National Institutes of Health grant No. GM 14623, and a faculty grant-in-aid from the San Diego State College Foundation, both here gratefully acknowledged. I extend thanks to those who helped me obtain live specimens from the following States and Provinces: from Alberta, P. E. Blakely; Alabama, J. D. Unzicker; Arizona, V. D. Roth, F. E. Russell, and W. J. Gertsch; Arkansas, Maxine Hite; Baja California, J. Y. Sandoval; British Columbia, E. Thorn, and L. C. Curtis; California, M. H. Stewart, M. E. Thompson, F. E. Russell, and M. H. Stetson; Florida, J. F. Anderson, J. A. Beatty, and J. D. McCrone; Georgia, J. R. Gorham and B. M. Furlow; Illinois, J. M. Nelson; Kansas, D. E. Gates; Louisiana, K. W. McCain; Michigan, L. A. Wilson; Mississippi, L. R. Roddy; Missouri, H. E. Frizzell, and W. C. Peck; North Carolina, J. J. Moore; New Jersey, R. C. Kern; New York, Arthur Bordes; Ohio, C. Oehler; Oklahoma, John Taylor; Oregon, J. Anderson; Tennessee, B. C. Moulder; Texas, B. R. Vogel, and R. W. Mitchell; Virginia, R. E. Ailstock, and J. E. Carico; Washington, Wyatt Cone; and West Virginia, W. Shear. The drawings were done chiefly by M. H. Stewart and B. R. Burnett. I was able to see the types of *L. hesperus* through the kindness of Dr. W. J. Gertsch. I owe thanks to Professor L. A. Fetzer for the translation of Russian literature, and to Steve Sitko, Joseph Y. Sandoval, and Bruce A. Richardson for their technical assistance.

LITERATURE CITED²

- Abalos, J. W.
1962. The egg sac in the identification of species of *Latrodectus*. *Psyche* 69:268-270.
- Abalos, J. W. and E. C. Baez
1963. On spermatic transmission in spiders. *Ibid.* 70:197-207.
1967. The spider genus *Latrodectus* in Santiago dell Estero, Argentina. *In*, Animal Toxins, New York, Pergamon Press, p. 59-74.
- Archer, A. F.
1947. The Theridiidae or comb-footed spiders of Alabama. *Alabama Mus. Nat. Hist.*, Paper no. 22:5-67.
- Bacetti, B., R. Dallai and F. Rosati
1970. The spermatozoon of Arthropoda. VIII. The 9 + 3 flagellum of spider sperm cells. *J. Cell Biol.* 44:681-682.

²A book about black widow spiders often cited is that by R. W. Thorp and W. D. Woodson, 1945, *Black Widow, America's most poisonous spider*. Chapel Hill, University of North Carolina Press, 220 p. While it is true that it does give much information, all of it gleaned from the observations of others, numerous errors and contradictions are included. The authors are entirely without scientific training, and for various phenomena concerning black widows have supplied peculiar interpretations, some quite teleological.

- Baerg, W. J.
 1923. The black widow: its life history and the effects of its poison. *Sci. Monthly* 17:535-547.
 1945. The black widow and the tarantula. *Trans. Connecticut Acad. Sci.* 36:99-111.
 1954. The brown widow and black widow spiders in Jamaica. *Ann. Entomol. Soc. America* 47:52-60.
 1959. The black widow and five other venomous spiders in the United States. *Univ. Arkansas Agr. Exp. Sta. Bull.* 608, 43 p.
- Beregovoi, V. E.
 1962. Contribution to the study of *Latrodectus pallidus* O. Cambr. subsp. *pavlovskyi* Charit. *Zool. Zhur.* 41:528-538 (in Russian).
- Bertkau, P.
 1875. Ueber den Generations-apparat der Araneiden. *Arch. f. Naturgesch.* 41:235-263.
- Bhatnagar, H. D. S. and J. G. Rempel
 1962. The structure, function, and postembryonic development of the male and female copulatory organs of the black widow spider, *Latrodectus*. *Canadian J. Zool.* 40:465-510.
- Blair, A. W.
 1934. Life history of *Latrodectus mactans*. *Arch. Intern. Med.* 54:844-850.
- Bonnet, P.
 1938. Élevage de *Latrodectus geometricus*. *Bull. Soc. Hist. Nat. Toulouse* 62:171-178.
 1957. (*Latrodectus*) Bibliographia Araneorum. *Toulouse, L'Imprimerie Douladoure* 2:2364-2383.
- Bouillon, A.
 1957a. La fécondité chez l'araignée *Latrodectus geometricus* C. Koch. *Stud. Univ. "Lovanium" Fac. Sci. Leopoldville.* No. 1, 22 p.
 1957b. Les fonctions du cocon chez l'araignée *Latrodectus geometricus* C. Koch. *Ibid.* No. 2, 30 p.
 1958. La sex-ratio chez l'araignée *Latrodectus geometricus* C. Koch. *Ibid.* No. 3, 8 p.
- Bouillon, A. and R. Lekie
 1961. Cycle and rhythm in the ovulation of the spider *Latrodectus geometricus*. *Nature* 191:620-621.
- Branch, J. H.
 1943. On the life history and progressive factor in growth of *Teutana grossa* Koch. *Bull. Southern California Acad. Sci.*, 42:34-38.
- Bristowe, W. S.
 1945. (Review of "Black Widow" by Thorp and Woodson). *Entomol. Monthly Mag.* 81:xxxix-xl.
 1946. Some notes about the American black widow spider, *Latrodectus mactans* F. *Ibid.* 82:54.
- Bucherl, W.
 1969. Biology and venoms of the most important South American spiders of the genera *Phoneutria*, *Loxosceles*, *Lycosa* and *Latrodectus*. *American Zool.* 9:157-159.
- Burt, C. E.
 1935. A review of the biology and distribution of the hourglass spider. *J. Kansas Entomol. Soc.*, 8:117-130.
- Chamberlin, R. V. and W. Ivie
 1935. The black widow spider and its variations in the United States. *Bull. Univ. Utah* 25(8): Biol. Ser. 3(1):1-18.
- Cowles, R. B.
 1937. The San Diegan alligator lizard and the black widow spider. *Science* 85:99-100.
- D'Amour, F. E., F. E. Becker and W. Van Riper
 1936. The black widow spider. *Quart. Rev. Biol.* 11:123-160.
- Deevey, G. B.
 1949. The developmental history of *Latrodectus mactans* at different rates of feeding. *American Midland Nat.* 42:189-219.
- Deevey, G. B. and E. S. Deevey
 1945. A life table for the black widow. *Trans. Connecticut Acad. Sci.* 36:115-131.
- Derouet, L. and E. Dresco
 1956. Contributions à l'étude du genre *Nephila*. Sur la variabilité des mâles de *Nephila inaurata* (Walck.). *Bull. Soc. Entomol. France* 61:9-16.
- Dugès, A.
 1836. Observations sur les Aranéides. *Ann. Sci. Nat. Zool.*, ser. 2, 6:159-218.
- Emerton, J. H.
 1902. *Common Spiders of the United States*. Boston, Ginn and Co., Fig. 291.
- Exline, H. and M. H. Hatch
 1934. Note on the food of the black widow spider. *J. New York Entomol. Soc.* 42:449-450.
- Finlayson, M. H.
 1956. Arachnidism in South Africa. *In, Venoms*, A.A.A.S. Publ. no. 44, (ed. by Buckley, E. E. and N.

Porges) pp. 85-87.

Fitch, H. S.

1963. Spiders of the University of Kansas Natural History Reservation and Rockefeller Experimental Tract. Misc. Publ. Univ. Kansas Mus. Nat. Hist., No. 33:87-88.

Galiano, M. E.

1967. Ciclobiologico y desarrollo de *Loxosceles laeta* (Nicolet, 1849) Acta Zool. Lilloana 23:431-464.

Gaul, A. T.

1949. Habits and control of the black widow spider. J. Econ. Entomol. 42:700-701.

Gerhardt, U.

1928. Biologische Studien an Griechischen, Corsischen und Deutschen Spinnen. Z. Morph. Oekol. Tiere 10:621-626.

Gerschman, B. S. and R. D. Schiapelli

1943. Revisión del género *Latrodectus* Walckenaer 1805, In: R. Sampayo "Latrodectus mactans y Latrodectismo." Capítulo II (sistemática). Mus. Argentino Ciencias Nat. 23 p.

1965. El genero *Latrodectus* Walckenaer, 1805 (Araneae; Theridiidae) en la Argentina. Rev. Soc. Entomol. Argentina 27:51-59.

Gonzales, L.

1954. *Latrodectus mactans mexicanus* subsp. nov. Ann. Inst. Biol. Mexico 24:455-457.

Gowanloch, J. N. and B. F. Leeper

1935. Report on the black widow spider. Louisiana Cons. Rev. 4(7):13-21.

Hagstrum, D. W.

1968. Molting behavior of the black widow spider *Latrodectus mactans*. Ann. Entomol. Soc. America 61:591-593.

Herms, W. B., S. F. Bailey and B. MacIvor

1935. The black widow spider. Univ. California Agr. Exp. Sta. Bull. no. 591, 30 pp.

Holm, A.

1940. Studien über die Entwicklung und Entwicklungsbiologie der Spinnen. Zool. Bidrag, Uppsala 19:1-214.

Hutson, R.

1936. The black widow is rare in Michigan. Michigan Agr. Exp. Sta. Quart. Bull. 18:247.

Irving, W. G. and E. H. Hinman

1935. The blue mud-dauber as a predator of the black widow spider. Science 82:395-396.

Jellison, W. L. and C. B. Philip

1935. The biology of the black widow spider, *Latrodectus mactans*. Science 81:71-72.

Juberthie, C.

1954. Sur les cycles biologiques des Araignées. Bull. Soc. Hist. Nat. Toulouse 89:299-318.

Judd, W. W.

1965. The black widow spider (*Latrodectus variolus* Walck.) in southwestern Ontario. Ontario Field Nat. 19:24-25.

Kaston, B. J.

1937a. The distribution of black widow spiders. Science 85:74.

1937b. The black widow spider in New England. Bull. New England Mus. Nat. Hist. No. 85, 11 p.

1938. Check list of the spiders of Connecticut. Connecticut Geol. Nat. Hist. Surv. Bull. 60:175-201.

1948. The spiders of Connecticut. *Ibid.* 70:92-93.

1953. How to Know the Spiders. Dubuque, W. C. Brown Co., p. 156.

1954. Is the black widow spider invading New England? Science 119:192-193.

1968. Remarks on black widow spiders, with an account of some anomalies. Entomol. News 79:113-124.

Kaston, B. J. and G. E. Jenks

1937. Dipterous parasites of spider egg sacs. Bull. Brooklyn Entomol. Soc. 32:160-165.

Keegan, H. L.

1955. Spiders of the genus *Latrodectus*. American Midland Nat. 54:142-152.

Knowlton, G. F.

1935. The black widow spider. Utah Agr. Exp. Sta. Leaflet No. 57, 4 p.

Lamoral, B. H.

1968. On the nest and web structure of *Latrodectus* in South Africa, and some observations on body coloration of *L. geometricus*. Ann. Natal Mus. 20:1-14.

Lawson, P. B.

1933. Notes on the life history of the hourglass spider. Ann. Entomol. Soc. America 26:568-574.

Levi, H. W.

1958. Number of species of black widow spiders. Science 127:1055.

1959. The spider genus *Latrodectus*. Trans. American Micr. Soc., 78:7-43.
1966. The three species of *Latrodectus* found in Israel. J. Zool. (London) 150:427-432.
1969. Notes on American theridiid spiders. Psyche 76:68-73.
- Lucas, S. and W. Bücherl
1965. Importancia dos órgãos sexuais na sistemática de Aranhas. Mem. Inst. Butantan 32:89-94.
- Marikovskii, P. I.
1949. Contribution to the ecology of the juvenile stages of the venomous spider, *Latrodectus tredecimguttatus* R., 1790. Zool. Zhur. 26:531-538 (in Russian).
- McCrone, J. D.
1968. Biochemical differentiation of the sibling black widow spiders, *Latrodectus mactans* and *L. variolus*. Psyche 74:212-217.
- McCrone, J. D. and H. W. Levi
1964. North American widow spiders of the *Latrodectus curacaviensis* group. *Ibid.* 71:12-27.
1966. Postembryological development of spiderlings from two Peruvian *Latrodectus* populations. *Ibid.* 73:180-186.
- McKeown, K. C.
1943. Vertebrates captured by Australian spiders. Proc. Roy. Zool. Soc. New South Wales p. 17-29.
- Melchers, M.
1963. Zur Biologie und zum Verhalten von *Cupiennius salei* (Keyserling), einer amerikanischen Ctenide. Zool. Jahrb., Abt. Syst. 91:1-90.
1964. Zur Biologie der Vogelspinnen. Z. Morph. Oekol. Tiere 53:517-536.
- Miller, I. M.
1947. Amateur research on the black widow spider. Pest Control and Sanitation 2(11):22-33.
- Millot, J.
1949. Araneae. In, *Traité de Zoologie*, ed. by P. Grassé. Paris, Masson et. Cie. 6:589-743.
- Minton, S. A.
1950. Injuries by venomous animals in Indiana. Proc. Indiana Acad. Sci. 60:315-323.
- Miyashita, K.
1968. Growth and development of *Lycosa T-insignata* Boes. et Str. under different feeding conditions. App. Entomol. Zool. (Japan) 3:81-88.
- Moles, M. L.
1916. The growth and color patterns of spiders. J. Entomol. Zool. Pomona College 8(4):129-157.
- Montgomery, T. H.
1908. Sex ratio and cocooning habits of an araneid, and the genesis of the sex ratio. J. Exp. Zool. 5:429-452.
- Muller, L.
1952. La variabilité morphologique de *Coelotes atropos* Walck. Bull. Soc. Nat. Luxembourg, N. S., 45:26-35.
- Muma, M. H.
1944. The black widow spider in Maryland. Univ. Maryland Ext. Bull. No. 103, 6 p.
- O'Rourke, F. J.
1956. The toxicity of black widow spider venom. In, *Venoms*, A.A.A.S. Publ. no. 44, (ed. by Buckley, E. E. and N. Porges) p. 89-90.
- Parrott, A. W.
1946. The eyes as taxonomic characters in spiders with special reference to *Uliodon piscator* (Hogg). Rec. Canterbury Mus. 5(2):95-103.
- Petrunkevitch, A.
1911. A synonymic index-catalog of spiders of North, Central, and South America . . . etc. Bull. American Museum Nat. Hist. 29:181.
- Pickard-Cambridge, F. O.
1902. On the spiders of the genus *Latrodectus* Walckenaer. Proc. Zool. Soc. London 1:247-261.
- Pierce, W. D.
1942. Utilization of the black widow parasite, and further data on spiders and parasites. Bull. Southern California Acad. Sci. 41:14-28.
- Pinter, L. J.
1968. Species of widow spiders in Northern Argentina. Psyche 74:290-298.
- Rau, P.
1924. Some life history notes on the black widow spider (*Latrodectus mactans*). *Ibid.* 31:162-166.
1935. The wasp, *Chalybion cyaneum* Fabr., preys upon the black widow spider, *Latrodectus mactans*. Entomol. News 46:259-260.

- Reese, A. M.
1940. Variations in the markings of the black widow spider. *J. Hered.* 33:118.
- Roberts, N. L.
1941. Some notes on Australian Spiders. *Proc. Roy. Zool. Soc. New South Wales* p. 36-41.
- Robinson, M.
1947. A new food supply for *Latrodectus mactans*. *Entomol. News* 58:258.
- Roewer, C. F.
1942. (*Latrodectus*). *Katalog der Araneae. Bremen* 1:424-429.
- Semans, F. M.
1941. Black widow spider distribution in Ohio. *Ohio J. Sci.* 41:380.
- Shulov, A.
1940. On the biology of two *Latrodectus* spiders in Palestine. *Proc. Linn. Soc. London* 152:309-328.
1967. Biology and ecology of venomous animals in Israel. *Mem. Inst. Butantan.* 33:93-99.
- Shulov, A. and A. Weissman
1959. Notes on the life habits and potency of the venom of the three *Latrodectus* spider species in Israel. *Ecology* 40:515-518.
- Smithers, R. H. N.
1944. Contribution to our knowledge of the genus *Latrodectus* in South Africa. *Ann. So. African Mus.* 36:263-312.
- Szlep, R.
1965. Web-spinning process and web-structure of *Latrodectus tredecimguttatus*, *L. pallidus*, and *L. revivensis*. *Proc. Zool. Soc. London* 145:75-89.
1967. The web structure of *Latrodectus variolus* Walck. and *L. bishopi* Kaston. *Israel J. Zool.* (for 1966) 15:89-94.
- Thorn, E.
1967. Preliminary distributional list of the spiders of British Columbia. *British Columbia Prov. Mus. Ann. Rept.* (for 1966) p. 23-39.
- Wiehle, H.
1967. Steckengebliebene Emboli in den Vulven von Spinnen. *Senckenb. Biol.* 48:197-202.
- Wilson, L. F.
1967. The northern widow spider, *Latrodectus variolus*, in Michigan. *Michigan Entomol.* 1:147-153.
- Witt, P. N. and C. F. Reed
1965. Spider-web building. *Science* 149:1190-1197.

Zoology Department, San Diego State College, San Diego, California 92115

**EASTERN PACIFIC CROWN-OF-THORNS
STARFISH POPULATIONS
IN THE LOWER GULF OF CALIFORNIA**

THOMAS DANA AND ARTHUR WOLFSON

TRANSACTIONS

**OF THE SAN DIEGO
SOCIETY OF
NATURAL HISTORY**

VOL. 16, NO. 4

24 NOVEMBER 1970

THIS PAGE IS LOCKED TO FREE MEMBERS
Purchase full membership to immediately unlock this page

DELVE INTO FANTASY, MAGIC, MYTHOLOGY & FOLKLORE

Forgotten Books'
Full Membership gives
access to 797,885 ancient
and modern, fiction and
non-fiction books.

Continue

*Fair usage policy applies

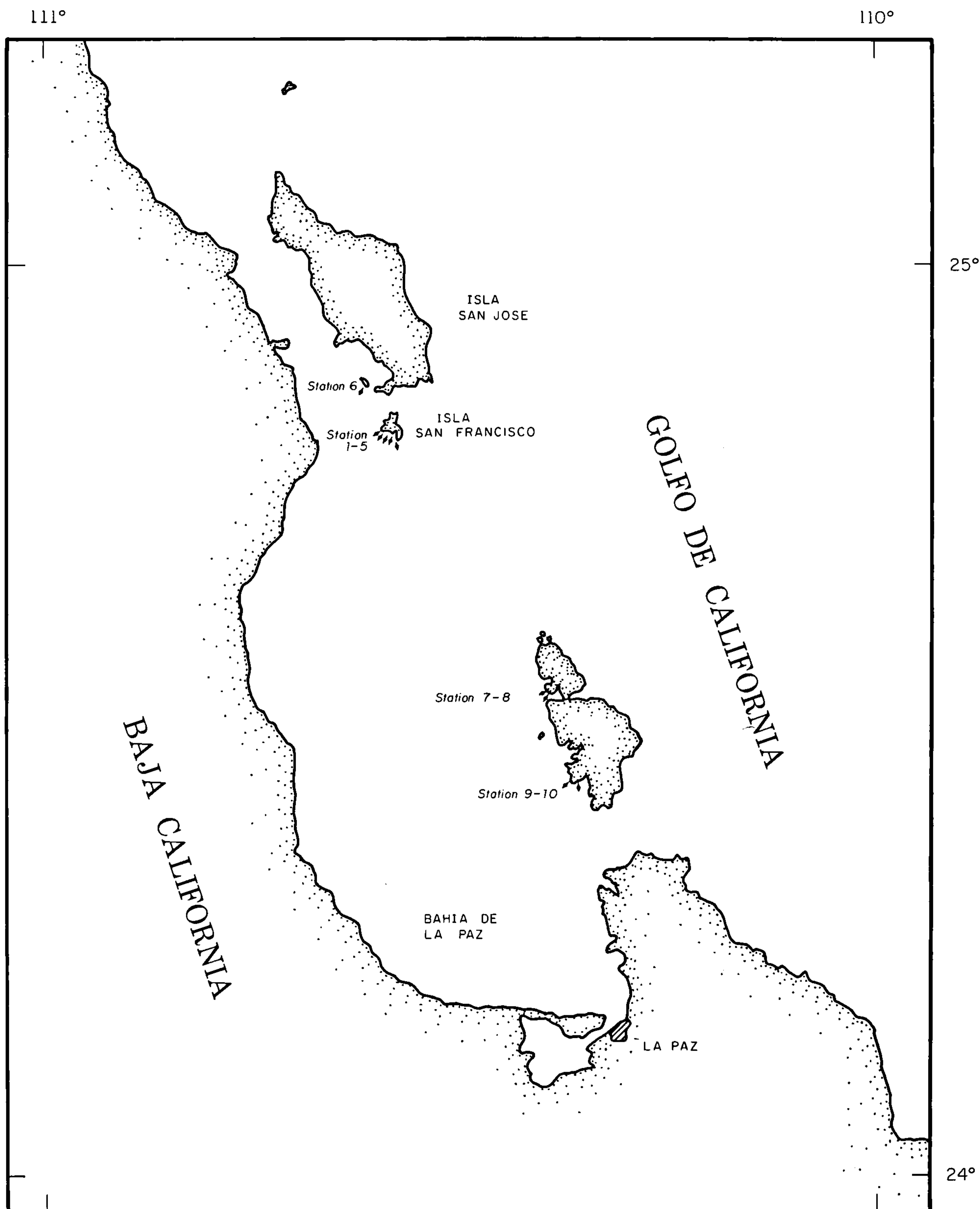

Figure 1. Map of study area in lower Gulf of California, Mexico showing station locations.

Isla San Francisco ($24^{\circ}55'N$, $110^{\circ}35'W$) on 23 and 25 April, Isla San Jose ($24^{\circ}55'N$, $110^{\circ}35'W$) on 24 April, and Isla del Espiritu Santo ($24^{\circ}35'N$, $110^{\circ}25'W$) on 26, 27, and 28 April, 1970, to investigate various aspects of the ecology of those populations (Figure 1).

METHODS

Area, depth, and per cent coral coverage of all surveyed areas were estimated. Usually

in making surveys two divers were towed at slow speeds (1 to 2 knots), one on each side of a 12' skiff. In early stages of the survey all *A. ellisii* located were investigated for active feeding; later only occasional individuals were checked. Frequently, when visibility and the width of suitable substrate prohibited a thorough survey by towing, free or SCUBA diving was employed to more completely cover the area. At several stations both day and night observations were made. Only diving was utilized for night surveys, during which special emphasis was placed on locating juvenile *A. ellisii* (none were found). Specimens were collected from selected areas and individuals were kept in a large opaque aquarium on board ship. A variety of living corals were presented to these specimens. All the *Acanthaster* collected were measured (disk diameter) and gonad samples taken.

RESULTS

Isla San Francisco. — The area adjoining nearly the entire western half of the island was surveyed. Detailed observations were, however, limited to the southwestern sector.

Station 1 was the submerged portion of a spit composed of small boulders (<0.5m in diameter) at the southern end of a small sandy embayment. The area investigated measured some 120×10m, with depths ranging from 0.5 to 2m. All observations were made while snorkeling. Coral coverage was 2 to 3%, consisting of small patches of *Porites* (3-6 cm in diameter) and scattered individual heads of *Pocillopora*. Seven *A. ellisii*, all in the open, were located; most were feeding on small *Porites* patches during the day. There was evidence of occasional feeding on *Pocillopora*, but none of these coral heads were completely eaten. (Density of *A. ellisii*: 0.006/m² or 1/171m².)

Station 2 was located along a rocky shoreline across the sandy embayment from Station 1 and included the point at the northwestern end of the bay. The substrate consisted of large boulders (>1m in diameter) that had tumbled down onto a flat sandy bottom. These boulders were almost completely covered with algae. The area surveyed stretched for about 315m along the shore and varied in width from 8m on the inner end to 15m at the northwest point. Depth of the water to sand bottom gradually increased from 5 to 15m at the point. Day observations were made towing, free diving, and with SCUBA. Coral coverage was estimated to be less than 1%, except at the point where it was between 2 and 3%. Small encrusting patches of *Porites* and small heads of *Pocillopora* were present. Several larger heads of *Pocillopora* and patches of *Porites* (>30 cm in diameter) were found in shallow water at the point. A total of 27 *A. ellisii* (including 7 taken by Faulkner on 18 April) were scattered throughout the area. Nearly all were in water between 1 and 5m deep and were feeding on patches of *Porites*. A single individual which was not feeding was found in 12m of water at the northwest point. (Density of *A. ellisii*: 0.009/m² or 1/117m².)

Station 3 began on the north side of the point where Station 2 terminated and continued for some 200m into an adjacent cove. The substrate was similar to that of Station 2 except the boulders were smaller and less algal covered. The rocky area was 5 to 8m wide, ending on a smooth sand bottom in 3 to 4m of water. Coral coverage was estimated to be less than 1%. Four *Acanthaster* were seen but were not checked for feeding. (Density of *A. ellisii*: 0.003/m² or 1/400m².)

Station 4 was located on the north side of a small cove opposite Station 3. The substrate along the inner 75m of the cove was a grey, vesicular basalt dipping seaward gently for about 18m to a depth of 3 to 4m, and then more sharply to a smooth sand bottom at a depth of 9m. This area was surveyed by towing and free diving during the day. The bottom over the remaining 310m length of the area consisted of large boulders and was surveyed by day towing and a SCUBA dive at night. The entire station was densely covered

with algae. Coral cover was between 1 and 2% and consisted of small patches of *Porites* and occasional small heads of *Pocillopora*. A total of 24 *Acanthaster* (including 12 collected by Faulkner on 19 April) were found at this station. Most individuals observed during the day were feeding in the open on small patches of *Porites*. Identical behavior was observed during the night dive with the additional observations of one completely cleaned colony of *Pocillopora* and a single *Acanthaster* feeding on a gorgonian (*Pacifigorgia* sp.) in a crevice. (Density of *A. ellisii*: 0.006/m² or 1/160m².)

Station 5, located along the southern side of the cove adjacent to Station 4, comprised an area of 300 x 10m. The bottom was an algal-covered sloping rock outcrop with a few boulders scattered at its seaward extremity. Sand replaced the rocky substrate in about 3m of water. Observations were made by towing and free diving in daylight. Coral coverage was 8 to 10%, consisting principally of encrusting to submassive patches of *Porites*, a few heads of *Pocillopora*, and an occasional patch of *Pavona*. (Density of *A. ellisii*: 0.002/m² or 1/600m².)

Isla San Jose. — A single station (Station 6) was made at this island — around a linear rock outcrop well out into the mouth of the large bay on the southwestern extremity of the island. The substrate consisted of large algal covered boulders, and water depth to sand bottom ranged from 6m at the northern end of the outcrop to 14m at the southern end. The area surveyed was about 375m long and 10 to 12m wide. Corals present were *Porites*, *Pocillopora*, and *Tubastrea*, and cover for most of the area was about 1%, increasing slightly at the southern tip where a strong current prevailed. Observations were made towing and with SCUBA. During the day 5 *Acanthaster* were found scattered along the western side of the outcrop, all in less than 4m of water. Three were in the open, fully exposed but not feeding, another was feeding on a gorgonian (*Pacifigorgia* sp.), and one had its stomach everted over a clump of *Padina* sp. (a lightly calcareous brown alga). All of these specimens were collected and no additional individuals were located that night. (Density of *A. ellisii*: 0.001/m² or 1/750m².)

Isla del Espiritu Santo. — Two stations were occupied in the northwestern sector of the mouth of an embayment on the western side of the isthmus. The first, Station 7, was around a small rock outcrop a short distance out into the bay. The surveyed area was approximately 500m². All observations were made snorkeling during the day. Algal cover was much sparser than at previous stations and coral coverage was between 4 and 5%. Small patches of *Porites* were present, a single clump of *Psammocora* (*Stephanaria*) was noted, and a number of colonies of *Pocillopora* (up to 0.75m in diameter) were scattered about. Eight *Acanthaster* were observed in 1 to 3m of water. (Faulkner also collected one individual from this locality on 15 April.) Of the 8, 7 were feeding on tiny patches of *Porites*, and one was under a large head of *Pocillopora* — a small portion of which had been eaten. (Density of *A. ellisii*: 0.016/m² or 1/63m².)

A small point opposite Station 7 was selected for Station 8. An estimated 1100m of rock outcrops and boulders were investigated by free diving. Algal and coral coverage, as well as the kinds of corals, were similar to Station 7. Of the 8 *Acanthaster* seen during the day, 6 were feeding on *Porites* and one on *Psammocora* (*Stephanaria*). (Density of *A. ellisii*: 0.007/m² or 1/138m².)

Two stations were made at the northwestern extremity of Bahia de San Gabriel, located in the southwestern sector of Isla del Espiritu Santo. The first, Station 9, was located just outside and to the north of the bay at Punta Prieta and covered approximately 600m² of rock ledges and boulders in water less than 5m deep. Coral coverage was between 3 and 4%, principally *Pocillopora*, and under ledges, *Tubastrea*. No *Acanthaster* were found during the day or night.

THIS PAGE IS LOCKED TO FREE MEMBERS
Purchase full membership to immediately unlock this page

FORGOTTEN BOOKS

FULL

MEMBERSHIP

797,885 Books!

All you can read

for only

\$8.99/month

Continue

*Fair usage policy applies



larger average *Acanthaster* population levels (Chesher, 1970; Weber, 1970).

Ninety *Acanthaster* (including the 20 taken by Faulkner) were located within the 20,250m² surveyed in detail. The average density obtained, 0.0045/m² or about 1/225m², exceeds several of Chesher's definitions of normal population densities for *A. planci*: 2 or 3/1000m², 4 or 5/km of reef, 1/hour of search, and 20/20 minutes of search but usually no more than 8 (Chesher, 1969, 1970). For several stations densities approached, and at one station exceeded, the density reported for the infestation of Double Reef, Guam (886 animals on 90,000m² of reef, Chesher, 1969). The effect of the starfish on coral formations in the lower Gulf of California is certainly problematical, especially considering the general lack of reef development and sparse distribution of corals in that area (Squires, 1959). Excluding the 2 stations from Bahia de San Gabriel, coral coverage, in terms of projected images of individual colonies, averaged about 3% over 18,150m². There are then approximately 6.1m² of coral standing crop available for each *Acanthaster*, although the actual feeding surface is certainly greater. Using a consumption rate of twice the area of the disk per day (Chesher, 1969, for *A. planci*), approximately 5.3m² of coral would be consumed by an average size *A. ellisii* in a year's time. Such a feeding rate would require a replacement rate of coral standing crop — in terms of areal coverage — of 87% annually. However, this feeding rate, considering the effects of temperature differences on metabolic rate (Kinne, 1963), is probably an overestimate (surface temperatures in the lower Gulf of California range from 17 to 31°C with an annual mean of 24.7°C, while the tropical western Pacific remains nearly uniform at 28°C; see Roden, 1964).

The relationship between increase in weight and increase in area of the projected image of a coral colony is difficult to estimate and depends in a complex manner on such factors as growth form, degree and mode of branching, and skeletal density. Nevertheless, growth data giving annual increments of increase as per cent gain in weight does not seem an unreasonable means of approximating a coral replacement rate. In Hawaii, Edmondson (1929) found an average annual weight increase for a number of colonies of various sizes of two species of *Porites* to be 60.7% and 90.4% and of three species of *Pocillopora* to be 148.0%, 137.5%, and 103.9%. Since the Hawaiian Islands are on the border of the tropics, coral growth data from there seem appropriate for comparison, even though Hawaiian growth rates certainly exceed those in the lower Gulf of California. Despite the complications, it appears that under present conditions coral growth alone should be sufficient to provide enough tissue to satisfy the energetic requirements of current population levels of *A. ellisii*.

The gonad analysis indicates that in the Gulf of California *Acanthaster* has at least a protracted, if not continuous, spawning season. This does not agree with the report from Green Island (about 16°S) on the Great Barrier Reef of a highly synchronous breeding season in December and January for *A. planci* (Endean, 1969), nor with the contention of Chesher (1969) of a breeding season for *A. planci* at Guam (about 16°N) during November and December. Our data, however, agree with analyses by Pearse on specimens from Guadalcanal, Guam, Ifaluk, and Wolei (Eldredge, 1970), and with Mortensen's observation (1931) from off Java (about 6°S) that, for *A. planci*, the sexual products are not shed all at once but in portions at different times. Furthermore, continual influx of young, or recruitment extending over many months, could account for the lack of modes representing year classes in the size-frequency distribution of the populations of *A. ellisii* observed.

Since no growth rate data are available for *A. ellisii*, age structure of the populations cannot be inferred from their size distribution. However, one important point about the shape of the size-frequency curve, as it relates to population increases, should be made: the peak at intermediate sizes (see Figure 2) does not necessarily indicate an unusually large

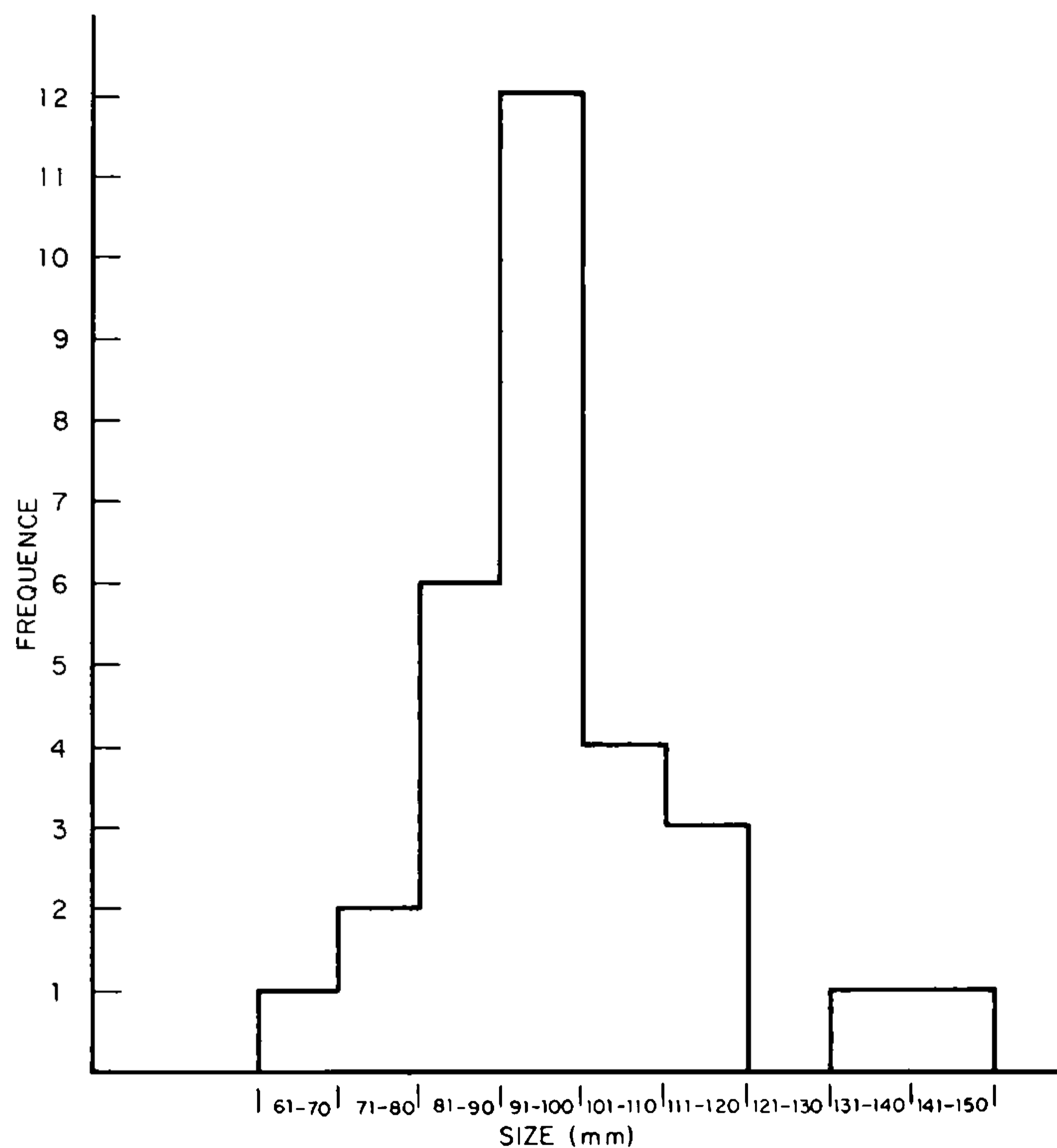

Figure 2. Size frequency histogram based on 30 specimens. Range, 62-142 mm; mean, 97.9 mm (median, 95.5 mm).

recent influx of young. Several combinations of survivorship curves coupled with non-linear growth could give size-frequency distribution curves of the shape observed even when annual recruitment is relatively constant over a period of several years. Probably the populations observed contain individuals in several year classes, and any contention for a recent population increase would be highly speculative.

Lacking adequate knowledge of recruitment, settling requirements, survivorship, spawning periods and behavior, growth rates, rates of mortality from various sources, and longevity of both corals and *Acanthaster*, as well as information concerning past population levels and fluctuations, we consider drawing any conclusions as to the consequences of present levels of predation on corals in the lower Gulf of California by *A. ellisii* tenuous at best. However, the feeding pressure exerted by *A. ellisii*, when coupled with suboptimal temperatures for corals resulting in relatively slow growth rates, an observed abundance of boring organisms, and paucity of coralline algae to serve as a binding agent, may contribute significantly to the almost total absence of reef formation in the Gulf of California.

ACKNOWLEDGMENTS

We would like to thank Dr. D. John Faulkner for bringing the situation in the Gulf to our attention, Garth Nicholson for help with the field work, Dr. John S. Pearse for analysis of the gonad samples, Dr. William A. Newman for encouragement and critical reading of the manuscript, and the Foundation for Ocean Research for travel and ship time.

LITERATURE CITED

Barnes, J. H.

1966. The crown of thorns starfish as a destroyer of coral. *Australian Mus. Mag.* 15: 257-261.

Bayer, F. M.

1951. A revision of the nomenclature of the Gorgoniidae (Coelenterata: Octocorallia), with an illustrated key to the genera. *Wash. Acad. Sci.* 41: 91-102.

Caso, M. E.

1962. Estudios sobre Asteridos de Mexico: Observaciones sobre especies Pacificos del genero *Acanthaster* y descripcion de una subespecie nueva, *Acanthaster ellisii pseudoplanci*. Ann. Inst. Biol. Univ. Mexico 32: 313-331.

Chesher, R. H.

1969. Destruction of Pacific corals by the sea star *Acanthaster planci*. Science. 165: 280-283.
1970. *Acanthaster planci*: Impact on Pacific coral reefs. U.S. Dept. Interior. Publ. 187631.

Dana, T. F.

1970. *Acanthaster*: a rarity in the past? Sciences. 169:894.

Edmondson, C. H.

1929. Growth of Hawaiian corals. Bernice P. Bishop Mus., Bull. 58: 1-38.

Eldredge, L. G.

1970. *Acanthaster* Newsletter, no. 2, from the Marine Laboratory, Univ. of Guam, Agana, Guam.

Endean, R.

1969. Report on investigations made into aspects of the current *Acanthaster planci* (Crown-of-thorns) infestations of certain reefs of the Great Barrier Reef. Brisbane, Queensland Dept. of Primary Industries, Fisheries Branch.

Goreau, T. F.

1964. On the predation of coral by the spiny starfish *Acanthaster planci* (L.) in the southern Red Sea. Israel South Red Sea Expedition, 1962. Rept. no. 2, Bull. Sea Fish. Res. Sta., Haifa 35: 23-26.

Kinne, O.

1963. The effects of temperature and salinity on marine and brackish water animals. Oceanogr. Mar. Biol. Ann. Rev. 1: 301-340.

Mortensen, Th.

1931. Contributions to the study of the development and larval forms of echinoderms: I-II. D. Kgl. Danske Vidensk. Selsk. Skrifter, naturvidensk. og mathem. Afd., 9 Raekke, IV 1: 1-39.

Newman, W. A.

1970. *Acanthaster*: a disaster? Science 167: 1274-1275.

Roden, G. I.

1964. Oceanographic aspects of the Gulf of California. In Marine Geology of the Gulf of California, A Symposium. Memoir 3. Amer. Assoc. Petrol. Geol. Edited by T. H. van Andel and G. G. Shor, Jr.

Squires, D. F.

1959. Results of the Puritan-American Museum of Natural History Expedition to Western Mexico: Corals and coral reefs in the Gulf of California. Bull. Amer. Mus. Nat. Hist. 118: 371-431.

Steinbeck, J., and E. F. Ricketts

1941. The Sea of Cortez, a Leisurely Journal of Travel and Research, with a Scientific Appendix Comprising Materials for a Source Book on the Marine Animals of the Panamic Faunal Province. New York, Viking Press.

Weber, J. N.

1969. Disaster at Green Island — other Pacific islands may share its fate. Earth and Mineral Sci. 38: 37-41.

Weber, J. N., and P. M. J. Woodhead

1970. Ecological studies of the coral predator *Acanthaster planci* in the South Pacific. Marine Biology 6: 12-17.

THIS PAGE IS LOCKED TO FREE MEMBERS
Purchase full membership to immediately unlock this page

DELVE INTO FANTASY, MAGIC, MYTHOLOGY & FOLKLORE

Forgotten Books'
Full Membership gives
access to 797,885 ancient
and modern, fiction and
non-fiction books.

Continue

*Fair usage policy applies

EVOLUTION OF *PEROMYSCUS* ON NORTHERN ISLANDS IN THE GULF OF CALIFORNIA, MEXICO.

TIMOTHY E. LAWLOR

ABSTRACT.—Mice of the genus *Peromyscus* on northern islands of the Gulf of California and adjacent mainland areas were examined to trace the divergence of populations there. A total of 27 qualitative characters of the osteology, pelage, phallic morphology, soft anatomy, serology, and karyology was examined in detail. Morphometric characters and dental patterns also were studied, and matings of pertinent forms were attempted with limited success.

The island and mainland forms were treated numerically according to the above qualitative characters, as follows: (1) Two Prim Networks were computed, utilizing different combinations of characters. Each indicated that *P. stephani* (Isla San Esteban) is closely related to *P. boylei*, and that those two species and *P. crinitus* are only distantly related to the remainder of the island and mainland forms. (2) A dendrogram (Wagner Diagram) was computed for the latter, using the quantitative phyletic method. *P. eremicus* was considered ancestral on morphologic and zoogeographic grounds. *P. guardia* (Islas Angel de la Guarda, Granito, and Mejía) is the most divergent of the *eremicus*-like forms and cladistically is closest to *P. merriami*. *P. interparietalis* (Islas San Lorenzo Sur, San Lorenzo Norte, and Salsipuedes) also is relatively far removed from the hypothetical *eremicus*-like ancestor. Populations from the Baja Californian and Sonoran mainlands and Isla Tiburon (*P. eremicus*), and Isla Turner (*P. collatus*), are closely related and should be considered conspecific. On zoogeographic grounds, the populations on western Gulf islands (*guardia*, *interparietalis*) probably are derived from a Baja Californian *eremicus*-like progenitor, whereas eastern island forms (*collatus*, *eremicus tiburonensis*) and *stephani* probably are derived from Sonoran *eremicus*-like and *boylei*-like forms, respectively. Evidence from morphology, amount of gene flow between islands and between islands and the mainland, and time of formation of the islands, suggests that the time interval since initial formation of the islands has been the principal factor affecting divergence of the island populations.

Trends in the evolution of certain characters among Gulf *Peromyscus* suggest that complex features may result from simple conditions in the phallus and dentition, and that acrocentric chromosomes derive from a bi-armed condition. The data suggest that the subgenus *Haplomyomys*, which consists of *eremicus*-like species, contains primitive members of the genus.

RESUMEN.—Se estudiaron los ratones del género *Peromyscus* en las islas septentrionales del Golfo de California y zonas adyacentes del continente, con objeto de determinar las divergencias que presentan sus poblaciones. Se examinaron con todo detalle un total de 27 caracteres morfológicos, relacionados con la osteología, pelaje, órganos sexuales externos y otros caracteres anatómicos, serológicos y citológicos. También se analizaron los caracteres morfométricos y la dentición, intentándose además cruces entre las formas pertinentes, obteniendo éxitos muy limitados.

Las formas encontradas en las islas del Golfo de California y en el continente se analizaron numericamente en cuanto a los caracteres morfológicos arriba mencionados, en la forma siguiente: 1) Se efectuaron dos "Prim Networks," utilizando diferentes combinaciones de caracteres. En cada caso resultó que *P. stephani* (isla de San Esteban) aparecía como pariente próximo de *P. boylei*, y estas dos especies con *P. crinitus* resultan parientes lejanos de las formas restantes que habitan estas islas y el continente. 2) El diagrama dendítico (diagrama de Wagner) se computó para *P. crinitus*, utilizando el método filogenético cuantitativo. *P. eremicus* aparece así como una especie ancestral, basándonos en la morfología y la zoogeografía. *P. guardia* (islas Angel de la Guarda, Granito y Mejía) es la especie que diverge más de las formas del tipo *eremicus*, y la más próxima en la escala a *P. merriami*. *Peromyscus interparietalis* (Islas de San Lorenzo Sur, San Lorenzo Norte y Salsipuedes) aparece como una segregación lejana del ascendiente hipotético tipo *eremicus*. Las poblaciones de *P. eremicus* de las zonas continentales de Baja California, Sonora y de la isla Tiburon, y las de *P. collatus* de la isla Turner aparecen muy

relacionadas entre si, por lo que podrían considerarse co-específicas. Bajo el punto de vista zoogeográfico, las poblaciones de las islas occidentales del Golfo (*guardia*, *interparietalis*) derivan probablemente de un progenitor tipo *eremicus* de Baja California; mientras que es posible que las formas de las islas orientales (*collatus*, *eremicus*, *tiburonensis*) y *stephani* procedan respectivamente del tipo *eremicus* y del tipo *boylei*. Las características morfológicas evidencian un flujo importante de genes de unas islas a otras y entre éstas y tierra firme durante el período de formación de dichas islas; lo cual sugiere que el lapso de tiempo transcurrido desde que se inició la formación de esas islas constituye el factor principal responsable de la divergencia encontrada en las poblaciones insulares.

La tendencia o curso en la evolución de ciertos caracteres en los *Peromyscus* del Golfo sugiere que estructuras complejas pueden resultar simplemente de las condiciones de los órganos sexuales externos y la dentición, y que los cromosomas acrocéntricos derivan de una condición bifurcada. Los datos obtenidos indican que el subgénero *Haplomylomys*, que incluye las especies tipo *eremicus*, contiene los miembros primitivos del género.

The ecologic and geographic characteristics of islands make them particularly suited for studies concerning differentiation and adaptation in natural populations. In general, climatic stability, decreased ecologic diversity, and increased isolation distinguish islands from mainland areas. In the sense of Preston (1962), the plant and animal populations of an island form a complete ("canonical") system as a result of these peculiarities, while mainland populations represent only a "sample" of a more widely distributed and more diverse biota. Thus, effects of isolation are more pronounced on islands than on continental areas.

In addition, islands presumably are subject to colonization by organisms undergoing primary radiation on continental areas. This seems like a reasonable assumption, although the reverse situation undoubtedly occurs to a lesser degree. Consequently, insular populations may constitute unique control groups in which to examine patterns of evolution and divergence of particular groups of organisms.

Mice of the genus *Peromyscus* are widely distributed in North America in insular and mainland situations. They are nearly ubiquitous on island and mainland areas in and surrounding the Gulf of California. No less than 18 species of two subgenera are recognized there, of which ten are island endemics. It appears that at least five of the seven non-endemic species were important for radiation of the group onto the islands of the Gulf. The following account is an assessment of the morphologic, serologic, and karyologic divergence of the island populations of *Peromyscus* relative to one another and to those on the mainland of Baja California to the west and Sonora, Mexico, to the east.

The geographic area of study consists of the northern group of Gulf islands (Figs. 1 and 2). These islands form an irregular chain from one side of the Gulf to the other, thus affording several possible access routes to and from the mainland. In addition, the chain is separable into deep- and shallow-water islands. The latter group consists of islands (Turner, Tiburon) occupying waters within the 110 meter depth contour, the level to which the sea is thought to have been lowered by eustatic changes during the Pleistocene, whereas the former group (San Esteban, Salsipuedes, the Lorenzos, and Angel de la Guarda and nearby islands) consists of islands that attained their present configuration as long ago as Pliocene (Anderson, 1950). Thus, certain of the islands are chronologically much younger than others by virtue of their relatively recent separation from the mainland.

One would expect a greater degree of morphological and genetic differentiation in peromyscines inhabiting distant and deep-water islands as a result of more effective isolation than in those mice on islands in close proximity to the mainland and in shallow water. The latter islands could be subjected to repeated invasions by mice from mainland populations, resulting in suppression of morphological or genetic differences that might

THIS PAGE IS LOCKED TO FREE MEMBERS
Purchase full membership to immediately unlock this page

FORGOTTEN BOOKS

FULL MEMBERSHIP

797,885 Books!
All you can read
for only
\$8.99/month

Continue

*Fair usage policy applies





Figure 2. Map of the northern islands of the Gulf of California, Mexico, and adjacent mainland areas enlarged from the insert in Fig. 1.

thoroughly documented. Currently populations of five species are recognized, all of which are included in the subgenus *Haplomyloms* and are considered closely related to *P. eremicus*:

P. eremicus tiburonensis (Mearns, 1897); Isla Tiburon

P. collatus Burt, 1932; Isla Turner (= I. Datil)

P. stephani Townsend, 1912; Isla San Esteban

P. guardia guardia Townsend, 1912; Isla Angel de la Guarda

P. guardia mejiae Burt, 1932; Isla Mejia

P. guardia harbisoni Banks, 1967; Isla Granito

P. interparietalis interparietalis Burt, 1932; Isla San Lorenzo Sur

P. interparietalis lorenzo Banks, 1967; Isla San Lorenzo Norte

P. interparietalis ryckmani Banks, 1967; Isla Salsipuedes

Taxonomically these forms have remained virtually unchanged since their description, except that *tiburonensis* is now considered a subspecies of *eremicus* (Osgood 1909; cf. Mearns, 1897), and *interparietalis* is considered specifically distinct from *guardia* (Banks, 1967; cf. Burt, 1932). Hooper and Musser (1964b) have suggested, on the basis of phallic morphology, that *stephani* may be closely related to species of the subgenus *Peromyscus*.

MATERIALS AND METHODS

Specimens examined in this study were collected during trips to the Gulf of California and surrounding areas in the summers of 1967 and 1968, and in January, 1969, or were borrowed from the following institutions: California Academy of Sciences (CAS); Dickey Collection, University of California, Los Angeles (UCLA); San Diego Natural History Museum (SD); Department of Zoology, University of Arizona (UA); Museum of

Vertebrate Zoology, University of California, Berkeley (UC); Museum of Natural History, University of Kansas (KU); Museum of Zoology, University of Michigan (UMMZ); and the United States National Museum (USNM). Both live and preserved examples of each of the island populations were obtained.

Except for analysis of variation in dental patterns, only adult wild-caught mice were treated for purposes of studying morphologic, serologic, and karyologic features. All age groups were examined in the former, although specimens with excessive tooth wear were omitted. Adult status was determined according to the methods of Lawlor (1964) and Hoffmeister (1951). Briefly, an animal was considered an adult if there was at least moderate wear on the lingual cusps of M^1 and M^2 (the M^3 generally is well worn at this age), and if the specimen was in advanced ("adult") pelage. Specimens examined for serologic and karyologic properties were considered adult after retention in the laboratory for at least two months.

In osteological considerations I dealt with quantitative and qualitative measures of cranial and other skeletal features. Measurements, in millimeters, were taken with dial calipers. Post-cranial features were examined from whole skeletons except that the number of caudal vertebrae was determined from X-rays. The latter technique provides an accurate means of counting vertebrae and avoids potential error in vertebral counts of whole skeletons owing to vagaries of preparation. External characters include field-taken body measurements and pelage features.

Dental patterns were examined according to a modified scheme of the procedure specified by Hooper (1957). Lophs and styles were considered present only if they comprised a prominent element of an enamel valley. Even so, considerable variation accrues in the development and appearance of these structures. Variation is particularly evident in the shape and placement of styles, but no rigorous attempt was made to determine homologies.

Phalli of freshly killed mice were extracted and fixed in 10% formalin. After everting the prepuce over the proximal portion of the glans, the following procedure was used for clearing and staining:

2% KOH solution	ca. 60 minutes
Alizaren red stain (in 2% KOH)	1-2 hours
Distilled water wash	1 minute
Solution of 2 pts. HOH, 1 pt. glycerin	ca. 24 hours
Solution of 1 pt. HOH, 2 pts. glycerin	ca. 24 hours
Glycerin	permanent storage

The procedure for dried specimens differed slightly. Good results were obtained by shortening the clearing and staining times by about one-half. This reduces the chances for sloughing of the epithelial layer, a common occurrence if the glans was kept in KOH solutions for long periods. The remaining steps were the same.

Karyotypes were examined by means of a bone marrow technique (Patton, 1967). An average of 10 metaphase cells was counted to determine the diploid number of each individual. The fundamental number ("Nombre Fundamental" of Matthey, 1951) was determined as the total number of autosomal arms (excluding the sex chromosomes). The system for describing the chromosomes (Patton, 1967) was as follows:

<i>Chromosome type</i>	<i>Arm ratio</i>
Metacentric	Less than 1:1.1
Submetacentric	1:1.1 to 1:1.9
Subtelocentric	1:2 or greater
Acrocentric (telocentric)	One arm only

Electrophoretic analyses were made according to the modified method of Smithies (1955) used by Brown and Welser (1968).

The taxonomic designations that are applied below to island and mainland populations concerning character diagnoses, and the discussion of phylogenetic and zoogeographic relationships that follows, correspond to the currently held taxonomy of those forms (see above). They are used only to facilitate interpretation by the reader; they do not reflect any taxonomic evaluation made prior to construction of the phylogeny and taxonomic conclusions.

Statistics and construction of the dendrogram and phenograms were calculated by use of an IBM 360/67 computer at the University of Michigan Computation Center.

MORPHOLOGIC VARIATION MORPHOMETRIC CHARACTERS

A total of 20 external and cranial dimensions was examined. Six of these (total length, length of tail, greatest length of skull, zygomatic breadth, length of rostrum, and length of maxillary toothrow) are presented in Figs. 3-5. The remainder are either relatively invariable or exhibit similar geographic changes as the ones treated in detail here.

Mice of the *guardia* islands (Angel de la Guarda, Mejía, and Granito) show no consistent trends of inter-island variation in size, although significant differences ($P < .05$) are evident in certain dimensions. However, *interparietalis* (Isla Salsipuedes, San Lorenzo Norte, and San Lorenzo Sur) exhibits a trend of increasing size in nearly all dimensions from Salsipuedes in the north to San Lorenzo Sur in the south. An exception is zygomatic breadth, and the relative constancy of this dimension together with the variation for greatest length of skull gives *interparietalis* from Salsipuedes a shorter, broader-headed appearance than its southern island counterparts. *P. stephani* (Isla San Esteban) differs from other island forms in having cranial dimensions that usually average larger.

In general, forms from Islas Turner (*collatus*) and Tiburon (*eremicus*) were similar to mainland *eremicus* on the basis of morphometric characters. Other mainland populations of *eremicus* in the Gulf area do not differ importantly from the two samples given in Figs. 3-5 (for example, see Lawlor, in press).

The large differences in certain dimensions evident between insular populations of the same species (e. g., in *interparietalis* and *guardia*) suggest that isolation of these mice on islands has resulted in the retention of morphometric differences that generally are eliminated by higher rates of gene flow in continental populations. For example, differences of significant proportions usually are not evident in morphometric data for mainland populations of *eremicus* (*Ibid.*).

DENTAL PATTERNS

Dental topography in all of the island forms is relatively simple. The enamel valleys between major cusps generally are unobstructed except for styles. The most common accessory tooth structures are ectostylids on the lower molars (M_1 and M_2) and mesostyles on the uppers (Figs. 6, 7; Table 1); the latter are more variable in frequency and are found uncommonly on the second molars. Mesolophids occur at high frequency in the M^1 only in mice from Islas Granito and San Esteban, whereas entolophids, mesolophids, and ectolophids were not observed in any specimens. A "pseudomesolophid" (Herskovitz, 1962) was observed in several specimens of *interparietalis* on the lower first molar (two specimens [5.6%] from Isla San Lorenzo Norte and four [11.7%] from Isla San Lorenzo Sur). The mesoloph and mesostyle are rarely fused. This condition was observed on the M^1 in only two (7.1%) specimens of *stephani* and one (4.8%) of *eremicus* from Bahía de los

THIS PAGE IS LOCKED TO FREE MEMBERS
Purchase full membership to immediately unlock this page

DELVE INTO FANTASY, MAGIC, MYTHOLOGY & FOLKLORE

Forgotten Books'
Full Membership gives
access to 797,885 ancient
and modern, fiction and
non-fiction books.

Continue

*Fair usage policy applies

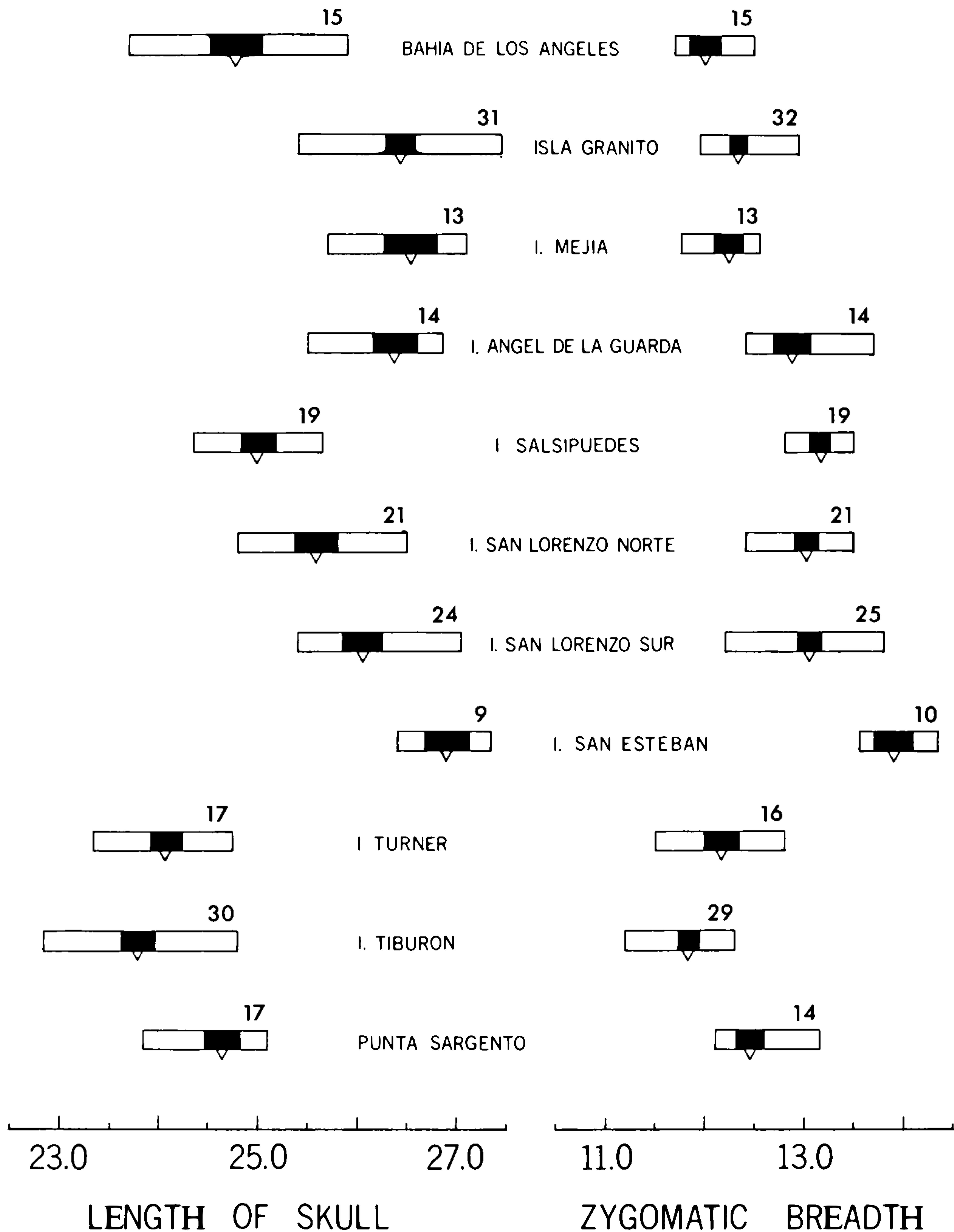

Figure 4. Geographic variation of two cranial dimensions of *Peromyscus* on northern island and mainland areas in and adjacent to the Gulf of California, Mexico. For explanation of plots see Fig. 3.

three populations of *guardia* (Figs. 6 and 7, Table 1). Similar variation was noted in several species of *Peromyscus* by Hooper (1957). His results for *eremicus* correspond closely to those presented for populations of that species here.

QUALITATIVE CHARACTERS

Osteology. — Variation in osteological characters among *Peromyscus* commonly is subtle, and distinct character differences often are difficult to detect in closely related species. The skulls of six island and mainland examples studied here are illustrated in Fig. 8. Eight cranial features of taxonomic importance were discernible in the island and mainland forms. Many of these features were observed by Banks (1967). The characters and their character states are as follows:

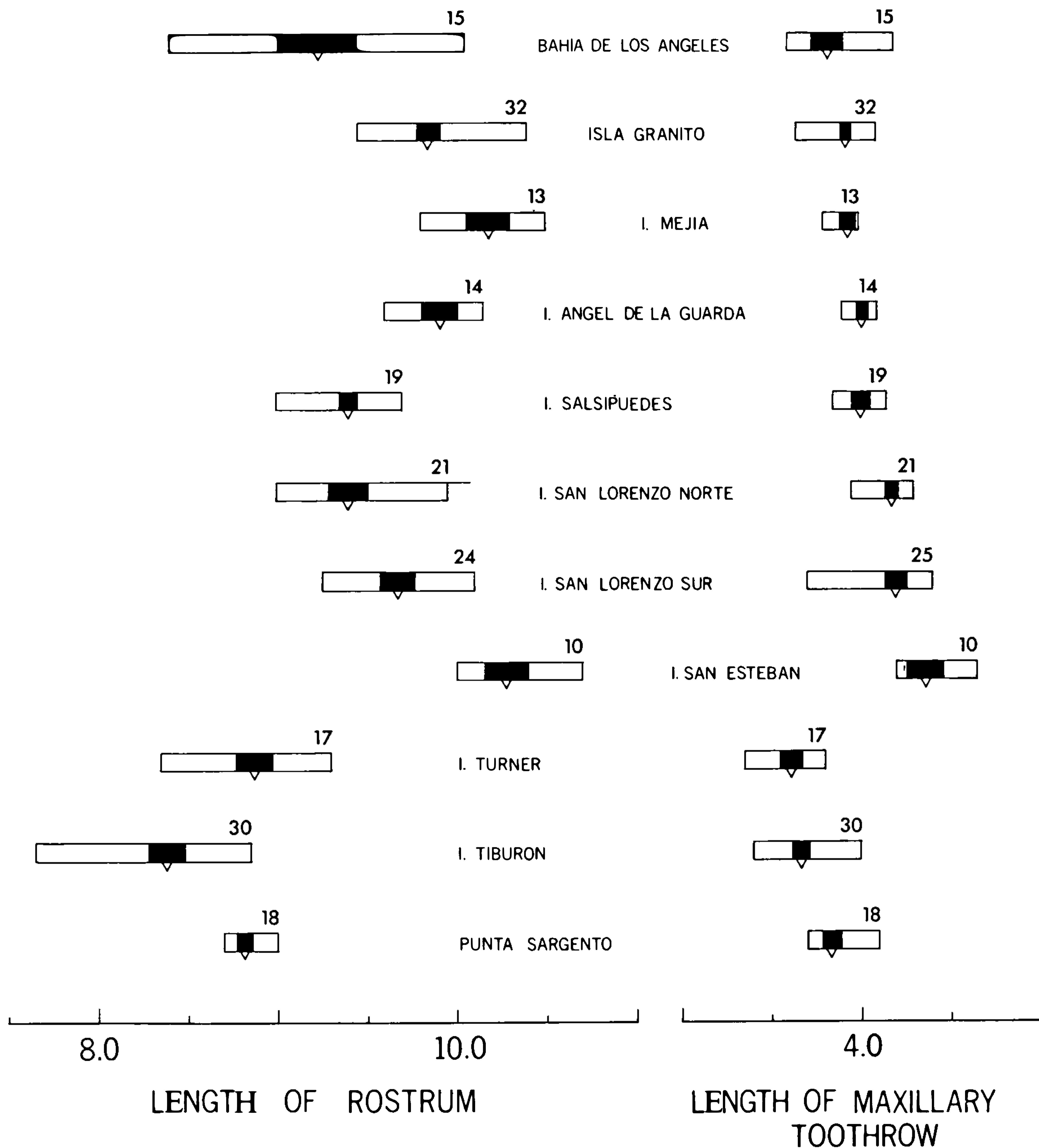

Figure 5. Geographic variation of two cranial dimensions of *Peromyscus* on northern island and mainland areas in and adjacent to the Gulf of California, Mexico. For explanation of plots see Fig. 3.

(I) *Shape of frontal bone* (Fig. 8). — The posterior margin of this bone is curved (coded 0) in most of the island and mainland mice, but in certain populations (*stephani*, *boylei*) it usually is sharply angular (coded 1).

(II) *Position of nasal bones*. — In *stephani* and *boylei* the nasals extend posteriorly to or beyond the premaxillaries (0) (Fig. 9A'), while in all other populations the nasal bones do not reach the level of the posterior extension of the premaxillaries (1) (Fig. 9A).

(III) *Shape of posterior margin of nasals*. — The posterior margin of the two nasal bones is rounded or bluntly pointed (0) (Fig. 9A'), or squared (1) (Fig. 9A). This character is variable among mice on the eastern Gulf islands and among mainland populations of *eremicus*. Squared nasals are particularly prominent among the three populations of *interparietalis*.

(IV) *Shape of interparietal bone*. — Mice from populations of *guardia* exhibit a

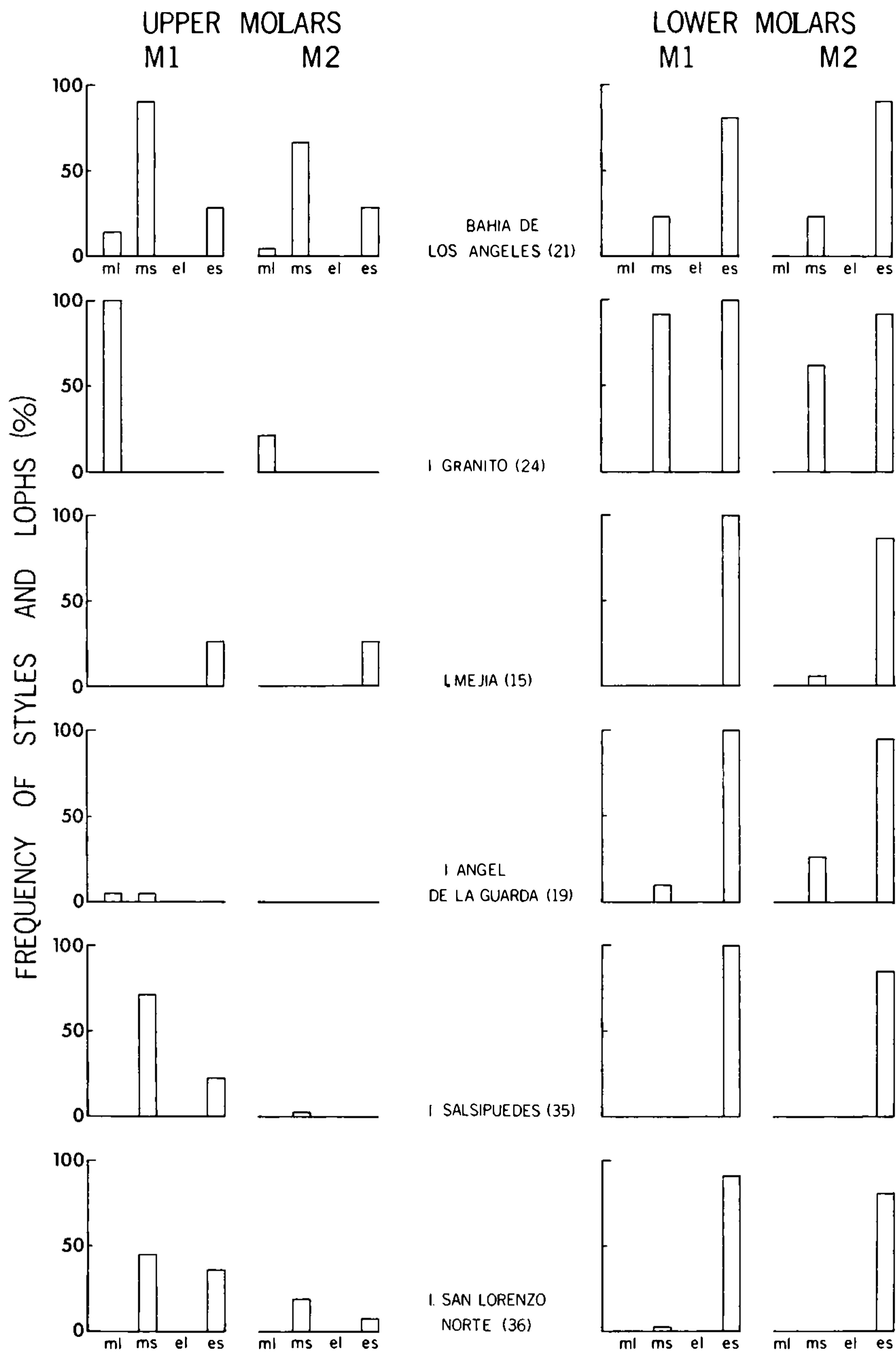

Figure 6. Frequencies of styles (stylids) and lophs (lophids) among *Peromyscus* on northern island and mainland areas in and adjacent to the Gulf of California, Mexico. Sample sizes are indicated in parentheses. Data for additional mainland populations are presented in Table 1.

relatively small, triangular interparietal bone (0) (Fig. 9B), while the bone in remaining insular forms generally is strap-shaped (1) (Fig. 9B' and B'').

(V) *Lateral bony extensions of interparietal* (Fig. 9). — Populations of *guardia boylei*, and *stephani* commonly have small bony extensions of the interparietal bone that extend outward on each side toward the squamosals (1). The remaining island and mainland populations almost always lack these elements (0).

(VI) *Position of squamosals*. — *P. interparietalis*, *stephani*, and *boylei* from Isla San Pedro Nolasco have relatively flattened skulls. The squamosal bones in these forms are slanted dorso-medially (1). This trait is not evident (0) in other populations examined and the skulls are inflated. This trait is indicated in Fig. 8 by the enlarged appearance of the squamosals.

(VII) *Shape of mesopterygoid fossa*. — In most island and mainland forms the pterygoid bones adjacent to the fossa are straight (0) (Fig. 9C), but in *guardia* (Fig. 9C') the

THIS PAGE IS LOCKED TO FREE MEMBERS
Purchase full membership to immediately unlock this page

FORGOTTEN BOOKS

FULL MEMBERSHIP

797,885 Books!
All you can read
for only
\$8.99/month

Continue

*Fair usage policy applies



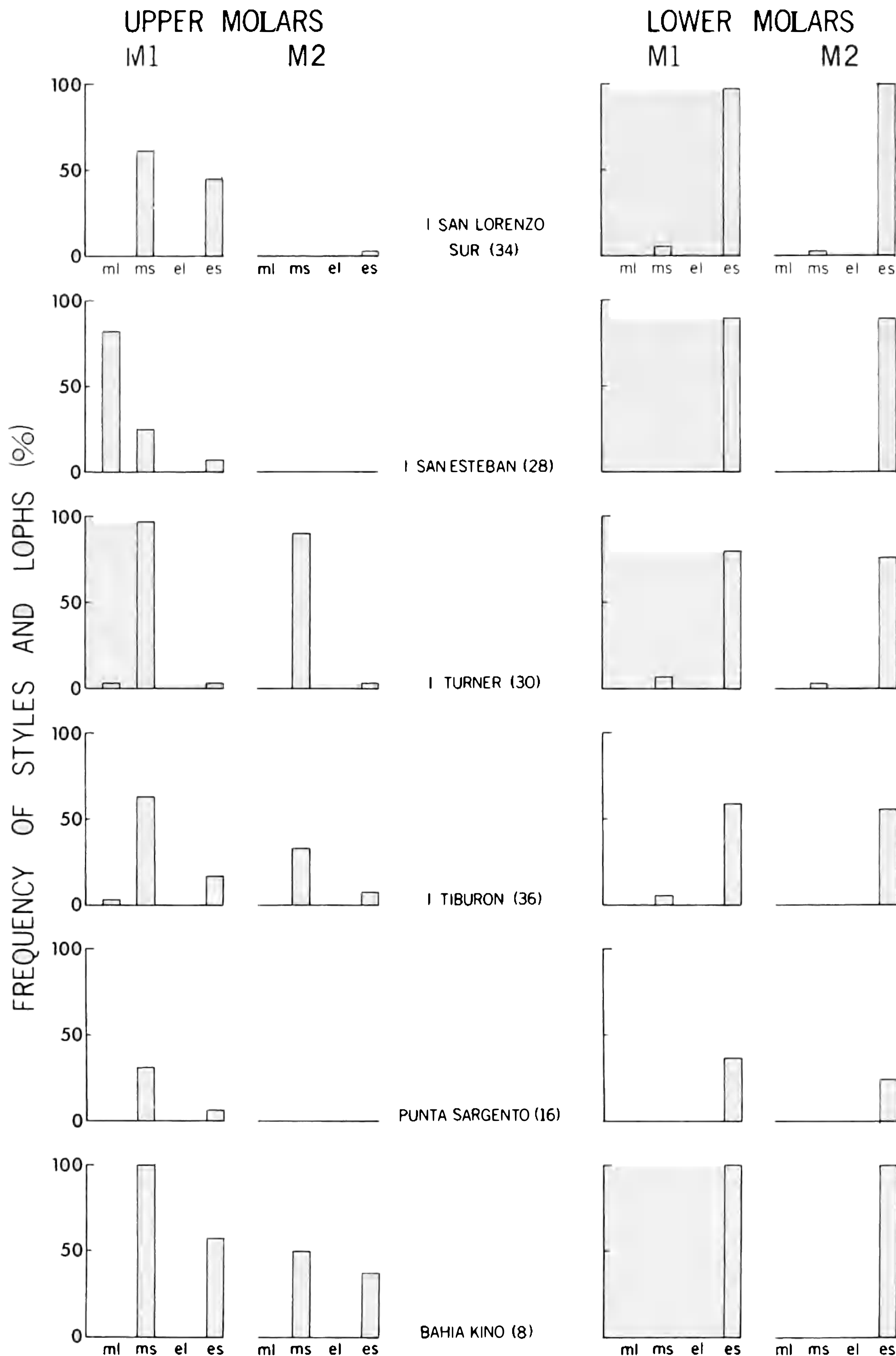

Figure 7. Frequencies of styles (stylids) and lophi (lophids) among *Peromyscus* on northern island and mainland areas in and adjacent to the Gulf of California, Mexico. Sample sizes are indicated in parentheses. Data for additional mainland populations in Table 1.

lateral bony extensions of the interparietal, while those from the Lorenzo island group (*interparietalis*) differ from other island and mainland forms chiefly by the squarish posterior margin of the nasals and the flattened braincase. The forms from Islas Turner (*collatus*) and Tiburon (*eremicus tiburonensis*) closely resemble mainland *eremicus* in all features.

Post-cranial skeletons of all island and several mainland populations were examined, but no important variation in shape or position of bones was evident. However, differences in number of caudal vertebrae were observed (Fig. 10). Mice from mainland populations are more variable in this feature than those from the islands. In certain populations (e. g., *guardia*) the number of caudal vertebrae seems to be fixed. However, sample sizes generally are small, and conclusive statements must await additional data.

Pelage. — Three pelage features were discernible. These characters and their character

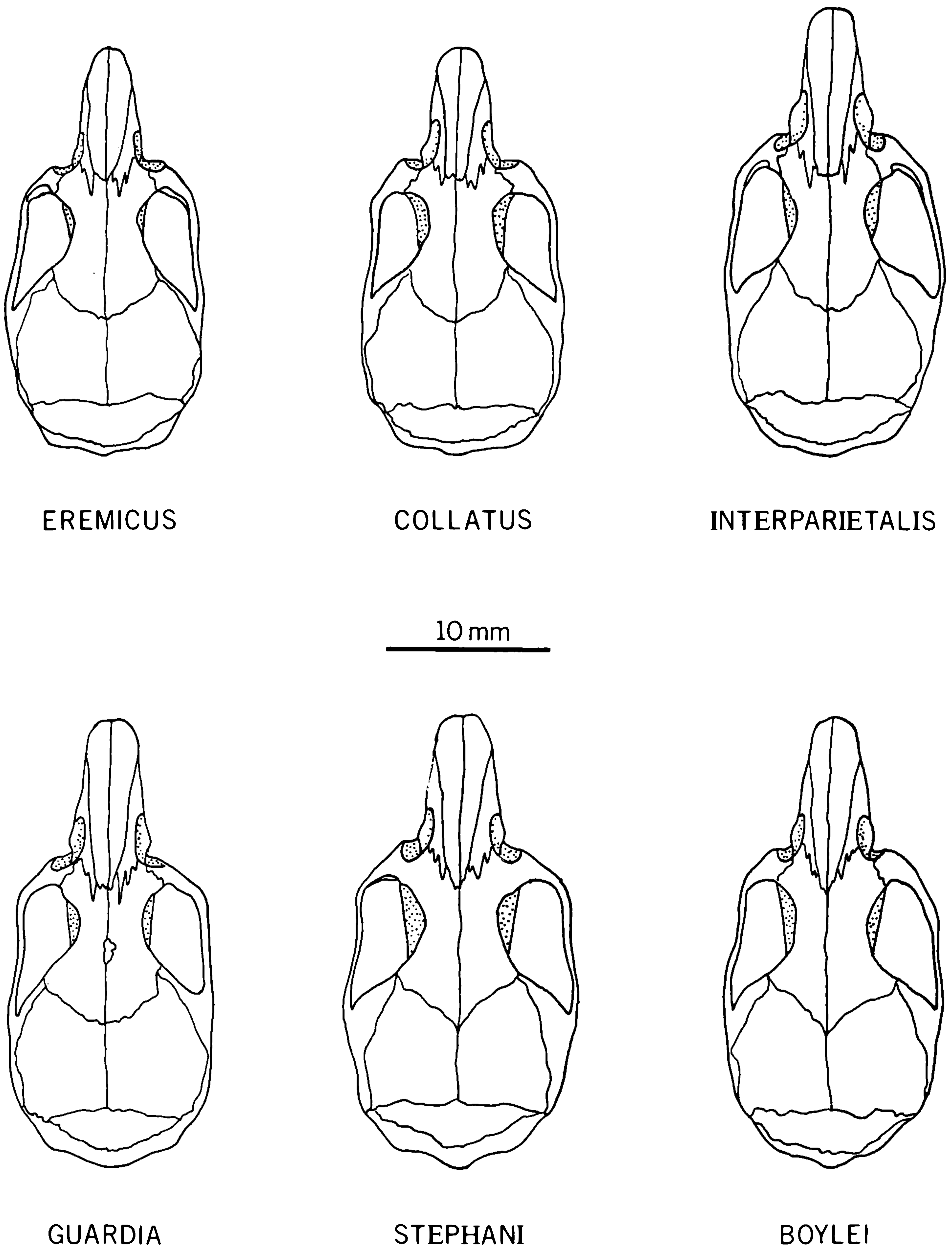

Figure 8. Dorsal skull views of six examples of *Peromyscus* from areas in and adjacent to the northern part of the Gulf of California, Mexico.

states are as follows: (IX) extent of tegumentary attachment on the tail (skin tightly attached to underlying tissue, 0; skin loosely attached and easily removed, 1); (X) hairiness of the tail (scantly haired, 0; well haired, 1); (XI) occurrence of gray facial coloration (absent, 0; present, 1).

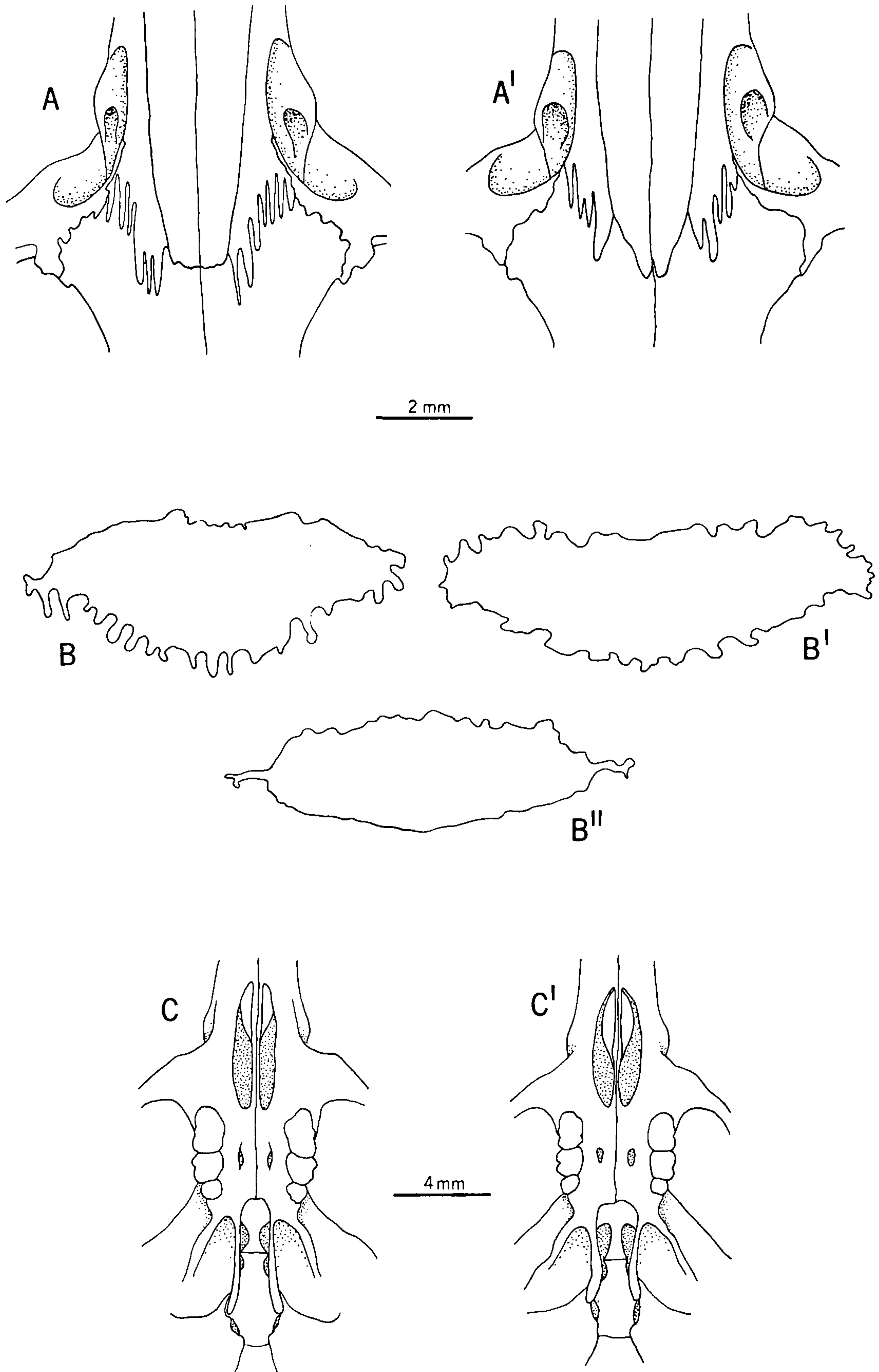

Figure 9. Views of: the dorsal aspect of the frontal region of the skull in *Peromyscus interparietalis* (A) and *P. stephani* (A'); interparietal bones of *P. guardia* (B), *P. interparietalis* (B'), and *P. stephani* (B''); and midventral region of the skull in *P. interparietalis* (C) and *P. guardia* (C'). For characters pertinent to these illustrations see text.

THIS PAGE IS LOCKED TO FREE MEMBERS
Purchase full membership to immediately unlock this page

DELVE INTO FANTASY, MAGIC, MYTHOLOGY & FOLKLORE

Forgotten Books'
Full Membership gives
access to 797,885 ancient
and modern, fiction and
non-fiction books.

Continue

*Fair usage policy applies

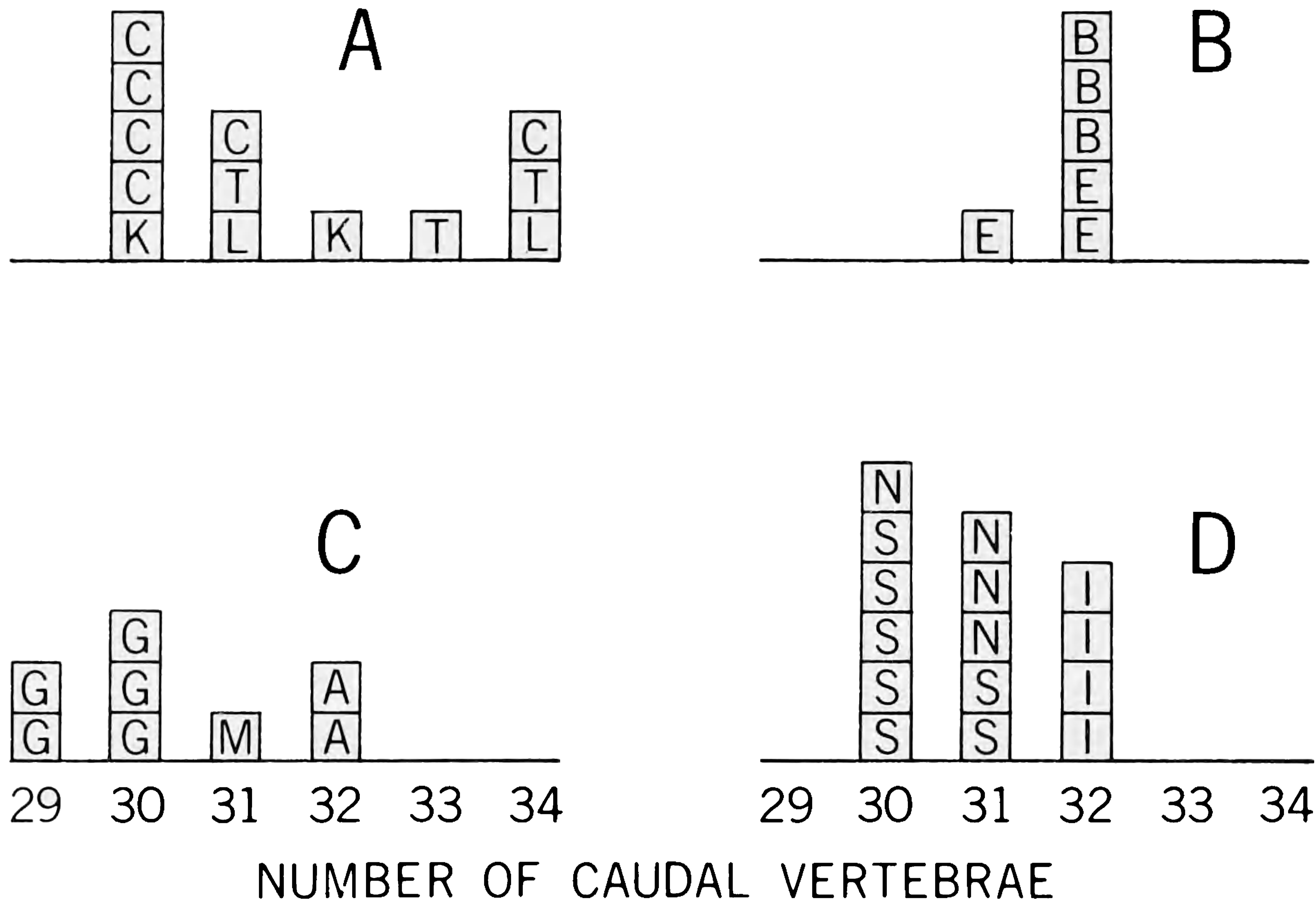

Figure 10. Number of caudal vertebrae in populations of *P. eremicus* and *P. collatus* (A), *P. boylei* and *P. stephani* (B), *P. guardia* (C), and *P. interparietalis* (D). Letter designations are as follows: A — Isla Angel de la Guarda; B — *P. boylei*; C — I. Turner; E — I. San Esteban; G — I. Granito; I — I. San Lorenzo Sur; K — Bahia Kino; L — Bahia de los Angeles; M — I. Mejia; N — I. San Lorenzo Norte; S — I. Salsipuedes; T — I. Tiburon.

Pelage characters serve chiefly to distinguish *stephani* and *boylei* from other forms. Only in *stephani* and *boylei* is the tail well haired and loosely attached. Pelage coloration is similar among the island and mainland mice, except that mice from Isla Mejia and Presa Obregon, where dark substrates occur, are darker than other populations. Few other pelage differences are found among the remaining populations, although certain populations (e.g., mainland *eremicus*) show considerable variation in the expression of gray on the face (Table 2).

Morphology of phallus. — The island populations exhibit both complex and simple peromyscine phallic types (Figs. 11 and 12). Phalli of specimens from Isla San Esteban (*stephani*) are complex and closely resemble *boylei* in all features. Those of the remaining island forms and mainland *eremicus* are relatively simple. Accouterments, such as ventral and dorsal lappets, protrusible tip of glans, and cartilaginous tip of baculum, are poorly developed or absent.

Specimens from the *guardia* group of islands have phalli that are morphologically intermediate between complex and simple types. A protrusible tip is present but not well developed, and dorsal lappets and a small cartilaginous tip also are present. Phalli of forms from Islas Tiburon and Turner, and the Lorenzo island group (*interparietalis*), closely resemble mainland *eremicus*, except that phalli of *interparietalis* are larger and six of seven *interparietalis* from Isla Salsipuedes and one of six *eremicus* from Bahía de los Angeles, Baja California, have ventral lappets (see Fig. 11 and Table 2). It is not clear whether these structures in the two latter populations are homologous, however, because the lappets in the specimen from Bahía de los Angeles are separated from the adjacent tissue by a simple

for *eremicus*, *crinitus*, and some populations of *maniculatus* by Brown and Welser (1968). The mobility for the three populations of *interparietalis* (ca. 94) also differs from the other forms studied here. In addition, the mobility obtained for albumin in *boylei* and *stephani* (90) does not correspond to the value (84) given for one individual of *boylei* by Brown and Welser, suggesting that an albumin polymorphism may exist in that species. Jensen (pers. comm.) has noted polymorphisms of albumin in *boylei* from northern Arizona. No intra-population variation was noted in this study.

Although direct comparisons are not possible, the positions of the albumin band in *interparietalis* and *guardia* correspond favorably to densitometer tracings of this band (Brand and Ryckman, 1969) except that those authors report a difference between albumin of *interparietalis* from Isla Salsipuedes and from the San Lorenzos (a mixed sample from San Lorenzo Sur and San Lorenzo Norte). Further investigation of this discrepancy is required.

Karyology.— All members of the genus *Peromyscus* so far examined have a diploid number of 48 chromosomes regardless of the proportion of acrocentrics in the complement (Hsu and Arrighi, 1966, 1968). The populations studied here are no exception. There also is considerable variation between species as regards morphology of the chromosomes. The populations examined here differ in the following characters (sample sizes given in Table 2):

(XXV) *Number of autosomal acrocentrics*.— There are no acrocentric chromosomes in *merriami*, *eremicus*, *interparietalis*, and *collatus* (0); most are either submetacentric or subtelocentric. *P. guardia* has one pair of small acrocentrics (1), while *stephani* and *boylei* each has 20 pairs (2).

(XXVI) *Morphology of the X chromosome*.— In most populations, including *merriami*, *eremicus*, *interparietalis*, *stephani*, *boylei*, and *guardia*, this chromosome has unequal arms (0). Most have a large submetacentric X chromosome, but in *guardia* from Isla Mejía it is a large subtelocentric. *P. collatus* has a large metacentric X chromosome (1). The morphology of this chromosome is subject to some variation both locally and geographically. For example, in *eremicus* it occasionally appears almost as a metacentric (cf. Hsu and Arrighi, 1968), whereas in *guardia* it varies from a submetacentric to subtelocentric condition. Although this character is employed beyond for purposes of assessing overall similarity, additional data may prove it to be unsuitable for taxonomic use.

(XXVII) *Morphology of the Y chromosome*.— This chromosome is a medium-sized acrocentric (0) in *guardia*, has unequal arms (1) in *eremicus* and *merriami* (medium subtelocentric), *interparietalis* and *collatus* (medium submetacentric), and is a medium metacentric in *stephani* and *boylei* (2). Hsu and Arrighi (*loc. cit.*) reported that the one individual of *eremicus* from Isla Tiburon they examined had a small acrocentric Y chromosome. However, examination of a photograph of that karyotype reveals that this chromosome is a subtelocentric according to the classification used here.

The fundamental numbers of chromosomes in the island and mainland forms are: *guardia* 90, *interparietalis* 92, *collatus* 92, *eremicus* 92, *merriami* 92, *stephani* 52, *boylei* 52. Karyotypes are illustrated in Figures 15 and 16.

BREEDING

Attempted matings between different island and mainland forms are given in Table 3. The breeding colony of *interparietalis* from Islas Salsipuedes and San Lorenzo Norte was obtained in 1967. Consequently more matings of those populations were made. Unless otherwise noted, results of crosses in the following discussion refer also to reciprocal

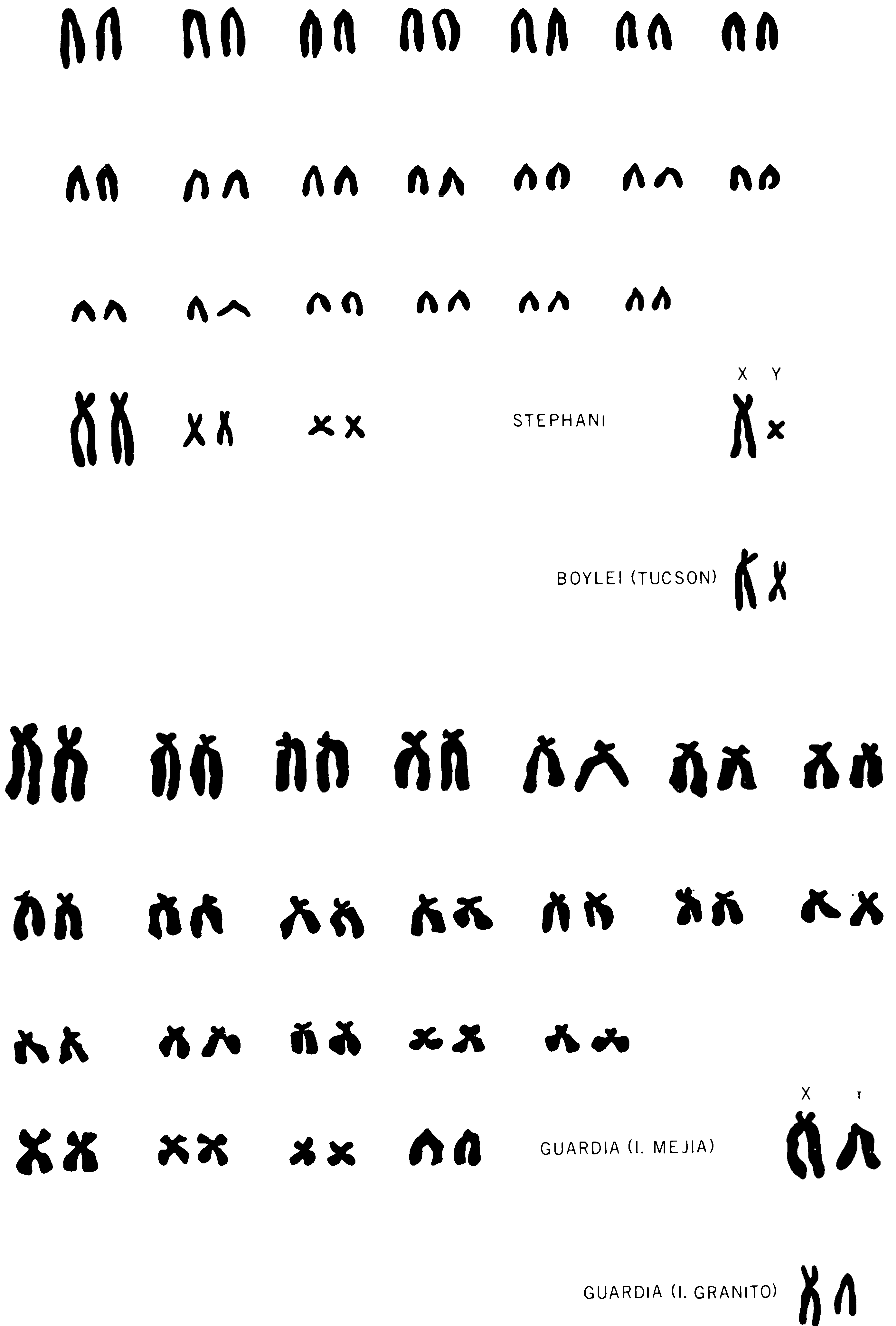

Figure 15. Karyotypes of *P. stephani* and *P. guardia* from Isla Mejía; and sex chromosomes of *P. boylei*, and *P. guardia* from Isla Granito.

THIS PAGE IS LOCKED TO FREE MEMBERS
Purchase full membership to immediately unlock this page

FORGOTTEN BOOKS

FULL MEMBERSHIP

797,885 Books!
All you can read
for only
\$8.99/month

Continue

*Fair usage policy applies



certain forms have the potential for interbreeding in the wild, close relationship of those populations is evident.

Table 3. Attempted matings of island and mainland *Peromyscus*. Numbers in parentheses represent reciprocal crosses.

MALES	<i>eremicus</i> : Bahía Kino	Bahía de los Angeles	Tiburón	<i>collatus</i> : Turner	<i>guardia</i> : Angel de la Guarda	Granito	Mejía	<i>interparietalis</i> : Salsipuedes	San Lorenzo Norte	San Lorenzo Sur	<i>stephani</i> : San Esteban	<i>boylei</i> : San Pedro Nolasco	near Tucson
FEMALES													
<i>eremicus</i> :													
Bahía Kino	1	2(1)	1(0)	2(1)	—	1(1)	—	—	—	—	—	—	—
Bahía de los Angeles		3	—	1(1)	—	0(2)	—	—	2(1)	0(1)	—	—	—
Tiburón			2	1(1)	—	—	—	—	—	—	—	—	—
<i>collatus</i> : Turner				1	—	—	—	—	—	1(1)	—	—	—
<i>guardia</i> :													
Angel de la guarda					1	1(0)	—	—	—	—	—	—	—
Granito						2	1(1)	—	—	1(1)	—	—	—
Mejía							1	—	—	—	—	—	—
<i>interparietalis</i> :													
Salsipuedes								3	3(1)	2(1)	—	—	—
San Lorenzo Norte									6	2(3)	—	—	—
San Lorenzo Sur										1	—	—	—
<i>stephani</i> :													
San Esteban											2	0(1)	1(1)
<i>boylei</i> :													
San Pedro Nolasco												1	—
near Tucson													2

EVOLUTION OF THE ISLAND FORMS PHYLETIC RELATIONSHIPS

A total of 27 serologic, karyologic, osteologic, and other morphologic characters was treated by numerical taxonomic methods, first by a phenetic clustering technique, and then by the quantitative phyletic method (Kluge and Farris, 1969). The first step is the construction of a Prim Network (Prim, 1957; Kluge, in press; see also Edwards and Cavalli-Sforza, 1964) in which only phenetic differences (*sensu* Farris, 1967) between the island and mainland populations, or OTU's (Operational Taxonomic Units; see Sokal and Sneath, 1963), are determined. Two Prim Networks are presented (Figs. 17 and 18). The character states used to describe the OTU's are sample means (data for every character were not available for all individual specimens). Distances between OTU's (interval lengths) represent the sums of character differences between OTU's. The Prim Network connects the OTU's with minimum total interval lengths. There is no directionality implicit in the network, and angles of branching events are arbitrary. The first network (Fig. 17) includes data derived from all but serologic and karyologic characters. The second network (Fig. 18) includes only those populations for which complete data were obtained (sufficient data regarding characters of chromosomes and blood proteins were not available for *crinitus*).

Data regarding phalli for *crinitus* and mainland *boylei* and blood proteins and

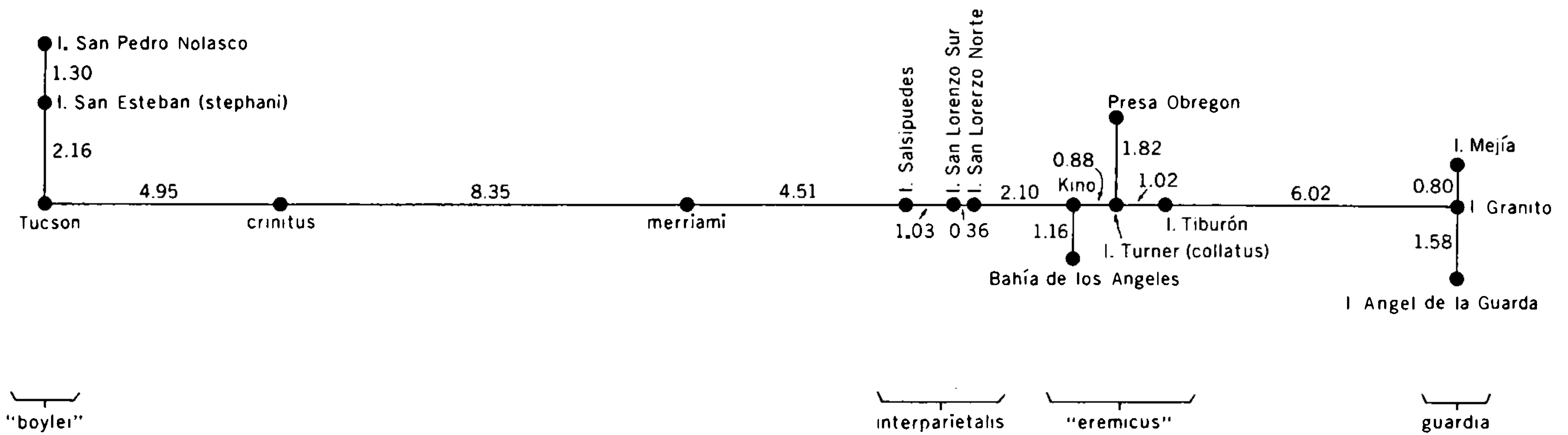

Figure 17. Prim Network computed from data derived from osteology, phallic morphology, pelage, and soft anatomy in *Peromyscus* on northern island and mainland areas in and adjacent to the Gulf of California, Mexico. The interval lengths represent *unweighted* measures of the sums of character differences between OTU's. The network length is 38.04.

karyotypes for *merriami* were obtained from different populations than were data for other features in those species. Their inclusion is justified for comparative purposes because the above characters are relatively invariable geographically, and because even considerable variation in the above structures alters only the interval length and not the branching sequences. Consequently, the data are assumed to be representative.

Four distinct clusters are evident in each diagram: (1) a group consisting of populations of mainland *eremicus* and insular forms from Tiburón and Turner (labeled "*eremicus*"); (2) a cluster comprised of the three island populations of *interparietalis*; (3) a group composed of the three island forms of *guardia*; and (4) a group consisting of mainland and island *boylei* (Tucson and Isla San Pedro Nolasco) and the population from Isla San Esteban (*stephani*) (labeled "*boylei*"). The populations of *crinitus* (Fig. 17 only) and *merriami* are located intermediate to *boylei*- and *eremicus*-like forms on the networks.

The degree of phenetic similarity between the *boylei*-like forms and the remaining island and mainland forms clearly separates the former populations from the latter. They evidently are distantly related. Without doubt, *stephani* exhibits closest affinities to *boylei*. To my knowledge, *boylei glasselli* (Isla San Pedro Nolasco) and *stephani* comprise the only two island derivatives of *boylei* in the Gulf. Note the differences in the Prim Networks, especially for populations of *interparietalis* and *eremicus*, that result from the addition of data on serology and karyology.

In the quantitative phyletic method a Wagner Diagram (Farris, 1970) was used to depict interval lengths (patristic differences; *sensu* Farris, 1967) and branching events (Fig. 19). The Wagner Diagram differs from the Prim Network in three ways: (1) each character is weighted *a priori* by the mean value of the reciprocal of the intrapopulation standard deviation over all OTU's (i.e., conservative characters are more heavily weighted; see Farris, 1966; Kluge and Farris, 1969); (2) hypothetical intermediates are generated to minimize total interval length (i.e., to maximize parsimony); and (3) a hypothetical ancestor is chosen, thus giving directionality to the diagram¹. The intervals on the diagram represent the sums of *weighted* character differences between OTU's.

Populations representing *eremicus*, *merriami*, *interparietalis*, *collatus*, and *guardia* were examined for purposes of ascertaining phylogenetic relationships. These forms exhibit close morphologic and zoogeographic similarities and probably form a mon-

¹The character standard deviations, weighted character state values, and character state values for the hypothetical ancestor and generated intermediates, are filed with the National Auxiliary Publication Service of the American Society for Information Science, and may be obtained by ordering NAPS Document 01267 from ASIS National Auxiliary Publication Service, CCM Information Corp., 909 Third Ave., New York, N.Y. 10022, remitting \$5 per photocopy or \$2 per microfiche copy.

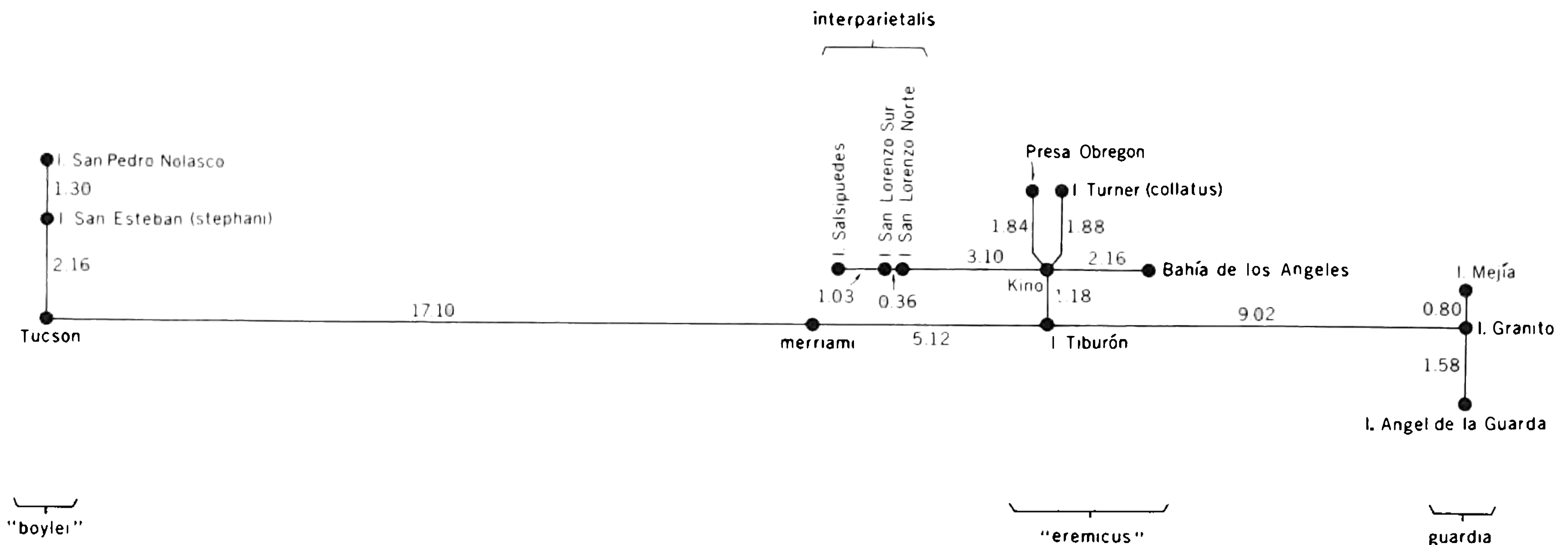

Figure 18. Prim Network computed from data derived from all coded characters (features in Fig. 17 plus data from serology and karyology) in *Peromyscus* on northern island and mainland areas in and adjacent to the Gulf of California, Mexico. The interval lengths represent *unweighted* measures of the sums of character differences between OTU's. The network length is 48.63.

ophyletic group. They are evidently only distantly related to *boylei*, *crinitus*, and other continental species not studied in detail here. Nineteen of the original 27 characters were used in this analysis. The other eight characters (II, IX, X, XVIII, XIX, XX, XXII, and XXIV) serve only to distinguish *eremicus*-like forms from *boylei*-like forms. Characters of *Peromyscus eremicus* were chosen as ancestral for *eremicus*-like forms for the following reasons: (1) zoogeographically, *eremicus* represents the only species of *Peromyscus* that is present on the mainland of both sides of the Gulf, and it seems reasonable to assume that the island populations (excepting *stephani*) resulted from isolation of a mainland *eremicus*-like progenitor; and (2) the species shares the most characters in common with all the insular forms with the result that populations of this species are located centrally to other similar forms on the Prim Network. Assuming that evolution from a primitive ancestor takes place in more than one direction (i.e., it is radiative) and at approximately similar rates in major phyletic lines, then a population (or populations) located near the center of the Prim Network would seem to be the best approximation to the ancestral condition in the absence of unequivocal evidence. Thus, *eremicus*, or more likely a progenitor of similar characteristics, is here considered the ancestral type. Mean values of the character states for mainland populations of *eremicus* were given to the hypothetical ancestor.

From the available data, it is not possible to ascertain which mainland *eremicus* are most like the ancestral form; all populations, and particularly those of *P. e. eremicus*, which occurs on the coastal areas surrounding the northern portion of the Gulf, are very similar morphologically. The close phenetic similarities of mainland populations result in the compact cluster on the Prim Networks (Figs. 17 and 18). On zoogeographic grounds, however, it seems likely that western island populations are derived from Baja Californian *eremicus*, whereas populations on the eastern Gulf islands are probably derived from Sonoran *eremicus*. The affinities of other mammals on eastern and western Gulf islands correspond closely to mainland species of the eastern and western sides of the Gulf, respectively (Table 4). Similar relationships are shown by peromyscines on other Gulf islands (Lawlor, in press), and by the amphibians and reptiles in the Gulf (Soulé and Sloan, 1966).

It is clear from the phylogeny presented in Fig. 19 that, with the exception of *merriami*, *interparietalis* and *guardia* are the most divergent of the *eremicus*-like forms. Populations from Tiburón (*eremicus tiburonensis*) and Turner (*collatus*) are not far

THIS PAGE IS LOCKED TO FREE MEMBERS
Purchase full membership to immediately unlock this page

DELVE INTO FANTASY, MAGIC, MYTHOLOGY & FOLKLORE

Forgotten Books'
Full Membership gives
access to 797,885 ancient
and modern, fiction and
non-fiction books.

Continue

*Fair usage policy applies

ventral lappets. The evidence further indicates that acrocentric chromosomes are derived from bi-armed chromosomes in Gulf *Peromyscus*. In *guardia*, the Y chromosome and one pair of autosomes are acrocentric. No other island or mainland forms studied, other than *crinitus* (Hsu and Arrighi, 1968), *boylei*, or *stephani*, have acrocentric chromosomes, and in the latter species nearly the entire complement of chromosomes are acrocentric (only the sex chromosomes and three pairs of autosomes are bi-armed).

Whether the trends noted above are characteristic of evolutionary changes of these features in other peromyscines or in other rodents is a moot question, but this may be the case in the development of accouterments in the phallus of *P. eva* (Lawlor, in press). The trends may represent reversals from the normal pattern of change in *Peromyscus*. In any event, the overwhelming evidence based on overall similarity indicates that the phalli, dentition, and chromosomes of *guardia* and *interparietalis* did evolve in the above ways. If the alternative hypothesis is invoked, namely that *guardia* and *interparietalis* are considered derivatives of an ancestor having a complex phallus and dentition and a chiefly acrocentric chromosome complement (e.g., a *crinitus*-like form), then convergences of many other characters must have occurred (e.g., osteologic and pelage characters, etc.). The latter seems highly unlikely. Moreover, the probability is quite low that such convergences occurred in all three populations of *guardia* while in *stephani*, which occurs in seemingly similar habitat on an island that is as well isolated and is of approximately the same age, none are observed. I regard the similarities of *guardia* and *eremicus* as indicators of genetic relationship and view the derivation of *guardia* in the most parsimonious manner, namely that it is derived from an *eremicus*-like progenitor.

Evidence from morphology of chromosomes and male accessory reproductive structures suggests that *eremicus* and closely related species may share characters that are primitive for *Peromyscus*. Members of the subgenus *Haplomylops* (excepting *crinitus*) are the only species having a complete complement of male accessory reproductive features (Linzey and Layne 1969). In all other species of the genus one or more elements are absent or vestigial. Except in *guardia*, acrocentric chromosomes are absent in mice of the subgenus. Although practically nothing is known about chromosome evolution in *Peromyscus*, particularly in view of the fact that Robertsonian fusion cannot be invoked (Hsu and Arrighi, 1966; 1968), the data at least are not inconsistent with the view that the presence of acrocentrics is a derived condition. Hsu and Arrighi (1968) presented a hypothetical phylogeny of *Peromyscus* that describes the evolution of chromosomes as resulting from a primitive acrocentric condition, but they noted (p. 437) that the phylogeny was presented in that manner principally for convenience, stating that chromosome evolution in *Peromyscus* may have occurred in either direction. Information on musculature (Rinker, 1963) also supports the view that *Haplomylops* may be a primitive peromyscine group. Most of the conditions of the musculature that Rinker considered primitive are present in that subgenus. The evidence presented in this study suggests that complexities of the teeth and phallus derive from simple conditions and that acrocentric chromosomes derive from a bi-armed condition, at least in the species examined. Most of the *Haplomylops* studied herein exhibit simple conditions of those structures. These data and those presented above support the contention of Linzey and Layne (1969) that *Haplomylops* contains primitive members of the genus.

HISTORICAL PERSPECTIVE

The deserts of western North America, with which the origin and divergence of *P. eremicus* and related forms are closely associated, resulted chiefly from rain shadows produced by extensive mountain building in that area beginning in the Triassic and

continuing to the Pleistocene (King, 1958). However, adequate conditions to support lowland desert forms like *eremicus* probably did not exist prior to the formation of the North American deserts in mid-Pliocene (Axelrod, 1948). Undoubtedly these deserts were further modified by glacial advances and retreats during the Pleistocene, so that relatively stable desert conditions probably did not arise until early or middle Pleistocene, when successive glacial maxima became milder and interglacial periods were characterized by increasingly drier conditions. Displacement of desert elements by the Madro-Tertiary flora (e.g., thorn-scrub) during glacial advances in the early Pleistocene probably resulted in the separation of prototypes of *merriami* and *eremicus* and accounts for the differences in their habitat preferences today (Lawlor, in press).

The history of the Gulf of California is not well documented. Although certain authors (e.g., Durham and Allison, 1960) consider the Gulf to be as old as the Cretaceous orogeny in North America and that it reached its present configuration by the beginning of the Pliocene, recent investigations of the southern Gulf floor (Larson *et al.*, 1968; Moore and Buffington, 1968) suggest that the majority of crustal movement occurred since middle or late Pliocene. A proto-gulf is indicated, however, by earlier Pliocene fossil beds located in northern parts of the Gulf. In any case, the northern deep-water islands in the Gulf may not have originated until late Pliocene or early Pleistocene. For example, sedimentary beds of relatively recent deposition are known from the Lorenzos (early Pliocene) and Angel de la Guarda (late Pliocene) (Anderson, 1950), indicating that the islands were submerged in a shallow water embayment or saline lake at the time. The geologic relationships of these islands to adjacent submarine troughs suggests that the islands may have resulted partly from elevation along faults (Shepard, 1950). Part of this uplift was probably Pleistocene (*Ibid.*). The present separation of Islas Tiburon and Turner from the Sonoran mainland was likely attained with the last glacial retreat (*ca.* 15,000 years ago).

P. eremicus and related desert forms probably did not originate until formation of the deserts in mid-Pliocene. Consequently, evolution and radiation of this group on mainland and island areas has been relatively recent and no doubt has been substantially affected by displacement and expansion of the lowland deserts during the Pleistocene. In this connection, the suggested origin and radiation of these mice corresponds closely to that described for the lizard genus *Uta* (Ballinger and Tinkle, in press).

ZOOGEOGRAPHIC RELATIONSHIPS

Relationships between *guardia*, *interparietalis*, and *eremicus* are consistent with Banks' (1967) contention that *guardia* and *interparietalis* probably had separate origins from a mainland *eremicus*-like stock. Furthermore, *Peromyscus* has not been taken on two islands (Isla Partida and Raza) that are located between the two groups of islands supporting *guardia* and *interparietalis*, although several people have collected on each (I have collected only on Isla Partida). This suggests that *guardia* and *interparietalis* do not represent isolates of a form once continuously distributed among these islands, but rather that they are of separate mainland origin (*Ibid.*).

The time interval between initial isolation of the island populations from the mainland is probably the principal factor affecting the degree of divergence of northern island forms in the Gulf of California. This seems to be the case for the following reasons: (1) Morphological divergence is at least broadly related to temporal differences in island formation. Angel de la Guarda and its satellite islands, the Lorenzo group of islands, and San Esteban have been separated from the mainland for a considerable length of time. Islas Tiburon and Turner most certainly are no older than late Pleistocene. *P. eremicus*-like forms on the older groups of islands (*guardia* and *interparietalis*) are more divergent

than populations on younger islands (*eremicus tiburonensis* and *collatus*). (2) Apparently gene flow is minimal or absent among islands and between islands and the mainland. Differences persist among populations separated by very short distances, and because of habitat similarities and high population densities these differences probably are not attributable to presently existing differential selection coefficients or genetic drift. For example, it was pointed out above that populations from Islas San Lorenzo Sur and San Lorenzo Norte differ significantly ($P < .05$) in many morphometric characters; yet these islands are separated by 100 yards at most, and at low tide half-submerged rocks project above the water for almost the entire distance. Furthermore, ventral lappets on the phallus persist in most individuals of *interparietalis* from Isla Salsipuedes, while this feature evidently is absent in other nearby populations of that species. Isla Tiburon is separated from the Sonoran mainland by as little as two miles and by shallow water (only six meters at certain places); yet differences in phalli (and perhaps in karyotypes) are evident between the mice there and on the adjacent mainland (e.g., Bahía Kino); similar differences also persist between mice on Tiburon and those on Turner. In *guardia*, dramatic differences in dental patterns and morphometric characters are evident. It appears that distance effects owing to differential gene flow, although perhaps important in early colonization and establishment of the island populations, have been relatively unimportant in shaping present characteristics of the island forms. (3) Differences among island populations seemingly are not explicable only in terms of habitat differences. The northern part of the Gulf is marked by overall floral uniformity (Shreve and Wiggins, 1951; Felger, 1966). In addition, xeric rocky habitats are characteristic of all the islands inhabited by *Peromyscus*.

Table 4. Zoogeographic relations of species of mammals on northern islands in the Gulf of California. Only island species having mainland relatives on one side of the Gulf are compared. No mammals other than *Peromyscus stephani* and *Rattus norvegicus* are known from Isla San Esteban.

Locality	<i>Perognathus spinatus</i>	<i>Perognathus intermedius</i>	<i>Perognathus penicillatus</i>	<i>Neotoma lepida</i>	<i>Neotoma albigula</i>	<i>Dipodomys merriami</i>	<i>Lepus alleni</i>
Western islands:							
Granito	?			?			
Mejía	X			?			
Angel de la Guarda	X			X			
Salsipuedes	?						
San Lorenzo Norte	X						
San Lorenzo Sur	X						
Eastern islands:							
Tiburon		X	X		X	X	X
Turner		X ¹	?		X ²		
Mainland:							
Baja California	X			X			
Sonora		X	X		X	X	X

¹This population originally was described as *P. penicillatus* (Burt, 1932) but evidently is *intermedius* (Patton, pers. comm.)

²Called *N. varia*, but closely related to *albigula* (Burt, 1932)

THIS PAGE IS LOCKED TO FREE MEMBERS
Purchase full membership to immediately unlock this page

FORGOTTEN BOOKS

FULL MEMBERSHIP

797,885 Books!
All you can read
for only
\$8.99/month

Continue

*Fair usage policy applies



elsewhere (Lawlor, in press; see also Hoffmeister and Lee [1963], and Commissaris [1960]). The additional information regarding blood proteins and karyology and the phenetic and phylogenetic relations of the two species presented here support earlier conclusions that *merriami*, although morphologically distinct, exhibits close affinities to *eremicus* and is probably derived from a progenitor similar to that species. All of the above species are members of the subgenus *Haplomydomys*.

P. stephani clearly is a close relative of *boylei* and should be placed with *boylei* in the subgenus *Peromyscus*. In my view *stephani* should be retained as a species.

ACKNOWLEDGMENTS

For the loan of specimens I am indebted to the following individuals and their respective institutions: Dr. J. Knox Jones, Jr., Museum of Natural History, University of Kansas; Dr. E. Lendell Cockrum, Department of Zoology, University of Arizona; Dr. Seth Benson, Museum of Vertebrate Zoology, University of California, Berkeley; Drs. Richard H. Manville and John L. Paradiso, United States National Museum; Dr. Joseph R. Jehl, Jr., San Diego Natural History Museum; Dr. Thomas R. Howell, University of California, Los Angeles; and Dr. Robert T. Orr, California Academy of Science. For manuscript review and counsel I am especially grateful to Drs. William H. Burt, Claude W. Hibbard, Donald W. Tinkle, Morris Foster, Emmet T. Hooper, and Arnold G. Kluge of the Museum of Zoology, University of Michigan; to Carl Welser, Mammalian Genetics Center, University of Michigan; and to Albert Bennett, intrepid explorer. I also extend thanks to my wife, Bertie, for help in preparation of the manuscript.

Support for research and field investigations was provided in part by a U.S. Public Health Service predoctoral fellowship (No. 1-F1-GM-37, 761-01), by a grant to the University of Michigan from the National Science Foundation for research in Systematic and Evolutionary Biology (NSF GB-6230), and by a research grant from Sigma Xi.

SPECIMENS EXAMINED

Specimens employed for analysis of blood proteins and karyology were collected alive and maintained at the University of Michigan. Most of these mice are preserved in the Museum of Zoology, even though not cited below. Sample sizes and localities from which these specimens were obtained are given in the appropriate tables above. Only specimens obtained for purposes of examining morphologic features of the pelage, phalli, osteology, and soft anatomy are listed below. Where appropriate, numbers in parentheses identify the localities on the map (Fig. 1).

P. boylei.— ARIZONA: Marble Park, Catalina Mts., Pima Co. (9), 24 (UMMZ). SONORA: Isla San Pedro Nolasco (14), 7 (UMMZ).

P. crinitus.— CALIFORNIA: Paiute Creek, Inyo Mts., Inyo Co. 28 (UMMZ).

P. eremicus.— BAJA CALIFORNIA: Turtle Bay (1), 10 (3 SD, 3 USNM, 4 UMMZ); Barril (2), 10 (SD); Bahía de los Angeles (3), 23 (2 SD, 1 UCLA, 20 UMMZ); San Francisquito (4), 16 (USNM); El Marmol (5), 14 (CAS); San Telmo (6), 7 (UMMZ). CALIFORNIA: Escondido, San Diego Co. (7), 21 (KU). SONORA: Puerto Peñasco (8), 20 (17 SD, 3 UA); Imuris (10), 9 (KU); Puerto Libertad (11), 20 (2 KU, 18 SD); Punta Sargento (12), 24 (UCLA); Bahía Kino (13), 14 (2 UA, 6 KU, 6 UMMZ); Presa Obregon (15), 13 (10 KU, 3 UMMZ); Isla Tiburon, 45 (4 CAS, 3 KU, 1 SD, 19 UC, 6 UCLA, 12 UMMZ); Isla Turner, 37 (1 CAS, 4 KU, 3 SD, 15 UCLA, 14 UMMZ).

P. guardia.— BAJA CALIFORNIA: Isla Angel de la Guarda, 28 (11 SD, 10 UCLA, 7 UMMZ); Isla Granito, 40 (7 SD, 33 UMMZ); Isla Mejia, 17 (5 CAS, 3 SD, 1 UCLA, 8 UMMZ).

P. interparietalis.— BAJA CALIFORNIA: Isla Salsipuedes, 48 (1 CAS, 13 SD, 34 UMMZ); Isla San Lorenzo Norte, 41 (19 SD, 22 UMMZ); Isla San Lorenzo Sur, 46 (7 UA, 11 CAS, 16 SD, 7 UCLA, 5 UMMZ).

P. merriami.— SONORA: Presa Obregon (15), 20 (17 KU, 3 UMMZ).

P. stephani.— SONORA: Isla San Esteban, 37 (2 CAS, 1 SD, 19 UCLA, 15 UMMZ).

The locality specified as "near Tucson" for *boylei* (Table 2) refers to Marble Park, Catalina Mts., Pima Co., Arizona, and Molino Canyon, 18 mi. NE Tucson, Catalina Mts., Pima Co., Arizona. The same designation (Table 2) for *merriami* refers to 3/4 mi. SE San Xavier Mission, Pima Co., Arizona.

LITERATURE CITED

Anderson, C. A.

1950. 1940 E. W. Scripps cruise to the Gulf of California. Part I. Geology of islands and neighboring land areas. Mem. Geol. Soc. Amer. 43: viii + 53 pp.

- Axelrod, D. I.
1948. Climate and evolution in western North America during the middle Pliocene time. *Evolution* 2: 127-144.
- Ballinger, R. E., and D. W. Tinkle
The systematics and evolution of the genus *Uta* (Sauria: Iguanidae). Misc. Publ. Mus. Zool., Univ. Michigan, in press.
- Banks, R. C.
1967. The *Peromyscus guardia-interparietalis* complex. *J. Mammal.* 48: 210-218.
- Brand, L. R., and R. E. Ryckman
1969. Biosystematics of *Peromyscus eremicus*, *P. guardia*, and *P. interparietalis*. *J. Mammal.* 50: 501-513.
- Brown, J. H., and C. F. Welser
1968. Serum albumin polymorphisms in natural and laboratory populations of *Peromyscus*. *J. Mammal.* 49: 420-426.
- Burt, W. H.
1932. Descriptions of heretofore unknown mammals from islands in the Gulf of California, Mexico. *Trans. San Diego Soc. Nat. Hist.* 7: 161-182.
- Commissaris, L. R.
1960. Morphological and ecological differentiation of *Peromyscus merriami* from southern Arizona. *J. Mammal.* 41: 305-310.
- Durham, J. W., and E. C. Allison
1960. The biogeography of Baja California and adjacent seas. Part I. Geologic history. The geologic history of Baja California and its marine faunas. *Syst. Zool.* 9: 47-91.
- Edwards, A. W. F., and L. L. Cavalli-Sforza
1964. Reconstruction of evolutionary trees. *Syst. Assoc. Publ.* 6: 67-76.
- Farris, J. S.
1966. Estimation of conservatism of characters by constancy within biological populations. *Evolution*, 20: 587-591.
1967. The meaning of relationship and taxonomic procedure. *Syst. Zool.* 16: 44-51.
1970. Methods for computing Wagner Trees. *Syst. Zool.* 19: 83-92.
- Felger, R. S.
1966. Ecology of the gulf coast and islands of Sonora, Mexico. Ph. D. Thesis, Univ. Arizona, 460 p.
- Hershkovitz, P.
1962. Evolution of neotropical cricetine rodents (Muridae) with special reference to the phylotine group. *Fieldiana Zool.* 46: 1-524.
- Hoffmeister, D. F.
1951. A taxonomic and evolutionary study of the pinon mouse, *Peromyscus truei*. *Illinois Biol. Monog.* 21: x + 104 p.
- Hoffmeister, D. F., and M. R. Lee
1963. The status of the sibling species *Peromyscus merriami* and *Peromyscus eremicus*. *J. Mammal.* 44: 201-213.
- Hooper, E. T., and G. G. Musser
1964a. The glans penis in Neotropical cricetines (Family Muridae) with comments on classification of muroid rodents. Misc. Publ. Mus. Zool., U. Michigan 123: 1-57.
1964b. Notes on classification of the rodent genus *Peromyscus*. *Occas. Papers Mus. Zool., Univ. Michigan* 635:1-13.
- Hsu, T. C., and F. E. Arrighi
1966. Chromosomal evolution in the genus *Peromyscus* (Rodentia: Cricetidae). *Cytogenetics* 5: 355-359.
1968. Chromosomes of *Peromyscus* (Rodentia: Cricetidae) I. Evolutionary trends in 20 species. *Cytogenetics* 7: 417-446.
- King, P. B.
1958. Evolution of modern surface features of western North America. *Publ. Amer. Assoc. Adv. Sci.* 51: 3-60.
- Kluge, A. G.
The evolution and geographical origin of the New World *Hemidactylus mabouia-brookii* complex (Gekkonidae, Sauria). Misc. Publ. Mus. Zool., Univ. Michigan, in press.
- Kluge, A. G., and J. S. Farris
1969. Quantitative phyletics and the evolution of anurans. *Syst. Zool.* 18: 1-32.
- Larson, R. L., H. W. Menard, and S. M. Smith
1968. Gulf of California: a result of ocean-floor spreading and transform faulting. *Science*, 161: 781-784.

- Lawlor, T. E.
1964. The Yucatan deer mouse, *Peromyscus yucatanicus*. Master's Thesis, Univ. Kansas, 45 p.
Distribution and relationships of six species of *Peromyscus* in Sonora and Baja California, Mexico. Occas. Papers Mus. Zool., Univ. Michigan, in press.
- Linzey, A. V., and J. N. Layne
1969. Comparative morphology of the male reproductive tract in the rodent genus *Peromyscus* (Muridae). Amer. Mus. Novitates 2355:1-47.
- Matthey, R.
1951. The chromosomes of the vertebrates. In: M. Demerec (ed.), Advances in genetics 4: 159-180.
- Mearns, E. A.
1897. Descriptions of six new mammals from North America. Proc. U.S. Natl. Mus. 19: 719-724.
- Moore, D. G., and E. C. Buffington
1968. Transform faulting and growth of the Gulf of California since the late Pliocene. Science 161: 1238-1241.
- Osgood, W. H.
1909. Revision of the mice of the American genus *Peromyscus*. N. Amer. Fauna 28: 1-285.
- Patton, J. L.
1967. Chromosome studies of certain pocket mice, genus *Perognathus* (Rodentia: Heteromyidae). J. Mammal. 48: 27-37.
- Preston, F. W.
1962. The canonical distribution of commonness and rarity: Parts I and II. Ecology 43: 185-215 and 410-432.
- Prim, R. C.
1957. Shortest connection networks and some generalizations. Bell Syst. Tech. J. 36: 1389-1401.
- Rasmussen, D. I., J. N. Jensen, and R. K. Koehn
1968. Hemoglobin polymorphism in the deer mouse, *Peromyscus maniculatus*. Biochem. Genetics 2: 87-92.
- Rinker, G. C.
1963. A comparative myological study of three subgenera of *Peromyscus*. Occas. Papers Mus. Zool., Univ. Michigan 632: 1-18.
- Shepard, F. P.
1950. 1940 E. W. Scripps cruise to the Gulf of California. Part III. Submarine topography of the Gulf of California. Mem. Geol. Soc. Amer. 43: viii + 32 p.
- Shreve, F., and I. L. Wiggins
1951. Vegetation of the Sonoran desert. Publ. Carnegie Inst. Wash., 591: xii + 192 p.
- Smithies, O.
1955. Zone electrophoresis in starch gels: group variations in the serum proteins of normal human adults. Biochem. J. 61: 629-641.
- Sokal, R. R., and P. H. Sneath
1963. Principles of numerical taxonomy. W. H. Freeman and Co., San Francisco, 359 p.
- Soule, M., and A. J. Sloan
1966. Biogeography and distribution of the reptiles and amphibians on islands in the Gulf of California, Mexico. Trans. San Diego Soc. Nat. Hist. 14: 137-156.
- Townsend, C. H.
1912. Mammals collected in Lower California with descriptions of new species. Bull. Amer. Mus. Nat. Hist. 31: 117-130.

Department of Biology, Humboldt State College, Arcata, California, 95521.

THIS PAGE IS LOCKED TO FREE MEMBERS
Purchase full membership to immediately unlock this page

DELVE INTO FANTASY, MAGIC, MYTHOLOGY & FOLKLORE

Forgotten Books'
Full Membership gives
access to 797,885 ancient
and modern, fiction and
non-fiction books.

Continue

*Fair usage policy applies

LAMPETRA (ENTOSPHEMUS) LETHOPHAGA, NEW SPECIES, THE NONPARASITIC DERIVATIVE OF THE PACIFIC LAMPREY

CARL L. HUBBS

ABSTRACT.—The Pacific lamprey, *Lampetra (Entosphenus) tridentata*, is now shown to agree with most parasitic species of the Petromyzoniformes in having evolved into a nonparasitic derivative, *L. (E.) lethophaga*. Although the parasitic form ranges widely, from central Baja California around the North Pacific periphery to southern Japan, varying greatly in adult size, the dwarfed nonparasitic form seems to be confined to the contiguous drainage basins of the Pit River (a Sacramento River headwater) in northeastern California, both above and below the Pit River Falls, and to the upper Klamath River system in south-central Oregon. These two drainage basins harbor additional endemic fishes, and have certain other faunal features in common. The distributions of the three nonparasitic lampreys in the drainage basins around the North Pacific appear to be complementary.

L. lethophaga contrasts rather sharply with the dwarfed, probably resident types of *L. tridentata* in the Klamath system, as well as with the large, sea-run populations. However, a specimen from Willow Creek in the Lost River system of Oregon is possibly intermediate between *L. lethophaga* and the dwarf parasitic types in the Klamath River system; and a parasitic form of the same group, of Miller Lake, in a disjunct section of the Klamath River system, is reported to be even more dwarfed than *L. lethophaga*. Some intergradation between the parasitic and nonparasitic stocks is not excluded.

The dentition of the nonparasitic form exhibits features both of reduction and of increased individual variation, probably along with some geographical differentiation.

Like other lampreys, the new species no doubt exists for several years in the larval (ammocete) stage before metamorphosing in the autumn. The gonads ripen as the gut atrophies. The dwarf adults after overwintering appear on circumstantial evidence either (1) to undergo the typical nuptial metamorphosis to spawn in the following spring, or (2) to attain maturity neotenually while retaining the prenuptial state of pigmentation and body form, and to spawn over the summer months, or even after overwintering again.

There are indications that lamprey species are subject to regional diversity, and that some of the speciation has been of a mosaic type.

RESUMEN.—Se demuestra que la lamprea del Pacífico, *Lampetra (Entosphenus) tridentata* concuerda en su evolución con la mayor parte de las especies parásitas de Petromyzoniformes, produciendo un derivado no parásito, *L. (E.) lethophaga*. Las formas parásitas presentan una amplia distribución geográfica, extendiéndose a lo largo de la zona periférica del Pacífico Norte, desde la parte central de Baja California hasta la zona meridional del Japón. Los adultos de estas formas ofrecen una gran variación de tallas. Las formas enanas libres, no parásitas, están al parecer confinadas a las cuencas fluviales contiguas del río Pit (uno de los tributarios de la parte alta del río Sacramento) en la zona nordeste de California, a ambos lados de las cataratas del río Pit, y en la parte alta del sistema del río Klamath en la zona centro-meridional de Oregon. Estas dos cuencas fluviales albergan también otros peces endémicos, presentando así mismo otras características faunísticas comunes. Las tres lampreas no parásitas que habitan las cuencas fluviales que bordean el Pacífico Norte, presentan al parecer una distribución complementaria.

L. lethophaga contrasta notablemente con las formas enanas, probablemente tipos residentes de *L. tridentata* en la red fluvial del Klamath, así como también con las especies de talla grande correspondientes a poblaciones oceánicas. Sin embargo, un ejemplar procedente de Willow Creek, en la red fluvial del río Lost, en Oregon, es posiblemente una forma intermedia entre *L. lethophaga* y los tipos parásitos y enanos del sistema del río Klamath. Una forma parásita de este mismo grupo aparece en el lago Miller (sección disyuntiva de la red fluvial del río Klamath). Se ha establecido ya, que dicha forma es aun más pequeña que *L. lethophaga*. Desde luego no puede excluirse la posibilidad de que exista una intergraduación entre las poblaciones parásitas y libres (no parásitas).

Las formas libres presentan variaciones individuales de reducción o de incremento en la dentición, características probablemente relacionadas con otras diferencias geográficas.

Al igual que sucede en otras lampreas, esta nueva especie permanece indudablemente durante varios años en la fase larval (amoceto) antes de llegar a la metamorfosis, que tiene lugar en el otoño. Al madurar las gónadas, el tubo digestivo se atrofia. Los adultos enanos después de pasar el invierno, evidencian cualquiera de las siguientes circunstancias: 1) que pasan la metamorfosis nupcial típica para así desovar en la primavera siguiente, o 2) alcanzan una madurez neoténica, es decir, retienen la pigmentación y forma del cuerpo de la fase prenupcial, desovando entonces durante los meses de verano, o aún más tarde, después de pasado el invierno.

Las observaciones obtenidas indican que las especies de lampreas presentan diversidad regional, y en algunos casos la especiación corresponde al tipo de mosaico.

Although I discovered a dwarfed, nonparasitic derivative of the Pacific lamprey, *Lampetra (Entosphenus) tridentata* (Richardson) in 1934, in the Pit River system of northern California and in the upper Klamath River system in southern Oregon, and although it has been distinguished by Bond (1961: 14) in key form from *L. tridentata*, from the same river systems, it has not yet been assigned a species-group name. Bond merely designated it "Klamath brook lamprey, *Lampetra* sp." With the particular need of making the name and the status of this form available for a forthcoming treatment of the distribution, phylogeny, and taxonomy of lampreys (Hubbs and Potter, in press), it is now belatedly made known as:

PIT-KLAMATH BROOK LAMPREY

Lampetra (Entosphenus) lethophaga, new species

Entosphenus tridentatus (misidentification).— Rutter, 1908: 120 (material listed from "South Fork Pitt River" only).

Lampetra planeri (misidentification).— Hubbs, 1925: 594 (size of recently transformed specimen from "North Fork of Pitt River").

Lampetra sp.— Bond, 1961: 14 ("Klamath brook lamprey"; "Klamath and Pit River systems").

Holotype, U. Mich. Mus. Zool. 130648, and paratypes, UMMZ 130649, from source of Fall River, a tributary to Pit River, in Shasta County, California (as specified under Location 2, below).

This species is illustrated in Figures 1, 2 A-B, and 6; its range and habitat in Figures 3 and 4; its size in Figure 8. Figures 2 C-D, 3, 5, 7, and 8 pertain in part or *in toto* to related forms.

Diagnosis.— The following diagnosis largely follows the sequence of characters utilized by Hubbs and Potter (in press) in their analysis of the lampreys of the world.

A petromyzonid lamprey agreeing with *Lampetra (sensu lato)* in having: the extraoral teeth not in regular alate rows, the lateral and posterior fields of disc essentially toothless between circumorals and marginals, the teeth of the anterior field few and scattered, none of the teeth villiform, the supraoral markedly dilated, the anterior circumorals normally 5, the total anterior and lateral circumorals usually 13, and the lateral circumorals more or less dilated. Agreeing with subgenera *Lethenteron* and *Entosphenus* in having the laterals connected by the posterior-circumorals, and agreeing with *Entosphenus* in having 4 lateral circumorals on each side, one or more outer posterior circumorals often bifid, the supraoral often with a median cusp, the transverse lingual lamina almost rectilinear and with median cusp not strongly enlarged, and the marginals and posterior circumorals often in an irregular file. Differing from the complex now passing as *Lampetra tridentata* in being nonparasitic (not feeding or growing after the fall metamorphosis, but developing the gonads as the gut atrophies prior to spawning in the next spring or summer, or even later, and then dying), and in being much reduced in size at maturity (less than 170 mm), and in some places (including the type locality) breeding in prenuptial coloration and body form;

THIS PAGE IS LOCKED TO FREE MEMBERS
Purchase full membership to immediately unlock this page

FORGOTTEN BOOKS

FULL MEMBERSHIP

797,885 Books!
All you can read
for only
\$8.99/month

Continue

*Fair usage policy applies



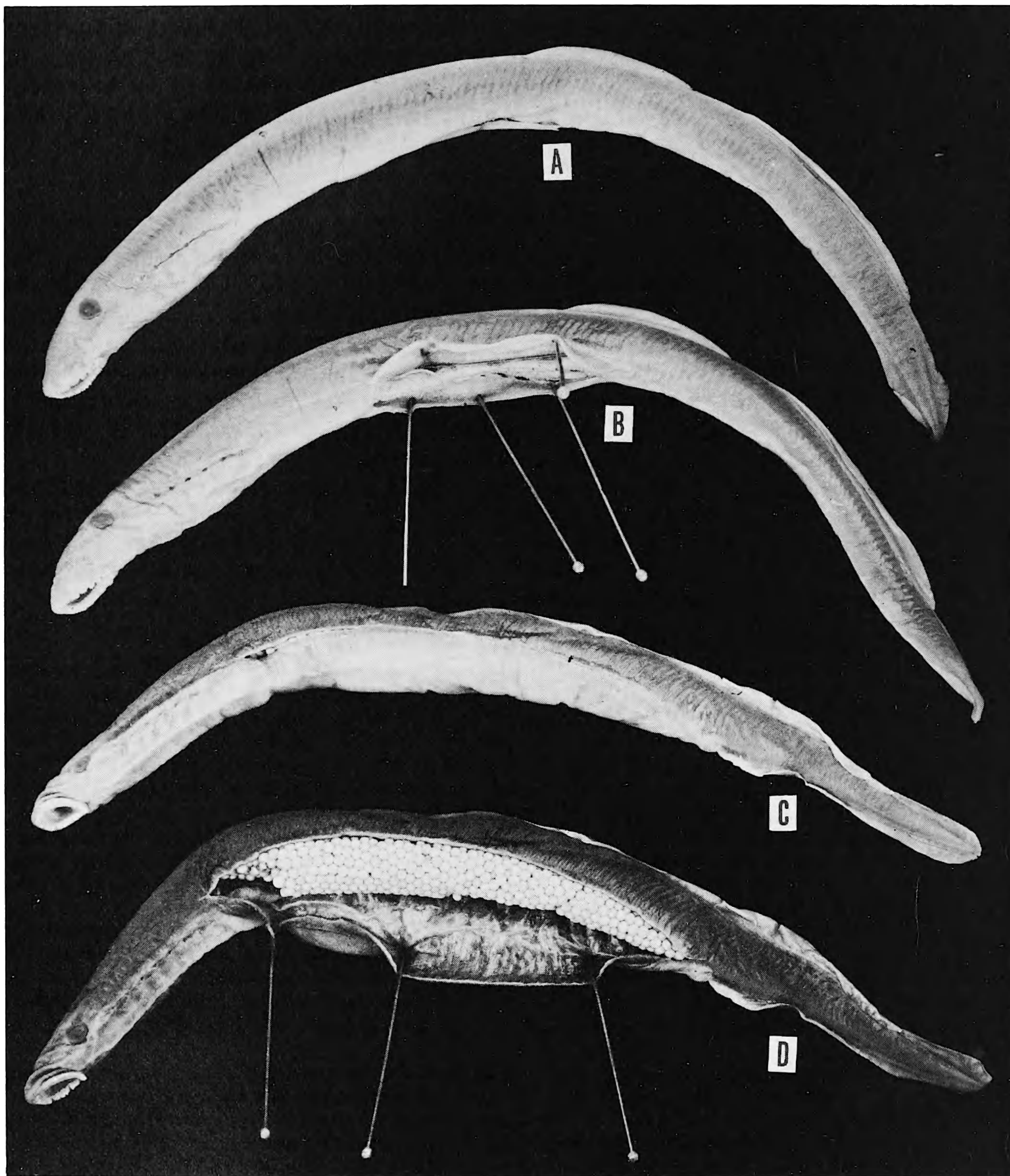

Figure 1. Types of *Lampetra lethophaga*, from head of Fall River, Shasta County, California (Location 2): A, holotype, UMMZ 130648, a mature, neotenic male 128 mm in total length, in side view. B, same specimen, in oblique view, with abdominal wall pinned aside, to show enlarged, lobular testis and atrophic gut bearing signs of hemorrhages. C, paratype, in series UMMZ 130649, a fully mature, neotenic female 116 mm long, in side view. D, same specimen, in oblique view, with abdominal wall pinned aside, to show celome packed full of ripe ova aligned in alate rows.

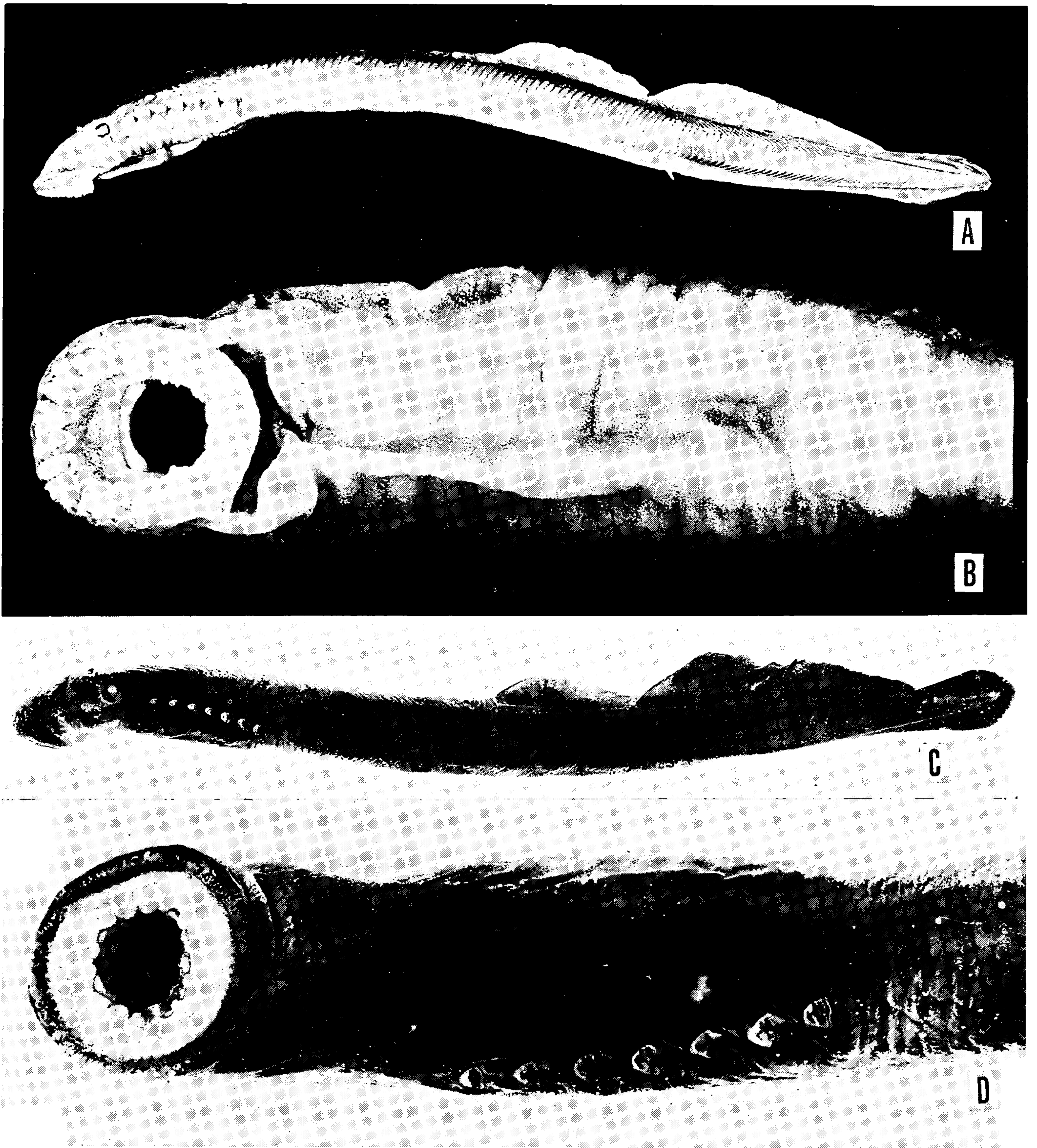

Figure 2. Nuptial males of genus *Lampetra*, subgenus *Entosphenus*: A, *Lampetra lethophaga*, OS 2856 (specimen K0010), 154 mm in total length, in side view; from Crooked Creek, Klamath County, Oregon (Location 11). B, same specimen, in ventral view of head region, enlarged. C, *Lampetra* sp., seemingly intermediate between *L. lethophaga* and precocious forms of *L. tridentata*; SIO 65-144, 176 mm long, in side view; from Willow Creek, tributary to Clear Lake Reservoir, Modoc County, California. D, same specimen, in ventral view of head region, enlarged; with mouth pressed open.

The water was so crystal clear that the bottom seemed to rise ahead. Vegetation comprised patches of *Myriophyllum* and very thick clumps of moss on lava rocks. The bottom in the stream was fine gravel and sand, with scattered lava rocks. The temperature was 11.4° C in the current from a spring and 13.3° C in the river, when the air temperature was 29.4° C. The collection (M34-135) was made by Carl L. Hubbs and family on August 17, 1934, using 4-foot and 6-foot Common Sense woven-meshed seines. One full-grown ammocete and 3 transformed adults came from weeds in the river; one adult was in muddy sand along the bank; the others, all adults, were taken under flat stones lying on clean, coarse gravel in the current from a lateral spring, mostly from under one stone where, when the stone was first turned, they looked like a breeding pod.

The specimens taken at this station are the only ones designated as types. The holotype (UMMZ 130648), 128 mm in total length, is a mature male (Figures 1A–B). The paratypes (UMMZ 130649) comprise one male ammocete 130 mm long, 4 males and 5 females, nearly to quite ripe, 116–142 mm long, and one male that was taken partly decayed, within the same size range. A fully mature female, the smallest specimen, is illustrated (Figures 1C–D).

On the basis of his field work Rutter (1908: 110) described Fall River and the adjacent part of Pit River as follows:

The upper Pitt River, above the mouth of Fall River, was nearly dry in August, 1898. The water it contained was of a slightly milky color. The rocks at the bottom were covered with a spongy slime . . .

At Fall River Mills, Pitt River receives Fall River, a stream about 100 feet wide and 4 feet deep, with a strong current, but only about 15 miles long. Fall River takes its rise in two or three large springs near Dana, and flows several times as much water as Pitt River above their union. The water is clear and cool and the bottom gravelly, making an excellent spawning stream for salmon, but difficult to attain on account of the steep rapid at its mouth, as well as the fall in Pitt River [see map, Figure 3].

Above the mouth of Fall River for a few miles, Pitt River is broad and deep, but without any perceptible current. Below the mouth of Fall River the character changes entirely. It is broad but shallow, very swift, with many rapids, and makes a rapid descent to the falls [3 km southwest of the mouth of Fall River]. Pitt River Falls, which are 65 feet high, are thought by many to rival in beauty any to be seen in Yosemite Valley. The middle portion is a sheer fall, but each side is broken by ledges, so that it is possible in high water for fish to pass. A fish ladder has been blasted out of the rock near the left bank, and salmon now go over the falls in considerable numbers.

The falls do not delimit the distribution of *Lampetra lethophaga* (nor of the endemic *Cottus pitensis* Bailey and Bond, 1963: 20–25, figs. 1d, 3b, 4d) in the Pit River system, but other Pit River endemics, *Catostomus microps* Rutter (1908: 120–121, fig. D), *Cottus asperrimus*, and *C. macrops* do appear to occur only above these falls.

3. Lower Hat Creek, below Highway 299 bridge, over a stretch of about 6 km, above Lake Britton (an artificially ponded section of Pit River), in northeastern Shasta County; altitude ca. 850 m. On October 4, 1968, lampreys by good fortune were taken and preserved during a massive poisoning by the California Department of Fish and Game, for the removal of "rough" fish, presumably in the hope of controlling predation on and competition with the favored gamefish. Dr. Roger A. Barnhart, Leader of the California Cooperative Fishery Unit at Humboldt State College, who participated in the operation, preserved the fine series of specimens that he has made available for the present study. Dr. Barnhart reported (pers. comm., 1970) that "the lamprey turned out to be quite numerous in this section of Hat Creek. . . . We turned up 2–3 brook lampreys in our fall electrofishing census last fall so apparently we did not obtain a complete kill of lamprey" (again by good fortune).

The collection furnished by Dr. Barnhart comprises 2 ammocetes 91 and 144 mm and 107 transformers 134–199 mm long, of which 12 transformers (SIO 71–8) are retained at Scripps Institution. Nine other specimens (2 ammocetes 56 and 91 mm long and 7 transformers 146–178 mm long; CAS 13391) were collected by Leonard O.

Figure 3. Natural lakes and streams of the entire Pit River drainage basin and the upper part of Klamath River system, showing all known Locations, numbered 1-11, for the nonparasitic *Lampetra lethophaga*; also some waters inhabited by parasitic forms of the same subgenus in the Klamath basin. The collection stations for samples of the precocious stocks of *L. tridentata* utilized in this report are shown at A, for Shasta River near junction with Klamath River; B, for Klamath River at Klamathon; and C, for the Copco Lake impoundment of Klamath River. Shown also are nearby waters of contiguous drainage basins. Two of the largest of the many marshes in the area are Klamath Marsh (KM) and Sycan Marsh (SM).

Map based largely on the United States Geological Survey 1:500,000 state maps of Oregon and California and on the following National Topographic Maps of the 1:250,000 series: Medford, Crescent, Klamath Falls, Weed, Alturas, and Susanville (1955-1963). The natural limits of South Klamath Lake, Tule Lake ("Rhett Lake" on some old maps), and Clear Lake (of the Klamath system) and of the seldom attained outlet stage of Goose Lake are taken chiefly from three old one-degree U.S.G.S. topographic sheets 1:250,000: Klamath, Oregon (1894), and Alturas and Modoc Lava-Bed, California (1892). The Map of the Lake Region of Southeastern Oregon by Snyder (1908a) was also used.

THIS PAGE IS LOCKED TO FREE MEMBERS
Purchase full membership to immediately unlock this page

DELVE INTO FANTASY, MAGIC, MYTHOLOGY & FOLKLORE

Forgotten Books'
Full Membership gives
access to 797,885 ancient
and modern, fiction and
non-fiction books.

Continue

*Fair usage policy applies



Figure 4. Spring source of Fall River, in naturally ponded pocket of springs immediately above origin of stream flow (the type locality of *Lampetra lethophaga*); Location 2 on distribution map (Figure 3). Photograph by Laura C. Hubbs, August 17, 1934.

5A. Near Big Bend, collected May 3, 1944 (no further data): 7 ammocetes (CAS 13392), 52–124 mm long; ova developing in largest one.

5B. Between Pit 5 Powerhouse and Pit 5 Dam, collected June – September, 1953 by William Rowley, Brian Curtis, and W. O. Cheney, of California Department of Fish and Game, by electric shocker: 1 ammocete (CAS 25968), 63 mm long (identification presumptive).

LOCATIONS IN KLAMATH RIVER SYSTEM, SOUTHERN OREGON

6. North Fork of Sprague River, in east channel, about 1 km above junction with South Fork (prior to extensive disruption of stream course for irrigation), just east of east boundary of Klamath Indian Reservation, near center of west border of T 36 S, R 14 E, eastern Klamath County (Sprague River joins Williamson River just before that stream enters Upper Klamath Lake); altitude ca. 1340 m. Water moderately clear (bottom visibility about 1 m), shaded by 2-m banks, in pasture; some vegetation in patches; temperature cool; current moderate to swift; width ca. 5–8 m; depth ca. 0.7 m. The collection, M34–120b, by Carl L. Hubbs and family, on August 9, 1934, with 25-foot bag seine, contained one adult male (UMMZ 130573) with maturing testis, with tail 43 mm long (front end missing; estimated original total length about 143mm) and one male ammocete, 91 mm long, secured by much stranding of bottom material. Associated fish species were: *Salmo gairdnerii*, *Catostomus snyderi* Gilbert, *Rhinichthys osculus klamathensis* (Evermann and Meek), *Gila caerulea* (Girard), and *Gila b. bicolor*.

7. Sprague River opposite Ferguson Butte (in narrows of a broad valley), 6.5 km inside Klamath Indian Reservation, in T 36 S, R 13 E, Klamath County; altitude ca. 1325 m. Water moderately clear (bottom visibility ca. 1 m); water buttercup and other plants in dense patches; bottom mostly sandy, becoming dirty in weeds, some gravel, mostly fine, few stones; temperature cool; current mostly slight to moderate; width uniformly ca. 12 m;

depth to 1.2 m. The collection, M34-121, by Carl L. Hubbs and family, on August 10, 1934, with a 6-foot woven-mesh seine, contained a recently transformed male 145 mm long (UMMZ 130576), with testis developing and gut reduced, taken in dense vegetation. Associated species were *Salmo gairdnerii*, *Rhinichthys osculus klamathensis*, *Gila caerulea*, *Gila b. bicolor*, and *Cottus klamathensis* Gilbert.

8. Tributary, near mouth, to upper course of Sycan River (affluent to Sprague River), at Pikes Crossing, 3 km south of Currier Camp, near center of T 33 S, R 15 E, eastern Klamath County; just above a major canyon in river course; altitude ca. 1760 m. Water described as white, very slightly turbid, odorless; some green algae; bottom of sand, coarse gravel, and stones; 23.5° C (air 24.5° C); shore a sage flat, with meadow and timber; current swift in part; nearly 7 m wide in places and to 1.5 m deep. The collection, M 39-18, by Robert Rush Miller and Ralph G. Miller, on June 27, 1939, with 9-foot and 15-foot seines, contained an ammocete (UMMZ 136683) 132 mm long, with small testis, and an adult female 106 mm long, somewhat bobtailed, with nearly ripe ova. Associated species, taken both in tributary and river, were *Salmo gairdnerii* and *Rhinichthys osculus klamathensis*.

9. Sycan River where it enters Sycan Marsh, at ZX Ranch, near center of T 32 S, R 14 E, in western Lake County; altitude ca. 1525 m. Water clear, whitish-brown, odorless; without vegetation; bottom of silt, rocks, and brush, largely scoured; 19.5° C (air 13°); willow thickets along shore, margining meadow; current none to slight; width to 5 m in pools; depth to 0.5 m. The collection, M 39 - 17, by Miller and Miller, on June 26, 1939, with 6-foot and 9-foot seines, contained (UMMZ 136678) an ammocete 121 mm long, with minute gonad, and a female 110 mm long, with large ova. Associated species were *Catostomus snyderi*, *Rhinichthys osculus klamathensis*, and *Gila b. bicolor*.

Dr. Robert Rush Miller was told by personnel at ZX Ranch that the expansive Sycan Marsh (SM, Figure 3) had no open springs and was not known to contain fish. However, it presumably passes fish in high water.

10. This collection, comprising 2 spawning males (Cornell University 10296), 125 and 145 mm long, is labelled "Oregon, 5 mi. W. of Beatty, spring on S. side of road, Apr. 6, 1942, A. H. Wright." This places the station approximately 3-4 km south of midlength of Sprague River, near mid-west border of T 36 S, R 13 E, Klamath County; altitude ca. 1280 m. Dr. Wright stated (in letter of October 1, 1942) that:

In a swampy area near a small streamlet west of Beatty, Oregon, I happened to find two clear, sandy areas about five or six feet deep. The swampy stretch was so treacherous that someone had laid boards across it and as I looked in the clear areas, . . . among the boiling sand were these two lampreys. It was a very striking spring with a very pronounced boiling sandy bottom.

11. Klamath State Fish Hatchery, in the Klamath Indian Reservation, on Crooked Creek, a short spring-fed stream that joins Wood River close to Agency Lake; in Section 6 of T 34 S, R 7½ E, 4 km northerly from

Table 1. Material of *Lampetra lethophaga* of different stages, arranged chronologically by day of collection

Date of Collection	Locality no.	No. of specimens (and length in mm) at each stage		
		Ammocetes	Transformers	Maturing and mature adults ¹
Feb. 16 (1961)	11C	—	—	6(130-160)
Mar. 13 (1970)	11D	—	—	6(132-154)
Mar. 20 (1970)	11E	—	—	1(137)
Apr. 6 (1942)	10	—	—	2(125-145)
May 3 (1944)	5A	7(52-124)	—	—
May 16 (1970)	11F	6(88-191)	—	—
June 2 (1953)	4	—	—	1(155)
June 26 (1939)	9	1(121)	—	<i>1(110)</i>
June 27 (1939)	8	1(132)	—	<i>1(106+)</i>
June-Sept. (1953)	5B	1(63)	—	—
Aug. 9 (1934)	6	1(91)	—	1(ca. 143)
Aug. 10 (1934)	7	—	—	1(145)
Aug. 13 (1934)	11A	34(18-155)	—	—
Aug. 17 (1934)	2	1(130)	—	11(116-142)
August (1949)	11-	4(70-107)	—	—
Sept. 4 (1898)	1	1(105)	1(142)	—
Oct. 4 (1968)	3	4(56-144)	114(134-199)	—
Oct. 20 (1952)	11B	91(37-205)	—	—

¹Maturity indicated by boldface type for nuptial and postnuptial stages; by italic type for very definitely maturing stages, including, for the August 17 type series, some fully mature but not in nuptial color and form; and by roman type single specimens in earlier stages.

Klamath Agency, Klamath County; altitude 1280 m. Water very clear, arising in springs on hatchery grounds, close to upper part of Crooked Creek; with thick clumps of submerged vegetation; bottom of sand and pumice stones, with a little muck mixed with sand in the vegetation; shore grassy with some willows, in meadowland; 7.8° C (hatchery personnel reported virtually no fluctuation); current moderate to, mostly, swift; width of rather straight course 4–8 m; depth to 0.6 m.

This ecological description is based on observations on August 13, 1934, when Carl L. Hubbs and family collected 34 ammocetes (UMMZ 130606), 18–155 mm long, with a 6-foot fine-woven-mesh seine, by vigorously working through thick weed beds, muddy-sand bars, etc. None of the specimens showed any sign of metamorphosis, which may well take place late in this very cold water. The hatchery superintendent (W. I. Howland) provided evidence that “runs of eels” do not occur in this or other local streams, and gave information on the local occurrences of lampreys. Some of the larger ammocetes show some development of ova and of testis. It was therefore concluded, on this initial contact, that the local lampreys are nonparasitic dwarfs.

Associated with the ammocetes in the 1934 collection (M 34–126), in addition to *Salmo gairdnerii* and *Salvelinus fontinalis* (Mitchill) were sculpins, of the Klamath cold-water endemic species *Cottus tenuis* (Evermann and Meek), which was common. The superintendent had 3 or 4 large adults of *Catostomus snyderi*, which he said runs up Wood River and Crooked Creek in early spring. He indicated that still larger suckers, which from his description seemed to be *Chasmistes*, run chiefly up Williamson River, early in the spring, to spawn, and some go up Wood River. Eggs of these large suckers, he said, cover the bottom near wiers across Williamson River to a depth of several inches. When they come, the trout run ceases.

Dr. Carl E. Bond (pers. comm., 1970) has received similar testimony regarding the local lampreys from personnel of the Klamath Hatchery. He has kindly provided me with additional specimens (listed in Table 2 as from Locations 11B–F), taken by and for them at the hatchery, in the ponds and their discharges (“after passing through the ponds, water is channeled into two ditches that run a short distance to Crooked Creek.”). The 13 adults examined in these lots, from Locations 11C–E, are all in nuptial or postnuptial color and form (one, a partly spent male 154 mm long, the largest in 11D, is illustrated as Figure 2A–B). Habitat data for the collection of March 20, 1970 (CEB 70–2; listed in Table 2 as from Location 11E), by Dr. Bond, Mr. Kan, and Richard Wilmot, by “sculpin net (frame net)” are: water clear, with *Ranunculus*, mostly at edges and behind stones; bottom of sand and fine gravel, with few large stones; temperature 6.7° C; shore of masonry or stone; current moderate to slow; width 2.5–5 m; depth to 0.6 m. Lampreys taken in this collection were 2 ammocetes and 4 adults (1 alive and 3 dead), but the one adult received for study is a ripe male 137 mm long.

ZOOGEOGRAPHICAL CONSIDERATIONS

Like most but not all of the nonparasitic forms of lampreys, *L. lethophaga* lives within the range of its assumed parental type (see discussion of Life History, and Hubbs and Potter, in press). So far as known, it is limited to the upper parts of the Pit River system of the Sacramento River drainage in northeastern California and of the Klamath River system, adjoining, in south-central Oregon (Figure 3). This form, and/or parallel-derived nonparasitic types, may yet be discovered elsewhere within the wide range (Figure 5) of *L. tridentata*, but the only nonparasitic lampreys previously known to occur around the North Pacific are the derivatives of *Lampetra (Lampetra) ayresii* (Günther) in the northeastern Pacific drainages (Vladykov and Follett, 1958, 1965), occurring as far south as the Santa

Table 2. Material of *Lampetra lethophaga* from Klamath State Fish Hatchery received from Carl E. Bond and Ting T. Kan

Locality	Date collected	Coll. no. (OS)	Collector	Number (total length, mm)	
				Ammocetes	Nuptial & postnuptial
11B	Oct. 20, 1952	2860	Kenneth Cochrun	25 (77–189) ¹	—
11C	Feb. 16, 1961	2855	Do.	—	6 (130–160)
11D	March 13, 1970	2856	Ore. Game Comm.	—	6 (132–154)
11E	March 20, 1970	2858	Bond, Kan, Wilmot	—	1 (137) ²
11F	May 16, 1970	2859	Bond, Johnson, Kan	6 (88–191)	—

¹Kan measured 66 additional ammocetes, as 37–205 mm in total length, from this collection, which was supposedly taken by electrofishing, and 4, of 70–107 mm, collected at the same hatchery in August, 1949. These measurements have been included in the size-frequency graph (Figure 8).

²Collection sheet lists for this set 2 ammocetes and 4 adults (1 alive and 3 dead).

THIS PAGE IS LOCKED TO FREE MEMBERS
Purchase full membership to immediately unlock this page

FORGOTTEN BOOKS

FULL MEMBERSHIP

797,885 Books!
All you can read
for only
\$8.99/month

Continue

*Fair usage policy applies



initiated the Japanese records of *L. tridentata* by listing a specimen from Yahutugawa (river) in the Okhotsk Sea drainage of Hokkaido. Nemoto (1955: 69–70) stated the range of the species as “the broad region from the Arctic as far south as southern California and down to about 35° N Latitude in the western side of the Northern Pacific,” but gave no supporting documentation for either the Arctic or for the southwestern limit, other than the questionable basis of finding, in the western North Pacific, whales bearing scars showing the tooth marks of *L. tridentata*. Aoyagi (1957), however, reported the capture of a specimen of this species in central Honshu, near 36° N latitude, in Kinugawa (river) at Atsutamura in Tochigi-ken. A further extension of range of the species has now come to light: Dr. O. Okamura has obtained a specimen from Yoshinogawa (river) on Shikoku Island in southern Japan; Tamotsu Iwai (pers. comm., 1970) has verified the identification.

The occurrence of the nonparasitic representative of the *Entosphenus* group in the adjacent basins of the Pit and Klamath rivers is not unique, for these stream systems harbor a number of other endemic fishes, some of which are sympatric with *Lampetra lethophaga*. Klamath endemics were described by Gilbert (1898) and by Evermann and Meek (1898). One of these species, *Catostomus rimiculus* Gilbert (1898: 3) was described from the Klamath River system only but it was later found (Snyder, 1908b: 161) to inhabit also the Rogue River system, which adjoins the Klamath River drainage basin (Figure 3); it may well have crossed over the divide by some fluvial connection. The peculiarities and endemism of the Klamath and Pit river systems were summarized by Hubbs and Miller (1948: 67–71). *Catostomus microps* is a Pit endemic (Rutter, 1908: 120–121) and *Cottus pitensis* Bailey and Bond (1963: 20–24) is known only from drainages of the Pit River and the contiguous Little Sacramento River. An additional indication of residual endemism in the fish fauna of the area under consideration appears to be coming to light: Behnke (1970: 241) has referred to “a group of previously undescribed trout native to several desiccating basins in southern Oregon extending to the Pit and McCloud rivers of northern California.”

DESCRIPTION AND COMPARISONS

The specifications, here adopted, of meristic and morphometric characters, involving definitions and methods, are essentially those proposed by Hubbs and Trautman (1937: 27–43, figs. 1–5). They have been adopted also by Hubbs and Potter (in press) in their account of the distribution, phylogeny, and taxonomy of lampreys.

Chief concern pertains to the designation and to the method of counting of the lingual, oral, and disc teeth, which have been illustrated for *Lampetra (Entosphenus) tridentata* by Hubbs (1947, fig. 3; 1963, fig. 2), by Vladykov and Follett (1958, fig. 1; 1965, fig. 1; 1967, fig. 2), and by Hubbs and Potter (in press, fig. 7). Special points regarding the cusps on the lingual laminae (one transverse and two longitudinal) and on the oral laminae (the supraoral and the infraorbital) are discussed below, in the description of the dentition.

The concept of the circumoral row or series of teeth proposed by Hubbs and Trautman, primarily on the basis of the generalized dentition of *Ichthyomyzon*, seems quite applicable to the *Entosphenus* group, particularly because the posterior circumorals are so definitely aligned with the lateral circumorals, just outside the infraoral lamina. Furthermore, the lateral and posterior circumorals intergrade, through the frequent and unique bicuspid structure, and often through the increasing dilation outward, of one or more of the most lateral and most anterior of the posterior circumorals. Although the alignment of the posterior and lateral elements in a circumoral row is clear, the alignment and method of counting of the anterior connective is complicated by the tendency of all the anterior teeth in this group to alternate (in quincunx), so that a rather arbitrary distinction is involved, as is described below. The alignment and nomenclature of the inner disc teeth

championed by Vladykov and Follett contrasts with the system of Hubbs and Trautman, in that the anterior circumorals are treated as the inner "arterials," the lateral circumorals as the "inner laterals" or "endolaterals," and the posterior circumorals as the inner "posteriors."

Because dentition has traditionally and rightfully been emphasized in the systematics of lampreys, with added stress by Hubbs and Trautman (1937), by Vladykov and Follett (1967), and by Hubbs and Potter (in press), the dental laminae and teeth are here treated first.

DENTITION

Distinctive features of the dentition of *Lampetra lethophaga* outlined in the Diagnosis seem to make clear the relationships as well as the distinctness of this nonparasitic representative of *L. tridentata*. Exhibited are some features of reduction and some of increased variability. Reduction (often a concomitant of dwarfism) is indicated by the frequent degeneration, or loss (Table 3), of the median cusp of the supraoral (the tricuspid supraoral has usually been emphasized — often overemphasized — as the main feature of the genus or subgenus *Entosphenus*); by the occasional reduction of infraoral cusps to 4; by the frequent reduction (Table 4) by 1 cusp on any of the four lateral circumorals, from the normal *Entosphenus* formula of 2-3-3-2 (Figure 7); and by the low number (9-15) of posterior circumorals. The number of cusps in the transverse lingual lamina also seems to be reduced. Furthermore, the teeth tend to be reduced in size; the lingual and oral laminae and, in particular, the lateral circumorals, are all less dilated than in typical *L. tridentata*, and the other teeth tend to be smaller and less robust. Increased variability (commonly associated with degeneration) is shown strikingly by the number of cusps on the supraoral and, less certainly, by the number of infraoral cusps (Table 3), and, definitely, by the number of cusps on the lateral circumorals (Table 4).

The small size of *L. lethophaga* and the weakness of its dentition render cusp counts at times somewhat difficult. Adequate magnification with strong illumination supplemented by a fine jet of compressed air may be called for.

Although the full development of the teeth is a relatively transient feature, the cusps at early stages are sharp. In fact, it is difficult to determine from the teeth, at prime development, whether a specimen represents a parasitic or a nonparasitic form. The lingual laminae atrophy first, in concordance with the elimination of feeding. Of the disc teeth, the outer ones, between the circumorals and the marginals, appear to be the first lost. The degeneration of the anterior circumorals seems to follow soon; they become unrecognizable while the posterior circumorals remain sufficiently developed to be seen. The lateral circumorals are among the last to disappear, or to fragment. Completely spent individuals retain very little of their dentition, and the teeth do not seem to fuse into a cornified mass, as they do in *L. tridentata*.

Lingual laminae.— In correlation with the reduced size of the laminae, the cusps are small — often minute, weak, and crowded. The median tooth of the transverse lamina is usually only weakly to moderately enlarged, and is somewhat variable: it is occasionally partly fused with an adjoining cusp on either side, and is rarely doubled. The transverse lamina is nearly rectilinear, with only the outer ends curved backward. The number of cusps in this lamina is probably reduced, totally only 12-19 in the 11 countable laminae, with a mean of 15.6 (12-17, averaging 14.75 in 8 from Pit River, 19 in two from the Sycan River, and 16 in one from Crooked Creek). The counts for the 15 specimens from the Klamath River near Klamathon are higher, 21-27 (mean 23.3), and the one from Copco Lake has 22. However, the counts for 437 macrophthalmiae of *L. tridentata* from the mouth of Shasta River, not far distant, are intermediate: 14-23 (mean 18.1). McPhail and Lindsey (1970: 57) described the lamina of *L. tridentata* as having "about 15-25 fine

points, the median one scarcely larger than the others.”

The cusps on the longitudinal lamina are also minute and relatively very numerous. They were not counted. McPhail and Lindsey (1970: 53) stated that “*E. tridentatus* has 50–63 fine points on each longitudinal lingual tooth plate, in contrast to 0–26 points in all *Lampetra* species examined,” and they regarded this distinction as one basis for the recognition of *Entosphenus* as a distinct genus. The number of cusps no doubt varies, and the “O” counts presumably represent laminae that have been shed, probably postnuptially. The other basis given for the recognition of *Entosphenus* was the number and arrangement of the velar tentacles — a feature (not checked by me) that hardly seems of generic significance, though seemingly trenchant on the species level.

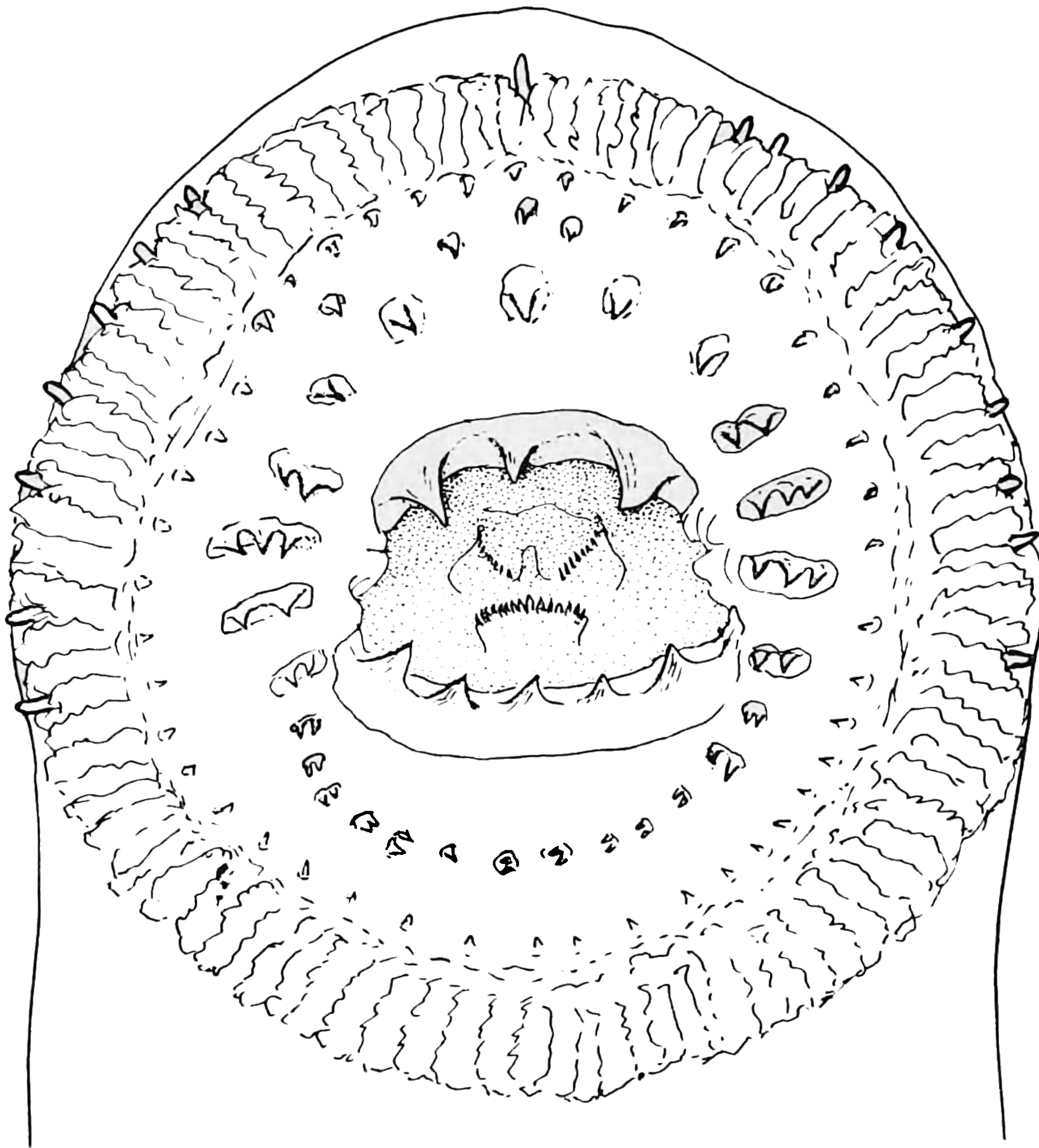

Figure 6. Dentition of *Lampetra lethophaga*, from mature female paratype 116 mm long, shown in Figures 1 C, D; note oral papillae as well as fimbriae; development of bicuspid posterior circumorals is extreme in this specimen.

Oral plates (Table 3).— The oral plates are somewhat more delicate and less dilated than in the parasitic forms of *Entosphenus*.

As noted above, the supraoral plate (or tooth) often fails to exhibit the strongly tricuspid form traditionally used to diagnose *Lampetra tridentata*, for, in each river system, the median tooth is more or less reduced in size, down to a mere rudiment, or is altogether missing. Bicuspids and tricuspids are about equal in frequency, and quadricuspids are occasional. Thus, the supraoral-cusp pattern is much more variable than is usual in *Entosphenus*. Ordinarily, in *L. tridentata*, the tooth is tricuspid, as it is in every one of the 437 macrophthalmiae counted from the mouth of Shasta River, in all 15 adults from the Klamath River, in the one from Copco Lake, and (Mr. Ting T. Kan, pers. comm., 1971) in all 86 adult specimens of the dwarf race from Miller Lake. In *L. lethophaga*, as a further indication of variability, the third cusp is occasionally well to one side of the midline, and

THIS PAGE IS LOCKED TO FREE MEMBERS
Purchase full membership to immediately unlock this page

DELVE INTO FANTASY, MAGIC, MYTHOLOGY & FOLKLORE

Forgotten Books'
Full Membership gives
access to 797,885 ancient
and modern, fiction and
non-fiction books.

Continue

*Fair usage policy applies

Anterior circumorals.— As in *L. tridentata*, the anterior circumorals are typically countable as 5, on the criterion that any anterior tooth is interpreted as a circumoral that approximately reaches or passes behind the imaginary arcuate line passing through the centers of the teeth of the definitely inner-marginal row. The tendency of the anterior oral teeth to alternate so as to approach a quincunx arrangement renders the inclusion or exclusion of a given tooth from the anterior-circumoral series somewhat difficult and rather arbitrary. Another uncertainty is introduced by the tendency for the anterior disc teeth to atrophy rapidly in this species. The counts recorded are 5 for 14 specimens,

Table 3. Counts of cusps on oral plates in *Lampetra lethophaga* and in Klamath River precocious populations of *L. tridentata*

Oral plate	Number of cusps per oral lamina								
	Species	1	2	3	4	5	6	7	Mean
River system (No.) ¹									
Locality (No.) ¹									
Supraoral									
<i>L. lethophaga</i>									
Pit (10)	—	3	5	2 ²	—	—	—	—	2.90
Sprague (5)	—	2	3	—	—	—	—	—	2.60
Crooked (13)	—	8	4	1	—	—	—	—	2.46
Total (28)	—	13	12	3	—	—	—	—	2.64
<i>L. sp.</i>									
Willow (1)	—	—	1	—	—	—	—	—	3.0?
<i>L. tridentata</i>									
Klamath (453)									
Shasta R. (437)	—	—	437	—	—	—	—	—	3.000
Klamathon (15)	—	—	15	—	—	—	—	—	3.00
Copco L. (1)	—	—	1	—	—	—	—	—	3.0?
Infraoral									
<i>L. lethophaga</i>									
Pit (10)	—	—	—	1	9 ²	—	—	—	4.90
Sprague (5)	—	—	—	1	2	1	1	—	5.40
Crooked (13)	—	—	—	1	10	1	1	—	5.15
Total (28)	—	—	—	3	21	2	2	—	5.11
<i>L. sp.</i>									
Willow (1)	—	—	—	—	1	—	—	—	5.0?
<i>L. tridentata</i>									
Klamath (453)									
Shasta R. (437)	—	—	—	—	382	41	14	—	5.158
Klamathon (15)	—	—	—	—	10	5	—	—	5.33
Copco L. (1)	—	—	—	—	—	1	—	—	6.0?

¹Number of specimens.

²Value for holotype.

doubtfully 5 for 7, 6 for 3, and 7 for 2. The anterior circumorals are counted as 5 also in the Willow Creek specimen of doubtful identification.

Lateral circumorals (Table 4).— A striking feature of *L. lethophaga*, already alluded to, is the strong tendency for the number of cusps to decrease by 1 in each of the consistently 4 lateral circumorals, on each side, from the standard, usually almost invariable, formula of 2-3-3-2 in *L. tridentata*. The ratio of reduced counts to the full

Table 4. Counts of cusps on each lateral circumoral tooth, on each side, in *Lampetra lethophaga* from different river systems and in Klamath River precocious populations of *L. tridentata*

Species	River system (No.) ¹ Locality (No.) ¹	Tooth no. ²	Cusps per tooth				Tooth no. ²	Cusps per tooth				Mean
			1	2	3	4		1	2	3	4	
<i>L. lethophaga</i>												
	Pit (20)	—	18 ³	2	—	—	—	9	11 ³	—	—	2.55
	Sprague (10)	4	5	1	—	—	—	5	4	1	—	2.60
	Crooked (22)	4	18	—	—	—	—	18	4	—	—	2.18
	Total (52)	(1)	41	3	—	—	(2)	32	19	1	—	2.40
<i>L. sp.</i>												
	Willow (2)	—	2	—	—	—	—	—	2	—	—	3.0?
<i>L. tridentata</i>												
	Klamath (905-906)	—	874	—	—	—	—	—	873	1	—	3.001
	Shasta R. (874)	—	27	3	—	—	—	—	25	4	—	3.14
	Klamathon (29-30)	—	2	—	—	—	—	—	2	—	—	3.0?
	Copco L. (2)	—	—	—	—	—	—	—	—	—	—	—
<i>L. lethophaga</i>												
	Pit (20)	—	19 ³	1	—	—	—	20 ³	—	—	—	2.00
	Sprague (10)	—	6	4	—	—	—	7	1	—	—	1.90
	Crooked (22)	—	20	2	—	—	—	14	—	—	—	1.64
	Total (52)	(3)	44	8	—	—	(4)	41	1	—	—	1.83
<i>L. sp.</i>												
	Willow (2)	—	—	2	—	—	—	2	—	—	—	2.0?
<i>L. tridentata</i>												
	Klamath (905-906)	—	—	872	2	—	—	855	19	—	—	2.022
	Shasta R. (874)	—	1	21	7	—	—	21	7	2	—	2.37
	Klamathon (29-30)	—	—	2	—	—	—	2	—	—	—	2.0?
	Copco L. (2)	—	—	—	—	—	—	—	—	—	—	—

¹Number of sides counted.

²The teeth are numbered from the anteriormost on each side.

³Value for holotype.

complement, for each of the teeth, counted from the front on each side, for each of the three stream systems, is as follows:

First tooth — 0:20 (Pit), 4:10 (Sprague), 4:22 (Crooked).

Second tooth — 9:20 (Pit), 5:10 (Sprague), 18:22 (Crooked).

Third tooth — 18:20 (Pit), 6:10 (Sprague), 20:22 (Crooked).

Fourth tooth — 0:20 (Pit), 2:10 (Sprague), 8:22 (Crooked).

The Willow Creek specimen agrees with *L. tridentata* in the formula of 2-3-3-2. The same formula, with little variation, holds for the dwarfed, reportedly parasitic Miller Lake lamprey (Carl E. Bond and Ting T. Kan, pers. comm., 1971).

Posterior circumorals (Tables 5, 6).— One of the dentitional features that most clearly points to the derivation of *L. lethophaga* from *L. tridentata* is the frequent bicuspid structure of the more lateral of its posterior circumorals (Figures 6, 7), involving teeth occasionally as far from the end as the seventh (Table 5). *Lampetra tridentata* is the only previously known lamprey of the *Lampetra* type that has such bicuspid teeth in the posterior commissure, and this tendency is notably characteristic of the precocious Klamath River types that may well have been ancestral to *L. lethophaga*. In fact, in those types the

Table 5. Counts of cusps on individual posterior circumoral teeth in *Lampetra lethophaga* and in the Klamath River precocious populations of *L. tridentata*

Species	River system (No.) ¹ Locality (No.) ¹	Tooth No. 1 ² U/B—Mean ³	Tooth No. 2 ² U/B—Mean ³	Tooth No. 3 ² U/B—Mean ³	Tooth No. 4 ² U/B—Mean ³
<i>L. lethophaga</i>					
	Pit (20) ⁴	8/12—1.60	7/13—1.65	14/6—1.30	18/2—1.10
	Sprague (10)	8/2—1.20	8/2—1.20	8/2—1.20	8/2—1.20
	Crooked (18)	17/1—1.06	18/0—1.00	18/0—1.00	18/0—1.00
	Total (48)	33/15—1.31	33/15—1.31	40/8—1.17	44/4—1.08
<i>L. sp.</i>					
	Willow (2)	0/2—2.0?	1/1—1.5?	2/0—1.0?	2/0—1.0?
<i>L. tridentata</i>					
	Klamath (906)				
	Shasta R. (874)	213/661—1.756	549/325—1.372	835/39—1.045	835/39—1.045
	Klamathon (30)	1/29—1.97	1/29—1.97	5/25—1.83	14/16—1.53
	Copco L. (2)	0/2—2.0?	0/2—2.0?	0/2—2.0?	0/2—2.0?
Species	River system (No.) ¹ Locality (No.) ¹	Tooth No. 5 ² U/B—Mean ³	Tooth No. 6 ² U/B—Mean ³	Tooth No. 7 ² U/B—Mean ³	Tooth No. 8 ² U/B—Mean ³
<i>L. lethophaga</i>					
	Pit (20) ⁴	18/2—1.10	19/1—1.05	19/1—1.05	20/0—1.00
	Sprague (10)	10/0—1.00	10/0—1.00	10/0—1.00	10/0—1.00
	Crooked (18)	18/0—1.00	18/0—1.00	18/0—1.00	18/0—1.00
	Total (48)	46/2—1.04	47/1—1.02	47/1—1.02	48/0—1.00
<i>L. sp.</i>					
	Willow (2)	2/0—1.0?	2/0—1.0?	2/0—1.0?	2/0—1.0?
<i>L. tridentata</i>					
	Klamath (906)				
	Shasta R. (874)	872/2—1.002	873/1—1.001	874/0—1.000	874/0—1.000
	Klamathon (30)	25/5—1.17	26/4—1.13	28/2—1.07	29/1—1.03
	Copco L. (2)	0/2—2.0?	0/2—2.0?	1/1—1.5?	0/2—2.0?

¹Number of sides counted (2 per specimen).

²The teeth are numbered from the lateralmost and foremost; the ninth tooth is bicuspid on one side of the one specimen from Copco Lake.

³U/B indicates the number of unicuspid and bicuspid, respectively, for each given tooth number. The numbers (and the means) are in a sense hypothetical, for it is assumed for all teeth more centrad than the fourth on either side that the tooth, unless bicuspid, would have been unicuspid had such a tooth been present: the total number of posterior circumorals may be as low as 9 in *L. lethophaga* and as low as 15 in the Klamath River precocious populations of *L. tridentata*; hence the tooth count on either side often passes beyond the midline into the series from the other side; the tooth number used assumes the arrangement of unicuspid and bicuspid that would have existed, had there been as many as 9 teeth on each side.

⁴The holotype has the outermost 2 teeth on each side bicuspid.

THIS PAGE IS LOCKED TO FREE MEMBERS
Purchase full membership to immediately unlock this page

FORGOTTEN BOOKS

FULL MEMBERSHIP

797,885 Books!
All you can read
for only
\$8.99/month

Continue

*Fair usage policy applies



Table 6 (continued). Counts of posterior circumoral teeth in *Lampetra lethophaga* and in Klamath River precocious populations of *L. tridentata*

Species	Total number of unicuspid posterior circumorals											Mean ³	
	1-2	3-4	5-6 ²	7-8	9-10	11-12	13-14	15-16	17-18	19-20			
<i>L. lethophaga</i>													
River system (No.) ¹													
Locality (No.) ¹													
Pit (10)	1	—	2	1	3	1	2	—	—	—	—	—	8.90
Sprague (5)	—	—	—	1	1	2	1	—	—	—	—	—	10.80
Crooked (8)	—	—	—	—	2	4	2	—	—	—	—	—	11.25
Total (23)	1	—	2	2	6	7	5	—	—	—	—	—	10.73
<i>L. sp.</i>													
Willow (1)	—	—	—	—	—	—	1	—	—	—	—	—	14.0?
<i>L. tridentata</i>													
Klamath (453)													
Shasta R. (437)	—	—	—	—	5	14	94	174	130	20	—	—	15.657
Klamathon (15)	1	—	—	1	4	6	2	1	—	—	—	—	10.60
Copco L. (1)	—	1	—	—	—	—	—	—	—	—	—	—	3.0?

¹Number of specimens.²Value for holotype; the holotype has 6 unicuspid posterior circumorals.³Mean from uncombined data.Table 7. Counts of oral papillae in all available adults of *Lampetra lethophaga*, in the adult of uncertain species from Willow Creek, and in the 14 countable specimens of *L. tridentata* from the Klamath River at Klamathon

	Papillae on each side		Anteromedian papillae		Total papillae	
	<i>lethophaga</i>	Species?	<i>tridentata</i>	Species?	<i>lethophaga</i>	Species?
Number of counts	58	2	30	1	29	1
Range of counts	2-13	6-6	6-12	1	0-2	15
Mean of counts	7.7	6?	8.6	1?	1.03	15?

pertinence), though the counts for the nonparasitic form may be slightly the more variable and slightly the lower on the average, because of some low-count variants.

MYOMERES

The myomeres were counted, as recommended by Hubbs and Trautman (1937: 28), from the first segment that wholly (or almost wholly) lies behind the groove around the last gill-opening, to the one whose lower posterior angle lies in part or wholly above the cloacal slit.

The number, for both ammocetes and adults, has proved to be highly variable in *Lampetra lethophaga*, with a suggestion of some regional diversity, though with a broad overlap. For the three stream systems the counts follow:

Pit River (29 specimens): 63–69; mean $65.62 \pm .31$.

Sprague River (8): 58–66; mean $63.50 \pm .94$.

Crooked Creek (46): 63–73; mean $67.20 \pm .29$.

Bond (1961: 14) gave the number for ammocetes, presumably from Crooked Creek, as about 65–70. Ting T. Kan (pers. comm., 1970) counted 63–69 (mean $65.71 \pm .16$) in 95 ammocetes from Crooked Creek, in part overlapping the specimens I have counted.

These numbers roughly approximate, in mean value, those found for *Lampetra tridentata*, in which, however, there is much regional variation in this character. On the basis of myomere counts Creaser and Hubbs (1922: 6) erroneously separated that species into two subspecies: "*Entosphenus t. tridentatus*" from Unalaska to the Columbia River, with 68 – 74, and "*E. t. ciliatus*," from southern Oregon to southern California, with 57 – 67 myomeres. For a series from Coyote Creek in central California, however, Hubbs (1925: 592) gave the range as 67 – 76, and Hubbs (1967: 307) listed 60 – 70 for 5 specimens from southern California and from off northwestern Baja California. Other, unpublished, counts have mostly approximated 70.

PROPORTIONAL MEASUREMENTS

The proportional measurements (Table 8) of body parts (expressed as permillage of total length) are fairly consistent among the adults referred to *L. lethophaga* from the different stream systems, but are in part somewhat different from the values for the dwarf Klamath River stocks of *L. tridentata*. Outstandingly different is the size of the oral disc, which, as would be expected, is the smaller in the nonparasitic form (36–49 vs. 74–96); the Willow Creek form (of uncertain species) is strikingly intermediate (64). A similar relation, as to be expected, holds for the snout length, though with some overlap. Little difference is indicated for eye length of adults, except that the eye is largest in the Willow Creek specimen. Length over gill-pores seems to average only slightly lower in *L. lethophaga* than in the Klamath precocious stocks of *L. tridentata*; the value for the Willow Creek example is a bit higher than the average for the *L. tridentata* series. Virtually the same relation holds for body depth, again with much overlap. The tail, also with much overlap, averages longer in the *L. lethophaga* than in the *L. tridentata* series, but is distinctly longer in the Willow Creek specimen.

Measurements of ammocetes and transformers as well as adults of *L. lethophaga* indicate some average ontogenetic changes in body proportions. Consistent differences with age and stage, however, are not clearly shown for the tail length. As is usual in lampreys, the body depth increases and the point of greatest depth shifts from near the last gill-slit to just before the origin of the dorsal fin. The distance over the gill-pore series is shorter in the transformers and in the adults than in the ammocetes. The eye, snout, and length over gill-pores appear to average proportionately larger in adults than in transformers.

THIS PAGE IS LOCKED TO FREE MEMBERS
Purchase full membership to immediately unlock this page

DELVE INTO FANTASY, MAGIC, MYTHOLOGY & FOLKLORE

Forgotten Books'
Full Membership gives
access to 797,885 ancient
and modern, fiction and
non-fiction books.

Continue

*Fair usage policy applies

In his key to the lampreys of Oregon, Bond (1961: 14) entered "body rather stout and deep" for *L. lethophaga* (his "*Lampetra* sp."), which would suggest a contrast with *L. tridentata*, though he included no alternative for the parasitic species. He had, I assume, adults of *L. lethophaga* only from Crooked Creek, where the mature specimens exhibit nuptial features, with the body often turgid, whereas in general *L. lethophaga* is much slenderer than the precocious populations of *L. tridentata* in the Klamath River system. Other contrasting characters assigned by Bond presumably reflect the nuptial modifications of *L. lethophaga* in Crooked Creek.

COLOR

Life colors were annotated in the field on maturing to mature adults, comprising the male and female type specimens (UMMZ 130648 and 130649) from Fall River (Location 2), and on one maturing male (UMMZ 130576) from Sprague River opposite Ferguson Butte (Location 7); collected respectively on August 17 and August 10, 1934. Three types taken in vegetation displayed only a trace of the silvery color of macrophthalmiae. They were slaty above to bright brassy-silvery below. The fins were clear waxy-yellow. Of those taken under a stone, the males seemed to approach the silvery color typical of macrophthalmiae more than did the females. The one male from Sprague River, taken in dense vegetation, was deep purplish-brown above the lighter belly, and showed no trace of the silvery phase.

Preserved adults not in full nuptial condition, whether early in development or of stocks that do not attain typical nuptial characters, are dusky purplish over most of the surface, becoming pale yellowish on lower surfaces of head and trunk and on the ventral fin fold behind the anus; the mid-dorsal ridge is weakly lighter; and the second dorsal is dusky on the extreme base only. Specimens in full nuptial development are blackish-purple on the darker areas and on the basal part of both dorsal fins, and the region about the cloaca is conspicuously paler.

The caudal fin in adults is variably darkened, but is generally darkest along the edges of the muscle mass and often lighter near the edge. In high-nuptial adults the caudal area becomes very deeply pigmented, and is almost black along a basal strip, especially on the lower side.

Younger ammocetes are almost uniformly darkened, barely lighter below. The caudal fin is at first largely clear, except in the narrow dark streak margining the muscle mass, about equally above and below. With increasing size the caudal fins grow darker, progressively outward, as the lighter margin becomes narrow. At any stage, however, the paler border varies much in width and intensity, as does the basal dark streak. Occasionally, a submedian dark streak develops on either lobe, and the dark area may be blotched.

Transformers are rather evenly pigmented, and the caudal area is largely dark, with the paler border and the dusky basal streaks varying much in width and intensity. Recently transformed specimens contrast sharply with those of *L. tridentata*, including the precocious Klamath types, in color, in the same way that the macrophthalmiae of *L. fluviatilis* and *L. planeri* differ (Hardisty, Potter, and Sturge, 1970: 385, pl. 1).

At all stages the pigment in the caudal fin area is often marked along the axial line by small dusky blotches, from which close-set and very oblique melanophore files extend across the muscle mass, above and below, margining the myomeres.

All of the color features, and in the stated variation, as described above, were seen in both ammocete and adult stages of the parasitic stocks of the Klamath River system, and elsewhere. Therefore, I fail to confirm any pigmentary differentiation that may be implied in the statements, in the key to Oregon lampreys by Bond (1961: 14), that the ammocetes of the nonparasitic form that he designated "*Lampetra* sp." have "dark pigmentation

outlining tip of tail," and that the larvae of *L. tridentata* have "a dark line above and below tip of tail."

Vladykov (1950, 1960) described in detail sharp pigmentary differences at various ammocete stages between *Lampetra lamottenii* (Leseuer) and *Petromyzon marinus*, but J. R. Nursall and D. G. Buchwald (pers. comm., 1970) have found that *Lampetra lamottenii* in this respect agrees essentially with the closely related parasitic *L. japonica*.

LIFE HISTORY TYPE

An outstanding reason for the interpretation of *Lampetra lethophaga* as a distinct species of the *Entosphenus* complex is its alignment among the nonparasitic lampreys, which have traditionally been accorded specific rank.

It is now recognized that nonparasitic forms have repeatedly evolved from parasitic lampreys. The original discovery, now well analyzed, was that of *Lampetra fluviatilis* (Linnaeus) and *L. planeri* (Bloch), and a parallel case involving Pacific forms of the subgenus *Lampetra* has been documented (Vladykov and Follett, 1965). A few parasitic/nonparasitic pairs were implicit in the revision of northern lampreys by Creaser and Hubbs (1922) and the repeated origin of nonparasitic forms from parasitic ones was definitely indicated by Hubbs (1925) for northern lampreys in general and by Hubbs and Trautman (1937) for three separate lines within the genus *Ichthyomyzon*, one of which had been treated earlier (Reighard and Cummins, 1916); the dual origin of nonparasitic forms from one parasitic species in this genus was indicated by Raney (1952). The speciation aspect of the repeated origin of nonparasitism in lampreys was mentioned by Hubbs (1940: 203; 1941: 188 – 189). Other authors, in particular Zanandrea (1951 – 1962) treated and expanded on the problem of "paired species of lampreys." Alvarez del Villar (1966) discovered the nonparasitic *Tetrapleurodon* of Mexico, and Potter (1968, 1970; Potter, Lanzing, and Strahan, 1968; Potter and Strahan, 1968) described, as a full species, the nonparasitic form of the Southern Hemisphere genus *Mordacia*. Hardisty (1963, 1969) and others have also dealt with this problem. The systematic status and frequency of the "paired species" is being discussed by Hubbs and Potter (in press) and the biological interrelations are being treated by Hardisty, Potter, and Sturge (in press).

Lampetra lethophaga parallels the other nonparasitic lampreys in the rapid maturing of the gonads, which attain full maturity soon after metamorphosis. No difficulty is experienced in sexing either transformers or early-stage adults. As usual in fishes the testis at comparable early stages can be distinguished from the ovary by the circumstance that it is a slenderer, thinner, whiter, and more opaque band. The testis of this lamprey was observed to become markedly lobular as it rapidly enlarges during metamorphosis. The penis at full maturity remains small (Figure 2A). In the holotype, the penis does not extrude.

When *Lampetra lethophaga* was first encountered in August, 1934, and for a long time thereafter, no doubt was felt regarding its interpretation as a nonparasitic species, the first to be recognized in *Entosphenus*. The discovery of the Miller Lake lamprey, a reportedly even more dwarfed yet parasitic form of the same complex, however, has called for a more thorough appraisal of the evidence for the elimination of feeding by the adults of *L. lethophaga*.

Not one of the considerable series of adults of *L. lethophaga*, taken throughout much of the year (Table 1) and representing a full range of stages in maturity was found to contain any food in the gut. A few had the intestinal wall darkened by apparent hemorrhage and a few had lumps of some material in the gut, but these appeared to be cysts and indeed one when opened discharged a larval nematode. Nor did any of the 114 transformers from Hat Creek (Location 3), collected on October 4, 1968, show signs of

having eaten.

Ammocetes longer than about 100 mm, taken May 3–16, June 26–27, August 13–17, September 4, and October 4–20, showed that early stages in the maturing of the gonads are represented through this long period (Table 1). Transformers, taken on September 4 (one specimen) and on October 4 (114) show that the gonads undergo further maturing in that stage: the ova in many of these specimens, even before the elaboration and cornification of the teeth, were estimated, by visual inspection, to be from one-fourth to one-half full size, and to be far fewer than in the dwarfed parasitic form of the Klamath system. Bare traces were observed of the postmetamorphic macrophthalmia stage (characterized by much enlarged eyes and silvery color), such as is prominently shown by the parasitic populations of *L. tridentata*, both dwarfed and full-sized. The incipient macrophthalmiae of *L. lethophaga* contrast with the typical macrophthalmiae of *L. tridentata* just as do the corresponding stages of *L. fluviatilis* and *L. planeri*, as well depicted by Hardisty, Potter, and Sturge (1970: 385, pl. 1).

All adults taken from February 16 to August 17 (Table 1) have gonads in various stages from early to full maturity, though they are, with only moderate overlap, smaller than the transformers (Figure 8). The smaller size of the adults presumably resulted from the actual shrinkage that is known to occur in lampreys during transformation, with, in the case of nonparasitic forms, no later resumption of growth. However, the transformers and the adults did not come from the same place.

Pertinent testimony was secured from the personnel of the Klamath State Fish Hatchery on Crooked Creek (Location 11), where several series of this lamprey were collected at various times of the year. On August 13, 1934, the superintendent of the hatchery informed me that considerable numbers of small lampreys about 5 – 8 inches long which are removed from the screens of the hatchery ponds each year about June contain eggs "about the size of whitefish eggs, showing through the belly along almost the entire length of the body." He added that there are definitely no "runs of eels" in this or in other, nearby streams. On February 5, 1945, the late Dr. Paul R. Needham reported (pers. comm.) that the superintendent had not seen any of the lampreys. On recent occasions the hatchery employees have provided Dr. Carl E. Bond (pers. comm., 1970) with corroborative testimony.

Fish management studies on lower Hat Creek (Location 3) have led Dr. Roger A. Barnhart (pers. comm., 1970) to conclude that the lamprey of that stream is a nonparasitic "brook" form. Nor have I found any evidence of parasitic lampreys in the drainage basins of Pit, Sprague, or Sycan rivers, or in Crooked Creek, from which the material of *Lampetra lethophaga* was obtained.

SEX RATIO

By gross examination it was readily feasible to ascertain the sex ratio of ammocetes larger than 90 mm total length and of all transformers, as well as the adults. The sex of some ammocetes and a few of the transformers of earliest stage was not listed until a small piece of the gonad had been teased apart or crushed between slides, so as to distinguish the testicular tubules from early ova. For only two of the 115 transformers examined was any hesitation encountered in the sexing.

For all 187 specimens sexed, of all stages, the females were moderately outnumbered by the males 87:100. The ratio of females per 100 males seems to decrease with the stage of development: from 128 for 23 female and 18 male ammocetes longer than 90 mm, through 79 for 51 female and 64 male transformers, to 72 for 13 female and 18 male adults. The significance of this indicated change in sex ratio, and indeed its validity, call for further study. Marked fluctuations have been indicated for the sex ratio of *Lampetra planeri*

THIS PAGE IS LOCKED TO FREE MEMBERS
Purchase full membership to immediately unlock this page

FORGOTTEN BOOKS

FULL MEMBERSHIP

797,885 Books!
All you can read
for only
\$8.99/month

Continue

*Fair usage policy applies



were maturing at a small size, perhaps particularly as males, and were assuming the nuptial characteristics that may be essentially similar in the two trophic types.

I have found other evidence of the existence in the Klamath River system of a presumably indigenous and landlocked local form (or of forms) intermediate in size between the large sea-run *Lampetra tridentata* and the endemic nonparasitic dwarf, *L. lethophaga*. Indeed, as is indicated below, there is reported to have been, in Miller Lake, an isolated parasitic form at least as small as *L. lethophaga*.

Fifteen maturing adults only 214–274 mm long, no doubt at approximately the maximum size they would have attained, from Klamath River at Klamathon, have been studied. These specimens (SU 28783 and 35555) were collected at a fishery research installation, respectively by E. A. McGregor, in the fall of 1922, and by Charles H. Gilbert (who died in 1928). They are distinctive in the high number of cusps on the teeth. In this respect they resemble a series of 374 specimens in the macrophthalmia (early-transformation) stage taken nearby, on February 24 to April 5, 1931, in Shasta River at its junction with the Klamath, in wiers set across the stream to tally downstream salmon migrants (Brown, 1938). Tooth and cusp counts taken on all specimens of both lots are herein tabulated, along with those of *Lampetra lethophaga* (Tables 3–6) as these lots are taken to represent or to approximate the ancestral form of *L. tridentata* from which the nonparasitic species originated. The counts for these two lots of *L. tridentata* are in fair agreement, with the unexplained exception that the Klamathon series yielded much the higher counts of bicuspid posterior circumoral teeth. This discrepancy seems particularly strange, when it is noted that the two series were taken only about 11 km apart.

Stranger yet are the characters of a single specimen, even more deviant than those of the Klamathon series. It was taken from Copco Lake, only about 18 straight-line kilometers farther upstream, near the Oregon state line. This specimen, CAS 25987, collected by Millard H. Coots, was adhering to the tongue of a sucker, *Catostomus rimiculus*, that had been caught in a gill-net set overnight, June 3–4, 1953. It is a subadult female, with the gut turgid with food and with the enlarging ova too few for the large sea-run type. It is 241 mm long, about as large as the Klamathon specimens, and its permillage measurements are included within the range for the Klamathon series in Table 8, but the dentition is sharply divergent: in particular, the total number of bicuspid posterior circumorals (16) is higher than in any of the 452 other specimens of *L. tridentata* tallied (Table 6), and some other counts are aberrant. The dentition of this specimen is as follows: longitudinal lingual cusps 29 – 29 = 58 (high); anterior lingual cusps 12 + 1 + 13 = 26 (high); supraoral cusps 3 (normal); infraoral cusps 6 (aberrantly high); anterior circumorals 5 (usual); lateral circumorals 2 – 3 – 3 – 2 — 2 – 3 – 3 – 2 (normal); posterior circumorals 19 (very high) with 16 bicuspid (absolutely extreme) and only 3 unicuspid (next to lowest number; the seventh, tenth, and eleventh of the 19 teeth beginning with the anteriormost and foremost on the right side); 2 marginals on each side greatly dilated; total marginals 57; total teeth 104 (high); total cusps 220 (exceptionally high). Oral papillae 12 + 1 + 9 = 22 (high).

The differences between the lampreys comprising the Shasta River, Klamathon, and Copco Lake series exemplify the tendency toward high local variability of resident lampreys, on a mosaic pattern. Small wonder that *Lampetra lethophaga* displays some local differences.

Additional material of the “praecox” type of *L. tridentata* from the Klamath River and other systems, particularly from Goose and Klamath lakes, are currently under study by Dr. Carl E. Bond of Oregon State College and his graduate student Ting T. Kan. More or less comparable precociously spawning forms now referable to *L. tridentata* have come to my attention from southern California (Hubbs, 1967) and northward to Vancouver Island,

British Columbia. Dwarf, nonmigratory races have been discussed by McPhail and Lindsey (1970: 58–59). There appear to be numerous forms that seem to be comparable to the races of salmon of diverse and distinctive size at maturity (in each case just before reproduction and death).

Limited material at hand from the drainage basins of Clear Lake and of Lost River, in the Klamath system, may bear on the problem of possible intergradation of parasitic and nonparasitic representatives of the *Entosphenus* group. This is particularly true of a single specimen, a postnuptial male only 176 mm in total length (SIO 65 – 144) that was collected by William Johnson and Edward J. O'Neill on May 13, 1965 in Willow Creek, tributary to Clear Lake, Modoc County, California. Originally, as shown on the one-degree 1:250,000 U.S.G.S. Modoc Lava-Bed Sheet of 1892, and on the accompanying distribution map (Figure 3), Willow Creek was the upper, southern headwater of Lost River, of the Klamath River upstream complex, but with an intermittent, presumably flood inflow into Clear Lake. Currently, the flow is directed into this lake, which thus has been enlarged as a reservoir. This specimen was first regarded as referable to *Lampetra lethophaga*, then was thought to represent, more likely, a greatly dwarfed parasitic race. A third possibility, suggested by some recent testimony, is that the specimen in question is merely an exceptionally dwarfed example of a moderately dwarfed resident population. Mr. O'Neill has informed me (pers. comm., 1971) that a number of lampreys 10–12 inches long have been taken adhering to crappies (*Pomoxis* sp.) in Willow Creek, and that many of the "rough fish" of this stream have shown lamprey scars.

Neither by tooth and cusp counts (entered on Tables 3–6 in the row labelled "*L. sp.*"), nor by other characters, have I found it feasible to decide to which of these possibilities this Willow Creek fish can be assigned. In general, such postnuptial specimens are often difficult to refer to trophic type. On comparison with *L. lethophaga* and the precocious Klamath forms of *L. tridentata* this particular specimen is conspicuously intermediate in several respects, as follows:

The Willow Creek specimen (Figures 2 C, D) is definitely smaller than any known mature parasitic adult from the Klamath River system, or elsewhere (other than the representatives mentioned below of the tiny parasitic form of Miller Lake, a disjunct part of the Klamath basin); yet is 16 mm longer than the largest transformed adult at hand of *L. lethophaga* (Figure 8). It is 23 mm shorter than the largest specimen in transformation, but lampreys shrink considerably during and just after metamorphosis.

Particularly notable for the trophic indication is the measurement of the buccal disc (Table 8), which is intermediate, without overlap: 64 thousandths of the total length, vs. 36 – 58 (mean 47) for *L. lethophaga* and 74 – 96 (81) for the *L. tridentata* series. The correlated snout length is also definitely intermediate, but with slight overlap. Body depth is probably also intermediate, but tail length and eye length are higher than in either type under comparison, and length over gill-pores is likely also high (Table 8).

The regular formulae for the cusps on the two oral teeth (supraoral 3 and infraoral 5) and for the four lateral circumorals of either side (2 – 3 – 3 – 2) tend to align the Willow Creek specimen with the parasitic type (Tables 3, 4). Furthermore, the teeth are rather less degenerate than in breeding examples of *L. lethophaga*, and the median cusp on the supraoral is relatively large and sharp, instead of being reduced or absent as it usually is in the nonparasitic form. The total count of posterior circumoral teeth, however, seems intermediate: 2 higher than any count for *L. lethophaga* and on the low side for the parasitic lampreys from Klamath River (Table 6).

The general appearance of the Willow Creek specimen approximates that of the mature adults of *L. lethophaga* from Crooked Creek, so much so as to suggest consanguinity: in each the color is dark, the entire face is strongly turgid, the whole form is robust, the

dorsal fins are much expanded and in contact, and their edges are minutely frayed. However, the similarities may largely reflect a similar stage in sexual development.

In conclusion, it does not seem justified to align the Willow Creek specimen with either *L. lethophaga* or with the Klamath River precocious populations of *L. tridentata*. Its general intermediacy, along with some extreme features, indicate it to be a representative of a somewhat distinct local form.

Data possibly bearing on the uncertain status of the Willow Creek lamprey are furnished by two specimens taken on June 24, 1965 by Edward J. O'Neill and James Keith on the Clear Lake National Wildlife Refuge, during banding of White Pelicans. They were among 44 lampreys spewed up by one young pelican. These may have been captured by the parent(s) in Clear Lake (now used as a reservoir and a refuge), but may have come from elsewhere, as White Pelicans sometimes forage many miles from their rookery. Whatever their source, these 2 specimens, although very considerably damaged, seem to represent a stock different from that of the one Willow Creek specimen. They are larger: one not sexable measures about 220 mm in total length and the other, a female with nearly ripe ova, about 240 mm, vs. 176 mm. Permillage proportions, though hardly precise, seem to differ: tail length, 317 and 327 vs. 340; eye length 15 and 17 vs. 24; snout length 73 and 86 vs. 93. Teeth and cusps number: transverse lingual cusps, 12 + 1 + 12 and 12 + 1 + 14 (higher than in *L. lethophaga*); cusps on supraoral 3 and on infraoral 5 in each, as usual; posterior circumorals 16, apparently all unicuspid. Clearly these two specimens seem to represent a dwarfed population of parasitic lamprey, probably similar to the precocious type sampled from the Klamath River near Klamathon and perhaps similar to the form or forms occurring in Shasta River and the Klamath lakes.

The most surprising circumstance bearing on the relationship between *Lampetra lethophaga* and the parasitic forms referred to *L. tridentata* is the discovery by Dr. Carl E. Bond of a parasitic form indicated as even smaller than *L. lethophaga*. This form seems to have been endemic in the small drainage basin (shown on the distribution map, Figure 3) of Miller Lake (named Fish Lake on some old maps), which basin is a disjunct, endorheic unit, ending in a marsh, at the north end of the Klamath drainage system. Dr. Bond has stated (pers. comm., 1971) that:

The evidence for predation in the Miller Lake lamprey is strong. The little beasts prevented the maintenance of a trout fishery in the lake. They would kill trout and tui chub [*Gila bicolor*] and then mine out the soft parts, leaving the perforated skin and the skeleton on the bottom. Spawned-out lampreys were also devoured — even on the spawning beds. Miller Lake is in T 27 S, R 6½ E, Sections 11 – 14 and in a disrupted portion of the Klamath River drainage.

The lamprey is now extinct, a [tragic] victim of a toxaphene operation designed by the Oregon State Commission to eradicate it. I had hoped that it had survived in the outlet, Miller Creek, but no specimens were taken there through extensive and thorough electrofishing by Harry Lorz of the Oregon State Game Commission in 1970, many years after the extinction of the lamprey.

Adults from the spawning beds range from 72 to 129 mm, mostly between 80 and 105 mm. Many of the near-term ammocetes and some of the non-spawning adults are longer than the spawning adults. Some of the lampreys spawned in the very cold creeks that are tributary to Miller Lake, but the major spawning areas were along the lake shore.

I have thought much during the past 15 years about the significance of the Miller Lake lamprey as a transitional form in a progression to nonparasitic habits. The creatures were locked into a system with only the tui chub, if indeed the chub was not planted later, and had adapted to the paucity of food by cutting a year or two off their lives, so that they metamorphosed in the fall and spawned in the spring and summer — feeding fiercely if food were available, but not growing beyond the length of the ammocoetes. Even when the Game Commission planted trout yearly the lampreys did not grow beyond the range I mentioned — although the trout plants were wiped out each winter.

To me, the outstanding attribute of this form is that parasitism was not obligatory and that the population finally consisted of the offspring of ancestors that could feed fiercely if prey were on hand, but apparently could mature and spawn on a starvation diet. I suspect that if any native fish other than the lampreys were in Miller Lake, the populations were kept low by the lampreys — much as in the same

THIS PAGE IS LOCKED TO FREE MEMBERS
Purchase full membership to immediately unlock this page

DELVE INTO FANTASY, MAGIC, MYTHOLOGY & FOLKLORE

Forgotten Books'
Full Membership gives
access to 797,885 ancient
and modern, fiction and
non-fiction books.

Continue

*Fair usage policy applies

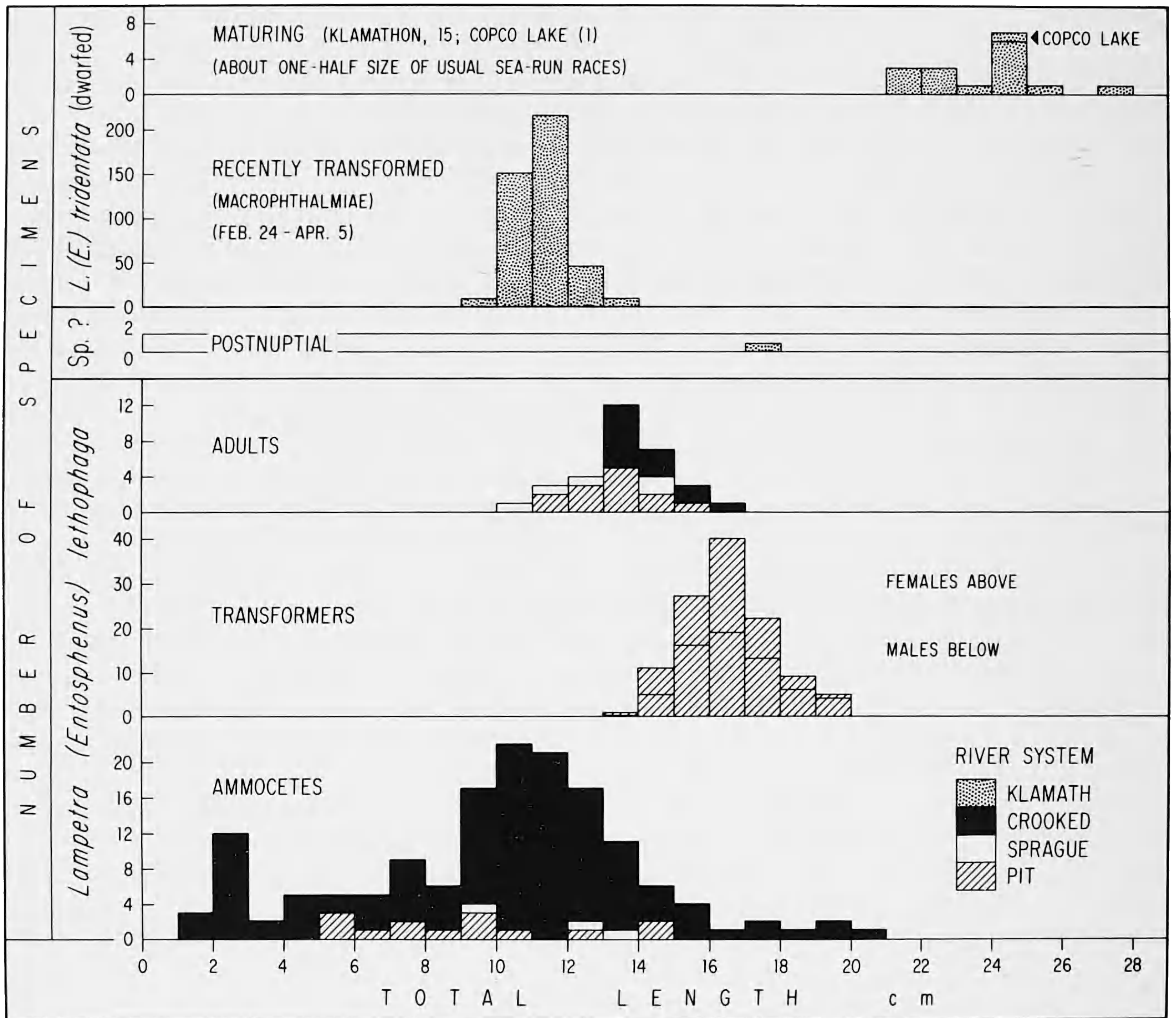

Figure 8. Total-length measurements of all material studied of the nonparasitic *Lampetra lethophaga*, of the specimen (*L. sp.*) of doubtful pertinence from Willow Creek, and of the parasitic, but praecox, form of *L. tridentata*, from Klamath River. The measurements were made to the nearest mm, but are grouped by cm (10–19, 20–29, etc.). Number of specimens shown on ordinate.

Hardisty and Potter (in press).

In concordance with other evidence of size shrinkage during metamorphosis in lampreys, perhaps particularly in nonparasitic species, the modal size of the transformers seems lower than the size of the largest ammocetes, which are the only ones that could be expected to metamorphose. However, the ammocetes and the transformers were not taken at the same locality.

It is probably also significant, and in line with expectation for a nonparasitic lamprey, that the postmetamorphic, maturing and mature adults of *L. lethophaga* are, with little overlap, smaller than the transformers of the same species, but are, to a comparable extent, larger than the recently transformed macrophthalmiae of the lower Shasta Creek population of the parasitic *L. tridentata* (Figure 8). It has been observed for several lampreys that growth during transformation is negative.

It appears (Table 1) either that the time of breeding is unusually variable in *Lampetra lethophaga*, or that full sexual development may be long delayed. Specimens taken in

Crooked Creek (Location 11) and in a spring near Sprague River (Location 10), the only ones exhibiting definite nuptial modification, obviously had spawned, or would have spawned, in late winter or spring, for they were collected from February 16 to April 6 (Table 1). The other adults, at least some seemingly neotenic (see next section), were collected over the summer, from June 2 to August 17. The 11 adult types, taken on August 17 at Location 2, exhibited a wide variation in maturation, thus suggesting prolonged spawning unusually late in the year, or possibly a partial or even complete suspension of sexual development over the next winter. The single adults taken at five locations from June 2 to August 10 also varied widely in degree of maturation, further suggesting prolonged spawning over the summer.

The great difference between the growth patterns of two resident types in the Pit-Klamath area is that *L. lethophaga* almost surely does not grow as adult, whereas the presumably resident, dwarfed forms of *L. tridentata* appear to double their size during their adult, parasitic life — even though they reach only about half the length attained by the larger sea-run populations of *L. tridentata*.

NEOTENY

Lampetra lethophaga exhibits, apparently in some populations only, definite indications of what may be considered as neoteny, other than that of merely reproducing soon after the postammocete metamorphosis.

The only specific reports of neoteny in a lamprey that I have found are by Zanandrea (1956, 1957a, 1958a, 1961) for the nonparasitic *Lampetra zanandreae* Vladykov. (This species is regarded by Hubbs and Potter (in press) as an isolated member, confined to the Po River drainage of Italy, of the subgenus *Lethenteron*, which has hitherto been regarded as restricted to the Arctic Ocean drainage from Europe to North America, to the North Pacific tributaries of Asia, and to northeastern North America.) Zanandrea (1961: 530) found at one locality 12 female ammocetes in an advanced ("third") stage of ovarian development, one of which "showed well-developed principal secondary sexual characters, namely, enlargement of the two dorsal fins, development of the anal pseudo-fin, and the transparent appearance of the body wall, through which the eggs can be seen . . . characters . . . normally associated only with adults that are about to spawn." He obtained at another locality other neotenic female ammocetes, constituting about one-fifth of a series of 221 in the larval stage. He suspected that neoteny in each place may have been induced by tannery pollution, but a test performed to check this suspicion was inconclusive.

The type of neoteny attributed to *L. lethophaga* involves the maturing at some locations of apparently all individuals of both sexes in the prenuptial condition. This is most strikingly shown by the adults from Fall River (the type station, at Location 2). They had passed through the ordinary, prejuvenile metamorphosis (transformation), but although some are in full maturity (witness a female turgid with large ova — Figure 1D), none has developed the ordinary nuptial attributes: melanistic pigmentation and the "principal secondary sexual characters" outlined above in the quotation from Zanandrea. These attributes are seen, well-developed, in 13 adults from Crooked Creek (Figure 2 A, B), in two males from the Sprague River system (Locality 10), in the specimen of uncertain species from Willow Creek (Figure 2 C, D), and in the 15 specimens, in early to late stages of maturing, of the dwarfed parasitic form (referred to *L. tridentata*) from Klamath River at Klamathon. These are the normal attributes of the nuptial stage of lampreys in general, attained at what may be called the second or nuptial metamorphosis. That transformation seems to have been elided at the head of Fall River (type locality of *L. lethophaga*), and is not evident in other specimens from the Pit River system. Series from the Klamath River complex other than at Locations 10 and 11 seem to be developing like the Fall River lot

(maturity in prenuptial appearance). Therefore, the retention or elimination of the normal nuptial metamorphosis does not appear to provide a sound basis for the systematic distinction of nonparasitic lampreys of the Klamath complex from the Pit River form (typical *L. lethophaga*).

The stocks that are neotenic in the sense of developing without the usual nuptial attributes retain to a very large degree, through maturity, the features displayed in the late stages of the ordinary, prejuvenile metamorphosis. The body remains trim and non-turgid, and pale; the dorsal fins remain well separated, with at most a slight connecting ridge, and stay thin and non-turgid, low, and unfrilled at the margin; the other fins stay rather similar; even the anal is generally little enlarged, though moderately enlarged and turgid in the female shown in Figure 1D; the cloacal margins are little swollen; and the preanal fin fold is scarcely enlarged.

The neoteny was notably evident at the type locality (Location 2), where the water was cold (summer readings of 11.4–13.3° C), but the low temperature was presumably not a factor suppressing nuptial development because in Crooked Creek (Location 11), where the nuptial characters are well developed, the water was even colder (7.8° C in August).

REGIONAL DIVERSITY

There is considerable evidence of local diversity in *Lampetra lethophaga* other than the retention or loss of the nuptial metamorphosis, just discussed, but this observed diversity does not seem to warrant specific or subspecific distinction between the populations of the two main stream systems, or between populations within either system. In the analysis of variation the Crooked Creek population is contrasted with the populations sampled from the Sprague (including the Sycan) River system, both in the Klamath complex.

There seems to be some regional difference in the frequency of cusp number on the oral plates (Table 3). Loss of the median supraoral cusp is less frequent in Fall River specimens (the only fully adult ones from the Pit River system) than in those from Crooked Creek, but the few examples from the Sprague River system are intermediate. Some increase in number of infraoral cusps beyond the *Entosphenus* standard of 5 was found in material from Crooked Creek and the Sprague River system, but not in the Fall River specimens.

There appear to be differences between the samples from the three stream systems in the frequency of reduction in cusp number on the four lateral circumorals from the typical *Entosphenus* pattern of 2–3–3–2 (Table 4). The frequency of bicuspid posterior circumorals runs higher in the Pit River sample than in the Crooked Creek specimens, whether tallied by individual teeth numbered from the side (Table 5) or by total number (Table 6), and again the specimens from the Sprague River system seem intermediate.

There may be average differences in number of trunk myomeres: lowest in the Sprague River system, highest in Crooked Creek, intermediate in the Pit River system.

There are some indicated average differences in proportional measurements (Table 8). In the larger ammocetes tail length and length over the gill-pores average longest for the Sprague River specimens, but only 2 are available. Very slight differences among the adults may be related to the expression of nuptial features in 2 of the 5 adults from the Sprague River system and in all 13 adults from Crooked Creek.

The more or less definite indications of local diversity in *Lampetra lethophaga* are consistent with the differentiation, seemingly mosaically arranged, that has been observed among lampreys in general, and among the nonparasitic forms in particular (Hubbs, 1925: 590). Some citations for the genus *Lampetra* are as follows: For subgenus *Entosphenus* — Creaser and Hubbs, 1922: 6, 10 – 11; Hubbs, 1925: 589; 1967. For subgenus *Lethenteron*

THIS PAGE IS LOCKED TO FREE MEMBERS
Purchase full membership to immediately unlock this page

FORGOTTEN BOOKS

FULL MEMBERSHIP

797,885 Books!
All you can read
for only
\$8.99/month

Continue

*Fair usage policy applies



being intermediate in some respects between *L. lethophaga* and the dwarfed parasitic *L. tridentata* of the Klamath River system. Mr. O'Neill also provided dwarfed parasitic specimens from a White Pelican nest on Clear Lake. Dr. Ian C. Potter, of Bath University of Technology, in England, coauthor with me of the revision in press of the lampreys of the world, contributed many ideas and references that have been utilized in the present research. Mr. Howard G. Shirley has been patient and skillful in the final drafting of the distribution maps (Figures 3 and 5) and the graph of length measurements (Figure 8). The late Dr. Albert Hazen Wright of Cornell University, with the cooperation of Dr. Edward C. Raney, made available two fine adult specimens that he collected, along with information on the peculiar habitat.

This paper is a contribution from Scripps Institution of Oceanography, University of California, San Diego.

LITERATURE CITED

- Alvarez del Villar, José
1966. not "1964". Ictiología michoacana, IV: Contribución al conocimiento biológico y sistemático de las lampreas de Jocona, Mich. Anal. Escuela Nac. Ciencias Biol., 13: 107-144, figs. 1-10.
- Aoyagi, Hyoji
1957. General notes on the freshwater fishes of the Japanese Archipelago. Daishukan Shoten, Tokyo: 1-272 +22.
- Applegate, Vernon C.
1950. Natural history of the sea lamprey (*Petromyzon marinus*) in Michigan. U.S. Fish and Wild. Serv.: Spec. Sci. Rept.: Fish., 55: i-xii, 1-237, frontisp., figs. 1-65.
- Bailey, Reeve M., and Carl E. Bond
1963. Four new species of freshwater sculpins, genus *Cottus*, from western North America. Occ. Pap. Mus. Zool. Univ. Michigan, 634: 1-27, figs. 1-4.
- Behnke, Robert J.
1970. The application of cytogenetic and biochemical systematics to phylogenetic problems in the family Salmonidae. Trans. Amer. Fish. Soc., 99 (1): 237-248.
- Berg, L. S.
1931. A review of the lampreys of the northern hemisphere. Ann. Mus. Zool. Acad. Sci. URSS, 32: 87-116, pls. 1-8.
1948. Ryby presnykh vod SSSR i sopredel'nykh stran. Faune SSSR. Akad. Nauk SSSR, 27, 4th ed., vol. 1: 1-466, figs. 1-281. (Translated, 1962.)
1962. Freshwater fishes of the U.S.S.R. and adjacent countries, vol. 1: 1-504 (= 1-465 of 4th ed., 1948+2-p. addenda to 4th ed. + 1317-1325 from vol. 3 of 4th ed.), figs. 1-281. (Translation of 1948 ed.)
- Bond, Carl E.
1961. Keys to Oregon freshwater fishes. Agric. Exp. Sta. Oregon Sta. Univ., Corvallis, Tech. Bull. 58: 1-42, figs. 1-10.
- Brown, Merrill W.
1938. The salmon migration in the Shasta River (1930-1934). California Fish and Game, 24 (1): 60-65, figs. 17-22.
- Churchill, Warren S.
1947. The brook lamprey in the Brule River. Trans. Wisconsin Acad. Sci., Arts and Letters, 37, for 1945: 337-346, charts 1-2.
- Creaser, Charles W., and Carl L. Hubbs
1922. A revision of the Holarctic lampreys. Occ. Pap. Mus. Zool. Univ. Michigan, 120: 1-14, pl. 1.
- Dendy, Jack S., and Donald C. Scott
1953. Distribution, life history, and morphological variations of the southern brook lamprey, *Ichthyomyzon gagei*. Copeia, 1953 (3): 152-162, figs. 1-2, pl. 1.
- Evermann, Barton Warren, and Seth Eugene Meek
1898. A report upon salmon investigations in the Columbia River basin and elsewhere on the Pacific Coast in 1896. Bull. U.S. Fish Comm., 17 (2): 15-84, figs. 1-6, pls. 1-2.

Gilbert, Charles H.

1898. The fishes of the Klamath River basin. Bull. U.S. Fish Comm., 17 (1): 1–13, 6 figs.

Hardisty, M. W.

1944. The life history and growth of the brook lamprey (*Lampetra planeri*). J. Anim. Ecol., 13 (2): 110–122, figs. 1–6.

1951. Duration of the larval stage in the brook lamprey (*Lampetra planeri*). Nature, 167: 38–39, 1 fig.

1954. Sex ratio in spawning populations of *Lampetra planeri*. Nature, 173: 874–875.

1961. The growth of larval lampreys. J. Anim. Ecol., 30: 357–371, figs. 1–5.

1963. Fecundity and speciation in lampreys. Evolution, 17 (1): 17–22.

1969. A comparison of gonadal development in the ammocoetes of the landlocked and anadromous forms of the sea lamprey *Petromyzon marinus*. J. Fish Biol., 1 (2): 153–166, figs. 1–5.

Hardisty, M. W., and I. C. Potter

In press. The behaviour, ecology and growth of larval lampreys. In The biology of lampreys, ed. by M. W. Hardisty and I. C. Potter. Academic Press, London.

Hardisty, M. W., I. C. Potter, and R. Sturge

1970. A comparison of the metamorphosing and macrophthalmia stages of the lampreys *Lampetra fluviatilis* and *L. planeri*. J. Zool., London, 162: 383–400, figs. 1–4.

Heard, William R.

1966. Observations on lampreys in the Naknek River system of southwest Alaska. Copeia, 1966 (2): 332–339, figs. 1–2.

Horn, Edward C., and Joseph R. Bailey

1952. Investigations on the life cycle of the Tennessee brook lamprey. J. Elisha Mitchell Sci. Soc., 68: 144.

Hubbs, Carl L.

1925. The life cycle and growth of lampreys. Pap. Michigan Acad. Sci., Arts and Letters, 4, for 1924: 587–603, figs. 16–22.

1940. Speciation of fishes. Amer. Nat., 74 (752): 198–211 (reprinted in Biological Symposia, ed. by Jaques Cattell, Jaques Cattell Press, Lancaster, Pa., 1941: 7–20).

1941. The relation of hydrological conditions to speciation in fishes. In A Symposium on Hydrobiology, Univ. Wisconsin Press: 182–195.

1947. Cyclostomata or Marsipobranchii. Encyclopaedia Britannica, 6: 921–922B, figs. 1–12.

1963. Cyclostome. Encyclopaedia Britannica, 6: 941–944, figs. 1–6.

1967. Occurrence of the Pacific lamprey, *Entosphenus tridentatus*, off Baja California and in streams of southern California; with remarks on its nomenclature. Trans. San Diego Soc. Nat. Hist., 14 (21): 301–311.

Hubbs, Carl L., and Karl F. Lagler

1958. Fishes of the Great Lakes region. Cranbrook Inst. Sci. Bull. 26: i-xiii, 1–213, frontisp., figs. 1–251, col. pls. 1–44, end-paper map.

1964. Fishes of the Great Lakes region/With a new preface. Univ. Michigan Press, Ann Arbor: i-xv, 1–213, frontisp., figs. 1–251, col. pls. 1–44, end-paper map.

Hubbs, Carl L., and Robert R. Miller

1948. II. The zoological evidence/Correlation between fish distribution and hydrographic history in the desert basins of western United States. In The Great Basin, with emphasis on Glacial and Postglacial times. Bull. Univ. Utah, 38 (20) = (Biol. Ser.) 10 (7): 17–166, figs. 10–29, map 1.

Hubbs, Carl L., and Ian C. Potter

In press. Distribution, phylogeny, and taxonomy. In The biology of lampreys, ed. by M. W. Hardisty and I. C. Potter. Academic Press, London.

Hubbs, Carl L., and Milton B. Trautman

1937. A revision of the lamprey genus *Ichthyomyzon*. Misc. Publ. No. 35, Mus. Zool. Univ. Michigan: 1–109, figs. 1–5, map 1, pls. 1–2.

Ivanova-Berg, M. M.

1931. Über die Lebensdauer der Larve von *Lampetra planeri* aus dem Gebiete des Finnischen Buses. Zool. Anz., 96 (11/12): 330–334, fig. 1.

Jordan, David Starr, and Barton Warren Evermann

1900. The fishes of North and Middle America. Bull. U.S. Nat. Mus., 47, pt. 4: i-ci, 3137–3313, pls. 1–392.

Jordan, David Starr, and Charles Henry Gilbert

1899. The fishes of Bering Sea. In Fur seals and fur-seal islands of the North Pacific Ocean, pt. 3: 433–492, 5 figs., pls. 42–85.

Jordan, David Starr, and Carl Leavitt Hubbs

1925. Record of fishes obtained by David Starr Jordan in Japan, 1922. Mem. Carnegie Mus., 10 (2): 93–348, fig. 1, pls. 5–12.

Knowles, F. G. W.

1941. The duration of larval life in ammocoetes and an attempt to accelerate metamorphosis by injections of an anterior-pituitary extract. Proc. Zool. Soc. London, 111 (=ser. A) 3: 101–109, figs. 1–3, pl. 1.

Leach, W. James

1940. Occurrence and life history of the northern brook lamprey, *Ichthyomyzon fossor*, in Indiana. Copeia, 1940 (1): 21–34, figs. 1–3, pl. 1.

Lindberg, G. U., and M. I. Legeza

1959. Ryby Yaponshogo morya i sopredel'nykh chastei Okhotskogo i Zheltogo morei. Part 1. Amphioxi Petromyzones Myxini Elasmobranchii Holocephali. Akad. Nauk SSSR, Moskva-Leningrad: 1–198, figs. 1–108. (Translated 1967.)

1967. Fishes of the Sea of Japan and the adjacent areas of the Sea of Okhotsk and the Yellow Sea. Part I. Amphioxi Petromyzones Myxini Elasmobranchii Holocephali. Translated by Israeli Program for Scientific Translation, Jerusalem. (Translation of 1959 ed.)

Loman, J. C. C.

1912. Über die Naturgeschichte des Bachneunauges *Lampetra planeri* (Bloch). Zool. Jahrb., Suppl. 15 (1): 243–269, fig. A, pl. 12.

McPhail, J. D., and C. C. Lindsey

1970. Freshwater fishes of northwestern Canada and Alaska. Fish. Res. Bd. Canada Bull. 173: 1–381, illus.

Meek, Alexander

1916. The migrations of fishes. Edward Arnold, London: 1–427, frontisp., figs. 1–128.

Nemoto, Takahisa

1955. White scars on whales / (I) Lamprey marks. Sci. Repts. Whales Res. Inst., no. 10: 69–77, figs. 1–10.

Okada, Yaichiro, and Hyozi Ikeda

1938. Contribution to the study of the freshwater fish fauna of Hokkaido, Japan. Sci. Repts. Tokyo Bunrika Daigaku (Sect. B), no. 55: 133–162, figs. 1–6.

Okkelberg, Peter

1921. The early history of the germ cells in the brook lamprey *Entosphenus appendix* (Gage) up to and including the period of sex differentiation. J. Morph., 35 (1): 1–151, figs. A–D, pls. 1–12.

1922. Notes on the life history of the brook lamprey, *Ichthyomyzon unicolor*. Occ. Pap. Mus. Zool. Univ. Michigan, 125: 1–14, figs. 1–4.

Potter, I. C.

1968. *Mordacia praecox*, n. sp., a nonparasitic lamprey (Petromyzonidae), from New South Wales. Proc. Linn. Soc. New South Wales, 92 (3): 254–261, figs. 1–3, pl. 14.

1970. The life cycles and ecology of Australian lampreys of the genus *Mordacia*. J. Zool., London, 161 (4): 487–511, figs. 1–10, pl. 1.

Potter, I. C., W. J. R. Lanzing, and R. Strahan

1968. Morphometric and meristic studies on populations of Australian lampreys of the genus *Mordacia*. J. Linn. Soc. (Zool.), 47 (313): 533–546, figs. 1–4, pl. 1.

Potter, I. C., and R. Strahan

1968. The taxonomy of the lampreys *Geotria* and *Mordacia* and their distribution in Australia. Proc. Linn. Soc. London, 179 (2): 229–240, pls. 1–2.

Raney, Edward C.

1952. A new lamprey, *Ichthyomyzon hubbsi*, from the upper Tennessee river system. Copeia, 1952 (2): 95–99, pl. 1.

Reighard, Jacob, and Harold Cummins

1916. Description of a new species of lamprey of the genus *Ichthyomyzon*. Occ. Pap. Mus. Zool. Univ. Michigan, 31: 1–12, pls. 1–2.

Rutter, Cloudsley

1908. The fishes of the Sacramento–San Joaquin basin, with a study of their distribution and variation. Bull. U.S. Bur. Fish., 27: 103–152, figs. 1–4, pl. 6.

Schultz, Leonard P.

1930. The life history of *Lampetra planeri* Bloch, with a statistical analysis of the rate of growth of the larva from western Washington. Occ. Pap. Mus. Zool. Univ. Michigan, 221: 1–35, figs. 1–10, pls. 1–2.

THIS PAGE IS LOCKED TO FREE MEMBERS
Purchase full membership to immediately unlock this page

DELVE INTO FANTASY, MAGIC, MYTHOLOGY & FOLKLORE

Forgotten Books'
Full Membership gives
access to 797,885 ancient
and modern, fiction and
non-fiction books.

Continue

*Fair usage policy applies

**RECENT OSTRACODES FROM CLIPPERTON ISLAND
EASTERN TROPICAL PACIFIC**

EDWIN C. ALLISON AND JOHN C. HOLDEN

TRANSACTIONS

**OF THE SAN DIEGO
SOCIETY OF
NATURAL HISTORY**

VOL. 16, NO. 7

14 MAY 1971

THIS PAGE IS LOCKED TO FREE MEMBERS
Purchase full membership to immediately unlock this page

FORGOTTEN BOOKS

FULL MEMBERSHIP

797,885 Books!
All you can read
for only
\$8.99/month

Continue

*Fair usage policy applies



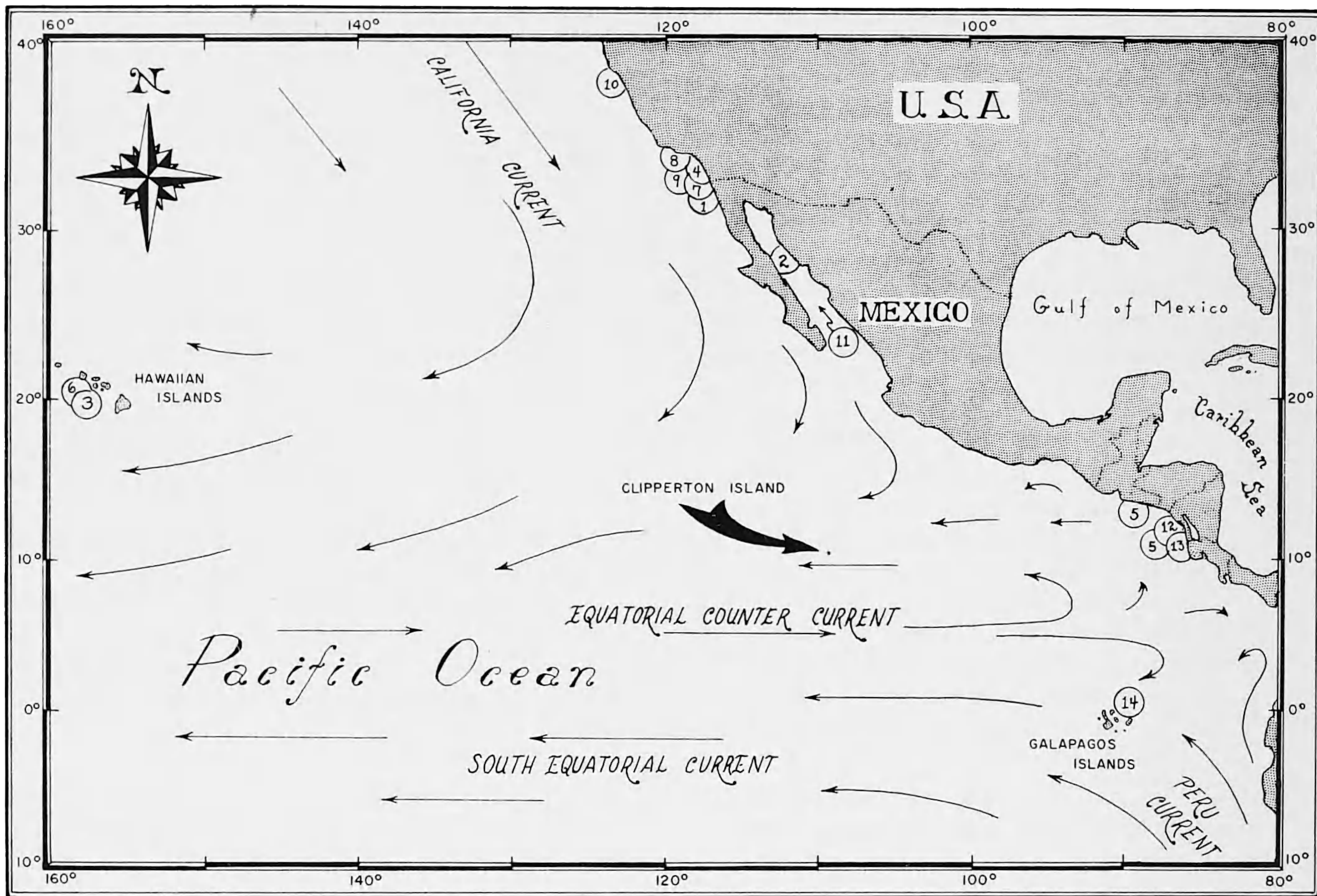

Figure 1. Clipperton Island and adjacent areas. Surface currents for February adapted from Sverdrup, Johnson and Fleming (1942). Previous published works dealing with podocopid and platycopid ostracodes in the east Pacific are numbered within a circle in the approximate area of study. These are (1) Benson, 1959, (2) Benson and Kaesler, 1963 (3) Brady, 1880, (4) Crouch, 1949, (5) Hartmann, 1953, 1957a, 1957b, 1959a, 1959b, (6) Holden, 1967, (7) Juday, 1907, (8) LeRoy, 1943, 1945, (9) Rothwell, 1948a, 1948b, (10) Skogsberg, 1928, 1950, (11) Swain, 1967, (12) Swain and Gilby, 1964, (13) Swain and Gunther, 1969, and (14) Triebel, 1954, 1956, 1957.

landlocked lagoon is fresh and generally palatable above 20 m but abruptly saline and stagnant below that depth (Sachet, 1962c). Early historical accounts of ocean connections (Sachet, 1963; Belcher, 1843) and *in situ* marine fossils, with a 370 ± 100 year radiometric age (Fergusson and Libby, 1962), indicate that the lagoon was at least periodically marine until recently.

The geologic age of Clipperton Island is unknown. But the low incidence of endemism among the marine invertebrates does not support an old age for the faunas.

On the other hand, the strong Caribbean character of the ostracode fauna supports the hypothesis that the Island has maintained a shallow water biota since the early Pliocene. Prior to that time a seaway extending through middle America linking the east Pacific with the Caribbean (Lloyd, 1963) would have allowed the North Atlantic Equatorial Current to sweep from east to west over the Colombian Basin into the Pacific at the latitude of Clipperton Island and could readily account for the Caribbean ostracode species now living there.

The marine invertebrate fauna is an impoverished one in terms of diversity. It is composed principally of central Pacific (Indopacific) and tropical west American (Panamic) species. Many of these species are known to have floating larval stages of long duration or to be potentially subject to dispersal by rafting. Indopacific and Panamic elements are almost equally represented in the inshore faunas, although the ratio of species

representative of these provinces varies somewhat from group to group. Mixtures of Indopacific and Panamic species in the shallow marine faunas of Clipperton Island mark a blending of these two biogeographic provinces which otherwise are clearly distinct (Hertlein and Emerson, 1953; Emerson, 1967). No modern Panamic species is known to have dispersed farther westward than Clipperton Island. A small group of Indopacific species which have crossed the East Pacific Barrier (Hertlein, 1937; Briggs, 1961; Emerson, 1967) is almost completely represented in Clipperton Island faunas, thus suggesting the islands role as a stepping stone. The failure of many other species to effect westward or eastward dispersals once having reached Clipperton Island is one of the great problems presented by that island and its faunas. Shifting Pacific North Equatorial (westward) and Equatorial Counter (eastward) surface currents (Figure 1) as well as subjacent currents, cross the eastern Pacific at the latitude of Clipperton Island, providing possibilities for faunal dispersal in both directions (Wyrтки, 1965; U. S. Navy Hydrographic Office, 1947, 1950, 1966).

The biogeographical importance of Clipperton Island, as well as the attraction of a remote and scarcely known island, inspired brief visits by biologists before 1956. Two expeditions with more ambitious aims were made possible in October-November 1956 and August-September 1958 through the participation of the University of California Scripps Institution of Oceanography in programs of the International Geophysical Year. The research vessel *Spencer F. Baird*, commanded by Captain Alan W. Phinney, provided transportation in both instances. The late Conrad Limbaugh served as scientific party chief for both expeditions. A single dredge haul from a subsequent S.I.O. cruise, locality B-8558, provided the only additional biological materials to which we have had access. Samples and field notes on which the present account of Clipperton Island ostracodes is based are the work of Allison who accompanied both the 1956 and 1958 expeditions. Sediment and algae samples which were the source of the ostracodes dealt with here, were collected by free and SCUBA diving by Allison and Limbaugh except for the dredge sample at station B-8558. The most comprehensive descriptions of the history, geography, geology, and biology of Clipperton Island are to be found in published works of Marie-Hélène Sachet (1960, 1962a, 1962b, 1963), who was one of the participants of the 1958 expedition.

FAUNAL CHARACTERISTICS OF THE OSTRACODA

The marine ostracode fauna of Clipperton Island, like those of the other marine invertebrates there, is impoverished but shows diverse biogeographic affinities. Nine species are described as new and are considered here as endemics. These may, in fact, reflect our poor knowledge of Pacific ostracodes. Areas from which eastern Pacific podocopid ostracodes have been described are shown in Figure 1.

The ostracode samples forming the basis of this account represent freshwater lagoon and various marine reef and off-reef habitats. Species distributions are outlined tentatively on the basis of six samples collected according to field evaluations of physical environmental factors and associated larger organisms. Species abundances, living-nonliving and distributional relationships are shown in Table 1.

Freshwater species. — *Cypridopsis oceanus* sp. nov., *Limnocythere viaticum* sp. nov., and *Potamocypris insularis* sp. nov., are abundant in Clipperton Lagoon. All presumably were introduced within the last 130 years after the last sea connections were blocked and marine conditions were replaced by the existing freshwater (Belcher, 1843). Only the unlikely possibility of prior introduction to, or evolution in, permanent ponds along the rim of the atoll, between the sea and the formerly marine lagoon, could account for a

freshwater ostracode history dating earlier than 130 years ago. It is unlikely that such ponds ever existed on the narrow rimmed atoll. The ostracodes probably were introduced by marine birds which frequent the island during their migratory flights.

Disarticulated valves of several marine species occur in the lagoonal samples and probably represent former marine conditions there. *Bairdia semuvillosa* appears to represent former marine conditions in the lagoon. It does not occur in existing marine habitats around the island, though it is reported living in a wide diversity of west American habitats (Benson, 1959; Swain, 1967) and would appear to tolerate a wide range of conditions.

Water in the lagoon varies in surface salinities from less than 0.1% to greater than 5.0%, depending on seasonal variations in rainfall (Sachet, 1962b). Below about 20 m the water is saline with abundant sulfides and without evidence of an invertebrate fauna.

Marine species. — Known distributions of the ostracodes which occupy the marine habitats give no clear indication of a dominant biogeographic relationship. *Eucytherura binocula*, *Mutilus convergens clippertonensis*, *Paradoxostoma limbaughi*, and *Semicytherura quadraplana* apparently represent an indigenous aspect of the Clipperton Island ostracode faunas.

Five species have Caribbean affinities, *Bairdia* sp., *Triebelina rugosa* (not *T. bradyi* in the sense of Puri, 1960), *Paracytheridea tschoppi*, *Occultocythereis angusta*, and *Cytherelloidea praecipua*. *Paracytheridea tschoppi* first appears in Miocene rocks of Trinidad, and is found living in the Caribbean and tropical eastern Pacific (Panamic province). Species of the genus *Occultocythereis* are common in early Tertiary deposits of North America and Europe (Morkhoven, 1963:197) and now occur in the Mediterranean (Muller, 1894), off the coast of Africa (Brady, 1911), and in the Caribbean. *Occultocythereis angusta* described originally from Madeira Island, northwest Africa (Brady, 1911: "cyther deformis") also occurs in the Caribbean as far back as Miocene (Bold, 1963). Apart from its discovery at Clipperton Island, the genus *Occultocythereis* is unknown elsewhere in the Pacific. *Bairdia* sp. appears closely related to the undescribed Caribbean species *Bairdia* cf. *B. tuberculata* of Puri (1960). *Triebelina rugosa* and *Cytherelloidea praecipua* occur only in the modern Caribbean. *Neocaudites* is likewise a characteristic Caribbean genus (McKenzie, 1967), though we are aware of one species living off Dakar, Africa (unpublished), and two others (one fossil and one Recent) in the Hawaiian Islands (Holden, 1967). The Clipperton form, *N. pacifica pacifica* is considered subspecifically distinct from the living Hawaiian form, *N. p. minima*.

Indopacific and Panamic faunal aspects, clearly evident among associated Clipperton Island marine invertebrates, are weakly represented. *Xestoleberis gracilis*, *Sclerochilus* sp., and *Triebelina serata* may be Indopacific taxa, as might also *Bairdia ritugerd clippertonensis* subsp. nov. The absence of the Loxoconchidae is striking because one or more species of *Loxoconcha* and *Loxoconchella* are commonly represented in island faunas of the Indopacific. *Bairdia semuvillosa*, probably restricted to the extinct marine fauna of Clipperton Lagoon, provides the only evidence of a direct Panamic-Clipperton Island link. *Paracytheridea tschoppi* occurs in the Panamic Province but probably has its origin in the Caribbean.

Pseudocythere caudata is possibly a true cosmopolitan species. Other widely distributed species seem to be restricted to 2 or 3 provinces, as defined by other marine invertebrate groups.

Two species, *Mutilus convergens* and *Paracytheridea tschoppi*, dominate all of the marine samples, accounting for at least 50% of the individuals in each.

Living specimens of *Paradoxostoma limbaughi* and *Sclerochilus* sp. occur only o

THIS PAGE IS LOCKED TO FREE MEMBERS
Purchase full membership to immediately unlock this page

DELVE INTO FANTASY, MAGIC, MYTHOLOGY & FOLKLORE

Forgotten Books'
Full Membership gives
access to 797,885 ancient
and modern, fiction and
non-fiction books.

Continue

*Fair usage policy applies

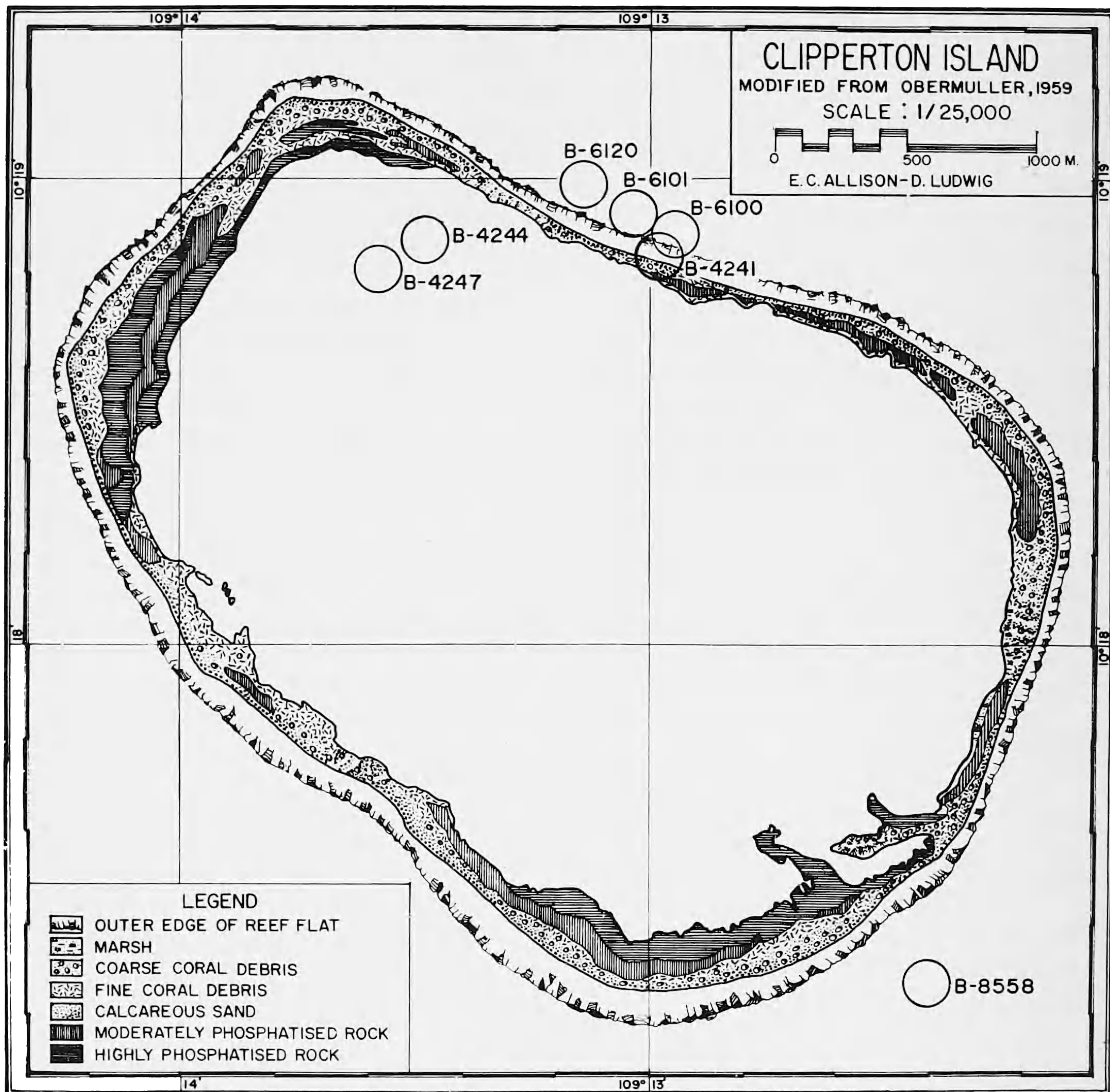

Figure 2. Clipperton Island station locations. Areas within circles indicate approximate station positions.

prominent submarine terrace, northwest of major sandy areas (B-6100); in small sediment pockets between and beneath massive living corals (mostly *Pavona*, *Porites*, and *Pocillopora*) which cover bottom; depth 10-12 m.

B-6120 — Steep slope off north side of island opposite west end of near breach in atoll margin (formed by waves during period between 1956 and 1958 expeditions), below slope break at outer edge of principal submarine terrace; in sediment between blocks of dead coral and sparse cover of living hermatypic coral; depth 40-45 m.

B-8558 — (CARR II 8 D) — Dredged living (ahermatypic) and dead coral debris and calcareous sand from slope off south-eastern side of Clipperton Island (10°19'N, 109°12'W); depth 92 m. Scripps Institution of Oceanography expedition CARROUSEL (R/V *Spencer F. Baird*), 11 August 1964.

SPECIES	SCHEMATIC PHYSIOGR. AND STATIONS						meters
	(B-4244, B-4247) LAGOON	(B-4241) REEF	(B-6100) 6-8 m.	(B-6101) 10-12 m.	(B-6120) 40-45 m.	(B-8558) 92 m.	
<i>Bairdia teeteri</i>	2	12	2	7	53	2	
<i>B. ritugerdia clippertonensis</i>		1		1	10		
<i>B. simuvillosa</i>	7						
<i>B. sp.</i>					2		
<i>Triebelina rugosa</i>					3	1	
<i>T. sertata</i>		2			6		
<i>Macrocyprina vargata</i>				7	148		
<i>Potamocypris insularis</i>	46						
<i>Cypridopsis oceanus</i>	32						
<i>Pontocypris (?) sp.</i>		1			2		
<i>Pseudocythere caudata</i>					1		
<i>Eucytherura binocula</i>					7	3	
<i>Paracytheridea tschoppi</i>		21	62	118	149	9	
<i>Semicytherura quadraplana</i>			5	1	1		
<i>Mutilus convergens clippertonensis</i>	5	250	193	207	321	22	
<i>Limnocythere viaticum</i>	19						
<i>Paradoxostoma limbaughi</i>		13				1	
<i>Sclerochilus sp.</i>		3			5	8	
<i>Neocaudites pacifica pacifica</i>					5	3	
<i>Occultocythereis angusta</i>					2	1	
<i>Xestoleberis gracilis</i>		16		1	3	1	
<i>X. aff. X. eulitoralis</i>					3	1	
" <i>Cythere</i> " cf. " <i>C.</i> " <i>caudata</i>						1	
<i>Cytherelloidea praecipua</i>		5	3	1	25		
TOTAL OSTRACODES	111	323	265	343	742	53	

Table 1. Ostracode species-locality check list. Heavy lines indicate that some or all the individuals contained soft parts and are therefore inferred to have been living at that locality.

Order Podocopida Müller, 1894
 Suborder Podocopina Sars, 1866
 Superfamily Bairdiacea Sars, 1888
 Family Bairdiidae Sars, 1888
 Genus *Bairdia* McCoy, 1844
Bairdia simuvillosa Swain, 1967

Figure 3

Bairdia simuvillosa Swain, 1967:34, pl. 1, figs. 2a-f, 8; text figs. 30c-d, 32, 43a; not *Bairdia simuvillosa*: McKenzie and Swain, 1967:283, pl. 30, fig. 1.

Bairdia sp. aff. *B. verdesensis*: Benson, 1959:42, pl. 1, fig. 6; pl. 8, fig. 16.

Diagnosis.— Elongate *Bairdia*, posteriorly tapered in side view, with straight venter; greatest height in anterior third, greatest width just anterior to midlength; posterodorsum slightly concave up due to brief hump on caudal process.

Description.— In side view: anteroventer evenly rounded; venter straight or slightly concave; posteroventer gently rounded to pointed posterior; posterodorsum slightly convex anterior to brief hump on caudal process; dorsum and anterodorsum almost straight, divided by a rounded anterocardinal angle. Left valve overlapping right valve along all margins except at extreme posterior ventral part of pointed caudal process. In dorsal view: carapace roughly diamond-shaped; greatest width just anterior midlength. Surface of valves smooth, marginal denticles absent, even in younger individuals.

Duplicature moderately wide; anterior and posterior vestibules large. Fused part of duplicature transected by abundant simple radial pore canals, about 50 anteriorly, fewer posteriorly. Normal pores abundant, small, relatively few in center of carapace.

Adductor muscle scars tending to fuse, pattern of an elongate scar above two larger irregular scars which in turn top two smaller oval scars. Dimorphism not observed.

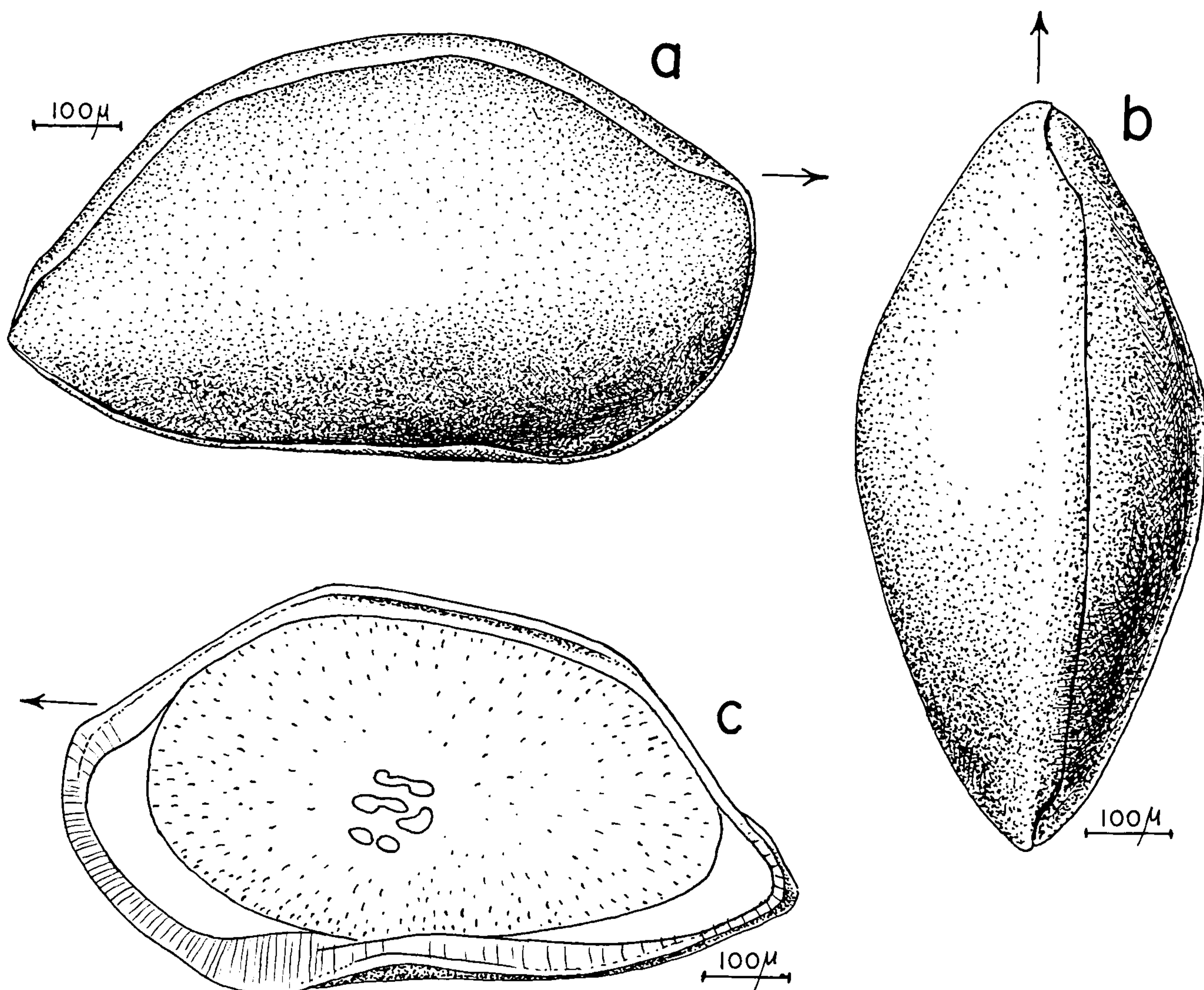

Figure 3. *Bairdia simuvillosa* Swain, 1967. a-b, hypotype, USNM 128066: a, right valve view of adult carapace b, dorsal view of adult carapace. c, hypotype, USNM 128067: interior of adult right valve.

THIS PAGE IS LOCKED TO FREE MEMBERS
Purchase full membership to immediately unlock this page

FORGOTTEN BOOKS

FULL MEMBERSHIP

797,885 Books!
All you can read
for only
\$8.99/month

Continue

*Fair usage policy applies



***Bairdia ritugerda clippertonensis* subsp. nov.**

Figure 4

Diagnosis.— Centrally inflated *Bairdia* with greatest height at anterocardinal angle in anterior third; caudal process humped, slightly pointed at posterior-most part; duplicatures vestibulate; young with posteroventral marginal serrations. Subspecies *B. r. clippertonensis* is smaller (600-750 μ) than *B. ritugerda* sensu stricto; less acuminate posteriorly.

Description.— Carapace small for genus, adult length 600-750 μ ; surface of valves smooth to inconspicuously pitted by large but shallow depressions. In side view: left valve much higher than right valve along dorsum and at inturned area; dorsal margin broadly arched, flattened in anterior third, sometimes flattened at midlength, slightly concave in posterior above humped caudal process; greatest carapace height in anterior third of length; anteroventral margin smooth in adults, serrate in young. In dorsal view: carapace inflated at midlength or just anterior to midlength; posterior and anterior extremities pointed.

Duplicature wide, heavy; narrow vestibules present; straight or bifurcating radial pore canals numerous, up to 50 anteriorly, most false; normal pores small, numerous except around adductor muscle scar area. Eight adductor muscle scars in tight cluster near center of valve.

Dimensions.—

	<i>Length</i>	<i>Height</i>	<i>Width</i>
Holotype, SDNH 04192. Adult left valve, sta. B-6101	595	413	176
Paratype, USNM 128089. Adult left valve, sta. B-6120	759	449	196
Paratype, USNM 128090. Adult right valve, sta. B-6120	755	413	150
Paratype, USNM 128091. Adult right valve, sta. B-6120	680	370	137

Discussion.— The species is much smaller at Clipperton Island than that at Hawaii, where it reaches lengths of 1000 μ and more (Holden 1967: 13). The size difference, together with differences in shape of the carapace distinguish the two populations as separate subspecies.

Its habitat preference is unknown as no living individuals were found. Ten specimens were found off the submerged terrace at 40-45 m, whereas only two specimens were found in shallower water, perhaps indicating a preference for moderately deep water.

***Bairdia teeteri* sp. nov.**

Figures 5, 6

Diagnosis.— *Bairdia* with upturned pointed caudal process; valves heavily pitted; anter and posterolateral surfaces with horizontal ridges giving carapace a terminally blunt aspect as seen from above.

Description.— In side view: venter straight to slightly concave downward, anteroventer and posteroventer about equal in length and convexity; posterodorsum and anterodorsum about equal in length and inclination from horizontal, each slightly concave up dorsum straight to slightly rounded. Left valve strongly over-reaching and over-lapping right valve in dorsal region, with low keel along highest points of dorsum; horizontal anterolateral ridge developed at midheight; horizontal posterolateral ridge extending along pointed, upturned caudal process. Possible sexual dimorphism expressed by relative lower form (σ ?) with height/length ratio = 0.54 compared to (ρ ?) 0.60.

In dorsal views: antermost and postermost parts of horizontal lateral marginal ridges sometimes knob-like giving carapace terminally blunt appearance; centrolateral region inflated, compressed near margins; width/length ratio about 0.40; surfaces densel pitted.

Hinge of "*Bairdiopillata*"-type with small toothlets near posterodorsal and anterodorsal extremities in right valve and corresponding tiny sockets in left valve. Duplicature wide, heavy, traversed by sparse simple radial pore canals numbering about 15 anteriorly and posteriorly, tending to occur in pairs. Vestibules shallow. Adductor muscle scar pattern with eight equant scars — a center scar with seven surrounding it; three smaller mandibular scars just anteroventral to adductor group.

Dimensions.—

	Length	Height	Width
Holotype, USNM 128093. Adult carapace, sta. B-6120	800	483	333
Paratype, SDNH 04193. Adult left valve, sta. B-6101	750	435	190
Paratype, SDNH 04193. Adult right valve, sta. B-6101	749	388	117
Paratype, SDNH 04194. Adult carapace, sta. B-6120	792	461	313
Paratype, SDNH 04195. Adult left valve, sta. B-6101	695	404	165
Paratype, USNM 128092. Penultimate carapace, sta. B-6120	659	367	253
Paratype, SDNH 04196. Penultimate carapace, sta. B-6120	612	345	229

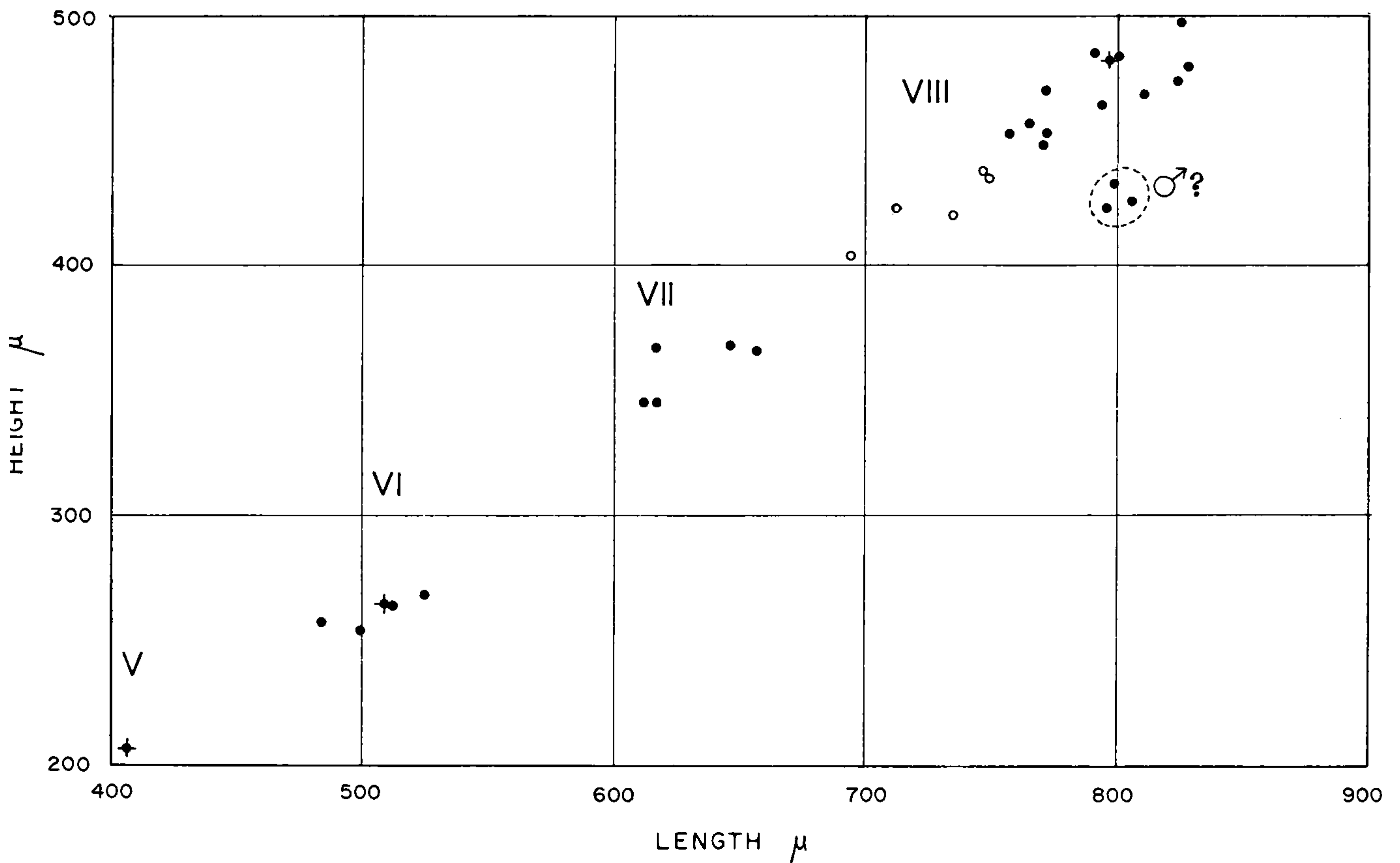

Figure 5. Length-height plot of five growth stages of *Bairdia teeteri* sp. nov. from stations B-6120 (o), B-6101 (o), and B-4241 (o). The group isolated by dashed lines are thought to be males showing higher length-height ratios (Kornicker, 1961). All measurements taken from entire carapaces or the larger left valves.

Discussion.— *Bairdia teeteri* is closely related to *B. attenuata* Brady, 1880, from the Indian Ocean and possibly from off the coast of west Africa (Egger, 1901) in general shape, ornamentation, adductor muscle scar pattern and duplicature. Holden (1967: 14) described the internal features of *B. attenuata* to which the present species can be compared. The important difference between the two species is the presence of horizontal ridges on the antero and posterolateral surfaces of *B. teeteri* which are lacking on *B. attenuata*. The species might be confused with *B. bradyi* Bold, 1957, which has similar ornamentation and somewhat the same shape in side view, but is much wider and diamond shaped in dorsal

view, not laterally compressed as *B. teeteri*. Another species belonging to the *B. attenuata* group and closely related to the present species is *Bairdia* sp. c of Bold (1966) from Coco Solo, Panama. It appears to have a poorly developed horizontal ridge on the posterolateral surface. According to Bold (personal comm.) the species occurs on the Pacific side of Costa Rica in rocks of "Young Neogene" age.

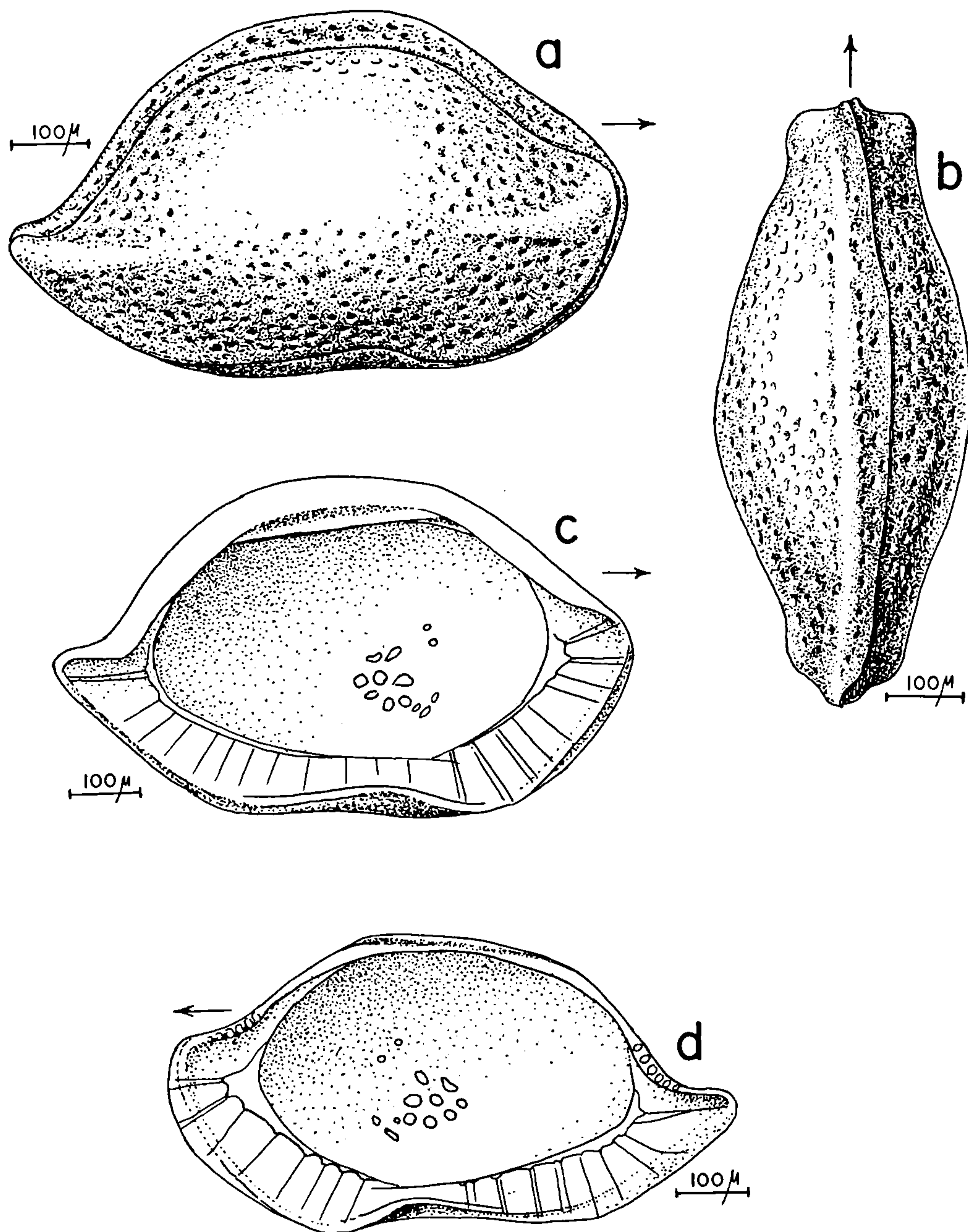

Figure 6. *Bairdia teeteri* sp. nov. a-b, holotype, USNM 128093; a, right valve view of adult carapace; b, dorsal view of entire carapace. c-d, paratype, SDNH 04193; c, interior view of adult left valve, d, interior view of adult right valve.

At Clipperton Island sizes of individuals differ consistently between the stations B-6120 and B-6101 (see text-fig. 5). The adductor muscle scar pattern and the "*Bairdiopilata*"-type dentition seem to be consistent as are other features and size differences apparently are not taxonomically significant.

The species is named for James Wallis Teeter, who in 1966 recognized its uniqueness during a study of British Honduras ostracodes.

THIS PAGE IS LOCKED TO FREE MEMBERS
Purchase full membership to immediately unlock this page

DELVE INTO FANTASY, MAGIC, MYTHOLOGY & FOLKLORE

Forgotten Books'
Full Membership gives
access to 797,885 ancient
and modern, fiction and
non-fiction books.

Continue

*Fair usage policy applies

The species is closely related and possibly conspecific with a Caribbean species listed as *Bairdia* cf. *B. tuberculata* by Puri (1960), but differs primarily by being more elongate and having a higher anterior margin as viewed from the side.

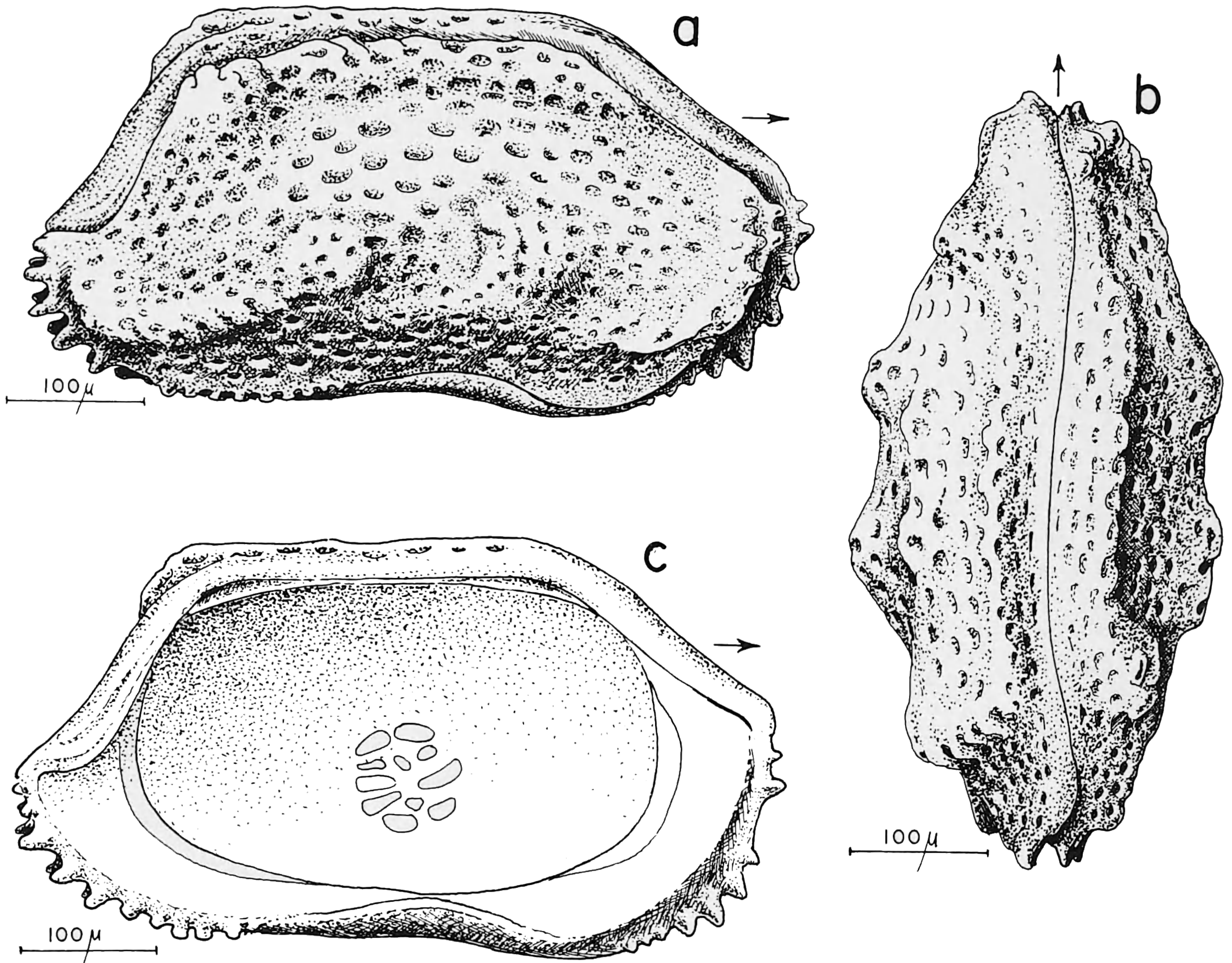

Figure 8. *Triebelina sertata* Triebel, 1948. a-c, hypotype, USNM 128069; a, right valve view of adult carapace; b, dorsal view of adult carapace; c, interior view of adult right valve.

Genus *Triebelina* Bold, 1946

Triebelina sertata Triebel, 1948

Figure 8

Triebelina indopacifica van den Bold, 1946: 74, fig. 7 in part.

Triebelina sertata Triebel, 1948: 29, pl. 19, figs. 1a-b, 2a-d; Key, 1953: 158, pl. 1, fig. 5; Puri, 1960: 132, figs. 3, 4; Guha, 1968: 59, pl. 5, fig. 1.

Triebelina sp. cf. *T. cubensis* Kingma, 1948: 69, pl. 7, fig. 4.

Diagnosis.— Carapace robust, pitted, widest at two large swellings on each valve along midlength; strong dorsal ridge curving downward in posterior part of left valve, confined to dorsum in right valve.

Description.— See Triebel (1948) for a complete description of the species.

Dimensions.

	Length	Height	Width
Hypotype, USNM 128069. Adult left valve, sta. B-6120	572	310	170
Hypotype, USNM 128069. Adult right valve, sta. B-6120	570	283	146

Hypotype, SDNH 04199. Penultimate left valve, sta. B-6120	484	244	142
Hypotype, SDNH 04200. 6th instar, left valve, sta. B-6120	409	213	125

Discussion — *Triebelina sertata* and *T. indopacifica* are closely related (Triebel, 1948). The most conspicuous differences between the two are the lack of swellings in the dorsolateral areas of both valves and the reduction of the long ventrolateral ridge into two broad nodes on each valve along the midlength in *T. sertata*.

According to Key (1953), Bold (1946) had a specimen of what was described as *Triebelina sertata* in his collection of *T. indopacifica* from Ceram, West Indies. Key also noted that the single valve of Kingma's (1948) *Triebelina* cf. *T. cubensis*, from the lower Pliocene of Sumatra, is conspecific to *T. sertata*. One notices that the computed length-height ratio from Kingma's data agrees well with those of other specimens of *T. sertata* but does not agree with his illustrations, which must be distorted.

The species appears to be a shallow water inhabitant. At Clipperton Island it is found from six to 45 meters (none living). One of us (Holden) collected it along beaches at Vanuambalavu, Fiji; Puri found it on reefs in the Florida Keys; and, Triebel reported it from shallow water in the Red Sea. Key's material consisted of one valve each at five stations in the East Indies ranging in depth from 372 to 3221 meters probably representing redeposition.

Triebelina rugosa sp. nov.

Figure 9

Triebelina bradyi: Puri, 1960:132, pl. 6, figs. 7-8,

Diagnosis. — Carapace small, length less than 500μ , relatively elongate, L/H ratio about 2.0, valves nearly equal in height; carapace compressed with parallel sides; lateral surfaces with small prominent tubercles in posterior and anterior lateral areas, two distinct tubercles one above the other beneath posterior cardinal angle.

Description. — In side view: carapace elongate, L/H ratio about 2.0; dorsal margin straight, subparallel with slightly concave downward ventral margin; posterodorsal margin deeply concave upward above serrate caudal process terminating at midheight; anterior margin denticulate beneath flattened anterodorsal margin. Valves unequally ornamented: left valve with more strongly developed short tuberculate vertical posterior ridge than right valve; right valve with two narrow horizontal, sometimes discontinuous, ridges interconnecting anterior lateral tubercles with posterior vertical ridge; both valves tuberculate in anterolateral areas. In dorsal view: carapace compressed, L/W ratio about 2.8; sides flattened, parallel; caudal region compressed behind vertical posterior ridges of right and left valves.

Duplicature wide, heavy, shallow vestibules present with straight, thin radial pore canals. Eight elongate, inclined adductor scars near midheight of valve interior.

<i>Dimensions</i> . —	<i>Length</i>	<i>Height</i>	<i>Width</i>
Holotype, USNM 128094. Adult left valve, sta. B-6120	478	237	167
Holotype, USNM 128094. Adult right valve, sta. B-6120	477	221	167
Paratype, SDNH 04198. Adult carapace, sta. B-6120	466	224	158

Discussion. — The specimens from Clipperton Island are conspecific with a species identified incorrectly as *Triebelina bradyi* by Puri (1960) from the west coast of Florida, and also known to occur in shallow waters of the British Honduran carbonate shelf (Teeter, 1966). This Caribbean-Clipperton species is clearly distinct from the Indopacific *T. bradyi* which is larger (more than 500μ), higher and has a few broad swellings for

ornamentation. *Triebelina bradyi*, in addition, lacks the heavily denticulate, broadly, evenly rounded posteroventral margin of *T. rugosa*.

Triebelina rugosa may have a remote ancestor in *Triebelina* sp/498 of Kollmann (1963) of Triassic (Rhaetic) age from the European Alps. They are strikingly similar in outline and both have ubiquitous elongate pits for ornamentation. They differ in tubercle and swelling arrangement on the lateral surfaces and size of carapace with *T. rugosa* being less than half the size of *T. sp/498*.

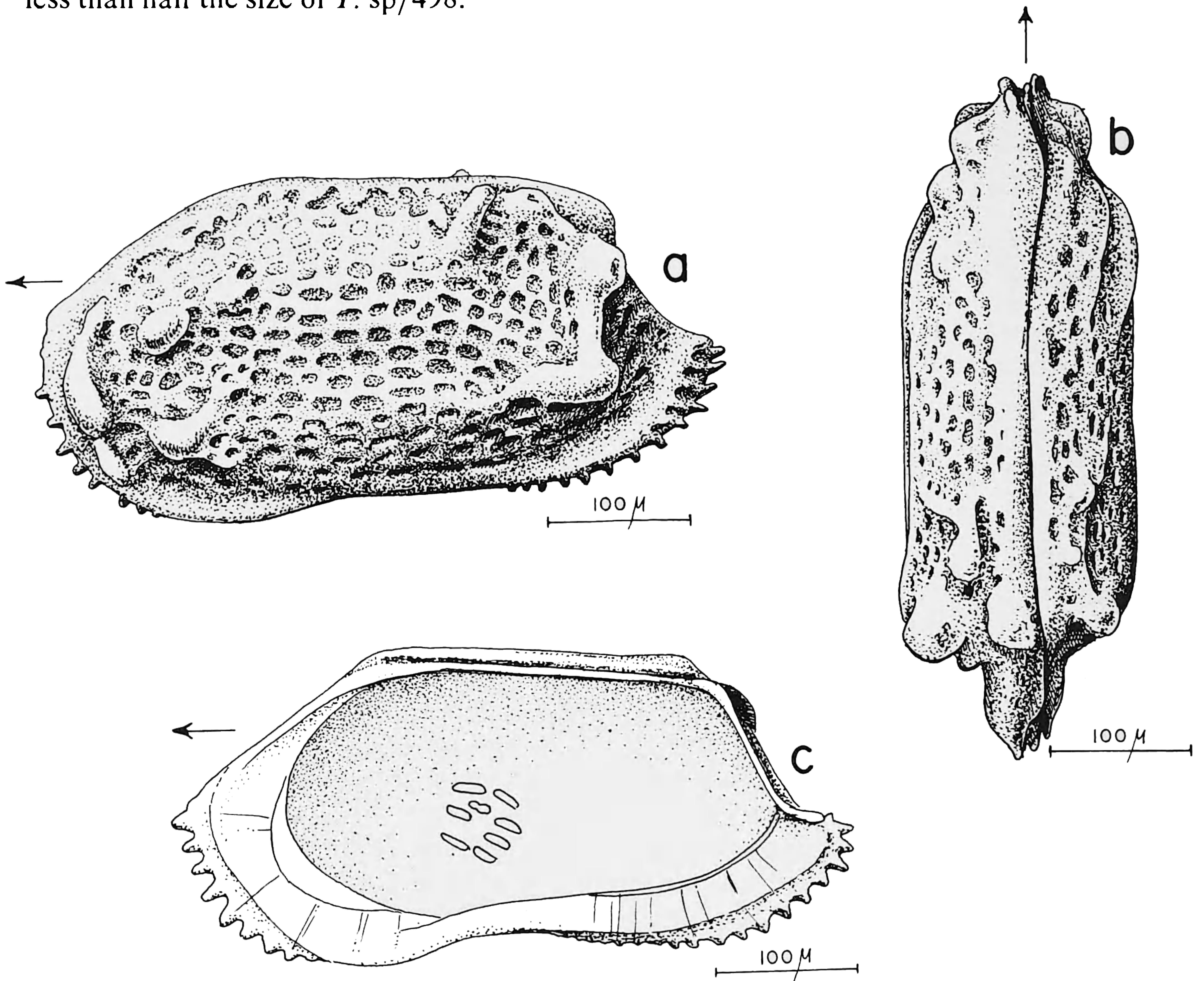

Figure 9. *Triebelina rugosa* sp. nov. a-c, holotype, USNM 128094; a, left valve view of adult carapace; b, dorsal view; c, internal view.

Puri did not give the depth distribution of the species in the Caribbean; however, we presume it is a shallow water form. In the Caribbean it is found at Molasses Reef, off Tavernier, in the Florida Keys (Puri, 1960). At Clipperton Island the species occurs no shallower than 40 meters at station B-6120 on the rubble slope beneath the principal submarine terrace of the island. One valve was found at 92 m at station B-8558.

Superfamily Cypridacea Baird, 1849
 Family Cyprididae Baird, 1849
 Subfamily Macrocypridinae Müller, 1912

THIS PAGE IS LOCKED TO FREE MEMBERS
Purchase full membership to immediately unlock this page

FORGOTTEN BOOKS

FULL MEMBERSHIP

797,885 Books!
All you can read
for only
\$8.99/month

Continue

*Fair usage policy applies



Dimensions. —

	<i>Length</i>	<i>Height</i>	<i>Width</i>
Holotype, USNM 128095. Adult carapace, sta. B-6101	926	410	307
Paratype, USNM 128096. Adult right valve, sta. B-6101	919	420	316
Paratype, USNM 128096. Adult left valve, sta. B-6101	925	422	316
Paratype, SDNH 04201. Penultimate carapace, sta. B-6120	798	360	254
Paratype, USNM 128097. Penultimate carapace, sta. B-6120	821	354	260
Paratype, SDNH 04202. Adult carapace, sta. B-6120	937	430	314
Paratype, USNM 128098. 6th instar carapace, sta. B-6120	550	225	179
Paratype, SDNH 04203. 6th instar carapace, sta. B-6120	538	229	194

Discussion.— The type species of the genus, *Macrocyprina propinqua* Triebel (1960) has a more evenly rounded dorsum, is more terminally pointed in dorsal view, and is slightly larger (950-1008 μ) than the Clipperton species. The color pattern is similar, though of

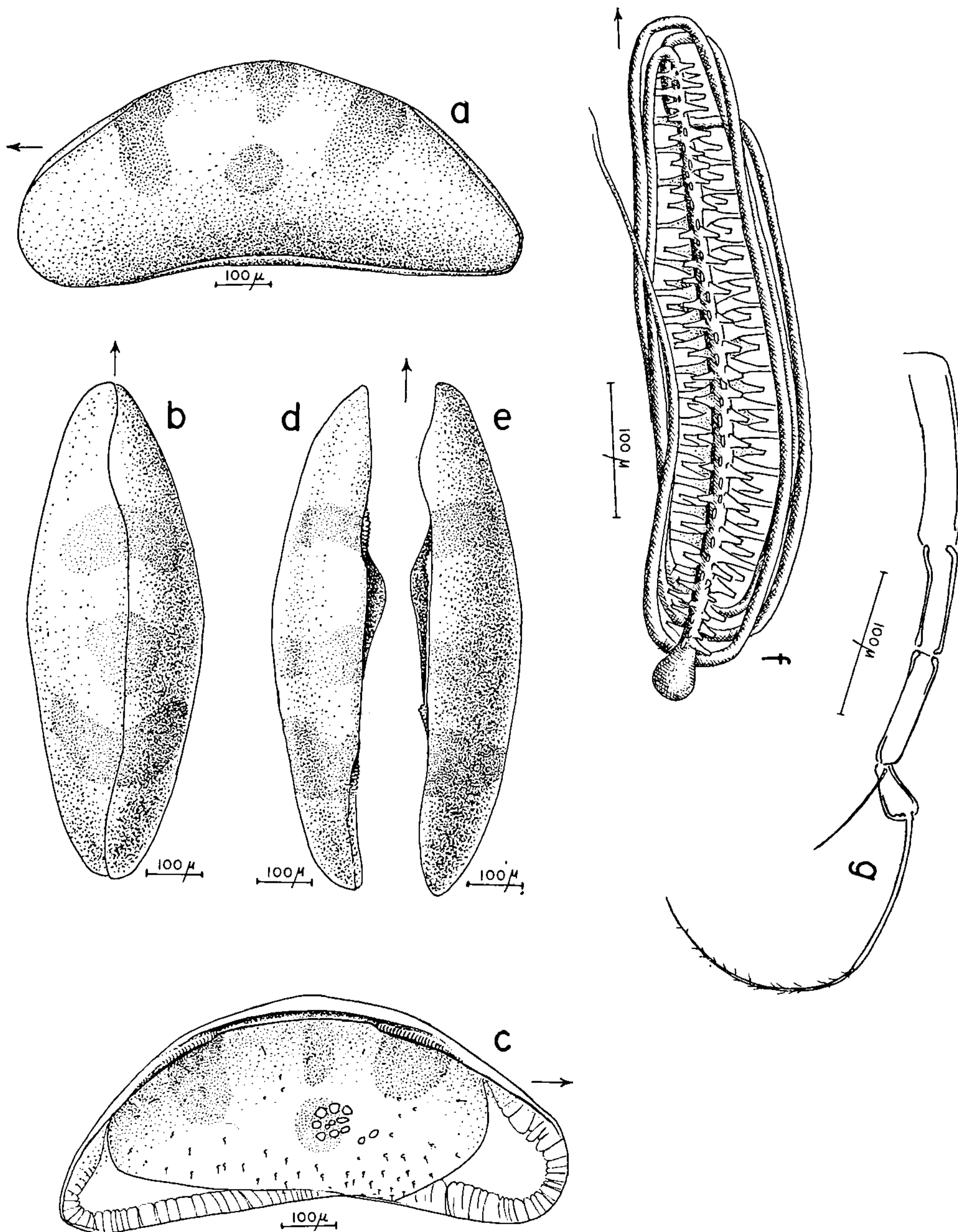

Figure 11. *Macrocyprina vargata* sp. nov. a-b, holotype, USNM 128095; a, lateral left valve view of adult carapace; b, dorsal view of adult carapace, c-e, paratype, USNM 128096; c, interior view of adult left valve; d, dorsal view of adult left valve; e, dorsal view of adult right valve. f, ejaculatory duct, g, third thoracic leg.

greater relative size, and does not tend to form bands but rather spots in *M. propinqua*.

Macrocyprina vargata is also like the southern hemisphere species *M. decora* (Brady, 1866) in general shape though more terminally blunt, as seen from above, and smaller with adult lengths ranging from 900-940 μ as opposed to 1005-1010 μ as cited by Brady (1866, 1880). In addition, the color markings between the two species differ considerably (compare with Brady, 1880, pl. 6, figs. 8a-b).

The species also resembles *Macrocypris succinea* Müller, 1894, from the Gulf of Naples in general shape but, again, is more bluntly pointed in dorsal view. In these two species the central muscle scar patterns are comparable each with the same number of scars in approximately the same relative positions. The two small frontal scars shown on Müller's pl. 13, fig. 25 do not appear on *M. vargata*, however. The male ejaculatory apparatus (Zenker's organ) in the two species has the same characteristics, i.e., a central spiny shaft terminating posteriorly in a smooth bulb-like structure and the same complexly twisted tubing. In *M. vargata*, however, the posterior bulb-like structure is much smaller and the central shaft and tubing are much narrower. Also, the central shaft possesses more and longer spines. Zenker's organ of *M. propinqua* and *M. vargata* appear very similar.

The specific name denotes the broad vertical color stripes shown in living individuals, *vargatus* (L.), 'striped.'

Subfamily Cypridopsinae Kaufmann, 1900

Genus *Potamocypris* Brady, 1870

***Potamocypris insularis* sp. nov.**

Figure 12

Diagnosis. — Smooth, highly unequivalved species of *Potamocypris* with posterior flange of left valve overreaching right valve. As seen from above, anterior terminating in sharp point canted slightly to the left.

Description. — In side view: carapace high, length/height ratio about 1.6; length of adult 600-700 μ ; outline subtriangular, highest point just anterior to midlength at highly angled dorsum; ventral margin straight to slightly concave; posterior margin of right valve steeply truncate; bluntly pointed near venter in left valve; right valve larger than left valve, overreaching left valve along dorsum where it is considerably higher and along venter and anterior; left valve overreaching right valve posteriorly as a caudal flange. In dorsal view: length/width ratio from 2.5 to 2.9; outline irregularly lenticular; greatest width near midlength, anterior sharply pointed, posterior bluntly pointed.

Calcified duplicature poorly developed, present only in left valve anterior. Radial pore canals short, simple. Normal pores numerous, small, open type. Hinge adont. Adductor muscle scar pattern composed of five scars, top scar elongate, second and third an oblong pair, fourth scar elongate, fifth scar small, circular.

Dimensions. —

	<i>Length</i>	<i>Height</i>	<i>Width</i>
USNM, Holotype 128099. Adult carapace, sta. B-4244, 47	692	416	250
USNM, Paratype 128100. Adult right valve, sta. B-4244, 47	612	333	113
SDNH, Paratype 04204. Adult carapace, sta. B-4244, 47	701	412	258
SDNH, Paratype 04205. Adult carapace, sta. B-4244, 47	677	392	234

Discussion. — *Potamocypris insularis* has only five scars in the adductor pattern, unlike most species of the genus which have six or seven. There is an apparent reduction occurring in the ventral part of the pattern.

The closest living *Potamocypris* to Clipperton Island is *P. islagrandensis* which occurs

in Lake Nicaragua, Central America. *Potamocypris insularis* is relatively higher, has a pointed posterior and has a different adductor muscle scar pattern than *P. islagrandensis* (Swain and Gilby, 1964).

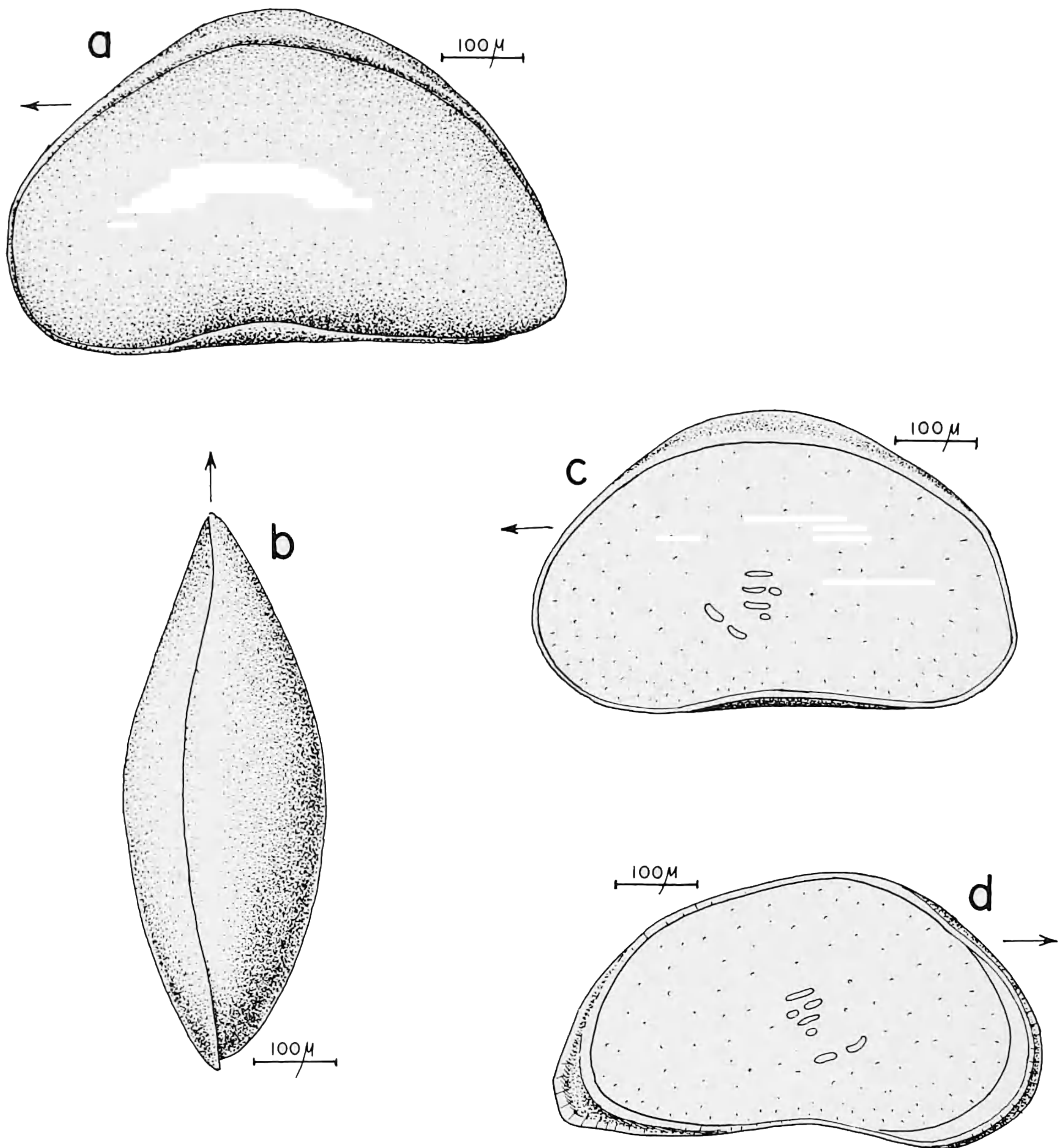

Figure 12. *Potamocypris insularis* sp. nov. a-b, holotype, USNM 128099; a, lateral left valve view of adult carapace; b, dorsal view of adult carapace. c-d, paratype, USNM 128100; c, interior view of adult right valve; d, interior view of adult left valve.

Genus *Cypridopsis* Brady, 1868

Cypridopsis oceanus sp. nov.

Figure 13

Diagnosis.— Carapace small, 580 μ in length; smooth; moderately inflated (length/width = 1.60); greatest height and width near midlength.

Description.— Carapace thin, transparent, smooth; living specimens covered with sparse short hairs; width slightly greater than height, length 1.60 times width. In side view: dorsal margin sloping off straight posteriorly and anteriorly from angled high point at carapace midlength; posterior and anterior margins similarly shaped, broadly rounded; ventral margin straight to slightly concave; valves somewhat unequal, left valve slightly over-

THIS PAGE IS LOCKED TO FREE MEMBERS
Purchase full membership to immediately unlock this page

DELVE INTO FANTASY, MAGIC, MYTHOLOGY & FOLKLORE

Forgotten Books'
Full Membership gives
access to 797,885 ancient
and modern, fiction and
non-fiction books.

Continue

*Fair usage policy applies

Discussion.— This species bears some resemblance to *Cypridopsis vidua* (O. F. Müller, 1776) but is much smaller, unpitted, and has a blunter posterior viewed from the side. Also, there are six adductor scars as in *C. vidua* but their relative positions differ (compare with Morkhoven, 1963, p. 48). The size of *Cypridopsis oceanus* is consistently less than 600 microns compared with 700 microns for *C. vidua* (Wagner, 1957).

The actual salinity range of the lagoon when the species was collected is not known; however, it was palatable. Allison noted when diving in the lagoon that the salinity increased with depth. Breakers will occasionally reach the lagoon during storms. Considering these factors, *Cypridopsis oceanus* probably has a much higher salinity tolerance than *C. vidua* which apparently cannot survive marine salinities greater than 0.8 ‰ (Wagner, 1957:110; Reyment, 1964:75).

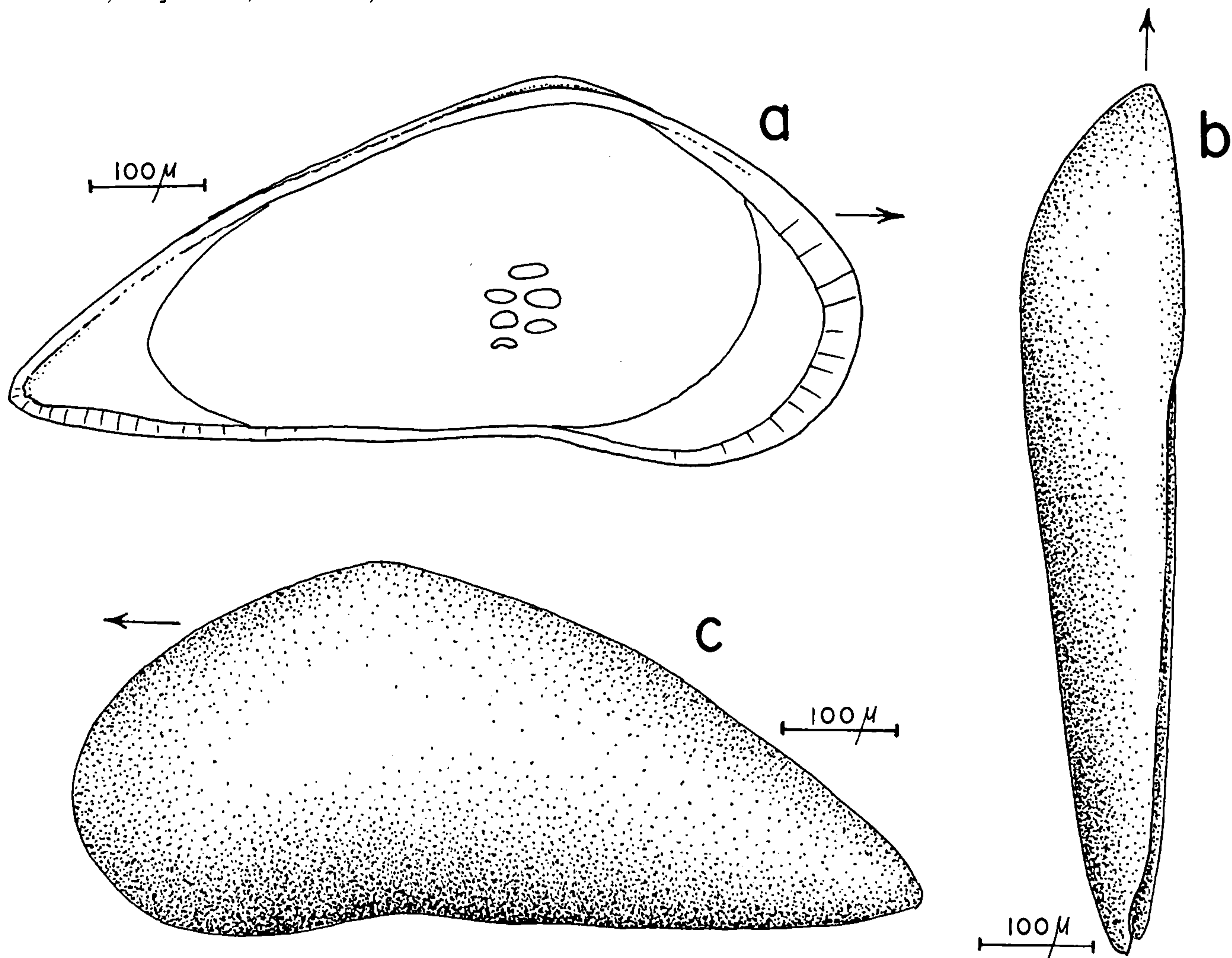

Figure 14. *Pontocypris?* sp. a-c, specimen, USNM 128070; a, interior view of adult left valve; b, dorsal view of adult left valve; c, lateral view of adult left valve.

Subfamily Pontocypridinae Müller, 1894

Genus *Pontocypris* Sars, 1866

Pontocypris? sp.

Figure 14

Description. — Carapace acuminate posteriorly, terminating in a sharply pointed posterior in both dorsal and side views. In side view: greatest height at sharply angled point in anterior third; anterodorsum and posterodorsum sloping away from the highest point at angles of about 30° from the horizontal; posterodorsal margin almost straight, terminating

in pointed ventral posterium; ventral margin straight except for slight convexity at inturned area. In dorsal view: carapace compressed, greatest width in anterior quarter, right valve overlapping left valve posterior to greatest carapace height in anterior third.

Duplicature wide in both posterior and anterior parts of valve. Fused zones narrow, containing several straight, simple radial pore canals. About six oblong adductor scars located in region above inturned area.

Dimensions. —

	<i>Length</i>	<i>Height</i>	<i>Width</i>
Specimen USNM 128070. Adult left valve, sta. B-6101	740	347	140
Specimen SDNH 04210. Adult carapace, sta. B-6120	742	342	228
Specimen SDNH 04211. Adult left valve, sta. B-6120	726	317	119
Specimen USNM 128071. 6th instar carapace, sta. B-6120	512	227	158
Specimen SDNH 04212. 6th instar right valve, sta. B-6120	524	212	90
Specimen SDNH 04213. 5th instar carapace, sta. B-6120	411	170	142
Specimen USNM 128072. 4th instar carapace, sta. B-6120	325	134	117

Discussion. — The carapace, as seen in side view, has the triangular shape of *Pontocypris* but the muscle scar pattern suggests the genus *Propontocypris*. The two genera originally were established on the basis of soft parts not preserved in the Clipperton collection.

Pontocypris? sp. is best compared to *P. accuminata* Müller, 1894, from the Gulf of Naples. The Clipperton species has, however, a straighter dorsal margin in the posterior two thirds, is more posteriorly acuminate and internally it has a less extensive duplicature and lacks the typical *Pontocypris* muscle scar pattern.

Superfamily Cytheracea Baird, 1850

Family Bythocytheridae Sars, 1926

Genus *Pseudocythere* Sars, 1866

Pseudocythere caudata Sars, 1866

Figure 15

Pseudocythere caudata Sars, 1866:88; Brady, 1868:453, pl. 34, figs. 49-52; Brady, 1880:144, pl. 1, figs. 6a-d; Müller, 1894:285, pl. 16, figs. 5, 10, 30-36; Tressler, 1941:102, pl. 19, fig. 15; Wagner, 1957:35, pl. 12; Benson, 1964:13, pl. 1, fig. 8; text-fig. 7.

Pseudocythere IA Maddocks, 1966:62, text fig. 46, no. 2.

Diagnosis. — Because there is little agreement on what the salient characteristics are that define this species, a diagnosis is not presented here.

Description. — Side view: dorsal margin almost straight from top of high truncate caudal process to anterodorsal cardinal angle; anterior margin broadly rounded; ventral margin concave downward at centrally located inturned area; posteroventral margin formed by broad compressed marginal flange. Valves ornamented by continuous, discontinuous, occasionally merging, narrow horizontal ridges everywhere except on most of caudal process and on posteroventral flange which are smooth. In dorsal view: valve evenly inflated along length excluding laterally compressed caudal process; width of carapace would measure one-half length in entire specimen.

Duplicatures broad with large vestibules occupying one-half of duplicature width. Radial pore canals straight, some with enlargements near line of conchescences, sparse, about 10 anteriorly, relatively abundant in ventral half, about eight posteriorly. Normal pores not observed. Hinge weakly developed with elongate bar and subjacent groove. Adductor muscle scar pattern of three horizontally elongate scars in vertical row, bottom scar possibly two fused scars. Oval frontal scar anterior to topmost adductor scar. Soft parts not preserved.

Dimensions. —

Hypotype, USNM 128073. Adult right valve, sta. B-6120

<i>Length</i>	<i>Height</i>	<i>Width</i>
285	158	69

Discussion. — Benson (1964:14) pointed out the improbability that all the reports of *Pseudocythere caudata* are referable to one species. However, no serious attempt has been made to separate this geographically widespread group into species or even subspecies. The single specimen found at station B-6120 is identified as *P. caudata* because it falls within the range of variation of other known populations and insufficient material does not allow a more critical analysis of it here.

Further studies may show that more important differences occur between warm water and cold water forms, irrespective of depth of water, than between forms separated by great distances of longitude. This relationship is suggested by a close resemblance between the Clipperton Island specimen and another shallow water reef form from northern Madagascar (Maddocks, 1966). In side view, specimens from both areas lack the posteroventral spine, at least in the right valve, and are more quadrate, with almost parallel ventral and dorsal margins, than the subtriangular, spined forms reported from cold or deep water areas. Future taxonomists should pay particular attention to the number of

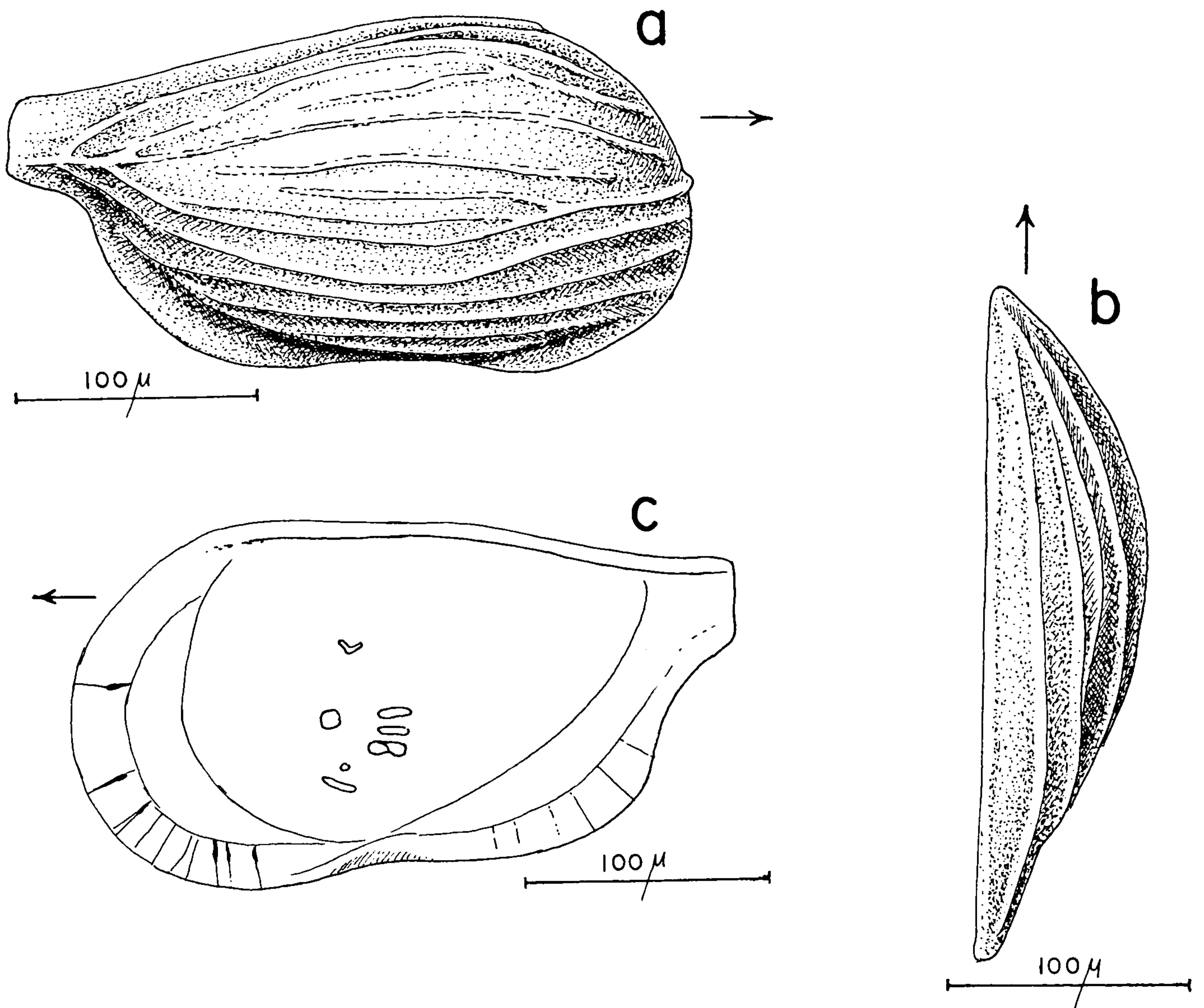

Figure 15. *Pseudocythere caudata* Sars, 1866. a-c, hypotype, USNM 128073; a, lateral view of adult right valve; b, dorsal view of adult right valve; c, interior view of adult right valve.

THIS PAGE IS LOCKED TO FREE MEMBERS
Purchase full membership to immediately unlock this page

FORGOTTEN BOOKS

FULL MEMBERSHIP

797,885 Books!
All you can read
for only
\$8.99/month

Continue

*Fair usage policy applies



inflated laterally, but are no wider, and tend to be lenticular in dorsal view. Holden (1964:413) noted a similar kind of dimorphism in *Eucytherura spinata* from the Upper Cretaceous of California. The typical type of dimorphism in *Eucytherura* results in lower and longer males (Morkhoven, 1963:357).

Ornamentation is variably developed. In the inflated females, an arcuate row of about five or six tubercles runs from the eye tubercle to the posteroventral swelling *via* the subcentral area and then up to the posterodorsum (Figure 16g). In the males the tubercles are mostly lost at the expense of the various swellings.

One of the most prominent features is the large eye tubercles. The species appears to be related to *Eucytherura gibbera* Müller, 1894, which has a similar type of ornamentation

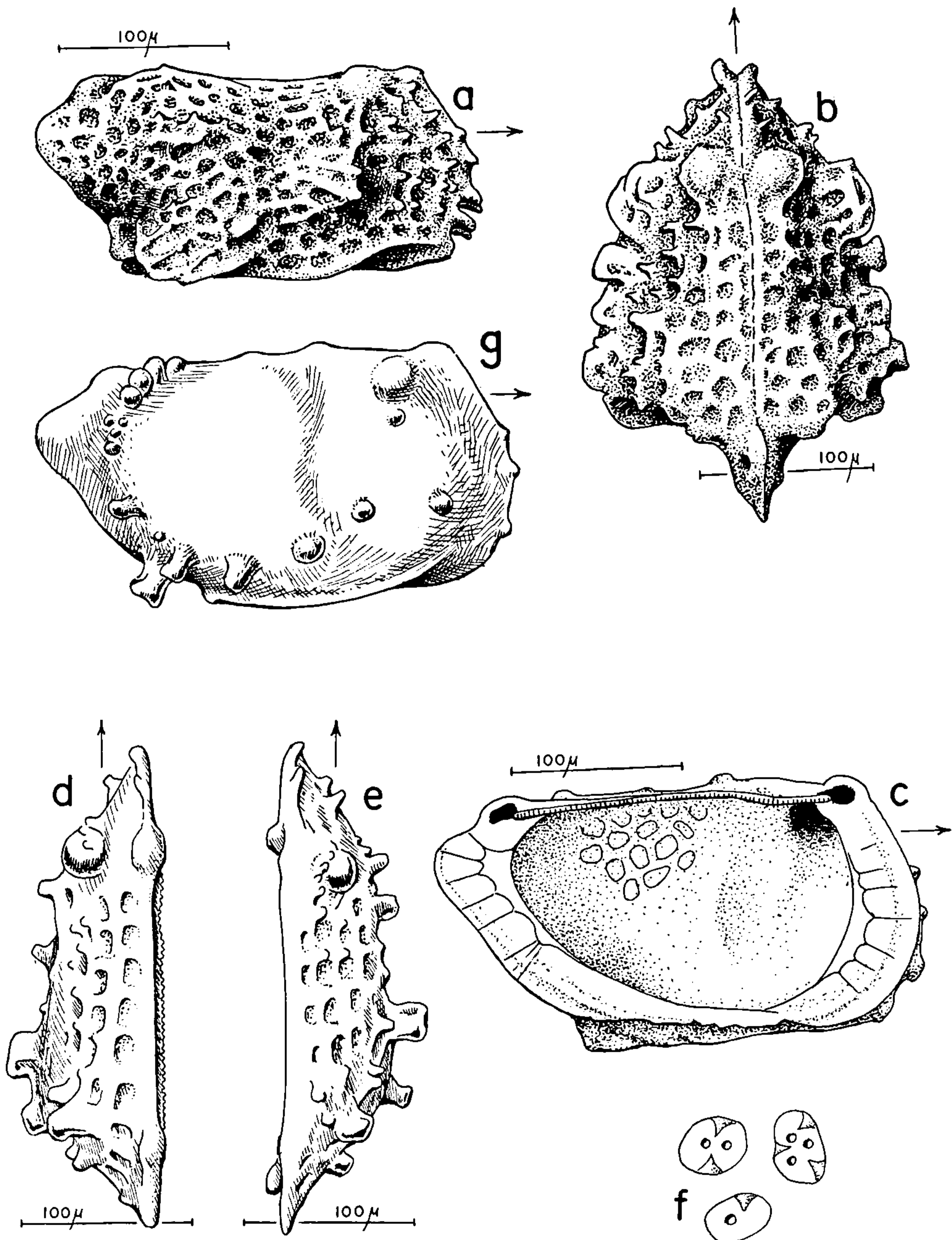

Figure 16. *Eucytherura binocula* sp. nov. a-b, holotype, USNM 128103; a, lateral left valve view of adult carapace; b, dorsal view of adult carapace. c-d, paratype, USNM 128104; c, interior view of adult left valve; d, dorsal view of adult left valve. e, paratype, SDNH 04214; dorsal view of adult right valve. f, normal pores within reticulæ as seen with transmitted light. g, generalized sketch showing tubercle arrangement on the female carapace, reticulations not drawn in.

and large eye tubercles. According to Bold (pers. comm.) the species is similar but not identical to species living in the Caribbean.

The species is named with reference to its very large eye tubercles.

Genus *Paracytheridea* Müller, 1894

Paracytheridea tschoppi Bold, 1946

Figures 17, 18, 19

Paracytheridea tschoppi van den Bold, 1946:85. pl. 16, figs. 6-7; van den Bold, 1957:245, pl. 4, fig. 7; Benson and Coleman, 1963:33, pl. 6, figs. 7, 9, 10, 20.

Paracytheridea granti Swain, 1967:70 (in part), pl. 4, figs. 10, 11a, b, pl. 5, figs. 2a, b, 4a-c, 5, text fig. 47a.

Diagnosis.— Sharply and prominently caudate *Paracytheridea* with posterodorsal swelling supporting 3-4 flange-like oblique ridges, horizontal alar ridge continuous to anterior margin; posterior toothlet complex in hinge of right valve well developed; projecting anterior toothlet complex poorly developed and not projecting.

Description.— In side view: outline of dorsum and venter parallel due to posteroventer massive ala: dorsal and ventral margins actually highly and posteriorly acuminate, terminating in well developed pointed caudal process at posterior midheight; anterior margin of right valve broadly rounded, obliquely rounded in left valve due to extended anterocardinal wing. In dorsal view: greatest carapace width in posterior third, height/length ratio of 0.65 to 0.75. Valves deeply sulcate at midlength in dorsal three-quarters dividing subcentral tubercle and highly inflated posterodorsal swelling. Ornamentation principally of flange-like ridges characteristically arranged as discussed further on.

Duplicature wide, nonvestibulate duplicatures transected by sparse radial pore canals; radial pore canals mostly false, about 12 anteriorly, 3 posteriorly, one of which occupies conspicuous subcaudal dentical. Normal pores sieve type, sparse, sieve plate usually a horseshoe shaped structure with about 25 perforations. Hinge lobodont, right valve with prominent posterior element of five distinct toothlets, anterior element of five poorly

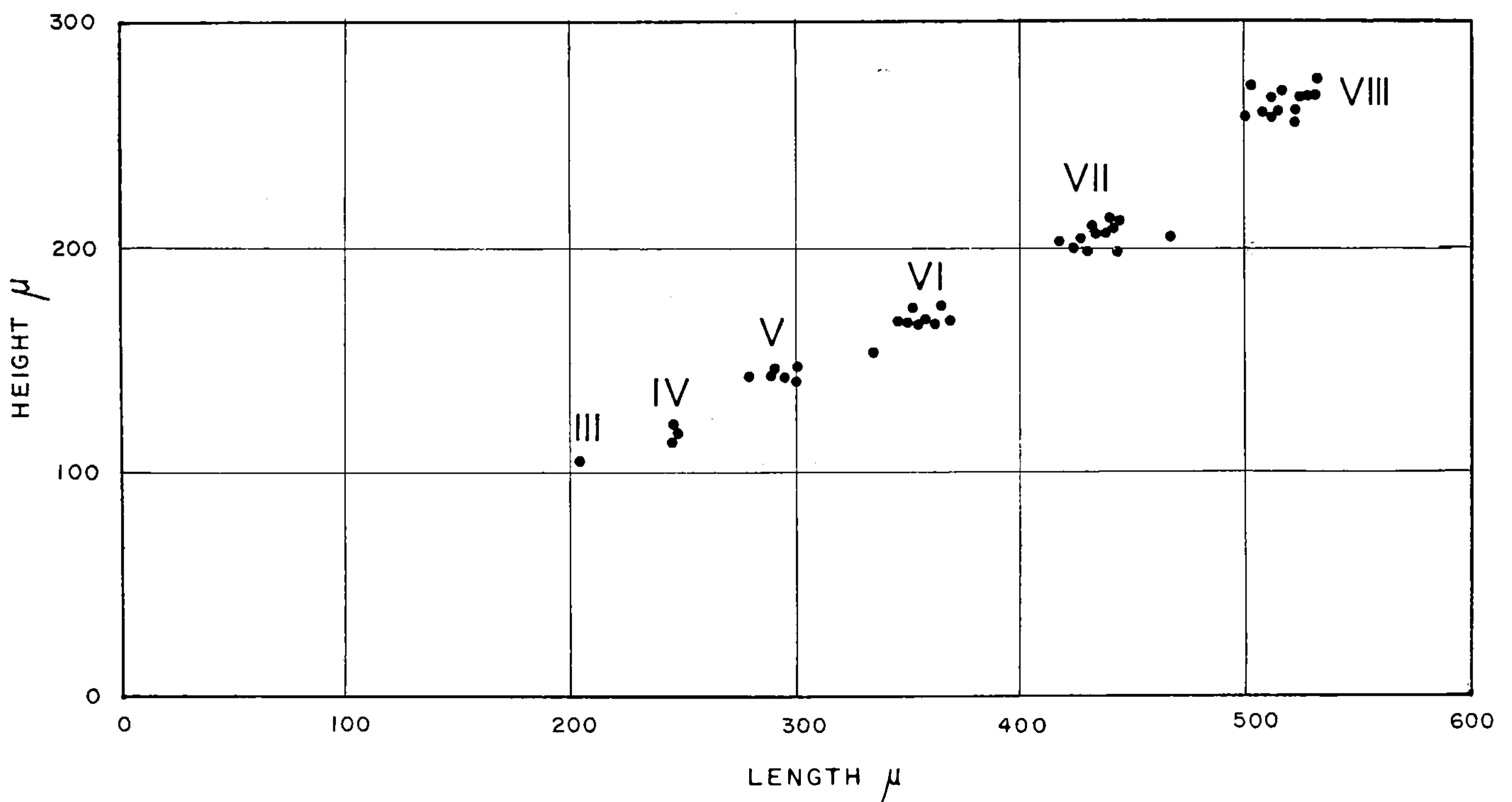

Figure 17. Length-height plot of six growth stages of *Paracytheridea tschoppi* Bold from stations B-6101 and B-6120. In all cases measurements were taken on entire carapace or the larger left valves.

developed toothlets, wavy median groove with about 20-25 notches. Five adductor muscle scars on posterior side of well developed circular subcentral depression, second and third scars up may be a divided scar preserving the fundamental pattern of four scars for the adductor group. Frontal scars located on anterior side of subcentral depression numbering six in two pairs of three, one group above the other.

Sexual dimorphism not observed.

Dimensions.— The following information was determined from a collection of 35 adult carapaces: $L = 520 \pm 20.6 \mu$; $H = 261 \pm 18.4 \mu$. Nineteen adult carapaces gave a mean width of 380μ with a range from 348μ to 405μ .

Dimensions.—

	<i>Length</i>	<i>Height</i>	<i>Width</i>
Hypotype, USNM 128074. Adult right valve, sta. B-6101	514	241	192
Hypotype, USNM 128074. Adult left valve, sta. B-6101	517	267	192
Hypotype, SDNH 04218. Adult carapace, sta. B-6101	524	251	360
Hypotype, SDNH 04219. Adult carapace, sta. B-6101	530	275	367
Hypotype, SDNH 04220. Penultimate carapace, sta. B-6101	449	209	300
Hypotype, USNM 128075. Penultimate left valve, sta. B-6101	430	204	150
Hypotype, USNM 128076. 6th instar carapace, sta. B-6101	364	167	237
Hypotype, USNM 128077. 5th instar carapace, sta. B-6101	300	142	203
Hypotype, USNM 128078. 4th instar carapace, sta. B-6100	203	102	143

Discussion.— *Paracytheridea tschoppi* has not previously been reported from the Pacific region though it is known to be widespread in the Caribbean and parts of the Gulf of Mexico (Bold, 1946, 1957; Benson and Coleman, 1963). We believe that minor differences in shell morphology are not sufficient evidence to separate the closely related populations of *P. tschoppi* in the Gulf of California and Clipperton Island from those in the Caribbean and Gulf of Mexico.

Terminology is introduced in Figure 18 for the ridge arrangement of *Paracytheridea*. It is assumed that the positions, if not the degree of development, of ridges ornamenting the valves of this genus are genetically controlled.

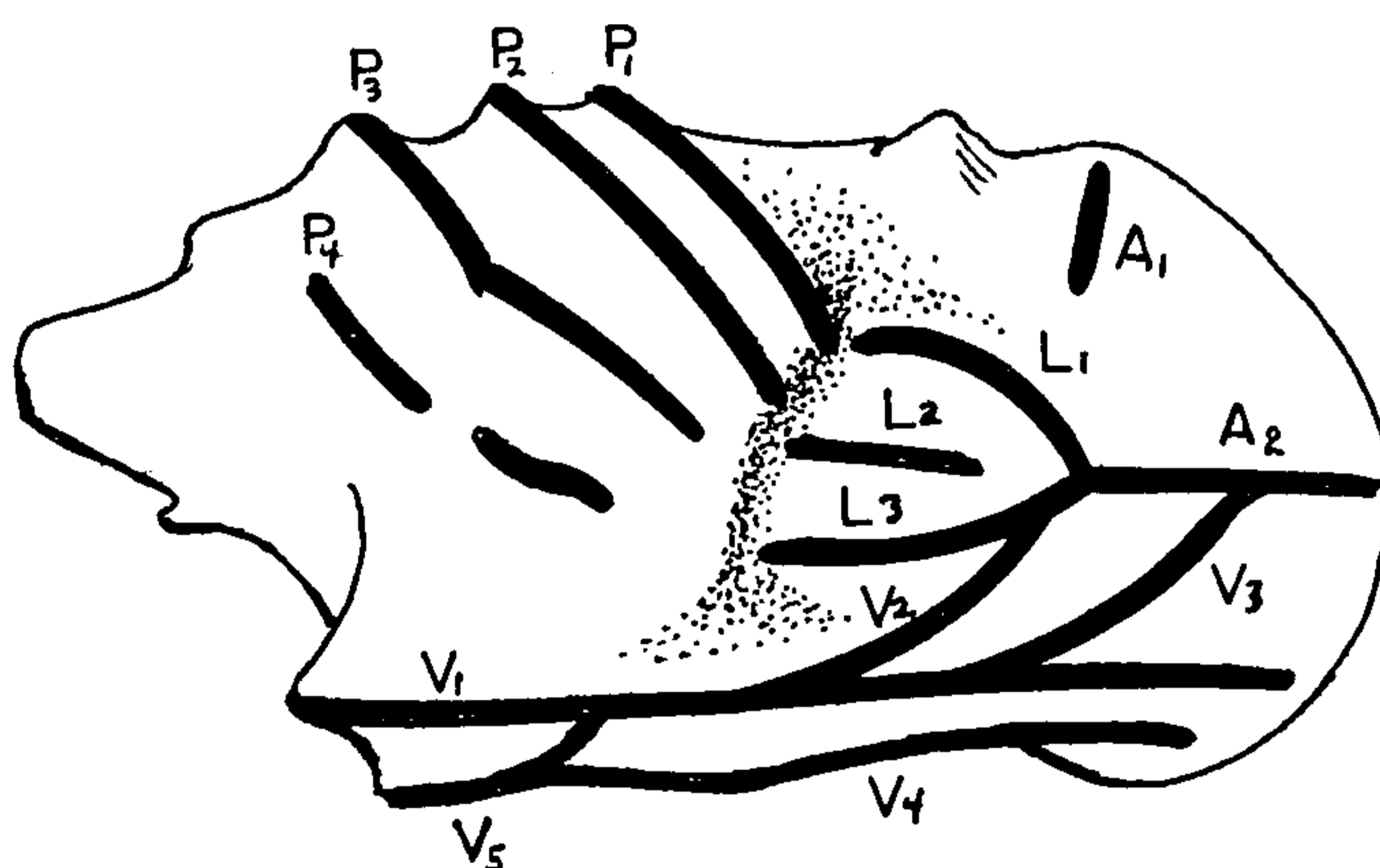

Figure 18. Schematic diagram of *Paracytheridea* ornamentation. A, L, P, and V represent the anterior, lateral, posterior, and ventral ridges, respectively.

The Pliocene to Holocene *Paracytheridea granti* Le Roy, 1943 of California and Baja California has been confused with *P. tschoppi*. *Paracytheridea granti* lacks the pronounced posterodorsal swelling and possesses a more prominent posterodorsal cardinal angle than *P. tschoppi*. In *P. tschoppi* a P_2 or P_3 extends into the posterocardinal region. Ridge ornamentation in *P. granti* is distinctive with a P_2 or P_3 running continuously into L_1 which joins A_2 and which is the only horizontal ridge reaching the anterior margin. In *P. tschoppi*, both A_2 and V_1 reach the anterior margin. In *P. granti* V_1 ultimately joins V_3

THIS PAGE IS LOCKED TO FREE MEMBERS
Purchase full membership to immediately unlock this page

DELVE INTO FANTASY, MAGIC, MYTHOLOGY & FOLKLORE

Forgotten Books'
Full Membership gives
access to 797,885 ancient
and modern, fiction and
non-fiction books.

Continue

*Fair usage policy applies

Genus *Semicytherura* Wagner, 1957
Semicytherura quadraplana sp. nov.

Figure 20

Diagnosis. — Small *Semicytherura* with high pointed caudal process and ridge ornamentation resulting in minutely pitted posteroventral, anteroventral, and central fields when viewed from the side; alate as seen from above.

Description. — Carapace heavy, small, 260 to 290 μ long. In side view: dorsal margin nearly straight, parallel with straight ventral margin; venter very wide and flat; anterior margin obliquely rounded, ventral half with four stubby marginal knobs; posterior margin truncate beneath high, pointed caudal process; periphery of valves with continuous smooth ridge, doubled along anterior margin and complex along dorsal margin; smooth lateral ridge departing at right angle from anterior ridge at midheight, swinging down to venter along the edge of wide alar process, then swinging irregularly back up to posterocardinal angle thus creating two nearly equal fields in anteroventer and posteroventer with larger central field between; compressed caudal area a fourth field; right valve somewhat higher, overreaching left valve along dorsum. In dorsal view: carapace compressed in dorsal half; greatest width along ventral midlength on well developed alar process; anterior blunt due to doubled marginal ridge system; posterior compressed, pointed at caudal process.

Duplicatures broad; posterior duplicature greatly extended inward, almost to middle of valve; posterior radial pore canals mostly false, some passing through marginal spine at posteroventer, at least one running full length of caudal process; anterior duplicature wide, with 15 to 20 irregular, enlarged, sometimes dividing radial pore canals; no vestibules. Normal pores numerous, tiny, in small clusters of one to 18, each cluster apparently narrowing to small external pit. Hinge elements of right valve consist of smooth anterior tooth, flange-like posterior tooth, and crenulate median groove. Four oblong adductor muscle scars form vertical row in lower half of valve; elongate single frontal scar anterior to topmost adductor scar.

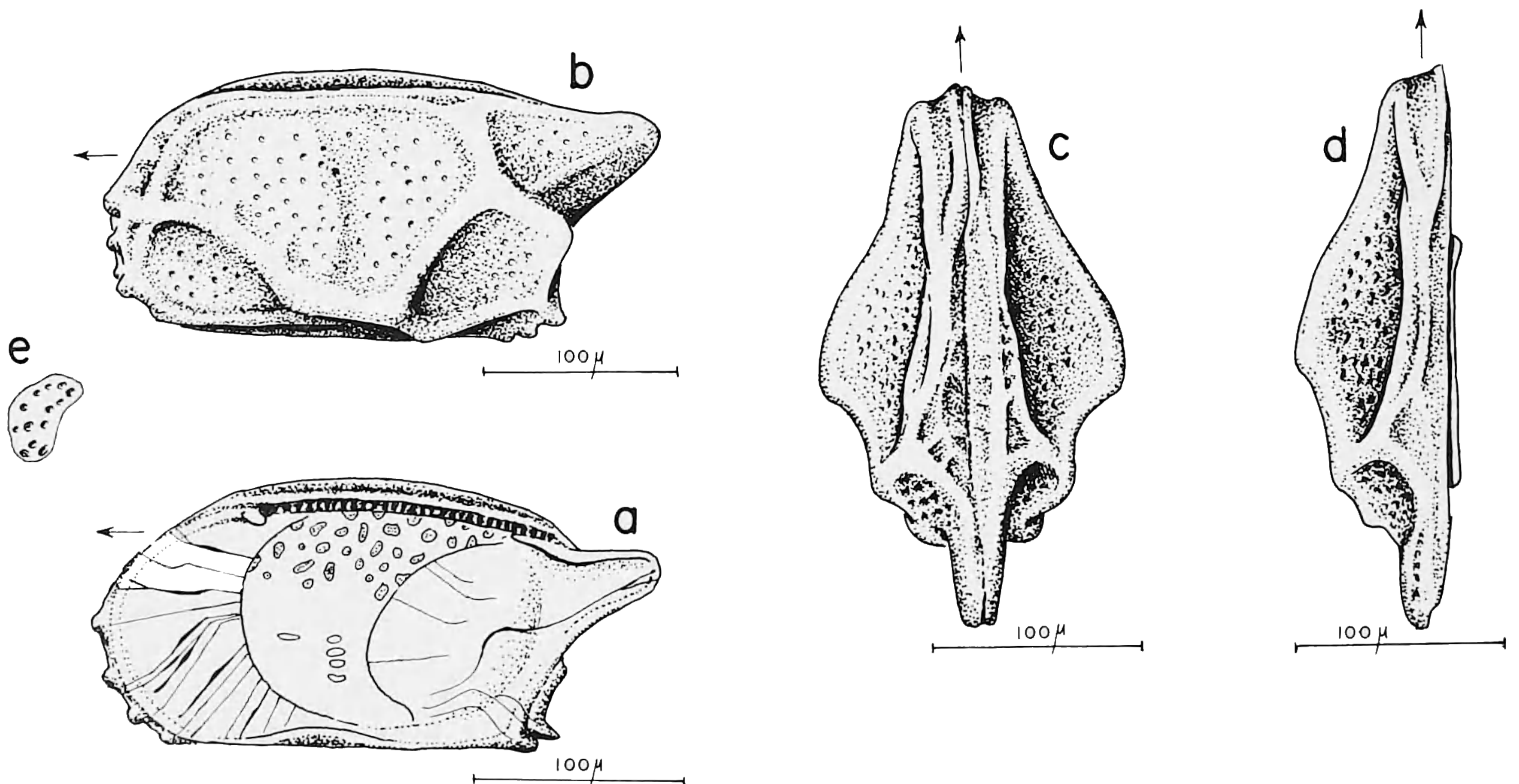

Figure 20. *Semicytherura quadraplana* sp. nov. a, paratype, USNM 128106; internal view of adult right valve. b, holotype, USNM 128105; external left valve view of adult carapace. c, paratype, SDNH 04221; dorsal view of left valve. e, enlarged view of normal pore cluster as seen with transmitted light.

Dimensions. —

	<i>Length</i>	<i>Height</i>	<i>Width</i>
Holotype, USNM 128105. Adult carapace, sta. B-6100	289	132	137
Paratype, USNM 128106. Adult right valve, sta. B-6100	275	133	70
Paratype, SDNH 04221. Adult left valve, sta. B-6100	276	129	73
Paratype, SDNH 04222. Adult carapace, sta. B-6100	267	129	140
Paratype, USNM 128107. Adult carapace, sta. B-6100	276	136	137
Paratype, SDNH 04223. Adult carapace, sta. B-6100	277	133	134
Paratype, SDNH 04224. Adult carapace, sta. B-6100	269	129	134

Discussion. — The ridge arrangement of *Semicytherura quadraplana* is somewhat similar to that found on *S. quadrata* (Hanai, 1957:20) from Japan, though these species differ in other aspects. The strongly developed alae set this new species apart from any known *Semicytherura*. The unique ridge arrangement is a result of the singular lateral ridge following each ala to the venter from anterior and posterior midheights.

Family Hemicytheridae Puri, 1953

Genus *Mutilus* Neviani, 1928***Mutilus convergens clippertonensis* subsp. nov.**

Figure 21, 22

Aurila convergens Swain, 1967:79, pl. 8, fig. 8; Gunther, 1967:97, pl. 1, fig. 8.

Diagnosis. — A species of *Mutilus* with highly arched dorsum, well developed posterodorsal tubercle, prominent ornamental ridge and furrow from posterodorsum to anteroventer across dorsolateral-anterolateral areas.

Description. — In side view: margins rounded except at small pointed caudal process near

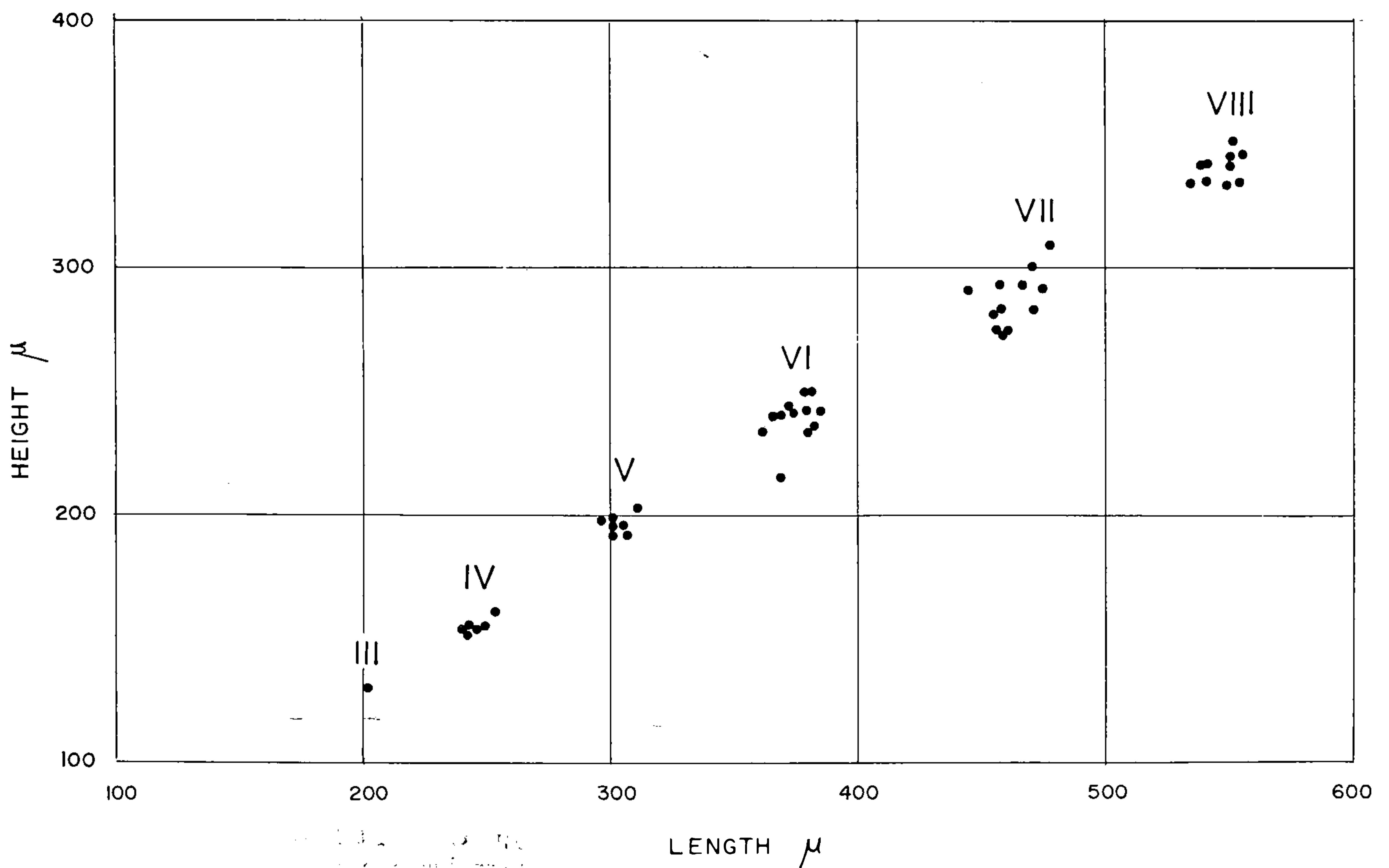

Figure 21. Length-height plot of six growth stages of *Mutilus convergens clippertonensis* subsp. nov. from stations B-4241, B-6101, and B-6100. All measurements taken on complete carapaces or the larger left valves. Labeling of the instars assumes that the species has eight growth stages.

posteroventer beneath slightly concave posterium; dorsum gently rounded, continuous with obliquely rounded anterior margin; ventral margin sinuous, slightly concave downward at inturned area; right valve somewhat larger than left valve, overreaching left valve along posterior, dorsum, and part of anterior margins; prominent angled posterodorsal tubercle at juncture of ornamental ridges. Ornamentation of six horizontally trending ridges with large reticulations in intermediate furrows; two parallel sinuous ridges extend from posteroventer to anteroventer; prominent ridge and furrow from posterodorsal tubercle to anteroventer via dorsolateral-anterolateral areas. In dorsal view: carapace lenticular, greatest width at midlength; anterior and posterior blunt. Eye tubercles small, on heavy marginal rim system. Males present but shell dimorphism not apparent.

Duplicature about $50\ \mu$ wide, continuous along venter. Radial pore canals abundant,

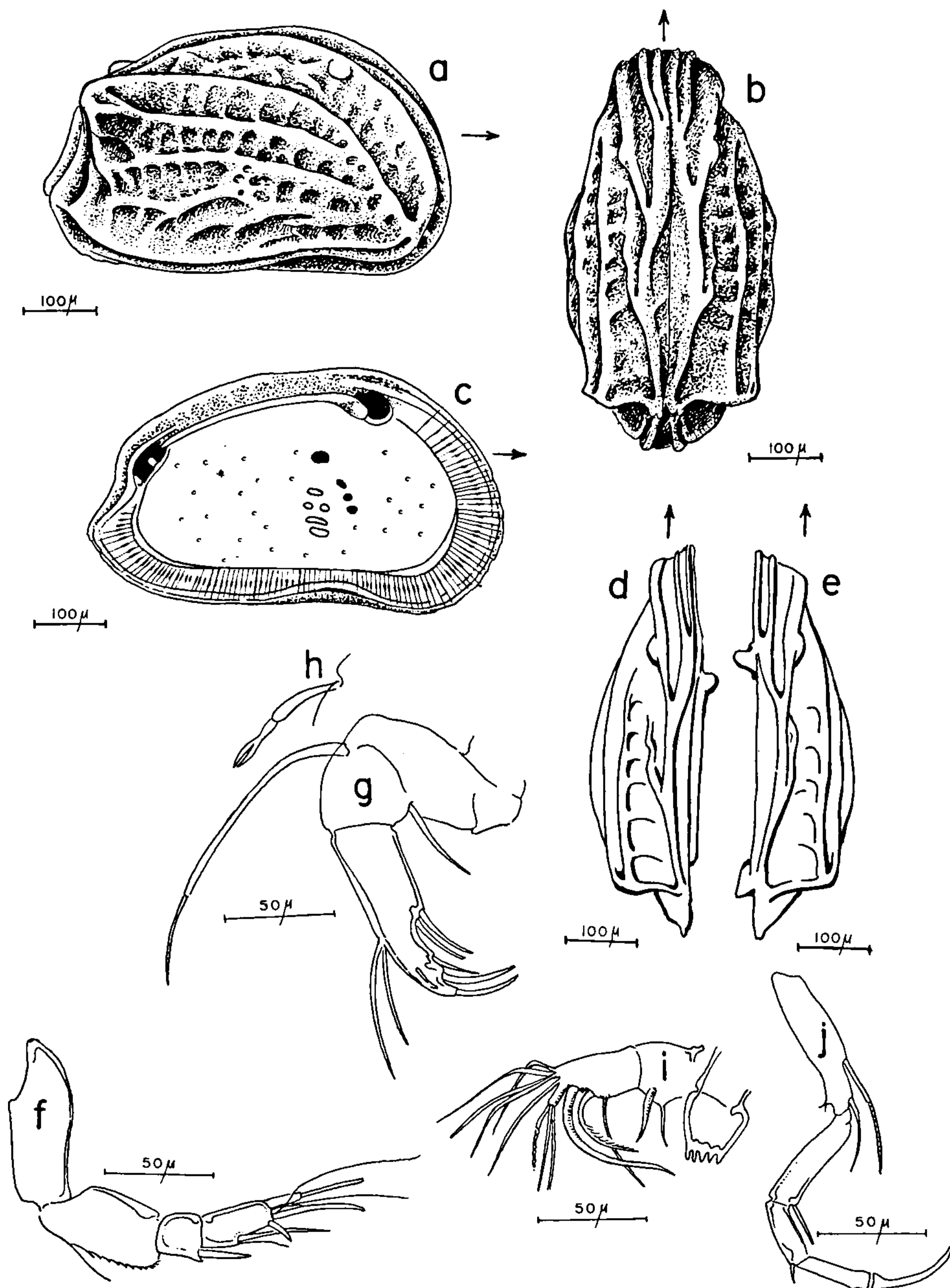

Figure 22. *Mutilus convergens clippertonensis* subsp. nov. a-b, paratype, USNM 128109; a, external right valve view of adult carapace; b, dorsal view. c, holotype, USNM 128108; internal view of adult left valve. d, paratype, SDNH 04226; dorsal view of adult left valve. e, paratype, SDNH 04225; dorsal view of adult right valve. f, 1st antenna (incomplete). g, male 2nd antenna with long spineret bristle. h, female, 2nd antenna in part showing reduced spineret bristle. i, mandible and maxilla. j, 1st thoracic leg.

THIS PAGE IS LOCKED TO FREE MEMBERS
Purchase full membership to immediately unlock this page

FORGOTTEN BOOKS

FULL MEMBERSHIP

797,885 Books!
All you can read
for only
\$8.99/month

Continue

*Fair usage policy applies



anterior and on swellings; large swelling above smaller one between two dorsolateral sulci; antermost sulcus irregular, poorly developed; postermost sulcus well developed, vertical; third dorsolateral swelling behind postermost sulcus poorly developed; small fourth swelling on posterior part of ventrolateral inflation; left valve slightly larger, and overreaching right valve anteriorly and posteriorly. In dorsal view: greatest width in posterior half at ventrolateral swelling; posterior half of carapace inflated; anterior half wedged shaped, pointed.

Duplicature narrow, traversed by sparse, evenly spaced radial pore canals, about 15 posteriorly and anteriorly. Four oblong adductor scars in vertical row in ventral half of valve; single mandibular scar ventral and anterior to adductor group; single frontal scar anterior and dorsal to adductor group. Hinge weak, left valve with terminal depressions (sockets) near cardinal angles.

Dimensions.—

	<i>Length</i>	<i>Height</i>	<i>Width</i>
Holotype, USNM 128112. Adult carapace, sta. B-4244, 47	372	213	184
Paratype, USNM 128113. Adult right valve, sta. B-4244, 47	366	203	75
Paratype, SDNH 04229. Adult carapace, sta. B-4244, 47	358	203	166
Paratype, SDNH 04230. Adult carapace, sta. B-4244, 47	363	212	182
Paratype, SDNH 04231. Adult carapace, sta. B-4244, 47	375	216	179
Paratype, SDNH 04232. Adult right valve, sta. B-4244, 47	363	216	175

Discussion.— *Limnocythere viaticum* is one of three freshwater species found in Clipperton lagoon. The taxon cannot be identified with any known species, though the

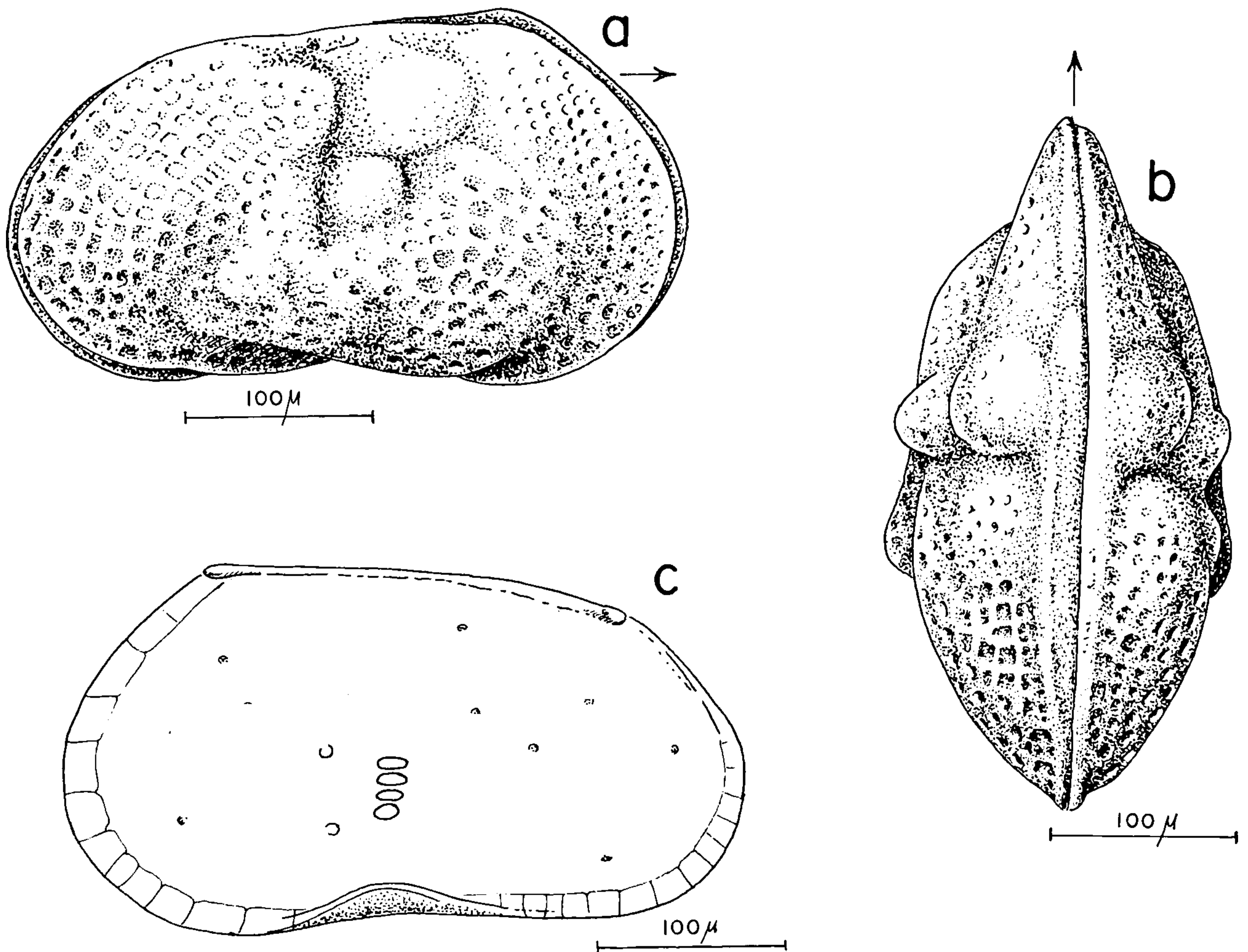

Figure 23. *Limnocythere viaticum* sp. nov. a-b, holotype, USNM 128112; a, lateral right valve view of adult carapace; b, dorsal view of adult carapace. c, paratype, USNM 128113; interior view of adult right valve.

freshwater ostracode faunas of Central America, where one might expect these to have originated, are very poorly known.

As discussed elsewhere, the freshwater lagoon is a relatively recent phenomenon. The specific name alludes to the species, or its ancestors, trip to the island: *viaticum* (L.) "voyager."

Family Paradoxostomatidae Brady and Norman, 1889

Genus *Paradoxostoma* Fischer, 1855

***Paradoxostoma limbaughi* sp. nov.**

Figure 24

Diagnosis.—Elongate *Paradoxostoma* posteriorly terminating at midheight in blunt point; greatest carapace height in posterior half; dorsal view of carapace lenticular and symmetrical except for bluntly pointed anterior.

Description.—Shell fragile, transparent; relatively small for genus, length about 340 μ . In side view: carapace elongate, length 2½ times height; highest point of carapace just posterior to midlength at broadly arched dorsum; posterodorsal margin flattened; posterior margin bluntly pointed at midheight; ventral margin broadly concave downward at inturned area in anterior half, broadly rounded in posterior 2/3 of valve. In dorsal view:

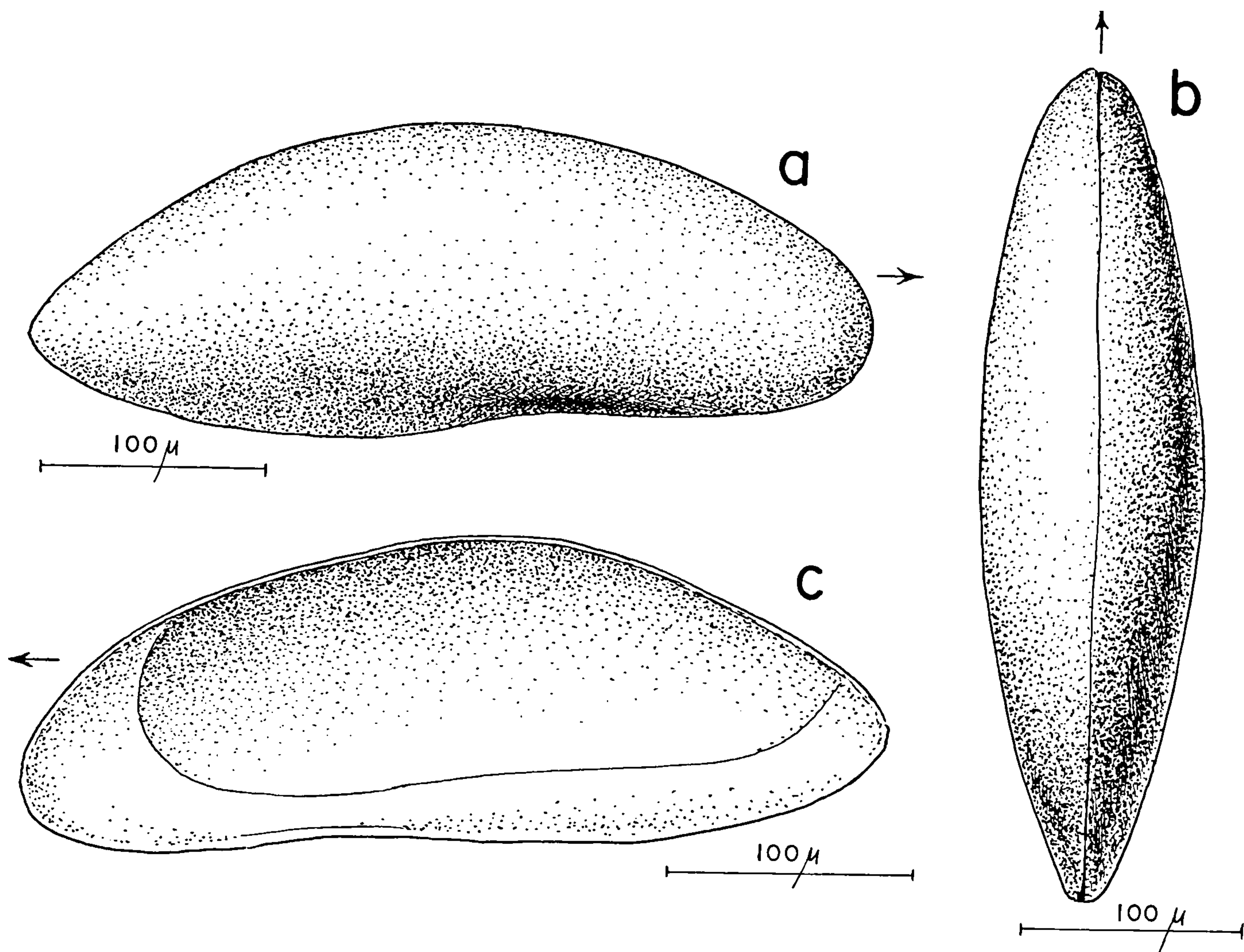

Figure 24. *Paradoxostoma limbaughi* sp. nov. a-b, holotype, USNM 128114; a, lateral right valve view of adult carapace; b, dorsal view of adult carapace. c, paratype, USNM 128115; interior view of adult right valve.

outline symmetrically lenticular except for bluntly pointed anterior; greatest width at midlength. Internal features not discernible.

Dimensions.—

	<i>Length</i>	<i>Height</i>	<i>Width</i>
Holotype, USNM 128114. Adult carapace, sta. B-4241	341	127	90
Paratype, USNM 128115. Adult right valve, sta. B-4241	328	129	50
Paratype, USNM 128116. Adult carapace, sta. B-4241	326	134	92
Paratype, SDNH 04233. Adult carapace, sta. B-4241	334	130	87
Paratype, SDNH 04234. Adult carapace, sta. B-4241	338	135	92
Paratype, SDNH 04235. Adult carapace, sta. B-4241	340	137	93

Discussion.— The species apparently belongs in the genus *Paradoxostoma* based on general morphology; however, it is possible that it could be placed in *Xiphicilus* which is usually more pointed at both ends, or *Cytherois* which is less bluntly pointed.

The species is similar to *Paradoxostoma artum* Bold, 1966, from the Caribbean and *Xiphicilus* sp. cf. *X. arenatus* Brady from New Caledonia in the sense of Apostolescu, 1967.

The species is named for the late Conrad Limbaugh who helped collect the Clipperton Island samples.

Genus *Sclerochilus* Sars, 1866
Sclerochilus sp.

Figure 25

Sclerochilus contortus: Muller, 1894: 282, pl. 16, fig. 2.

Sclerochilus sp. B. Holden, 1967: 39, text figs. 30a-c.

Description.— In side view: shell reniform, with broadly and evenly arched dorsum; ventral margin sinuous, greatly rounded in posterior two-thirds, concave downward in anterior half; carapace relatively high, length/height ratio = 2.0, posterior bluntly pointed at midheight or broadly rounded. In dorsal view: carapace lenticular, compressed, length/width ratio = 2.7; greatest width at midlength, posterior and anterior pointed. Dimorphism not observed.

Duplicature wide; vestibules large; fused zone narrow, with continuous width of about 15 μ . Radial pore canals simple, numbering 20 to 30 throughout duplicature. Normal pores open, small, sparse. Five adductor muscle scars in oblong oblique pattern at midheight of valve just anterior to midlength.

Dimensions.—

	<i>Length</i>	<i>Height</i>	<i>Width</i>
Specimen, USNM 128079. Adult right valve, sta. B-6120	421	210	71
Specimen, USNM 128080. Adult left valve, sta. B-6120	408	208	73
Specimen, SDNH 04236. Adult left valve, sta. B-6120	383	190	75
Specimen, SDNH 04237. Adult right valve, sta. B-6120	398	193	65
Specimen, SDNH 04238. Penultimate carapace, sta. B-6120	350	176	135

Discussion.— These specimens are identical to *Sclerochilus* sp. B (Holden, 1967) from late Cenozoic drowned terraces in the Hawaiian Islands, and to a form from the Mediterranean identified by Müller (1894) as *S. contortus* (Norman). Müller's illustrations (pl. 16, figs. 1–2) of this form show distinct sexual dimorphism, the males being the lower and relatively more elongate of the two. *Sclerochilus* sp. is similar to the female, illustrated by Müller, but not to the male. These specimens, including Müller's are considered distinct from *S. contortus* (a North Atlantic species) based on differences in the morphology of the shell. Whether only females have been found at Clipperton Island or whether the population

THIS PAGE IS LOCKED TO FREE MEMBERS
Purchase full membership to immediately unlock this page

DELVE INTO FANTASY, MAGIC, MYTHOLOGY & FOLKLORE

Forgotten Books'
Full Membership gives
access to 797,885 ancient
and modern, fiction and
non-fiction books.

Continue

*Fair usage policy applies

leling anterior margin; broad, shallow vertical sulcus anterior to midlength; eye tubercles small, prominent. In dorsal view: carapace compressed, width/length ratio = 0.30, carapace of equal width from subcentral region to posterocardinal region; caudal and anterior parts compressed; valves asymmetric: right valve with more posteriorly extended ridge juncture.

Duplicature moderately broad, shallow vestibule irregularly shaped. Radial pores sometimes branched, commonly with midswellings, about 30 in anterior, 25–30 in posterior. Normal pores small, sieve type. Hinge holamphidont; left valve with entire, projecting, stepped anterior tooth; entire reniform posterior tooth. Smooth median bar of left valve with low, smooth anterior tooth. Three oblong adductor muscle scars on posterior side of subcentral depression; bottom-most scar apparently a fused pair. Large V-shaped frontal scar anterior to top-most adductor scar on side of subcentral depression. Single circular mandibular scar beneath frontal scar.

Dimensions.—

	<i>Length</i>	<i>Height</i>	<i>Width</i>
Holotype, USNM 128117. Adult right valve, sta. B-6120	524	260	75
Holotype, USNM 128117. Adult left valve, sta. B-6120	524	270	89
Paratype, SDNH 04239. Adult right valve, sta. B-6120	523	253	81
Paratype, SDNH 04239. Adult left valve, sta. B-6120	533	266	92
Paratype, SDNH 04240. Adult carapace, sta. B-8558	600	318	184
Paratype, USNM 128118. Adult carapace, sta. B-8558	508	312	191
Paratype, USNM 128119. Adult carapace, sta. B-8558	559	302	175
Paratype, SDNH 04241. 6th instar, sta. B-6120	414	224	141
Paratype, SDNH 04242. 5th instar, sta. B-6120	350	183	146

***Neocaudites pacifica minima* subsp. nov.**

Figure 26

Diagnosis.— Small, length about 450 μ , ornamented with various sized reticulations and pits; small, isolated, denticulate, submarginal ridge paralleling anterior margin; valves asymmetric with dorsal and lateral ridge juncture at posterodorsum more posteriorly extended in right valve; frontal scar s-shaped, four adductor scars.

Description.— Except for the differences stated in the diagnosis above, all other morphological details of *N. pacifica pacifica* are the same as those of this subspecies.

Dimensions.—

	<i>Length</i>	<i>Height</i>	<i>Width</i>
Paratype, USNM 128120. Adult carapace, Hanauma Bay, Hawaiian Islands	424	217	144
Paratype, SDNH 04243. Adult left valve, Hanauma Bay	458	216	100
Paratype, SDNH 04243. Adult right valve, Hanauma Bay	458	209	95

Discussion.— *Neocaudites pacifica minima* from Hanauma Bay, Oahu, Hawaii, is believed to be subspecifically related to *N. pacifica pacifica* from Clipperton Island and is diagnosed here for comparative purposes. The most apparent difference between the two is that of size, *N. pacifica minima* being much smaller (length—450 μ) than that of *N. pacifica pacifica* (length = 525 μ). The Clipperton Island form occurs in deeper waters than the Hawaiian Island form (10 m). At Clipperton, it was collected alive at locality B-6120 (40–45 meters) and dead at locality B-8558 (92 meters).

The genus *Neocaudites* has been characterized as a Caribbean taxon (McKenzie, 1967: 232). Previously, only one species had been reported from the Pacific basin, *N. terryi* from off the Hawaiian Islands on submarine terraces. Although *N. terryi* is generally

similar to *N. pacifica*, its surface ornamentation is smooth rather than reticulate or pitted.

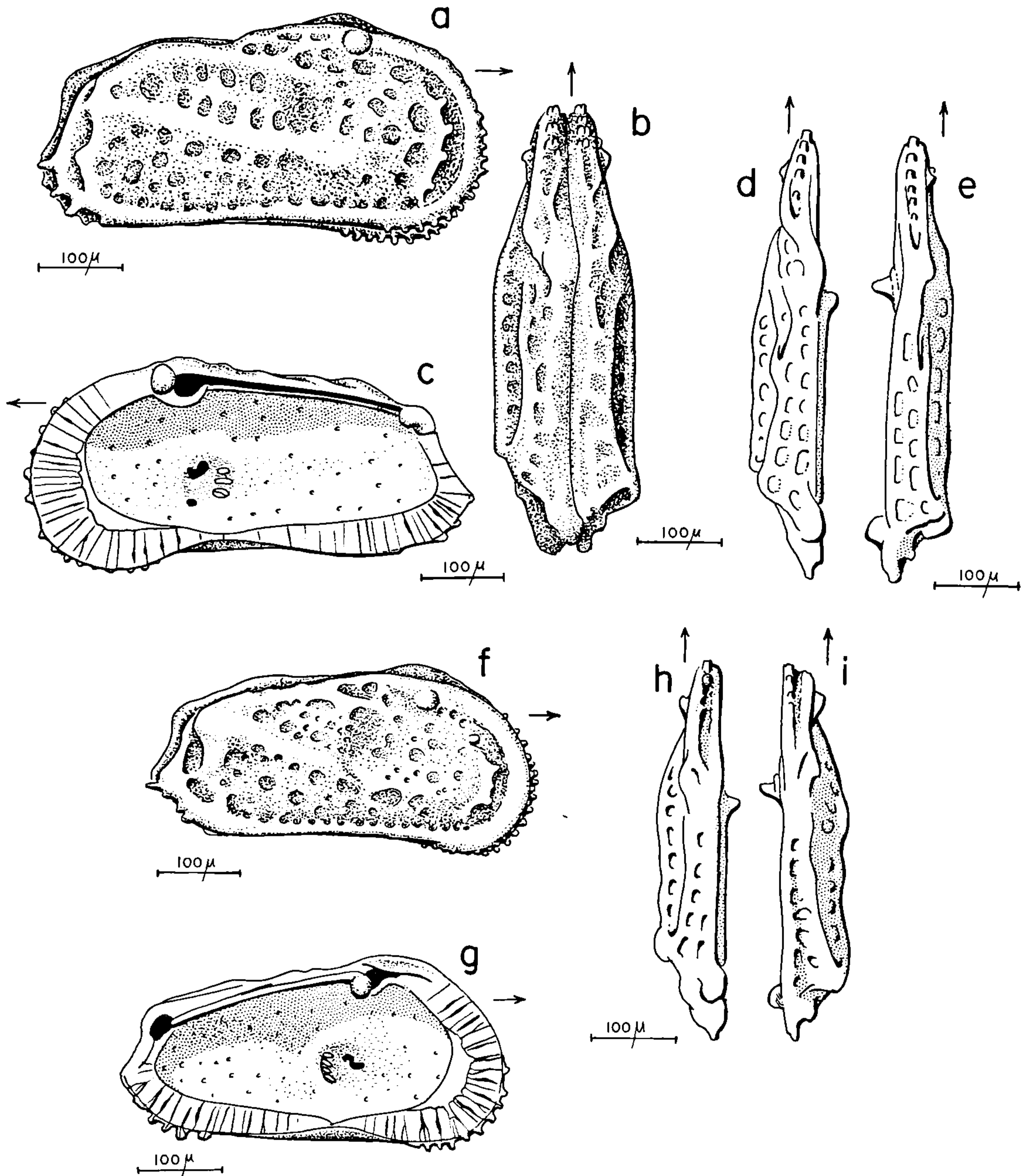

Figure 26. *Neocaudites pacifica* sp. nov. a-c, holotype, USNM 128117; a, external right valve view of adult male carapace; b, dorsal view; c, internal view of right valve. d-e, paratype, SDNH 04239; d, dorsal view of adult male left valve; e, dorsal view of right valve. *Neocaudites pacifica minima* subsp. nov. f, holotype, USNM 128120; external right valve view of adult female carapace; g-i, paratype, SDNH 04243; g, internal view of adult male left valve; h, dorsal view of left valve; i, dorsal view of right valve.

Genus *Occultocythereis* Howe, 1951
Occultocythereis angusta Bold, 1963

Figure 27

Cythereis deformis Brady, 1911: 597, pl. 20, figs. 7-8; not *Cythereis deformis* Baird, 1850: 256, pl. 18, figs. 4-6.
Occultocythereis angusta Bold, 1963: 391, pl. 9, figs. 1a-c, pl. 12, fig. 6 new name for *Cythereis deformis* Brady.

Diagnosis. — *Occultocythereis* with posterodorsal tubercle and posteroventral marginal rim heavy; dorsal rim weakly developed; lateral surface ornamentation very weakly developed; dorsal margin concave as seen from the side.

Description.— In side view: carapace small, length $450\ \mu$; length/height ratio = 2.0; highest point at anterocardinal angle in anterior third at midlength; dorsal margin straight between elevated cardinal angles; ventral margin straight or slightly irregular; anterior margin evenly and broadly rounded, with several well-developed denticles; larger left valve over-reaching right valve along venter, posterior, and at anterocardinal hinge angle; left valve asymmetric with elongate flange extending beneath valve along posteroventer margin; broad, flattened anterior marginal rim continuous from poorly developed eye tubercle to ventral inturned area; posteroventral area with complex massive tubercles; postero-cardinal angle occupied by large dimpled tubercle; valves conspicuously sulcate at midlength; surfaces generally smooth between narrow, inconspicuous, serpentine ridges in lateral areas. In dorsal view: greatest width in posterior third at ridge juncture terminating in small, posteriorly pointing, lateral spine, anterior bluntly pointed due to thick anteromarginal rim; posterior compressed behind postero-cardinal tubercles.

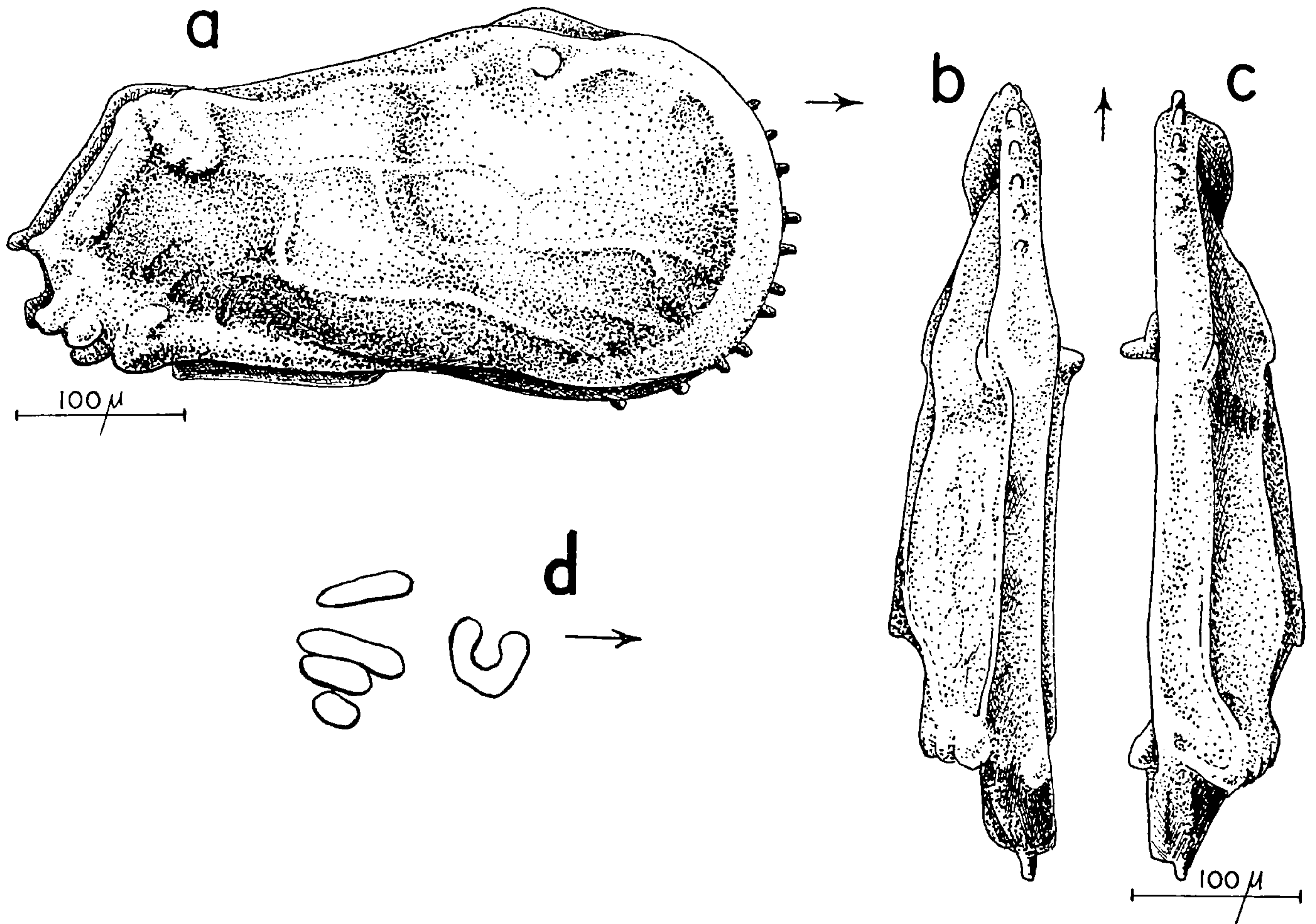

Figure 27. *Occultocythereis angusta* Bold, 1963. a-d, hypotype, USNM 128081; a, lateral right valve view of carapace; b, dorsal view of adult left valve; c, dorsal view of adult right valve; d, adductor muscle scar pattern of left valve.

Duplication of moderate width; vestibulae well developed, line of concrescence irregular and forming pockets into fused zone from which emanate straight, simple, abundant radial pore canals, about 30 in anterior; normal pores large, sparse, sieve type. Muscle scar pattern as shown in Figure 27d.

Dimensions.—

Hypotype, USNM 128081. Adult carapace, sta. B-6120

Length	Height	Width
461	229	183

Discussion.— *Occultocythereis angusta* is distinctive by the combination of features noted in the diagnosis. The dorsal ridge and lateral surface ornamentation is subdued, like that of

THIS PAGE IS LOCKED TO FREE MEMBERS
Purchase full membership to immediately unlock this page

FORGOTTEN BOOKS

FULL MEMBERSHIP

797,885 Books!
All you can read
for only
\$8.99/month

Continue

*Fair usage policy applies



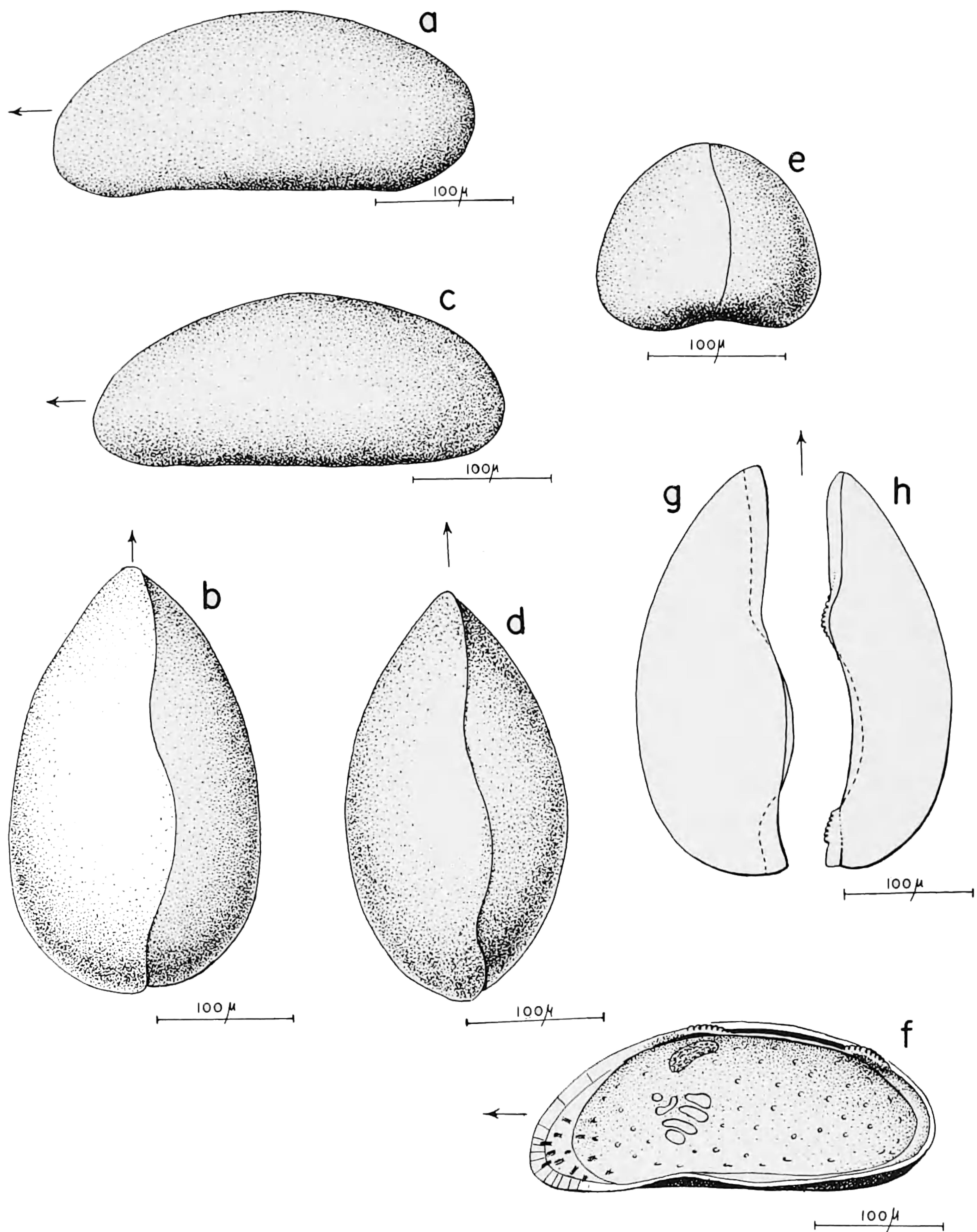

Figure 28. *Xestoleberis gracilis* Brady, 1890. a-b, hypotype, USNM 128082; a, left valve view of adult female carapace; b, dorsal view of adult female carapace. c-e, hypotype, USNM 128083; c, left valve view of adult male carapace; d, dorsal view of adult male carapace; e, anterior view of adult male carapace. f-h, hypotype, SDNH 04245; f, interior view of adult female right valve; g, dorsal view of adult female left valve; h, dorsal view of adult female right valve.

morphism not observed. In side view: valves suboblong, broadly rounded in outline, dorsal margin sloping slightly anteriorly; ventral margin straight; anterior and posterior margins bluntly rounded; carapace moderately compressed laterally, greatest inflation in ventral third; surfaces smooth. In dorsal view: carapace oblong, anterior and posterior bluntly rounded; greatest width at midlength.

Posterior duplicature narrow, entirely fused; anterior duplicature of moderate width, vestibulate. Radial pore canals simple, straight, equally spaced, numbering 20 in anterior, about 20 in posterior. Hinge typical for genus: smooth median bar of left valve almost straight as seen from above. Adductor muscle scar pattern a small vertical row of four elongate scars; single frontal scar directly anterior to topmost adductor scar.

Dimensions.—

	<i>Length</i>	<i>Height</i>	<i>Width</i>
Specimen, USNM 128085. Adult left valve, sta. B-6120	302	164	86
Specimen, SDNH 04244. Adult carapace, sta. B-6120	305	169	114
Specimen, USNM 128086. Adult left valve, sta. B-6120	300	164	82

Discussion.— The Clipperton Island specimens resemble *Xestoleberis* sp. cf. *X. eulitoralis* from Scammons Lagoon, Baja California, Mexico, more than they do the species from El Salvador which has no vestibule and has relatively complex radial pore canals. More and better preserved material would probably show this species to be conspecific to at least those from Scammons Lagoon.

At El Salvador *Xestoleberis eulitoralis* was found in the intertidal zone of Mejanguera Island, Gulf of Fonseca among rocks with corals, encrusting algae, barnacles, and oysters. McKenzie and Swain report their species occurring throughout Scammons Lagoon from 4 to 75 feet. At Clipperton Island three disarticulated valves were found at B-6120 (40–45 meters) and one at B-8558 (92 meters).

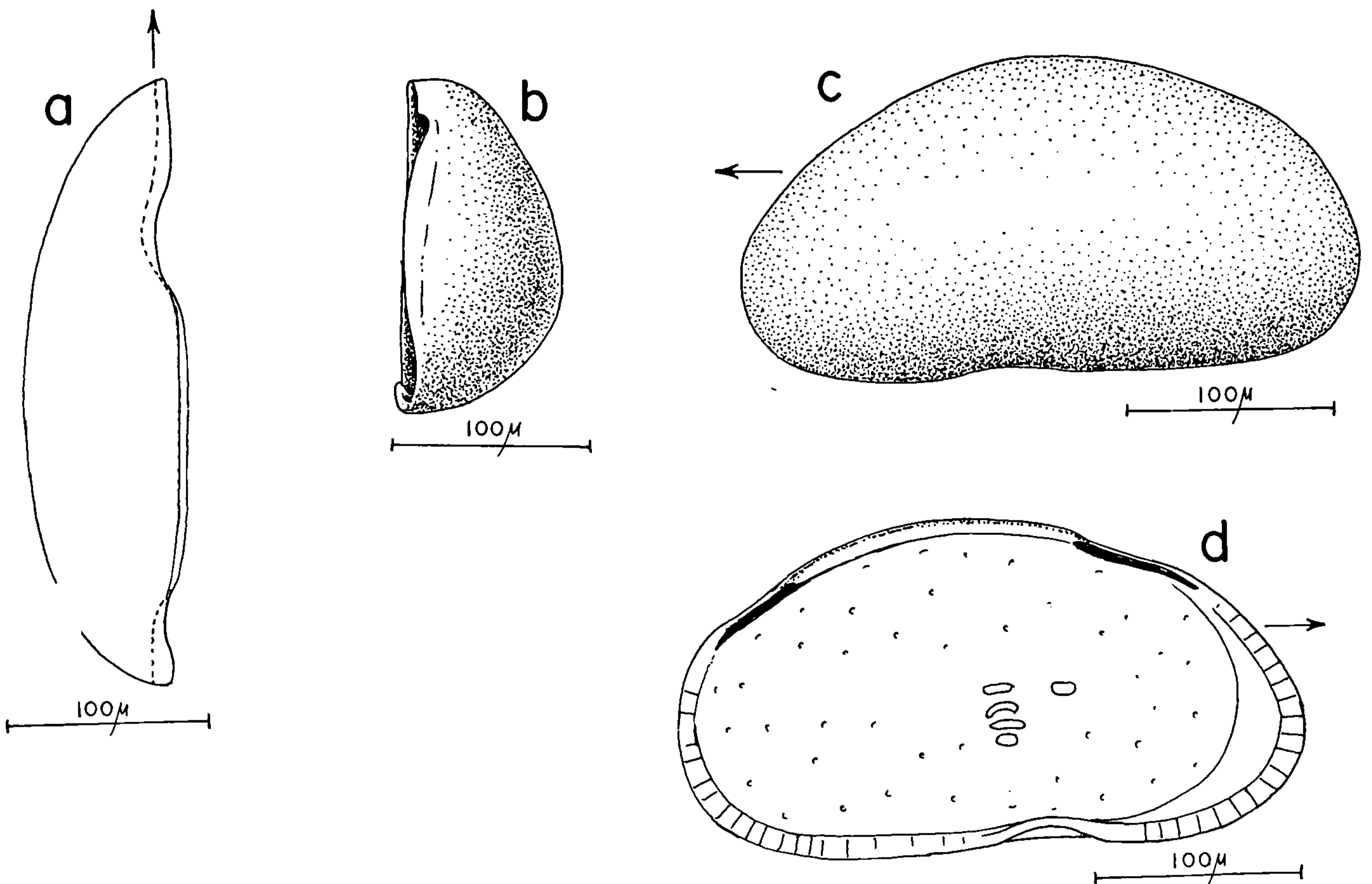

Figure 29. *Xestoleberis* sp. aff. *X. eulitoralis* Hartmann, 1959. a-d, specimen, USNM 128085; a, dorsal view of adult left valve; b, anterior view of adult left valve; c, lateral view of adult left valve; d, interior view of adult left valve.

Genus Uncertain

"*Cythere*" cf. "*C.*" *caudata* Brady, 1890

Figure 30

Description.— In side view: carapace elongate, length/height ratio=2.5; dorsal margin parallel to ventral margin throughout most of length; anterior margin broadly rounded; posterior with large compressed, bluntly pointed caudal process most of which lies beneath midheight. Shell ornamented with about 10 continuous and discontinuous glassy horizon-

tal ridges tending to parallel anterior margin. Caudal process and adjoining compressed parts of carapace smooth. In dorsal view: anterior sharply pointed; carapace midhalf parallel sided; posterior convex to highly compressed; caudal process of extreme posterior.

Internal features not observed.

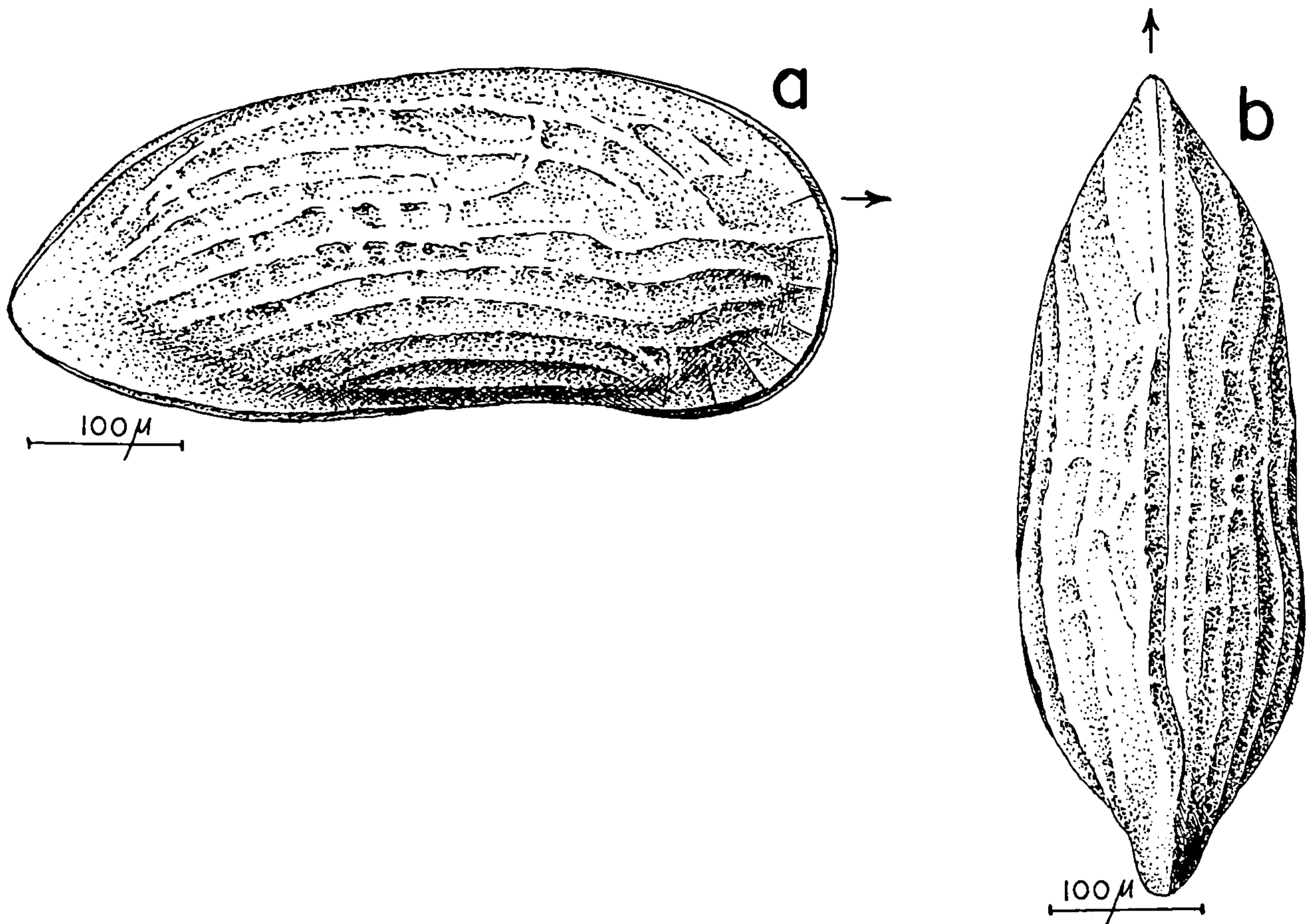

Figure 30. "*Cythere*" sp. cf. "*C.*" *caudata* Brady, 1890. a-b, specimen, USNM 128087; a, right valve view of adult(?) carapace; b, dorsal view.

Dimensions.—

Specimen, USNM 128087. Entire specimen, sta. 8558

<i>Length</i>	<i>Height</i>	<i>Width</i>
540	230	180

Discussion.— Only one specimen was collected by the carousel dredge at 92 m. The species closely resembles *Cythere caudata* Brady, 1890 from Sava, Sava Bay, Fiji, and "*Cythere*" *caudata* from Manila (Keij, 1954) and Hawaii (Holden, 1967). The single entire carapace from Clipperton Island is larger than those mentioned above. Brady's and Keij's species are 460 μ and 450 μ respectively. The ones from Hawaii come from two populations, one fossil with an individual 410 μ in length and one from Hanauma Bay with very small adult individuals only 350 μ long. The Clipperton Island form is distinctive with well developed horizontal ridge ornamentation, the elongate reticulae characteristic of the other related forms being defined between ridges. At the present time it is not possible to determine the specific relationships between the Clipperton forms and those described by other authors. All of the above species belong to an undescribed genus.

Suborder Platycopina Sars, 1866
 Family Cytherelloidea Sars, 1866
 Genus *Cytherelloidea* Alexander, 1929

THIS PAGE IS LOCKED TO FREE MEMBERS
Purchase full membership to immediately unlock this page

DELVE INTO FANTASY, MAGIC, MYTHOLOGY & FOLKLORE

Forgotten Books'
Full Membership gives
access to 797,885 ancient
and modern, fiction and
non-fiction books.

Continue

*Fair usage policy applies

pronounced and deep behind strong anterior rim in left valve; broad undulating sulci in dorsolateral and posterolateral areas, resulting in three ridge-like swellings along dorsum, venter, and from posterior cardinal angle to center of valve beneath prominent circular dorsocentral depression corresponding to internal adductor muscle scar swelling. Two circular swellings in posterior quarter of female carapace. Right valve larger, overlapping left valve around all margins. In dorsal view: female carapace lanceolate with greatest width at truncate posterior; right valve strongly overlapping left valve just anterior to midlength with large flange-like external tooth.

Anterior duplicature broad for genus, about $40\ \mu$ at widest point, fused; 15–18 evenly spaced, simple, anterior radial pore canals passing through marginal denticles. Hinge of left valve with large flattened tooth just posterior to midlength; right valve with corresponding "socket." About 11 oblong adductor muscle scars in typical *Cytherelloidea* pattern on broad swelling in dorsal half of carapace at midlength.

Dimensions.— The collection consists of eight adult specimens of which six were entire. Lengths range from 522 to 550 μ with an average of 535 μ ; heights range from 297 to 314 μ with an average of 308 μ ; widths range from 189 to 228 μ with an average of 211 μ .

	<i>Length</i>	<i>Height</i>	<i>Width</i>
Hypotype USNM 128088. Adult left valve, sta. B-6120	538	300	189
Hypotype, USNM 128088. Adult right valve, sta. B-6120	538	304	189
Hypotype, SDNH 04248. Adult carapace, sta. B-6120	540	309	215
Hypotype, SDNH 04249. Adult carapace, sta. B-6120	533	297	209
Hypotype, SDNH 04250. Adult carapace, sta. B-6120	550	313	228
Hypotype, SDNH 04251. Penultimate carapace, sta. B-6120	477	266	156
Hypotype, SDNH 04252. Penultimate carapace, sta. B-6120	482	275	152
Hypotype, SDNH 04253. Penultimate carapace, sta. B-6120	484	273	158

Discussion.— Small differences can be noted between the Clipperton Island forms of *Cytherelloidea praecipua* and those described by Bold (1963) from Tobago and Trinidad. Bold's illustrations of the species show a more arched dorsum and concave downward venter. In addition, the left valve hinge tooth appears smaller. In all other aspects the Clipperton Island forms seem identical to those from the Caribbean.

ACKNOWLEDGEMENTS

We would like to thank W. A. van den Bold, Louisiana State University, for information concerning the relationship of our fauna to those of middle America, and J. Teeter, University of Akron, who made unpublished information available. Arnold Ross and J. R. Jehl, Jr., San Diego Natural History Museum, read the final manuscript and offered many helpful suggestions. The laboratory work and manuscript preparation, largely completed at San Diego State College during the summer of 1968, have received partial support from the National Science Foundation through Grant GA-1403. This paper is a contribution from the Scripps Institution of Oceanography, University of California, San Diego, California.

LITERATURE CITED

Alexander, C. I.

1929. Ostracoda of the Cretaceous of North Texas: Texas Univ. Bull. 2907, 137 p. 10 pls.

Apostolescu, V.

1967. Détermination des ostracodes de la Mission Singer-Polignac en Nouvelle-Calédonie: Editions de la Found. Singer-Polignac, Paris, p. 121-125, 2 pl.

Baird, W.

1849. Arrangement of the British Entomostraca, with a list of species, particularly noticing those which have as yet been discovered within the bounds of the Club: Berwickshire Nat. Club (Hist.) Proc. (1842-1849), 2: 145-158.

1850. The natural history of the British Entomostraca. Roy Soc. London, p. i-viii, 1-366, 36 pls.
- Belcher, E.
1843. Narrative of a voyage round the world, performed in Her Majesty's Ship "Sulphur" during the years 1836-1842. . . . Vol. 1. Colburn, London, 387 (vol. 1) and 474 (vol. 2) pp.
- Benson, R. H.
1959. Ecology of Recent ostracodes of the Todos Santos Bay region, Baja California, Mexico: Univ. Kansas Paleont. Contr., Arthropoda, art. 1:1-80, 11 pl., 20 figs.
1964. Recent marine Podocopid and Platycopid ostracodes of the Pacific: Pubbl. Staz. zool. Napoli 33, suppl.: 387-420.
- Benson, R. H. and G. L. Coleman, II
1963. Recent marine ostracodes from the eastern Gulf of Mexico: Univ. Kansas Paleont. Contr., Arthropoda, art. 2: 1-52.
- Benson, R. H. and R. L. Kaesler
1963. Recent marine and lagoonal ostracodes from the Estero de Tastiota region, Sonora, Mexico (Northeastern Gulf of California): Univ. Kansas Paleont. Contr., Arthropoda, art. 3: 1-34.
- Bold, W. A. v. d.
1946. Contribution to the study of Ostracoda with special reference to the Tertiary and Cretaceous microfauna of the Caribbean region. Diss. Univ. Utrecht, Amsterdam, 167 p., 18 pl.
1957. Oligo-Miocene Ostracoda from southern Trinidad. Micropaleontology 3: 231-254, 4 pl., 2 figs.
1963. Upper Miocene and Pliocene Ostracoda of Trinidad. Micropaleontology 9: 361-424, 12 pl.
1966. Ostracoda from Colon Harbour, Panama. Caribbean Jour. Sci. 6(1-2): 43-64, 5 pl.
- Brady, G. S.
1866. On new or imperfectly known species of marine Ostracoda. Zool. Soc. London, Trans. 5: 359-391, pls. 57-62.
1868. A monograph of the Recent British Ostracoda. Trans. Linn. Soc., London 26: 353-495, pls. 23-41.
1870. Notes on Entomostraca taken chiefly in the Northumberland and Durham District (1869) Trans. Soc. Nat. Hist. Northumberland Durham 3: 361-373.
1880. Report on the Ostracoda dredged by the H.M.S. *Challenger* during the years 1873-1876. Rept. Voyage *Challenger*, Zool. 1 (3): 1-184, pls. 1-44.
1890. On the Ostracoda collected by G. S. Brady in the South-Sea Islands. Trans. Roy. Soc. Edinburgh 35: 489-525, 4 pl.
1911. Notes on marine Ostracoda from Madeira. Proc. Zool. Soc. London 2: 595-601, pls. 20-22.
- Brady, G. S. and A. M. Norman
1889. A monograph of the marine and freshwater Ostracoda of the North Atlantic and northwestern Europe: Sect. 1. Podocopida. Trans. Roy. Dublin Soc. Sci., ser. 2, 4: 63-270, pls. 8-23.
- Briggs, J. C.
1961. The East Pacific Barrier and the distribution of marine shore fishes. Evolution 15: 545-554, 3 text fig.
- Crouch, R. W.
1949. Pliocene Ostracoda from Southern California. J. Paleon. 23: 594-599, pl. 96.
- Durham, J. W. and E. C. Allison
1960. The geologic history of Baja California and its marine faunas. Syst. Zool. 9 (2): 47-91, 7 text figs., 9 tables.
- Egger, J. G.
1901. Ostracoden aus Meeresgrund-Proben gelothet von 1874-1876 von S.M.S. Gazelle. Abh. Math-Phys. Kl. K. Bayerische Akad. Wiss. 21: 413-478, 8 pl.
- Ekman, S. P.
1953. Zoogeography of the Sea (translated from Swedish by Elizabeth Parker). Sedgwick and Jackson, London, XIV, 417 p.
- Emerson, W. K.
1967. Indo-Pacific faunal elements in the tropical eastern Pacific, with special reference to the mollusks. Venus 25: 85-93 text fig. 1
- Fergusson, G. J. and W. F. Libby
1962. UCLA radiocarbon dates I. Radiocarbon 4: 109-114.
- Fischer, S.
1855. Beiträge zur kenntnis der Ostracoden. Abh. Math.-Phys. Kl. K. Bayerische Akad. 7(3): 637-666, pls. 19-20.
- Gunther, F. J.
1967. Ostracoda of the Gulf of Panama and Bahia San Miguel. Univ. Minnesota M.S. Thesis, 204 p., 8 pl.
- Guha, D. K.
1968. On the Ostracoda from Neogene of Andaman Islands. J. Geol. Soc. India 9: 58-66, pls. 4-5.

Hanai, T.

1957. Studies in the Ostracoda from Japan: 3, subfamilies Cytherurinae G. W. Müller (emend. G. O. Sars, 1925) and Cytheroplerinae n. subfam. J. Tokyo Univ. Fac. Sci., sec. 2(11): 11-36, pls. 2-4, 9 figs.

Hartmann, G.

1953. *Iliocythere meyer-abichi* nov. spec., ein ostracodes des Schlickwattes von San Salvador. Zool. Anz. 151: 310-316.
1956. Zur Kenntnis des Mangrove-Estero-Gebeites von El Salvador und seiner Ostracoden-fauna. Kieler Meeresforsch. 12: 219-248.
- 1957a. Zur Kenntnis des Mangrove-Estero-Gebeites von El Salvador und seiner Ostracoden-fauna. II. Kieler Meeresforsch. 13: 134-159, pls. 39-50.
- 1957b. Contribucion al conocimiento de la region de estero y manglar de el Salvador y sua fauna de ostracodos, la Parte Ecologia, 2a. Parte sistematica. Sobretiro Rev. Comun. Inst. Trop. Invest. Cient. Univ. El Salvador 6: 47-108, 6 pl.
- 1959a. Beitrage zur Kenntnis des Nicaragua-Sees unter besonderer Berücksichtigung seiner Ostracoden (mit Beschreibung von 5 neuen Arten). Zool. Anz. 162: 269-294, 9 figs.
- 1959b. Zur Kenntnis der lotischen Lebensbereiche der pazifischen Kuste von El Salvador unter besonderer Berücksichtigung seiner Ostracoden fauna, 3, Beitrag zur Fauna el Salvador. Kieler Meeresforsch. 15: 187-241, pls. 27-48.

Hertlein, Leo G.

1937. A note on some species of marine mollusks occurring in both Polynesia and the Western Americas. Amer. Philos. Soc. Proc. 78 (2): 303-312, pl. 1, map.

Hertlein, Leo G. and William K. Emerson

1953. Mollusks from Clipperton Island (eastern Pacific) with the description of a new species of gastropod. San Diego Soc. Nat. Hist., Trans. 11 (13): 345-364, pl. 26-27.

Hinte, J. E. Van

1964. A new *Occultocythereis* species of the Austrian Eocene. K. Nederlandse Akad. Wetensch., ser. B, 62: 108-115, 5 figs.

Holden, J. C.

1964. Upper Cretaceous ostracods from California: Paleontology 7: 393-429, 28 figs.
1967. Late Cenozoic ostracodes from the drowned terraces in the Hawaiian Islands: Pacific Sci. 21: 1-50, 36 figs.

Howe, H. V.

1951. New Tertiary ostracode fauna from Levy County, Florida. Florida Geol. Surv. Bull. 34, 43 p., 5 pls.

Howe, H. V. and John Law

1936. Louisiana Vicksburg Oligocene Ostracoda. Dept. Conserv., Louisiana Geol. Bull. 7, 96 p., 6 pls.

Juday, C.

1907. Ostracoda of the San Diego region. II. Littoral forms. Univ. Calif. Publs., Zool. 3: 135-358, pls. 18-20.

Kaufmann, A.

1900. Zur Systematik der Cypriden. Mitt. Naturforsch. Ges. Bern.: 103-109.

Key, A. J.

1953. Preliminary note on the Recent Ostracoda of the Snellius Expedition: Koninkl. Nederlandse Akad. Wetensch. Amsterdam, ser. B, 56: 155-168, 2 pls.

Kingma, J. T.

1948. Contributions to the knowledge of the Young-Cenozoic Ostracoda from the Malayan region. Diss. Univ. Utrecht, Kemink Printers, Utrecht, 119 p., 11 pls.

Klie, W.

1938. Ostracoda, Muschelkresse. In, Dahl's Die Tierwelt Deutschland und der Angrenzenden Meeresteile, 34, 230 p.
1940. Beitrage zur Fauna der Eulitorals von Deutsch-Sudwest-Afrikas. Kieler Meeresforschungen 3: 404-448.

Kollmann, K.

1963. Ostracoden aus der alpinen Trias II. Weitere *Bairdiidae*. Jahrb. Geol. 106: 121-203, 11 pls.

Kornicker, L. S.

1961. Ecology and taxonomy of recent Bairdiinae (Ostracoda). Micropaleontology 7 (1): 55-70.

Le Roy, L. W.

1943. Pleistocene and Pliocene Ostracoda of the coastal region of Southern California. J. Paleon. 17: 354-373, pls. 58-62.
1945. A contribution to ostracodal ontogeny. J. Paleon. 19: 81-86, pls. 1-25, figs. 1-2.

THIS PAGE IS LOCKED TO FREE MEMBERS
Purchase full membership to immediately unlock this page

FORGOTTEN BOOKS

FULL MEMBERSHIP

797,885 Books!
All you can read
for only
\$8.99/month

Continue

*Fair usage policy applies



- of twenty-one new species. *Occas. Papers, California Acad. Sci.* 15: 1-144.
1950. Two new species of marine Ostracoda (Podocopa) from California: *Proc. California Acad. Sci., ser. 4*, 26: 483-505, pls. 27-30.
- Sverdrup, H. V., Martin W. Johnson, and Richard H. Fleming
1942. *The oceans, their physics, chemistry, and general biology*. Prentice-Hall, Inc., x + 1027 p.
- Swain, M.
1967. Ostracoda from the Gulf of California. *Geol. Soc. America, Memoir* 101, 139 p.
- Swain, M. and J. M. Gilby
1964. Ecology and taxonomy of Ostracoda and an alga from Lake Nicaragua. *Pubbl. Staz. zool. Napoli* 33 (suppl.): 361-386, 4 pls.
- Swain, W. and F. J. Gunther
1969. Recent ostracoda from San Juan del Sur, Nicaragua, and their relationship to other ostracode populations of western Central America. *Inst. Centroamericano Invest. Tech. Indust. (Guatemala, C. A.), Trabcijos Technicos Presentados en la segundo Reunion de Geologos de America Central Publ. Geol. I.C.A.I.T.I.* 2: 54-55, 1 table (abst.).
- Sylvester-Bradley, P. C.
1948. The ostracode genus *Cythereis*. *J. Paleont.* 22(6): 792-797, pl. 122.
- Teeter, W. T.
1966. The distribution of Recent marine ostracodes from British Honduras. Ph.D. thesis, Rice University, Houston, Texas, 212 p., 19 pls.
- Tressler, W. L.
1941. Ostracoda, part 4, of *Geology and Biology of North Atlantic deep-sea cores between Newfoundland and Ireland*. U.S. Geol. Surv. Prof. Paper 196-C: 95-106, pls. 18-19.
- Triebel, E.
1948. Zur Kenntnis der Ostracoden-Gattung *Triebelina*. *Senckenbergiana* 29: 17-22.
1954. *Loxoconchella* n. g. (Crust., ostr.): *Senckenbergiana Lethaea* 35: 17-21, 2 pls.
1956. Brackwasser-ostracoden von den Galapagos-Inseln: *Senckenbergiana Biol.* 37: 447-467, pls. 54-58.
1957. Neue Ostracoden aus dem Pleistozan von Kalifornien: *Senckenbergiana Lethaea* 38: 291-309, pls. 1-5.
1960. Die taxonomische Stellung und die Gattungen der Unterfamilie Macrocypridinae (Ostracoda): *Senckenbergiana Biol.* 44: 109-124, pls. 13-20.
1961. Geschlechts-dimorphismus und asymmetrie der klappen bei der ostracodengattung *Occultocythereis*: *Senckenbergiana Lethaea* 42: 205-225, 5 pls.
- U. S. Navy Hydrographic Office
1947. Atlas of surface currents, northeastern Pacific Ocean. Hydrographic Office Publ. 570, 12 sheets.
1950. Atlas of surface currents, northwestern Pacific Ocean. Hydrographic Office Publ. 569, 12 sheets.
1966. Atlas of pilot charts, South Pacific and Indian Oceans, Third Edition. Hydrographic Publ. 107.
- Wagner, C. W.
1957. Sur les ostracodes du quaternaire recent des Pas-Bas et leur utilisation dans l'etude geologique des deposts holocenes. Mouton and Co., The Hague, 158 p. 40 pls.
- Wyrтки, K.
1965. Oceanography of the eastern equatorial Pacific Ocean. *Oceanogr. Mar. Biol. Ann. Rev.* 4: 33-68.

Department of Geology, San Diego State College, San Diego, California 92115, and National Oceanic and Atmospheric Administration, Atlantic Oceanographic and Meteorological Laboratories, 901 South Miami Avenue, Miami, Florida 33130

**STUDIES ON THE TETRACLITIDAE
(CIRRIPIEDIA: THORACICA)
A NEW TETRACLITELLAN FROM INDIA**

ARNOLD ROSS

TRANSACTIONS

**OF THE SAN DIEGO
SOCIETY OF
NATURAL HISTORY**

VOL. 16, NO. 8 21 MAY 1971

THIS PAGE IS LOCKED TO FREE MEMBERS
Purchase full membership to immediately unlock this page

DELVE INTO FANTASY, MAGIC, MYTHOLOGY & FOLKLORE

Forgotten Books'
Full Membership gives
access to 797,885 ancient
and modern, fiction and
non-fiction books.

Continue

*Fair usage policy applies

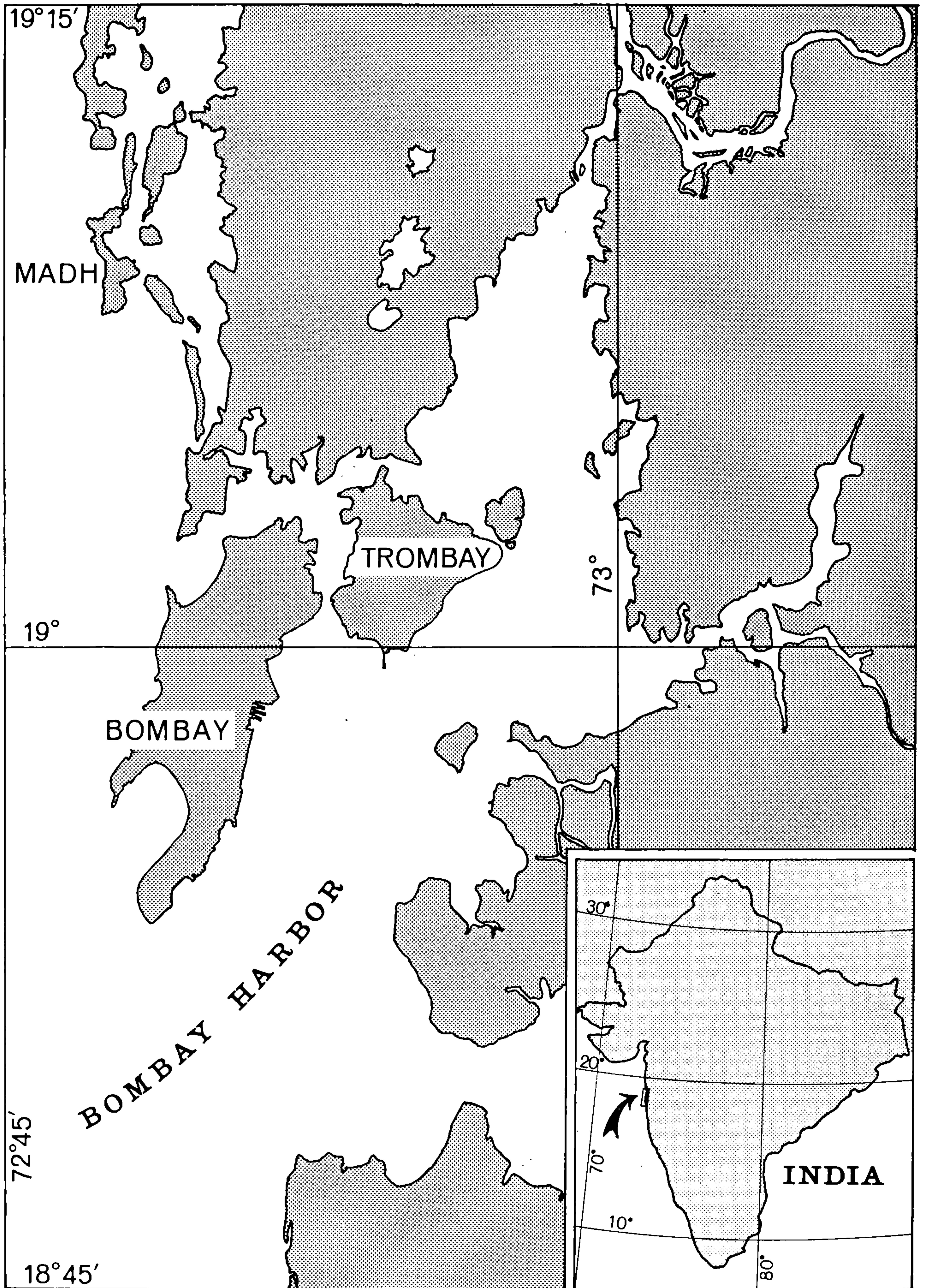

Figure 1. Map showing position of Mad'h Island relative to other islands along the Bombay coast of India.

Type species.—*Lepas purpurascens* Wood (1815: 55), Recent, Australia, by original designation of Hiro (1939: 273).

Remarks.—Hiro (1939: 273) established *Tetraclitella* as a subgenus of *Tetraclita*. Recently, in reevaluating the tetraclitids I raised the subfamily to familial status (Ross, 1968: 6), and accordingly the subgenera of *Tetraclita* were raised to genera to better reflect relationships within the family (Ross, 1969: 237; Ross, 1970: 3). Utinomi (1970: 349) independently also accorded *Tetraclitella* generic rank.

Species referable to *Tetraclitella* include: *T. purpurascens* (Wood, 1815: 55), *T. costata* (Darwin, 1854: 339), *T. chinensis* (Nilsson-Cantell, 1921: 359), *T. divisa* (Nilsson-Cantell, 1921: 362), *T. darwini* (Pilsbry, 1928: 314), *T. multicostata* (Nilsson-Cantell, 1930: 2) and *T. pilsbryi* (Utinomi, 1962: 234). *Tetraclita squamosa depressa* (Kolosvary, 1941: 42) from southern Australia, *Tetraclita purpurascens darwini* (Kolosvary, 1942: 140) from Port Jackson, New South Wales, Australia, and *Tetraclita radiata wagneri* (Kolosvary, in Kolosvary and Wagner, 1941: 11) from Tasmania, on the basis of morphology and biogeography, are apparently conspecific with *T. purpurascens purpurascens*.

KEY TO THE SPECIES OF *TETRACLITELLA*

1. Radii elevated above surface of parietes 2
1. Radii flush with or sunken below surface of parietes 3
2. Scutum higher than wide; intermediate segments of cirrus VI with 4 pairs of setae (Japan, Formosa) *T. darwini*
2. Scutum wider than high; intermediate segments of cirrus VI with 3 pairs of setae (India) *T. karandei*
3. Scutum higher than wide 4
3. Scutum wider than high 5
4. Scutum with a row of small longitudinal pits; intermediate segments of cirrus VI with 4 pairs of setae; basis calcareous (Lesser Sunda Islands, Sulu and Philippine Archipelagos) *T. costata*
4. Scutum with 5 rows of longitudinal pits; intermediate segments of cirrus VI with 3 pairs of setae; basis membranous (Japan) *T. pilsbryi*
5. Tergal spur essentially confluent with scutal margin 6
5. Tergal spur well separated from scutal margin (intermediate segments of cirrus VI with 3 pairs of setae; circumtropical) *T. divisa*
6. Parietal plates without hollows 7
6. Parietal plates pierced by hollows (intermediate segments or cirrus VI with 4, rarely 3 pairs of setae; southern China, Formosa, Japan) *T. chinensis*
7. Shell with 14 or fewer primary longitudinal ribs; cuticle persistent (West Irian, New Guinea) *T. multicostata*
7. Shell with 20 or more primary longitudinal ribs; cuticle not persistent (intermediate segments of cirrus VI with 2 pairs of setae; New Zealand, Tasmania, Australia, Malay Archipelago, India) *T. purpurascens*

***Tetraclitella karandei* n. sp.**

Diagnosis.—Radii transversely ridged, the apical 3-4 ridges extending like fingers out and over adjoining plate; scutum transversely elongated, externally ornamented with prominent nodes where longitudinal ridges cross growth lines; intermediate articles of posterior cirri armed with 3 pairs of setae.

Description.—Shell white or grayish white, patelliform, ovate in outline, covered with persistent, hirsute, chitinous cuticle; parietes ornamented with prominent growth ridges, and high, primary, longitudinal ribs intercalated with lower secondary and tertiary ribs; ribs square or T-shaped in section, extending from orifice to or beyond basal edge of shell, occasionally bifurcate basally (Fig. 2a, b); orifice diamond-shaped; radii broad, horizontally ridged from base to apex, the ridges becoming progressively higher, produced and free from the surface (Fig. 2a); articular margin and finger like projections tubiferous, the apertural margins of the tubes being crenate; on the adjoining plate a narrow, longitudinal ridge occurs on parietal surface where the radius butts against the plate (Fig. 2b); alae broad, summits horizontal and crenate; sheath less than $\frac{1}{2}$ height of wall, basal margin not depending; basis calcareous peripherally.

Scutum wider than high; external surface deeply sulcate (Fig. 2e); where the growth ridges are crossed by longitudinal ridges prominent nodes are formed thus rendering a scabrous appearance; articular ridge straight, about $\frac{2}{3}$ length of tergal margin; adductor ridge low, not undercut, apically fused with articular ridge, terminating basally at basi-occludent angle; adductor muscle depression ovate, shallow, borders poorly delimited; depression for lateral depressor muscle shallow, poorly defined; depression for rostral depressor muscle lacking; apical portion of plate with weak ridges (Fig. 2d).

Tergum higher than wide; external longitudinal furrow open, broad, shallow, extending to base of spur; spur evenly rounded basally, confluent with scutal margin, width about $\frac{1}{2}$ that of basal margin (Fig. 2g); articular ridge inclined; articular furrow wide and shallow; 6-7 crests for depressor muscle, low, short, inclined; apical portion of valve ridged or roughened (Fig. 2f).

Measurements of the holotype are as follows (in mm): rostro-carinal diameter 10.1; height 3.5; rostro-carinal diameter of orifice 3.6; height of scutum 1.5; width of scutum 2.1; height of tergum 1.5; width of tergum 1.0. The mean rostro-carinal diameter of five paratypes is 13.5 mm and the height is 3.8 mm.

Labrum with shallow, broad, medial depression; crest thick, heavily chitinized, armed with short, fine bristles but rarely with teeth (Fig. 3a). Palps long, broad, distal end broadly rounded; superior margin straight, basal margin convex; proximal setae on superior margin short, stout, coarsely bipectinate; distal setae on margin long, slender, finely bipinnate; basal portion of lateral surface covered with ctenae. Mandible with 5 unequally spaced teeth; teeth 2 and 3 commonly with 1-2 subsidiary cusps; tooth 4 with 3-5 subsidiary cusps; comb between tooth 5 and inferior angle containing 8-12 teeth; inferior angle commonly with 1 long, slender and 1 short, stout tooth (Fig. 4). Maxilla I with 2 long, stout and 1-2 shorter spines above sub-apical notch; 2-3 short, slender spines in notch; 6-8 stout spines medially; 8-12 short, slender spines in basal cluster (Fig. 3c). Maxilla II bilobate; setae along apical margin long; bipinnate, setae becoming progressively shorter toward the notch; setae on basal lobe coarse, bipectinate.

Posterior ramus of cirrus I about $\frac{3}{5}$ length of anterior ramus; intermediate articles of both rami broader than high; segments of anterior ramus normal, but those of posterior ramus protuberant; distal articles of both rami clothed with finely bipinnate setae (Fig. 3g). Rami of cirrus II essentially equal in length, and slightly longer than posterior ramus of cirrus I; medial segments of both rami protuberant; distal two segments of both rami armed with bipectinate setae, proximal segments with bipinnate setae (Fig. 3h). Rami of cirrus III of equal length, and same length as rami of cirrus II; medial segments of both rami protuberant; distal 2 or 3 segments of anterior ramus and all segments of posterior ramus armed with bipectinate setae (Fig. 3i). Cirri IV-VI essentially equal in length with equal rami; 1-2 stout spines and 2-3 long, slender setae at each articulation along greater

THIS PAGE IS LOCKED TO FREE MEMBERS
Purchase full membership to immediately unlock this page

FORGOTTEN BOOKS

FULL

MEMBERSHIP

797,885 Books!

All you can read

for only

\$8.99/month

Continue

*Fair usage policy applies



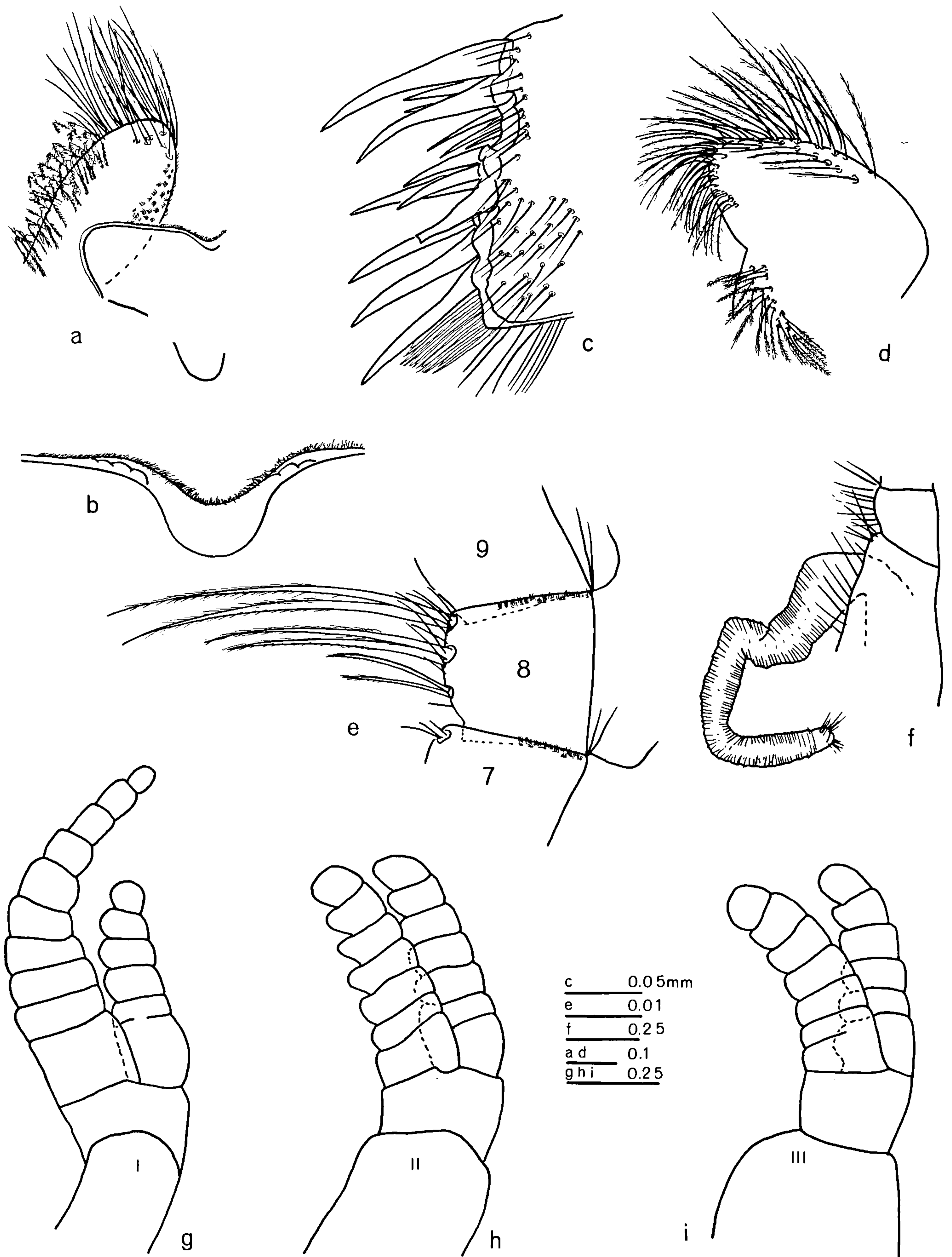

Figure 3. Trophi and cirri of *Tetracitella karandei* n. sp. a, labrum and palp; b, enlarged view of labrum; c, maxilla I; d, maxilla II; e, intermediate segments of outer ramus of cirrus VI; f, penis; g, cirrus I; h, cirrus II; i, cirrus III. Holotype (4000), c, f; paratypes, a-b, d-e, g-i (a, d = 4001/c; b = 4001/d; e, g-i = 4001/b).

curvature of intermediate segments; 1 or 2 rows of ctenae present on lateral face of intermediate segments immediately below articulation; setation ctenopod, with 3 pairs of setae on each intermediate segment, and commonly a single proximal, short seta; at base of and between each major pair of setae there is a cluster of 3-5 short, slender setae (Fig. 3e). Cirral counts for specimens in the type lot are summarized in Table 1.

Table 1. Summary of data on cirral counts: range (R) and mean (X) value for number of segments in anterior (a) and posterior (p) rami

	I		II		III		IV		V		VI	
	a	p	a	p	a	p	a	p	a	p	a	p
N	10	10	12	12	11	11	7	7	6	6	4	4
R	10-11	6-7	7-8	6-8	6-8	6-9	11-14	11-15	14-16	15-17	15-16	15-18
X	10.6	6.3	7.3	7.1	7.1	6.2	12.8	14.0	15.0	15.2	15.5	16.7

Intromittent organ annulated throughout its length, and sparsely covered with short, slender bristles; distal extremity with 4 clusters of 11-14 setules (Fig. 3f).

Remarks.—Of the presently recognized tetracelitellans, *T. karandei* may be distinguished by its radii, which have raised digitiform processes that extend out and over the adjoining plates. The shape of the tergum in *karandei* is similar to that found in *multicostata*, *purpurascens* and *chinensis*, but the scutum of this species has a scabrous or nodose ornamentation externally rather than only simple growth ridges. The mandible of *karandei* appears to be more variable than any other species in the degree of development and number of subsidiary cusps on the second, third, and fourth teeth (see Fig. 4). The crest of the labrum is commonly devoid of teeth as it is in *purpurascens*, *costata* and *darwini*. But when teeth are developed, they appear as simple, low, rounded knobs, that are few in number. The mouth parts and appendages have not been described for *pilsbryi*.

Disposition of types.—The holotype and four paratypes are housed in the collections of the San Diego Society of Natural History, Marine Invertebrate catalogue numbers 4000 and 4001, respectively. Two paratypes are in the collections of the Zoological Survey of India, Calcutta. The remaining specimens have been retained by the author.

Type locality.—Mad'h Island, Bombay Coast, India, approximately 19°8'N., 72°47'22"E.; A. A. Karande coll. 1969; 10 specimens.

Comparative material.—I have examined specimens of the following species:

T. divisa: western side of Panto Hole Bay, east of town of Marigot, Dominica; approximately 15°32'21"N., 61°17'31"W., intertidal on *Tetracelita stalactifera* (Lamarck); E. Kirsteuer and K. Rützler coll.; 1-10 May 1966 (see Ross, 1968:13).

T. chinensis: Suô (Suao), Taiwan, approximately 24°35'45"N., 121°51'10"E., "... on sheltered undersurface of stones in the littoral"; F. Hiro coll., 30 May 1938 (see Hiro, 1939: 277).

T. purpurascens: Eddystone Point, Tasmania, approximately 40°59'30"S., 148°20'E.; I. Bennett coll., 20 June 1964. The Nobbies, Phillip Island, Victoria, Australia, approximately 38°30'S., 145°16'E.; E. C. Pope coll., May 1949. Little Papanui, Otago Peninsula, South Island, New Zealand, approximately 45°50'S., 170°43'E.; C. Hand coll., 4 November 1959.

T. darwini: Isle Hatake-zima, Tanabe Bay, Wakayama Prefecture, Japan, approximately 33°43' N., 125°21'30" E.; F. Hiro coll., 3 April 1928.

Etymology.—The specific epithet honors Dr. Ashok A. Karande, Senior Science Officer, Naval Chemical and Metallurgical Laboratory, Bombay, India, who collected the specimens.

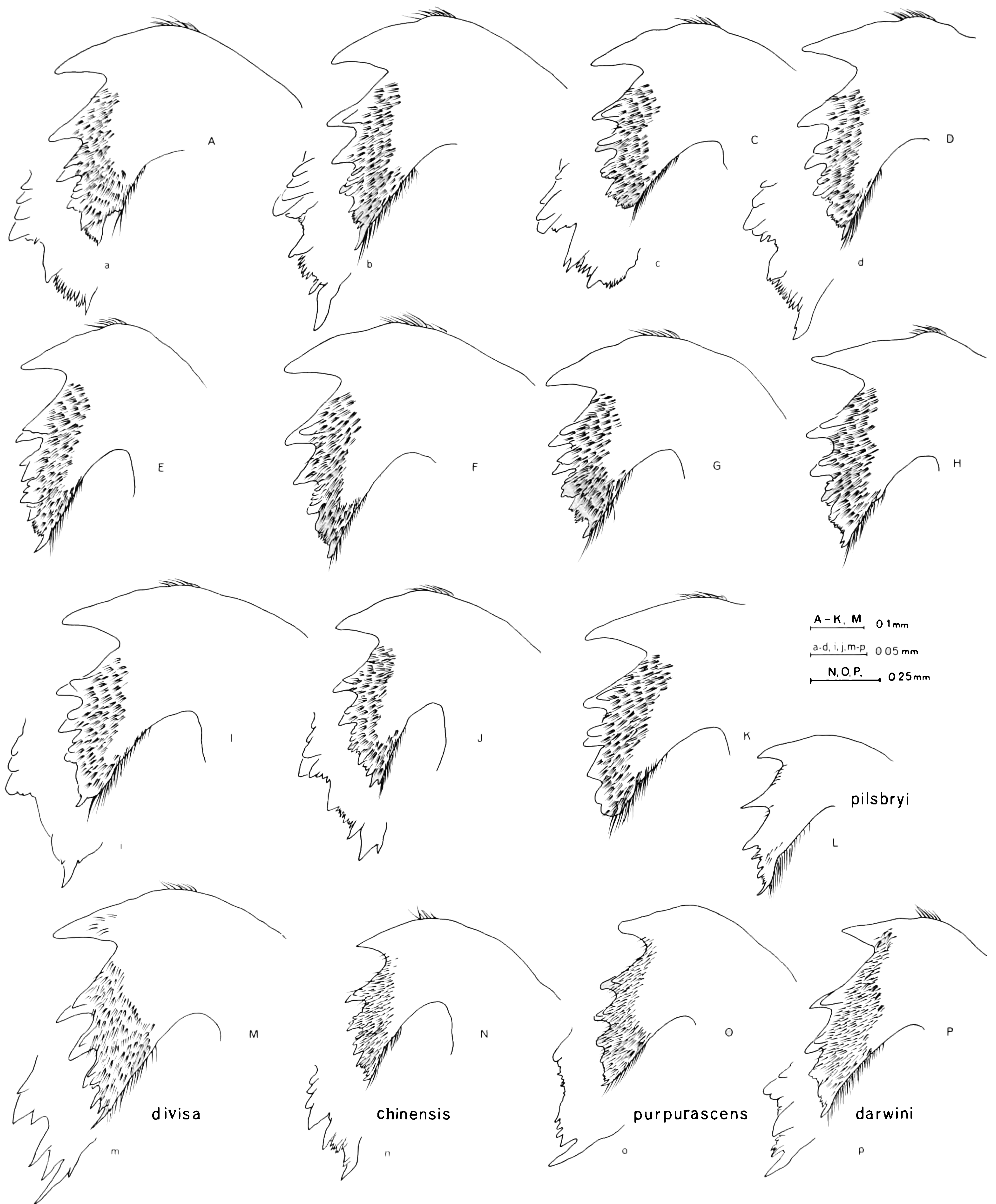

Figure 4. Mandibles of *Tetracitella karandei* n. sp. and related tetracitellans. A, E, right and left, respectively, holotype (4000); B, F, right and left, respectively, paratype 4001/b; C, G, right and left, respectively, paratype 4001/c; D, H, right and left, respectively, paratype 4001/d; I, K, right and left, respectively, paratype 4001/e; J, right, paratype, Zool. Survey India; L, after Utinomi, 1962; M, from Dominica; N, from Taiwan; O, from Tasmania; P, from Japan.

THIS PAGE IS LOCKED TO FREE MEMBERS
Purchase full membership to immediately unlock this page

DELVE INTO FANTASY, MAGIC, MYTHOLOGY & FOLKLORE

Forgotten Books'
Full Membership gives
access to 797,885 ancient
and modern, fiction and
non-fiction books.

Continue

*Fair usage policy applies

Australian Museum, Huzio Utinomi, Seto Marine Biological Laboratory, Brian Foster, Auckland University, William A. Newman, Scripps Institution of Oceanography and Ernst Kirsteuer, American Museum of Natural History, for their help in providing me with comparative material. Anne Acevedo prepared figures 1 and 2.

LITERATURE CITED

- Darwin, C. R.
1854. A monograph on the sub-class Cirripedia. The Balanidae, the Verrucidae, etc. London, Ray Society, 684 p.
- Hiro, F.
1939. Studies on the cirripedian fauna of Japan. IV. Cirripeds of Formosa (Taiwan) with some geographical and ecological remarks on the littoral forms. Mem. Coll. Sci. Kyoto Imp. Univ. ser. B, 15(2): 245-284.
- Karande, A. A.
1966. The sessile barnacles (Cirripedia) of the Bombay Coast. J. Bombay Nat. Hist. Soc. 63(1): 139-151.
- Kolosváry, G.
1941. Balaniden-Studien. Zool. Anz. 135(1/2): 41-45.
1942. Studien an cirripedian. Zool. Anz. 137(7/8): 138-150.
- Kolosváry, G. and J. Wagner
1941. Tengerbiológiai tanulmány a kacslábúak, puhatestűek és korallok társulásáról. A Tenger 31(1-3): 1-16.
- Nilsson-Cantell, C. A.
1921. Cirripeden-Studien. Zur Kenntnis der Biologie, Anatomie und Systematik dieser Gruppe. Zool. Bidr. Uppsala 7: 75-395.
1930. Diagnoses of some new cirripedes from the Netherlands Indies collected by the Expedition of His Royal Highness the Prince Leopold of Belgium in 1929. Bull. Mus. Royal Hist. Nat. Belgique 6(4): 1-2.
- Pilsbry, H. A.
1928. Littoral barnacles of the Hawaiian Islands and Japan. Proc. Acad. Nat. Sci., Philadelphia 79: 305-317, pls. 24-26.
- Ross, A.
1968. Bredin-Archbold-Smithsonian biological survey of Dominica. 8. The intertidal balanomorph Cirripedia. Proc. U. S. Natl. Mus. 125(3663): 1-23.
1969. Studies on the Tetracitidae (Cirripedia: Thoracica): Revision of *Tetracita*. San Diego Soc. Nat. Hist., Trans. 15(15): 237-251.
1970. Studies on the Tetracitidae (Cirripedia: Thoracica): A proposed new genus for the austral species *Tetracita purpurascens breviscutum*. San Diego Soc. Nat. Hist., Trans. 16(1): 1-12.
- Utinomi, H.
1962. Studies on the cirripedian fauna of Japan. VIII. Thoracic cirripeds from western Kyusyu. Publ. Seto Mar. Biol. Lab. 10(2): 211-239.
1970. Studies on the cirripedian fauna of Japan. IX. Distributional survey of thoracic cirripeds in the southeastern part of the Japan Sea. Publ. Seto Mar. Biol. Lab 17(5): 339-372.
- Wood, W.
1815. General conchology; or a description of shells arranged according to the Linnean System. London, 246 p.

Department of Invertebrate Paleontology, Natural History Museum, P. O. Box 1390, San Diego, California 92112.

**STRATIGRAPHY OF THE POWAY AREA,
SOUTHWESTERN CALIFORNIA**

GARY L. PETERSON

TRANSACTIONS

**OF THE SAN DIEGO
SOCIETY OF
NATURAL HISTORY**

VOL. 16, NO. 9 9 JULY 1971

THIS PAGE IS LOCKED TO FREE MEMBERS
Purchase full membership to immediately unlock this page

FORGOTTEN BOOKS

FULL MEMBERSHIP

797,885 Books!
All you can read
for only
\$8.99/month

Continue

*Fair usage policy applies



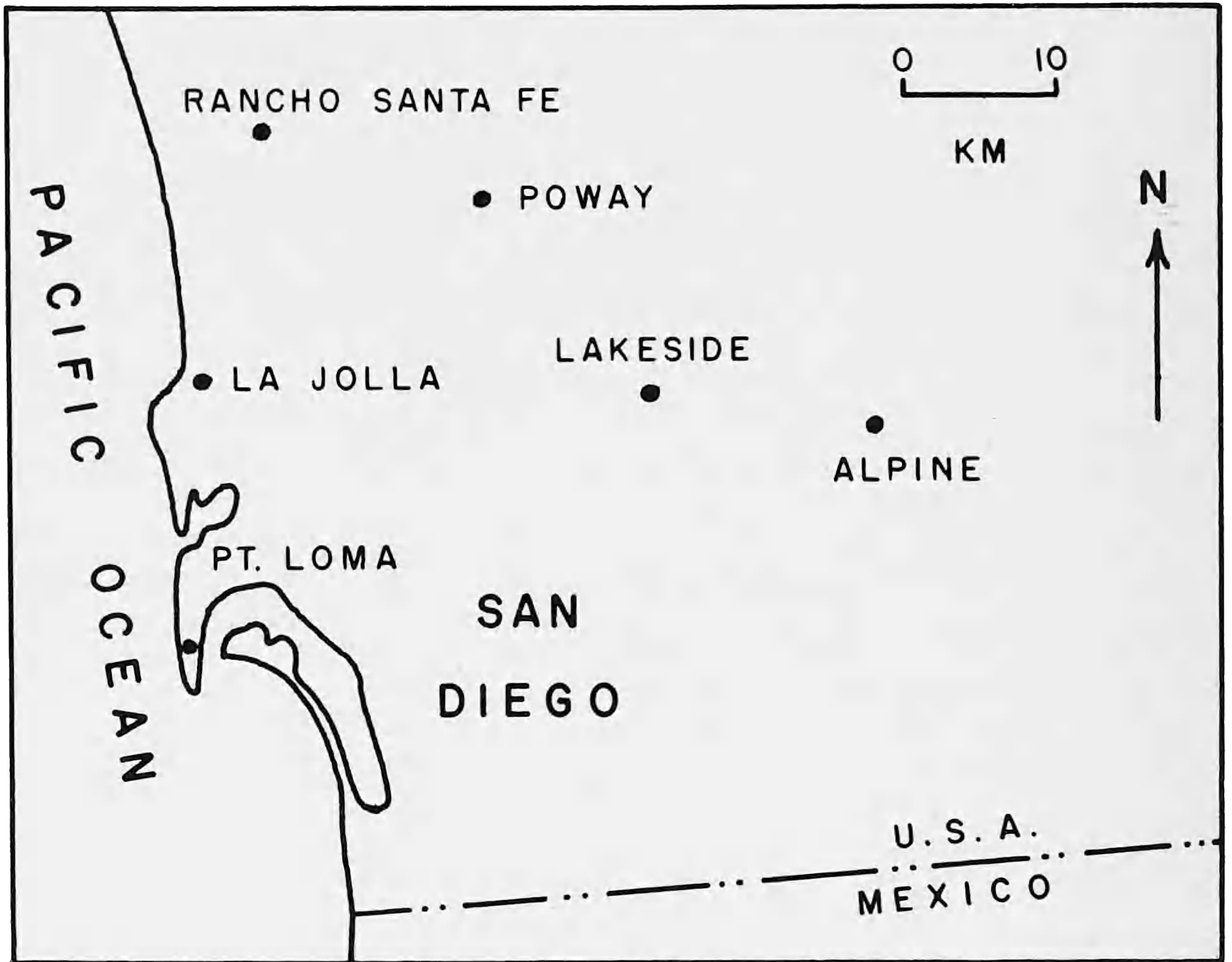

Figure 1. Index map of southwestern California showing localities mentioned in the text.

About five years ago several students practicing geologic mapping in the vicinity of Poway reported a conglomerate that differed significantly from typical exposures of the "Poway Conglomerate." This anomalous conglomerate came to mind again subsequent to detailed mapping in the Rancho Santa Fe area (Fig. 1), where a thick boulder conglomerate (now recognized as the Upper Cretaceous Lusardi Formation) that differs markedly from the Eocene conglomerates in texture and clast content lies unconformably beneath the Eocene strata (Nordstrom, 1970; Peterson and Nordstrom, 1970).

Re-examination of the sedimentary rocks cropping out in the vicinity of Poway indicated the presence of not one but three distinct and easily mappable formations. The first, or lowest, rock unit is a very coarse, severely weathered conglomerate correlated with the Upper Cretaceous Lusardi Formation of the Rancho Santa Fe area (Nordstrom, 1970). The middle unit is predominantly sandstone and shale and is here regarded as an extension of the newly recognized late Eocene Friars Formation (La Jolla Group) of Kennedy and Moore (1971). The upper unit is a thick and widespread cobble conglomerate and is correlated with the late Eocene Stadium Conglomerate (Poway Group) of Kennedy and Moore (1971).

The purpose of this paper is to describe and outline the principal distinctions between the three formations, to show their distributions on a geologic map, to correlate the formations with those mapped and described in the San Diego to the west-southwest and with formations recognized to the east-southeast in the Alpine-Lakeside area, and to indicate a local and regional sequence of events implied by these observations and interpretations.

The geology of the Poway area is depicted in figure 2. My principal interest was in the sedimentary rocks; thus the basement complex was not subdivided. The basement rocks consist predominantly of the mid-Cretaceous Southern California batholith (Larsen, 1948; Bushee *et al.*, 1963) and a few small patches of the pre-batholithic Santiago Peak Volcanics of Late Jurassic age (Fife *et al.*, 1967). An erosion surface having in excess of 300 meters of local relief was developed on the basement complex and the sedimentary formations rest on this irregular surface. The relief on the basement rocks exceeds the total thickness of the younger flat-lying sedimentary deposits by over 100 meters; thus the area is characterized by hills of relatively ancient basement rocks locally protruding through and standing well above the younger sedimentary deposits.

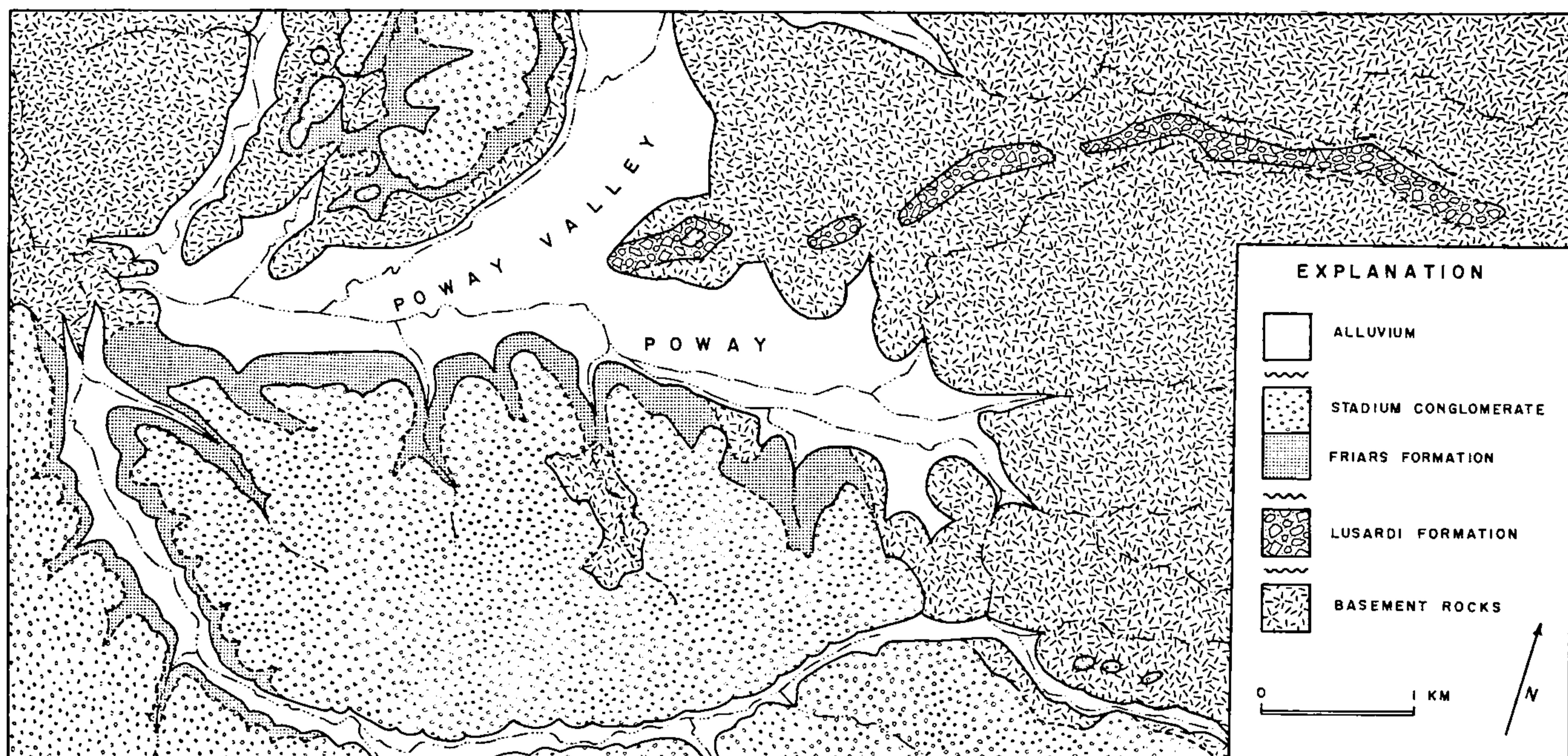

Figure 2. Geologic map of the Poway area.

LUSARDI FORMATION

The Lusardi Formation crops out in a narrow, six kilometer long belt extending east-northeast from Poway (Fig. 2). Apparently these deposits must have filled a former channel, although the present topography is reversed, and the deposits cap a long narrow ridge with the modern drainage incised deeply into the basement complex on either side. The ridge is utilized as a roadway and excellent Lusardi exposures can be observed in some of the cuts (Fig. 3).

The long exposure varies in altitude from about 550 meters near the eastern limit to less than 200 meters at Poway. Thickness of the Lusardi ranges from about 20 to 30 meters.

The westernmost Lusardi exposure appears to fill a northeast-trending, broadly V-shaped channel which terminates at Poway Valley. The channel probably extends farther to the west beneath the alluvium and the Eocene formations.

The Lusardi conglomerate consists of extremely poorly sorted clasts ranging in size from granules to boulders exceeding three meters in diameter. The clasts range in shape from angular to spheroidal; most are at least partially rounded. The conglomerate matrix is a poorly sorted, finer grained clastic assemblage dominantly derived from grus. The conglomerate has been severely weathered and many of the plutonic clasts have decomposed to grus; in such cases they are difficult to distinguish from the matrix. Also, many of the clasts are physically disintegrated *in situ* and yield sharp angular fragments giving the unit

the appearance of a coarse sedimentary breccia. The various clast types differ markedly in resistance to weathering. Therefore, where an outcrop on the surface is inspected, it is dominated by the more resistant clasts, whereas in a deep road cut the entire assemblage is exposed.



Figure 3. Outcrop of Lusardi Formation in road cut along Poway to Lakeside highway about two miles east of Poway. Note the typical texture of this formation. Striped bar used for scale in photograph is a Jacobs staff (five feet in length).

Some of the largest clasts are coarse-grained diorite and quartz diorite boulders slightly more than three meters in diameter. Some of the diorite clasts are severely weathered and contain finer grained resistant xenoliths, giving the appearance that the xenoliths are "cobbles" in a matrix of grus. Another abundant plutonic clast type is a resistant, medium-grained granodiorite containing quartz phenocrysts. The plutonic rock types listed above, together with minor amounts of aplite and vein quartz, constitute an estimated 60 per cent of the clasts in the conglomerate. All are common rock types found in the Southern California batholith in the Poway area and the region to the east.

Other clast types include a number of fine to very fine grained, light brown, greenish gray, and medium to dark gray metamorphosed tuffs. One of the most distinctive and common types is a medium gray weathering welded tuff containing finely crenulated flow banding; where broken to reveal the inner appearance, the rock appears very fine grained, dark, and without internal structure. Other clast types include very fine grained black hornfelsic rocks, and minor amounts of fine-grained volcanic breccia. All of these clast types resemble some of the more metamorphosed portions of the Santiago Peak Volcanics. The total assemblage of clasts found in the Lusardi is referred to as the Peninsular Ranges suite and is characteristic of Cretaceous formations in the San Diego area (Peterson *et al.*, 1968; Peterson, 1970a; Peterson and Nordstrom, 1970).

The Lusardi Formation was not recognized on previously published geologic maps of the Poway area, and it was included with the basement complex (Ellis and Lee, 1919; Hanna, 1926a). Likewise in the Rancho Santa Fe area, the type Lusardi appeared on pre-

THIS PAGE IS LOCKED TO FREE MEMBERS
Purchase full membership to immediately unlock this page

DELVE INTO FANTASY, MAGIC, MYTHOLOGY & FOLKLORE

Forgotten Books'
Full Membership gives
access to 797,885 ancient
and modern, fiction and
non-fiction books.

Continue

*Fair usage policy applies

along the northern margin of Mission Valley.

STADIUM CONGLOMERATE

The Stadium Conglomerate (Poway Group) is the thickest, most extensive, and best exposed stratigraphic unit in the Poway area. Along the southern side of Poway Valley, it is up to 150 meters thick. In the area to the northwest of Poway, it is up to about 50 meters thick. An excellent section of the Stadium Conglomerate is well exposed along Pomerado Road in the southwest corner of the map area (Fig. 2).

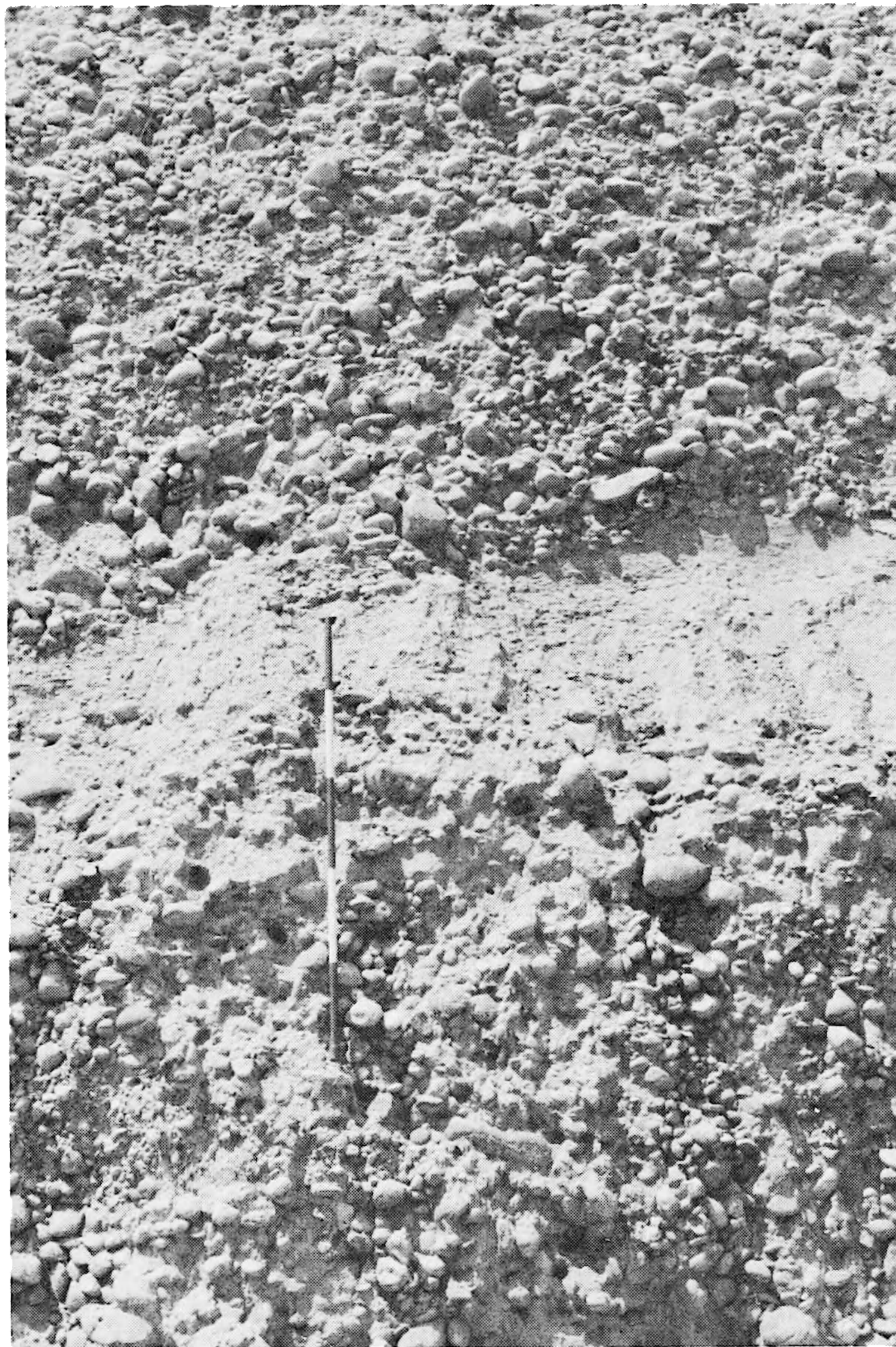

Figure 4. Outcrop of Stadium Conglomerate along Pomerado Road about one-half mile off the southwestern corner of the map (Fig. 2). Note the typical texture of this conglomerate and the presence of sandstone lenses. Scale is Jacobs staff.

Although the Stadium Conglomerate is dominated by conglomerate, as implied by the name, beds and lenses of sandstone and shale are locally evident, especially in the lower portion. The finer grained sediments in the lower part closely resemble those in the Friars Formation, whereas higher in the section the beds and lenses of sandstone and shale and the matrix of the conglomerate are cleaner, better sorted, and white to light brown. Many of the prominent sandstone lenses within the conglomerate probably represent sand bars developed in a river system.

The Stadium Conglomerate is typically fairly well sorted, at least relative to the Lusardi conglomerate (compare Fig. 3 and 4). Clast sizes range from granules to boulders 60 centimeters in diameter, but clasts over 30 centimeters in diameter are rare. Typically, the clasts are subrounded to rounded cobbles and small boulders. The texture of the Stadium Conglomerate and of other Eocene conglomerates in the San Diego area differs so markedly from that of the Lusardi that the two may be readily recognized on that basis alone (Peterson, 1970a).

The types of clasts found in the Stadium Conglomerate and in other Eocene and post-Eocene formations in the San Diego area are highly distinctive and easily recognized. The clasts consist predominantly of slightly metamorphosed rhyolitic to dacitic volcanic and volcanoclastic rocks, with a smaller but significant amount of quartzite. The various clast types (together referred to as the Poway suite of clasts) and their proportions are well described by Bellemin and Merriam (1958), De Lisle *et al.* (1965), and Woodford *et al.* (1968).

No fossils were found in the Stadium Conglomerate of the Poway area. However, in other parts of the San Diego area, the Poway Group including the Stadium Conglomerate has yielded a variety of marine and non-marine late Eocene fossils (Hanna, 1926b; Dusenbury, 1932; Cushman and Dusenbury, 1934; Stock, 1937, 1938; Kennedy and Moore, 1971). Evidently the Stadium Conglomerate was deposited very near sea level and represents a variety of fluvial, estuarine, and nearshore-marine depositional environments.

RELATIONSHIP BETWEEN CRETACEOUS AND EOCENE FORMATIONS

The westernmost outcrop of the Cretaceous Lusardi Formation is capped by a thin patch of the Stadium Conglomerate. This is the only locality within the map area where the Eocene rocks are in contact with the Lusardi Formation. The Stadium Conglomerate at this locality consists of a thin cobble conglomerate (approximately 7 meters thick), capping the crest of the hill, underlain by a thin (about 7 meters) unit of greenish sandstone and shale. Underlying this latter unit is the bouldery Lusardi Formation. Exposures of the three units are poor except for several road cuts. The conglomerate cap is identical in all respects to the Stadium Conglomerate as mapped throughout the area (figure 2). The sandstone and shale unit is lithically identical to the Friars Formation and to the lenses of sandstone and shale in the lower portion of the Stadium Conglomerate.

The Lusardi Formation of the Poway area is interpreted as a deposit formed by a very fast flowing, turbulent river. The character of the deposits suggests that the Lusardi filled a long narrow, fairly steep-walled canyon, although this topography is no longer evident. The Lusardi channel (or canyon) fill extended from the northeast into the Poway area, and probably continued far to the west of Poway.

After deposition of the Lusardi conglomerate, the area underwent erosion. A much wider, north to south sloping valley was cut across the Poway area. During, or following, this erosional episode the terrane (consisting of the Lusardi Formation and the basement rocks) underwent severe weathering. When deposition began again, the Eocene formations were deposited on the deeply weathered surface, filling in the low areas first and then lapping over onto the adjacent highlands.

The initial deposits, the Friars Formation, are both mineralogically and texturally immature. In gross character, the coarser grained sandstones of this formation strongly resemble *grus*. The finer grained portions were not studied in detail, but casual observation suggests that they are dominated by weathered products derived from the deeply weathered basement complex and probably from the Lusardi Formation as well. Much of the finer sediments of the Friars Formation and the lower portion of the Stadium Conglomerate were evidently derived locally. The conglomerates with the exotic Poway suite of

clasts, however, had to be transported into the area from a considerable distance.

REGIONAL IMPLICATIONS

The sequence of post-batholithic rock units in the Rancho Santa Fe area (Fig. 5) includes the Lusardi Formation, which is unconformably overlain by the Eocene La Jolla Group. The unconformity between the two units can be demonstrated to have about 130 meters of relief, although both rock units are essentially flat lying (Peterson and Nordstrom, 1970). The identical sequence of rock units, unconformable relationship between them, and the implied sequence of events is evident in the Poway area except that the Eocene rock units are far more conglomeratic and appear to be predominantly non-marine.

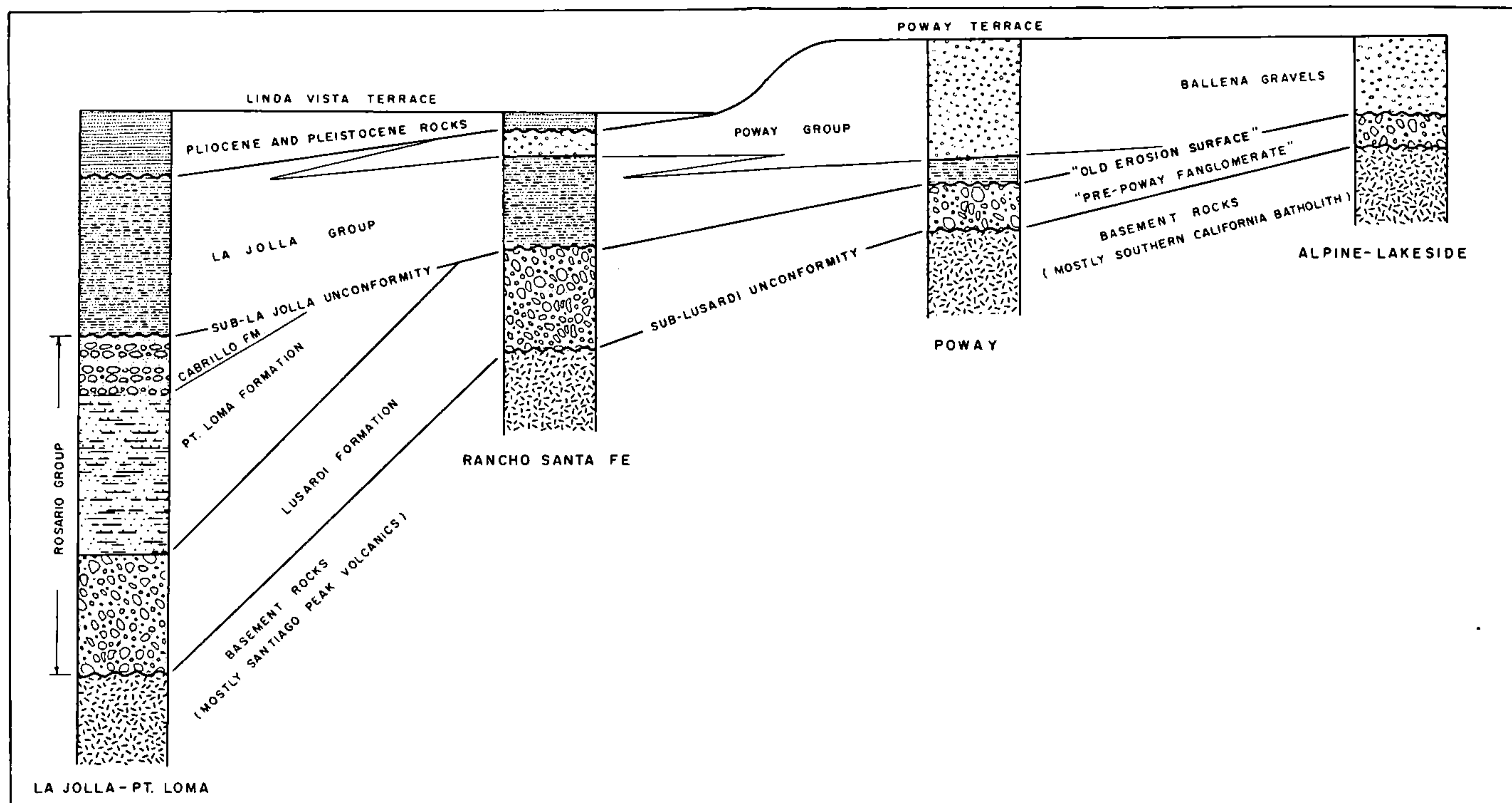

Figure 5. Correlation diagram emphasizing relationships between Cretaceous and Eocene rock units in the northern and eastern part of the San Diego area. Thickness of rock units is not to scale, but is roughly proportional.

East and southeast of the Poway area, a number of small and widely scattered outcrops of "pre-Poway fanglomerate deposits" were reported and briefly described in a field trip guidebook (Gastil, 1961; Gastil and Bushee, 1961). Most of the outcrops are within 15 kilometers of the communities of Alpine and Lakeside (Fig. 1). I revisited several of the localities for comparative purposes. In gross character, these deposits strikingly resemble the Lusardi Formation of the Poway area and the type Lusardi near Rancho Santa Fe. The deposits are very poorly sorted and contain a wide variety of clasts derived from the local basement complex (Peninsular Ranges suite). Some of the clasts are exceptionally large (diameter greater than three meters) and many clasts are deeply weathered. Locally the conglomerate has a reddish matrix; elsewhere the matrix is light brown, green, or gray. Clast types characteristic of the Eocene formations (Poway suite) are absent.

Where field relations are evident (see especially the southwest and central portions of geologic map number 2 of Gastil and Bushee, 1961), the "pre-Poway" conglomerate appears to be deeply channeled into the basement complex and is overlain by the "Poway Conglomerate" (or the equivalent "Ballena Gravels"). On the basis of stratigraphic position and lithic similarity, I regard all the outcrops of "pre-Poway fanglomerates" reported

THIS PAGE IS LOCKED TO FREE MEMBERS
Purchase full membership to immediately unlock this page

FORGOTTEN BOOKS

FULL MEMBERSHIP

797,885 Books!
All you can read
for only
\$8.99/month

Continue

*Fair usage policy applies



sion surface" without totally destroying the relief. Thus the unconformity beneath the Eocene rocks has several hundred to several thousand feet of relief, and hills composed of pre-Eocene rocks locally protrude through the Eocene cover (Hanna, 1926a; Peterson and Nordstrom, 1970).

With the beginning of Eocene deposition, the Poway suite of clasts first arrived in the San Diego area. The clasts were evidently transported a considerable distance, at least 100 kilometers and probably more, for there is no known local source area. Potential distant source areas from the Mojave Desert to Sonora, Mexico have been proposed (De Lisle *et al.*, 1965; Merriam, 1968; Woodford *et al.*, 1968; Minch, personal communication, 1970). The intent here is not to resolve the Poway clast provenance problem. It is sufficient to say that these exotic clasts did not arrive in the San Diego area until mid-Eocene time and thus they have a chronologic significance. Regardless of where they came from, they are abundant in all Eocene conglomerates of the San Diego area and are absent in pre-Eocene units.

In marked contrast to the Cretaceous conglomerates, the Eocene conglomerates contain a very low proportion of clast types that might have been derived from the local basement rocks. Outcrops containing more than 10 per cent clasts resembling the pre-batholithic and batholithic rocks are rare. It should be pointed out that, although some clasts resemble the local basement rocks, they too may have been transported into the San Diego area along with the exotic Poway clasts (Minch, 1970). The paucity of locally derived coarse detritus suggests that the San Diego region was relatively low lying during Eocene deposition. Some of the fine detritus found in the Eocene formations, such as that of the Friars Formation and the lower portion of the Stadium Conglomerate near Poway, was probably locally derived and contributed by minor streams. The Poway suite of clasts, however, had to be transported across the low lying "old erosion surface" to the site of accumulation in the San Diego area.

Following Eocene deposition, the San Diego area has undergone several uplifts including the cutting of three widespread coastal terraces (Ellis and Lee, 1919; Hanna, 1926a; Peterson, 1970b). This post-Eocene uplift and erosion has resulted in extensive dissection of the Eocene deposits, locally revealing the underlying fragments of the Lusardi Formation.

ACKNOWLEDGMENTS

I would like to thank W. J. Elliott, A. H. James, and R. T. La Borde for pointing out the seemingly anomalous conglomerate in the Poway area. In addition, I would like to thank J. A. Minch, C. E. Nordstrom, M. P. Kennedy and R. G. Gastil for many stimulating discussions concerning the conglomerates of the San Diego area. Thanks are due to Armando Estrada for translation of the abstract into Spanish.

LITERATURE CITED

- Bellemin, G. J., and R. H. Merriam
1958. Petrology and origin of the Poway Conglomerate, San Diego County, California. *Geol. Soc. Amer. Bull.* 69:199-220.
- Bushee, J., J. Holden, B. Geyer, and G. Gastil
1963. Lead-alpha dates for some basement rocks of southwestern California. *Geol. Soc. Amer. Bull.* 74:803-806.
- Cushman, J. A., and A. N. Dusenbury, Jr.
1934. Eocene foraminifera of the Poway Conglomerate of California. *Contr. Cushman Lab. Foram. Res.* 10:51-65.
- De Lisle, M., J. R. Morgan, J. Heldenbrand, and G. Gastil
1965. Lead-alpha ages and possible sources of metavolcanic rock clasts in the Poway Conglomerate, southwest California. *Geol. Soc. Amer. Bull.* 76:1069-1074.

Dusenbury, A. N., Jr.

1932. A faunule from the Poway Conglomerate, upper middle Eocene of San Diego County, California. *Micropaleontology* 3:84-95.

Ellis, A. J., and C. H. Lee

1919. Geology and ground waters of the western part of San Diego County, California. U.S. Geol. Survey Water-Supply Paper 446:1-321.

Fife, D. L., J. A. Minch, and P. J. Crampton

1967. Late Jurassic age of the Santiago Peak Volcanics, California. *Geol. Soc. Amer. Bull.* 78:299-304.

Flynn, C. J.

1970. Post-batholithic geology of the La Gloria-Presa Rodriguez area, Baja California, Mexico. *Geol. Soc. Amer. Bull.* 81:1789-1806.

Gastil, G.

1961. The elevated erosion surfaces. *In*, Field trip guidebook, San Diego County. *Geol. Soc. Amer. (Cordilleran Section) 57th Ann. Mtg.*, 1-4.

Gastil, G., and J. Bushee

1961. Geology and geomorphology of eastern San Diego County. *In*, Field trip guidebook, San Diego County. *Geol. Soc. Amer. (Cordilleran Section) 57th Ann. Mtg.*, 8-22.

Hanna, M. A.

- 1926a. Geology of the La Jolla quadrangle, California. *Univ. California Publ. Geol. Sci.* 16:187-246.
1926b. An Eocene invertebrate fauna from the La Jolla quadrangle, California. *Univ. California Publ. Geol. Sci.* 16:247-398.

Kennedy, M. P., and G. W. Moore

1971. Stratigraphic relations of Upper Cretaceous and Eocene formations, San Diego Coastal area, California. *Amer. Assoc. Petrol. Geol. Bull.* 55:709-722.

Larsen, E. S., Jr.

1948. Batholith and associated rocks of Corona, Elsinore, and San Luis Rey quadrangles, southern California. *Geol. Soc. Amer. Mem.* 29:1-182.

Merriam, R. H.

1968. Geologic reconnaissance of northwest Sonora. *In*, Proceedings of conference on geologic problems of San Andreas fault system. *Stanford Univ. Publ. Geol. Sci.* 11:287.

Minch, J. A.

1970. Early Tertiary paleogeography of a portion of the northern Peninsular Range. *In*, Pacific slope geology of northern Baja California and adjacent Alta California. *Amer. Assoc. Petrol. Geol. (Pacific Section) Fall Field Trip Guidebook*, 4-9.

Nordstrom, C. E.

1970. Lusardi Formation: a post-batholithic Cretaceous conglomerate north of San Diego, California. *Geol. Soc. Amer. Bull.* 81:601-606.

Peterson, G. L.

- 1970a. Distinctions between Cretaceous and Eocene conglomerates in the San Diego area, southwestern California. *In*, Pacific slope geology of northern Baja California and adjacent Alta California. *Amer. Assoc. Petrol. Geol. (Pacific Section) Fall Field Trip Guidebook*, 90-98.
1970b. Quaternary deformation of the San Diego area, southwestern California. *In*, Pacific slope geology of northern Baja California and adjacent Alta California. *Amer. Assoc. Petrol. Geol. (Pacific Section) Fall Field Trip Guidebook*, 120-126.

Peterson, G. L., R. G. Gastil, J. A. Minch, and C. E. Nordstrom

1968. Clast suites in the late Mesozoic-Cenozoic succession of the western Peninsular Ranges province, southwestern California and northwestern Baja California (abst.). *Geol. Soc. Amer. Spec. Paper* 115:177.

Peterson, G. L., and C. E. Nordstrom

1970. Sub-La Jolla unconformity in vicinity of San Diego, California. *Amer. Assoc. Petrol. Geol. Bull.* 54:265-274.

Stock, C.

1937. An Eocene titanotherium from San Diego County, California, with remarks on the age of the Poway Conglomerate. *Natl. Acad. Sci. Proc.* 23:48-53.
1938. A tarsiid primate and a mixodectid from the Poway Eocene, California. *Natl. Acad. Sci. Proc.* 24:288-293.

Woodford, A. O., E. E. Welday, and R. H. Merriam

1968. Siliceous tuff clasts in the upper Paleogene of southern California. Geol. Soc. Amer. Bull. 79:1461-1486.

Department of Geology, San Diego State College, San Diego, California 92115.

THIS PAGE IS LOCKED TO FREE MEMBERS
Purchase full membership to immediately unlock this page

DELVE INTO FANTASY, MAGIC, MYTHOLOGY & FOLKLORE

Forgotten Books'
Full Membership gives
access to 797,885 ancient
and modern, fiction and
non-fiction books.

Continue

*Fair usage policy applies

HERPETOFAUNA OF THE PACIFIC COAST OF NORTH CENTRAL BAJA CALIFORNIA, MEXICO, WITH A DESCRIPTION OF A NEW SUBSPECIES OF *PHYLLODACTYLUS XANTI*

DENNIS L. BOSTIC

ABSTRACT.—Three species of lizards are recorded from the Pacific slope of Baja California, Mexico, for the first time: a leaf-toed gecko, *Phyllodactylus xanti sloani* n. subsp., *Crotaphytus collaris* and *Sauromalus australis*. The distribution, pattern, and scutellation of *Gerrhonotus multicarinatus* spp. indicates a southward expansion of its range since glacial maxima via the cool, moist, coastal corridor, and its possible integradation with *G. paucicarinatus*. A southward coastal corridor diffusion may also be true for *Tantilla planiceps eiseni*, *Coleonyx variegatus abbotti* and *Lichanura roseofusca gracia*. Of the 29 species of amphibians (2), lizards (16), and snakes (11) collected, only one lizard, *Cnemidophorus labialis*, is considered endemic to the Central Desert of Baja California. Homogeneity of habitats, the moderate climate and the extirpation of the Peninsular desert herpetofauna during glacial maxima probably have been important factors in reducing or limiting species diversity and endemism.

INTRODUCTION

The coastal deserts of North America, of which more than 2000 miles are confined to Baja California and Sonora, Mexico, remain biologically unknown because of their relative inaccessibility, lack of potable water, and rugged terrain. Wiggins (1960a) identified these and other regions in Baja California as in need of more careful biological exploration. One area he mentioned was the Pacific coastal region between El Rosario (30°N) and the southern boundary of the state of Baja California (28°N; Fig. 1). Excluding the immediate areas of El Rosario and Rosarito, where the main road approaches within ten miles of the ocean, this region has not been explored herpetologically.

In the spring and summer of 1969, I made several trips (Table 1) into the area in order to: 1) better ascertain the distributional limits of the herpetofauna, 2) gather ecological data; and 3) collect specimens for studies of geographical variation and evolution.

METHODS AND MATERIALS

A Taylor sling psychrometer and a Dwyer wind gauge (0-60 mph) were used to measure relative humidity and wind speed. A Taylor soil thermometer (0-50°C) and a multi-channel tele-thermometer unit were used to record soil (approximately 0.5cm beneath surface) and air temperatures (approximately 0.5cm above surface). Time (Standard) is expressed in 24 hour fashion. Throughout this paper when counts or measurements are presented in the following manner: $11 \pm 1.3(10-12)18$, the first figure refers to the arithmetic mean, the second figure to the standard error of the mean, the figures in parentheses to the range, and the last figure to the number of observations. Occasionally, the standard error of the mean is omitted, but the order, with this exception, remains the same. Standard deviation is indicated by S.D.

All snout-vent measurements have been rounded off to the nearest whole number and other measurements to the nearest tenth.

Within each major systematic grouping the species are arranged alphabetically by genus. I have not been consistent in the treatment of subspecies and have omitted available trinomials where geographical variation is poorly known. All material collected has been deposited in the collections of the San Diego Society of Natural History.

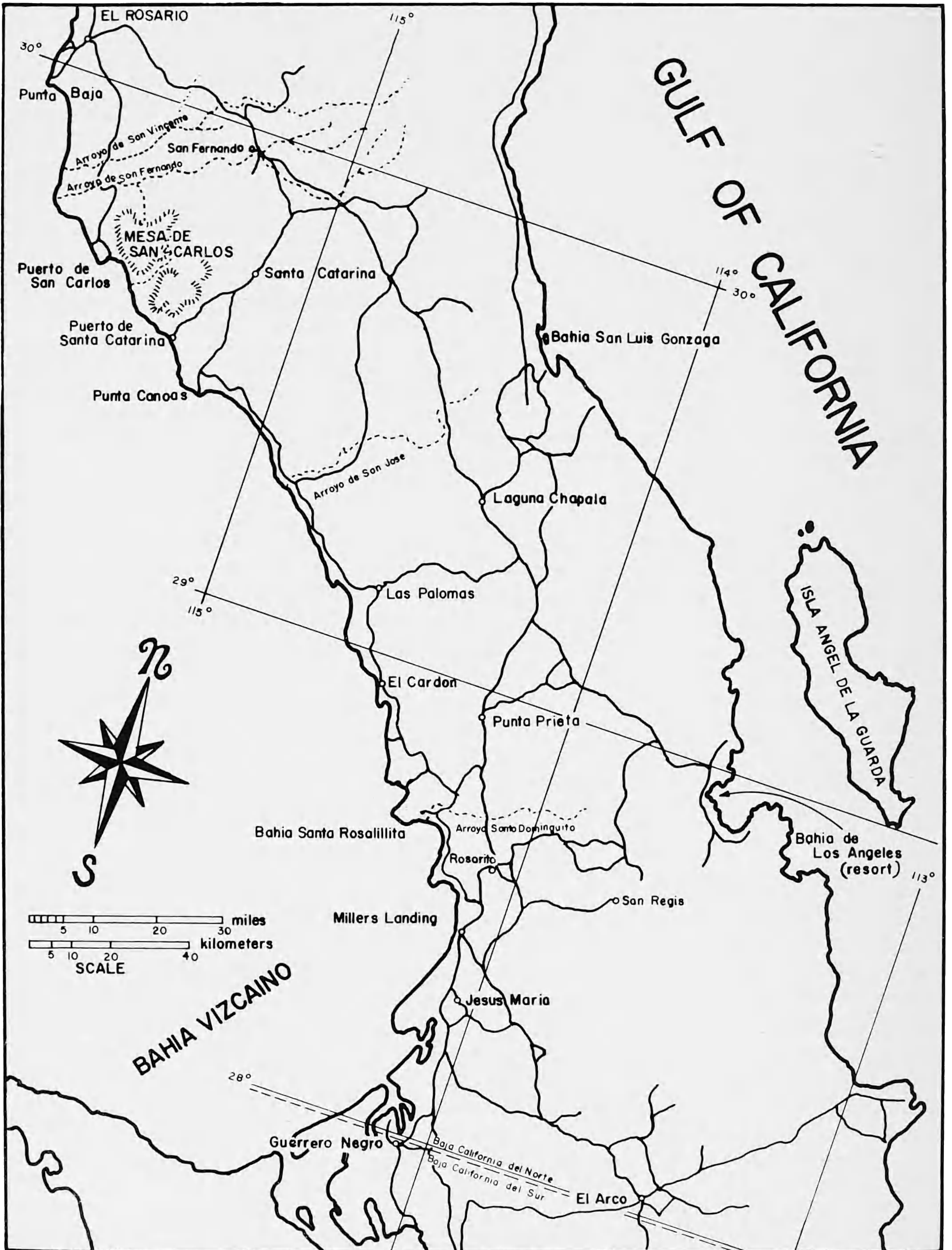

Figure 1. Map of the central region of Baja California, Mexico. Modified from Gerhard and Gulick, 1966.

THIS PAGE IS LOCKED TO FREE MEMBERS
Purchase full membership to immediately unlock this page

FORGOTTEN BOOKS

FULL MEMBERSHIP

797,885 Books!
All you can read
for only
\$8.99/month

Continue

*Fair usage policy applies



Mártir, in the east by the peninsular divide, and in the south by the northern and north-western borders of the great lava plateau, but with a Pacific strip extending further southward to the vicinity of Comondú. This semi-arid region was first named the Vizcaino Desert District by Nelson (1921) who made a biological survey of the peninsula in 1905-1906. Since then it has been called the San Borja Desert (Sauer and Meigs, 1927), the Vizcaino-Magdalena Desert (Jaeger, 1957), the Central Desert (Aschmann, 1959), the Peninsular Desert (Savage, 1960), and the Vizcaino Region (Shreve and Wiggins, 1964).

Sauer and Meigs' (1927) "San Borja Desert," based on a socio-economic division of the mission era, implies too restricted a geographical area, and Savage's (1960) "Peninsular Desert," is too inclusive. Jaeger's (1957) "Vizcaino-Magdalena Desert" is misleading. The Magdalena Plain, farther south on the Pacific drainage of the peninsula differs floristically from the Vizcaino Region (Shreve and Wiggins, 1964). I have chosen to call the area the "Central Desert" as suggested by Aschmann (1959) because it seems desirable to restrict the Vizcaino Desert, in accordance with local practice, to the dry coastal plain west of San Ignacio.

CLIMATE

Until 1963 few climatological data were available for Baja California, most of which were qualitative. Important additions to these data were presented by Hastings and Turner (1964, 1965a) and Hastings and Humphrey (1969).

Climatologically, the Central Desert may be classified on the origin of its climate (causally) and on the nature of its temperature (thermally), particularly in the winter. Causally, it is a cool coastal phase of a subtropical desert, the Sonoran; thermally, it may be classified as temperate.

The survey area is included within Meigs' (1966) "fog type" of temperate desert, and in the system of notation used in the UNESCO arid homoclimatic maps (Meigs, 1953) would be classified as Ac23—a desert climate with winter precipitation, the coldest month being between 10°C and 20°C (50°-68°F) mean temperature, and the warmest month between 20°-30°C (68°-86°F) mean temperature.

Table 2. Irregular observations (n) of wind velocity and direction.

	Wind Velocity (mph)			Direction		
	0700	1100	1500	0700	1100	1500
June	1.4-5.2 (5)	3.2-7.2 (5)	4.8-9.8 (5)	WNW(2) ENE(3)	WNW(5)	WNW(5)
July	0.6-3.2 (15)	3.0-8.2 (18)	3.7-10.4 (18)	W(5) NW(2) WSW(1)	W(14) NW(2)	W(12) SW(2)
August	0.0-2.2 (5)	1.9-9.8 (8)	1.3-8.6 (7)	W(1) SW(2)	W(3) SW(4)	W(2) SW(2) S(2)

The climate of the western coastal fringe of the Central Desert is greatly influenced by the cold California Current of the Pacific Ocean and the prevailing westerly winds (Table 2) which move layers of cool, moist air inland beneath dry descending air, producing considerable fog and cloudiness, but no precipitation, and very mild conditions.

In our survey, onshore movement of the moist marine air, often as fog or low clouds,

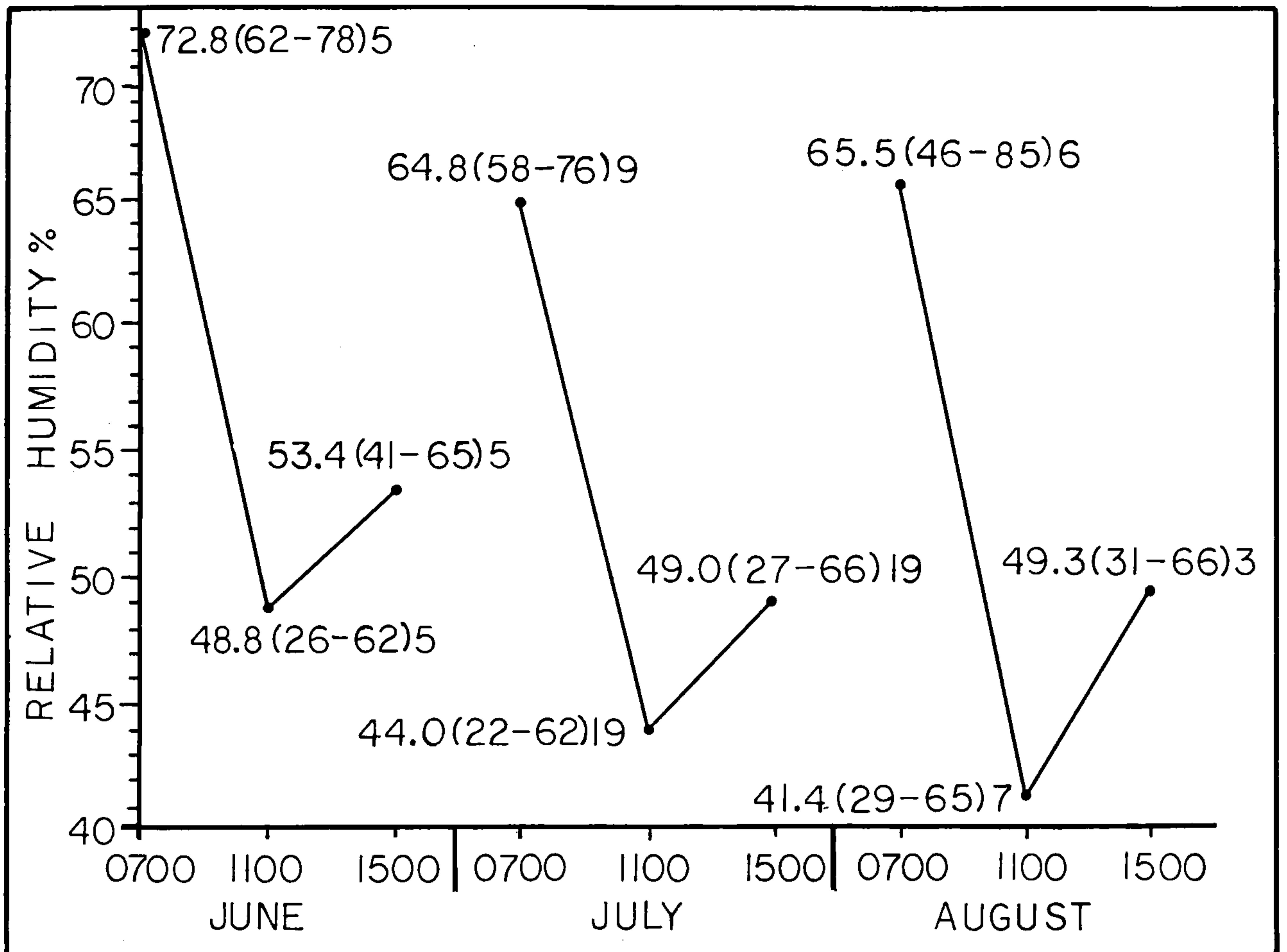

Figure 2. Relative humidity recorded in the Pacific coastal strand of the Central Desert of Baja California del Norte, Mexico, during June, July and August, 1969. The first figure refers to the arithmetic mean, the figures in parentheses to the ranges, and the last figure to the number of measurements.

generally began in mid-afternoon when wind velocities were greatest (Table 2). The relative humidity increased in mid-afternoon and dropped substantially in mid-morning when the fog and cloud cover dissipated (Fig. 2). The frequency and extent of the fog or cloud cover diminished rapidly with distance from the ocean. Although Arnold (1957) reported frequent fogs in the Chapala Basin, about 25 miles from the Pacific, during the spring and summer of 1949 and 1950, fog was seldom observed during this survey more than five miles from the ocean.

By late evening, along the coastal strand, visible drops of condensation formed on those objects that had cooled most rapidly after sunset, and by early morning substantial amounts of water, often 100 ml. or more, were present frequently in the depressions of rocks and in the axils of the basal leaves of *Agave*. Similarly, in the sandy soil beneath woody shrubs the extent of the plant drip was noticeable and, as recorded by Wiggins (1969) for shrubs of the Vizcaino Desert, often the subsoil was dampened to a depth of 4-5mm. Dr. James R. Hastings (pers. comm.) noted that on foggy mornings in the Vizcaino Region the ground was visibly more moist under *Opuntia cholla* and *Machaerocereus gummosus* than in open spaces, and that rivulets of condensate were observed running down the upper, concave surface of the leaves of *Yucca valida* and *Agave* sp., being funneled toward the caudex. Hastings and Turner (1965b) suggest that some plants of the Vizcaino Region may utilize the fog drip as a major source of water. Certainly the common epiphyte *Tillandsia recurvata*, which grows on woody shrubs and succulents, is dependent upon dew, as are many of the lichens of the coast such as *Ramalina reticulata*. Distribution of these moisture-dependent

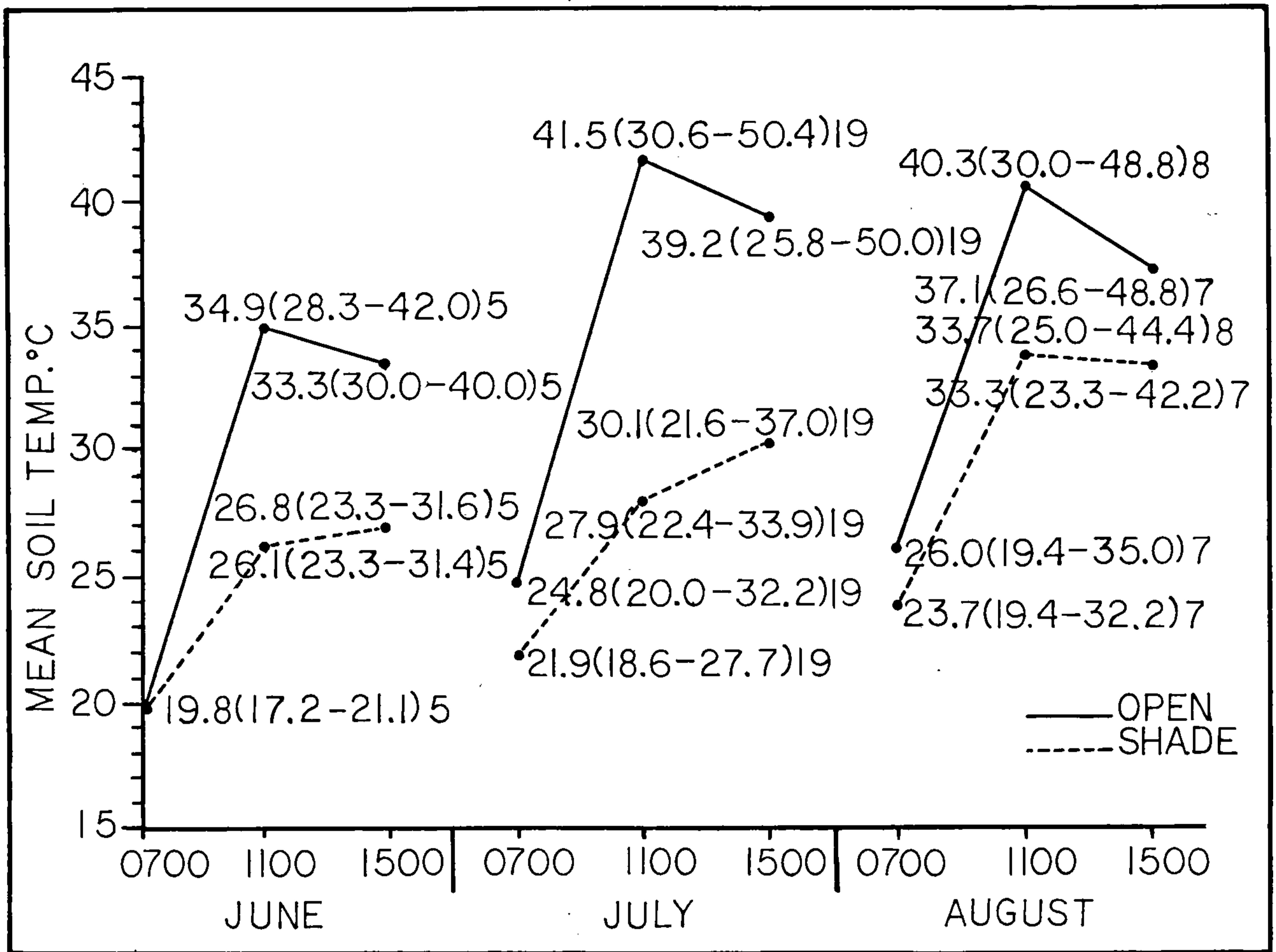

Figure 3. Soil temperatures recorded at various collecting stations in the Central Desert of Baja California, Mexico, during June, July and August, 1969. See Fig. 2 for explanation of figures.

plants may serve to delimit the coastal area of the Central Desert.

As noted by McGinnies *et al.* (1968), evaporation retards heating of the soil and vegetation, and may eliminate or reduce excessive heat loads, or it may keep the plant temperature below that required for optimum growth. This factor, concomitant with the temperature stabilizing effect of the ocean itself and the prevalence of strong, prevailing onshore winds, may be important in maintaining a distinction between the east and west coast floras.

The Pacific coast of Baja California as far south as Bahía Magdalena, with a mean January temperature above 18°C (64.4°F) and a subtropical climate, receives its maximum precipitation in winter (December-February), with the Central Desert receiving a winter average of 56mm (Hastings and Turner, 1965a). Winter storms generally cover a large area, are relatively gentle and may persist for days. But only in that area north of the Central Desert, the approximate southern limit of the Sierra San Pedro Mártir, do surface and ground water occur with any regularity. Near the coastal strand, the only surface waters encountered that were readily accessible to wildlife were the springs of San Felipe (Fig. 5) and Las Palomas, a small stream in San Javier Arroyo (Fig. 6), and numerous "tinajas" or tanks in the gulches and small canyons of the foothills.

Precipitation in fall (September-November), spring (March-May) and summer (June-August), in that order, is progressively less. In summer, when relative humidity tends to be low, rainfall is limited to thunder storms which are localized, relatively intense and of short duration. Rainfall from such storms was experienced on 24 June and 24 August.

THIS PAGE IS LOCKED TO FREE MEMBERS
Purchase full membership to immediately unlock this page

DELVE INTO FANTASY, MAGIC, MYTHOLOGY & FOLKLORE

Forgotten Books'
Full Membership gives
access to 797,885 ancient
and modern, fiction and
non-fiction books.

Continue

*Fair usage policy applies

concentrates at the base of slopes, the vegetation is fairly abundant. The most conspicuous perennial plants of the Central Desert listed by Wiggins (1960b), Shreve and Wiggins (1964), and Aschmann (1959), included the following: *Agave* spp., *Ambrosia chenopodiiifolia*, *Ambrosia magdalenae*, *Yucca valida*, *Idria columnaris*, *Machaerocereus gummosus*, *Larrea divaricata*, *Lycium californicum*, *Atriplex polycarpa*, *Viguiera deltoidea*, *Dudleya* spp., *Encelia* spp., *Euphorbia* spp., *Opuntia cholla*, *Viscainoa geniculata*, *Pachycereus pringlei*, *Lophocereus schottii*, *Echinocereus brandegeei*, *Fouquieria splendens*, *Prosopis* spp., *Cercidium* spp., *Solanum* spp., and *Pachycormus discolor*.

Also common in appropriate coastal strand habitats were *Frankenia palmeri*, *Atriplex canescens* and *Atriplex julacea*.¹

SPECIES ACCOUNT

AMPHIBIANS

Bufo punctatus

Each evening at San Javier Arroyo (Fig. 6) trilling choruses of toads were audible. On the evening of 14 July several pairs were observed in amplexus along a 100 meter stretch of a stagnant stream. The tadpoles, with well-developed hindlimbs, were collected from a small, shallow, algae-covered pool. A total of 83 specimens (65 adults, 18 tadpoles) were taken at Station 38.

Hyla regilla deserticola

Ten adults and two tadpoles of this race (see Jameson *et al.*, 1966, for distribution and characters) were collected at San Felipe Springs (Sta. 8; Fig. 5), a small perennial spring marked by luxuriant vegetation consisting of cottonwoods, willows, fan palms, cirio, pithaya and tules. The adults were found beneath rocks and in the grass and tules surrounding the main body of water, a shallow pond about five meters wide. The tadpoles were collected in another small pool.

Twenty-five adults were collected from rock crevices and from beneath rocks flanking the stagnant San Javier stream (Sta. 38, Fig. 6). Adults called late into the evening.

LIZARDS

Callisaurus draconoides crinitus

These lizards were confined to a coastal (Sta. 40; 8 specimens) and inland (Sta. 41; 28 specimens) sand dune habitat. Many individuals were approached within several feet and collected by stunning them with six-inch rubberbands.

Nine of the 18 females collected between 15-17 July had yolk-laden ovarian ova greater than 3mm in diameter, and four of the 18 contained oviducal ova. The mean length and width of ovarian ova in the left and right ovaries were 5.6(3.3-9.5)11 by 4.9(2.8-8.7)11 and 6.2(4.7-9.0)9 by 5.7(4.5-7.8)9, respectively. Oviducal ova in the left oviduct measured 15.2(14.0-16.7)3 by 8.0(7.4-8.7)3 and in the right oviduct 15.1(13.7-17.8)7 by 9.2(7.3-11.0)7.

Male *crinitus* average longer than females; mean lengths for 18 males and 18 females being 68.4mm (range 47-82mm) and 59.9mm (range 46-68mm). The mean testis size of the series collected in mid-July was 4.6mm(range 3.2-5.8mm) by 3.1mm(range 2.4-4.0mm). The right testis was anterior to the left in all males examined.

Measurements and counts of *crinitus* are summarized in Table 3. The distance between the anterior edge of the most anterior ventral tail bar and the posterior margin of the anus, a

¹A list of other dominant plants representative of the major herpetological collecting stations in this area, is filed with the National Auxiliary Publication Service of the American Society for Information Service, and may be obtained by ordering NAPS Document 01547 from ASIS National Auxiliary Publication Service, CCM Information Corp., 909 Third Ave., New York, N.Y. 10022, remitting \$5 per photocopy or \$2 per microfiche copy.

measurement suggested by Dr. Benjamin Banta, readily separates *crinitus* from *rhodostictus* and appears to be much more reliable than the diagnostic characters used previously to separate these races (see Tevis, 1944). The number of oblique lateral bars was variable among the 35 *crinitus* examined; nine had none; three had two, two had four, and 21 had the three characteristic of the race.

Except for snout-vent length, the only important sex difference was the hindlimb length: males, 63.7(47-75)18, females, 55.2(45-64)18. Also, females tended to lack the oblique body bars more frequently than males; eight females out of the 18 had none, whereas only one of 17 males lacked the bars entirely.

Callisaurus draconoides rhodostictus

Individuals of *rhodostictus* were generally confined to sandy washes and broad, sandy arroyos. At the most inland collecting stations, where the soil is largely decomposed granite,

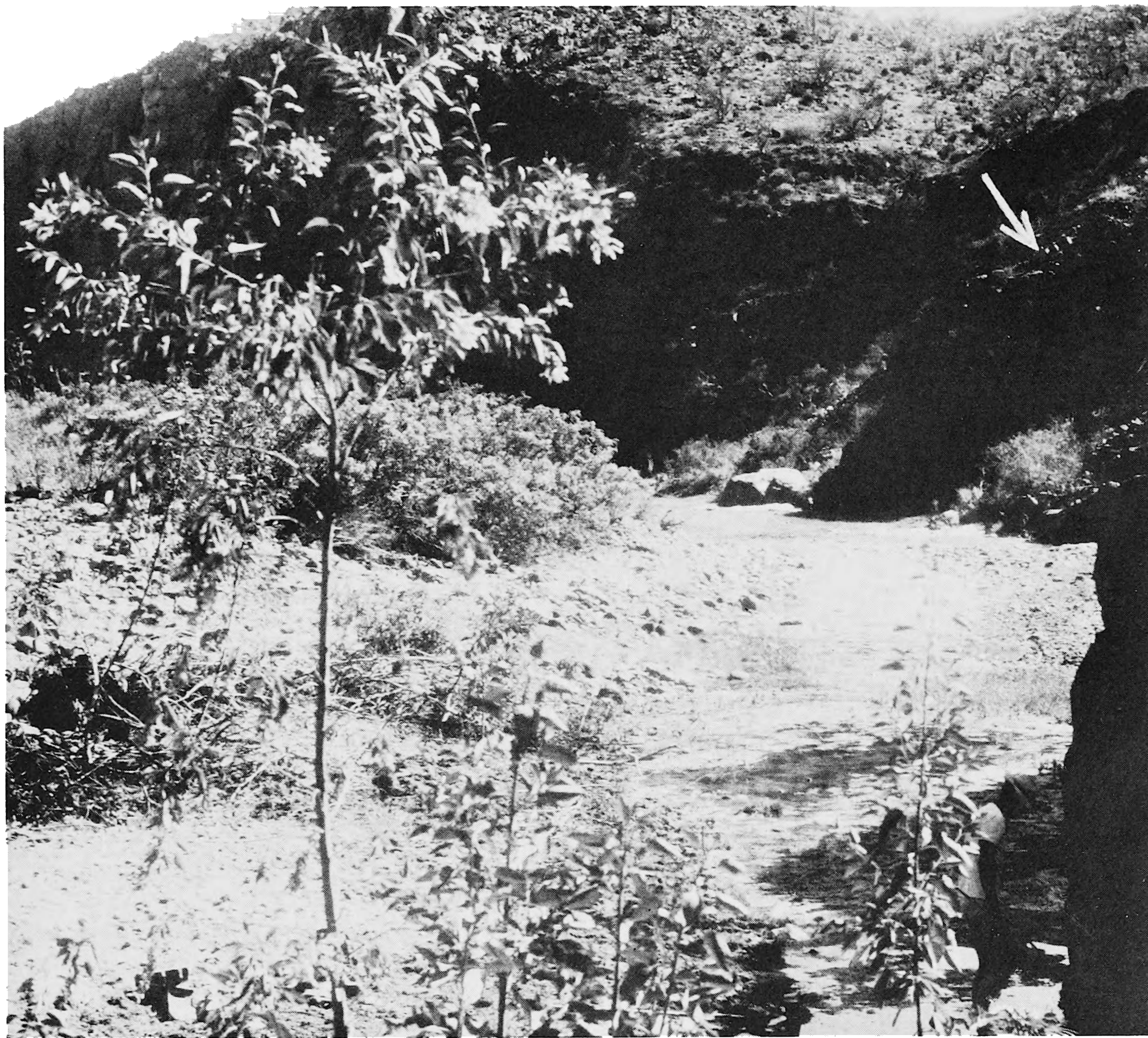

Figure 5. Station 8, San Felipe Springs (in arroyo de San Fernando), about nine miles NE of the arroyo-coastal road junction. Several adult *Hyla regilla deserticola* were collected beneath rocks and in the grass and tules surrounding the main body of water (see arrow); tadpoles were collected in another small pool of water not visible in photograph.

Table 3. Measurements and counts of *Callisaurus draconoides crinitus* and *C. d. rhodostictus*.

	<i>crinitus</i>	<i>rhodostictus</i>
Snout-vent length	64.1(46-82)36 S.D. = 9.9	68.9(38-85)29 S.D. = 9.8
Ratio, tail: total length	5.7(5-6)19 S.D. = 0.4	5.8(4-6)14 S.D. = 0.6
Distance between anus to most anterior ventral tail bar	15.9(7-26)34 S.D. = 5.2	3.4(1-7)29 S.D. = 1.5
Hindlimb length	59.4(45-75)36 S.D. = 8.7	64.5(32-84)17 S.D. = 8.9
Ventral body bars	2.2(0-4)35 S.D. = 1.3	1.8(0-2)29 S.D. = 0.6
Ventral tail bars	6.8(0-10)20 S.D. = 1.8	7.6(4-10)30 S.D. = 1.4
Femoral pores ¹	18.2(14-22)35 S.D. = 1.6	13.8(11-18)27 S.D. = 1.6

¹Femoral pores counted on one side only.

rhodostictus were often observed basking during mid-day atop small rocks.

Only four of the 17 female *rhodostictus* collected had enlarged yolk-laden ovarian ova, [mean size: 5.3(3.2-6.9)12 by 4.8(3.2-6.0)12], and none had oviducal eggs. The specimens with enlarged ovarian ova were collected in late August, whereas the *crinitus*, four of which had oviducal ova, were collected in mid-July. This suggests that egg laying among *crinitus* and *rhodostictus* ceases between the end of July and August in the Central Desert.

Males tend to be larger than females; males had a mean snout-vent length of 75.3(61-85)12 and females a mean snout-vent length of 64.3(38-75)17. The testes of eight *rhodostictus* averaged 4.8(3.5-6.8)15 by 3.3(2.0-4.5)15. The right testes was anterior to the left in all males examined, and was usually slightly larger.

Other counts and measurements for *rhodostictus* are presented in Table 3. The mean hindlimb length, 76.1(61-84)12 for males and 64.5(32-72)17 for females, and the mean snout-vent length, previously mentioned, were the only apparent quantitative differences between the sexes. Specimens were collected at Stations 10 (4 specimens), 11 (1), 12 (2), 13 (2), 14 (3), 15 (1), 16 (1), 17(3), 18 (4), 19 (1), 26 (4), 31 (3).

Cnemidophorus hyperythrus schmidti

Walker and Taylor (1968) in their preliminary treatment of the geographical variation among the "hyperythrus-like" populations of Baja California lacked sufficient material from Central Baja California to determine the variation and distribution of *schmidti*. The specimens collected in this study possess a single mid-dorsal line, forked anteriorly, which is characteristic of *schmidti* (Lindsdale, 1932; Murray, 1955). Data concerning scutellation and pattern of those specimens are summarized and compared to similar data for *hyperythrus* and *beldingi* in Table 4.

Murray (1955) indicated that *schmidti* could readily be distinguished from *hyperythrus*, the southern race, by the arrangement of the mid-dorsal lines. Separation of *schmidti* from *beldingi*, the northern population, is based presently on the number of supraoculars separated from the frontal by granules and less consistently by the presence of two mid-dorsal stripes (Table 4). My data concerning the degree to which the supraoculars are separated from the frontal by granules show that this character is of little diagnostic value when considered alone (Table 4). An apparent diagnostic difference among the three populations is the number of granules around mid-body, intermediate in *schmidti* (Table 4).

THIS PAGE IS LOCKED TO FREE MEMBERS
Purchase full membership to immediately unlock this page

FORGOTTEN BOOKS

FULL MEMBERSHIP

797,885 Books!
All you can read
for only
\$8.99/month

Continue

*Fair usage policy applies



The specimens, all adults, showed a daily activity cycle and occupied habitats similar to those previously recorded for the species (Bostic, 1968).

Scutellation and counts for Central Desert specimens were as follows: granules around mid-body, $59.8 \pm 0.4(52-69)87$; granules separating paravertebral stripes, $8.4 \pm 0.1(6-12)89$; femoral pore scales, left, $13.6 \pm 0.1(11-16)87$, right, $13.5 \pm 0.1(11-16)78$. Specimens were taken at Stations 2 (5), 26 (28), 28 (4), 31 (3), 33 (3), 36 (15), 37 (2), 41 (38).



Figure 6. Station 38, San Javier Arroyo. Several *Bufo punctatus* tadpoles were collected from the small, shallow algae-covered pool of water in the foreground. Adult *B. punctatus* were particularly abundant, and many were observed in amplexus. A *Sauromalus australis* was collected from within a crevice of the granite-strewn west slope (see arrow). *Phyllodactylus xanti sloani* were also collected beneath the exfoliating slabs of granite rock.

Cnemidophorus tigris multiscutatus

This species was relatively common throughout the survey area, but difficult to collect. Individuals were most active during the mid-day hours, when they were frequently observed foraging from shrub to shrub. They preferred the soft soil (sand and decomposed granite) of the washes and arroyos to the compacted, rocky soil of the marine terraces.

Selected characters for the specimens collected are as follows: Postantebrachials granular in all but three individuals, which have these slightly enlarged; supraorbital semi-circles normal, except for two specimens in which they extend past the posterior margin of the frontal; anterior nasal not in contact with the second supralabial in all but eight lizards; fronto-parietal divided in all but one specimen; number of supraoculars 4-4, except for seven specimens which have 5-5, 4-5, or 4-3 supraoculars; granules around body, $90.6 \pm 0.7(82-104)48$; femoral pore scales (left), $20.0 \pm 0.2(17-23)69$, S.D. 1.51; femoral pore scales (right), $19.9 \pm 0.2(16-23)70$, S.D. 1.58. Specimens were obtained at Stations 2 (1), 5 (4), 8 (11), 9 (2), 15 (1), 16 (1), 18 (1), 19 (1), 20 (13), 21 (2), 26 (14), 31 (8), 33 (2), 36 (8), 38 (2).

Coleonyx variegatus abbotti

These specimens agree closely with Klauber's (1945) original description, confirm the presence of the race in the Central Desert, and support Klauber's (1945) tentative assignment of a damaged specimen at Calmallí, seven miles NW of El Arco, to this subspecies. One individual was found beneath a small slab of shale on the SW slope of a clay-like foothill (Sta. 1), and two were collected beneath the basal leaves of dead *Agave* at Station 38.

Crotaphytus collaris

One specimen from Station 20, an adult male, represents the first recorded occurrence of *Crotaphytus collaris* west of the peninsular divide (Van Denburgh, 1922: 109; Smith and Taylor, 1950: 92).

The collecting station, Mesa de San Carlos, is a broad table-topped mountain near the coast, which rises to an altitude of from 422 to 739 meters. The above individual was observed foraging among large basaltic rocks on the edge of the mesa at approximately 1400 hrs. Another *C. collaris* was observed basking at 1730 hrs. on a small rock, part of a large basaltic rock outcrop, surrounded by low shrubs on the mesa proper.

Crotaphytus wislizeni copeii

A single juvenile from Station 20 agrees in scutellation and pattern with Banta and Tanner's (1968) account of the race. It was foraging in the late afternoon in a sandy wash thickly overgrown with xeric vegetation.

Gerrhonotus multicarinatus ssp.

Table 5 shows that the Central Desert specimens agree closely with *G. paucicarinatus* in degree of keeling and in some details of pigmentation. They appear more like *G. m. webbi* in numbers of longitudinal dorsal scale rows, and dorsal pattern; they have an intermediate position between *paucicarinatus* and *webbi* in numbers of transverse dorsal scale rows, degree of keeling and numbers of keeled temporal scale rows, lateral fold pigmentation and ventral markings. Coloration and over-all pattern among the individuals show considerable variation. Some resemble *paucicarinatus* and others *webbi*. Individual counts and measurements of the Central Desert specimens appear in Tables 6 and 7.

The above evidence suggests intergradation between *G. paucicarinatus* and *G. multicarinatus*. However, since a gap of about 250 miles separates these populations, it would be premature to make a formal nomenclatural change at this time.

The Pacific coastal strand is suitable for the southern dispersal of *G. multicarinatus*. Similarly, *G. paucicarinatus*, once believed to occur only in the highland area of the Cape Region, has now been recorded in the lowland area of the Cape (Richmond, 1965), and may have dispersed farther northward along the Pacific Coast where cool, moist environments suitable for anguids prevail.

Savage (1960) surmised that *paucicarinatus* separated from *multicarinatus* during a Pleistocene glacial maximum, but whether this isolation has resulted in ecological and/or reproductive isolation is unknown. The Vizcaino Desert is a possible barrier preventing their contact. From here south through the Magdalena Plains region, coastal precipitation is unpredictable, and often a summer phenomenon.

These specimens together with a specimen of *G. multicarinatus* ssp. from the Pacific coast west of Punta Prieta (Bogert and Porter, 1967: 15) are the first of *Gerrhonotus* from the Central Desert. Six were collected beneath dead or partially dead *Agave*, and two beneath pieces of tin at the abandoned settlement of Las Palomas. None of the examined females, collected in July, had enlarged yolk-laden ova or oviducal ova, but the oviducts in all were highly vascularized and convoluted.

Specimens were obtained at Stations 31 (1), 33 (3), 36 (3), and 38 (1). Additional speci-

mens examined—two *G. multincarinus* ssp. [SDSNH 45016, 24 December 1969, Sta. 31; American Museum of National History (AMNH) 75765, 22 April 1956, 5 mi. NE of Punta Santa Rosalia]; 18 *G. paucicarinus* from the Cape Region of Baja California (SDSNH 45006-45010, 45033, 45095-45098, 45100-45101, 45103-45106, 53057-53058).

Table 5. Comparisons between adult *Gerrhonotus paucicarinus*, *G. multincarinus* ssp., and *G. multincarinus webbi*.

Character	<i>G. paucicarinus</i>	<i>G. m.</i> ssp.	<i>G. m. webbi</i> ²
Average Snout-vent length	130	94.6	135 (n = 35)
Scutellation			
Dorsal Scale Rows			
Transverse	50.7(50-51) 10 ¹ 50.1(46-54) 18	46.2(45-50) 9	41.5(38-45) 44
Longitudinal	15.4(14,16) 10 ¹ 16.2(16,18) 18	14	14
Ventral Scale Rows			
Transverse	62.7(60-64) 10 ¹ 64.1(60-67) 18	64.6(62-68) 9	63.2(60-66) 44
Longitudinal	12 ¹ 12.1(12,14) 18	12	12
Keeling			
Temporals	None	Upper one to two rows faint or none.	Upper two rows or more.
Dorsal Rows	11.2(8-12) 18	11.4(10-14) 9	14
Upper Arm	None	None	Three rows or more.
Lower Arm	None	None	Average 2.8 ³
Tail	6-8	6-10	Eight plus several lateral rows.
Pigmentation			
Dorsal Head Spotting	Present (distinct)	Present (distinct-faint)	Absent (normally)
Eye Color	Unknown to me.	Yellow	Yellow
Temporal Eye Stripe	Distinct	Distinct	Faint
Labials	Normally distinctly banded with alternate black and white markings.	Faintly to distinctly edged with black.	Unicolor or the supralabials may be faintly edged with black.
Body Bands	11.1 (n = 10) when complete, but often bands are incomplete dorsolaterally. White markings are reduced laterally and usually absent mid-dorsally.	11.1(10-14) 9; Moderately indented with white markings on fifth or sixth scale row above lateral fold. The white mid-dorsally is usually indistinct.	10.6(9-13) 38; deeply indented with distinct white markings on fifth scale row above lateral fold and in middle of back.
Lateral Fold	Ground color predominates with narrow black lines.	Ground color predominates with large whitish spots distinctly outlined and composed of groups of white scales; black markings when present faintly diffuse.	Ground color predominates with scattered white spots but no black markings.
Ventral Markings	Along middle of longitudinal scale rows forming distinct longitudinal lines in most.	Along middle of longitudinal scale rows forming distinct to faint longitudinal lines.	Along middle of longitudinal scale rows forming faint longitudinal lines in most.

¹From Fitch (1938) ²From Fitch (1938) except where noted. ³From Murray (1955)

THIS PAGE IS LOCKED TO FREE MEMBERS
Purchase full membership to immediately unlock this page

DELVE INTO FANTASY, MAGIC, MYTHOLOGY & FOLKLORE

Forgotten Books'
Full Membership gives
access to 797,885 ancient
and modern, fiction and
non-fiction books.

Continue

*Fair usage policy applies

Phrynosoma coronatum

Two active specimens were collected on a flat, sandy substrate sparsely covered with low shrubs, and one was collected at 0650 hrs. by raking the sand beneath a hummock covered with ragweed; it was relatively sluggish and made no attempt to elude capture. These specimens were taken at Stations 9 (1), 14 (1), and 41 (1).

Phyllodactylus xanti sloani new subspecies

Holotype.—Adult female (Fig. 7), SDSNH 45895, collected 23.5 miles SE of El Rosario (29°48'N, 115°33'W), Baja California del Norte, Mexico, from a crevice in a block of shale by Thomas Cozens on 31 March 1969.

Paratypes.—All seventeen paratypes collected are from Baja California del Norte, Mexico: SDSNH 45896, Sta. 9; SDSNH 45897-45898, Sta. 25; SDSNH 45899-45900, Sta. 26; SDSNH 45901-45907, Sta. 31; SDSNH 45908, Sta. 33; SDSNH 45909-45912, Sta. 38.

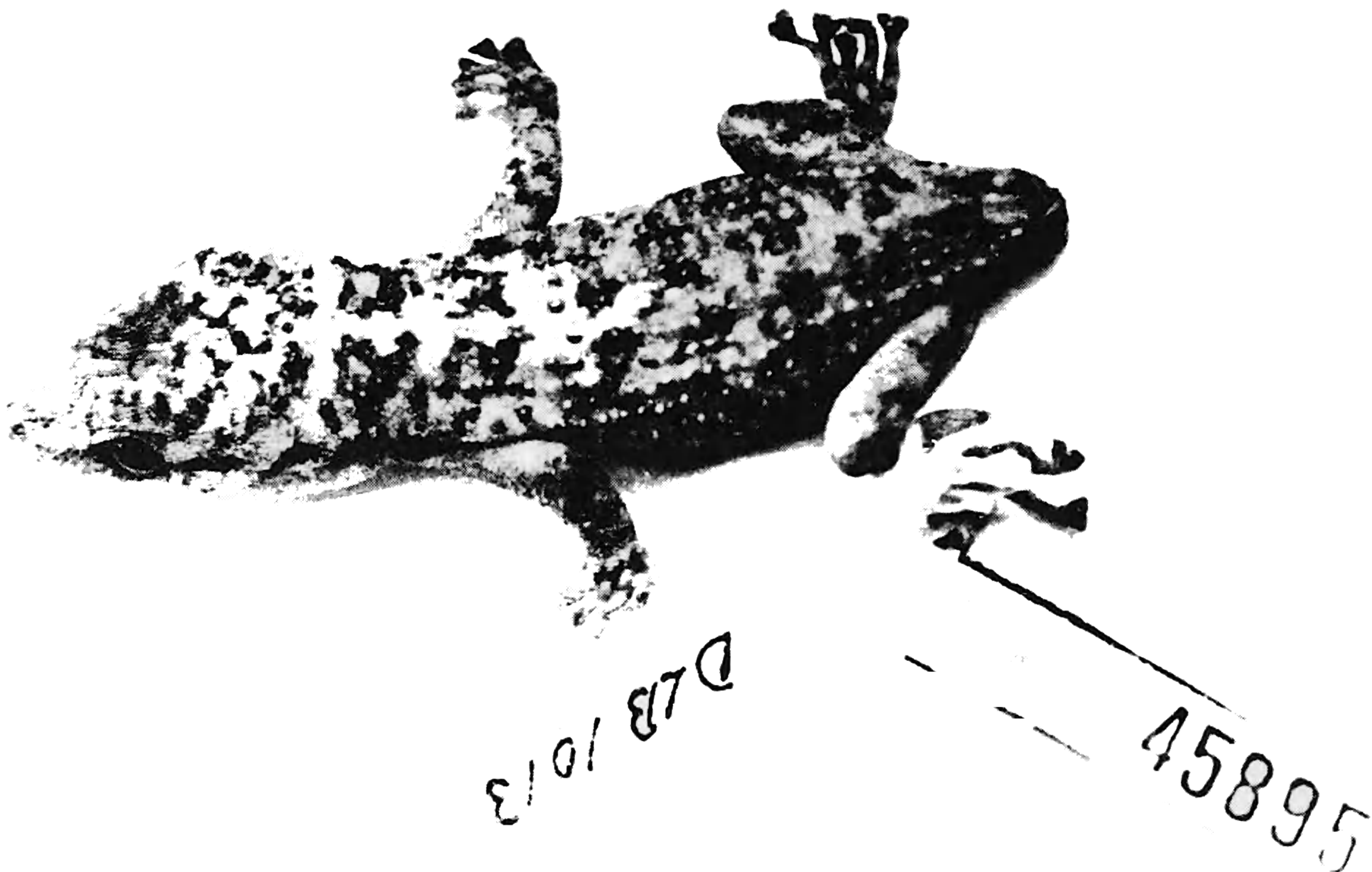

Figure 7. Holotype (SDSNH 45895) of *Phyllodactylus xanti sloani*.

Diagnosis.—This race differs from all other races, except *nocticolus*, confined to southeastern California and the eastern desert regions of Baja California, and *angulus*, occurring on Islas Salsipuedes and San Lorenzo Island, Gulf of California, by the absence of thigh tubercles (see Dixon, 1969:79.1-79.2, for diagnostic accounts of the races of *P. xanti*); from *angulus* in larger snout-vent length (51.1mm vs. 43.8mm), less numerous mid-orbital scales (18.0 vs. 20.5) and fewer paravertebral tubercles from axilla to groin (20.4 vs. 23.0) and from rear of head to base of tail (37.8 vs. 40.0); from *nocticolus* in less numerous longitudinal rows of ventral scales (27.2 vs. 35.2) and fewer tubercles in a paravertebral row between axilla and groin (20.4 vs. 23.0).

Description of holotype.—Rostral twice as wide as high, its dorsal edge with two rectangular internasals, their median edges in broad contact, bordered posteriorly by five granules and postnasal on each side; nostril surrounded by rostral, internasal, labial, and two postnasals; its ventral edge in contact with labial; slight depression between internasals and in frontal region; 20 scales between eye and nostril; posterior dorsolateral loreals three to four times larger than interorbital scales; 15 scales across snout between second labials,

17 between third labials; 12 scales between anterior edge of orbits; 20 interorbital scales; eye large, contained in snout length approximately one and one-half times; eyelid with two rows of granules and one larger outer row of scales, the latter with seven posterior scales bearing spines; diameter of ear contained in diameter of eye slightly less than two times; ear opening not denticulate, anterior border with rounded and slightly pointed scales, posterior margin with smaller rounded scales; top and rear of head granular, with faintly keeled, larger, intermixed tubercles; 12 supralabials, seventh to center of eye; 11 infralabials, fifth to center of eye; mental lyre-shaped, length and width equal; postmentals followed by a transverse row of eight scales, followed by a second row of 12 smaller scales; postmentals contacting first labial on right and left sides.

Dorsum with 12 longitudinal rows of enlarged, keeled, somewhat flattened tubercles, 11 rows reaching head, six at base of tail; 39 paravertebral tubercles, 24 between axilla and groin; two median rows of enlarged tubercles separated from each other by two and three rows of granules; each tubercle of enlarged dorsal series separated from preceding tubercle by one to three granules; three postanal tubercles on either side of anus, well differentiated, rounded; 35 scales across venter, 72 from gular region to anus.

Ventral, antero-dorsal surfaces of limbs with large circular scales, postero-ventral surfaces granular; lower arm and leg granular, with scattered larger, keeled tubercles intermixed; lamellae formula for left hand 7-9-10-11-8 (undivided 2-6-7-8-7), left foot 6-10-12-13-11 (undivided 5-8-8-12-6); claws short, tip barely visible when viewed from below; terminal pads rounded at tips; tail missing.

Measurements in mm.—Snout-vent length 53; headwidth 10.7; head length 13.9; axilla-groin length 24.4.

Color in alcohol.—Mid-dorsum ground color pinkish-tan; dorso-lateral surfaces blue-gray. Venter light pinkish-tan; dorsum with six reddish-brown broken crossbands, slightly narrower than ground color interspaces; dorsal and lateral surfaces of head spotted with light brown; area posterior of eye orbits, but anterior to first dorsal band, spotted with light brown on a tan ground color; dorsal surfaces of limbs with brown spots; tips of enlarged dorsal tubercles cream, brown, or brown and cream.

Variation.—No sexual dimorphism in size, color, or pattern is evident. Counts and measurements are as follows: Snout-vent length $51.1 \pm 0.6(32-61)17$; enlarged series of dorsal tubercles, $11.8 \pm 0.3(9-14)17$; postmental border scales, $7.3 \pm 0.2(6-10)18$; nostril to eye scales, $10.5 \pm 0.2(9-12)18$; scales bordering internasals, $6.8 \pm 0.1(5-8)18$; interorbital scales, $18.0 \pm 0.3(15-20)18$; third labial scales, $16.4 \pm 0.2(15-18)18$; lamellae beneath fourth toe, $12.5 \pm 0.2(11-14)18$; scales across venter, $27.1 \pm 0.9(21-35)17$; number of paravertebral tubercles, $37.8 \pm 0.7(32-40)17$; axilla to groin, $20.4 \pm 0.3(17-24)16$. Of the 18 specimens, all but one have the postmentals contacting two labials on each side. There are two postmentals in all but two individuals, which have three. The number of interorbital scales is always equal to or more than the number of scales across the snout between third labials. The color pattern varies from incomplete, irregular bands, and spotting to complete bands on the dorsum (Fig. 8). The ground color ranges from reddish-brown to gray-brown. The venter of all specimens is immaculate.

Remarks.—These specimens are the first of *P. xanti* from the Pacific slope of the peninsula (see Dixon, 1966, Fig. 1). All individuals were collected beneath exfoliating slabs and in fracture crevices of granite and shale, predominately the latter (see Fig. 6). This subspecific epithet honors Allan J. Sloan, Curator of Reptiles and Amphibians, San Diego Museum of Natural History, whose assistance, enthusiasm and support were largely responsible for making this survey a reality.

Range.—Known from 23.5 miles SE of El Rosario ($29^{\circ}48'N$, $115^{\circ}33'W$) to San Javier

(28°32'N, 114°05'W) on the west coast of the peninsula.

Specimens examined.—The 18 specimens examined are listed under type and paratypes.

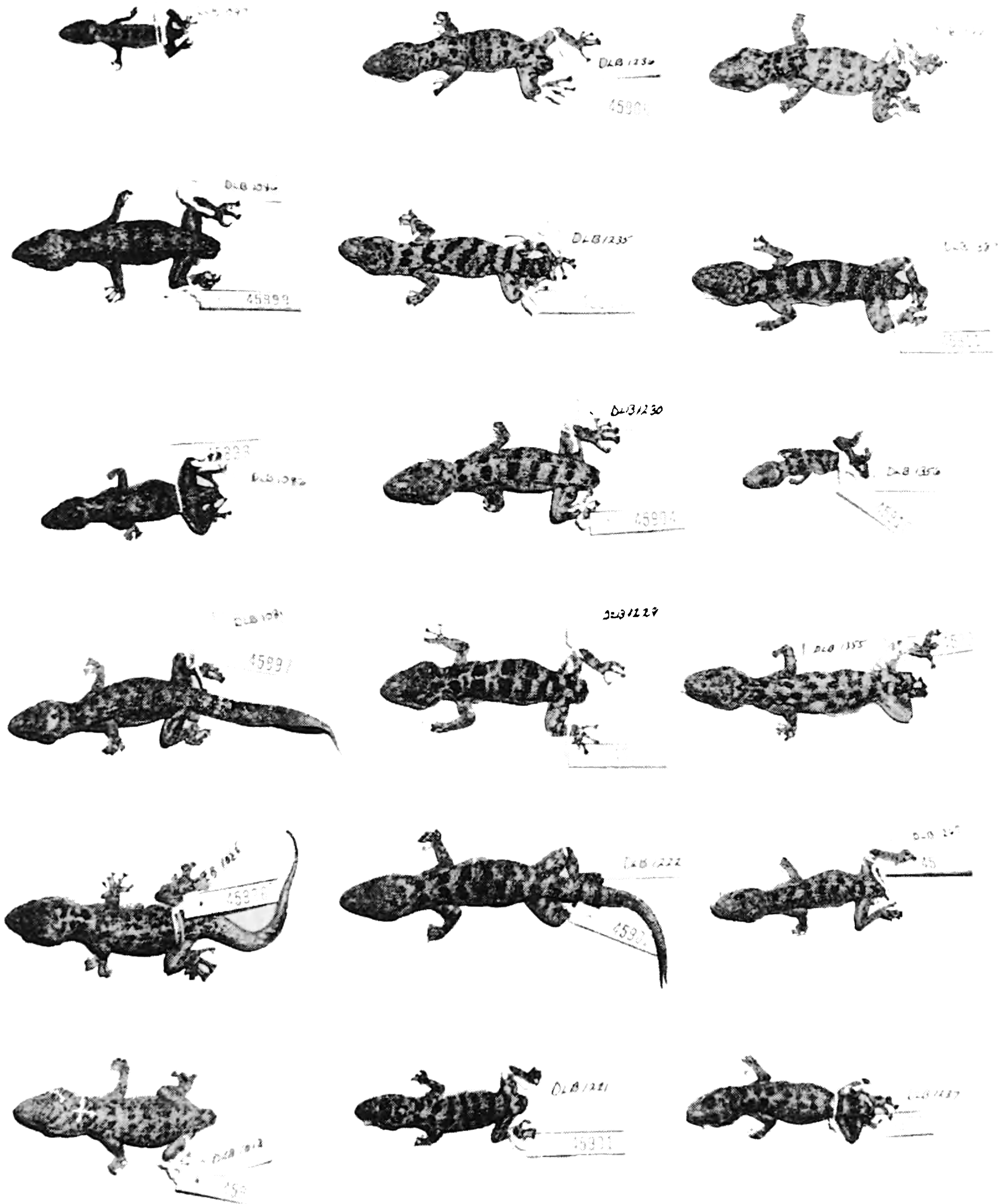

Figure 8. Dorsal variation among specimens of *Phyllodactylus xanti sloani* collected along the Pacific coastal strand of the Central Desert of Baja California del Norte, Mexico.

Sauromalus australis

An adult male was collected from deep within a crevice on the afternoon of 12 July 1969 approximately 15 yards up the steep granite-strewn west slope of Arroyo San Javier (Station 38; see Fig. 6).

Despite two additional days working suitable habitats in and around the arroyo, no other *Sauromalus* were observed. That this specimen was not a "waif," however, was indicated by large amounts of dried fecal material, and by the observation of similar large lizards by a resident rancher, Señor Lopez of "Mi Ranchita," who stated that chuckwallas could be found about three miles to the east of his ranch.

THIS PAGE IS LOCKED TO FREE MEMBERS
Purchase full membership to immediately unlock this page

FORGOTTEN BOOKS

FULL MEMBERSHIP

797,885 Books!
All you can read
for only
\$8.99/month

Continue

*Fair usage policy applies



Table 8. Scutellation and measurements of adult *Sceloporus magister rufidorsum*.

	Phelan and Brattstrom (1955)	Central Desert Specimens	
		Males	Females
Snout-vent length	131.0-maximum	110.0±2.1(97-119)12 S.D. = 7.4	96.2±1.7(93-105)6 S.D. = 4.2
Ratio, tail: snout-vent	1.4(1.2-1.5)6	1.2±0.03(1.0-1.4)12 S.D. = 0.1	1.3±0.04(1.2-1.3)6 S.D. = 0.1
Dorsal scales	29.8(29-31)8	29.0±0.2(28-30)11 S.D. = 0.7	29.3±0.5(28-30)3 S.D. = 0.9
Femoral pores	17.9(15-20)14	18.6±0.4(16.5-20.0)12 S.D. = 1.5	17.5±0.5(16-19)6 S.D. = 1.2
Gular scales	15.9(15-18)8	18.4±0.4(17-20)12 S.D. = 1.2	18.6±0.3(17-19)6 S.D. = 0.7
Supralabials	4.4(4-5)13	4.1±0.1(4.0-4.5)12 S.D. = 0.2	4.1±0.1(4.0-4.5)5 S.D. = 0.2
Infralabials	6.2(5-7)13	6.2±0.1(6.0-6.5)12 S.D. = 0.2	6.5±0.1(6.0-7.0)5 S.D. = 0.3
Supraoculars	5.3(5-6)13	5.5±0.2(5-6)5 S.D. = 0.4	5.7±0.9(5-6)5 S.D. = 0.4
Circumorbitals	5.1(3-6)14	6.9±0.4(6.0-10.5)12 S.D. = 1.3	8.1±0.9(5-11)5 S.D. = 2.0
Lamellae, fourth toe	—————	22.7±0.4(20-25)12 S.D. = 1.4	22.3±0.3(21.0-23.5)6 S.D. = 0.8
Auricular lobules	—————	5.5±0.2(4.5-6.0)12 S.D. = 0.7	5.5±0.3(4.5-6.0)5 S.D. = 0.6
Ventrals	—————	39.1±0.8(35-43)11 S.D. = 2.6	40.2±0.6(39-42)6 S.D. = 1.4

16.8±0.4(15-18)8, S.D. = 1.0; infralabials, 5.8±0.1(5.5-6.0)8, S.D. = 0.4; supraoculars, 5.0±0.2(4-6)8, S.D. = 0.5; circumorbitals, 6.1±0.2(5.0-6.5)7, S.D. = 0.6; lamellae, fourth toe, 20.6±0.9(15-23)8, S.D. = 2.4; auricular lobules, 5.6±0.2(5-6)8, S.D. = 0.5; ventrals, 38.7±0.7(35-41)7, S.D. = 1.8.

Urosaurus microscutatus

All individuals were initially observed basking or foraging in rocky areas and when approached generally retreated to rock crevices. The collected specimens, from Stations 10(2), 20(1), 33(1) and 38(3), represent over half of all *Urosaurus* observed during the survey.

Uta stansburiana

Side-blotch lizards were the most frequently observed reptile in the Central Desert. They occupied every conceivable habitat, and were generally the first and last reptiles observed each day. Specimens were collected at Stations 2(14), 5(2), 6(1), 8(2), 9(6), 10(7), 14(1), 16(2), 18(1), 20(8), 21(16), 23(1), 24(3), 25(1), 26(19), 28(5), 29(1), 30(1), 31(10), 33(7), 36(5), 37(7), 38(4), 39(4), 40(3), and 41(46).

Xantusia vigilis wigginsi

This species was most commonly found beneath the basal leaves of dead *Agave* and less frequently in or under dead decaying stems of cirio and *Yucca*. Specimens were taken at stations 2(7), 5(4), 26(4), 31(8), 33(8), and 36(1).

These specimens fill the distributional gap of approximately 85 miles between the northernmost collecting locality, 23.5 miles north of Punta Prieta, Baja California del Norte, recorded for this race (Savage, 1952), and a single specimen collected near El Rosario which

Savage stated seemed "to be nearer *wigginsi* than to the northern form," (*X. v. vigilis*).

SNAKES

Chilomeriscus cinctus

An adult male was collected at Station 38 by raking through the base of a small hummock of sand. A *Phrynosoma coronatum* and a *Sceloporus magister* were collected in the same fashion, but beneath the sand of a larger hummock covered with ragweed.

Counts and measurements for this individual are as follows: ventrals, 124; subcaudals, 25; dorsal body bands, 22; tail bands, 5; and dorsal scale rows, 15-15-13.

Crotalus enyo enyo

A juvenile specimen was collected at Station 3 beneath a dead *Agave*. Scutellation and pattern agree with Klauber's (1931b) account of the nominal race.

Crotalus ruber ruber

The number of body blotches and the scale counts of these specimens fall within the parameters established for the race by Klauber (1964: Table 2:7).

Crotalus ruber occupied a diversity of macrohabitats; one was observed in a coiled position about 10 yards above the high tide mark of a cobblestone beach and another in a coiled position beneath an ocotillo in bloom in a sandy, dune-like environment. Specimens were collected at Stations 2(1), 3(1), 6(1), 7(1), 8(1), 21(1), 22(1), 38(1), 41(1).

Crotalus viridis helleri

A juvenile specimen collected at Station 41 is distinctly light colored with a sharply defined pattern. It was observed at 0920 hrs. coiled beneath a small, sparsely branched ragweed shrub at the fringe of an isolated sandy dune area.

Details of pattern and scale counts agree with those summarized by Klauber (1964, Table 2:7) for the race.

Hypsiglena torquata klauberi

An active immature female was collected at 1710 hours beneath a dead *Agave* in an eroded, sandy-bottomed wash (Sta. 2). Scutellation, coloration and pattern are similar to those reported by Tanner (1944) for the race.

Lichanura roseofusca gracia

Compendia dealing with North America reptiles list two species of *Lichanura*, *trivirgata* and *roseofusca*, the latter species represented by two races, *roseofusca* and *gracia*.

Klauber (1933) reported a specimen of rosy boa from Guaymas, Sonora, Mexico, that agreed exactly with *L. trivirgata* in coloration and pattern but more closely approached *L. r. gracia* in scutellation. He remarked that perhaps we might be dealing with three subspecies, *trivirgata*, *gracia* and *roseofusca*. However, he did not suggest uniting the two species before additional material between Guaymas and southern Arizona and in central Baja California demonstrated intergradation.

Since Klauber's (1933) remark, additional specimens have been collected from these areas, but according to Gorman (1965) we still lack a basis for uniting the two species of *Lichanura* in view of the great uniformity of pattern of *trivirgata* throughout its known range, and the absence of obvious intergrades with *gracia*.

The Central Desert specimen from Station 38 is of particular interest since the locality is the southernmost for *Lichanura* in Baja California del Norte, and is only 100 miles from San Ignacio, the northernmost for *L. trivirgata*.

The Central Desert specimens appear to agree with *trivirgata* in dorsal and ventral counts, but more closely agree with *gracia* in all other counts (Table 9). In pattern and color-

ation there is close agreement with Klauber's (1931a) description of *gracia*. I tentatively, then consider these specimens to be *gracia*.

One boa, a mature male, was collected in a grain field shortly after it had been killed by a rancher (Sta. 4), and the other, an active female, was collected in the late afternoon from beneath the basal leaves of an *Agave* (Sta. 38).

Table 9. Scale characters of *Lichanura trivirgata* and *L. roseofusca*.

	<i>L. trivirgata</i>		<i>L. roseofusca</i> ²		Central Desert Specimens SDSNH Nos	
	Gorman ¹	Klauber ²	<i>gracia</i>	<i>roseofusca</i>	45957	4595
Dorsals	39.2(36-41)10	41.4(40-43)7	41.3(40-43)9	40.9(35-43)38	42	40
Ventrals	218.5(219-223)10	222.0(218-227)7	230.0(220-236)9	232.0(221-244)38	225	222
Caudals	45.0(42-49)10	44.0(42-46)7	46.0(42-49)9	47.0(39-51)38	46	43
Oculars	10.1(9-11)10	9.7(9-11)9	9.8(8-11)9	9.1(7-10)38	11-10	10
Supralabials	12.8(12-14)10	12.8(12-13)7	14.1(13-15)9	14.1(12-15)38	15	14
Infralabials	13.8(13-15)10	13.8(13-15)7	15.4(14-17)9	15.0(13-17)38	15	14-1

¹Data from Gorman, 1965

²Data from Klauber, 1931

Masticophis flagellum piceus

Specimens, all adult females, were taken at Stations 2(1), 9(1), and 28(1). One active individual was collected from within the hollow, dead stalk of an *Agave* at 1655 hrs. Another was collected at 1500 hrs. from beneath a large shrub in a sandy, eroded arroyo. The most active individual was first observed in early afternoon foraging on the leeward side of a large inland sand dune.

Phyllorhynchus decurtatus decurtatus

An adult male was collected at approximately 2000 hrs. as it crossed a sandy stretch of road at Station 35. Scutellation and counts are as follows: caudal blotches, 7; dorsal body blotches, 39; ventrals, 168; caudals, 36; snout-vent length, 367; and tail length, 58.

Pituophis melanoleucus annectens

This adult female was killed by a farmer who saw it foraging in a grain field (Sta. 4).

Scutellation and other counts, except for the ratio of total length to tail length, fit the parameters established by Klauber (1946) for the race. The aforementioned ratio is .107 (total length 2565mm/tail length 265mm) considerably less than the .155 reported by Klauber (1946) for female *annectens*, which he states is probably the longest tailed of all the gopher snakes.

Pituophis melanoleucus bimaris

One specimen, an adult male from Sta. 21, was observed at 0930 hrs. as it foraged in a sandy area studded with pitahaya. It attempted to elude capture by retreating down a mammal hole. The other *bimaris*, an active, immature female from Station 33, was collected from beneath the basal leaves of a dead *Yucca* on a coastal foothill. This individual, as indicated by the bulge in its stomach, had recently fed on a small woodrat (*Neotoma*).

Salvadora hexalepis klauberi

One specimen was collected in late afternoon while basking on a dirt road (Sta. 5). The other individual was collected at 1630 hrs. as it foraged in an open sandy area (Sta. 36).

Scutellation, pattern and counts generally fit Klauber's (1946) description of the race. The exceptions are as follows: SDSNH 45953 has 241 ventrals, much lower than the range of 253-257 given by Klauber, and SDSNH 45954 has a tail-to-total-length ratio of

THIS PAGE IS LOCKED TO FREE MEMBERS
Purchase full membership to immediately unlock this page

DELVE INTO FANTASY, MAGIC, MYTHOLOGY & FOLKLORE

Forgotten Books'
Full Membership gives
access to 797,885 ancient
and modern, fiction and
non-fiction books.

Continue

*Fair usage policy applies

distribution, ecological associations, and tolerances, appear to be contiguous with the peninsular populations. The scarcity of favorable habitats within the area surveyed preclude their occurrence elsewhere.

Analysis of the distribution of *Gerrhonotus multicarinatus* spp., contrary to Savage's (1960) interpretation, indicates a southward expansion of its range since glacial maximum via the cool, moist coastal corridor. The same may be true for other temperate-tolerant types such as *Tantilla planiceps eiseni*, *Coleonyx variegatus abbotti* and *Lichanura roseifusca gracia*. The ranges of other temperate adapted forms from the Cape refugium, such as *Gerrhonotus paucicarinatus* may be expanding northward via the Pacific coastal corridor.

The *Crotaphytus collaris* of Mesa de San Carlos appear to represent an isolated population. The discontinuity of favorable habitat and climatic conditions within the survey area, excluding the Sierra Colombia with summits near 762 meters, together with the apparent distributional gap between this population and the peninsula's east coast populations seem to support this view.

San Carlos Mesa is about 15 miles long in a northwestern and southeastern direction by six miles wide and rises to an altitude of from 422 to 739 meters. The basaltic rock outcrops around the edge and on the top of the mesa provide suitable habitat for *C. collaris*. The mesa proper is a favorable habitat for the species. In contrast to the surrounding lowlands and foothills, it is subject to a greater duration and intensity of solar radiation, and concomitantly less frequent and shorter durations of coastal cloud cover and fog.

Phyllodactylus xanti sloani probably represents a marginal population of the mainland stock that recently immigrated to the Pacific slope via the foothills of the southern extremity of the Sierra de San Pedro Mártir occupying marginal, but suitable habitats to the north and south.

ACKNOWLEDGEMENTS

I wish to express my sincere gratitude to the Belvedere Scientific Fund of San Francisco for their financial support of this survey.

I am indebted to Thomas Cozens for his field and laboratory assistance, and to Margery Stinson for her laboratory and office assistance.

To Glen Contreras and Dennis Roberts for their able field assistance, I am especially grateful.

For the generous help, interest and encouragement of Allan J. Sloan, Curator of Herpetology, San Diego Natural History Museum, I am particularly indebted.

Special thanks are extended to Reid Moran, Curator of Botany at the SDNHM for his identification of the plants; to Elsie Arena for technical assistance; Bill Hite, Victor Limon and John Waldrup for field assistance; to Mike Langdon and DeDe Miller for their illustrations of Fig. 1 and Figs. 2,3 and 4, respectively; to Ted Karounos for Figs. 7 and 8; to Mr. and Mrs. Robert Eckhart for office and laboratory assistance; to Richard P. Phillips, for his letters of introduction which proved to be invaluable assets; to Richard G. Zweifel, American Museum of Natural History, for the loan of *Gerrhonotus* from Baja California; to Charles Coutts and Eugene Stevens, Palomar College, for placing the facilities of the Life Sciences Division at my disposal; and to Leon Rector for his excellent preparation and maintenance of the vehicles used in the survey.

I am particularly grateful to James R. Dixon, Richard Ethridge, Reid Moran, Clifford H. Pope, Allan J. Sloan and Ira L. Wiggins for their sound editorial comments and criticisms of the manuscript.

My sincerest appreciation is extended to Mrs. Norrine Keese and Mrs. Sophie Bartlett who typed the final body of the manuscript, and the tables, respectively.

I am also thankful for the help and cooperation of Dr. Rodolfo Hernandez Corzo, Director General de la Fauna Silvestre de la Secretaria de Agricultura y Ganaderia, who issued the collector's permit.

LITERATURE CITED

Arnold, B. A.

1957. Late pleistocene and recent changes in land forms, climate, and archaeology in central Baja California. Univ. California Publ. Geogr. 10(4): 201-318.

Aschmann, H.

1959. The central desert of Baja California: Demography and ecology. Ibero-Amer. 42. Univ. California Press, Berkeley. 282 p.

Banta, B. H., and W. W. Tanner.

1968. The systematics of *Crotaphytus wislizeni*, the leopard lizards (Sauria: Iguanidae). Part II. A review of the status of the Baja California peninsular populations and a description of a new subspecies from Cedros Island. Great Basin Nat. 28(4): 183-194.

Bogert, C. M., and A. P. Porter.

1967. A new species of *Abronia* (Sauria, Anguinae) from the Sierra Madre del Sur of Oaxaca, Mexico. Amer. Mus. Novitates 2279:1-21.

Bostic, D. L.

1968. Thermal relations, distribution, and habitat of *Cnemidophorus labialis* (Sauria: Teiidae). San Diego Soc. Nat. Hist., Trans. 15(3): 21-30.

Burt, C. E.

1931. A study of the teiid lizards of the genus *Cnemidophorus* with special reference to their phylogenetic relationships. U.S. Natl. Mus. Bull. 154: 1-286.

Dixon, J. R.

1966. Speciation and systematics of the Gekkonid lizard genus *Phyllodactylus* of the islands of the Gulf of California. California Acad. Sci. Proc. 33(13): 415-452.
1969. *Phyllodactylus xanti*. Cat. Amer. Amphibians Reptiles: 79.1-79.2

Fitch, H. S.

1938. A systematic account of the alligator lizards (*Gerrhonotus*) in the western United States and Lower California. Amer. Midland Nat. 20(2): 381-424.

Gorman, G. C.

1965. The distribution of *Lichanura trivirgata* and the status of the species. Herpetologica 21(4): 283-287.

Hastings, J. R. (Ed.) and R. R. Humphrey (Ed.).

1969. Climatological data and statistics for Baja California. Technical reports on the meteorology and climatology of arid regions, no. 18 Tucson: Univ. Arizona Atmos. Phys.

Hastings, J. R., and R. M. Turner.

1964. Climatological data for Baja California. Technical reports on the meteorology and climatology of arid regions, no. 14. Tucson: Univ. Arizona Atmos. Phys.

1965a. Seasonal precipitation regimes in Baja California, Mexico. Geografiska Annaler 47 Ser. A: 204-223.

1965b. The changing mile; an ecological study of vegetation change with time in the lower mile of an arid and semi-arid region. Univ. Arizona Press, Tucson. 217 p.

Jaeger, E. C.

1957. The North American deserts. Stanford Univ. Press. 308 p.

Jameson, D. L., J. P. Mackey, and R. C. Richmond.

1966. The systematics of the Pacific tree frog, *Hyla regilla*. California Acad. Sci., Proc. 33(19): 551-620.

Johnson, S. R.

1965. An ecological study of the chuckwalla, *Sauromalus obesus* Baird, in the western Mojave Desert. Amer. Midland Nat. 73(1): 1-29.

Klauber, L. M.

- 1931a. A new subspecies of the California boa, with notes on the genus *Lichanura*. San Diego Soc. Nat. Hist., Trans. 6(20): 305-318.

1931b. *Crotalus tigris* and *Crotalus enyo*, two little known rattlesnakes of the southwest. San Diego Soc. Nat. Hist., Trans. 6(24): 353-370.

1933. Notes on *Lichanura*. Copeia (4): 214-215.

1945. The geckos of the genus *Coleonyx* with descriptions of new subspecies. San Diego Soc. Nat. Hist., Trans. 10(11): 133-216.

1946. The gopher snakes of Baja California, with descriptions of new subspecies of *Pituophis catenifer*. San Diego Soc. Nat. Hist., Trans. 11(1): 1-40.

1964. Rattlesnakes. Their habits, life histories, and influences on mankind. Univ. California Press. 2 vol.

Linsdale, J. M.

1932. Amphibians and reptiles from Lower California. Univ. California Publ. Zool. 38(6): 345-386.

McGinnies, W. G. (Ed.), B. J. Goldman (Ed.), and P. Paylore (Ed.).

1968. Deserts of the world. An appraisal of research into their physical and biological environments. Univ. Arizona Press. 788 p.
- Meigs, P.
1953. World distribution of arid and semiarid homoclimates. In Reviews of research on arid zone hydrology. Unesco, Paris Arid Zone Prog. 1: 202-210.
1966. Geography of coastal deserts. Unesco, Paris. Arid Zone Research 28: 140 p.
- Murray, K. F.
1955. Herpetological collections from Baja California. Herpetologica 11:33-48.
- Myers, C. W., and A. S. Rand.
1969. Checklist of amphibians and reptiles of Barrow Colorado Island, Panama, with comments on faunal change and sampling. Smithsonian Contrib. Zool. (10): 1-11.
- Nelson, E. W.
1921. Lower California and its natural resources. Natl. Acad. Sci. 16, First Memoir. 194 p.
- Phelan, R. L. and B. H. Brattstrom.
1955. Geographical variation in *Sceloporus magister*. Herpetologica 11(1): 1-14.
- Richmond, N. D.
1965. Distribution of *Gerrhonotus paucicarinatus* Fitch. Copeia (3): 375.
- Sauer, C. and P. Meigs.
1927. Lower Californian studies. I. Site and Culture at San Fernando de Velicatá. Univ. California Publ. Geog. 2(9): 271-302.
- Savage, J. M.
1952. Studies on the lizard family Xantusiidae I. The systematic status of the Baja California night lizards allied to *Xantusia vigilis*, with the description of a new subspecies. Amer. Midland Nat. 48(2): 467-479.
1960. Evolution of a peninsular herpetofauna. In symposium: The biogeography of Baja California and adjacent seas. Syst. Zool. 9(3-4): 184-212.
- Shaw, C. E.
1945. The chuckwalla, genus *Sauromalus*. San Diego Soc. Nat. Hist., Trans. 10(15): 269-306.
- Short, L. L., Jr., and R. Crossin.
1967. Notes on the avifauna of northwestern Baja California. San Diego Soc. Nat. Hist., Trans. 14(20): 281-300.
- Shreve, F.
1936. The transition from desert to chaparral in Baja California. Madroño 3: 357-264.
1942. The desert vegetation of North America. Bot. Rev. 8(4): 195-246.
- Shreve, F. and I. L. Wiggins.
1964. Vegetation and flora of the Sonoran Desert. Stanford, Stanford Univ. Press. I: 1-840.
- Smith, H. M. and E. H. Taylor.
1950. An annotated checklist and key to the reptiles of Mexico exclusive of the snakes. U.S. Natl. Mus. Bull. 199: 1-253.
- Tanner, W. W.
1944. A taxonomic study of the genus *Hypsiglena*. Great Basin Nat. 5(3-4): 25-92.
1966. The night snakes of Baja California. San Diego Soc. Nat. Hist., Trans. 14(15): 189-196.
- Tevis, L.
1944. Herpetological notes from Lower California. Copeia (1): 6-18.
- Van Denburgh, J.
1922. The reptiles of western North America. Occ. Papers California Acad. Sci. (10): 1-1028.
- Walker, J. M.
1966. Morphology, habitat and behavior of the teiid lizard. *Cnemidophorus labialis*. Copeia (4): 644-650.
- Walker, J. M. and H. L. Taylor.
1968. Geographical variation in the Teiid lizard *Cnemidophorus hyperythrus*. I. The *caeruleus*-like subspecies. Amer. Midland Nat. 80(1): 1-27.
- Wiggins, I. L.
1960a. Investigations in the natural history of Baja California. California Acad. Sci., Proc. 30(1): 1-45.
1960b. The origin and relationships of land flora. In symposium: The biogeography of Baja California and adjacent seas. Syst. Zool. 9(3-4): 148-165.

THIS PAGE IS LOCKED TO FREE MEMBERS
Purchase full membership to immediately unlock this page

FORGOTTEN BOOKS

FULL MEMBERSHIP

797,885 Books!
All you can read
for only
\$8.99/month

Continue

*Fair usage policy applies



**A NEW GENUS OF CHTHAMALIDAE
(CIRRIPIEDIA) FROM THE SOUTHEASTERN
PACIFIC ISLAND OF SAN AMBROSIO**

ARNOLD ROSS

TRANSACTIONS

**OF THE SAN DIEGO
SOCIETY OF
NATURAL HISTORY**

VOL. 16, NO. 11

26 OCTOBER 1971

THIS PAGE IS LOCKED TO FREE MEMBERS
Purchase full membership to immediately unlock this page

DELVE INTO FANTASY, MAGIC, MYTHOLOGY & FOLKLORE

Forgotten Books'
Full Membership gives
access to 797,885 ancient
and modern, fiction and
non-fiction books.

Continue

*Fair usage policy applies

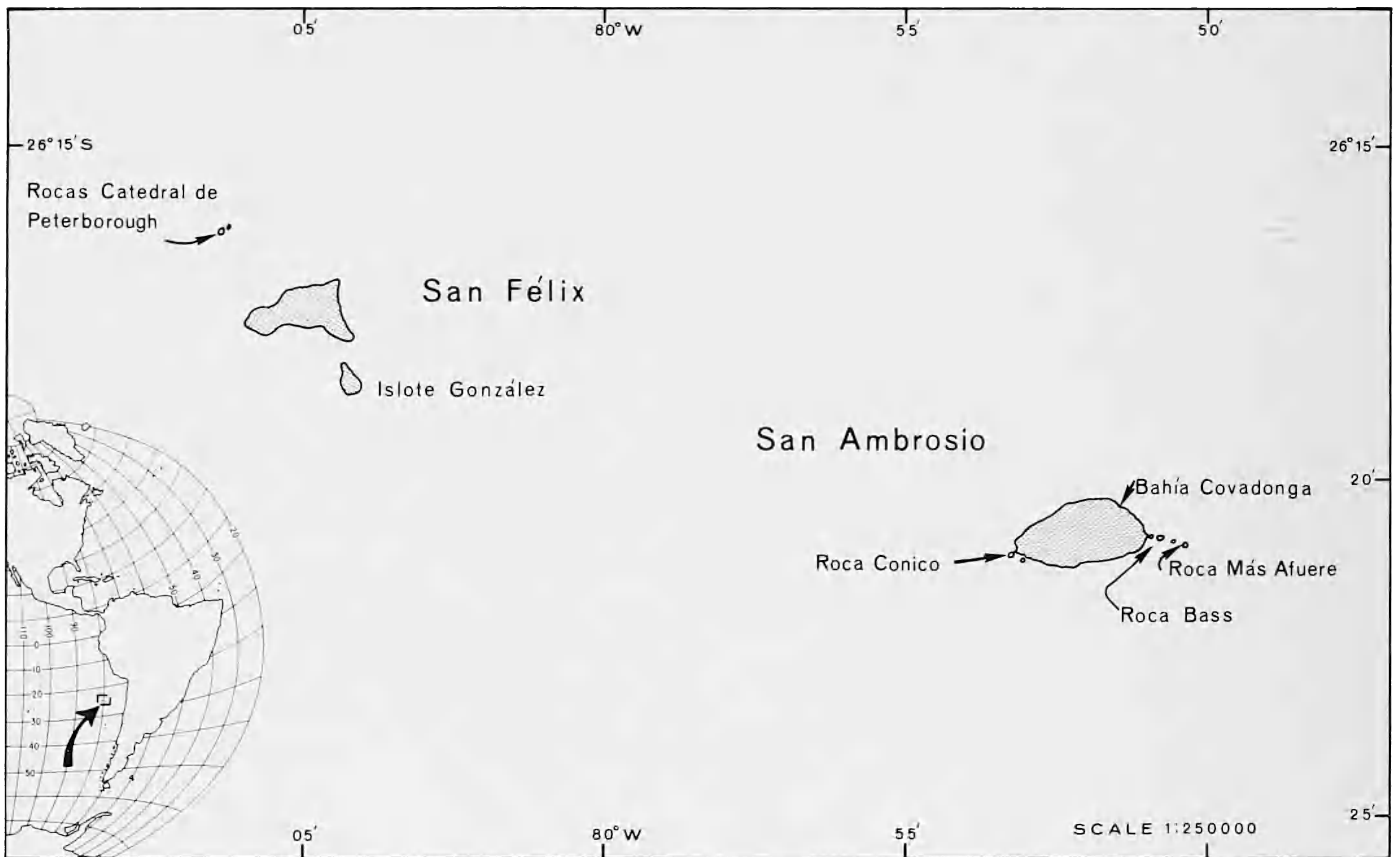

Figure 1. Map showing position of Isla San Ambrosio relative to other islands in the Desventurados group, Chile.

toward South America (Wyrcki, 1968: 131). Near Chile at about 50° S this water mass divides, one branch turning south and eastward around the tip of South America, the other flowing northward along the coast as the Peru Current (= Humboldt Current) or the Peru-Chile Current System. The offshore Desventurados Islands are under the influence of this current system. The Peru Current extends as far north as Ecuador and then swings west just south of the Equator to become part of the South Equatorial Current. The northward flow of the Peru Current, generally at 25° S, is divided into two components, the Peru Coastal Current and the Peru Oceanic Current, between which is a southward moving subsurface current, the Peru Countercurrent, which carries equatorial subsurface water as far as 22° S (Wyrcki, 1966: 59; 1968: 121).

The prevailing north-flowing currents argue for colonization of San Ambrosio from the southeast, much as the biota of the Juan Fernandez Islands, in the main, also appears to have been derived from South America. I have discounted a direct Australia-New Zealand origin of the Desventurados chthamalid largely because of the vast distance separating the two regions, the apparent absence of any living or extinct populations of chthamalids in the region between, and because the temperate Southeast Pacific chthamalids have their greatest affinity with the Tropical American fauna (Zullo, 1966: 142). *Elminius* and *Austrobalanus* in the southeastern Pacific, although seemingly good indicators of biogeographical affinities, are two groups that remain poorly known (the type species of *Austrobalanus* is apparently a six-plated tetracitid and the remainder true balanids; *Elminius* until recently contained two species referable to the tetracitid *Epopella* and the remaining two or three widely separated species offer no clues as to their origin [Ross, 1970: 9]).

Based on morphological and hydrographic evidence, this new chthamalid probably evolved from or shared a common ancestry with *Chthamalus cirratus* Darwin, 1854, which



Figure 2. View from the northwest of Isla San Ambrosio. Small prominence to the right of San Ambrosio is Roca Conico. Photo by R. M. Gilmore.

occurs commonly along the west coast of South America from the Chonos Archipelago in Chile (about 45° S) to Guayaquil, Ecuador ($2^{\circ} 13'$ S) (Pilsbry, 1916: 321; Nilsson-Cantell, 1957: 11).

Three possible modes of colonization are offered in what I believe to be increasing probability, 1) introduction by or through an agency of man, 2) larval colonization, and 3) adult colonization by natural drift or rafting. I have discounted the first because *Chthamalus* and its derivatives are essentially shore barnacles, although they are known to foul marine structures. Also, the evolutionary state of this new species argues for colonization prior to the origin of man in the new world. I also doubt that the islands were colonized by larvae, because the nauplii of *Chthamalus* and other balanomorphs in general lack the long tomentose flotation setae characteristic of pelagic species, and because the nauplii of intertidal barnacles probably remain in the plankton less than two weeks, which is apparently not long enough to reach San Ambrosio. The efficacy of natural rafting is well documented in the literature, and it appears most probable that colonization of San Ambrosio was effected by rafting.

As Crisp and Southward concluded (1953: 209), even narrow seas pose a barrier to animals that are predominantly intertidal. The relatively small size of the two major islands in the Desventurados Group (San Ambrosio—4 km long, 1 km wide; San Félix—3 km long, 1 km wide), and their great distance from the South American mainland, would tend to preclude repetitive colonization from the mainland. Many workers have remarked that in order to establish a viable population some minimum density is required. However, since there is good evidence that many species of *Chthamalus* are readily capable of self fertilization under certain conditions (Barnes and Barnes, 1958: 550), the initial propagule could have been only a single individual.



Figure 3. View of landing site at Bahía Covadonga, Isla San Ambrosio. The two wooden shacks are used by transient lobster fishermen. Photo by R. M. Gilmore.

THIS PAGE IS LOCKED TO FREE MEMBERS
Purchase full membership to immediately unlock this page

FORGOTTEN BOOKS

FULL MEMBERSHIP

797,885 Books!
All you can read
for only
\$8.99/month

Continue

*Fair usage policy applies



cirrus II lacking grapple-like spines; caudal appendages lacking; mandible with four teeth, basal comb, and spine-like inferior angle.

Type species.—*Jehlius gilmorei* new species.

Remarks.—*Jehlius* is unique in that the parietal plates are not always symmetrically disposed and that the pattern of fusion of the plates has not become fixed at least within the few specimens available for study (Fig. 4). Also, shell development is obviously transitional between six and four plates, and in the two specimens with only four plates there is no indication whatsoever that these plates will secondarily coalesce.

The shell of *Chamaesipho* is fundamentally composed of six plates, rostrum, carina, and paired rostrolaterals and laterals, but the genus is regarded as tetramerous (see Moore, 1944; Pope, 1965; Newman, Zullo and Withers, 1969). The six sutures separating these plates in *C. columna* are rarely seen in individuals beyond 2 mm in rostro-carinal diameter and occasionally they are obliterated in individuals as small as 0.5 mm in diameter (Moore, 1944: 317). In *C. brunnea*, on the other hand, the sutures delimiting the plates are no longer visible by the time individuals reach 6 mm in diameter (Moore, 1944).

In both species of *Chamaesipho* mentioned above, the rostrolaterals are united with the laterals. In specimen 1 of *Jehlius* (see Fig. 4), the arrangement of the wall plates appears to be the same as in *Chamaesipho columna*. In specimen 3, the right lateral is fused and secondarily coalesced in part with the carina, but the left lateral is fused with the rostrolateral. In specimen 2 the right lateral and rostrolateral are fused with the rostrum, and the left

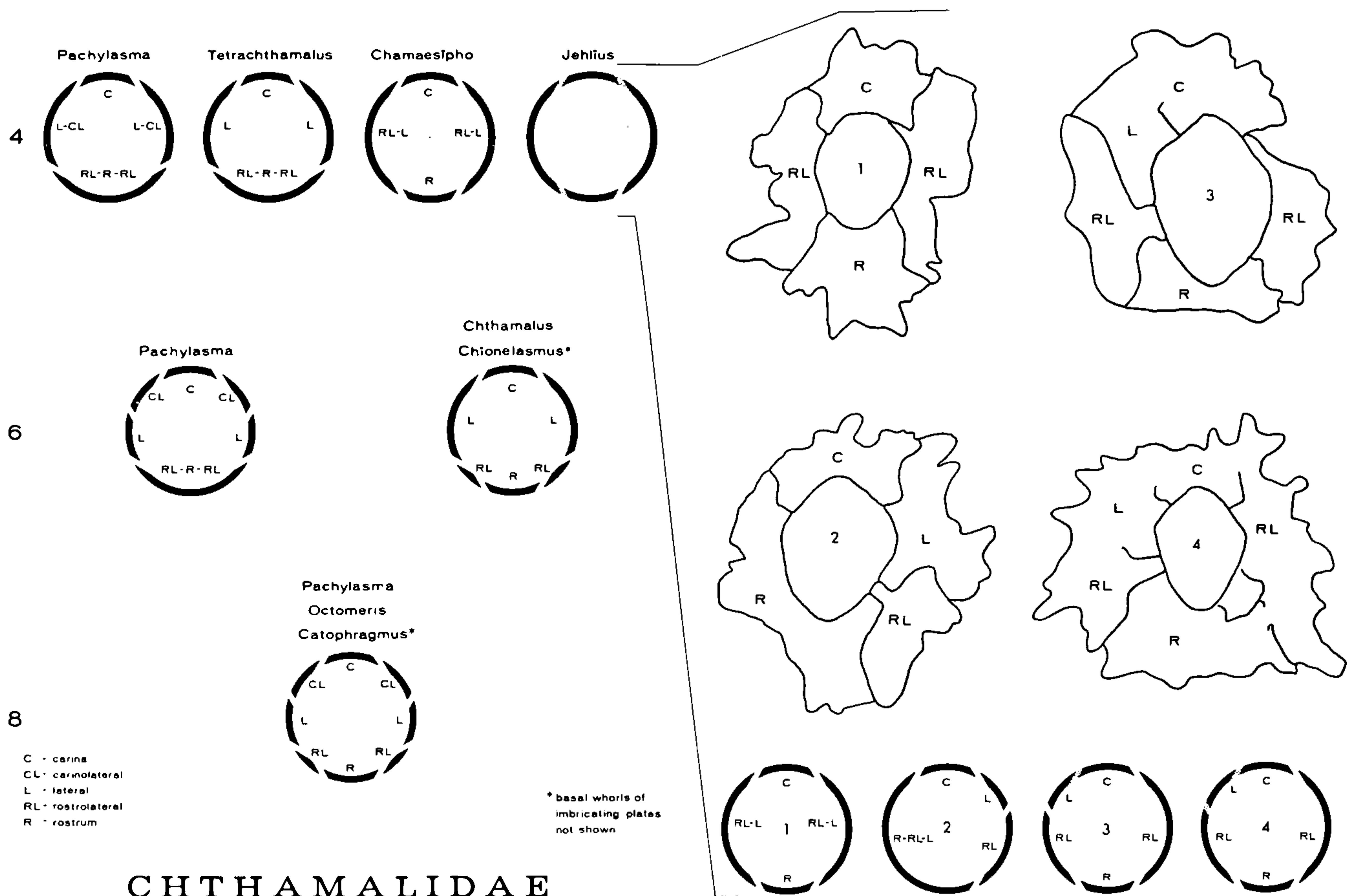

CHTHAMALIDAE

Figure 4. Plan views of wall construction in the Chthamalidae. Numerals at left indicate grades of decreasing complexity. Shell outlines of *Jehlius* on right side are camera lucida drawings of the internal surface showing degree of development of sutures, which are not readily discernible on external surface of shell (right side of shell is on left side in drawing). Number in center of orifice refers to number in plan view below. Specimen No. 3 is holotype, S.D.S.N.H. No. 4003/3.

rostromedial and lateral remain separate. Specimen 4 is the most unusual of the lot. It has one major suture, between the rostrum and the right rostromedial, and all of the other plates are partially coalesced (Fig. 5). Aside from the unusual arrangement of the wall plates there is nothing to suggest that the shells are pathologically malformed.

Jehlius also differs from *Chamaesipho* in the articulation of the opercular plates. The junction between the scutum and tergum on each side, when viewed internally, in *Chamaesipho* takes the form of the Greek letter omega, but in *Jehlius* it is simpler and only slightly sinuous. *Jehlius* also differs in that cirri I-III lack the grapple-like spines and the scutum lacks an adductor ridge but has a well defined deep pit for the insertion of the adductor muscle (Fig. 6).

Jehlius obviously is derived from an Eastern Pacific stock of *Chthamalus*, whereas *Chamaesipho* probably was derived from an Indo-Pacific stock. Furthermore, *Chamaesipho* is restricted to the austral region and the probability of penetrating the East Pacific barrier is remote.

Tetrachthamalus, also a genus with four plates that evolved from *Chthamalus*, differs from *Jehlius* in that the rostromedials are fused with the rostrum to form a tripartite plate, and during the ontogeny of individuals in this genus the four plates coalesce.

Etymology.—Named for Dr. Joseph R. Jehl, Jr., San Diego Museum of Natural History, longtime friend and colleague, and collector of the specimens reported on herein.

Jehlius gilmorei n. sp.

Diagnosis.—Crest of labrum armed with 50-60 simple conical teeth; cutting edge of maxilla II with 10-13 long spines in medial cluster; intermediate articles of posterior cirri, which have rami of equal length, bear 5 pairs of setae; basal segment of anterior ramus of cirrus I armed with stout spines.

Description.—Shell white or grayish-white, low conic, broadly ovate to subcircular in outline; basal portion of compartments ribbed and periphery of shell irregular or strongly toothed (Fig. 5); upper portion of external surface corroded, exfoliating; aperture relatively large owing to corrosion; radii lacking; sheath less than $\frac{1}{4}$ height of compartments, basal margin not depending; surface below sheath smooth. Basis membranous.

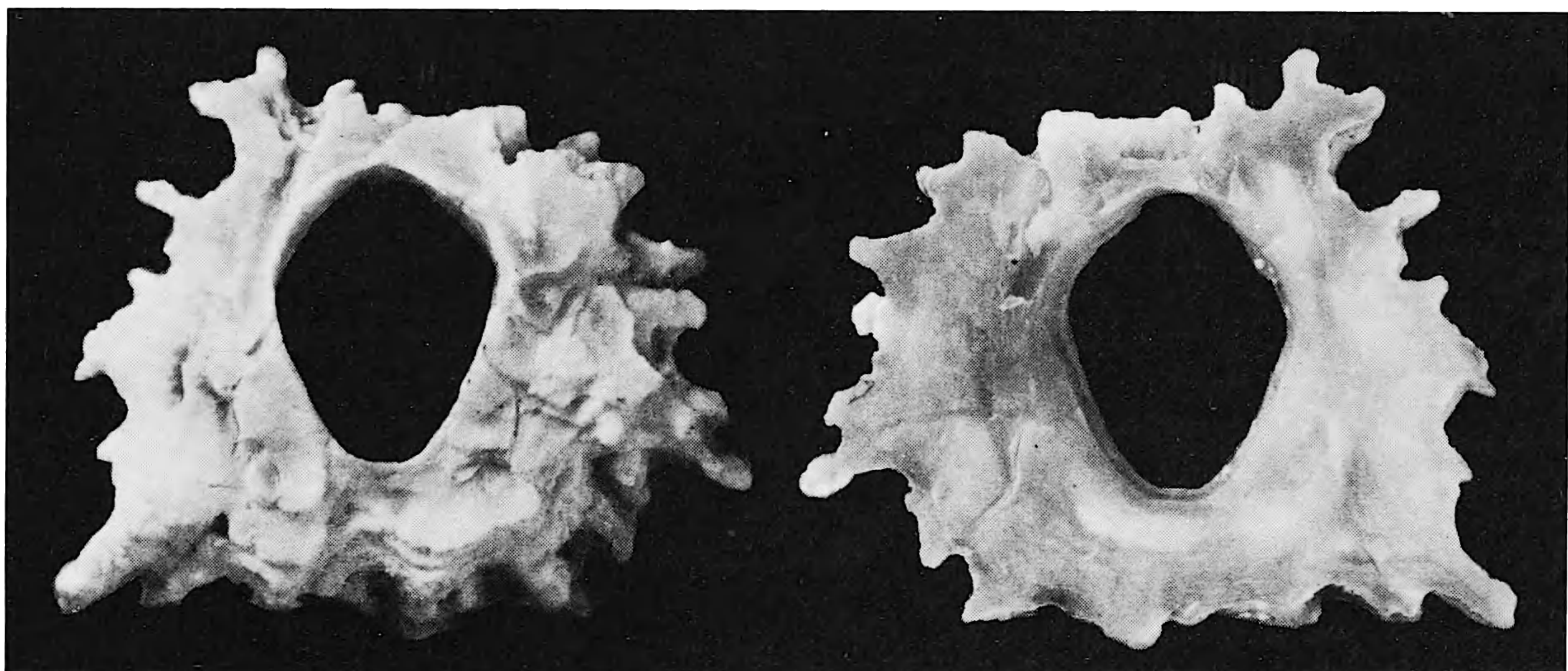

Figure 5. *Jehlius gilmorei* n. gen., n. sp. External and internal views, respectively, of shell. Paratype, S.D.S.N.H. No. 4004/4; actual rostro-carinal diameter, 8.1 mm.

Scutum transversely elongated (Fig. 6); length about $\frac{1}{3}$ greater than height; external surface poorly preserved, exfoliating; only last 3-4 newly formed growth ridges preserved along basal margin of plate; articular ridge poorly differentiated from articular surface; adductor ridge absent; depression for adductor muscle deep, well delimited; depression for lateral depressor muscle deep, well defined, crossed by 3-4 septa; depression for rostral depressor muscle commonly shallow, poorly delimited; apical portion of plate lacking ridges, crests, or pits.

Tergum higher than wide (Fig. 6); external surface poorly preserved, exfoliating; external longitudinal furrow apparently lacking; spur rounded or pointed distally, and not distinctly separated from articular margin; articular ridge low, poorly developed; parallel and immediately adjacent to articular ridge there is a row of shallow, oblong pits; there are 2 prominent and 1-2 lesser crests for the insertion of the lateral depressor muscle; apical portion of plate either slightly pitted or roughened.

Measurements of the holotype (in mm) are as follows: rostro-carinal diameter 9.7, lateral diameter 9.1, height 5.1, rostro-carinal diameter of orifice 5.2, height of scutum 3.0, width of scutum 3.9, height of tergum 2.8, width of tergum 2.0. The range in rostro-carinal diameter of the four specimens is 8.1-10.1 (\bar{x} = 9.2), and the range in height is 2.6-5.1 (\bar{x} = 3.3).

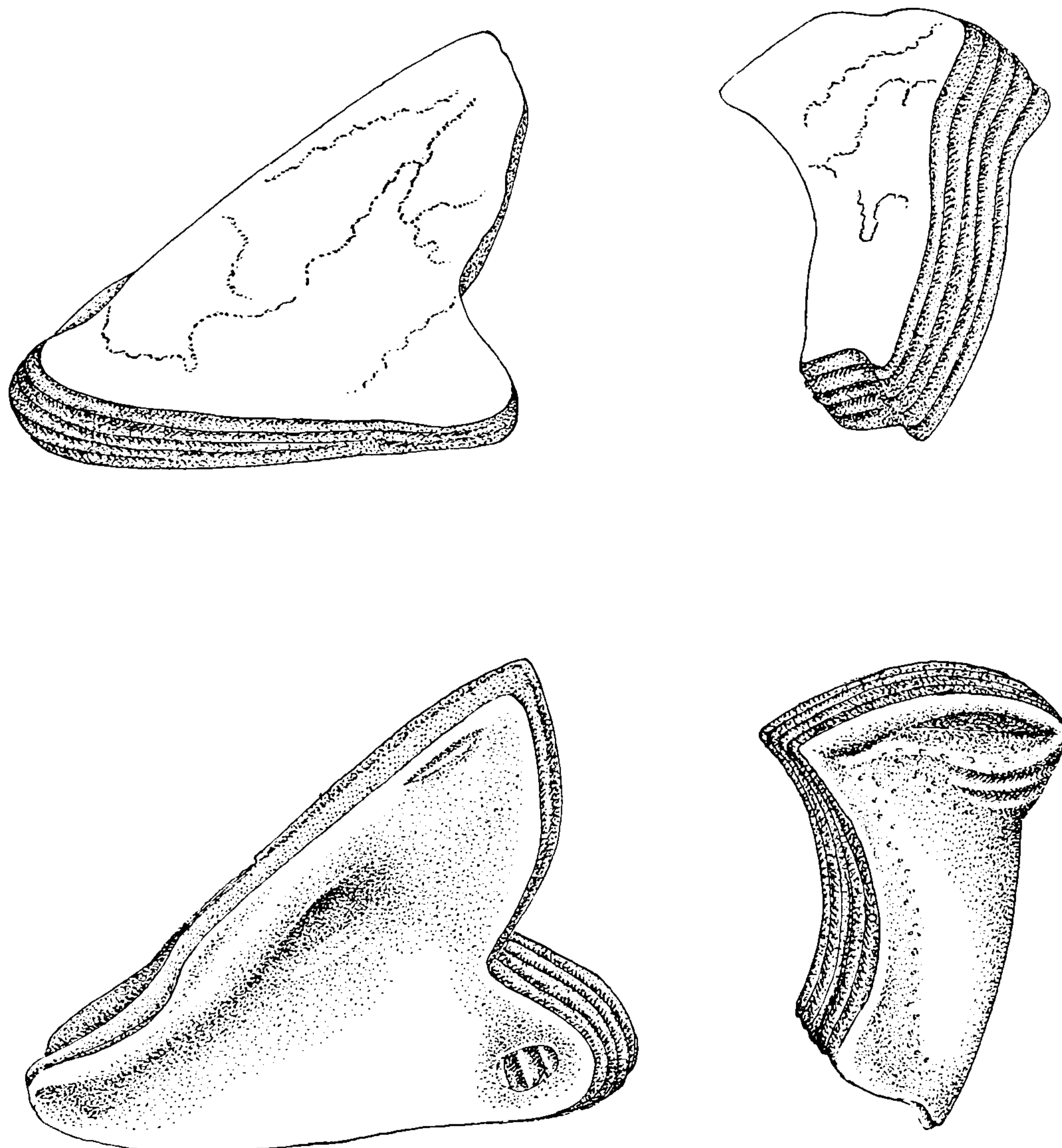

Figure 6. Opercular plates of *Jehlius gilmorei* n. gen., n. sp. External views of scutum and tergum, respectively (top row), and internal views of scutum and tergum, respectively (bottom row). Paratype, S.D.S.N.H. No. 4004/2. Drawings by Anthony D'Attilio.

THIS PAGE IS LOCKED TO FREE MEMBERS
Purchase full membership to immediately unlock this page

DELVE INTO FANTASY, MAGIC, MYTHOLOGY & FOLKLORE

Forgotten Books'
Full Membership gives
access to 797,885 ancient
and modern, fiction and
non-fiction books.

Continue

*Fair usage policy applies

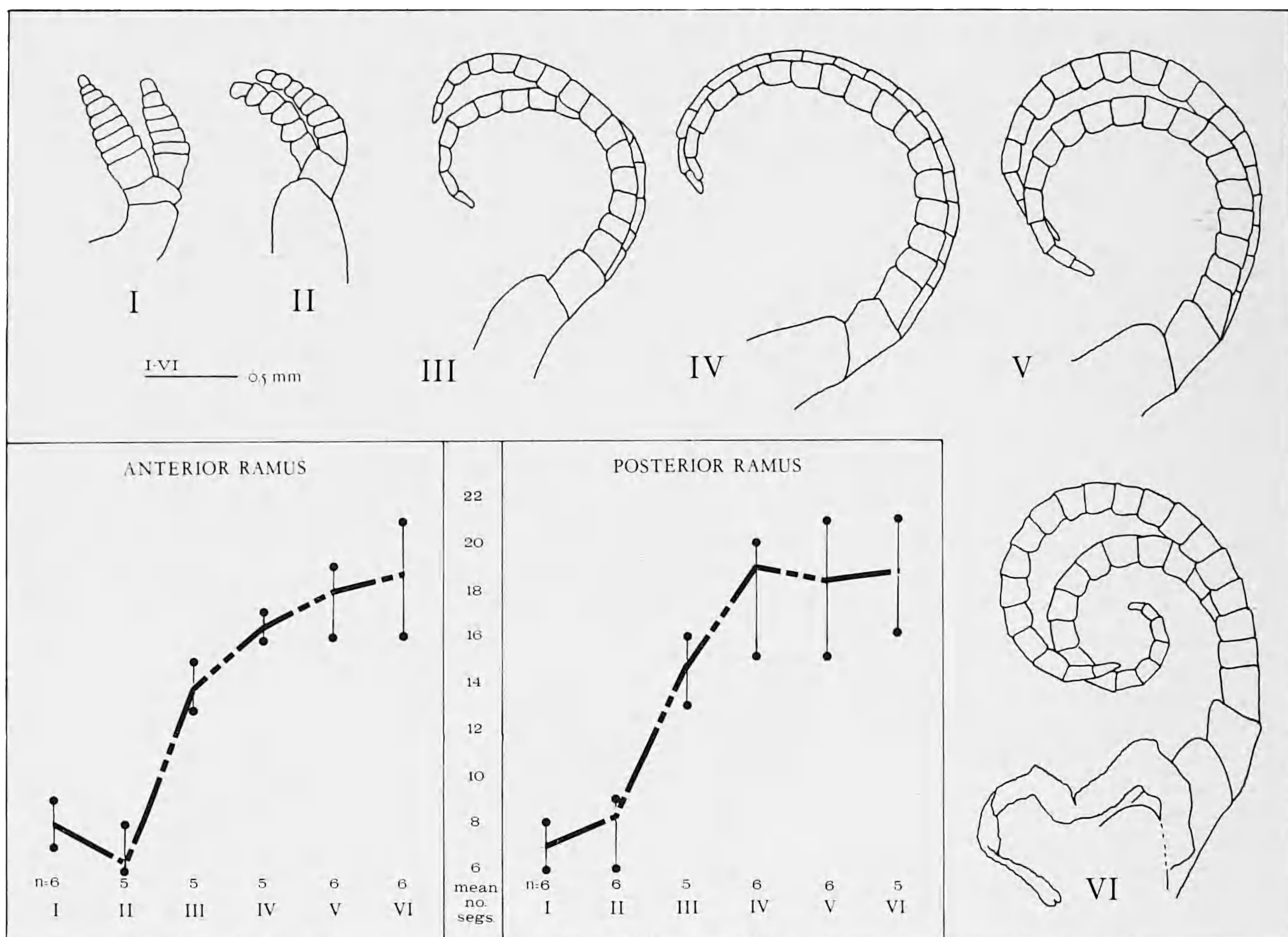

Figure 8. Outline drawings of cirri I-VI (setae omitted; paratype, S.D.S.N.H. No. 4004/2) and summary of data on cirral counts for the holotype and two paratypes.

vature of intermediate articles; 1 row of ctenae on lateral face of intermediate segments below articulation; setation ctenopod, with 5 pairs of setae on each intermediate segment; at base of each pair of setae there are 2-3 short, slender setae. Cirral counts for specimens in the type lot are summarized in Figure 8.

Intromittent organ annulated throughout its length, and sparsely covered with short, slender bristles; distal extremity bilobed and each lobe bearing about 15 or 16 short, slender setae.

Type Locality.—On northeast coast, just west of Bahia Covadonga, Isla San Ambrosio, Islas de los Desventurados, Chile, approximately $26^{\circ} 20' 15''$ S., $79^{\circ} 15' 45''$ W., I. M. W. SG 17; intertidal on volcanic rock; J. R. Jehl, Jr. coll., 27 June 1970; USARP cruise 70-3.

Disposition of types.—The holotype and three paratypes are housed in the collections of the San Diego Society of Natural History, Marine Invertebrate catalogue numbers 4003/3 and 4004/1, 4004/2 and 4004/4 respectively.

Etymology.—The specific epithet honors Dr. Raymond M. Gilmore, Research Associate, San Diego Natural History Museum, and chief scientist aboard the trawler *Hero* during USARP cruise 70-3.

INTRAFAMILIAL RELATIONSHIPS

Four families are presently recognized within the suborder Balanomorpha, namely

Chthamalidae, Bathylasmatidae, Tetracitidae, and Balanidae (see Newman and Ross, 1971: 137). Of these, the Chthamalidae are more generalized structurally and appear in the fossil record before any of the others.

Within the Balanomorpha the evolutionary history has been one of reduction in the number of compartments composing the shell (Pilsbry, 1916: 291; Withers, 1928: 46). In the Chthamalidae this reduction has been accompanied further by structural modification of the mouth parts and cirri for feeding (Zullo, 1963: 190).

Based on the probable mode of reduction in the number of shell elements, two lineages are evident in the Chthamalidae. In the first, consisting solely of *Pachylasma*, the shell initially contains 8 plates, including rostrum, carina, and paired rostromedials, laterals, and carinomedials. Subsequently, the rostromedials coalesce with the rostrum forming a tripartite plate, and the carinomedials may coalesce with the laterals yielding a shell of only 4 plates (Fig. 4).

The second lineage (*Octomeris-Chthamalus* group) includes the remaining genera (Fig. 4; see Newman and Ross, 1971: 141; cf. Utinomi, 1968: 36). Of these, *Catophragmus* (including the subgenera *Catomerus* and *Pachydiadema*) and *Octomeris* have the same number and arrangement of the plates as does *Pachylasma*. Early in the evolution of this lineage, the number of shell elements was reduced through elimination or exclusion since *Chthamalus* has only six wall plates (rostrum, carina, and paired rostromedials and laterals), the carino-laterals lacking. The small size of the carina and the presence of alae point to reduction by exclusion. From *Chthamalus* a further reduction in the number of wall plates, by fusion, is evident in *Tetrachthamalus* and *Chamaesipho*. In *Tetrachthamalus* the rostromedials are fused with the rostrum, as shown by the size of the composite plate and by the fact that it has radii, thus forming a tripartite plate essentially similar to that in *Pachylasma* and the bathylasmatid *Tessarelasma*. In *Chamaesipho columna* and *C. brunnea* the shell initially contains six plates; the rostromedials fuse with the laterals (Withers, 1928: 45; Moore, 1944: 324) rather than with the rostrum as in *Tetrachthamalus*. By the time individuals of *C. columna* reach a rostrocarinal diameter of 2 mm and individuals of *C. brunnea* a diameter of 5-6 mm, all the plates coalesce secondarily, and the sutures are obliterated. In adults of *Tetrachthamalus obliteratus*, which reach a rostrocarinal diameter probably not much greater than 6 mm, the sutures are commonly distinct; but then coalescence occurs, and remnants of these sutures can be observed in the sheath (Newman, 1967: 427).

In all chthamalids with 6 or 4 plates fusion of shell elements and their subsequent coalescence proceeds in a uniform manner. To judge from the specimens available, this apparently is just the opposite of what takes place in *Jehlius* (Fig. 4). Although two specimens of *Jehlius* have in part attained a grade of construction comparable with that found in 4-plated individuals of *Chamaesipho*, two specimens are effectively intermediate between six and four plates. In the two specimens that have attained a 4-plated grade of construction, there is no secondary coalescence and obliteration of the sutures uniting these wall plates.

In his classification of the chthamalids Zullo (1963:190) stressed the modification in mandibular and cirral structures attending the reduction in number of the wall plates. In *Octomeris*, *Chthamalus*, *Chamaesipho*, *Tetrachthamalus* and *Jehlius* the mandible is characteristically quadridentoid, but in *Catophragmus*, *Catomerus*, *Chionelasmus*, *Euraphia* and *Pachylasma* it is tridentoid. In the *Octomeris-Chthamalus* lineage the third cirrus is relatively unmodified; but in the *Pachylasma* lineage, feeding adaptations involve the modification of cirrus III as a mouth appendage, such as is found in the balanids.

Pachydiadema from the Cretaceous (U. Senon.) of Sweden is the oldest known

chthamalid with eight wall plates and at least two whorls of imbricating basal plates. The number and arrangement of wall plates, simple opercular valves, caudal appendages, and unmodified third cirrus all tend to link *Pachydiadema* with the scalpellid lepadomorphs (Newman, Zullo, and Withers, 1969: R 269).

Pachydiadema is probably ancestral to *Catomerus* (Withers, 1935: 390; Pope, 1965: 15), which also possesses eight wall plates and several whorls of imbricating plates. *Catophragmus* also may have been derived from *Pachydiadema*, or possibly from *Catomerus*. The presence of caudal appendages in *Catophragmus* suggests derivation from *Pachydiadema* rather than from *Catomerus* which lacks these appendages. *Chionelasmus* with but six wall plates (carinolaterals lacking) and a single whorl of basal plates, and with caudal appendages, is probably an off-shoot from *Catophragmus*.

Octomeris lacks the basal whorls of plates and caudal appendages, and hence is probably derived from *Catomerus*, which also lacks caudal appendages, and the articulation of the opercular plates is simple rather than complex as it is in *Catophragmus*. From *Octomeris* it is a single step, through loss of the carinolaterals, to *Chthamalus* and *Euraphia*, which probably share a common ancestry. However, *Euraphia* has retained the lepadomorph or early chthamalid tridentoid mandible whereas *Chthamalus* has evolved the quadridentoid mandible with a basal comb.

Chamaesipho evolved from *Chthamalus* (Newman, 1967: 431), and probably rather recently. Although young individuals of *Chamaesipho brunnea* and *C. columna* develop rostralateral plates initially, these soon fuse with the laterals forming a shell with only four plates; later the sutures coalesce, and are obliterated. In *Euraphia* the plates apparently never coalesce but they do develop an inflected basal rim (see Newman, 1961). *Tetrachthamalus* is also an offshoot from *Chthamalus* (Newman, 1967: 431) but apparently of greater antiquity than *Chamaesipho*. In *Tetrachthamalus* there is no evidence in the ontogeny of a stage having six plates as in *Chamaesipho*, but as in *Chamaesipho* the plates eventually coalesce. The wall plates in *Tetrachthamalus*, unlike those in *Chamaesipho* and *Jehlius*, develop an inflected basal rim. *Jehlius* is apparently the most recent offshoot from *Chthamalus*, and is most closely related to *C. cirratus*.

ACKNOWLEDGMENTS

For the loan or gift of comparative materials I thank Elizabeth Pope, The Australian Museum, Brian Foster, University of Auckland, William A. Newman, Scripps Institution of Oceanography (S.I.O.), and Meredith L. Jones, Smithsonian Institution. I thank my personal physician Dr. Wayne L. Heath and his assistant Mrs. Susan D. Dobbin for providing me with x-rays of the specimens. Mrs. Marguerette Schultz, S.I.O., brought to my attention the recent studies by K. Wyrski, and my wife Cecelia, S.I.O., helped me locate bathythermograph data from the ships *Yelcho*, *Anton Brunn* and *Esmeralda*. For criticisms and comments on manuscript copy, or other courtesies, I thank W. A. Newman, S.I.O., Joseph R. Jehl, Jr., Raymond M. Gilmore, Reid Moran, and Dwight W. Taylor, San Diego Natural History Museum.

LITERATURE CITED

- Allen, J. A.
1899. Fur-seal hunting in the southern hemisphere, p. 307-319. In, Jordan, D. S., et al., The Fur seals and fur seal islands of the north Pacific Ocean. Part III. Special papers relating to the fur seal and to the natural history of the Pribilof Islands. Washington, Gov't. Print. Off.
- Bahomonde N., N.
1966. Islas Desventuradas. Mus. Nac. Hist. Nat. Chile, ser. Educ. 6: 1-15.
- Barnes, H., and M. Barnes
1958. Further observations on self-fertilization in *Chthamalus* sp. Ecology 39(3): 550.
- Crisp, D. J., and A. J. Southward
1953. Isolation of intertidal animals by sea barriers. Nature 172(4370): 208-209.
- Douglas, G.
1970. Draft check list of Pacific oceanic islands (foreward by E. M. Nicholson). Micronesia 5(2): 327-463.

THIS PAGE IS LOCKED TO FREE MEMBERS
Purchase full membership to immediately unlock this page

FORGOTTEN BOOKS

FULL MEMBERSHIP

797,885 Books!
All you can read
for only
\$8.99/month

Continue

*Fair usage policy applies



1968. Circulation and water masses in the eastern Equatorial Pacific Ocean. *Intl. J. Oceanol. Limnol.* 1(2): 117-147.

Zullo, V. A.

1963. A classification and phylogeny of the Chthamalidae (Cirripedia: Thoracica). *Proc. 16th Internatl. Congr. Zool., Washington*, 1: 190.

*Department of Invertebrate Paleontology, Natural History Museum, P. O. Box 1390,
San Diego, California 92112*

**THE LARVAL AND PUPAL STAGES OF FOUR SPECIES OF
CAFIUS (COLEOPTERA: STAPHYLINIDAE) WITH NOTES
ON THEIR BIOLOGY AND ECOLOGY**

GARY J. JAMES, IAN MOORE AND E.F. LEGNER

TRANSACTIONS

**OF THE SAN DIEGO
SOCIETY OF
NATURAL HISTORY**

VOL. 16, NO. 12

5 NOVEMBER 1971

THIS PAGE IS LOCKED TO FREE MEMBERS
Purchase full membership to immediately unlock this page

DELVE INTO FANTASY, MAGIC, MYTHOLOGY & FOLKLORE

Forgotten Books'
Full Membership gives
access to 797,885 ancient
and modern, fiction and
non-fiction books.

Continue

*Fair usage policy applies

in a plastic container ranged from 45 to 72 hours.

We observed one individual of *Cafius lithocharinus* which had the longest survival in sea water, and found that it supported itself on its tibia on the water surface film for about 2½ hours. This individual, when placed in a plastic enclosed container partly filled with sea water, flew three times but finally resorted to merely floating on the surface as was characteristic of the other three species studied. When pushed beneath the water, all four species curled their abdomens up and back toward the thorax. The crook thus formed entrapped a bubble of air, which was carried beneath the surface. Upon release the beetle floated back to the surface and extended its abdomen, then groomed the head and antennae with the forelegs. Flotation ceased when the beetle dropped its abdomen below the water surface, curved the abdominal tip back towards the head, and ceased leg movement. The body then sank to the bottom and movement stopped.

Sea water thrown on beached seaweed caused beetles to come to the surface and fly away. A thorough soaking of the deposit drove out all beetles. Beetle flight was always away from the ocean, either up the beach or parallel to the surf, the ultimate goal being undisturbed piles of seaweed nearby.

Fresh piles of seaweed were colonized by large numbers of adult staphylinids within two weeks of deposition. Once 800 individuals of *Cafius lithocharinus* were captured, marked with white paint, and released on the beach near their capture. None of the marked individuals was ever recovered.

Predation.—*Cafius canescens* and *C. seminitens* were voracious predators of both larvae and pupae of *Fucellia*, while *C. lithocharinus* and *C. luteipennis* were only casual feeders on larvae under experimental conditions (James, 1968). The adults of the four common species are chiefly predatory, although some were seen to scavenge on dead grunion. Other known prey of *Cafius* includes amphipods and small barnacles; at times they also preyed on their own larvae and pupae as well as those of related species.

Feeding Behavior.—*Cafius seminitens* and *C. canescens* upon encountering a fly larva would grasp it with the mandibles, and break the larval intergument. Oozing body fluids attracted other staphylinids, which joined in the consumption of the prey. We observed *C. canescens* breaking the surface layers of seaweed with its mandibles to feed on fly larvae within. This action attracted additional staphylinids which then shared the kill. On one occasion seven beetles consumed a fly larva in nine minutes. *Cafius seminitens* and *C. canescens* were capable of excavating a hole in the puparium of a fly larva, and consuming the oozing fluids. Pupae were rarely shared.

Mating Behavior.—Although end-to-end mating postures were observed, usually the male assumed a superior position. The males use their mandibles to grip the females on the 2nd and 3rd abdominal segments below the elytra, in addition to using their legs to hold the female in position. In *C. canescens* the male extended the aedeagus while curling his abdomen around and downward to meet the female's upcurved abdomen. This position was retained for as long as 77 seconds.

Immature Stages.—In the laboratory, individually placed eggs of *Cafius canescens* were deposited about 1 inch below the sand surface. Gestation was about 6 days at room temperature. A newly hatched larva immediately excavated a burrow about 5 inches deep in a sand-filled test tube. Pieces of cockroaches which were dropped into the test tube were examined by the staphylinid larva on the surface and finally pulled into the sand burrow.

The larva oriented itself with its head toward the sand surface. The burrow was enlarged and extensions were made in succeeding larval stages. Pupation occurred about 27 days after egg laying at the 1/2 inch level in sand. Adult eclosion occurred on the 39th

day after the egg was laid.

Larvae of *C. canescens* were first collected from the beach at Coronado on 15 March 1967. Overwintering apparently occurs in either the egg, pupal or adult stage. After 1 April, *C. canescens* larvae were collected regularly in small numbers at all study sites. *Cafius luteipennis* larvae were placed in a cage on 25 March and pupated 31 days later. After 4 May, larvae of *C. luteipennis* were collected in small numbers from the Coronado site. On 8 July, larvae of *C. lithocharinus* were first collected at Coronado, and the pupae were formed 34 days after a second set of larvae was collected on 27 August.

The large larvae of *Cafius seminitens* were first observed at Corona Del Mar on 18 September. Pupation occurred 18 days later and adults emerged on the 28th day. Only *Cafius seminitens* larvae were seen to feed on seaweed fly larvae, devouring their prey in a similar manner as the adults.

The various species of *Cafius* apparently breed at different times of the year, as indicated by their appearance at different dates. *Cafius canescens* and *C. luteipennis* appear to breed in early spring, *C. lithocharinus* in early summer, and *C. seminitens* in late summer.

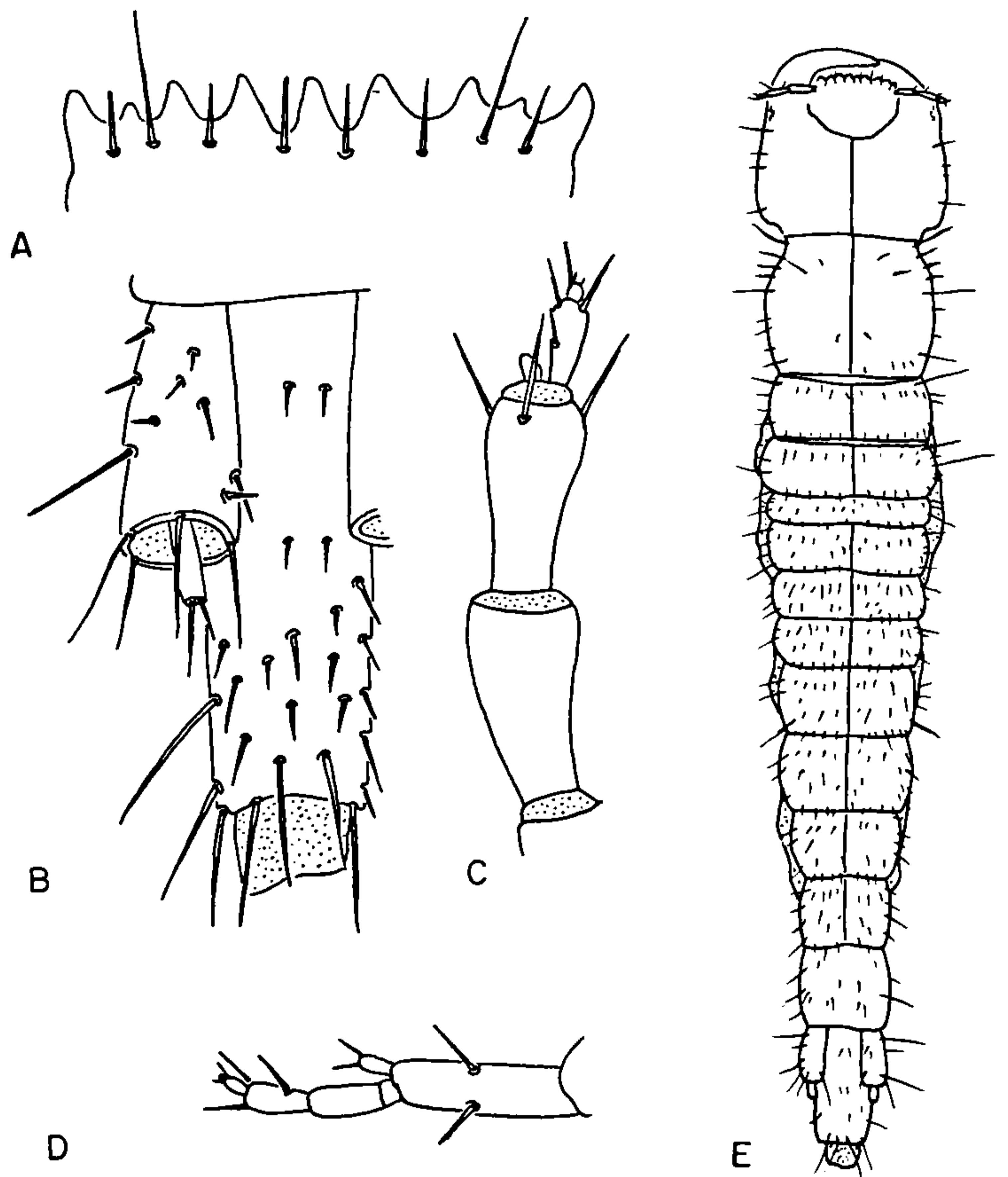

Figure 1. Larva of *Cafius canescens* Mäklin. a, anterior margin of clypeus; b, urogomphus and pseudopodia; c, antenna; d, maxilla; e, dorsal view of body.

DESCRIPTIONS OF EARLY STAGES

LARVAE

The larva of the European *Cafius sericeus* Holme was described by Rey (1887) and that of *C. xantholoma* (Gravenhorst) by Rupertsberger (1880). Paulian (1941) redescribed both of these species, using the name *Remus sericeus* for the former. *Remus* generally is considered a subgenus of *Cafius*. Paulian gave no generic description for the larva of *Cafius*. But a combination of characters from his key makes a good diagnosis of this genus. It follows:

Cephalization accentuated; neck present; epicranial suture very long; gular sutures very long; ocelli four, arranged in a compact group near bases of antennae; nasal present; max-

illary palpus four-segmented; galea present, movable, with the aspect of a segment; lacina reduced at maximum to some local spines in the apical region of the stipes; prosternum strongly chitinized.

The combination of these diagnostic characters and the seashore habitat, permit easy recognition of *Cafius* larvae.

In his key Paulian used other characters which new material shows to be too variable for a generic definition. Thus the middle teeth of the nasal do not differ from the lateral teeth in all the Pacific Coast species. And although the urogomphus is two-segmented and longer than the pseudopod in two of our species, in the other two it is shorter than the pseudopod. In one of the latter the urogomphus is distinctly one-segmented and spherical.

KEY TO THE KNOWN LARVAE OF *CAFIUS*

- 1A. Urogomphus longer than pseudopod.
 2A. Second segment of urogomphus widest at base, tapered to apex.
 3A. Composite macrosetae much more numerous than simple macrosetae. *sericeus*
 3B. Simple macrosetae much more numerous than composite
 macrosetae *xantholoma*
 2B. Second segment of urogomphus long, slender, cylindrical.
 4A. First segment of maxillary palpus one-half as long as second
 segment. *luteipennis*
 4B. First segment of maxillary palpus about as long as second
 segment. *lithocharinus*
 1B. Urogomphus shorter than pseudopod.
 5A. Urogomphus two-segmented, the segments subcylindrical *canescens*
 5A. Urogomphus one-segmented, spherical *seminitens*

LARVA OF *CAFIUS LUTEIPENNIS* HORN

Color.—Pale, with head dark testaceous.

Head subquadrate, widest near basal angles, slightly narrowed to apical angles. Neck about three-fourths as wide as head. Ocelli four, in a small cluster near apical angles. Clypeal margin with nine teeth, the two outer teeth on each side smallest, the next two on each side longer than wide, the central tooth little more than half as long as those next to it (Fig. 3A). Antennae four-segmented, the first segment short, the second and third about as wide as first and each about twice as long as wide, the third with a small ovoid seta at apex, the fourth about half as wide and half as long as third with a very small, round modified seta at apex (Fig. 3C). Maxilla (Fig. 3D) with the stipes almost as long as palpus; galea small elongate-ovoid; maxillary palpus four-segmented, the first segment about as long as wide, the second as wide as and twice as long as first, the third somewhat narrower and shorter than second, the fourth small, elongate-ovoid. Ligula about as long as first segment of labial palpus, pubescent basally. Labial palpus three-segmented, the first segment about twice as long as wide, the second a little narrower and shorter than first, the third much narrower and shorter than second. Gular sutures united in basal three-fifths, thence divergent to apex.

Thorax.—Pronotum a little wider than long, widest near basal angles, narrowed slightly to apical angles, with a few scattered setae at sides and on disc. Mesonotum and metanotum shorter and a little wider than pronotum, with sparse scattered setae.

Abdomen with parallel sides in basal half, thence slightly narrowed to apex, the

THIS PAGE IS LOCKED TO FREE MEMBERS
Purchase full membership to immediately unlock this page

FORGOTTEN BOOKS

FULL

MEMBERSHIP

797,885 Books!

All you can read

for only

\$8.99/month

Continue

*Fair usage policy applies



riorly. Mesonotum and metanotum much shorter and slightly wider than pronotum.

Abdomen gently tapered from base to apex, the first segment short, the others progressively slightly longer, with scattered sparse setae throughout. Pseudopod nearly three times as long as wide. Urogomphus longer than pseudopod, two-segmented, the first segment almost as long as pseudopod, the second long and very slender (Fig. 4B).

Length.—8-11 mm.

Material examined.—Ten specimens: Hotel Del Coronado Beach, Coronado, San Diego Co., California, August 7, 1967, Gary James coll.

Notes.—This larva most closely resembles that of *C. luteipennis*, from which it may be distinguished by the relatively longer first segment of the maxillary palpus and by shorter clypeal teeth.

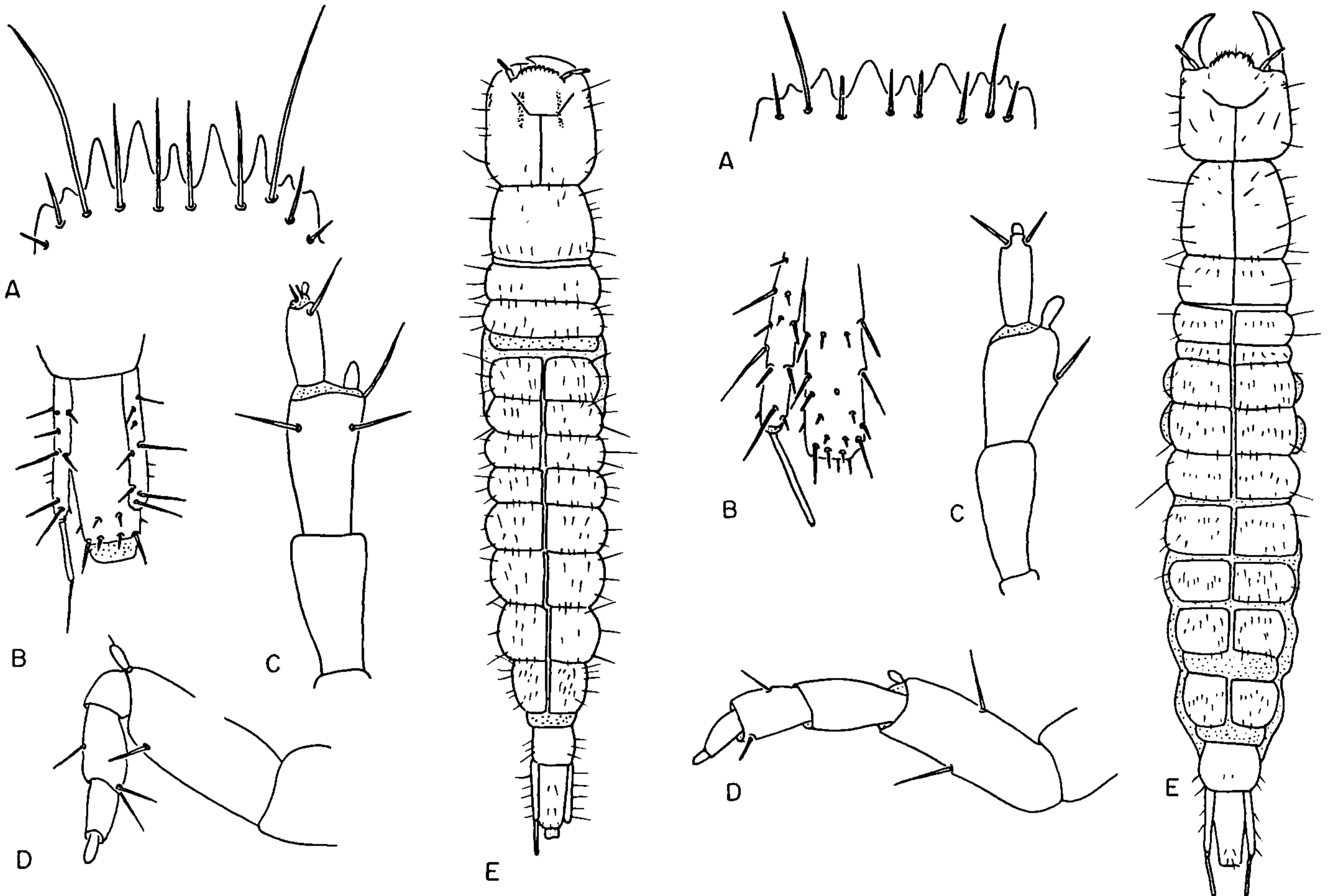

Figure 3. Larva of *Cafius luteipennis* Horn. a, anterior margin of clypeus; b, urogomphus and pseudopodia; c, antenna; d, maxilla; e, dorsal view of body.

Figure 4. Larva of *Cafius lithocharinus* LeConte. a, anterior margin of clypeus; b, urogomphus and pseudopodia; c, antenna; d, maxilla; e, dorsal view of body.

LARVA OF *CAFIUS CANESCENS* MÄKLIN

Color.—Pale testaceous, with head ferruginous. Ocelli and base and apex of mandibles dark.

Head subquadrate, widest just before the rounded basal angles, gradually narrowed to near the ocelli. Neck about five-sevenths as wide as head. Ocelli four, in a close cluster near the anterior angles. Frontal suture joining epicranial suture at an obtuse angle at about the anterior third of the head. Clypeal margin with nine similar teeth, the penultimate outer tooth on each side somewhat shorter than the others (Fig. 1A). Antenna with first segment widest, about as long as wide, the second segment about twice as long as first, the third

about as long as second and with a small modified segment at apex, fourth segment much narrower and shorter than third (Fig. 1C). Maxilla (Fig. 1D) with stipes almost as long as palpus, about twice as long as wide. Galea small, ovoid; maxillary palpus with first two segments subequal, the third much shorter and narrower than second, the fourth minute. Ligula about as long as first segment of labial palpus, pubescent in basal half. Labial palpus three-segmented, the first segment about twice as long as wide, the second a little shorter and distinctly narrower than first, the third narrower than second, very little longer than wide. Gular sutures united in basal three-fifths, thence divergent to apex.

Thorax.—Pronotum subquadrate, a little wider than long, widest near middle, thence narrowed slightly to base and to apex. Mesonotum and metanotum much shorter than and about as wide as pronotum. Each segment with a row of setae at anterior, lateral and posterior margins and a very few scattered setae on disc.

Abdomen widest at base, slightly tapered to apex; first segment shortest, the segments increasing in length progressively to apex; a little more densely setose than thorax. Pseudopod about twice as long as wide. Urogomphus two-segmented, shorter than pseudopod, subcylindrical (Fig. 1B).

Length.—9 mm.

Material examined.—Five specimens, ½ mile west of pier, San Clemente, Orange Co., California, 12 April 1967, Gary James coll.

Notes.—This larva differs from the other larvae of *Cafius* in having a two-segmented urogomphus that is much shorter than the pseudopod.

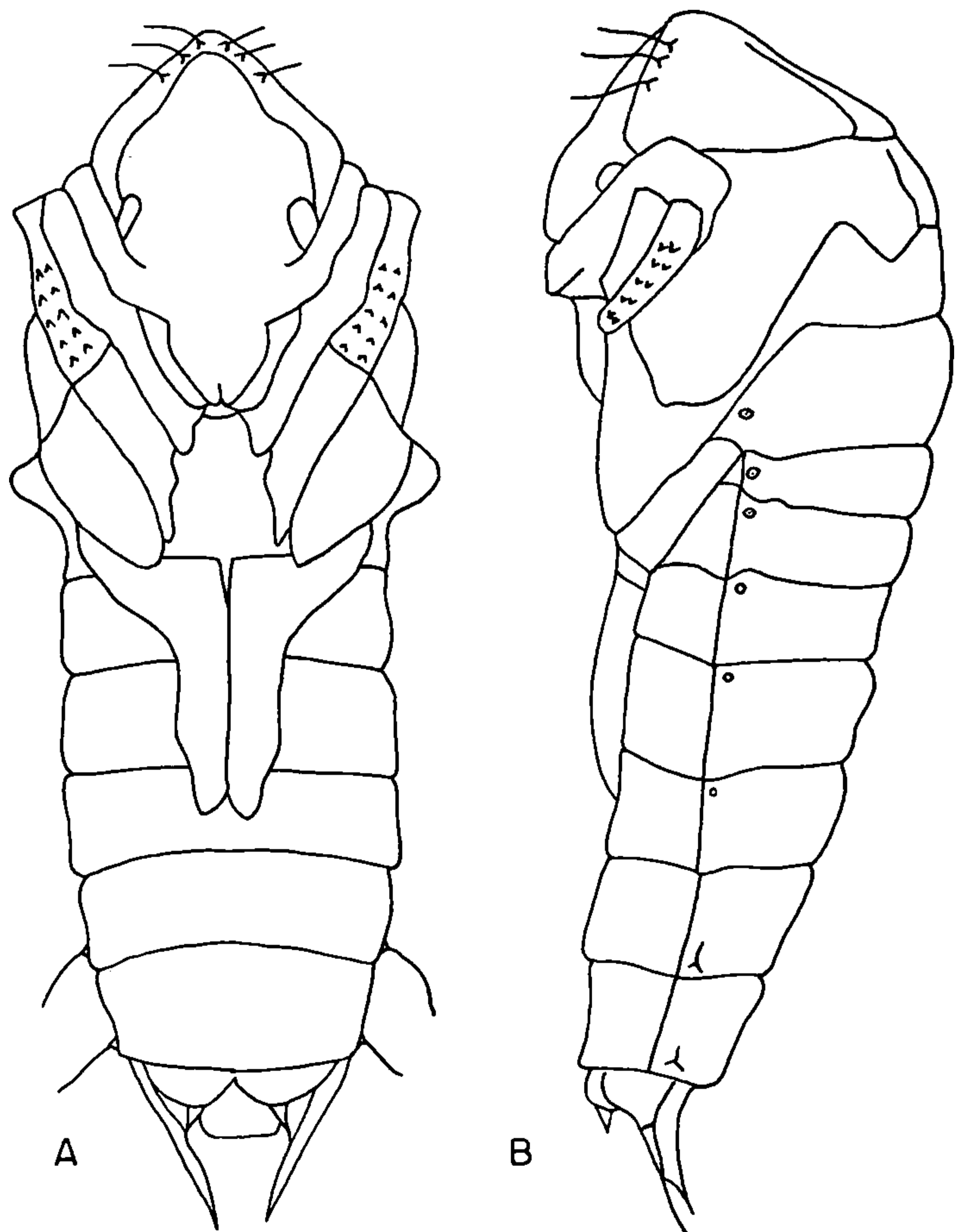

Figure 5. Pupa of *Cafius canescens* Mäklin. a, ventral view; b, lateral view.

LARVA OF *CAFIUS SEMINITENS* HORN

Color.—Pale testaceous, with head and pronotum ferruginous, the base and apex of mandibles darker. Head subquadrate, a little wider than long, widest near basal third,

thence slightly narrowed to apex. Neck about three-fourths as wide as head. Ocelli very pale, difficult to detect. Frontal sutures joining epicranial suture at an obtuse angle at about the apical third of head. Clypeal margin with nine teeth, the central tooth distinctly smaller than the others (Fig. 2A). Antenna four-segmented, the first segment short, the second and third as wide as and more than twice as long as first, the third with a rounded modified seta at apex, the fourth small ovoid (Fig. 2C). Maxilla with stipes as long as palpus, about twice as long as wide; galea small, oval; maxillary palpus (Fig. 2D) with a separate sclerotization forming a very short ring at base in the form of an extra segment which may represent the lacina; first segment of palpus about twice as long as wide, the second nearly as wide and as long as first, the third a little narrower and shorter than second, the fourth small, ovoid. Ligula about as long as first segment of labial palpus, pubescent at base. Labial palpus three-segmented, the first segment about twice as long as wide, the second narrower and a little shorter than first, the third much narrower and shorter than second. Gular sutures united in basal three-fifths, thence divergent to apex.

Thorax.—Pronotum transverse, the sides well rounded, widest at basal third, with a few scattered setae on disc and at sides. Mesonotum and metanotum narrower and shorter than pronotum, with a row of setae at base, sides and apex.

Abdomen slightly tapered from base to apex, the first few segments short, the apical segments progressively narrower and longer. First four segments irregularly, and densely set with short stout peg-like setae, the next five segments progressively more sparsely setose. Pseudopod about twice as long as wide. Urogomphus one-segmented, spherical, much shorter than pseudopod (Fig. 2B).

Length.—10-14 mm.

Material examined.—Five specimens, Corona Del Mar, Orange Co., California, 16 September 1967, Gary James collector.

Note.—This larva differs in several respects from other known larvae of *Cafius*, but par-

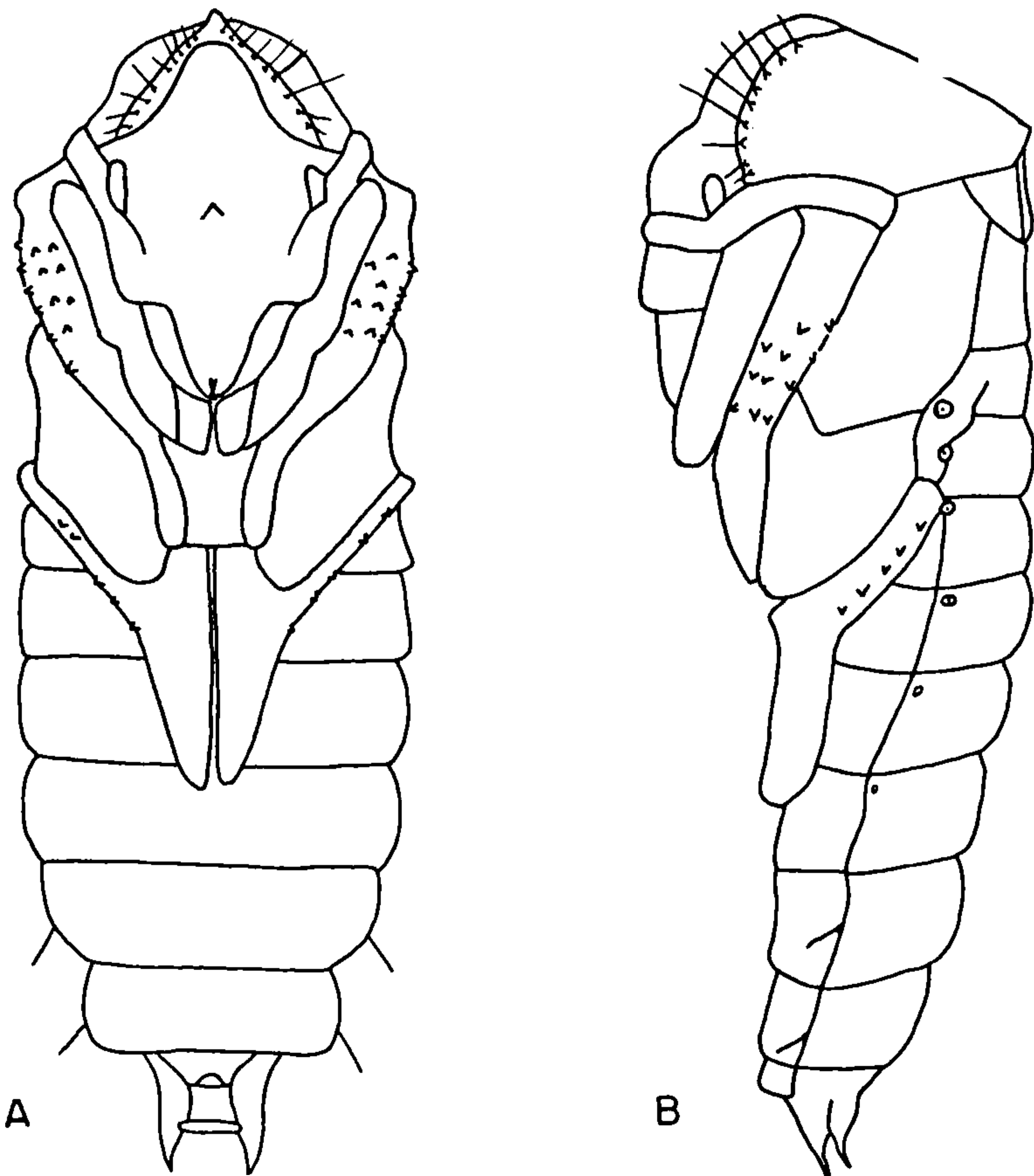

Figure 6. Pupa of *Cafius seminitens* Horn. a, ventral view; b, lateral view.

THIS PAGE IS LOCKED TO FREE MEMBERS
Purchase full membership to immediately unlock this page

DELVE INTO FANTASY, MAGIC, MYTHOLOGY & FOLKLORE

Forgotten Books'
Full Membership gives
access to 797,885 ancient
and modern, fiction and
non-fiction books.

Continue

*Fair usage policy applies

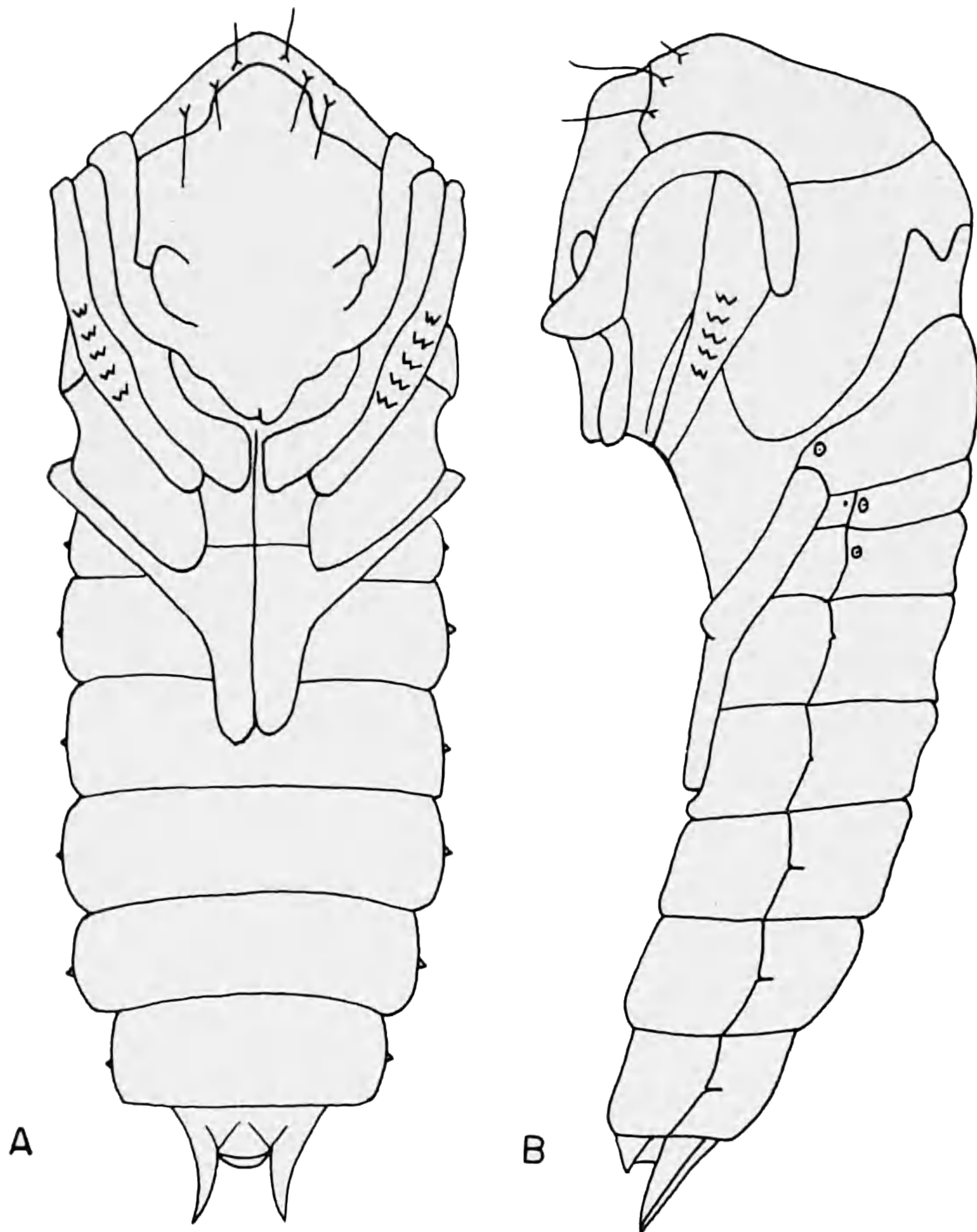

Figure 8. Pupa of *Cafius lithocharinus* LeConte. a, ventral view; b, lateral view.

KEY TO THE KNOWN PUPAE OF THE AMERICAN SPECIES OF *CAFIUS*

- 1A. Anterior margin of pronotum with a single row of nine setigerous tubercles each side *seminitens*
 1B. Anterior margin of pronotum with a single row of fewer than nine setigerous tubercles each side.
 2A. Anterior margin of pronotum with a single row of three setigerous tubercles each side *canescens, lithocharinus*
 2B. Anterior margin of pronotum with a single row of four setigerous tubercles each side *luteipennis*

Characters have not been found for the separation of the pupae of *C. canescens* and *lithocharinus*.

ACKNOWLEDGMENTS

We are indebted to Dr. Lauren B. Anderson, Mrs. Patricia Farrell and Mrs. Arlene Sansevero of the University of California at Riverside and to Fred G. Andrews of the California Department of Agriculture at Sacramento for aid in locating literature.

LITERATURE CITED

- Dawson, E. Y.
 1945. An annotated list of the marine algae and marine grasses of San Diego County, California. Occas. Papers San Diego Soc. Nat. Hist. 7:1-87.
 Dawson, E. Y.
 1966. Marine botany: An introduction. Holt Rinehart and Winston, Inc., N.Y. 371 p.
 James, G. J.
 1968. The biology and ecology of four species of the genus *Cafius* (Coleoptera: Staphylinidae). M.S. Thesis, San Diego State College. 72 p.

Moore, I.

1956. Notes on intertidal Coleoptera with descriptions of the early stages (Carabidae, Staphylinidae, Malachiidae). Trans. San Diego Soc. Nat. Hist. 12: 207-230.

Paulian, R.

1941. Les Premier états des Staphylinoidea. Etude de morphologie comparée. Mém. Mus. Hist. Nat. Paris, n. ser., 15: 1-361.

Rey, C.

1887. Essai d'études sur les larves des coléoptères. Ann. Soc. Linn. Lyon 33: 146-1480.

Rozen, J. G., Jr.

1958. Systematic study of the pupae of the Oedemeridae (Coleoptera). Ann. Ent. Soc. Amer. 52: 299-303.

- 1963a. Preliminary systematic study of the pupae of the Nitidulidae (Coleoptera). Amer. Mus. Novitates 2124: 1-13.

- 1963b. Two pupae of the primitive suborder Archostemata (Coleoptera). Proc. Ent. Soc. Washington 65: 307-310.

Rupertsberger, M.

1880. Biologie der Käfer Europas. Eine Übersicht der biologischen Literatur. Donau, Linz. 295 p.

Orange Coast College, Costa Mesa, California 92626 (G.J.J.), and Division of Biological Control, Department of Entomology, University of California, Riverside, California 92502 (I.M. and E.F.L.)

THIS PAGE IS LOCKED TO FREE MEMBERS
Purchase full membership to immediately unlock this page

FORGOTTEN BOOKS

FULL MEMBERSHIP

797,885 Books!
All you can read
for only
\$8.99/month

Continue

*Fair usage policy applies



THE COLOR PATTERNS OF DOWNY YOUNG RATITES AND TINAMOUS

JOSEPH R. JEHL, JR.

ABSTRACT.—Plumage patterns of downy young ratites indicate that the Casuariidae and Dromiceidae are closely related, and they suggest that the Struthioniformes and Casuariiformes may be more closely related to each other than either is to any other living ratite taxon. Relationships of the Rheiformes and Apterygiformes are not clarified. The Tinamidae fall into two distinct groups of genera: 1) *Tinamus*, *Nothocercus*, and *Crypturellus*, and 2) *Rhynchotus*, *Nothura*, *Nothoprocta*, and *Tinamotis*; chicks of *Taoniscus* were not examined. Chick plumages provide no evidence for close relationship between tinamous and any ratite taxon.

The ratites are large, flightless, running birds with an unkeeled sternum which, with one minor exception, are now restricted to the southern hemisphere. They include the extant families Struthionidae, Rheidae, Casuariidae, Dromiceidae, and Apterygidae, and the extinct Opisthodactylidae, Dromornithidae, Emeidae, Eleutherornithidae, and Aepyornithidae (Brodkorb, 1963). Interrelationships among these families have long been among the most controversial problems in avian systematics (Bock, 1963), as has the question of whether these flightless birds share a common ancestor. (References to much of the relevant literature are contained in Bock, 1963, de Beer, 1956, 1964, and Parkes and Clark, 1966). Some recent authors (e.g., Bock, 1963; Parkes and Clark, 1966) have argued that the ratites are probably monophyletic, but ornithologists have yet to reach a consensus on this point.

The tinamous (Tinamidae) are ground-dwelling, chicken-like birds of the Neotropics. Their possible close relationship to the ratites, and particularly to the rheas, has received much attention, but relationships within the Tinamidae have been largely ignored.

Because chick color patterns have been used to elucidate relationships within certain other taxa (e.g., Podicipedidae: Storer, 1967; Anatidae: Delacour and Mayr, 1945; Tetraoninae: Short, 1967; Charadrii: Jehl, 1968) their importance in suggesting relationships within the ratites and tinamous was investigated. The results provide limited evidence in support of relationships that have been suggested among ratites, and they clarify the subdivisions of the tinamous.

In this study I was able to examine specimens or descriptions of most ratite species, as well as living chicks of *Struthio camelus*, *Dromiceius novaehollandiae* and *Crypturellus soui* in the San Diego Zoo. Most tinamou genera were also available, but many species were not. Studies in other groups have shown that an index to color pattern within a genus can usually be obtained from a few representative species. Thus, the general conclusions reached here are unlikely to be affected by the limited material. Nevertheless, further collecting is desirable, particularly of species in the genera *Nothoprocta*, *Crypturellus*, and *Taoniscus*.

In the following section the major color patterns are described for each taxon. For each species the number of specimens examined is given in parentheses. Species for which I have examined only a description in the literature are denoted by an asterisk. In view of the limited material, no attempt has been made to provide descriptions adequate for species identification.

RATITES

STRUTHIONIFORMES: STRUTHIONIDAE

Struthio: camelus (2)

Ostrich chicks (Fig. 1A) are covered on the back with a thick mat of tan and blackish down feathers. Several barbs on each of these feathers are prolonged, flattened, and

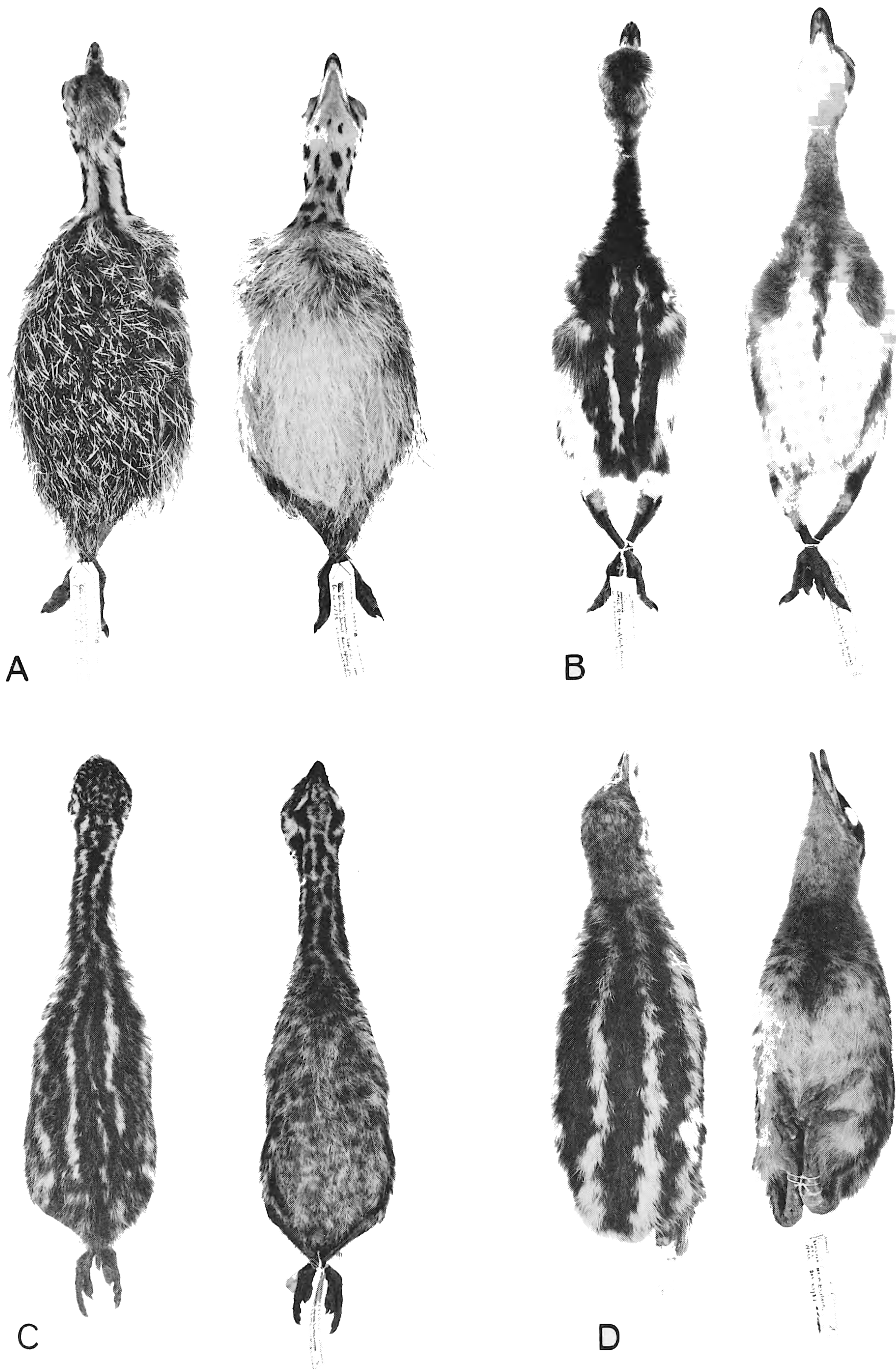

Figure 1. Downy young ratites in dorsal and ventral view: (A): *Struthio camelus* (B) *Pterocnemia pennata*, (C) *Dromiceius novaehollandiae*, (D) *Casuarius bennetti*.

THIS PAGE IS LOCKED TO FREE MEMBERS
Purchase full membership to immediately unlock this page

DELVE INTO FANTASY, MAGIC, MYTHOLOGY & FOLKLORE

Forgotten Books'
Full Membership gives
access to 797,885 ancient
and modern, fiction and
non-fiction books.

Continue

*Fair usage policy applies

but Rand and Gilliard (1967) recognize only three.

Cassowary chicks are pale brown with well-marked longitudinal stripes on the back. The head is chestnut or tan, and may be unmarked or dotted irregularly with dark brown markings (Figs. 1D, 3B). On the back three major dark brown stripes extend from the shoulder region to the rump; within each of these stripes a light central stripe of varying prominence is formed by the chestnut tips of the feathers. A dark stripe on the side is paralleled ventrally by an indistinct stripe that appears to be continuous with the leg stripe. The belly and chin range from light tan to light brown and are unmarked. The neck and chest are irregularly flecked with gray-brown markings; in most specimens the neck coloration continues on to the chest as a thin central line, similar to that found in the Rheidae (cf. Figs. 1B, D).

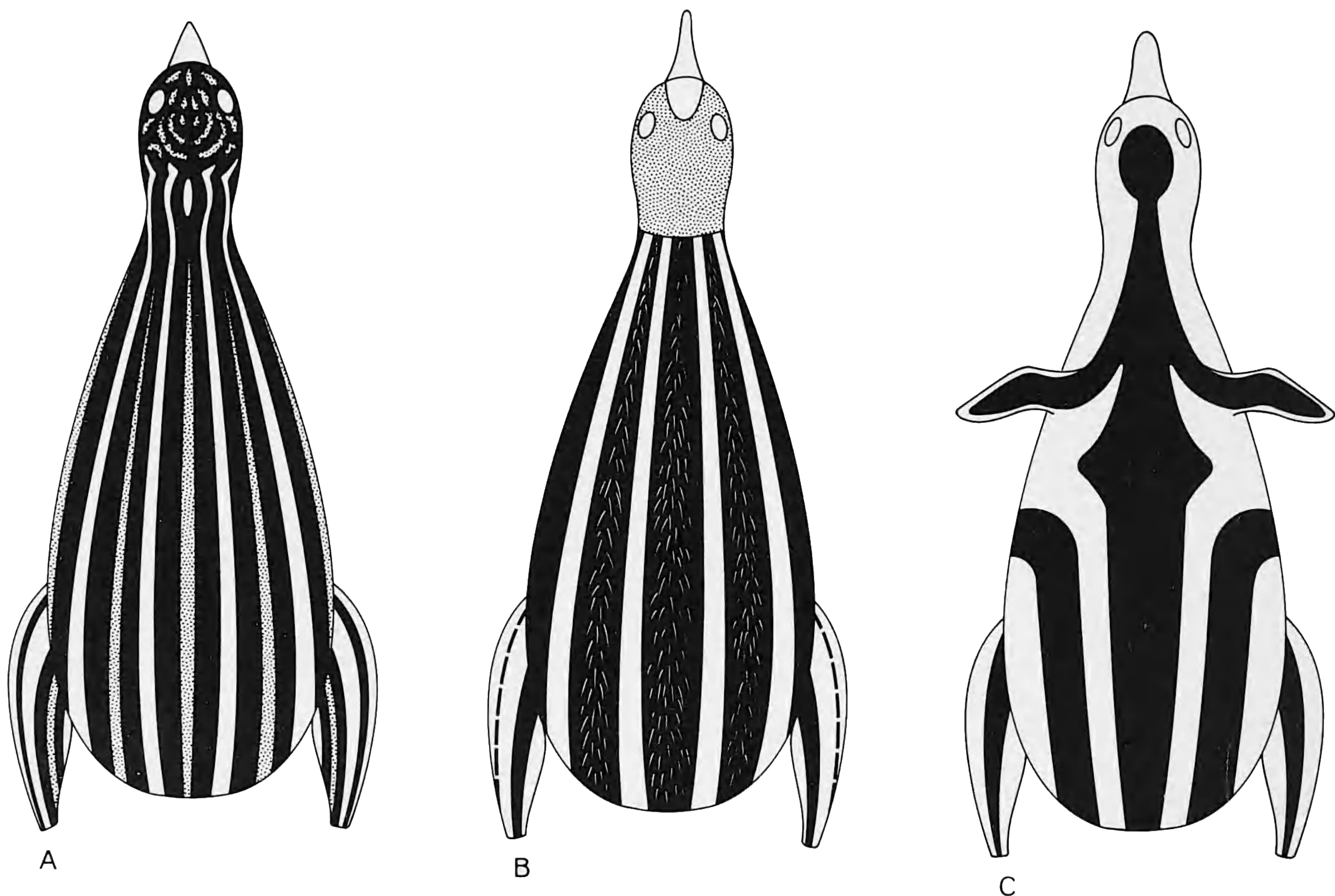

Figure 3. Diagrammatic color patterns of: (A) *Dromiceius novaehollandiae*, (B) *Casuarius casuarius*, and (C) *Pterocnemia pennata*.

Dromiceius: novaehollandiae (5)

Emu chicks are boldly patterned (Figs. 1C, 3A, 4). The head markings show no consistent arrangement but the neck and back markings are distinctive. Dorsally, a central (A) and two lateral (B) stripes extend from the occiput to the rump; a stripe from the auricular region broadens at the shoulder, where it acquires a buffy central stripe, and continues to the flank; a buff-centered stripe on the lateral surface of the thigh is bordered by a thin (sometimes interrupted) black stripe on the antero-lateral surface. On the ventral surface of the neck stripes run from the base of the bill to the sides of the chest (D); a short central stripe (E) is present in the throat region. Pattern details are variable. In some birds parts of stripes are interrupted or missing, and in the bird shown in Figure 4 the posterior part of the central stripe has fused with a lateral stripe.

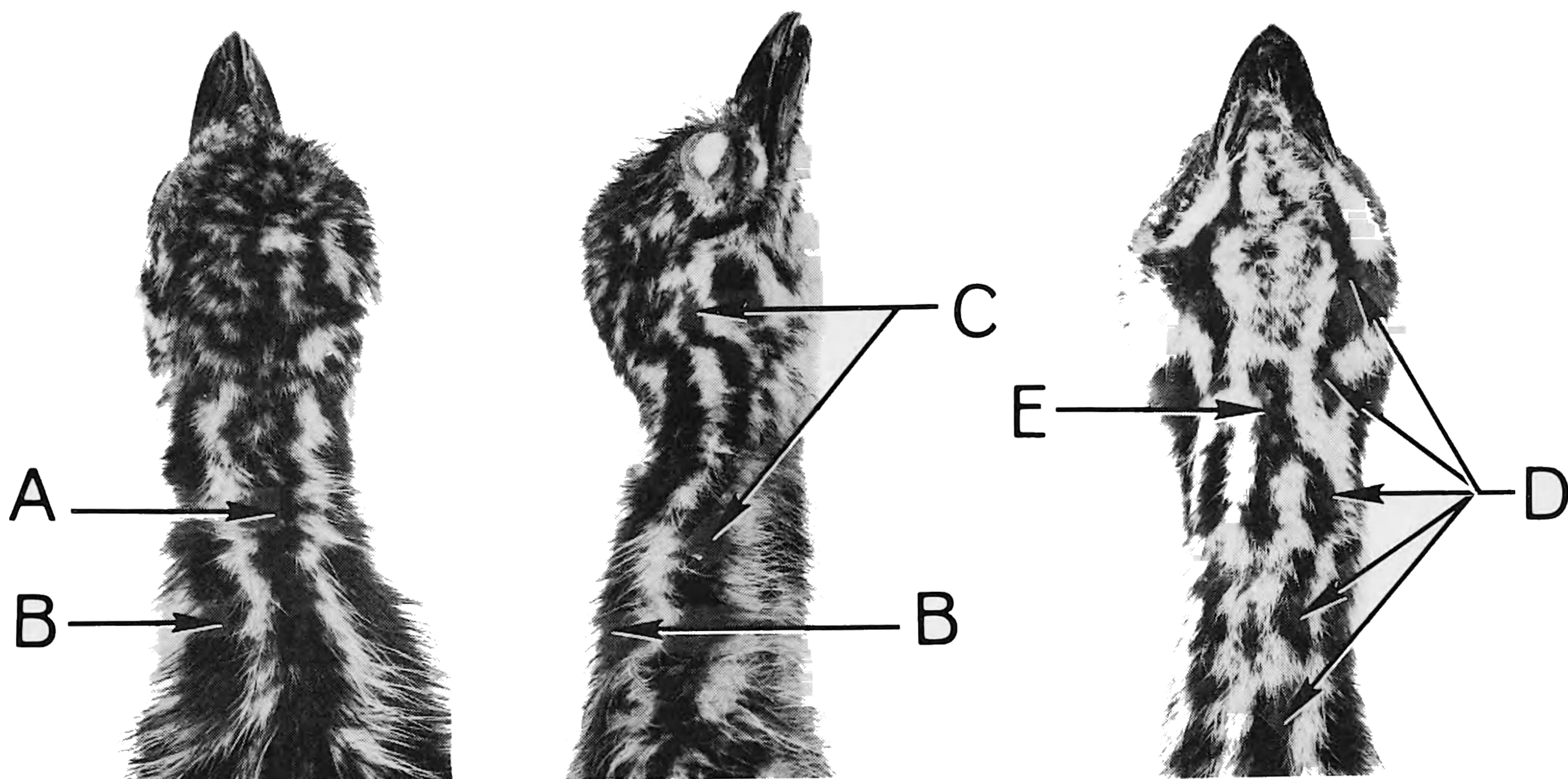

Figure 4. Head and neck pattern of *Dromiceius novaehollandiae*. The major stripes are indicated.

APTERYGIFORMES: APTERYGIDAE

*Apteryx: australis**, *oweni*, *haasti*

Newly-hatched Kiwis seem to be unpatterned. No trace of a color pattern could be detected in a well-developed embryo of *Apteryx australis* preserved in alcohol at the Carnegie Museum (Mary H. Clench, pers. comm.). Oliver (1957: 48) described the nestling of *Apteryx australis* as follows: "Upper surface black streaked with brown mainly on the shafts and bases of the feathers. On the head, breast and abdomen it is greyer."

TINAMOUS

TINAMIFORMES: TINAMIDAE

Tinamus: tao, *solitarius**, *osgoodi*, *major* (5), *guttatus*

De Schauensee's (1966) classification of tinamous is followed in this paper.

The head pattern in *T. major* is complex (Figs. 5, 6); a grayish patch extends from the base of the bill onto the forehead; posteriorly, a brown crown patch extends over the occiput and onto the neck; a gray-brown postorbital stripe runs from above and behind the eye to the side of the neck; a brownish line of variable prominence extends from the base of the bill to the anterior corner of the eye and continues posteriorly as a broad band through the auriculars; the cheeks and throat are grayish, except for a short, dark malar stripe. Feathers on the nape of the upper back are brown, lightly barred with gray, whereas those on the midback appear uniformly brown. A broad, light brown or golden band on the lower back extends to the rump and is bordered laterally by a thin line of dark feathers (Fig. 5). The color pattern of *T. solitarius* is similar (Salvadori, 1895: 502).

Nothocercus: bonapartei (1), *julius* (1), *nigricapillus*

The coloration of the two species of *Nothocercus* at hand differs slightly, but there are no important differences in color pattern. In *N. bonapartei* (Figs. 5, 6) a light grayish patch from the base of the bill extends onto the forehead, where it blends with a dark gray crown that extends onto the occiput; the face and cheeks, including a broad supraorbital stripe, are grayish, and an obscure dark line runs from the base of the bill to the anterior corner

of the eye; the throat is grayish-white. The back is uniformly brown, individual feathers being thinly barred with black. In *N. julius* the crown patch is grayish-white and is sharply bordered laterally by a dark stripe; the facial area is orangish.

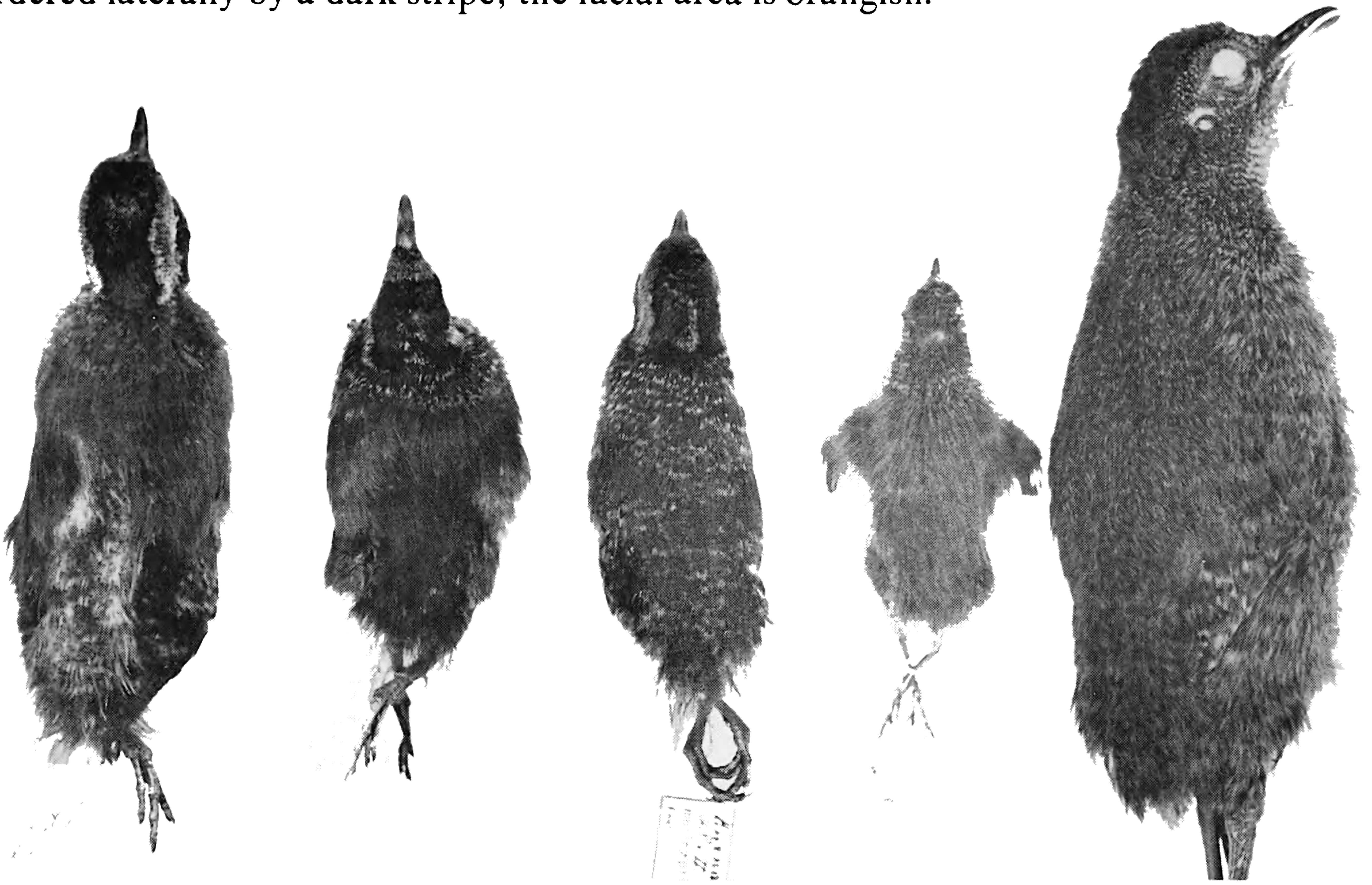

Figure 5. Downy young tinamous. Left to right: *Tinamus major*, *Crypturellus boucardi*, *Crypturellus undulatus*, *Crypturellus soui*, *Nothocercus bonapartei*.

Crypturellus: *cinereus*, *soui* (2), *ptaritepui*, *obsoletus*, *undulatus* (1), *brevirostris*, *bartletti*, *variegatus* (2), *atrocapillus*, *noctivagus*, *duidae*, *cinnamomeus* (1), *transfasciatus*, *strigulosus*, *casiaquiare*, *boucardi* (2), *saltuarius*, *kerriae*, *parvirostris*, *tataupa* (2)

Color patterns in this large genus are variable (Figs. 5, 6). In *C. boucardi*, *variegatus*, *cinnamomeus*, *tataupa* and *undulatus*, the head pattern is similar to that of *Tinamus* except that a light brown narrow median stripe is enclosed in the posterior part of the crown

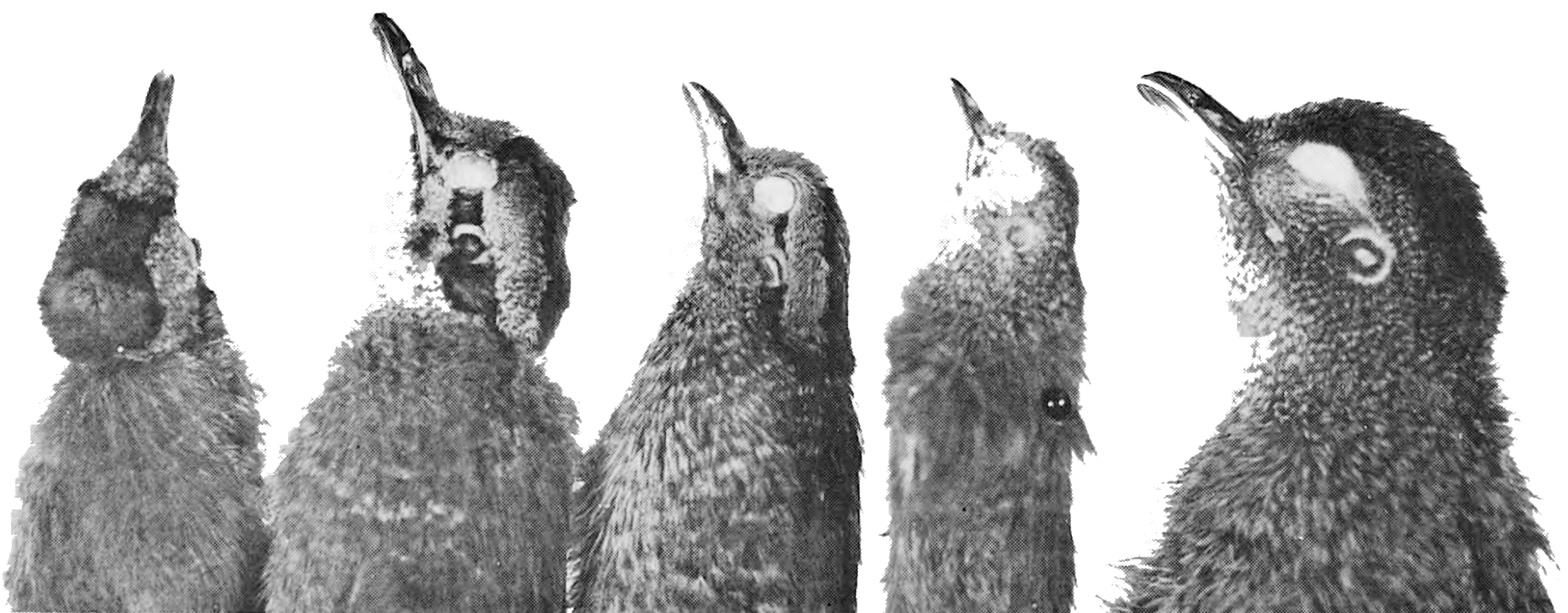

Figure 6. Head patterns of tinamou chicks. Left to right: *Tinamus major* (2), *Crypturellus undulatus*, *Crypturellus soui*, *Nothocercus bonapartei*.

THIS PAGE IS LOCKED TO FREE MEMBERS
Purchase full membership to immediately unlock this page

FORGOTTEN BOOKS

FULL MEMBERSHIP

797,885 Books!
All you can read
for only
\$8.99/month

Continue

*Fair usage policy applies



vious pattern and to be overlain by a thin coat of stiff bristles. This streaked pattern reflects the structure of the dorsal down feather, which consists of a rachidial main feather and a prominent aftershaft of almost equal size. The rachis of the main feather bears dark-colored barbs for about two-thirds of its length, then forks to form a pair of stiff bristles; the aftershaft bears light colored barbs for almost its entire length. A similar down structure is present in *Nothura*, *Nothoprocta*, and *Eudromia*. In down feathers of *Tinamus*, *Nothocercus* and *Crypturellus*, a rachis is poorly developed and aftershafts seem to be lacking or rudimentary.

The head pattern is well defined. A narrow blackish crown patch which extends from above the eye to the occiput is bordered by a thin buffy stripe that begins at the base of the bill but forks on the forehead to encircle the crown patch; the buffy stripes, in turn, are bordered by a dark stripe that extends from the base of the bill to the nape. The face is generally buffy, but with interrupted dark stripes in the post-orbital and auricular regions; there is a thin malar stripe (Fig. 8).

Nothoprocta: taczanowskii, kalinowski, ornata (1); *perdicaria* (1), *cinerascens, pentlandii* (2), *curvirostris* (3)

Chicks of *Nothoprocta* (Figs. 7, 8), like those of *Rhynchotus* have a streaked pattern. In *Nothoprocta*, however, the bristle-like tips of the main feather are much less prominent and usually are flanked by one or more additional barbs. The chick of *N. perdicaria*, in addition to being streaked dorsally, has a slightly barred appearance, because the dark feathers are buffy at both the base and tip.

The head markings in *perdicaria* and *ornata* are similar to those of *Rhynchotus*, except that the boundaries between the major stripes are less pronounced. In *curvirostris* and *pentlandii* the head is dotted irregularly with black, brown, and white, but the pattern is a variation of that found in *perdicaria*.

Nothura: boraquira, minor, darwinii, maculosa (1), *chacoensis*

The chick of *Nothura maculosa* (Figs. 7, 8) also has a streaked pattern and is extremely similar to that of *Rhynchotus*; the hairlike bristles of the dark back feathers, however, are less strongly developed than in that genus. The head pattern is like that of *Rhynchotus*, except that the borders between the major stripes are less clearly defined. *Nothura* lacks a post-orbital stripe; auricular and malar stripes, though present, are inconspicuous.

Taoniscus: nanus

I have seen neither a chick nor a description of the downy plumage of this species.

Eudromia: elegans (5), *formosa*

The dorsal color pattern of *Eudromia* (Fig. 7) is similar to that of the other streaked genera, although light-colored feathers are less abundant than in *Rhynchotus*, *Nothoprocta* and *Nothura*. The darker feathers are subterminally barred with blackish brown, so that the chick, like that of *Nothoprocta perdicaria*, appears slightly barred. The bare tips of these feathers are much shorter than in the genera listed above.

The dorsal surface of the head and neck is flecked with gray and brown; from each side of the bill an indistinct whitish line extends across the crown to the occiput; the face and throat are generally buffy-white, but the lores are dark; posterior to the eye a brown stripe extends through the auriculars to the side of the neck; there is prominent malar stripe (Fig. 8).

Tinamotis: pentlandii (3), *ingoufi*

So little down remains on the three half-grown chicks of *T. pentlandii* that I have ex-

amined that no assessment of the body pattern is possible. The head, however, is boldly striped. Two broad dark stripes, one on each side of the bill, pass dorsal to the eyes and around the periphery of the crown to the nape; a small white-centered patch on the occiput extends onto the nape as a thin median line; a stripe from the lores passes through the eye to the auricular region; and a malar stripe extends from the gape through the cheeks and onto the side of the neck. At first glance the head markings of *Tinamotis* seem unique but the pattern is clearly a variant of those found in genera with streaked chick plumages and closely resembles that of *Nothoprocta perdicaria*.

DISCUSSION

RATITES.—In the following discussion I assume that similarities in complex patterns and the potential for easy transformation of one pattern to another are evidence for close relationship. The sequence of pattern transformation cannot be determined in the absence of information regarding the ancestral downy pattern. However, if one assumes that the ratites are monophyletic, it is reasonable to infer that a striped pattern of some sort may have been primitive, inasmuch as a striped pattern or presumed remnant thereof is present in four of the five extant ratite families and is lacking only in the Kiwis, whose burrow-nesting habits are unusual in that group.

The downy young plumages provide limited evidence regarding relationships among ratite families. The long-accepted close affinity of cassowaries and emus is confirmed by the similar color patterns of their chicks. The transformation of a cassowary pattern to that of an emu requires only a change in head pattern (variable in cassowaries) and the introduction of a light central stripe to each of the major dorsal stripes. A hint of that line—the light chestnut tips to the central feathers of each stripe—is present in the cassowaries.

Ostrich chicks lack any discernible dorsal pattern, but the pattern of head and neck striping is closely similar to that of an emu (cf. Figs. 2, 4). This suggests, as Sibley (1960) and Glenny (1965) have indicated, that the Struthioniformes and Casuariiformes may be more closely related to each other than either is to any other living ratite order. If so, the neck pattern in ostriches might represent the remnant of a striped pattern that extended over much of the body. One could speculate that this pattern was replaced by a uniform pattern, and was complemented by a straw-like down structure, insuring crypticity in areas of sparse vegetation as proto-ostriches became adapted to desert habitats.

Downy plumage patterns do not suggest an alliance between rheas and other ratites. Although it would be possible to derive the striped rhea pattern from that of a cassowary, for example, no easy transformation is evident. Similar chest patterns in rheas and cassowaries are simple and could result from convergence. Thus, they provide no evidence for relationship.

Kiwis are thought to be most closely related to the extinct moas and to the living cassowaries and emus (Parkes and Clark, 1966). Young kiwis are unpatterned and their plumage offers no evidence on their possible relationship to other ratites. The lack of a distinct pattern may be a derived condition associated with the burrow-nesting habits of these birds.

TINAMOUS.—Downy young tinamous fall into two distinct groups of genera: 1) *Tinamus*, *Nothocercus*, and *Crypturellus*; 2) *Rhynchotus*, *Nothura*, *Nothoprocta*, *Eudromia*, and *Tinamotis*. Chicks of *Taoniscus* (not available) presumably fall into the second group. These groups correspond to the subfamilies Tinaminae and Nothurinae, respectively, of Miranda-Ribiero (1938). The downy young provide no evidence for von Boetticher's

(1934) subdivision of the Nothurinae into two subfamilies, Rhynochotinae (*Rhynochotus*, *Nothura*, *Nothoprocta*, *Taoniscus*) and Eudromiinae (*Eudromia*, *Tinamotis*).

Because the Tinaminae are forest dwellers whereas the Nothurinae are birds of the grasslands, pattern similarities within these groups might be attributable to convergence. This seems unlikely because patterns in the Tinaminae are complex, and the *Tinamus* pattern can be easily transformed into the more uniform pattern of *Nothocercus* through a small series of steps such as are represented in existing species of *Crypturellus* (Figs. 5, 6). Chicks of the Nothurinae are united by similarities in back pattern and feature structure; differences between color patterns of *Rhynochotus* and *Eudromia* are largely bridged by intermediate patterns within *Nothoprocta* (Figs. 7, 8).

Interrelationships of tinamou genera diagrammed by von Boetticher (1934; also reproduced in Ward, 1957: 336) are largely supported by Ward's study of mallophagan parasites on tinamous. Ward's suggestion that *Nothocercus* is more closely related to *Crypturellus* than to *Tinamus*, however, is also indicated by the similarity of chick color patterns. In addition, chick plumages suggest that *Nothoprocta* may be somewhat more closely allied to *Eudromia* (and *Taoniscus*) than von Boetticher postulated. In the species that I have examined there are no close similarities between patterns in the Tinaminae and Nothurinae.

The attempt to establish a phylogenetic link between the ratites and tinamous, and particularly between the rheas and tinamous, dates at least to the early 19th century, and the downy young have been used to give some support to that view. Salvadori (1895: 494) stated that newly hatched tinamous "... are covered with down, and more or less closely resemble the young of some of the Ratitae." While I agree with Salvadori's implicit thesis—that the downy plumages of birds may be of great taxonomic value—I differ with his conclusion. Nowhere among the tinamous that I have examined, nor in species whose chicks are described by Salvadori, are there patterns resembling those of rheas or any other ratite. This evidence, of course, cannot be used to refute the possibility that tinamous may be more closely related to rheas than to any other living taxon, but neither does it provide any support for that hypothesis. Whether analyses of other taxa with precocial young might suggest alternate relationships for the Tinamiformes (e.g., Galliformes, see Verheyen, 1960; Chandler, 1916) is problematical but worthy of investigation.

ACKNOWLEDGMENTS

Specimens used in this study were borrowed from or examined at the American Museum of Natural History, Carnegie Museum, The University of Kansas Museum of Zoology, The University of Michigan Museum of Zoology, Peabody Museum, Museum of Vertebrate Zoology, Field Museum of Natural History, Philadelphia Academy of Sciences, Los Angeles County Museum, and San Diego Natural History Museum. I am indebted to the curators of these collections for their assistance. I am also grateful to K. C. Lint and James Dolan for making the facilities of the San Diego Zoo available to me.

K. C. Parks, R. W. Storer, J. Strauch, G. A. Clark, Jr., W. Bock, P. Devillers, and J. Cracraft provided useful criticisms of the manuscript.

LITERATURE CITED

- Beebe, W.
1925. The Variegated Tinamous *Crypturus variegatus variegatus* (Gmelin). *Zoologica* 6(2): 195-227.
- Bock, W. J.
1963. The cranial evidence for ratite affinities. *Proc. XIII Intern. Ornithol. Cong.*: 39-54.
- Boetticher, H. von.
1934. Beiträge zu einem phylogenetisch begründeten natürlichen System der Steisshühner (Tinami) auf Grund einer taxonomisch verwarbaren Charaktere. *Jenaische Zeits. für Naturwiss.* 69: 169-192.
- Brodkorb, P.
1963. Catalogue of fossil birds. *Bull. Florida State Mus.* 7(4): 179-293.

THIS PAGE IS LOCKED TO FREE MEMBERS
Purchase full membership to immediately unlock this page

DELVE INTO FANTASY, MAGIC, MYTHOLOGY & FOLKLORE

Forgotten Books'
Full Membership gives
access to 797,885 ancient
and modern, fiction and
non-fiction books.

Continue

*Fair usage policy applies

**CENOZOIC CALCAREOUS NANNOFOSSILS
FROM THE PACIFIC OCEAN**

DAVID BUKRY

TRANSACTIONS

**OF THE SAN DIEGO
SOCIETY OF
NATURAL HISTORY**

VOL. 16, NO. 14

7 DECEMBER 1971

THIS PAGE IS LOCKED TO FREE MEMBERS
Purchase full membership to immediately unlock this page

FORGOTTEN BOOKS

FULL MEMBERSHIP

797,885 Books!
All you can read
for only
\$8.99/month

Continue

*Fair usage policy applies



Bukry and Bramlette, 1970; Milow, 1970; Roth, 1970; Bukry, 1971; and Martini and Worsley, 1971. Because nannofossils are small and occur in vast numbers in a given sample, the whole assemblage can be scanned in a few minutes. Therefore, it is convenient to base zonal identifications on the character of the whole assemblage. Boundaries of zonal units (table 1) can usually be identified by closely spaced first and last occurrences of several species. Some of the key species used to recognize zone and subzone boundaries are indicated in tables 2 and 3. A full discussion of the character of these zonal units is given in the report on nannofossil stratigraphy for Deep Sea Drilling Project Leg 16 that explored the eastern equatorial Pacific Ocean (Bukry, in press).

NANNOFOSSIL DISSOLUTION

The diversity of species that compose nanoplankton assemblages is, to a large extent, controlled by selective dissolution of skeletal elements between the time of death in surface water and the time of final burial below the ocean bottom. Skeletal elements that bypass or survive ingestion by nanoplankton herbivores—microscopic, planktonic protozoans such as foraminifers and radiolarians (Tappan, 1971)—owing to their calcite composition are subjected to increased inorganic dissolution rates in progressively more calcite-undersaturated water at progressively greater ocean depth (Peterson, 1966). Although Berger (1970) has estimated that about four-fifths of the calcite supplied to the ocean floor is being redissolved, nanoplankton skeletons are more resistant to this effect than are other calcite microplankton skeletons. Part of their resistance to dissolution may be the result of incorporation of acid-resistant, fibrillar, cellulose-like polysaccharide material with the skeletal calcite (Franke and Brown, 1971). Chave and Suess (1967) have stated that organic coatings inhibit the precipitation of calcium carbonate on carbonate surfaces. Such coatings that inhibit carbonate-sea water interactions probably also retard dissolution of calcium carbonate particles in undersaturated water (Smith et al., 1968; Pytkowicz, 1969).

In addition to the possible organic coatings, variation in nanoplankton skeletal thickness relative to optic-axis orientation apparently accounts for some of the solution resistance of nanoplankton. Some of the most resistant taxa have a similar relation between the exposed surfaces and optic-axis orientation of their calcite crystallites. *Discoaster* and the upper shields of the placoliths *Coccolithus* and *Cyclococcolithina* are typically the last remnants of a strongly dissolved fossil nanoplankton assemblage. In cross-polarized light, all of these appear dark because of the vertical orientation of the principal optic axis of their crystallites. Differences in dissolution rates along different crystallite axes, in conjunction with variation in crystallite thickness, could cause a significant range of structural differences to explain selective solution along taxonomic groupings.

The most diverse assemblages, those from warm-water areas that are little affected by calcite undersaturation, occur in deposits from the sublittoral shelf to the basal continental slope (approx. depths 50-2000 m). Such assemblages, which may contain common pentagonally-shaped *Braarudosphaera* or *Micrantholithus* (JOIDES Blake Plateau cores, for example), have been characterized as "nearshore" (Bramlette and Martini, 1964). As these nanoplankton are distinctively shaped, their general absence in deep-ocean (2000-6000 m) sediment is easy to determine. Indeed, some of these presumed nearshore indicator taxa have been reported in mid-ocean plankton and island samples, for example, *Braarudosphaera* in North Atlantic water (Hulburt, 1962; Hulburt and Rodman, 1963) and *Braarudosphaera* and *Micrantholithus* in shallow-water sediment from the Tonga Islands (Bramlette, 1970), suggesting that they are not restricted to inshore areas by envi-

ronmental factors while they are alive. Instead, these forms are probably poorly resistant to solution. Their spotty and far-flung distribution suggests that they are preserved in shallow (near-saturated) depositional areas and dissolved in deep (undersaturated) areas.

Table 1. Cenozoic calcareous nannoplankton zones and subzones. Approximate ages of series and subseries in million years from Berggren (1971).

SERIES OR SUBSERIES	AGE M. Y.	ZONE	SUBZONE
HOLOCENE	0.01	<i>Emiliana huxleyi</i>	
PLEISTOCENE	1.85	<i>Gephyrocapsa oceanica</i>	
		<i>Coccolithus daronicoides</i>	<i>Gephyrocapsa caribbeanica</i> <i>Emiliana annula</i>
UPPER PLIOCENE	3.7	<i>Discoaster broweri</i>	<i>Cyclococcolithina macintyreii</i> <i>Discoaster pentaradiatus</i> <i>Discoaster tamalis</i>
		<i>Reticulofenestra pseudumbilica</i>	<i>Discoaster asymmetricus</i> <i>Sphenolithus neoabies</i>
LOWER PLIOCENE	5.1	<i>Ceratolithus tricorniculatus</i>	<i>Ceratolithus rugosus</i> <i>Ceratolithus amplificus</i> <i>Triquetrorhabdulus rugosus</i>
		<i>Discoaster quinquerramus</i>	<i>Ceratolithus primus</i> <i>Discoaster berggrenii</i>
UPPER MIOCENE	10.5	<i>Discoaster neohamatus</i>	<i>Discoaster neorectus</i> <i>Discoaster bellus</i>
		<i>Discoaster hamatus</i>	
MIDDLE MIOCENE	14	<i>Catinaster coalitus</i>	
		<i>Discoaster exilis</i>	<i>Discoaster kugleri</i> <i>Coccolithus miopelagicus</i>
LOWER MIOCENE	22.5	<i>Sphenolithus heteromorphus</i>	
		<i>Helicopontosphaera ampliapertura</i>	
OLIGOCENE	38	<i>Sphenolithus belemnus</i>	
		<i>Triquetrorhabdulus carinatus</i>	<i>Discoaster druggii</i> <i>Discoaster deflandrei</i> <i>Dictyococcites abisectus</i>
UPPER EOCENE	45	<i>Sphenolithus ciperensis</i>	
		<i>Sphenolithus distentus</i>	
MIDDLE EOCENE	49	<i>Sphenolithus predistentus</i>	
		<i>Helicopontosphaera reticulata</i>	<i>Cyclococcolithina formosa</i> <i>Coccolithus subdistichus</i>
LOWER EOCENE	53.5	<i>Discoaster barbadiensis</i>	<i>Cyclicargolithus reticulatus</i> <i>Discoaster tani tani</i>
		<i>Reticulofenestra umbilica</i>	
PALEOCENE	65	<i>Nannotetrina quadrata</i>	<i>Coccolithus staurion</i> <i>Chiasmolithus gigas</i> <i>Discoaster mirus</i>
		<i>Discoaster sublodoensis</i>	
PALEOCENE	65	<i>Discoasteroides kuepperi</i>	
		<i>Discoaster lodoensis</i>	
PALEOCENE	65	<i>Tribrachiatus orthostylus</i>	
		<i>Discoaster diastypus</i>	
PALEOCENE	65	<i>Discoaster multiradiatus</i>	<i>Campylosphaera eodela</i> <i>Chiasmolithus bidens</i>
		<i>Discoaster nobilis</i>	
PALEOCENE	65	<i>Discoaster mohleri</i>	
		<i>Heliolithus kleinpelli</i>	
PALEOCENE	65	<i>Fasciculithus tympaniformis</i>	
		<i>Cruciplacolithus tenuis</i>	

THIS PAGE IS LOCKED TO FREE MEMBERS
Purchase full membership to immediately unlock this page

DELVE INTO FANTASY, MAGIC, MYTHOLOGY & FOLKLORE

Forgotten Books'
Full Membership gives
access to 797,885 ancient
and modern, fiction and
non-fiction books.

Continue

*Fair usage policy applies

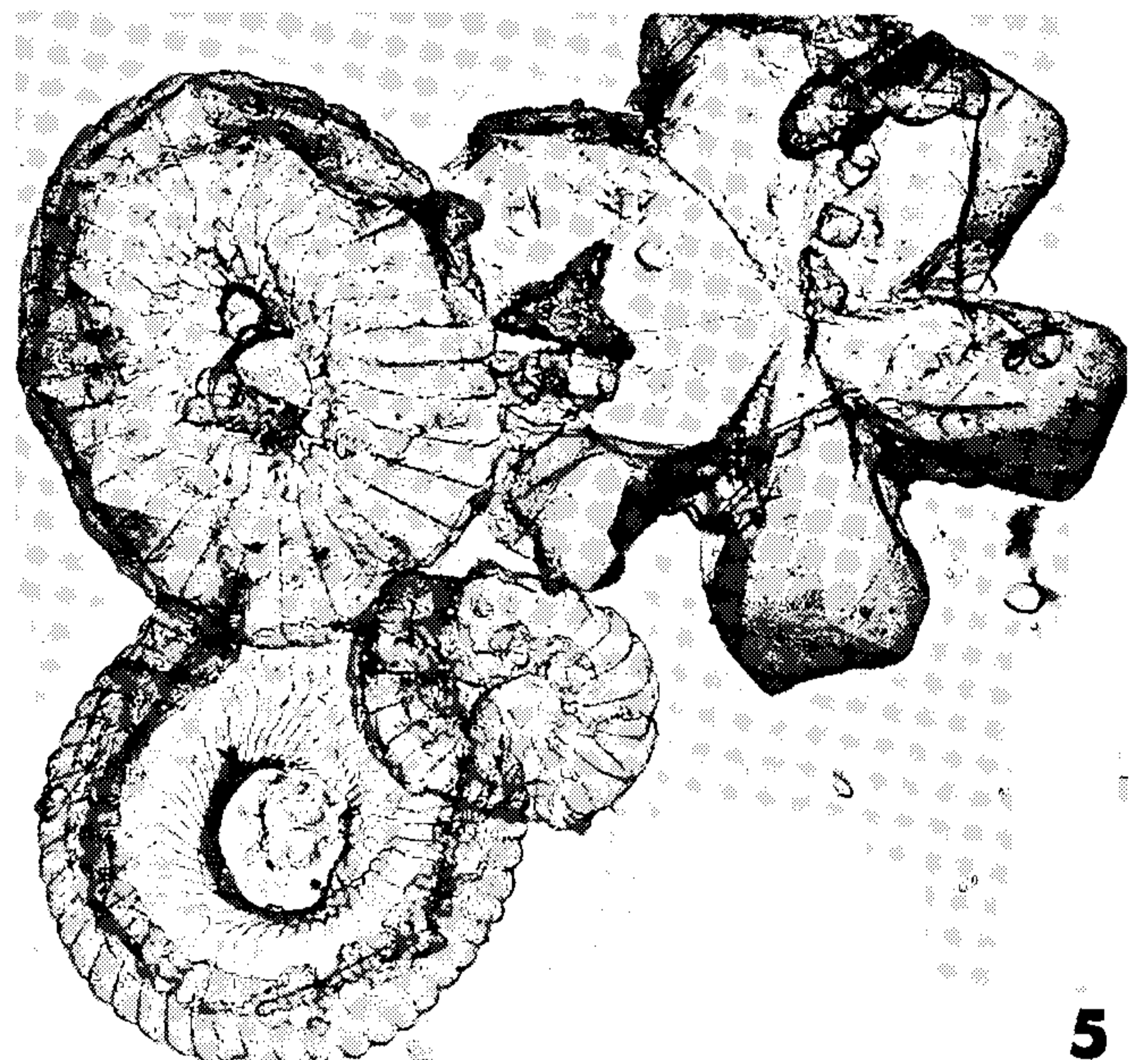
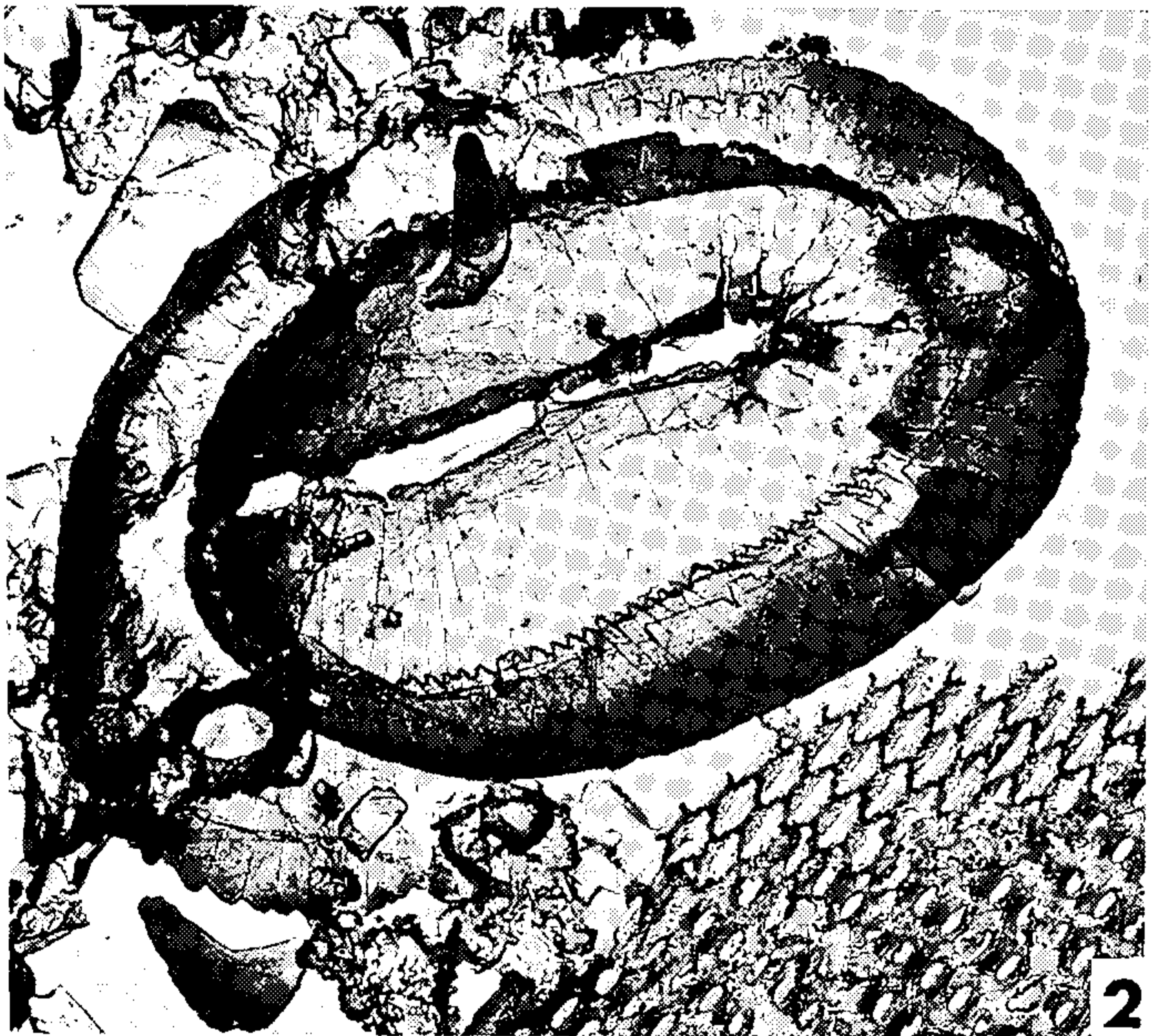
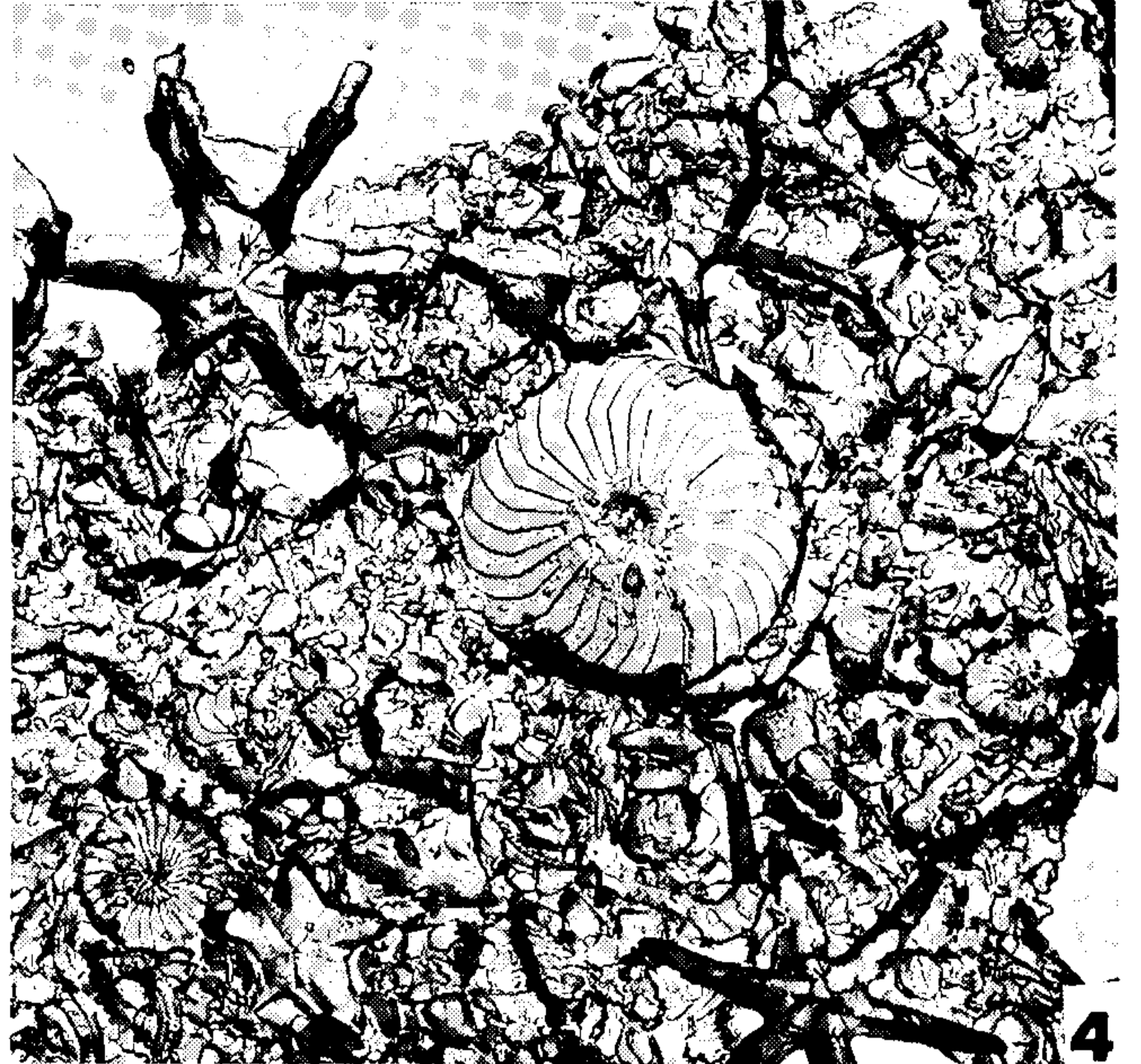

cur at the shallow site alone.

Lower Pleistocene *Coccolithus daronicoides* Zone:

Discoaster perplexus, *Helicopontosphaera sellii*, *Oolithotus antillarum*, *Rhabdosphaera clavigera*, *Umblicosphaera mirabilis*.

Upper Pliocene *Discoaster brouweri* Zone:

Discoaster perplexus, *Helicopontosphaera sellii*, *Oolithotus antillarum*, *Scyphosphaera apsteinii*, *S. intermedia*, *Thoracosphaera* spp.

Lower Pliocene *Reticulofenestra pseudoumbilica* Zone:

Discoaster perplexus, *Discolithina japonica*, *Helicopontosphaera kamptneri*, *H. sellii*, *Oolithotus antillarum*, *Scyphosphaera apsteinii*, *S. globulata*, *S. pulcherrima*, *Thoracosphaera* spp.

Upper Miocene *Discoaster quinquedentatus* Zone:

Discoaster perplexus, *Discolithina japonica*, *Helicopontosphaera kamptneri*, *Scyphosphaera intermedia*, *Sphenolithus abies*, *Thoracosphaera* spp.

Middle Miocene *Discoaster hamatus* Zone:

Discoaster perplexus, *Helicopontosphaera kamptneri*, *Scyphosphaera* sp. cf. *S. pulcherrima*, *Sphenolithus abies*.

Establishing the relative order of nannofossil dissolution is important to provide information for interpreting the paleoecology of the assemblages (Douglas, 1971; Lawrence, 1971), and to improve precision in stratigraphic zonation.

SYSTEMATIC PALEONTOLOGY

Genus *Coccolithus* Schwarz, 1894

***Coccolithus magnicrassus* n. sp.**

Pl. 2, figs. 1-5

Description.—This large, elliptic placolith is characterized by a small central area and a broad finely striate rim. In light-microscope examination, the central area is prominent and the rim faint, being at high and low relief with respect to the mounting medium ($n = 1.518$). In cross-polarized light the central area is bright, forming a small elliptic collar around an elliptic central opening; whereas the rim is faint, with diffused strongly curving extinction bands. The upper rim has 55-80 radial crystallites, and is distinctly larger than the lower rim.

Remarks.—*Coccolithus magnicrassus* is distinguished from other similar placoliths by the combined characters of (1) large overall size; (2) small, high relief central area with simple central opening; (3) broad upper rim, composed of many elements, that is only moderately bright in cross-polarized light and has diffuse, strongly curving extinction bands. *Toweius craticulus* Hay and Mohler is smaller with a narrower rim; *Reticulofenestra hillae* Bukry and Percival has a larger central opening and in cross-polarized light a fully bright rim with broader less curved extinction bands; *Coccolithus crassus* Bramlette and Sullivan is distinctly smaller, and the upper, larger rim is dark in cross-polarized light. A comparison of *C. crassus* with *C. magnicrassus* is shown in Pl. 2, fig. 2.

Plate 1. Electronmicrographs of carbon-platinum replicas showing surface crystallite patterns of some typical forms of Cenozoic calcareous nannofossils. 1. *Syracosphaera pulchra* Lohmann, Pleistocene, Shatsky Rise, DSDP 47.0-1-4, 77-78 cm. 11,000 X. 2. *Helicopontosphaera kamptneri* Hay and Mohler, Pleistocene, Shatsky Rise, DSDP 47.0-1-4, 77-78 cm. 7,000 X. Diatom fragment at lower right corner. 3. *Rhabdosphaera clavigera* Murray and Blackman, Pleistocene, Shatsky Rise, DSDP 47.0-1-4, 77-78 cm. 8,000 X. 4. Group of placoliths and discoasters, Pliocene, Caroline Ridge, DSDP 57.2-1-6, 0-3 cm. 1,700 X. 5. Group of placoliths and a discoaster, Miocene, Caroline Ridge, DSDP 55.0-11-5, 78-80 cm. 4,000 X. 6. Group with placolith, discoaster, and sphenolith, Eocene, Horizon Ridge, DSDP 44.0-3-5, 145-150 cm. 3,000 X.

Occurrence.—*Coccolithus magnicrassus* occurs in lower Eocene marine sediment cored in the North Pacific and North Atlantic Ocean and in the Donzacq Marl of France. It does not range as high as *C. crassus*, for it is recognized only from the *Discoaster lo-doensis* Zone thus far.

Size.—16-20 microns.

Holotype.—USNM 176883 (Pl. 2, figs. 1-2).

Paratype.—USNM 176884-176886.

Type locality.—DSDP 47.2-7-3, 104-105 cm, Shatsky Rise, northwestern Pacific Ocean.

Coccolithus miopelagicus n. sp.

Pl. 2, figs. 6-9

Description.—This large placolith has a medium-sized central area and a broad distinctly striate rim. In light-microscope examination, both the rim and central area are prominent. In cross-polarized light the central area is bright with distinct extinction bands; the lower (smaller) rim is bright, but the upper rim is dark. A small simple elliptical opening or slit in the central area is aligned with the long axis of the placolith.

Remarks.—The similarly constructed species, *Coccolithus eopelagicus* (Bramlette and Riedel) is distinguished from *Coccolithus miopelagicus* by several criteria: (1) Rim counts for *C. eopelagicus* are higher, 50 to 61 instead of 40 to 49; (2) Measurement of ten typical specimens shows that the central area of *C. eopelagicus* occupies a greater percentage of the long axis, 59 ± 1 percent instead of 50 ± 5 percent; (3) The central area also occupies a greater percentage of the short axis, 49 ± 2 percent instead of 42 ± 3 percent. The general distinction of *C. miopelagicus* from *C. eopelagicus* and large specimens of the younger *C. pelagicus* (Wallich) s.s. is the distinctly smaller central area of *C. miopelagicus* with respect to the rim area. Large specimens of *C. miopelagicus* are 20 microns in major axis length, but as indicated by Bramlette and Riedel (1954) these middle Tertiary forms, similar to *C. eopelagicus*, are generally smaller.

Occurrence.—*Coccolithus miopelagicus* is most common in lower and middle Miocene sediment from the Atlantic and Pacific Oceans and Caribbean Sea. The appearance of *C. miopelagicus* populations near the Oligocene-Miocene boundary is probably a gradual transition from *C. eopelagicus* resulting from increasing temperatures. Some tropical middle Eocene *C. eopelagicus* populations have a fair percentage of associated *C. sp. cf. C. miopelagicus*, whereas lower Oligocene (cooler temperatures) and high latitude middle Eocene assemblages contain only *C. eopelagicus*. The disappearance of *C. miopelagicus* at the *Catinaster coalitus* Zone is abrupt.

Size.—13 to 18 microns.

Holotype.—USNM 176888 (Pl. 2, figs. 7-8).

Paratype.—USNM 176887, 176889.

Type locality.—DSDP 63.0-3-4, 80-81 cm, East Caroline Basin, western equatorial Pacific Ocean.

Plate 2. Photomicrographs: 2,000 X. 1-5. *Coccolithus magnicrassus*, n. sp. (1) holotype USNM 176883, DSDP 47.2-7-3, 104-105 cm; (2) holotype at left, *Coccolithus crassus* Bramlette and Sullivan at right, cross-polarized, (3) USNM 176884, (4) USNM 176885, cross-polarized, (5) USNM 176886, DSDP 47.2-7-2, 100-101 cm, cross-polarized. 6-9. *Coccolithus miopelagicus*, n. sp. (6) USNM 176887, DSDP 63.1-8-3, 80-81 cm, (7) holotype USNM 176888, DSDP 63.0-3-4, 80-81 cm, (8) holotype, cross-polarized, (9) USNM 176889, DSDP 70.0-3-3, 63-64 cm. 10-11. *Coccolithus? orangensis*, n. sp. (10) holotype USNM 176890, DSDP 55.0-13-1, 120-121 cm, (11) holotype, cross-polarized; three small *Cyclicargolithus sp. cf. C. floridanus* (Roth and Hay) with straight extinction lines are present below the holotype.

THIS PAGE IS LOCKED TO FREE MEMBERS
Purchase full membership to immediately unlock this page

FORGOTTEN BOOKS

FULL MEMBERSHIP

797,885 Books!
All you can read
for only
\$8.99/month

Continue

*Fair usage policy applies



Coccolithus? orangensis n. sp.

Pl. 2, fig. 10; Pl. 3, figs. 1-3

Description.—This small elliptic placolith has exceptionally high relief with respect to the mounting medium ($n = 1.518$). Individual crystallites are not discernible by light microscope. In cross-polarized light, the coccolith is bright except for a small central opening. The extinction bands are strongly curved and become abruptly diffused in a narrow margin at the outer perimeter that is slightly brighter than the rest of the nannofossil.

Remarks.—*Coccolithus? orangensis* is not readily assignable to any presently described genus. What might be a side view of this species is shown at the right side of figure 1-2 of Plate 3. The exceptionally high relief, characteristically exceeding that of discoasters, small size, and bright perimeter help to distinguish *C.? orangensis* from other elliptic nannofossils. There appears to be a narrow, high relief collar structure around the small central opening, resulting in a ring-like depression between the perimeter and collar. *C.? orangensis* is distinguished from *Cyclicargolithus floridanus* (Roth and Hay) by its elliptic outline, high relief, and bright perimeter.

Occurrence.—*Coccolithus? orangensis* is never abundant but is a consistent low-frequency member of upper Oligocene and lower Miocene assemblages assigned to the *Sphenolithus ciperensis* Zone and *Triquetrorhabdulus carinatus* Zone. It occurs in both Pacific and Atlantic Ocean deep-sea cores.

Size.—4 to 6 microns.

Holotype.—USNM 176890 (Pl. 2, figs. 10-11).

Paratypes.—USNM 176891-176892.

Type locality.—DSDP 55.0-13-1, 120-121 cm, Caroline Rise, western equatorial Pacific Ocean.

Cyclicargolithus n. gen.

Description.—Circular to subcircular placoliths constructed of two shields connected by a central tube that may be closed or open. In plan view, the upper shield is bright in cross-polarized light.

Type species.—*Coccolithus floridanus* Roth and Hay in Hay and others, 1967, Gulf Coast Assoc. Geol. Socs. Trans., v. 17, p. 455, Pl. 6, figs. 1-4.

Remarks.—The genus *Cyclococcolithina* Wilcoxon (1970) included circular to subcircular forms of two kinds—those with dark upper shields and those with bright upper shields when viewed in cross-polarized light. The significant difference in the orientation of the optic axis of the shield crystallites that accounts for this distinction is considered to be of generic rank. Therefore *Cyclococcolithina* Wilcoxon is herein restricted to those forms having dark upper shields such as *Cyclococcolithinaiformosa* and the type species *Cyclococcolithina leptopora*. Forms with bright upper shields are transferred to *Cyclicargolithus*. The circular to subcircular outline of this genus distinguishes it from elliptical *Coccolithus* Schwarz, which has a dark upper shield in cross-polarized light.

Cyclicargolithus floridanus (Roth and Hay) n. comb.

Coccolithus floridanus Roth and Hay in Hay and others, 1967, Gulf Coast Assoc. Geol. Socs. Trans. 17: 455, Pl. 6, figs. 1-4.

Cyclococcolithus neogammation Bramlette and Wilcoxon, 1967, Tulane Studies Geol. 5: 104, Pl. 1, figs. 1-3; Pl. 4, figs. 3-5.

Cyclococcolithus floridanus (Roth and Hay), of Müller, 1970, Geologica Bavarica 63: 113, Pl. 2, figs. 1-3.

Cyclococcolithus floridanus (Roth and Hay), of Roth, 1970, Eclogae Geol. Helv. 63: 854, Pl. 5, fig. 6.

Remarks.—The original definition of *Coccolithus floridanus* Roth and Hay describes a small (3.6 to 5 micron) elliptic placolith. The original definition of *Cyclococcolithus neo-*

gammation Bramlette and Wilcoxon describes a medium sized (6 to 12 micron) circular placolith. According to Roth (1970) the electronmicrograph paratypes of these two species show the same construction and number of rim elements. The slight difference in size and shape noted in the written descriptions probably resulted from the description of end members of the same species and from the use of different instrumentation.

Cyclicargolithus luminis (Sullivan) n. comb.

Cyclococcolithus luminis Sullivan, 1965, Univ. Calif. Publ. Geol. Sci. 53: 33, Pl. 3, figs. 9a, b.

Cyclicargolithus reticulatus (Gartner and Smith) n. comb.

Cyclococcolithus reticulatus Gartner and Smith, 1967, Univ. Kansas Paleont. Contr., Paper 20, p. 4, Pl. 5, figs. 1-4.

Genus *Cyclolithella* Loeblich and Tappan, 1963

***Cyclolithella kariana* n. sp.**

Pl. 3, figs. 4-5

Description.—This small circular coccolith has a small circular central opening that occupies about a quarter to a third of the diameter. The thick upper shield is composed of about 12 to 20 curving crystallites that are strongly imbricated, indicated by the spiralling effect as focus is raised or lowered through the coccolith. The margin of the central opening and outer perimeter is generally smooth, but the perimeters of a few etched(?) specimens appear slightly scalloped. In cross-polarized light, no sharp black extinction bands are seen; instead, four light-gray rays each occupy two or three crystallites.

Remarks.—*Cyclolithella kariana* is distinguished from other species of *Cyclolithella* by the small central opening. It is further distinguished from the most similar species, *Cyclolithella pactilis* Bukry and Percival, by curved, gray extinction bands instead of straight black ones, when viewed in cross-polarized light.

Occurrence.—*Cyclolithella kariana* occurs commonly in lower Eocene sediment assigned to the *Discoaster lodoensis* Zone at DSDP 47.2 on the Shatsky Rise of the northwestern Pacific Ocean.

Size.—6 to 9 microns.

Holotype.—USNM 176893 (Pl. 3, figs. 4-5).

Type locality.—DSDP 47.2-7-3, 104-105 cm, Shatsky Rise, northwestern Pacific Ocean.

Genus *Discoaster* Tan, 1927

***Discoaster bifax* n. sp.**

Pl. 3, figs. 6-11

Description.—This small species is constructed of 10 to 15 (typically 14) approximately radial rays that are appressed and terminate in broad points. High central stems extend from each side of the discoaster. The stem on one side is slender, occupying only 25 percent of the shield diameter, whereas the stem on the other side is consistently twice as wide, occupying 50 percent of the shield diameter. No birefringence is seen in cross-polarized light.

Remarks.—*Discoaster bifax* is distinguished from other compact discoasters, *Discoaster barbadiensis* Tan, *D. circularis* Hoffmann, *D. multiradiatus* Bramlette and Riedel, *D. saipanensis* Bramlette and Riedel, and *D. salisburgensis* Stradner, by tall central stems

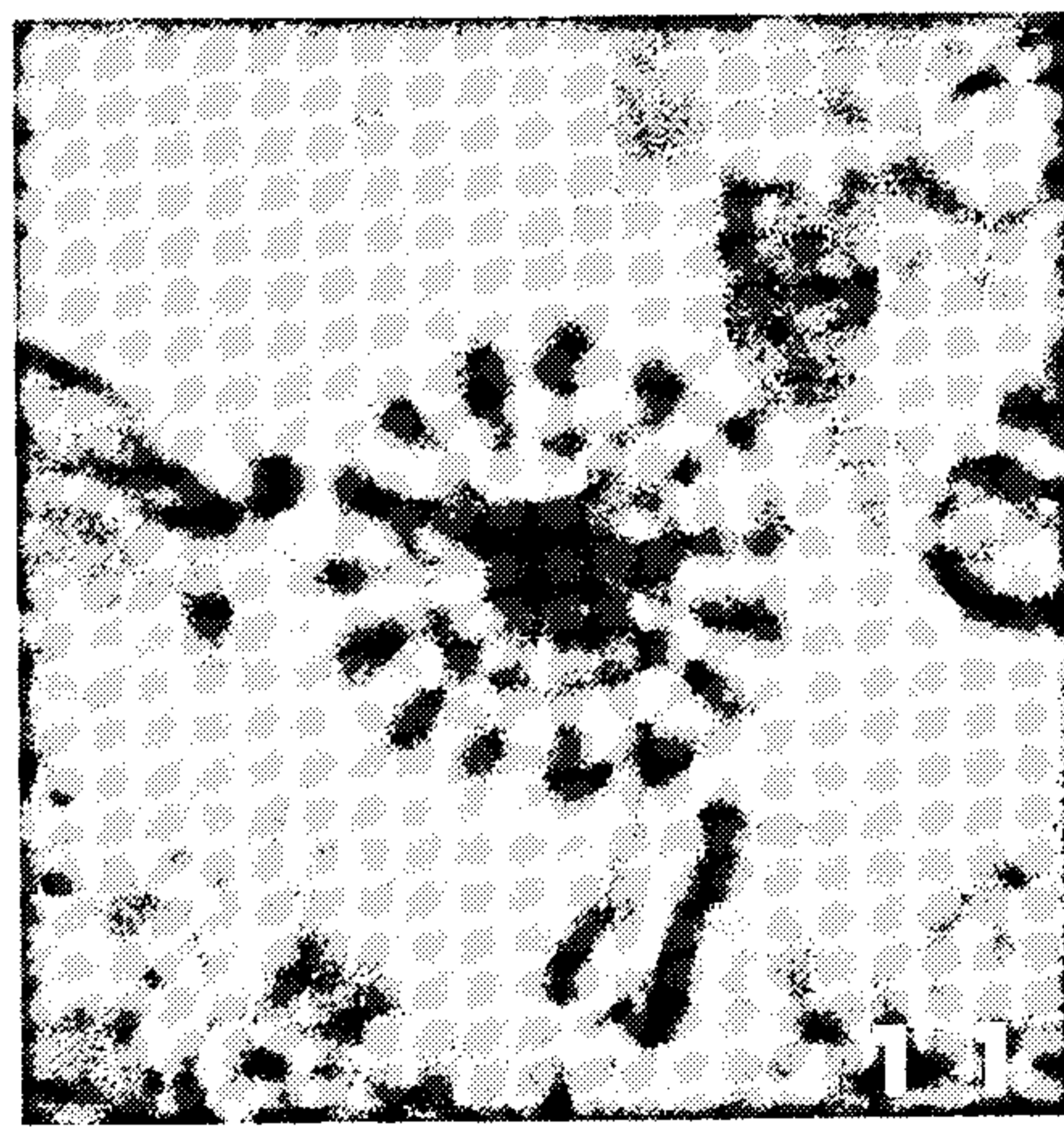
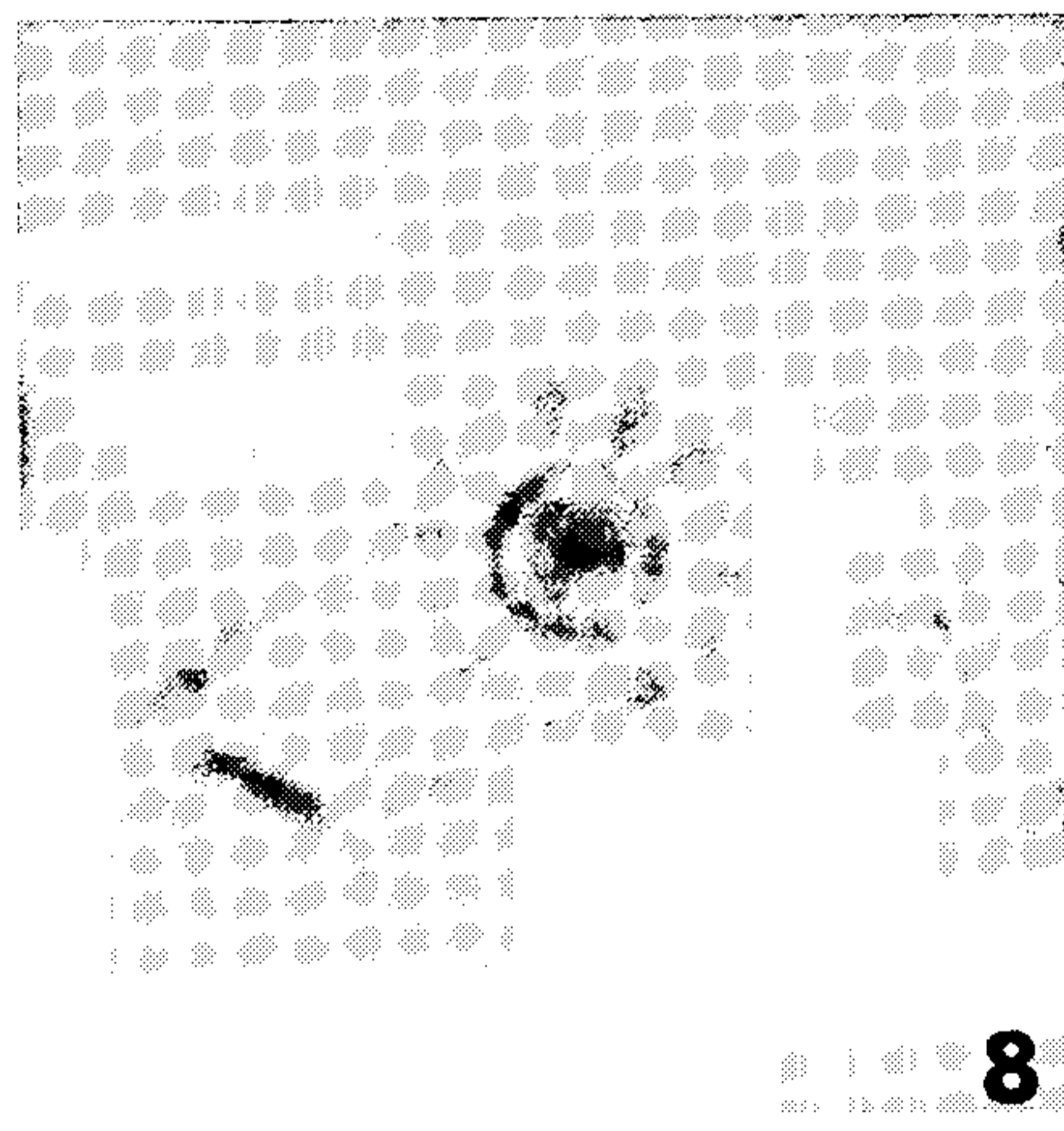
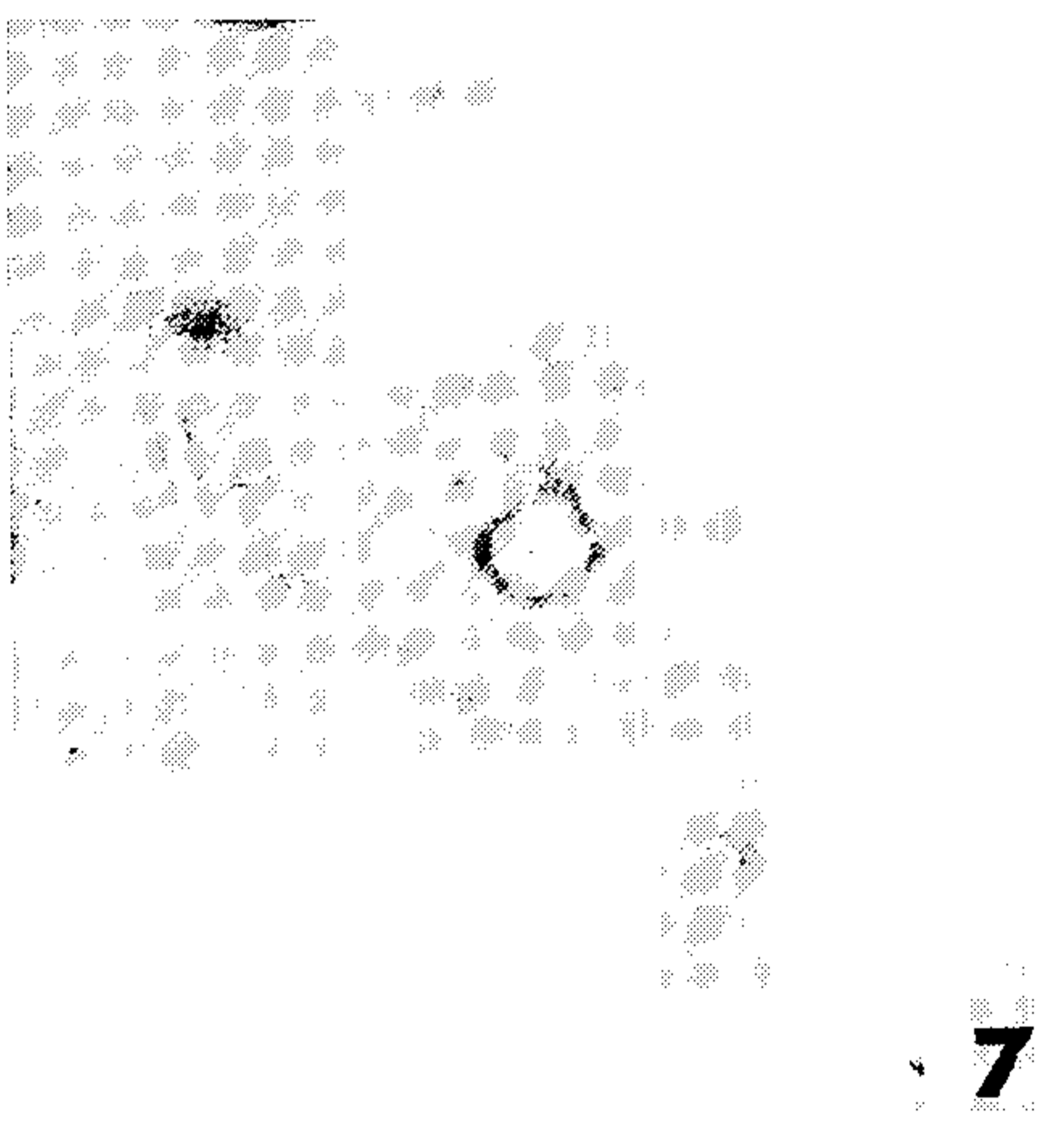
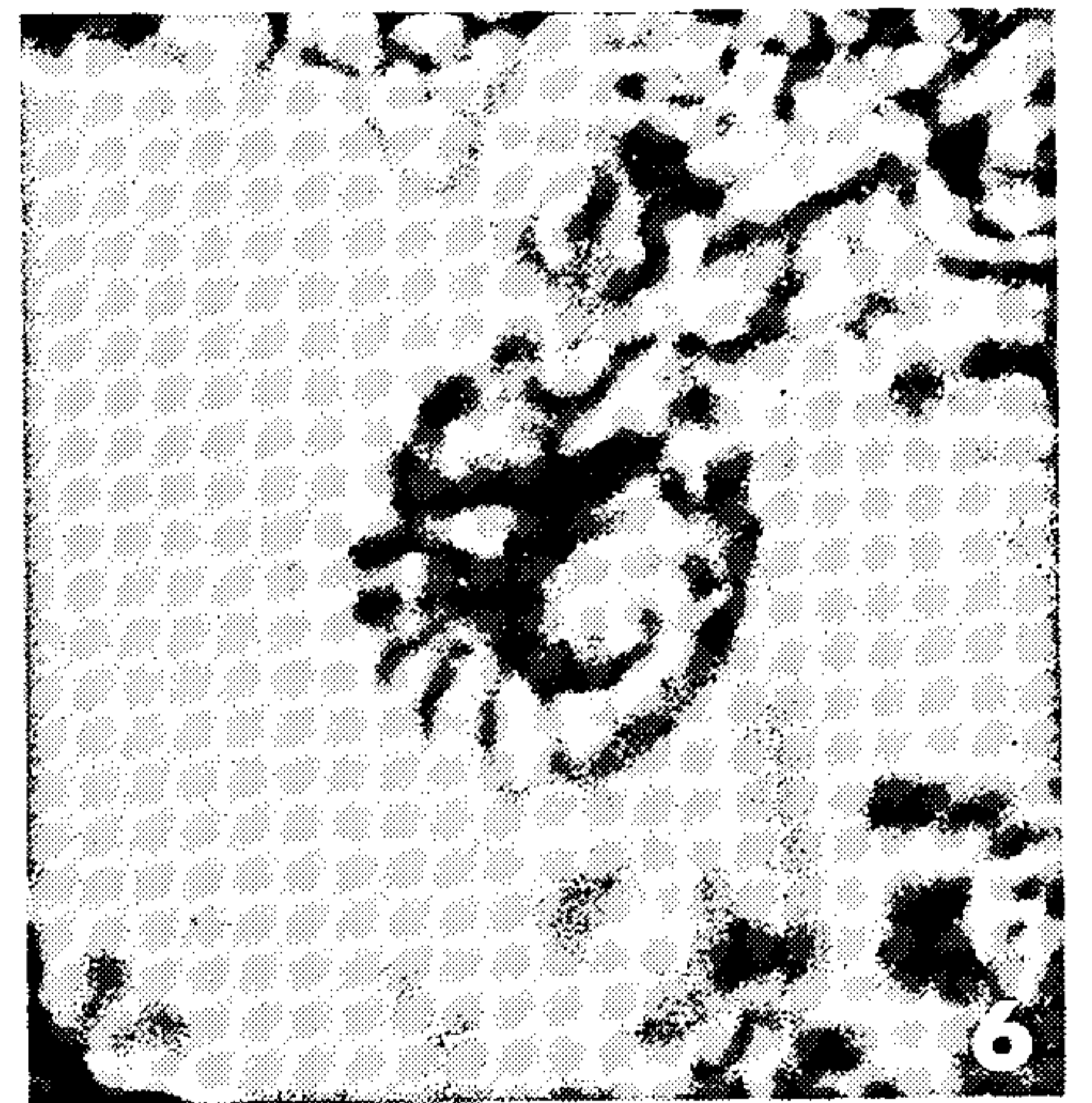
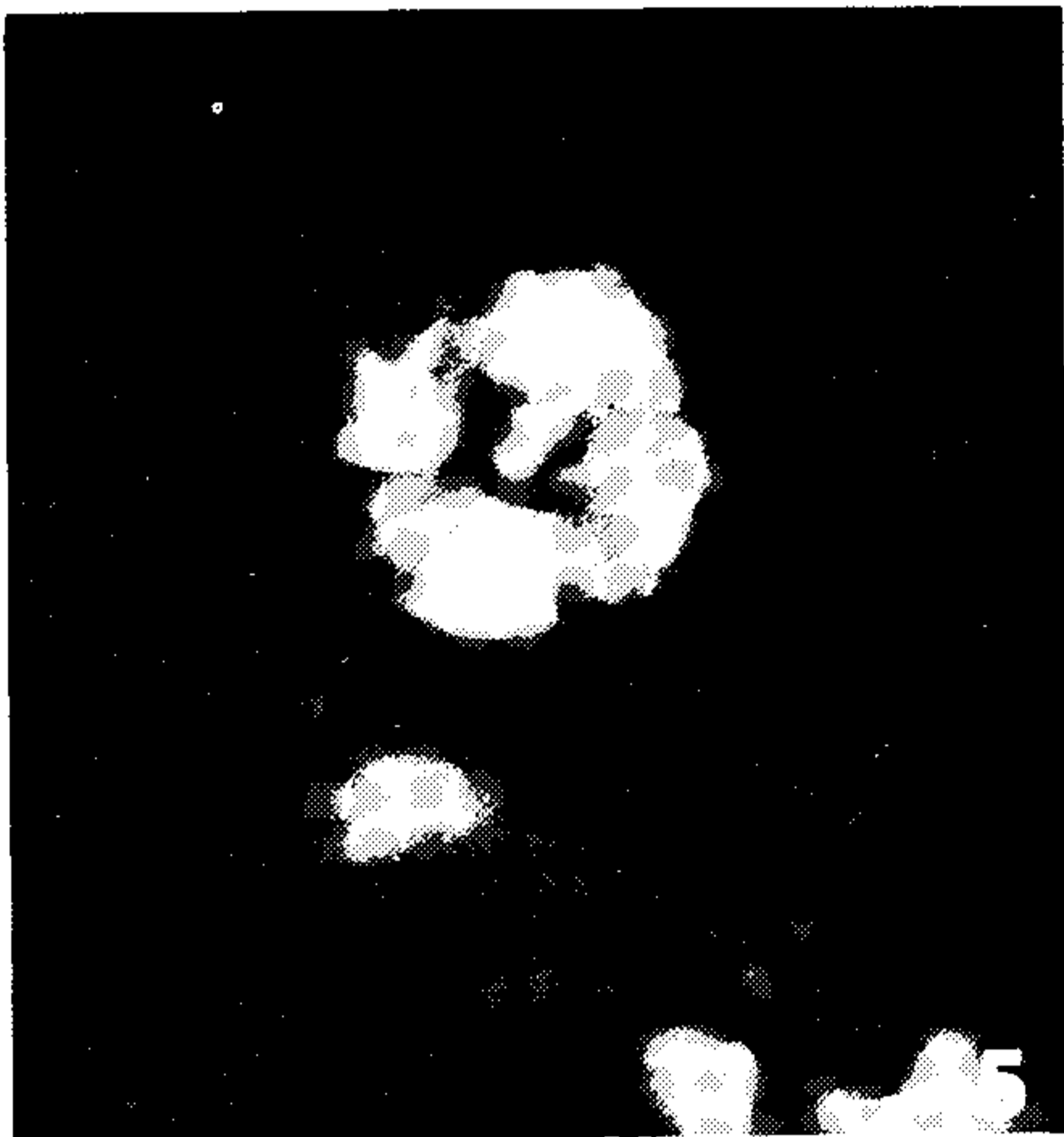
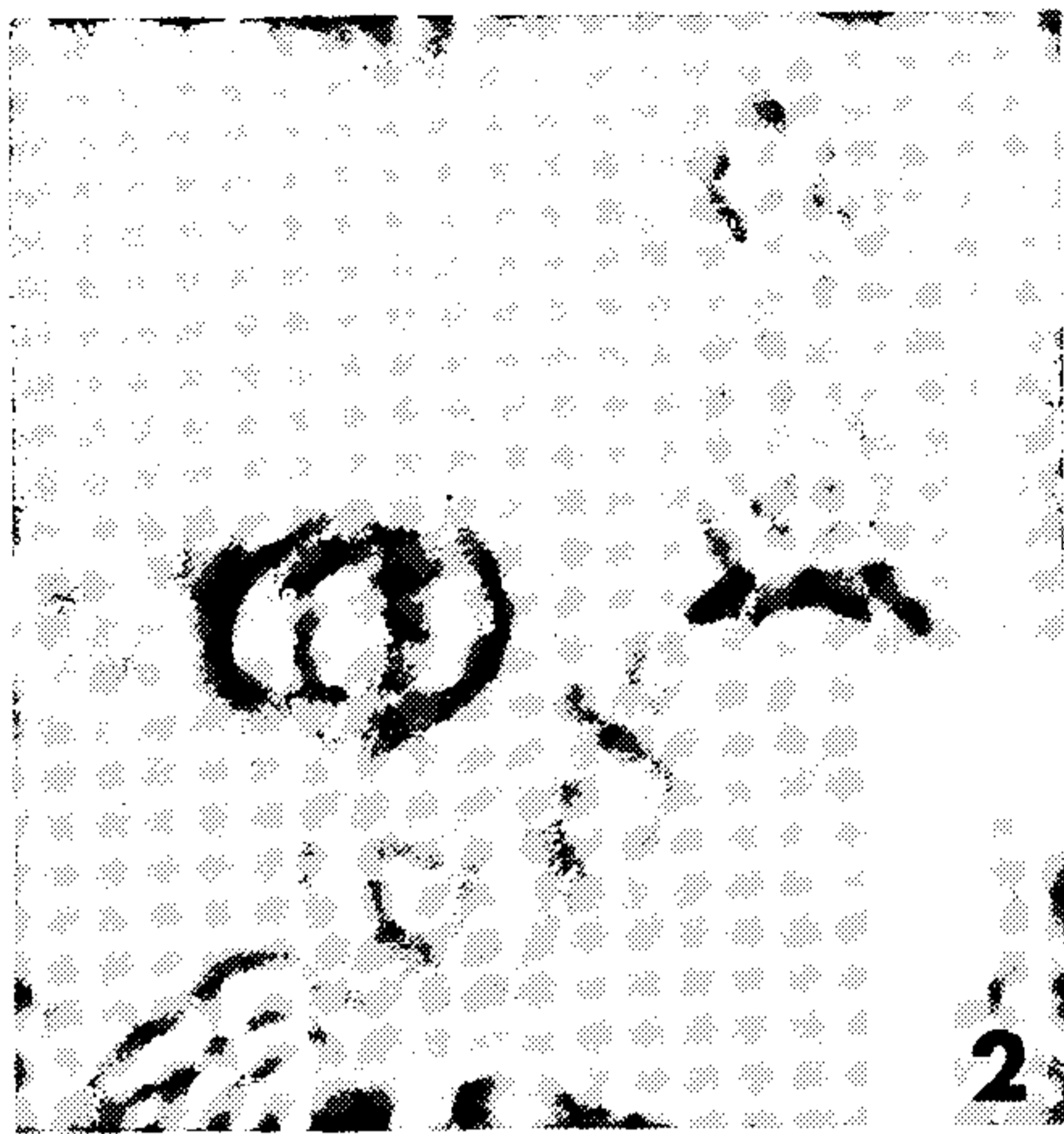

THIS PAGE IS LOCKED TO FREE MEMBERS
Purchase full membership to immediately unlock this page

DELVE INTO FANTASY, MAGIC, MYTHOLOGY & FOLKLORE

Forgotten Books'
Full Membership gives
access to 797,885 ancient
and modern, fiction and
non-fiction books.

Continue

*Fair usage policy applies

Description.—This small- to medium-sized, six-rayed species has a central area occupying about a third of the total discoaster diameter. It has a small central knob, and the rays are distinctly tapered, being widest near the central area. The tips of the rays have distinctive unequal bifurcations that are bent slightly out of the plane of the rays. Both limbs of the bifurcation taper to points, but all six sets show one limb that is consistently more than twice as long as the other. The sense of direction of the resulting asymmetric bifurcation is always the same for all six rays of a given specimen.

Remarks.—Besides *Discoaster loeblichii*, the only other six-rayed discoaster with ordered, therefore primary, crescent-forming bifurcations is *Discoaster calcaris* Gartner, which is a large form more comparable in size, proportions, and occurrence to five-rayed *D. hamatus* Martini and Bramlette. *Discoaster loeblichii* is distinguished by a proportionally larger central area, by shorter, broader, and more tapering rays, and by a smaller average size (12 to 16 microns instead of 16 to 22 microns). It appears to have been derived from the *Discoaster variabilis* group, and differs from *D. variabilis variabilis* Martini and Bramlette by the unequal bifurcations that form an asymmetric crescent at the ray tips.

Occurrence.—*Discoaster loeblichii* was a limited stratigraphic range in the early late Miocene *Discoaster neohamatus* Zone, where it is most common in the middle to upper part of that zone. Geographically, *D. loeblichii* is known from the tropical Pacific Ocean areas cored during Deep Sea Drilling Project Legs 7 to 9.

Size.—11 to 16 microns.

Holotype.—USNM 176902 (Pl. 4, fig. 4).

Paratype.—USNM 176901, 176903.

Type locality.—DSDP 83A-15-6, 130-131 cm, Panama Basin, eastern equatorial Pacific Ocean.

***Discoaster neorectus* n. sp.**

Pl. 4, figs. 6-7

Description.—This gigantic six-rayed species has a small central stem but no separately marked central area. The rays are long and symmetrically arranged, with sides that are straight or slightly convex. The rays have a slight taper and terminate in simple sharp points.

Remarks.—*Discoaster neorectus* has simple, pointed terminations that distinguish it from *Discoaster brouweri brouweri* Tan, emended, which has rays bent like umbrella ribs, and *D. brouweri rutellus* Gartner, which has blade-like wedges at the end of each ray. *Discoaster neorectus* is distinguished from *D. intercalaris* by the narrower taper of the rays and by the lack of a significant central area.

Occurrence.—In nannofossil assemblages from the Pacific Ocean, *Discoaster neorectus* is common in only a limited stratigraphic horizon of the upper Miocene, upper *Discoaster neohamatus* Zone to lower *Discoaster quinquerramus* Zone. The unusually large size of this species makes it a convenient guide. Slightly less robust specimens than those of the Pacific, but equally large, are common in Core DSDP 3-10 from the Gulf of Mexico.

Size.—20 to 38 microns.

Plate 4. Photomicrographs: 2,000 X, unless noted otherwise. 1-2. *Discoaster intercalaris* n. sp. (1) holotype USNM 176899, DSDP 36-12-5, 77-78 cm, (2) USNM 176900. 3-5. *Discoaster loeblichii* n. sp. (3) USNM 176901, DSDP 83A-16-4, 64-65 cm, (4) holotype USNM 176902, DSDP 83A-15-6, 130-131 cm, (5) USNM 176903, DSDP 83A-16-4, 64-65 cm. 6-7. *Discoaster neorectus* n. sp. (6) USNM 176904, DSDP 72.0-3-4, 63-64 cm, magnification 1,000 X, (7) holotype USNM 176905. 8-9. *Fasciculithus clinatus* n. sp. (8) holotype USNM 176906, DSDP 47.2-9-5, 77-78 cm, (9) holotype, cross-polarized.

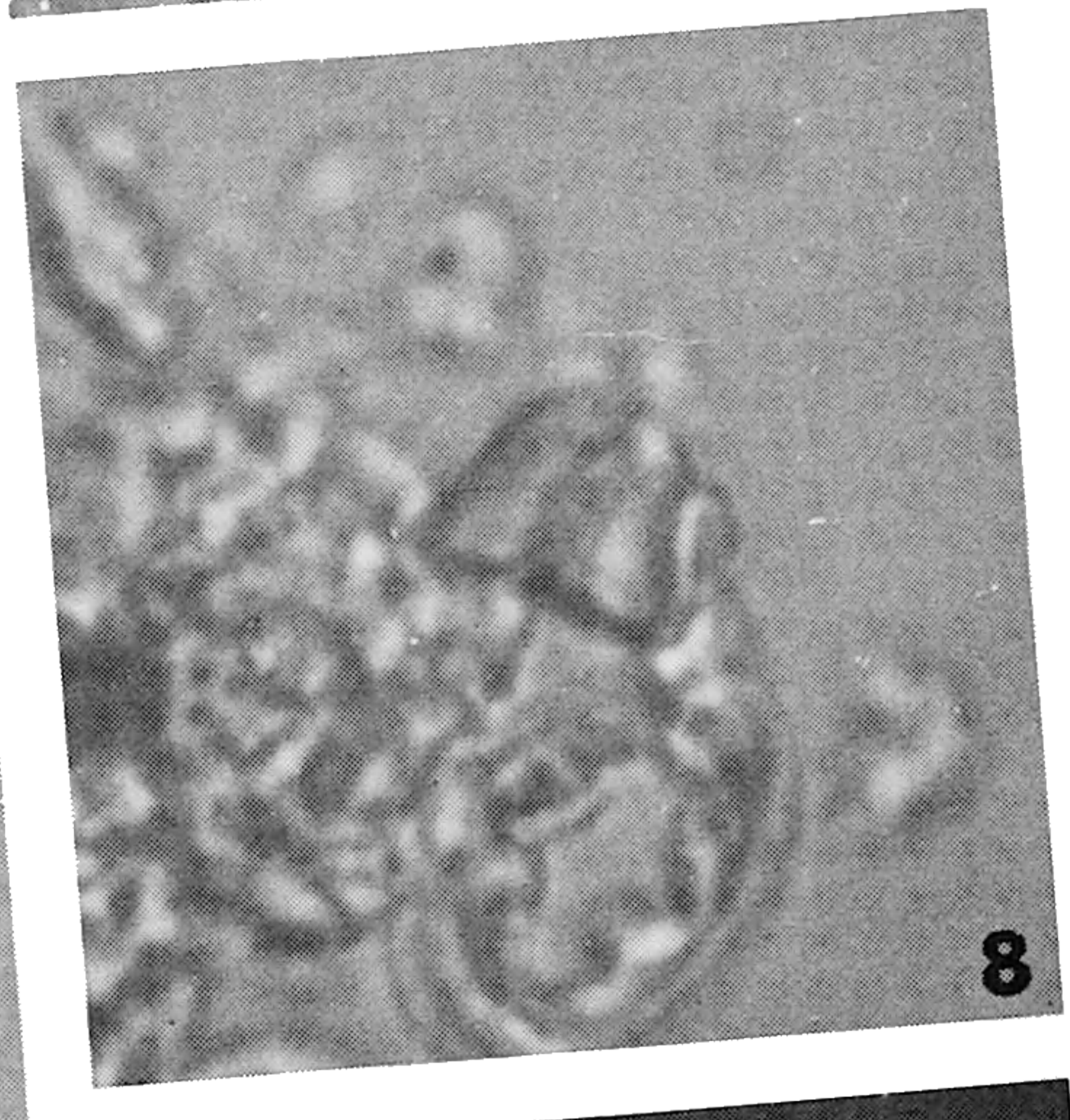
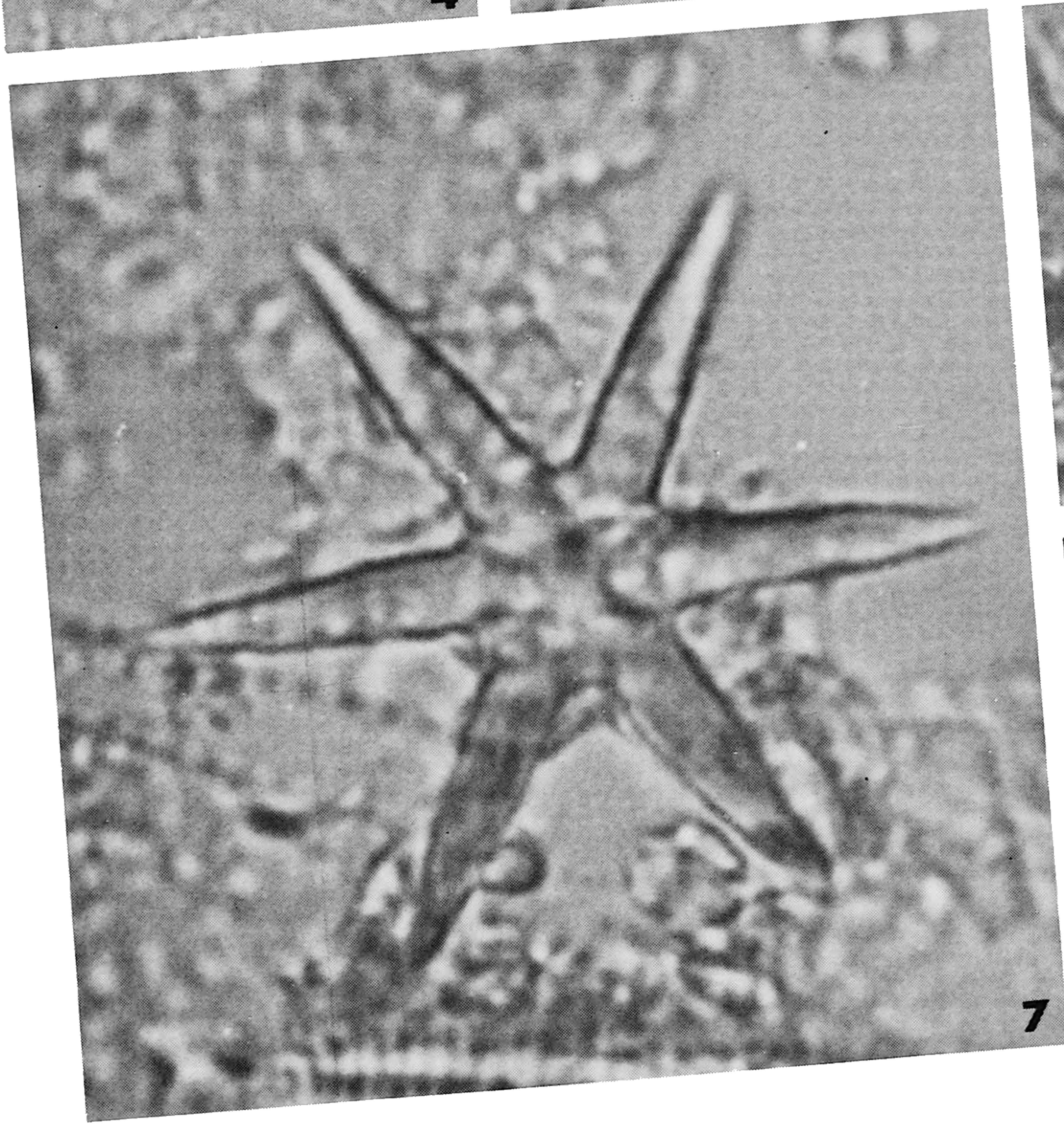
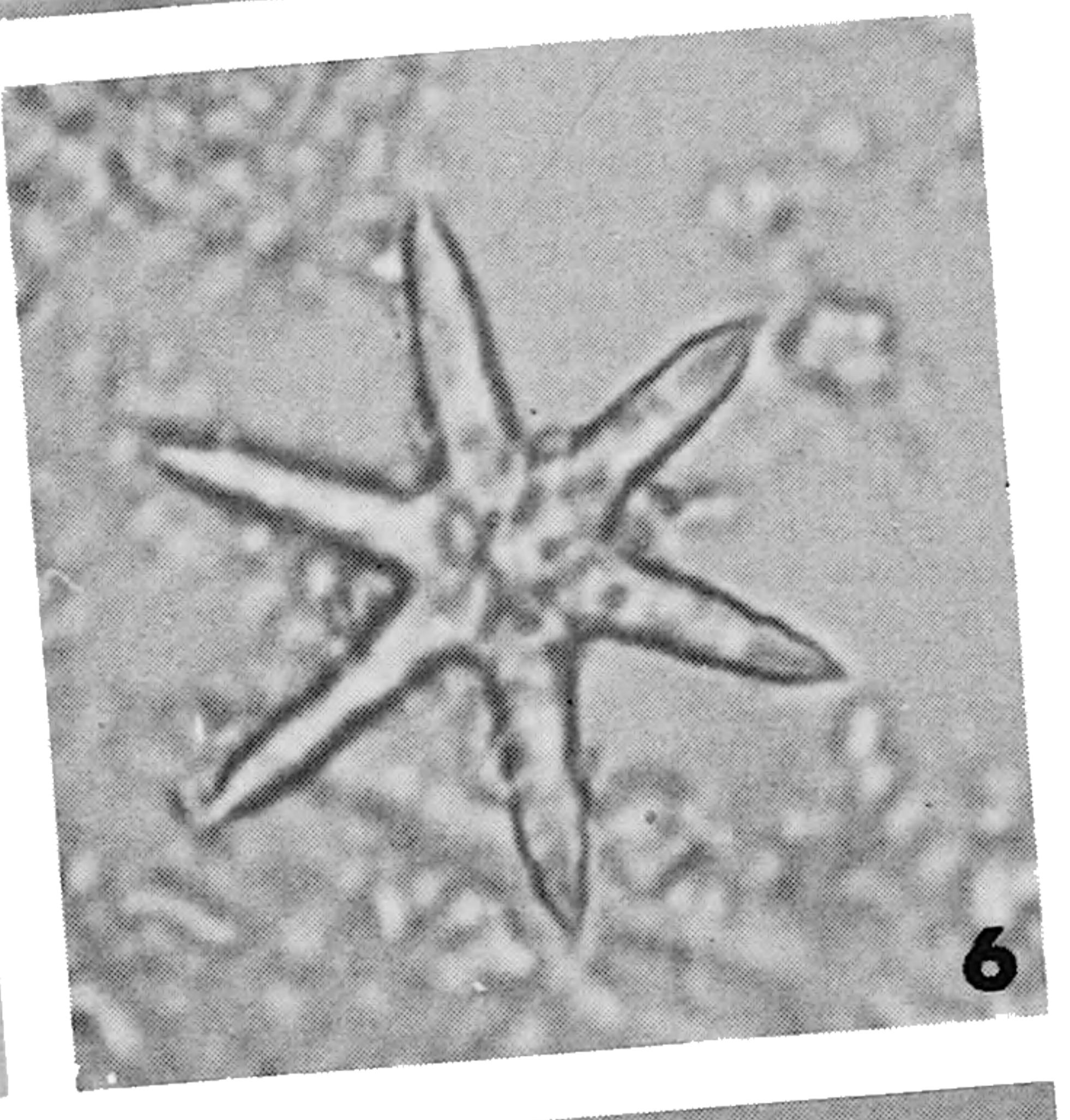
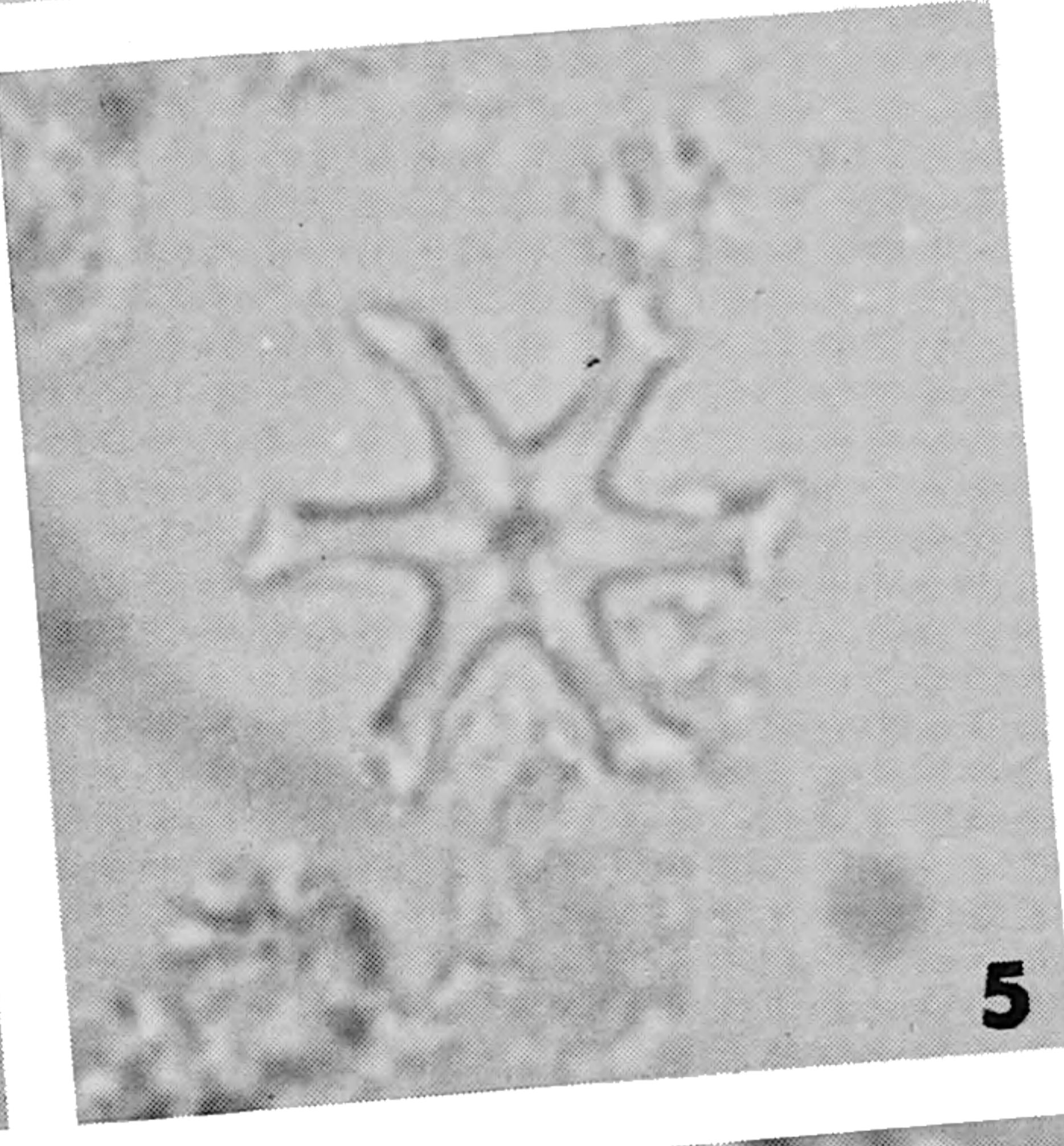
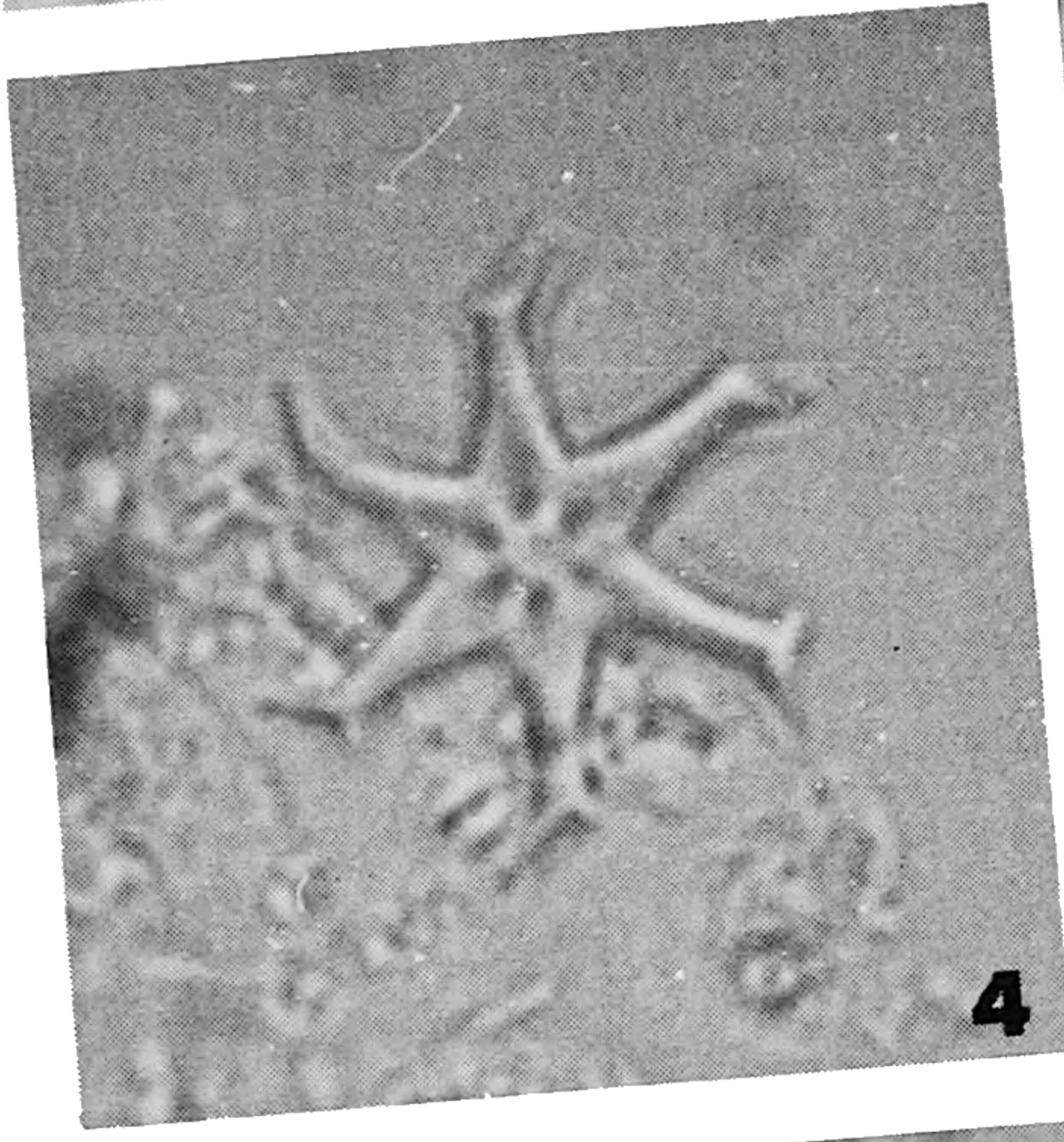
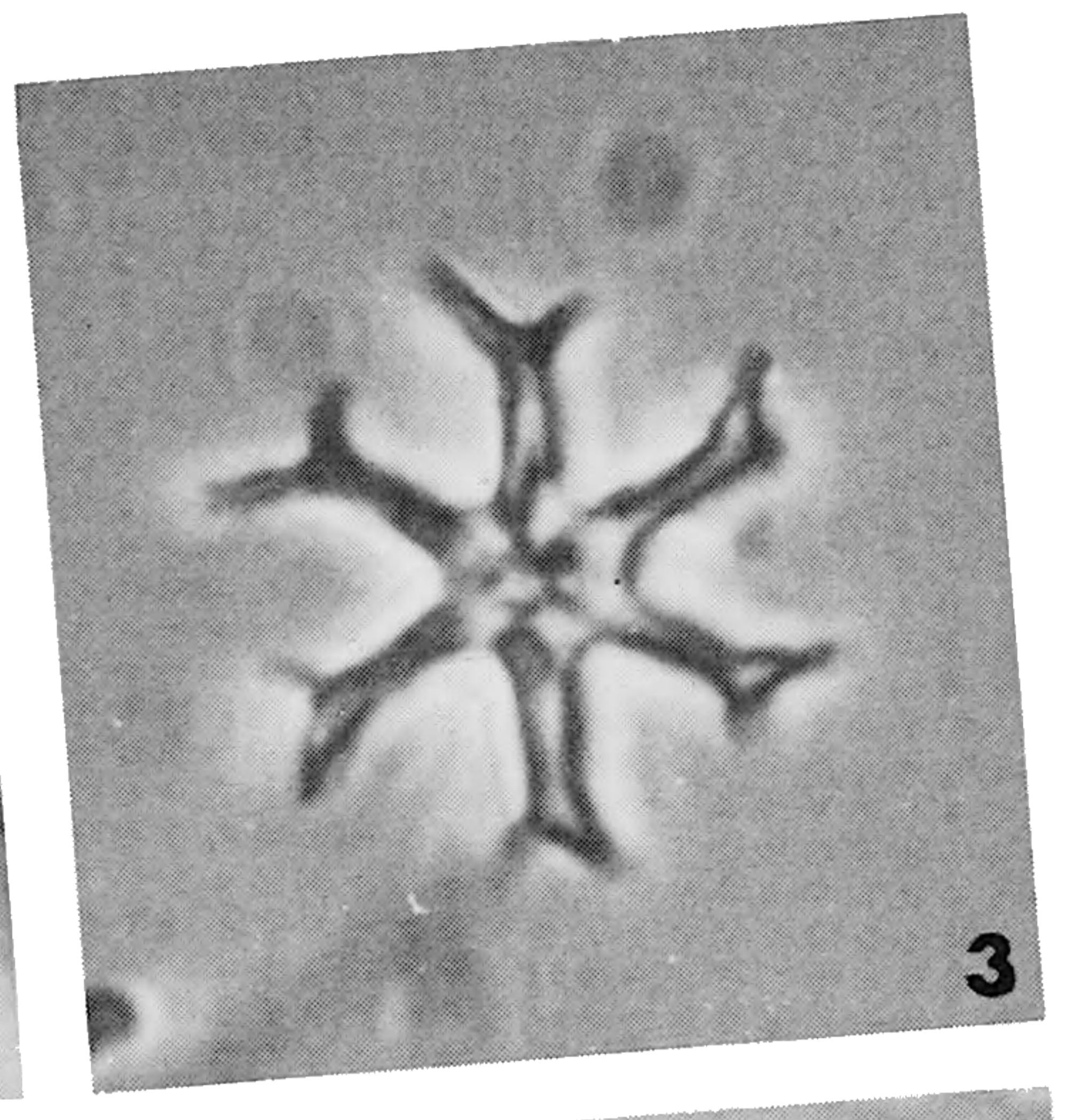
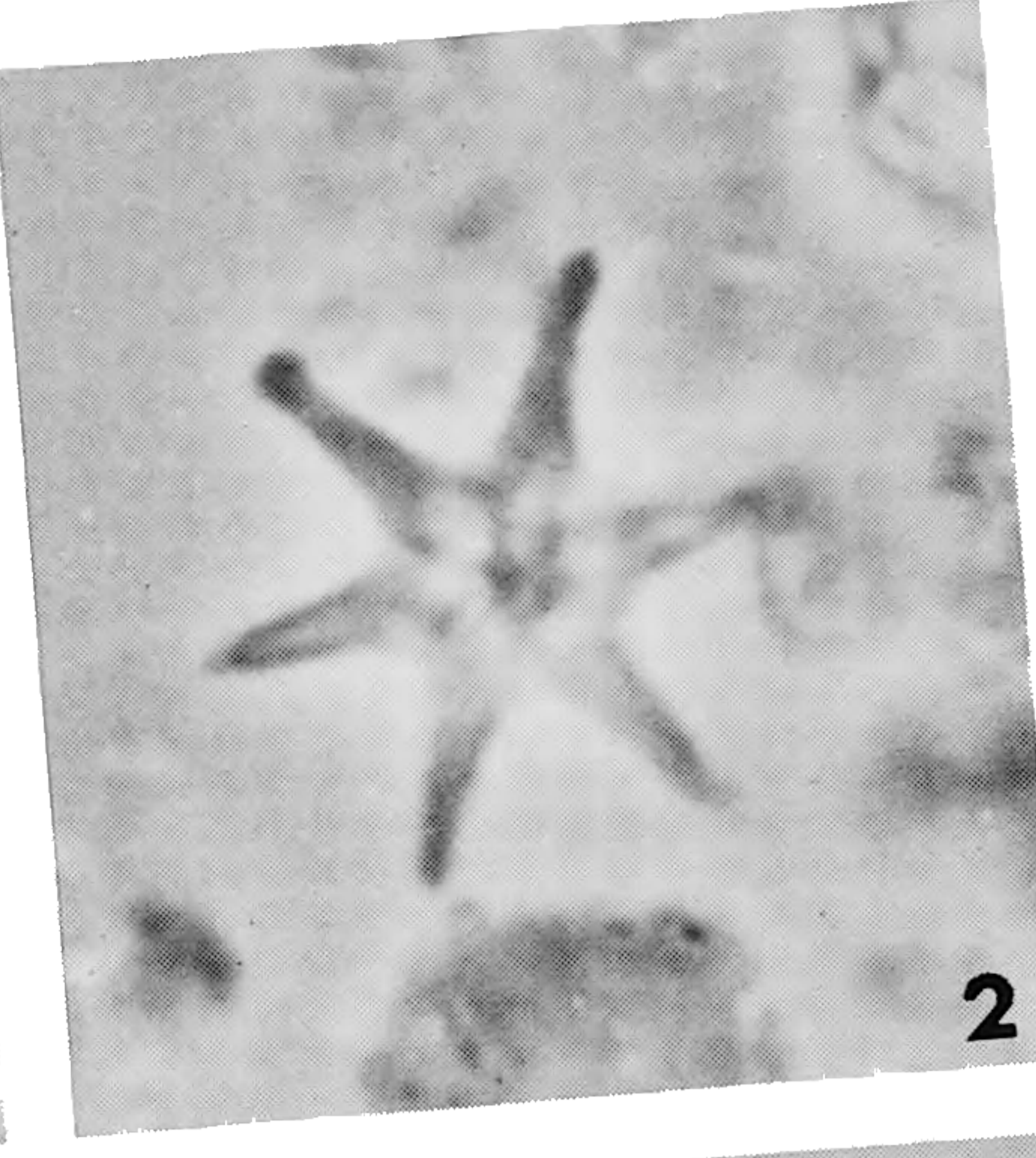
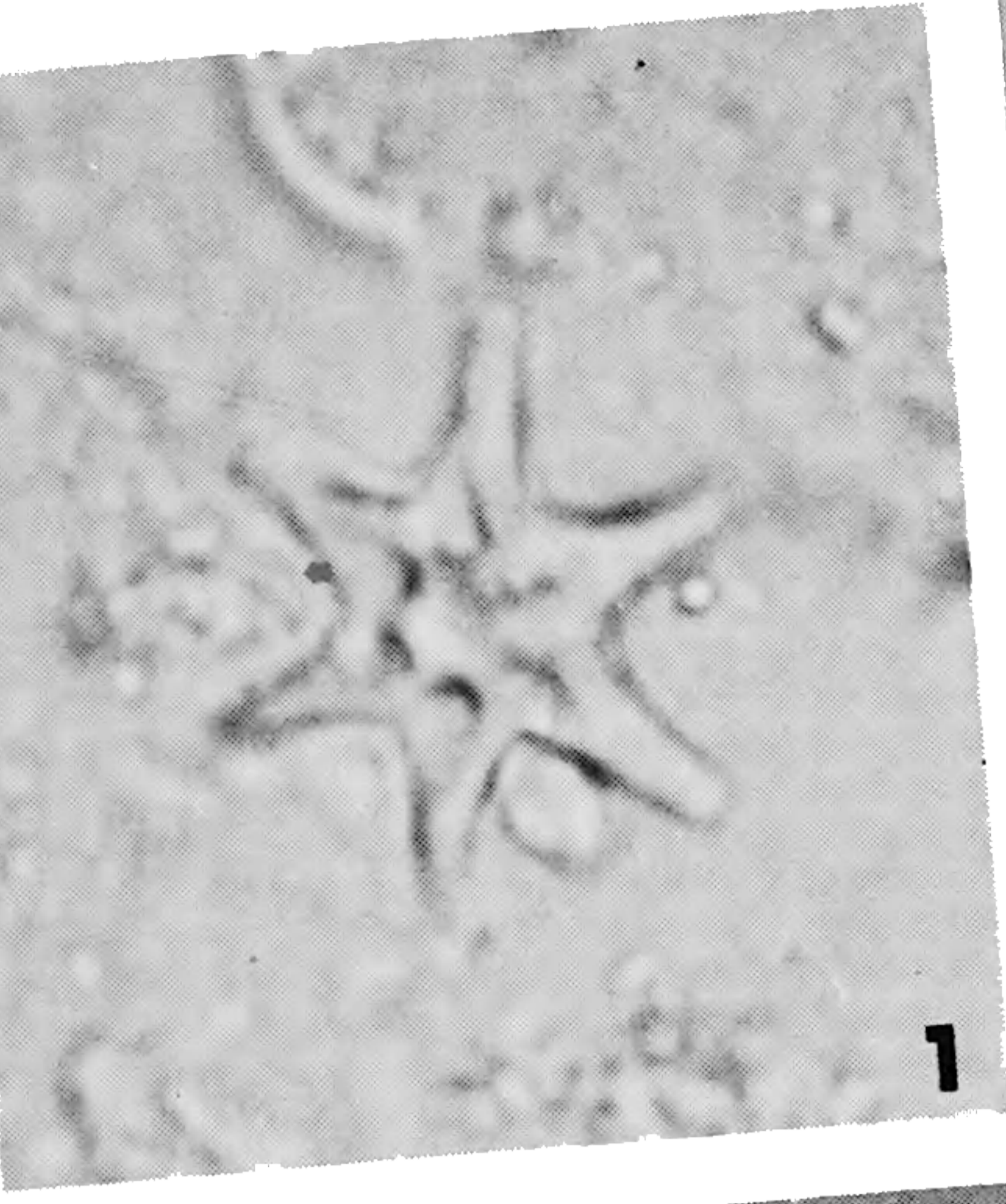

Holotype.—USNM 176905 (Pl. 4, fig. 7).

Paratype.—USNM 176904.

Type locality.—DSDP 72.0-3-4, 63-64 cm, western flank East Pacific Rise, equatorial Pacific Ocean.

Genus *Fasciculithus* Bramlette and Sullivan, 1961

***Fasciculithus clinatus* n. sp.**

Pl. 4, figs. 8-9

Description.—This small simple species has a short conical form with a slightly rounded top that produces an almost triangular outline in side view. The base line is essentially straight in side view and is slightly longer than the upper sides, which are straight to slightly convex. In cross-polarized light, a single median extinction band bisects the triangular outline.

Remarks.—*Fasciculithus clinatus* is distinguished from other species of *Fasciculithus* by its small size and almost triangular outline. The only comparable small form, *F. tympaniformis* Hay and Mohler, is cylindrical, with parallel instead of inclined sides. *Fasciculithus magnus* Bukry and Percival may have inclined sides for only half of its height and is much larger than *F. clinatus*. Also, *F. clinatus* lacks the pit-and-ridge ornamentation developed in several other species, such as *F. involutus* Bramlette and Sullivan.

Occurrence.—*Fasciculithus clinatus* is common in upper Paleocene sediment of the Shatsky Rise in the northwestern Pacific Ocean.

Size.—height, 4 to 6 microns.

Holotype.—USNM 176906 (Pl. 4, figs. 8-9).

Type locality.—DSDP 47.2-9-5, 77-78 cm, Shatsky Rise, northwestern Pacific Ocean.

Genus *Helicopontosphaera* Hay and Mohler, 1967

***Helicopontosphaera heezenii* n. sp.**

Pl. 5, figs. 1-5

Description.—This large species has a long bar, aligned with the long axis of the nanofossil, that dominates the central area. The length of the bar is 53 to 61 percent of the total nanofossil length. The bar is rounded at the ends, and although the sides are normally smooth, some etched specimens show irregularities suggesting small perforations. In cross-polarized light, the central bar is brightest when aligned with a polarization direction.

Remarks.—*Helicopontosphaera heezenii* is distinguished from similar forms such as *Helicopontosphaera lophota* (Bramlette and Sullivan) and *H. papillata* Bukry and Bramlette by the greater length and the axial alignment of the central bar. It is distinguished from *H. reticulata* (Bramlette and Wilcoxon) by its non-rhomboid shape and non-diagonal central bar.

Occurrence.—*Helicopontosphaera heezenii* is common in the upper middle Eocene at DSDP 44 on Horizon Ridge in the northwestern Pacific Ocean, where it was first recognized. It also occurs in coeval sediment of Stetson 21, northwestern Atlantic Ocean.

Plate 5. Photomicrographs: 2,000 X. 1-5. *Helicopontosphaera heezenii* n. sp. (1) USNM 176907, DSDP 44.0-4-6, 145-150 cm, 45°, (2) holotype USNM 176908, 45°, (3) holotype, cross-polarized, 0°, (4) USNM 176909, 45°, (5) same as figure 1, cross-polarized 90°. 6-9 *Helicopontosphaera rhomba* n. sp. (6) USNM 176910, DSDP 54.0-2-1, 67-68 cm, 45°, (7) holotype USNM 176911, DSDP 54.0-2-4, 81-82 cm, 45°, (8) holotype, cross-polarized, 90°, (9) same as figure 6, cross-polarized, 90°. 10-12. *Sphenolithus conicus* n. sp. (10) holotype USNM 176912, DSDP 80-5-2, 63-64 cm, 90°, (11) holotype, cross-polarized, 90°, (12) holotype, cross-polarized, 45°.

THIS PAGE IS LOCKED TO FREE MEMBERS
Purchase full membership to immediately unlock this page

FORGOTTEN BOOKS

FULL MEMBERSHIP

797,885 Books!
All you can read
for only
\$8.99/month

Continue

*Fair usage policy applies



Size.—13 to 18 microns.

Holotype.—USNM 176908 (Pl. 5, figs. 2-3).

Paratypes.—USNM 176907, 176909.

Type locality.—DSDP 44.0-4-6, 145-150 cm, Horizon Ridge, northwestern Pacific Ocean.

***Helicopontosphaera rhomba* n. sp.**

Pl. 5, figs. 6-9

Description.—This large species has a large elongate central opening that is bridged by a diagonal bar oriented at about 45° to the long axis of the nannofossil. In cross-polarized light, the diagonal bar is bright when the long axis of the nannofossil is aligned with a polarization direction, but it is dark at 45° . The short-axis extinction bands are broad and diffuse when the nannofossil is at 90° . The bar is not in optical continuity with the rim.

Remarks.—*Helicopontosphaera rhomba* is distinguished from *Helicopontosphaera lophota* (Bramlette and Wilcoxon) by its more elongate shape, larger central opening, and more diffuse short-axis extinction bands. It is distinguished from *H. intermedia* (Martini) by its larger, non-sigmoid bar; from *H. parallela* (Bramlette and Wilcoxon) by its more open central area and diagonally aligned bar; and from *H. bramlettei* Müller (= *H. wilcoxonii* Gartner) by its more elongate outline and diagonal (approx. 45°) bar.

Occurrence.—*Helicopontosphaera rhomba* is presently known only from the Philippine Sea in lower middle Miocene deposits cored during DSDP Leg 6.

Size.—15 to 18 microns.

Holotype.—USNM 176911 (Pl. 5, figs. 7-8).

Paratypes.—USNM 176910.

Type locality.—DSDP 54.0-2.4, 81-82 cm, Philippine Sea.

Genus *Sphenolithus* Deflandre, 1952

***Sphenolithus conicus* n. sp.**

Pl. 5, figs. 10-12

Description.—This large species is characterized by its tall triangular outline in side view. The several apical spines are partly coalesced to form the triangular to rounded triangular upper section of the nannofossil. In cross-polarized light, the base is divided into quadrants by the extinction bands when the long axis of the nannofossil is aligned with a polarization direction. The height of the lower quadrants is equal to or slightly greater than the upper quadrants. The apical complex is bright when oriented at 45° to the polarization directions.

Remarks.—*Sphenolithus conicus* could be mistakenly identified as a large *Sphenolithus heteromorphus* Deflandre but is distinguished by the greater proportion of the fossil that is formed by the basal quadrants instead of by the apical complex. It is distinguished from *S. moriformis* (Brönnimann and Stradner) by its triangular instead of hemispheric outline.

Occurrence.—*Sphenolithus conicus* occurs in lower lower Miocene sediment of the lower *Triquetrorhabdulus carinatus* Zone from the Pacific Ocean.

Size.—7 to 12 microns.

Holotype.—USNM 176912 (Pl. 5, figs. 10-12).

Type locality.—DSDP 80-5-2, 63-65 cm, East Pacific Rise, eastern equatorial Pacific Ocean.

Sphenolithus obtusus n. sp.

Pl. 6, figs. 1-9

Description.—This species has a short cycle of small basal spines and a large tapering apical spine constructed of two vertically matched halves. The apical spine halves are flush and terminate together. Seen in side view and cross-polarized light, the contact between the two spine crystallites is planar, because (1) a black median line appears when the median plane of the spine is aligned to a polarization direction, (2) a solid black or white spine appears if a specimen is rolled so that the median plane is parallel to the microscope stage and thus perpendicular to the polarization directions, and (3) oblique orientations produce an off-center black line. In bright field, with a single polarizer, the apical spine is at low relief when aligned to a polarization direction, and the basal cycle is at high relief. When aligned perpendicular to a single polarization direction, the broad base of the apical spine shows a round outline. In cross-polarized light this contributes to the diagnostic obtuse angle made by the extinction line between the apical spine and the basal spine cycle. The basal cycle is short and simple. No side-oriented spines lie between the apical spine and the downward, proximally directed basal cycle.

Remarks.—*Sphenolithus obtusus* is distinguished from *S. furcatolithoides* Locker by the consistent obtuse angle formed between the apical spine and the extinction line between the basal spine in cross-polarized light. *Sphenolithus furcatolithoides* has a single straight extinction line that is perpendicular to the nannofossil axis; it also has divergent halves of the apical spine. *Sphenolithus obtusus* is distinguished from *S. distentus* (Martini) by the three-line extinction pattern of the basal spines, which are also longer than those of *S. distentus*.

In its most typical orientation on prepared slides, *S. obtusus* has the median plane of the apical spine perpendicular to the slide surface. In cross-polarized light at 15° to 25° one whole side of the nannofossil—the base and apical side—is dark. At 45°, the extinction line is missing from the apical spine; instead a light blue line is present that marks the trace of the median plane.

Occurrence.—*Sphenolithus obtusus* is common in upper middle Eocene sediment from Horizon Ridge, northwestern Pacific Ocean. *Sphenolithus furcatolithoides* occurs with *S. obtusus* only in the lower part of the range of *S. obtusus*. This distribution, together with the similarity in construction, suggest the derivation of *S. obtusus* from *S. furcatolithoides*.

Size.—6 to 12 microns.

Holotype.—USNM 176913 (Pl. 6, figs. 1-6).

Paratypes.—USNM 176914-176915.

Type locality.—DSDP 44.0-4-2, 145-150 cm, Horizon Ridge, northwestern Pacific Ocean.

Sphenolithus spiniger n. sp.

Pl. 6, figs. 10-12; Pl. 7, figs. 1-2

Description.—This small species is dominated by a basal ring of spines. In cross-polarized light, the lower basal quadrants are about twice as tall as the upper basal quadrants. The apical structure appears to be a single small spine that is bright at 45° and dark black, when oriented parallel with a polarization direction. When the nannofossil axis is oriented parallel with a polarization direction, the median extinction band is flared near the base of the specimen, giving the large lower quadrants a rounded appearance. At 45° to the polarization directions, the area occupied by the dark flare of 0° or 90° contains two bright spines that form an inverted “v” and that are outlined by black extinction

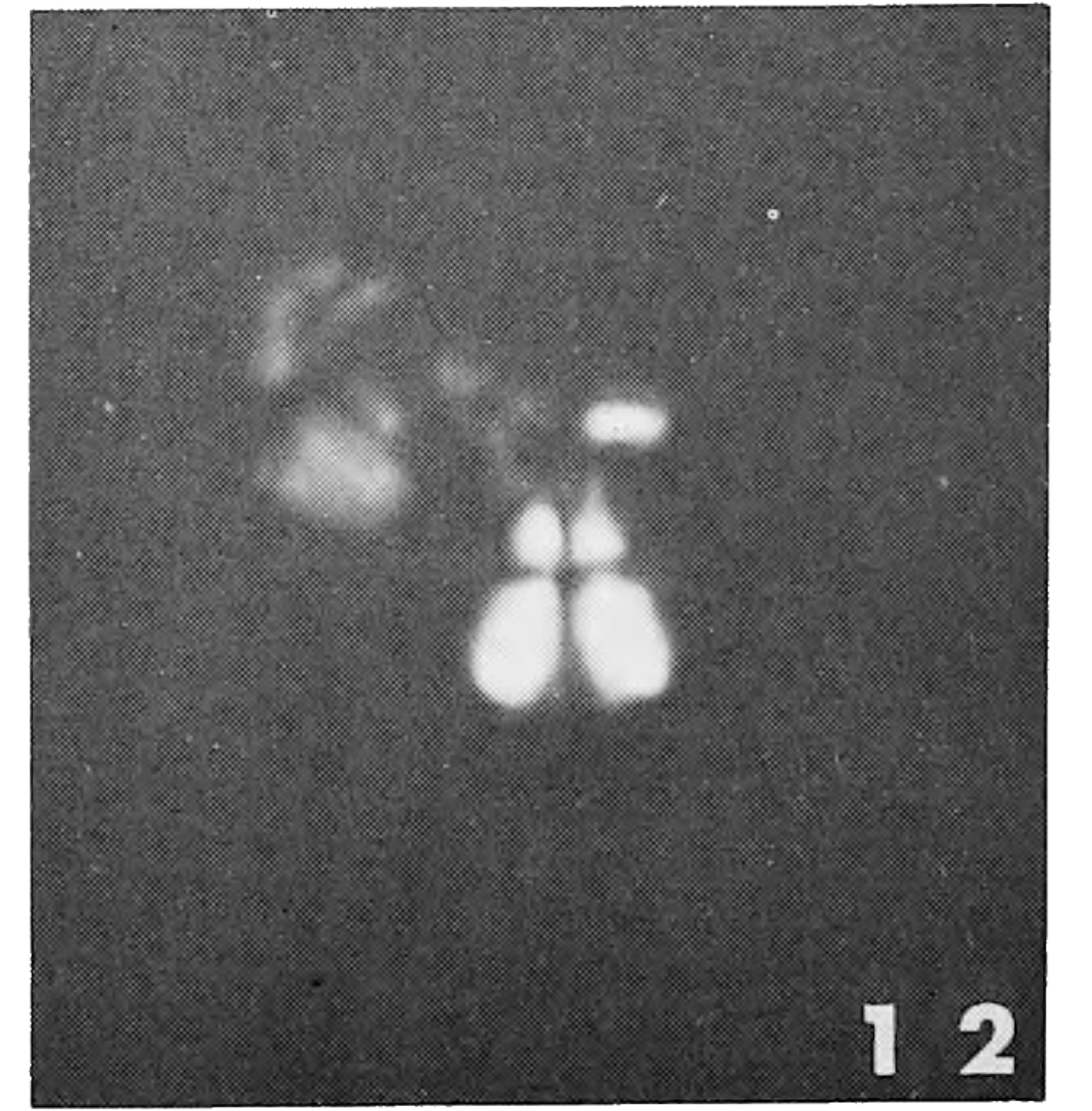
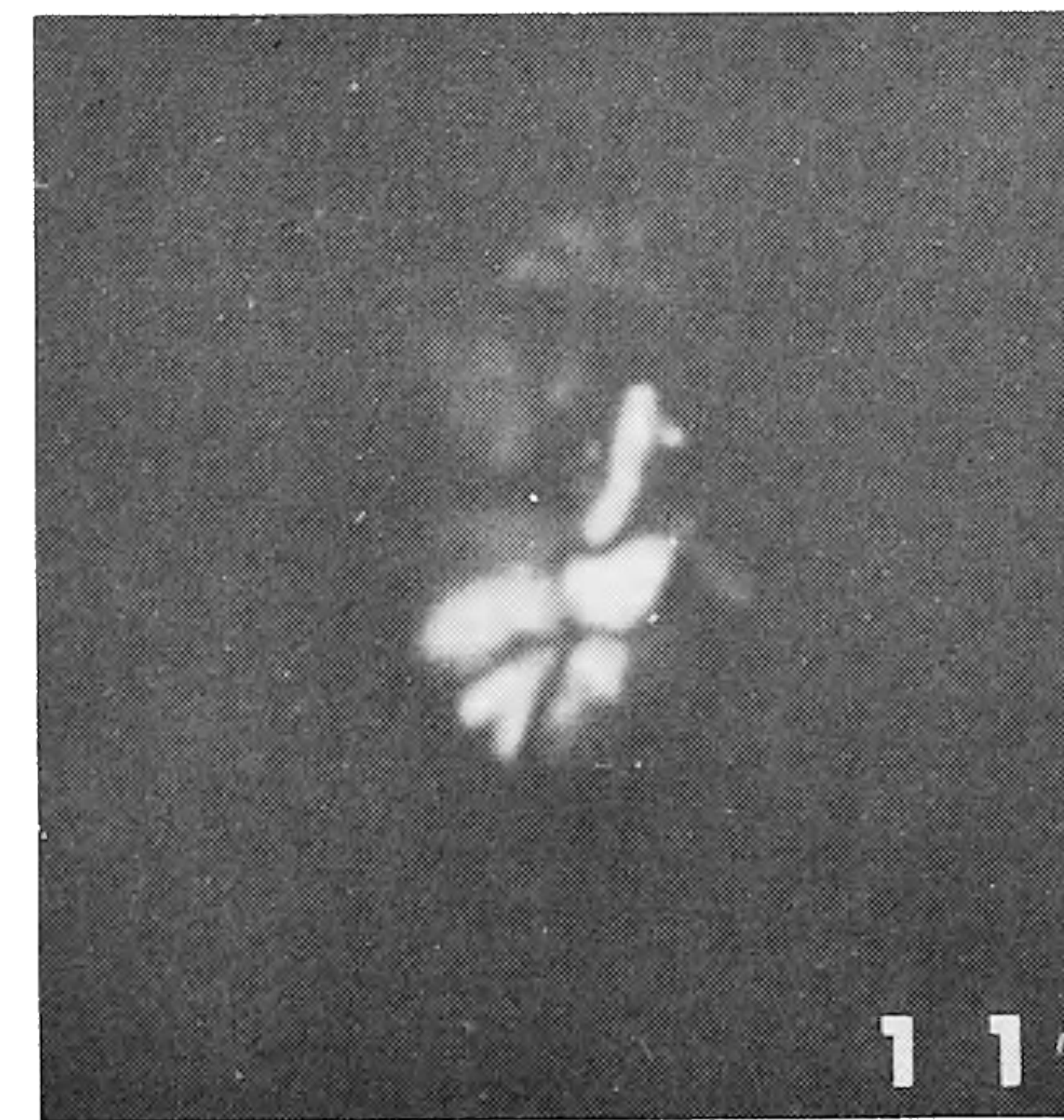
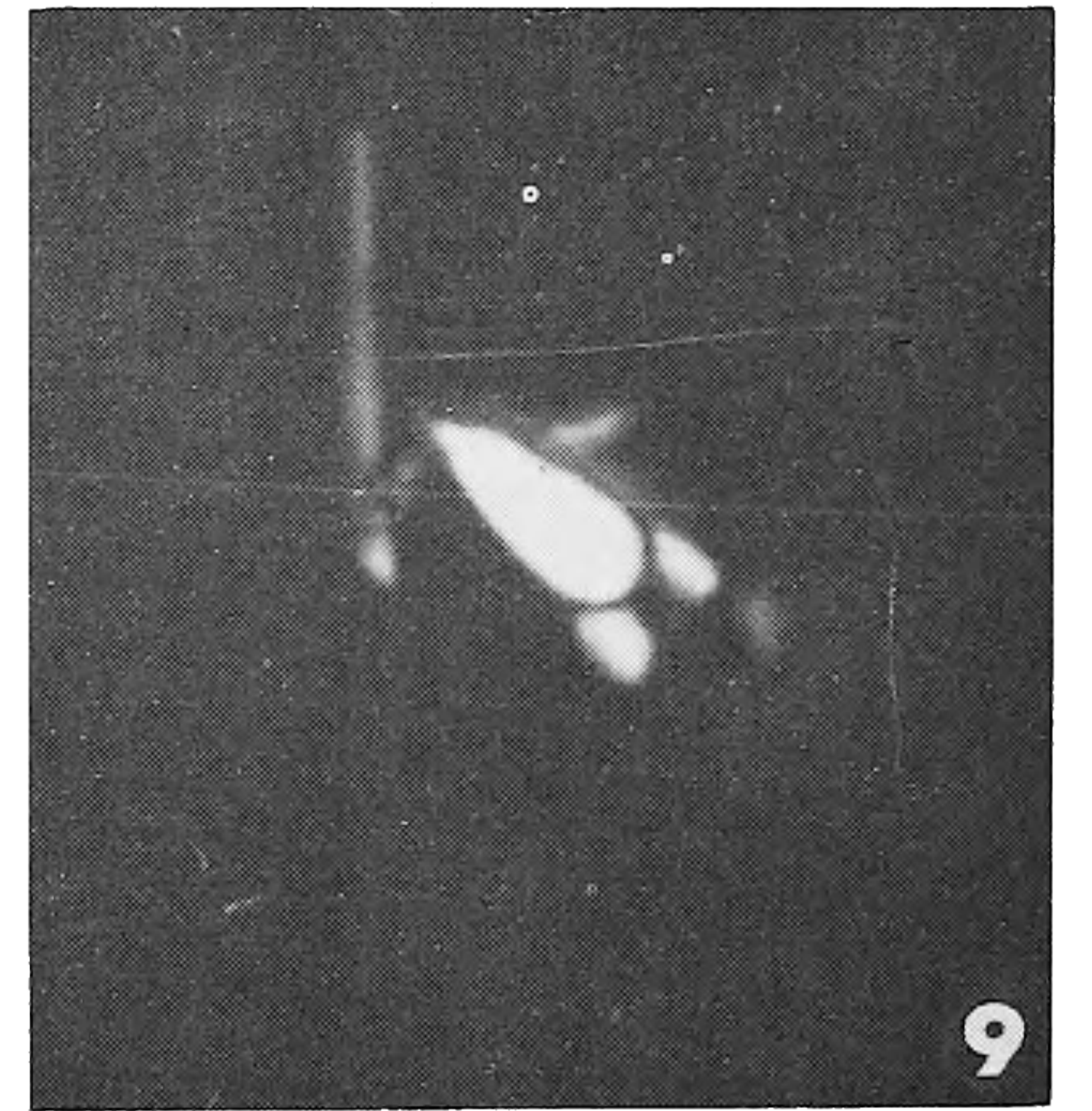
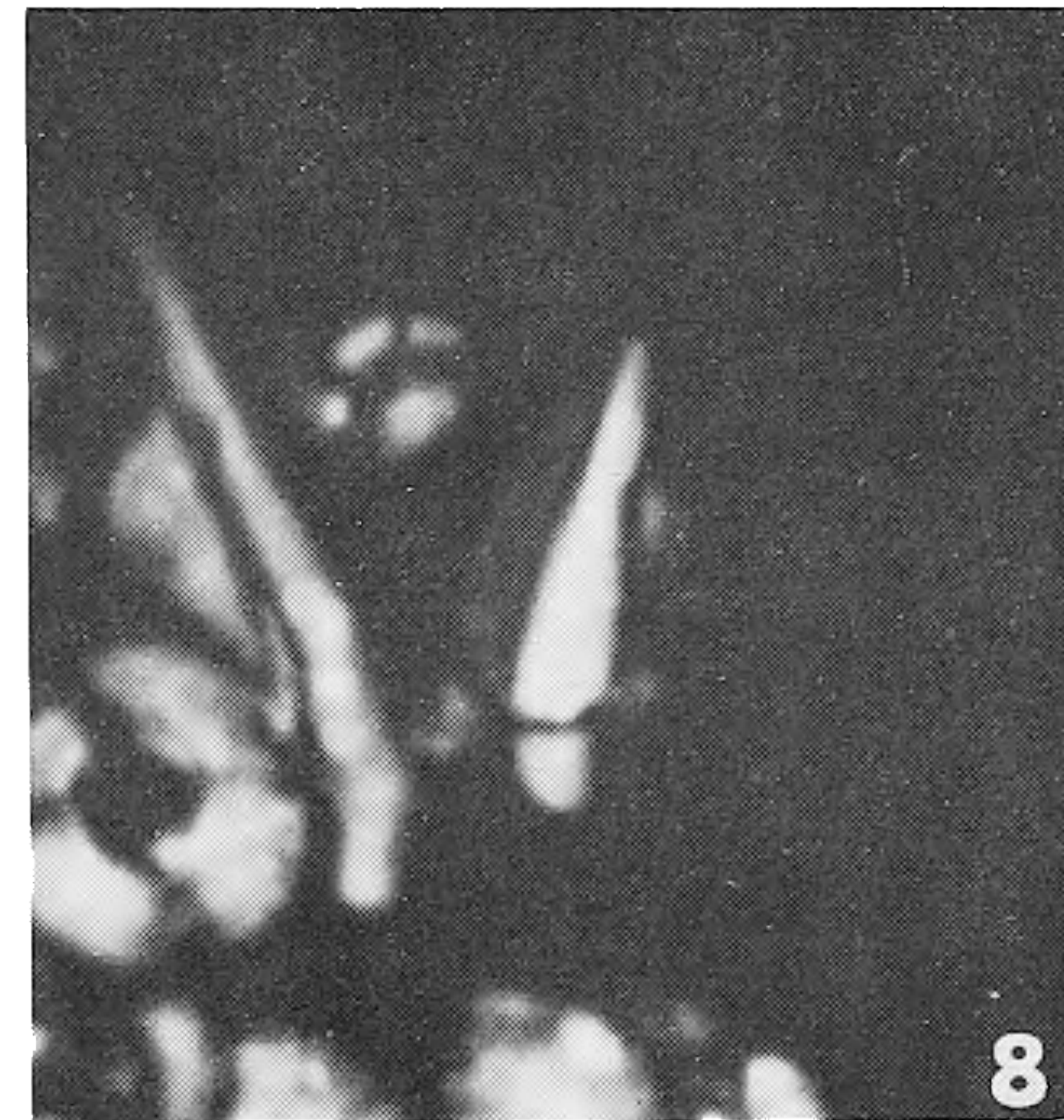
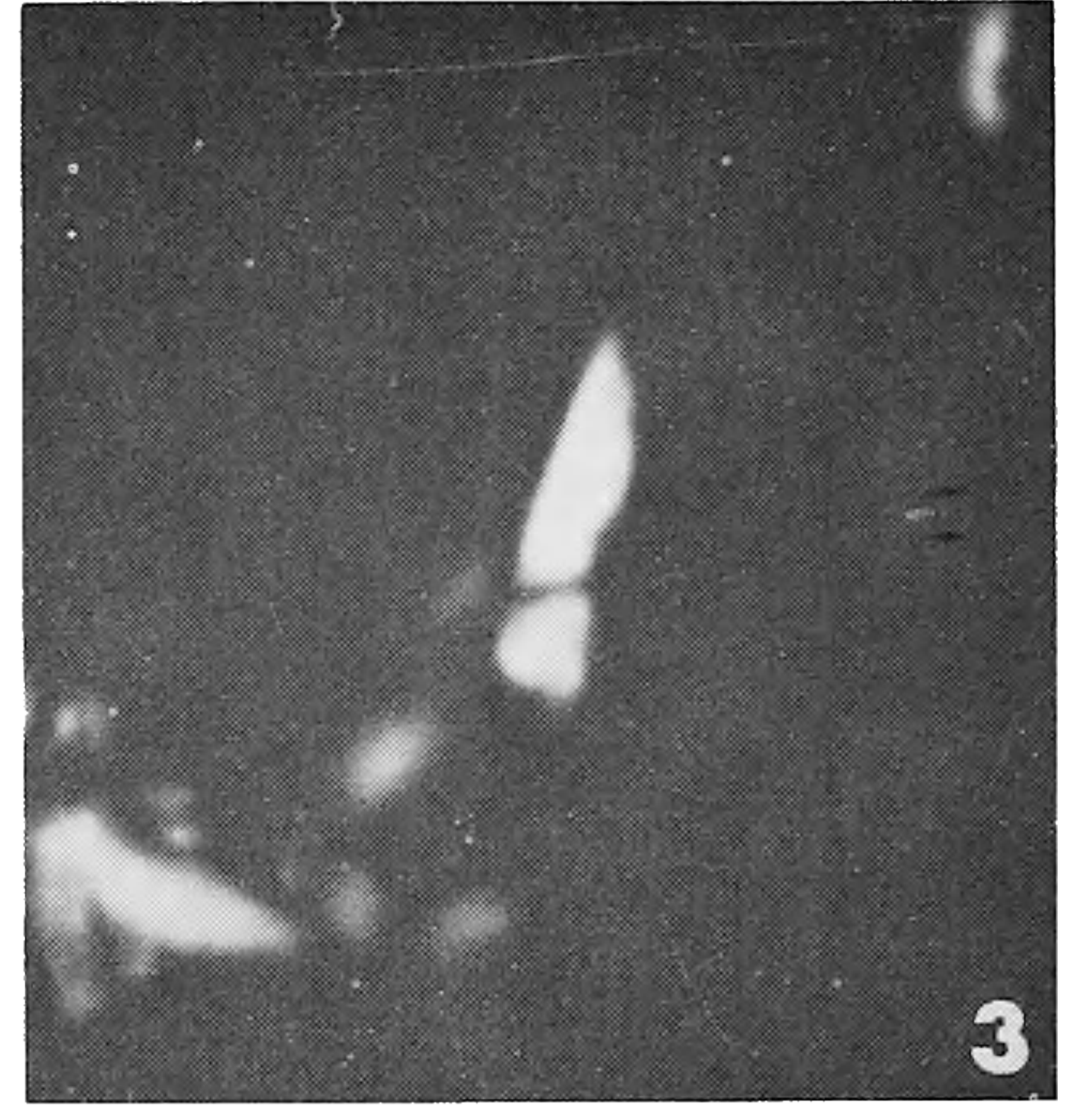
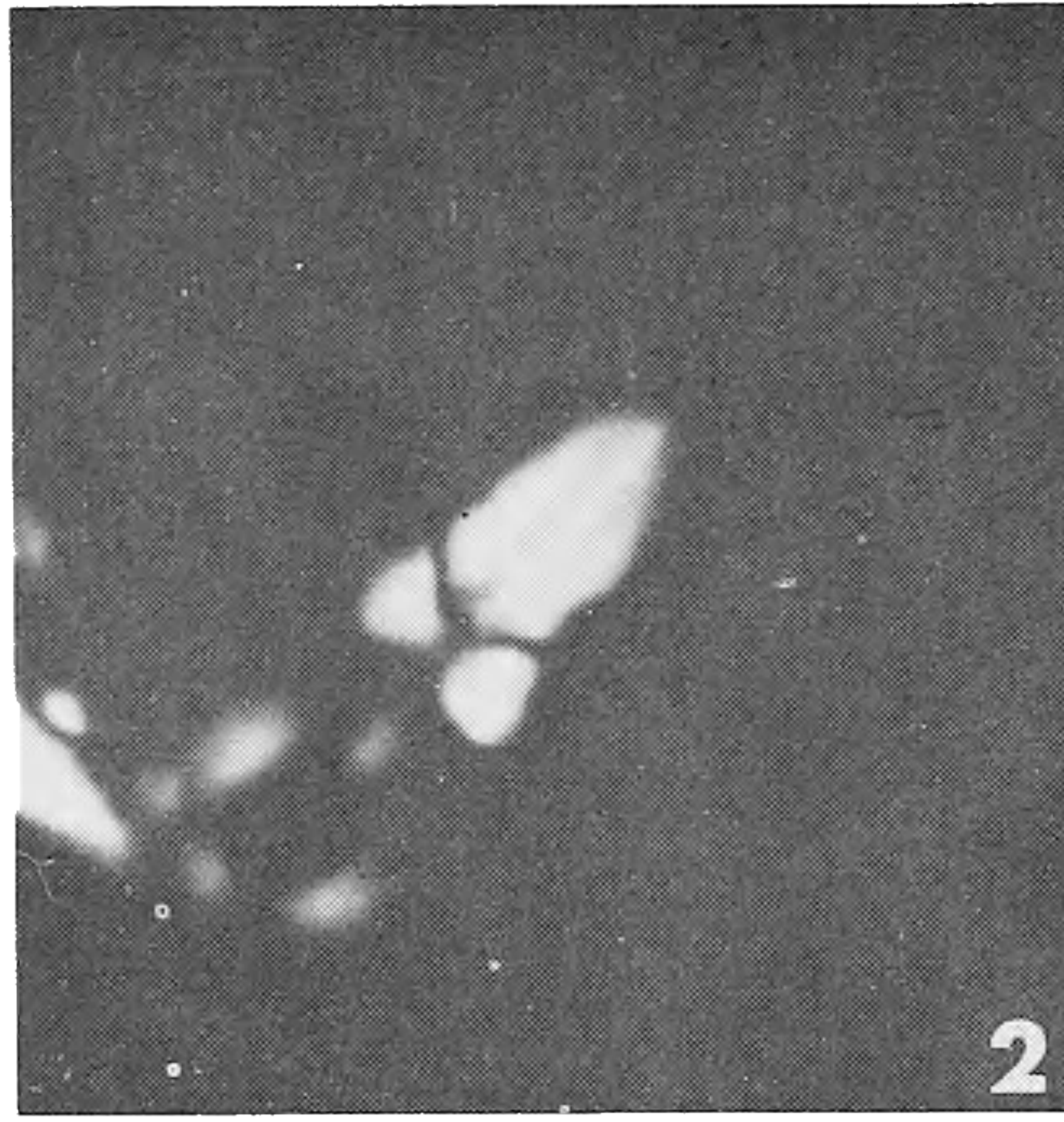
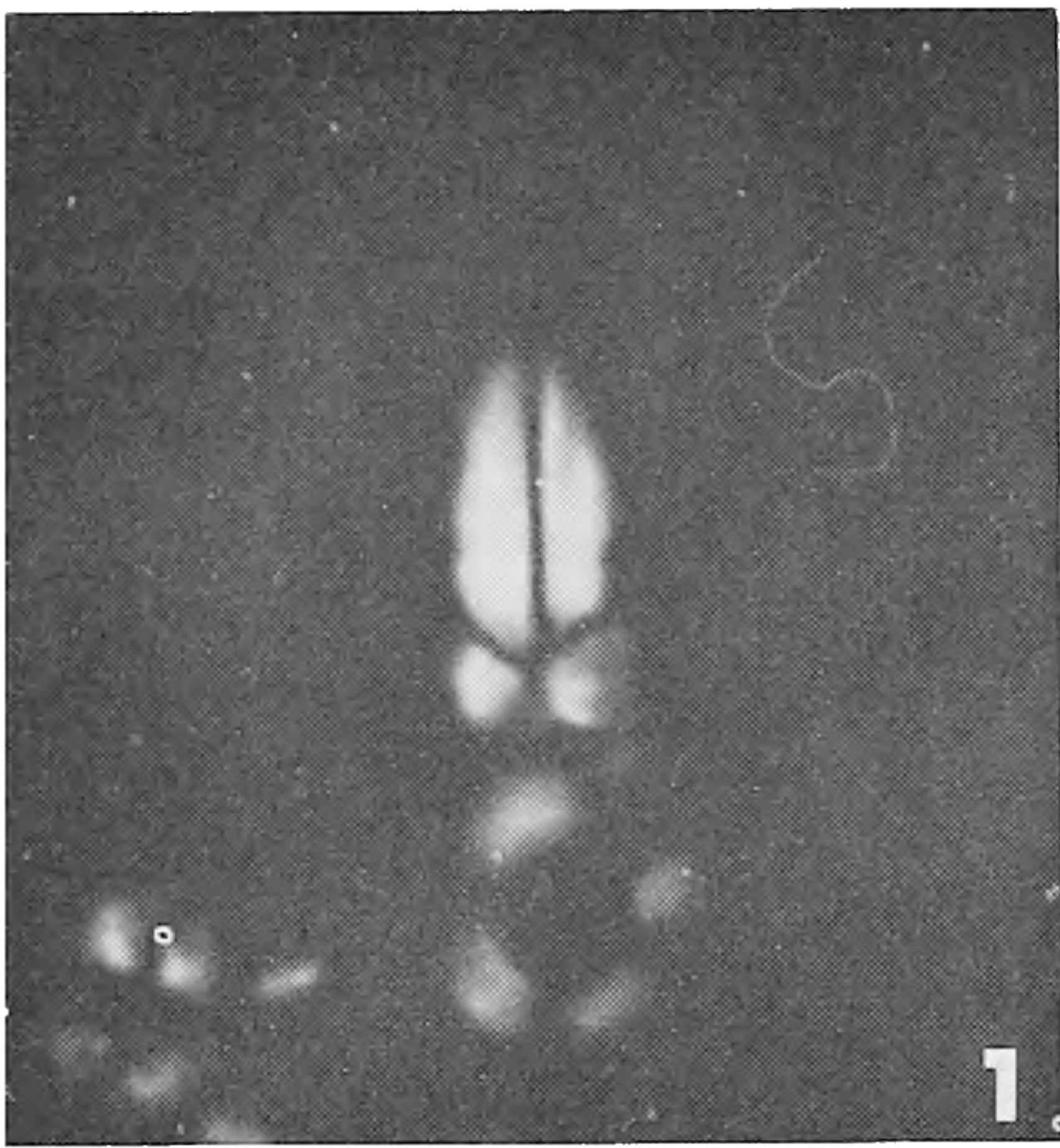

THIS PAGE IS LOCKED TO FREE MEMBERS
Purchase full membership to immediately unlock this page

DELVE INTO FANTASY, MAGIC, MYTHOLOGY & FOLKLORE

Forgotten Books'
Full Membership gives
access to 797,885 ancient
and modern, fiction and
non-fiction books.

Continue

*Fair usage policy applies

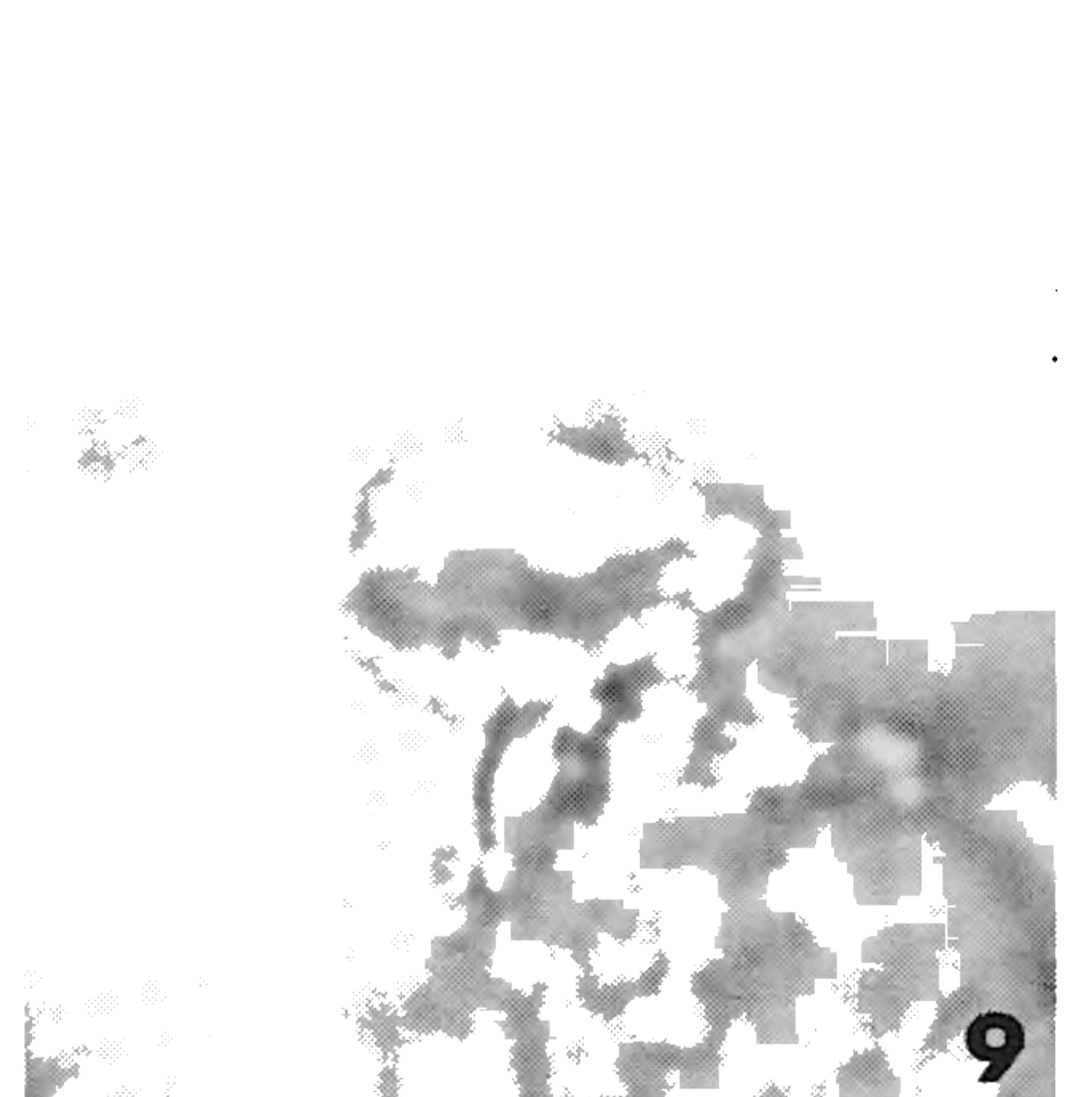
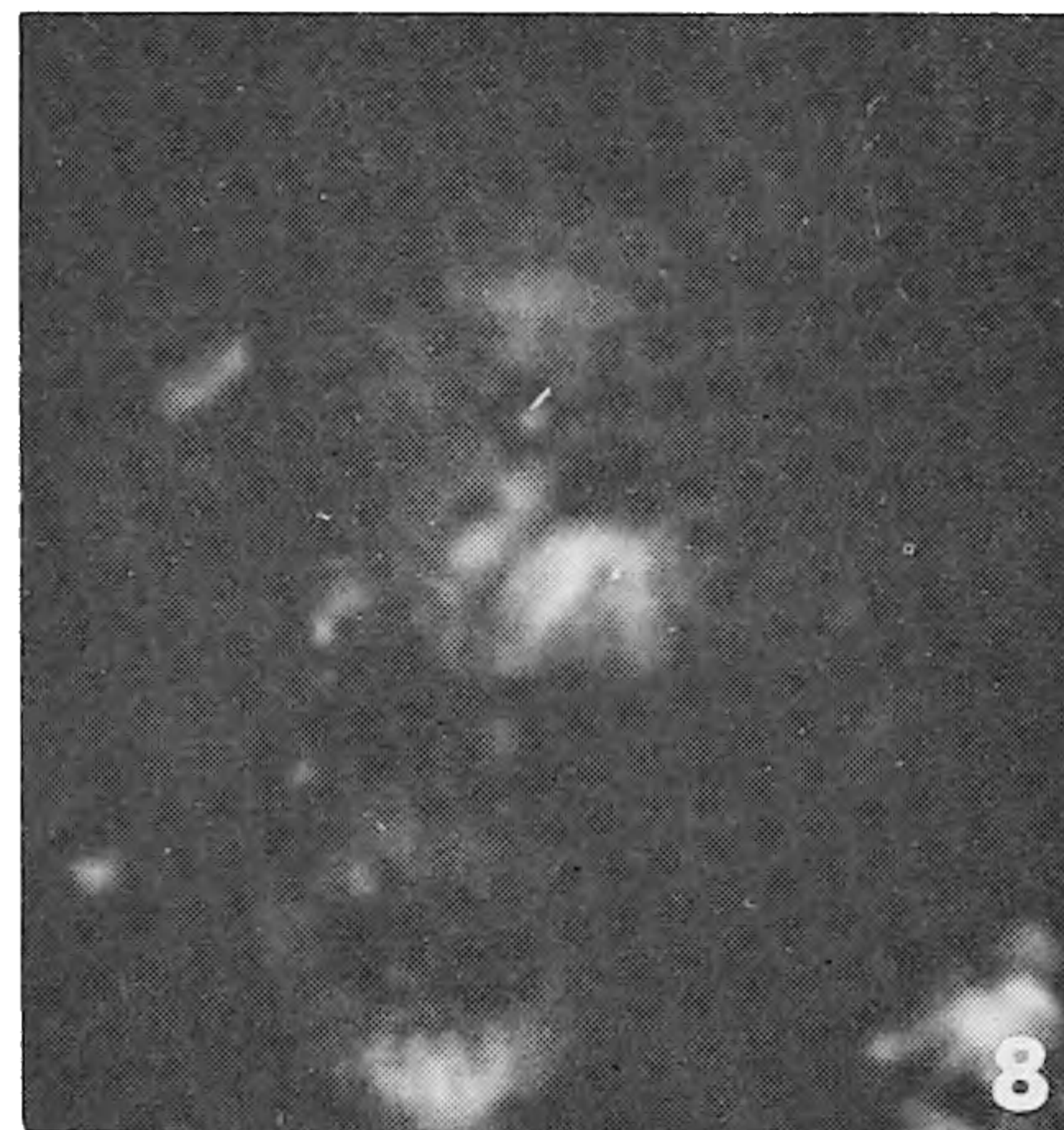
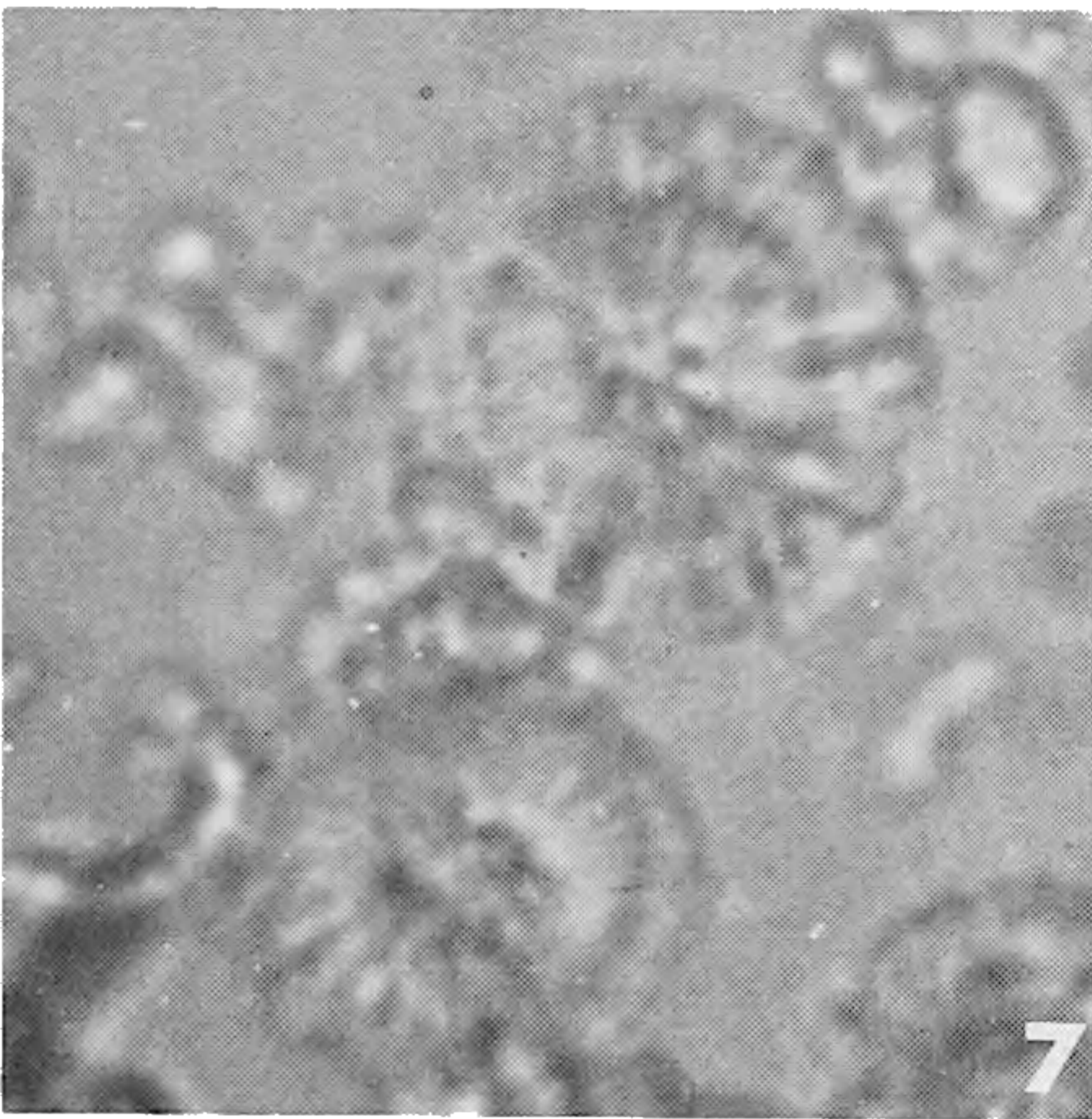
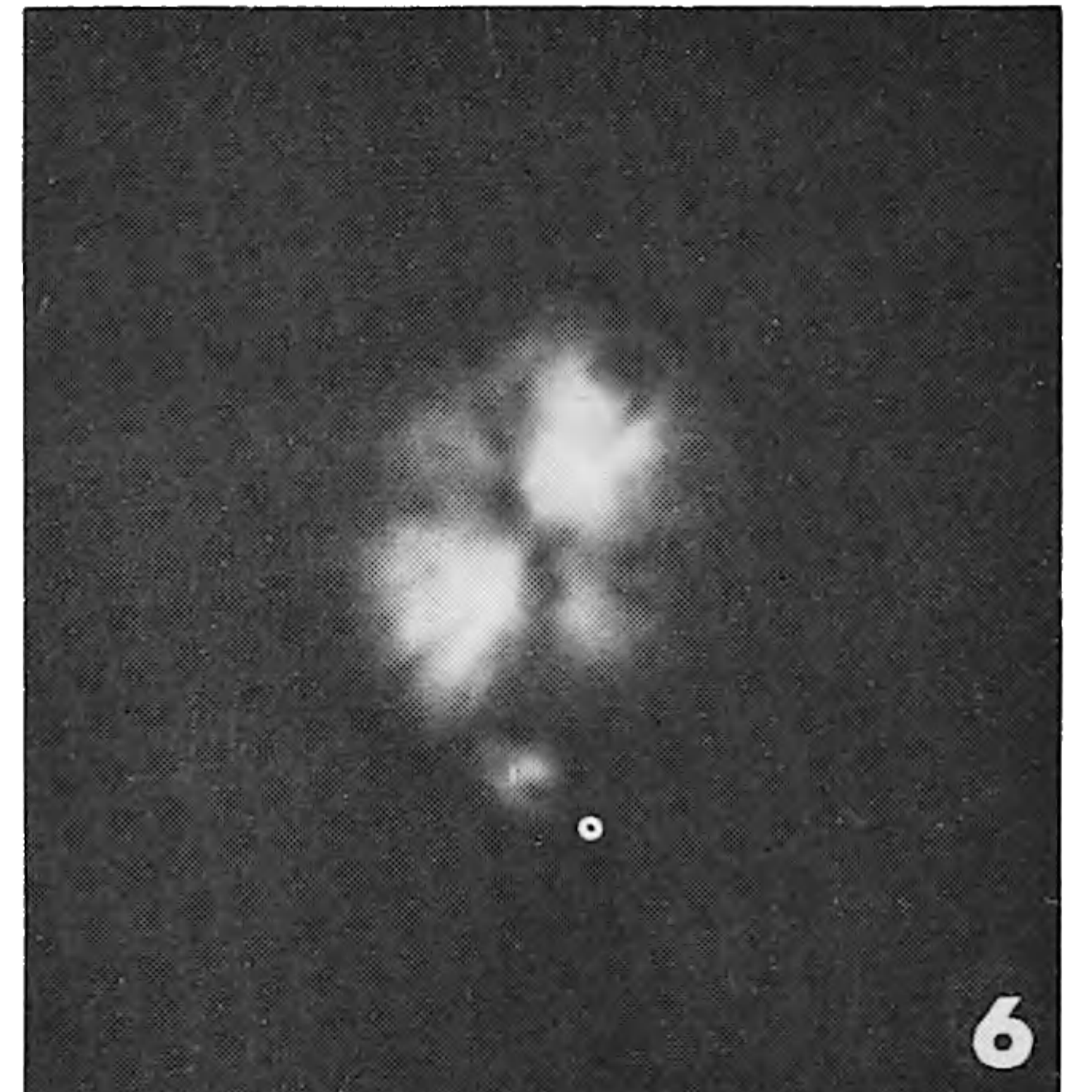
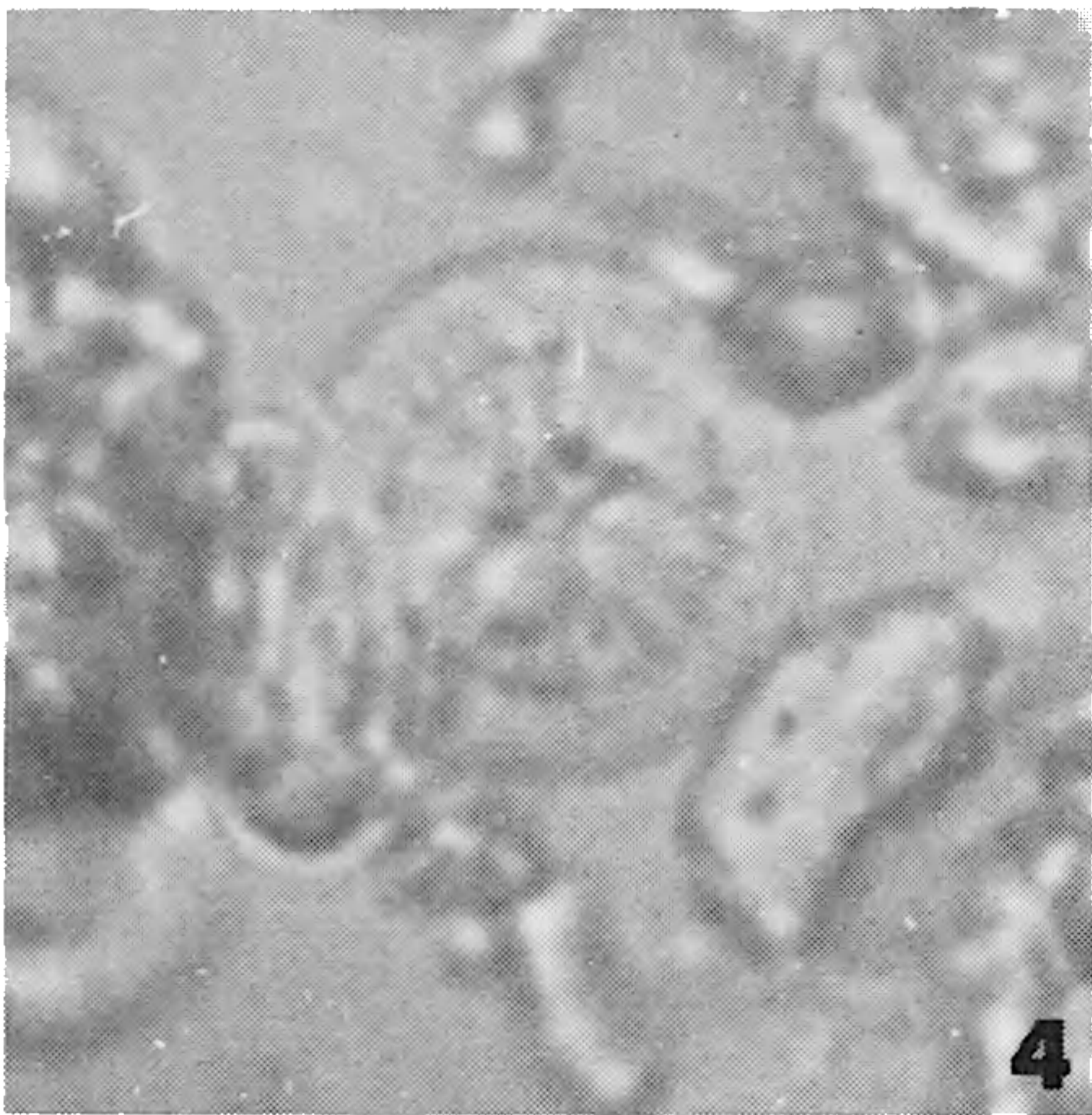
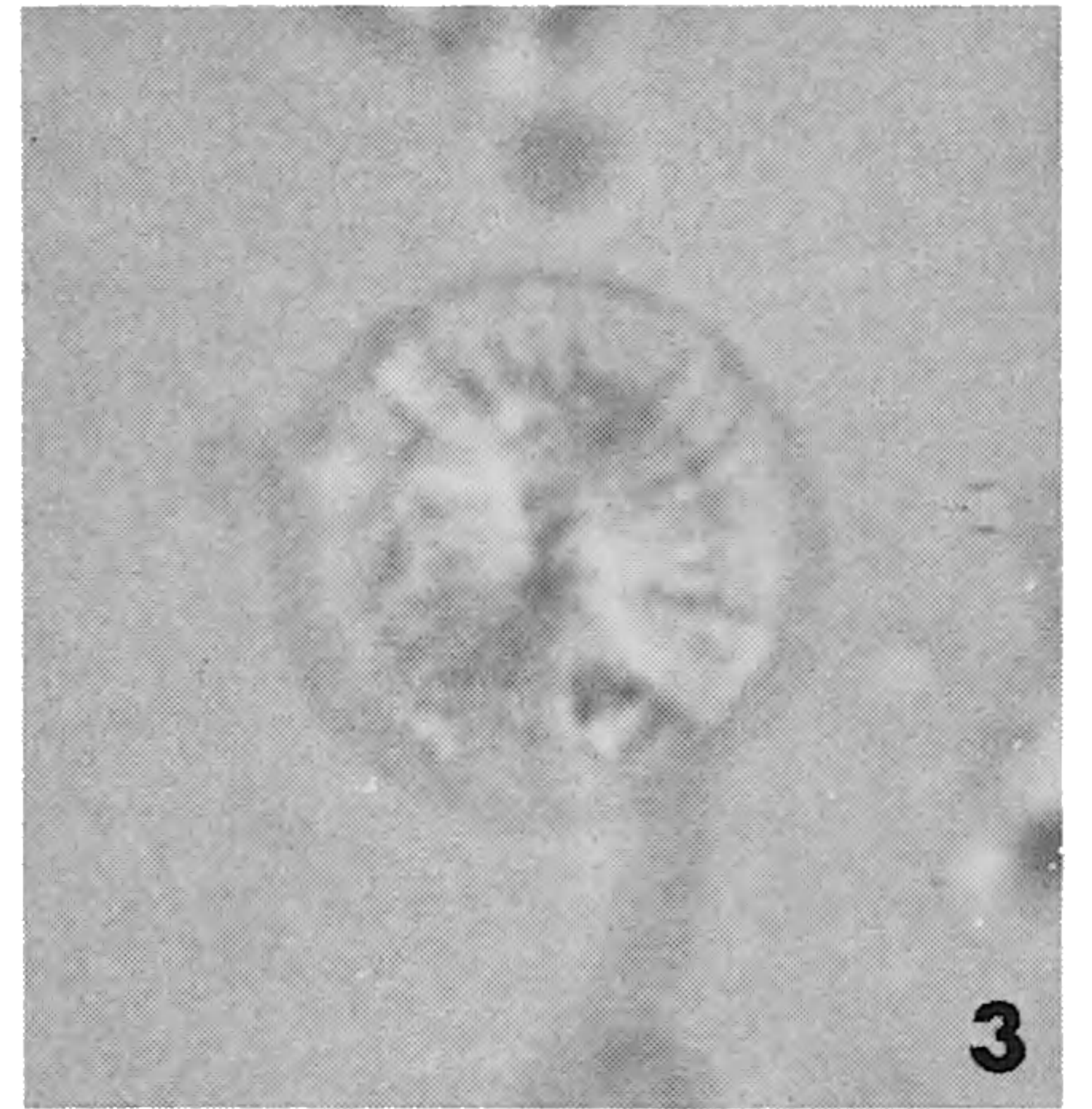
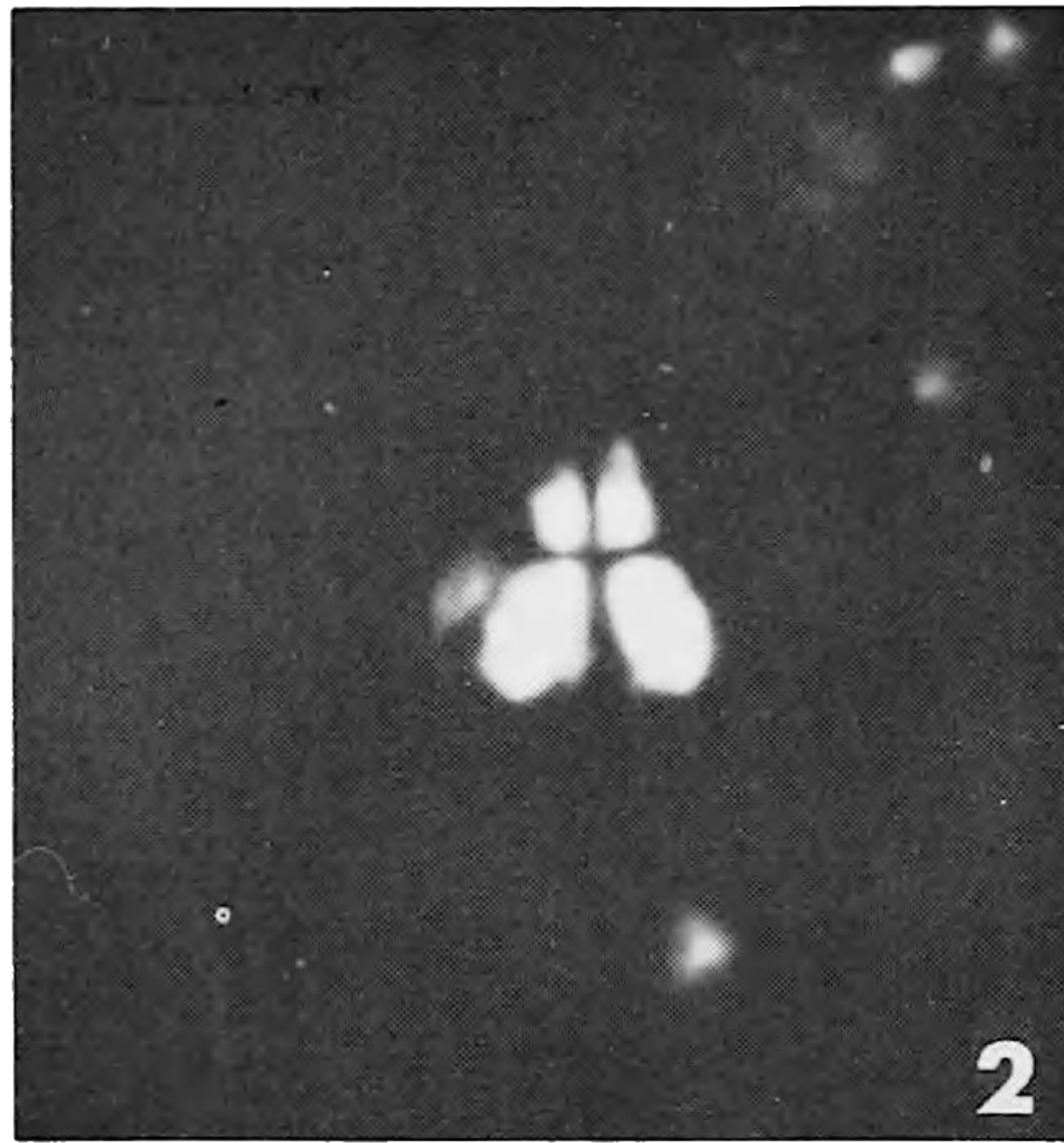
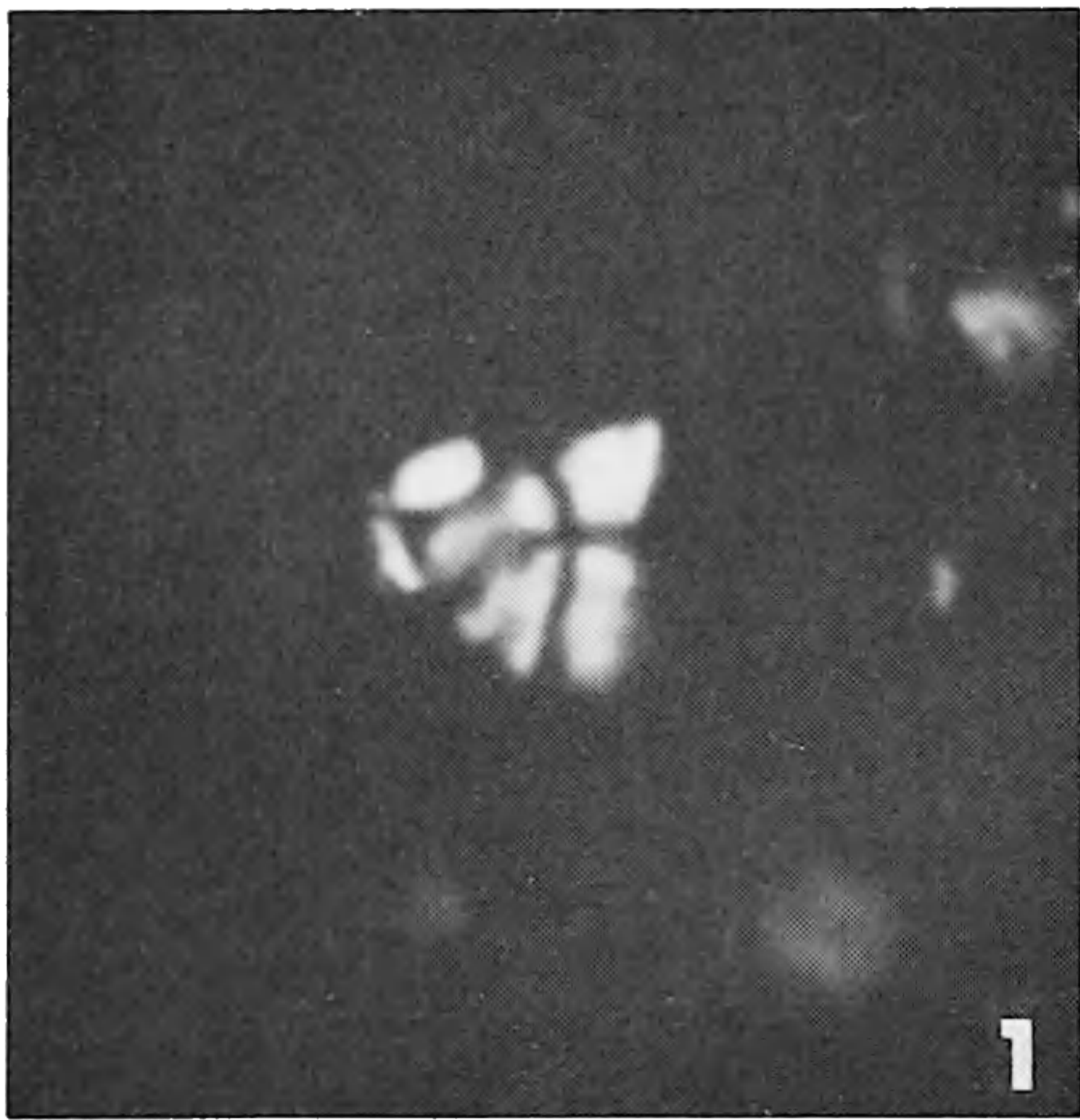

10

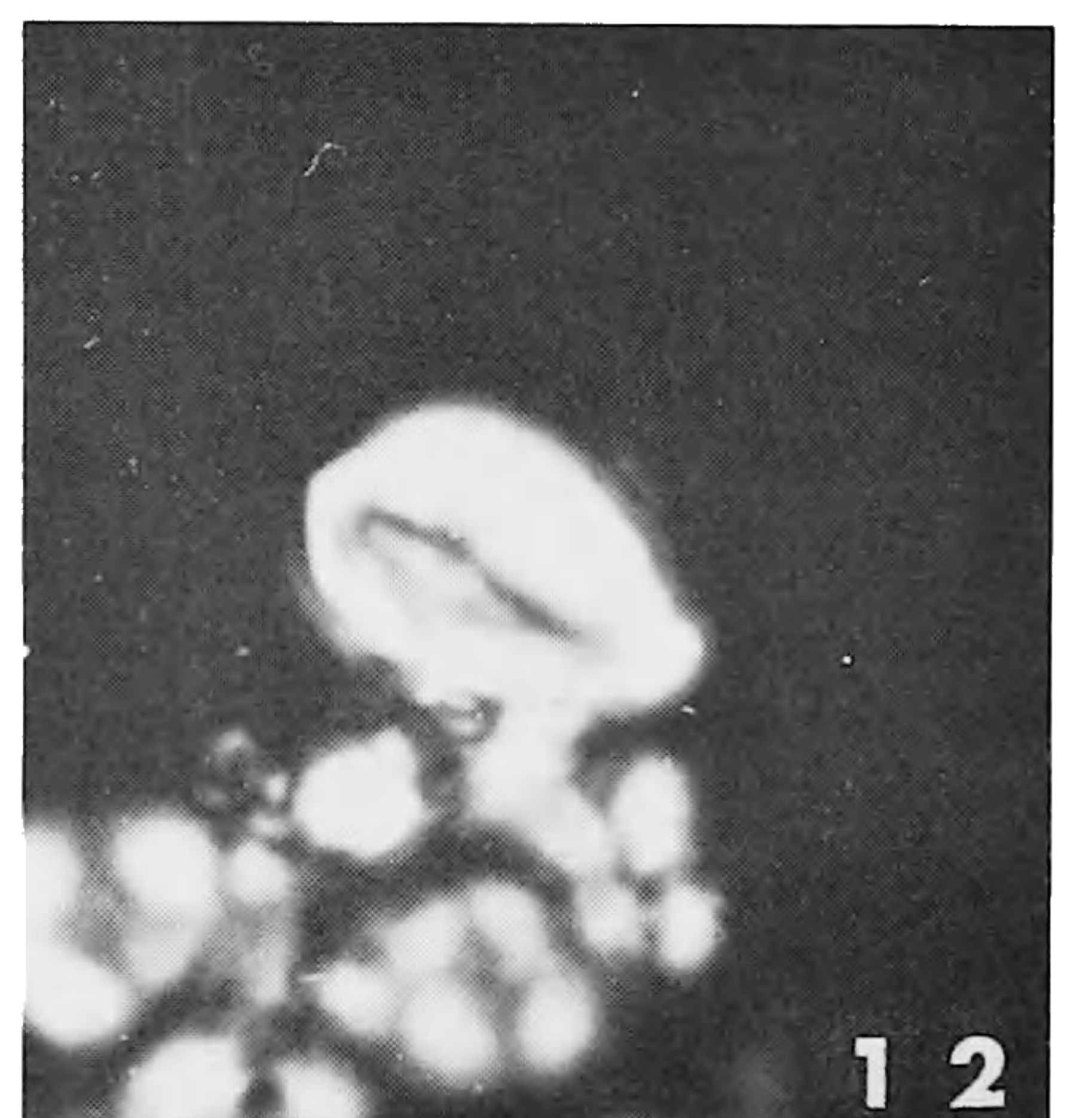
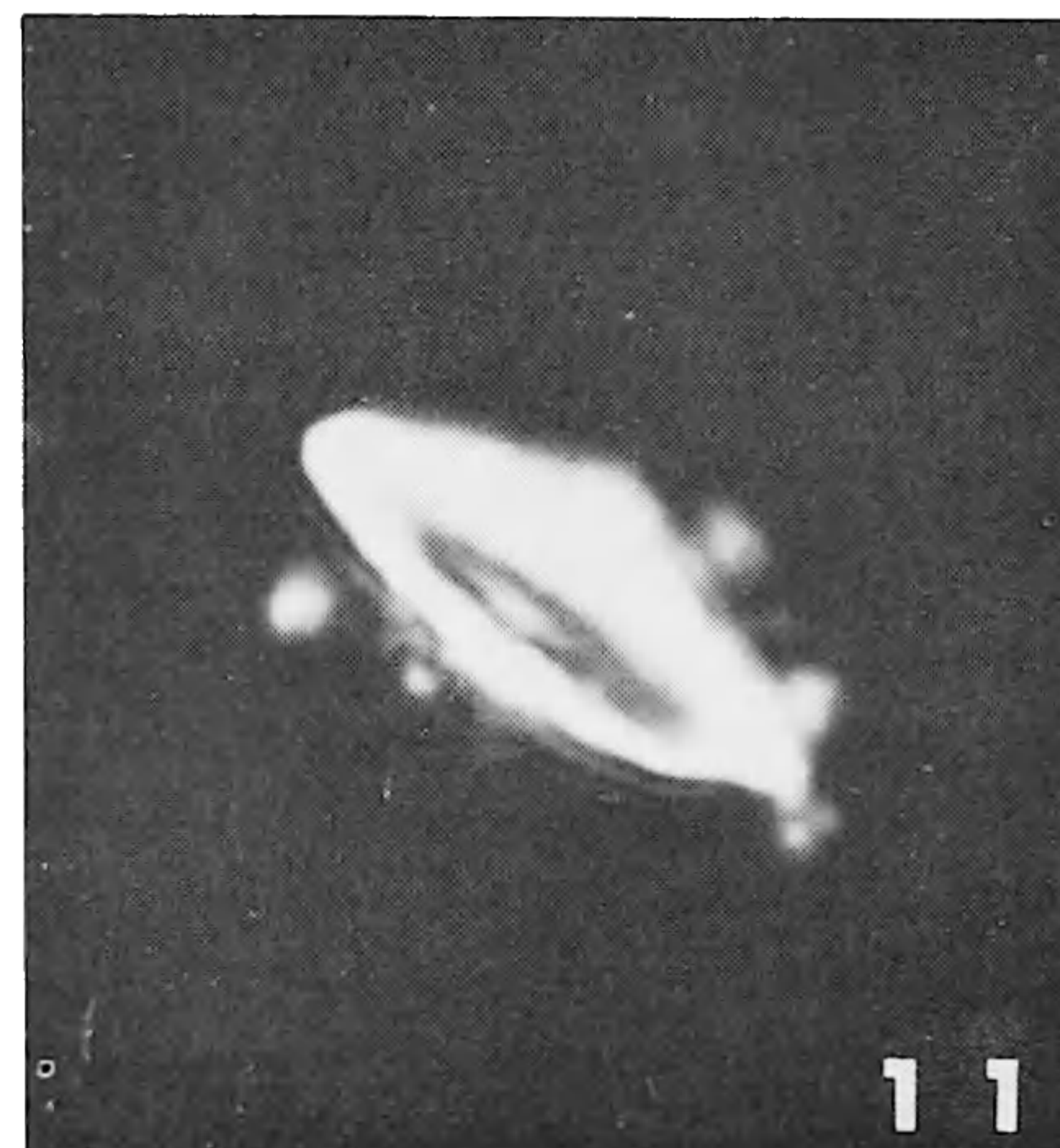

Occurrence.—*Striatococcolithus pacificanus* occurs through lower Eocene sediment of the Shatsky Rise in the Pacific Ocean.

Size.—10 to 14 microns.

Holotype.—USNM 176919 (Pl. 7, figs. 4-5).

Paratypes.—USNM 176918, 176920-176921.

Type locality.—DSDP 47.2-7-3, 82-83 cm, Shatsky Rise, northwestern Pacific Ocean.

Genus *Triquetrorhabdulus* Martini, 1965

***Triquetrorhabdulus milowii* n. sp.**

Pl. 7, figs. 9-12

Description.—This small species is constructed of three blades joined symmetrically at a common axis. Oriented in side view, the nannofossil outline, which is formed by two of the blades, is elliptic to rounded rhomboid. In this same orientation, the third blade is seen in edge view. Maximum relief above the mounting medium ($n=1.518$) and maximum birefringence occur at 45° to the polarization directions. In cross-polarized light, the typical color pattern of yellow for the two blades in profile, red for the area next to the third blade (edge view), and blue for the third blade, is a measure of the various thicknesses of the nannofossil at this orientation. Minimum relief and birefringence (dark) for the whole nannofossil is parallel with the polarization directions. Typically the width of the nannofossil is equal to one half or more of the length.

Remarks.—*Triquetrorhabdulus milowii* is distinctly shorter than any other species of *Triquetrorhabdulus*. It is distinguished from *T. inversus* Bukry and Bramlette and *T. rugosus* Bramlette and Wilcoxon by the orientation of the optic axis of the three blades. It is distinguished from *T. carinatus* Martini, with which it shares the same optic-axis pattern, by a shorter more “inflated” profile. *T. milowii* is typically one half or two thirds as wide as long and blade margins tend to be curved, whereas *T. carinatus* is only one third or one fourth as wide as long. Younger specimens of *T. milowii* tend to be shorter and more elliptic in outline than older specimens, with one end slightly wider than the other. This nannofossil has been recorded as *T. carinatus* [short] in Deep Sea Drilling Project reports on the tropical Pacific Ocean. The stratigraphic utility of this species was suggested by Dean Milow (pers. comm., 1969).

Occurrence.—*Triquetrorhabdulus milowii* is common to rare in lower Miocene sediments of the Pacific Ocean and Ciperio section of Trinidad. Early forms of *T. milowii* overlap the upper range of *T. carinatus* in the *Triquetrorhabdulus carinatus* Zone, but *T. milowii* persists upward into the *Sphenolithus belemnus* Zone and possibly into the lower *Helicopontosphaera ampliapertura* Zone, which are above the range of *T. carinatus*.

Size.—6 to 12 microns.

Holotype.—USNM 176922 (Pl. 7, figs. 9 and 12).

Paratype.—USNM 176923.

Type locality.—DSDP 74.0-4-4, 63-64 cm, western flank East Pacific Rise, equatorial Pacific Ocean.

Plate 7. Photomicrographs: 2,000 X. 1-2. *Sphenolithus spiniger* n. sp. (1) USNM 176917, DSDP 44.0-4-6, 145-146 cm, cross-polarized, 45° , (2) cross-polarized, 0° . 3-8. *Striatococcolithus pacificanus* n. sp. (3) USNM 176918, DSDP 47.2-7-2, 100-101 cm, (4) holotype USNM 176919, DSDP 47.2-7-3, 82-83 cm, (5) holotype, cross-polarized, (6) USNM 176920, DSDP 47.2-7-3, 104-105 cm, cross-polarized, (7) USNM 176921, DSDP 47.2-7-3, 82-83 cm, (8) cross-polarized. 9-12. *Triquetrorhabdulus milowii* n. sp. (9) holotype USNM 176922, DSDP 74.0-4-4, 63-64 cm, 45° , (10) USNM 176923, 45° , (11) cross-polarized, 45° , (12) holotype, cross-polarized, 45° .

SAMPLE LOCALITIES

- DSDP 3 (23°01'N., 77°43'W.)
 DSDP 36 (40°59'N., 130°07'W.)
 DSDP 44.0 (19°19'N., 169°00'W.)
 DSDP 47.0 (32°27'N., 157°43'E.)
 DSDP 47.2 (32°27'N., 157°43'E.)
 DSDP 54.0 (15°37'N., 140°18'E.)
 DSDP 55.0 (9°18'N., 142°33'E.)
 DSDP 57.2 (8°41'N., 143°32'E.)
 DSDP 63.0 (0°50'N., 147°53'E.)
 DSDP 63.1 (0°50'N., 147°53'E.)
 DSDP 70.0 (6°20'N., 140°22'W.)
 DSDP 72.0 (0°26'N., 138°52'W.)
 DSDP 74.0 (6°14'S., 136°06'W.)
 DSDP 77B (0°29'N., 133°14'W.)
 DSDP 80 (0°58'S., 121°33'W.)
 DSDP 83A (4°03'N., 95°44'W.)
 STETSON 21, (38°58'N., 72°28'W.)
 Sample provided by M. N. Bramlette.

ACKNOWLEDGMENTS

The majority of the samples examined in this study were provided by the National Science Foundation through the Deep Sea Drilling Project.

I wish to thank M. N. Bramlette, Scripps Institution of Oceanography, R. G. Douglas, Case Western Reserve University, A. D. Warren, Mobil Oil Corporation, and G. W. Moore, U.S. Geological Survey for helpful discussions on various aspects of this paper. Publication has been authorized by the Director of the U.S. Geological Survey.

LITERATURE CITED

- Berger, W. H.
 1970. Biogenous deep-sea sediments: Fractionation by deep-sea circulation. *Geol. Soc. America Bull.* 81: 1385-1402.
- Berggren, W. A.
 1971. Tertiary boundaries and correlations. *In*, Funnell, B. M., and W. R. Riedel (eds.) *The micropaleontology of oceans*. Cambridge University Press, p. 693-809.
- Bramlette, M.N.
 1970. Calcareous nannoplankton. *U.S. Geol. Surv. Prof. Paper* 640-A: 18.
- Bramlette, M. N., and E. Martini
 1964. The great change in calcareous nannoplankton fossils between the Maestrichtian and Danian. *Micropaleontology* 10: 291-322.
- Bramlette, M. N., and W. R. Riedel
 1954. Stratigraphic value of discoasters and some other microfossils related to recent coccolithophores. *J. Paleont.* 28: 385-403.
- Bramlette, M. N., and J. A. Wilcoxon
 1967. Middle Tertiary calcareous nannoplankton of the Cipero section, Trinidad, W. I. *Tulane Studies Geol.* 5: 93-131.
- Bukry, D.
 1971. Coccolith stratigraphy Leg 7, Deep Sea Drilling Project. *Deep Sea Drilling Proj. Initial Repts.* 7: 1513-1528.
 Coccolith stratigraphy Leg 16, Deep Sea Drilling Project. *Deep Sea Drilling Proj. Initial Repts.* 16, in press.
- Bukry, D., and M. N. Bramlette
 1970. Coccolith age determinations Leg 3, Deep Sea Drilling Project. *Deep Sea Drilling Proj. Initial Repts.* 3: 589-611.
- Chave, K. E., and E. Suess
 1967. Suspended minerals in seawater. *New York Acad. Sci. Trans.* 29: 991-1000.

THIS PAGE IS LOCKED TO FREE MEMBERS
Purchase full membership to immediately unlock this page

FORGOTTEN BOOKS

FULL MEMBERSHIP

797,885 Books!
All you can read
for only
\$8.99/month

Continue

*Fair usage policy applies



**AN UPPER PLEISTOCENE MARINE FAUNA
FROM MISSION BAY,
SAN DIEGO, CALIFORNIA**

**J. PHILIP KERN, TOM E. STUMP,
AND ROBERT J. DOWLEN**

TRANSACTIONS

**OF THE SAN DIEGO
SOCIETY OF
NATURAL HISTORY**

VOL. 16, NO. 15 29 DECEMBER 1971

THIS PAGE IS LOCKED TO FREE MEMBERS
Purchase full membership to immediately unlock this page

DELVE INTO FANTASY, MAGIC, MYTHOLOGY & FOLKLORE

Forgotten Books'
Full Membership gives
access to 797,885 ancient
and modern, fiction and
non-fiction books.

Continue

*Fair usage policy applies

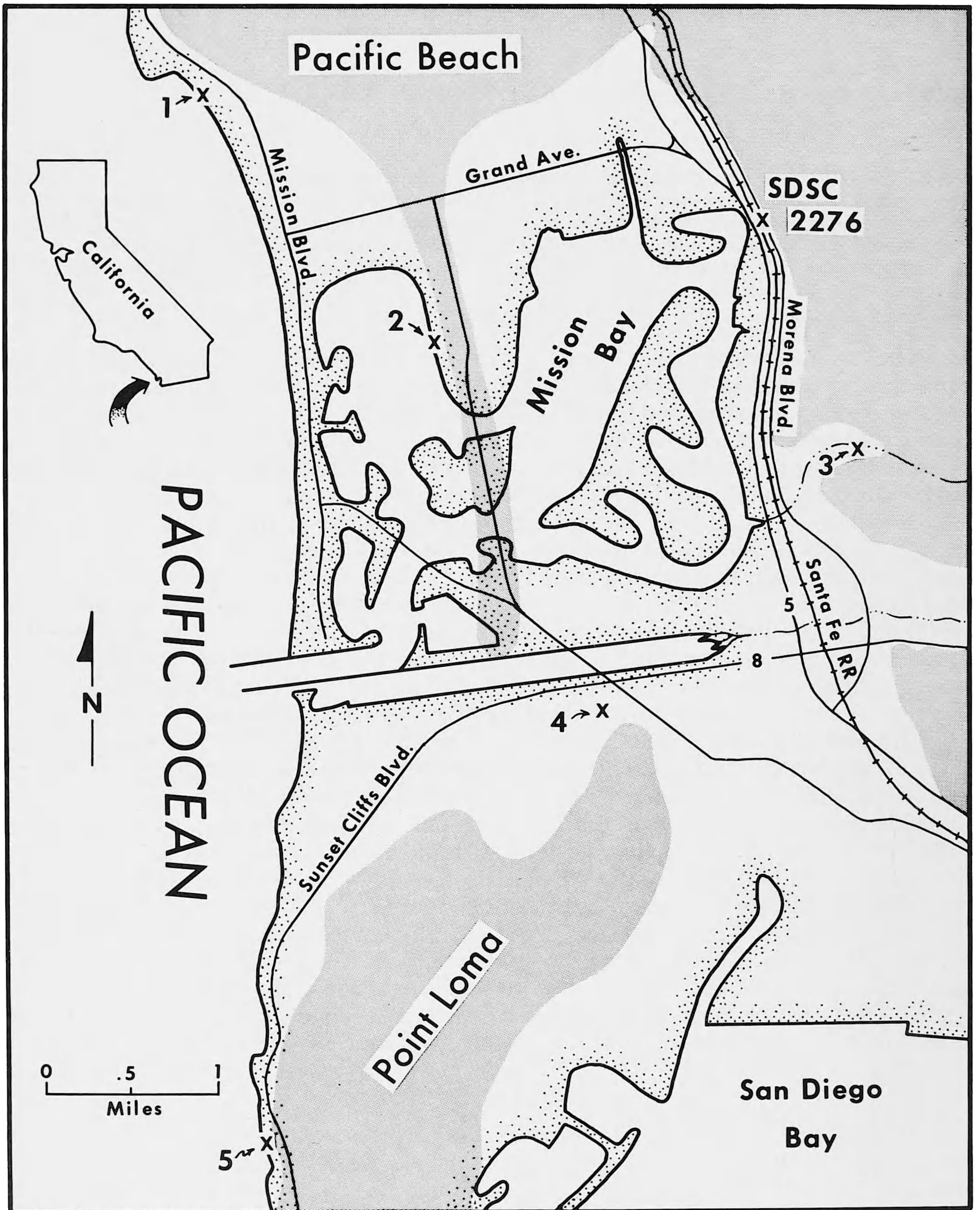

Figure 1. Map of the Mission Bay area showing the location of San Diego State College locality 2276 (Stephens' railroad cut locality) and other Bay Point Formation fossil localities at Pacific Beach (1), Crown Point (2), Tecolote Creek (3), south Mission Bay (4), and Sunset Cliffs (5). Inferred late Pleistocene land areas are shaded. The extension of the barrier beach south of Crown Point is based on the presence of sheltered-bay fossil faunas behind the barrier and the typical development of such barriers today. Probably the barrier was alternately open and closed.

the conglomerate grades rather abruptly upward into somewhat better sorted, poorly consolidated, fine-grained, brown sand. There is a slight upward decrease in grain size through the upper part of the section. Grain-size analyses for the beds described below are shown in Table 1.

Table 1. Sediment grain-size analyses made by the dry sieve method described by Folk (1968: 34-36). Ranges are given because two or more samples from each bed were analyzed.

	<i>coarser than sand</i> $< -1\phi$	<i>coarse sand</i> -1ϕ to 1ϕ	<i>medium sand</i> 1ϕ to 2ϕ	<i>fine sand</i> 2ϕ to 4ϕ	<i>silt and clay</i> $> 4\phi$
bed 3	1-4%	5-12%	12-22%	53-70%	9-12%
bed 2	2-6	4-7	22-31	54-60	4-12
bed 1	30-32	14-16	21-22	24-31	4-6
conglomerate	70	8	9	10	3

Fossils are distributed irregularly throughout the section above the lower part of the conglomerate. Collections were made from three rather arbitrarily defined stratigraphic intervals in order to evaluate temporal changes in the fauna. Bed 1 is a highly fossiliferous stratum in the upper 15 to 30 cm of the conglomerate (Fig. 3). Bed 2 is a poorly defined fossiliferous interval from 30 to 45 cm thick directly overlying bed 1. Bed 3 is an irregular stratum 30 cm thick and 15 cm above the top of bed 2.

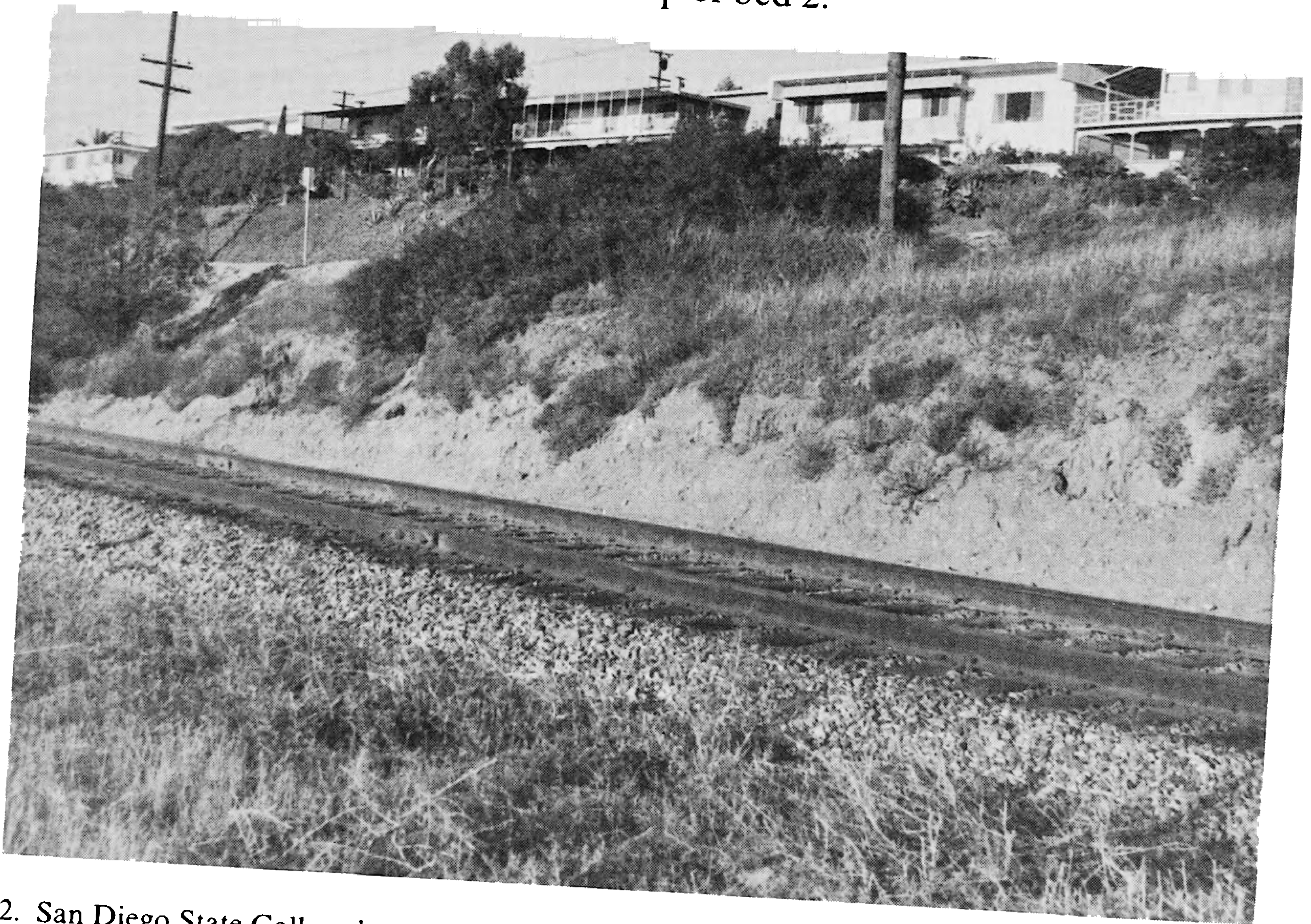

Figure 2. San Diego State College locality 2276 viewed from the southwest. The tracks of the Santa Fe Railroad are in the foreground, and the houses in the background are east of Morena Boulevard. Exposure A is the excavation in the bank directly below the street sign near the left edge of the view; exposure B is the smaller excavation at the right edge of the view. The lower parts of both excavations were filled in after the collections were made and before this photograph was taken. Fossils that have weathered out on the bank are visible between the two exposures.

METHODS AND FAUNAL LIST

Each bed was sampled at two exposures, designated A (at the northern end of the outcrop) and B (10 m to the south of A; Fig. 2). We collected 18 to 22 kg of sediment and fossils in each sample except the one from 2A, which was twice that size. Each sample was washed through a 10-mesh (2 mm) screen, and all identifiable fossil specimens were picked from the material retained in the screen. Sediment passing through the screen was examined for microfossils but none were found.

Sixty-seven species of mollusks, one chordate species, and borings of unidentified species of *Polydora*, an annelid, and *Cliona*, a sponge, have been identified. The distribution and abundance in the three beds of those species collected during this study are shown in Table 2. Also indicated in Table 2 are species present in earlier San Diego State College collections from this locality and in the collections of the San Diego Natural History Museum. The latter include at least part of Stephens' (1929: 253) collection from this locality, though we have not been able to find two of the species he listed, *Macoma calcarea* and *Phacoides californica*. His *Macoma* probably is *Psammotreta viridotincta*, which is common in his collection, but that collection now contains no specimens likely to be confused with *Phacoides* [= *Lucina*] *californica*.

AGE OF THE FAUNA

Odostomia diegensis is the only species in this fauna not known to be living. Addicott and Emerson (1959: 24) suggested that all essentially modern fossil faunas preserved at the lowest emergent terrace level in southern California probably are correlative with the regional type upper Pleistocene Palos Verdes Sand at San Pedro. The Bay Point Formation, which is deposited in part on this terrace, probably is correlative, then, with upper Pleistocene deposits at San Pedro, Cayucos, and San Nicolas Island that have been dated radiometrically at between $95,000 \pm 15,000$ and $140,000 \pm 30,000$ years (see discussion in Kern, 1971: 812). These faunas may have lived during Sangamon interglacial time or during an earlier interglacial episode.

ENVIRONMENT OF DEPOSITION

Environmental interpretations are based on distribution data for living species from Berry (1922), Oldroyd (1927), Grant and Gale (1931), Burch (1944-1946), Hertlein and Strong (1955), Morris (1966), Ricketts and Calvin (1968), McLean (1969), and Keen (1971). The fossil fauna is characteristic of the protected-bay environment, consistent with the probable paleogeographic setting of the locality (Fig. 1). However, the inferred coastline suggests that this shore was exposed to over a mile of open water behind the barrier beach, and several molluscan species also suggest that the fauna lived in a somewhat exposed part of the bay. *Littorina scutulata*, a common species at this locality, is most abundant today in the less protected parts of bays (Ricketts and Calvin, 1968: 237). *Lottia gigantea* and *Mopalia ciliata*, rare species in this fauna, are characteristic of a protected outer coast (Ricketts and Calvin, 1968: 26, 138), but they may occur rarely in the relatively exposed parts of bays.

ORIGIN OF FAUNAL ASSEMBLAGE

The composition of the fossil fauna and the abundance of worn and broken shells that are concentrated in irregular beds, lenses, and pockets reflect local reworking of sediment and mixing of shells from slightly different depth zones. *Littorina planaxis*, *L. scutulata*, *Assiminea translucens*, *Melampus olivaceus*, and *Heterodonax bimaculatus* live at or

THIS PAGE IS LOCKED TO FREE MEMBERS
Purchase full membership to immediately unlock this page

FORGOTTEN BOOKS

FULL MEMBERSHIP

797,885 Books!
All you can read
for only
\$8.99/month

Continue

*Fair usage policy applies



near high tide level where few other marine species live, and *Cerithidea californica* is most common on middle intertidal mud and sand flats where few other species are abundant. Yet at this locality these species are part of a rather diverse assemblage of invertebrates, most of which extend from the lower part of the intertidal zone into deeper water. Because of the relative turbulence of the intertidal zone, even in sheltered environments, such mixing of species from different intertidal levels is not unexpected.



Figure 3. Exposure A at San Diego State College locality 2276. The lower part of the excavation has been covered since the collections were made, and the basal conglomerate and bed 1 are no longer exposed. The abundant fossils in the lower part of the exposure are in bed 2, and the small lens of fossils higher in the exposure is in bed 3. The irregularity and discontinuity of these beds is evident. The pencil is 13 cm long.

However, in spite of this evidence for turbulent conditions and local reworking of sediment, there apparently was no large-scale sediment transport. With the few exceptions described below all the species in this fauna live in the intertidal zone of sheltered bays; thus there was no mixing of shells from widely different environments. *In situ* preservation of the majority of species is suggested by the presence of approximately equal numbers of right and left valves of several bivalve species and by high percentages of articulated specimens of *Lucina nuttallii*, *Diplodonta sericata*, *Chione californiensis*, *Psammotreta viridotincta*, and *Tagelus californianus*. The deeply burrowing *T. californianus* commonly is preserved in life orientation in these beds.

WATER DEPTH

This fauna clearly lived in sediments deposited in or very near the intertidal zone. The shoreline angle of the Nestor terrace in this area is not more than 2 or 3 m higher

than the fossil-bearing beds. *Littorina scutulata*, *Cerithidea californica*, *Melampus olivaceus*, *Pedipes liratus*, and *Septifer bifurcatus* are relatively abundant and they are restricted today to the intertidal zone, as are the less abundant *Lottia gigantea*, *Lucapinella callomarginata*, *Littorina planaxis*, *Assimineia translucens*, and *Heterodonax bimaculatus*. All but four of the other species range from the intertidal zone into deeper water.

One of the four exceptions, *Crassinella branneri* is common in this fauna, and the genus has a reported depth range of 2 to 40 m (Keen, 1963: 105). *Psammotreta viridincta*, also common, occurs today "mostly offshore in depths to 14 fathoms" (Keen, 1971: 231). However, the depth significance of this species is not clear because its present-day minimum depth is not known, and the change in its geographic range since late Pleistocene time (Table 3) suggests that its environmental tolerance limits may have changed. The collections also include four specimens each of *Nucula* aff. *N. exigua* and *Pitar newcombianus*. The former is known to live today in depths of 11 to about 2000 m (Keen, 1971: 26) and the latter in depths of 9 m or more (McLean, 1969: 78). Though these depth ranges are inconsistent with those described above, the few specimens of these two species do not warrant substantial modification of the suggested depth interpretation, especially in light of the questionable identity of the *Nucula*. However, the presence of these four apparently subtidal species in the fauna suggests that deposition may have occurred, at least in part, slightly below the intertidal zone.

Bed 3 contains fewer species than beds 1 and 2, and most of the abundant species in bed 3, including *Littorina scutulata*, *Cerithidea californica*, *Nassarius tegula*, *Melampus olivaceus*, *Chione fluctifraga*, and *Tagelus californianus*, today are restricted to or are most abundant in the intertidal zone. The other common species in bed 3, *Diplodonta sericata*, *Protothaca staminea*, and *Tellina meropsis*, are more abundant in bed 2, and these species are not restricted to or most abundant in the intertidal zone today. The four possibly subtidal species are uncommon in bed 3. Thus bed 3 apparently was deposited in the lower part of the intertidal zone, perhaps 1 m below mean sea level, and bed 1 was deposited in water perhaps 1 m deeper. Probably sea level was stable throughout the period of deposition, and the change in water depth reflects the thickness of sediments, about 1 m, deposited from bed 1 through bed 3. The base of the outcrop is approximately 14 m above present mean sea level, so sea level when these sediments were deposited probably was about 16 m higher than it is today. The shoreline angle of the Nestor terrace in this area is within 30 m to the east and no more than 2 or 3 m higher than locality 2276, suggesting that at this level the sea was close to its maximum extent on the terrace. The approximate position of the coastline at that sea level is shown in Figure 1.

The terrace deposits at Tecolote Creek (Fig. 1) are at a present elevation of 6 to 8 m at the base of the section and 14 to 16 m at the top. The fauna (Emerson and Chace, 1959: table 1) includes nearly all the intertidal species present at locality 2276, though their distribution within the section is now known. Possibly the lowest beds were deposited somewhat offshore in depths of 8 to 10 m and the highest beds, at about the same elevation as the beds at locality 2276, were deposited in or near the intertidal zone after this part of the basin had filled with sediments. Alternatively, sea level may have been rising during deposition of these sediments.

Valentine (1959: 685, 687) suggested that maximum sea level during cutting of the Nestor terrace at Crown Point, Pacific Beach, and Sunset Cliffs (Fig. 1) was between 60 and 70 feet (18 and 20 m) above present sea level and that the shallow-water assemblage at Crown Point, at a present elevation of 5 m at the bottom of the section and 9 m at the top, probably lived when the sea was well below its maximum extent on the terrace. This apparent difference in the sea levels under which these two faunas lived suggests that they

may not have been contemporaneous.

SUBSTRATE

Stratigraphic faunal changes also reflect a temporal change in the substrate. *Tegula gallina*, *Littorina scutulata*, *Septifer bifurcatus*, *Ostrea lurida*, and *Anomia peruviana* live only or chiefly on hard substrates, and all are very abundant in bed 1 and are either rare or absent in beds 2 and 3. On the other hand, the characteristic mudflat species *Tagelus californianus*, *Cerithidea californica*, and *Melampus olivaceus* are rare in bed 1 and increasingly abundant in beds 2 and 3. Thus the stratigraphic change in faunal composition reflects both the decrease in water depth and the change from a coarse gravel and boulder substrate to mud.

CLIMATE

Species whose present-day geographic ranges end near or do not include San Diego are listed in Table 3 with their ranges. Six species do not live today south of the San Diego-Ensenada region, and a seventh lives only as far south as Bahía San Quintín. The questionably identified *Spisula hemphilli* also lives only as far south as Ensenada. Seven species live only as far north as the San Diego-Los Angeles region. The overlapping present-day ranges of these 14 species suggest that the late Pleistocene shallow-water marine climate in which they lived was similar to that at the same latitude today.

However, the assemblage also contains several southern extralimital species, species that do not live today as far north as San Diego (Table 3). *Anachis coronata*, *Psammotreta viridotincta*, and *Chione gnidia* live only as far north as Laguna Scammon or Isla de Cedros (28° north latitude). *Eupleura muriciformis* also is reported to live today only as far north as Isla de Cedros, though Hertlein and Strong (1955: 258) included in its synonymy *Ranella triquetra* Reeve, 1844 from San Diego. Both *Eupleura muriciformis* and

Table 3. Species with geographic ranges that end near or do not include the San Diego area.

Species	Geographic Range
<i>Acmaea instabilis</i>	Alaska to San Diego (Morris, 1959: 57)
<i>Hipponix tumens</i>	Crescent City to San Diego (Oldroyd, 1927, 2 (3): 113-114)
<i>Mopalia ciliata</i>	Alaska to Bahia Todos Santos (Berry, 1922: 449-451)
<i>Epitonium indianorum</i>	Alaska to Bahia Todos Santos (Oldroyd, 1927, 2 (2): 58)
<i>Assimineia translucens</i>	Vancouver to Punta Banda (McLean, 1969: 28)
<i>Callithaca staminea</i>	Alaska to Bahia San Quintin (Grant and Gale, 1931: 329)
<i>Spisula</i> cf. <i>S. hemphilli</i>	Santa Barbara to Ensenada (McLean, 1969: 82)
<i>Cerithiopsis carpenteri</i>	San Pedro to South Coronado Island (Oldroyd, 1927, 2 (2): 253)
<i>Alabina tenuisculpta</i>	San Pedro to Magdalena Bay (Oldroyd, 1927, 2 (3): 14)
<i>Nucula</i> aff. <i>N. exigua</i>	Los Angeles to Ecuador (Burch, 1944-1946, no. 33: 7)
<i>Anadara</i> cf. <i>A. multicostata</i>	Newport Bay to Galapagos Islands (Keen, 1971: 48)
<i>Morula lugubris</i>	San Diego to Panama (Keen, 1971: 554)
<i>Pedipes liratus</i>	San Diego to Golfo de California (Oldroyd, 1927, 2 (1): 54)
<i>Crassinella branneri</i>	San Diego to Panama (Oldroyd, 1927, 1: 110)
<i>Eupleura muriciformis</i>	(San Diego ?) Isla de Cedros to Lobitos, Peru (Hertlein and Strong, 1955: 258)
<i>Anachis coronata</i>	Laguna Scammon to Ecuador (San Diego Natural History Museum Coll.)
<i>Chione gnidia</i>	Isla de Cedros to Peru (Keen, 1971: 188)
<i>Psammotreta viridotincta</i>	Laguna Scammon to Costa Rica (San Diego Natural History Museum Coll.)

THIS PAGE IS LOCKED TO FREE MEMBERS
Purchase full membership to immediately unlock this page

DELVE INTO FANTASY, MAGIC, MYTHOLOGY & FOLKLORE

Forgotten Books'
Full Membership gives
access to 797,885 ancient
and modern, fiction and
non-fiction books.

Continue

*Fair usage policy applies

- Hertlein, L. G., and A. M. Strong
1955. Marine mollusks collected during the "Askoy" expedition to Panama, Colombia, and Ecuador in 1941. *Amer. Mus. Nat. Hist., Bull.* 107: 159-318.
- Keen, A. M.
1963. Marine molluscan genera of western North America. Stanford Univ. Press, Stanford, California. 126 p.
- Keen, A. M.
1971. Sea shells of tropical west America. Second Edition, Stanford Univ. Press, Stanford, California. 1064 p.
- Kern, J. P.
1971. Paleoenvironmental analysis of a late Pleistocene estuary in southern California. *J. Paleont.* 45: 810-823.
- Kern, J. P.
Early Pliocene marine climate and environment of the eastern Ventura basin, southern California. *Univ. Calif. Pub. Geol. Sci.*, in press.
- McLean, J. H.
1969. Marine shells of southern California. *Los Angeles Co. Mus. Nat. Hist., Sci. Ser.* 24, Zool. 11. 104 p.
- Morris, P. A.
1966. A field guide to the shells of the Pacific coast and Hawaii. Houghton Mifflin, Boston. 297 p.
- Oldroyd, I. S.
1927. The marine shells of the west coast of North America. *Stanford Univ. Pub. Geol. Sci.* 1, 2 (parts 1-3).
- Ricketts, E. F., and J. Calvin
1968. *Between Pacific tides*. Fourth Edition, Stanford Univ. Press, Stanford, California. 614 p.
- Stephens, F.
1929. Notes on the marine Pleistocene deposits of San Diego County, California. *San Diego Soc. Nat. Hist., Trans.* 5: 247-255.
- Valentine, J. W.
1955. Upwelling and thermally anomalous Pacific coast Pleistocene molluscan faunas. *Amer. J. Sci.* 253: 462-474.
- Valentine, J. W.
1959. Pleistocene molluscan notes, I, The Bay Point Formation at its type locality. *J. Paleont.* 33: 685-688.
- Valentine, J. W.
1960. Habitats and sources of Pleistocene mollusks at Torrey Pines Park, California. *Ecology* 41: 161-165.
- Valentine, J. W.
1961. Paleoecologic molluscan geography of the Californian Pleistocene. *Univ. California Publ. Geol. Sci.* 34: 309-442.
- Valentine, J. W., and R. F. Meade
1961. Californian Pleistocene paleotemperatures. *Univ. California Publ. Geol. Sci.* 40: 1-46.

Department of Geology, San Diego State College, San Diego, California 92115