

# IFAE Report of Activities 2006

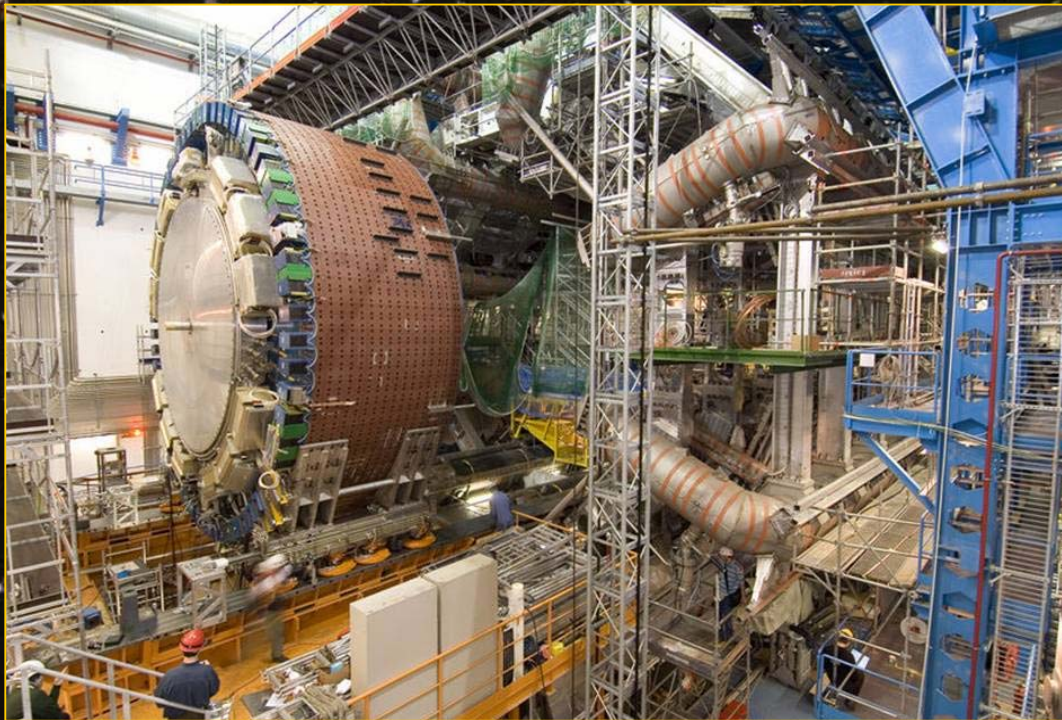

**Institut de  
Física d'Altes  
Energies**



Consorci de la Generalitat de Catalunya i de la Universitat Autònoma de Barcelona



**IFAE Report of Activities  
Year 2006**

## IFAE REPORT OF ACTIVITIES – YEAR 2006

1. Resum.....	1
2. Resumen.....	13
3. Summary.....	25
4. About IFAE.....	37
4.1. Structure.....	37
4.2. Governing board.....	38
5. IFAE personnel.....	39
6. Institutional activities.....	45
6.1. Diploma Theses .....	45
6.2. Doctoral Theses .....	45
6.3. Publications.....	46
6.4. Talks given by IFAE members.....	51
6.5. Participation in external committees.....	55
6.6. Seminars organised by IFAE.....	57
7. Scientific activities.....	61
The Experimental Division .....	61
7.1. ATLAS .....	63
7.2. The Collider Detector at Fermilab (CDF).....	71
7.3. The Neutrino Experiments at IFAE.....	77
7.4. The MAGIC Experiment.....	83
7.5. The DES (Dark Energy Survey) Project.....	87
7.6. The X-Ray Projects .....	90
The Theory Division .....	96
7.7 Quantum Information Theory .....	96
7.8 Elementary Particles in Astrophysical and Cosmological Settings.....	97
7.9 Physics of the Fundamental Interactions.....	97

# 1. RESUM

Versió en Castellà a pàgina 13

English version at page 25

En aquesta memòria es descriuen les activitats de l'Institut de Física d'Altes Energies (IFAE) en l'any 2006.

## Estructura de l'IFAE

L'IFAE és un consorci entre la Generalitat de Catalunya i la Universitat Autònoma de Barcelona (UAB). El consorci va ser creat el 16 de juliol de 1991 pel decret 159/1991 del Govern de la Generalitat. Com a tal consorci, l'IFAE és una entitat legal amb personalitat jurídica pròpia. La relació formal amb la Generalitat es porta a terme a través del Departament d'Universitats, Reserca i Societat de l'Informació (DURSI). L'IFAE integra el seu propi personal amb personal dels Grups de Física Teòrica i de Física d'Altes Energies del Departament de Física de la UAB. La llista del personal apareix en la pàgina 39.

Els òrgans de govern de l'Institut són el Consell de Govern i el Director. Les línies generals d'investigació, la contractació de personal, el pressupost anual i la creació i la supressió de Divisions són algunes de les responsabilitats del Consell de Govern, el qual també designa al Director a partir d'una llista de candidats proposats pel rector de la UAB. El Director és responsable de l'execució de les decisions del Consell de Govern. Els Coordinadors de les Divisions són proposats pel director i designats pel Consell de Govern. Els membres del Consell de Govern durant 2006 figuren en la pàgina 38.

L'IFAE té també l'estatut d'Institut Universitari adscrit a la UAB. Aquesta fórmula permet al personal de l'IFAE participar en el programa docent de la UAB, en particular en els cursos de doctorat.

En 2004 l'IFAE es va unir a les seves institucions fundacionals, la UAB i el DURSI, així com al CIEMAT (Centre d'Investigacions Energètiques i Mediambientals, una organització d'investigació de caràcter estatal amb seu a Madrid), per a crear i promoure el Port d'Informació Científica (PIC). Aquest centre, situat en el campus de la UAB, molt a prop de l'IFAE, té com objectiu donar suport a projectes científics que requereixin l'accés distribuït a enormes quantitats de dades, tals com els futurs experiments en l'accelerador LHC del CERN. L'IFAE ha estat encarregat de la gestió administrativa del PIC per les altres institucions que formen el consorci. El PIC té el seu propi Director i Consell de Govern. Les activitats del PIC es descriuen a les seves pròpies memòries.

## Objectius de l'IFAE

Tal com figura en el Decret 159/1991 del Govern de la Generalitat de Catalunya, l'objectiu de l'IFAE és realitzar investigació i contribuir al desenvolupament de la Física d'Altes Energies, tant en la seva vessant teòrica com experimental.

Els orígens del consorci estan en el Departament de Física Teòrica i en el Laboratori de Física d'Altes Energies (LFAE) de la UAB. El grup teòric va ser establert al 1971, quan es va crear la universitat. El Laboratori de Física d'Altes Energies va ser creat al 1984, amb l'objectiu d'iniciar la investigació en aquesta disciplina a la UAB, en particular per a aprofitar de manera eficaç la pertinença al laboratori internacional CERN, després que Espanya va tornar a formar part del mateix al 1982. Com es menciona en el Decret 159/1991, l'existència del LFAE i de grups d'investigació teòrics a Catalunya, el desig de reforçar la investigació de la Física d'Altes Energies, en particular en la vessant experimental, i el desig de col·laborar en l'esforç del Govern espanyol per a desenvolupar aquest

camp, va conduir a les autoritats de la Generalitat a crear l'IFAE al 1991.

En els anys següents la divisió experimental de l'IFAE va passar de un personal de 15 a aproximadament 65 persones. El programa experimental s'ha també ampliat, tant en el nombre de projectes com en la seva temàtica. Al 1992 el grup estava involucrat en un experiment en física de partícules, l'experiment ALEPH de l'accelerador LEP del CERN, mentre que actualment hi ha quatre línies d'investigació diferents: física de partícules en col·lisionadors, amb ATLAS i CDF, física de neutrins, amb K2K i T2K, astrofísica d'altres energies, amb MAGIC, i física aplicada, amb el projecte de RAIGS-X. Al 2005 també es van assegurar les bases per a una línia en cosmologia observacional amb el projecte DES (Dark Energy Survey) descrit més endavant. A més existeix una col·laboració molt estreta amb el Port d'Informació Científica (PIC) en els aspectes computacionals dels experiments. La Divisió Teòrica ha ampliat també el seu programa d'investigació des que l'IFAE va ser creat. A l'actualitat hi ha tres línies principals d'investigació: física de les interaccions fonamentals, astrofísica d'altres energies i informació quàntica.

El fet que l'IFAE tingui personalitat jurídica pròpia li ha permès assumir la gestió dels seus propis projectes així com d'alguns projectes externs.

Des del 1995 al 2001 el Laboratori de Llum Sincrotró (LLS) va estar administrativament dintre de l'IFAE. Aquest laboratori va ser l'organització que va proposar la construcció d'una Font de Llum de Sincrotró a Barcelona, un projecte aprovat tant pel govern espanyol a Madrid com pel govern de Catalunya al 2003, ara en construcció.

L'IFAE va ser també la institució responsable de la construcció de l'edifici de MAGIC al Roque

de los Muchachos a l'Illa de La Palma i és a l'actualitat la institució responsable dels "Fons Comúns" (les despeses de funcionament i operació) de MAGIC.

Des del 1999 l'IFAE ha estat també la institució responsable del seguiment, tant tècnic com administratiu, d'un contracte entre el CERN i una empresa espanyola, per a la construcció de recipients de buit de l'Imant Toroidal del detector ATLAS, tal com s'explica més endavant en aquest capítol.

Una breu descripció dels projectes d'investigació de l'IFAE a les Divisions Experimental i Teòrica, apareix a continuació. Al capítol 7 es troben descripcions més detallades.

## **1.1 La Divisió Experimental al 2006.**

Durant 2006 la Divisió Experimental va continuar la seva participació en sis projectes principals: ATLAS, un experiment en preparació pel futur accelerador LHC del Centre Europeu per a la Física de Partícules (CERN); CDF, un experiment de col·lisions antiprotó-protó que es porta a terme en el Laboratori Nacional de Fermi (FNAL), a Illinois, EE. UU; K2K i T2K, dos experiments d'interaccions de neutrins que està tenint lloc al Japó; MAGIC, un experiment d'astrofísica de partícules que està prenent dades a les Illes Canàries; DES, que construeix un telescopi per a observar uns 300 milions de galàxies, a l'hemisferi sud, per a estudis de cosmologia; i DearMama, un projecte finançat per la Unió Europea que ha desenvolupat una càmera digital de raigs-X d'alta resolució i contrast i amb una dosi de radiació baixa.

A més el grup de neutrins de l'IFAE està estudiant un possible experiment que tindria lloc al Laboratori Subterrani de Canfranc, a prop de Jaca.

## ATLAS

Durant les últimes dècades del segle XX la Física de Partícules ha arribat a una síntesi global a la qual es coneix com Model Estàndard, o SM. El SM descriu amb extraordinària precisió tres de les interaccions fonamentals entre components elementals de la matèria en termes de teories quàntiques de camp: les interaccions fortes, febles i electromagnètiques. Cap resultat experimental, amb excepció de les masses no nul·les dels neutrins, que es suposen zero en el model, està en contradicció seriosa amb la teoria. En particular, la generació d'experiments fets en col·lisionadors d'electrons i positrons, tals com l'accelerador LEP del CERN, ha sotmès al model a proves rigoroses.

Però a pesar de l'enorme èxit, el Model Estàndard no és una teoria completa, doncs deixa sense resposta diverses preguntes fonamentals. El consens, que ha anat en augment durant els últims anys, és que la millor manera d'anar "més enllà del Model Estàndard" és estudiar les col·lisions entre components fonamentals de la matèria a energies molt altes. Aquest és de fet l'objectiu principal del Large Hadron Collider (LHC), l'accelerador construït al CERN en el qual es faran col·lisionar protons contra protons a una energia total de 14 TeV, la més alta assolida al laboratori fins ara.

L'IFAE participa de manera important en el projecte ATLAS, un dels dos experiments amb objectius generals que es portaran a terme al LHC. El detector ATLAS és un aparell molt complex, construït en dotzenes de laboratoris en el món sencer. L'IFAE va ser un dels centres en els quals es va ensamblar un dels subdetectors més grans de ATLAS, el Calorímetre Hadrònic conegut com TileCal (para Tile Calorimeter). Aquest subdetector consisteix en tres "barrils", cadascun fet de 64 mòduls. A la primavera del 2002 l'IFAE va completar la producció a Barcelona d'un barril complet (64 mòduls, cadascun amb un pes de 12 tones, a més d'un de recanvi), una tasca que va començar al 1999. L'IFAE també va dissenyar i va fabricar l'electrònica de calibració de TileCal (11,000 canals d'amplificació i 370 circuits de conversió analògica-digital), la producció de la qual va ser acabada al 2004. El calorímetre hadrònic va ser el primer detector instal·lat en la caverna experimental de ATLAS, al 2005. Una vegada allí es van realitzar extenses proves dels sistemes de lectura electrònica i de calibració, en els quals el grup de l'IFAE va participar i segueix participant amb un paper destacat. En la figura s'ensenya un raig còsmic detectat en TileCal i en altres detectors de ATLAS al 2006

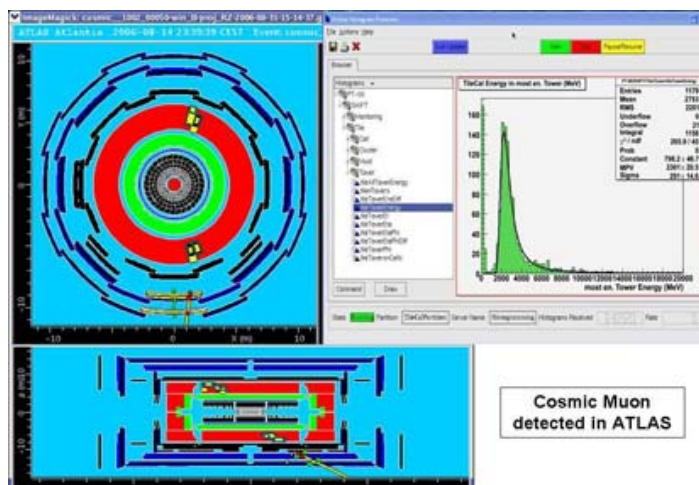

Un raig còsmic passant pel detector tal com es visualitza a ATLAS (esquerra); energia dipositada per muons còsmics a TileCal (dreta).

A més d'aquest treball sobre el propi detector, l'IFAE està força involucrat en altres aspectes de l'experiment ATLAS, entre ells :

a) Participació en l'anàlisi de les dades preses amb feixos de prova dels mòduls del calorímetre.

b) Implementació dels algorismes de Flux de Dades ("Dataflow") i de les Tasques de Processat (PT, sigles de "Processing Tasks") del Filtre de Successos ("Event Filter"). El Event Filter és un conjunt de codis que selecciona dades per a un ulterior anàlisi. El Dataflow és un component estructural crucial del Event Filter, mentre que el PT serveix com interfície i executa les tasques de selecció de successos.

L'IFAE és responsable d'aquests dos components. Al 2006, el treball de selecció de successos es va enfocar en les prestacions del

sistema a seleccionar successos amb Taus, un senyal de nous processos no previstos pel SM.

c) Preparació de l'anàlisi de canals de descoberta, estudiant la simulació de reaccions de fons que necessiten un enteniment en profunditat – també pel seu interès intrínsec. Més detalls d'aquests estudis és donen més a baix.

d) Preparació de la infraestructura de càlcul necessària per a l'experiment, descrita més a baix.

e) El seguiment, administratiu i tècnic, del contracte entre el CERN i una empresa espanyola, per a la fabricació dels 8 recipients de buit de 25m x 5m que alberguen les bobines de l'Imant Toroidal. En la figura s'ensenya aquest imant, completament instal·lat en la caverna de ATLAS, al costat del barril de TileCal construït a l'IFAE.



*Una vista de la caverna de ATLAS al març del 2006. El "barril" de TileCal construït a IFAE és el cilindre marró a l'esquerra, i s'està col·locant dintre dels recipients de buit de l'imant toroidal, fabricats a Espanya. Dos dels recipients es veuen a la dreta (amb tires marrons); els recipients s'alberguen les bobines superconductoras de l'imant.*



## CDF

L'experiment CDF és en molts aspectes un precursor de ATLAS. L'experiment té lloc en el col·lisionador dit Tevatron, situat al Laboratori Nacional Fermi d'Estats Units, a Illinois. En el Tevatron, feixos de protons i antiprotons xoquen amb una energia total en el centre de masses de 2 TeV. CDF ha anat prenent dades des dels primers anys noranta, obtenint diversos importants resultats, entre ells la descoberta del quark *top* al 1995. Considerables modernitzacions del col·lisionador i de CDF es van realitzar al principi de la dècada i ja estan funcionant a ple rendiment.

Els objectius de física són semblants als del LHC. Encara que potser l'energia dels feixos no sigui suficient per a detectar fenòmens més enllà del SM, l'augment de lluminositat durà a mesures rellevants i potser altres descobertes en un proper futur. No obstant això, el Tevatron continua sent l'accelerador de més alta energia en el món.

El grup de l'IFAE manté una forta presència en el funcionament de CDF, havent creat un sistema (dit DQM) per a monitoritzar la qualitat de les dades en temps real. Fins al 2006, el grup ha portat a terme diverses anàlisis de processos físics, que s'han concretat en diverses publicacions i 16 ponències en tallers i conferències. Una recerca de la SuperSimetría – un dels escenaris de nova física teòricament més atractius – ha ampliat significativament els límits sobre la massa d'unes partícules supersimètriques (*squarks* i *gluins*). Investigant les fronteres del SM, s'han mesurat les seccions eficaces inclusives de *jets* hadrònics sobre 7 ordres de magnitud, fins a energies transverses de 700 GeV, com es veu en la figura.

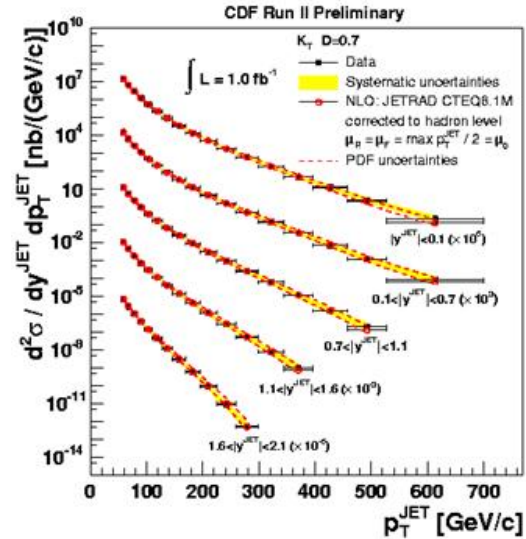

Seccions eficaces inclusives de jets, amidades amb l'algorisme  $k_T$ .

## EXPERIMENTS amb NEUTRINS

En l'experiment K2K sobre oscil·lacions de neutrins un feix d'aquestes partícules, produït en el laboratori KEK del Japó, és enviat al laboratori Kamioka, situat a 250 quilòmetres de distància. Els neutrins viatgen per la terra amb una atenuació insignificant. L'experiment amida el flux de neutrins de tipus muònic en dues posicions diferents: prop de la font on són produïts, en el propi laboratori KEK, i a 250 quilòmetres de distància a Kamioka, en la part occidental del Japó. Per a aquest propòsit l'experiment té dos detectors: un a 200 m del punt de producció dels neutrins, i altre més llunyà a Kamioka, el detector Super-Kamiokande. Aquest consisteix en un enorme tanc (50,000 tones) d'aigua molt pura. El flux es mesura comptant el nombre d'interaccions quasi-elàstiques de neutrins muònics en un volum donat d'ambdós detectors. Les mesures en el detector proper són extrapolades al detector llunyà i comparades amb el que és realment amidat allí. La presa de dades va finalitzar al novembre del 2004, i l'anàlisi dels resultats sobre oscil·lacions es va publicar al 2005 [E. Aliu et al., Phys. Rev. Lett. 94:081802, (2005)].

En la figura es mostra la distribució d'energia dels successos gairebé-elàstics (muons) en

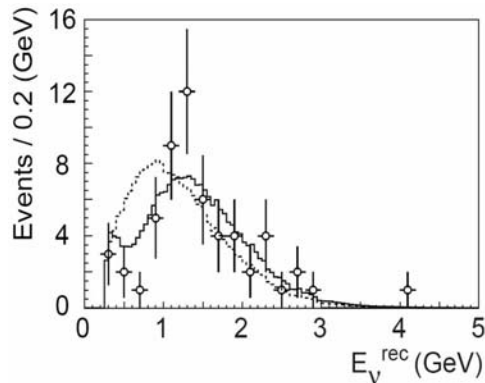

*L'energia reconstruïda dels successos amb un muó en SuperKamiokande.*

Superkamiokande, comparada amb l'esperat en absència d'oscil·lacions (línia de punts) i amb oscil·lacions (línia sòlida). El millor ajustament a les dades dona com resultat els paràmetres  $(\sin^2 2\theta, m^2) = (1.0, 2.8 \times 10^{-3} \text{ eV}^2)$ . Amb aquests paràmetres el nombre esperat de successos gairebé-elàstics és de 103.8, en acord als 107 observats i no amb el nombre esperat en absència d'oscil·lacions:  $151 \pm 11$ . Aquest resultat confirma, en un experiment controlat, la interpretació dels resultats del 1998 de Super-Kamiokande. L'IFAE també participa a T2K, un experiment de neutrins de segona generació. A T2K un feix de neutrins molt més intens, produït en el nou accelerador JPARC que s'està construint a Tokai, serà enviat a Super-Kamiokande, a 300 km de distància. El treball de l'IFAE s'ha enfocat en el detector proper, un espectròmetre a 280 m del blanc de producció de neutrins. S'utilitzarà un gran imant de baix camp (0.2 T, veure següent figura). Les partícules carregades es detectaran amb una "Time Projection Chamber" (TPC).

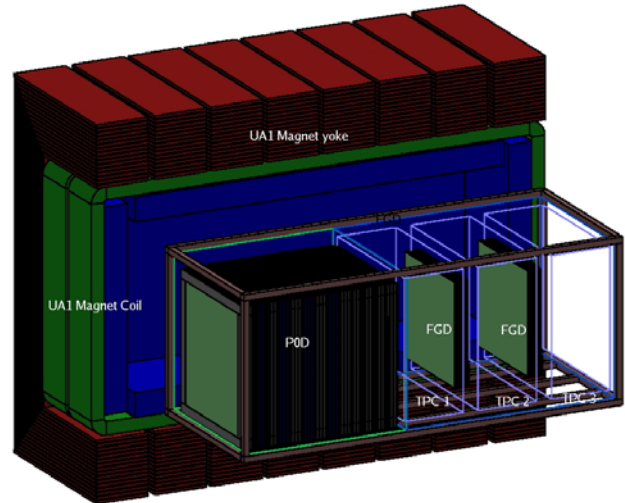

*Vista en secció del espectròmetre de T2K, a 280 m del punt de producció dels neutrins. El feix entra en el detector per l'esquerra.*

L'objectiu principal de T2K és observar les transformacions de neutrins muònics a neutrins electrònics, la qual donarà informació sobre un paràmetre encara desconegut de les oscil·lacions. L'IFAE ha donat moltes aportacions al disseny del detector i a les proves, que han dut a escollir el detector que llegirà la TPC, dit MicroMegas. Els prototips del detector s'han provat amb raigs còsmics en la TPC de l'experiment HARP en el CERN, al 2005 i 2006 (veure figura).



*Muntatge en el CERN: el prototip de lectura dintre de l'imant (verd) i de la caixa electrostàtica de HARP (alumini).*

El primer prototip de tota la TPC de T2K estarà complet i en marxa a la fi de 2007, per a tenir tot el detector instal·lat a Tokai al 2009 .

El grup IFAE està també involucrat en un projecte que es podria posar en marxa en la nova sala experimental del Laboratori Subterrani de Canfranc (LSC). La profunditat del laboratori – que minimitza els fons de raigs còsmics - i l'àrea disponible atorguen oportunitats excitants de llançar en LSC un nova generació d'experiments sobre la desintegració nuclear amb dos electrons i sense neutrins. Aquests processos són summament infreqüents, no obstant això si es revelessin de forma certa serían uns resultats de gran transcendència sobre la naturalesa dels neutrins.

## MAGIC

MAGIC és l'acrònim de Major Atmospheric Gamma-Ray Imaging Telescope. El telescopi està situat en l'Observatori del Roque de los Muchachos (ORM) a la Illa de la Palma de les Canàries (28.8N, 17.9W, altitud 2200m). L'objectiu de l'experiment és l'estudi dels raigs gamma de molt alta energia que arriben a la Terra d'un nombre relativament petit de fonts. Aquests ens donen informació sobre els mecanismes que produeixen tal radiació, que figuren entre els més violents que es coneixin en el cosmos. Per altra banda la propagació de la radiació en distàncies cosmològiques és sensible a la geometria i al contingut en matèria del propi

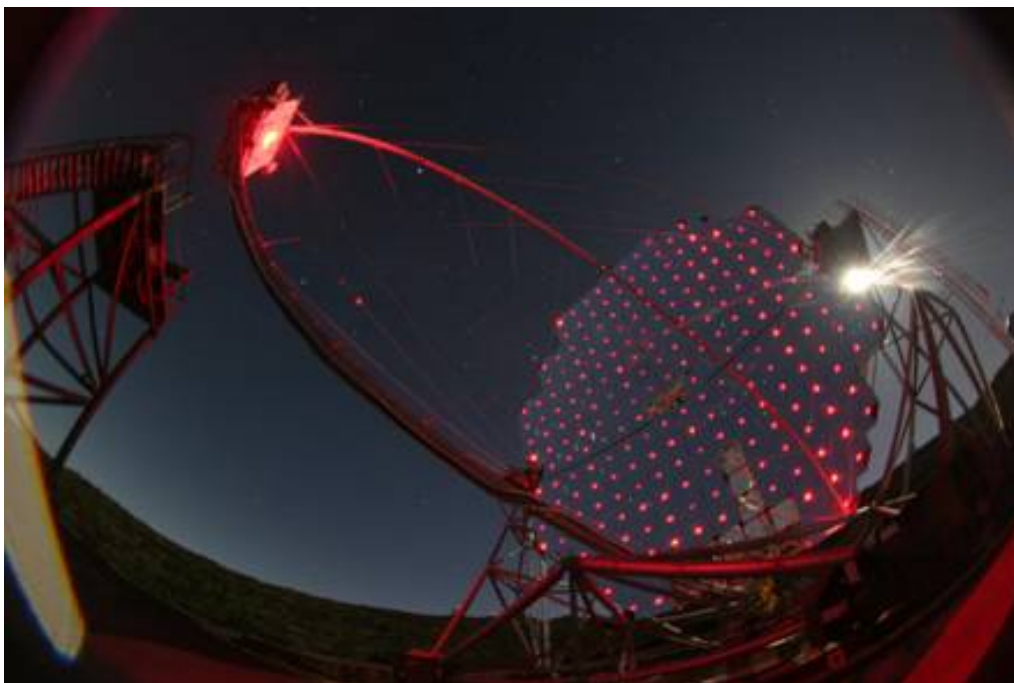

*Foto del telescopi durant el funcionament del sistema per a l'enfocament dels miralls, basat en feixos laser de referència.*

cosmos. MAGIC observa la llum induïda per les interaccions dels raigs gamma entrants amb la part superior de l'atmosfera. Aquesta llum és reflectida en un mirall segmentat de 17m de diàmetre i és recollida per la càmera, localitzada

en el focus. La càmera conté de fotodetectores molt ràpids i sensibles.

El grup de l'IFAE va construir en la seva totalitat la càmera del telescopi i el seu sistema

de control, així com l'edifici que allotja l'electrònica i els equips de presa de dades. A més és responsable del control general del telescopi.

El telescopi va ser inaugurat a l'octubre del 2003 i va ser posat a punt al llarg del 2004. A la fi del 2006, els dos primers anys d'observacions havien produït 14 articles (publicats o acceptats per les revistes) molts dels quals havien estat iniciats pels físics de l'IFAE, o havien rebut contribucions importants per la seva banda. Quatre tesis de doctorat es van completar durant aquest període.

Resumint el més destacat de les observacions del 2005 i 2006:

- la detecció d'emissió variable per una estrella binària de raig X va ser un resultat nou, que es va traduir en un article en la revista Science.

- Es va observar l'espectre de raigs gamma pel centre galàctic, el que va permetre posar límits molt restrictius sobre els paràmetres de la matèria fosca en la nostra galàxia.

- durant la campanya del 2006 es van observar diversos Nuclis Galàctics Actius (AGN). Es va descobrir un nou AGN (Mrk 180) i es va observar variació molt ràpida, en l'escala de minuts, durant un esclat de Mrk 501. Aquest fenomen va permetre buscar una correlació entre l'energia dels raigs gamma i els seus temps d'arribada, cosa que s'espera si hi ha ruptura de la invariància de Lorentz a causa de fenòmens de Gravetat Quàntica. Els resultats de Magic posen límits estrictes a aquestes teories.



*Els dos telescopis MAGIC al novembre del 2006. El més proper és MAGIC-II, durant la instal·lació de les components principals en el moment de prendre la foto.*

Al 2004 la col·laboració va començar un programa per a construir un segon telescopi, semblat a MAGIC, que funcionarà juntament

amb el primer, realitzant així els següents objectius:

(i) millorar les resolucions espectral i angular, així com la supressió del soroll, incrementant la sensibilitat en un factor 2, ii) com a conseqüència, un increment del temps efectiu d'observació en un factor 4, iii) reducció del llinar d'observació en energia sense interrupció en les observacions, i (iv) servir com banc de proves per a desenvolupaments futurs. MAGIC-II utilitza nous fotosensors i una electrònica de digitalització més ràpida (amb mostres a 2-4 GHz). A la fi del 2006, la major part de la instrumentació pesada de MAGIC-II estava ja instal·lada (veure figura anterior) i es planejava que components importants es lliuressin al 2007, per a la posta en marxa al 2008 .

## EL PROJECTE DES (Dark Energy Survey)

Al 2005 un equip de l'IFAE, juntament amb equips del IEEC (Institut de Estudis Espacials de Catalunya) i del CIEMAT (Centre d'Estudis Energètics Mediambientals i Tecnològics) de Madrid, va començar un nou programa de Cosmologia Observacional, entrant en una col·laboració fins a llavors principalment anglo-americana, DES (Dark Energy Survey). El propòsit de la col·laboració és catalogar i mesurar l'espectre d'un gran nombre de galàxies (uns 300 milions) i cúmuls de galàxies en una zona de 5000 graus quadrats de l'hemisferi sud, en quatre bandes òptiques. El programa té un objectiu ambiciós, fitar l'equació d'estat de l'univers, amidant simultàniament diversos paràmetres cosmològics .

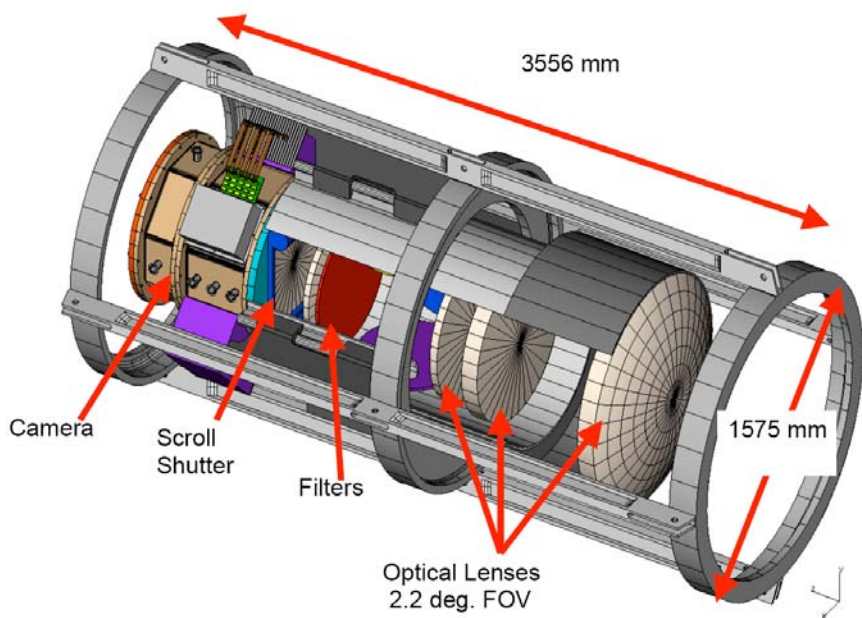

*Disseny de DECam, la càmera de DES que s'està construint .*

També s'observarà repetidament una zona del cel (de 40 graus<sup>2</sup>) amb l'objectiu de descobrir i mesurar l'espectre fotomètric d'unes 1900

supernoves de tipus Ia, en un rang de  $z$  (corriment cap al vermell),  $0.3 < z < 0.75$ .

La col·laboració DES està construint una càmera CCD de gran angle (3 graus<sup>2</sup>), que anirà situada en el focus principal del telescopi Blanco, de 4m de diàmetre, situat en el Cerro Tololo de Xile. A canvi la col·laboració obté un 30% de tot el temps d'observació. Aquest telescopi forma part de l'organització NOAO (National Optical Astronomy Observatory) de EE. UU., finançada per la NSF. NOAO va fer una convocatòria de projectes per a equipar al telescopi Blanco amb un nou instrument, i el projecte triat fou el que va presentar DES. Els tres grups espanyols seran finançats pel Programa Nacional d'Astronomia i Astrofísica.

La figura anterior mostra el disseny de la càmera de DES (denominada DECam), que tindrà 519 megapíxels de CCDs d'un nou disseny, més eficients en la zona del vermell i del proper infraroig de l'espectre que els anteriors. Per la seva grandària, aquesta càmera representarà una nova fita en astronomia òptica.

Els grups espanyols estan involucrats en el disseny i la fabricació de l'electrònica de lectura dels píxels i dels seus controls. El grup IFAE té un paper central en aquesta activitat, per haver construït i engegat, al 2006, un banc de prova de l'electrònica, amb criogenia, que permetrà a més fer estudis fotomètrics de la resposta dels píxels. Les activitats de IFAE i dels grups espanyols es descriuen en més detall més endavant.

Pels aspectes científics, el grup IFAE està molt involucrat en el programa sobre les Supernoves Ia com a sondes de l'Energia Fosca, i en la preparació de l'anàlisi de les dades. A més el grup participa en altres propostes de projectes futurs, com es descriu més a baix.

### **PROYECTE de DETECTOR de RAIGS-X**

L'Institut persegueix molt activament una línia d'investigació aplicada en detectors amb finalitats mèdiques, en concret, el desenvolupament d'una càmera digital de raigs-X per a obtenir una imatge d'alta qualitat amb una dosi molt baixa de radiació. El detector està pensat per a mamografia i està basat a detectar

els raigs-X amb un semiconductor d'alta densitat. L'eficiència de conversió de raigs-X del material permet produir imatges d'alta qualitat amb dosi de radiació molt reduïdes en comparació de la radiografia convencional.

En física d'altres energies, detectors en semiconductors s'han anat utilitzant per molts anys. La presència en IFAE de personal tècnic i científic amb coneixement d'aquestes tècniques ens ha permès afrontar un projecte d'aquestes característiques.

L'IFAE va presentar a la Unió Europea un projecte d'investigació en aquesta línia, com a coordinador de 6 instituts europeus. Els altres instituts espanyols inclouen El Centre Nacional de Microelectrònica (CNM), que també està en el campus de la UAB, i l'Hospital Parc Taulí de Sabadell. El projecte, amb les sigles de DearMama, va ser aprovat a la fi del 2000. L'objectiu principal era produir un prototip complet de detector per a l'ús en mamografies. L'objectiu es va assolir. Un sistema de radiografies es va engegar al 2005 i va ser sotmès a proves clíniques al 2006. L'equip del Dr. M. Sentis va conduir les proves.



*Una infermera muntant un a mostra de "lumpectomia" en Dear-Mama-I en l'Hospital Parc Taulí*

En la figura anterior es veu la màquina Dear-Mama-I en la qual s'ha muntat una mostra histològica. Els resultats es donen més baix en aquesta memòria.

El projecte de l'Unió Europea es va allargar fins al setembre del 2006 per a efectuar proves més completes. Aquest terme va encaixar amb el pla d'una segona màquina de raigs-X, basada en un ulterior desenvolupament de la tecnologia del detector, que també es va construir al 2006. Coneguda com Dear-Mama-II, aquesta màquina és dedicada a les radiografies òssies, i utilitza un detector de píxels de CdTe llegit per una electrònica que conta els fotons.

La major densitat del detector de CdTe permet l'ús de dosi de radiació encara més baixes amb les mateixes o millors prestacions en termes de resolució i contrast de la imatge. Més resultats i comparances es donen en el capítol 7 de la memòria.

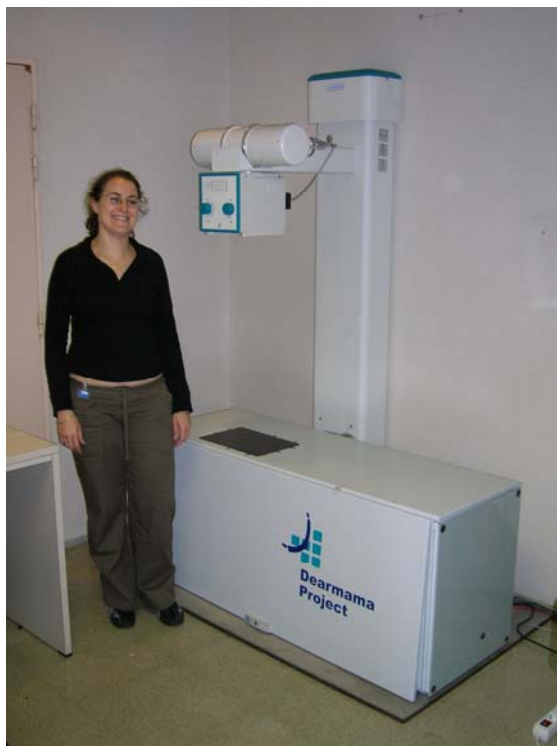

*La màquina Dear-Mama-II de radiografia òssia, completa, instal·lada i llesta per a l'ús en UDIAT (Hospital de Parc Taulí).*

Aquest treball ha generat una patent en USA i continua en una empresa de spin-of, X-ray Imatek SL, creada al 2006 amb l'estímul i el suport de la Generalitat.

## 1.2 La Divisió Teòrica al 2006

L'activitat de la Divisió de Teoria pot ser classificada en tres línies principals d'investigació: informació quàntica, astrofísica de partícules i física de les interaccions fonamentals.

### Informació Quàntica

La Informació Quàntica és un àrea d'investigació multidisciplinar en la qual la física quàntica s'ajunta amb camps tan diferents com l'estadística matemàtica, la criptografia, la informàtica i la nanotecnologia, entre uns altres. La informació quàntica utilitza les lleis de la mecànica quàntica, és a dir, les lleis del món microscòpic, per a efectuar eficientment certes tasques de computació que no admeten tractament dintre de la física clàssica i dels ordinadors actuals .

El Grup d'Informació Quàntica (GIQ) ajunta investigadors adscrits a la UAB, el treball dels quals s'enfoca principalment en el camp de la informació quàntica i el "entanglement". El GIQ no és una entitat oficialment reconeguda, no obstant això inclou tots els participants en els projectes QUIRT I i II (Quantum Information and Related Topics) finançats pel MEC i per la Xarxa Temàtica Europea QUPRODIS IST2002.

### Astrofísica de Partícules

És generalment reconegut que aquest camp, conegut també com astropartícules o cosmologia de partícules, es troba en una fase de ràpida expansió. Les oscil·lacions de neutrins, detectades en experiments de neutrins

atmosfèrics i solars, constitueixen una descoberta de gran transcendència per a la física dels neutrins, un camp en el qual el grup de l'IFAE ha anat treballant molts anys.

El nostre treball es caracteritza per l'estudi d'aspectes teòrics de la física de les partícules elementals i les seves interaccions, especialment en un ambient astrofísic o cosmològic. En aquests mitjans es verifiquen processos físics que estan suprimits en el laboratori, o bé es concreten d'altres maneres.

### **Física de les interaccions fonamentals**

A pesar dels seus èxits, hi ha moltes indicacions que el SM no pot ser complet. Hi ha proves experimentals que els neutrins tenen massa (encara que no se sàpiga de quin tipus). A més sabem que l'asimetria entre partícules i antipartícules en l'univers no es pot explicar en el SM, perquè en això no hi ha bastant violació de CP. I finalment, la gravetat àdhuc es resisteix a tots els intents de quantització, al contrari de les altres interaccions fonamentals.

És molt probable que els experiments en el LHC revelin les respostes a unes d'aquestes preguntes. El nostre grup es dedica a l'estudi de la física en l'escala electrofeble, de l'origen de les masses i d'importants simetries discretes com CP. En això, tant conceptes com la SuperSimetria, Dimensions Extra o la recent "Unparticle Physics", com la Física de Precisió del Sabor o les Interaccions Fortes No-Perturbatives juguen un paper important. I finalment, pensem que és important conèixer les implicacions per a la física de partícules de models de cosmologia i astrofísica.



## **2. RESUMEN**

**Versió en Català en pàgina 1.**

**English version on page 25**

En esta memoria se describen las actividades del Instituto de Física de Altas Energías (IFAE) en el año 2006.

### **Estructura del IFAE**

El IFAE es un consorcio entre la Generalidad de Cataluña y la Universidad Autónoma de Barcelona (UAB), creado el 16 de julio de 1991 por el Decreto 159/1991 del Gobierno de la Generalidad. Como tal consorcio, el IFAE es una entidad legal con personalidad jurídica propia. La relación formal con la Generalidad se lleva a cabo a través del Departamento de Universidades, Investigación y Sociedad de la Información (DURSI). El IFAE integra su propio personal con personal de los Grupos de Física Teórica y de Física de Altas Energías del Departamento de Física de la UAB. La lista del personal aparece en la página 39.

Los órganos de gobierno del Instituto son el Consejo de Gobierno y el Director. Las líneas generales de investigación, la contratación de personal, el presupuesto anual y la creación y la supresión de Divisiones son algunas de las responsabilidades del Consejo de Gobierno, el cual también designa al Director a partir de una lista de candidatos propuestos por el Rector de la UAB. El Director es responsable de la ejecución de las decisiones del Consejo de Gobierno. Los Coordinadores de las Divisiones son propuestos por el Director y designados por el Consejo de Gobierno. Los miembros del Consejo de Gobierno durante 2006 figuran en la página 38.

El IFAE tiene también el estatuto de Instituto Universitario adscrito a la UAB, una fórmula que permite al personal del IFAE participar en el programa docente de la Universidad, en particular en los cursos doctorales.

En 2004 el IFAE se unió a sus instituciones fundacionales, la UAB y el DURSI, así como al CIEMAT (Centro de Investigaciones Energéticas y Medioambientales, una organización de investigación de carácter estatal con sede en Madrid), para crear y promover el Puerto de Información Científica (PIC). Este centro, situado en el campus de la UAB, muy cerca del IFAE, tiene como objetivo dar apoyo a proyectos científicos que requieran el acceso distribuido a enormes cantidades de datos, tales como los futuros experimentos en el acelerador LHC del CERN. El IFAE ha sido encargado de la gestión administrativa del PIC por las otras instituciones firmantes del acuerdo. El PIC tiene su propio Director y Consejo de Gobierno. Las actividades del PIC están descritas en sus memorias.

### **Objetivos de IFAE**

Tal como figura en la Orden 159/1991 del Gobierno de la Generalitat de Cataluña, el objetivo del IFAE es realizar investigación y contribuir al desarrollo tanto de la Física de de Altas Energías, tanto en su vertiente teórica como experimental.

Los orígenes del consorcio están en el Departamento de Física Teórica y en el Laboratorio de Física de Altas Energías (LFAE) de la UAB. El grupo teórico fue establecido en 1971, cuando se creó la universidad. El Laboratorio de Física de de Altas Energías fue creado en 1984, con el objetivo de iniciar la investigación en esta disciplina en la UAB, en particular para aprovechar de manera eficaz los retornos de la pertenencia al laboratorio internacional CERN, después de que España volvió a formar parte del mismo en 1982. Como menciona en el Decreto 159/1991, la existencia del LFAE y de grupos de investigación teóricos en Cataluña, el deseo de reforzar la investigación Física de Altas Energías, en particular en la vertiente experimental, y el deseo de colaborar en el esfuerzo del Gobierno español para desarrollar este campo, llevó a las

autoridades de la Generalitat a crear el IFAE en 1991.

En los años siguientes la división experimental del IFAE pasó de 15 personas al personal actual consistente en aproximadamente 65 personas. El programa experimental se ha también ampliado, tanto en el número de proyectos como en su temática. En 1992 el grupo estaba involucrado fundamentalmente en un experimento en física de partículas, el experimento ALEPH del acelerador LEP del CERN, mientras que actualmente hay cuatro líneas de investigación distintas: física de partículas en colisionadores, con ATLAS y CDF, física de neutrinos, con K2K y T2K, astrofísica de altas energías, con MAGIC, y física aplicada, con el proyecto de Rayos-X. En 2006, se reforzó una línea en cosmología observacional, iniciada en 2005 con el proyecto DES (Dark Energy Survey). Además existe una colaboración muy estrecha con el PIC, en los aspectos computacionales de los experimentos.

La División Teórica ha ampliado también su programa de investigación desde que el IFAE fue creado. En la actualidad hay tres líneas principales de investigación: física de las interacciones fundamentales, astrofísica de altas energías e información cuántica.

El que el IFAE tenga personalidad jurídica propia le ha permitido asumir la gestión de sus propios proyectos así como de algunos proyectos externos.

Desde 1995 a 2001 el Laboratorio de Luz Sincrotrón (LLS) estuvo administrativamente dentro del IFAE. El LLS fue la organización que propuso la construcción de una Fuente de Luz de Sincrotrón en Barcelona, un proyecto aprobado tanto por el Gobierno español en Madrid como por el Gobierno de Cataluña en 2003, ahora en construcción.

El IFAE fue también la institución responsable de la construcción del edificio de MAGIC en el Roque de los Muchachos en la Isla de La Palma

y es en la actualidad la institución responsable del "Fondo Común" (los gastos de funcionamiento y operación) del experimento MAGIC.

Desde 1999 el IFAE ha sido también la institución responsable del seguimiento, tanto técnico como administrativo, de un contrato entre el CERN y una empresa española, para la construcción de vasijas de vacío del Imán Toroidal del detector ATLAS, tal como se explica más adelante en este capítulo.

A continuación, aparece una breve descripción de los proyectos de investigación del IFAE, en las Divisiones Experimental y Teórica. Una descripción más detallada aparece en el capítulo 7.

## **2.1 La División Experimental en 2006.**

Durante 2006 la División Experimental continuó su participación en seis proyectos principales: ATLAS, un experimento en preparación para el futuro acelerador LHC del Centro Europeo para la Física de Partículas (CERN); CDF, un experimento de colisiones antiprotón-protón que se lleva a cabo en Laboratorio Nacional de Fermi (FNAL), en Illinois, EE. UU; K2K y T2K, dos experimentos de interacciones de neutrinos que tienen lugar en Japón; MAGIC, un experimento de astrofísica de partículas actualmente tomando datos en las Islas Canarias; DES, construyendo un telescopio para observar unos 300 millones de galaxias, en el hemisferio sur, para estudios de cosmología; y DearMama, un proyecto financiado por la Unión Europea que ha desarrollado una cámara digital de rayos-X de alta resolución y contraste y con una dosis de radiación baja.

Además el grupo de neutrinos del IFAE está estudiando un posible experimento que tendría lugar en el Laboratorio Subterráneo de Canfranc, cerca de Jaca.

## ATLAS

Durante las últimas décadas del siglo XX la Física de Partículas ha llegado a una síntesis global a la cual se conoce como Modelo Estándar, o SM. El SM describe con extraordinaria precisión tres de las interacciones fundamentales entre componentes elementales de la materia en términos de teorías cuánticas de campo: las interacciones fuertes, débiles y electromagnéticas. Ningún resultado experimental, con excepción de las masas no nulas de los neutrinos, que se suponen cero en el modelo, está en contradicción seria con la teoría. La generación de experimentos hechos en colisionadores de electrones y positrones, tales como el acelerador LEP del CERN, ha sometido al modelo a pruebas rigurosas.

Pero a pesar del enorme éxito, el Modelo Estándar no es una teoría completa, pues deja sin respuesta varias preguntas fundamentales. El consenso, que ha ido en aumento durante los últimos años, es que el mejor modo de ir "más allá del Modelo Estándar" es estudiar las colisiones entre componentes fundamentales de la materia a energías muy altas. Este es de hecho el objetivo principal del Large Hadron Collider (LHC), el acelerador construido en el CERN en el cual se harán colisionar protones contra protones a una energía total de 14 TeV, la más alta lograda en el laboratorio hasta ahora.

El IFAE participa de manera importante en el proyecto ATLAS, uno de los dos experimentos con objetivos generales que se llevarán a cabo en el LHC. El detector ATLAS es un aparato muy complejo, construido en docenas de laboratorios en el mundo entero. El IFAE fue uno de los centros en los que se ensambló uno de los subdetectores más grandes de ATLAS, el Calorímetro Hadrónico llamado TileCal (para Tile Calorimeter). Este subdetector consiste en tres "barriles", cada uno hecho de 64 módulos. En la primavera de 2002 el IFAE completó la producción en Barcelona de un barril completo (64 módulos, cada uno con un peso de 12 toneladas, además de uno de recambio), una tarea que comenzó en 1999. El IFAE también diseñó y fabricó la electrónica de calibración de TileCal (11,000 canales de amplificación y 370 circuitos de conversión analógica-digital), cuya producción fue terminada en 2004. El calorímetro hadrónico fue el primer detector instalado en la caverna experimental de ATLAS, en 2005. Una vez allí se realizaron extensas pruebas de los sistemas de lectura electrónica y de calibración, en los que el grupo del IFAE participó y sigue participando con un papel destacado. En la figura se enseña un rayo cósmico detectado en TileCal y en otros detectores de ATLAS en 2006.

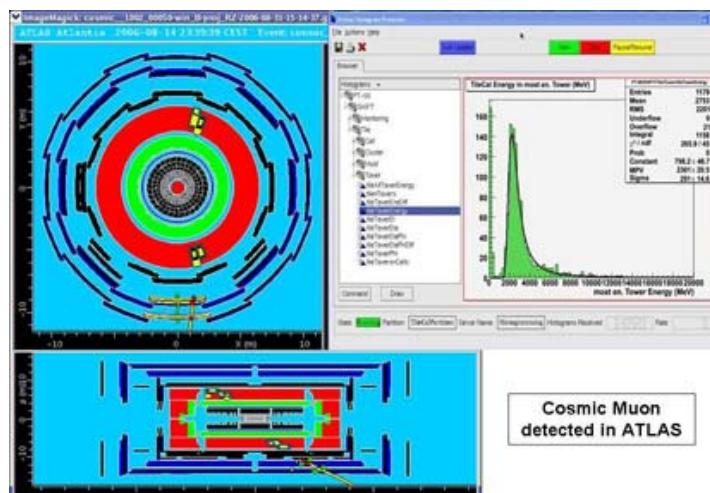

*Un rayo cósmico pasando por el detector tal cómo se visualiza en ATLAS (izquierda); energía depositada por muones cósmicos en TileCal (derecha).*

Además de este trabajo sobre el propio detector, el IFAE está muy involucrado en otros aspectos del experimento ATLAS, entre ellos

a) Participación en el análisis de los datos tomados con haces de prueba de los módulos del calorímetro.

b) Implementación de los algoritmos de Flujo de Datos ("Dataflow") y de las Tareas de Procesado (PT, siglas de "Processing Tasks") del Filtro de Sucesos ("Event Filter"). El Event Filter es un conjunto de códigos que selecciona datos para un ulterior análisis. El Dataflow es un componente estructural crucial del Event Filter, mientras que el PT sirve como interfaz y ejecuta las tareas de selección de sucesos. El IFAE es responsable de estas dos componentes. En 2006, el trabajo de selección de sucesos se enfocó en las prestaciones del sistema en seleccionar

sucesos con Taus, una señal de nuevos procesos no previstos por el SM.

c) Preparación del análisis de canales de "descubierta", estudiando la simulación de reacciones de fondo que necesitan un entendimiento en profundidad – también por su interés intrínseco. Más detalles de estos estudios se dan más abajo.

d) Preparación de la infraestructura de cálculo necesaria para el experimento, como se describe más abajo.

e) El seguimiento, administrativa y técnicamente, del contrato entre el CERN y una empresa española, para la fabricación de las 8 vasijas de vacío de 25m x 5m que albergan las bobinas del Imán Toroidal. En la figura se enseña este imán, completamente instalado en la caverna de ATLAS, junto al barril de TileCal construido en IFAE.



*Una vista de la caverna de ATLAS en marzo de 2006. El "barril" de TileCal construido en IFAE es el cilindro marrón en la izquierda, y se está colocando dentro de los recipientes de vacío del imán toroidal, fabricadas en España. Dos de los recipientes se ven en la derecha (con tiras marrones); los recipientes albergan las bobinas superconductoras del imán.*

## CDF

El experimento CDF es en muchos aspectos un precursor de ATLAS. El experimento tiene lugar en el colisionador llamado Tevatrón, situado en el Laboratorio Nacional Fermi de Estados Unidos, en Illinois. En el Tevatrón, haces de protones y antiprotones chocan con una energía total en el centro de masas de 2 TeV. CDF ha ido tomando datos desde los primeros años noventa, obteniendo varios importantes resultados, entre ellos la descubierta del quark *top* en 1995. Considerables modernizaciones del colisionador y de CDF se realizaron al inicio de la década y están funcionando a pleno rendimiento.

Los objetivos de física son parecidos a los del LHC. Es posible que la energía de los haces no sea suficiente para detectar fenómenos más allá del SM, pero el aumento de luminosidad llevará

a medidas relevantes y quizás descubiertas en un futuro próximo. Sin embargo, el Tevatrón continúa siendo el acelerador de más alta energía en el mundo.

El grupo del IFAE mantiene una fuerte presencia en el funcionamiento de CDF, habiendo creado un sistema (llamado DQM) para monitorizar la calidad de los datos en tiempo real. Hasta 2006, el grupo ha llevado a cabo varios análisis de procesos físicos, que se han concretado en varias publicaciones y 16 ponencias en talleres y conferencias. Una búsqueda de la SuperSimetría – uno de los escenarios de nueva física teóricamente más atractivos – ha ampliado significativamente los límites sobre la masa de unas partículas supersimétricas (*squarks* y *gluinos*). Investigando las fronteras del SM, se han medido las secciones eficaces inclusivas de *jets* hadrónicos sobre 7 órdenes de magnitud, hasta energías transversas de 700 GeV, cómo se ve en la figura.

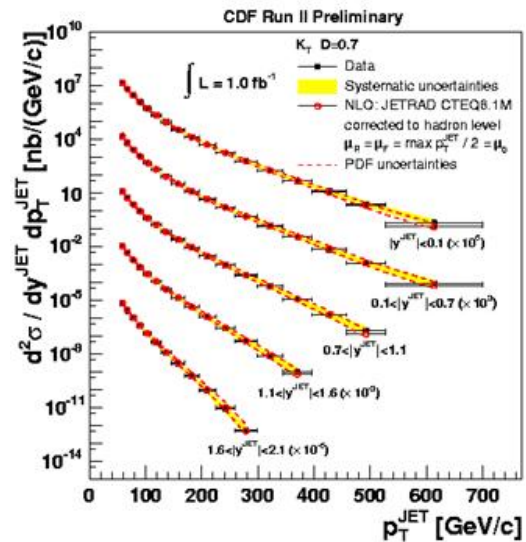

Secciones eficaces inclusivas de jets, medidas con el algoritmo  $k_T$ .

## EXPERIMENTOS con NEUTRINOS

En el experimento K2K sobre oscilaciones de neutrinos un haz de dichas partículas, producido en el laboratorio KEK de Japón, es enviado al laboratorio Kamioka, situado a 250 kilómetros de distancia. Los neutrinos viajan por la tierra con una atenuación insignificante. El experimento mide el flujo de neutrinos de tipo muónico en dos posiciones diferentes: cerca de la fuente donde son producidos, en el propio laboratorio KEK, y a 250 kilómetros de distancia en Kamioka, en la parte occidental de Japón. Para este propósito el experimento tiene dos detectores: uno a 200m del punto de producción de los neutrinos, y otro más lejano en Kamioka, el detector Super-Kamiokande. Este consiste en un enorme tanque (50,000 toneladas) de agua muy pura. El flujo es medido contando el número de interacciones cuasi-elásticas de neutrinos muónicos en un volumen dado de ambos detectores. Las medidas en el detector cercano son extrapoladas al detector lejano y comparadas con lo que es realmente medido allí.

La toma de datos finalizó en noviembre del 2004, y el análisis de los resultados sobre oscilaciones se publicaron en 2005 [E. Aliu et al., Phys. Rev. Lett. 94:081802, (2005)]. En la figura se muestra la distribución de energía de

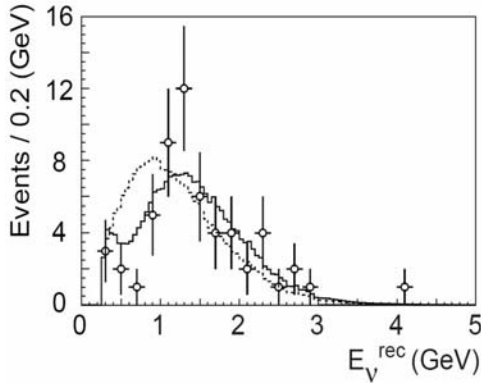

*La energía reconstruida de los sucesos con un muón en SuperKamiokande.*

los sucesos casi-elásticos (muones) en Superkamiokande, comparada con lo esperado en ausencia de oscilaciones (línea de puntos) y con oscilaciones (línea sólida). El mejor ajuste a los datos conduce a los parámetros  $(\sin^2 2\theta, \Delta m^2) = (1.0, 2.8 \times 10^{-3} \text{ eV}^2)$ . Con estos parámetros el número esperado de sucesos casi-elásticos es de 103.8, en acuerdo con los 107 observados y no con el número esperado en ausencia de oscilaciones:  $151 \pm 11$ . Este resultado confirma, en un experimento controlado, la interpretación de los resultados de 1998 de Super-Kamiokande.

El IFAE también participa en T2K, un experimento de neutrinos de segunda generación. En T2K un haz de neutrinos mucho más intenso, producido en el nuevo acelerador JPARC que se está construyendo en Tokai, será enviado a Super-Kamiokande, a 300 km de distancia. El trabajo del IFAE se ha enfocado en el detector cercano, un espectrómetro a 280 m del blanco de producción de neutrinos. Se utilizará un grande imán de bajo campo (0.2 T, ver siguiente figura) Las partículas cargadas se

detectarán con una “Time Projection Chamber” (TPC).

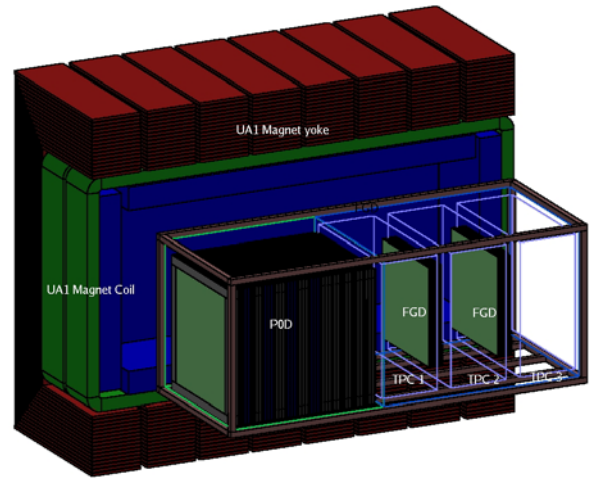

*Vista en sección del espectrómetro de T2K, a 280 m del punto de producción de los neutrinos. El haz entra en el detector por la izquierda.*

El objetivo principal de T2K es observar las transformaciones de neutrinos muónicos a neutrinos electrónicos, la cual dará información sobre un parámetro aún desconocido de las oscilaciones.

El IFAE ha dado muchas aportaciones al diseño del detector y a las pruebas que han llevado a escoger el detector que leerá la TPC, llamado MicroMegas. Los prototipos del detector se han probado con rayos cósmicos en la TPC del experimento HARP en el CERN, en 2005 y 2006 (ver figura).

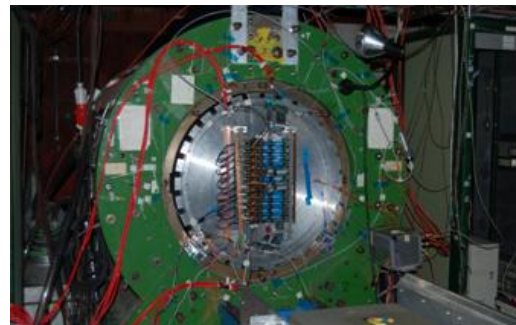

*Montaje en el CERN: el prototipo de lectura dentro del imán (verde) y de la caja electrostática de HARP (aluminio).*

El primer prototipo de toda la TPC de T2K estará completo y en marcha a finales de 2007, para tener todo el detector instalado en Tokai en 2009.

El grupo IFAE está también involucrado en un proyecto que se podría llevar a cabo en la nueva sala experimental del Laboratorio Subterráneo de Canfranc (LSC). La profundidad del laboratorio – que minimiza los fondos de rayos cósmicos - y el área disponible brindan oportunidades excitantes de lanzar en LSC un nueva generación de experimentos sobre la desintegración nuclear con dos electrones y sin neutrinos. Estos procesos son sumamente infrecuentes, sin embargo si se revelaran de forma cierta otorgarían resultados de gran

trascendencia sobre la naturaleza de los neutrinos.

## MAGIC

MAGIC es el acrónimo de Major Atmospheric Gamma-Ray Imaging Telescope. El telescopio está situado en el Observatorio del Roque de los Muchachos (ORM) en la Isla de La Palma de las Canarias (28.8N, 17.9W, altitud 2200m). El objetivo del experimento es el estudio de los rayos gamma de muy alta energía que llegan a la Tierra de un número relativamente pequeño de fuentes. Estos nos dan información sobre los mecanismos que producen tal radiación, que figuran entre los más violentos conocidos en el cosmos. Por otra parte la propagación de la

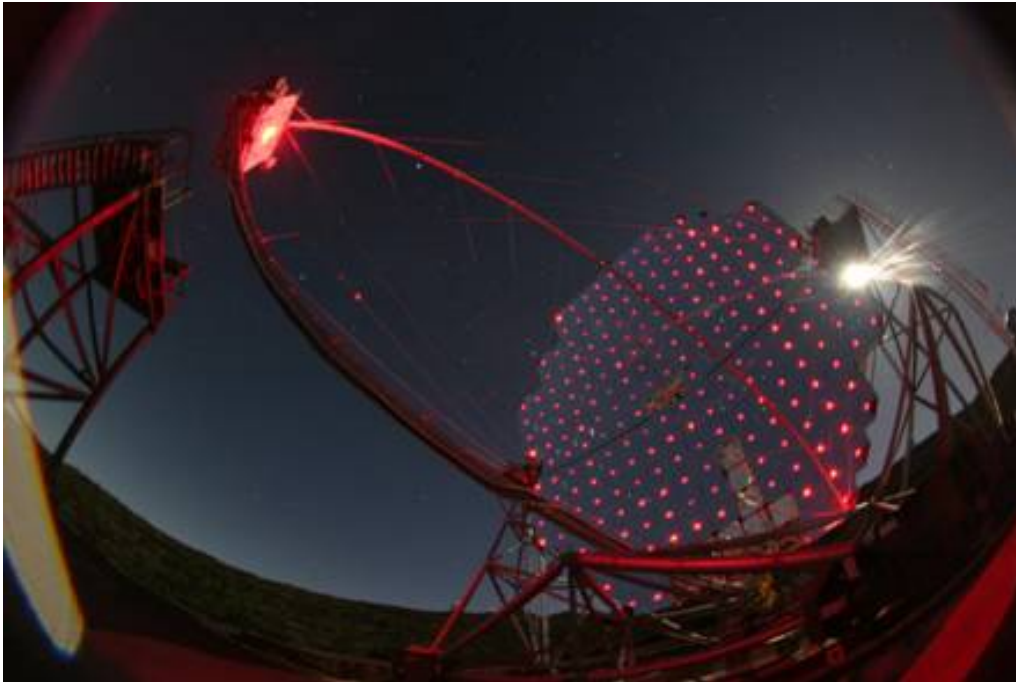

*Foto del telescopio durante el funcionamiento del sistema para el enfoque de los espejos, basado en haces de laser de referencia.*

radiación en distancias cosmológicas es sensible a la geometría y al contenido en materia del cosmos en sí mismo. MAGIC observa la luz inducida por las interacciones de los rayos gama entrantes con la parte superior de la atmósfera.

Esta luz es reflejada en un espejo segmentado de 17m de diámetro y es recogida por la cámara, localizada en el foco. La cámara contiene fotodetectores muy rápidos y sensibles.

El grupo del IFAE construyó en su totalidad la cámara del telescopio y su sistema de control, así como el edificio que aloja la electrónica y los equipos de toma de datos. Además es responsable del control general del telescopio.

El telescopio fue inaugurado en octubre de 2003 y fue puesto a punto a lo largo de 2004. A finales de 2006, los dos primeros años de observaciones habían producido 14 artículos (publicados o aceptados por las revistas) muchos de los cuales habían sido iniciados por los físicos del IFAE, o habían recibido contribuciones importantes por su parte. Cuatro tesis de doctorado se completaron durante este periodo.

Resumiendo lo más destacado de las observaciones de 2005 y 2006:

- la detección de emisión variable por una estrella binaria de rayos X fue un resultado novedoso, que se tradujo en un artículo en la revista Science.
- Se observó el espectro de rayos gama por el centro galáctico, lo que permitió poner límites muy restrictivos sobre los parámetros de la materia oscura en nuestra galaxia.
- durante la campaña de 2006 se observaron varios Núcleos Galácticos Activos (AGN). Se descubrió un nuevo AGN (Mrk 180) y se observó variación muy rápida, en la escala de minutos, durante un destello de Mrk 501. Este fenómeno permitió buscar una correlación entre la energía de los rayos gama y sus tiempos de llegada, cosa que se espera si hay ruptura de la invariancia de Lorentz debido a fenómenos de Gravedad Cuántica. Los resultados de MAGIC ponen límites estrictos a estas teorías.



*Los dos telescopios MAGIC en noviembre de 2006. El más cercano es MAGIC-II, durante la instalación de las componentes principales en el momento de tomar la foto.*

En 2004 la colaboración comenzó un programa para construir un segundo telescopio, parecido a

MAGIC, que funcionará junto con el primero, realizando así los siguientes objetivos:



(i) mejorar las resoluciones espectral y angular, así como la supresión del ruido, incrementando la sensibilidad en un factor 2, (ii) como consecuencia, un incremento del tiempo efectivo de observación en un factor 4, (iii) reducción del umbral de observación en energía sin interrupción en las observaciones, y (iv) servir como banco de pruebas para desarrollos futuros.

MAGIC-II utiliza nuevos fotosensores y una electrónica de digitalización más rápida (con muestras a 2-4 GHz). A finales de 2006, la mayor parte de la instrumentación pesada de MAGIC-II estaba ya instalada (ver figura anterior) y se planeaba que componentes importantes se entregaran en 2007, para la puesta en marcha en 2008.

### EL PROYECTO DES (Dark Energy Survey)

En el 2005 un equipo del IFAE, junto con equipos del IEEC (Institut de Estudis Espacials de Catalunya) y del CIEMAT (Centro de Estudios Energéticos Medioambientales y Tecnológicos) de Madrid, comenzó un nuevo programa de Cosmología Observacional, entrando en una colaboración hasta entonces principalmente anglo-americana, DES (Dark Energy Survey). El propósito de la colaboración es catalogar y medir el espectro de un enorme número de galaxias (unos 300 millones) y cúmulos de galaxias en una zona de 5000 grados cuadrados del hemisferio sur, en cuatro bandas ópticas. El programa tiene un objetivo ambicioso, acotar la ecuación de estado del universo, midiendo simultáneamente varios parámetros cosmológicos.

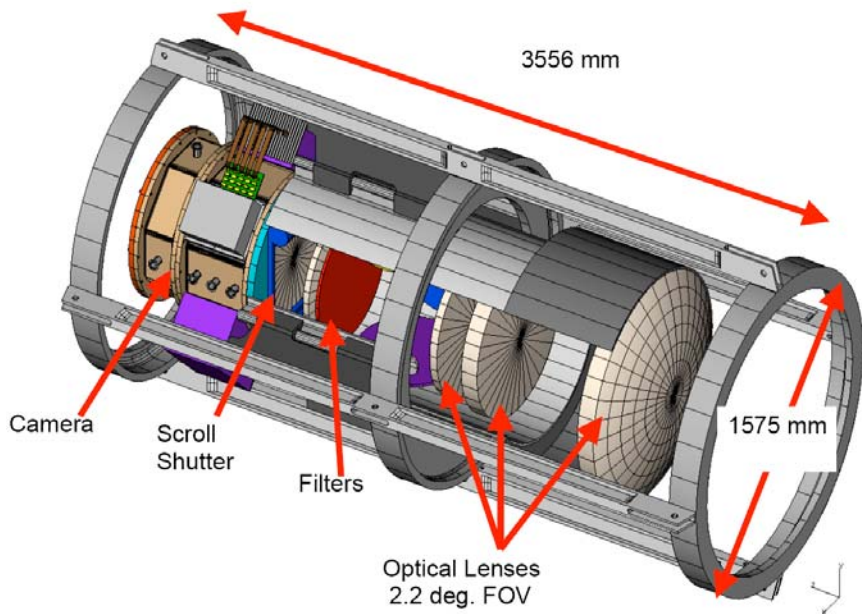

*Diseño de DECAM, la cámara de DES que se está construyendo.*

También se observará repetidamente una zona del cielo (de 40 grados<sup>2</sup>) con el objetivo de descubrir y medir el espectro fotométrico de

unas 1900 supernovas de tipo Ia, en un rango de  $z$  (corrimiento hacia el rojo),  $0.3 < z < 0.75$ .

La colaboración DES está construyendo una cámara CCD de gran ángulo (3 grados<sup>2</sup>), que irá situada en el foco principal del telescopio Blanco, de 4m de diámetro, situado en el Cerro Tololo de Chile. A cambio la colaboración obtiene un 30% de todo el tiempo de observación. Dicho telescopio forma parte de la organización NOAO (National Optical Astronomy Observatory) de EE. UU., financiada por la NSF. NOAO hizo una convocatoria de proyectos para equipar al telescopio Blanco con un nuevo instrumento, siendo DES el proyecto elegido. Los tres grupos españoles serán financiados por el Programa Nacional de Astronomía y Astrofísica.

La figura anterior muestra el diseño de la cámara de DES (denominada DECam), que tendrá 519 megapixels de CCDs de un nuevo diseño, más eficientes en la zona roja e infrarroja-cercana del espectro que los anteriores. Por su tamaño, esta cámara representará un nuevo hito en astronomía óptica.

Los grupos españoles están involucrados en el diseño y la fabricación de la electrónica de lectura de los píxeles y de sus controles. El grupo IFAE tiene un papel central en esta actividad, por haber construido y puesto en marcha, en 2006, un banco de prueba de la electrónica, con criogenia, que permitirá además hacer estudios fotométricos de la respuesta de los píxeles. Estas actividades se describen en detalle más adelante.

Por los aspectos científicos, el grupo IFAE está muy involucrado en el programa sobre las Supernovas Ia como sondas de la Energía Oscura, y en la preparación del análisis de los datos. Además el grupo participa en otras propuestas de proyectos futuros.

## **PROYECTO de DETECTOR de RAYOS X**

El Instituto persigue muy activamente una línea de investigación aplicada en detectores con finalidades médicas, en concreto, el desarrollo de una cámara digital de rayos X para obtener una imagen de alta calidad con una dosis muy baja de radiación. El detector está pensado para mamografía y está basado en detectar los rayos

X con un semiconductor denso. La alta eficiencia de conversión de rayos X del material es lo que permite producir imágenes de alta calidad con dosis de radiación muy reducidas en comparación con la radiografía convencional.

En física de altas energías, detectores en semiconductores se han ido utilizando por muchos años. La presencia en IFAE de personal técnico y científico con conocimiento de estas técnicas nos ha permitido afrontar un proyecto de estas características.

IFAE presentó a la Unión Europea un proyecto de investigación en esta línea, como coordinador de 6 institutos europeos. Los demás institutos españoles incluyen El Centro Nacional de Microelectrónica (CNM), que también está en el campus de la UAB, y el Hospital Parc Taulí de Sabadell. El proyecto, con las siglas de DearMama, fue aprobado a finales del 2000. El objetivo principal era producir un prototipo completo de detector para el uso en mamografías.

El objetivo se logró. Un sistema de radiografías se puso en marcha en 2005 y fue sometido a pruebas clínicas en 2006. El equipo del Dr. M. Sentís condujo las pruebas.



*Una enfermera montando una muestra de “lumpectomía” en Dear-Mama-I en el Hospital Parc Taulí.*

En la figura anterior se ve la máquina Dear-Mama-I en la cual se ha montado una muestra histológica. Los resultados se dan más abajo en esta memoria.

El proyecto de l Unión Europea se alargó hasta septiembre de 2006 para efectuar pruebas más completas. Este término encajó con el plan de una segunda máquina de rayos X, basada en un ulterior desarrollo de la tecnología del detector, que también se construyó en 2006. Conocida como Dear-Mama-II, esta máquina es dedicada a las radiografías óseas, y utiliza un detector de píxeles de Cd Te leído por electrónica que cuenta los fotones.

La mayor densidad del detector de CdTe permite el uso de dosis de radiación aún más bajas con las mismas o mejores prestaciones en términos de resolución y contraste de la imagen. Más resultados y comparaciones se dan en el capítulo 6 de la memoria.



*La máquina Dear-Mama-II de radiografía ósea, completa, instalada y lista para el uso en UDIAT (Hospital de Parc Taulí).*

Este trabajo ha generado una patente en USA y continúa en una empresa de *spin-off*, X-ray Imatek SL, creada en 2006 con el estímulo y el apoyo de la Generalidad.

## 2.2 La División de Teoría en 2006

La actividad de la División de Teoría puede ser clasificada en tres líneas principales de investigación: información cuántica, astrofísica de partículas y física de las interacciones fundamentales.

### Información Cuántica

La Información Cuántica es un área de investigación multidisciplinar en la cual la física cuántica se junta con campos tan diferentes como la estadística matemática, la criptografía, la informática y la nanotecnología, entre otros. La información cuántica utiliza las leyes de la mecánica cuántica, es decir, las leyes del mundo microscópico, para efectuar eficientemente ciertas tareas de computación que no admiten tratamiento dentro de la física clásica y de los ordenadores actuales.

El Grupo de Información Cuántica (GIQ) aúna investigadores adscritos a la UAB y cuyo trabajo se enfoca principalmente en el campo de la información cuántica y el “entanglement”. El GIQ no es una entidad oficialmente reconocida, sin embargo incluye todos los participantes en los proyectos QUIRT I y II (Quantum Information and Related Topics) financiados por el MEC y por la Red Temática Europea QUPRODIS IST2002.

### Astrofísica de Partículas

Es generalmente reconocido que este campo, conocido también como astropartículas o cosmología de partículas, se encuentra en una fase de rápida expansión. Las oscilaciones de neutrinos, detectadas en experimentos de neutrinos atmosféricos y solares, constituyen una descubierta de gran trascendencia para la física de los neutrinos, un campo en el cual el grupo del IFAE ha ido trabajando muchos años. Nuestro trabajo se caracteriza por el estudio de aspectos teóricos de la física de las partículas

elementales y sus interacciones, especialmente en un ambiente astrofísico o cosmológico. En estos medios se verifican procesos físicos que están suprimidos en el laboratorio, o bien se concretan de otras maneras.

### **Física de las interacciones fundamentales**

A pesar de sus éxitos, hay muchas indicaciones que el SM no puede ser completo. Hay pruebas experimentales que los neutrinos tienen masa (aunque no se sepa de cual tipo). Además sabemos que la asimetría entre partículas y antipartículas en el universo no se puede explicar en el SM, porque en ello no hay bastante violación de CP. Y finalmente, la gravedad aun se resiste a todos los intentos de cuantización, al contrario de las demás interacciones fundamentales.

Es muy probable que los experimentos en el LHC revelen las respuestas a unas de estas preguntas. Nuestro grupo se dedica al estudio de la física en la escala electrodébil, de la origen de las masas y de importantes simetrías discretas como CP. En eso, tanto conceptos como SuperSimetría, Dimensiones Extra o la reciente “Unparticle Physics”, como la Física de Precisión del Sabor o las Interacciones Fuertes No-Perturbativas juegan un papel importante. Y finalmente, pensamos que es importante conocer las implicaciones para la física de partículas de modelos de cosmología y astrofísica.

### **3. SUMMARY**

Versió en Català a pàgina 1.

Versión en Castellano en página 13

This report covers the activities of the High Energy Physics Institute of Barcelona (Institut de Física d'Altes Energies, IFAE) during 2006.

#### **IFAE Structure**

The IFAE is a consortium between the Generalitat de Catalunya (the Government of the Autonomous Region of Catalonia) and the Universitat Autònoma de Barcelona (UAB). It was formally created on July 16 1991, by Act number 159/1991 of the Generalitat. As a Consortium the IFAE is a legal entity with its own independent legal status. Functionally it depends from the Department of Universities, Research and Society of Information (DURSI) of the Generalitat.

The IFAE complements its own staff with that of the Theoretical and Experimental High Energy Physics Groups of the Department of Physics of the UAB; it is comprised of the Experimental and Theoretical Divisions. The personnel of the two divisions is listed in page 39 of this report.

The governing bodies of the Institute are the Governing Board (Consell de Govern) and the Director. The general lines of activity, the hiring of personnel, the annual budget and the creation and suppression of Divisions are among the responsibilities of the Governing Board, which also appoints the Director from a list of candidates nominated by the Rector of UAB. The Director is responsible for the execution of the decisions of the Governing Board. The Coordinators of the Divisions are nominated by the Director and appointed by the Governing Board. The members of the Governing Board during 2006 are listed in page 38.

IFAE also has the status of a "University Institute" attached to UAB. This formula allows the personnel of the IFAE to participate in the educational programme of UAB, in particular in doctoral courses.

In 2004 IFAE joined its parents institutions, the UAB and the DURSI, as well as CIEMAT (Center for Research in Energy and Environment Sciences, a National research organization based in Madrid) to create and promote the Scientific Information Port (PIC). This center, located on the UAB campus, very close to IFAE, aims at supporting projects that require distributed access to large amounts of data, such as the future experiments at the LHC facility of CERN. The IFAE was charged by the other partner institutions with administrating it. The PIC has its own Director and Governing Board. The activities of PIC are described in its own reports.

#### **IFAE Goals**

As stated in the foundational Act 159/1991 of the Generalitat, the mission of IFAE is to carry out research and to contribute to the development of both theoretical and experimental High Energy Physics.

The origins of the consortium are in the Department of Theoretical Physics and in the Laboratory for High Energy Physics (LFAE) of UAB. The theoretical group was established in 1971, when the university was founded. The Laboratory for High Energy Physics was created in 1984, in order to start research in experimental high-energy physics at UAB, particularly to use effectively the CERN laboratory, after Spain rejoined the CERN organization in 1982. As mentioned in Act 159/1991 the existence of LFAE and of theoretical research groups in Catalonia, the desire to strengthen research in High Energy Physics, particularly in the experimental side, and the desire to collaborate with the Spanish

Government's effort to develop this field, led the authorities of the Generalitat to create the IFAE in 1991.

In the ensuing years the experimental division of IFAE grew from a staff of 15 to about 65 at present. The experimental program has also expanded both in the number of projects and on their scope. In 1992 the group was involved on one experiment in high energy particle physics, ALEPH at LEP, while at present there are four different lines of research: particle physics at colliders with ATLAS and CDF, neutrino physics, with K2K and T2K, particle astrophysics, with MAGIC, and applied physics, with the X-Ray project. In 2006 a line in observational cosmology, established in 2005 with the DES (Dark Energy Survey) project, was strengthened. In addition there is a very close collaboration with PIC on the computational side of the experiments.

The Theoretical Division also expanded its research program since the IFAE was created. There are at present three main lines of research: physics of the fundamental interactions, astroparticle physics and quantum information. The fact that the IFAE is an independent legal entity allows it to manage its own projects as well as certain external ones.

From 1995 to 2001 the Synchrotron Light Laboratory of Barcelona (LLS) was administratively part of IFAE. The LLS was the organization that proposed the construction of a Synchrotron Light Source in Barcelona. The project was jointly approved in 2003 by the Spanish Government in Madrid and the Catalan Government; the Synchrotron is now under construction.

The IFAE was also the institution responsible for the construction of the MAGIC building at the Roque de los Muchachos site in the Island of La Palma; it now manages the Common Fund

(maintenance and operation funds) of the MAGIC experiment.

Since 1999 the IFAE also provided technical and administrative management of the contract between CERN and a Spanish company for the construction of the vacuum vessels of the ATLAS Barrel Toroid - as described further below.

Brief descriptions of the research projects of IFAE's Experimental and Theoretical Divisions are given in this section. More details are given in chapter 7 of this report.

## **1.1 The Experimental Division in 2006**

During 2006 the Experimental Division continued its involvement in six major projects:

- ATLAS, an experiment in preparation for the future LHC accelerator being built at the European Center for Particle Physics (CERN),
- CDF, a proton-antiproton collider experiment taking place at the Fermi National Accelerator Lab in the USA,
- K2K and T2K, two neutrino long base-line experiments taking place in Japan,
- MAGIC, an experiment in particle astrophysics taking data at the Canary Islands,
- DES (Dark Energy Survey), building a telescope to observe about 300 million galaxies visible from the Southern Hemisphere, for cosmology studies.
- DearMama, a EU-funded project that developed a digital X-ray camera of high resolution and contrast with very small exposure to radiation.

In addition, the IFAE neutrino group is studying a possible experiment that would take place in the Canfranc underground laboratory, near Jaca.

## ATLAS

During the last decades of the 20th century Particle Physics reached a global synthesis, embodied in what is known as the Standard Model, or SM. The SM describes with extraordinary precision three of the fundamental interactions among elementary constituents of matter in terms of quantum field theories: the strong, weak and electromagnetic interactions. No single result, with the exception of non-zero neutrino masses, originally assumed to be zero in the model, is in serious contradiction with the theory. In particular, the generation of experiments done at electron positron colliders, such as CERN's LEP, have put the model to stringent tests.

But despite its enormous success, the Standard Model is not a complete theory for it leaves unanswered a number of fundamental questions. The consensus, built up during the past few years, is that the best way to go "beyond the Standard Model" is to study collisions between fundamental constituents of matter at very high energies. This is in fact the main goal of the Large Hadron Collider (LHC), the accelerator built at CERN, in which protons will be made to

collide against protons with a total energy of 14 TeV, the highest ever achieved in a laboratory.

IFAE is a major player in ATLAS, one of the two general purpose experiments that will take place at the LHC. The ATLAS detector is a very complex apparatus, built in dozens of laboratories around the world. The IFAE was a focal point in the assembly of one of the largest of the ATLAS sub-detectors, the Hadron Calorimeter, or TileCal (short for Tile Calorimeter). This sub-detector consists of three "barrels", each made of 64 modules. In the spring of 2002 the IFAE completed the production in Barcelona of one complete barrel (64 modules, each weighting 12 tons, plus 1 spare), a task that started in 1999. The IFAE also designed and fabricated the TileCal calibration electronics (11,000 amplifier channels and 370 digital conversion circuits). The production of the latter was finished in 2004. The hadronic calorimeter was the first detector installed in the cavern of the ATLAS experiment, in 2005. Once in place, extensive tests of the electronic readout systems and of the calibration were carried out, in which the IFAE had and still has a major role. The figure shows a cosmic ray detected in TileCal and in other ATLAS detectors in 2006.

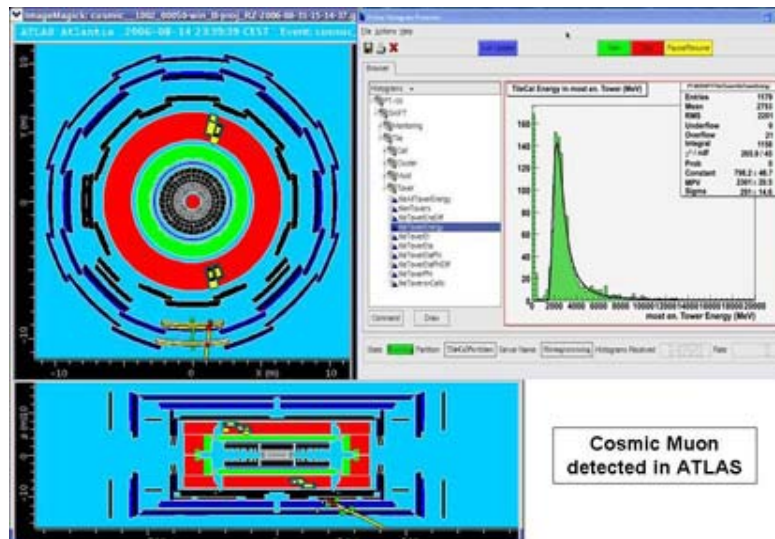

*The ATLAS Event Display showing a cosmic ray going through the detector (left); Energy deposited by cosmic muons in TileCal (right).*

In addition to the work on the detector itself, IFAE is heavily involved in other aspects of the ATLAS experiment, among them:

a) Participation in the analysis of the test-beam data of the calorimeter modules.  
b) The implementation of the Dataflow and Processing Tasks (PT) algorithms of the Event Filter of ATLAS. The Event Filter is a complex software package that selects data for further analysis. The Dataflow algorithm is a critical infrastructural component of the Event Filter, while the PT serves as an interface and executes the event selection tasks. IFAE is responsible for these two components. In 2006, the focus of the event selection work was on the performance of the system in selecting events with Tau triggers, a likely signal of new, beyond-SM processes.

c) Preparations of the analysis of “discovery physics” channels, by studying simulated background reactions that need careful understanding, also in view of their intrinsic interest. Further details of these studies are in the main body of this report.

d) Preparations of the computing infrastructure needed for the experiment, described below.

e) management of the contract between CERN and a Spanish company for the manufacturing of the eight 25m x 5m vacuum vessels containing the coils of the ATLAS Barrel Toroid Magnet. This magnet, fully installed in the ATLAS cavern together with the TileCal barrel built at IFAE, is shown in the next figure.



*A view of the ATLAS cavern in March 2006. The Tilecal Barrel built at IFAE (brown cylinder on the left) is being inserted into the huge toroidal magnet vacuum vessels, built in Spain. Two of the eight vessels (with brown stripes) are visible on the right hand side of the figure; they enclose the superconducting coils of the barrel toroidal magnet system.*



## CDF

The CDF experiment is in many ways a forerunner of ATLAS. It takes place at the Tevatron Collider of the Fermi National Accelerator Laboratory of the U.S.A., in Illinois. In the Tevatron, two one-TeV proton and antiproton beams collide head-on, giving a total centre of mass energy of 2 TeV. CDF has been running since the early nineties and has produced many important results, among them the discovery of the top quark in 1995. An important upgrade of the collider and of CDF has been in full swing since the beginning of the decade.

The physics goals are similar to those of the LHC, although the lower energy of the beams may not allow to reach the scale at which new phenomena, beyond the SM, are manifest.

Nevertheless, the higher luminosities will provide important measurements in the near future and may lead to discoveries, while the Tevatron remains the highest-energy accelerator laboratory in the world.

The IFAE group strongly contributes to the operation of CDF, having created a system for monitoring the quality of the data (known as the DQM) in an online, real-time environment. As of 2006, the IFAE group has carried out several physics analyses, leading to several publications and 16 communications to workshops and conferences. A search for SuperSymmetry – one of the preferred theoretical scenarios for new phenomena – significantly expanded the limits on the mass for (SuperSymmetric) squarks and gluinos. On the line of probing the limits of the SM, inclusive jet cross sections have been measured over 7 orders of magnitude, up to transverse energies of 700 GeV, as shown in the figure.

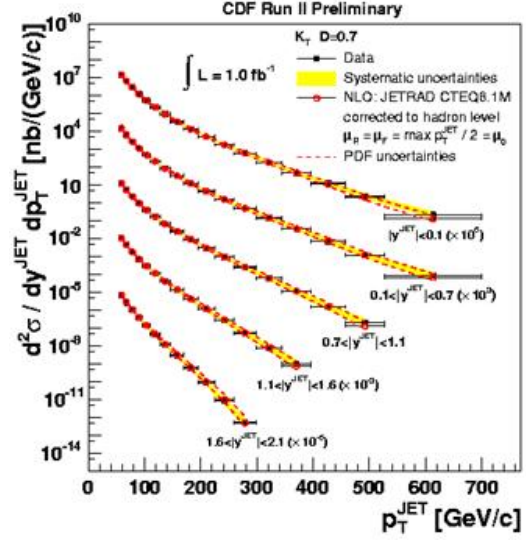

*Measured inclusive jet cross section using the  $k_T$  algorithm.*

In close collaboration with the PIC, the IFAE-CDF group installed a computer farm which has been instrumental to the IFAE analysis projects and is used for massive simulations by the entire collaboration. As of the end of 2006 the farm had reached almost 100% occupancy.

## NEUTRINO EXPERIMENTS

The K2K neutrino oscillation experiment is a long-baseline experiment in which a beam of neutrinos, produced in the KEK laboratory in Japan, is sent to the Kamioka mine, located 250 Km away. The neutrinos travel through the earth with negligible attenuation. The experiment measures the flux of muon-type neutrinos at two different locations: near the KEK laboratory, where they are produced, and 250 Km away at the Kamioka mine in western Japan.

For this purpose, the experiment has two detectors: a near detector placed 200m downstream of the neutrino production target, and a far detector in Kamioka, the Super-Kamiokande detector, consisting of a huge tank (50,000 tons) of very pure water. The flux is measured by counting the number of quasi-

elastic muon-neutrino interactions in a given fiducial volume of the two detectors. The measurements at the near detector are extrapolated to the far detector and compared with what is actually measured there.

Data taking was completed in 2004, and the analysis of the results on oscillations was published in 2005 [E. Aliu et al., Phys. Rev. Letters 94:081802 (2005)]. The figure below shows the energy distribution of quasi-elastic (muon) events in SuperKamiokande, compared with that expected in the absence of oscillations (dotted line) and with oscillations (solid line).

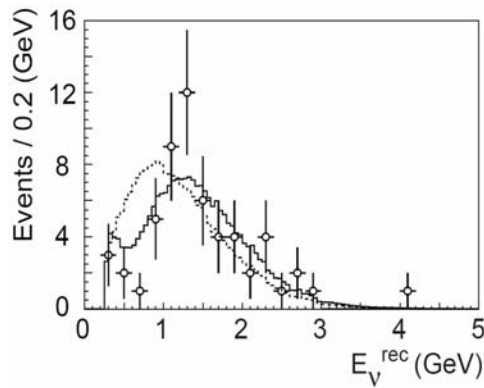

*The reconstructed energy of one-ring events (compatible with one muon) in SuperKamiokande.*

The best fit to the data gives the parameters  $(\sin^2 2\theta, \Delta m^2) = (1.0, 2.8 \times 10^{-3} \text{ eV}^2)$ . With these parameters the expected number of quasi-elastic events is 103.8, comparable to the 107 observed and very different from the expected number in absence of oscillations:  $151 \pm 11$ . This result confirms, in a controlled experiment, the interpretation of the 1998 atmospheric neutrino results of SuperKamiokande.

The IFAE group is also involved in a second-generation long-baseline neutrino experiment, T2K. Here, a much more intense beam of neutrinos, from the new accelerator JPARC being built in Tokai, Japan, will be sent to Super-Kamiokande, 300 km away. The IFAE group's efforts focus on the near detector, that will be a spectrometer at 280 m from the neutrino production target. It will use a large,

low-field magnet (0.2 Tesla), shown in the next figure. The charged particles will be detected by a Time Projection Chamber (TPC).

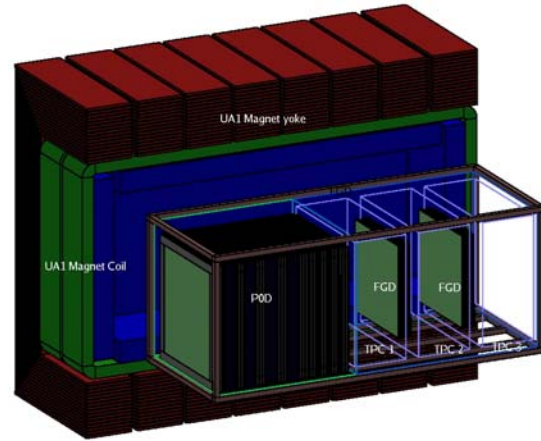

*Cross-sectional view of the spectrometer at 280m from the neutrino production point of T2K. The beam enters the detector from the left.*

The main goal of this experiment is to measure the muon-neutrino to electron-neutrino transition rate, which will give information on a still unknown parameter of the oscillations. This experiment has been approved by the Japanese authorities and has a large participation from European groups.

IFAE contributed extensively to the detector design studies, and to the tests leading to the choice of the TPC readout detector, known as MicroMegas. The prototypes of this detector have been tested with cosmic rays in the TPC of the HARP experiment, at CERN, in 2005 and 2006 (see next figure).



*The readout prototype inside the magnet (green) and the HARP field cage (aluminum).*

The first prototype of the full T2K TPC will be built and operated by the end of 2007, in view of having the entire detector installed at Tokai in 2009.

The IFAE group is also involved in a possible experiment to be carried out in the new experimental hall of the Canfranc underground laboratory (LSC). The depth of the laboratory – which minimizes the backgrounds from cosmic rays - and the available surface area present exciting opportunities to perform at the LSC a next-generation experiment on neutrino-less double-beta decay. These exceedingly rare nuclear process, if conclusively detected, would give a very fundamental result on the nature of neutrinos.

## MAGIC

MAGIC is the acronym of Major Atmospheric Gamma-ray Imaging Telescope. The telescope is located at the Roque de los Muchachos Observatory (ORM) in the Island of La Palma

of the Canary Islands (28.8N, 17.9W, 2200m altitude), shown in the picture below. The objective of the experiments is the study of the very high energy gamma radiation arriving to Earth from a relatively small number of sources. This study gives information on the mechanisms that produce such radiation, the most violent known in the cosmos. Furthermore the propagation of the radiation over cosmological distances is sensitive to the geometry and matter contents of the cosmos itself. MAGIC detects the light induced by the interactions of the incoming gamma rays with the upper atmosphere. This light is reflected onto a segmented mirror of 17m diameter and collected in the camera, located at the focal point. The camera is provided with very fast and sensitive photo-detectors.

The IFAE group built the camera of the telescope and its control system, as well as the building housing the electronics and data taking equipment. In addition IFAE is in charge of the overall control of the telescope.

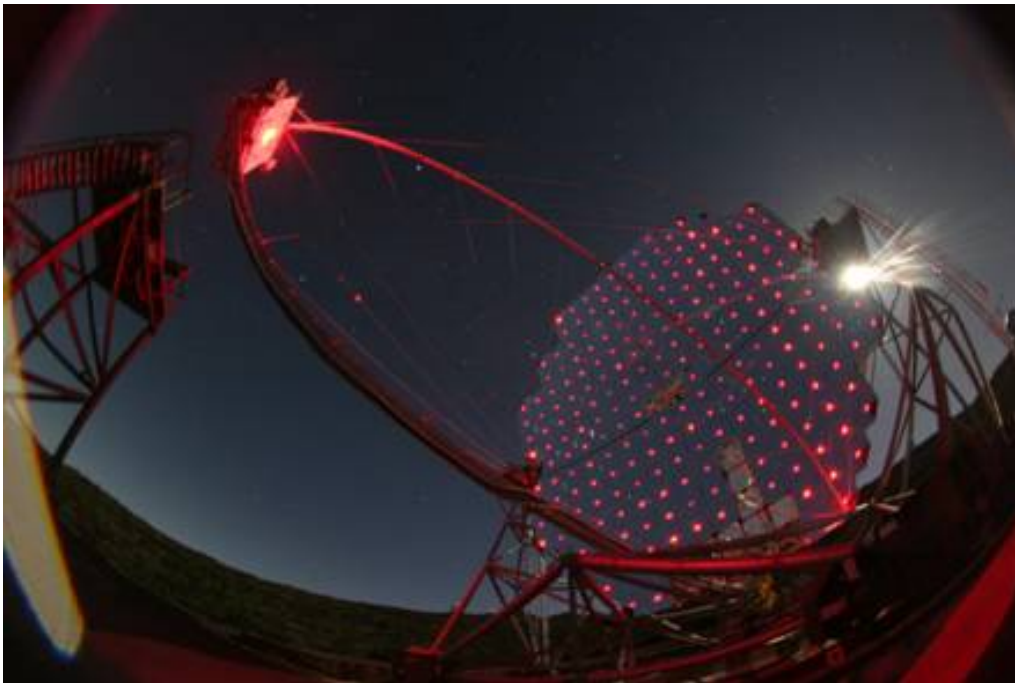

*A picture of the telescope during operation of its mirror focusing system, based on reference laser beams.*

The telescope was inaugurated in October 2003 and was commissioned during 2004. By the end of 2006, the first two years of observations produced fourteen papers (published or accepted by journals), many of which were initiated or had strong contributions from the IFAE physicists. Four PhD theses were completed during this period.

Summarizing the highlights of the 2005 and 2006 observations:

- detection of variable emission from an X-ray binary system was a novel result, resulting in a Science magazine paper.

- the observed gamma-ray spectrum from the galactic center allowed to set stringent upper limits on the dark matter parameters in our galaxy.

- several Active Galactic Nuclei (AGNs) were observed during the 2006 campaign, which produced the discovery of a new AGN (Mrk 180) and the observation of extremely fast variability, on the scale of a few minutes, during a Mrk 501 flare. This phenomenon allowed searching for energy-dependent delays in gamma-ray arrival times. Such delays are expected if Lorentz invariance is broken, as a result of Quantum Gravity phenomena. The MAGIC results set stringent limits on such theories.



*The two MAGIC telescopes in Nov. 2006. The nearer instrument is MAGIC-II, undergoing installation of its main components at the time of the picture.*

In 2004 the collaboration started a program to build a second telescope, similar to MAGIC, which will operate jointly with the first, thus

fulfilling the following goals: (i) improving the spectral and angular resolutions, and noise rejection, giving a factor of 2 improvement in

sensitivity. (ii) the consequent increase of the effective observation time by a factor of 4, (iii) lower energy threshold, without interrupting the observations for R&D, and (iv) serve as a test bench for future developments.

MAGIC-II uses new photosensors and faster (2-4 GHz sampling) digitization electronics. As of late 2006, the heavy MAGIC-II hardware was mostly installed (see figure) and major components were scheduled to be delivered in 2007, in line with beginning operations in 2008.

**THE DES (Dark Energy Survey) PROJECT**

In 2005 IFAE and groups from the Institut d'Estudis Espacials de Catalunya (IEEC) and Centro de Investigaciones Energéticas, Medioambientales y Tecnológicas (CIEMAT), started a new program in Observational Cosmology, by joining the (prevalently) anglo-

american DES (Dark Energy Survey) collaboration.. The aim of DES is to catalogue and measure the spectrum of an enormous number of galaxies (about 300 million) and clusters of galaxies in a 5000 square degrees region of the Southern Hemisphere, in four wavelength bands. This program has an ambitious goal, constraining the equation of state of the universe, by simultaneously measuring several cosmological parameters. A smaller region of the sky (of 40 deg<sup>2</sup>) will be observed repetitively, with the goal of discovering about 1900 type Ia Supernovae, in the redshift (z) range of 0.3<z<0.75, and measuring their photometric spectrum.

The DES Collaboration is building a very large aperture CCD camera (3 deg<sup>2</sup>), to be deployed at the primary focus of the 4m diameter Blanco Telescope, located in Cerro Tololo in Chile. In return the collaboration will be granted 30% of the observation time

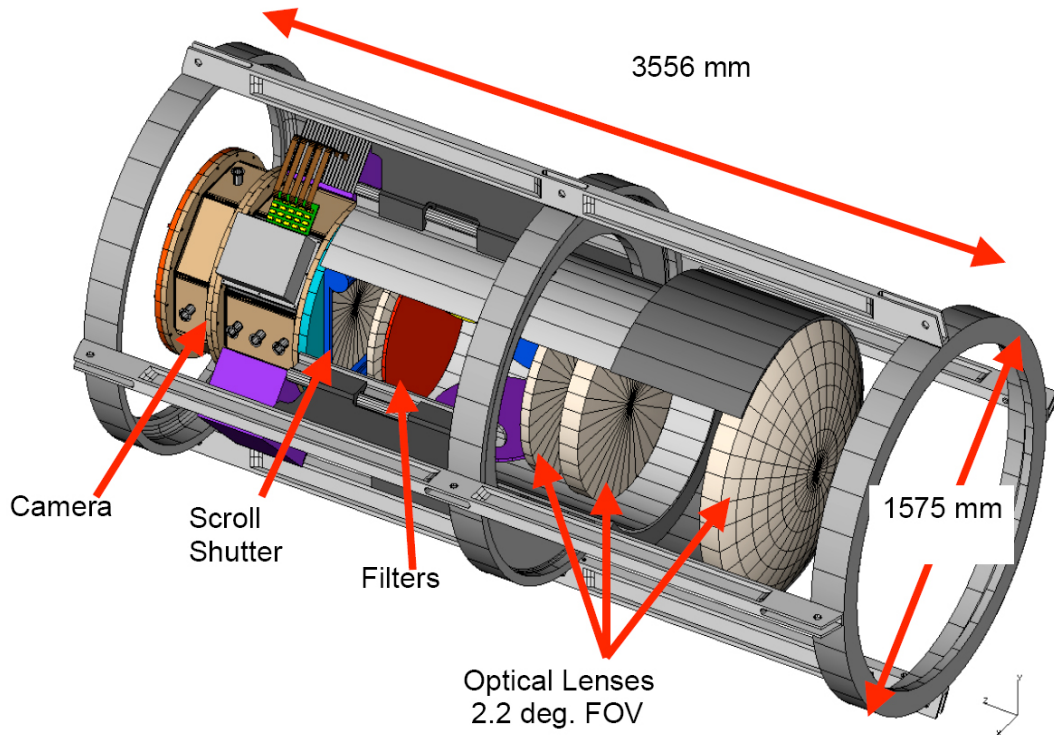

*The layout of DECam, the DES camera currently under construction.*

This telescope belongs to the USA NOAO (National Optical Astronomy Observatory) funded by the NSF. A NOAO call for proposals to equip the Blanco telescope with a new instrument, resulted in the selection of the DES camera. The three Spanish groups will be funded by the Spanish Program of Astronomy and Astrophysics.

The previous figure shows an isometric view of the DES camera, known as DECam. It will have 519 CCD megapixels of a new design, more efficient in the red and near-infrared regions of the spectrum than previous ones. By its size it will mark a new milestone in optical astronomy.

The Spanish groups are involved in the design and fabrication of the front-end pixel readout electronics and its controls. The IFAE group is central to this effort, having built and commissioned in 2006 a cryogenic electronics test bench that will also allow photometric studies of pixel response. The electronics activities of IFAE and the Spanish groups are more fully described further in this report.

On the science side, the IFAE group is strongly involved in the specification of the IA Supernova program as a Dark Energy probe, and in preparing this aspect of data analysis. The group is also participating in other proposals for future projects, as described in the body of the report.

### **THE X-RAY DETECTOR PROJECT**

The Institute also pursues very actively a line of applied research on medical detectors, namely on the development of a digital X-Ray camera giving a high quality image with a very low dose. The detector is intended for mammography and is based on detecting X-rays with a very dense semiconductor. The higher X-ray conversion efficiency of this material allows producing high-quality images with much reduced radiation dose in comparison to conventional radiography.

Semiconductor detectors have long been used in High Energy Physics. The presence at IFAE of scientific and technical personnel with knowledge of these techniques has allowed us to carry out such a project. Acting as the coordinator of 6 European institutions, IFAE submitted an EU research project. The other Spanish institutions include the National Centre for Microelectronics (CNM), also located in the UAB campus, and the Hospital Parc Taulí in Sabadell. The project, with short name DearMama, was funded in late 2000. The principal goal was to produce a complete prototype detector for use in mammography.

This goal has been achieved. An X-ray system was commissioned in 2005 and underwent clinical trials in 2006. The tests were conducted by the team of Dr. M Sentis. The following figure shows a lumpectomy specimen being set up in the Dear-Mama-I machine; the results are shown further in this report.



*A nurse in Hospital Parc Taulí fixing a lumpectomy specimen to the Dear-Mama-I machine.*

The EU project was extended to September 2006 to allow for more complete tests. This matched very well the schedule of a second X-ray machine, based on a further development of the detector technology, which was also built in 2006. Known as Dear-Mama-II, it is devoted to bone radiology and it uses a CdTe pixel detector coupled to photon-counting front-end electronics. Dear-Mama-II is shown in the next figure.

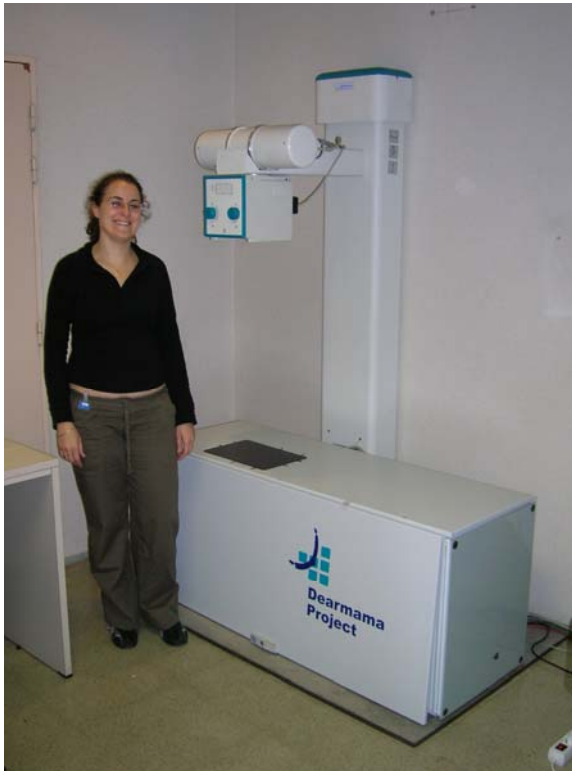

*The Dear-Mama-II machine for bone radiology, completed, installed and ready to be used in UDIAT (Parc Taulí Hospital)*

The higher density of the CdTe detector allows even smaller doses for the same or better performance in terms of image resolution and contrast. More results and comparisons are shown later in the report.

This work has generated a US patent and is being pursued further in a spin-off company, X-ray Imatek SL, created in 2006 with support and encouragement from the Generalitat.

### 3.2 The Theory Division in 2006

The activities of the Theory Division can be classified into three main research lines: quantum information, particle astrophysics, and the physics of fundamental interactions,

#### Quantum Information

Quantum Information is a multidisciplinary research area where quantum physics meets fields as diverse as mathematical statistics, cryptography, computer science, and nanotechnology, among others. Quantum Information employs the laws of quantum mechanics, i.e. the laws of the microscopic world for the efficient processing of certain computational tasks that are intractable within classical physics and modern computers.

The Quantum Information Group (GIQ) brings together researchers attached to the UAB whose work is mainly focused in the field of quantum information and entanglement. GIQ is not an official entity but includes the whole membership of the QUIRT I & II (Quantum Information and Related Topics) projects funded by the Spanish Ministry of Education and Science and the European Thematic Network QUPRODIS IST2002

#### Particle Astrophysics

It is generally recognized that this field, sometimes called either Astroparticles or Particle Cosmology, is in a phase of rapid expansion. One major discovery has been neutrino oscillations, detected from the analysis of atmospheric and solar neutrinos. This is very important for neutrino astrophysics, a field to which we have been contributing for many years.

The general goal of our work is the study of some of the theoretical issues in the physics of elementary particles and their interactions,

particularly in an astrophysical or cosmological medium.

### **Physics of the Fundamental Interactions**

Despite its successes, there are many indications that the SM cannot be complete. We now have experimental evidence that neutrinos have a mass (although we do not know of what kind). Furthermore, we also know that the amount of particle-antiparticle asymmetry in the universe cannot be explained within the SM because it cannot produce enough CP violation. Finally, gravity still resists all attempts to quantize it as we have done with all the other fundamental interactions.

It is very likely that experiments at the LHC will reveal some of the answers to these questions. Our group is devoted to study the physics at the electroweak scale, the origin of mass generation and important discrete symmetries, such as CP. In doing so, concepts such as Supersymmetry, Extra Dimensions or the recent "Unparticle" Physics, but also Precision Flavor Physics and Nonperturbative Strong Interactions play a major role. Finally, we believe that it is important to know about possible implications on particle physics models from cosmology and astrophysics which is also an interesting topic to which we direct our attention.



## 4. ABOUT IFAE

### 4.1 STRUCTURE

The Institut de Física d'Altes Energies (IFAE) is a Consortium between the Generalitat de Catalunya and the Universitat Autònoma de Barcelona (UAB). It was formally created on July 16, 1991, by Act number 159/1991 of the Government of Catalonia (Generalitat de Catalunya). An agreement with the Universitat de Barcelona (UB) allows personnel from that university to participate in scientific program of the Institute. As a Consortium the IFAE is a legal entity with its own "juridical personality". Functionally it depends from the Department of Innovation, Universities and Enterprises (DIUE, formerly DURSI) of the Generalitat.

The IFAE integrates its own personnel with personnel of the Theoretical and Experimental High Energy Physics Groups of the Department of Physics of the UAB. Personnel of the Departments of Structure and Fundamental Constituents of Matter and of Fundamental Physics of UB were also members of the IFAE by means of the agreement between the Institute and UB established in 1992. This agreement was modified in 2003. Under the new terms, the cooperation between the IFAE and the UB will be focused on specific goal-oriented projects. The IFAE is structured in two Divisions: Experimental and Theoretical.

The governing bodies of the Institute are the Governing Board (Consell de Govern) and the Director. The general lines of activity, the hiring of personnel, the annual budget and the creation and suppression of Divisions are among the responsibilities of the Governing Board, which also appoints the Director from a list of candidates nominated by the Rector of UAB. The Director is responsible for the execution of the decisions of the Governing Board. The Coordinators of the Divisions are nominated by

the Director and appointed by the Governing Board.

The Theory Division of the IFAE is formed by most of the members of the theory group of the Physics Department of UAB and, until the end of 2003, of the theoretical particle physicists working at the Faculty of Sciences of UB. All the personnel of the Experimental Division is from IFAE itself or from UAB.

The IFAE has also the status of a "University Institute" attached to UAB. This formula allows the personnel of the IFAE to participate in the educational programme of UAB, in particular in doctoral courses.

### IFAE Goals

As stated in the foundational Act 159/1991 of the Generalitat, the goal of the IFAE is to carry out research and to contribute to the development of both theoretical and experimental High Energy Physics.

The origins of the consortium are in the Department of Theoretical Physics and in the Laboratory for High Energy Physics (LFAE) of UAB. The theoretical group was established in 1971, when the university was founded. The Laboratory for High Energy Physics was created in 1984, in order to start research in experimental high-energy physics at UAB, particularly to use effectively the CERN laboratory, after Spain rejoined the CERN organization in 1982. As mentioned in Act 159/1991 the existence of LFAE and of theoretical research groups in Catalonia, the desire to strengthen research in High Energy Physics, particularly in the experimental side, and the desire to collaborate in the Spanish Government effort to develop this field, led the authorities of the Generalitat to create the IFAE.

## 4.2 GOVERNING BOARD

<b>IFAE GOVERNING BOARD</b>
<b>President</b>
Joaquim Prats Cuevas, Secretary General, DURSI
<b>Members</b>
Xavier Testar i Ymbert, Director General for Research, DURSI
Jordi Marquet Cortés, Vice-Rector for Strategic Projects, U.A.B.
Josep Isern i Sitjà, Director General for Energy, Mines and Industrial Safety, (Dept. of Industry, Tourism and Commerce)
Ramon Pascual de Sans, Professor of Physics, U.A.B.
Joaquim Gomis Torné, Professor of Physics, U.B.

<b>DIRECTOR</b>
<b>Director</b>
Enrique Fernández, Professor of Physics, U.A.B.
<b>Theory Division Coordinator</b>
Eduard Massó, Associate Professor of Physics, U.A.B

## 5. IFAE PERSONNEL

The IFAE complements its own staff (hired directly by the Institute) with personnel of the UAB. Below is a list of the members of the Experimental and the Theory Division of IFAE during 2006.

### EXPERIMENTAL DIVISION

#### Scientific Personnel

Martine Bosman	Inv. Catedràtic (Titular until 8/06), IFAE
Pilar Casado	Prof. Agregada, UAB
Matteo Cavalli-Sforza	Inv. Catedràtic, IFAE
Mokhtar Chmeissani	Inv. Catedràtic (Titular until 8/06), IFAE
Juan Cortina	Inv. Titular (Ramón y Cajal), IFAE
José M. Crespo	Prof. Titular, UAB
Manuel Delfino	Prof. Catedràtic, UAB
Enrique Fernández	Prof. Catedràtic, UAB
Ilya Korolkov	Inv. Titular (Ramón y Cajal), IFAE
Manel Martínez	Inv. Catedràtic, IFAE
Mario Martínez	Inv. Titular (Ramón y Cajal), IFAE
Ramon Miquel (since 9/2006)	Inv. ICREA Senior
Lluïsa Mir (since 9/2006)	Inv. Titular, IFAE
Abelardo Moralejo	Inv. Titular (Ramón y Cajal), IFAE
Cristóbal Padilla (on leave at CERN)	Inv. Titular, IFAE
Inma Riu	Inv. Titular IFAE (Ramón y Cajal), UAB
Federico Sánchez	Inv. Titular IFAE (Ramón y Cajal UAB, until 12/06)

#### Engineering Staff

Georges Blanchot (on leave at CERN)	Enginyer IFAE
Miquel Barceló	Enginyer MAGIC
Jorge García (until 6/2006)	Enginyer Raigs-X
Ferran Grañena (since 6/2006)	Enginyer IFAE
José Ma. Illa (since 6/2006)	Enginyer MAGIC
Carles Puigdemonts	Enginyer ATLAS, Raigs-X
Laia Cardiel	Enginyer IFAE
Joaquim Serra (since 12/2006)	Enginyer Raigs-X

### Scientifics Post-docs

Luca Fiorini (since 7/2006)	ATLAS
Thorsten Lux	Neutrinos
Régis Lefebvre (until 9/2006)	CDF
Marino Maiorino	Raigs-X/DES
Enma de Oña	MAGIC
Monica D'Onofrio	CDF, Postdoc Juan de la Cierva (since 12/06)
Javier Rico	MAGIC, Postdoc Juan de la Cierva
Carlos Sánchez	Raigs-X
Sergei Suskov	ATLAS, Postdoc Juan de la Cierva
Ulrike Blumenschein	ATLAS

### Computer Scientists and Engineers

Andreu Pacheco	IFAE/PIC, Senior Computing Engineer
Marc Campos (since 10/2006)	IFAE
Juli Cespedes	IFAE
Hegoi Garitaonandia	ATLAS
Jaume Tomàs	IFAE

### Doctoral Students

José Alcaraz	Neutrinos (Scholarship MEC-FPI, IFAE)
Ester Aliu	MAGIC (Scholarship Generalitat, UAB)
Alex Armada (until 9/2006)	MAGIC (Scholarship Generalitat, IFAE)
Eva Domingo (until 6/2006)	MAGIC (Project Contract, IFAE)
Manel Errando	MAGIC (Project Contract, IFAE; Teaching Ass. UAB since 9/2006))
Xavier Espinal	Neutrinos (Project Contract, UAB)
Roger Firpo	MAGIC (Scholarship MEC-FPI, IFAE)
Jose Flix (until 7/2006)	MAGIC (Project Contract, IFAE)
Markus Gaug (until 5/2006)	MAGIC (Scholarship MEC-FPU, IFAE)
Sigrid Jorgensen	ATLAS (Scholarship Generalitat, IFAE)
Gabriel Jover	Neutrinos (Scholarship MEC-FPI, UAB)

Javier López (until 8/2006)	MAGIC (Teaching Assistant, UAB)
Carolina de Luca	ATLAS (Scholarship Generalitat, IFAE)
Gianluca de Lorenzo	ATLAS (Project Contract, IFAE)
Olga Normiella	CDF (Project Contract, IFAE)
Federico Nova	Neutrinos (MEC-FPU, UAB)
Carlos Osuna	ATLAS (Scholarship MEC-FPI, IFAE)
Xavier Portell	CDF (Project Contract, IFAE)
Estel Pérez (since 9/2006)	ATLAS (Project Contract, IFAE)
Neus Puchades (since 10/2006)	MAGIC (Project Contract, IFAE)
Ana Rodríguez	Neutrinos (Scholarship MEC-FPI, UAB)
Oriol Saltó	CDF (Scholarship Generalitat, IFAE )
Ester Segura	ATLAS (Scholarship MEC-FPU, IFAE)
Nuria Sidro	MAGIC (Teaching Assistant, UAB; Project Contract since 9/2006 )
Francesc Vives (since 9/2006)	ATLAS (Project Contract, IFAE)
Matteo Volpi	ATLAS (Scholarship Generalitat, IFAE)
Diego Tescaro	MAGIC (Project Contract, IFAE)
Roberta Zanin	MAGIC (Project Contract, IFAE)

### Administrative Personnel

Josep Gaya	IFAE/ UAB, Senior Administrator
Cristina Cárdenas	UAB/ IFAE, Secretary
Natalia Alonso	MAGIC/Raigs-X, Administrative Assistant
Ramon Santos	IFAE, Administrative Assistant

### Technicians

Alex González	Tècnic general IFAE
Javier Gaweda	Tècnic general IFAE
Karl Kölle	MAGIC Telescope Manager

## THEORY DIVISION

### Academic Personnel

Emili Bagan	Prof. Titular, UAB
Marià Baig	Prof. Titular, UAB
Josep Antoni Grifols	Prof. Catedràtic, UAB
Eduard Massó	Prof. Titular, UAB
Antoni Méndez	Prof. Catedràtic, UAB
Ramon Muñoz	Prof. Titular, UAB
Ramon Pascual	Prof. Catedràtic, UAB
Santi Peris	Prof. Titular, UAB
Antonio Pineda	Prof. Titular, UAB
Alex Pomarol	Prof. Titular, UAB
Mariano Quiros	Inv. ICREA Senior
Mathias Jamin	Inv. ICREA Senior

### Research Personnel

Aldo Cotrone	Post-doc IFAE (at UB)
Rafel Escribano	Ramon y Cajal, UAB
Joaquim Matias	Ramon y Cajal, UAB
Gabriel Fernández	Post-doc Juan de la Cierva
Andrea Wulzer	Post-doc IFAE (at UAB)
Pedro Silva	Visiting Scientist
Felix Schwab	Post-doc DFG and BMBF

### Visiting Scientists

S. Mohanty	PRL Ahmedabad, India (since 3/2006)
M. Golterman	S. Francisco State University (02-07/2006)

### Doctoral Students

Santi Béjar	Teaching Assistant
David Diego	Scholarship MEC
Alex Monras	Scholarship MEC
Javier Redondo	Scholarship MEC
Leandro da Rold (until 9/2006)	Scholarship MEC
Gabriel Zsembinski	Scholarship UAB
Oriol Romero	Teaching Assistant
Antonio Picon	Teaching Assistant
Javier Virto	Teaching Assistant
G. Nardini	Scholarship MEC
P. Masjuan (since 02/2006)	Teaching Assistant
J. Serra (since 9/2006)	Scholarship Generalitat

### Administrative Personnel

Montse Cabrera	IFAE/ UAB
----------------	-----------

## 6. INSTITUTIONAL ACTIVITIES

### 6.1 DIPLOMA THESES

#### Experimental Division

**Federico Nova**

Title: *Measurement of the coherent production of pions in the SCIBAR Detector at K2K*  
Supervisor: Federico Sánchez  
Date: 04/07/2006 U.A.Barcelona

**Jose Alcaraz Aunión**

Title: *Study of the Neutrino Background in the T2K near detector*  
Supervisor: Federico Sánchez  
Date: 11/10/2006 U.A.Barcelona

**Sigrid Jorgensen**

Title:  *$\gamma+$  jet in-situ process for validation of the jet reconstruction with the ATLAS detector*  
Supervisor: Martine Bosman  
Date: 10/2006 U.A.Barcelona

**Matteo Volpi**

Title: *Design, implementation and performance of the integrator based system for monitoring DC currents in the Tile Calorimeter of the ATLAS experiment*  
Supervisor: Ilya Korolkov  
Date: 10/2006 U.A.Barcelona

#### Theory Division

**Javier Virto Iñigo**

Title: *On the Phenomenology of  $B \rightarrow KK$  Decays: Flavor symmetries and New Physics*  
Supervisor: Joaquim Matias  
Date: 31/03/06

**Josep Oriol Romero Isart,**

Title: *Parameter estimation of qubit mixed states*  
Supervisor: Emili Bagan  
Date: 03.04.06

### 6.2 DOCTORAL THESES

#### Experimental Division

**Eva Domingo**

Title: *Gamma-ray emission from regions of star formation: Theory and observations with the MAGIC Telescope.*  
Directors: Juan Cortina y Diego Torres  
Date: 03/03/2006

**Josep Flix**

Title: *Observations of gamma-rays from the Galactic Center with the MAGIC Telescope: Indirect searches of supersymmetric dark matter.*  
Director: Enrique Fernández  
Date: 03/05/2006, U. A. Barcelona.

**Markus Gaug**

Title: *Calibration of the MAGIC Telescope and Observation of Gamma Ray Bursts.*  
Director: Manel Martínez  
Date: 22/05/2006, U. A. Barcelona.

**Javier López**

Title: *Measurement of the invariance of the speed of Light observing the active galactic nucleus Mkn421 with the MAGIC Telescope.*  
Director: Manel Martínez  
Date: 26/07/06, U. A. Barcelona.

**Xavier Espinal**

Title: *Measurement of the axial-vector mass in neutrino-carbon interactions.*  
Director: Federico Sánchez  
Date: 01/12/2006, U. A. Barcelona.

#### Theory Division

**Santi Béjar Latonda**

Title: *Flavor changing neutral decay effects in models with two Higgs boson doublets: Applications to LHC Physics*  
Director: Joan Solà Peracaula  
Tutor: Josep Antoni Grifols Gras  
Date: 10/01/2006

**Leandro Da Rold**

Title: *Symmetry breaking in particle physics from extra dimensions*  
Director: Alex Pomarol Clotet  
Date: 6/30/2006

**Zeus Martí Díaz**

Title: *Disseny i caracterització d'un ondulator helicoidal per a la producció de llum de sincrotró, i millores en el seu procés de construcció*  
Director: Josep Campmany Guillot  
Tutor: Ramon Pascual de Sans  
Date: 19/12/2006



## 6.3 PUBLICATIONS

### Experimental Division

#### Publications of the ALEPH Collaboration

*S. Bravo, M.P. Casado, M. Chmeissani, J.M. Crespo, E. Fernández, M. Fernández-Bosman, Ll. Garrido, M. Martínez, A. Pacheco, H. Ruiz with the ALEPH Collaboration:*

- Search for neutral MSSM Higgs bosons at LEP. ALEPH - DELPHI - L3 - OPAL - SLD Collaborations - LEP Working Group for Higgs Boson Searches. S. Schael *et al.* Eur.Phys.J.C47:547-587, 2006.
- Deuteron and anti-deuteron production in  $e^+e^-$  collisions at the Z resonance. S. Schael *et al.* Phys.Lett.B639:192-201, 2006.
- Test of Colour Reconnection Models using Three-Jet Events in Hadronic Z Decays. S. Schael *et al.* Eur.Phys.J.C48:685-698, 2006.
- Measurement of the W boson mass and width in  $e^+e^-$  collisions at LEP. S. Schael *et al.* Eur.Phys.J.C47:309-335, 2006.

#### Publications of the MAGIC group

*E. Aliu, A. Armada, O. Blanch, J. Cortina, E. Domingo, M. Doro, M. Errando, E. Fernández, R. Firpo, J. Flix, M. Gaug, J. Lopez, M. Martínez, E. Oña-Wilhelmi, J. Rico, N. Sidro, with the MAGIC Collaboration:*

- Observation of VHE Gamma-Ray Emission from the Active Galactic Nucleus 1ES1959+650 using the MAGIC Telescope. J. Albert *et al.* Astrophys.J. 639:761-765, 2006.
- MAGIC Observations of Very High Energy g-rays from HESS J1813-178 J. Albert *et al.* Astrophys.J.637:L41-L44, 2006.
- Observation of Gamma-Rays from the Galactic Center with the MAGIC Telescope. J. Albert *et al.* Astrophys.J.638:L101-L104, 2006
- Flux Upper Limit of Gamma-Ray Emission by GRB050713A from MAGIC Telescope Observations. J. Albert *et al.* Astrophys.J.641:L9-L12, 2006

- Discovery of VHE Gamma-Ray Emission from 1ES1218+30.4. J. Albert *et al.* Astrophys.J.642:L119-L122, 2006.
- Observation of VHE Gamma Radiation from HESS J1834-087/W41 with the MAGIC Telescope. J. Albert *et al.* Astrophys.J.643:L53-L56, 2006.
- Variable Very High Energy Gamma-ray Emission from the Microquasar LSI+61 303. J. Albert *et al.* Science 312:1771-1773, 2006.
- Discovery of very high energy gamma-rays from Markarian 180 triggered by an optical outburst. J. Albert *et al.* Astrophys.J.648:105-109, 2006.

*E. Fernández*

- The MAGIC gamma-ray telescope: status and first results (Proceedings of "XIII International Symposium on Very High Energy Cosmic Ray Interactions", Pylos, Greece, 6-12/9/2004). E. Fernández, Nucl. Phys. Proc. Suppl. 151:381-392, 2006

#### Publications of the CDF Group:

*M. Cavalli-Sforza, M. D'Onofrio, R. Lefevre, M. Martínez, O. Norniella, X. Portell, C. Sánchez with the CDF Collaboration:*

- Observation of  $B_0(s)$ - $B_0\bar{0}(s)$  Oscillations A. Abulencia *et al.*, Phys. Rev. Lett. 97, 242003, 2006
- Search for Excited and Exotic Muons in the mu gamma Decay Channel at  $p$  anti- $p$  Collisions at  $s^{**}(1/2) = 1.96$  TeV A. Abulencia *et al.*, Phys. Rev.Lett. 97, 191802, 2006.
- Top Quark Mass Measurement from Dilepton Events at CDF II with the Matrix-Element Method A. Abulencia *et al.*, Phys. Rev. D74, 032009, 2006.
- Observation of  $B_0(s) \rightarrow K^+ K^-$  and Measurements of Branching Fractions of Charmless Two-body Decays of  $B_0$  and  $B_0(s)$  Mesons in  $p$  anti- $p$  Collisions at  $s^{**}(1/2) = 1.96$  TeV A. Abulencia *et al.*, Phys. Rev. Lett. 9, 211802, 2006.
- Measurement of the  $t\bar{t}$  Production Cross Section in  $p$  anti- $p$  Collisions at  $s^{**}(1/2) = 1.96$  TeV using Lepton + Jets Events with Jet Probability b-tagging A. Abulencia *et al.*, Phys. Rev. D74, 072006, 2006.

- Measurement of the  $t\bar{t}$  Production Cross Section in  $p$  anti- $p$  Collisions at  $s^{1/2} = 1.96$  TeV in the all Hadronic Decay Mode  
A. Abulencia et al., Phys. Rev. D74, 072005, 2006.
- Search for Large Extra Dimensions in the Production of Jets and Missing Transverse Energy in  $p$  anti- $p$  Collisions at  $s^{1/2} = 1.96$  TeV  
A. Abulencia et al., Phys. Rev. Lett. 97,171802, 2006.
- Measurement of the  $B_0(s)$ - $B_0\bar{(s)}$  Oscillation Frequency  
A. Abulencia et al., Phys. Rev. Lett. 97, 062003 2006.
- Measurement of the  $t\bar{t}$  Production Cross Section in  $p$  anti- $p$  Collisions at  $s^{1/2} = 1.96$  TeV  
A. Abulencia et al., Phys. Rev. Lett. 97, 082004 2006.
- Search for a Neutral Higgs Boson Decaying to a  $W$  Boson Pair in  $p$  anti- $p$  Collisions at  $s^{1/2} = 1.96$  TeV  
A. Abulencia et al., Phys. Rev. Lett. 97, 081802 2006.
- Measurement of the Ratio of Branching Fractions  $B(D_0 \rightarrow K^+\pi^-)/B(D_0 \rightarrow K^-\pi^+)$  using the CDF II Detector  
A. Abulencia et al., Phys. Rev. D74, 031109, 2006.
- Measurement of the  $b$  Jet Cross Section in Events with a  $Z$  Boson in  $p$  anti- $p$  Collisions at  $s^{1/2} = 1.96$  TeV  
A. Abulencia et al., Phys. Rev. D74, 032008, 2006.
- A Search for  $t \rightarrow \tau \nu q$  in  $t\bar{t}$  Production  
A. Abulencia et al., Phys. Lett. B 639, 172-178, 2006.
- Measurement of the  $B^+_{\text{c}}$  Meson Lifetime Using  $B^+_{\text{c}} \rightarrow J/\psi e^+ \nu_e$   
A. Abulencia et al., Phys. Rev. Lett. 97, 012002, 2006.
- Search for  $Z' \rightarrow e^+ e^-$  Using Dielectron Mass and Angular Distribution  
A. Abulencia et al., Phys. Rev. Lett. 96,211801, 2006.
- Measurement of the  $t\bar{t}$  Production Cross Section in  $p$  anti- $p$  Collisions at  $s^{1/2} = 1.96$  TeV using Missing  $E(t) + \text{jets}$  Events with Secondary Vertex  $b$ -Tagging  
A. Abulencia et al., Phys. Rev. Lett. 96, 202002 2006.
- Search for High-Mass Resonances Decaying to  $e \mu$  in  $p$  anti- $p$  Collisions at  $s^{1/2} = 1.96$  TeV  
A. Abulencia et al., Phys. Rev. Lett. 96, 211802, 2006
- Observation of  $B_0(s) \rightarrow \psi(2S)\phi$  and Measurement of Ratio of Branching Fractions  $B(B_0(s) \rightarrow \psi(2S)\phi)/B(B_0(s) \rightarrow J/\psi \phi)$ .  
A. Abulencia et al., Phys. Rev. Lett. 96, 231801, 2006.
- Measurement of the Top Quark Mass using Template Methods on Dilepton Events in  $p$  anti- $p$  Collisions at  $s^{1/2} = 1.96$  TeV  
A. Abulencia et al., Phys. Rev. D73, 112006, 2006.
- Measurement of the Helicity of  $W$  Bosons in Top-Quark Decays  
A. Abulencia et al., Phys. Rev. D73, 111103, 2006.
- Direct Search for Dirac Magnetic Monopoles in  $p$  anti- $p$  Collisions at  $s^{1/2} = 1.96$  TeV  
A. Abulencia et al., Phys. Rev. Lett. 96, 201801, 2006.
- Measurement of the Top Quark Mass with the Dynamical Likelihood Method using Lepton plus Jets Events with  $b$ -tags in  $p$  anti- $p$  Collisions at  $\sqrt{s} = 1.96$  TeV  
A. Abulencia et al., Phys. Rev. D73, 092002, 2006.
- Measurement of the Ratios of Branching Fractions  $B(B_0(s) \rightarrow D(s)\pi^+)/B(B_0 \rightarrow D\pi^+)$  and  $B(B^+ \rightarrow D\bar{0}\pi^{++})/B(B_0 \rightarrow D\pi^{++})$   
A. Abulencia et al., Phys. Rev. Lett. 96, 191801, 2006.
- Measurement of the Inclusive Jet Cross Section using the  $K_T$  Algorithm in  $p$  anti- $p$  Collisions at  $s^{1/2} = 1.96$  TeV  
A. Abulencia et al., Phys. Rev. Lett. 96, 122001, 2006.
- Top Quark Mass Measurement from Dilepton Events at CDF II  
A. Abulencia et al., Phys. Rev. Lett. 96, 152002, 2006.
- Measurement of the Dipion Mass Spectrum in  $X(3872) \rightarrow J/\psi \pi^+ \pi^-$  Decays  
A. Abulencia et al., Phys. Rev. Lett. 96, 102002, 2006.
- Search for Second-Generation Scalar Leptoquarks in  $p$  anti- $p$  Collisions at  $s^{1/2} = 1.96$  TeV  
A. Abulencia et al., Phys. Rev. D73, 051102, 2006.

- Measurement of Mass and Width of the Excited Charmed Meson States  $D_{0,1}$  and  $D_{0,2}^*$  at CDF  
A. Abulencia et al., Phys. Rev. D73, 051104, 2006.
- Search for Higgs Bosons Decaying to  $b\bar{b}$  and Produced in Association with W Bosons in p anti-p Collisions at  $s^{1/2} = 1.96$  TeV  
A. Abulencia et al., Phys. Rev. Lett. 96,081803, 2006.
- Measurement of the Azimuthal Angle Distribution of Leptons from W Boson Decays as a Function of the W Transverse Momentum in p anti-p Collisions at  $s^{1/2} = 1.8$  TeV  
D. Acosta et al., Phys. Rev. D73, 052002, 2006.
- Search for Anomalous Semileptonic Decay of Heavy Flavor Hadrons Produced in Association with a W Boson at CDF II  
A. Abulencia et al., Phys. Rev. D73, 051101, 2006.
- Search for Charged Higgs Bosons from Top Quark Decays in p anti-p Collisions at  $s^{1/2} = 1.96$  TeV  
A. Abulencia et al., Phys. Rev. Lett. 96, 042003 2006.
- Precision Top Quark Mass Measurement in the Lepton + Jets Topology in p anti-p Collisions at  $s^{1/2} = 1.96$  TeV.  
A. Abulencia et al., Phys. Rev. Lett. 96, 022004 2006.
- Top Quark Mass Measurement Using the Template Method in the Lepton + Jets Channel at CDF II  
A. Abulencia et al., Phys. Rev. D73, 032003, 2006.
- Search for W and Z Bosons in the Reaction p anti-p  $\rightarrow$  2 jets + gamma at  $s^{1/2} = 1.8$  TeV  
D. Acosta et al., Phys. Rev. D73, 012001, 2006.
- Search for Neutral Higgs Bosons of the Minimal Supersymmetric Standard Model Decaying to tau Pairs in p anti-p Collisions at  $s^{1/2} = 1.96$  TeV  
A. Abulencia et al., Phys. Rev. Lett. 96, 011802 2006.

### Publications of the ATLAS Group

*G. Blanchot, M. Bosman, M. Cavalli-Sforza, I. Korolkov, Ll. Miralles, O. Norriella, X. Portell, O. Saltò, with ATLAS TILECAL Collaboration.*  
The ATLAS hadronic tile calorimeter: from construction towards physics  
P. Adragna, et al., IEEE Trans. Nucl. Sci. 53 (2006) 1275-81

*M. Bosman, P. Casado, H. Garitaonandia, C. Osuna, E. Segura, S. Sushkov*  
The ATLAS Data Acquisition and High-Level Trigger : Concept, Design and Status  
B. Gorini et al., ATL-COM-DAQ-2006-030.

*M. Bosman, H. Garitaonandia, E. Segura, S. Sushkov*  
Testing on a Large Scale : Running the ATLAS Data Acquisition and High Level Trigger Software on 700 PC Nodes  
D. Burkhart-Cromek et al., ATL-COM-DAQ-2006-008

### Publications of the Neutrino Group

*E. Aliu, S. Andringa, X. Espinal, E. Fernández, G. Jover, F. Nova, A. Rodríguez, F. Sánchez, with K2K Collaboration*

- An Improved Search for  $\nu(\mu) \rightarrow \nu(e)$  Oscillation in a Long-Baseline Accelerator experiment.  
S. Yamamoto et al. Phys. Rev. Lett. 96:181801, 2006.
- Measurement of the Quasi-Elastic Axial Vector Mass in Neutrino-Oxygen Interactions.  
R. Gran *et al.* Phys. Rev. D74, 052002, 2006
- Measurement of Neutrino Oscillation by the K2K Experiment.  
M.H. Ahn *et al.* Phys. Rev. D74, 072003, 2006

*E. Fernández*  
Neutrino Physics at Accelerators  
Journal of Physics: Conference Series, 53 (2006) 83-106.

*E. Fernández*  
Neutrino Physics and Astrophysics  
New Worlds in Astroparticle Physics, Edited by Ana M. Mourao et al., World Scientific, ISBN 981-256-625-2, 2006.

*F. Sánchez*  
Prospects of Neutrino Physics  
PoS HEP2005:408, 2006.

*F. Sánchez for K2K Collaboration*  
Search for Neutrino-Induced Charged Current Coherent Pion Production with Carbon in a 1.3-GeV Wide Band Muon Neutrino Beam.  
Nucl. Phys. Proc. Suppl. 155:239-241, 2006.

*J. Alcaraz, S. Andringa, X. Espinal, G. Jover, T. Lux, F. Nova, A.Y. Rodríguez, F. Sánchez, with SciBoone Collaboration*  
Bringing the SciBar Detector to the Booster Neutrino Beam.

hep-ex/0601022

*T. Lux for the T2K TPC groups*

A TPC for the Near Detector at T2K

Proceedings, 3rd TPC Symposium, Paris, France, Dec. 2006

*J. Alcaraz, A. Cervera, P. Bene, A. Blondel, D. Ferrere, G.V. Jover, T. Lux, F. Masciocchi, F. Nova, E. Perrin, J-P. Richeux, A.Y. Rodríguez, F. Sánchez and R. Schroeter*  
Detailed Performance Studies of a Large GEM-TPC Prototype

Proceedings, IEEE, San Diego, USA, Nov. 2006

### Publications of the X-Ray Group

*G. Blanchot, M. Chmeissani, J. García, M. Maiorino, C. Puigdemogles, et al.*

- Dear-Mama: A photon counting X-ray imaging project for medical applications  
Nuclear Instruments and Methods in Physics Research Section A: Volume 569, Issue 1, 10 December 2006, Pages 136-139.
- A read-out system for the Medipix2 chip capable of 500 frames per second.  
Nuclear Instruments and Methods in Physics Research Section A: Volume 563, Issue 1, 1 July 2006, Pages 96-99.
- Charge-sharing observations with a CdTe pixel detector irradiated with a  $^{57}\text{Co}$  source  
Nuclear Instruments and Methods in Physics Research Section A: Volume 563, Issue 1, 1 July 2006, Pages 177-181.

### Other Publications

*R. Miquel with A. G. Kim*

Optimal Extraction of Cosmological Information from Supernova Data in the Presence of Calibration Uncertainties  
Astropart. Phys. 24, 451, 2006.

*R. Miquel with Particle Data Group*

Review of Particle Physics  
W.M.Yao et al., J. of Phys. G 33, 1, 2006.

*I. Riu and F. Sánchez with HERAB Collaboration:*

- Polarization of Lambda and anti-Lambda in 920-GeV fixed-target proton-nucleus collisions.  
Phys.Lett.B638:415-421, 2006.

- Measurement of the Upsilon production cross-section in 920-GeV fixed-target proton-nucleus collisions.  
Phys.Lett.B638:13-21, 2006.
- Improved measurement of the b-anti-b production cross section in 920-GeV fixed-target proton-nucleus collisions  
Phys.Rev.D73:052005, 2006.
- Measurement of the J/psi production cross section in 920-GeV/c fixed-target proton-nucleus interactions.  
Phys.Lett.B638:407-414, 2006.

### Theory Division

*E. Bagan, M.A. Ballester, R.D. Gill, A. Monras, R. Muñoz-Tapia*

Optimal full estimation of qubit mixed status  
Phys. Rev. A 73, 032301 (2006)

*E. Bagan, M. A. Ballester, R. D. Gill, R. Muñoz-Tapia, O. Romero-Isart*

Separable Measurement Estimation of Density Matrices and its Fidelity Gap with Collective Protocols  
Phys. Rev. Lett. 97, 130501 (2006)

*E. Bagan, R. Muñoz-Tapia*

Aligning Spatial Frames Through Quantum Channels  
Int. J. Quant. Inf. 4, 5 (2006)

*Alex Monras*

Optimal phase measurements with pure Gaussian status  
Phys. Rev. A 73, 033821 (2006)

*C. Rodo, O. Romero-Isart, K. Eckert and A. Sanpera*  
Efficiency in Quantum Key Distribution Protocols with Entangled Gaussian States  
Aceptado en "Open Systems & Information Dynamics", Springer Publisher ISSN 1230-1612 (Print) 1573-1324 (Online).

*A. Bramon, R. Escrivano, G. Garbarino*

Bell's inequality tests with meson-antimeson pairs  
Found. Phys. 36 (2006) 563-584.

*R. Escrivano*

Scalar and vector meson exchange in  $V \rightarrow P^0 P^0 \gamma$  decays  
Phys. Rev. D 74 (2006) 114020

*R. Escrivano*

Short study of the eta-eta' system in the two mixing angle scheme  
PoS HEP2005 (2006) 418

- R. Escribano*  
Phenomenological test of the large  $N_c$  ChPT predictions for the pseudoscalar mixing parameters  
Acta Phys. Polon. B 37 (2006) 837
- M. Jamin et al.*  
Scalar K pi form factor and light quark masses  
Phys. Rev. D 74 (2006) 074009.
- M. Jamin et al.*  
Spectral distribution for the decay  $\tau \rightarrow \nu_\tau K \pi$   
Phys. Lett. B 640 (2006) 176.
- S. Peris et al.*  
On the relation between low-energy constants and resonance saturation  
Phys. Rev. D 74 (2006) 096002.
- S. Peris*  
Large- $N_c$  QCD and Pade Approximant Theory  
Phys. Rev. D 74 (2006) 054013.
- S. Peris et al.*  
The operator product expansion does not imply parity doubling of hadrons  
Phys. Rev. D 74 (2006) 016001.
- M. Quiros et al.*  
Dark matter candidates in a baryogenesis inspired scenario  
J. Phys. Conf. Ser. 39 (2006) 173
- M. Quiros et al.*  
Dark matter in split extended supersymmetry  
Journal of Cosmology and Astroparticle Physics 12 (2006) 007
- M. Quiros*  
The MSSM from Scherk-Schwarz supersymmetry breaking  
Phys. Rev. D 74 (2006) 055004
- M. Quiros et al.*  
Split Extended Supersymmetry from Intersecting branes  
Nucl. Phys. B 744 (2006) 156
- M. Quiros et al.*  
Splitting Extended Supersymmetry  
Phys. Lett. B 634 (2006) 302
- J. Matias, J. Virto et al.*  
 $B_0(s) \rightarrow K^+ K^-$  and  $B_0(s) \rightarrow K_0 \text{ anti-}K_0$  Decays within Supersymmetry.  
Published in JHEP 0612:019, 2006.
- J. Matias, J. Virto et al.*  
Exploring  $B(d,s) \rightarrow KK$  decays through flavour symmetries and QCD factorisation.  
Phys.Rev.Lett.97:061801, 2006.
- J. Matias, J. Virto et al.*  
Supersymmetric contributions to  $B_0(S) \rightarrow K^+ K^-$   
JHEP0602:027, 2006.
- A. Pomarol, L. Da Rold,*  
The Scalar and pseudoscalar sector in a five-dimensional approach to chiral symmetry breaking  
JHEP 0601:157, 2006.
- A. Pomarol, L. Da Rold et al.*  
A Custodial symmetry for Zb anti-b  
Phys.Lett.B641:62-66, 2006.
- P. Silva*  
Thermodynamics at the BPS bound for Black Holes in AdS  
JHEP 0610:022, 2006.
- J.A. Grifols*  
Scalar Dark Matter and Stability of Cold Stars  
Astropart. Phys 25 (2006) 98
- A. Dupays, E. Massó, J. Redondo and C. Rizzo*  
Light scalars coupled to photons and non-newtonian forces  
arXiv:hep-ph/0610286
- P. Q. Hung, E. Massó and G. Zsembinszki*  
Low-scale inflation in a model of dark energy and dark matter  
JCAP 0612 (2006) 004
- E. Massó and J. Redondo*  
Axion results: What is new?  
AIP Conf. Proc. 878 (2006) 387
- E. Massó, S. Mohanty and G. Zsembinszki*  
Was the universe open or closed before inflation?  
arXiv:astro-ph/0609349
- E. Massó*  
Axions and their relatives  
arXiv:hep-ph/0607215.
- E. Massó and J. Redondo*  
New results in axion physics  
arXiv:hep-ph/0606164.

*E. Massó and J. Redondo*  
Compatibility of CAST search with axion-like interpretation of PVLAS results  
Phys. Rev. Lett.97 (2006) 151802

*C. Biggio, E. Massó and J. Redondo*  
Mixing of photons with massive spin-two particles in a magnetic field  
arXiv:hep-ph/0604062.

*E. Massó and G. Zsembinszki*  
Unified model for inflation and dark energy with Planck-scale pseudo-Goldstone bosons  
JCAP 0602 (2006) 012.

*J. Matias*  
The Angular distribution of  $B^0 \rightarrow K^*0(\rightarrow K^- \pi^+)l^+ l^-$  at large recoil in and beyond the SM.  
Published in PoS HEP2005:281, 2006.

## 6.4 TALKS GIVEN BY IFAE MEMBERS

### Experimental Division

#### **Matteo Cavalli-Sforza**

*Summary talk of Astroparticle Physics session*  
Open Symposium on European Strategy for Particle Physics  
LAL, Orsay (France), February 2006.

*Interim report from Zero Degree Calorimeter Light review*  
ATLAS Review Week, Plenary session  
Stockholm University (Sweden), July 2006

*Status of the Zero Degree Calorimeter and its Lol*  
ATLAS Review Week, Plenary session  
CERN, Geneva (Switzerland), October 2006

*Partículas elementales, Cosmología y Astrofísica: ¿qué se prepara?*  
Facultad de Física, Universidad de Valencia, November 2006.

#### **Enrique Fernández**

*Cataclismos Cósmicos*  
Ciclo de Conferencias de la Real Academia de Ciencias dentro del Programa de Difusión de la Cultura Científica.  
Univ. de Zaragoza, Facultad de Ciencias, 2/3/2006

Universidad CEU, Tabernes, Valencia, 7/3/2006  
Casa de las Ciencias, Logroño, 9/3/2006  
Diputación de Castilla-La Mancha, Toledo, 20/4/2006.

*Neutrinos del Sol.*  
Ciclo de Conferencias Ciencia de la Real Academia de Ciencias Exactas Físicas y Naturales.  
Real Academia, Madrid (Spain), March 2006.

*Inter-regional Cooperation: the experience of PaNAGIC.*  
General Aspera Meeting,  
Valencia (Spain), November 2006.

#### **Ilya Korolkov**

*TileCal Plans for the sLHC Upgrade.*  
ATLAS Upgrade Workshop  
CERN, Geneva (Switzerland ), October 2006.

*TileCal Electronics Calibration.*  
ATLAS Calorimeter Calibration Workshop  
Sant Feliu, Costa-Brava (Spain), September 2006.

*Front-End Electronics of Tile Calorimeter and its commissioning.*  
CALOR06, XII International Conference on Calorimetry in High Energy Physics  
Kellogg School of Management, Chicago (USA), June 2006.

#### **Serge Sushkov**

*TDAQ developments for calibration*  
ATLAS Calorimeter Calibration Workshop  
Sant Feliu, Costa-Brava (Spain), September 2006.

#### **Sigrid Jorgensen**

*In situ calibration with Z/gamma+jets*  
ATLAS Calorimeter Calibration Workshop  
Sant Feliu, Costa-Brava (Spain), September 2006.

*Jet Reconstruction and Calibration in the ATLAS Calorimeters*  
CALOR06, XII International Conference on Calorimetry in High Energy Physics  
Kellogg School of Management, Chicago (USA), June 2006.

**Hegoi Garitaonandia**

*Worm and Peer To Peer Distribution of ATLAS Trigger & DAQ Software to Computers*

Computing in High Energy and Nuclear Physics  
T.I.F.R. Mumbai, (India), February 2006.

**Pilar Casado**

*Triggering on hadronic taus: plans&performance studies in ATLAS/CMS*

Workshop on prospects for charged Higgs discovery at Colliders-2006  
Uppsala University (Sweden), September 2006.

**Juan Cortina**

*First cycle of MAGIC galactic observations*

4th Workshop on Science with the New Generation of High Energy Gamma-ray Experiments  
Elba Island (Italy), 20 - 22 June 2006.

*Status and recent results of MAGIC*

Locating PeV Cosmic-Ray Accelerators: Future Detectors in Multi-TeV Gamma-Ray Astronomy  
Adelaide (Australia), 6-8 December 2006.

**Manel Martínez**

*The MAGIC Telescopes*

RENATA 06.

Cullera, Valencia (Spain), October 2006.

*The DES instrument project*

SIDE Kick of Meeting.

Granada (Spain), September 2006

*The MAGIC Telescopes and beyond*

SEA 06.

Barcelona (Spain), September 2006.

*Cosmology with VHE Gamma Ray Telescopes*

IRGAC 2006

Barcelona (Spain), July 2006.

*Cosmology and VHE Gamma Ray astrophysics: connections and perspectives.*

The multi-messenger approach to unidentified Gamma-Ray sources

(Third Workshop on the Nature of Unidentified High-Energy Sources).

Barcelona (Spain), July 2006.

*Status of VHE gamma-ray astronomy observations.*

Hot topics in Astrophysics and Cosmology: A new age

for Ground-Based Observations.

Barcelona (Spain), May 2006.

*DECam FEE panel Interim Report*

DES Collaboration meeting.

Barcelona (Spain), May 2006.

**Javier Rico**

*First Results of Galactic Observations with MAGIC.*

XII International Workshop on Neutrino Telescopes.  
Venice (Italy), March 2007.

*Discovery of the gamma-ray binary LS I +61 303 at very high energy gamma-rays*

Workshop on the keV to TeV connection.

Rome (Italy), October 2006.

*Results from the first observation cycle with MAGIC*

Microquasars and Beyond.

VI Microquasar Workshop.

Como (Italy), September 2006.

*Results from MAGIC's first observation cycle on Galactic sources*

The Multimessenger Approach to Unidentified Gamma-ray Sources.

III Workshop on the Nature of Unidentified High-Energy Sources.

Barcelona (Spain), July 2006.

*La astronomía de altas energías y el telescopio MAGIC*

Facultad de Ciencias Físicas. Universidad Complutense.

Madrid (Spain), November 8th, 2006.

*Discovery of the microquasar LS I +61 303 at TeV energies*

Departamento de Física Teórica y del Cosmos.

Instituto Astrofísico de Andalucía, Granada (Spain), June 23, 2006.

Universidad de Granada, Granada (Spain) June 26, 2006.

**Nuria Sidro**

*Discovery of microquasar LS I +61 303 at very high energy gamma-rays with MAGIC.*

VII reunion científica de la SEA 2006

Barcelona (Spain), 12-15 September 2006

*Discovery of the microquasar LS I +61 303 at VHE gamma-rays with MAGIC*

VI Microquasar Workshop: Microquasars and Beyond

Como (Italy), September 18-22, 2006.

## **Federico Sánchez**

*Neutrino Cross-Sections (Experiments)*  
Neutrino Oscillation Workshop (NOW) 2006  
Otranto (Italy), September 2006.

*Neutrinos, una historia experimental*  
Cursos de verano de la Universidad Internacional  
Menéndez y Pelayo  
Santander (Spain), September 2006.

*From K2K to T2K, prospects of atmospheric neutrino oscillation in Japan*  
Universitat de Barcelona (Spain), March 2006.

*Resolution with the European GEM T2K-TPC prototype*  
ILC TPC Analysis Jamboree  
DESY Hamburg (Germany), February 2006.

## **Thorsten Lux**

*A TPC for the near detector at T2K*  
3rd TPC Symposium  
Paris (France), December 2006.

*Detailed Performance Studies of a Large GEM-TPC Prototype*  
IEEE conference  
San Diego (USA), November 2006.

*A GEM readout for the T2K TPC*  
Technical Recommendation Meeting  
KEK Tsukuba (Japan), January 2006.

## **Federico Nova**

*Pattern recognition in Nemo3 and SuperNemo: preliminary ideas*  
NEMO/SUPERNEMO Collaboration meeting  
Jaca (Spain), December 2006.

## **Ramon Miquel**

*Cosmology with type-Ia supernovae*  
2nd International Conference on Quantum Theories and Renormalization Group in Gravity and Cosmology (IRGAC 2006)  
Barcelona (Spain) July 2006.

## **Monica D'Onofrio**

*Jet Properties at the Tevatron*  
XIX Rencontres de Physique de la Vallée d'Aoste  
La Thuile (Italy), March 2006.

*Search for New Physics in Jets+MET Final States at CDF*  
International Meeting on Fundamental Physics, IMFP06  
Madrid (Spain), April 2006.

## **Oriol Saltó**

*Study of Hadronic Final States in Z Production in Searches for Monojet Signatures at the Tevatron*  
American Physical Society Meeting, Dallas, (USA), April 2006.

## **Xavier Portell**

*Search for Squark and Gluino Production in Multiple Jets plus MET Final States at the Tevatron*  
American Physical Society Meeting, APS Meeting  
Dallas (USA), April 2006.

*Supersymmetry Searches at the Tevatron*  
Hadron Collider Physics Conference  
Duke University (USA), May 2006.

## **Régis Lefèvre**

*Inclusive Jet Production using the kT algorithm at CDF*  
QCD (QCD 06)  
Montpellier (France), July 2006.

*Inclusive Jet Production using the Kt algorithm at CDF*  
International Meeting on Fundamental Physics, IMFP06  
Madrid (Spain), April 2006.

## **Olga Noriella**

*Inclusive Jet Cross section at the Tevatron*  
Deep Inelastic Scattering Workshop  
Tsukuba (Japan), April 2006.

## **Mario Martínez**

*Search for Squark/Gluino Production in CDF*  
SUSY06  
Irvine (USA), June 2006.

*High Pt Jet Physics*  
Physics in Collision 2006  
Brazil, July 2006.

## **Mokhtar Chmeissani**

*Dear-Mama, a photon counting X-ray machine*  
ECR2006  
Vienna (Austria), March 2006.



## **Theory Division**

### **E. Bagan**

*Informació Quàntica: Computació, comunicació, criptografia.*, al III Mil·lenni  
Univ. Illes Balears, Palma de Mallorca (Spain), March 2006.

*Optimal estimation of quantum states and some applications to communication.*  
Univ. Illes Balears, Palma de Mallorca (Spain), March 2006.

*Local vs. Collective Measurements in Quantum State Estimation and Discrimination.*  
QUPREST 2006. Focus Meeting: Quantum Process Estimation  
Budmerice (Slovakia), September 2006.

*Multiple-copy Mixed State Discrimination: The Quantum Chernoff Bound.*  
Univ. Complutense, Madrid (Spain), November 2006.

### **R. Muñoz-Tapia**

*Quantum directions*  
Univ. Complutense  
Madrid (Spain), 30 May 2006.

*Quantum Information and some open mathematical problems.*  
2nd Czech-Catalan Conference in Mathematics.  
Institut d'Estudis Catalans  
Barcelona (Spain), September 2006.

### **R. Escribano**

*$\eta$ - $\eta'$  mixing at LNF: status and prospects*  
Meeting on  $e^+e^-$  physics perspectives at LNF.  
Frascati (Italia), January 2006

*Scalar and vector meson exchange in  $V \rightarrow P^0 P^0 \gamma$  decays*  
QNP06 IVth International Conference on Quarks and Nuclear Physics  
Madrid (Spain), June 2006

### **E. Massó**

*Axions and their relatives*  
Workshop on High Energy Physics Phenomenology  
Bhubaneswar (India), 2006

*New results in axion physics*  
20th Rencontres de Physique de la Vallée d'Aosta  
Frascati Physics Series  
La Thuile (Italy), 2006.

*Axion results: What is new?*  
The dark side of the universe  
American Institute of Physics, AIP Conf.Proc.878:387-394, 2006  
Madrid (Spain). 2006

*Cosmología de partículas*  
Taller de Altas Energías (TAE)  
Santander, (Spain), 2006

*Astrophysical constraints at the light of the PVLAS axionlike particle*  
Modern Cosmology: Inflation, CMB and LSS  
Benasque (Spain), 2006.

*PVLAS and the stars*  
PVLAS open day  
Trieste (Italy), 2006.

*Axion Physics, what is new?*  
2nd Joint ILIAS-CAST-CERN axion Training Workshop  
2006  
Patras, (Greece), 2006.

*Astrophysical constraints in the light of the PVLAS axion-like particle*  
Workshop on Axions at the Institute for Advanced Studies, Princeton (USA), 2006.

### **J. Matias**

*Precise New Physics Observables in  $B_0 \rightarrow K^*0 l+l-$* ,  
LHCb-meeting  
Theory Division, CERN (Switzerland), March 2006.

*Merging Flavour Symmetries with QCD in  $B_s \rightarrow KK$  decays*  
Final Euridice Conference  
Kazimierz (Poland), August 2006.

*$B_s \rightarrow K+K-$  and  $B_s \rightarrow K0K0$  using QCD and Flavour Symmetries*  
Super-B Conference  
Villa Mondragone, Frascati (Italy), November 2006.

*$B_d \rightarrow KK$  Decays: Theory*  
Theory Division, CERN, December 2006.

**S. Peris***Lessons from large- $N_c$  QCD*

Talk given at the Conference on High Energy Physics in the LHC Era

Valparaíso (Chile), December 2006.

**A. Pineda***Hybrid potentials versus gluon lumps*

Quark Confinement and the Hadron Spectrum VII  
Azores (Portugal), 2006.

*Top-antitop production near threshold with PNRQCD*

International Linear Collider (ILC) Workshop  
Valencia (Spain), 2006.

**M. Quiros***Electroweak Symmetry Breaking with extra dimensions*

Plenary Session in "High Energy Physics in the LHC Era: Theoretical and Experimental perspectives".  
Paris (France), November 2006.

*Electroweak Baryogenesis*

Plenary session in "2nd International on Quantum Theories and Renormalization Group in Gravity and Cosmology: IRGAC 2006"  
Cosmocaixa, Barcelona (Spain), July 2006.

*The MSSM from extra dimensions*

Plenary session in "30th Johns Hopkins Workshop on Current problems in Particle Theory: Where do we go from the Standard Model?"  
Florence (Italy), June 2006.

*Electroweak breaking from extra dimensions*

Plenary session in "From the Planck scale to the Electroweak scale": ninth european meeting  
Paris (France), May 29th-June 2nd 2006.

*The MSSM from SS breaking*

HEP2006: "Recent developments in High Energy Physics and Cosmology"  
Ioannina (Greece), April 2006.

*Introduction extra dimensions*

XL1st Rencontres de Moriond, "Electroweak Interactions and Unified Theories"  
La Thuile, Aosta Valley, (Italy), March 2006.

*Electroweak Baryogenesis*

2006 Aspen Winter Conference on Particle Physics  
"Particle Physics at the Verge of Discovery"  
12-18 Feb. 2006

*Electroweak breaking from extra dimensions*

Talk given at the University of Valencia,  
Valencia (Spain), May 2006.

*Radion stabilization in de Sitter space-time*

IFT/UAM  
Madrid (Spain), April 2006.

**J. A. Grifols***Scalar dispersion forces, BE condensation and scalar Dark Matter*

High Energy Physics in the LHC Era, International Workshop.  
Valparaíso (Chile), December 2006.

**M. Jamin** *$|V_{us}|$  from strange hadronic tau data*

33rd Int. Conf. on High Energy Physics (ICHEP 06),  
Moscow (Russia), 26 Jul - 2 Aug 2006.

**6.5 PARTICIPATION IN EXTERNAL COMMITTEES****Martine Bosman:**

- ATLAS Speakers committee.  
Elected by ATLAS Collaboration Board. From July 2005 to June 2008.  
Member July 2005 to June 2007 – Chair July 2007-June 2008.

**Matteo Cavalli-Sforza:**

- CERN Scientific Policy Committee.  
Member. Appointed by CERN Council. Since September 2002.
- CERN Council's Strategy Group: Preparatory Group.  
Member. Appointed by CERN Council, September 2005 – July 2006.
- Member of Conseil scientifique du LPNHE - Laboratoire de Physique Nucléaire et de Hautes Energies, CNRS et Universités de Paris 6 et de Paris 7  
Appointed by Director of LPNHE, 2005 - 2008
- Chairman of Scientific Committee of the Laboratori Nazionali di Frascati of INFN  
Appointed by President of INFN, 2006-2009

**Enrique Fernández:**

- CERN Scientific Policy Committee. Member. Appointed by CERN. Council. Since January 2005.
- Particle and Nuclear Astrophysics and Gravitational International Committee (PANAGIC). Chair, since August 2005, nominated by IUPAP. Member since October 2000.
- Peer Review Committee of ApPEC (Astroparticle Physics European Coordinating Committee). Member: nominated by ApPEC Steering Committee. Since January 2001.
- Interim Scientific Policy Committee of the "Laboratorio Subterráneo de Canfranc". Member; appointed by Secretary General of the Spanish Ministry of Education. 2005-2006.
- Member of SISE (Sistema Integral de Seguimiento y Evaluación) Committee for High Energy Physics Program Member; appointed by General Director for Research of the Spanish Ministry of Education. 2005-2006.
- Member of CVI (Comitato de Valutazione Interna) of the INFN. Appointed by Director of INFN (Italy). 2006-.
- Member International Advisory Board of the Henderson-DUSEL National Underground Laboratory. Appointed by Head of Henderson-DUSEL Initiative. State University of New York at Stony Brook.

**Ilya Korolkov:**

- Luminosity Task Force of ATLAS TileCal Representative. Appointed by TileCal Project Leader. From April 2005.
- Tile Calorimeter Institute Board Member. Nominated by IFAE/ATLAS group From August 2004.

**Mario Martinez:**

- Member of LHCC Committee at CERN since January 2005. Appointed by Director General of CERN.

**Juan Cortina**

- MAGIC Executive Board: Technical Coordinator of the MAGIC Collaboration, from October 2005 to November 2006.
- IAC CCI Observations Subcommittee: member nominated by MAGIC Executive Board, from October 2005 to November 2006.

**Manel Martínez**

- MAGIC Steering Committee. Spokesperson for MAGIC Collaboration: appointed by MAGIC Steering Committee.
- Finance Subcommittee of Instituto de Astrofísica de Canarias. Member: appointed by MAGIC Steering Committee. Since January 2001.

**Abelardo Moralejo**

- MAGIC Executive Board: Software Coordinator of the MAGIC Collaboration, since November 2006

**Manuel Delfino:**

- Member of the "Grupo de interés español sobre Grid y e-Ciencia (IRISGrid)." Since 2002.
- Member of the International High Energy Physics Computing Coordination Committee (IHEP-CCC). Since 2004.
- Member Subcommittee ICFA International High Energy Physics Computing Coordination Committee. Since 2004.
- Coordinator for Spain and Portugal of the Executive Committee of the project Enabling Grids for E-Science in Europe (UE) Framework VI Project). Since 2003.

- Elected Member of the Project Overview Board - LHC Computing Grid Project (CERN). Since 2003.
- Representante de España en el Comité de Implementación del LHC Computing Grid (CERN). Since 2002.

#### **Andreu Pacheco**

- Member of the Collaboration Board of the project Enabling Grids for E-Science in Europe (UE Framework VI Project). Since 2004.
- Member of the LCG Grid Deployment Board (CERN). Since 2004.
- Member of the Atlas International Computing Board (CERN). Since 2003.

#### **Georges Blanchot**

- Currently at CERN. Chief engineer in charge of cabling, grounding and electromagnetic interference matters for ATLAS Since 2004.

### **6.6 SEMINARS ORGANIZED BY IFAE**

#### **Ll. Masanes**

Univ. Bristol

*All entangled states are not simulatable by classical correlations*

January 2006

#### **D. Belyaev**

DESY, Germany

*Supersymmetry with and without boundary conditions*

27/01/2006

#### **F. Feruglio**

Univ. di Padova, Italia

*Discrete symmetries of lepton mixing angles*

30/01/2006

#### **J. Korbicz**

Hannover/ ICFO

*Potential application of group theory in entanglement theory*

03/02/2006

#### **A. Wulzer**

IFAE

*The Higgs as a Wilson Line Phase*

10/02/2006

#### **R. Demkowicz-Dobrzansk**

Center for Theoretical Physics, Warsaw, Poland

*State Estimation on correlated copies*

23/02/2006

#### **O. Pujolas**

Center for Cosmology and Particle Phys., New York University

*Do mini Black Holes escape from the brane?*

17/03/2006

#### **A. Polosa**

INFN, Sezione di Roma, Italy

*4-quark states?*

24/03/2006

#### **P. Sikivie**

University of Florida and CERN

*Cold dark matter caustics*

31/03/2006

#### **A. Cabello**

Universidad de Sevilla

*Bell inequalities based on equalities*

3/04/2006

#### **W. Wootters**

Williams College, USA

*Optimal Discrimination among Product States*

3/04/2006

#### **W. Wootters**

Williams College, USA

*Picturing Qubits in Phase Space*

6/04/2006

#### **Y. Shamir**

Tel Aviv Univ.

*Lattice QCD with domain wall fermions*

21/04/2006

#### **J. Santiago**

Fermilab

*Revamped Braneworld Gravity*

28/04/2006

**J. Bernabeu**

University of Valencia  
*Monochromatic neutrino beams and CP violation in neutrino oscillations*  
02/05/2006

**C. Boehm**

CERN (Geneve) and LAPTH (Annecy)  
*Viability and detectability of light dark matter particles*  
05/05/2006

**S. Barnett**

University of Strathclyde  
*Optimal quantum measurements: from minimum error to maximum confidence*  
16/05/2006

**S.D. Odintsov**

IEEC and ICREA, Barcelona  
*Introduction to modified gravity as gravitational alternative for dark energy*  
19/05/2006

**E. Rico Ortega**

University of Innsbruck  
*Scale perturbation in valence bond ground states*  
29/05/2006

**A. Pineda**

U. Barcelona  
*Heavy meson semileptonic differential decay rate in two dimensions in the large  $N_c$*   
02/06/2006

**F. Schwab**

TU Munich, Germany  
*Signatures of CP Violating Electroweak Penguins in Flavor Physics*  
09/06/2006

**S. Pospescu**

University of Bristol  
*Entanglement and the foundations of statistical mechanics*  
13/06/2006

**M. A. Martin-Delgado**

Universidad Complutense de Madrid  
*Topological quantum computation and condensed matter*  
29/06/2006

**C. Bernard**

Washington Univ.  
*Simulations of QCD with Staggered Quarks: Results and Issues*  
30/06/2006

**M. Casas**

Universitat de les Illes Balears  
*Maximum entangled mixed states and the speed of quantum evolution*  
04/07/2006

**X. Calmet**

Univ. Libre de Bruxelles  
*Naturalness, Hierarchy and Physics Beyond the Standard Model*  
05/10/2006

**G. Molina-Terriza**

ICFO  
*Exploring high dimensional spaces (with the transversal shape of photons)*  
20/10/2006

**J. Taylor**

Massachusetts Institute of Technology  
*Quantum control of coupled spins in a mesoscopic environment*  
25/10/2006

**O. Kittel**

Bonn  
*How light can the lightest Neutralino be?*  
03/11/2006

**E. Passemar**

LPT Orsay  
*Searching new physics with a non decoupling effective theory*  
06/11/2006

**C. Paus**

M.I.T.  
 *$B_s$  Results from the Tevatron*  
10/11/2006

**A. S. Joshipura**

Physical Research Laboratory, Ahmedabad, India  
*Ideas on Unified Description of Quark and Leptonic Mixing*  
12/12/2006

**G. Birkl**

TU Darmstadt  
*Micro traps for quantum information processing*  
15/12/2006

**J. Papavassiliou**

Univ. Valencia  
*Dynamical gluon mass generation and the QCD coupling constant*  
24/11/2006

**M. Perez-Victoria**

CERN

*Reconstructing Migdal's Holograms*

28/11/2006

**D. Porrás**

Max-Planck-Institut

*Studying spin chain models with matrix product states and DMGR*

01/12/2006

**J.-M. Frère**

Univ. Libre de Bruxelles

Mass

01/12/2006

**B. Paredes**

Uni. Mainz

*Exploiting quantum parallelism to simulate many-body quantum random systems*

15/12/2006

**P. Horodecki**

U. of Gdansk

*Unifying classical and quantum key distillation*

15/12/2006

**S. Nussinov**

Tel Aviv University

*New Aspects and variants of the Casimir effect*

20/12/2006

**P. Talavera**

UPC

*Relativistic Heavy ion collisions and string theory*

22/12/2006

**G. Rowell**

MPIK Heidelberg

*H.E.S.S. Observations*

31/01/06

**A. Hicheur**

Rutherford Appleton Laboratory

*Production for High momentum eta' in B decays and surrounding issues*

27/02/06

**K. Neuffer**

INTA-CSIC

*Proyectos Grid en el centro de Astrobiología y futuras aplicaciones*

10/03/06

**F. Orellana**

(Grid coordinator of the Geneva ATLAS group)

*ATLAS use cases in Grid computing*

23/03/06

**M. D'Onofrio**

IFAE

*Boson + jets production and the search for new physics*

08/05/06

**A. Ruiz**

ICFA

*B physics at CDF*

12/05/06

**W. Bednarek**

Univ. of Lodz

*Gamma-rays and neutrinos from different types of massive binary systems*

23/05/06

**O. Blanch**

LPNHE, Paris

*The Pierre Auger Observatory and ultra high energy neutrinos*

29/06/06

**Y. Kemp**

*Computing in High-Energy-Physics, how virtualization meets the Grid*

23/10/06

## 7. SCIENTIFIC ACTIVITIES

### THE EXPERIMENTAL DIVISION

The Experimental Division of IFAE is involved in several research programs in High Energy Physics and in Astrophysics and Cosmology; in applied research focused on the development of Detectors for Medical Applications and in Data Intensive Scientific Computing.

The IFAE is a member of the ATLAS Collaboration, which has built one of the two general-purpose detectors for the flagship CERN accelerator, the LHC. A crucial contribution of IFAE to ATLAS was the construction of a major part of ATLAS calorimeter system. The construction of one of the three cylinders of the iron-scintillator calorimeter (TileCal), altogether 64 modules each weighing 12 tons, was completed in Barcelona in the spring of 2002. Another important involvement of IFAE in ATLAS is the development of a very large computer farm and the associated codes to select the events that will be recorded for physics analysis. Other ATLAS activities are described below in this report.

ATLAS will start data taking in 2008. This long wait, plus the fact that one of the main IFAE tasks, TileCal construction, had been completed, prompted the IFAE group to join the CDF collaboration, which has been taking data on the Tevatron at Fermi National Accelerator Laboratory since the '80s. The Tevatron produces the highest-energy collisions achieved to-date – 2 TeV in the *c.m.s.* of the colliding proton and antiproton beams – and will be in this position until the LHC achieves proton-proton collisions at a an energy seven times higher.

Starting on a different Particle Physics front, an IFAE group joined in 2002 a neutrino oscillations experiment, K2K, taking place in

Japan. K2K was initiated by the SuperKamiokande collaboration with the aim of verifying, in a controlled experiment, their 1998 discovery of neutrino oscillations. IFAE, together, with four more European groups, joined the collaboration for a second phase, which started in January of 2003 and was completed in November of 2004. Also in 2004 the IFAE, this time with more than 10 European groups, joined a more advanced neutrino experiment, T2K, which has been approved by the Japanese authorities. The T2K beam will be at least 20 times more intense than that of K2K. The goal of the experiment is to measure a yet unknown important parameter of the oscillations.

The Institute is a major participant in the MAGIC Particle Astrophysics experiment. MAGIC is an atmospheric gamma-ray imaging telescope currently operating in the island of La Palma. It consists of a single, parabolic, segmented mirror structure, which focuses the Cherenkov light from the electromagnetic showers produced by gamma rays in the atmosphere, onto a camera located at the focal point. A major contribution of IFAE to this project was the construction of the camera. The design of the camera was completed in the fall of 2000 and its construction was finished in the summer of 2002. The Telescope was inaugurated in 2003, commissioned during 2004, and began its full program of observations in 2005.

In 2005 groups of IFAE, IEEC (Institut d'Estudis Espacials de Catalunya) and CIEMAT (Centro de Investigaciones Energéticas, Medioambientales y Tecnológicas) in Madrid joined the DES (Dark Energy Survey) Collaboration, formed by groups in the US and UK with the aim of surveying a large part (5000 deg<sup>2</sup>) of the sky in the Southern Hemisphere to characterize a very large sample of galaxies and galaxy clusters, with emphasis in cosmological studies. The survey will be conducted from a

4m telescope in Chile, for which DES is building a new, advanced pixel camera. The IFAE group is strongly involved in the design and fabrication of the electronics of this instrument.

An applied line of research on medical detectors, namely on the development of a digital detector of X-rays, had begun at IFAE, already in 1999. The detector is based on a dense semiconductor coupled to a pixelated chip, called Medipix-II, which had been developed by a collaboration with the same name, with IFAE participation. A four year project to develop the X-ray detector, named DEAR-MAMA, was approved by the European Union in 2001 and began in January of 2002. Two full prototypes have been built and the results are very promising. The DearMama project was extended until September of 2006, in order to perform thorough tests of the device. This project has generated a US patent and a spin-off company.

In High Energy Physics the need for remote handling of vast quantities of scientific data has received much attention over the last several years. This need is not restricted to the LHC experiments - facilities such as MAGIC as well as many others in other disciplines will also produce very large data samples that must be accessed by world-wide scientific communities. In 2003 three Spanish institutions, the UAB, the CIEMAT in Madrid and the Departament d'Universitats Recerca i Societat de la Informació (DURSI) of the Government of Catalonia, together with IFAE, jointly founded the Port of Scientific Information (PIC). This center aims at being a focal point of the global computing grid for scientific projects requiring the processing of large amounts of data. The PIC was chosen by the Spanish Ministry of Science and Education as a Tier-1 center for LHC computing. IFAE has been charged by the other partner institutions with the administration of PIC. The scientific activities of PIC are not described in this document – the reader is referred to the PIC reports.



## 7.1 ATLAS

CERN's Large Hadron Collider (LHC) will deliver the first proton-proton collisions in the near future, thereby opening a new energy frontier in which phenomena beyond the Standard Model of particle physics are expected to be discovered. The IFAE joined ATLAS, one of two international collaborations that propose to exploit the full potential for new discoveries of the LHC, already in the year 1992. The ATLAS detector is 22 meters high and 44 m long. It uses novel technologies such as the enormous toroidal superconducting magnet system or the central pixel detector, which consists of specially designed microchips with tens of millions of electronic channels.

To keep a general long-term perspective in the vast physics program of the LHC, the ATLAS IFAE group strongly contributes to a broad spectrum of topics that are critical to achieve optimum detector performance, namely and to the overall life of this large collaboration. Our contributions are along five lines: the Tile Calorimeter, the Trigger System, preparations for the LHC physics, preparations of the computing infrastructure, and participation in the management of ATLAS.

### **The ATLAS Tile Calorimeter:**

#### Construction in the IFAE of one of three "barrels" (700 tons) of the Tile Calorimeter

The serial production of modules began in the autumn of 1999 and concluded in May, 2002, exactly in due time. The module quality, controlled during the production, was well in line with the requirements of the hadronic calorimetry. All the 64 modules that have been built have been sent to CERN and pre-assembled on surface, in preparation for later assembly in the cavern of ATLAS. The pre-assembly of the calorimeter cylinder constructed at the IFAE, and later of the other two barrels, were done under the supervision of our mechanical engineer Lluís Miralles, Tilecal

Project Engineer at that time. The cylinders were then disassembled and reassembled inside the experimental cavern. The process started in 2005 and came to conclusion in February 2006.

#### Design and manufacturing of the calibration electronics for the whole TileCal

Calibration electronics is another major contribution of the IFAE group to TileCal. This system was designed to read either the PMT currents produced by the Cs<sup>137</sup> sources, or the "Minimum Bias" currents produced in ATLAS by low-transverse-momentum interactions. After ATLAS installation in the experimental cavern, and throughout the life of the experiment, Cs<sup>137</sup> sources will be inserted into the Tile calorimeter during periods without proton beams. This will allow to perform the initial inter-calibration of the entire calorimeter, and to maintain the calibration by monitoring changes in the response of any readout cell. On the other hand, monitoring Minimum Bias currents during data taking provides real-time information on calorimeter performance, and may even allow real-time relative instantaneous luminosity monitoring.

The front end of the source calibration electronics consists of about 10,000 amplifier channels (of which 11,000 – including spares – were built in 1999). In 2001, production of 270 analog-to-digital conversion (ADC) circuits took place; an additional 100 were added in 2004. The data acquisition interface between these circuits and the Detector Control System (DCS) is a VME/CANbus module known as Read Out Buffer (RB), designed and extensively tested at IFAE and in the test beam. The final batch of 20 RB boards was manufactured in 2004. The boards are now in use in Tilecal and play a crucial role in the on-going commissioning of Tilecal. Calibration and monitoring tasks in Tile Calorimeter are controlled by another board designed at IFAE. Six (6) such VME-based, ATLAS-Tile interface boards, called SHAFT, were produced



*A view of the ATLAS cavern in March 2006: The Tilecal Barrel built at IFAE (brown cylinder on the left) is being inserted into the huge toroidal magnet vacuum vessels, built by a company in Spain. Two of the vessels are visible on the right hand side of the figure (structures with brown stripes). The superconducting coils of the barrel toroidal magnet system are inside these vessels.*

by the IFAE in 2006. In October 2006, M. Volpi presented his Master Thesis: “Design, implementation and performance of the integrator based system for monitoring DC currents in the Tile calorimeter of the ATLAS experiment”.

#### Commissioning of the Tile Calorimeter in the Cavern.

The hadronic calorimeter of ATLAS, which is the very first ATLAS sub-detector deployed into the experimental cavern, has to be commissioned sharply in time, by the first LHC collisions. Our group is contributing several tasks to the calorimeter commissioning:

maintaining the front-end RO electronics, calibrating and monitoring the stability of the calorimeter response. Extensive quality control checks started in the second half of 2005 and continued throughout 2006. Being one of the expert groups of the Tile collaboration, the IFAE group provides major contribution to the commissioning of the complete Tile calorimeter read-out electronics chain. The IFAE group also strongly contributes to the program of inter-calibrating responses of the individual Tile cells by adjusting the PMT gains with the use of movable radioactive Cs source, which is another area of our expertise.

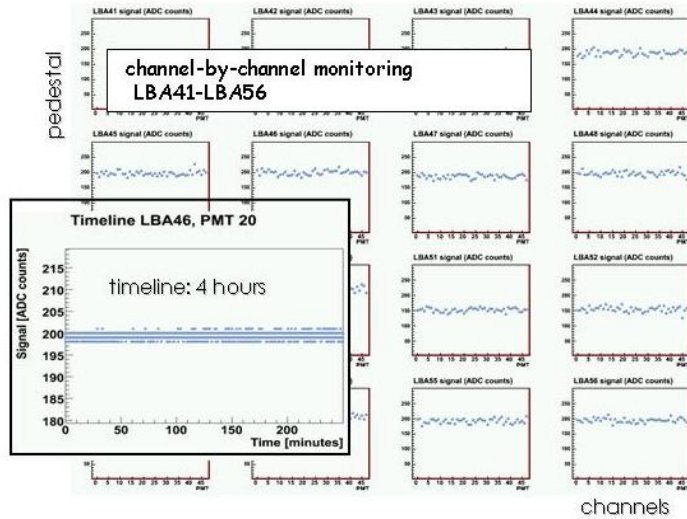

Top layer of the 6-layers SHAFT board, designed and built at IFAE (left); example of monitoring of the stability of the PMTs of one of Tilecal module.

In 2006, cosmic ray data have been regularly recorded, both in Standalone Tile Calorimeter mode and in combination with the Liquid Argon calorimeter or the Muon system. A detailed monitoring program has been developed by our group to run online during cosmic rays data taking. The monitoring is integrated in the Event Filter (EF), the Third Level Software Trigger, and provides data quality feed-back even before

data is stored on disk. The EF monitoring system receives as input a fully assembled physics event, performs a complete reconstruction of the event and monitors data quality and detector's correlation in the hypothesis of a cosmic muon event. The monitoring system also acts as server for the Atlas Event Display creating event data in the appropriate XML format.

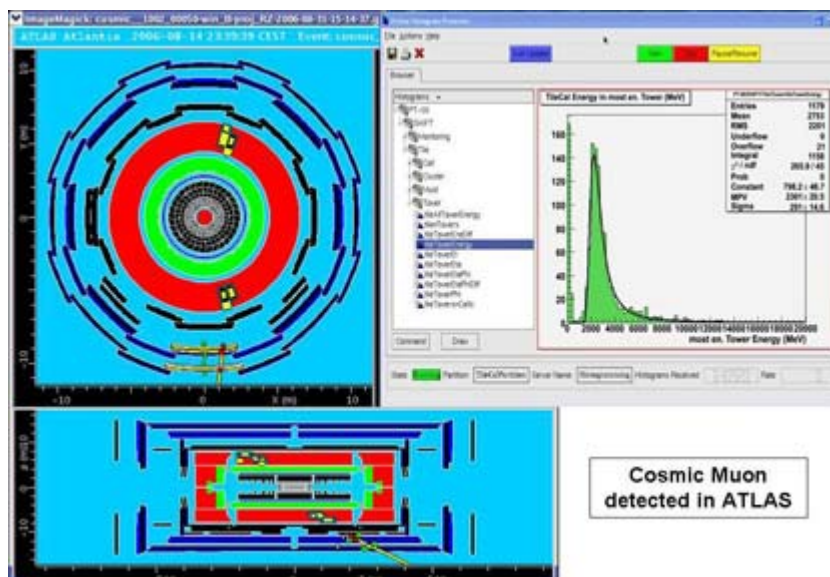

The ATLAS Event Display showing a cosmic ray going through the detector (left); Energy deposited by cosmic muons in the TileCal calorimeter (right)

## Contribution to the ATLAS Trigger system

Once the Tile calorimeter construction was well under way, the group reconsidered the best strategy to prepare for LHC Physics. It was natural to expand the contribution to software and physics analysis. The group decided to participate in the Third Level Software Trigger, the Event Filter, which uses many components of the offline event reconstruction and physics analysis. The Event Filter provides the final selection of physics events and streams them to the mass storage system, whose capacity requires the EF to reduce the event rate down to  $\sim 200$  Hz for events of size 1.5 MB. The Event Filter is software implemented in a computer farm of about 1000 processing nodes. Its architecture presents several interesting features, like access to fully assembled event data, plug-in type integration with offline event analysis algorithms, modularity and easily configurable choice of algorithms. Besides the main event triggering and data transportation functions, the Event Filter can also implement additional functionalities: monitoring of the selection process and of the detectors; data streaming for fast reconstruction of high-priority physics channels and on-line calibration. Hence it is an ideal place to get first-hand access and good understanding of the data. IFAE is one of the main contributors to the development of the Event Filter infrastructure. Since 2004, the group also actively contributes to the development of the Event Selection Software and related Physics studies in the framework of the ATLAS Physics Event Selection and Analysis (PESA) group. We share also the responsibility of the integration of all algorithms in the online environment and take active part in all the technical trigger preparation runs in the ATLAS online farms. The experience accumulated in that work will be directly useful for the physics analysis of the first ATLAS data and the searches for new physics.

## Event Filter

In the third level of the ATLAS trigger system, the flow of events and their processing are handled by two major software components, the “Event Filter Dataflow” and the “Processing Tasks” respectively, which run in every processing node of the farm. The IFAE is in charge of all software components related to the “Processing Task” (PT). The main role of the PT is to serve as interface and to execute the PESA software. However it can also be configured to run monitoring and/or detector calibration algorithms. Since 1999, various iterations in the design and implementation of the software took place. One of the main activities in 2006 has been the implementation of the calibration and monitoring functionalities in the System. Separate Processing Tasks dedicated to monitoring or calibration will run in parallel with the ones dedicated to Event Selection. This new feature required the development of a more complex event routing and labeling and a new event format.

The final ATLAS Event Filter will run on a large farm of about one thousand processors. Running the EF System on such a scale introduces additional scale-specific performance and fault tolerance issues, which can be tested and investigated only on dedicated Large Scale Tests. They were performed in 2006 in the LxShare computer facility at CERN. The TDAQ & High Level Trigger (HLT, including the EF), were running on up to 450 processing nodes and various aspects of operation and performance on this scale were verified. The main focus of the test was put on general stability of operations, as well as on the performance of database access with the implementation of database “Proxies” to avoid bottlenecks generated by multiple connections. The EF System was tested on various scales up to 15 SubFarm of 30 nodes, with 1 EFD and 2 PT components on each node. Performances using “Proxies” were compared to direct connections to the database.

A new TDAQ official package, “Sysadmin Tools”, has been developed by IFAE. It aims at providing an efficient and centralized way of performing administrative tasks on large farms like monitoring Unix processes, checking disk space, cleaning up after runs, etc. It has already been used by many testers during integration and commissioning runs. And it will play a more important role as the system scales up to its final size. Many large farms have become available recently as part of computing grids.

They potentially provide valuable resources for TDAQ testing. However the task of adapting the TDAQ to run on the Grid is not trivial, as the TDAQ system requires full access to the computing resources it runs on and real-time interaction. A scheme to resolve these issues has been developed at IFAE. It has been successfully tested in The Tier2 cluster in Manchester running a full TDAQ system on 400 nodes.

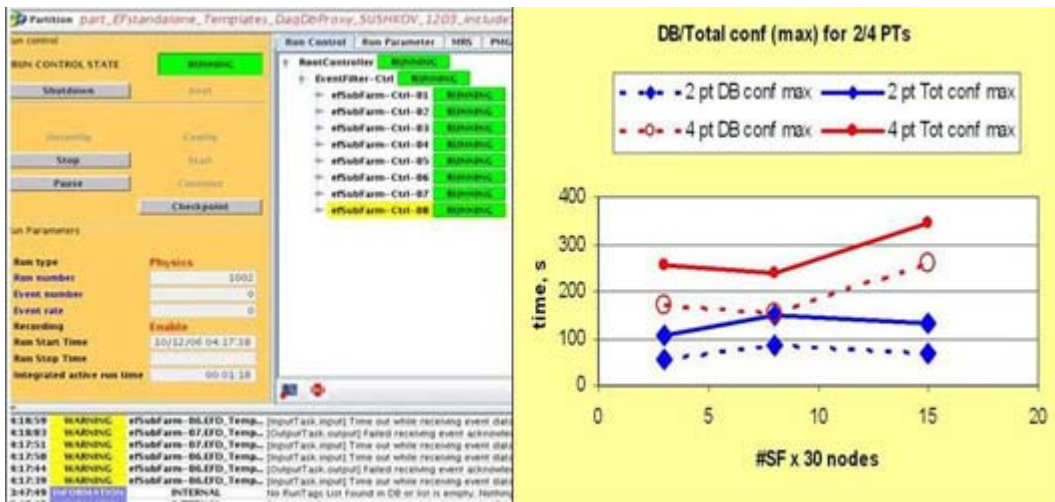

ATLAS DAQ User Interface (left) and example of scaling performance measurements carried out during the 2006 CERN LxShare test (right)

### Physics and Event selection Software and Analysis (PESA)

Since 2004, the group also actively contributes to the development of the PESA studies. The experience accumulated in this work will be directly applied to the physics analysis of the first ATLAS data and the searches for new physics. We are active developers of the Tau lepton trigger, the 3<sup>rd</sup> generation lepton and one of the favoured decay products of many predicted new particles. During 2006 the focus of the work has been the studies of the Level-1 and Level-2 Tau trigger performance. In addition, the overall coordination of the Tau Trigger work is under the responsibility of a member of our group.

The Level-1 trigger is hardware-implemented. We have studied the different menus that can be used at initial luminosity ( $10^{31} \text{ cm}^{-2}\text{s}^{-1}$ ) and determined the efficiencies of benchmark processes as a function of the PT and pseudorapidity of the generated Tau. The contributions from the different backgrounds have evaluated. Different ways to define the cluster of energy measured at Level-1 and various quantities available to characterize the clusters have been investigated. The Level-2 Tau trigger is software implemented. We maintain the software package for Tau calorimeter reconstruction. Recently the focus of the work has been more on performance studies. The execution time of the algorithm was evaluated. The time budget at the Level-2 is only of 20 ms. There is a trade-off between the

time it takes to access a large amount of data and the precision of the reconstruction. We chose the option giving reasonable physics performance within the online timing constraints. Concerning the physics performance of the algorithm, the different selection steps were optimized for a luminosity of  $10^{33} \text{ cm}^{-2}\text{s}^{-1}$  and were extrapolated for other cases. An important activity during this year has been the hadronic calorimeter calibration at

LVL2. Different schemes were considered and a simple approach was chosen as it provides the necessary performance. Tools to extract the calibration were developed and are being extensively used at the moment. The results of these contributions were presented in "Triggering on hadronic Taus: plans & performance studies in ATLAS/CMS", Charged H 2006, Uppsala University, Sweden, 13-16 September 2006.

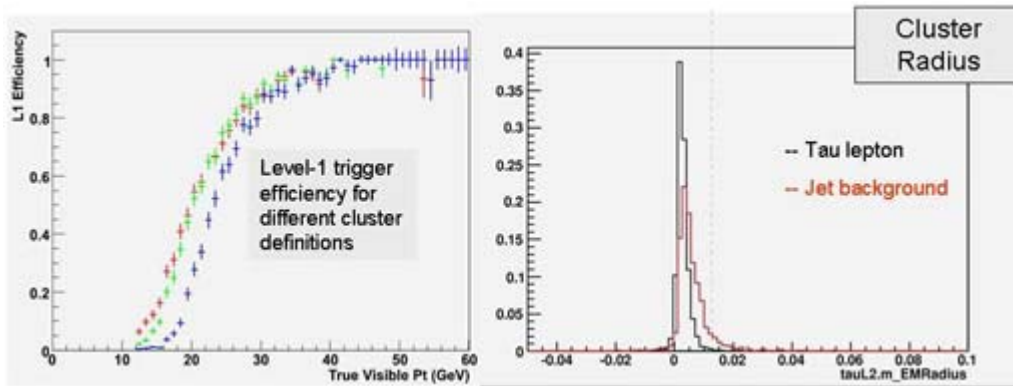

*Study of the efficiency of the Level-1 trigger for different cluster definitions (left) and example of separation power between the Tau lepton and the background from jets from one of the cluster shape variables at Level-2(right)*

### Integration

An important step towards getting the trigger software working online is its integration. This is done in two steps. First, the online conditions are emulated with software tools. The tool emulating the Event Filter has been the responsibility of IFAE since its design. Then, the Trigger software is run at the experiment in a subset of the future complete TDAQ System. Simulated data are used to feed the system. It is checked that trigger algorithms give identical results offline and online. Different trigger algorithms were tested independently and together, namely electron, tau, jet, muon and combined trigger algorithms. These week-long tests are carried out regularly. They are a responsibility of the ATLAS Online integration group for which a member of our group acts as co-convener.

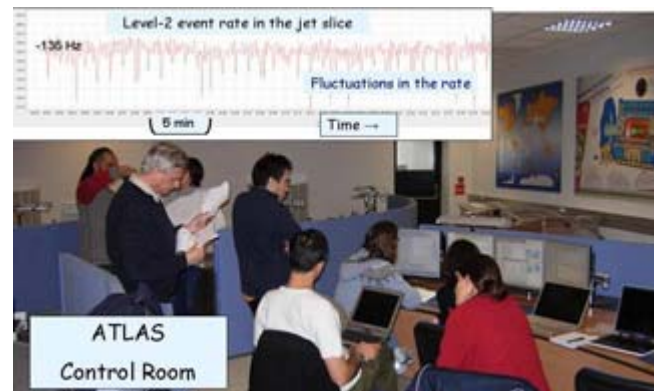

*The ATLAS control room during one of integration tests. The insert at the top shows a time chart of the level-2 rate using the combined trigger algorithms.*

## Preparation for LHC physics

The IFAE group has defined an initial physics research program at the LHC, designed to compete for an early discovery of new physics, considering a realistic evolution of machine luminosity and detector understanding. This choice is based on the knowledge accumulated during the ATLAS physics and detector performance studies carried out by the IFAE ATLAS group as well as on the experience and physics analyses performed by the IFAE CDF group at the Tevatron. One of the physics analyses that is carried out at IFAE since 2006 is the measurement of the differential cross section of Gauge bosons (W/Z) plus jets in the ATLAS experiment. The motivation is two-fold: the measurement of W/Z + jets is a fundamental benchmark for Standard Model physics at the LHC and it constrains one of the main backgrounds for the discovery of new physics

beyond the standard model, like SuperSymmetry or other models. The group is studying in parallel the processes with Z boson decaying to electrons or muons, for different jet multiplicities in the final state. The objective is to understand the acceptances, backgrounds and reconstruction efficiencies as a function of the jet multiplicity/kinematics. It is also important to examine the effects of the jet algorithms on the reconstructed jet properties and the jet energy calibration. This was the subject of the Master Thesis “ $\gamma$ + jet in-situ process for validation of the jet reconstruction with the ATLAS detector” presented by S. Jorgensen in October 2006. The predictions from different Monte Carlo generators (PYTHIA, ALPGEN) are being compared. They will be confronted to the data expected in 2008. ATLAS future analysis, exercised on large samples of recently simulated data, should be documented in detailed notes to be completed by spring 2007.

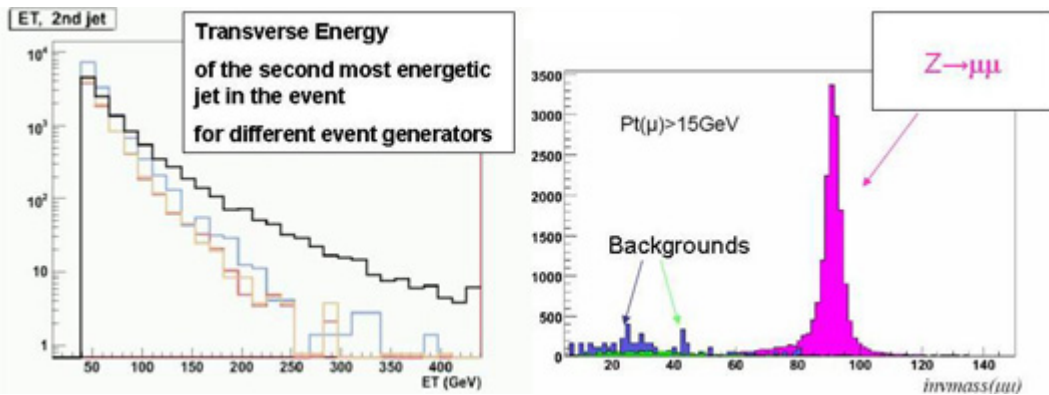

*Transverse energy distribution of the second most energetic jet in Z+ jets events as predicted by different generators (left); reconstructed Z( $\mu\mu$ ) decay and the expected background contribution (right).*

Top quark pair production is the other major Standard Model background to searches for SUSY at the LHC. Therefore, an excellent understanding of the properties of top quark pair production and their uncertainties is important. These properties should be extracted from the data and will be used to validate simulations. For the SUSY analyses with energetic jets, missing transverse energy and

zero, one, or two leptons, one defines  $t\bar{t}$ -like, SUSY-signal-free control samples, and uses them to extrapolate and estimate the  $t\bar{t}$  background in the signal region. In particular the decay  $t\bar{t} \rightarrow bW^+ b\bar{W}^- \rightarrow b(\tau\nu_\tau) b\bar{b}(q\bar{q})$ , where the  $\tau$  decays hadronically, contributes to the background to the no-lepton SUSY channel. This specific analysis requires the assessment of the  $\tau$  reconstruction and  $\tau$

trigger capabilities of ATLAS in an environment of multi jet background. We will profit from the experience in the reconstruction of  $\tau$ s obtained as active members of the Jet/Tau/Et miss Trigger group in the recent years.

### **Preparation of the computing infrastructure for the LHC, using the new GRID technology**

The processing and data storage requirements for LHC experiments have led the collaborations and the participating institutions to devote resources to the development of dedicated computing tools, based on the new, emerging technologies. The GRID is one of the technologies on which IFAE is basing its efforts to exploit LHC data. This technology is based on distributing computing and storage resources into several strongly connected centers, with the result that a user may be unaware of where his analysis codes are executed, or where the data he accesses are stored.

The IFAE-ATLAS group worked with GRID technology since the beginning, either directly in ATLAS or through European projects with IFAE participation: DATAGRID, CROSSGRID and EGEE. The GRID infrastructure of IFAE was started with ATLAS resources; this effort was followed with funding from an “Acción Especial” (FPA-2001-3969-E) followed by a three-year coordinated project of the principal Spanish HEP groups (FPA2002-04208-C07-04), coordinated by M. Delfino, currently the director of “Port d’Informació Científica” (PIC). Located on the UAB campus, very near IFAE, PIC has the goal of supporting science projects that require distributed access to enormous volumes of data, such as LHC experiments. The IFAE group has been actively participating in several PIC activities. One of those is LCG (for LHC GRID), realized by a collaboration of six Spanish groups coordinated by PIC. One of the LCG goals is the deployment of the GRID infrastructure of the LHC in Spain; this was successfully done in late 2003 and again in 2004. Another activity was taking part in a

simulation of LHC data analysis, specifically with ATLAS data. All Spanish groups take part in these simulations, known as Data Challenges. In general, the collaboration between PIC and IFAE is very productive for other aspects too, such as for instance tutoring students on the use of the GRID for their analyses. Another coordinated Project addresses preparations for ATLAS physics. The participants are the IFIC of Valencia, the UAM of Madrid and IFAE. The project is named “Development of the distributed TIER-2 infrastructure for the ATLAS experiment at the LHC (FPA2005-07688-C03-02). The TIER-2 will be devoted to the analysis of experimental data and to the generation of Monte Carlo events for ATLAS.

*The participation in all these technical tasks has a high formative value, particularly in complex data processing tasks, many of them in real time. The above mentioned experience is of great interest for the industry, since training in these topics cannot be easily given in universities or high schools.*

### **Participation in all the levels of the management of ATLAS**

Already since the first years of our participation in ATLAS the senior members of the group have been contributing to the management of the collaboration, to the decisions on technical relevant topics for the whole experiment, and to evaluation committees or dedicated task forces:

► M. Bosman: member of the Advisory group (2001-2003) and of several task forces, among which the chair of the ATLAS Radiation Task Force that undertook a five-year study of the radiation expected to be present at the interaction hall and thus at the ATLAS detector; coordination from 1994 to 2003 of the physics and detector performance study group “Jet- $E_T$ miss”; ATLAS Speakers committee, member July 2005 to June 2007 – to be chair July 2007-June 2008; coordination of the Jet/ $\tau$ /Etmis Trigger group; member of the ATLAS TDAQ Institute Board; HLT  $\tau$  Trigger coordinator.



► M. Cavalli-Sforza: president of TileCal Institute Board (2001-2003), president of Forward Review panel (physics measurements in the region of small angles (2001): possible extensions of ATLAS); national Spanish contact for topics of resources from 2000.

► I. Korolkov: member of the Tile Calorimeter Institute Board, TileCal representative to the ATLAS Luminosity Task Force. TileCal representative to the ATLAS SLHC upgrade task force, TileCal Speakers committee, member.

► I. Riu: co-convenor of the ATLAS TDAQ Online integration group

► Ll. Miralles: as project engineer of TileCal (2001-2004), in charge for the pre-assembly of three barrels of ATLAS.

► A. Pacheco, national Spanish contact for topics of computation until 2005.

► Georges Blanchot: presently at CERN in the capacity of Chief Engineer for the Electrical Cabling of ATLAS.

► The IFAE has also taken the responsibility of placing and following up on a contract between CERN and an industry in Spain that built the 8 very large vacuum vessels surrounding the superconducting coils of the ATLAS Barrel Toroidal Magnets. These vessels have been delivered to CERN and are at present being installed in the interaction point.

## 7.2 The Collider Detector at Fermilab (CDF)

In 2003, a group from IFAE joined CDF (Collider Detector at Fermilab) with full membership status. CDF is one of the two main collider experiments at the Tevatron at Fermilab, and it is being carried out by an

international collaboration of 800 physicists from 62 institutions in 12 countries.

At the Tevatron, proton-(anti)proton collisions are produced with a center-of-mass energy of 1.96 TeV. After the discovery of the top quark in 1995, the Tevatron has been upgraded: the center-of-mass energy has been increased (from 1.8 to 1.96 TeV) and its instantaneous luminosity has already achieved the Run II design value of  $2 \cdot 10^{32}/\text{cm}^2\text{s}$ . The Tevatron has already delivered a total integrated luminosity above  $2.5 \text{ fb}^{-1}$ . CDF has also gone through major upgrades. A new DAQ and trigger systems have been installed (where the latter includes an original setup which allows the detection online of secondary vertices), together with a new tracking chamber, new silicon tracker, a time-of-flight detector, new forward calorimeters and increased angular coverage for muon detection. All of this places CDF in a privileged position for studying fundamental particle interactions at the present energy frontier, a position that will be maintained until the startup of the Large Hadron Collider at CERN, foreseen for 2008. The work in CDF is quite complementary to the activities carried out within ATLAS. Given the magnitude and complexity of an experiment as ATLAS, and the intrinsic difficulty of the analysis of hadronic collisions, at the time of LHC and ATLAS startup, the experience gained in CDF will be invaluable – both for data-taking and data analysis and for the operation of the detector. This was in fact one of the reasons for joining CDF. CDF itself has a very rich physics program, as shown by the number of articles published using Run II data.



*CDF during the installation of the Silicon Detector into the tracking chamber.*

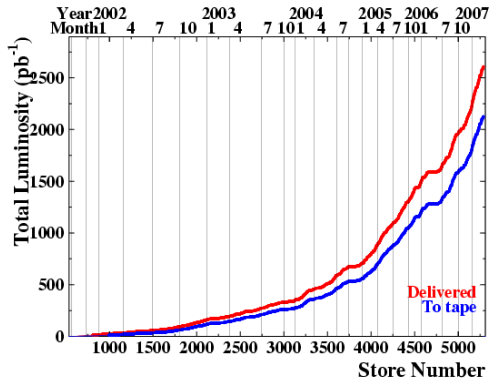

Total delivered and on-tape luminosity (updated: March 2007).

The experiment has already collected about 2000 pb<sup>-1</sup> (about twenty times more luminosity than that integrated in Run I) and it is expected to collect at least 4 fb<sup>-1</sup> before the LHC produces data in 2008. The following items summarize some of the most relevant aspects of the CDF physics program:

- Study of the physics of the top quark. This includes measurements of the production cross section, mass and couplings, among others.
- Study of the physics of the bottom quark and its bound states, including the recent discovery of B<sub>s</sub> oscillations and mixing.
- Precise measurements on the electro-weak sector like, for example, the mass and width of the W boson and measurements of the triple-bosonic coupling (WWγ), among others.
- Search for new particles and fundamental interactions (the Higgs boson, supersymmetry, extra-dimensions, quark-substructure, etc.).
- Studies on jet production and QCD processes at high and low transverse momentum, in addition to studies on the production of electro-weak bosons in association with jets in the final state, as main background for the Higgs signal and searches for new physics.

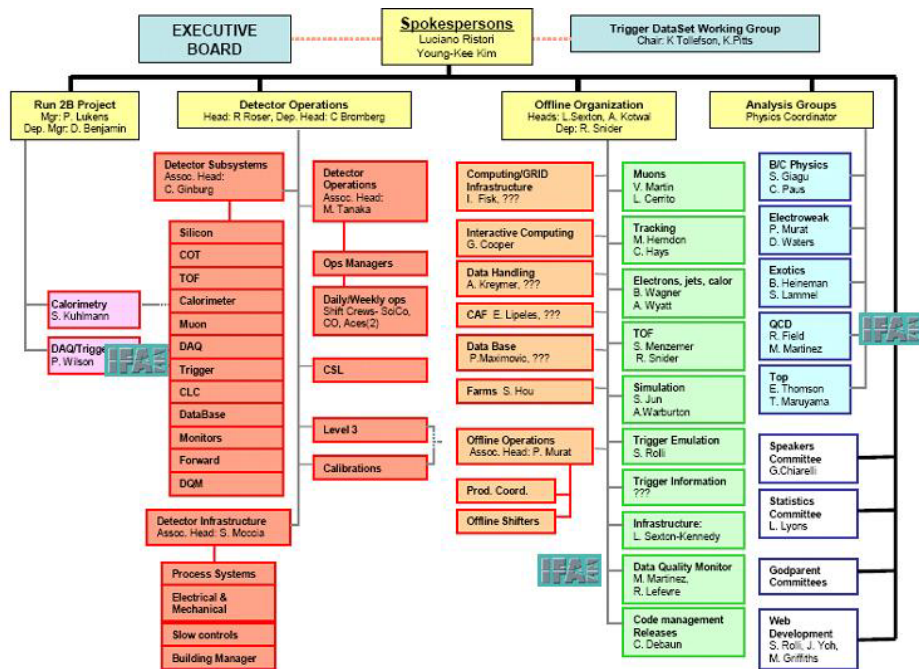

CDF Organization Chart (2004). The IFAE logo indicates those positions where IFAE maintains responsibilities before the Collaboration.

## **DQM: data quality monitoring of the CDF data**

The IFAE group in CDF has major responsibilities on quality monitoring (DQM) of the data used by CDF for physics analyses. The approval of our group's proposal by the collaboration back on May 2003 (notable because the experiment was already taking data after spending several years in the upgrade of the detector) showed the importance of the project.

The quality control is performed at two levels. Online, an automatic system alerts the CDF shift crew if faults are observed in the data. The online system is based on JAVA monitors that control the basic performance of the detector. The online diagnosis is available via Web and finally kept in ORACLE databases. Offline, after the data has been processed, a DQM system automatically checks the quality of the data using very high level physics objects (electrons, photons, muons, J/Psi, jets, etc) which, in addition to confirming the online diagnosis, detects possible errors introduced in the offline reconstruction codes or calibration constants. The final DQM decisions are employed to establish standard «good run» lists for the whole collaboration.

The DQM project requires a good knowledge of CDF, both of the hardware of the different detectors and of the offline reconstruction software. Moreover, the DQM activities involve a rather high level of leadership and coordination within CDF, which put IFAE members in a very visible position inside the collaboration. As it is shown in the Figure above, the DQM is considered in the CDF organization chart as one main «detector subsystems» and two IFAE members act as coordinators of the offline data validation activities.

## **Physics program of the IFAE group in CDF**

In addition to the work related to DQM, IFAE members at CDF continue the different activities defined in the IFAE physics program. The strength of the group on the physics analysis front can be inferred from the number of talks given in conferences during 2006:

- 1 plenary talk at XX Rencontres de Physique de la Vallée d'Aoste (La Thuile)
- 1 talk at DIS06 (Tsukuba, Japan)
- 1 plenary talk at HCP06 (Duke University, USA)
- 1 talk at SUSY06 (Irvine, USA)
- 1 plenary talk at QCD06 (Montpellier, France)
- 1 plenary talk at PIC06 (Buzios, Brazil)
- 7 talks at CDF Collaboration Meetings (Fermilab and Pisa)
- 2 talk at APS Conference (Dallas, Texas, USA)

and by the fact that Dr. Lefevre was appointed by the Collaboration as QCD convener for 2005-2007.

In 2003 and 2004, the IFAE group defined a research program based on the study of events with jets of hadrons in the final state, and multi-jet events with large missing transverse energy as a signature for new phenomena and supersymmetry. This physics program at CDF perfectly matches current activities of IFAE at ATLAS. This ensures a permanent coordination and the coherence of the efforts in both experiments, together with the best possible training for the future physics program at the LHC. Finally, the IFAE group at Fermilab heavily used the existing infrastructure of computing and data storage at PIC in order to consolidate a computer cluster dedicated to the physics analysis of the CDF data.

## Measurement of the inclusive jet cross section at CDF using the $k_T$ algorithm

In Run II, the measurement of the inclusive jet cross section is a fundamental piece of the Tevatron physics program. Thanks to the run II increase in the center-of-mass energy, the jet cross section is larger by a factor about 3 for jets with transverse energies above 500 GeV and the new measurements will extend the kinematic region of the transverse energy of the jets up to values of about 700 GeV (corresponding to distances of the order of  $10^{-19}$  m). The increase in the Tevatron luminosity will make possible to perform a precise jet measurement sensitive to the presence of new physics. The data will have the necessary statistical power to further constrain the gluon distribution within the proton at high- $x$  and provide a new measurement of the strong coupling constant  $\alpha_s(M_Z)$ .

The use of different algorithms to search for jets is also an important aspect of the QCD physics program in Run II. In Run I, CDF used an interactive cone-based algorithm in  $(\eta\phi)$  space to search for jets from the energy deposits in the calorimeter. During the past few years, theoretical developments have shown that such an algorithm is not suitable for fixed-order perturbative calculations since it is neither infrared-safe nor collinear-safe to all orders in perturbation theory. Moreover, additional «merging/splitting» parameters must be included that compromise the predictivity of the perturbative calculations at the parton level. Different improved algorithms have been discussed for Run II, however, only the  $k_T$  algorithm, which has been already used by the experiments at HERA and LEP, has all the desired theoretical properties.

The  $k_T$  algorithm allows a clean comparison with pQCD NLO predictions. Nevertheless, its performance in hadronic collisions will depend on a good understanding of the contributions coming from soft-gluon radiation and multiparton interactions in the final state. In

addition, Run II will explore the combination of calorimeter towers and tracks as input for the jet algorithm. These studies at the Tevatron will establish the future strategy for the jet physics at the LHC. This constitutes a fundamental aspect for the preparation of the IFAE group in view of the future physics program in ATLAS.

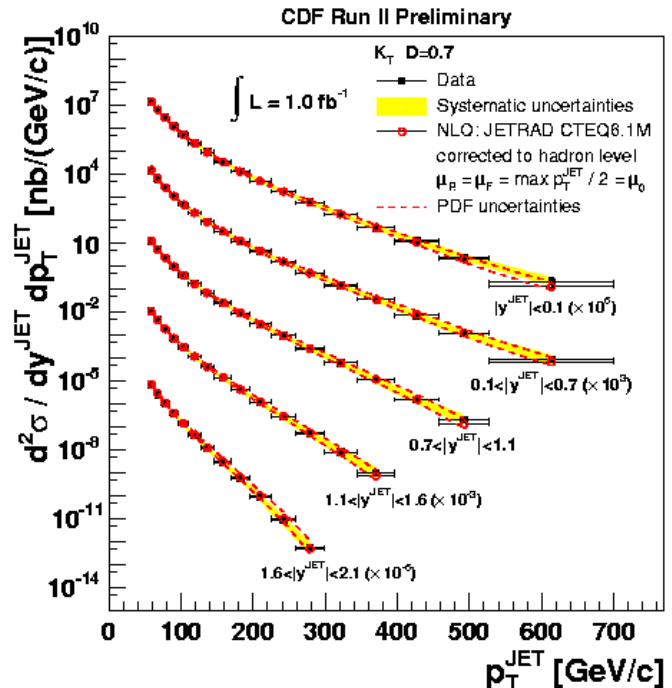

Measured inclusive jet cross section using the  $k_T$  algorithm.

The IFAE members have carried out the analyses using  $k_T$  jets at CDF. Final results, for central and forward jets, and using up to  $1\text{fb}^{-1}$  of Run II data, were presented during 2005 conferences (see summary Figure above). The measurements have been recently submitted to Physics Review D. A measurement for central jets was already published in Physical Review Letters. The results indicate a good agreement with NLO pQCD calculations and confirm the validity of the  $k_T$  algorithm to search for jets of hadrons in hadron-hadron environments. In the future, the IFAE team will focus in constraining the gluon PDF, as well as in the calculation of limits to the presence of quark compositeness, based on the measured cross sections.

## Search for Squarks, Gluinos and Extra-dimensions at CDF

The search for new physics beyond the standard model and, in particular, supersymmetry, is one of the main goals of both the Tevatron and the LHC physics programs. At the Tevatron, the best sensitivity to the production of supersymmetric particles comes from the study of hadronic final states with multiple jets and large missing transverse energy. These topologies could correspond to the production of squarks and gluinos which decay producing cascades of gluons and quarks, which are detected as multiple jets in the final state. For those models where R-parity is conserved, the LSPs (Lightest Supersymmetric Particles) are stable and leave CDF undetected, producing a signal of large missing transverse energy. The Run I results have established the best limits to squark and gluino masses within MSSM and mSUGRA models. The increase in the center-of-mass energy and luminosity in Run II will allow searching for supersymmetry in a new kinematical region with higher sensitivity at high masses. In case that no new physics is observed, the exclusion region in the squark-gluino mass plane will be significantly extended towards higher masses.

This analysis requires in-depth knowledge of the jets and missing transverse energy distributions, since the selection cuts must reduce the background by orders of magnitude. The background is dominated by QCD processes, W/Z production in association with jets, top production and beam-pipe interactions. In particular, Z+jets production processes where the boson decays in two neutrinos have a topology in the final state which is almost identical to that of supersymmetry. In order to avoid a posteriori biases in the measured distributions, the analysis will be carried out using «blind techniques», where a predefined signal region until all the elements of the analysis (selection criteria, background composition, systematic errors, etc..) are completely fixed.

First results have been obtained based on 371 pb<sup>-1</sup> of Run II data (see Figure below). The analysis was optimized in different regions in the gluino/squark mass plane. After selection cuts, no evidence of new physics is observed yet. The results extend Run I exclusion limits on squark and gluino masses significantly and have been presented at several international conferences. The analysis is now being extended to a 1 fb<sup>-1</sup> data sample and considering different jet multiplicities in the final state.

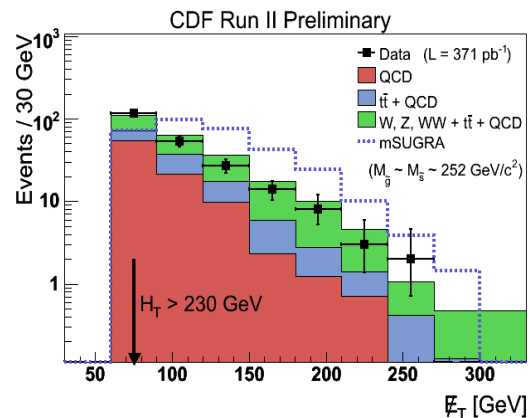
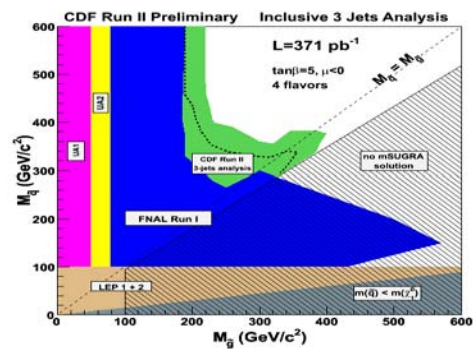

*CDF Run II results on the search for gluino/squark production based on 371 pb<sup>-1</sup>.*

## Study of Z+jets Final States

During 2005, the group opened a new line of analysis, defined by detailed studies of jet production in events with a Z boson in the final state. Precise measurements on Z+jets production constitutes a fundamental test of pQCD and provides a clean sample to validate

the Monte Carlo predictions for background estimations in searches for new physics. Preliminary studies, already presented in different conferences, indicate that a good understanding of the hadronic final state in Z+jets production has already been achieved in the current simulations of QCD production processes.

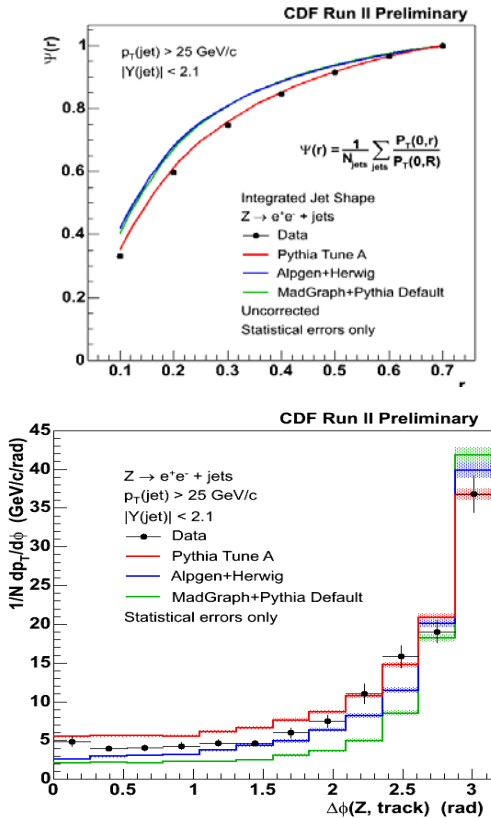

Measured Jet Shapes and Energy Flows in Z+jets Production.

### Consolidation of the cluster at Barcelona for the analysis of the CDF data

The IFAE physics program for Run II requires handling and analysis of large data volumes, in addition to the production of large Monte Carlo samples of simulated events necessary for the different studies. As an example, the measurement of the inclusive jet production mentioned above, assuming an integrated luminosity of about 1000 pb<sup>-1</sup>, have required the analysis of more than 20 TB of data, 6 TB of official Monte Carlo samples and the storage of

more than 4 TB of ROOT analysis Ntuples. As shown, an adequate CPU and storage capacity is fundamental in order to maintain the leadership in the different physics topics where IFAE is involved, and it must scale with the expected increase of the Tevatron luminosity in 2006-2008.

The IFAE group decided already in 2003 to use the PIC (Scientific Information Port) in Barcelona to install a computer cluster dedicated to the analysis of the CDF data. The infrastructure available at PIC, its personnel and technical support, as well as the CPU power and tape storage resources (a robotized system of 6000 tapes with an overall capacity of 1.2 PetaByte) is an excellent base to establish, with relatively low costs, a robust computer cluster devoted to the analysis of Tevatron data. In 2004, following the example from other CDF institutions, IFAE initiated the installation of a De-centralized CDF Analysis Facility (DCAF) at PIC and hired a software technician in order to maintain it. In 2005 and 2006 the computer cluster has been steadily increased and has already played a significant role in the generation of the necessary Monte Carlo samples for the physics analyses carried out at Barcelona. The CAF has been used by the rest of the Spanish community in CDF and recently it has been opened to general use for centralized Monte Carlo generation by the whole experiment. As can be read from the Figure below, during the last year 2006 the occupancy of the farm has been almost 100%.

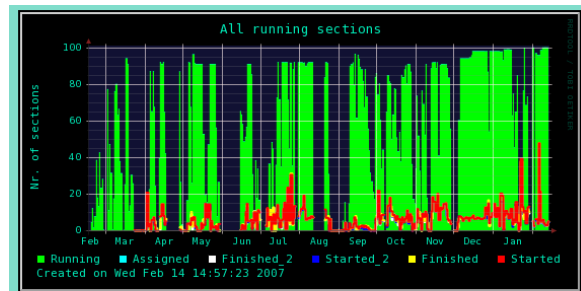

Usage of BCNCAF during the last 12 months.

During the next few years, the increase in the Tevatron instantaneous luminosity will produce a drastic increase of the physics data volume. The adequate increase of the CPU power and storage of the cluster in Barcelona will be one of the keys of the future success of the IFAE physics program at CDF.

### 7.3 The Neutrino Experiments at IFAE

The announcement of the discovery of neutrino oscillations in atmospheric neutrinos, made by the Super-Kamiokande collaboration in 1998, revived the interest in neutrino physics and in particular stimulated many new experiments which aim at elucidating the oscillation phenomenon. Super-Kamiokande also confirmed the "deficit" in the observation of solar neutrinos reported by many previous experiments. The final proof that this deficit is also due to neutrino oscillations was given by the SNO collaboration (with operates the detector of the same name, located in the Inco mine in Sudbury, Ontario, Canada) in 2002. These results imply that neutrinos have mass, albeit a very small one.

#### The K2K Experiment

The Super-Kamiokande collaboration (SK) also proposed a new parallel experiment, in which a beam of muon neutrinos is sent from the KEK Laboratory, where they are produced using a 12 GeV proton-synchrotron accelerator, to the SuperKamiokande detector, at a distance of 250 km.

K2K has a triple objective:

- To confirm the oscillation of muon neutrinos in a controlled experiment.
- To measure the oscillation parameters in a way independent of that of SK.
- To study in detail the difficulties and biases of a "long-baseline" experiment.

As explained below, the first two goals were fully achieved in 2005. The "long-baseline" technique is necessary for the study of neutrino oscillations as this phenomenon only takes place over long distances. Several experiments, now in preparation, are of this kind, and K2K is the first of them.

In K2K the beam of muon neutrinos (with a 98% purity) has an average energy of 1.3 GeV, and their spectrum extends up to 2.5 GeV. The neutrino interactions are measured in two detectors: a Near Detector (ND) located 300m downstream of the production point in KEK, and a far detector, Super-Kamiokande (SK). SuperKamiokande consists of a huge tank containing 50,000 tons of very pure water. Neutrino-muon interactions are detected and identified by the Čerenkov light generated by the muons produced in the interaction. This light is collected in the array of photomultipliers that cover the outer surface of the water tank. The near detector complex has several sub-detectors, among them a 1,000 ton water tank, using the same detection principle than SK, a series of water tanks (water target) interspersed with scintillating fibers (SciFi), a tracking calorimeter detector made of plastic scintillator bars (SciBar, see below) and a set of muon detectors.

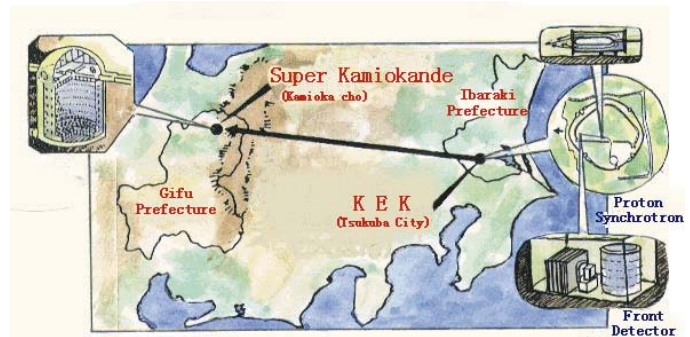

*Location of the different components of the K2K long base line experiment.*

The expected rate of interactions in SK is obtained from the extrapolation of the flux measured with the ND to the SK site. K2K is a "disappearance experiment" in that the oscillation is inferred by the observation in Super-Kamiokande of a number of interactions smaller than that expected from just a geometric extrapolation. From June of 1999 to February of 2004, the number of muon neutrino interactions observed in Super-Kamiokande was 107, whereas the expected number, in the absence of oscillation, was of 151(+12, -10) [ E.Aliu et al., Phys.Rev.Lett.94:081802,(2005)].

The probability that these numbers were observed in absence of oscillation is 0.005%. These results are compatible with expectations assuming the values of the oscillation parameters extracted by SuperKamiokande from the atmospheric neutrino results. The conclusion from Super-Kamiokande and K2K in what concerns oscillations, is that in the energy and distances relevant for the atmospheric and K2K neutrinos the oscillations are well described by a two-flavor oscillation  $\nu_\mu-\nu_\tau$ , giving information on the difference of two neutrino mass states, conventionally called 2 and 3, and a mixing angle, called also  $\theta_{23}$ . From K2K alone the data are compatible with  $\sin^2 2\theta_{23} = 1$ . The 90% contour lines cross the line  $\sin^2 2\theta_{23} = 1$  at  $\Delta M^2 = |m_3^2 - m_2^2| = 1.9 \times 10^{-3} \text{ eV}^2$  and  $3.6 \times 10^{-3} \text{ eV}^2$ .

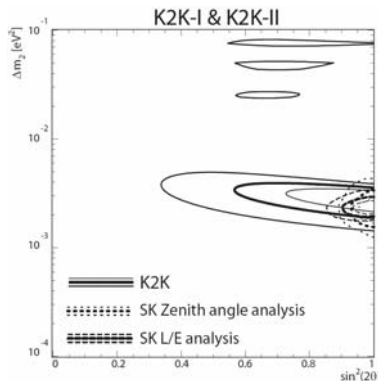

Allowed region of the oscillation parameters, and comparison with the values obtained by the Super-Kamiokande collaboration.

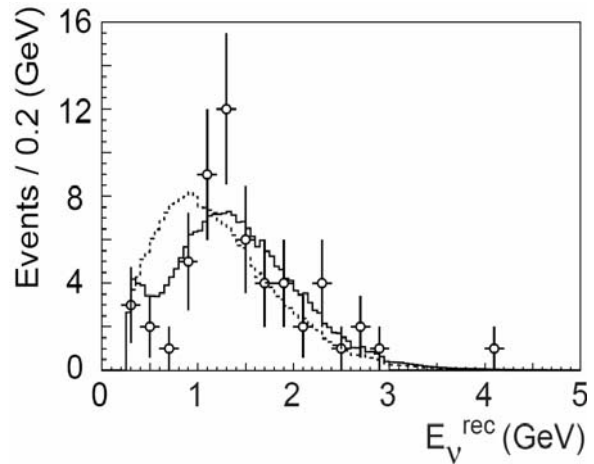

The K2K energy spectrum measured in SK for muon neutrino quasi-elastic events (data points). The curves, normalized to the number of observed events (107), show the expectations in the absence of oscillations (dashed curve) and with oscillations (solid curve).

IFAE, together with other four European groups, joined the collaboration in the fall of 2002 for this new phase of the experiment. The activity of the Barcelona group was centered on the ND, and in particular in a sub-detector named Sci-Bar, installed in the summer of 2003 (see Figure). The Sci-Bar is a fully active

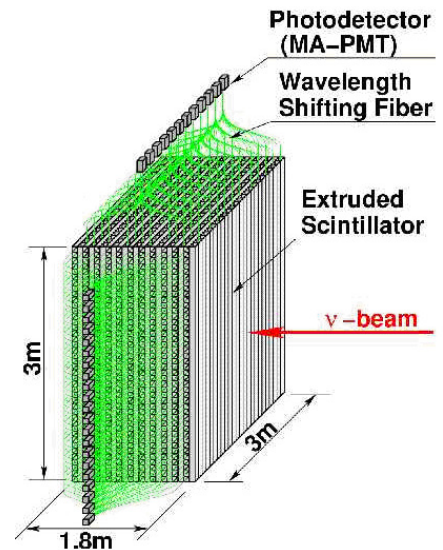

Sketch of the Sci-Bar detector.



calorimeter made of 128 planes of scintillating bars, with a total weight of 16 tons. Every bar is 3 m long and has a cross-section of  $2.5 \times 1.3 \text{ cm}^2$ . The orientation of the bars alternates from horizontal to vertical from one plane to the next. Each bar contains a scintillating fiber parallel to the 3m side. The fibers are read out by multi-anode PMT's in a total of about 15,000 channels. Sci-Bar detects protons produced in quasi elastic interactions,  $\nu_\mu n \rightarrow \mu^- p$ . Tracks need a minimum of 300 MeV/c to be detected.

The main tasks were:

1. The installation and commissioning of the detector. One of us (F. Sánchez) spent three months in Japan in the summer of 2003, as a Visiting Professor of the Institute of Cosmic Ray Research (ICRR) of the University of Tokyo.
2. The design and implementation of the main Sci-Bar track reconstruction program.
3. The design and implementation of several auxiliary reconstruction programs, such as alignment, calibration and others.
4. Several IFAE-centered analyses: measurement of the axial mass in the charged current quasi-elastic interaction (subject of a thesis defended in year 2006), measurement of the charged-current one pion cross-section (subject of another thesis), the charged-current coherent pion cross-section (subject of a diploma thesis) and the charged current multi-pion production (yet another thesis).
5. The coordination of the European activities. One of us (E. Fernández) is the European coordinator of the K2K collaboration and member of its Executive Committee.

The SciBar detector has demonstrated its potential for studying low-energy neutrino

interactions [see for example, M. Hasegawa et al. Phys.Rev.Lett.95:252301 (2005)]. The detector has been approved to run at the Mini-Boone neutrino line at Femilab, to study neutrino interactions below 1 GeV, (see SciBooNE Collaboration. FERMILAB-PROPOSAL-0954 and hep-ex/0601022). The project will begin at the end of 2006 with a small contribution from the IFAE neutrino group, that is in charge of the development of the software and reconstruction code.

### The T2K experiment.

As we just have seen atmospheric and K2K beam neutrinos give information on  $\theta_{23}$  and on the mass difference  $\Delta M^2 = |m_3^2 - m_2^2|$ . On the other hand solar neutrino results are consistent with the oscillation of electron-neutrinos into the other two species, and give information about the mass difference between the two mass states 1 and 2, and the mixing angle  $\theta_{12}$ . The states 1 and 2 are almost degenerate in mass,  $\Delta m^2 \sim 5 \times 10^{-5} \text{ eV}^2$  and  $\sin^2 2\theta_{12}$  is also close to maximum. But to complete the puzzle it is necessary to know the value of the other mixing angle,  $\theta_{13}$ , which is known to be small. The best option to measure this angle would be the observation of the transition of muon-neutrinos into electron-neutrinos. This is the principal aim of the T2K experiment, proposed by the SK and K2K collaborators together with other groups. A Letter of Intent (LOI) was submitted to the Japanese authorities, and the experiment was approved in 2004. The IFAE team signed the LOI (<http://neutrino.kek.jp/jhfnu/loi/loi.v2.030528.pdf>), together with other 12 European groups. The final proposal of the experiment was submitted in April of 2005. In T2K a beam of neutrinos, twenty times more intense than that of K2K, will be sent from Tokai, Japan, where the J-Park 50 GeV proton accelerator is being constructed, to SuperKamiokande, 300 Km away (see figure).



The T2K long-backline experiment.

The European groups contribute significantly to the Near Detector (ND) and in addition may contribute to some of the neutrino beam components. The ND will consist of a detector located a 280m from the proton target where the neutrinos are produced. In a later phase it is possible that a second detector will also be installed at 2 km. One of us (F. Sánchez) has been the European coordinator for the 280m detector from the beginning of 2004. The year 2005 has been used to define the baseline design of the near detector. This detector must measure the neutrino flux and study neutrino interactions from a beam with a spectrum similar to the one observed at Super-Kamiokande. The baseline design of T2K utilizes the UA1 magnet to provide a moderate magnetic field (0.2T). The detection devices are divided into two sections, one (called POD) dedicated to detecting neutral pions and another optimized to detecting and measure the momentum of charged tracks. The tracking section is composed of:

- two Fine Grained Detectors (FGD). This is a scintillator tracking detector similar to SciBar, serving as a neutrino target and proton detector
- three Time Projection Chambers (TPC) measuring the track momentum. The TPCs surround the FGD blocks to measure any charged track produced in the scintillators.

The Barcelona group in T2K focuses on the following lines of work:

1. Management: one of us (F. Sánchez) is part of the ND280 steering group.
2. Monte Carlo studies of the near detector for the conceptual design report.
3. Monte Carlo studies of the background on muons and neutrons in the experimental region of the detector. The expected neutrino flux is very high (170,000 neutrino interactions per ton and per year) and the superposition of events in the detector may limit its performance. This study is the subject of a Diploma Thesis.
4. Collaboration on the development of the reconstruction code for the ND280 detector with special emphasis on track reconstruction and fitting.

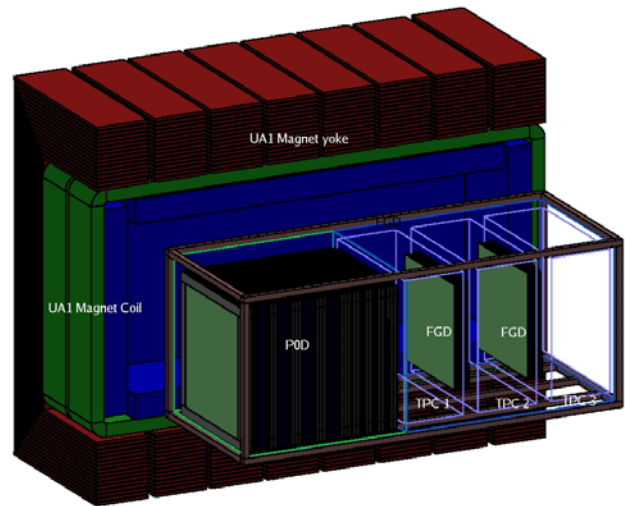

Sectional view of the ND280m detector, showing the components. The neutrino beam enters from the left.

5. Study of the feasibility of a gas TPC as the basic detector to measure the charge and momentum of the charged particles produced in the 280m detector. The group has initiated collaboration with Swiss, French, Italian and Canadian groups for the development of this technology. The charge readout being

considered consists of GEM or Micro-mega detectors, which simplify the read out and optimize the achievable resolution. The collaboration decided in spring 2006 to concentrate on MicroMegas, and this is the baseline design for the TPC readout system.

6. The IFAE neutrino group has also started the design of the control and monitoring system for the operation of the ND280 Magnet.

7. IFAE is also involved in the development, in collaboration with the University of Geneva, of the test bench where all MicroMega modules will be tested and calibrated before being installed in the final detector. The IFAE took the responsibility in the data acquisition and analysis tools, but it has also contributed to the design and commissioning of the gas system.

In the context of the TPC development, the group has been involved in the construction of a GEM prototype that is being operated at CERN inside the field cage of the experiment HARP. The prototype consists on two sectors readout by pad planes with a segmentation similar to the one proposed for the final detector ( $8 \times 8 \text{ mm}^2$ ). The detector has about 1200 readout channels and ran on cosmic rays from October 2005 until March 2006.

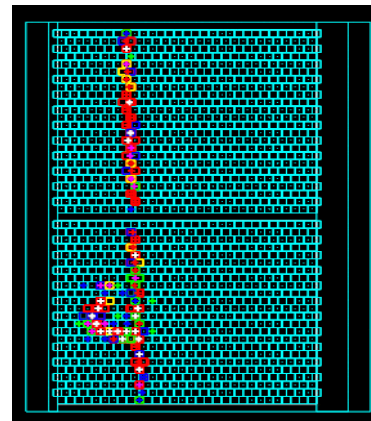
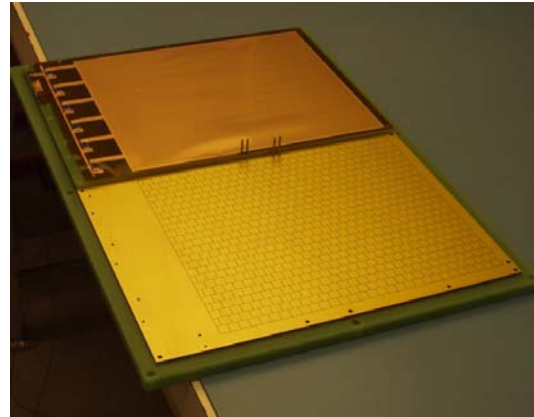

*(First) GEM layout where the pad plane and segmentation is shown (lower sector) and a GEM foil are shown (upper sector). (Second) Cosmic event in the TPC prototype at CERN is shown. The curling track is most probably a delta electron.*

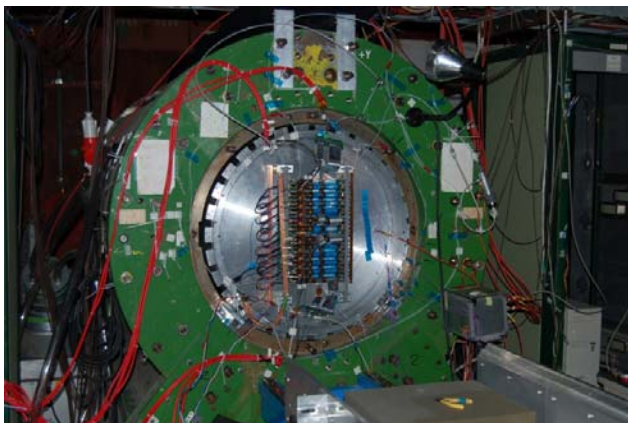

*Experimental setup at CERN showing the GEM prototype inside the magnet (green) and the HARP field change (aluminum).*

IFAE has contributed to the construction of an inverter board to allow the usage of ALICE readout electronics, to chambers operation, to data analysis and to the simulation of gas properties and electric field uniformity. It has also contributed to the analysis of the data to prove that the design is enough to reach the required performance at T2K.

It is expected that the first prototype of a full T2K TPC chamber (module 0) will be operated at the end of 2007. The full detector will be installed in April 2009, coinciding with the first neutrino beam.

## NEMO/SUPERNEMO

The recent construction of a new experimental hall in the Canfranc underground laboratory (LSC hereafter), near Jaca, opens up exciting opportunities for neutrino physics in Spain. This new hall, located at a depth of 2500m water equivalent (about the same depth as the Kamioka experiment in Japan) offers a surface, of about 600m<sup>2</sup>, sufficient to host one of the most exciting, next-generation  $\beta\beta 0\nu$  experiments, the Super Nemo detector.

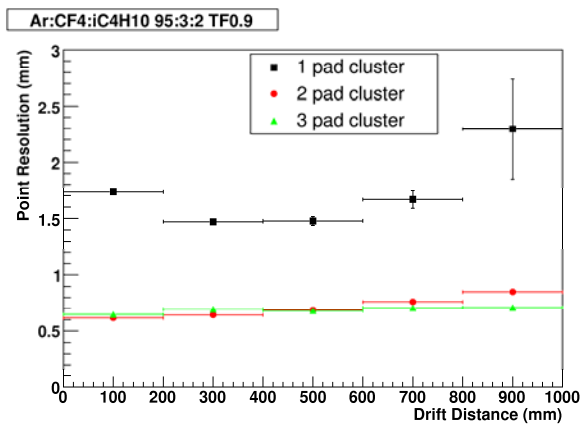

*Point resolution as a function of the drift distance obtained with the GEM TPC prototype at CERN using gas mixture Ar CF<sub>4</sub> IC<sub>4</sub>H<sub>10</sub> (95:3:2). The resolution is shown for three cases with 1, 2 and 3 pads per cluster. The requirement for T2K was a resolution better than 1mm at 1 m drift.*

Super Nemo would be the continuation of the NEMO experiment [1], currently taking data in the underground laboratory of the Frejus tunnel, near Modane, France. The experimental technique used by NEMO differs from conventional  $\beta\beta 0\nu$  experiments. Most of the current generation experiments are based on calorimetric detectors, where a double beta emitter crystal with very good calorimetric resolution such as Germanium (Ge) acts simultaneously as a source and as a detector. The advantage of such a technique is the very high energy resolution of Ge, which allows the observation of a narrow peak in the end-point distribution of the  $\beta\beta 2\nu$  spectrum. The

disadvantage is that the only signature available is the sum of the energies of the two electrons, and thus, one is sensitive to several chains of natural radioactive backgrounds resulting in photons and electrons, which can mimic the signal. A second disadvantage is that the experiment is limited to a single type of material, thus the sensitivity is limited by the uncertainties in the calculations of nuclear matrix elements for this specific material. On the contrary, the technique developed by the NEMO experiment consists in separating the source (which is inserted, as a very fine foil in the middle of the detector) from the detector itself, which is made of a tracking volume surrounded by a calorimeter. Thus, one measures the track and charge of the two electrons arising from the decay and their energy in the calorimeter. The advantage of the NEMO technique is that external backgrounds due to natural chains (such as the Bismuth-Polonium chain, which is a major background for Ge detectors) are very efficiently suppressed. In addition, one can use many different sources by “simply” changing the foil (in practice one divides the detector in many sectors each one with a different source if desired). The disadvantage of NEMO is that one cannot use crystals as calorimeter (due to cost and the low efficiency for 1 MeV electrons typical of the decay). The NEMO calorimeter, based on very pure scintillating bars, has a resolution of 10 %, much worse than the typical resolution of Ge.

NEMO operated with a mass of radioactive isotopes of 10 kg and solved several technical problems associated with this new technique for  $\beta\beta 0\nu$  searches, including the reduction of the background due to Radon, a natural contaminant of the air that limited the sensitivity during the first phase of the experiment. The initial publication on  $\beta\beta 0\nu$  search reports about 10 events at the end-point of the expected background of about 8 events due to Radon[2]. Currently, NEMO is taking data in a custom-made, Radon-free tent, where it will operate for at least five more years. The expected sensitivity

after this period will be competitive with Ge experiments, in particular with the Heidelberg-Moscow collaboration, which claims a signal of  $\beta\beta 0\nu$  in their data [3].

However, even if Nemo and other  $\beta\beta 0\nu$  experiments do not confirm the Heidelberg-Moscow claim, the uncertainties associated with nuclear matrix elements and the complicated analysis of the data related with a very weak signal amidst a large background, would be large. In order to definitively establish or reject this claim, and to explore a very sizeable fraction of the possible parameter space in neutrino masses, a number of next-generation  $\beta\beta 0\nu$  experiments are being proposed. In particular, the NEMO collaboration is proposing the construction of Super Nemo. With respect to NEMO, Super Nemo would have 10 times more mass (100 kg of radioactive isotopes) and would reduce the background by another factor of 10. This ambitious challenge requires the manufacturing of ultra-pure sources (possible with existing radio-chemical technology), the ability of measuring the activity of those sources to very low levels of background (to certify that they achieve the required purity) and several improvements in the detector design, in particular in calorimetry. Furthermore, to operate 100 kg of radioactive isotopes, Super Nemo needs a large surface, which is not currently available in Modane or Gran Sasso. This makes LSC the ideal host for this future experiment.

The IFAE neutrino group is collaborating with the IFIC in coding the simulation and reconstruction software, profiting from previous experiences in K2K and T2K. IFAE will be also involved in the physics studies to be performed with this code.

[1] R. Arnold *et al.*, "Technical design and performance of the NEMO 3 detector," Nucl. Instrum. Meth. A 536 (2005) 79

[2] R. Arnold *et al.*, Phys. Rev. Lett. 95 (2005) 182302

[3] H. V. Klapdor-Kleingrothaus, A. Dietz, H.L. Harney and I.V. Krivosheina, Mod. Phys. Lett. A 16 (2001) 2409.

## 7.4 The MAGIC Experiment

The MAGIC-IFAE group is one of founding members of the MAGIC collaboration. Since 1996 it participated in the R&D and the design study to define the technical characteristics and physical aims of the MAGIC telescope for gamma-ray astrophysics in the 50 GeV – 10 TeV energy band. IFAE was assigned the task to construct of the camera and its associated systems. Among others, the responsibilities that our group assumed in the construction of the first MAGIC telescope were the following:

- Design, construction and commissioning of the telescope camera.
- Design and implementation of the camera control system.
- Design and implementation of the Camera Monte Carlo simulation
- Design and implementation of the Central Control system
- Design, construction and commissioning of the calibration system.
- Design and construction of the Telescope Control House.

The construction of the MAGIC structure began in autumn 2001 and all the elements that allow the control of its movement were already operating in fall 2002. The group installed the camera of the telescope and all the control systems in summer 2002. The official inauguration of MAGIC took place in fall 2003.

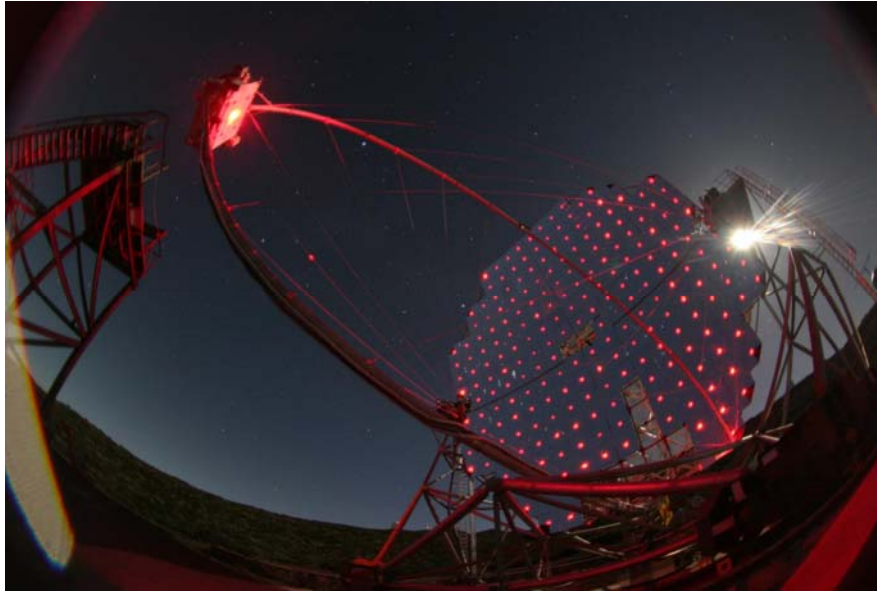

*A picture of the telescope during operation of its mirror focusing system based on reference laser beams.*

At present the second year of regular observations is almost complete. The IFAE group has focused its efforts on the analysis and physical interpretation of galactic sources and active galactic nuclei, and the application of the telescope data to Fundamental Physics studies. Fourteen papers of the MAGIC collaboration are already published or accepted for publication. IFAE has given crucial contributions to many of them. Four PhD theses have been completed at IFAE on the basis of first cycle data. Let us summarize some of the recent findings of the MAGIC telescope.

### **Galactic Sources**

MAGIC observed two sources detected by the HESS telescopes in the southern hemisphere, HESS J1813-178 and HESS J1834-087. The MAGIC observations, specifically its spectrum, help to ascertain the nature of HESS J1813, which has been claimed to be both a supernova remnant and a pulsar wind nebula. HESS J1834 is an interesting case of a supernova remnant which is interacting with a molecular cloud.

Our telescope has also observed the Galactic Centre and has measured a gamma-ray spectrum which can be described using a power law. This result has strong implications in fundamental physics since it is hardly compatible with emission from dark matter annihilation. The MAGIC results allow to set upper limits to the density of dark matter in the centre of our galaxy or in the dark matter candidate particle annihilation cross section.

MAGIC recently reported upper limits to the emission of PSR B1951, a pulsar that had been detected at lower energies by the EGRET gamma ray detector and whose emission has been predicted by several theories to extend to energies in excess of 50 GeV. A non detection by our telescope may be an indication that the so-called outer gap models cannot be applied to such pulsar.

Based on observations in 2005 and 2006 which had been co-proposed by members of IFAE, MAGIC detected variable emission from the X-ray binary system LS I +61 303. This detection possibly solves the mystery of the low energy

gamma-ray source 3EG J0241+61 which was known but remained unidentified since the eighties. In addition it is the first evidence of variable, possible periodic, emission from this

kind of objects and consequently sets a milestone in the study of such gamma-ray sources. This discovery gave rise to a publication in Science magazine.

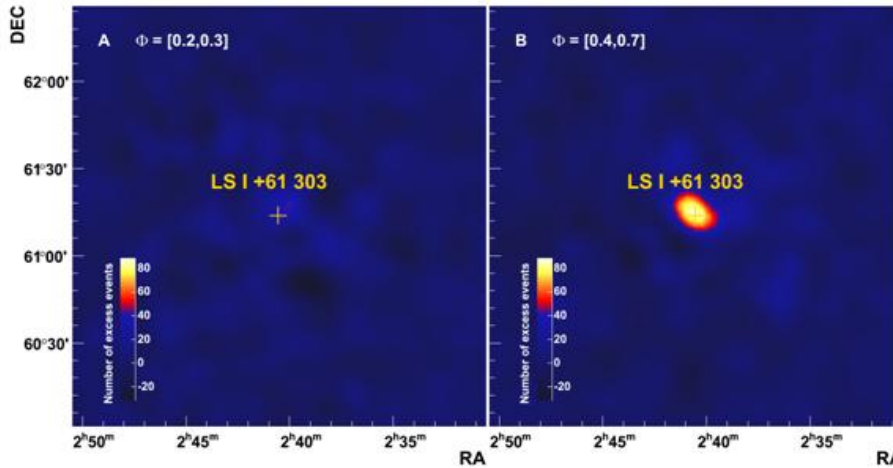

Two gamma ray images of the same field of view taken with the MAGIC telescope when the X-ray binary LSI + 61 303 was quiet (left panel) and when it was active (right).

### Active Galactic Nuclei

The telescope observed and detected numerous active galactic nuclei during the 2006 campaign:

- Mrk 421 is a well known gamma ray emitter. MAGIC followed strong day to day variations in its flux, ranging from 0.5 to 2 crabs. What came as a surprise was the fact that no intranight variability was observed, contrary to past observations in this energy range. It could well be that fast variability is only associated with higher states of emission, in excess of the registered 2 crabs.
- Mrk 501 was observed during a period of strong flaring in summer 2005. The subsequent analysis and very recent publication reveal extremely fast variability on the scale of a few minutes. This has strong implications in terms of the physics of the jet and can in addition be used to search for energy-dependent delays in the gamma-ray arrival times.
- Mrk 180 was in fact discovered by the MAGIC telescope and has turned out to be an AGN with a remarkably soft spectrum with a redshift of only 0.045. It shows no evidence for variability although it was observed during a reported optical flare.
- MAGIC has also detected emission from the AGNs 1ES2344 and 1ES1959. Both may be in quiescent state during these years after their detection back in the nineties at level of emission ranging from 10% to 100% of a crab.
- MAGIC has established the very high energy emission of PG1553 +113. This is an ultrasoft spectrum source whose redshift is unknown and may be as high as

0.5. Our telescope followed the object in 2005 and 2006 and registered a decrease in the flux of a factor of 3 in the second year of observations.

Gamma-rays from far AGNs are absorbed in the intergalactic background light. Measurements of their spectra thus allow to constrain and even measure the level of this light. Since this background light depends on the history of star formation in our universe, such measurements out to very far objects are instrumental in checking the consistency of galaxy formation theories. Once the intergalactic background field is measured, using independent instruments, the absorption of the gamma rays may allow a measurement of the distance to the AGNs which could be provide independent input to cosmological models.

### Gamma Ray Bursts

MAGIC was the first telescope to observe a gamma ray burst during its prompt emission (a few seconds after its detection at the X-ray satellite SWIFT) in the very high energy range. In fact the telescope measured during the time of two secondary peaks in the X-ray curve. This happened back in 2005 for GRB050713a. Subsequent analysis of these data revealed no significant gamma ray emission in the MAGIC energy range.

### MAGIC-II, A STEREOSCOPIC SYSTEM OF TWO TELESCOPES

To keep MAGIC competitive in this field in which there is fierce competition with other facilities, the collaboration decided in 2004 to start the construction of a second telescope which would fulfil three goals: (a) improve both, spectral and angular resolutions and background rejection, increasing the sensitivity by about a factor two; (b) hence effectively quadruple the observation time in the quest for new sources in the low gamma energy regime; (c) progress in R&D for even lower energy thresholds without interrupting the physics

observations by MAGIC, by providing a test bench for new developments. This is what the MAGIC collaboration has defined as its phase II.

IFAE has several goals within MAGIC-II:

1. Participate in the data-taking and analysis of astrophysical sources with the system of two telescopes.
2. Maintain and upgrade the equipment provided by IFAE for the first telescope
3. Design and construct a new ultra-fast and high-precision digitization and data acquisition system for the second telescope.

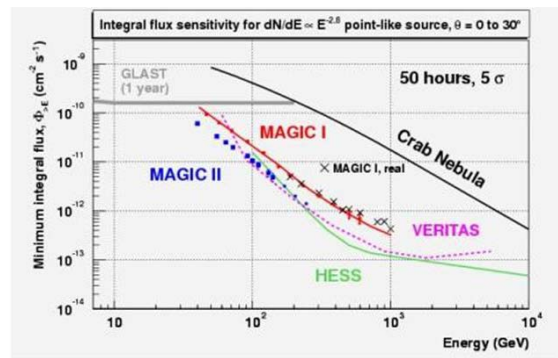

The sensitivity of MAGIC I for point-like sources, as obtained from Monte Carlo calculations, in function of energy. Black crosses are from MAGIC I observations. Curves for MAGIC II, HESS and Veritas are also given

4. Participate in the R&D for the high-quantum efficiency photosensors for the camera of the second telescope.
5. Together with the other Spanish groups, set up the MAGIC data centre at PIC in Barcelona.





*The two MAGIC telescopes in November 2006. The nearest instrument is MAGIC-II and is currently undergoing installation of its main components.*

The main components of the telescopes are currently under construction in the collaborating institutions. They will be delivered to La Palma at the end of 2007. The data centre for the second telescope was already set up in 2006 and underwent extensive tests with the data of the first telescope for most of the year. The readout of the telescope using the so-called DOMINO chip with a 2-4 GHz sampling rate began in 2006 and should be completed by the summer of 2007.

## **7.5 The DES (Dark Energy Survey) Project**

In 2005 a group at IFAE, along with groups of IEEC (Institut d'Estudis Espacials de Catalunya) and of CIEMAT (Centro de Investigaciones Energéticas, Medioambientales y Tecnológicas) of Madrid, joined the DES (Dark Energy Survey) collaboration. DES is formed by several institutes, from the United States and the United Kingdom, that work in the field of

Observational Cosmology. The aim of the project is to catalogue and to measure in four bands the spectrum of an enormous number of galaxies and clusters of galaxies (about 300 million) in a 5000 square degrees region of the Southern Hemisphere. A smaller region of the sky (of 40 square degrees) will also be repetitively observed, with the objective of discovering and measuring the photometric spectrum of about 1900 type Ia Supernovae, in a rank of red-shift  $0.3 < z < 0.75$ . These observations will permit the measurement of dark matter and dark energy densities and the dark matter equation of state through four independent methods: galaxy angular distribution, galaxy cluster abundance as a function of red-shift, weak lensing tomography and Supernova Ia luminosity distances versus red-shift. The galaxy cluster observations are done in conjunction with the South Pole Telescope (SPT), which observes and measures parameters of galaxy clusters through the Sunyaev-Zel'dovich effect. DES will provide the

red-shift of the clusters observed by the SPT in a  $4000 \text{ deg}^2$  overlapping region.

The DES Collaboration will construct an instrument consisting of a very large CCD camera of 2.5 aperture (DECam) giving images covering  $3 \text{ deg}^2$  of the sky. The camera, together with the optical correctors and the read-out electronics, forms a unit consisting of a cylinder about 3.5m long and 1.5m in diameter (see figure) which will be mounted at the primary focus of the 4m diameter Blanco Telescope, located in Cerro Tololo in Chile. In return the collaboration is granted 30% of all the observation time. This telescope belongs to the NOAO (National Optical Astronomy Observatory) institution of the United States, financed by the NSF (National Science Foundation). NOAO made an Announcement of Opportunities to equip the Blanco telescope with a new instrument in 2003, and DES was selected in 2004.

The three Spanish groups will contribute to the instrument and to the analysis of the data. Together they will build the electronics of DECam, as explained below, and they will contribute to the software and hardware of the telescope control system. The three groups are being financed by the Program of Astronomy and Astrophysics, which is part of the National Plan of I+D+i.

DECam consists on a mosaic of 62 CCDs ( $2\text{k}\times 4\text{k}$  pixels) together with 8 CCDs ( $2\text{k}\times 2\text{k}$ ) for focusing and alignment. Another 4 CCDs ( $2\text{k}\times 2\text{k}$ ) are used for guidance. The images have therefore 519 Mpixels. Each image, covering about 3 square degrees of the sky, will contain about 20 galaxy clusters and 200,000 galaxies; this entails an enormous data rate, of about 300 GB per night. The CCDs are of a new design, more efficient in the red and near-infrared regions of the spectrum than conventional CCDs.

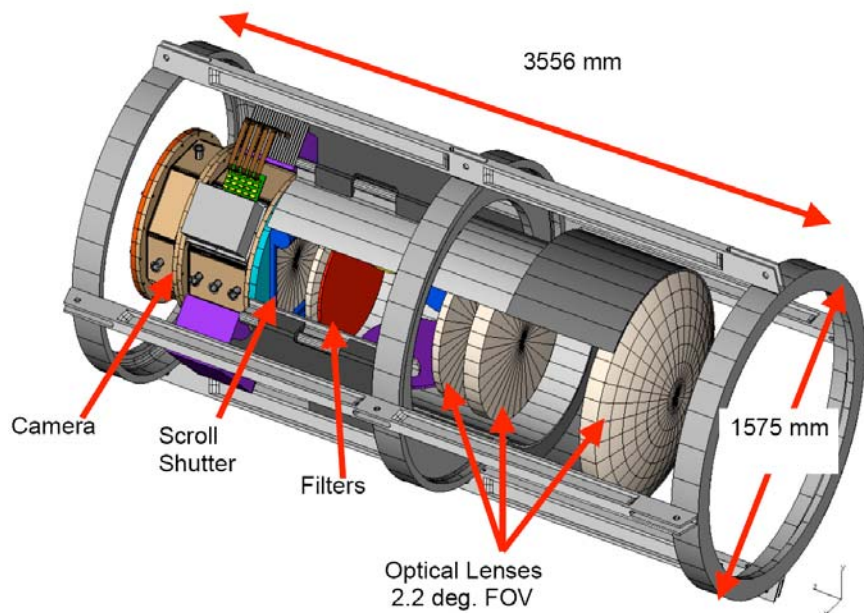

*A scheme of DECam, the camera that will be used in DES.*

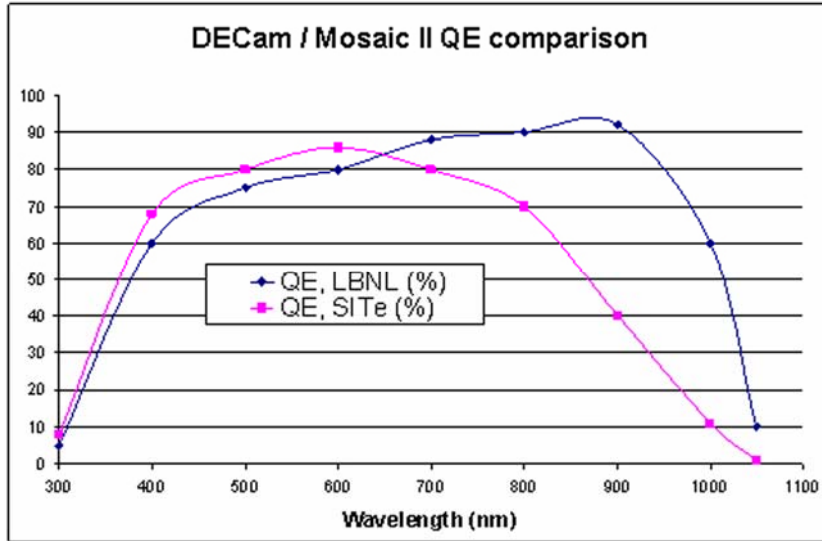

*The quantum efficiency of the DES CCDs as a function of the wavelength, compared with that of conventional CCDs.*

The CCDs are read out with an electronic system called Monsoon developed by NOAO for general use. The read-out is organized in 3 main cards. The DAQ card receives the signals from the CCD's. The Clock and Bias (CB) cards set bias voltages and send clock signals to the CCDs and the Master Control Boards (MCB; one for each electronics crate) read the information from the DAQ cards and transmit it to the DAQ computer. All these cards had to be designed, following Monsoon specifications, for the DES case. In the process some changes were made, in particular the number of channels per board was increased to fit the whole DES experiment into 6 crates of electronics. FNAL took the responsibility of designing the DAQ boards while CIEMAT did so for the CB boards and IFAE for the MCB. One important change was made in the system for transmitting the data from the MCB to the DAQ computer, which was changed from a proprietary system, called SYSTRAN, to an open system called Slink. The corresponding changes in the hardware and software were carried out at the IFAE. The final production of all the above boards will be done in Spain.

In order to check the electronics a whole set-up was put together in Barcelona. It consists of a cube at liquid nitrogen temperature and under vacuum to locate a test CCD, an optical bench to illuminate the CCD and a Monsoon crate with the electronics (see figure). This test bench is presently operative in Barcelona. The availability of this system is important for several reasons: first it allows the Spanish groups to test the electronics without having to travel to Fermilab. Second, since it is a complete system, it could be used in the future to characterize the CCDs to be used at the experiment. And, third, it allows the Spanish groups to acquire experience in the use of CCDs, which may be important for future experiments.



*A photograph of the test bench to test the DES electronics. To the left of the picture one can see the cube that contains the CCD together with a small liquid nitrogen Dewar, to maintain it cold. On the right there is an optical system to illuminate the CCDs. The electronics are inserted in a crate in the back of the picture (not seen).*

Another area of activity has been the preparation of the analysis of the data. Here the work of the IFAE group has concentrated on the use of Type Ia Supernovae in cosmology.

The DES collaboration has recently submitted a proposal to DOE and NSF, which is now being jointly reviewed by them. The science part of the proposal includes a long chapter on the use of Type Ia supernovas in DES as Dark Energy probes. One of us, Ramon Miquel, was among the main authors of that section of the report. In addition, a good part of the cosmological simulations of the report were carried out at IFAE.

During the plenary meeting of the DES collaboration that took place at the University of Chicago in December of 2006, R. Miquel was one of the organizers of the plenary session on Supernovae.

On the other hand, the group is also involved in the program of spectroscopic monitoring of the SNe found in the Sloan Digital Sky Survey-II project, in a range of red-shifts between 0.1 and 0.4. The group is participating in several applications for ESO telescopes time, and co-leads two more proposals, one for a Calar Alto telescopes and another for a telescope at the island of La Palma in the Canaries. This activity is of interest, both in itself and also as a preparation for the physics of DES.

## **7.6 The X-Ray projects**

2006 was the final year of the Dear-Mama project, which ended on September 30. From January to September 2006, major milestones were achieved. The Dear-Mama consortium decided to build a second X-ray machine dedicated to bone radiology (Dear-Mama-II) which can be seen in the figure. This X-ray machine is the first of its kind; it is as a

prototype based on a pixel CdTe detector coupled to photon-counting front end electronics (Medipix-II chip). It was commissioned and was ready and operational by March 2006; its first results can be seen in figure 2. When compared to another system, AGFA CR75.0, the Dear-Mama-II machine shows that it is superior in spatial resolution and in dose reduction, as shown in the next figures. In the first, one can see the image of a lamb cutlet and the corresponding contrast histogram. In the next one, the image of the phantom from both systems. One can judge, with the naked eye, which image has the best spatial resolution. In addition, the Dear-Mama-II image was taken with 6-times less radiation dose than that of Agfa-CR-75.0. We have also found that at 110keV, using a chest phantom, the efficiency of Dear-Mama-II machines is 11 times better than that of the Agfa CR75.0 in radiation dose reduction. Since the images of Dear-Mama-II machine are presented without contrast enhancement image processing, it is clear that there is still a good margin to reduce the radiation dose, while maintaining the same quality of the image, by a factor around 50. This is a very significant reduction in radiation dose especially when it comes to routine check-up such as chest radiology or men above 60 years old. These tests were carried out at UDIAT (Hospital Parc Taulí) with two teams; one from Hôpital d' Enfants Armand Trousseau led by Prof. J.P. Montagne, and the other is from Hospital of Vienna University led by Prof. F. Kainberger.

The Dear-Mama-I machine, dedicated to Mammography, was commissioned in summer 2005, and the clinical trials, using phantoms and specimens, were carried out during the 2006. The evaluation of Dear-Mama machine for Mammography was carried out by an expert team from Hospital Parc Taulí, led by MD. M. Sentis. It was done using phantom, and lumpectomy specimens. In the next figure, one can see a nurse fixing a lumpectomy specimen to the Dear-Mama-I detector using the compressing pad. The result can be seen in the

figure in which the micro calcifications are clearly visible. The conclusion is that Dear-Mama-I results, without the use of Contrast Enhancement Image processing, are comparable to the Selenia X-ray machine which is considered the best in the market. We have full confidence that there is ample room to improve the results of Dear-Mama-I machine this overtaking by-pass Selenia, both in spatial resolution and in image contrast. We expect accomplish this with X-ray Imatek SL, the spin-off described below.

**Patent:**

(WO/2003/019215) "METHOD AND DEVICE FOR THE PRODUCTION OF DIGITAL IMAGES" has been accepted in USA

**Spin-off:**

With the support and the encouragement of the Generalitat of Catalonia, through the Department Universities, Research and Information Society (DURSI), X-ray Imatek SL, a spin-off from the IFAE, was created in 2006. The goal is to exploit the Dear-Mama results and future X-ray projects. The aim of X-ray Imatek S.L. is to be a high-tech company that focuses on the developments and commercializing of digital X-ray sensors for general use with particular emphasis on medical systems. X-ray Imatek will be hosted in Parc Salut in Sabadell, with an initial surface of 600 m<sup>2</sup>. The first commercial products are expected in 2009.



*The Dear-Mama-II machine for Bone Radiology after being completed, installed, and ready to be used in UDIAT (Parc-Taulí Hospital).*



*A nurse in Hospital Parc Tauli (Sabadell-Barcelona) fixing a specimen to the detector of the Dear-Mama-I machine. In the background the Dear-Mama-II machine is partially visible.*

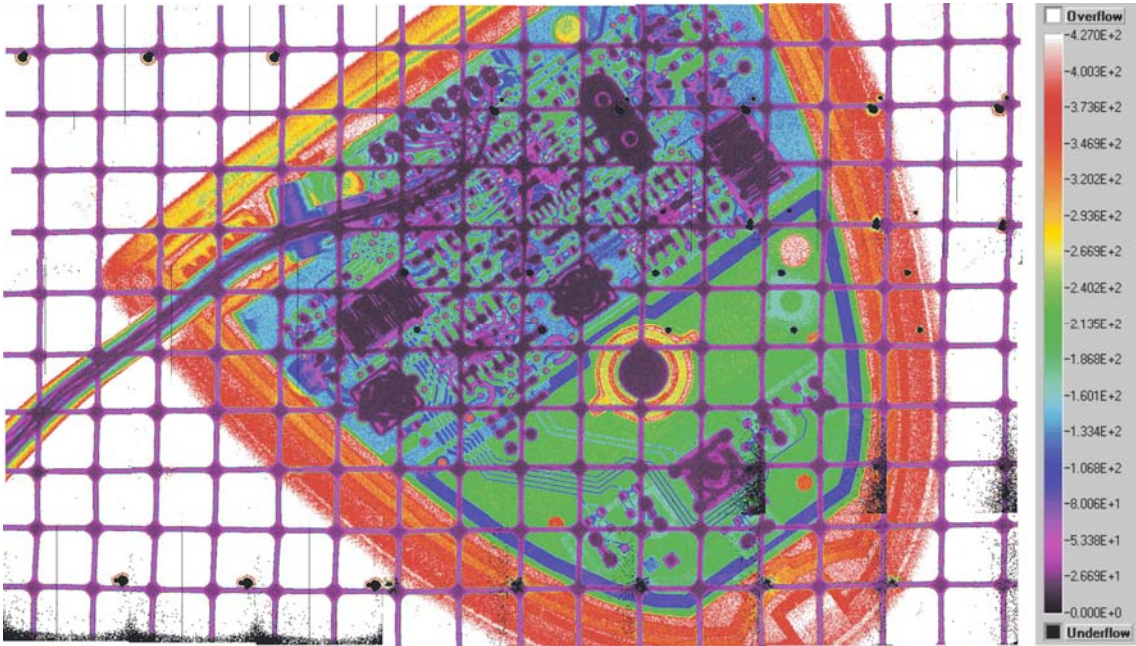

*Radiography of a computer mouse using 40kV and 2mAs dose. Even with this small dose, one can see the small details of the circuitry inside the mouse. Such device has great potential applications in security systems such the X-ray scanning machines in airports.*

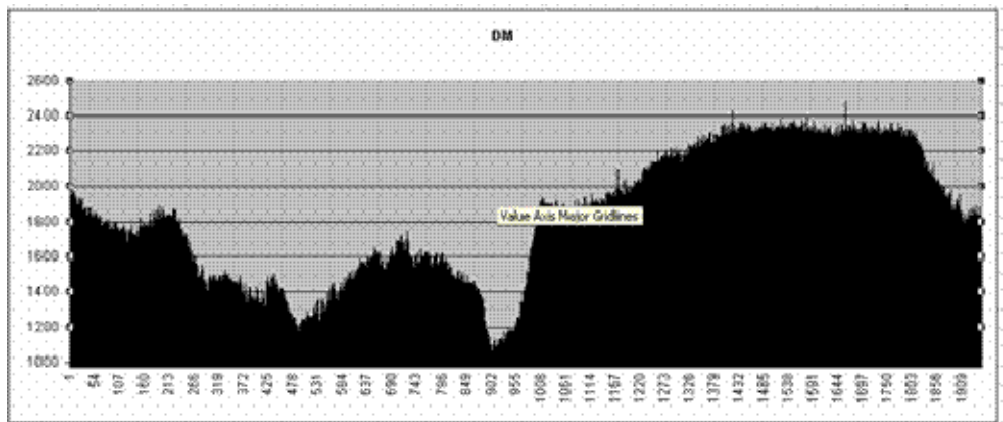
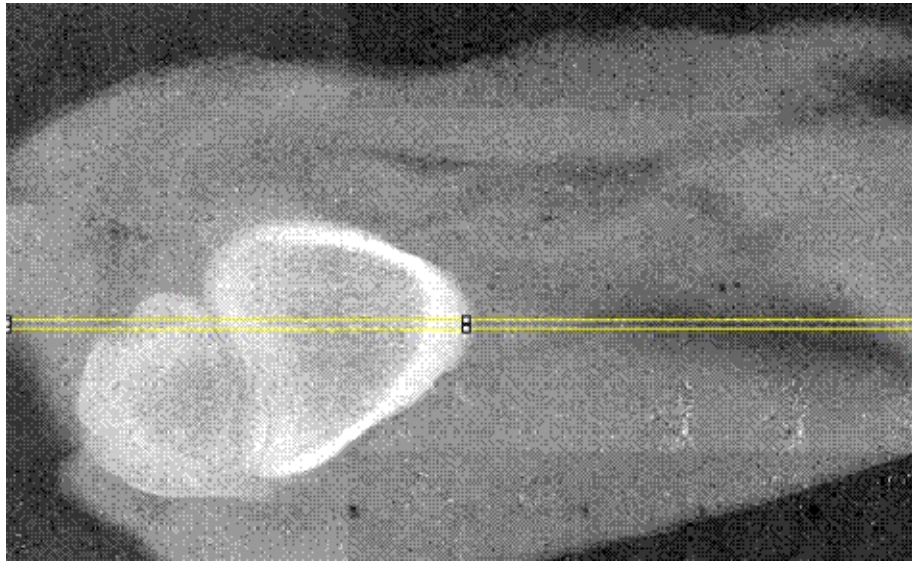

The image of the lamb cutlet taken by the Dear-Mama-II machine at 45kV, 4mAs using an additional Copper filter of 100  $\mu\text{m}$  thick. The cutlet is placed at 1 meter from the X-ray source and thus the corresponding radiation is 19.92  $\mu\text{Gy}$ . Below the image one can see the histogram that represent the profile of pixel counts in the area limited by the 2 yellow lines. The histogram reflects the density of the region. Low pixel counts indicate the presence of high density material, in this case the bone. The high counts indicate the presence of low density material, in this case the fat. The smallest count is about 1100 and highest count is 2300. The contrast between bone and fat using the Dear-Mama-II machine is  $(2300-1100)/\sqrt{(2300+1100)}=20.6$  for the above mentioned dose.

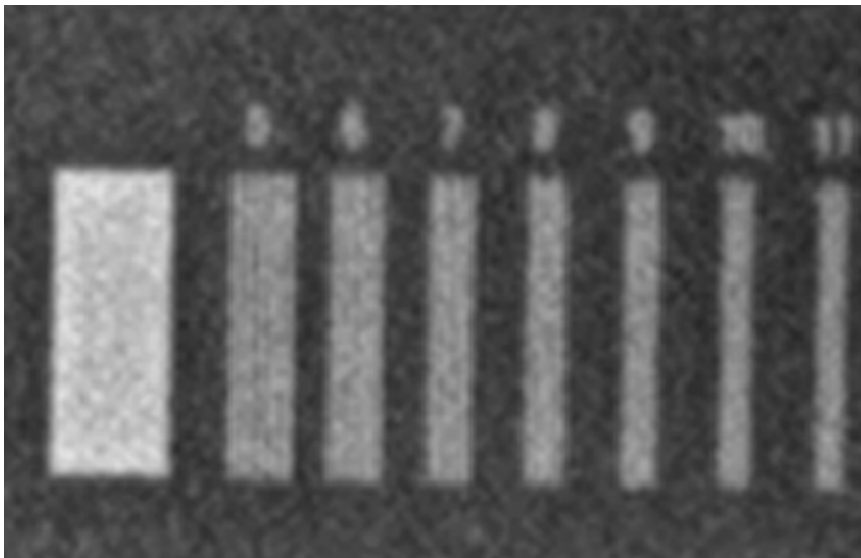
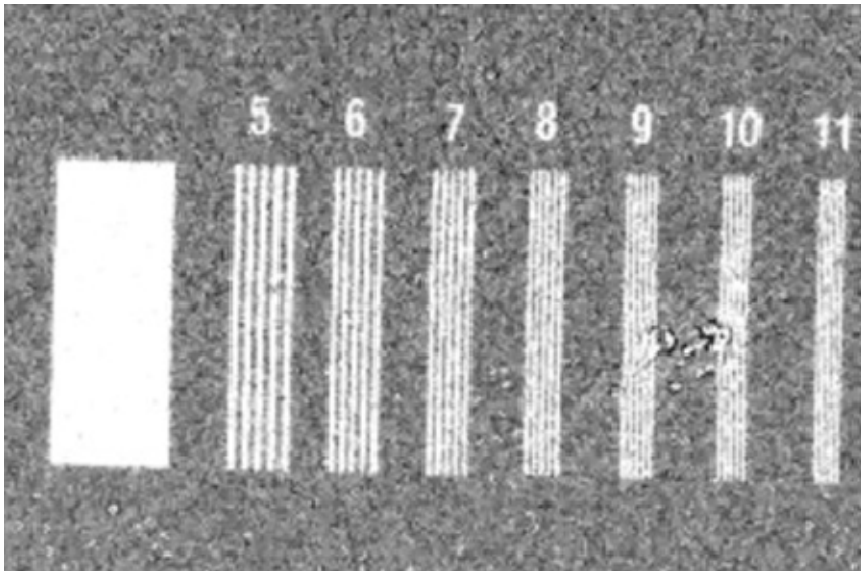

*First Image: radiography of a phantom with the Dear-Mama-II machine using a 40kV and 2mAs dose which corresponds to  $5.7\mu\text{Gy}$ . One can easily see the separation of 8 lines per mm.*

*Second Image: radiography of the same phantom with the AGFA CR 75.0 system using a 40kV and 5mAs dose which corresponds to  $35.7\mu\text{Gy}$ . One can hardly see any line at such a dose.*



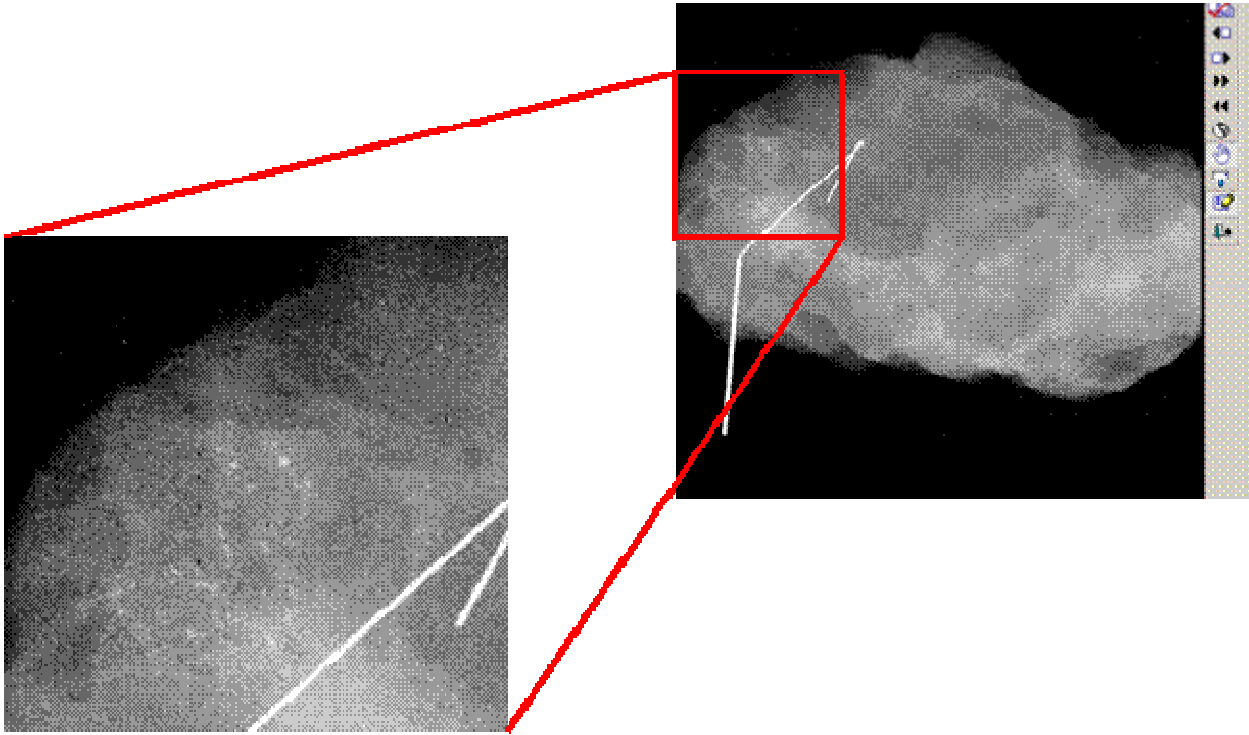

*Image of a lumpectomy specimen with micro calcifications located using a metallic guide wire. The Dear-Mama-I system lacks some contrast resolution due to the fact that the image is not processed with a contrast enhancement image processing algorithm. Nonetheless it is able to identify and display clusters of calcifications and all of the anatomic details of the specimen.*

## THE THEORY DIVISION

There are three main lines of research within the Theory Division:

### 7.7 QUANTUM INFORMATION THEORY

Quantum Information is a multidisciplinary research area where quantum physics meets fields as diverse as mathematical statistics, cryptography, computer science, and nanotechnology, among others. Quantum Information employs the laws of quantum mechanics, i.e. the laws of the microscopic world for the efficient processing of certain computational tasks that are intractable within classical physics and modern computers. There is a plethora of new possibilities beyond the classical world and many puzzling and counterintuitive effects. Quantum Information Theory is the theoretical body that extends classical information theory into this new framework.

The grounds for the spectacular development of Quantum Information Technology can be found in the seminal theoretical works concerning entanglement by A. Peres, the quantum cryptographic proposals of C. Bennett, G. Brassard and A. Ekert, the discovery of the quantum factorizing algorithm by P. Shor, and the quantum computer proposal by I. Cirac and P. Zoller. On the other hand, the impressive experimental advances in the fields of Atomic Physics and Quantum Optics have reached an unprecedented control in the preparation and manipulation of quantum systems. These recent advances are offering an extraordinary scenario for testing many predictions of quantum mechanics that had remained unchecked since the thirties. Most of the related theoretical work has been receiving renewed interest. The Quantum Information Group (GIQ) brings together researchers attached to the Autonomous University of Barcelona (UAB) whose work is mainly focused in the field of

quantum information and entanglement. GIQ is not an official entity but includes the whole membership of the QUIRT I & II (Quantum Information and Related Topics) projects financed by the Spanish Ministry of Science and Technology (MCyT) and the European Tematic Network QUPRODIS IST2002. The GIQ has the official title of "Consolidated Team", granted by the Generalitat de Catalunya, the Catalan local government, from whom it also receives financial support.

The GIQ research has become a reference in some of the topics developed by members of the team. The research of the GIQ has the highest visibility with many publications in the highest impact journals and contributions to congresses. The group has also established collaborations with leading international research groups, to mention a few: Garching (Prof. I. Cirac), Copenhagen (Prof. Polzik), Leiden (Prof. Gill), Sendai (Prof. Hayashi), New Mexico (Prof. Caves), Darmstadt (Prof. Birkel), Innsbruck (Prof. Briegel), etc.

The main research lines of the GIQ are: optimization of communication strategies and estimation of quantum operations taking into account realistic conditions for its physical implementation; classification and characterization of quantum tasks using systems of continuous variables; entangled pairs of particles: Bell inequalities, complementarity and quantum eraser; characterization of the dynamical properties of the entanglement in strongly correlated ultra-cold quantum gases and spin gases, and the design of photonic quantum gates for quantum computing.

## 7.8 ELEMENTARY PARTICLES IN ASTROPHYSICAL AND COSMOLOGICAL SETTINGS

The general goal of our project is the study of some of the theoretical issues in the physics of elementary particles and their interactions, particularly when we have an astrophysical or cosmological medium. In these media one has some processes that are suppressed in laboratory conditions, or at least they occur differently. Thus, the results that we obtain in our research complement and enrich the information obtained in laboratory experiments. In fact, the flux is in both ways; data from laboratory experiments can illuminate the physics of some of the aspects of star and universe evolution.

Our work is phenomenology-oriented and thus it is intimately linked to experiments, both laboratory type (high energy accelerators as LEP and LHC at CERN, low energy detectors, etc.) and observational (ground-based and satellite borne telescopes, etc).

It is worldwide recognized that our field, sometimes called either Astroparticles or Particle Cosmology, is in progressive expansion. One major discovery has been neutrino oscillations, detected from the analysis of atmospheric and solar neutrinos. This is very important for neutrino physics, to which we have been involved since many years and indeed it is an objective of our group. Other recent discoveries with impact in our field refer to the anisotropies of the microwave background, and the determinations of distances to supernovas. The emerging scenario from the analysis of all these observations is very interesting, and one is faced to deep questions. With our research we would like to contribute to these developments.

## 7.9 PHYSICS OF THE FUNDAMENTAL INTERACTIONS

Here we summarize and put in context the topics on which we are mainly interested.

There is a tremendous amount of experimental evidence that the Standard Model (SM) is fundamentally correct at the scales of energy and at the level of accuracy that we have explored so far. However, there are also many indications that the SM cannot be complete. For instance, we now have experimental evidence that neutrinos have a mass (although we do not know of what kind). Furthermore, we also know that the amount of particle-antiparticle asymmetry in the universe cannot be explained within the SM because it cannot produce enough CP violation. Finally, gravity still resists all attempts to quantize it as we have done with all the other fundamental interactions.

It may be that the key issue is the mechanism for mass generation in the SM through the Higgs field which, although being the one responsible for the largest amount of parameters in the theory, is the one least understood. It is intriguing that all the above questions may be linked, in a way or another, to the one piece of the SM for which there is still no direct experimental evidence: the Higgs particle.

Starting in 2008, the Large Hadron Collider (LHC) will search for the Higgs particle in the energy range where it is expected to be. If a particle is found at the LHC, we will have to make sure that it is precisely the Higgs particle of the SM or maybe something else. It is very important to study what this "something else" may be, i.e. what may be expected at the LHC. Be it Supersymmetry, Extra Dimensions or "Unparticle" Physics, it is important to know the main features of these scenarios to be able to recognize them. Even if a particle is found, it is important to analyze with the use of Precision Flavor Physics whether it is actually the SM Higgs or another particle, by a detailed study of high-precision observables such as, e.g., CP

asymmetries. This requires working in close collaboration with the experimental groups at ATLAS and LHCb.

However, the best experiments on CP violation are made with hadrons, which experience strong interactions at a scale at which perturbation theory is not applicable. At the phenomenological level, this of course requires a good control of this nonperturbative physics. At a more theoretical level, a deeper understanding of nonperturbative dynamics in Quantum Field Theory may also be very useful for an alternative mechanism of mass generation to the Higgs mechanism itself.

It is very likely that the new experiments at the LHC will reveal some of the answers to these questions. Therefore, in the light of these experiments, our group is devoted to study the physics at the electroweak scale, the origin of mass generation and important discrete symmetries, such as CP. In doing so, concepts such as Supersymmetry, Extra Dimensions or the recent "Unparticle" Physics, but also Precision Flavor Physics and Nonperturbative Strong Interactions play a major role. Finally, we believe that it is important to know about possible implications on particle physics models from cosmology and astrophysics which is also an interesting topic to which we direct our attention.