



Knock Down Locker Assembly Instructions

These Instructions Cover *Durable, Durable Plus* and *Competitive* Lockers.

CONTENTS:

General Instructions	1
Major Locker Components	2
Hardware and Small Locker Parts	3
Hook and Coat Rod Guidelines	4
Locker Latches	4
Multi-Tier Lockers	5
Zee Base	6
Individual Closed Bases	6
Individual Slope Tops, Slope Top Kits	7
Continuous Slope Hoods	7

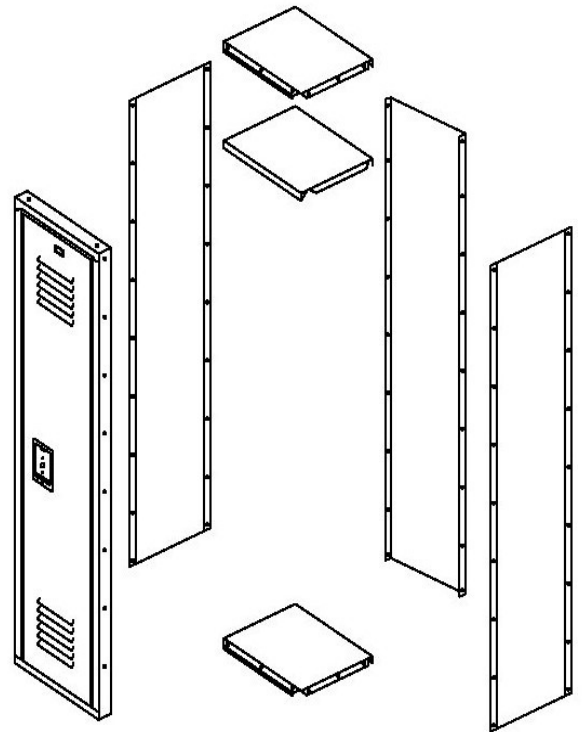

GENERAL INSTRUCTIONS

1. These instructions are for the person who will actually perform or supervise the assembly of the lockers.
2. Check material received against the packing list. First check the number of packages received and then check the contents of each package.
3. Check material for damage. If any of it is damaged, secure a “damage notation” from the carrier.
4. Identify each part as it is unpacked and put like parts together as close as possible to the working area in which they are to be assembled.
5. Be careful to use the correct hardware as specified in the assembly instructions.

CAUTION

It is the responsibility of the person’s assembling the lockers to properly install all components and hardware as specified in these instructions.

- INSTALL ALL UNITS PLUMB AND LEVEL
- TIGHTEN ALL HARDWARE SECURELY

WEC Manufacturing

P.O. Box 38190

• Germantown, TN 38183

Phone: (901) 367-3922

• Email: sales@itswec.com

www.itswec.com

Locker Tops, Bottom (T.A.B.) and Shelves

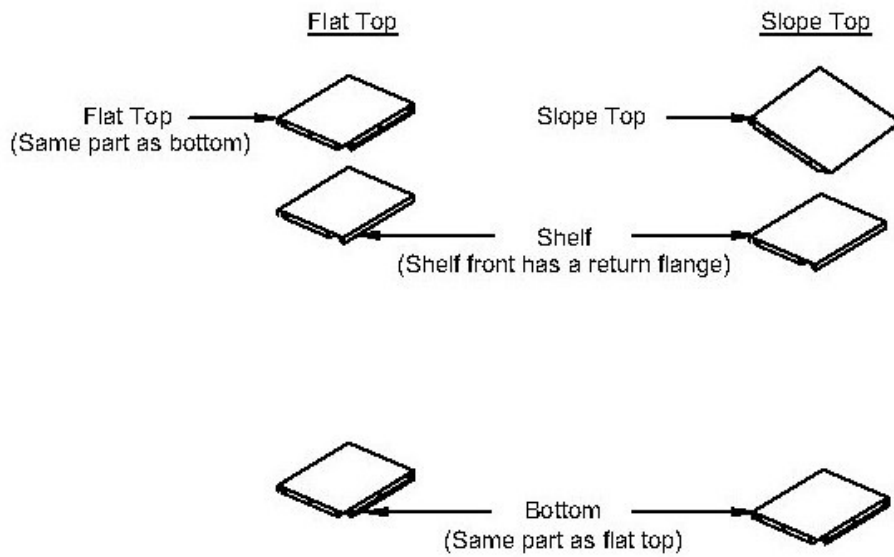

Locker Door & Frame Assemblies

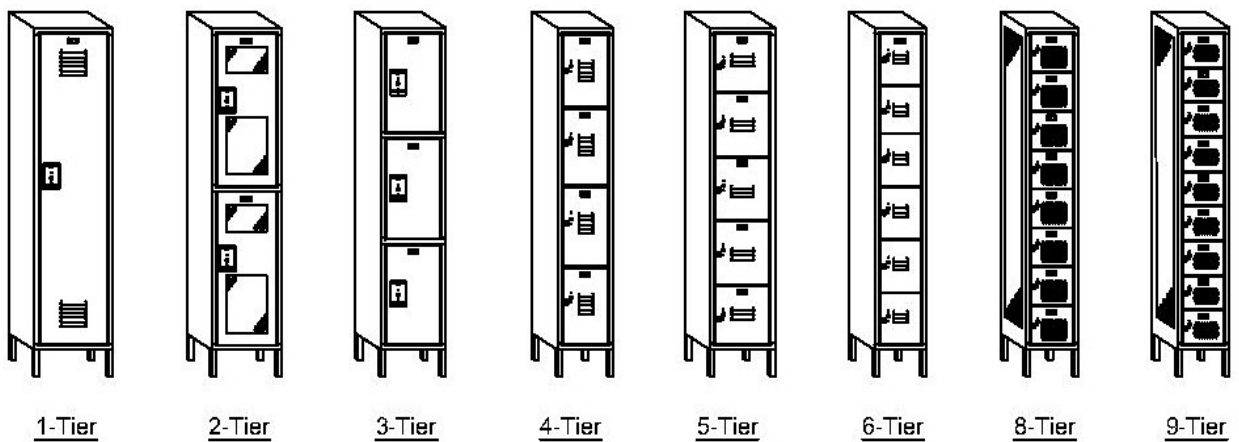

*Single row lockers must be floor and wall anchored
Double row lockers must be floor anchored and if possible wall or ceiling anchored.*

HARDWARE AND SMALL LOCKER PARTS

Not all parts come with all lockers. Check packing list for what parts are to be used with what models of lockers.

Number Plate and Rivet

To be riveted to top of locker door.

Single Prong Wall Hook

To be bolted to divisions and to back panel.

Single & Double Prong Ceiling Hook

To be bolted to bottom of shelf or top of locker.

Coat Rod Hooks with Rod

Hooks to be bolted to divisions with coat rod between, used in single tier, Duplex, 2,7,8 person and Dual lockers 18" or more in depth.

Hook Clip

Used to attach single prong wall hooks and coat rods in lockers with Diamond Perforated divisions at ends only.

Door Pull

Used on box locker door unless a built-in lock is used. To be mounted on inside of door with pull tab inserted through vertical slot in door.

Lock Hole Cover Plate

Used to cover hole in door when built-in locks are not used. To be mounted on inside of door.

Nuts and Bolts

Truss fin head bolt and nut for assembly of locker body parts. Tighten nut with a wrench or nut driver (bolt is tamper resistant so it has no slot for a screw driver).

Truss fin head bolt and nut for assembly of entire Competitive locker series. In the Durable and Durable Plus lockers this nut and bolt is used in joining locker groups, locker legs and 2 hooks with the partition between the hooks. Tighten nut with a wrench or nut driver (bolt is tamper resistant so it has no slot for a screw driver).

Sheet metal screw for slope tops only.

Optional Items That are Ordered Separately from Locker

Built-in Combination Lock

Used to secure locker door when padlock is not used. This lock replaces Lock Hole Cover Plate or Door Pull. To be mounted on inside of door. Lock may come from another supplier other than WEC.

Safe-O-Mat Coin Operated Lock

Used to secure locker door when padlock is not used. This lock replaces Lock Hole Cover Plate. Lock engages when token or coin is deposited.

Concrete Floor Anchor (1/4" x 2")

Used to secure locker to a concrete floor. Bolt type will vary with floor type.11

Combination Padlock

(9/32" or .281" Shackle)

Used to secure locker door when built-in lock is not used. Lock may come from another supplier other than WEC.

Built-In Key Lock

Used to secure locker door when padlock is not used. This lock replaces Lock Hole Cover Plate or Door Pull. To be mounted on inside of door. Lock may come from another supplier other than WEC.

Touch Up Paint

Used to touch up paint finish.
(Available in 24 standard colors)

*Single row lockers must be floor and wall anchored.
Double row lockers must be floor anchored and if possible wall or ceiling anchored.*

Hook And Coat Rod Guidelines

	1-Tier	2-Tier	3-Tier	4,5,6,7,8, & 9-Tier	2-Person	7-Person	8-Person	16-Person	Duplex	Dual
Single Prong Wall Hooks										
Depth Less Than 18"										
Width Less Than 15"	3	6	9	N/A	N/A	N/A	N/A	N/A	N/A	4
Width 15" or More	4	8	12	N/A	4	N/A	N/A	N/A	4	4
Depth 18" or More										
Width Less Than 15"	1	6	12	N/A	N/A	N/A	N/A	N/A	N/A	N/A
Width 15" or More	2	8	12	N/A	N/A	N/A	N/A	N/A	N/A	N/A
Double Prong Ceiling Hooks										
Depth 18" or More										
Width Less Than 21"	1	2	N/A	N/A	N/A	N/A	N/A	N/A	N/A	N/A
Width 21" or More	2	4	N/A	N/A	N/A	N/A	N/A	N/A	N/A	N/A
Coat Rod Hooks										
Depth Less Than 18"										
Depth 18" or More	2	N/A	N/A	N/A	4	2	4	N/A	4	4
Coat Rods										
Depth Less Than 18"										
Depth 18" or More	1	N/A	N/A	N/A	2	1	2	1	2	2

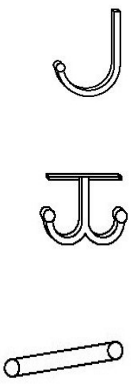
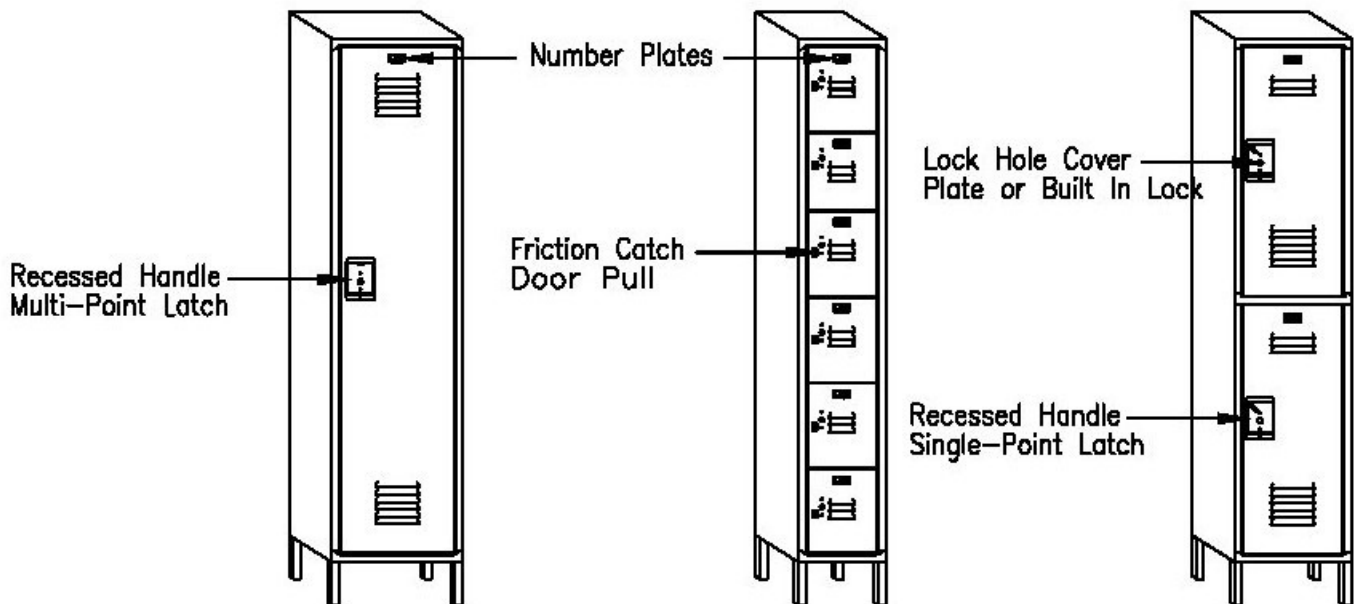

Illustration of Number Plate, Lock Hole Cover Plate or Built-in Lock Positioning



*Single row lockers must be floor and wall anchored.
Double row lockers must be floor anchored and if possible wall or ceiling anchored.*

Multi-Tier Assembly Instructions

Assemble lockers using the Single or Double Tier Instructions, during Operation 2 add the appropriate shelf, top, bottom or partition.

Shelf Spacing Guidelines

Single tier lockers have a shelf approx. 9" below the top of the locker.

For Multi-tier lockers take the height of the locker and divide the number of doors to get shelf spacing.

EXAMPLE: Height: 72", Number of Doors: 6.

$72"/6 = 12"$ distance between shelves.

Locker doors and frames can also be used as a template for shelf or flat top (T.A.B.) positioning.

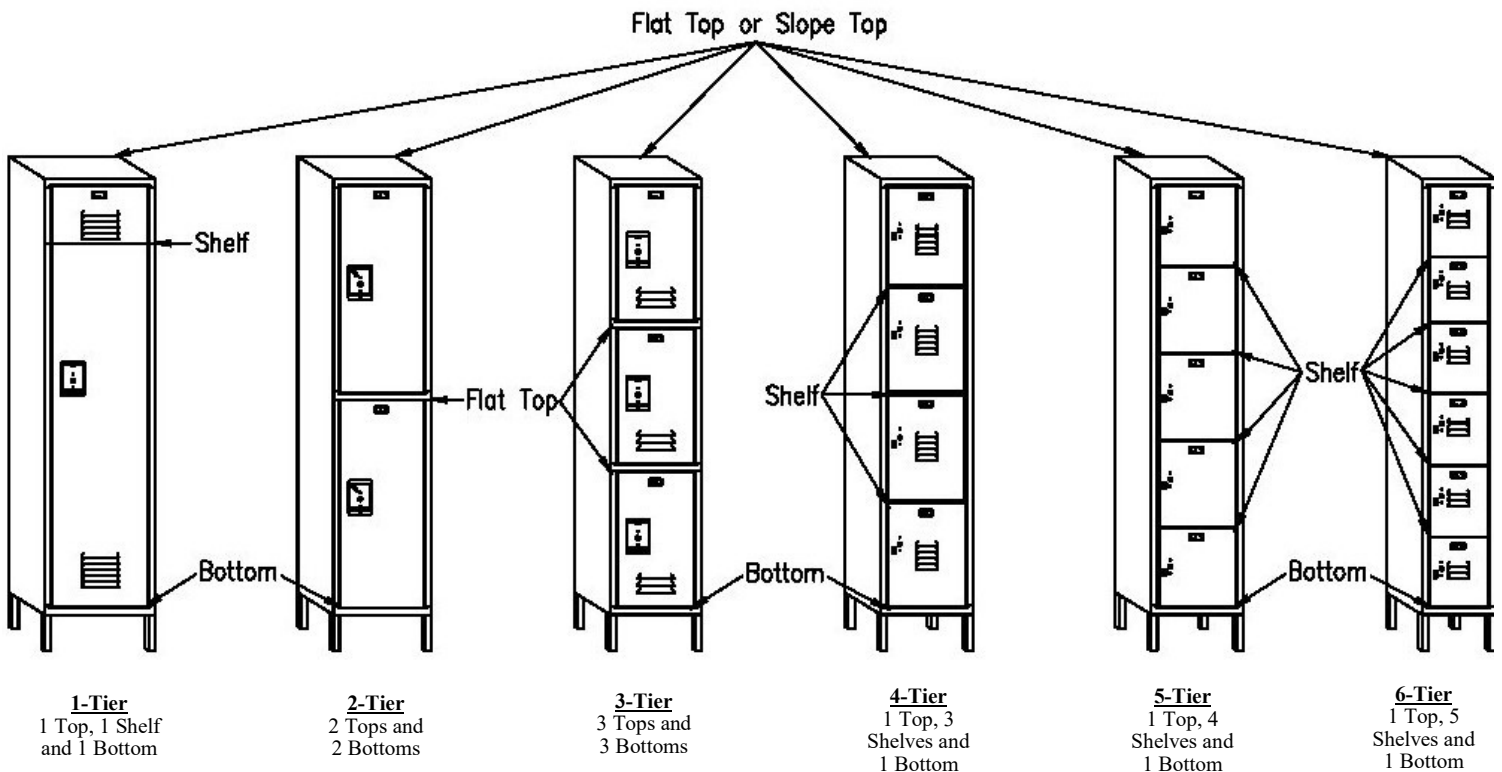

The hole punching pattern on Divisions are the same for all lockers EXCEPT for 5-Tier Lockers and 16 gauge Exposed End Panels.

*Single row lockers must be floor and wall anchored.
Double row lockers must be floor anchored and if possible wall or ceiling anchored.*

INDIVIDUAL CLOSED BASES

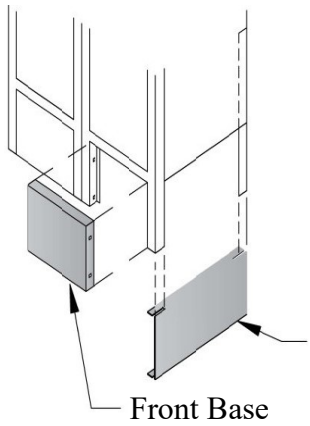

Front and end bases are designed to fit between standard 6” legs. The front bases snaps in between the front legs. The end base slips over legs during assembly.

1. Before standing locker up and placing the locker in position, slide the End Base up the leg of the locker row.
2. Stand locker up and put the locker in proper position.
3. Snap Front Base between the front legs of each locker so that the two tabs on either side of Front Base match up with the square slots in the front legs.

End Base *(Available in single or double row)*

Front Base

ZEE BASE: Lockers to be anchored to wall

Zee Base raise lockers without legs off the floor and provides a continuous closed base. It is used when there is no concrete or wood bases. Available in 72” length only. The zee base shall be cut by installer when shorter lengths are needed.

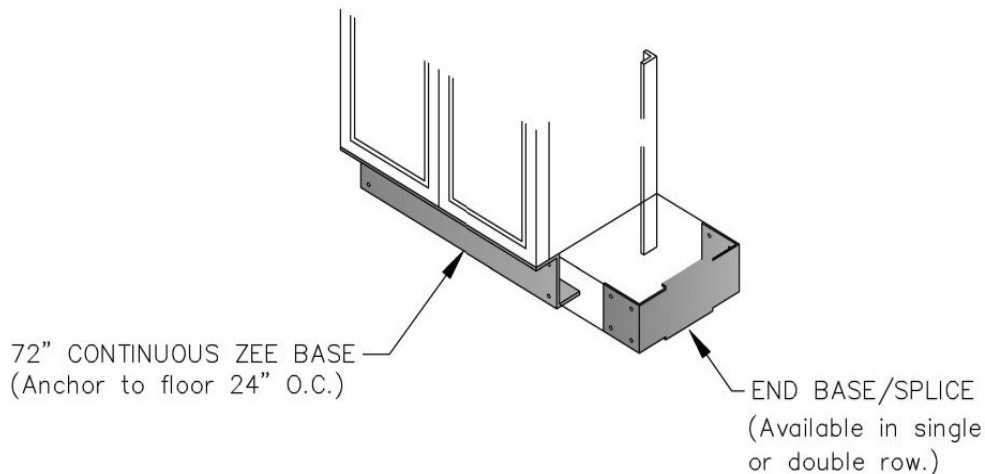

1. Match Zee Bases and Splice/End Bases to lockers, site plan and installation location.
2. Use Splice/End Base as a template to position Zee Base.
3. Place Splice/End Base flush against wall (thinner side with holes) or create a chalk line as a positioning guide.
4. Create a chalk line for Zee Base positioning using Splice/End Bases as a measuring device.
5. Butt Zee Base against other side of Splice/End Base.
6. Measure locker depth and make sure Locker Door Frame will rest on Zee Base. (there should be a 1/4" space between the end of Zee Base and outside edge of Locker Door Frame).
7. Use the two sets of holes on the Splice/End Base to bolt together 2 lengths of the Zee Base.
8. Recheck measurements of Locker, Zee Base position, and site plans.

9. Anchor Zee Bases and Splice/End Base to floor with proper drill and bolt for the floor surface.
10. Assemble Single Row Lockers as per instructions on page 4 or assemble Double Row Lockers as per instructions on page 8 except when installing Door and Door Frame leave bolts at bottom of Door Frame off.
11. Place assembled locker on Zee Base (there should be a 1/4" space between the end of Zee Base and outside edge of Locker Door Frame).
12. Use the bottom hole of the Door Frame to position drill and drill a 1/4" hole through the top of the Zee Base.
13. Place bolt through Door Frame and Zee Base. Place nut on Zee Base side of bolt and tighten. Repeat steps 12 and 13 for each door.

*Single row lockers must be floor and wall anchored,
double row lockers must be floor anchored Single row lockers must be floor and wall*

Individual Slope Tops

Individual Slope Tops are used with Slope Top Divisions. One Slope Top covers the width of one locker frame. (Not for use on Competitive or All-Welded lockers).

1. Open door to locker so you have access to top of locker
2. Bolt unit slope top to divisions and back.
3. Insert sheet metal screws up the hole in the top of the door frame and fasten the front of the unit slope top to locker
4. Repeat steps 1-3 as needed.

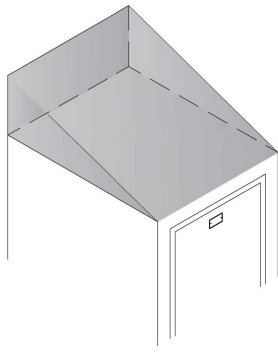

Size (Inches)	
Width	Depth
9	12
	15
	18
12	12
	15
	18
	21
15	12
	15
	18
	21
18	18
	21
	24
24	18
	21
	24

Slope Hoods		Slope Ends
Size (Inches)		Size (Inches)
Width	Depth	Depth
72	12	12
	15	15
	18	18
	21	21
	24	24

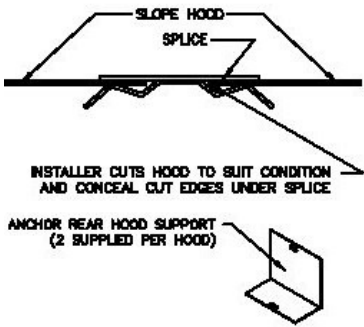

Continuous Slope Hoods

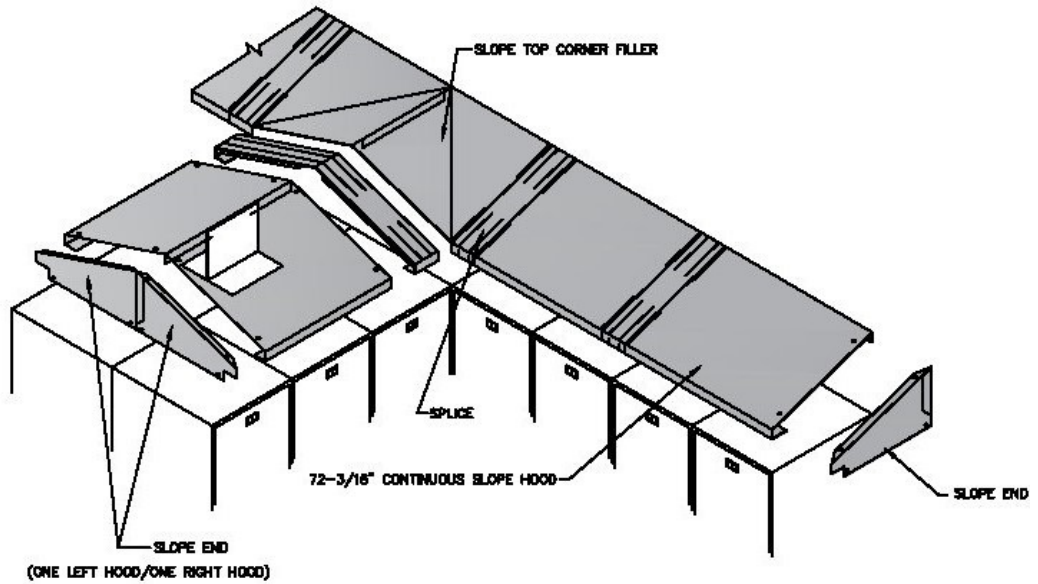

TYPICAL INSTALLATION

Single row lockers must be floor and wall anchored, double row lockers must be floor anchored and if possible wall or ceiling anchored.

Slope Top Kits

Designed to convert stock Flat Top lockers into Slope Top lockers in groups of 3 wide. Each kit contains 3 tops, 3 backs and 4 ends. (Not for use on Heavy Duty or All-Welded lockers).

Size (Inches)	
Width	Depth
12	12
	15
	18
15	15
	18

1. If there is a Flat Top (T.A.B.) on locker, remove bolts on sides and back.
2. Bolt Slope End to inside of locker
3. Bolt Slope Back to outside of locker back and inside of Slope End.
4. Bolt Slope Top to sides and back.
5. Insert sheet metal screws up the hole in the top of door frame and fasten the front of the Slope Top to locker.
6. Repeat steps 1-5 as needed.

