

# CONDUITS, PIPES AND CULVERTS ASSOCIATED WITH DAM AND LEVEE SYSTEMS ENGINEER MANUAL (EM) 1110-2-2902

Christina Neutz, PE, SME  
Project Lead on Rewrite of EM 2902  
Levee Safety Section Chief  
LRD/LRL/Levee Safety  
Date: 9 December 2020



US Army Corps  
of Engineers®



# PURPOSE & APPLICATION



EM 2902 provides risk informed guidance for the life cycle of conduits, pipes, and culverts associated with USACE constructed dam and levee projects.



# CHAPTER 1



## Chapter 1 - Overview

Chapter 1 defines

Terminology:

- Levees
- Landside and Waterside
- USACE Civil Works Project
- Conduits, Pipes, and Culverts
- Essential vs. Non-essential Pipes
- Pipes that Can Impact the Integrity of a Levee
- Pipes that Cannot Impact the Integrity of a Levee
- Levels of Adherence

Hydraulic Capacity

Requests for Altering Existing USACE Civil Works Projects with Respect to Pipes

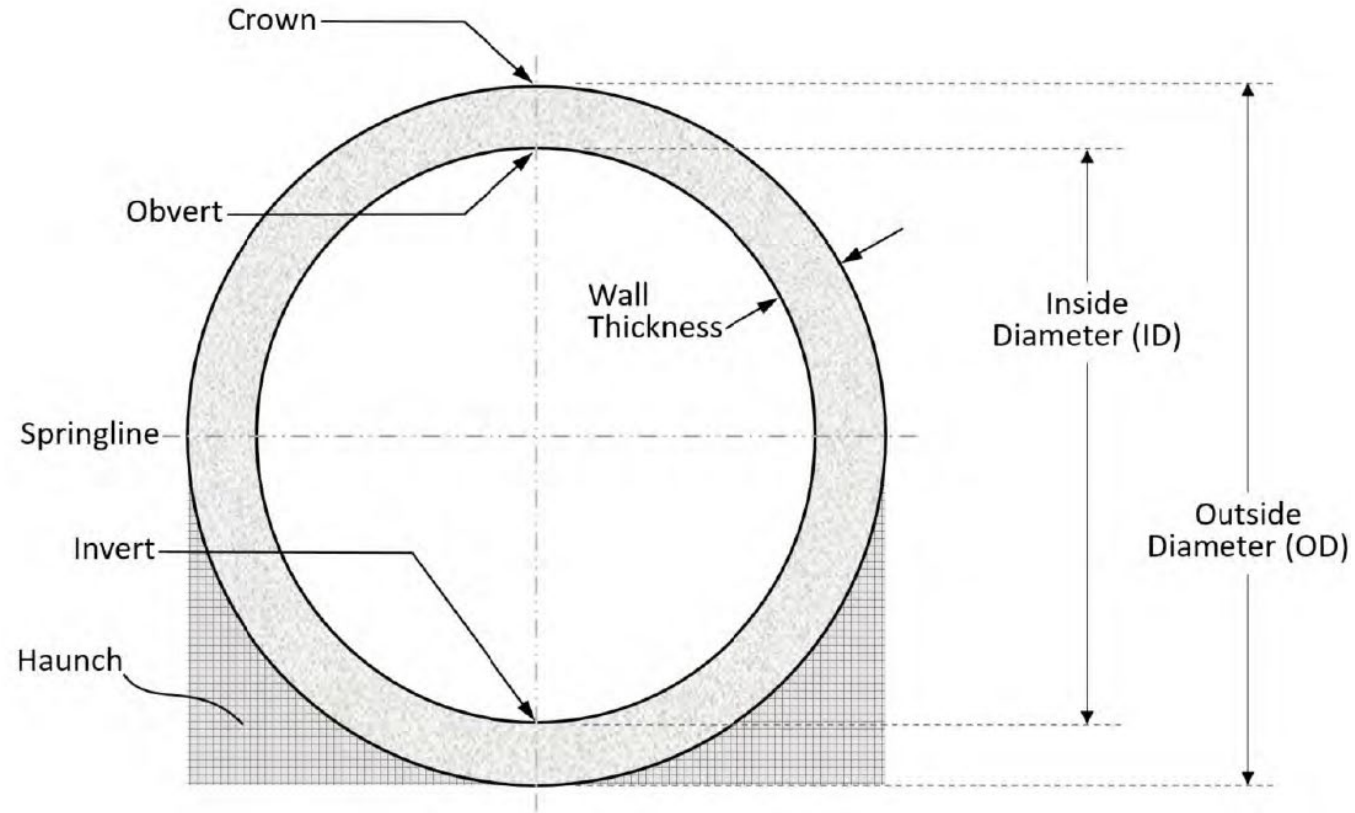

Figure 1-7. Typical pipe nomenclature.

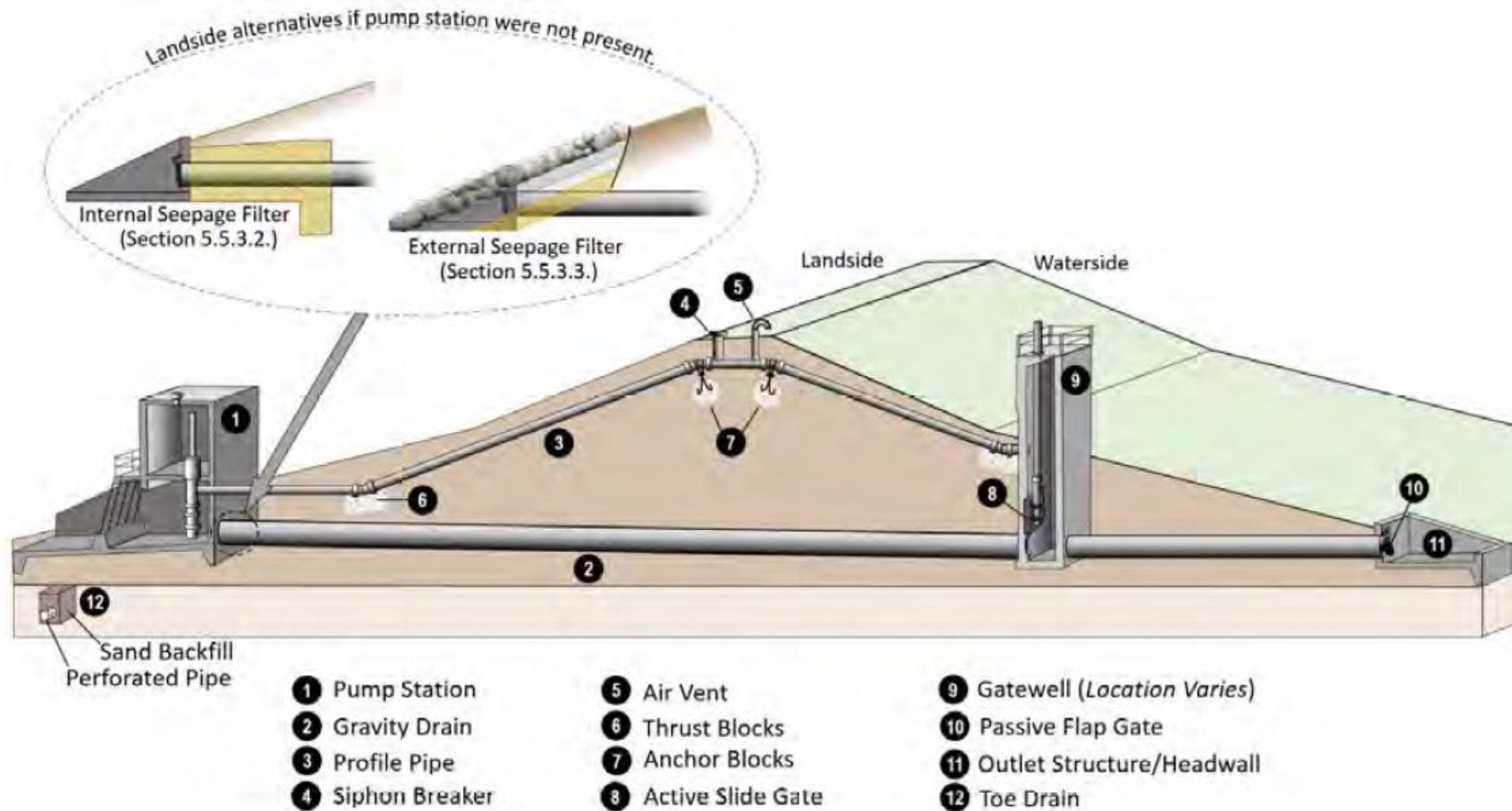
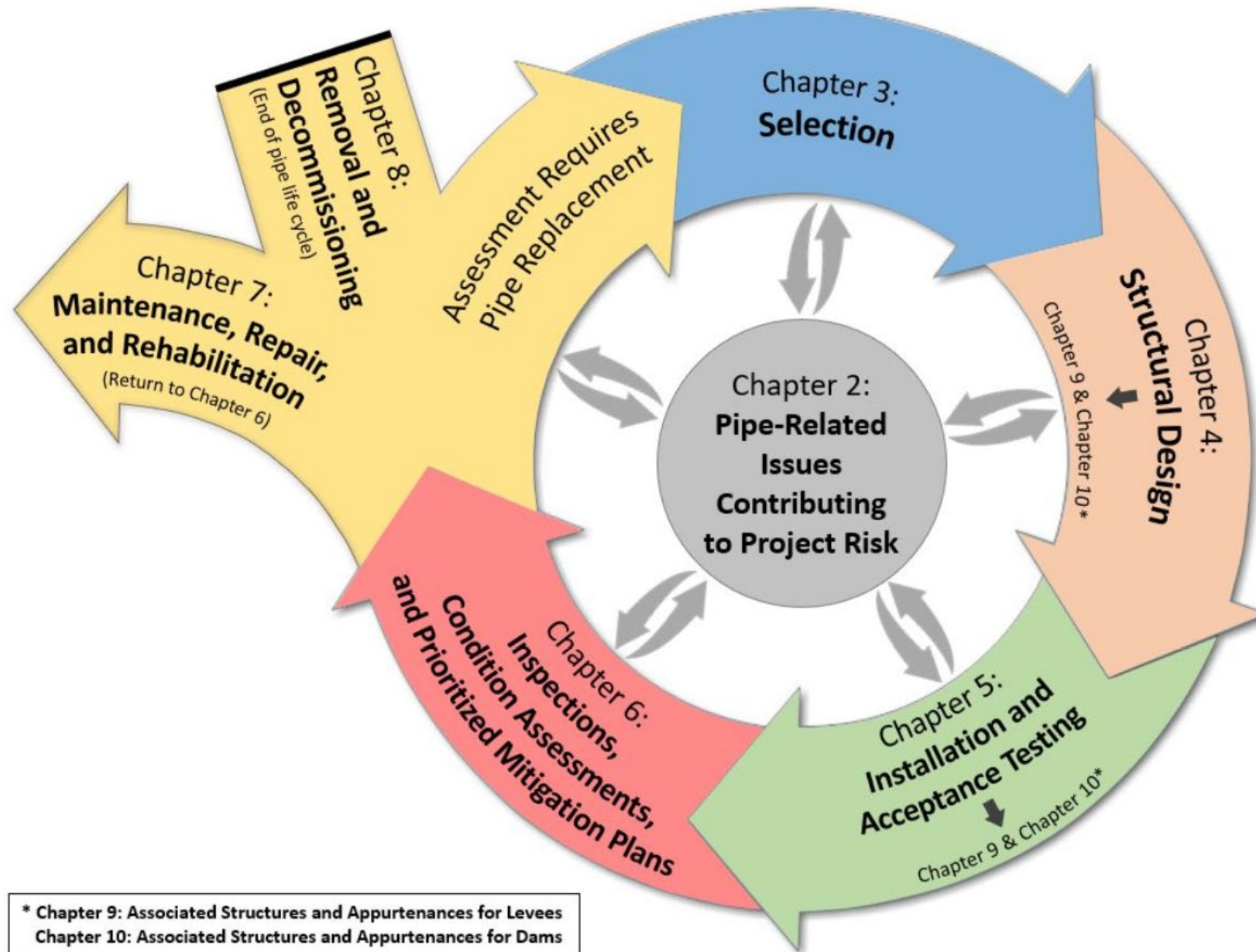

Figure 1-8. Typical associated structures and appurtenances common to pipes through levees.

## Pipe System Anatomy



# OVERVIEW – EM LAYOUT - LIFE CYCLE OF A PIPE





# CHAPTER 2



## Chapter 2 – Pipe-Related Issues Contributing to Project Risk

Chapter 2 introduces the concept of risk as characterized by USACE and provides examples that show how the presence of pipes associated with embankments or floodwalls has the potential to increase the overall project risk by increasing the probability of structure breach, or even causing interior ponding without a breach.

Internal erosion accounts for nearly half of all embankment failures with many of those failures occurring along pipes.



## CHAPTER 2

Potential failure mode (PFM) describes the chain of events leading to an embankment or floodwall breach that allows the uncontrolled release of water or to interior inundation without a breach, either of which results in adverse consequences.

PFMs are used to explain the pipe-related vulnerabilities that influence the “performance” variable.

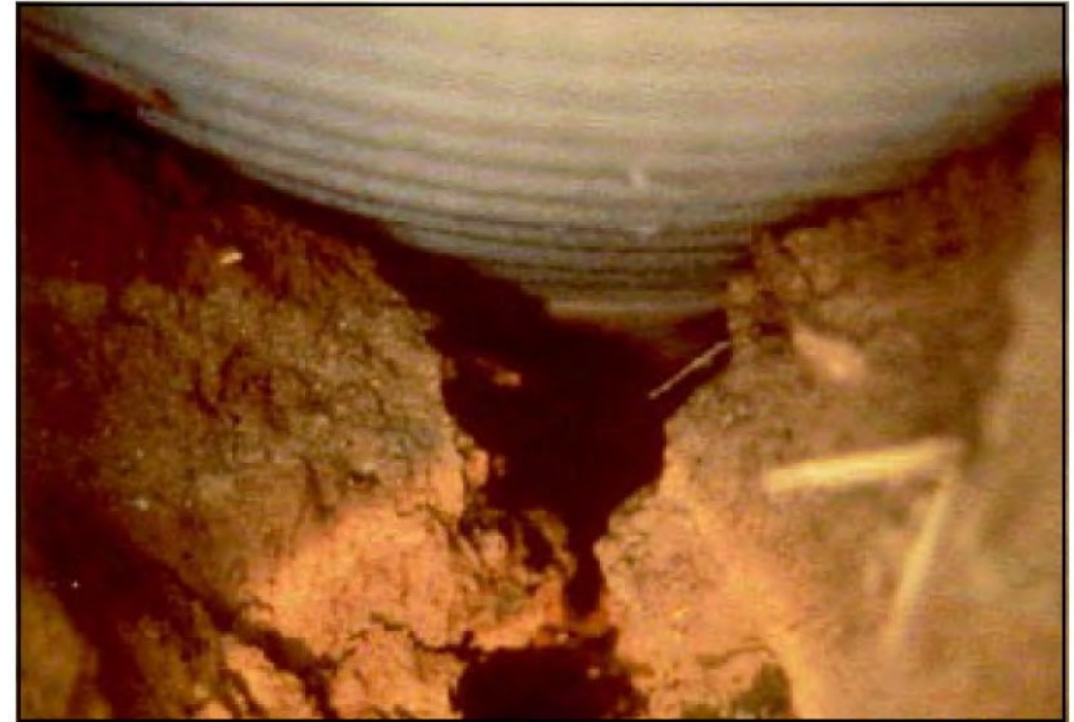

(From Low-Volume Roads Engineering, USDA-Forest Service, 2003)

Figure 2-6. Substantial void space beneath pipe caused by poorly placed backfill.



# PFM 1



## PFM-1 – Internal Erosion along a Pipe.

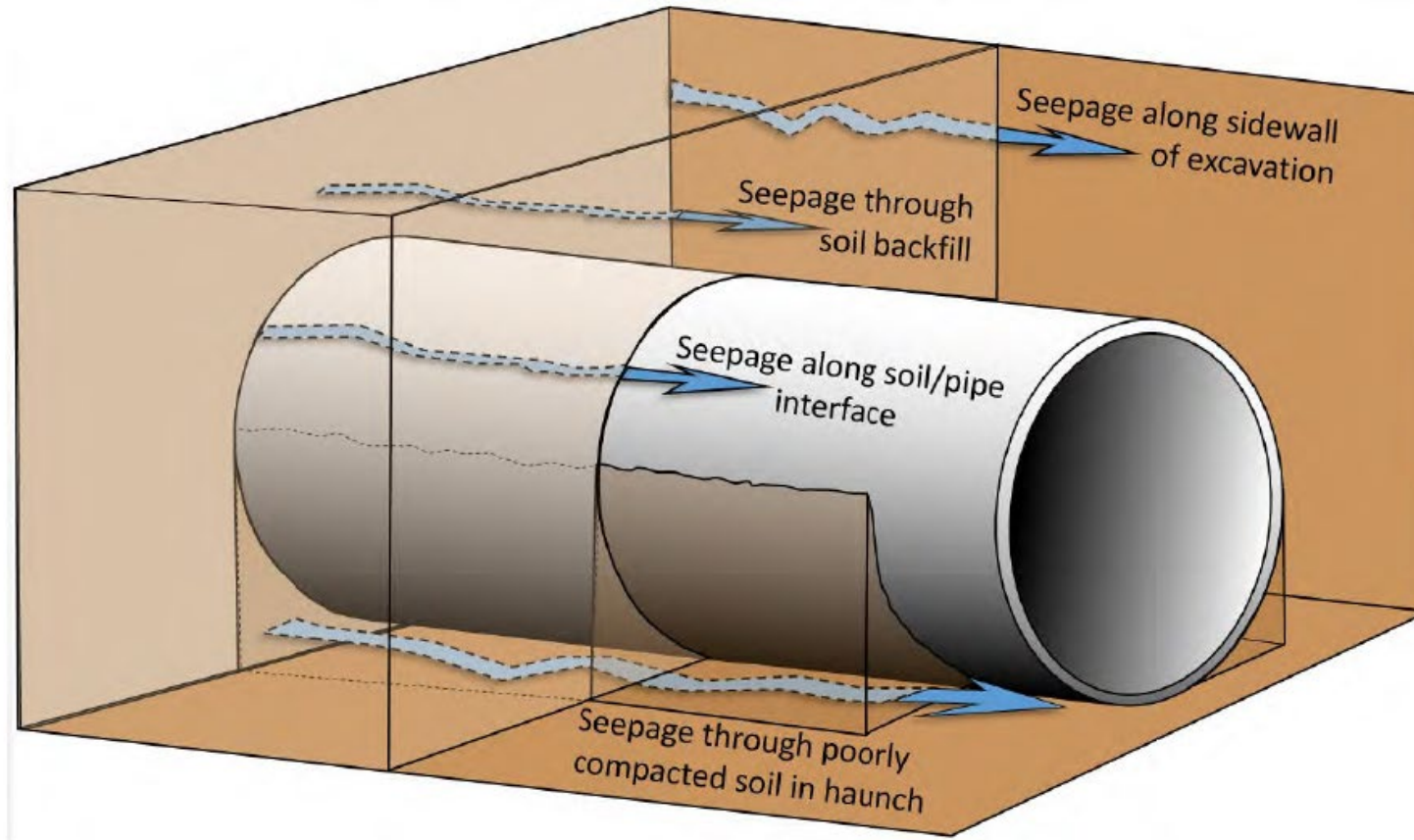

Figure 2-4. Soil backfill zones where potential flaws could promote PFM-1.



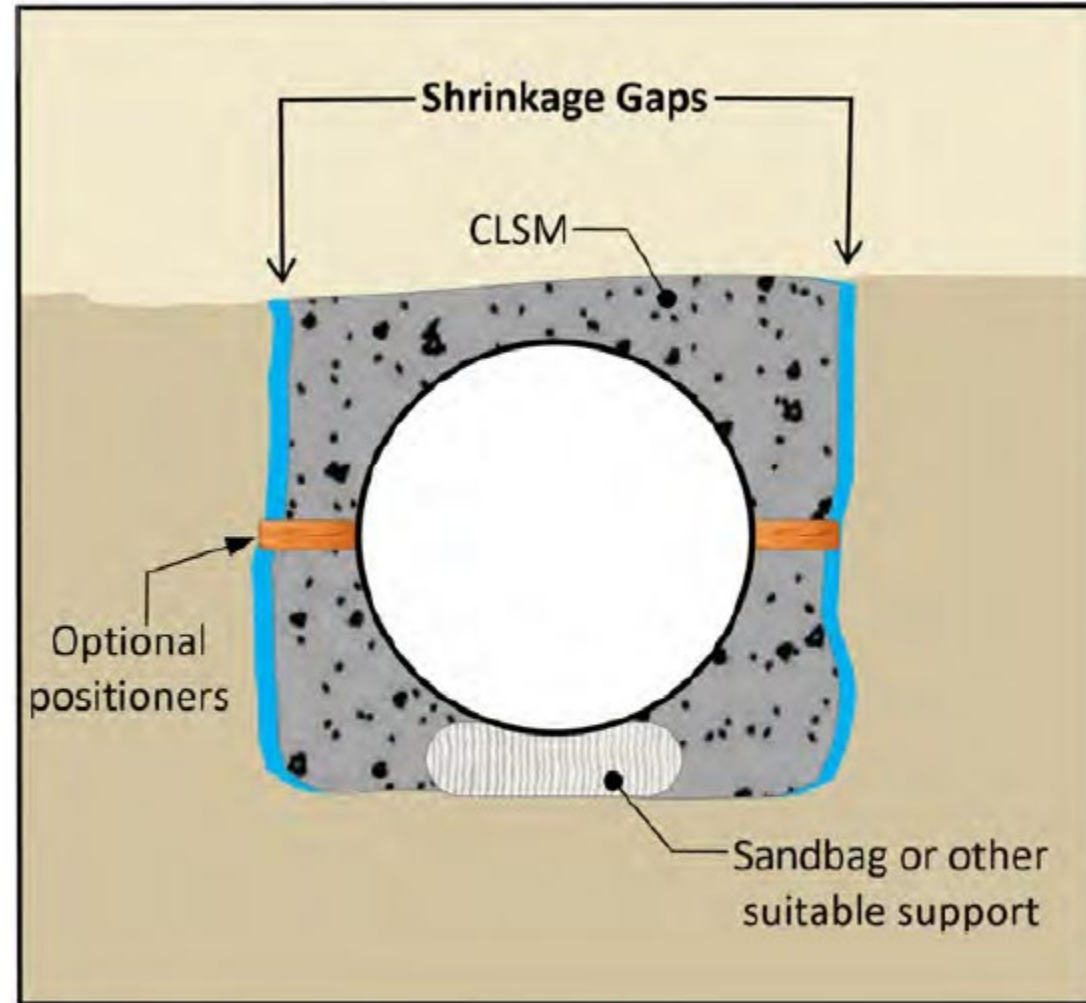

Figure 2-7. Potential flaw within CLSM-filled trench that may promote PFM-1.

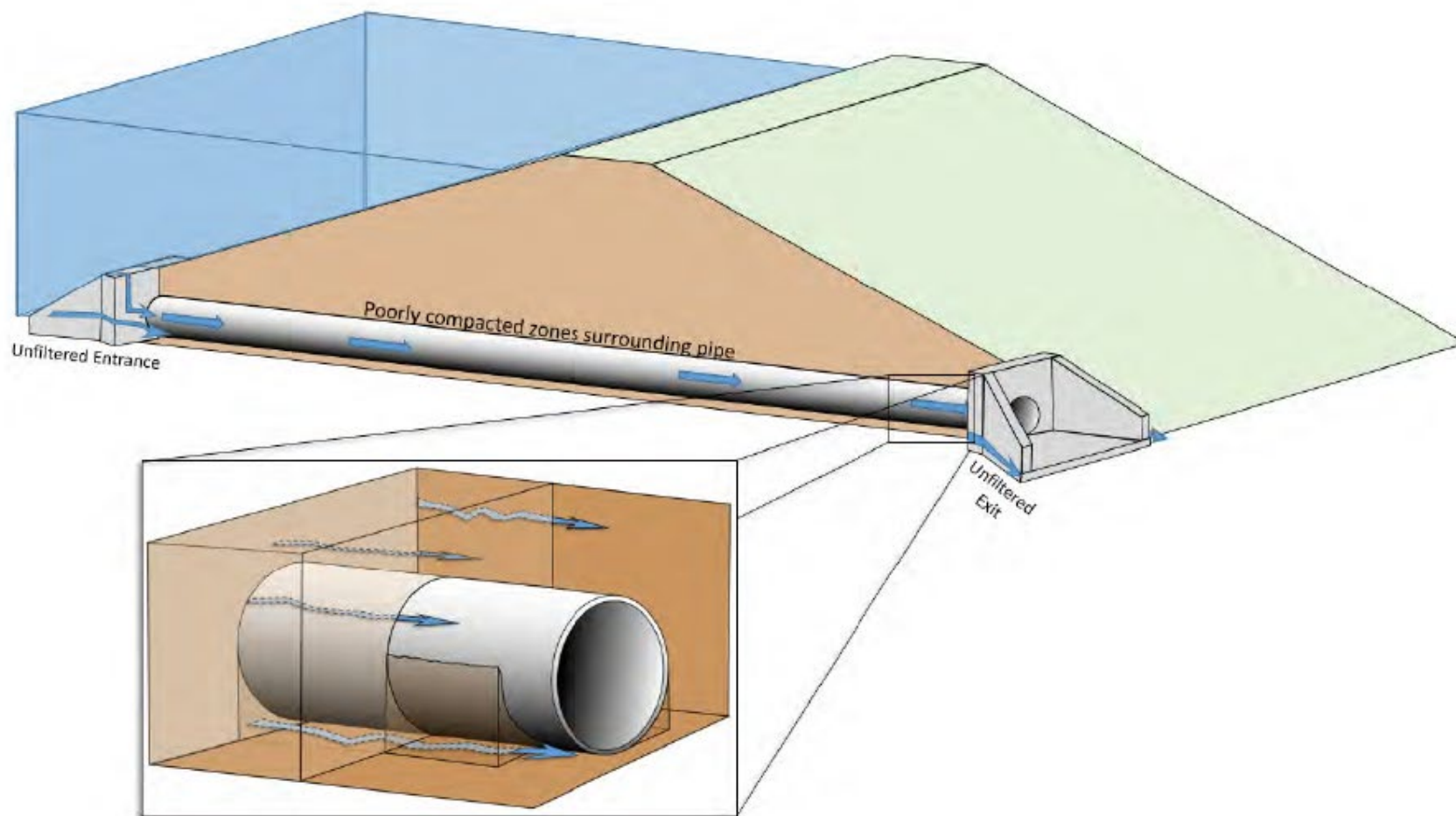

Figure 2-8. Unfiltered pipe ends allow seepage to initiate internal erosion.



# PFM 1

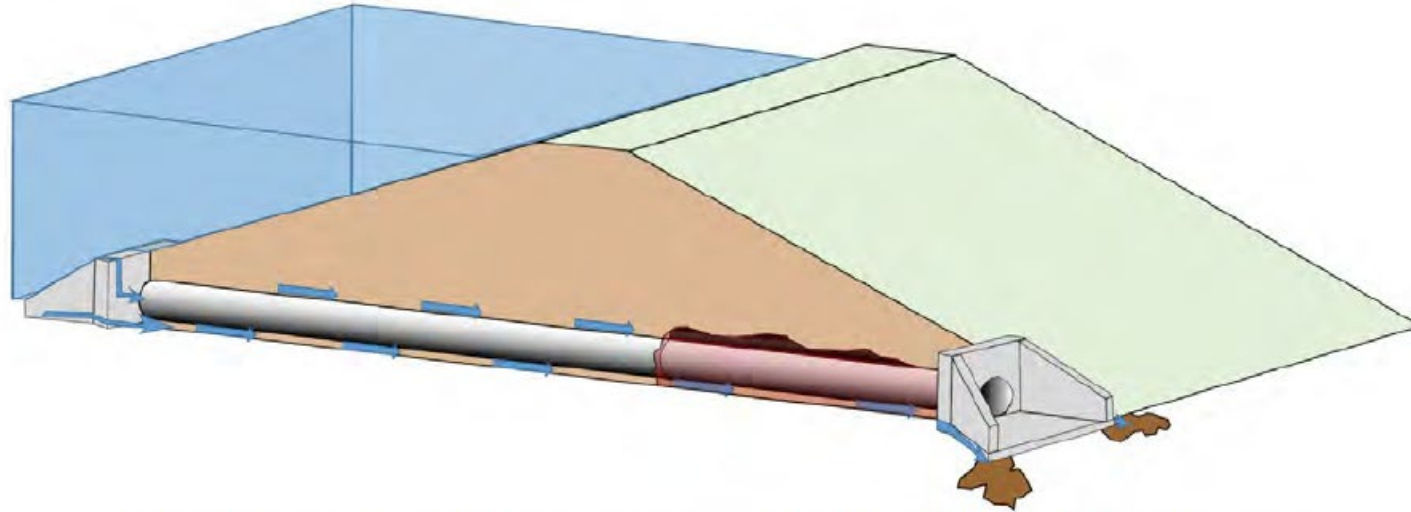

Figure 2-9. Soil removal begins and erodes along the pipe toward the water source.

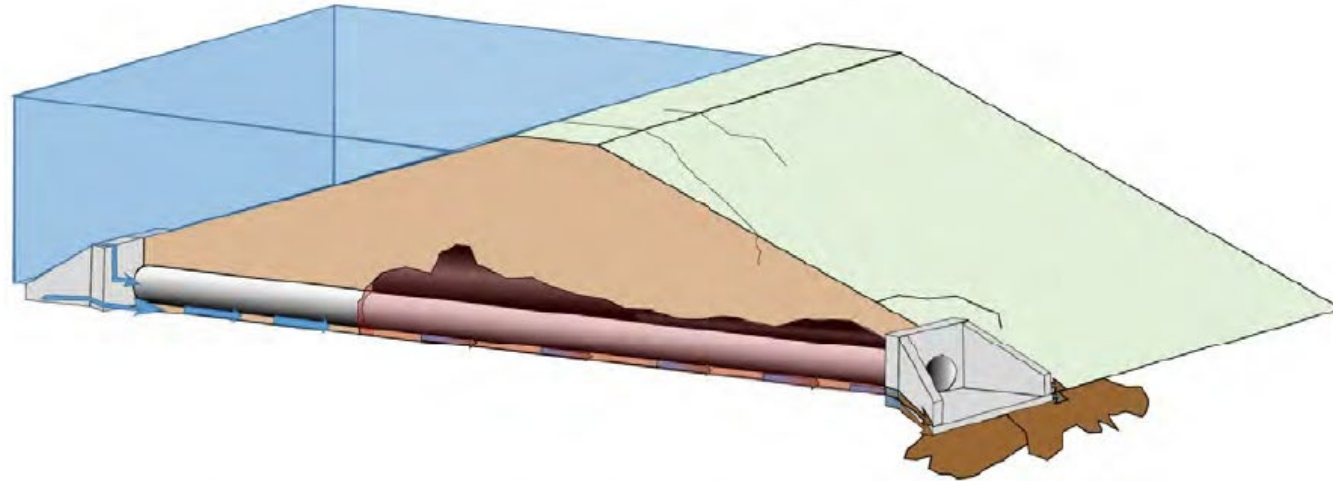

Figure 2-10. Progression of failure mode begins to create observable distress.

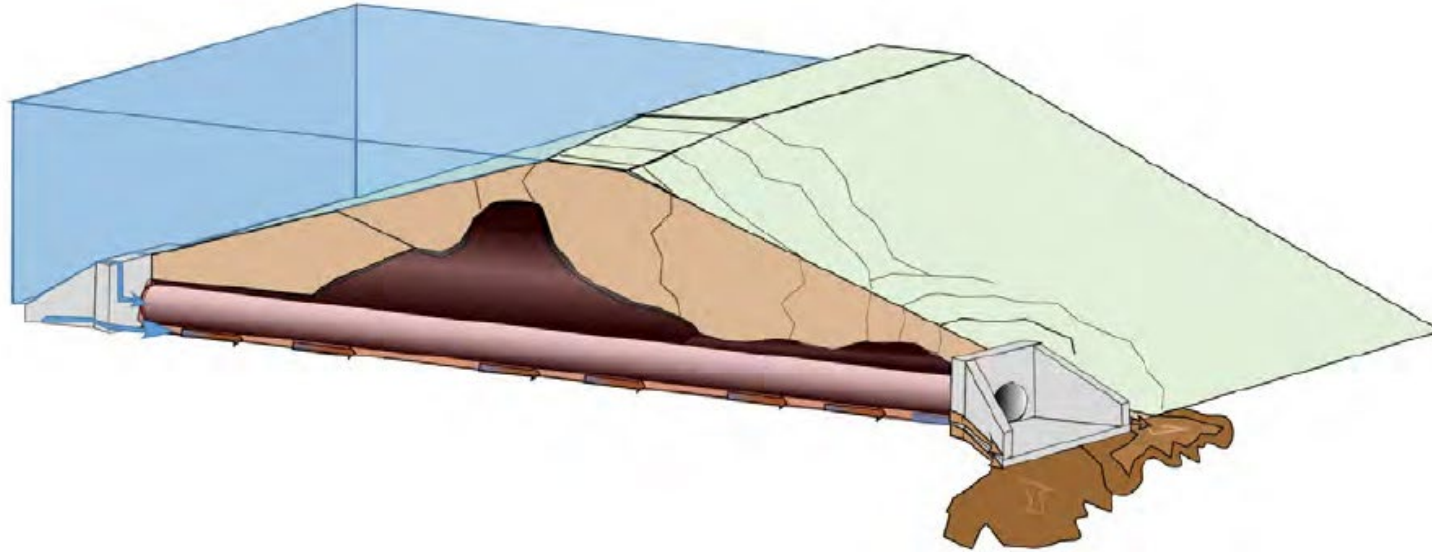

Figure 2-11. Continued progression increases distress and alters the embankment geometry.

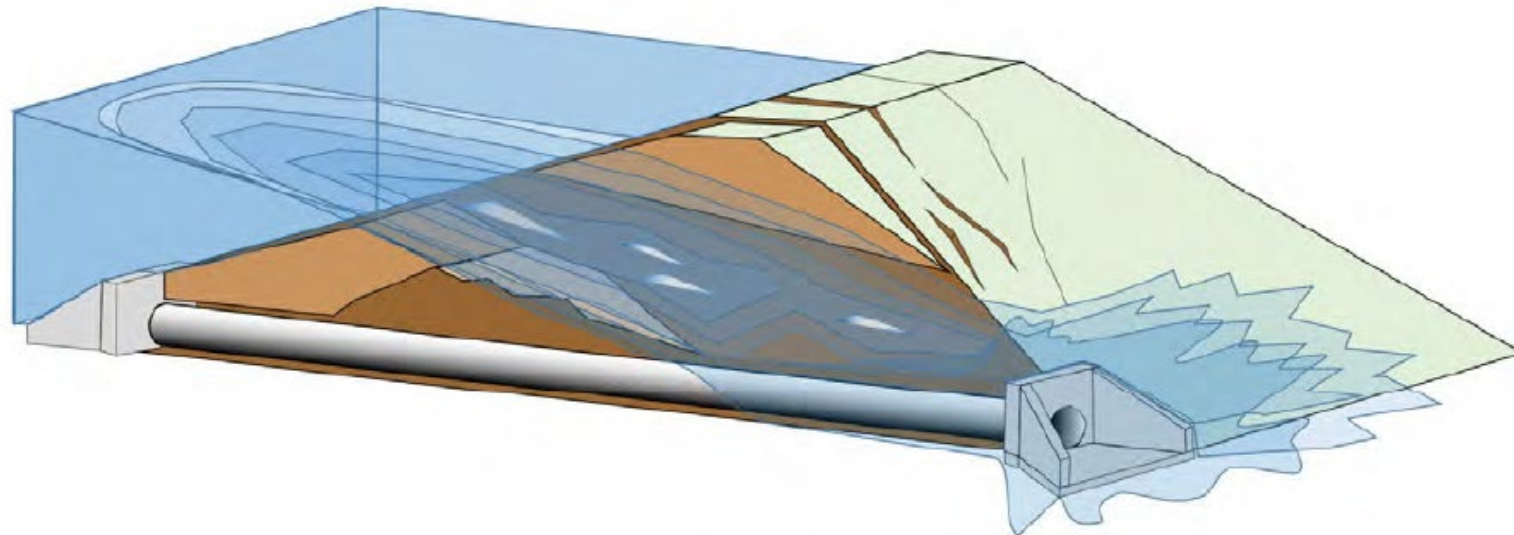

Figure 2-12. Intervention is not possible or unsuccessful and a collapse and breach occurs.

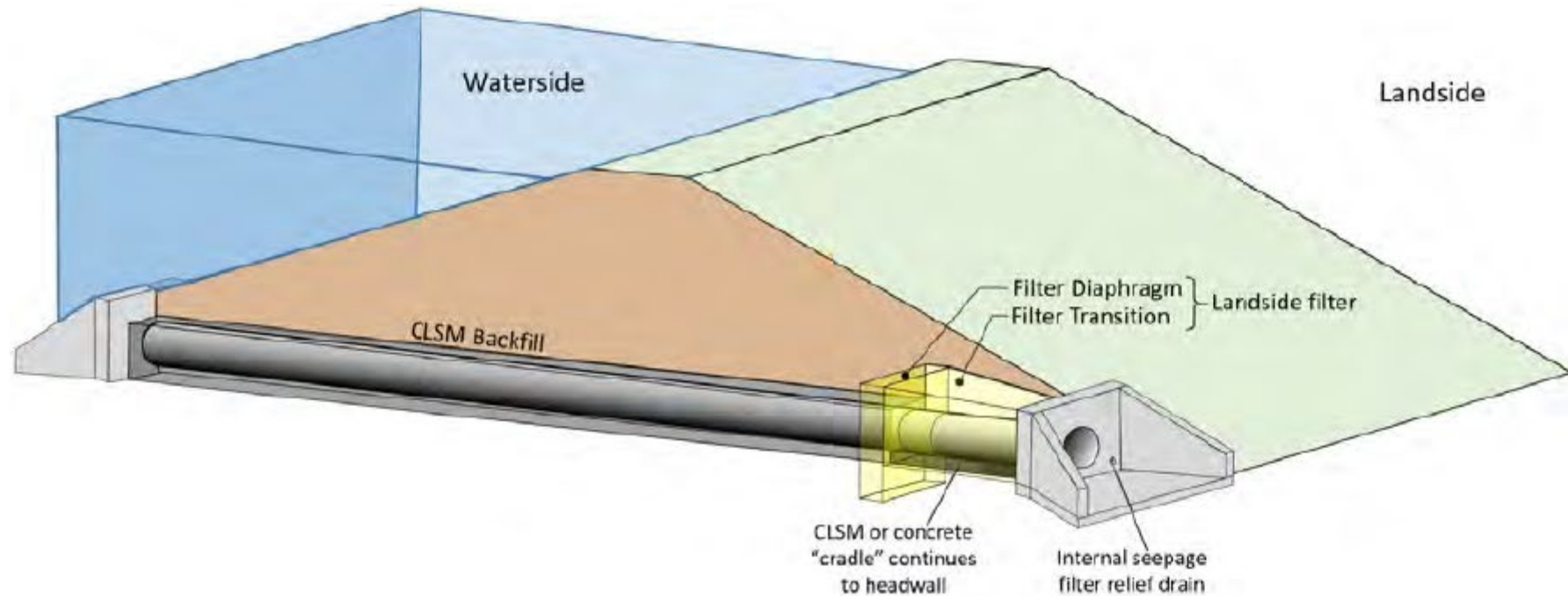

Figure 2-13. Internal seepage filter used to capture and safely release seepage along the pipe.



# PFM 2



## PFM-2 – Internal Erosion from Leakage of a Pressurized Pipe.



(Courtesy of USACE Louisville District)

Figure 2-14. Trapped interior water (pressurizing pipe) exits through corrosion holes.

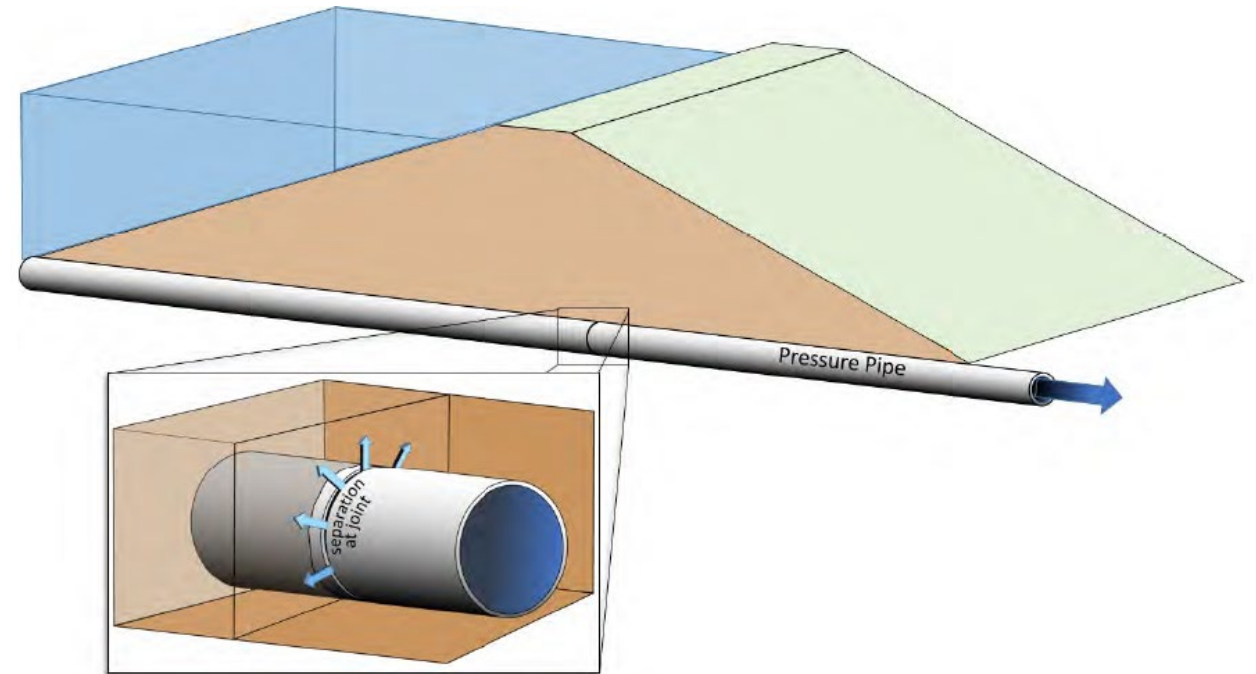

Figure 2-15. Flaw allows release of pressurized fluid into embankment.



# PROACTIVE MEASURES AND INTERVENTION



To reduce the probability of PFM-2 occurring, non-essential pressure pipes are prohibited within an embankment unless the crest supports infrastructure that cannot be disrupted.

Requiring new pressure pipes to include shutoff valves to address the potential release of fluids into or onto the embankment will provide the ability to stop flow and minimize damage.



# PFM 3



## PFM-3 – Internal Erosion into a Pipe



(Courtesy of USACE Louisville District)

Figure 2-23. Holes in a pipe allowed continued soil loss to create a sinkhole in the levee crest.





# PFM 4



## PFM-4 – External Erosion at the Pipe Outlet.



(Courtesy of USACE Louisville District)  
Figure 2-47. Drainage pipe outlet erosion.



(Courtesy of USACE Louisville District)  
Figure 2-48. Result of successive slope failures around pipes.



# PROACTIVE MEASURES AND INTERVENTION



Regular inspections will reveal erosion, and the rating and associated narrative should indicate the urgency of the repair.

Actions to correct deficiencies during normal water levels may be as simple as light regrading and riprap placement below outlet structures with minor erosion, whereas more advanced cases may require excavation by heavy equipment and outlet structure/partial pipe reconstruction/installation.

Routine maintenance can typically prevent damage from this failure mechanism well before advanced stages are reached.



# PFM 5



## PFM-5 – Internal Restriction Causes Interior Ponding.



(From Trenchless Technology Magazine, 2019)

Figure 2-54. Pipe deformation that could restrict flow and cause interior ponding



(Courtesy of Lizotte Solutions)

Figure 2-55. Internal debris accumulation severely restricting flow.



# PROACTIVE MEASURES AND INTERVENTION



Prior to a rainfall event, proactive measures include removal of debris within the drainage area and the installation of trash racks/debris screens near the pipe entrance.

For cases where there is no debris screen or it is ineffective, removal of trapped debris from within a pipe during a high-water event is essentially impossible, and the only viable intervention technique is the use of portable pumps to remove interior water.



# PFM 6



## PFM-6 – External Restriction Causes Interior Ponding



(Courtesy of Forest Hills CONNECTION, Marlene Berlin)

Figure 2-56. External debris accumulation severely restricting flow.



# PROACTIVE MEASURES AND INTERVENTION



Prior to a rainfall event proactive measures include removal of debris within the drainage area, removal of debris deposited near the pipe entrance from previous events, the installation of debris screens, and oversizing the drainage feature for a reasonable degree of blockage.

Intervention during a rainfall event involves attempting to remove accumulated debris at the pipe entrance so the area can freely drain.

Oversaturation and remote locations may make successful intervention and the use of heavy machinery infeasible. In many cases portable pumps can be mobilized to the affected area to remove the water.



(From SPEC-NET, 2017)

Figure 2-57. Fabricated debris screen for poured-in-place headwall.



# PFM 7



PFM-7 – Appurtenance Malfunction Causes Interior Ponding/Flooding.

The appurtenances most likely to cause interior ponding or flooding are gates.

Flap, slide, and other gates can become seized in various positions and either allow water to flow into the leveed area during a flood or prevent or hinder normal drainage.



# PROACTIVE MEASURES AND INTERVENTION



Regular inspections and proper lubrication of the gate mechanisms are proactive measures to preserve gate operability.

Intervention in the case of floodwater entering the leveed area through an open pipe could be accomplished by dropping sandbags in front of the flap gate or down a gatewell in front of a slide gate.

Portable pumps could then be deployed to remove any seepage or ponded interior water.

When waterside intervention is not possible or practical, a landside containment berm may successfully confine the ponding to a smaller area.







# CHAPTER 3



## Chapter 3 – Selection

Chapter 3 describes the pipe selection process by detailing the strengths and weaknesses of various pipe materials and their associated joints.



(Courtesy of American Concrete Pipe Association)  
Figure 3-1. Installation of precast RCP.



# PIPE MATERIALS



The Chapter 3 covers discussion on the following pipe materials listed:

## – Cast-in-Place Concrete Pipe (CiPCP)

## – Precast Reinforced Concrete Pipe (RCP)

- Non-Pressure and Low-Pressure Reinforced Concrete Pipe
- Round non-pressure RCP
- Arch and elliptical non-pressure RCP (NP-RCP)
- Low-pressure RCP (LP-RCP)
- Reinforced Concrete Box Use in Levee and Dam Applications
- Concrete Pressure Pipe (CPP)

## – Vitrified Clay Pipe (VCP)

## – Corrugated Metal Pipe (CMP)

- Corrugated Steel Pipe (CSP)
- Corrugated Aluminum Pipe (CAP)

## – Smooth Steel Pipe

- Seamless (Billet) Steel Pipe
- Spiral Welded Seam Steel Pipe
- Straight Welded Seam Steel Pipe

## – Ductile Iron Pipe (DIP)

## – Plastic Pipe

- Thermoplastics
- Solid-wall HDPE (SW-HDPE)
- Double-wall Containment HDPE
- Single-wall Corrugated HDPE
- Profile-wall (PW; also known as dual-wall) Thermoplastic Pipes (PW-HDPE, PW-PP, and PW-PVC)

## – Steel-Reinforced Thermoplastic Pipe (SRTP).

## – Fiberglass Reinforced Pipe (FRP)



# EXAMPLES



(Courtesy of National Corrugated Steel Pipe Association)  
Figure 3-4. Installation of a corrugated steel box culvert.

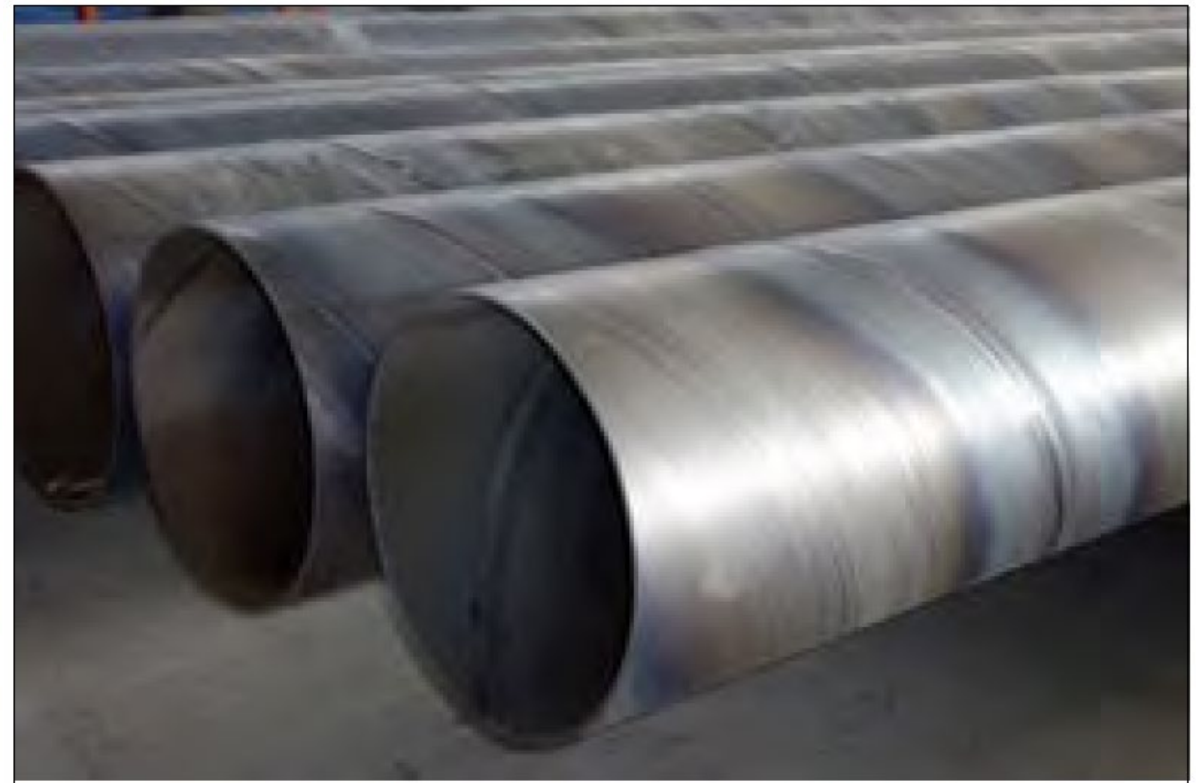

(Courtesy of National Association of Steel Pipe Distributors)  
Figure 3-7. Completed spiral welded seam steel pipe.



# EXAMPLES



(Courtesy of Ductile Iron Pipe Research Association)  
Figure 3-10. Finished DIP at manufacturing facility.



(Courtesy of Plastics Pipe Institute)  
Figure 3-12. Solid-wall HDPE at manufacturing facility.



# EXAMPLES



(Courtesy of Plastics Pipe Institute)  
Figure 3-15. Manufacture of a PW-HDPE.

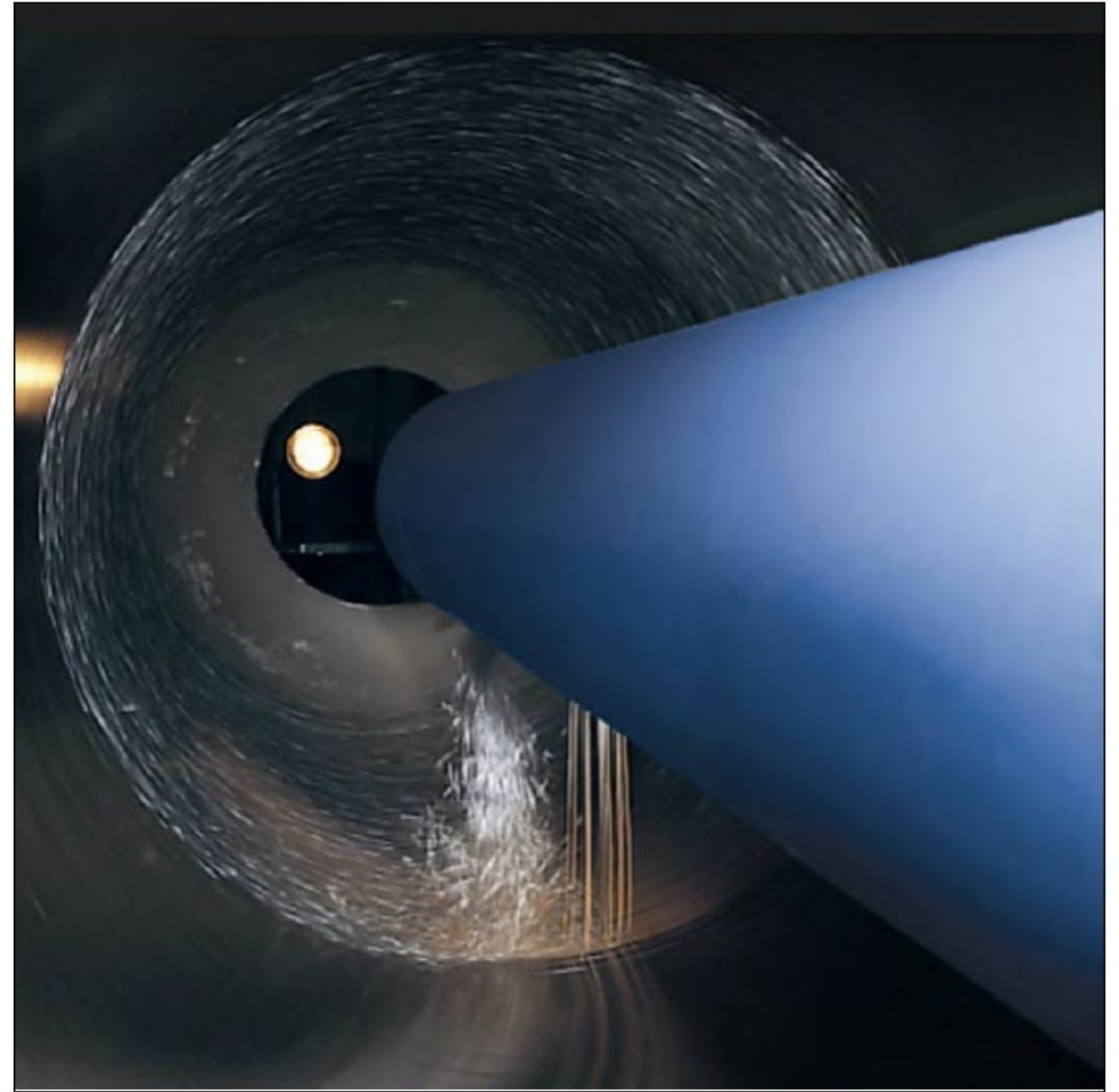

(Courtesy of Fiberglass Tank and Pipe Institute)  
Figure 3-17. Centrifugally-cast FRP.



# CONSIDERATIONS FOR SELECTION



The following are factors to consider in pipe selection:

- Pipe Function
- Hydraulic Requirements
- Available Standard Shapes and Sizes
- Load Carrying Capacity
- Corrosion Environment
  - Causes of Corrosion
    - Unusually Corrosive
    - Severely Corrosive.
    - Moderately Corrosive
    - Lightly Corrosive
  - Steel Corrosion
  - Considerations for Steel Corrosion Control
  - Aluminum Corrosion
  - Ductile Iron Corrosion
- Flow Abrasion Environment
- Flow Abrasion Environment Categories
  - Level 1 (Non-Abrasive)
  - Level 2 (Mildly Abrasive)
  - Level 3 (Moderately Abrasive)
  - Level 4 (Severely Abrasive)
- Cost Considerations
- Service Life



# CHAPTER 4



## Chapter 4 – Structural Design

Chapter 4 provides basic design concepts, load considerations, and other information relative to rigid and flexible pipe design, as well as specific design requirements for individual pipe material types.



# CHAPTER 5



## Chapter 5 – Installation and Acceptance Testing

Installation is the placement of new pipes elevated, within, beneath, or adjacent to a new or existing embankment or floodwall.

Installation and backfill as well as the acceptance testing and inspection once the pipe is installed.

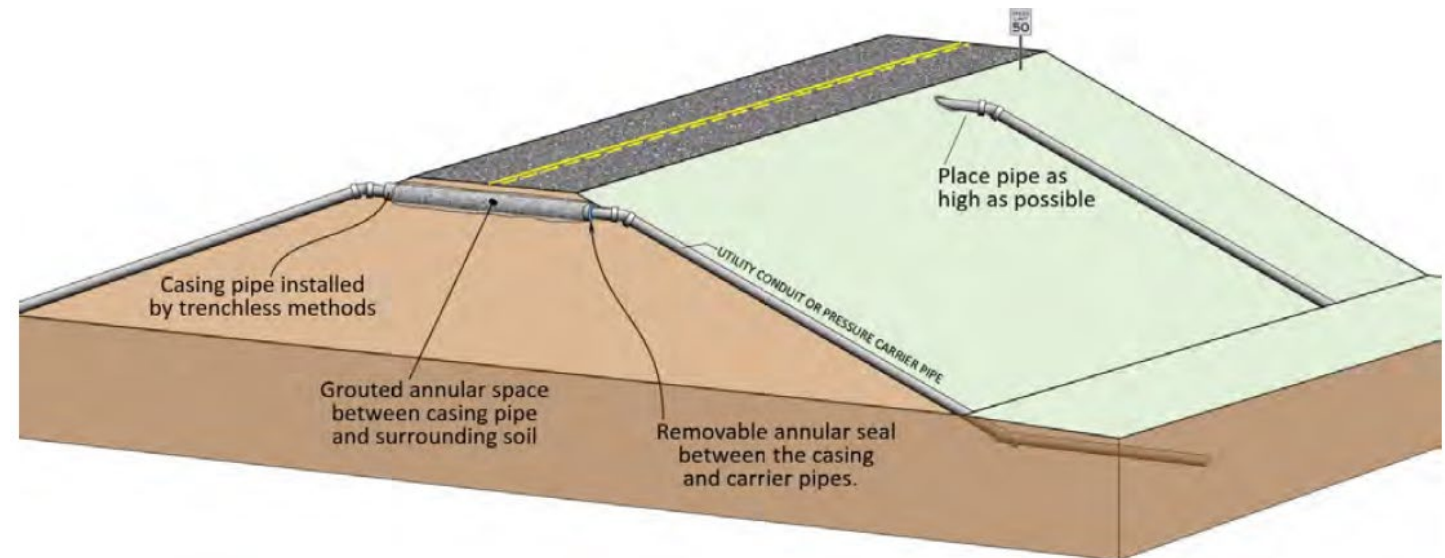
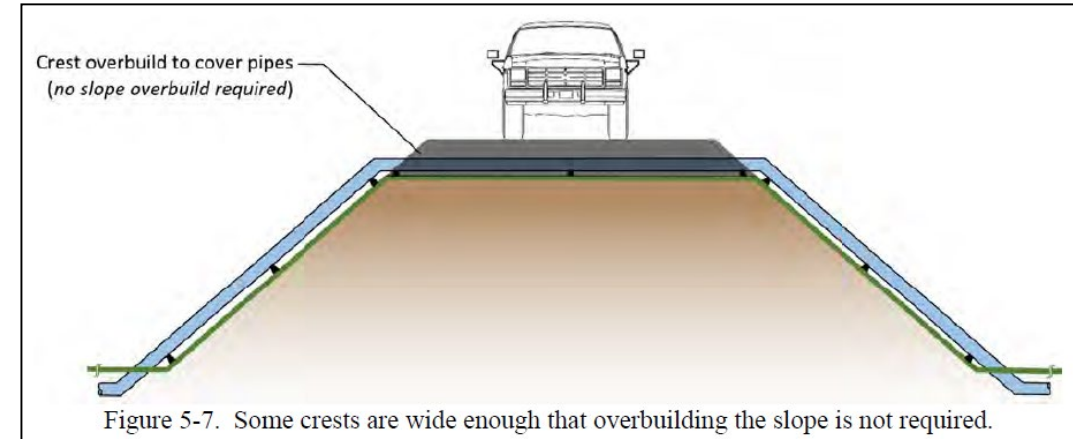
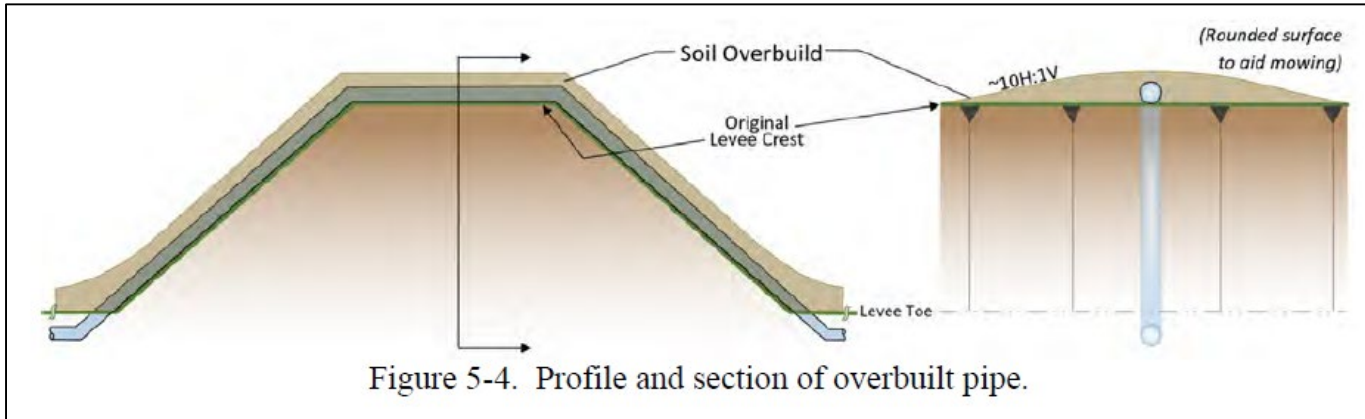
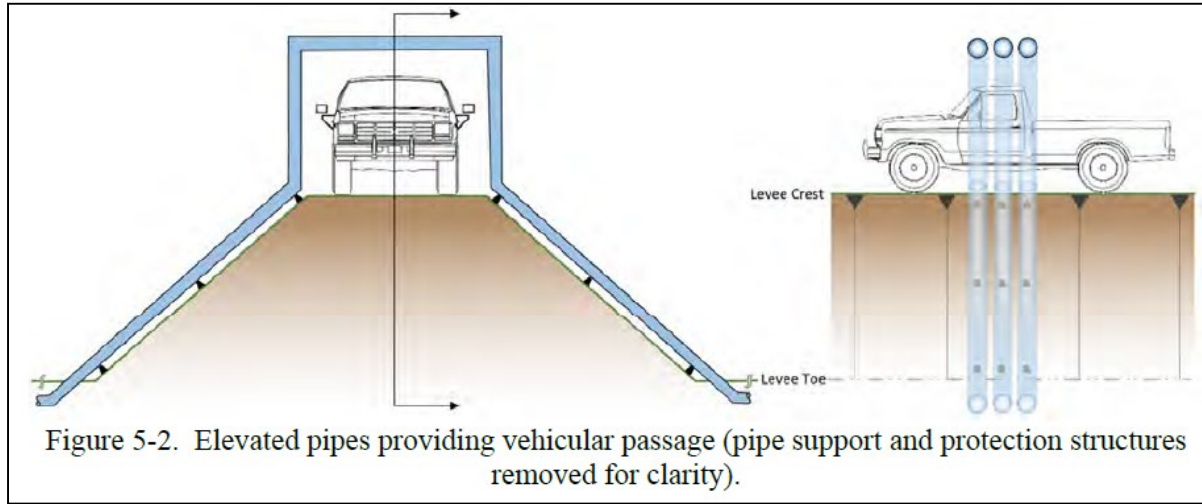

Figure 5-1. Example of allowable, non-essential pipe crossing beneath a highway.





# EXAMPLES — ELEVATED - PASSABLE – RAISED OR OVERBUILT



# EXAMPLES – ELEVATED OR NON-PASSABLE

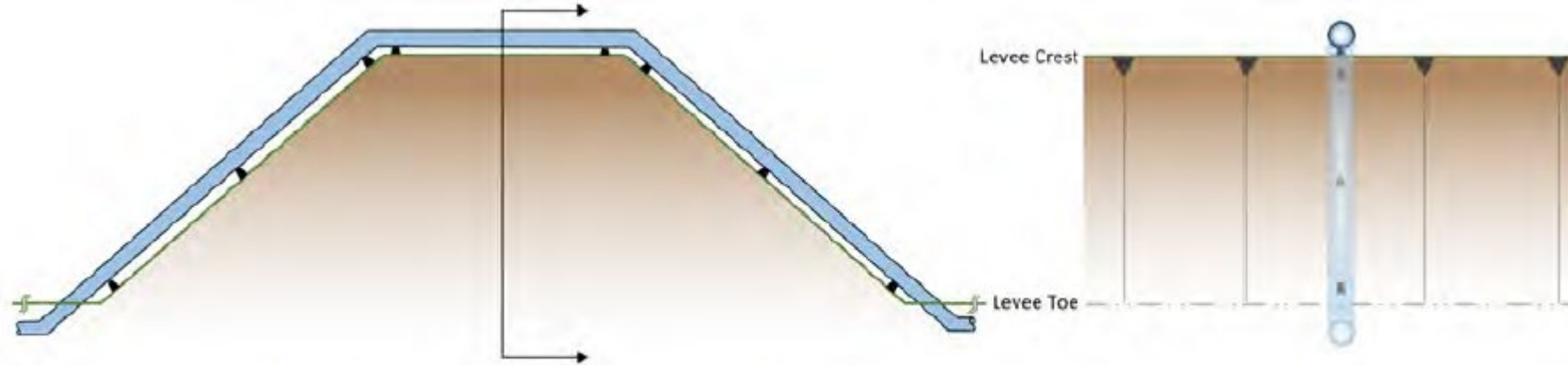
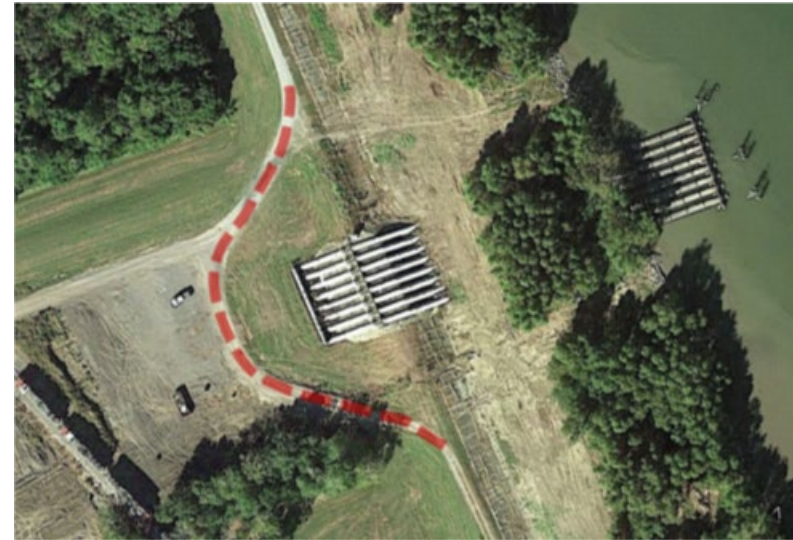

Figure 5-8. Elevated non-passable pipes prevent vehicular crossing.



# EXAMPLES – WITHIN - THROUGH

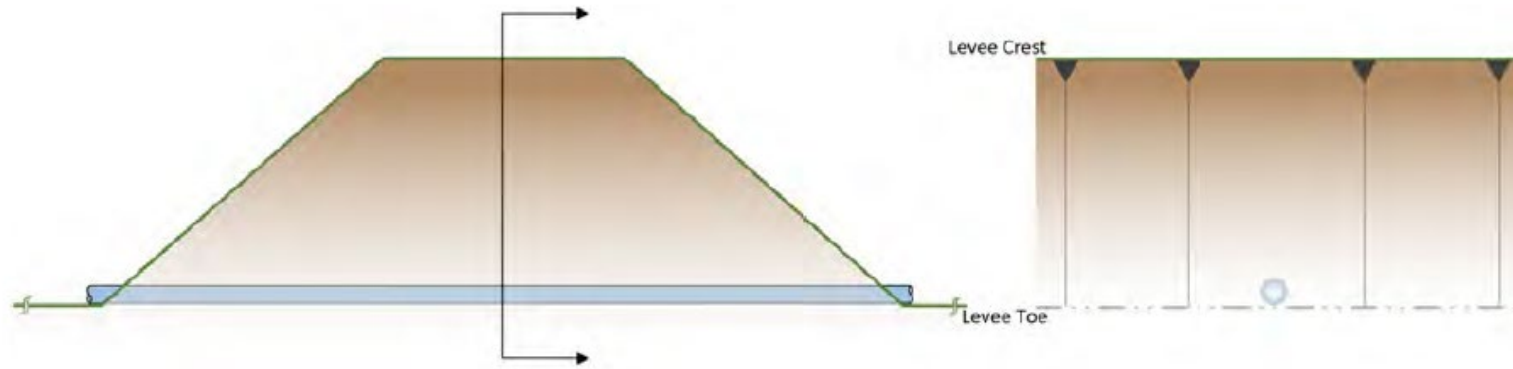
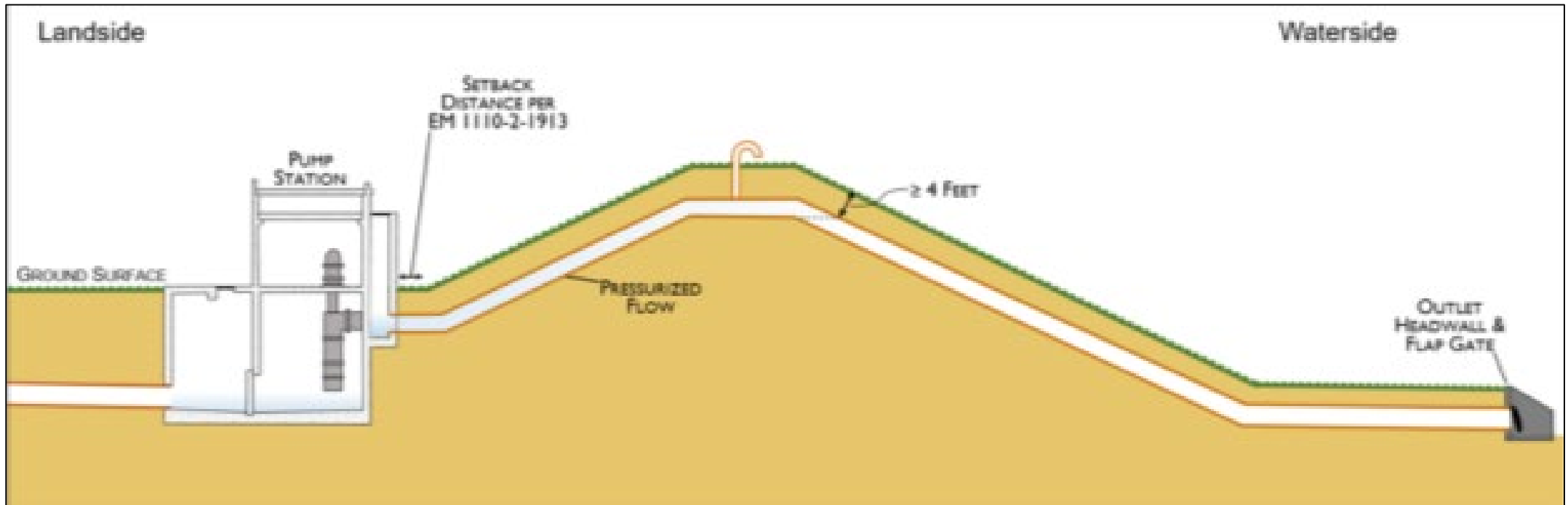

Figure 5-12. Pipe “through” a levee embankment.



# MITIGATION OF SEEPAGE RISK FOR – WITHIN – THROUGH EMBANKMENT – NEW PIPE INSTALLATION

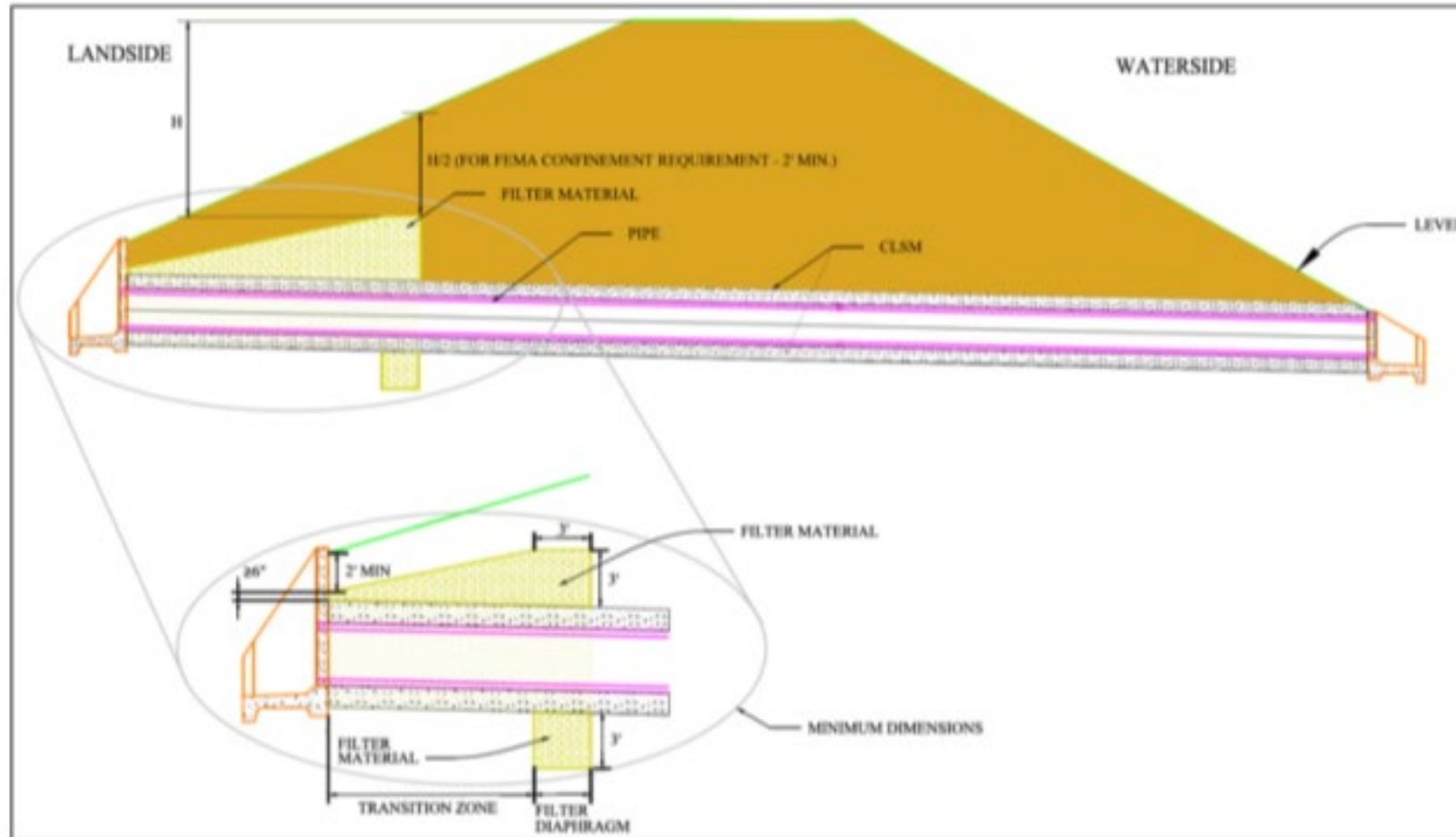

Figure 5-26. Elevation view of pipe and landside internal seepage filter.

# MITIGATION OF SEEPAGE ISSUES FOR – WITHIN – THROUGH EMBANKMENT – EXISTING PIPES

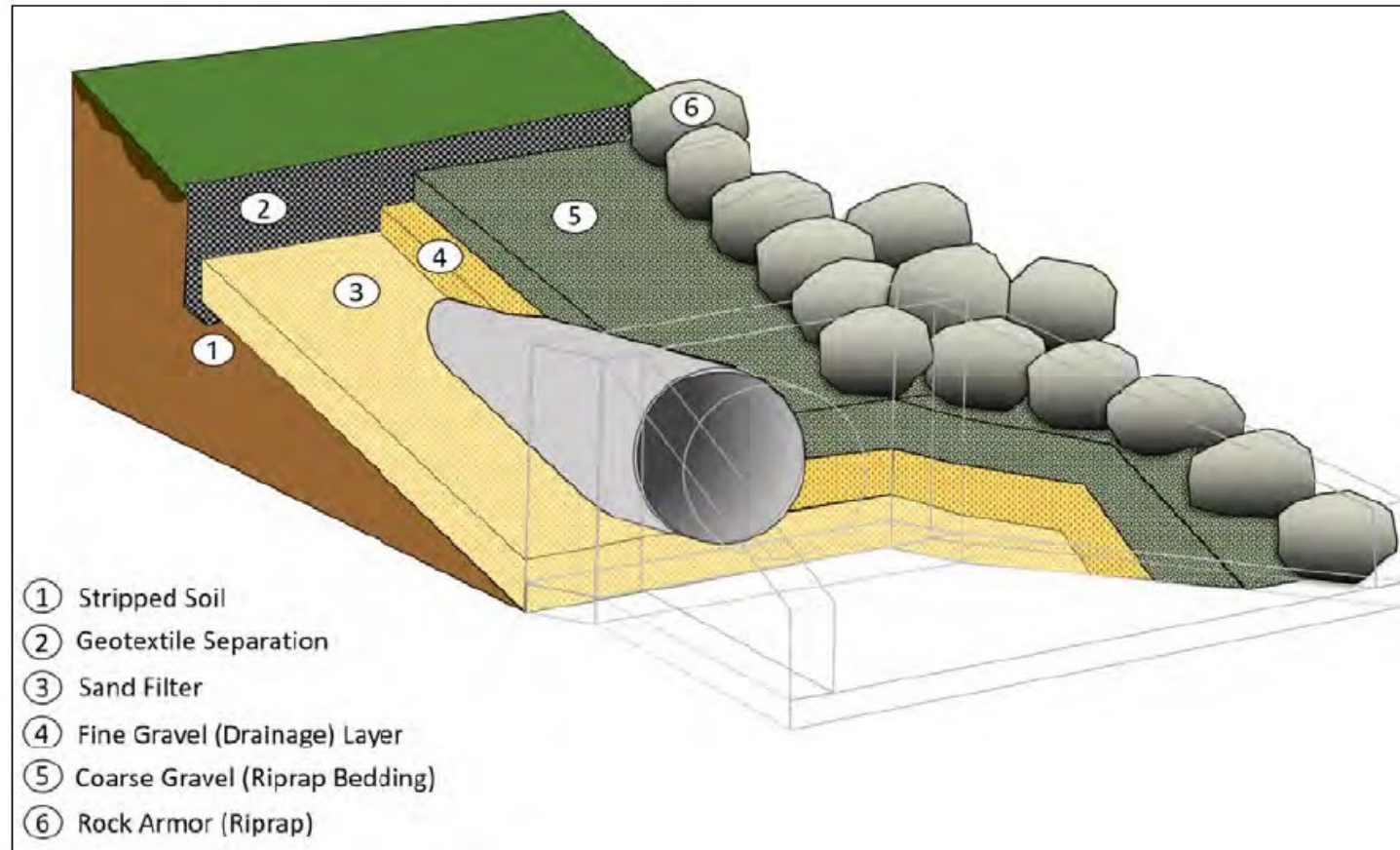

Figure 5-31. Details of External Seepage Filter (with or without a headwall).



# EXAMPLES - BENEATH



Installations can be in the foundation using

1. trenched
2. trenchless methods

# EXAMPLES – ADJACENT TO EMBANKMENTS OR FLOODWALLS



# EXAMPLES – ELEVATED OR WITHIN – THROUGH A FLOODWALL OR CLOSURE SILL

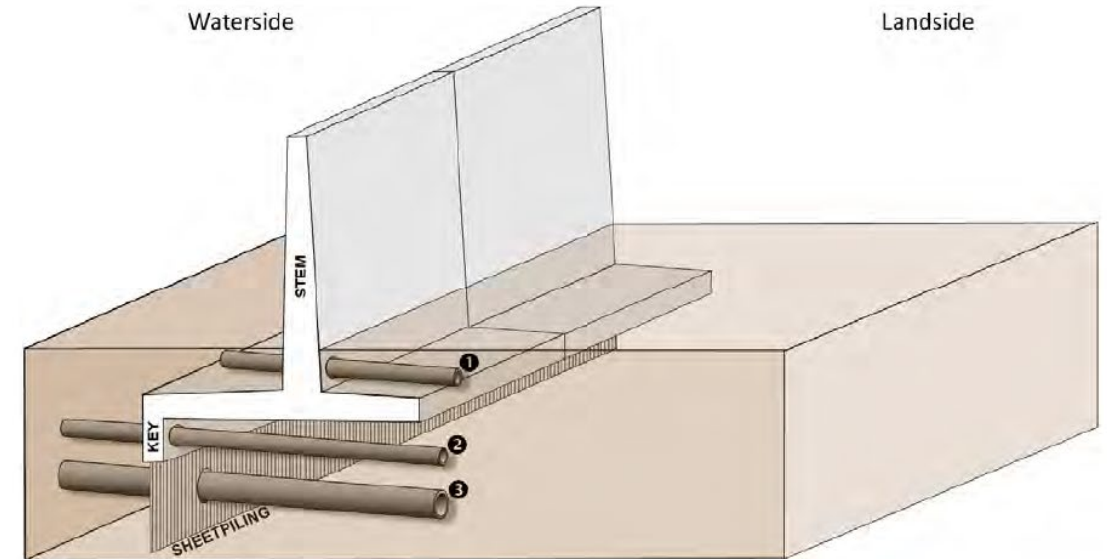

Figure 5-15. Potential pipe penetration locations.



# BACKFILL



**CONTROLLED LOW STRENGTH MATERIAL – CLSM  
EASY FOR THIS MATERIAL TO FILL THE HAUNCH AREA**

**SOIL – DIFFICULT FOR SOIL TO ENSURE THAT COMPACTION OF THE SOIL  
TAKES PLACE IN THE HAUNCH AREA.**





# PIPE JOINT TYPES



## ACCEPTANCE TESTING AND INSPECTION



# CHAPTER 6



## Chapter 6 – Inspections, Condition Assessments, and Prioritized Mitigation Plans

Chapter 6 includes information on how levee systems and their drainage pipes are inspected to determine potential failures.

This chapter outlines the limits, methods, requirements, documentation, and frequency of levee inspections.

Information regarding Prioritized Mitigation Plans is also included in this chapter.





# INSPECTION LIMITS



Landside

Waterside

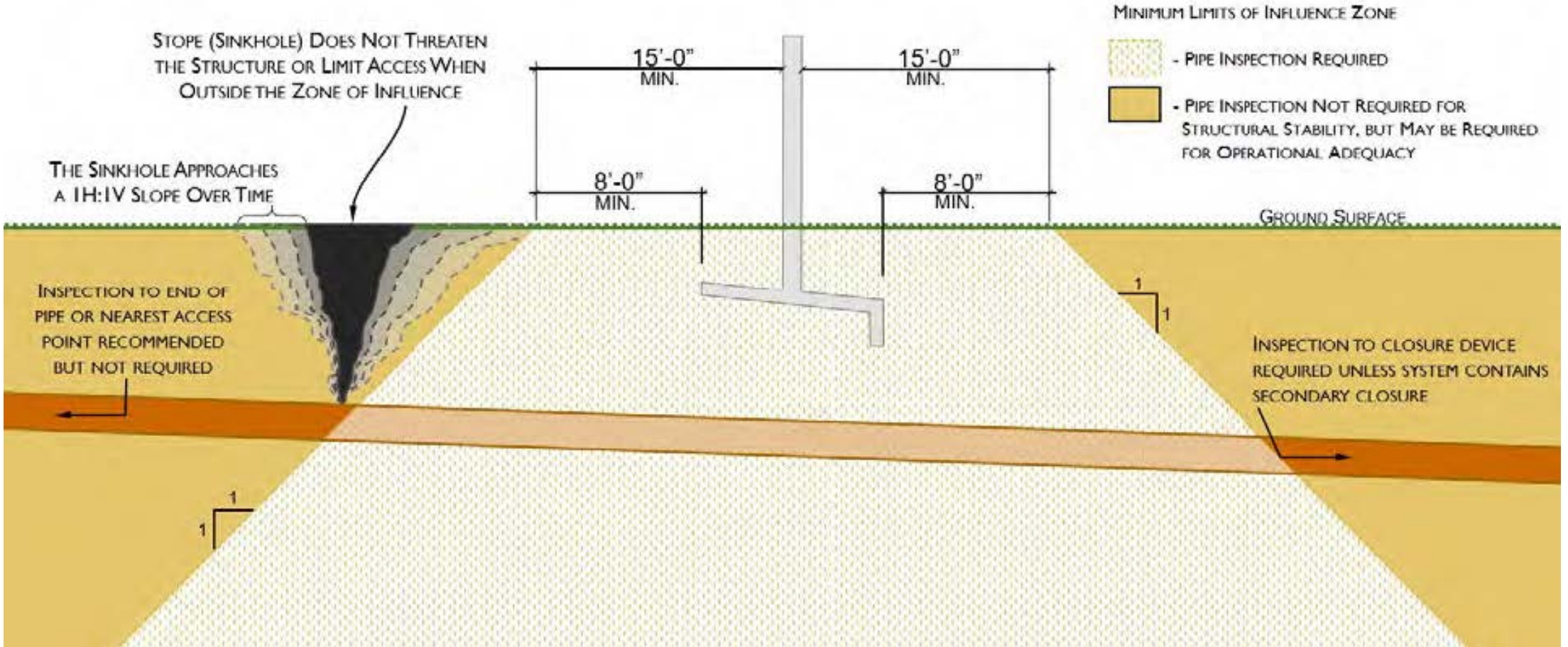

# INSPECTION LIMITS



## MINIMUM LIMITS OF INFLUENCE ZONE



- PIPE INSPECTION REQUIRED



- PIPE INSPECTION NOT REQUIRED FOR STRUCTURAL STABILITY, BUT MAY BE REQUIRED FOR OPERATIONAL ADEQUACY

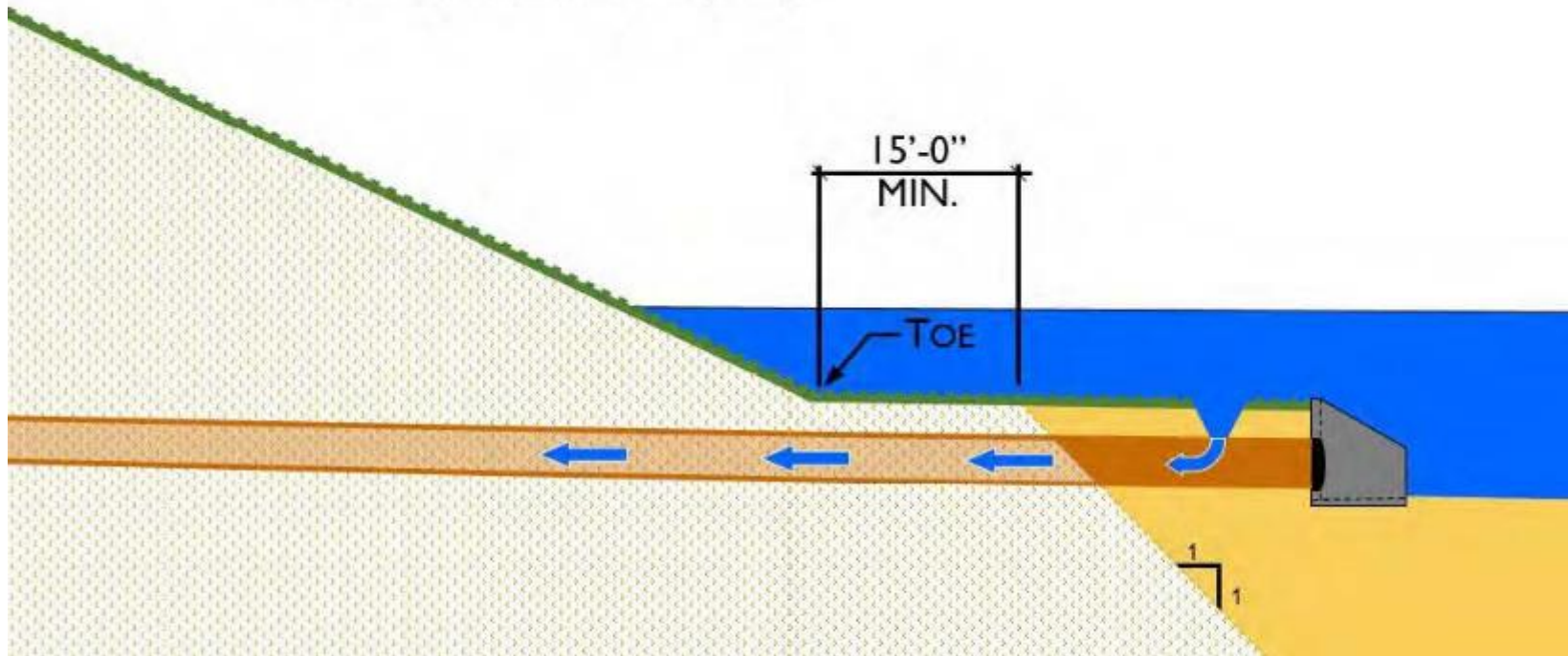



# PIPES THROUGH OR BENEATH A LEVEE EMBANKMENT

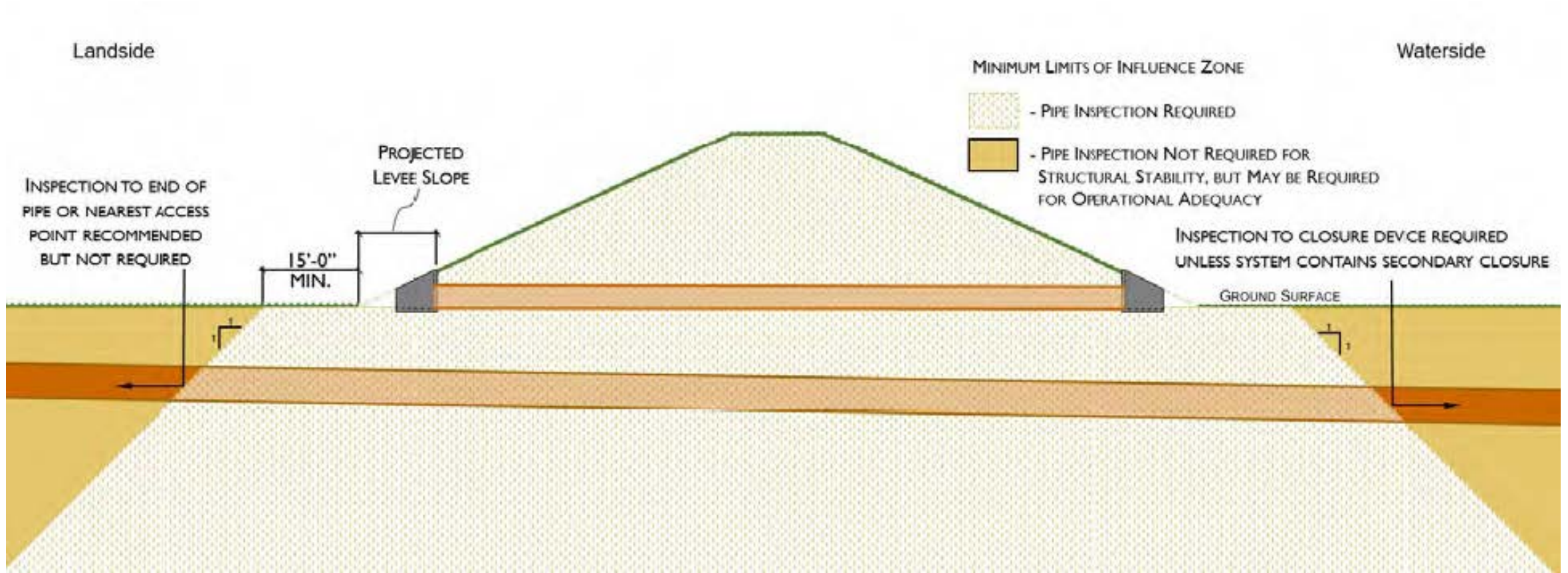

# PIPES BENEATH FLOODWALLS

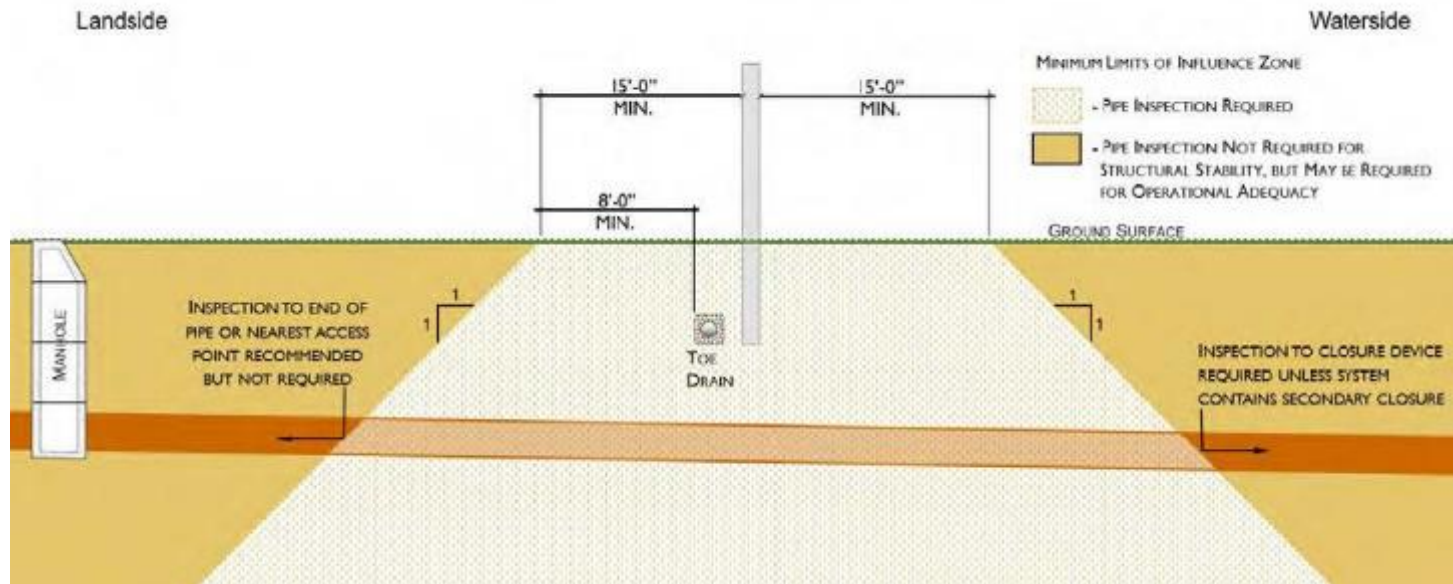
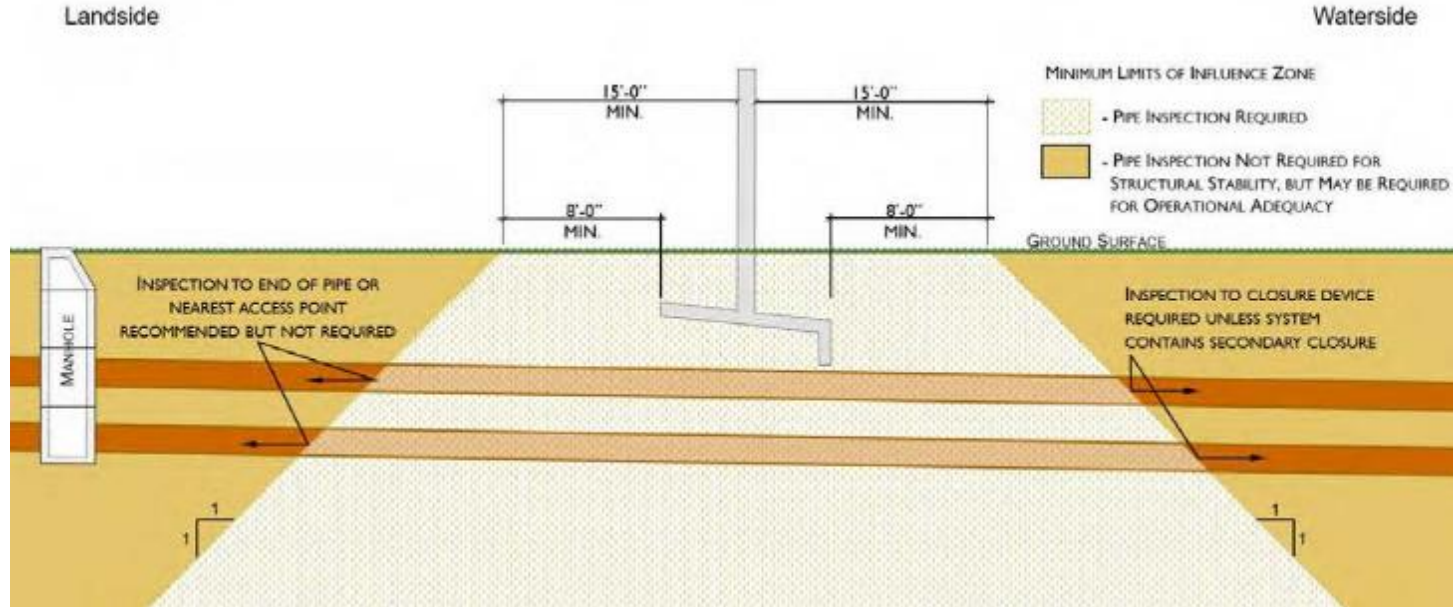

# PIPES ADJACENT TO THE LEVEE EMBANKMENT OR FLOODWALL – DO NOT CROSS

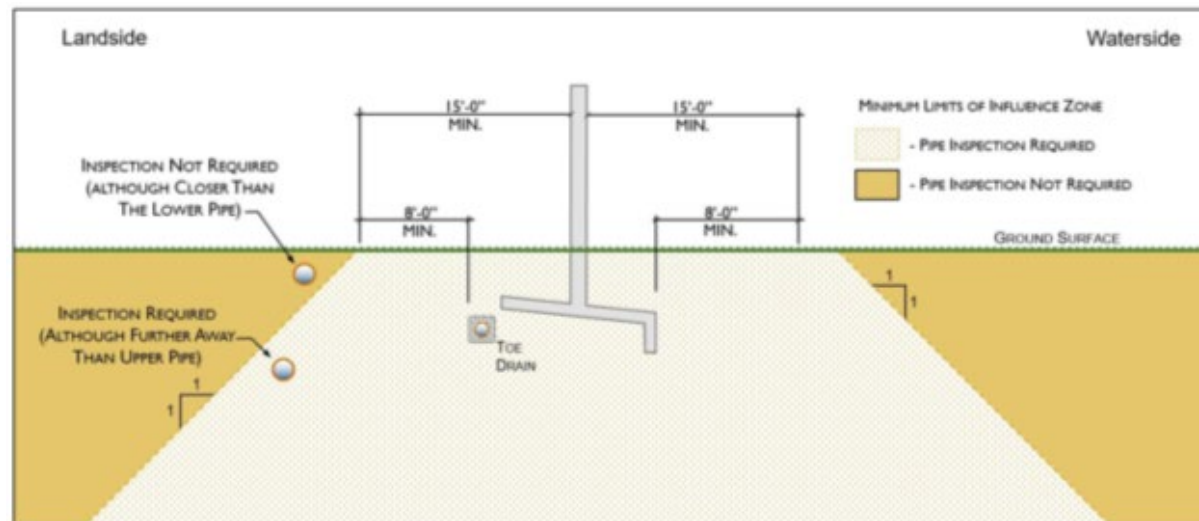
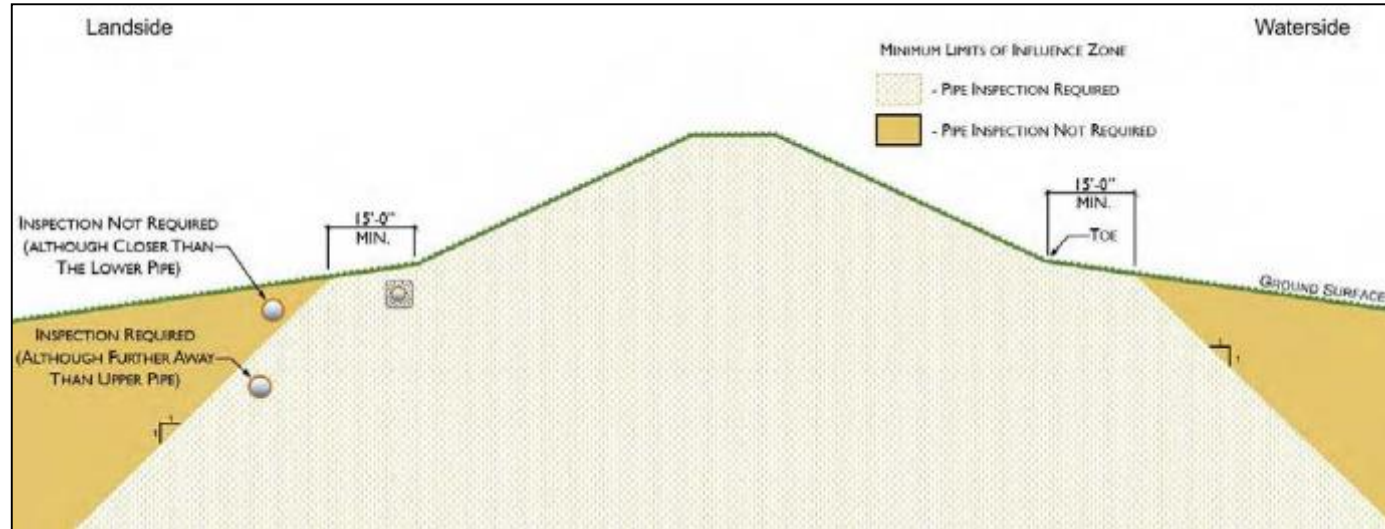
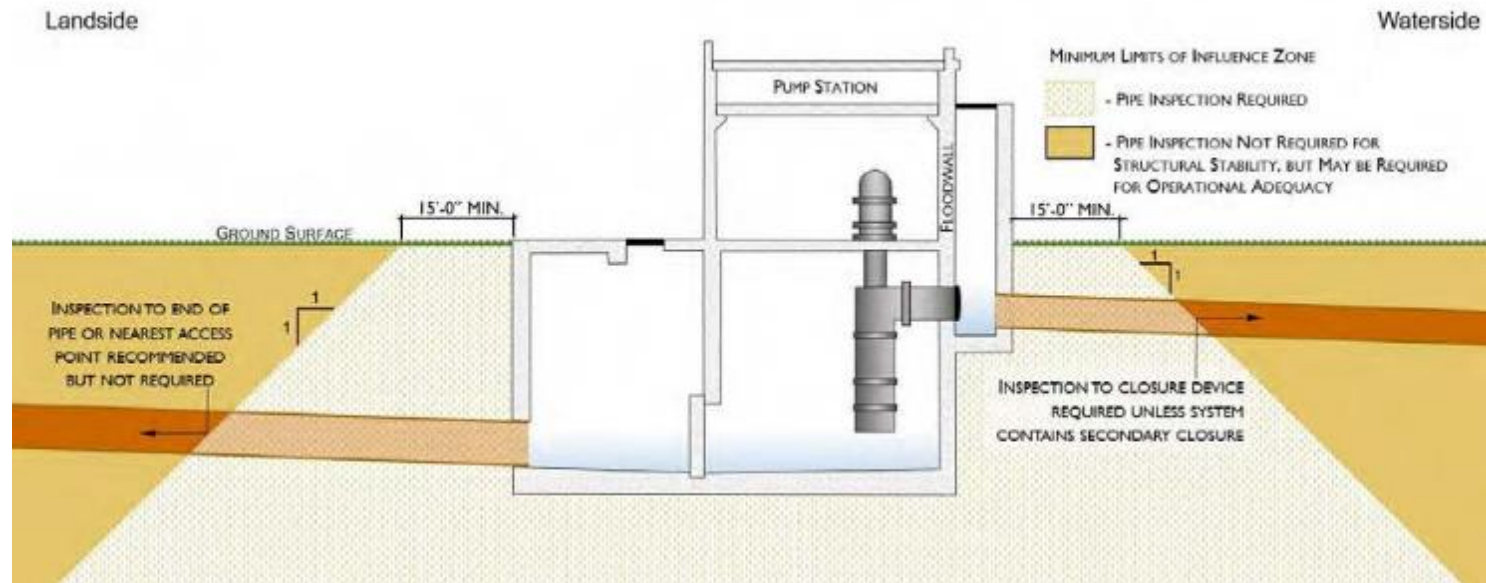
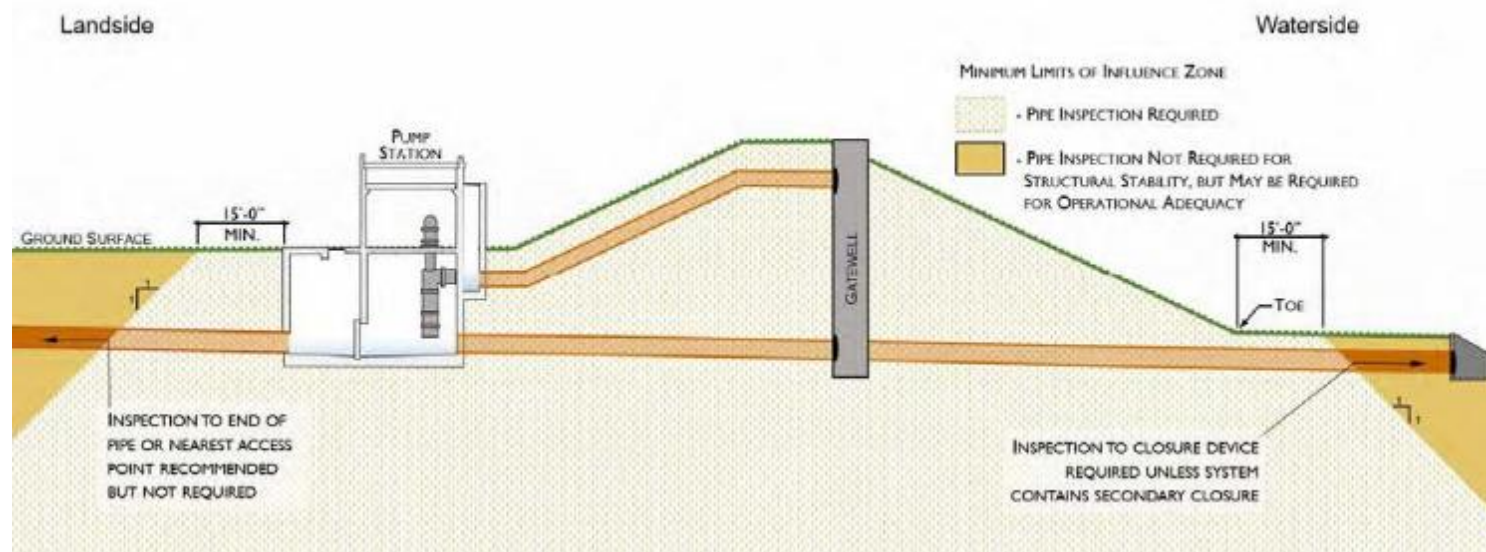

Figure 6-8. Gravity pipes adjacent to a floodwall (T-wall).

# DISCHARGE PIPES FROM PUMP STATIONS







# INSPECTION METHODS – WALK-THROUGH



Pipes less than 48 inches in diameter are typically considered too confined for a “walk-through” inspection and are therefore most often inspected using remote cameras or another comparable methods.

Pipes larger than 48 inches in diameter are easier for man-entry but other factors, such as air quality, and safety due to the condition of the deteriorated pipe that may necessitate or provide a preference for remote cameras.

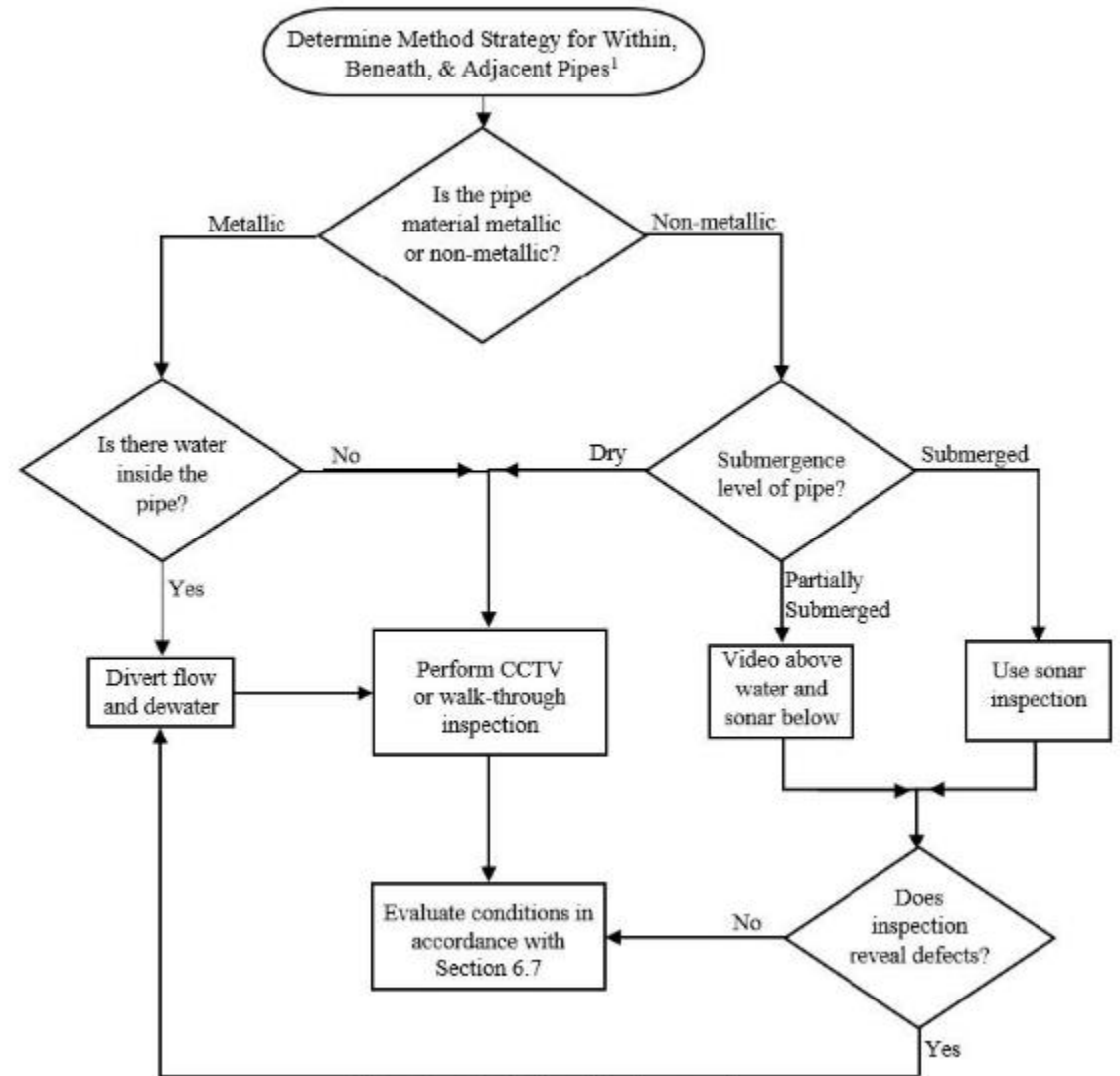

Note 1: Excluding third-party pipes



# INSPECTION METHODS - REMOTE



## CCTV

Pipes with dry or nearly dry interiors can be remotely inspected using CCTV cameras mounted on tracked or wheeled vehicles. Push-type CCTV cameras can also be used to remotely inspect sloped or vertical pipes when access will not allow tracked or wheeled CCTV equipment.

## CCTV and Sonar Hybrid

Partially-submerged pipes that cannot be dewatered are inspected using CCTV inspection above water and sonar inspection below water. When sonar inspection of a submerged pipe indicates that the pipe cross-sectional profile deviates from the as-built condition, the pipe must be dewatered and CCTV inspected.

## Sonar

Sonar is the preferred method for inspecting fully submerged non-metallic pipe when it is not practical to dewater the pipe. However, the quality of the visual record obtained by sonar is less detailed than CCTV.



# WALK-THROUGH REQUIREMENTS



Inspectors must be trained and certified by the NASSCO PACP, or an organization with equivalent standards.

Any pipe with debris, sediment, or other obstruction that inhibits the inspection of the pipe must be cleaned prior to inspection (reference Chapter 7).

Equipment and Tools



# REMOTE REQUIREMENTS



Individuals operating the remote inspection equipment must be trained and certified by the NASSCO PACP, or an organization with equivalent standards. A minimum of one year of experience with pipe inspections using the NASSCO's PACP or an equivalent industry standard is required.

Debris, obstructions, and sediment must be cleaned to provide an unobstructed view of the pipe's interior before video or other remote inspections are conducted.

Equipment and Tools



# INSPECTION DOCUMENTATION



Pipe inspections must be documented either using an inspection form during a walk-through inspection similar to the one shown to the right or a digital program that records the pipe condition during a remote inspection.

For both walkthrough and remote inspections, PACP (or equivalent) ratings must be used to rate the defects of the pipe.

SEGMENT/SYSTEM NAME:						
Inspected by (Name, Certification):						
Description:						
Station:				Date of Inspection:		
Type of Pipe:		Segment length (e.g. from inside wall of adj. manholes):		Pipe Diameter:		
Inlet Coordinates:			Outlet Coordinates:		Accuracy:	
Inspected via:						
Sketch (Path of Inspection, approx. Location of defect, location of pipe in relation to river portion of pipe under levee, etc.)						
Deficiency Details	PACP Defect Code	Location (ft.):	Time Stamp	Comments	Photo	Clock Position
Results Summary:						
Rating:						



# CONDITION ASSESSMENT



Table 6-1  
PACP Structural defect rating correlation to USACE pipe rating

PACP Structural Defect Grade Correlation To Required Action	NASSCO PACP Defect Grade for Dams and Levees	Required Action
<ul style="list-style-type: none"> <li>- Any crack hinge code</li> <li>- Any fracture, broken, or hole code</li> <li>- Collapse</li> <li>- Any flexible deformation &gt; 10%</li> <li>- Any brick deformation ≥ 10%</li> <li>- Any rigid deformation Code</li> <li>- Any joint offset, separated, or angular code</li> <li>- Dropped invert</li> </ul>	4 or 5	Mitigate
<ul style="list-style-type: none"> <li>- Any weld failure code</li> <li>- Any point repair defective code</li> <li>- Missing brick</li> <li>- Any surface damage reinforcement code</li> <li>- Missing mortar medium and large</li> <li>- Surface damage missing wall</li> <li>- Surface damage corrosion (without further inspection or section loss ≥ 25%)<sup>2</sup></li> </ul>		
<ul style="list-style-type: none"> <li>- Crack longitudinal, multiple, or spiral</li> <li>- Any flexible deformation ≤ 10%</li> <li>- Any brick deformation &lt; 10%</li> <li>- Displaced brick</li> <li>- Surface damage corrosion (with inspection and section loss &lt; 25%)<sup>2</sup></li> </ul>	3	Monitor
<ul style="list-style-type: none"> <li>- Surface damage surface <b>spalling</b></li> <li>- Any point repair code (non-defective)</li> <li>- Any surface damage aggregate code</li> <li>- Missing mortar small</li> <li>- Any lining feature code</li> </ul>		
All other codes	1 or 2	Continue Inspection Frequency

Table 6-2  
PACP O&M defect rating correlation to USACE pipe rating

PACP O&M Defect Grade Correlation To Required Action	NASSCO PACP Defect Grade for Dams and Levees	Required Action
<ul style="list-style-type: none"> <li>- Any deposits code ≥ 25% blockage</li> <li>- Any roots medium or ball code</li> <li>- Any infiltration runner or gusher code</li> </ul>	4 or 5	Maintenance & Repair
<ul style="list-style-type: none"> <li>- Any obstruction code ≥ 25% blockage</li> <li>- Any intruding seal code ≥ 25%</li> <li>- Any tap defective code</li> </ul>		
<ul style="list-style-type: none"> <li>- Any roots tap code</li> <li>- Any obstruction code 15% - 20% blockage</li> <li>- Any intruding seal code 15% - 20% blockage</li> </ul>	3	Monitor
<ul style="list-style-type: none"> <li>- Any tap intruding code</li> <li>- Any deposits code 15% - 20% blockage</li> <li>- Any infiltration dripper code</li> </ul>		
All other codes	1 or 2	Continue Inspection Frequency



# PRIORITIZED MITIGATION PLAN



USACE and levee sponsors should work together to develop and continuously update a planned approach to manage all levee-related risk, including pipes.

Typically, the risk management strategy for pipe mitigation is initially limited to a pipe-focused prioritization plan that would not consider risk from any other sources. This prioritized pipe list can then be used to help determine the order of overall management activities for the levee.

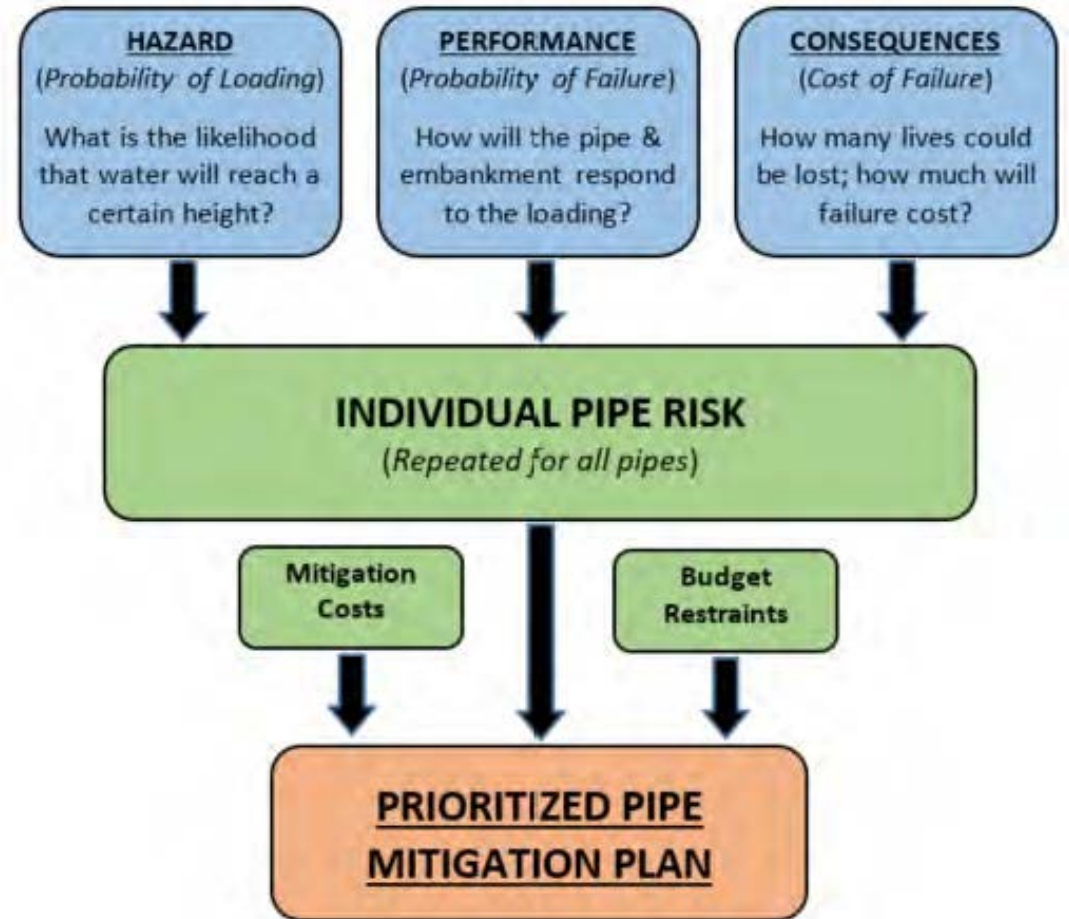



# INSPECTION FREQUENCY

Drainage pipes must be inspected at recurring intervals; the limits of those inspections for levees are covered in Section 6.4 or at the first part of my presentation on Chapter 6. The flow chart to the right outlines how the frequency of pipe inspections is determined.

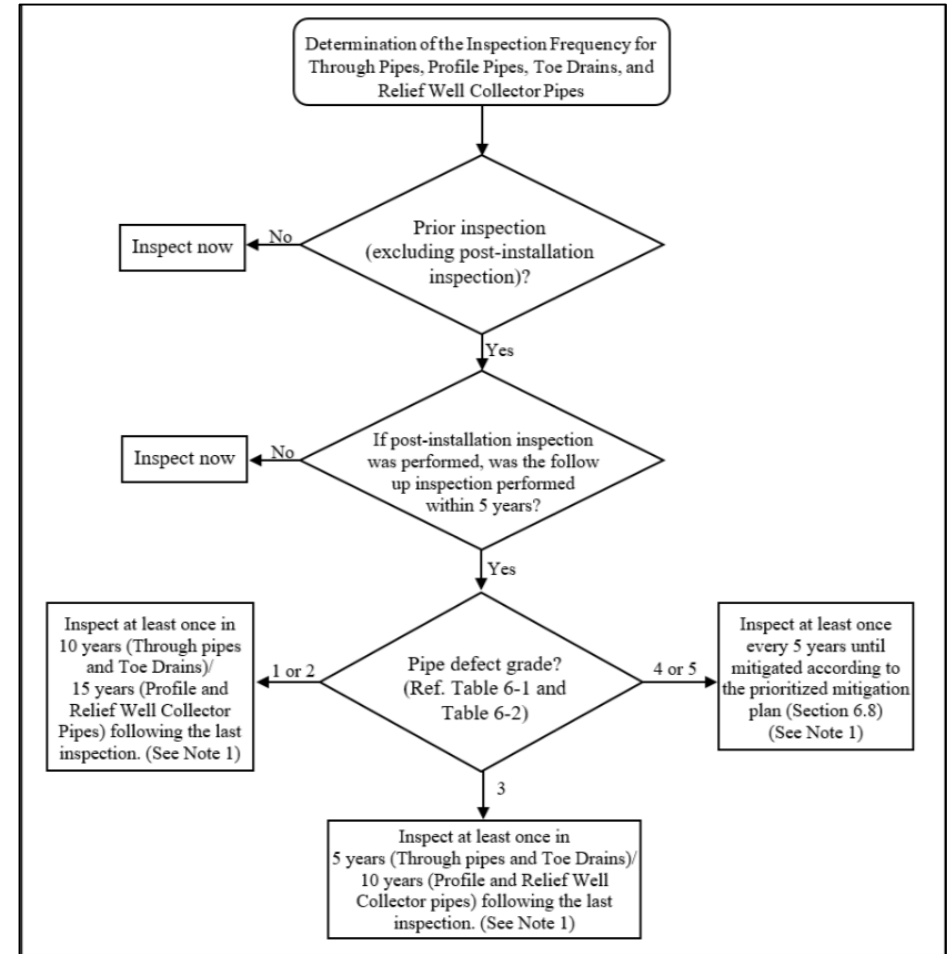





# CHAPTER 7

## Maintenance, Repair, and Rehabilitation





# MAINTENANCE



Maintenance of pipes and their appurtenances (e.g., flap gates, slide gates, valves) should typically be routine and planned in accordance with the project's operation and maintenance manual.

Cleaning, root removal, and ice removal are common maintenance items that should be preformed regularly.



# CLEANING



Non-aggressive cleaning removes loose debris, root intrusion, ice accumulation, or biofouling, all of which reduce a pipe's hydraulic capacity and can inhibit appurtenance operation.

Careful debris cleaning may be accomplished using small excavators at the pipe inlet/outlet as well as high-pressure flushing, root augers, and ice melting tools within the pipe.

Hydro-jet nozzles, like the one shown below, can remove sediment, debris, and deposits (e.g., grease or pipe scale) from a pipe's interior.

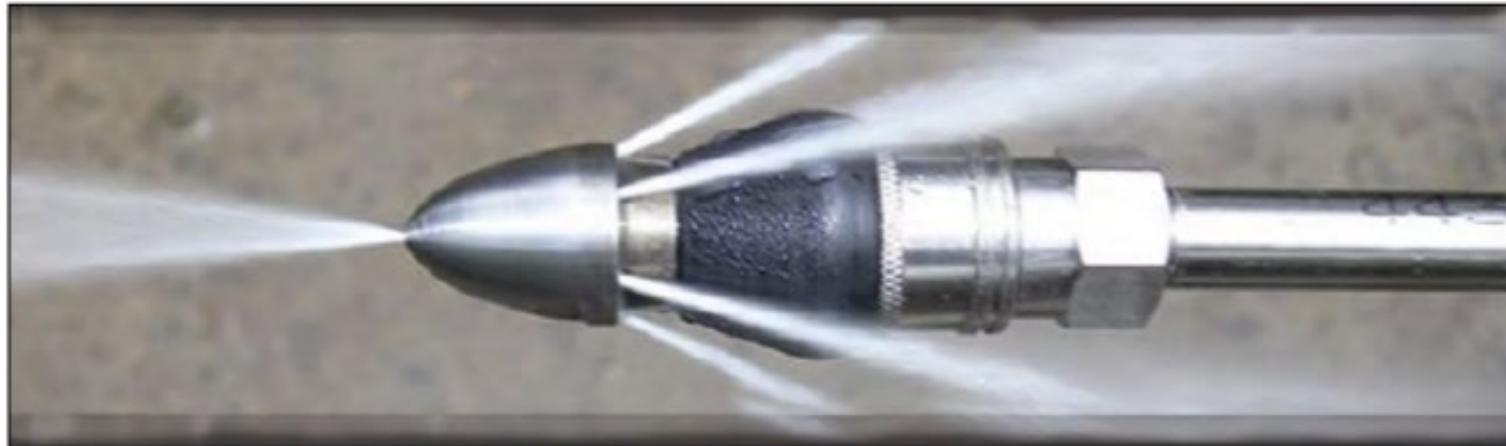

(From Drains CO, UK, 2019)



# ROOT REMOVAL USING AUGERS



The use of mechanical augers within a pipe is the best way to remove roots.

However, this is typically only a temporary measure since their presence indicates cracks or openings in the pipe's joints or connections to taps, which may also have allowed the movement of soil into the pipe (PFM-3).

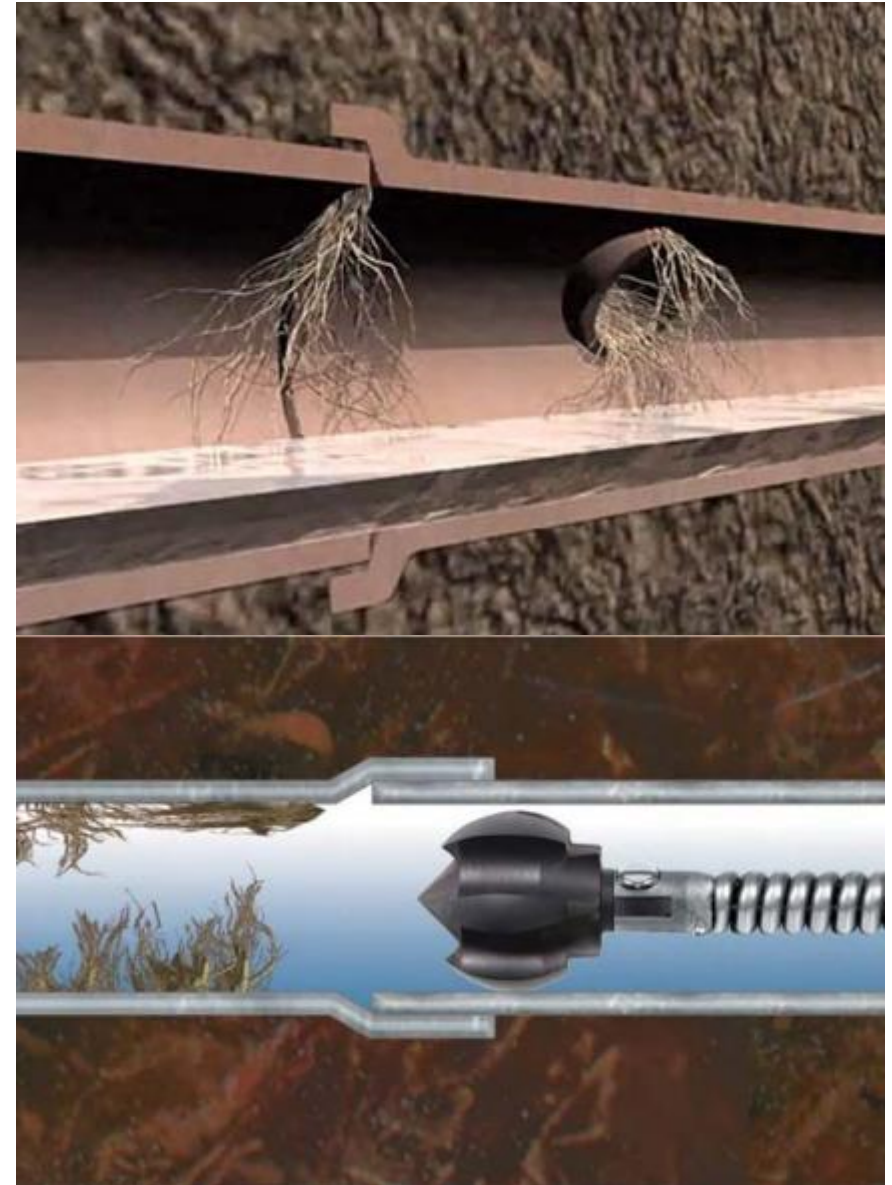



# ICE REMOVAL

Steam, hot water flushing, and electric heaters can be used to remove ice from pipes and gates in cold weather environments.

Bubbler systems can help preemptively prevent water from freezing within pipes or gatewell structures.

Ice buildup reduces or completely eliminates a pipe's hydraulic capacity (PFM-5) and can prevent gate operations (PFM-7).





# REPAIR



Repairs to existing pipes are performed when a pipe inspection and condition assessment reveal an issue that can adversely impact the integrity of the embankment or floodwall.

Repair recommendations are included in Section 7.4 for the following pipe materials:

- Reinforced Concrete Pipe (RCP)
- Concrete Pressure Pipe (CPP)
- Vitrified Clay Pipe (VCP)
- Corrugated Steel Pipe (CSP)
- Corrugated Aluminum Pipe (CAP)
- Welded Seam Steel Pipe (WSSP)
- Ductile Iron Pipe (DIP)
- Thermoplastic – Polyvinyl Chloride (PVC)
- High-Density Polyethylene (HDPE)
- Polypropylene (PP)
- Fiberglass Reinforced Pipe (FRP)



# REHABILITATION



Rehabilitation of a pipe is performed when the pipe is systemically deteriorated and where it is supported by the condition assessment process.

Rehabilitation is typically less expensive than pipe replacement since it does not involve disturbing the existing embankment; it also restores the hydraulic capacity to near its original condition.

The selection and design of an appropriate pipe rehabilitation method is dependent on existing pipe condition, its hydraulic capacity, and the purpose of the pipe within an embankment.

Pipe rehabilitation is typically conducted using a trenchless method involving the use of internal liners such as slip lining, spray-in-place (SIPP) liners, close-fit liners, and pipe bursting and splitting. However, not all rehabilitation methods are acceptable by USACE for use in pipes that penetrate embankments.



# SLIP LINING



Slip lining is the most common type of trenchless rehabilitation and is acceptable for use where continuous or segmental pipe can be inserted by either pulling or pushing it into the host pipe and the minimum clearances for grouting the annular space between the host and liner pipe can be maintained.

Slip lining can be used in cases where the host pipe is deformed, badly damaged from corrosion, or has offset joints or cracks allowing infiltration/exfiltration. However, if there are significant distortions of the host pipe, a much smaller-diameter liner may be needed that would not provide adequate discharge capacity; open cut and replacement of the pipe is required in such cases.

USACE-approved materials for slip lining are spiral wound PVC, solid-wall HDPE, and FRP.

Design requirements, installation instructions, and grouting techniques for each method of installation are included under Section 7.5.2.





# OTHER REHABILITATION METHODS



Liner methods that do not allow space for pressurized grouting between the deteriorated host pipe and new liner are not permitted for gravity drains in USACE levees.

The inability to grout the annular space means that any voids created by the loss of embankment soil through pipe defects would not be filled, promoting PFM-1.

However, if the host pipe has no penetrating deterioration and no visible soil at the joints, and deflection is less than five percent (reference Table 4-1), SIPP and close-fit liners (e.g., cured-in-place pipe liners [CIPP]) may be approved on a case by case basis by the respective USACE District.

Spray-in-place liner and close-fit liner methods are discussed under Section 7.5.4.



# CHAPTER 8



## Chapter 8 – Removal and Decommissioning

Chapter 8 provides information on and general procedures for removal and in-place decommissioning of existing pipes, including methods to reduce the probability of pipe-related PFM's.



(Courtesy of USACE Louisville District)

Figure 8-1. Sinkhole in levee due to collapsed pipes.



(Courtesy of USACE Louisville District)

Figure 8-2. Removal and replacement of collapsed pipes.



# CHAPTER 8



## Removal and Decommissioning Limits

The removal or decommissioning limits for a pipe are the same as the influence zone limits referenced in Chapter 6.



(Courtesy of Mobile Concrete and Grout of Alaska)

Figure 8-3. Typical infill and vent ports through a temporary bulkhead.



# CHAPTER 8



## Section 408 Considerations for Pipe Removal/Decommissioning

- The respective USACE District will review documentation related to proposed removal or decommissioning methods to determine if such actions are subject to 33 USC 408 and require approval.

## As-Built Documentation



# CHAPTER 9



## Chapter 9 – Associated Structures and Appurtenances for Levees

Associated structures (e.g., pump stations, gatewells, headwalls) are directly connected to the pipe and often provide man-entry access or control the entry and exit flow of water

Appurtenances are mechanical flow-controlling and closure devices (e.g., sluice gates, flap gates, pumps) typically found within an associated structures.



# CHAPTER 9



## Associated Structures – Pump Stations



(Courtesy of USACE Louisville District)  
Figure 9-2. Pump station at landside toe.



(Courtesy of USACE Louisville District)  
Figure 9-3. Pump station at levee centerline.

## Associated Structures – Gatewells

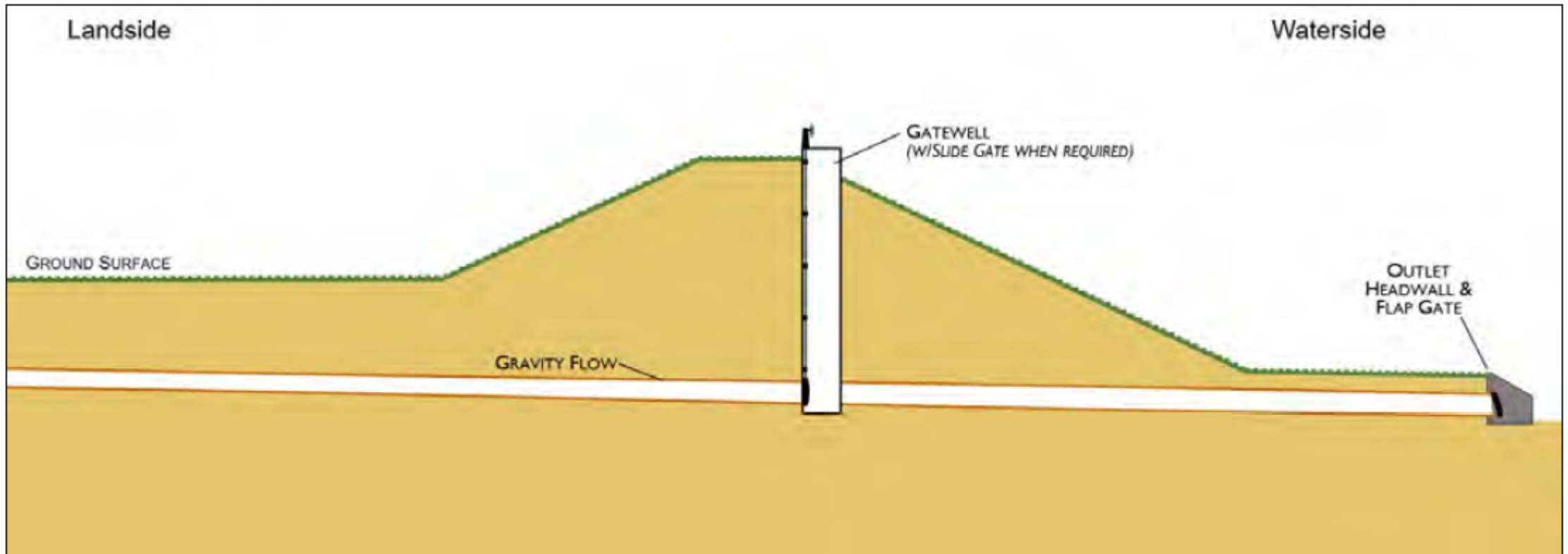

Figure 9-9. Cross-section of gatewell adjacent to waterside crest in levee embankment.





# CHAPTER 9



## Associated Structures – Catch Basins

Catch basins function by draining the nearby surface water into a pipe that transports the water out of the leveed area by gravity flow.

Catch basins are usually precast concrete structures and are required to be sealed to prevent soil infiltration. Additional information for catch basins can be found in EM 1110-2-2002.



(Courtesy of USACE Louisville District)

Figure 9-10. Typical catch basin at toe of levee.



# CHAPTER 9



## Associated Structures – Manholes



(Courtesy of USACE Louisville District)

Figure 9-11. Typical manhole with sluice gate.



# CHAPTER 9



## Associated Structures – Headwalls



(Courtesy of USACE Louisville District)

Figure 9-13. Typical flat headwall with flap gate.



(Courtesy of USACE Louisville District)

Figure 9-12. Typical headwall with wingwalls and flap gate.



# CHAPTER 9

## Appurtenances – Gates





# CHAPTER 9



## Appurtenances – Gates

Table 9-1

Closure type requirements for pipes

Flood Rise <sup>1</sup>	Pipe Diameter (inches)	Required Closure Configuration
Fast	< 36	(1) Passive
Fast	≥ 36	(1) Passive AND (1) Active
Slow	< 36	(1) Passive OR (1) Active
Slow	≥ 36	(1) Passive and (1) Active -OR- (2) Active

1. Fast flood rise refers to floods capable of rising to a flood stage with less than 12 hours prediction time.



# CHAPTER 9



## Appurtenances – Pumps



(Courtesy of USACE Louisville District)

Figure 9-25. Typical pump intake in pump station sump area.



(Courtesy of USACE Louisville District)

Figure 9-26. Underground pump station structure.



# CHAPTER 9



## Appurtenances – Air Vents and Siphon Breakers



(Courtesy of USACE Louisville District)  
Figure 9-27. Typical pump station air vents.



# CHAPTER 9



## Appurtenances – Valves on Pressurized Pipes

Valves are typically associated with third-party pipes carrying various types of fluids or gases.





# CHAPTER 9



Connections to Associated Structures covered in EM 2902 include:

- Non-Pressure and Low-Pressure Reinforced Concrete Pipe (RCP) to Associated Structure Connections
  - Cast-in-Place and Precast
  - Steel Rings
- Concrete Pressure Pipe (CPP) to Associated Structure Connections
- Vitrified Clay Pipe (VCP) to Associated Structure Connections
- Corrugated Steel Pipe (CSP) to Associated Structure Connections
- Welded Seam Steel Pipe (WSSP) to Associated Structure Connections

- Corrugated Aluminum Pipe to Associated Structure Connections
- Ductile Iron Pipe (DIP) to Associated Structure Connections
- Thermoplastic Pipe
  - Corrugated High Density Polyethylene (HDPE) Pipe to Associated Structure Connections
  - Solid-Wall High Density Polyethylene to Associated Structure Connections
  - Fiberglass Reinforced Pipe (FRP) to Associated Structure Connections



# CHAPTER 10



## Chapter 10 – Associated Structures and Appurtenances for Dams

Chapter 10 discusses the function, references relevant design guidance, and addresses concerns with a dam’s outlet works (to include the conduit and its associated structures and appurtenances (EM 1110-2-2400)).

An associated structure is a structure within the outlet works that is directly connected to the conduit, while an appurtenance is a device within or attached to an associated structure.

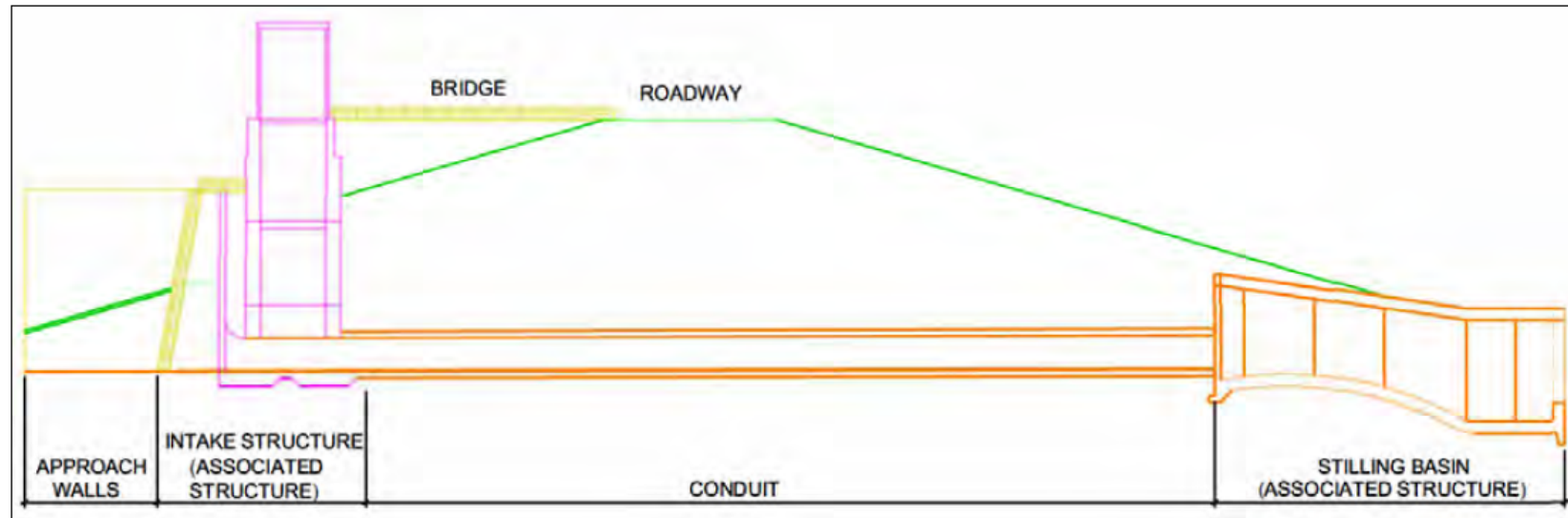

Figure 10-1. Typical configuration of a dam and outlet works.



**QUESTIONS?**