

# CHAPTER 10

## TELETYPEWRITER EQUIPMENT AND OPERATION

### BASIC TELETYPEWRITER CIRCUIT

To see how intelligence is sent by teletypewriter, let us first consider one of the simpler devices for electrical communications: the manual telegraph circuit. In this circuit, shown in figure 10-1, we have a telegraph key, a source of power (battery), a sounder, and a movable sounder armature. If the key is closed, current flows through the circuit and the armature is attracted to the sounder by magnetism. When the key is opened, the armature is retracted by a spring. With these two electrical conditions of the circuit—closed and open—it is possible, by means of a code, to transmit intelligence. These two conditions of the circuit may be thought of as MARKING and SPACING. Remember: Marking occurs when the circuit is closed and a current flows; spacing occurs when it is open and no current flows.

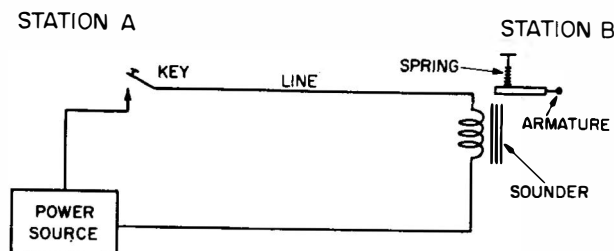
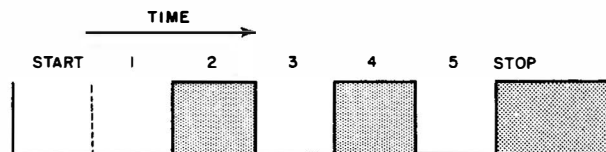

Figure 10-1.— Manual telegraph circuit.  
1.196

When a circuit operates on current and no-current basis, as in figure 10-1, it is called a NEUTRAL circuit. This type is generally used to operate teletypewriters, although the Navy's machines sometimes operate on a line condition called POLAR OPERATION. This refers to the system whereby marking signals are formed by current impulses of one polarity, and spacing signals by current impulses of equal magnitude but opposite polarity. The following discussion is based on neutral circuit operation.

### TELETYPEWRITER SIGNAL CODE

If a teletypewriter signal could be drawn on paper, it would resemble figure 10-2. This is the code combination for the letter R. Shaded areas show intervals during which the circuit is closed (marking), and the blank areas show the intervals during which the circuit is open (spacing). There are a total of seven units in the signal. Five of these are numbered, and are called INTELLIGENCE units. The first and last units of the signal are labeled START and STOP. They are named after their functions: the first starts the signal and the last stops it. These are a part of every teletypewriter code character; the START unit is always spacing and the STOP unit is always marking. This method of teletypewriter communication—the so-called START-STOP method—gets its name from these units.



1.197

Figure 10.2.— Mark and space signals in the teletypewriter character R.

The start-stop method keeps teletypewriter machines and signals in synchronization with each other. With this method the selecting mechanism in the receiving machine comes to a complete stop after each character.

Different characters are transmitted from the keyboard by an automatic process that selects various combinations of marking and spacing in the 5 intelligence units (fig. 10-3). When you come to tape reading, you will see that the mark and space units match the holes and blank spaces on the tape. This is because holes in the tape allow the transmitter distributor pins to rise,



when the start pulse is received, thus allowing the selector cam-clutch to rotate through 1 revolution. During this revolution, 5 selector levers in the selector unit are positioned by the operation or release (marking or spacing) of the selector magnet armature as determined by each intelligence pulse received. The time required to position each selector lever is approximately 20 percent of the time of 1 intelligence pulse, or 4.4 milliseconds. This time, again, is based on a teletypewriter running at 60 wpm. Cams on the selector cam-clutch are so located at the time between each selector lever operation is fixed at 22 milliseconds. During 4.4 milliseconds of the first pulse the first selector lever is positioned; during 4.4 milliseconds of the second pulse the second selector lever is positioned, and so forth, until all 5 selector levers are positioned (see fig. 10-6). These selector levers control the internal mechanism of the teletypewriter so as to select and at the proper time print the correct character.

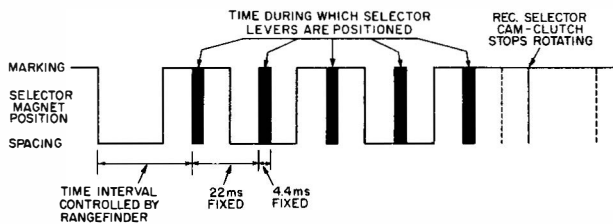

1.201

Figure 10-6.—Selecting intervals for letter Y.

### BAUDS AND WORDS-PER-MINUTE

Heretofore most discussions of teletypewriter speed have been in terms of how many words-per-minute are transmitted. Now a more technically accurate term "baud" is being used.

The baud is officially designated as the unit of modulation rate. One baud corresponds to a rate of 1 unit interval per second. Hence, to find the modulation rate of a signal in bauds, the figure 1 is divided by the time duration of the shortest unit interval present in the signal. For example, 22 milliseconds (.022) is the time interval of the shortest unit in the 7.42-unit code at 60 words-per-minute (wpm). To find the number of bauds corresponding to 60 wpm, we divide .022 into 1. Rounding off the results of our division, we arrive at the figure 45.5, which is the baud equivalent of 60 wpm.

At 100 wpm, the teletypewriter operating speed is increased, and the signal unit time interval is decreased. An operating speed of

100 wpm is 74.2 bauds, and a speed of 107 wpm is 75 bauds—the ultimate goal for Navy teletypewriter operation.

Conversion formulas for baud operations are as follows:

$$\text{Baud} = \frac{1}{\text{Unit interval}}$$

$$\text{WPM} = \frac{\text{Baud}}{\text{Unit code} \times 0.1}$$

### DISTORTION

An ideal teletypewriter circuit reproduces signals at the receiving end exactly as they are impressed at the sending end. Unfortunately, this seldom happens under actual operating conditions, for signal units have a way of lengthening and shortening as they travel along the circuit. This lengthening and shortening of marks and spaces occurring during transmission reduces the quality of the signal, and is called distortion.

Four fundamental types of distortion adversely affect fidelity of teletypewriter signals.

1. Bias distortion is the uniform lengthening or shortening of the mark or space elements, one at the expense of the other. This means that the total time for one mark and one space never changes; only the length of the mark or space element changes. If the mark is lengthened, the space is shortened by the amount the mark is lengthened. Bias distortion may be caused by maladjusted teletypewriter line relays, detuned receivers, or a drift in frequency of either the transmitter or receiver.

2. Fortuitous distortion is the random displacement, splitting, or breaking up of the mark and space elements. It is caused by crosstalk interference between circuits, atmospheric noise, power line induction, poorly soldered connections, lightning storms, dirty keying contacts, and such similar disturbances.

3. End distortion is the uniform displacement of mark-to-space signal transitions with no significant effect on space-to-mark transitions. It is caused by the combination of resistance, inductance, and capacitance in the circuit.

4. Characteristic distortion is a repetitive displacement or disruption peculiar to specific portions of the signal. It normally is caused by maladjusted or dirty contacts of the sending equipment. It differs from fortuitous distortion in that it is repetitive instead of random. An example would be the repeated splitting

of the third code element of a teletypewriter signal.

The components of distortion, with their causes and effects, have been only briefly defined here. The proper recognition, identification, and correction of signal distortion is a job for maintenance personnel, using special test equipment designed for the purpose.

### ORIENTATION RANGEFINDER

Every teletypewriter has an orientation range-finder. By means of the rangefinder scale, the operator can set the machine at the range of best signal reception. Low equipment range indicates only a lowered operating margin. It does not clearly indicate whether the cause is distortion or a badly adjusted teletypewriter.

Refer again to figure 10-2, illustrating the signal for the letter R. Each unit or element is perfect in every respect. To print the letter R, the selector mechanism could be set to operate on any 20-percent portion of each unit, and perfect copy would result. Under actual conditions, a signal is never this perfect, nor is a teletypewriter expected to operate over the entire range of the rangefinder scale. Rarely is more than 70 percent of the scale usable by the selecting mechanism. This means that the selection point of the rangefinder scale must be positioned so that the best portion of the element is used by selecting mechanism.

The rangefinder shown in part A of figure 10-7 is located at the left side of model 15 and 19 teletypewriters, and at the top of model 14 reperforators. It has a scale and a movable finder arm. The rangefinder in part B of figure 10-7 is located on the right side of model 28 page printers and at the right front of model 28 reperforators. In this type of rangefinder, the range scale is moved by rotating the rangefinder knob. The indicator mark on the rangefinder plate is the reference point for reading the scale. The following discussion applies to both types of rangefinders. Points on the scale—0 to 120—divide the first unit of the signal only, not the entire signal. When you adjust the rangefinder, you shift the selection point of the first unit with respect to the starting unit. Figures 10-8 and 10-9 illustrate this. Because all other units of the signal follow at 22-millisecond intervals, this amounts to adjustment or orientation of the entire signal to the start pulse. Shifting the point of selection simply means you are moving the first black bar shown in figure 10-6 back and

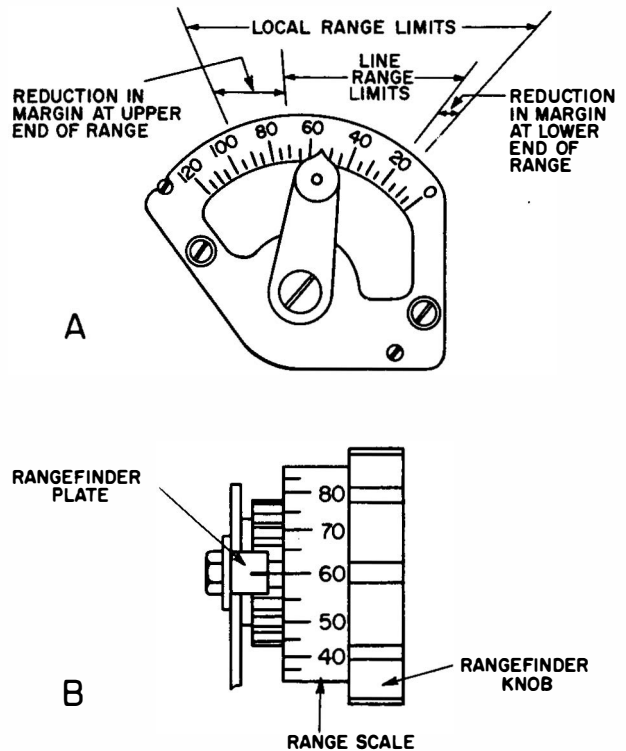

1.202  
Figure 10-7.— Two types of orientation rangefinders.

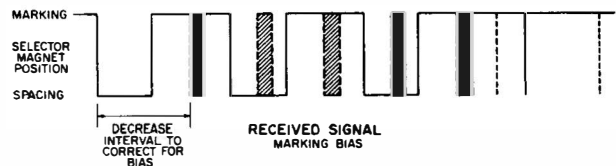

1.203  
Figure 10-8.— Signal with marking bias.

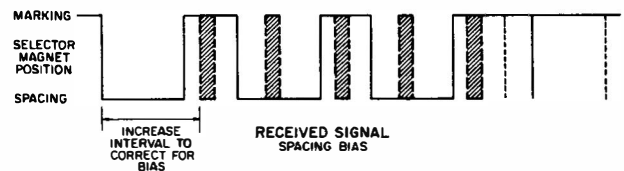

1.204  
Figure 10-9.— Signal with spacing bias.

forth across the first signal unit, looking for the most suitable position. The scale goes up to 120, hence you can shift far enough so that the selection interval moves entirely off the unit. Even if the signal were perfect, you could still shift the finder far enough to produce errors.

The object is to place the selection interval on that portion of the unit that will give the selecting mechanism a maximum margin of safety while selecting that unit and the four that follow. With the selection point midway between the transitions, there is the least chance of error.

To determine the range limits, the finder is adjusted at the two extreme positions—at the lower and the upper end of the scale. In each, observations are made of the typed record and a reading is taken when about one error is typed per line of copy. This means about one error in 69 characters. Orientation ranges on properly adjusted teletypewriters for different degrees of signal distortion are as follows:

#### Points

Very little distortion...	80
Moderate distortion....	60-70
Average distortion....	50
Large distortion.....	Less than 40

As shown in figure 10-7(A), the orientation range limits with practically perfect signals and a teletypewriter in good condition should be 15 and 95. In this instance, best operating results are obtained when the finder arm of the receiving teletypewriter is set at the midpoint (55) of this range.

Actually, the orientation range is determined twice: First, range of the machine (local range) is determined, then range of machine when connected to the line (line range) is determined. Setting of the finder arm is the midpoint of the sum of these two ranges.

The orientation range is obtained locally by using keyboard signals or running a test tape through the transmitter distributor. Normally, the letters R and Y are used because they give a complete reversal of impulses. Letter R is S-M-S-M-S and Y is M-S-M-S-M. (Other characters, such as S and G, can be selected and will also give a complete reversal of impulses.) If the range is not less than about 70 points (from about 20 to 90 on the scale), it may be assumed that the machine is satisfactory.

The difference between the range determined by local test, and the corresponding range obtained when receiving signals over a line, represents the reduction in margin due to signal distortion. The reduction, as illustrated in figure 10-7(A), is a direct measure of total signal distortion. This illustration shows the line range limits to be 20 and 70 on the scale. The line range represents a reduction of local range limits by 5 points on the lower end and 25 on the upper.

The manner in which typed errors occur in the neighborhood of the orientation limits may give indication of the nature of the distortion. If limits are fairly definite—the copy changes from good to bad when the rangefinder is moved only a small distance—bias, or distortion due to speed variations or faulty apparatus, is present. If there is a certain range at each limit over which certain characters are consistently in error, this is due to characteristic distortion. If limits are not definite—that is, there is a range over which errors occur, and errors do not occur consistently on certain characters—this is an indication of fortuitous distortion. As a general rule, characteristic and fortuitous distortion cause reduction of the range at both limits. On the other hand, bias affects one range more than the other. Marking bias reduces the upper range limit, and spacing bias reduces the lower range limit.

Maintenance men sometimes test distortion tolerance of a teletypewriter by applying pre-distorted signals. This predistortion ranges from zero to 40 percent. A well-adjusted machine types correctly when signals from a test set are distorted as much as 35 percent.

Normally, rangefinding a teletypewriter is not an everyday occurrence. It usually is performed in conjunction with maintenance of the machine. Unless something goes wrong with the circuit, rangefinding is done during maintenance periods. When rangefinding a machine, care must be taken that the machine is in good adjustment, and range limits are read accurately.

#### CIRCUIT TYPES

The word "circuit" is used in two senses in the Radioman's work. First, in the electrical sense: a continuous conductor for the flow of electrons; second, in the communication sense: a path between two or more points, capable of providing one or more channels for the transmission of intelligence. In the discussion of teletypewriter operation we shall concentrate on the communication sense of the word.

A duplex circuit is a circuit between two stations that permits the uninterrupted exchange of information by employing two separate electrical paths. Each station may transmit and receive simultaneously. The term full-duplex sometimes is substituted for the term duplex.

A half-duplex circuit is a single electrical path used for transmitting information from one station to another. The circuit has no provision for the exchange of information, but may

comprise any number of receiving stations. Each station receives only or transmits only, depending on its intended function. The fleet broadcast is an example of a half-duplex circuit.

A simplex circuit embraces features of both the duplex and half-duplex type circuits. The simplex circuit consists of a single electrical path over which two or more stations may exchange information. Any station may transmit and receive, but not simultaneously.

You learned in your study of amplitude modulation in chapter 9 that whenever a carrier is modulated, two sideband frequencies are produced that carry the intelligence present in the audio frequency. Only one sideband is necessary for transmission of the signal, and a transmitter in which the carrier has been suppressed may be used to send a separate message on each of the sidebands. The messages from the two audio channels are made to modulate the same carrier, but modulation takes place in different modulators.

The output of the two modulators contain sidebands formed by heterodyning the individual audio signals with a common carrier suppressed in the output. The filters remove the lower sideband from one modulator output and the upper sideband from the other. Thus, each of the two sidebands conveys a separate message and may be used as a separate channel. At the receiving end, the carrier frequency is reinserted and the intelligence recovered.

As used in the Naval Communication System, up to 16 teletypewriter channels are transmitted on one sideband of each SSB circuit through a frequency multiplexing system. Frequency multiplexing is a process for including multiple sets of transmissions on a single bandwidth by crowding, or "stacking" the individual frequencies.

To give added range to landline transmissions, repeaters are inserted in the line to renew the strength of weak signals as they pass through the wire. Repeaters are of two kinds. First, there is the "straight" repeater, which strengthens (amplifies) the signal just as it is received. Unfortunately, this type also amplifies any interference the signal may have picked up along the wire.

The other repeater is the "regenerative" type. It builds, or regenerates, an entirely new signal from one that is worn out or distorted, and eliminates the interference. Both types of line repeaters retransmit signals automatically, using a local source of power. They may be

placed at the end of the line (terminal) or at an intermediate point along the line.

Repeaters cannot be used with RATT transmissions. Radioteletypewriter is further handicapped by the same atmospheric disturbances that sometimes hamper radiotelegraph communications. Although RATT transmits on radio waves instead of wires, the basic equipments are the same as those used in landline teletypewriter operation. The difference is that RATT requires transmitters and receivers to send and pick up signals.

### THE TELETYPEWRITER

The teletypewriter, of course, is little more than an electrically operated typewriter. The prefix "tele" means "at a distance." Coupled with the word "typewriter" it forms a word meaning "typewriting at a distance." By operating a keyboard similar to that of a typewriter, signals are produced that print characters in page form, called hard copy.

The characters appear at both sending and receiving stations. In this way, one teletypewriter will actuate as many machines as may be connected together. An operator transmitting from New York to Boston will have his message repeated in Boston, letter by letter, virtually as soon as it is formed in New York. The same will apply at all receiving stations that tie into the network. One commonly used machine is the model 28 page teletypewriter, also called the model 28 printer, a machine widely used by both military and commercial communication systems.

### MODEL 28 TELETYPEWRITERS

Model 28 is a manufacturer's designation applied to a complete line of teletypewriter equipments. Compared with some of the older models that we will discuss, the components of the model 28 series feature smaller size, lighter weight, increased speeds, quieter operation, and less maintenance. They are also better suited for shipboard use under severe conditions of roll, vibration, and shock.

One component of the model 28 line (designated TT-48/UG) is the keyboard-sending and page-sending and page-receiving teletypewriter shown in figure 10-10. Let us look at some of the external features of this machine. The numbers following correspond to those shown in figure 10-10.

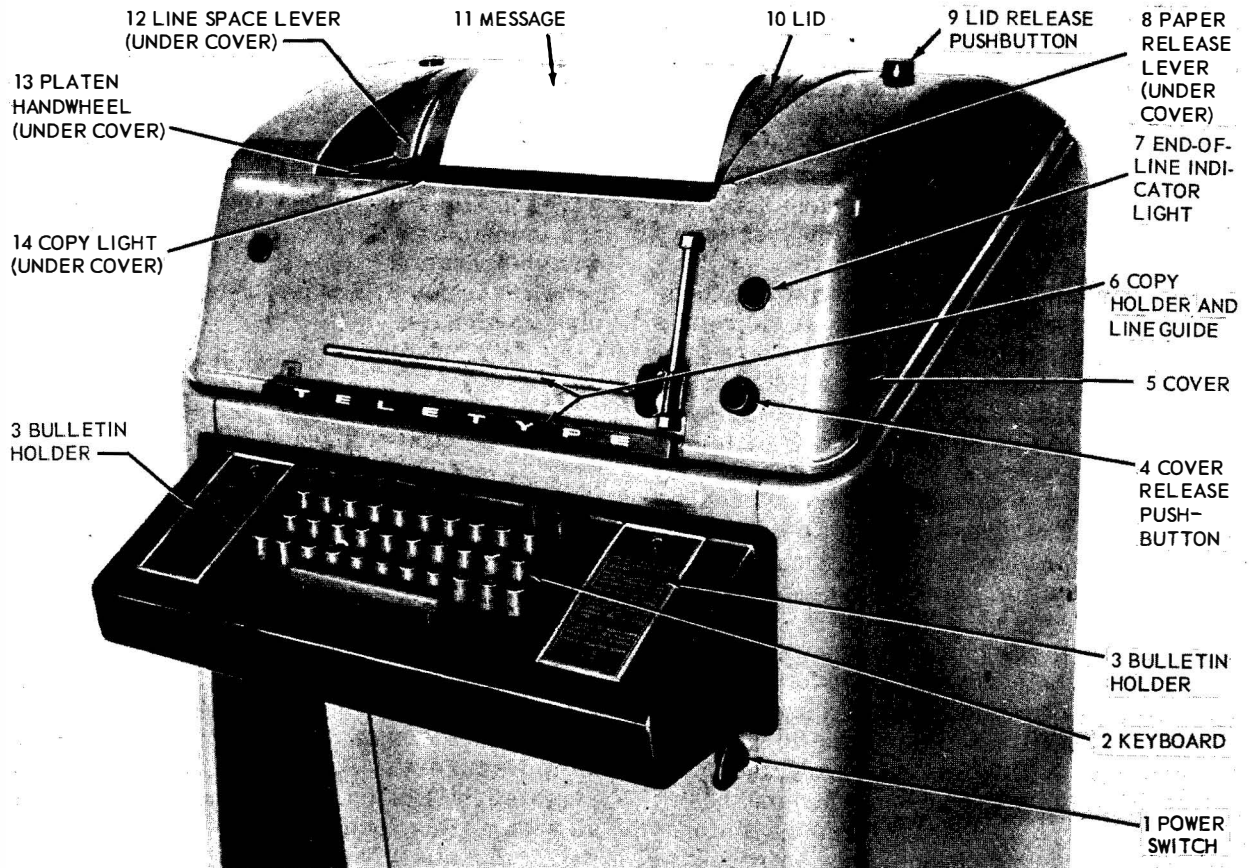

Figure 10-10.— Model 28 teletypewriter (TT-48/UG). <sup>1.217</sup>

1. **POWER SWITCH**—When turned ON, this switch starts the motor in the teletypewriter, and makes the machine operative. To secure the machine, turn the power switch OFF.

2. **KEYBOARD**—Described in next section.

3. **BULLETIN HOLDERS**—There are two on the machine. Used as necessary for recording any information an operator needs to have at his fingertips.

4. **COVER RELEASE PUSHBUTTON**—Releases cover of machine for raising.

5. **COVER**—Raised for access to typing unit. It is hinged at the rear and is counterbalanced by a mechanism that aids in lifting and holding it open.

6. **COPY HOLDER AND LINE GUIDE**—The copyholder holds the message to be typed. The line guide helps the operator follow the lines as he types.

7. **END-OF-LINE INDICATOR LIGHT**—A red lamp that lights about six characters from

the end of the line. The machine is adjusted to type 69 characters to the line, including spaces between words or groups.

8. **PAPER RELEASE LEVER**—Located under cover. When pushed back, this control frees the paper for adjustment. When pulled forward, it holds the paper tight.

9. **LID RELEASE PUSHBUTTON**—When pushed, releases lid of machine for raising.

10. **LID**—When raised, provides access to the paper, paper release lever, and line space lever.

11. **MESSAGE**—In the form of hard copy.

12. **LINESPACER LEVER**—Located under cover. Pull forward to single space, push back to double space.

13. **PLATEN HANDWHEEL**—Located under cover. When depressed and turned, feeds paper in direction in which turned, up or down.

14. **COPY LIGHT**—A clear lamp that is lit while the teletypewriter is on, illuminating the copy.

## KEYBOARDS

The model 28 printer is equipped with either of two types of keyboards: communication or weather. The first contains letters and punctuation marks common to the standard typewriter, and the weather keyboard provides necessary symbols for transmission of weather data. Similarities and differences in the two keyboards are illustrated in figure 10-11. Observe that the lowercase characters are the same, and that letters of the alphabet appear in the same positions. The difference lies in the uppercase of the bottom two rows. A trained operator can use either the communication or weather keyboard without loss of speed or efficiency.

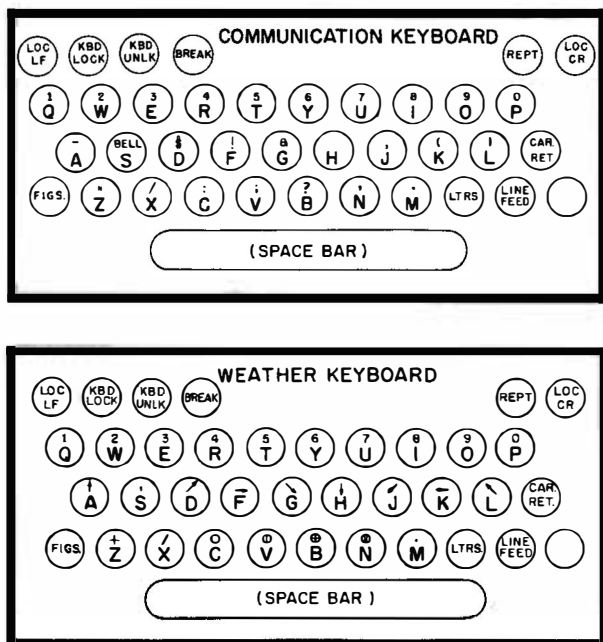

Figure 10-11. — Two types of teletypewriter keyboards.

Figure 10-12 is another illustration of the communication keyboard with emphasis placed on the function keys. The action performed by the function keys is described as follows:

1. **SPACE BAR**—The space bar, located at the front of the keyboard, is used to send spaces (as between words).

2. **CAR RET** (carriage return)—The carriage return key is used to return both the type box carriage and the printing carriage to the left to start a new line of typing.

3. **LINE FEED**—When depressed, this key causes the paper to feed upward one or two spaces depending upon the position of the single-double line feed lever located on the typing unit.

4. **FIGS** (figures)—The figures key is pressed to condition the machine for printing figures, punctuation marks, or other uppercase characters.

5. **LTRS** (letters)—The letters key is used to condition the machine for printing the letters (lowercase) characters.

6. **BELL**—Operation of the BELL key (which is uppercase action of the S key) causes a signal bell to ring locally and at distant stations.

7. **BLANK** (unlabeled key in bottom row)—Depressing the blank key twice (effective in either uppercase or lowercase) locks all keyboards in the circuit and renders them inoperative by setting up the receive condition. Restoration to the send condition is accomplished, under individual circumstances, through operation of the KBD UNLK key by the operator desiring to send from his keyboard.

8. **BREAK**—To stop (break) another station's sending, depress the BREAK key for about 3 seconds. This causes the KBD LOCK key to drop and lock keyboards on both sending and receiving machines. After a break it is necessary to operate the KBD UNLK key to free the keyboard for sending.

9. **REPT** (repeat)—To repeat a character, depress the character key and the REPT key. The character will be repeated automatically at line speed as long as both keys are held down.

The four keys described next perform their functions only on the machine on which the key is operated (referred to as "local machine"), without affecting any other machine on the line.

10. **LOC LF** (local line feed)—To feed the paper up in the local machine, depress the LOC LF key, which feeds the paper up automatically and rapidly as long as it is held down. This key is for use in locally feeding up paper to tear off a message not fed up far enough by the transmitting station. It also is used when inserting a new supply of paper in the machine.

11. **KBD LOCK** (keyboard lock)—To lock the keyboard on the local machine, depress the KBD LOCK key. The keyboard is now inoperative until released by the KBD UNLK (keyboard unlock) key. The KBD LOCK key also drops automatically when the power switch is turned OFF, when the BREAK key is operated, or when a break is received.



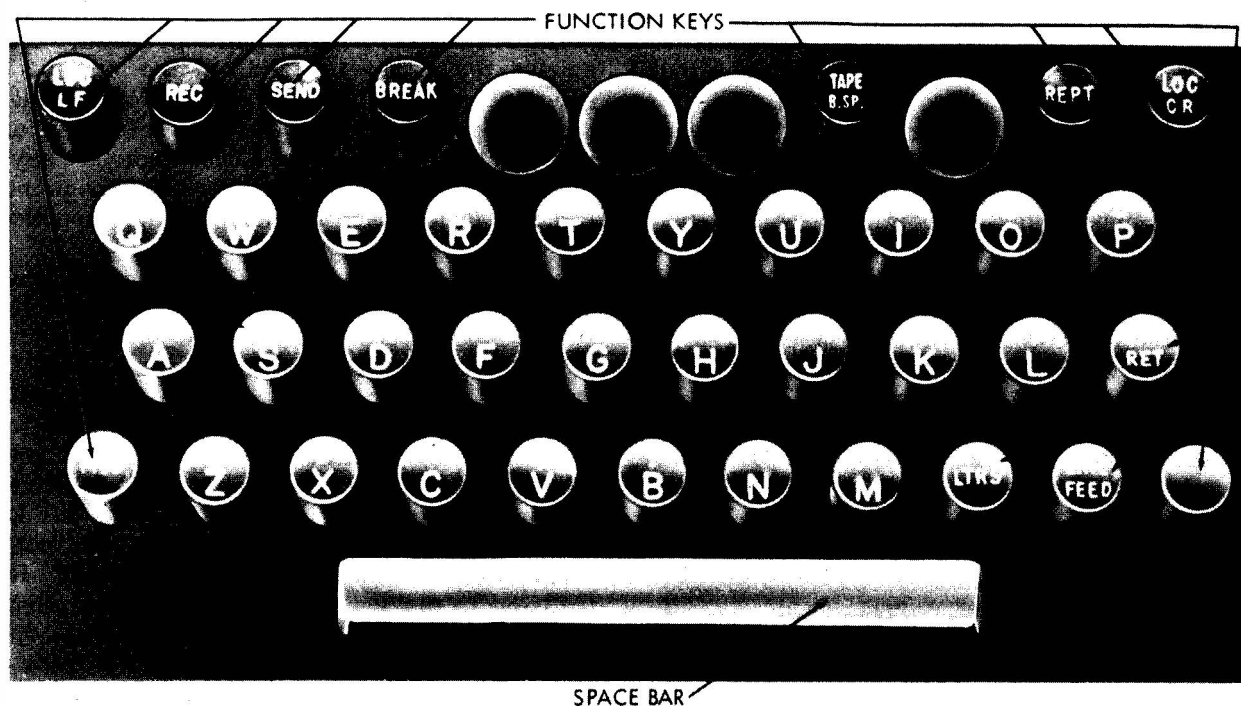

Figure 10-12.— Model 28 keyboard with emphasis on function keys. 50.93

12. KBD UNLK (keyboard unlock)—To unlock the keyboard on the local machine, depress the KBD UNLK key. This action raises the KBD LOCK key, making the keyboard operative. Operate this key after turning on the power switch and after sending or receiving a BREAK.

13. LOC CR (local carriage return)—To return the type box to the left margin on the local machine, depress the LOC CR key. This key is for use in omission of carriage return at the end of a transmission from another station.

#### TYPING UNIT

The model 28 typing unit is shown in figure 10-13. Printing is produced by the type box, which contains the characters and symbols shown on the key tops. Operation of keys and space bar moves the type box across the platen from left to right. On each key stroke the type box is moved into position for the printing hammer to strike the proper type pallet, printing the character on the paper. Operation of the CAR RET key returns the type box to the left margin, and operation of the LINE FEED key moves the paper up to the next line.

The force of the printing blow is controlled by the printing spring adjusting bracket, which is set for the individual service requirement according to number of carbon copies required. Notch 1 is for one to three copies, and notch 2 for four or five copies. If copies are either too light or too dark, the force of the printing blow can be adjusted by moving the printing spring adjusting bracket, taking care not to make the printing blow any heavier than necessary to produce satisfactory copies.

Type pallets are arranged in four rows. The type box moves up and down in selecting the row in which each character to be printed is located. Lowercase characters are in the left half of the box and uppercase characters are in the right half. The type box moves left and right on shifting and unshifting operations, rather than in the familiar up-and-down motion of carriage shifting on the typewriter and older teletypewriters. This combined vertical and horizontal motion brings the character to be printed into line with the printing hammer. There are two pointers on the type box, the LTRS pointer on the left and the FIGS pointer on the right. When typing stops, the pointer at which the printing hammer is aimed indicates where the next character will be printed.

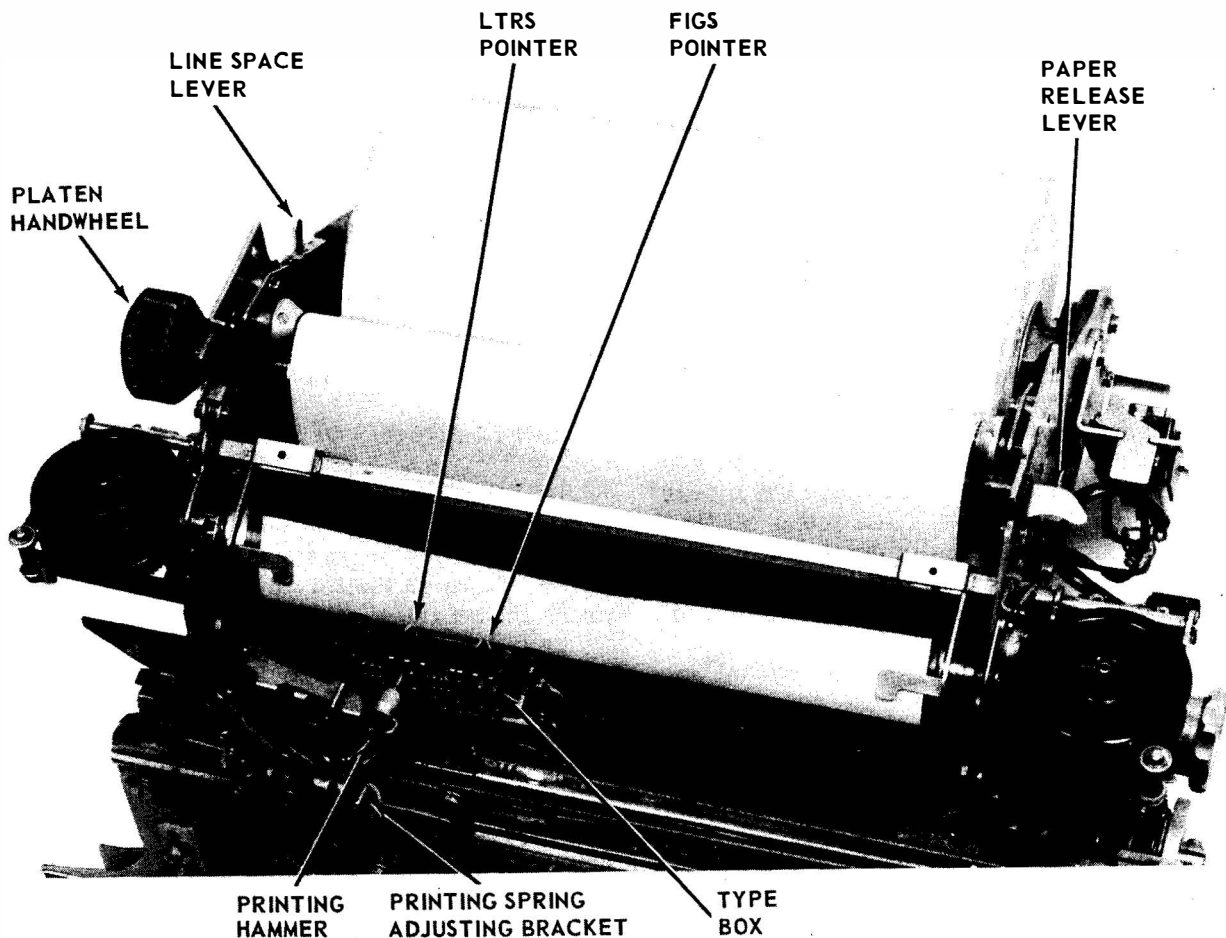

1.218

Figure 10-13.— Model 28 typing unit.

If the printing hammer is aimed at the LTRS pointer, the type box is in lowercase. If the printing hammer is aimed at the FIGS pointer, the type box is in uppercase. An operation shifting the type box to uppercase or lowercase moves the corresponding pointer to the typing location.

#### OPERATING THE MODEL 28 TTY

The controls and parts used to operate the model 28 printer are illustrated in figures 10-10 and 10-12. You will find frequent reference to these illustrations helpful in comprehending the instructions for operating this equipment.

Assuming that the printer is functioning properly and is connected to an incoming signal, the only action necessary to commence receiving traffic is to apply power to the equipment. This

is accomplished by rotating the power switch (located slightly below and to the right of the right of the keyboard) upward to the ON position. Do not be alarmed if the first few characters are garbled, because the printer's driving motor requires several seconds to attain running speed.

Conditioning the machine for transmitting is a simple process. After applying power and allowing the motor to attain running speed, depress the BREAK key and hold it down for at least 2 seconds. This locks the keyboards of all stations on the circuit. Additionally, depressing the BREAK key starts the motors of those machines in which the motor shutoff mechanism is utilized. (Model 28 printers have a mechanism that shuts off the motor when no signal is received for approximately 2 minutes, but the mechanism often is disabled by stations

not desiring this feature.) After releasing the BREAK key, press the KBD UNLK key to unlock your keyboard. The machine now is ready for transmitting to other stations.

Transmission begins at the keyboard. With the touch system, use the CAR RET key as a guide for the right hand and the A key for the left hand. The little finger of each hand is used on the guide key. It is important that you use a light, quick, even touch on the keys. Force is unnecessary because the machine is operated electrically. Teletypewriter manual operation requires accuracy, rhythm, confidence, and speed in their proper relation. Although a light touch is essential to speed, each key must be pressed in a positive manner. Otherwise you may be writing the word FOR and have FR appear on the page simply because the letter O was pressed without allowing sufficient time for printing the letter F. To become a skillful teletypist, proficiency in the touch system of typing is, of course, a "must."

The function keys represent "functional operations," or nontyping selections; that is, when pressed, they do not print anything on the page. Each function key was described in our discussion of the keyboard, but let us review the ones used most commonly in transmitting messages. These are the figures (FIGS) key, the letters (LTRS) key, space bar, carriage return (CAR RET) key, and LINE FEED key.

To shift the machine to the uppercase for typing numerals, punctuation marks, and special characters indicated on the upper part of the keys, press FIGS. To UNSHIFT the machine, press LTRS, and type the letters of the alphabet.

The space bar is used to space between either words or characters. On Navy printers the space bar functions the same whether uppercase or lowercase characters are transmitted. Some commercial machines, however, have a feature called "unshift on space," which means the printer returns to lowercase after each space. In fact, all printers have this feature, but on Navy machines it is purposely disabled. The operating procedure explained in the next chapter requires that you press the FIGS key before each group of uppercase characters so that the distant machine will print characters in the proper case whether it is adjusted to unshift on space.

The CAR RET key is used to return the carriage to the beginning of the line. Usually the machine is adjusted to print a line 69 characters

in length. This includes the spaces between the typed words. The end-of-line indicator lamp lights about six characters before the end of the line.

The LINE FEED key feeds the paper up, one to two lines at a time, thus preventing overlining.

The latter two functions, carriage return and line feed, also are performed automatically by the printer upon printing the 69th character on each line. This prevents characters piling up at the end of a line when the normal carriage return and line feed functions are not received.

### MISCELLANEOUS OPERATING FEATURES

To raise the cover for access to the typing unit to change paper and ribbon or to clean type, press the cover release pushbutton and lift the cover. To raise the lid for access to the paper, press the lid release pushbutton and lift the lid. To turn the paper up or down, raise the cover, and press and hold down the platen handwheel (so that it engages the platen ratchet wheel) while turning it in the desired direction. Do not attempt to hold down or operate the platen handwheel while the teletypewriter is operating. To adjust the paper, raise the lid, push back the paper release lever to free the paper, straighten the paper, and pull the lever forward to its normal position. To set the line spacing for single or double space, raise the lid, press the line space lever to the left and pull it forward for single space or push it back for double space. To space to a desired location for typing, space the type box over until the LTRS pointer is at the desired typing location. Then, if uppercase is desired, operate the FIGS key.

### Changing Paper

To insert a new roll of paper in the model 28, first shut off the power. Press cover release pushbutton and lift cover. (Refer as necessary to figs. 10-14 and 10-15.) Push back paper release lever, lift paper fingers, and pull paper from platen.

Lift the used roll from machine and remove spindle from core of used roll. Insert spindle in new roll. Replace spindle in spindle grooves with paper feeding from underneath roll toward you. Feed paper over paper-straightener rod, down under platen, and up between platen and paper fingers. Pull paper up a few inches beyond top of platen, and straighten it as you would

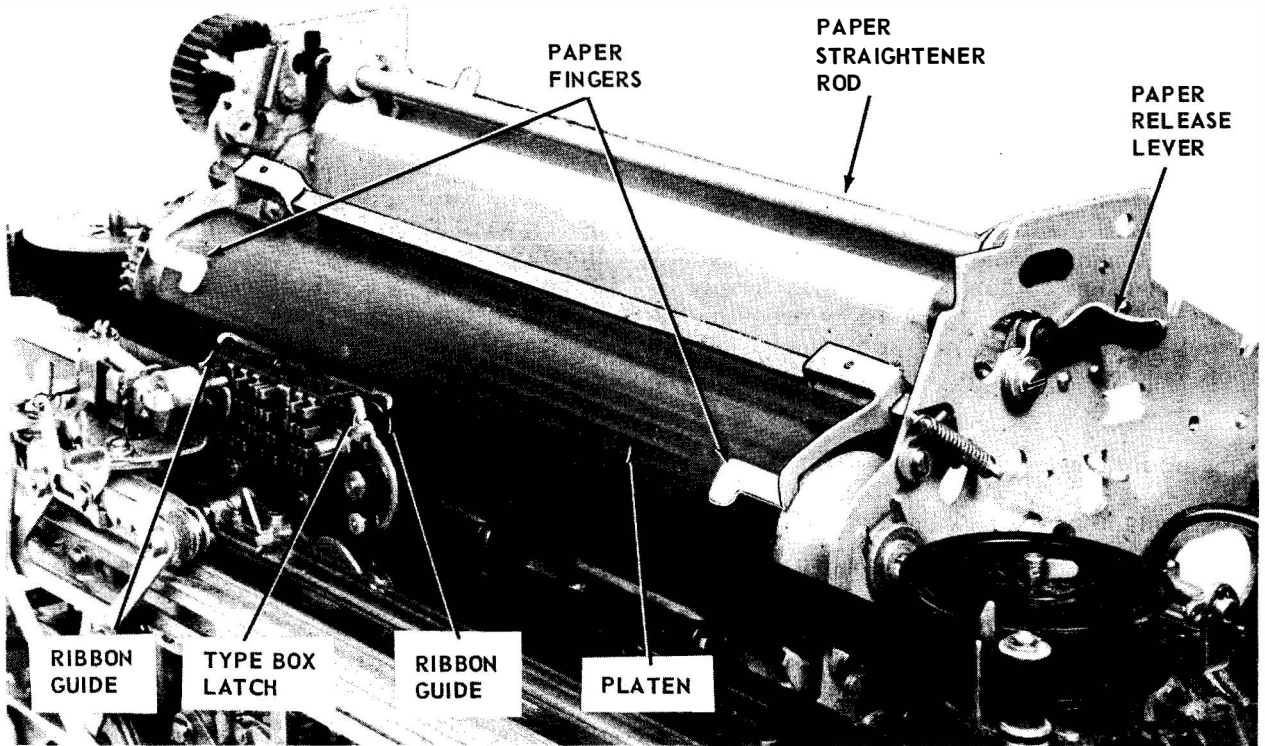

1. 219  
Figure 10-14.— Paper roll removed.

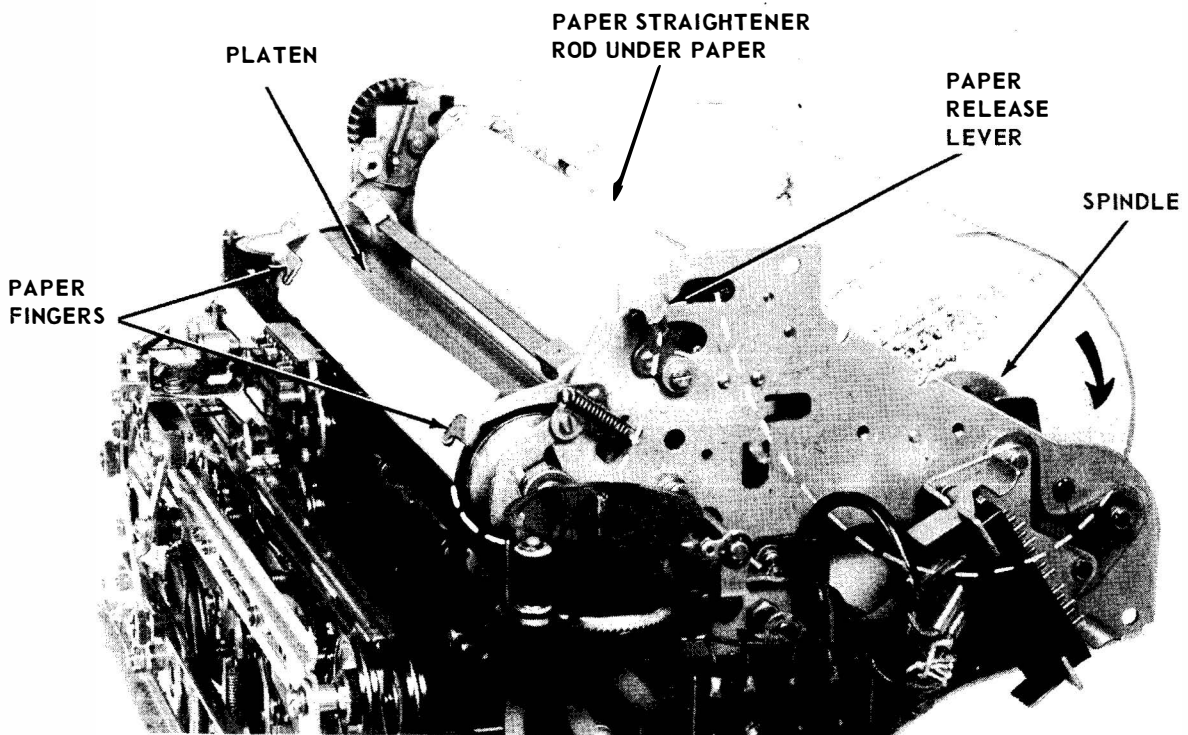

Figure 10-15.— Paper roll inserted. 1. 220

straighten paper in a typewriter. Then lower paper fingers onto paper and pull paper release lever forward.

While inserting paper, care should be taken not to disturb the ribbon or the type box latch. After paper is in place, check to see that the ribbon still is properly threaded through the ribbon guides. Also check to make certain the type box latch has not been disengaged. It should be in a position holding the type box firmly in place. Close cover. Open lid by pressing lid release pushbutton, bring up the end of the paper, and close lid with paper feeding out on top of it.

### Changing Ribbon

To replace a worn ribbon, press cover release pushbutton and lift cover. (Refer as necessary to figs. 10-16 and 10-17.) Lift ribbon spool locks to a vertical position, and remove both spools from ribbon spool shafts. Remove ribbon from ribbon rollers, ribbon reverse levers, and ribbon guides. Unwind and remove old ribbon from one of the spools. Hook end of new ribbon to hub of empty spool and wind until reversing eyelet is on the spool. If the ribbon has no hook at the end, the spool will

have a barb that should be used to pierce the ribbon near its end.

Replace spools on ribbon spool shafts, making sure they go down on spool shaft pins, and that the ribbon feeds from the outside of the spools. Turn down ribbon spool locks to a horizontal position, locking spools in place. Thread ribbon forward around both ribbon rollers, through the slots in the ribbon levers and ribbon guides. Take up slack by turning free spool. After slack has been taken up, check to make certain that ribbon still is properly threaded through ribbon guides, and that the reversing eyelet is between spool and the reverse lever. Also see that the type box latch has not been disengaged. It should be in position, holding the type box firmly in place.

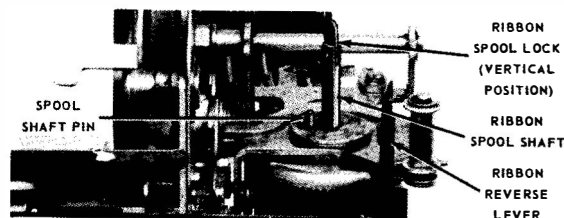

1.221

Figure 10-16.— Ribbon spool mechanism.

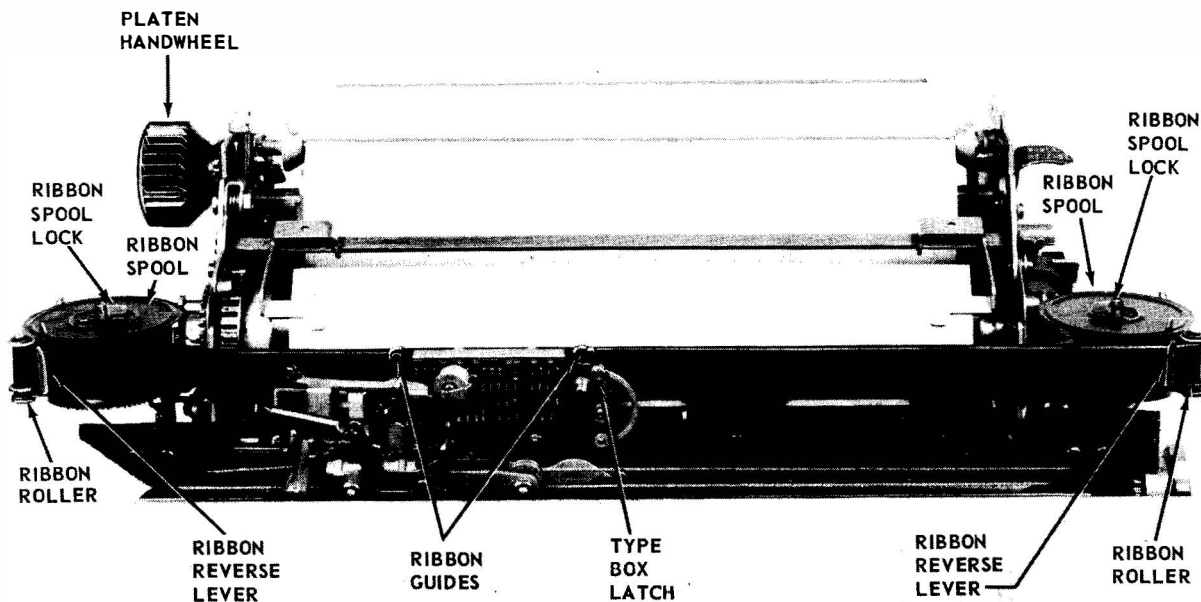

1.222

Figure 10-17.— Ribbon inserted.

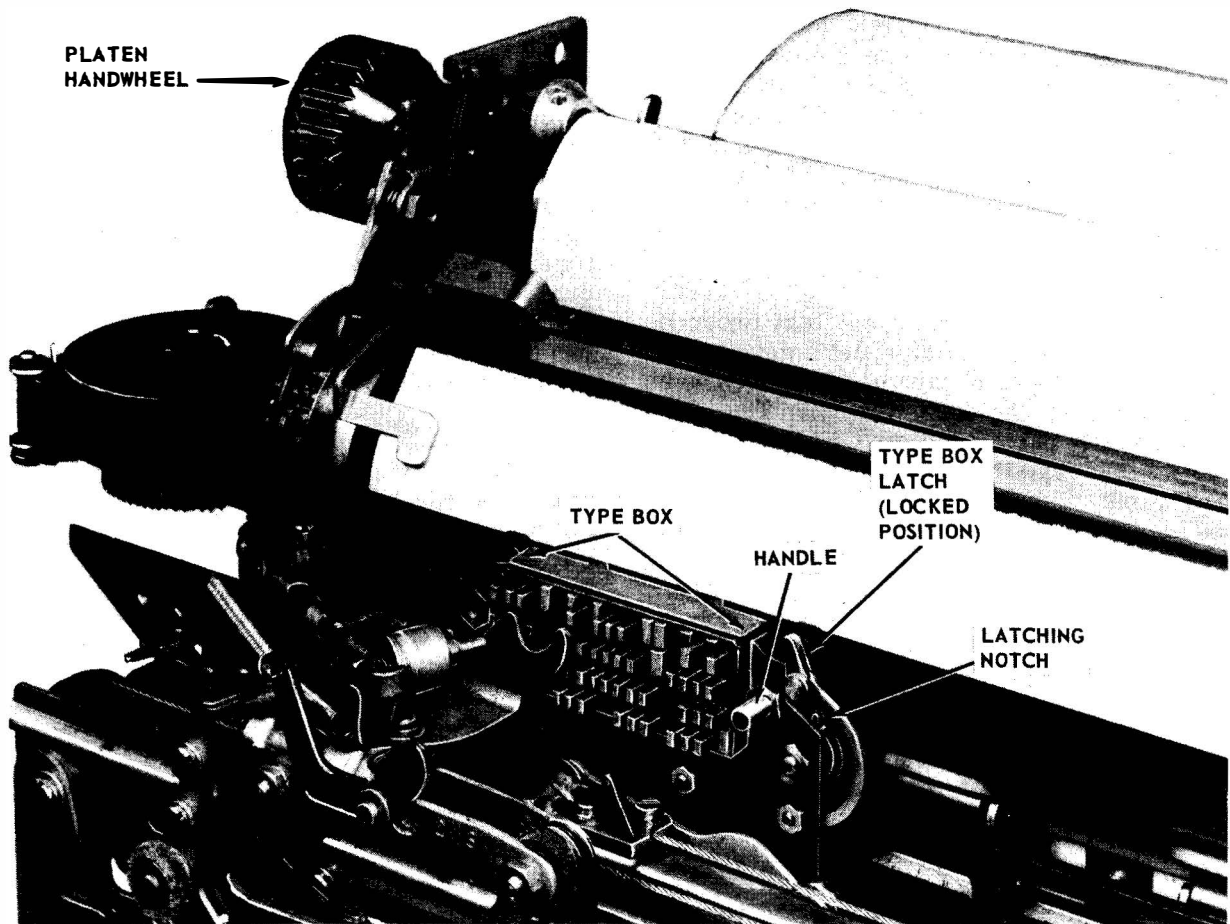

31.27  
Figure 10-18.— Type box in place.

Turn the paper up a few inches by pressing down and turning platen handwheel. Close cover. Open lid, bring up the end of the paper, and close lid, with paper feeding out on top of it.

#### Cleaning Type

When printing is smudged, the type should be cleaned. You must remove the type box from the machine. Open cover and unlock type box latch by moving it to the right (see fig. 10-18). Grasp handle on right side of type box, and raise that side up and to the left until the type box unhooks on the left side and can be freed from type box carriage. Turn type box over to side with type (fig. 10-19) and clean with a dry, hard-bristle brush. DO NOT use type cleaning solution.

To replace type box, hold it with type toward platen and the large hook on the left. Slip this

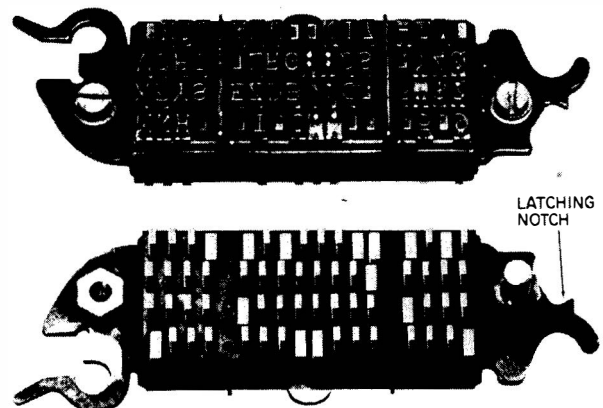

31.28  
Figure 10-19.— Type box, front and back.

hook under stud in front of left type box roller, and push smaller hook on right side down into place on stud in front of right type box roller. Hold type box latch in horizontal position and move to left over latching notch as far as it will go. Raise latch to vertical, and press to left until it locks into latching notch. Check to see that the ribbon still is threaded properly.

TELETYPE TAPE

Before discussing equipment that produces and handles messages on tape, let's get squared away on the two types of tape used for messages transmitted over the NTX system. The first type is the fully perforated, or CHAD, tape (fig. 10-20). (Incidentally, "chad" is the confetti (small paper disks) punched from the tape to make the holes.) On chad tape the teletypewriter code is completely punched, and no printing appears. The other type, only partially perforated, is called CHADLESS. There is, however, more than one kind of chadless tape. The center tape in figure 10-20 is produced by newer

models of perforators and reperforators and carries the printed message in addition to the perforations. The printing always lags the perforated code by six spaces. In other words, the pattern of holes representing letter A may be punched as the first letter of a message, and six spaces later (to the right) the letter A is printed on the tape. The reason for this is that both printing and perforating occur at the same time. Because of their simultaneous action, printing and perforating must necessarily occur at different locations on the tape. Accordingly, the machines are designed to print the character six spaced to the right of the corresponding perforation.

The partial perforations of chadless tape remain hinged to provide enough surface for the printed word, which eliminates need for reading the perforations, at the same time permitting the transmitter distributor sensing pins to penetrate the perforations and transmit the message. When a tape is completely perforated—as is chad tape—the remaining surface is not sufficient for printed characters.

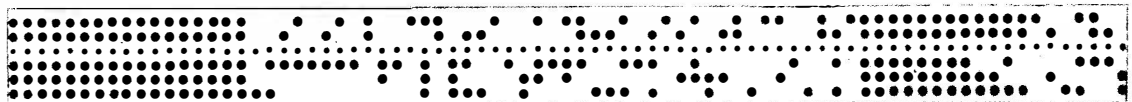

FULLY PERFORATED TAPE

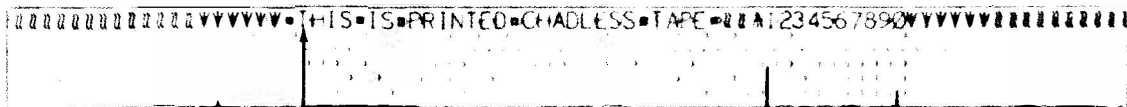

CODE CHARACTER  
 PRINTED CHARACTER IS 6 SPACES BEHIND ITS PERFORATED CODE COMBINATION  
 10 CHARACTERS PER INCH

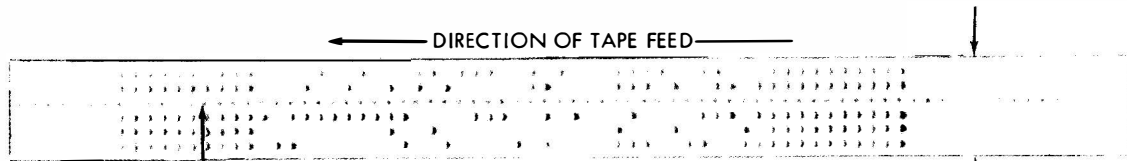

TAPE FEED HOLES  
 CHADLESS TAPE  
 11/16 INCH WIDE

1.206(76)  
 Figure 10-20.— Chad and chadless tape.

Older teletypewriter reperforators, such as the model 14, similarly produce a chadless tape different only in that the alphabet characters print along the upper edge of the tape, whereas the figures and other uppercase characters print along the lower edge.

A third kind of chadless tape has the same type of partial perforations but does not have any printing whatsoever (lower tape in figure 10-20). The teletypewriters and high-speed reperforators used on cross-office circuits at the automatic relay centers produce this kind of chadless tape.

The continued widespread use of chad tape, and chadless tape without printing, make it necessary for the operator to learn to read tape. We will have a lesson in tape reading at the end of the chapter.

MODEL 28 SEND-RECEIVE CONSOLE  
(AN/UGC-6)

The AN/UGC-6 teletypewriter (fig. 10-21) is a versatile communication equipment. It receives messages from the signal line and prints them on page size copy paper. In addition, it can receive messages and record them on tape in both perforated and printed form. With page-printed monitoring, the teletypewriter transmits messages that are originated either by perforated tape or by keyboard operation. It mechanically prepares perforated and printed tape for separate transmission with or without simultaneous transmission and page-printed monitoring.

The teletypewriter set is composed of the following components: a cabinet, a keyboard, an

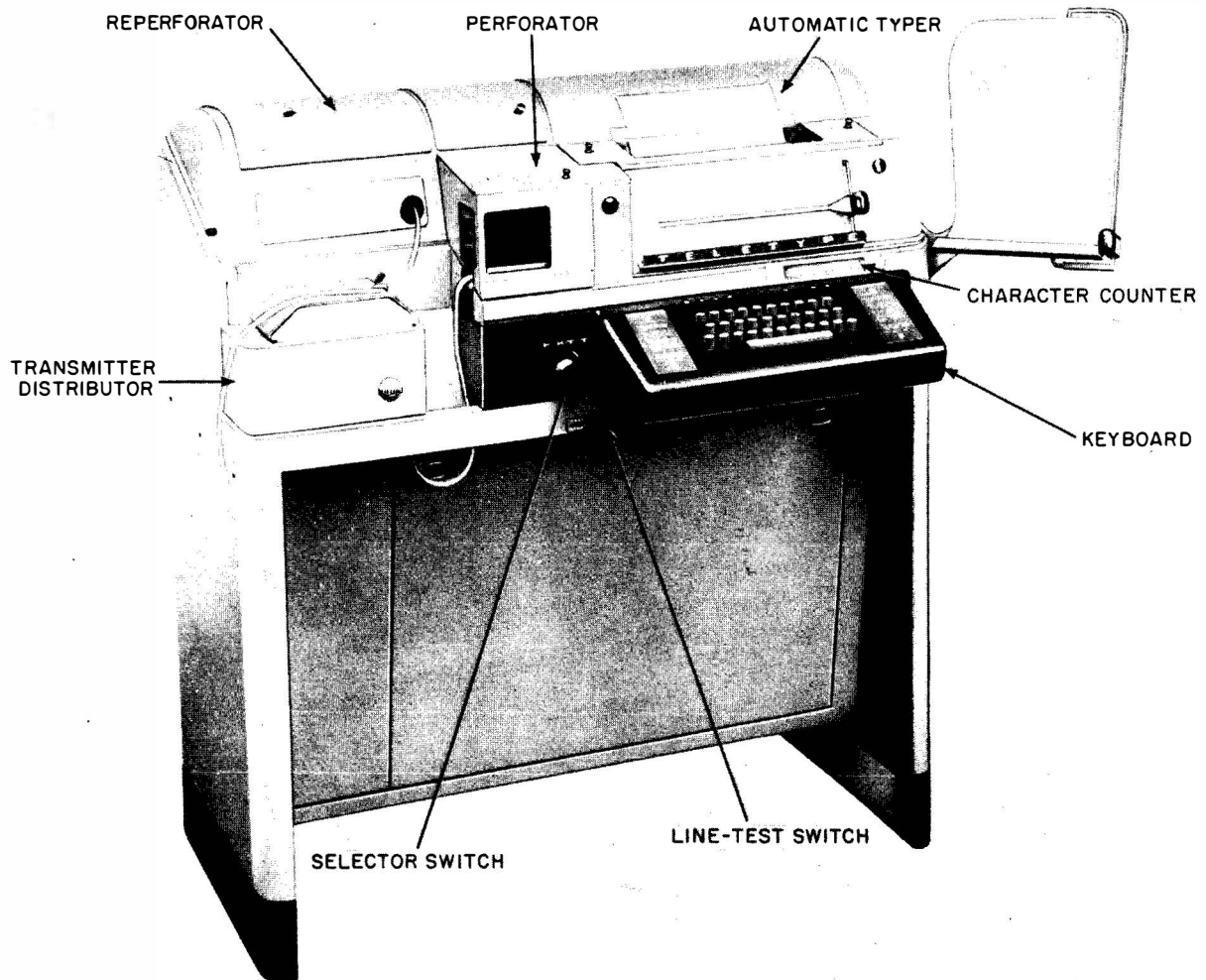

31,29A  
Figure 10-21. — The AN/UGC-6 teletypewriter.



automatic typer, a typing perforator, a transmitter distributor (TD), a typing reperforator, and power distribution panels.

In operation, the components are linked together by electrical or mechanical connections to offer a wide range of possibilities for sending, receiving, or storing teletypewriter messages. All equipment components are housed in the cabinet. Transmission signals are initiated through the keyboard or the transmitter distributor. Signals are received, and local transmission can be monitored, on the automatic typer. The typing perforator and typing reperforator are devices for preparing tapes on which locally initiated or incoming teletypewriter messages can be stored for future transmission through the transmitter distributor.

The keyboard, typing perforator, automatic typer, and transmitter distributor are operated by the motor mounted on the keyboard. Selection of these components for either individual or simultaneous operation is by the selector switch

located at the front of the cabinet, to the left of the keyboard. All these components are connected in series in the signal line, but the selector switch has provisions for excluding various components from the line. The external signal line is connected to the equipment through a line-test switch located below the selector switch on the front of the cabinet. This provides a means of disconnecting the equipment from the line for local testing of the components. The typing reperforator is operated by a separate motor and power distribution system. It also is connected to a separate external signal line.

The major components of the AN/UGC -6 send-receive console are described in greater detail in the following paragraphs and illustrations.

### KEYBOARD

The keyboard (fig. 10-22), similar to the keyboard of the TT-48/UG that we discussed earlier, actually is a keyboard and a base combined. It

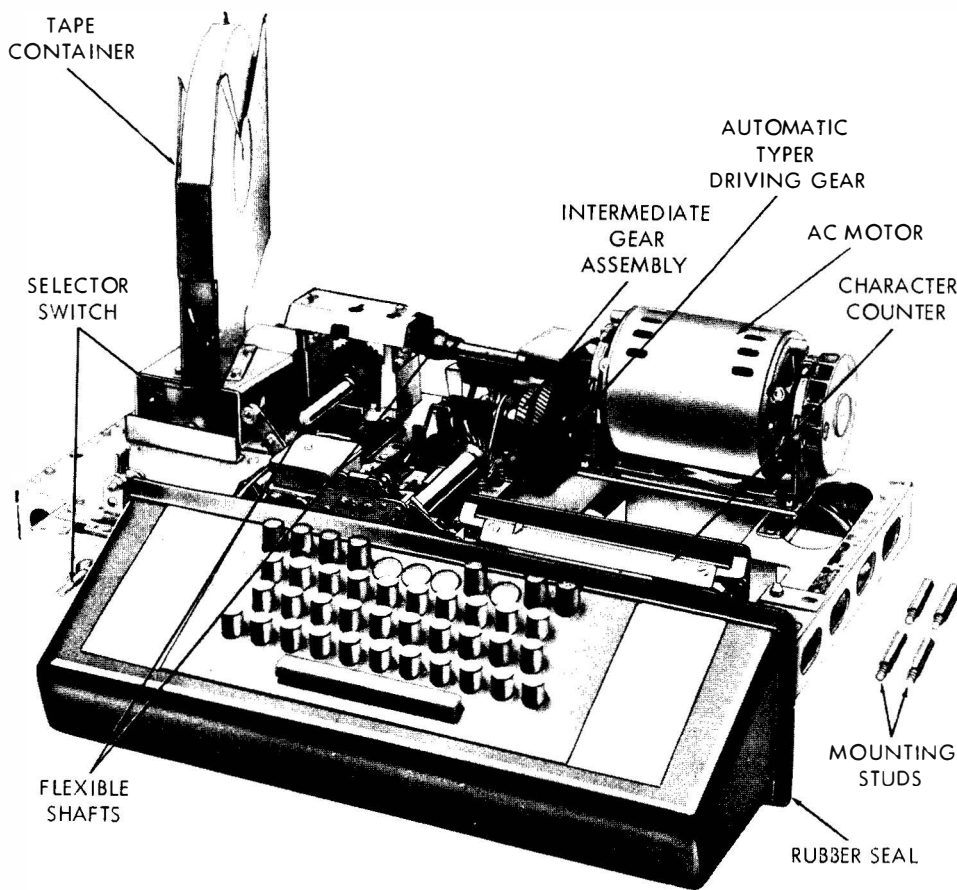

50.92  
Figure 10-22.— Keyboard unit.

provides a foundation for the motor, automatic typing unit, and typing perforator. It also supports the tape container and character counter used in connection with the typing perforator, gears for operating the automatic typer, flexible connections for operating the typing perforator and transmitter distributor, and a three-position selector switch for choosing the mode of operation of the equipment.

The keys on the AN/UGC-6 keyboard are identical to those on the TT-48/UG, except for the addition of a tape backspace (TAPE B.SP.) key in the top row. Depressing this key reverses the direction of tape feed in the perforator by one space. It is used when correcting errors in tape preparation.

### AUTOMATIC TYPER

Automatic typer is just another term for the typing unit described in our discussion of the TT-48/UG teletypewriter set. Except for minor

changes in operating features, all model 28 typing units (or automatic typers) are identical in appearance and function. They convert electrical impulses into printed matter on page form.

### TYPING PERFORATOR

Tape perforation by operation of the keyboard is accomplished by the typing perforator (fig. 10-23). The perforator is controlled by mechanical linkages to the keyboard, and is powered through flexible connections and a shaft by the a-c motor mounted on the keyboard. The tape produced by the perforator is a chadless, perforated tape with printed characters corresponding to the perforated code. Printing and perforating occur simultaneously, but the characters are printed six spaces to the right of the corresponding code combinations. Tape is supplied from a container mounted at the left rear corner of the keyboard.

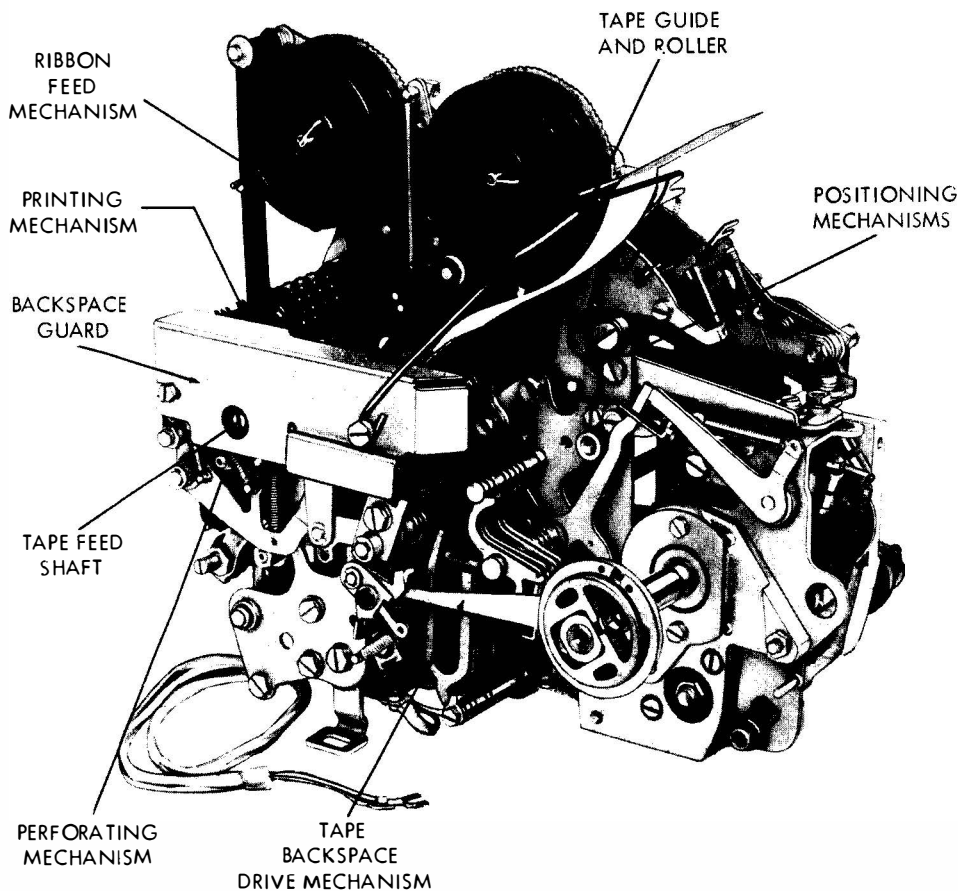

Figure 10-23. — Typing perforator (front view). 50. 98

Printing is accomplished by a type wheel that is controlled by positioning mechanisms and a hammer for driving the tape and an inked ribbon against the type wheel to imprint the selected characters. The positioning mechanisms select the proper characters by moving the type wheel in accordance with mechanical arrangements in the keyboard. The type wheel is retracted at the end of each operation, so that the last printed character is visible to the operator.

A perforating mechanism steps the tape, rolls in feed holes, and perforates chadless code holes corresponding to the code selected in the keyboard.

A backspace mechanism is wired electrically to the B. SP. key on the keyboard. Depressing the backspace key energizes a magnet that actuates the mechanism and backs the tape out of the perforator a distance of one character space.

This facilitates correcting errors in tape preparation.

#### TYPING REPERFORATOR

The typing reperforator (located in the top left compartment of the cabinet) is similar to the typing perforator, with identical subassemblies for the typing and perforating mechanisms. (See fig. 10-24.) The main difference between the perforator and the reperforator is that the reperforator is not controlled by the keyboard. Instead it has its own selector unit (similar to the one on the automatic typer) and normally responds only to a line signal received on a different line from the one serving the basic teletypewriter. This feature permits duplex operation of the AN/UGC-6 console. That is, the reperforator can be receiving traffic from

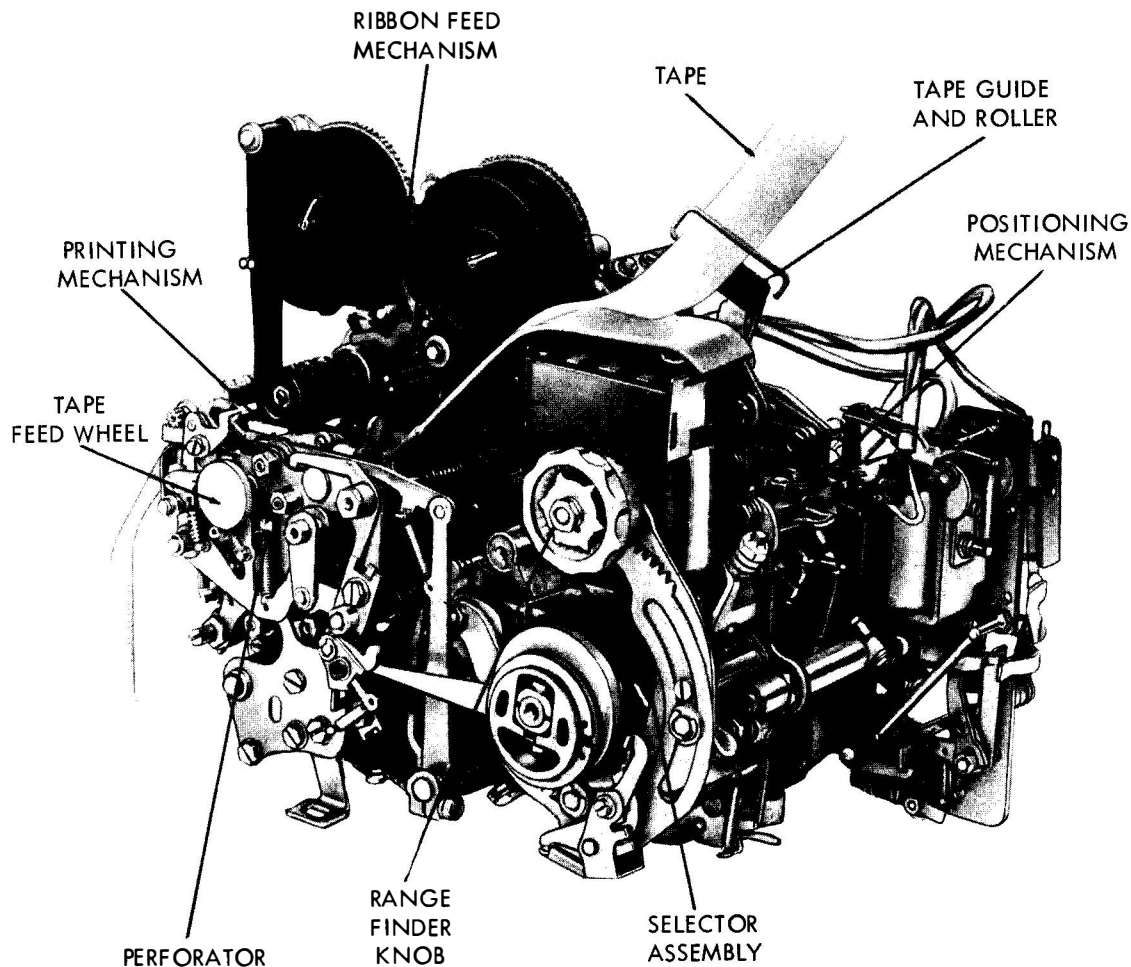

Figure 10-24. — Typing reperforator (front view). 50.102

a station on one circuit, while the other components in the console are transmitting traffic to the same station on another circuit.

Additional features of the reperforator that are uncommon to the perforator are the signal bell, low tape alarm, a mechanical variable speed drive mechanism, a blank tape feed-out mechanism, and a tape threading feed wheel.

#### TRANSMITTER DISTRIBUTOR (TD)

The transmitter distributor (fig. 10-25) is mounted on its own base in the front of the cabinet on the left side. It is a mechanical tape reader used to convert messages on standard chadless or fully perforated tapes to the electrical impulses of the teletypewriter code. The impulses are transmitted directly to the signal line or circuit.

Conversion of the perforations in the tape to electrical impulses is accomplished by passing the tape over five sensing pins. These sensing pins activate a mechanical mechanism that op-

erates a set of contacts to send out either a mark or space impulse, depending upon whether the sensing pins rise into a perforation or are held stationary by the tape.

The unit includes a start-stop switch in which incorporated tight-tape, shutoff, and free-wheeling tape features. The start-stop switch is a three-position switch. When positioned in the center, the switch is OFF and tape will not feed. When positioned to the right, the switch is in the ON (or RUN) position and tape is fed over the sensing pins. When positioned to the left, the switch is in freewheeling, and tape may be manually pulled back and fed forward without any intelligence being sent to the line.

The tight-tape lever rides on the tape as it feeds through the tape guide. If the tape becomes tight or tangled, the lever is lifted and the TD stops feeding tape. Relieving the pressure on the lever automatically starts the tape feeding again.

Another feature of the TD is the end-of-tape switch. The switch is controlled by a pin

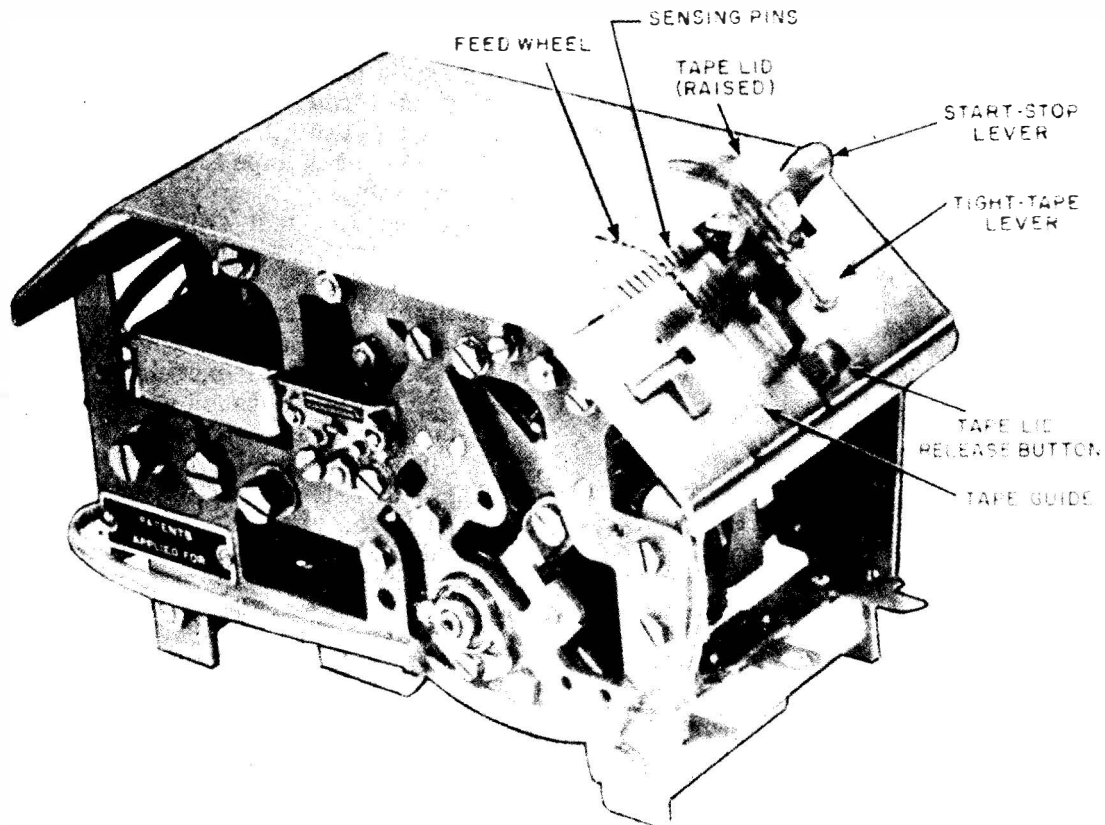

76.33  
Figure 10-25. — Transmitter distributor (TD).

protruding through the tape guide plate. As long as this pin is depressed by tape feeding through the guide, the TD is operable. When the end of the tape passes over the pin, the pin rises and the TD stops transmission automatically.

#### OPERATING THE AN/UGC-6

Power is applied to the AN/UGC-6 in the same manner as to the TT-48/UG. The switch is located on the front of the cabinet, slightly below and to the right of the keyboard. Rotating the switch so that the pointer is pointed up energizes the equipment, except for the reperforator, which is controlled by its own power switch.

After applying power, but before operating the set, ascertain that the line-test switch is in the desired position. The switch must be in the lower (LINE) position to connect the teletypewriter to distant stations. In the upper (TEST) position, the equipment is connected to a local test circuit (if wired), and no intelligence is sent to the signal line. This, of course, does not affect the reperforator, which is connected to its own external line.

With power applied, and the line-test switch in the LINE position, select the desired mode of operation with the three-position selector switch (fig. 10-26). From left to right, the three positions of the switch are keyboard (K), keyboard and tape (K-T), and tape (T).

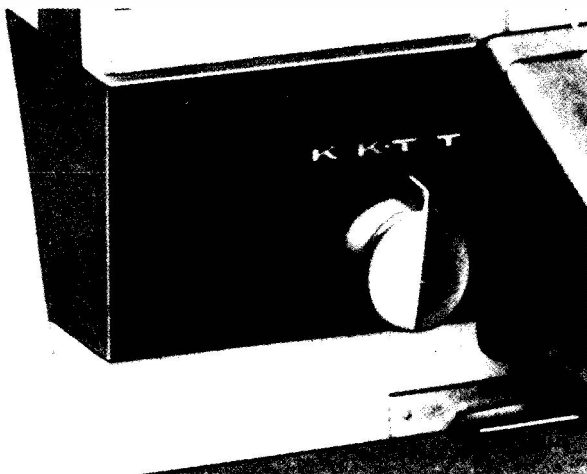

76.34  
Figure 10-26. — Selector switch.

#### KEYBOARD MODE OF OPERATION

To transmit a message directly to the line as you are typing it, rotate the selector switch to the K position. Depress and hold down the BREAK key for approximately 2 seconds to lock out all keyboards in the circuit, and then depress the SEND (KBD UNLK) key to unlock your keyboard. Transmit five spaces, two carriage returns, and a line feed, in that order, to align the distant machines to the same position as yours, and then type your message. The automatic typer monitors your transmission, providing you with a printed copy of the message.

In the keyboard mode of operation, the typing perforator is mechanically isolated from the keyboard, and the character counter mechanism does not function. The transmitter distributor circuits also are inoperable.

#### KEYBOARD-TAPE MODE OF OPERATION

Keyboard operation in the keyboard-tape (K-T) mode is the same as when in the keyboard mode, except that typed, perforated tape is prepared simultaneously by the typing perforator. This mode is particularly useful when a message must be transmitted on more than one circuit. You can transmit the message on one circuit while preparing a tape for transmission on the other circuits.

With the line-test switch in the TEST position, you can utilize this mode of operation to prepare tape for later transmission and, at the same time, to obtain a page copy of the transmission as it will appear when sent on the circuit. Care must be exercised in using this method, however, because you can neither send nor receive messages during the period the machine is disconnected from the circuit.

When the selector switch is in the K-T position, the character counter moves one unit to the right with each character and spacing operation recorded on the tape. The transmitter distributor also is operable.

#### TAPE MODE OF OPERATION

When the selector switch is in the T position, the keyboard and perforator are isolated from the other units. This permits you to prepare tape for transmission while transmitting messages via the transmitter distributor, or receiving messages on the printer. You type no page copy in this position, so watch the character

counter to make certain that you do not type too many characters for the length of the line. As pointed out previously, the counter registers each spacing character. Nonprinting functions, such as FIGS, LTRS, LF, and CAR RET, are not registered.

To correct an error when punching tape, depress the TAPE B. SP. key to move the tape back, one space at a time, until the first wrong code is over the perforating pins of the punch block. Press the LTRS key as many times as you have backspaced to change the incorrect codes to LTRS codes. Because it is the only character having all five perforations, the LTRS code will obliterate any other character code on the tape. This is called "lettering out" an error. After lettering out the incorrect portion, retype that part of the message. The error will not appear on the page copy when the tape is sent. The characters still are registered on the counter, however. Therefore, when the counter indicates that you have reached the end of the line, you still may type as many characters as you lettered out. Figure 10-27 shows a lettered-out tape.

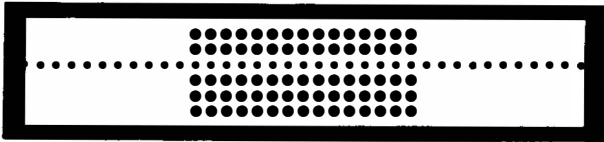

31. 24

Figure 10-27.— A lettered-out tape.

#### USING THE TRANSMITTER DISTRIBUTOR

The transmitter distributor (commonly called the TD) is operable only in the K-T and T modes of operation, and then only when the SEND key is depressed. In the following discussion of the TD, assume that the selector switch is in either the K-T or T position and that the SEND key is depressed.

To place a tape in the TD, move the start-stop lever to the center (OFF) position. Release the tape lid by pressing the tape lid release button. Place the tape in the tape guide in such a manner that its feed holes engage the feed wheel with the portion of the tape having two perforations toward the rear of the TD. Insert printed tape so that the printed, chad side is up. If nontyped chadless tape is used, position the tape so that the open side of the hinged chads is to the top. With fully perforated (chad) nontyped tape, you must be careful to feed the

tape from the beginning. Reversing the tape results in a garbled transmission. While holding the tape firmly in place on the feed wheel, press down on the tape retaining lid until its latch is caught. Move the start-stop lever to the left (FREEWHEELING) position, and manually adjust the tape so that the first character to be transmitted is located over the sensing pins. Figure 10-28 shows the path of the tape through the TD.

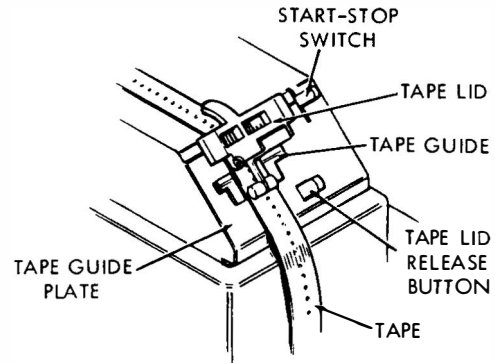

1210(76)A

Figure 10-28.— Path of tape in transmitter distributor.

To transmit from the tape, operate the start-stop lever on the TD to the extreme right (ON) position. If the tape is inserted in the TD correctly, it feeds over the sensing pins, and the message is transmitted to the signal line.

#### CHANGING TAPE

A visual indication of low tape supply is incorporated into each roll of tape. When the color of the tape changes from pale yellow to red, the roll is nearly exhausted and requires replacement. Additionally, the warning device in the reperforator's tape container is activated when the tape supply for that unit is low. Heed these warnings! Don't miss a message by trying to use up the last bit of tape on a roll.

To change tape in the perforator, set the keyboard selector switch to the T mode of operation. Raise the perforator cover, and open the lid in the center of the cabinet dome. Tear the old tape at the point where it enters the tape chute (fig. 10-29). With power applied to the equipment, depress the REPT key and any character on the keyboard until the old tape is fed out of the punch block. Then, lift the tape reel from its container and remove the remainder of the old tape from the reel. Insert a fresh roll of

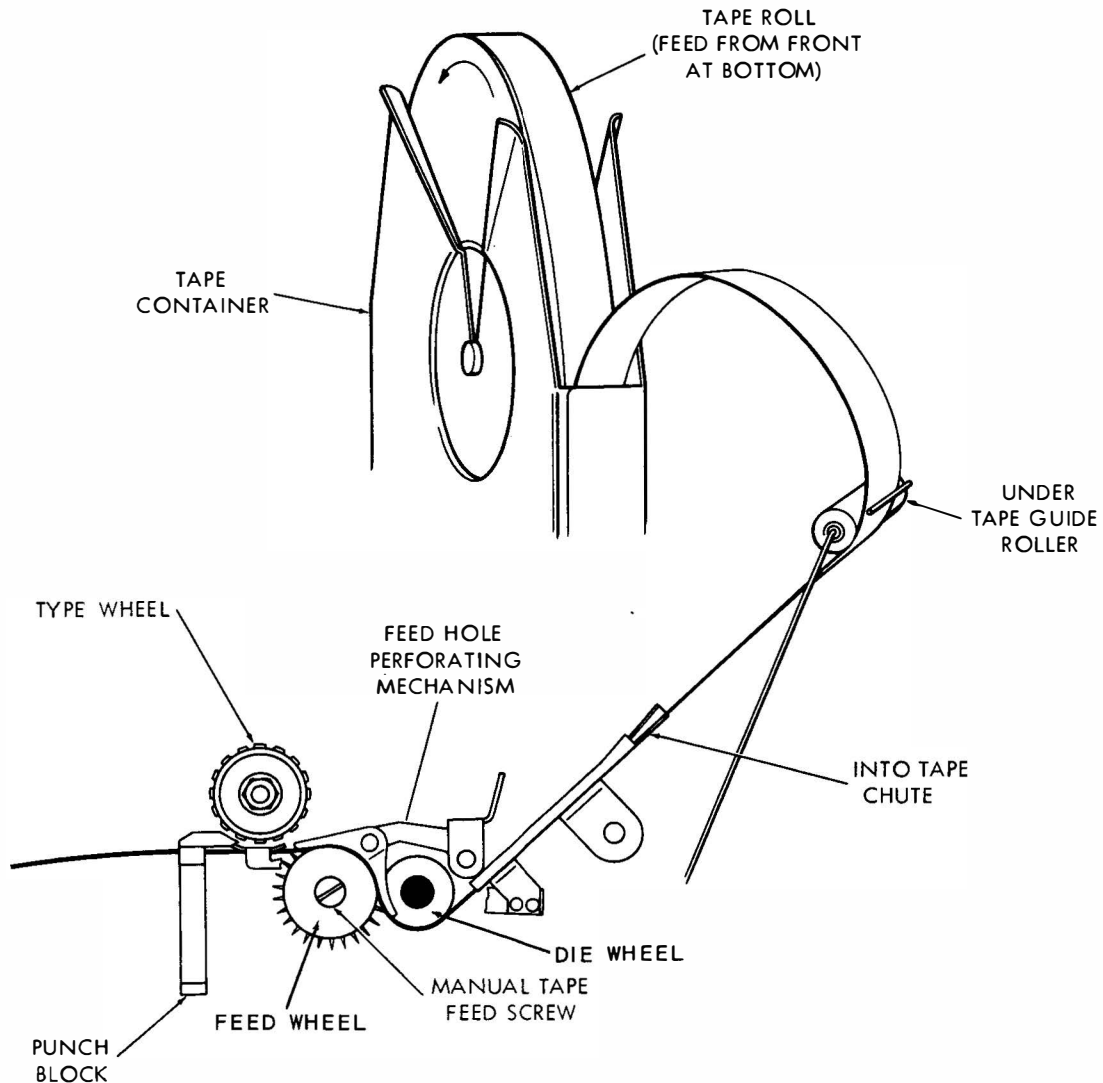

1.215(76) A  
Figure 10-29. — Path of tape in typing perforator.

tape on the reel. Place the reel back into its container so that the tape feeds from the front of the container and off the bottom of the reel. Thread the tape over the tape guide roller and into the chute of the punch mechanism. Depress the REPT key and any character on the keyboard for automatic feeding, and, at the same time, push the tape downward until it is engaged by the feed and die wheels. Continue feeding tape until the tape appears at the left side of the punch block. Close the lid in the cabinet and lower the cover over the perforator.

The procedure for changing tape in the reperforator is almost identical to that for chang-

ing tape in the perforator. The path of the tape through the two units is identical. (Refer to fig. 10-30 as necessary.)

For access to the reperforator and its tape supply, open the left rear lid in the cabinet. Tear the tape at the tape chute and clear it out of the punch block by manually rotating the feed wheel or, if the reperforator is so equipped, by pressing the automatic tape feed button. Lift the tape reel from its container, remove the old tape, and insert a fresh roll of tape on the reel. Position the reel in its container in such a manner that tape feeds from the rear of the container and off the bottom of the reel. Make

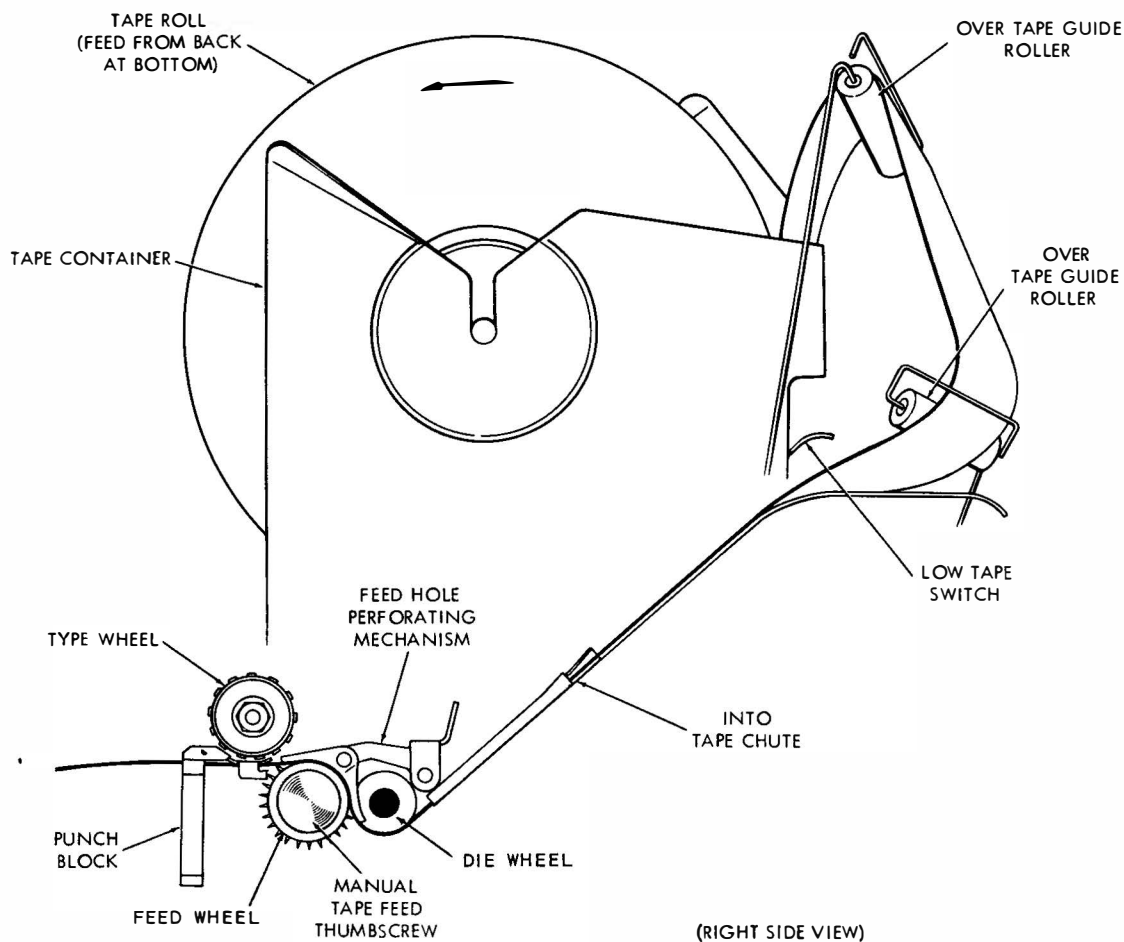

1.215(76)B  
Figure 10-30.— Path of tape in typing reperforator.

certain that the lever on the tape out switch assembly is toward the rear of the cabinet and under the roll of tape. Lead the tape over the tape roller at the rear of the tape container, to the right and over the roller mounted on the typing reperforator, and to the tape chute. Slide the tape into the chute and rotate the tape feed wheel until the tape emerges from the punch and chute at the left of the reperforator. Close the lid, making sure that the tape feeds through the hole in the front of the lid.

### CHANGING RIBBONS

You already know how to change the ribbon in the automatic typer. Now you will learn how this is done in the perforator and reperforator. The procedure for replacing the ribbon in either the typing perforator or the typing reperforator is the same.

Open the cabinet dome lid required for access to the component. Open the ribbon spool toggles and remove the old spools. Disengage the old ribbon from the reversing pins, the ribbon guide, and the rollers. Remove the old ribbon from one of the spools. Engage the hook of the new ribbon on the hub of the empty spool, and wind the ribbon on the spool past the reversing eyelet. Insert the spools on the shafts and close the toggles.

The path of the ribbon (fig. 10-31) is from the bottom of the left spool, up and over the left roller, down through the left reversing pins, through the ribbon guide under the type wheel, across the front of the unit and through the right reversing pins, under the right roller, and up and around the left side of the right spool.

Make certain that the ribbon remains in the guide slots and that both reversing eyelets are between the ribbon spools and the reverse



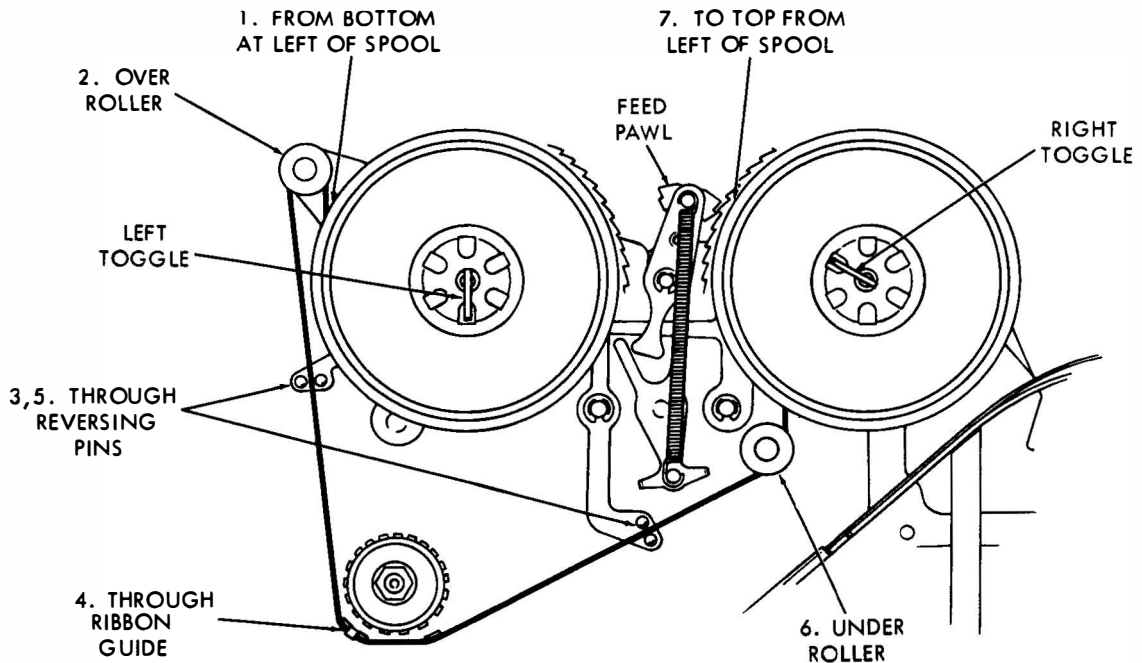

1215(76)C

Figure 10-31. — Path of ribbon in typing perforators.

levers. Roll up any slack in the ribbon on the spool on which the ribbon is being wound.

#### ADDITIONAL MODEL 28 UNITS

The design and function of the individual units in the model 28 line of teletypewriters remain basically the same, but the AN nomenclature assigned the units when they are employed separately (or in combinations such as found in the AN/UGC-6) usually is changed. Often, simply changing the style or type of cabinet in which a unit is enclosed causes a change in nomenclature. For example, when the keyboard and automatic typer comprising the TT-48/UG teletypewriter (fig. 10-10) are placed in the cabinet shown in figure 10-32, they become the TT-69/UG teletypewriter set. The latter set is designed for installation aboard ship.

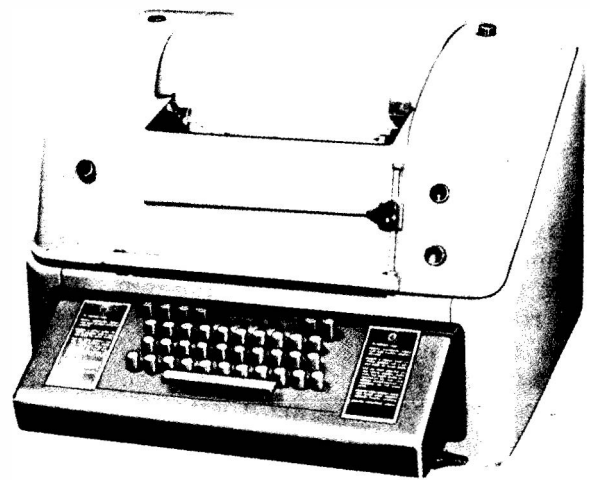

7635

Figure 10-32. — Teletypewriter TT-69/UG.

#### TYPING REPERFORATOR TT-192/UG

The typing reperforator shown in figure 10-33 is designated TT-192/UG. Basically, it is the same as the one described as a component of the AN/UGC-6. It serves the same purpose and functions in the same manner. Because of space limitations, however, most shipboard installations of the TT-192/UG do not include the

table shown in the illustration.

Normally, the reperforator's wiring is terminated in a patch panel (described later in this chapter) so that it can be patched or connected into any teletype circuit wired through the panel. By patching the reperforator into a circuit, a tape copy of each message is obtained, and messages

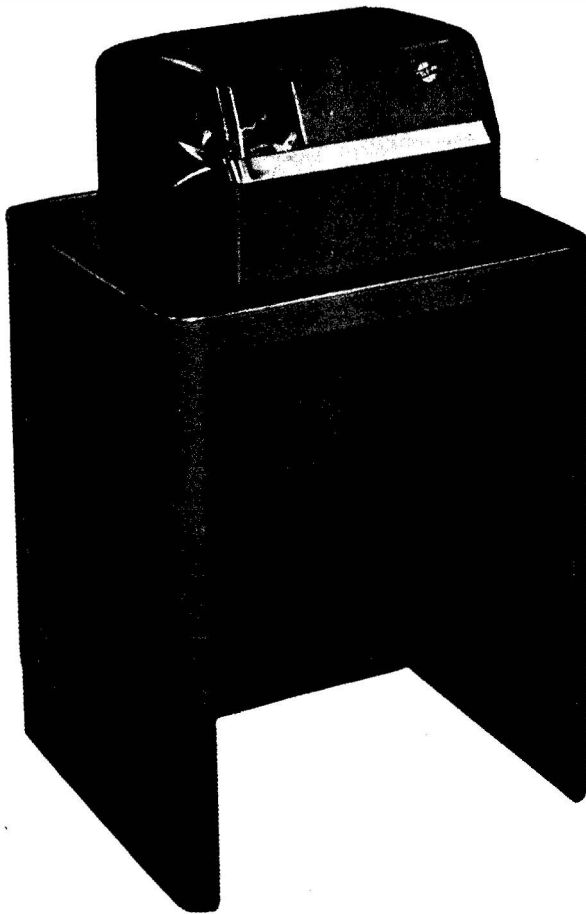

50.114(76)

Figure 10-33. — Model 28 typing reperforator set TT-192/UG.

requiring further processing in tape form need not be retyped by the operator.

#### SEND/RECEIVE TYPING REPERFORATOR TT-253/UG

Because of its versatility and compactness, the TT-253/UG send/receive typing reperforator (fig. 10-34) is installed aboard ship in large numbers. In addition to its usefulness as a regular reperforator, the set can be utilized to prepare tape for transmission and to send and receive messages in the same manner as the larger, page-printing teletypewriter sets. Its use for sending and receiving messages is, of course, restricted to situations where a page copy is not required.

#### TRANSMITTER DISTRIBUTOR TT-187/UG

With the addition of its own motor, the transmitter distributor described as a part of the AN/UGC-6 console becomes the TT-187/UG shown in figure 10-35. The unit is self-contained, and can be mounted in any convenient space that is large enough to accommodate its base.

#### OLDER TELETYPEWRITERS

The forerunners of the model 28 line of teletypewriter equipment are the model 14 typing reperforator (fig. 10-36), the model 15 page printer (fig. 10-37), and the model 19 teletypewriter set (fig. 10-38). A number of these equipments still are found at shore stations (and possibly aboard a few ships), but their use is limited because of their operating speed. The maximum operating speed of the older equipment is 60 wpm, which is incompatible with the higher speeds now employed on most Navy circuits. Consequently, as these older models age beyond economical repair, they are being replaced by components from the model 28 line.

Operating the older machines is similar to operating their model 28 counterparts. By comparing figures 10-36, 10-37, and 10-38 with the previous illustrations of model 28 equipment, it readily is seen that the location and appearance of some of the functional controls are somewhat different. But an operator familiar with the purpose of these controls can adapt easily to operating either the older models or their counterparts in the model 28 line.

#### TELETYPEWRITER SERVICE TROUBLES

Here are some of the more common service troubles you may encounter, with a brief description of how they may be recognized, their causes, and what action the operator may take to correct them.

The troubles presented here are only a representative sample of those that may be encountered. The equipment technical manuals give a thorough coverage and include helpful charts to aid in tracking down the trouble.

**MACHINE WILL NOT START:** See that the plug on the power cord from the teletypewriter is pushed all the way into the outlet. Check for a power or fuse failure. If a fuse is open, rotate the motor by hand and check for excessive bind. If the fuse is not blown, check the motor



Figure 10-34.— Send/receive typing reperforator TT-253/UG. <sup>50.116</sup>

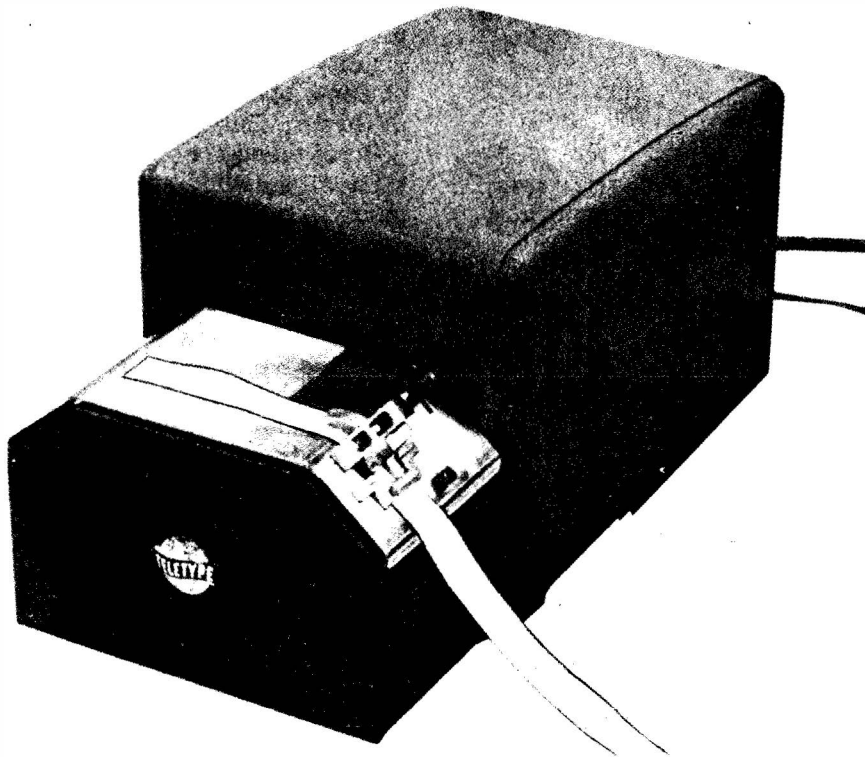

Figure 10-35.— Transmitter distributor TT-187/UG. <sup>1.210(76)B</sup>

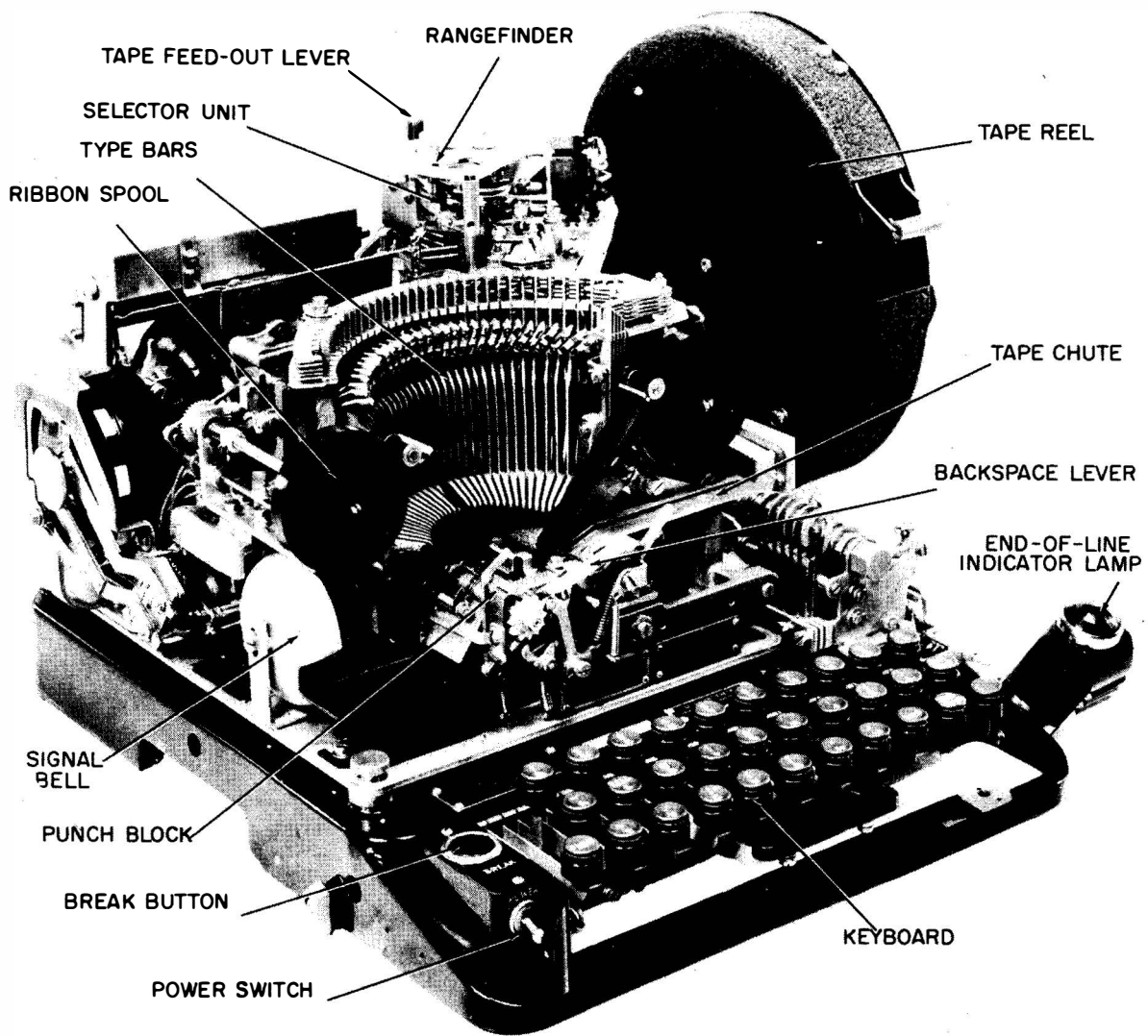

Figure 10-36. — Model 14 typing reperf<sup>31.25</sup>orator.

for excessive temperature. The synchronous motor in the Model 28 is equipped with a thermal circuit breaker that protects it against excessively high temperatures caused by a prolonged overload. If the breaker is tripped, reset it by pressing the red button on the motor plate at the rear of the motor.

**UNABLE TO COMMUNICATE WITH OTHER OFFICES:** Make sure the SEND key is depressed. Be sure the line switching lever is positioned correctly.

**PRINTER RUNS "OPEN":** This trouble may be recognized by the machine operating continuously without either printing or spacing. The machine also appears to run faster than during normal operation. Shift the line switching lever to the TEST position or patch the equipment into a test circuit as applicable. If this causes the machine to become idle, it is an indication that the trouble probably is in the incoming signal circuit.

**PRINTING ERRORS:** When printing errors occur that obviously are not typographical, some

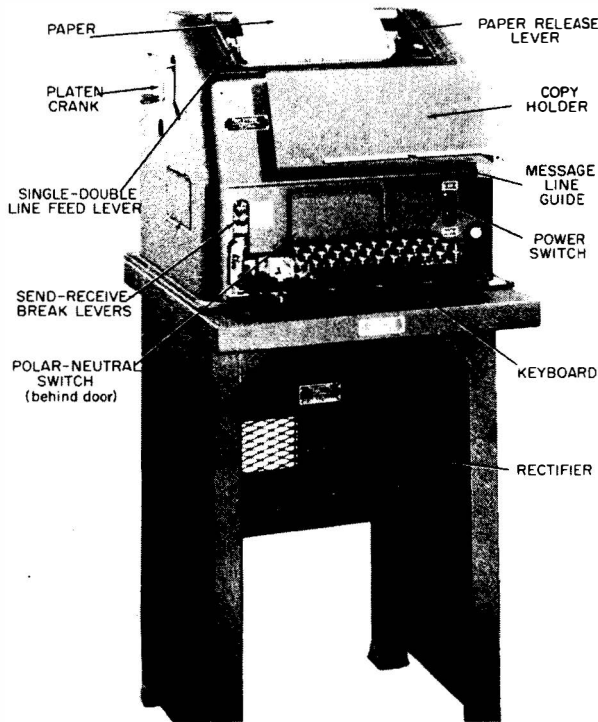

1.205  
Figure 10-37.— Model 15 page printer.

comparisons maybe made to determine whether the trouble is in the machine or the circuit. If the errors occur when you are sending, operate the line switching lever to the TEST position (or plug in the test loop) and try the machine. If the same errors occur, the trouble probably is in the machine.

If you have a spare machine, connect it to the circuit. If errors occur on both machines, the trouble is in the circuit. If the errors happen on only one of the machines, the trouble is probably in that machine.

For errors when receiving, connect a spare machine to the circuit. As pointed out already, errors on the spare machine indicate circuit trouble, and correct copy from the spare machine indicates that the first teletypewriter is causing the trouble.

**RIBBON TROUBLES:** If the ribbon is feeding and the printing is faint, a new ribbon is needed. If the ribbon is not feeding, make sure it was placed in the machine correctly.

**PAPER FEED TROUBLES:** This is indicated by the paper either feeding to one side, not feeding, tearing, or jamming. Make sure that the paper was placed in the machine as previously outlined. See that too much paper has not accumulated behind the unit. The paper may not have been torn correctly.

**UNABLE TO SEND WITH TD:** Make sure the tape was properly placed in the transmitter distributor. Check to see that the end-of-tape pin is depressed, and that the tight-tape stop lever is down. See that feed holes in the tape are not mutilated.

**TAPE FEED TROUBLES WHILE PERFORMING:** Make sure tape is feeding freely off the roll, and that it was placed in the machine correctly.

**FAILURE ON LINE FEED:** There may be binds in the moving parts of linkage for line feed function. Check these parts for freeness.

**FAILURE TO PRINT:** This may be due to binds in the printing carriage assembly. Check for freeness in moving parts, and for missing springs. Another source of this trouble may be the improper installation of the ribbon.

**NO SIGNALS FROM KEYBOARD:** This trouble may stem from either an open or a closed signal line. The contacts should be checked to determine if they are dirty or shorted.

**INTERMITTENT ERRORS:** This trouble may have a variety of sources. Among them are inadequate or excessive line current, range finder set beyond range limits, or incorrect adjustments.

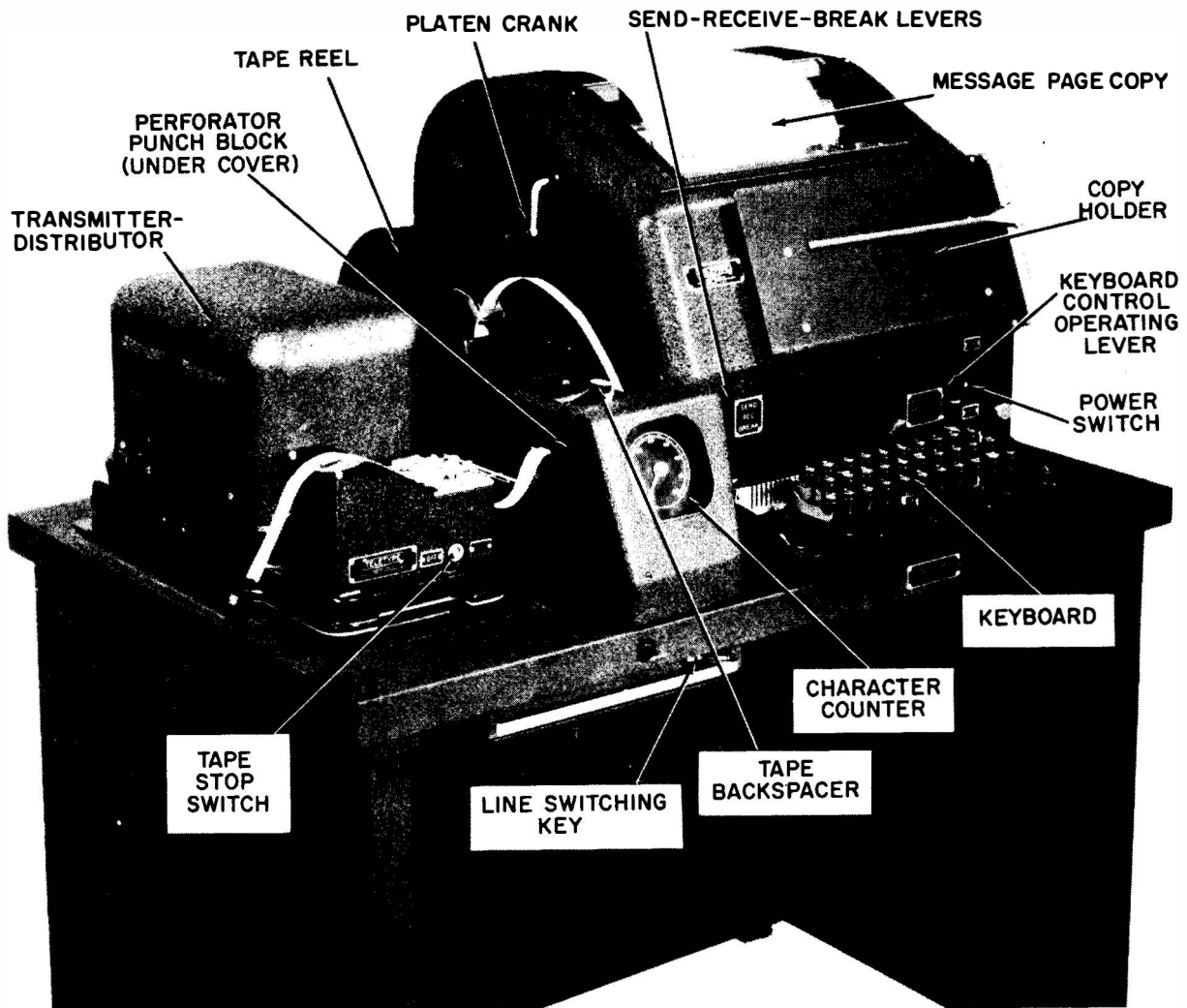

1.208

Figure 10-38.— Model 19 teletypewriter set.

### PACKAGE EQUIPMENTS

The volume of teletypewriter traffic relayed by NAVCOMMSTAS and many of the smaller shore stations has led to the development of tape relay equipment that requires a minimum of operator attention. At the top in figure 10-39 are receiving banks or console packages, which house several typing reperforators for use on incoming lines in torn-tape relay centers. The operator logs each incoming message, tears it off at the end of the message, and determines the proper outgoing circuit from the routing indicators on the tape. He then hand-carries each tape to the appropriate sending bank of automatic

transmitter distributors (bottom, fig. 10-39), and inserts it in the appropriate circuit tape grid (visible at tops of sending banks). The tape grid—sometimes called a washboard because of a certain similarity of appearance—is simply a place where tapes can remain during the period they are awaiting retransmission. They are stowed from top down in order of precedence. Other operators in attendance at the sending bank remove waiting tapes from the grid in order of precedence, and insert them in the TDs. A numbering TD applies a sequential channel number to each message, thus keeping a record of traffic relayed over each channel.

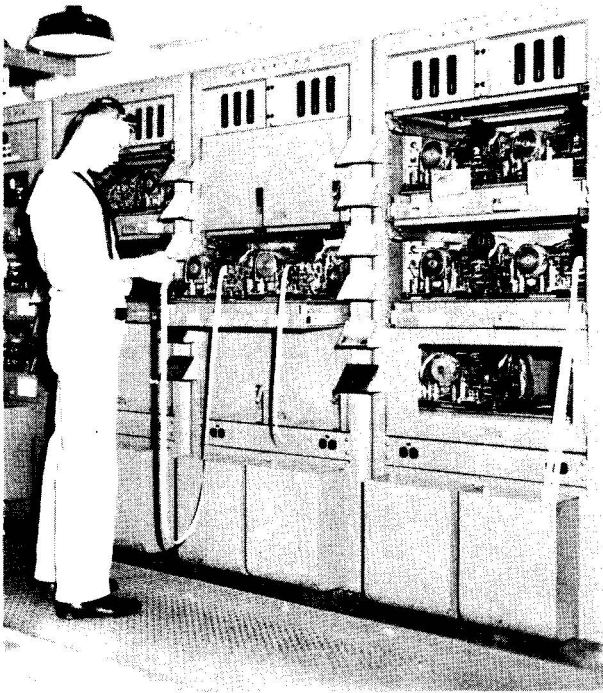

31.30

Figure 10-39.—Receiving and transmitting consoles at a torn-tape relay center.

If duplicate copies of relayed traffic are required for the files, monitoring equipment (not shown in fig. 10-39) is used. This is a group of typing reperforators that produces duplicates of tapes undergoing transmission on the sending bank, and winds the monitor tapes on reels suitable for stowage. The monitoring equipment also duplicates the channel number for each message, providing a means of reference if the message should be needed in the future.

#### FULLY AUTOMATIC RELAY EQUIPMENT

High-speed automatic relay centers are equipped with the very latest model 28 teletypewriter components. The transmitter distributors and reperforators are enclosed in cabinets that also contain the operating controls. Figure 10-40 shows the equipment layout at an automatic relay center. At left are the incoming line cabinets; outgoing line cabinets are at right. At center are the supervisor's control position and the miscellaneous intercept section. There are two reperforator-transmitters in each incoming cabinet. They slide out of the cabinet for easy replacement in event of failure. The reperforator-transmitters operate at a cross-office speed of 200 wpm. Therefore, messages are relayed from the incoming line cabinets to the outgoing line cabinets in a matter of seconds. When necessary, a third machine can be assigned to an outgoing circuit, to which high-precedence messages can be switched. The equipment is designed to "recognize" high-precedence tapes; a message in this "priority" machine causes its transmitter to take control of the line as soon



31.31

Figure 10-40.— Automatic relay center.

as any message in progress is transmitted. The transmitter retains control until it has processed all urgent messages awaiting transmission. Only then does control revert to the two regular machines.

Traffic volumes to be delivered to a given destination may often exceed the capacity of one outgoing-line channel. In such an event as many as 10 machines and 10 line channels may be shifted to serve a single destination.

All lines are duplex circuits; that is, any station can transmit a message to the relay center at the same time it is receiving a message. Each tributary station normally has two teletypewriters; one is a sending machine and the other a receiving-only teletypewriter.

Automatic relay centers are manned by very few operators, compared with semiautomatic torn-tape relay stations. Improperly prepared or garbled message tapes are routed automatically to the intercept position (fig. 10-41) for operator action. Correctly prepared messages enter and leave the relay center untouched by human operators.

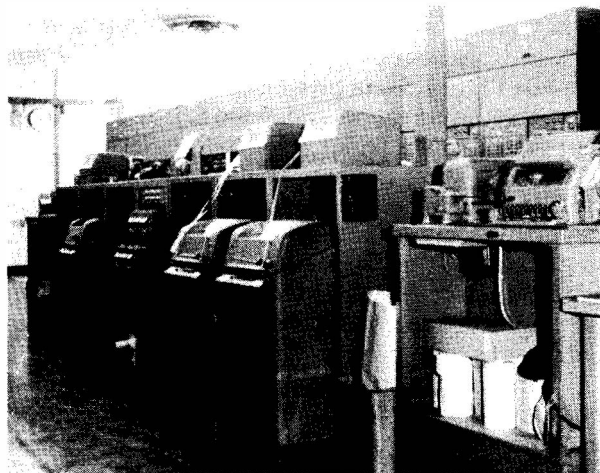

31.32  
Figure 10-41. —Intercept section of automatic relay center.

To reduce the frequency of supplying the perforators with fresh tape, the machines use a 3000-foot tape supply roll, instead of the usual 1000-foot roll.

#### ASSOCIATED EQUIPMENT

Teletypewriter communication systems require other associated equipment in addition to

the teletypewriters just discussed. Radio transmitters and receivers, such as those studied in chapter 9, are required for radioteletypewriter transmission and reception. Let us now get acquainted with the patch panels, keyers, converters, and other equipment necessary for RATT operation.

#### RECTIFIER POWER SUPPLY

Although teletypewriter motors operate on alternating current, a source of direct current is always required for the signal circuit carrying the start-stop code intelligence. Figure 10-42 shows one model rectifier power supply installed aboard ship to rectify alternating current, changing it to d-c for the operation of teletypewriters and converters. This rectifier furnishes a power output of 120 volts d-c at 1.0 ampere, which is enough to supply many teletypewriters operating simultaneously. The on-off switch, fuses, and voltage adjusting control are accessible through a door in the front of the cabinet.

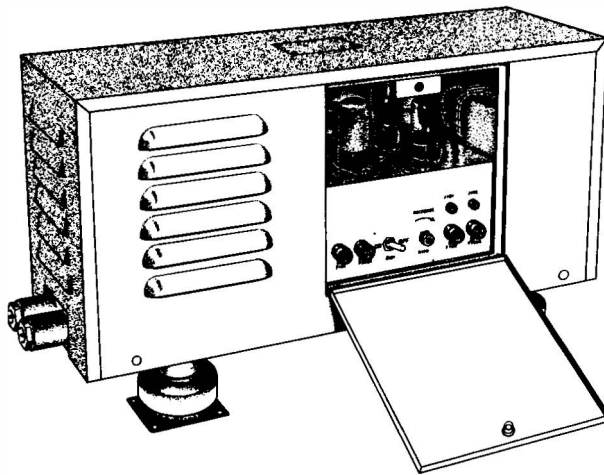

31.33  
Figure 10-42. —Rectifier power supply for teletypewriter operation.

#### TELETYPEWRITER PROJECTOR UNIT

Teletypewriter projector unit model TT-71 shown in figure 10-43, enables a teletypewriter message to be read simultaneously by groups of persons. It is installed in the pilot ready rooms in aircraft carriers and in teletypewriter conference rooms ashore.



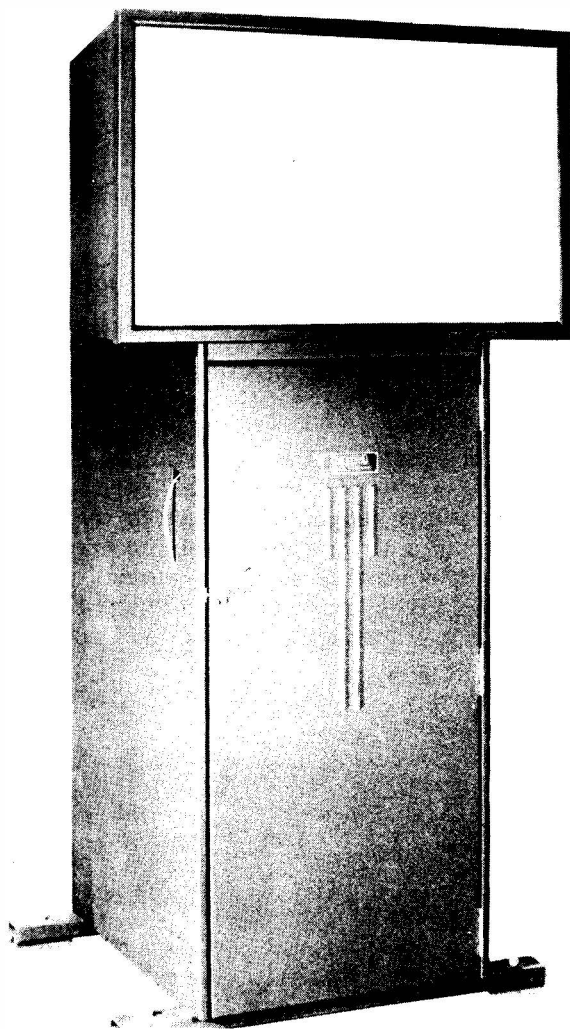

31.34

Figure 10-43. — Teletypewriter projector unit model TT-71.

The bottom of the cabinet houses a page printer. The message is printed on a roll of transparent cellophane. An optical lens system with a 1000-watt lamp enlarges the image of the teletypewriter message and projects it onto a tilted mirror at the top rear of the cabinet from where it is reflected onto the translucent screen. The message is visible along the lower edge of the screen as it is being printed. With each successive line feed the message advances upward on the screen one line at a time and finally moves out of view at the top. A tape typing unit provides a permanent typewritten record of transmissions in the projector unit, but at most

installations this feature is not used because a page copy from an additional printer patched into the same circuit has been found to provide a more readable and more convenient file copy.

The projector unit uses an ordinary teletypewriter ribbon. The cellophane roll is changed exactly as you would install a roll of paper in an ordinary printer, except that the loose end must be started on an automatic takeup spool. The optical unit is focused easily and does not often need refocusing.

The screen size limits the length of the typing line to approximately half the normal line length. You must remember this whenever you are typing material to be received on the projector unit. At most installations, the printer or perforating teletypewriter used for punching tapes for the projector has the end-of-line warning light and bell adjusted to warn you of this shortened line length.

#### TELETYPE PANELS

Teletype panels SB-1203/UG and SB-1210/UGQ, shown in figure 10-44, are used for interconnection and transfer of teletypewriter equipment aboard ship with various radio adapters, such as frequency shift keyers and converters. The SB-1210/UGQ is intended for use with cryptographic devices, whereas the SB-1203/UG is a general-purpose panel.

Each of the panels contains six channels, with each channel comprising a looping series circuit of looping jacks, set jacks, and a rheostat for adjusting line current. The number of looping and set jacks in each channel varies with the panel model. Each panel includes a meter and rotary selector switch for measuring the line current in any channel. There are six miscellaneous jacks to which may be connected any teletypewriter equipment not regularly assigned to a channel.

To operate either of the teletype panels:

1. Turn all line current rheostats counterclockwise to increase circuit resistance to maximum value.

2. Turn on the local line current supply at the rectifier unit and at the distribution panel (not shown in the illustration). The green indicator light on the model SB-1203/UG panel will come on.

3. If the desired teletype equipment is wired in the same looping channel as the radio adapter (keyer or converter) to be used, no patch cords are required.

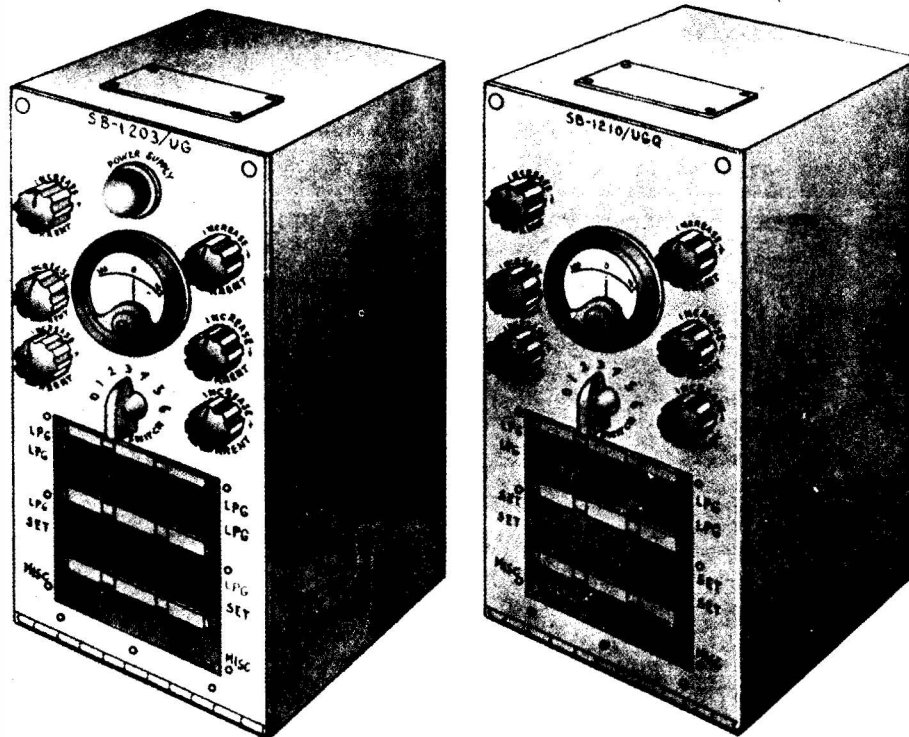

70. 79(76)

Figure 10-44.— Teletype patch panels SB-1203/UG and SB-1210/UGQ.

4. Turn the meter selector switch to the desired channel and adjust the corresponding rheostat to give a line current indication of 60 milliamperes.

5. If the desired teletypewriter (for example, in channel 1) is not wired in the same looping channel as the keyer or converter to be used (for example, channel 3), insert one end of a molded patch cord (supplied with panel) in the set jack in channel 1, and the other end in either one of the two looping jacks in channel 3.

In any switching operation between the various plugs and jacks of a teletype panel, remember to never pull the patch plug from the machine (set) jack before first removing the other end of the cord plug from the loop jack. Pulling the plug from the set jack first will open-circuit the channel and cause all teletype messages in the channel to be interrupted. The proper procedure is to take the plug out of the looping jack first, and to insert it last. This action maintains closed-circuit operation of all channels in the panel at all times.

#### TONE-SHIFT KEYER/CONVERTER

Tone-shift keyer/converter model AN/SGC-1A is used for short-range RATT operation. Normally it is used for communication on UHF and VHF bands, but it can be used with any transmitter designed for voice modulation. The AN/SGC-1A is shown in figure 10-45, with blocks to indicate other equipment necessary for a complete tone-shift system.

In tone modulation transmission, the teletypewriter pulses are converted into corresponding audio tones, which amplitude modulate the transmitter. Conversion of the audio tones is accomplished by an audio oscillator in the tone converter, which operates at 700 cycles when the teletype loop is in a closed-circuit (mark) condition and at 500 cycles when the loop is in an open-circuit (space) condition.

An internal relay closes a control line to the radio transmitter, which places the transmitter on the air when the operator begins typing a

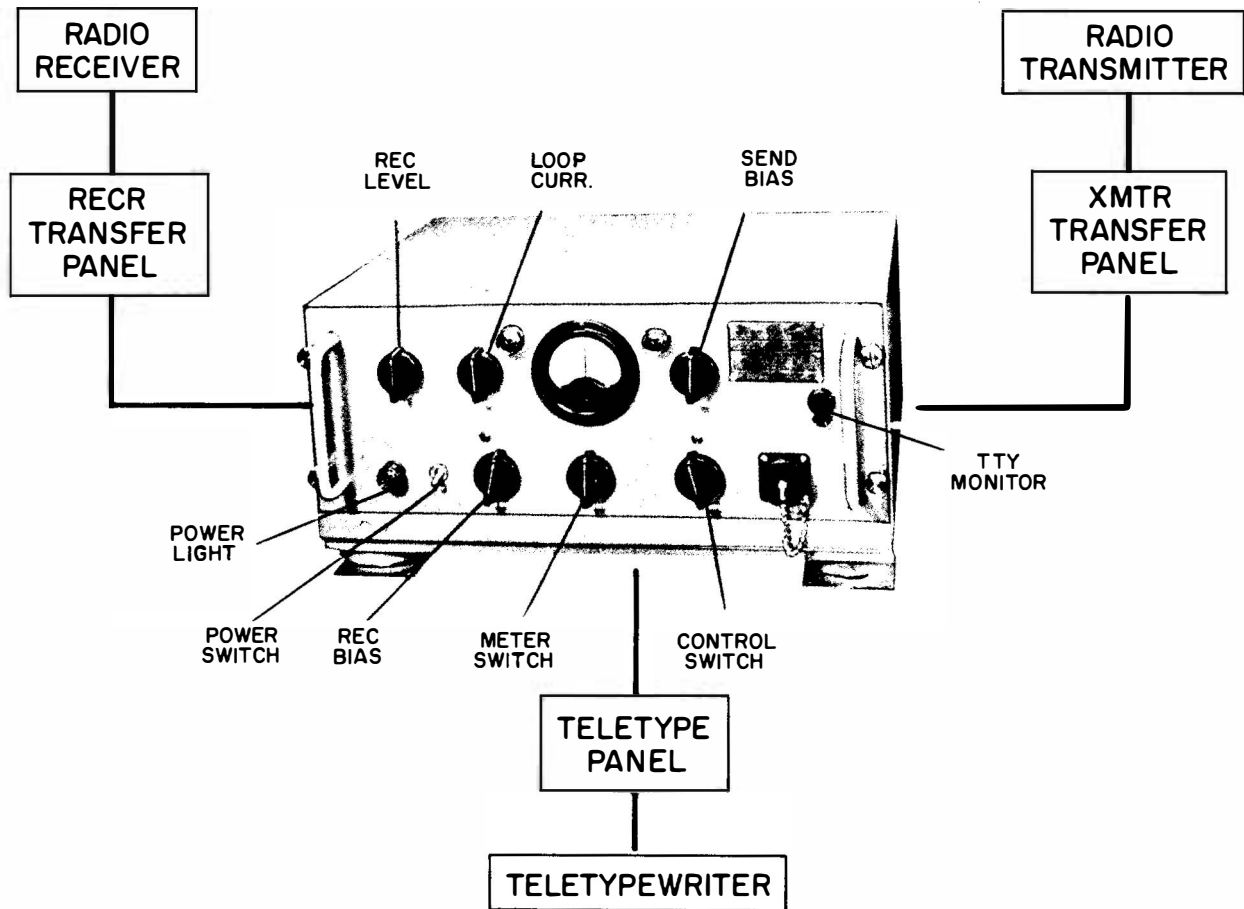

Figure 10-45.— Tone-shift keyer/converter AN/SGC-1A. 1. 240

message. The control line remains closed until after the message is transmitted.

When receiving messages, the tone converter accepts the mark and space tones coming in from the radio receiver and converts the intelligence of the tones to the make and break contacts of a relay connected in the local teletypewriter loop circuit. This action causes the local teletypewriter to print in unison with the mark and space signals from the distant teletypewriter.

The receive level control, located at the upper left on the front panel, permits adjustment of the level of the incoming tone signals from the receiver. The loop current rheostat is next to the receive level control, and is adjusted to 60 milliamperes when the teletype loop is in the mark, or closed, circuit condition. A meter and its switch permit measurements to be taken in all the important portions of the circuit.

Two indicator lights flank the upper part of the meter. One light (green) indicates the receive condition and the other (red) indicates the transmit condition. Both lights are off when the keyer/converter is in the standby condition.

The send bias rheostat is located at the right of the meter. It permits correction of teletype distortion (for example, unequal length of mark and space signals) in the local teletypewriter loop when sending a message.

At the far right is a jack marked TTY MONITOR. A monitoring teletypewriter may be patched into this jack, thereby placing it in series with all other teletypewriters in the loop.

The power indicator light is located at the lower left side of the front panel. The ON-OFF switch is located next to it.

The receive bias control is located at the right of the power switch. This control enables correction of distortion in the receiving tone circuit.

The control switch, located at the right of the meter switch, permits the keyer/converter to function in several ways. When the switch is on AUTO (automatic), the equipment may be in one of three conditions: receiving, transmitting, or standby. When in the standby condition, the reception of an incoming mark tone causes the control circuit to change to receiving. Following the end of the incoming message, the circuits shift back to standby. When in the standby condition, the operation of the local teletypewriter causes the circuits to change to transmit. After the last letter is keyed, there is a time delay of about 3 seconds and then the circuits shift back to standby. These interlocking functions prevent the equipment from shifting directly from transmit to receive, or vice versa. Thus an incoming signal will not interrupt an outgoing signal nor will keying the local teletypewriter, when receiving, cause the circuit to shift to transmit. The normal method of operation is with the control switch in AUTO position. After a station has completed sending its message, it is ready for reception of any return message after a 3-second time delay.

The control switch position marked TRS is useful when making initial adjustments but is not used in carrying on communications because it locks the equipment in the transmit condition and makes it impossible to receive any message.

The REC/STDBY position of the control switch prevents the equipment from changing to the transmit condition even though the teletypewriter is operated, but it can receive messages or remain in the standby condition.

The fourth position of the control switch is ADJ FREQ. This position is for maintenance use only, and is not used during operating periods.

Because a small time delay is incurred in the operation of the control circuits of the local and distant terminals, the first character transmitted is usually lost. The normal 5 spaces,

2 carriage returns, and line feed functions used at the beginning of each message are more than adequate to compensate for this first-character loss.

## FREQUENCY-SHIFT KEYER

For frequency-shift RATT transmission, a keyer is needed to replace the oscillator of a CW transmitter with a source of radiofrequency excitation that can be shifted a small amount upward and downward to produce RATT signals corresponding to the mark-space teletypewriter code. Such a frequency-shift keyer is model KY-75/SRT shown in figure 10-46.

During frequency-shift keying operation, the frequency of the transmitter's carrier appears at a certain frequency during a SPACE signal and shifts a few hundred cycles higher for a MARK signal. The amount of this frequency-shift deviation of the keyer is adjustable over a range from 0 to 1000 cycles per second. Usually, the keyer is adjusted for an 850-cycle shift, which means that the MARK signal is 425 cycles above the carrier frequency, but the SPACE signal is 425 cycles below the carrier.

The procedure for setting up the keyer and transmitter for frequency-shift transmission is that of adjusting the crystal oscillator and tuned circuits of the keyer to the desired crystal frequency. A signal from the teletypewriter is then applied to the keyer where it is frequency modulated and then coupled to the transmitter where it is multiplied to the channel frequency.

The KY-75/SRT keyer is used also for facsimile transmission. Newer models of Navy transmitters, such as the AN/SRT-15 described in chapter 9, have built-in keying circuits for frequency-shift mode of operation and do not require an external keyer for either RATT or facsimile transmission.

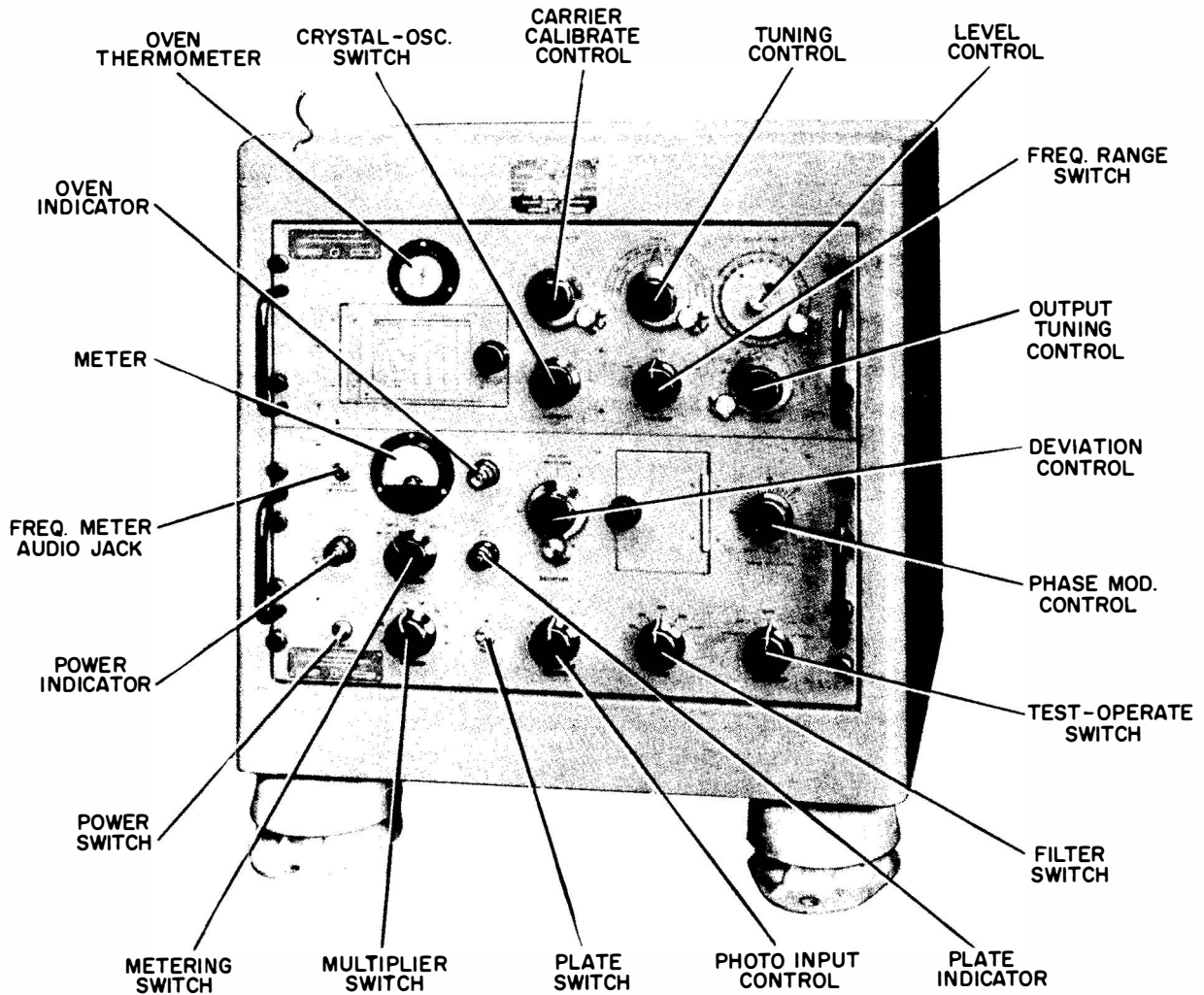

31.35

Figure 10-46. — Frequency-shift keyer KY-75/SRT.

### CONVERTER-COMPARATOR GROUPS

The AN/URA-8B frequency-shift converter-comparator group, shown in figure 10-47, is used for diversity reception of RATT and FAX signals. The equipment consists of two frequency-shift converters (top and bottom units) and a comparator (middle unit).

For either space diversity or frequency diversity reception, two standard Navy receivers are employed in conjunction with the converter-comparator group. In space diversity operation, the two receivers are tuned to the same carrier frequency, but their receiving antennas are spaced several wavelengths apart. Because of the required spacing between antennas, space diversity usually is limited to shore station use.

In frequency diversity operation, the two receivers are tuned to different carrier frequencies that are carrying identical intelligence. Frequency diversity reception commonly is used aboard ship for copying fleet broadcasts, which are keyed simultaneously on several frequencies.

In diversity reception, the audio output of each receiver is connected to its associated frequency-shift converter which converts the frequency-shift characters into d-c pulses. The d-c (or mark-space) pulses from each converter are fed to the comparator. In the comparator, an automatic circuit compares the pulses and selects the better mark and the better space pulse for each character. The output of the comparator is patched to the teletypewriter. The converter

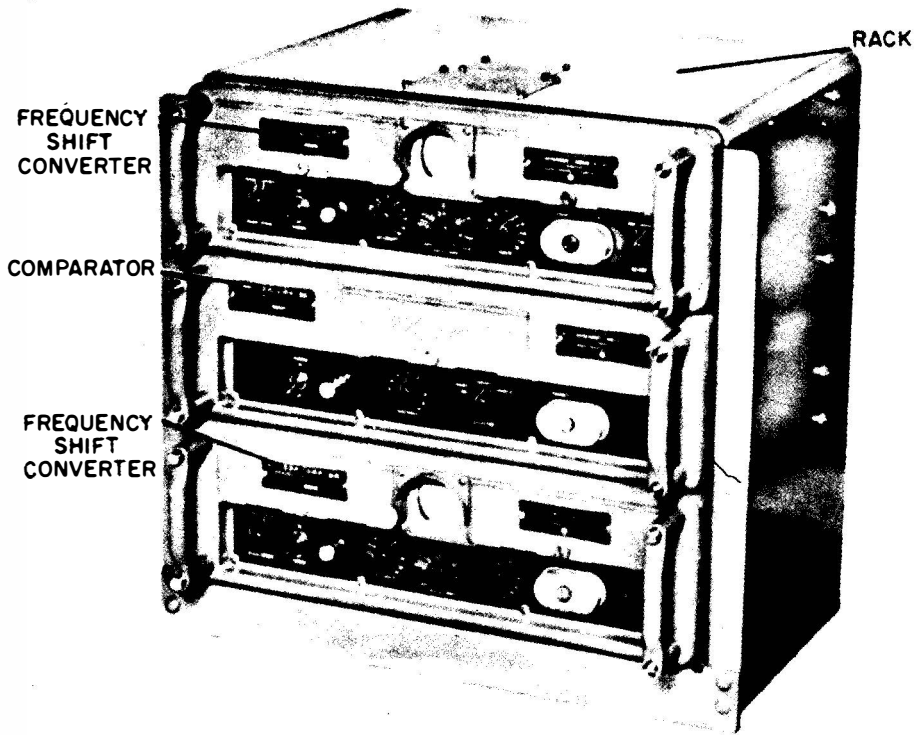

1.235

Figure 10-47.— Frequency-shift converter-comparator group AN/URA-8B.

units also can be used individually with separate teletypewriters to copy two different FSK signals.

The newest converter-comparator group is the AN/URA-17 shown in figure 10-48. This is a completely transistorized equipment designed to perform the same functions as the AN/URA-8B. Although present procurement of frequency-shift converters is confined to the AN/URA-17, there are relatively few installations compared with the larger number of AN/URA-8B converters.

The AN/URA-17 consists of two identical converter units. Each converter has its own comparator circuitry. Hence, a separate comparator unit is not required. The physical size of the AN/URA-17 is further reduced by using transistors and printed circuit boards. The complete equipment is less than half the size of the older AN/URA-8B.

Proper tuning of the receivers employed with these converter-comparator groups is of the utmost importance. Each converter has a small monitor oscilloscope that gives a visual

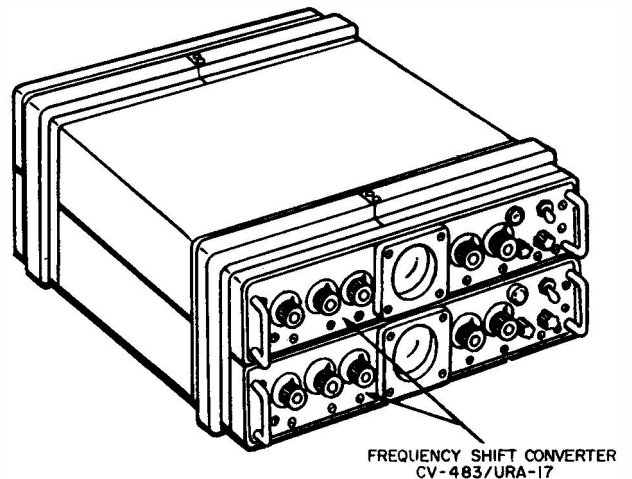

50.766

Figure 10-48.— Converter-comparator group AN/URA-17.

indication of the receiver tuning. The scope patterns for correct and incorrect tuning are shown in figure 10-49.

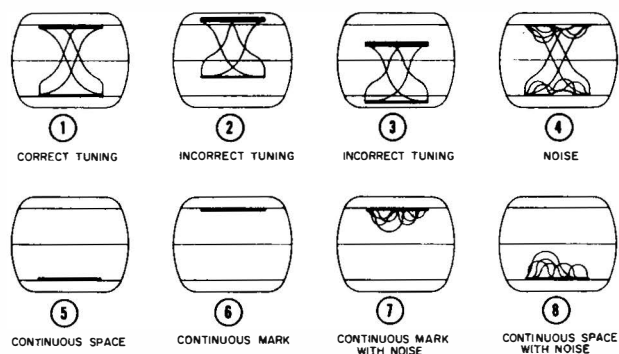

1. 239.3

Figure 10-49.—Monitor oscilloscope patterns for frequency-shift converters.

Detailed instruction for operating the AN/URA-8B and the AN/URA-17 are contained in their respective technical manuals.

#### TRANSMITTER TELETYPEWRITER CONTROL UNIT

Another piece of equipment used with teletypewriter installations aboard ship is the control unit shown in figure 10-50. This unit is mounted close to the teletypewriter keyboard and permits remote control of the radio transmitter. It has a transmitter power on-off switch, a power-on indicator lamp, a carrier-on indicator lamp, and a three-position rotary selector switch.

The TONE S/R switch position is used for both sending and receiving when using tone-shift keyer/converter AN/SGC-1A. When using carrier-frequency shift mode of operation, the operator must switch to CFS SEND position for transmitting, and to CFS REC position for receiving.

#### ELECTRONIC MULTIPLEX TERMINAL SET

Model AN/FGC-5 (fig. 10-51) is a send-receive electronic time-division multiplex terminal set used chiefly for teletypewriter communications over long-range, high-frequency radio circuits using frequency shift keying.

Time-division MUX (multiplex) is the transmission of the intelligence of several teletypewriter circuits on a time-sharing basis in a character-by-character sequence. Teletype-

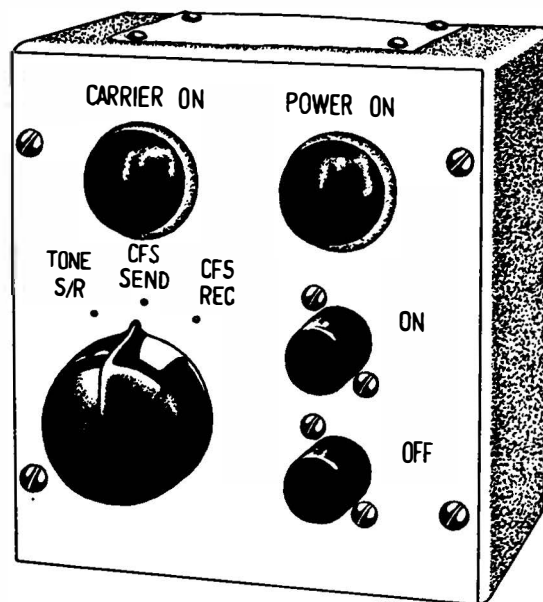

1. 244.1

Figure 10-50.— Transmitter teletypewriter control unit.

writer signals can be fed into the MUX equipment simultaneously from two, three, or four teletypewriters. The same information is then transmitted from one MUX equipment to the receiving group at the distant station in a time sequence with one character from each channel at a time. The receiving MUX then distributes the information to the proper teletypewriter circuits in their original on-off direct-current form. Up to four characters are therefore transmitted over a single circuit during the time ordinarily required by one.

As shown in figure 10-51, AN/FGC-5 consists of two equipments, the telegraph transmitting group and the telegraph receiving group. These terminal equipments do not however, take the place of the radio transmitter and receiver. The transmitter and receiver still are required as in any other methods of RATT transmission and reception. You may think of the AN/FGC-5 transmitting group as the keyer, and the receiving group as the converter in the simpler RATT systems described previously.

The operating speed of all teletypewriters used with the MUX set must be identical so that both terminals of the system can cycle in synchronism. Normally, 60-wpm channel speed is used, although the units and the teletypewriters can be changed to operate at 75 wpm.

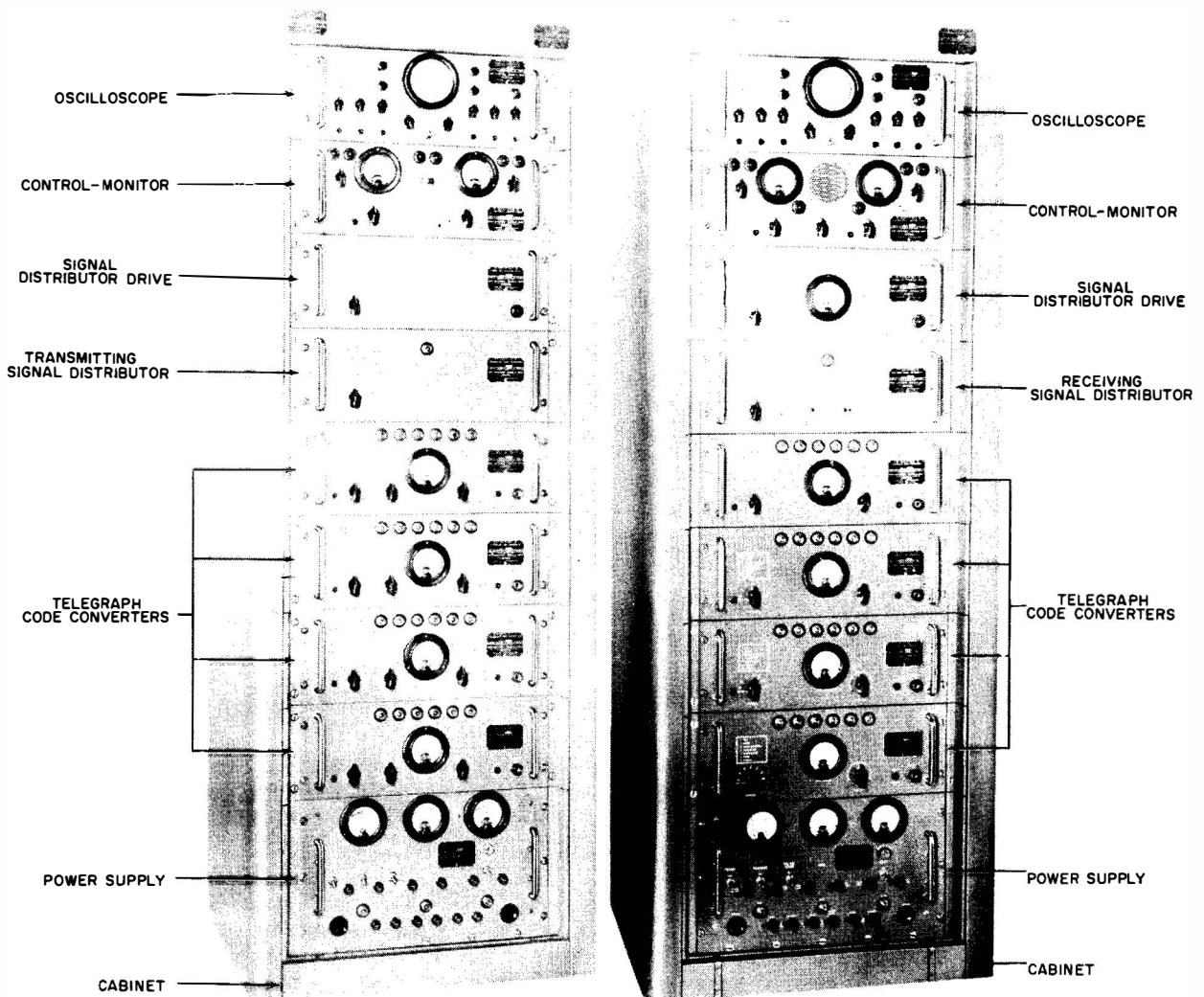

Figure 10-51.— Electronic multiplex telegraph terminal set AN/FGC-5. 31.36

A newer telegraph terminal set is model AN/UGC-1 (fig. 10-52). It is a completely transistorized version of the AN/FGC-5. The receiver group, transmitter group, and a common power supply are all housed in a single cabinet only 36 inches high. It is only one-fourth the size of the complete AN/FGC-5 equipment, with which it is operationally compatible. The AN/UGC-1 offers a choice of 3 system channel speeds: 60, 75, or 100 wpm per channel, and either 2, 3, or 4 channels of operation, depending on traffic requirements and radio propagation conditions.

A recently developed transistorized telegraph terminal set designed for 100 wpm, single side-

band operation is the AN/UCC-1 (not illustrated). Multiplexing is accomplished by frequency division. The equipment has the capability of 16 narrow-band channels or 8 narrow-band channels and 4 narrow-to-wide-band channels, in the frequency range of 300 to 3300 cps. Spacing between channels is 170 cps.

#### RATT SYSTEMS AFLOAT

Let us now see how the various pieces of equipment—teletypewriters, keyers, converters, receivers, and transmitters—are combined into complete RATT systems. The Navy uses two



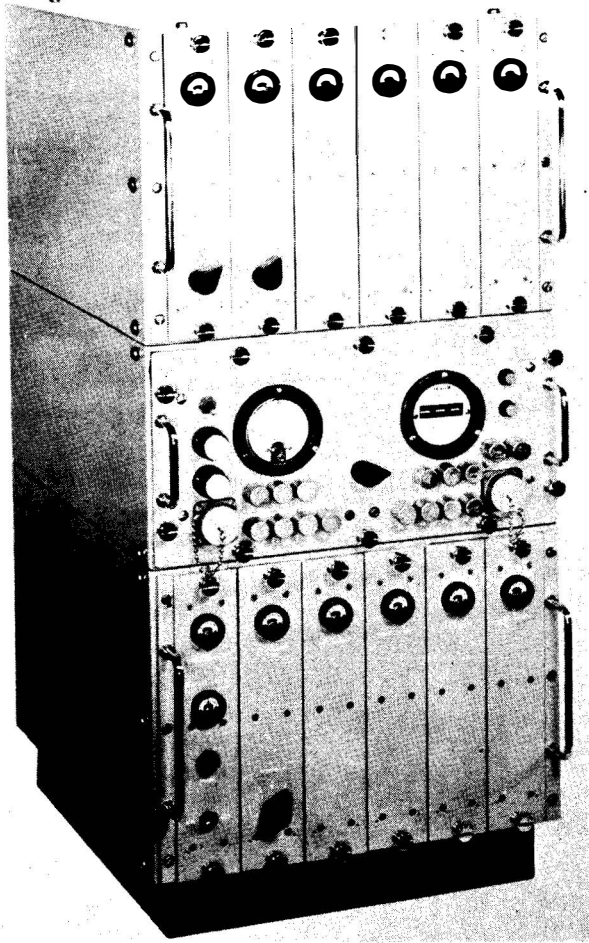

31. 37

Figure 10-52.— Transistorized electronic multiplex telegraph terminal set AN/UGC-1.

basic RATT systems aboard ship. One, the TONE-MODULATED SYSTEM for short-range operation, is similar to the familiar a-m radio. The other, the CARRIER-FREQUENCY-SHIFT SYSTEM for long-range operations, is similar to the standard f-m radio. The two systems are shown integrated in figure 10-53.

The page printer—model 15 or 28—sends out a continuity of d-c on-and-off pulses (timed intervals of current and no-current). These intervals are, as you know, mark and space impulses, and various combinations represent the various characters being transmitted.

When two teletypewriters are wire-connected, the exchange of intelligence between them is direct. But when the teletypewriters are not

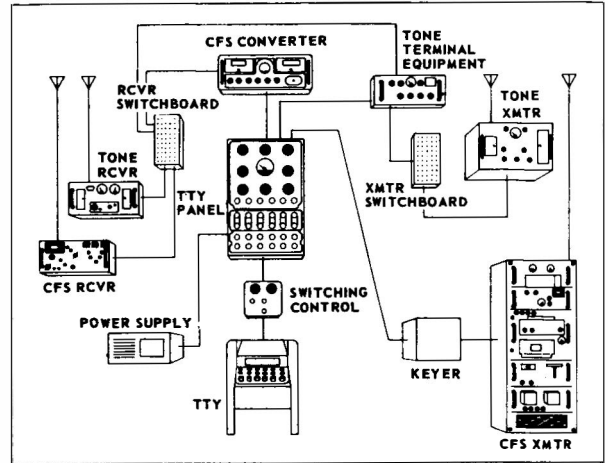

1. 225

Figure 10-53.— Basic RATT transmit-receive systems.

joined by wire, operation is more complex. Direct-current mark and space intervals cannot be sent through the air.

The gap between the machines must be bridged by radio. To bridge the gap, a radio transmitter and receiver are needed. The transmitter produces a radiofrequency carrier wave to carry the mark and space intelligence. Also, a device such as a KEYER is needed to change the d-c pulses from the teletypewriter into corresponding mark and space modulation for the carrier wave in the transmitter. The radio receiver and a CONVERTER are required to change the radio-frequency signal back to d-c pulses.

Figure 10-54 shows a modulated carrier wave with audio tone impulses impressed on the radio-frequency carrier wave, with corresponding d-c mark and space signals.

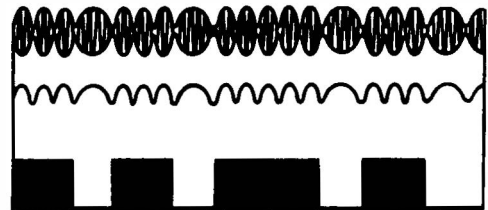

1. 227

Figure 10-54.— Modulated carrier wave with corresponding audio tone for mark and space electrical impulses.

Figure 10-55 shows a carrier-frequency-shift wave that increases and decreases to denote mark and space d-c impulses.

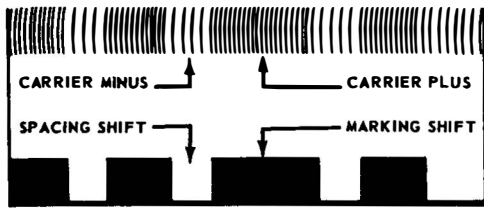

1. 227

Figure 10-55.— Frequency of the carrier wave increases and decreases corresponding to mark and space impulses.

In the operations shown in figures 10-54 and 10-55, the d-c teletypewriter signal that can travel only by wire becomes, through the medium of a tone terminal or keyer unit, either a tone-modulated signal or a carrier-frequency-shift signal for radio carrier wave transmission.

### SHORT-RANGE SYSTEM

To transmit messages by the short-range system, a page printer, a tone terminal, and a transmitter are used. The printer sends out a d-c signal. The signal is changed to audio tones in the tone terminal. The transmitter impresses the audio tones on the carrier and sends out a tone-modulated carrier wave (fig. 10-56).

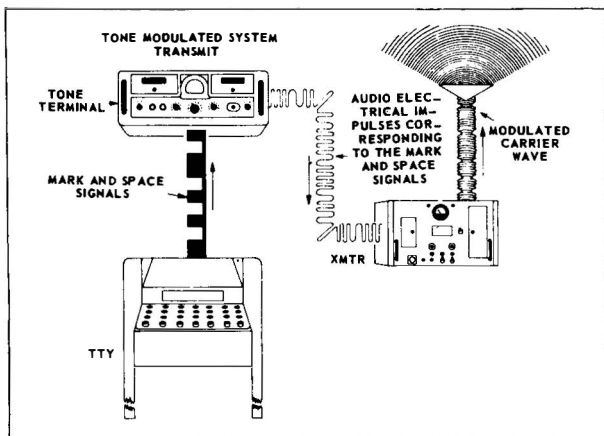

1. 228

Figure 10-56.— D-C mark and space impulses converted to audio tones and impressed on carrier wave.

To receive messages with the short-range system, a radio receiver, a tone converter, and a page printer are required. The tone-modulated carrier wave enters the receiver, which extracts the signal intelligence and sends the audio tones to the tone converter. The converter changes the audio tones into d-c mark and space pulses for the page printer (fig. 10-57).

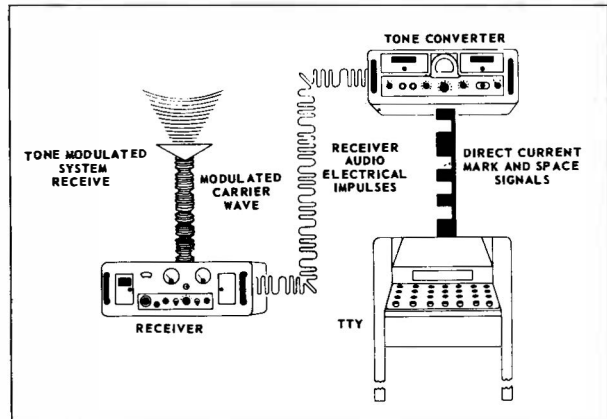

1. 229

Figure 10-57.— Receiving operation of the tone converter.

In practice, the same tone terminal is used for the receiving and the sending circuits inasmuch as it contains both a transmit "keyer" unit and a receive "converter" unit.

### LONG-RANGE SYSTEM

At the transmitting end of the long-range system are a page printer, a transmitter, and a frequency-shift keyer unit. The keyer unit is built into the newer transmitters, but in some older systems it is a separate piece of equipment. When the page printer is operated, the d-c mark and space signals are changed by the keyer unit into frequency-shift intervals. The frequency-shift intervals are transmitted as carrier-frequency-shift signals (fig. 10-58).

On the receiving side of the long-range system are a receiver, a frequency-shift converter, and a page printer. When the carrier-frequency-shift signal enters the receiver, it is detected and changed into a corresponding frequency-shifted audio signal. The audio output of the receiver is fed to the converter, which changes the frequency-shifted audio signal into d-c mark and space signals (fig. 10-59).

TAPE READING

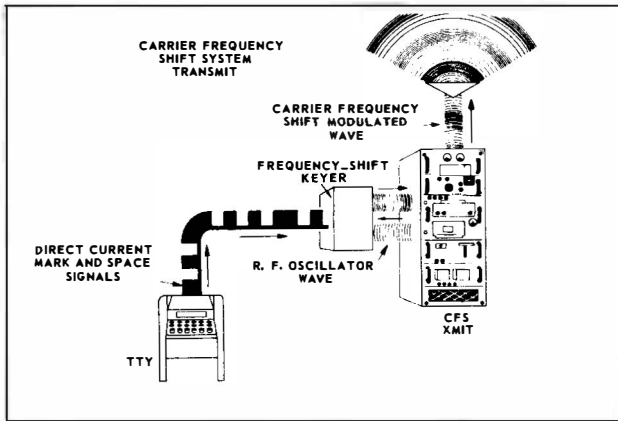

1. 230

Figure 10-58.— D-C mark and space impulses are changed by the keyer unit into frequency-shift intervals.

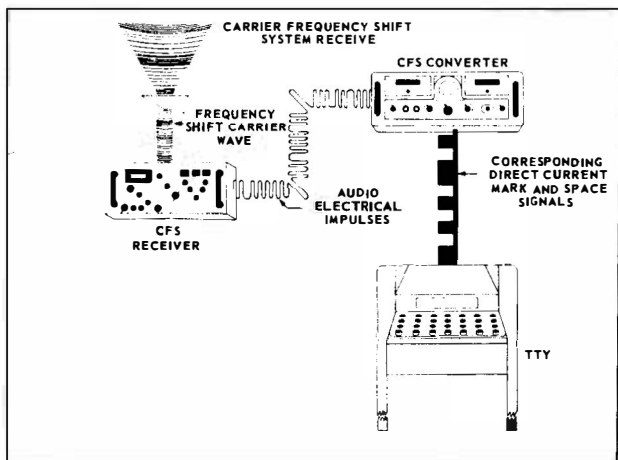

1. 231

Figure 10-59.— Conversion of frequency-shifted carrier wave into mark and space impulses.

In both the tone-modulated system and the carrier-frequency-shift system, all teletypewriter signals pass through the teletypewriter panel that controls the looping current in all the circuits. The teletypewriter panel integrates the tone-modulated and the carrier-frequency-shift systems. It provides every possible RATT interconnection available on board ship. This operational flexibility gives maximum efficiency with the fewest circuits and the least amount of equipment in the Navy's compact RATT systems afloat.

In order to read perforated tape, you must understand arrangement of code positions. The code is a five-unit mark-space signaling code arranged vertically on the tape, from the No. 1 position at the top to the No. 5 position at the bottom. A hole is a mark; no hole is a space. Between the second and third positions is a tape feed perforation (TRACK) that is smaller than the code perforation (see fig. 10-60). This smaller perforation fits over the tape feed wheel that moves the tape through the transmitter-distributor, and is NOT a part of the code. The upper side of chad tape usually has a slight roughness made by the hole-punching pins. Read the tape with this side uppermost. Use the track as a visual guide. Remember, no more than two perforations will appear above the track, nor more than three below. In figure 10-60 the positions are numbered from 1 to 5. This is for study purposes: don't expect these numbers to appear on an actual tape.

The LTRS code contains perforations in all five positions. Codes besides LTRS and BLANK contain perforations in different combinations of positions. For instance, A is 1-2, B is 1-4-5, and C is 2-3-4.

Read the perforations in lowercase until a FIGS code appears. Following a FIGS code read the tape as uppercase until a LTRS code appears, after which read as lowercase again. On circuits on which machines unshift on spacing, read codes in lowercase following the space code.

Memorize several codes at a time, learning the uppercase characters for each. Perforate strips of tape and read the codes you have memorized. Association of memory and eye will help you recognize codes quickly and will build reading speed.

The discussion and illustrations following provide a study plan for learning the code. Begin by learning the 1-HOLE codes: E, LF, SPACE, CAR RET, and T (fig. 10-61). Letter E is perforated in the No. 1 position, and the remainder of the positions are blank. LINE FEED is one perforation in the No. 2 position—and so forth, down to T, which is perforated in the No. 5 place. Keep this pattern in mind. Perforate these codes several times on a tape to help remember them.

Your next group is of three key letters: A, O, and N.

Check figure 10-62. The letter A is represented by two holes above the track. This pattern—two holes above the track—is

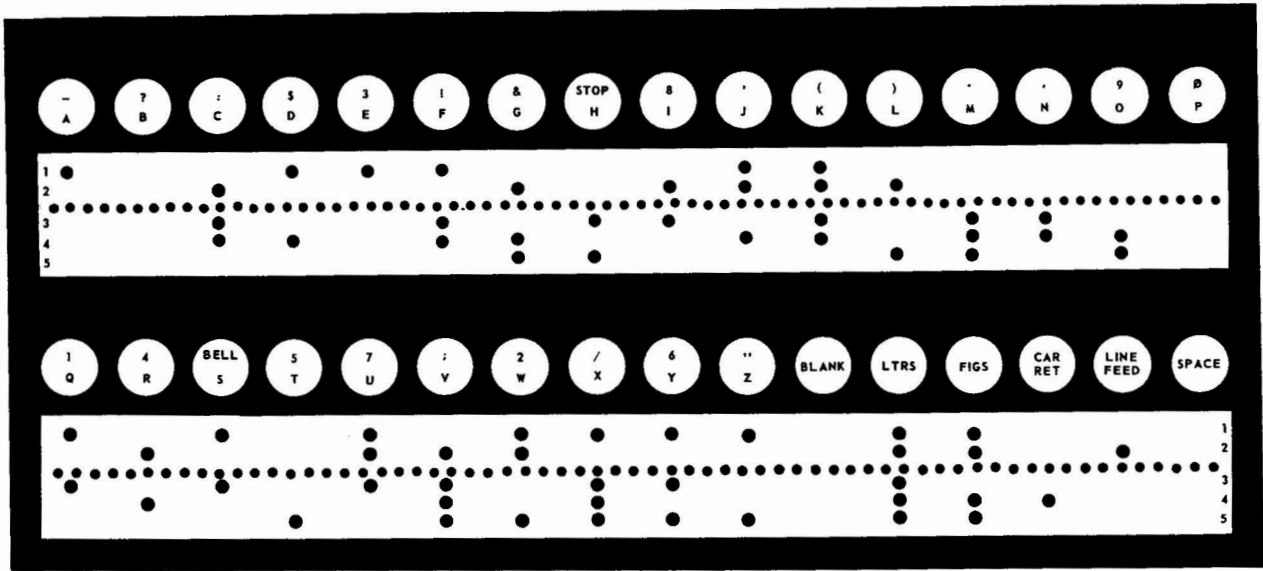

31.38

Figure 10-60.— The 5-unit teletypewriter code.



31.39

Figure 10-61.—The 1-hole codes: E, LF, SPACE, CAR RET, and T.

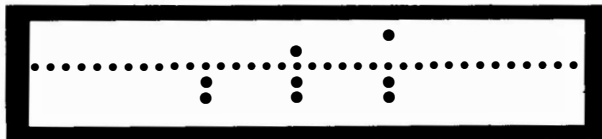

31.40

Figure 10-62.— Letters A, U, J, and W.

also characteristic of U, J, and W; read DOWN to find which. In the same way (fig. 10-63) O is

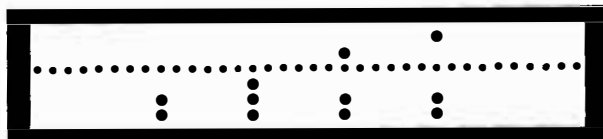

31.41

Figure 10-63.— Letters O, M, G, and B.

common to M, G, and B, but this time read UP to get the associated codes. The final letter of this series is N (fig. 10-64), which you read up for C and F.

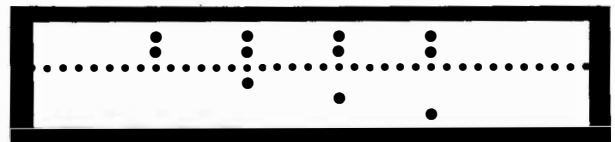

31.42

Figure 10-64.— Letters N, C, and F.

With this much information mastered, get plenty of practice before learning more letters. Perforate the codes and, as your reading improves, mix them to make the reading more difficult. Emphasize ACCURACY, not speed. If you haven't the opportunity to work with a perforator, draw the codes on 3x5 cards (with answers on back) and scramble them.

You can learn three more sets of letters by using the track line for a guide. Read letter I (one hole above and one below the track line) and retain it as a reference point for reading D or Z (fig. 10-65). Learn R and use it to read L; learn Y and read P (fig. 10-66).

Eight letters that you can master by remembering them as opposites are Q and X, V and K, H and S, E and T (figs. 10-67 and 10-68). Letters E and T, remember, are also among the one-hole codes.

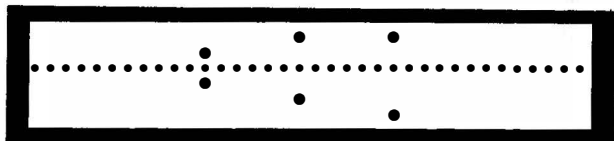

31.43  
Figure 10-65.— Letters I, D, and Z.

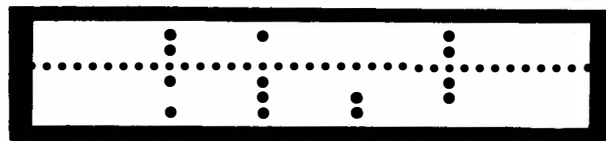

31.45  
Figure 10-67.— Letters Q and X; V and K.

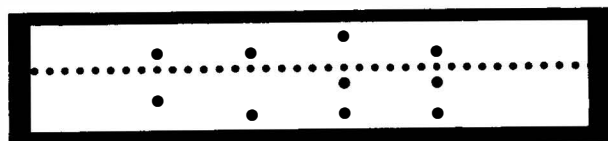

31.44  
Figure 10-66.— Letters R and L; Y and P.

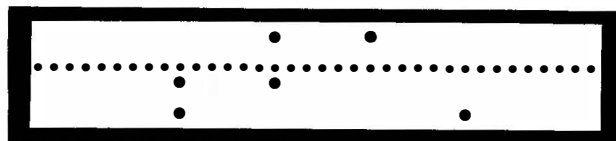

31.46  
Figure 10-68.— Letters H and S; E and T.

Two keys you will use a great deal are LTRS and FIGS, which shift your machine into lowercase and uppercase. The LTRS code is easy to recognize because it is the only one with five

perforations. The FIGS code resembles it in that there are two perforations above the track, and two below, with only the No. 3 position blank.