

BASICS of RADIO ASTRONOMY

(by Flavio Falcinelli)
November 2019

INDEX

1. Introduction	p. 3
2. Some history	p. 6
3. What does a radio telescope measure?	p. 7
4. The screen of the Earth's atmosphere	p. 9
5. Does it make sense to talk about amateur radio astronomy?	p. 11
6. How, what and where to look	p. 12
7. What future expansions are imaginable with RAL10?	p. 17
8. The radio telescope becomes a measuring instrument	p. 20
9. Radiometer or radio-spectrometer?	p. 21
10. Radio observation of meteoric events	p. 24
11. The "special" frequency of the Hydrogen	p. 40
12. The "magic" band 1400-1600 MHz and the SETI researches	p. 45

VISIT OUR BLOG

<http://blog.radioastrolab.com/>

TO KEEP UPDATED!

1. Introduction

LOOK AT THE SKY WITH DIFFERENT EYES

We can observe the sky in many ways: the view is always wonderful, fascinating and exciting. You will be astonished contemplating the stars on a clear winter night, away from city lights, the wonder increases observing the details of the moon with binoculars or the planets with a telescope.

These tools, which amplify our visual possibilities, are familiar: who has never had the pleasure of getting close to a telescope's ocular during an educational evening held by the local group of astronomers? However, not everyone knows that there are other ways to look at the sky, no less fascinating than the visual.

We live in a sea of electromagnetic waves generated by the technology (mobile phones, wireless devices, and television repeaters...) and from the natural world, with radiation that come from extra-terrestrial space. Every celestial object, from the planets to the farthest galaxies, emit electromagnetic waves: from gamma rays to X-rays, ultra-violet and visible radiation, up to infrared and radio emissions. The human being perceives the emissions in the band of visible because Mother Nature has equipped us with the sense of sight, essential for living, but to "see" other "windows" of the electromagnetic spectrum different tools are needed, each specialized to measure radiation in a certain band frequencies.

Radio astronomy studies the sky by analyzing the natural radio waves emitted by celestial objects: any object, if not only for its temperature, radiates measurable electromagnetic waves which generally show the incoherent characteristics of a broad spectrum noise.

In general, by *radio source* is indicated any source of radio waves: in common use the term has become synonymous with the *cosmic sources* of radio waves.

Radio telescopes, instruments that record the faint radio stream coming from outer space, include an antenna system, transmission lines and a receiver: the electronics amplifies the signal received by the antenna to make it measurable. There follow the devices for processing and recording of the information, in addition to organs for the instrument control and the antenna direction.

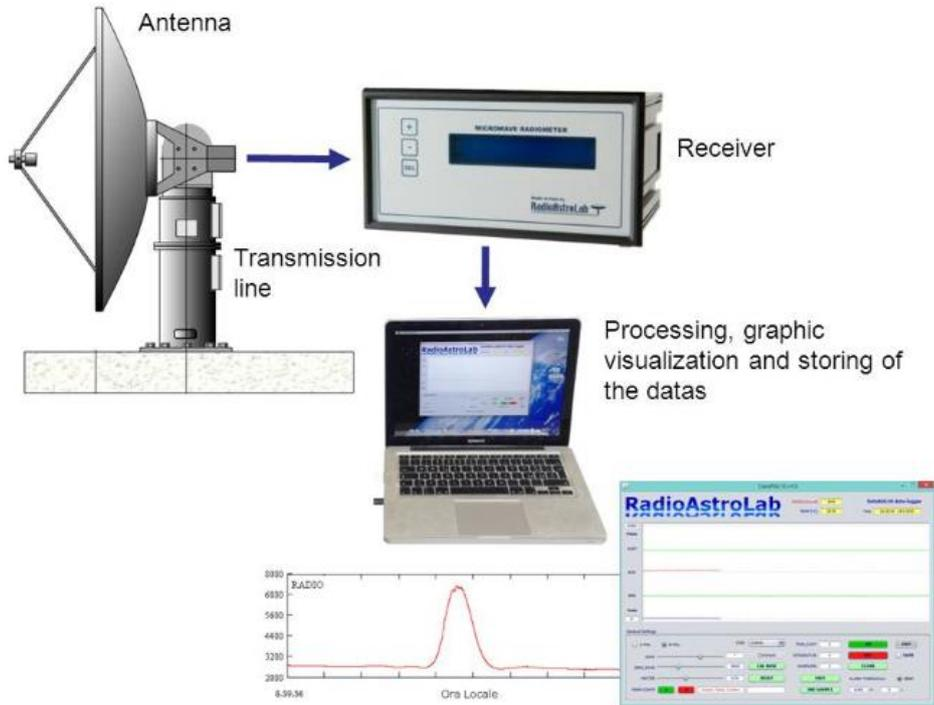

Undoubtedly it is not trivial to capture the radio of a distant galaxy: the signals are very weak, choked by artificial interference from background noise. To be successful you need a minimum of learning, passion and tenacity. But isn't it true for any activity?

THE HISTORY OF AMATEUR RADIO ASTRONOMY: OUR HISTORY

We were the first Italian company to offer on the market, in 2000, the RAL10 receiver along with the information needed to build and use an amateur radio telescope.

RADIOMETRICA
 Copyright © Salvatore Pluchino (salvo_pluchino@isp.it)
 ALL RIGHTS RESERVED

RAL10
 10-12 GHz
 Total-Power
 Microwave Radiometer

Economic and designed to take advantage of commercial elements for the reception of satellite TV, RAL10 started many fans to radio astronomy. Students, amateur astronomers, radio amateurs, schools and universities, have built their small radio telescopes to start exploring the “radio-sky.” We have received appreciation and new requests, gave answers and supported enthusiasts organizing events and conferences in many cities. We are happy and proud if our work and our passion have brought people closer to this fascinating discipline, contributing to the development of amateur radio astronomy.

We keep going on in this direction with renewed vigor: maintaining the primary objective of the divulgation, of the economy and ease of use, RAL10 has become a complete family of products that meets the demands of the passionate and allows everyone, absolutely everyone, to learn about radio astronomy through the construction, installation and operation of a small telescope.

We always chose the experimental approach way: experience has taught us that the best is to record the radio waves coming from celestial objects with a “homemade” tool.

Of course, we cannot expect the performances of great research telescopes, incomparably larger and more complex. However, the construction and installation of a radio telescope built with RAL10 and with your own hands offers a lot of satisfaction and has great educational value.

Why don't you try and build a radio telescope with us ?

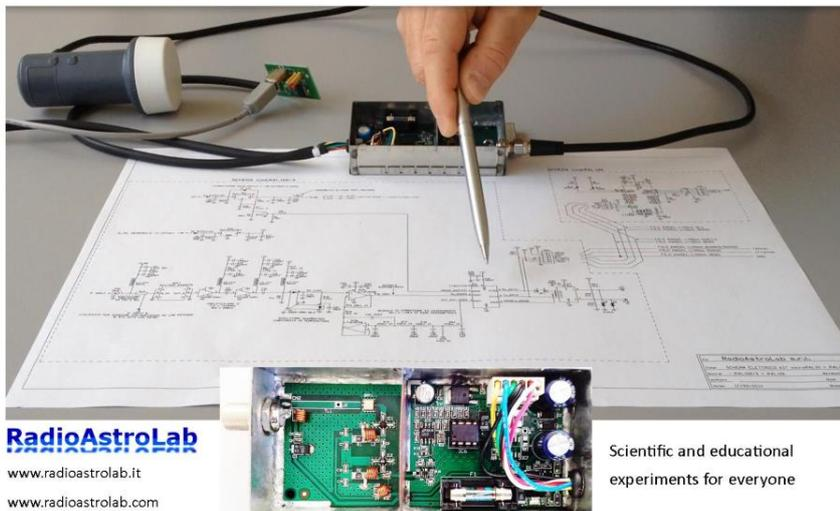

If you try, we can assure you that:

- you will learn the basics of radio astronomy and how radio telescopes work;
- you will learn to “watch” the sky with different eyes (and mind) ...
- you will be able to build and use an amateur radio telescope;
- you will plan exciting radio observations, in parallel with the optical ones;
- you will become friends and supporters of RadioAstroLab!
-

WE HAVE LOT OF NEW PRODUCTS IN PROGRESS... KEEP FOLLOWING US!

2. Some history

The history of radio astronomy began by chance in December 1931: Karl Jansky, an american engineer busy in studying the origin of atmospheric disturbances that made long-distance radio communication difficult, using an antenna (known as "carousel" because of its characteristic shape) and a specially designed radio receiver, discovered the radiation at 20.5 MHz from the center of our galaxy as a "byproduct" of his early work.

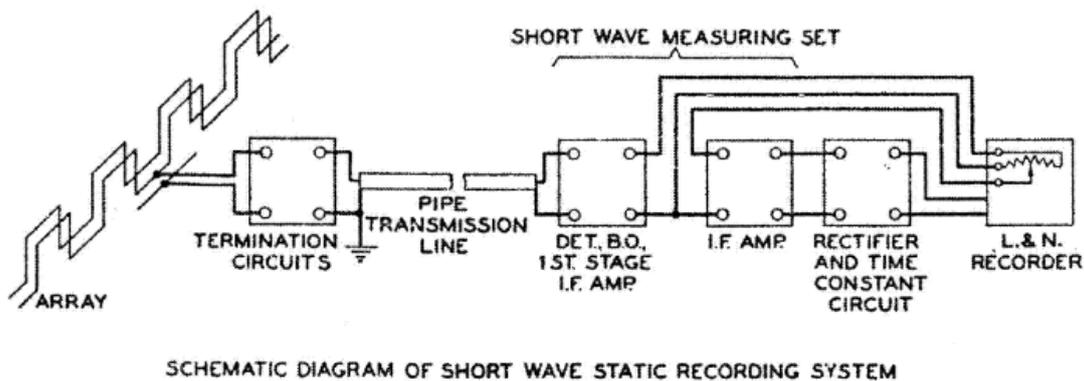

Block scheme of Jansky's receiver ("Directional Studies of Atmospherics at High Frequencies" - K. Jansky, 1932).

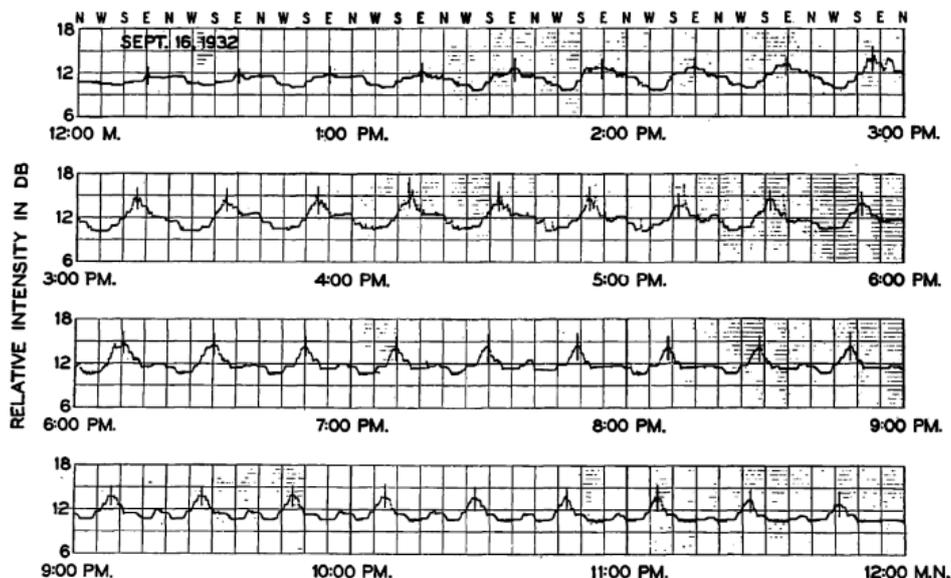

SAMPLE RECORD OF WAVES OF INTERSTELLAR ORIGIN.

The first historical radio astronomic record ("Electrical Phenomena that apparently are of Interstellar Origin" - K. Jansky, 1932).

The images (taken from the original articles of 1932) show the structure of Jansky's instrument and his recordings, where you can see the periodic repetition of the emission peaks from Sagittarius' celestial region, in the center of our galaxy. This was the first (natural...) extraterrestrial radio signal discovered.

The prototype of the modern telescope, seen as a tool built "ad hoc" to observe the sky, was conceived a few years later by Grote Reber. He compiled a map of our galaxy at 160 MHz: by graphing lines with identical received signal strength in function of the antenna orientation, he thus achieved the first "radio-image" of the sky.

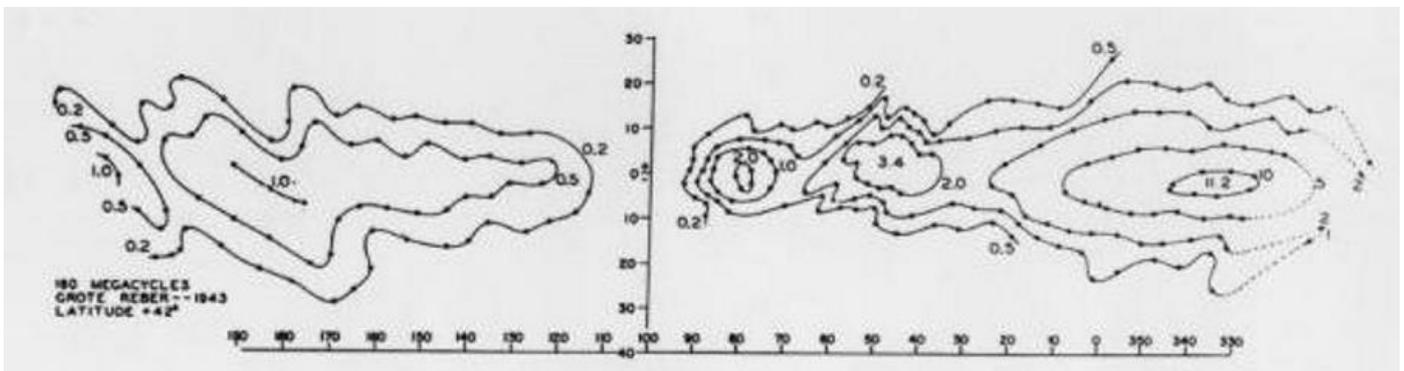

The first radio-map of the galaxy compiled by Reber.

3. What does a radio telescope measure?

In honor of Karl Jansky the unit of measurement of the flux density of radio sources has been defined:

$$1 \text{ Jy} = 10^{-26} \text{ W}/(\text{m}^2 \cdot \text{Hz})$$

This report helps us to understand what does a radio telescope measure: it is a radiant power coming from the sky, precisely the power that affects the uptake of the antenna surface (m^2), included in the receiver bandwidth (Hz).

An alternative way, very convenient to express the signal power "collected" from the antenna, is the so-called brightness temperature: in fact a radio telescope measures the (equivalent) temperature of the scenario "seen" by the antenna. The term "equivalent" will be made clear later. It is possible to demonstrate that, in radio astronomy, the brightness temperature of a radio source is directly proportional to its radiated power.

If we orient the antenna of the instrument in a given region of the sky, in particular to a radio source that "stands out" over the ground, we measure an increase in signal intensity (namely, a power) proportional to the brightness temperature of that object, which will coincide with its physical

temperature only if this is a black body, ie a (ideal) material which perfectly absorbs all radiation incident on it, without reflecting it. In nature there are no black bodies, but there are objects that approximate very well their behavior, at least within a specified frequency band.

If, as noted by Reber, we consider the telescope like a thermometer, we will have that the temperature measured by the antenna, that is the brightness temperature, will be proportional (not identical) to the physical temperature of the region through a coefficient called emissivity of that region. This is the meaning of the term "equivalent" used above. Emissivity is a measure of that material's ability to radiate energy and is a complex function of the chemical-physical properties of the radio source and the frequency characteristics. A black body emissivity is equal to 1, thus having a brightness temperature coincident with its physical temperature, while a material body (gray body) has an emissivity between 0 and 1, then a brightness temperature lower than its physical temperature.

As mentioned, the technology of a radio telescope is not substantially different from that of a home radio-receiving apparatus (such as, for example, a television, a car radio or a mobile phone): obviously, some features are specialized and performance are optimized to measure the very weak signals from space.

The crucial question is that in radio astronomy you need to highlight the noise from radio sources (useful signal) with respect to the noise generated by the electronics and the environment (unwanted signal): these "hiss" cross, identical to those we hear when in an FM no station is tuned, have the same nature and are, in principle, indistinguishable.

In-depth documents will illustrate the techniques used to solve this problem.

4. The screen of the Earth's atmosphere

The official classification of the frequency bands of the radio spectrum is shown in the following table.

The Earth's atmosphere restricts the use of the frequencies usable for radio astronomical observations from the ground, since it behaves as a true barrier to the electromagnetic radiation coming from space. In fact, the direct measurement of the cosmic radiation is limited to two "windows" of the electromagnetic spectrum, one comprised between about 0.3 and 0.8 micrometers (visible window, with amplitude of about one octave) and one between about 1 centimeter and 1 meter wavelength (radio window, with amplitude greater than 10 octaves).

Designazione ITU

banda	frequenze	lunghezza d'onda
ELF	3 – 30 Hz	100 000 km – 10 000 km
SLF	30 – 300 Hz	10 000 km – 1000 km
ULF	300 – 3000 Hz	1000 km – 100 km
VLF	3 – 30 kHz	100 km – 10 km
LF	30 – 300 kHz	10 km – 1 km
MF	300 – 3000 kHz	1000 m – 100 m
HF	3 – 30 MHz	100 m – 10 m
VHF	30 – 300 MHz	10 m – 1 m
UHF	300 – 3000 MHz	1000 mm – 100 mm
SHF	3 – 30 GHz	100 mm – 10 mm
EHF	30 – 300 GHz	10 mm – 1 mm
THF	300 – 3000 GHz	1 mm – 0.1 mm

Classification in the frequency bands of the radio spectrum.

The "radio" window is bounded below by the shielding effects of the ionosphere (electrically charged particles that act as a reflector for radio waves), and above by molecular absorption phenomena due to water vapor and oxygen.

As can be seen from the images, the range of useful radio frequencies for radio astronomical observations from the ground is between about 20 MHz and 20 GHz.

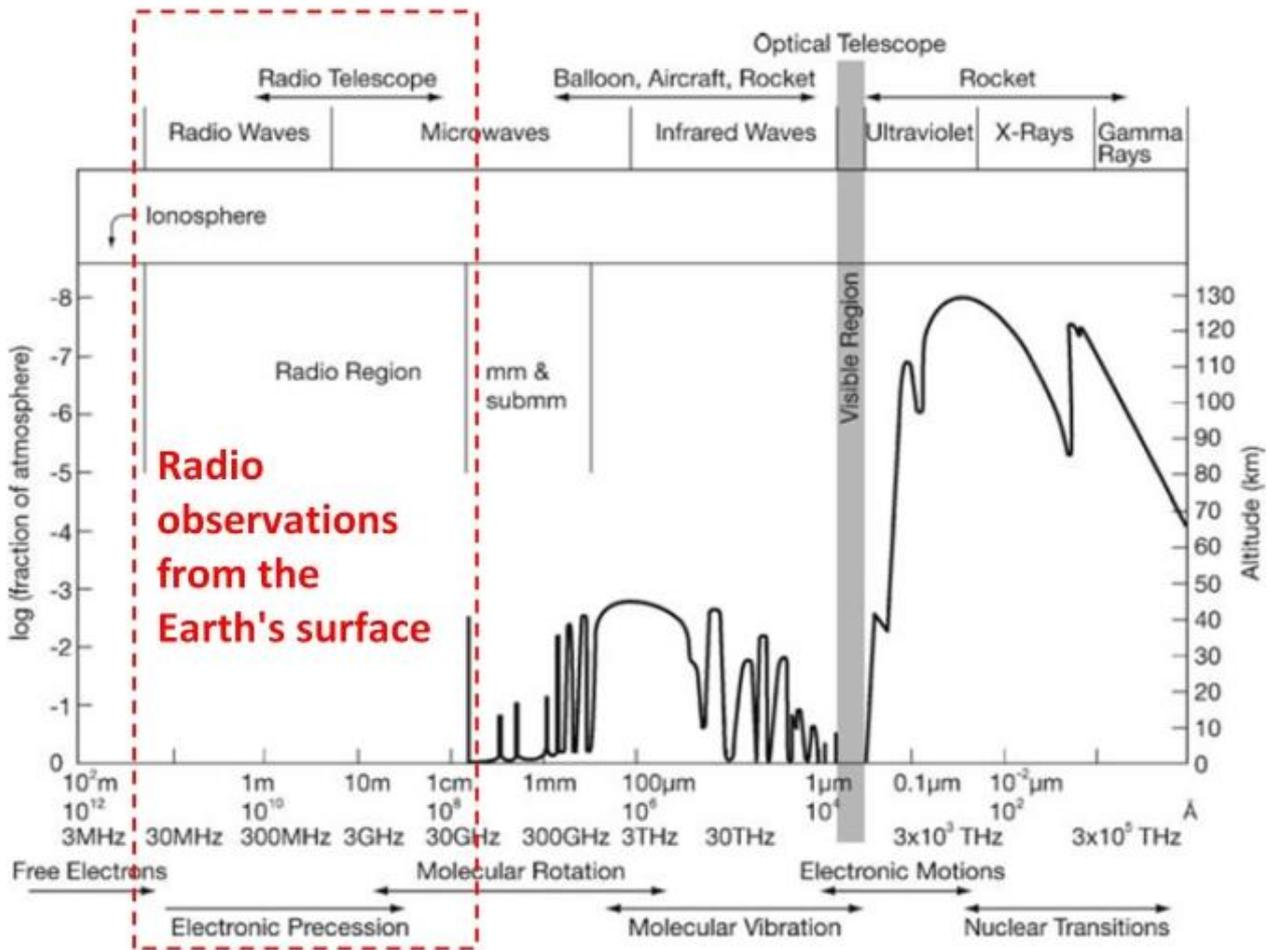

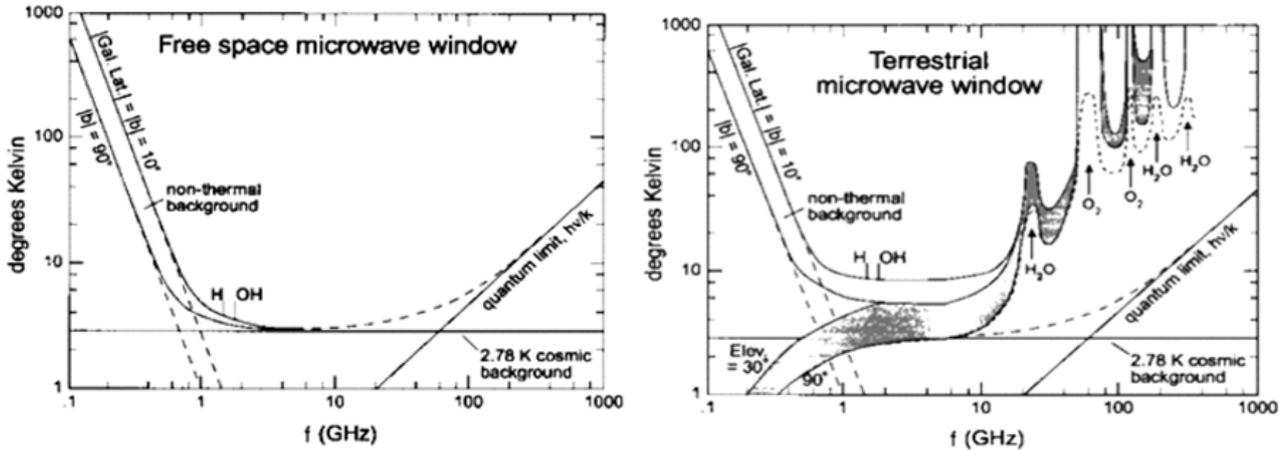

The Earth's atmosphere effects are clearly visible when comparing the graphs that represent the radio "window" of the electromagnetic spectrum from the ground view (left) and from a radio telescope operating in space (right).

5. Does it make sense to talk about amateur radio astronomy?

Admiring the complex and sophisticated technology and the structural impressiveness of professional radio telescopes, not to mention the cost, of course "astronomical", it is legitimate to ask whether it makes sense to talk about amateur radio astronomy and, if so, what are its real possibilities of experimentation.

This discipline is not well known at amateur level: we believe that, from our part, it is important to present and describe concrete projects, economic and easy to implement, with "safe" and repeatable performance. We have to make anyone understand, very honestly, the limits reachable by amateur activities, emphasizing, however, the many exciting possibilities of the open-to-all experimentation. In this light, it becomes for us a mission to support anyone who wishes to begin by following our suggestions.

On your part, a bit of willpower is needed to invest time and patience for a gradual approach to a discipline that seems less immediate and "spectacular" than other observational techniques of the sky as, for example, optical astronomy.

The human being is not sensitive to radio waves: in this field, the "visualization" of the cosmic stage and the "extraction" of the information that results is not immediate. You need instruments (radio

telescopes) that can detect radio signals and display them. These difficulties help to make this discipline much less accessible and "darker" than optical astronomy.

Then there is the problem of instrumentation.

Do you have to be electronic experts to realize everything in the house?

Not necessarily. Who has practical knowledge is, of course, advantaged, but on the web you can find excellent projects on construction of small radio telescopes. On the other hand, we propose modules, kits and comprehensive tools so that anyone can become an amateur radio astronomer.

6. How, what and where to look

The radio astronomy observation "par excellence" (the easiest one) consists in determining how does the intensity of the signal received during the "transition" of a radio source (such as the Sun or the Moon) vary in the "field of view" of the antenna (the so-called *registration to transit*). You orient the telescope at the sky area where the passage of the radio source is foreseen, in its apparent motion, and wait for the formation of the classic "bell" track in the capture software.



RAL10: Moon @ 11.2 GHz

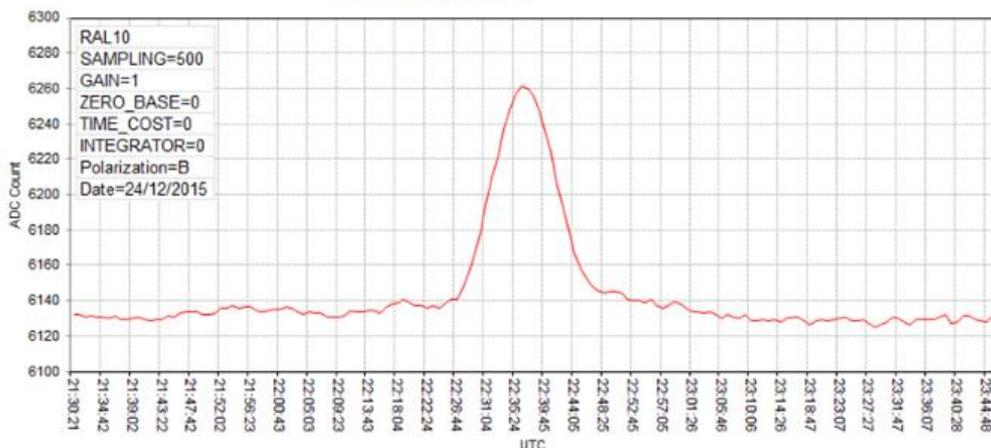

The lunar transit observation with an amateur telescope based on our RAL10 receiver.

The next step, a bit more complex and laborious, contemplates the recording of signal intensity received from different directions of the sky. Slowly and methodically collecting a series of measures, you can fill in a "radio-map" of the observed sky region. Obviously "tracking" observations of the radio sources are possible, such as, for example, when you want to monitor solar activity. This requires motorized and automated equipment for the management of the orientation of the antenna system.

Generally, these are the first questions that every amateur radio astronomer asks himself:

- In which frequency band is it better to work?
- What are radio sources that can be observed with a small telescope?
- Are there special requirements in the choice of the instrument installation site?

You cannot answer any question independently from the others.

The mechanisms that explain the emissions of radio sources are complex, linked to their chemical-physical characteristics. As a first approach will be enough to catalog the most intense radio objects in the sky and discover how does their emission vary at different frequencies (radio source *spectrum*). At amateur level, taking into account the limitations in sensitivity of the instruments due mainly to poor effective area of the antenna, a reasonable first choice seems to favor the frequencies where the radio sources are more intense and numerous. As we see from the following chart, besides the Sun and Moon that behave more or less as black bodies in the radio band (at least for what concerns the emission of the quiet Sun), other radio sources radiate with greater intensity for frequencies below 1 GHz, with an increasing mechanism (called *non-thermal*) with decreasing frequency.

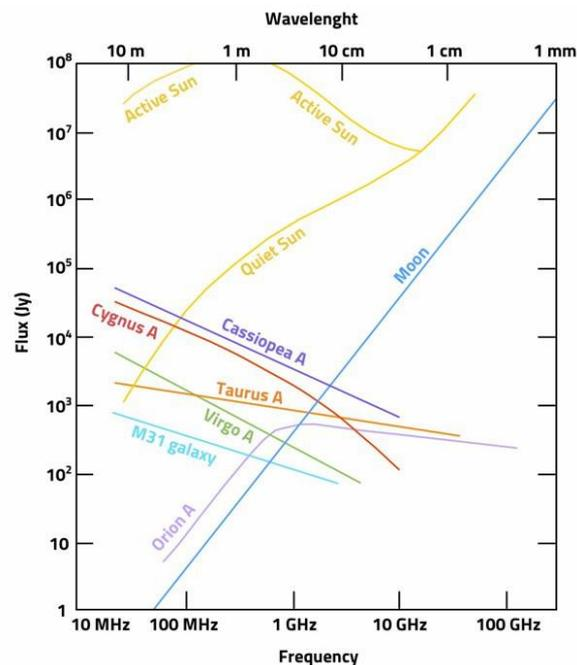

The graph shows how the intensity of emission varies in the radio spectrum band from 10 MHz to 100 GHz.

However, we need to consider the radio "crowding" in the area where we will install the telescope, due to the presence of various interferences. The artificial noise, very intense in urban and industrialized areas, are the real "plague" in radio astronomy observation: the radio spectrum is practically saturated with signals and spurious emissions of various kinds.

The most common natural sources of interference are the lightnings, atmospheric electrical discharges, radio emissions produced by charged particles in the upper atmosphere (ionospheric disturbances), emissions from atmospheric gases and hydrometeors.

Artificial interferences are caused by disturbances produced by the distribution, use and power transformation of electricity, by radar transmissions for the control of the military and civil air traffic, by terrestrial transmitting stations used for radio and television broadcasting services, by the transmitters and transponders on artificial satellites (including the *Global Positioning Satellites GPS systems*), and by mobile phone network and military stations.

As seen from the graph below, the intensity of the artificial and natural disturbances decreases with increasing frequency: it is conceivable the installation of a radio telescope at 10-12 GHz in the "back yard", in urban areas, while it is very difficult the receiving at the lowest frequencies. In the latter case, we must opt for a rural area, electromagnetically more "quiet".

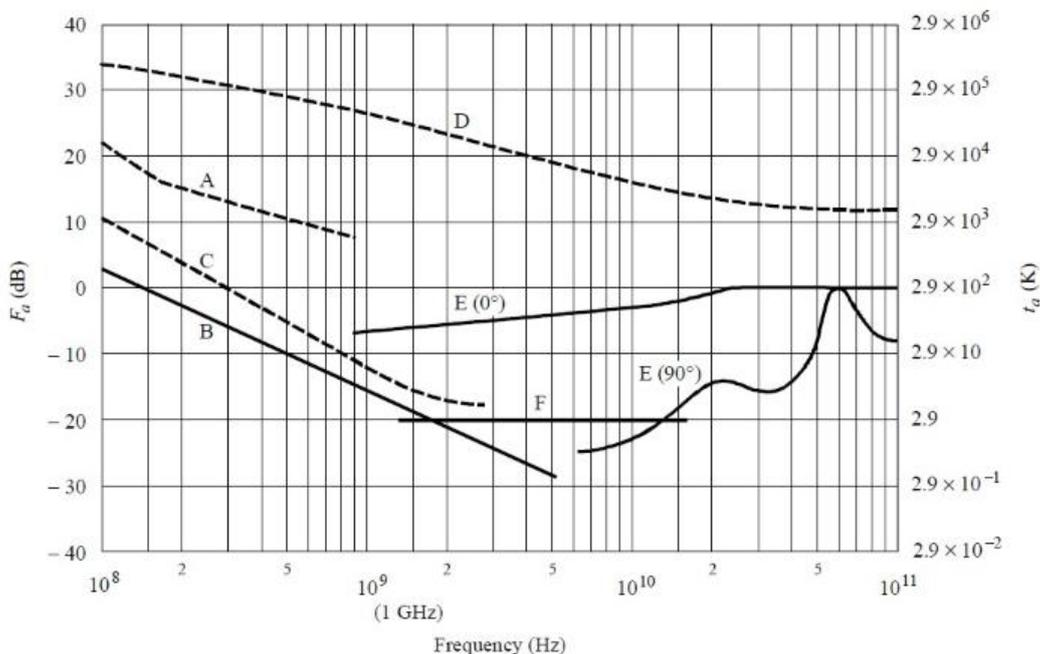

- A: estimated median business area man-made noise
 - B: galactic noise
 - C: galactic noise (toward galactic centre with infinitely narrow beamwidth)
 - D: quiet Sun ($\frac{1}{2}^\circ$ beamwidth directed at Sun)
 - E: sky noise due to oxygen and water vapour (very narrow beam antenna); upper curve, 0° elevation angle; lower curve, 90° elevation angle
 - F: black body (cosmic background), 2.7 K
- minimum noise level expected

Performance of natural and artificial noise power in function of the frequency. It shows the levels estimated in the range from 100 MHz to 100 GHz (Recommendation ITU-R P.372-7 "Radio Noise").

Indeed, the choices based on the analysis of the spectrum of radio sources are contrary to those deriving from the analysis of the spectrum of disturbances: we have a "pro" and "cons" tie. Decisive will be the technological and economic considerations.

An amateur radio telescope "for all" should be easily achievable, economic and of immediate operation: the "heart" of the instrument should be a module designed "ad hoc" for radio astronomy that integrates the essential parts of a basic radio astronomy receiver.

Around this core, the researcher completes the telescope using commercial parts and modules, economic and easily available. All this is possible thanks to the spread of satellite TV reception in the band 10-12 GHz, and the availability of antennas, amplifiers, cables and a host of accessories, new and recycled, suitable for building a perfect amateur radio telescope.

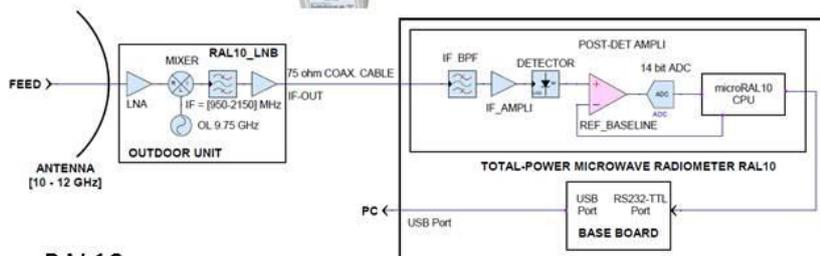

RAL10: the family of receivers for amateur radio astronomy.

We know that the antenna size greatly influences the final cost of a radio telescope. Also the commercial availability of this critical component plays a fundamental role.

If we consider that, with the same antenna gain (is a measure of its ability to capture weak signals in specified directions of space), its dimensions (therefore weight and size) decrease with increasing

frequency, using a common parabolic reflector antenna of 1 meter diameter for TV-SAT 10-12 GHz, we can easily build our radio telescope.

The only drawback is the limited number of measurable radio sources: the Sun and the Moon, with small diameter antennas. However, being their radiation very intense, their study is an excellent "training" to begin to familiarize yourself with the tools and techniques of radio astronomy.

To reveal weaker radio sources (Taurus, Cassiopeia, Cygnus, Virgo) you need larger antennas, while keeping the rest of the system unvaried.

These are the reasons that have guided us in developing the family of microwave receivers RAL10 for amateur radio astronomy.

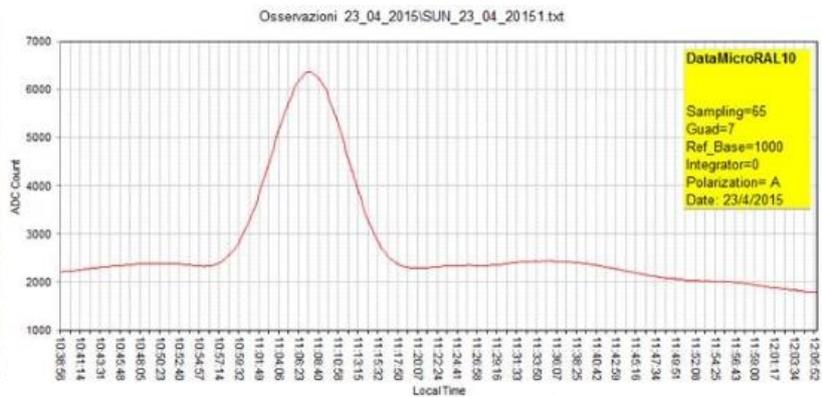

Tests of radio astronomy @ 11.2 GHz : the radio signals from the Sun with RAL10AP.

7. What future expansions are imaginable with RAL10?

The RAL10 receivers are versatile and offer many possibilities of use: their input bandwidth, in fact, includes the intermediate frequencies (IF) 900-2000 MHz, a standard for devices *Low Noise Block Converter (LNB)* used for the satellite TV reception in Ku-band (10-12 GHz) or C-band (3-4.5 GHz). The effective working frequency of the radio telescope will coincide with the input frequency of the selected LNB block. We remind you that the external LNB unit, often comprising the illuminator for parabolic reflector, is the device placed directly on the antenna focal point. A coaxial cable will transport to our radio astronomy receiver the signal already converted to the IF band. It is a frequency converter (downwards) of the received signal.

The *radiometric module microRAL10*, common to all RAL10 products, is the "heart" of our receivers for radio astronomy and implements the most important functions. For those who want to deepen its functioning we suggest the reading of the related in-depth documents. It is a radiometer operated by a microprocessor which amplifies the signal coming from the external LNB module, calculates the power of the received signal, "digitizes" the information and communicates with the station PC through a USB port. Operating parameters are programmable and all the important functions of a radio astronomy receiver are implemented. The device is sensitive, stable and characterized by high degree of measurement resolution.

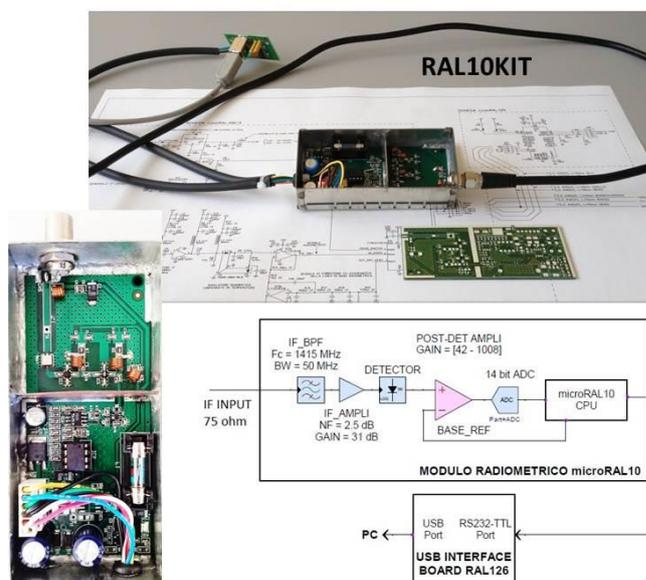

Radiometric module *microRAL10*, the core unit of radio astronomic microwave receivers of RAL family.

If the operating frequency of our radio telescope is not too high, you can remove the external block LNB amplifier-converter implementing a direct conversion amplifier. The signal collected by the antenna will be amplified with low noise and filtered to operate at the set frequency, with the desired passband. In fact, the *microRAL10* input amplifier is broadband: it is not difficult to eliminate the original internal filter and insert an outer group of amplifiers with a band-pass filter "cut" to the desired working frequency. Obviously, with this configuration it is difficult to achieve bandpass filters with very narrow window: you must always check the effective "cleansing" of the chosen spectrum portion.

As an example, the following images show an experimental radio telescope, working at the "magic" frequency of 1420 MHz, based on RAL10AP receiver.

20 dB GAIN HORN ANTENNA

Stage Data	Units			
Stage Name:		1420 MHz LNA	TV-SATLINE AMPLI	RAL10AP
Noise Figure	dB	1	2	
Gain	dB	40	12	

Experimental Radio Telescope used for the reception of Cygnus A to 1420 MHz

1420 MHz – 20 dB
Horn Antenna

1420 MHz-40 dB
LNA (1 dB NF)

Standard TV-SAT 12 dB Line Amplifier (950-2250 MHz)

RAL10AP
Microwave Radiometer

How to use RAL10AP Microwave Radiometer for receiving radio emission of the Milky Way at 1420 MHz.

Example of direct amplification receiver built "around" the radiometer RAL10AP. It is used an antenna horn (20 dB gain), a low noise amplifier (LNA) with band-pass filter centered on the frequency of 1420 MHz (connected immediately after the antenna), 30 meters of coaxial cable that

carries the signal within the station. Before connecting the cable to the receiver RAL10AP a commercial line amplifier for TV-SAT is included.

We propose instruments designed "ad hoc" for the amateur radio astronomer: simple, modular and ready to use, which leave room for constructive imagination of the individual enthusiast and offer many possibilities for expansion.

If you'll have the patience and the pleasure to follow us, you will find extensive documentation about our products that grows and develops over time. The software that controls our tools will always be available, free and updated, while our pages will host many examples of realizations and experiments based on Total-Power RAL10 receivers, made by us or by our friends who want to share the fascinating experience of amateur radio astronomy research.

Room for imagination!

Using our core modules, the wide range of components and accessories from the Satellite TV market and taking advantage of our support, there are no limits to the customization of your instrument.

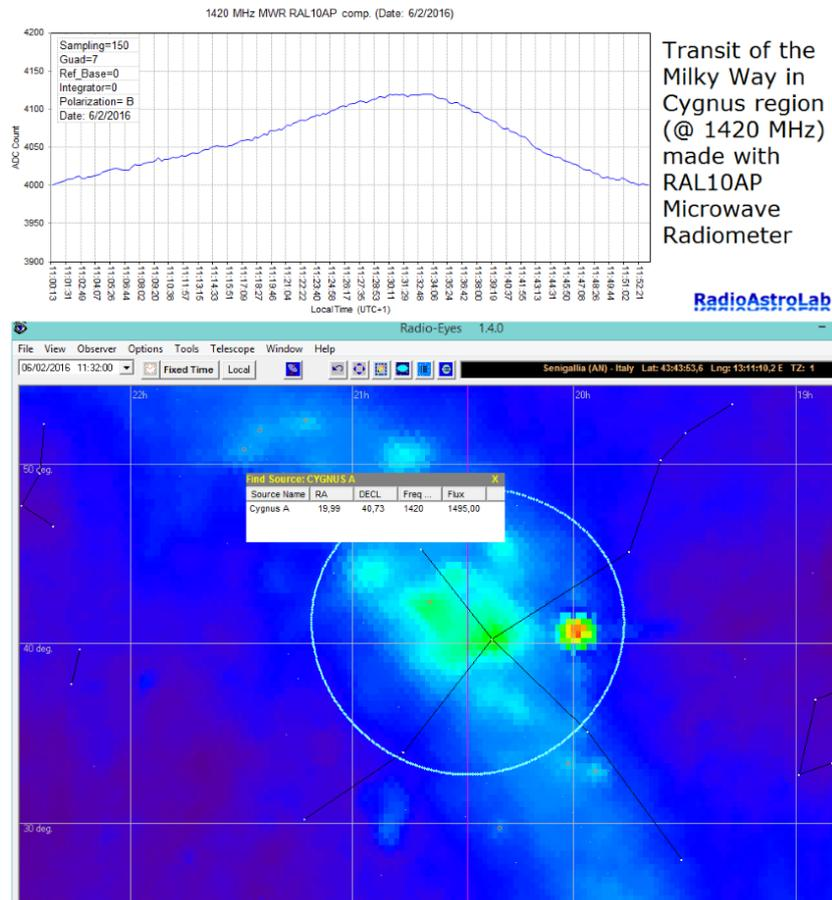

Transit of the Milky Way (region of the Swan) carried out with an experimental radio telescope based on the [RAL10AP](#) receiver. The system reveals the radio emission of the Galaxy at 1415 MHz (with a theoretical bandwidth of 50 MHz). The radiation includes the continuous component and the neutral hydrogen contribution to 1420.406 MHz, which falls into the "receive window" of the radio

telescope. This record does not show the profile of the neutral hydrogen line, but the continuous emission of the Galaxy and of the radio source Cygnus A unresolved because of the wide "field of view" antenna (around 16°).

8. The radio telescope becomes a measuring instrument

Each tool analyzes a physical quantity according to a specified scale of measurement units. This is true also for a radio telescope: in fact, a very important and delicate part of its functioning concerns the calibration. It is necessary to establish a calibration procedure to obtain, at the output of the radio telescope, data consistent with an absolute scale of brightness temperatures (or of flow units). The constructional tolerances and environmental conditions cause changes in the operating parameters of the components of the receiver, moreover each instrument is unique in its response and is difficult to compare measurements from different telescopes or those of the same system carried out at different times. By repeatedly observing a radio source you may experience changes in the intensity of the emission peak. It is important to understand whether these fluctuations are due to real changes in the source stream or to unwanted variations in the response of the instrument: it is therefore necessary to use a universal measuring system. The calibration procedure of a radio telescope is used to establish a relationship between the brightness temperature of the scenario observed [K] and a given amount output from the instrument [ADC count].

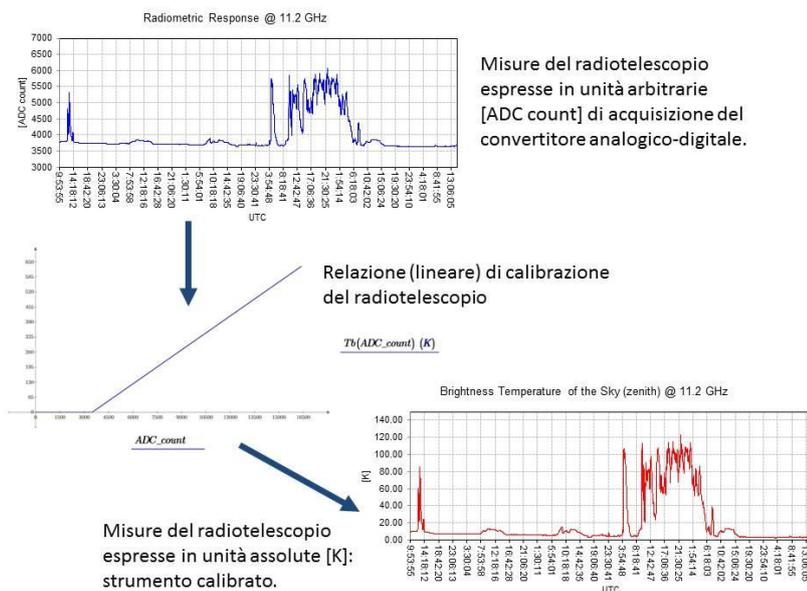

A radio telescope measures the intensity of the radiation coming from the scenario observed in arbitrary units [ADC count]. These units represent the numerical value of the output of the analog-to-digital converter (ADC), internal to the instrument, of the "digitized" analog quantity (revealed radio signal). A calculation transforms the response of the instrument in absolute temperature units [K] using the calibration relation of the radio telescope.

9. Radiometer or radio-spectrometer?

A *radiometer* is a receiver which measures the average power of the radiation picked up by the antenna within its receiving "window", showing how the power of the received signal varies over time. As can be seen from the following figure, the quadratic detection and subsequent integration process does not preserve the spectral characteristics of the signal: it provides a single value that represents its average power within the receiver passband.

If you are using stable broadband receivers (the amplification factor of the system and the detector characteristics should not change during the measurement), you can reach very high sensitivities, especially thanks to the possibility of integrate the detected signal (moving average operation using many signal samples) with long time constants, admitted that the phenomenon to be studied is sufficiently stationary in time.

To study the signal in the frequency domain, highlighting its spectrum "signature" and identifying the various components of different frequency distributed within the bandwidth of the receiver, it is necessary to adopt a different structure.

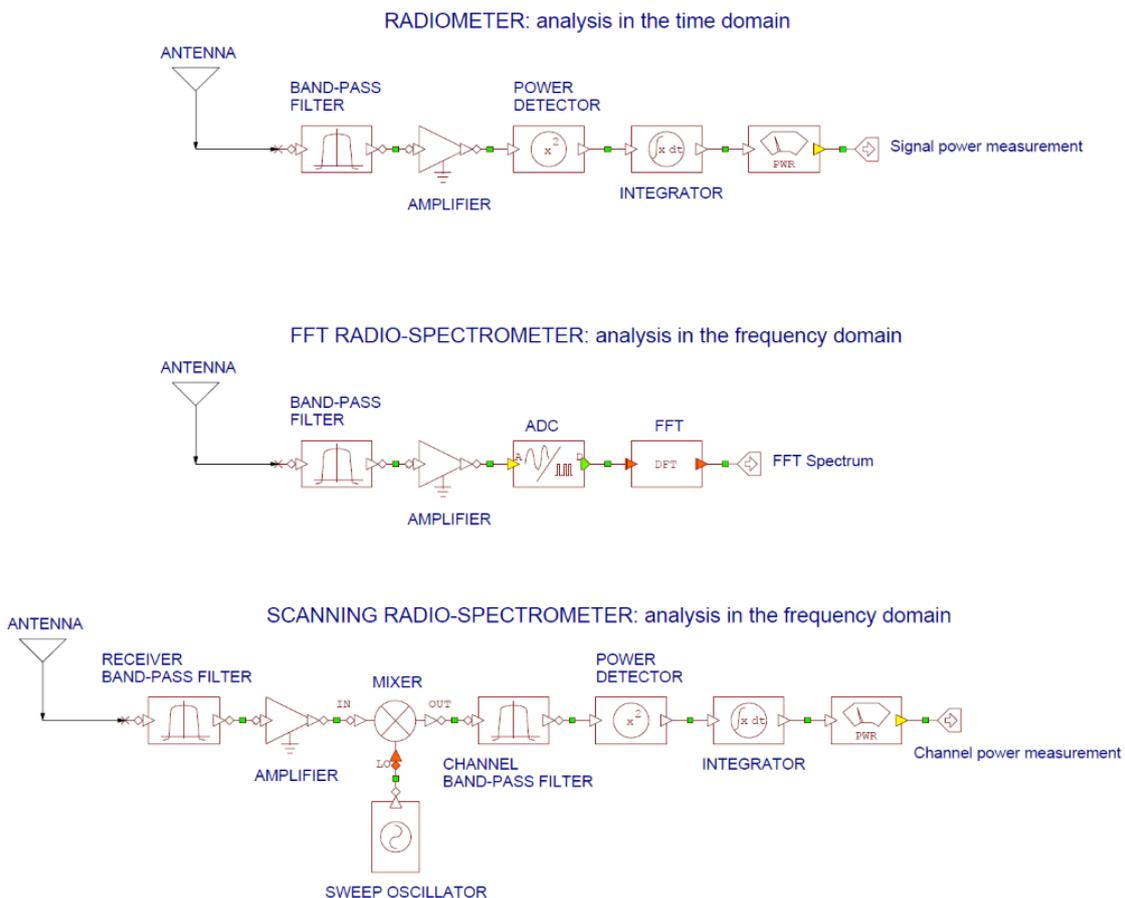

Basic architectures of receivers used in radio astronomy: radiometers and radio-spectrometers.

Neglecting the complex and expensive architecture of the radio-spectrometer with banks of narrow-band filters, outdated and of little interest, the two types that can be useful are *frequency scanning radio-spectrometer* and *FFT radio-spectrometer*.

The first is a frequency conversion receiver (heterodyne principle) where the "receiving window" is periodically scanned by a local variable frequency oscillator which moves, inside of the intermediate frequency channel, a narrow portion of the frequencies received. At each step of the scan it is calculated signal power as in a radiometer. After the scan, we will have a complete representation of the received signal power spectrum.

This representation will be much more accurate (and slower), the narrower will be the bandwidth of the intermediate frequency channel filter with respect to the reception band. Moreover, the greater will be the constant of integration which performs the average of the channel power, the lower the amplitude of noise visible in the track and still slower the scan. These parameters are optimized as a function of the stationarity characteristics in time in the measured signal and of the required sensitivity for the receiving system.

To also obtain the phase information of various spectral components, as happens in laboratory vector analyzers, additional circuits are necessary.

A frequency scanning radio-spectrometer does not scan in real time the entire reception band: during each scanning period is measured only the small portion of frequencies selected from the local oscillator, as wide as the bandwidth of the intermediate frequency channel filter. To capture any rapid spectral changes is necessary to foresee a sufficiently "agile" scan, to the disadvantage of sensitivity related to the integration of the detected signal.

Many amateur radio telescopes that analyze the profile of the hydrogen line at 1420 MHz, for example, operate according to this principle, using radio amateur receivers such as spectrum analyzers in frequency scanning.

No particularly action is required in data processing: the output already contains the intensity information of each spectral component. You just have to "digitize" the detected signal at each scanning step with an analog-digital converter (ADC) not particularly fast, managing the measurement process via dedicated software on PC.

An efficient radio-spectrometer uses numerical techniques to calculate instantly spectrum of the signal present within the receiver passband. This is possible thanks to the evolution of modern electronic devices and to the computing power of Personal Computers (PC).

As can be seen from the block diagram, the structure of the *FFT radio-spectrometer* is conceptually very simple, although technologically advanced: the whole receiver passband (directly or after a translation in frequency) is acquired via a fast analog-to-digital converter and the relative samples in the time domain are converted into spectral samples (in the frequency domain) by a processor (it is almost always a PC managed by dedicated software) that uses the mathematical algorithm DFT (*Discrete Fourier Transform*), a numerical version of the Fourier Fast Transform (FFT).

It is thus obtained the instantaneous spectrum of the signals within the bandwidth of the instrument. It is obvious that, in case of the presence of a conversion stage (heterodyne) of the reception frequency,

the local oscillator (fixed) should be characterized by high spectral purity and stability not to degrade the performance of the instrument.

The obvious advantage of this system is the possibility to analyze, in real time (latency calculation in part), high bandwidths in the frequency domain. Of course, the actual performances of the system are functions of the technological capability of the devices used (fast ADC), and the computing power of the processor that performs the DFT.

The instrument is widely used in the monitoring of disturbances in the frequency bands of radio astronomy interest, in the monitoring of space debris and meteorological events (tracking techniques with bi-static radar), in the study of molecular lines, in the SETI researches and in many other applications.

In the following chapters we will describe a radio-spectrometer made by us (*RALSpectrum* prototype) for the study of neutral hydrogen spectral line at 21 centimeters and a similar receiver built for Meteor Scatter experiments in VHF band.

Thanks to the spread of SDR architectures (*Software Defined Radio*), to the increase in PC computing power and the ability to find excellent free programs for spectral analysis on the web, you can now build economical radio-spectrometers usable in amateur radio astronomy applications.

Again, surfing the web you will find many examples and imaginative applications, ranging from the receipt of sporadic Jupiter's radiation and solar radio-storms in the frequency band from 20 MHz to over 40 MHz, to radio-echoes reception of meteors in the VHF band, to the study of the neutral hydrogen line at 1420 MHz and the SETI researches.

This is an industry in constant and rapid evolution: also in our pages we will present projects, experiments and products dedicated to the study in the domain of radio astronomical signals frequency.



A well-known example (and documented on the web) of "minimal" and economical radio-spectrometer usable for amateur radio astronomy experiments: it is a USB stick originally produced as a USB 2.0 DIGITAL TV TUNER RECEIVER, modified by us to improve the heat dissipation and immunity to external disturbances.

By combining with this device antennas, low noise RF amplifiers (LNA) and, if appropriate, bandwidth filters to improve the reception dynamic and optimize the immunity to external interference, you may tune to frequencies from about 20 MHz to about 1500 MHz with an instantaneous bandwidth up to 10 MHz. On the web you can find free software and drivers available for download to turn these devices in "radio-scanner".

10. Radio observation of meteoric events

A very interesting activity is the radio observation of astronomical phenomena that influence the Earth's ionosphere.

In this case, you should not talk about radio astronomy, if by that term we indicate the observation of cosmic sources, outside the Earth's atmosphere. However, it is customary, at an amateur level, including in the field of radio astronomy also the analysis of astronomical phenomena that produce measurable effects in the radio spectrum, such as ionospheric perturbations induced by radio-meteor events or the activity of the Sun.

It is interesting to illustrate the *Meteor Scatter* technique that uses a bi-static radar configuration to record the radio reflections produced by the ionized contrails that are formed (at about 100 km altitude) when very fast objects from outer space get consumed in entering the atmosphere Earth.

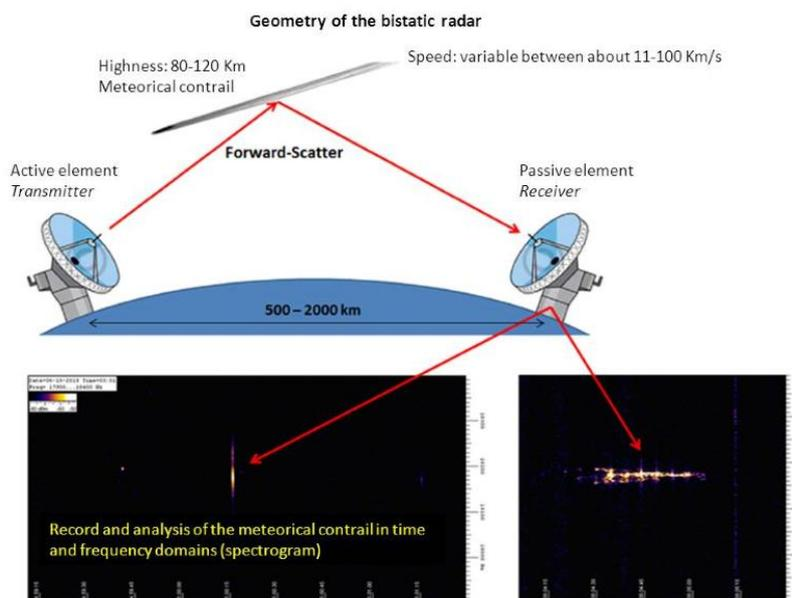

The image of the bistatic radar geometry was taken from the document: "Sistema a uso didattico per la ricezione di echi radar meteorici" - G. Pupil, C. Bortolotti, M. Roma - IRA 483/14.

The spectrograms shown below are records of meteor echoes made by our experimental VHF station. The receiver is tuned (typically in the VHF band, from about 30 MHz to 200 MHz) on the frequency of a powerful radio transmitter, far enough not to be normally received in direct wave because of the Earth's curvature. The transmitter constantly "enlightens" a large portion of the sky. Only when the meteoric track reflects or diffuses obliquely (*forward scattering*) the incident radio waves generated by the transmitter, they can reach the receiver and produce an echo radar.

The phenomenon (with a typical duration from fractions of a second to a few seconds) is studied by analyzing the evolution in time of the spectrum associated with radio reflection of ionized meteor trail (spectrogram), using free software available on the web. Measuring the received signal strength and its Doppler frequency shift, you can obtain important information on the source movement.

The system is conceptually simple and economical, to the reach of all: it is sufficient to have a good VHF receiver operating on the same frequency of the transmitter, an antenna (typically a yagi) and a PC equipped with appropriate software.

You can choose among several transmitters as sky "illuminators": commercial FM broadcast stations operating in the range 88-108 MHz (it is not always easy to do, given the in-band overcrowding), analog TV broadcasters (unfortunately there are few left, all in Eastern Europe), or dedicated transmitters as that of the French GRAVES radar, operating at 143.050 MHz and used to control the space debris in orbit around the Earth.

For our testing we opted for this choice.

It is very important that the transmitter guarantees a continuous service and it is at a distance, from the receiving station, comprised between 500 and 2000 km. It is desirable that the transmitted signal power is stable, at non-modulated continuous wave (CW) and that the transmitter antenna beam "illuminates" always the same area of the sky, without spatial variations.

Much documentation is available on the web that illustrates the principles and techniques of this interesting research, especially accessible for enthusiast. The following images illustrate our experiments. Further documentation can be found in the in-depth section.

RAL_MET Station - Senigallia (AN), Italy

The bi-static radar receiver section that uses the 143.050 MHz transmitter GRAVES (France) for the study of meteors with Meteor Scatter technique.

RadioAstroLab

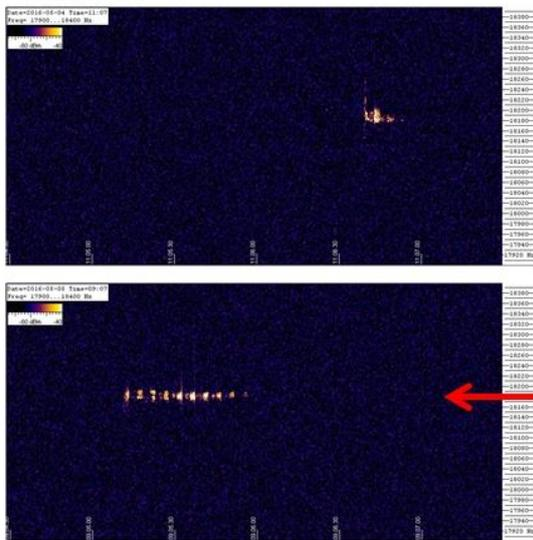

Recording and periodic analysis of the spectrogram (Spectrum Lab software specially configured).



Antenna LNA with 143.050 MHz band-pass filter.

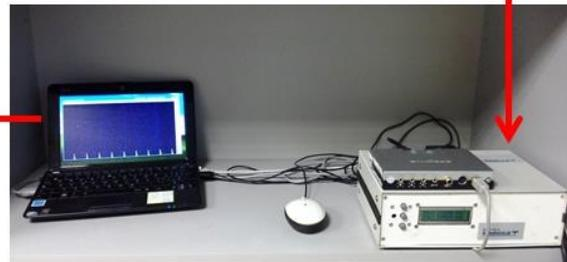

RAL_MET receiving station: working continuously 24 hours a day.

RALmet: RICEVITORE 140-146 MHz per METEOR SCATTER

by Flavio Falcinelli

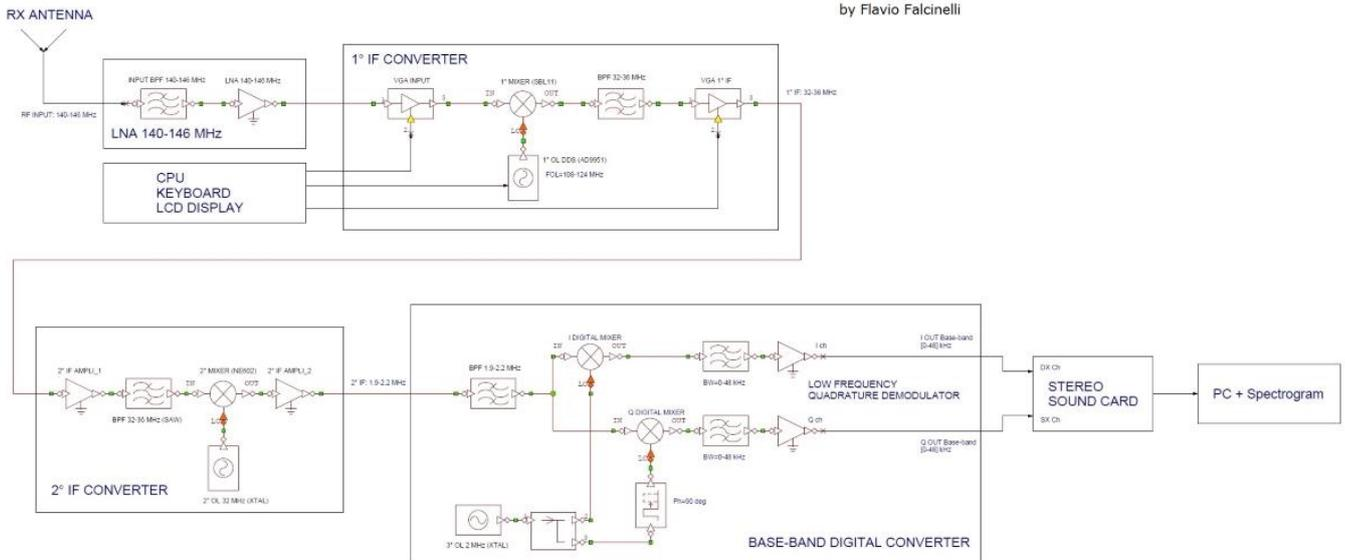

Stazione RADAR Graves – France 143.050MHz
ELEMENTO ATTIVO del RADAR BI-STATICO



Stazione fissa Senigallia (AN) – Italy
ELEMENTO PASSIVO del RADAR BI-STATICO

Our experimental Meteor Scatter station operating at 143.050 MHz, optimized for receiving meteoric echoes produced by the French GRAVES radar. The receiver and antenna are built "ad hoc." The station operates continuously recording, at regular time intervals, the received spectrograms. Every day the data are downloaded from the station PC and analyzed. We are performing counts of events, spectral analysis and statistical analysis.

Technical characteristics of the receiving station:

ANTENNA: dipole with balun;

RECEIVER: at triple frequency conversion, with DDS as first local oscillator;

Output audio baseband [0-48 kHz], quadrature signals I & Q;

ACQUISITION: external 24-bit audio card, 96 kHz sample rate;

SOFTWARE: Spectrum Lab (free by DL4YHF).

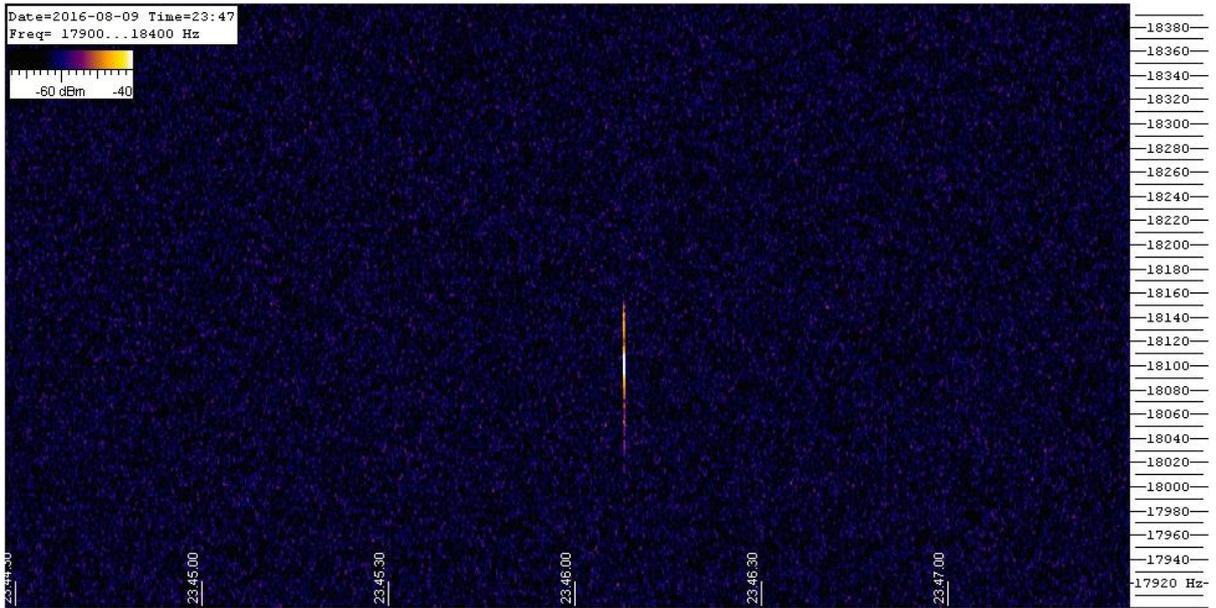

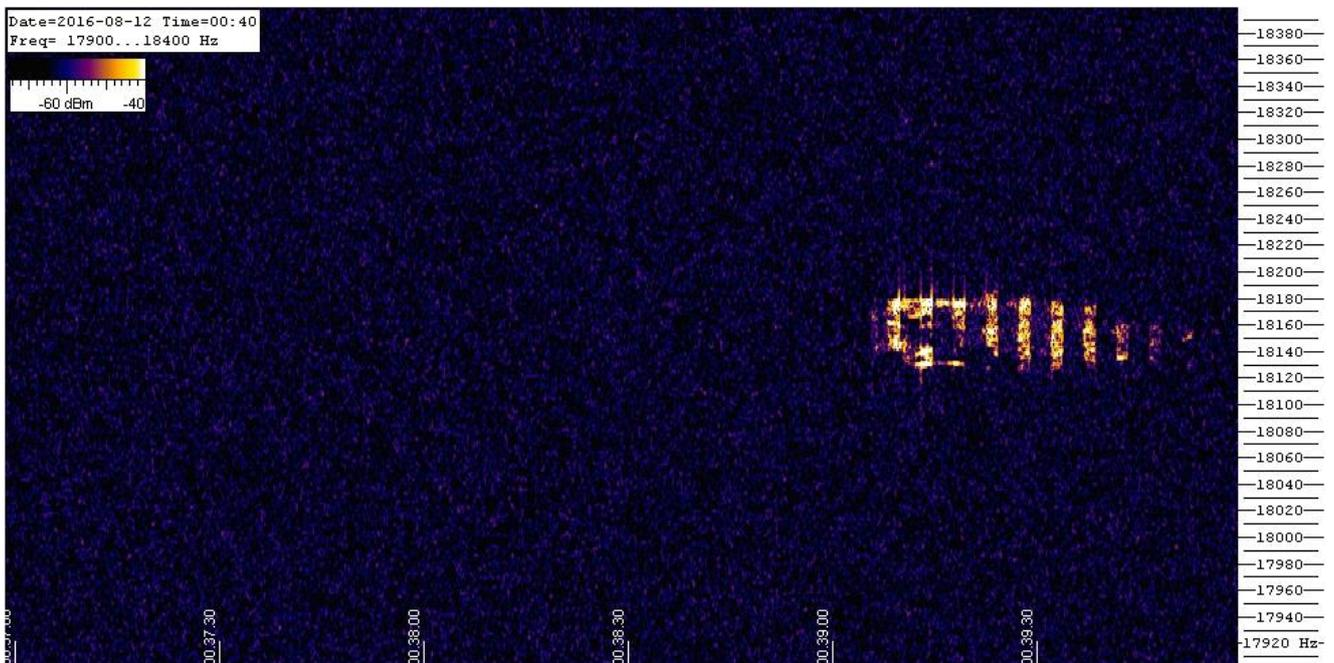

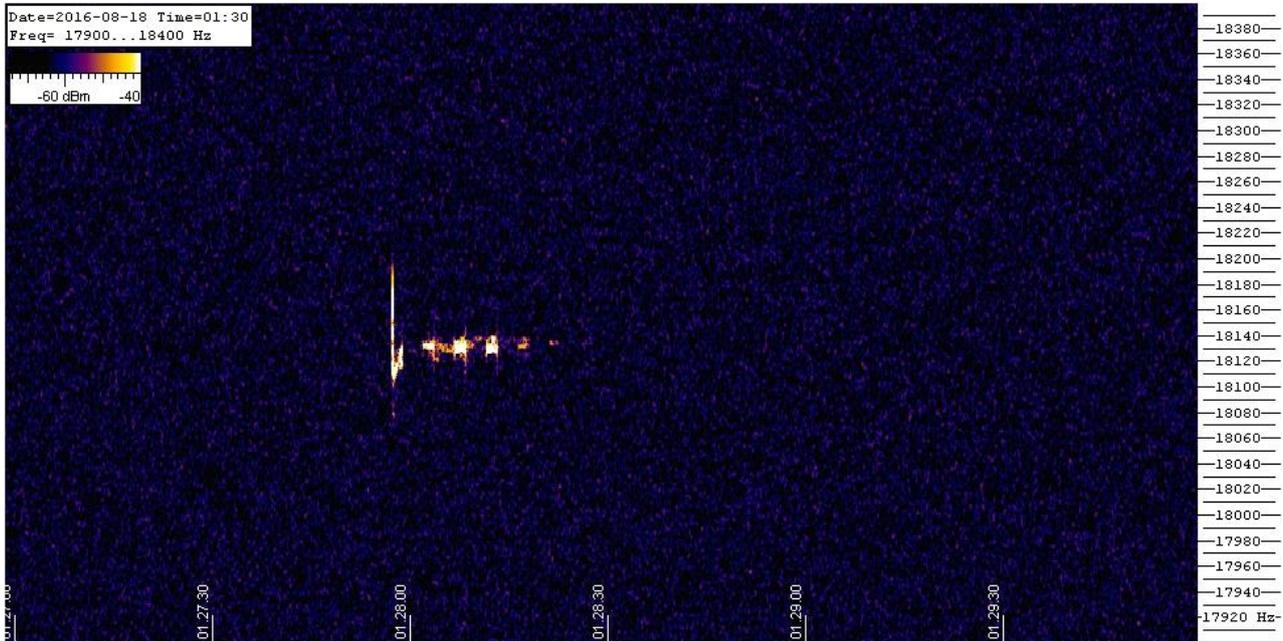

Example of spectrograms documenting considerable meteoric events captured by our experimental station.

Radio Meteors @ 143.050 MHz GRAVES radar - By RadioAstroLab (2015 - 2016)

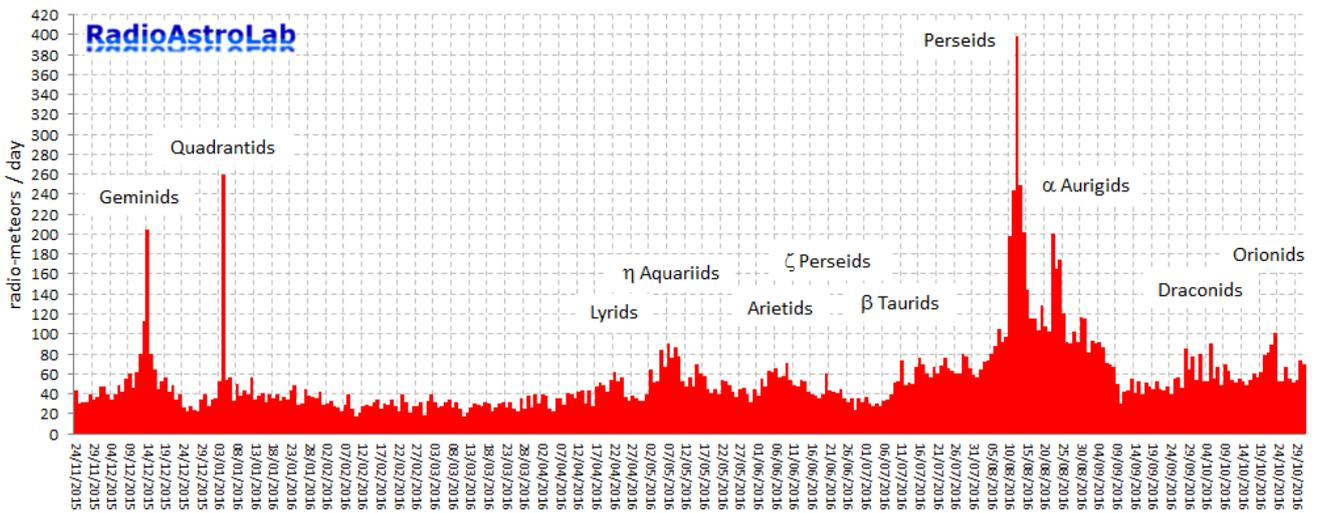

The graph shows the updated results of the counting of “radio meteoric” events recorded from our station.

The research highlights the main meteor showers: during the expected days of peak, the number of recorded events is much higher than the background value due to sporadic flow.

Here are some technical considerations on the research, which is still in progress.

As you can see "wandering" through the web, there are many excellent and varied experiments in this area, most led by radio amateurs. Hereby I will highlight the peculiar aspects of this project, with reference to the experience gained during the long and patient work of analysis of the results.

A lot of attention has been paid to the construction of a receiver "ad hoc" (very stable, without any automation in the frequency and gain control), centered on the 143.050 MHz frequency of the French radar transmitter Graves (as the crow flies, about 725 km from my station). The antenna is a simple specially built dipole. To attenuate the low antenna gain, a well-filtered pre-amplifier was included.

The large receiving lobe of the dipole is a great advantage: if suitably oriented with respect to the transmitter and positioned at a proper height from the ground, it allows the reception of meteoric echoes without too many limitations from the orientation point of view, safely when more violent weather events occur. When such antennas are coupled with a sensitive receiver, optimized in its pass band (only the one needed...), combined with a spectrogram acquisition software suitably configured as *Spectrum Lab* (excellent job by Wolfgang Büscher - DL4YHF), the results are great, at least for the goals of our project.

Even accepting a reduced antenna sensitivity, we could see how a sufficient distance from the transmitter (Graves, in our case), such as to prevent direct reception of its carrier (along with all the spurious radio echoes, including those caused by air traffic) and a perfect antenna-receiver pair are crucial to discriminate, without errors, the radio reflections caused by the meteors.

By choice, we avoided any automatic system for the counting of events: after many tests, we configured *Spectrum Lab* for a complex acquisition (I & Q) of the baseband channels of the receiver (acquired from an audio card external to the PC, connected via USB) with rejection of the frequency image, enhancing the resolution in the spectrogram frequency and setting a periodic and automatic data logging (a spectrogram every 3 minutes).

The use of *TeamViewer* software enables the remote control of the acquisition PC, with the ability to download every day the spectrograms recorded.

The following data analysis is visual: you need to patiently check the individual records to detect spectral "signatures" of radio-meteoric events. This approach, certainly more laborious than the automatic counting, is very accurate and reliable (it minimizes, above all, the counting of "false" events), even if it requires an initial period of "running-in" to gain experience.

Much more could be said.... We will talk about it in the next articles.

The tests go on.

N. Meteors/hour (04.01.2016) @ 143.050 MHz GRAVES Radar

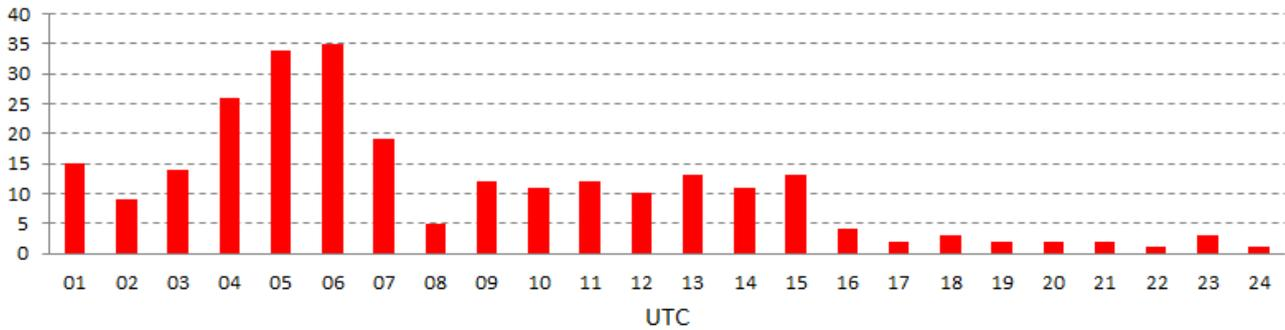

The radio-meteors recorded every hour by our station were counted, in a day. You can see how the ultimate meteor stream happens to the early hours of the morning, while the minimum to the afternoon and evening hours: although the daily number of radio-meteor events is characterized by large diurnal variability, the average ratio of the maximum and the minimum peak is of the order of 5. The number of events observed during the day will be greatest during the early morning hours, when the observer "impacts" head-on with the meteor stream due to the motion of the Earth movement in space.

N. Fireballs per month @ 143.050 MHz GRAVES Radar

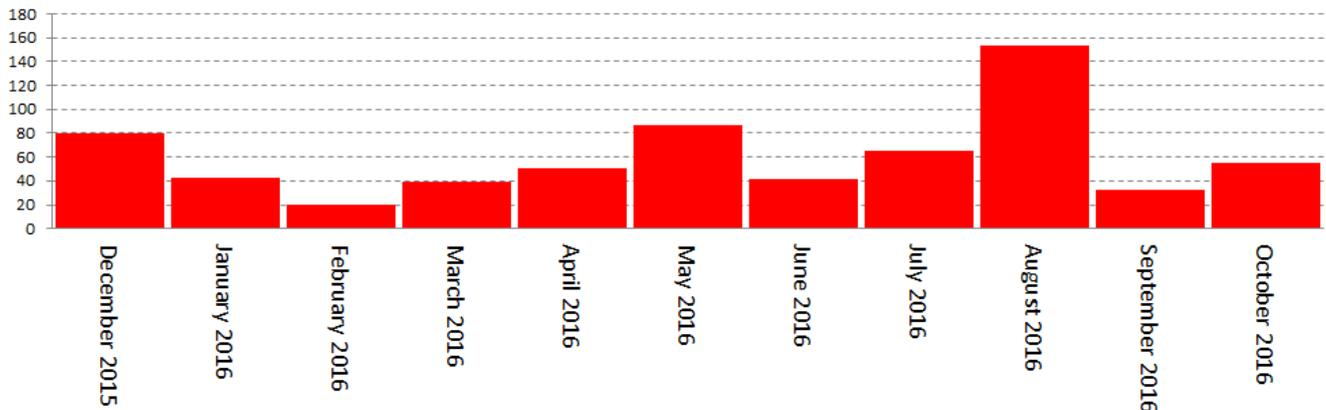

In this graph we were counted the most significant meteoric echoes (generically called "radio-fireballs") recorded in a month. The classification criterion is empirical, based on the visual analysis of spectrograms recorded every day by our fixed station: all events were counted, while only the pictures that show the spectrograms recording the more intense and longer lasting radio reflections were saved.

So interesting events deserve, undoubtedly, far more accurate and complete analysis of those shown on this page, which are to be regarded as a stimulus and a starting point to experience in this fascinating activity.

We want to highlight that it is actually easy and economical to install a permanent station dedicated to the study of radio-meteor events through the Meteor Scatter technique in the VHF band,

activities that can be coordinated with other observers, both in the visual, both in the radio, in order to verify possible correlations of events, especially during major meteor showers of the year.

In conclusion, we report some animations which show, in sequence, the most important monthly radio-meteoritic events, for intensity, shape and duration. These records, which we will update regularly, are very important because they represent the "spectral signatures" of the observed phenomena and are the basis for their classification and interpretation.

RadioAstroLab

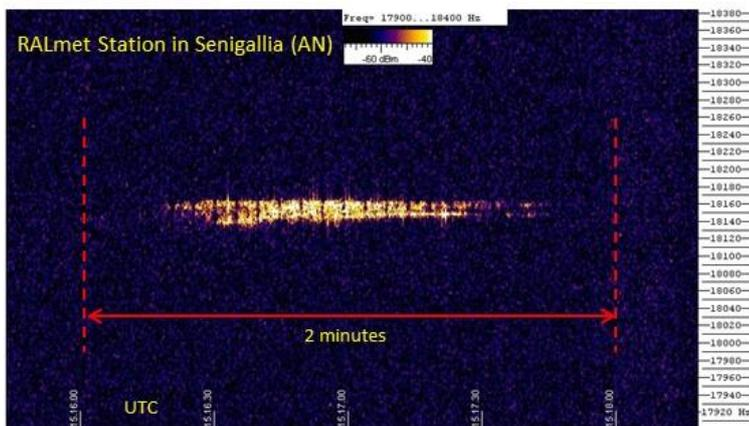

Remarkable event recorded on October 14, 2016

Radio reflection produced by the passage of a large (meteoric) object in the region of the sky "watched" by the antenna.

It is the most important event recorded by our station since the beginning of 2016.

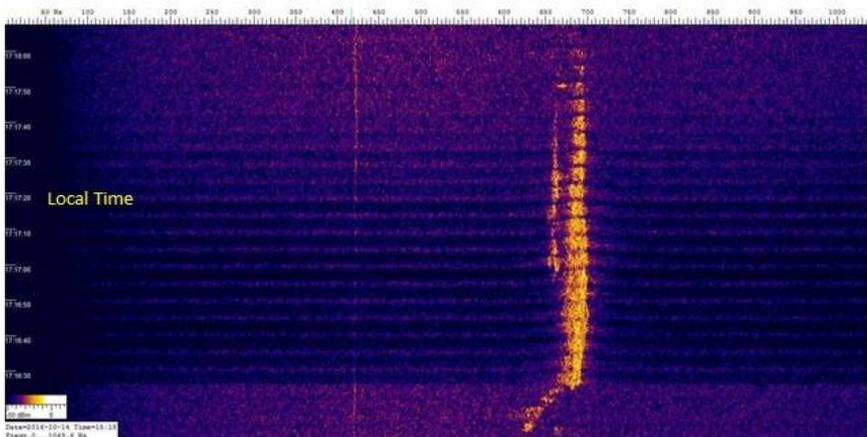

Recording of the same event performed by Florenzio Zannoni from Rome. Despite the technical differences between the radio stations, the lack of synchronization between the PC clocks and the different settings in the spectrograms visualization, there is a clear correlation between the two phenomena.

[Radio-meteoritic events December 2015](#)

[Radio-meteoritic events January 2016](#)

[Radio-meteoritic events February 2016](#)

[Radio-meteoritic events March 2016](#)

[Radio-meteoritic events April 2016](#)

[Radio-meteoritic events May 2016](#)

[Radio-meteoritic events June 2016](#)

[Radio-meteoritic events July 2016](#)

[Radio-meteoritic events August 2016](#)

In addition to the fixed station, it was built a different mobile receiving station, always tuned to the frequency 143.050 MHz, used occasionally for demonstration purposes during the recurring periods of major meteor showers.

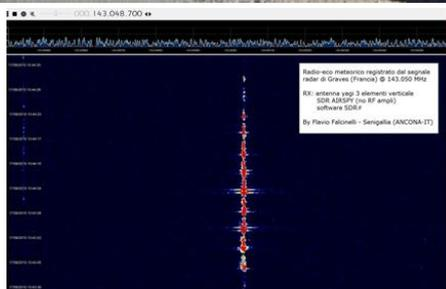

Registrazione radio-echi meteorici su spettrogramma



Antenna Yagi 3 elementi portatile



Ricevitore SDR commerciale

Elementi essenziali della stazione Meteor Scatter mobile (143.050 MHz con Graves TX).

Registrazioni dei radio-echi meteorici @ 143.050 MHz (radar Graves—Francia) più significativi nella giornata 10.08.2015

Recordings of the most significant radio-echo meteors @ 143,050 MHz (radar Graves-France) in the day 08/10/2015

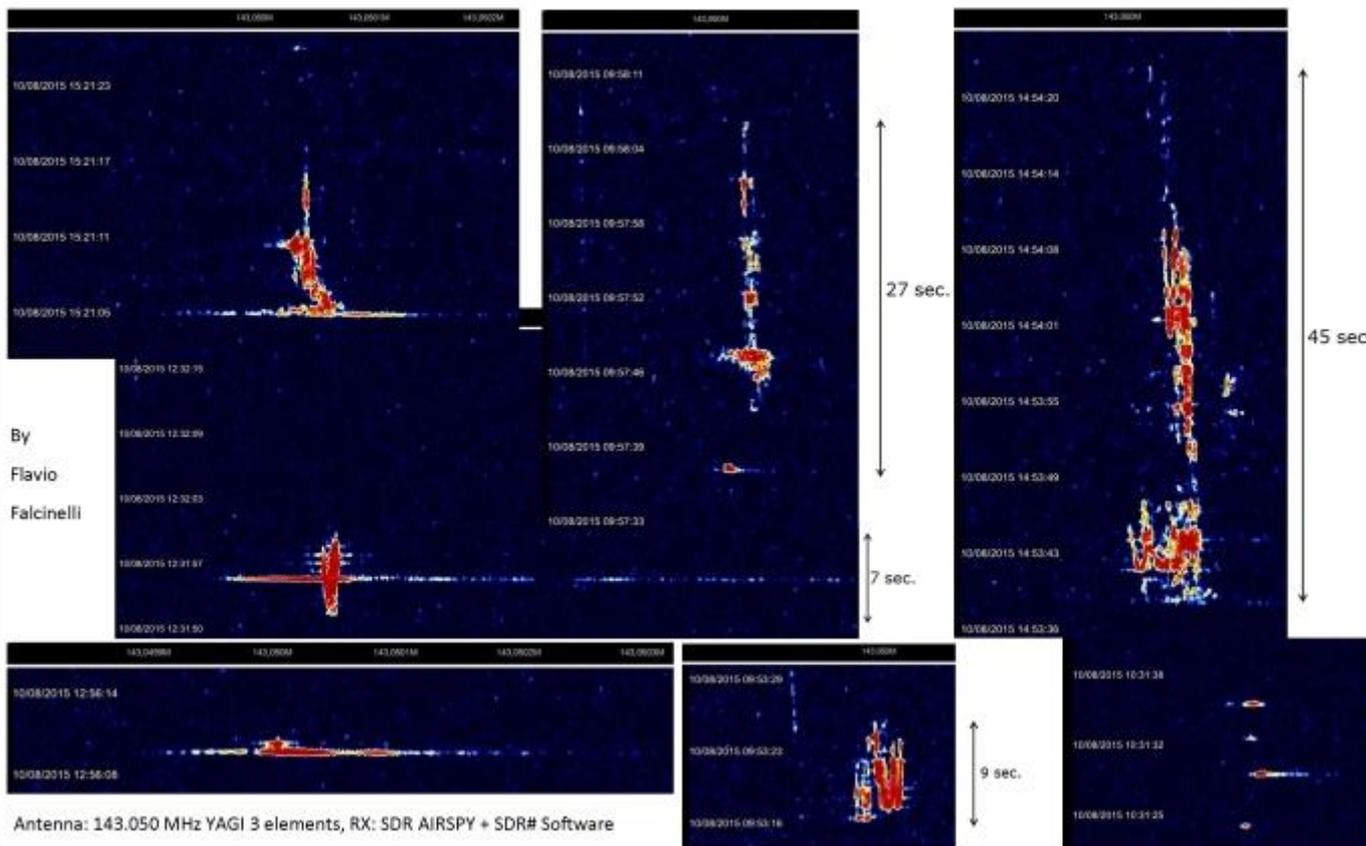

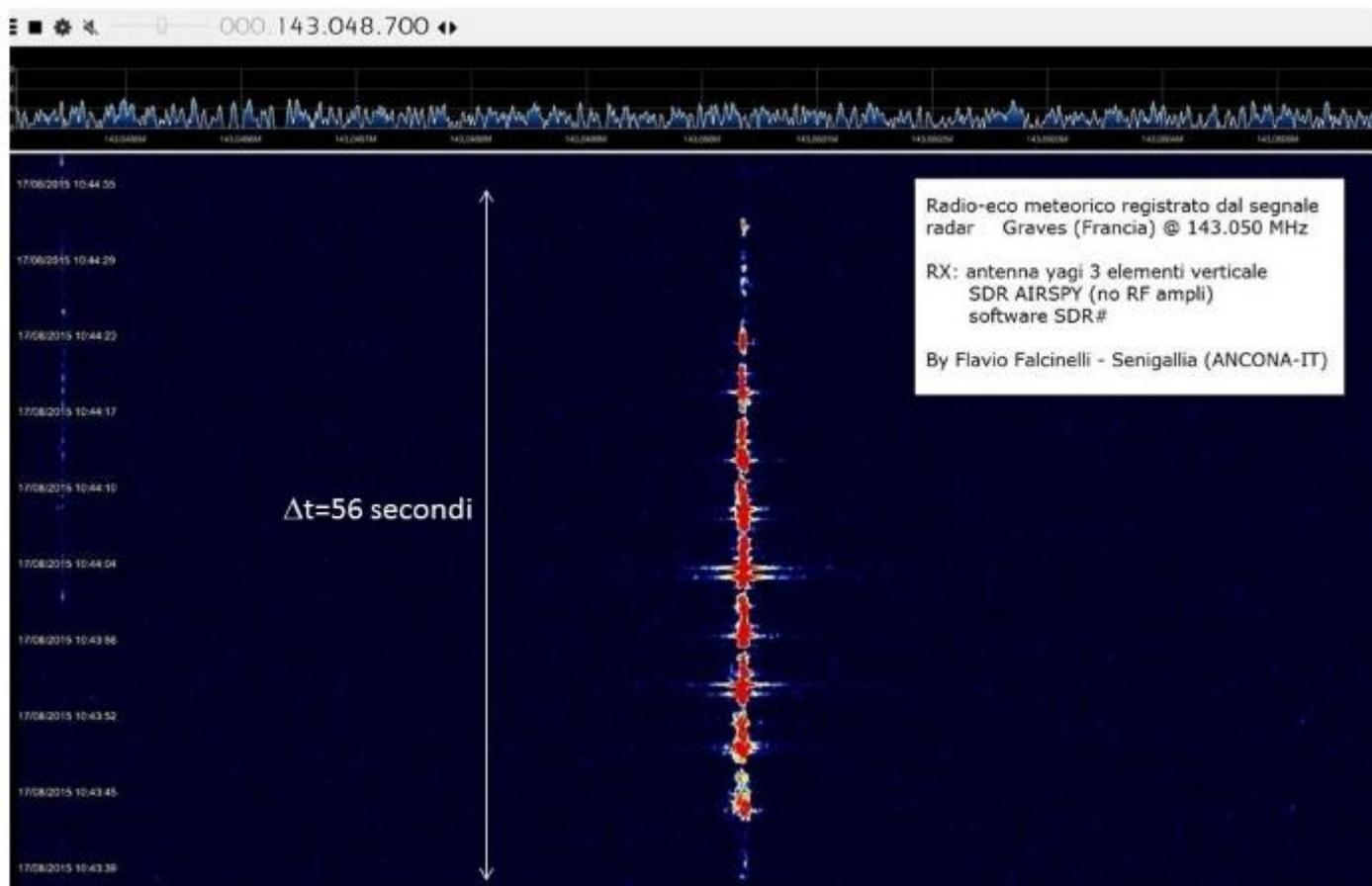

The mobile station includes a yagi antenna tuned on the 143.050 MHz frequency and positioned on the roof of a car via an adjustable support. The receiver is the SDR type that receives the supply voltage directly from the USB port of a laptop used for the acquisition.

The system is very simple, practical and economical, suitable for demonstrations "on the field" when the major meteor showers of the year recur: it is interesting and educationally useful to show the evolution of the meteor phenomenon in the radio band in parallel to the traditional visual observations.

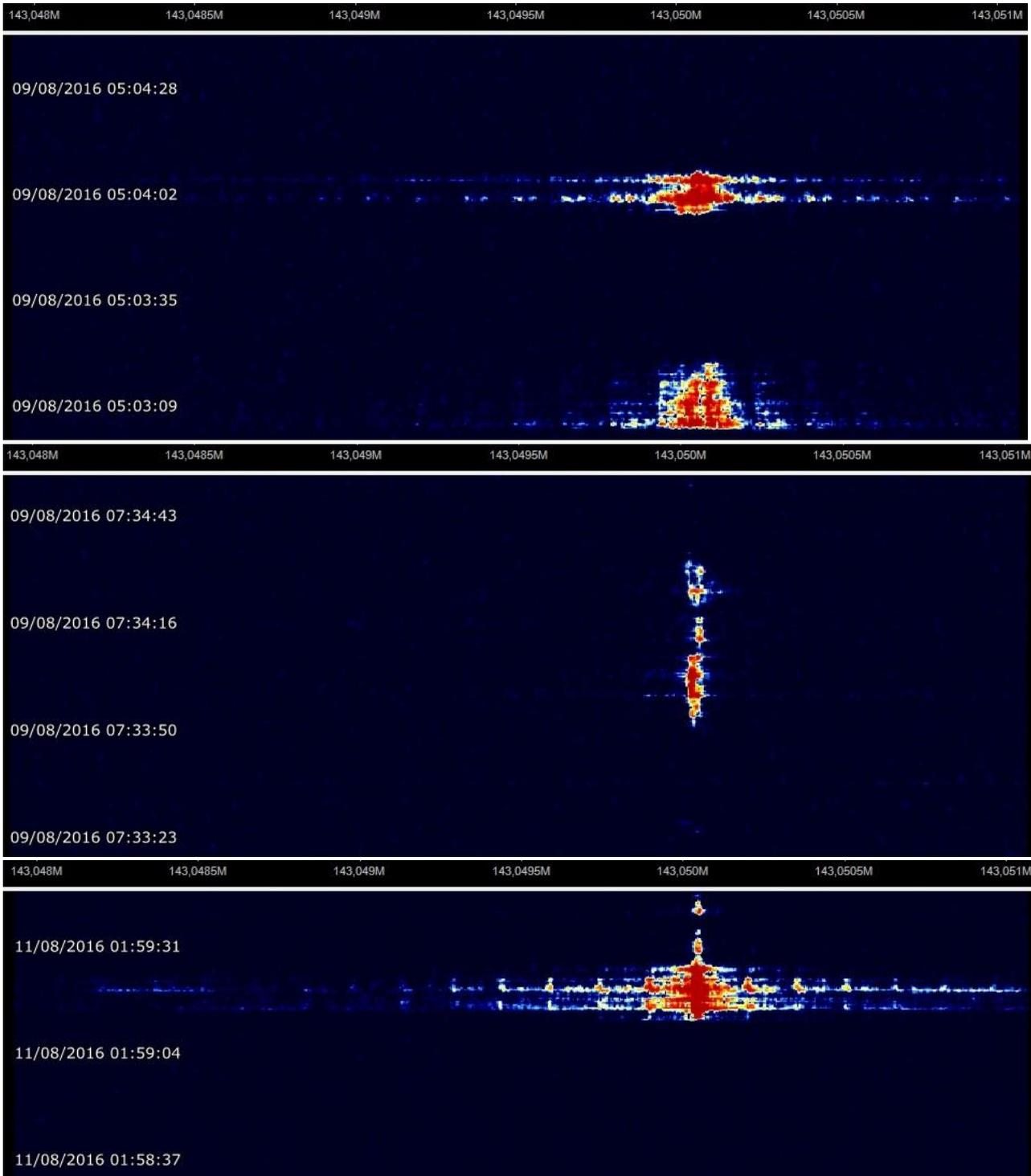

Recordings of remarkable meteor echoes acquired from our mobile station during the Perseids swarm 2016.

We report, in sequence, the most important radio-meteoritic events registered by our mobile station in the month of August 2016 (Perseids).

The metallic structure of the International Space Station (ISS) is able to reflect the radio signal transmitted from the Graves radar.

From the following pictures you can see the reflection of the radio signal that shows the transit of the International Space Station (ISS) over the Marche skies looking on the Adriatic sea (Senigallia-Ancona). It is clearly visible the Doppler shift in frequency of the reflected signal due to the movement of the object. Since the antenna of the receiver system (mobile station with Yagi 3 elements) is vertically oriented and situated not far from the ground and in a buildings screened area, the system is only sensitive to metal objects (or ionized trail of meteorites) passing near the local zenith.

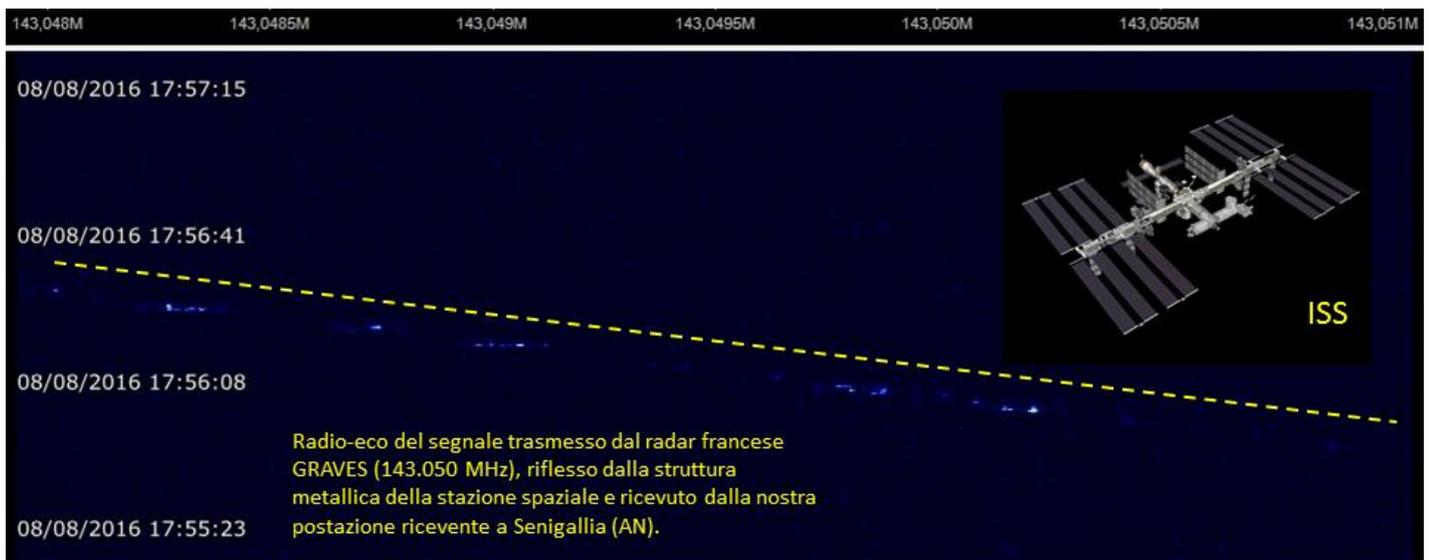

Transito della Stazione Spaziale Internazionale ISS sul nord Italia il 08.08.2016.

Segnale radio
 trasmesso dal Radar
 GRAVES 143.050 MHz

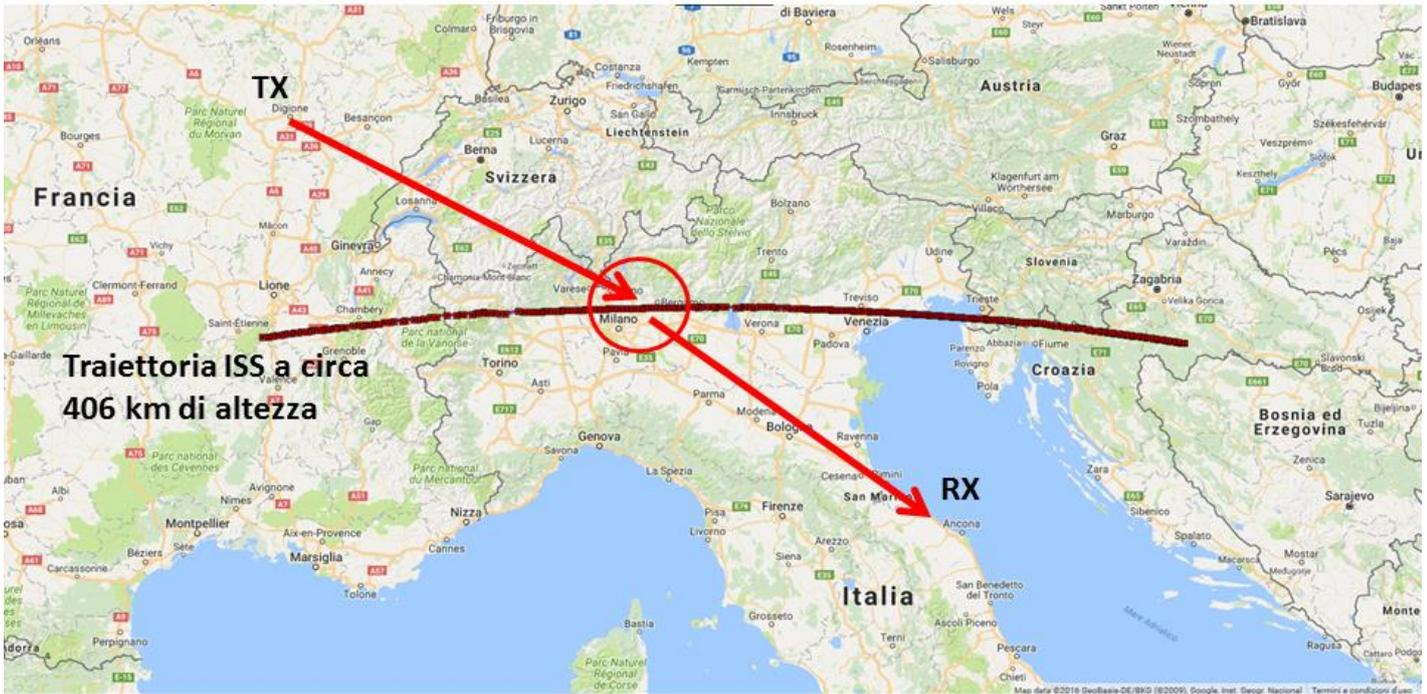

Segnale radio riflesso dalla struttura metallica della Stazione Spaziale Internazionale ISS e ricevuto dalla stazione di Senigallia (AN).

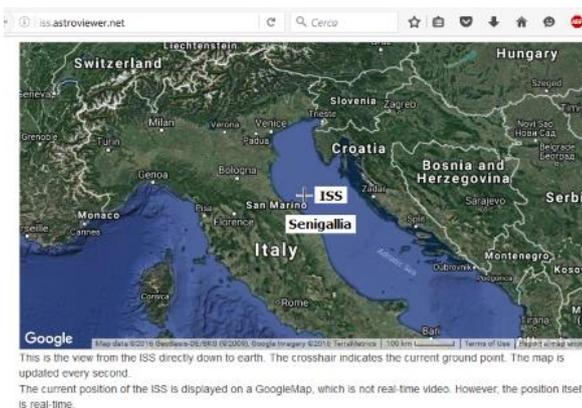

Ground track



Transito della Stazione Spaziale Internazionale ISS sopra i cieli marchigiani che si affacciano sul mare Adriatico (Senigallia - ANCONA)

11. The “special” frequency of the hydrogen

The line at 21 centimeters (1420.40575 MHz), due to the almost monochromatic emission of the "cold" hydrogen that populates the interstellar space (it is the most abundant element in the universe), was predicted theoretically by Van De Hulst in 1944 and discovered by H.I. Ewen and E.M. Purcell in 1951 as they watched a region of the Milky Way.

The event stimulated the search for other substances in the interstellar medium: so far, many complex molecules, including the organic ones, have been catalogued.

The study of 21 cm line is, rightfully, the first major and independent success of radio astronomy: through radio telescopes it was possible to "see" the spiral structure of the Galaxy, impossible for optical instruments because of the absorption of interstellar clouds.

Using *radio-spectrometers* is possible to determine with considerable accuracy the profile of the line as a function of frequency and, by applying Doppler techniques to the analysis of the data, you can achieve important information on the dynamics of the movement of large emitting masses of gas.

The "radio" study of the Galaxy structure is accessible at the amateur level: it is very interesting and instructive to define the shape of our galaxy investigating the distribution of gas and the characteristics of the 21 cm line profile. The relative transparency of the galactic disk at this frequency enables the "exploration" as a whole, while with optical means the observations are limited to a small region close to the solar system because of the strong absorption due to interstellar gas.



Ricevitore RALSpectrum
(prototipo):

Banda RX: 1240-1540 MHz.
 Singola conversione in banda-base
 [0-20 MHz] con uscite I & Q.
 Oscillatore Locale OCXO agganciato
 al GPS.

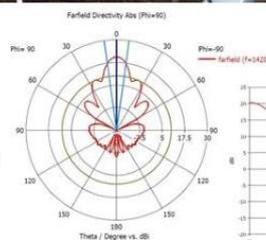

Radio-spectrometro sperimentale per 1420 MHz

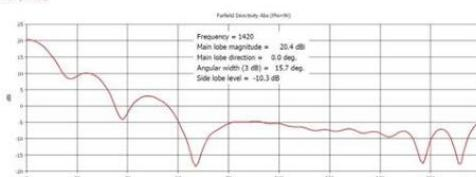

he images show our first telescope built to test this research possibility at amateur level. Browsing the web there are many well-documented examples of radio astronomy projects for the study of the 21 centimeters line.

The system consists of an antenna horn built with aluminum foil (we were inspired by the project detailed in <http://www.setileague.org/articles/horn.htm>) and supported by a wooden support, adjustable in elevation, assembled according to a classic amateur "philosophy" which favors the use of inexpensive and readily available materials (as long as you can ...).

The signal picked up by the antenna is amplified and filtered (LNA) to limit local interference, subsequently applied to the receiver (a prototype) that analyzes a portion of the bandwidth of the system, centered on the nominal value at rest of the hydrogen line (1420.40575 MHz).

The observations will highlight the doppler shifts of the rest frequency of the line, indicative of the relative motion of the gaseous masses with respect to the observer. For proper evaluation of the speed of movement, it is essential that the receiver is very stable in frequency: in fact a *radio-spectrometer*, which analyzes the spectrum of the signals within its bandwidth, must minimize the measurement errors caused by the receiver's and local oscillator's own drift (if the receiver is at frequency conversion).



This is the prototype antenna we built to study the sky at the neutral hydrogen frequency 1420 MHz. It is a typical amateur realization: the antenna is made with aluminum foil and installed on a wooden support manually orientable in elevation (fixed azimuthal orientation to the south). The support has been realized with a simple structure, recycling material from pallets normally used in the transportation of goods.



Amplifier (LNA) inserted between the antenna and the receiver. The device was constructed by connecting in cascade a band-pass filter centered on 1420 MHz, two commercial broadband amplifiers (low noise and high dynamic), further band-pass filter, identical to the previous one, connected to the output. The picture shows the frequency response of the amplifier.

In our prototype, called *RALSpectrum*, we treated carefully this requirement by using a local oscillator precise and heat stabilized (the receiver structure is at single frequency conversion, with quadrature mixer), coupled to the time reference signal from the GPS satellite network via an auxiliary receiver.

The first test is to orient the antenna on the zenith and... wait: if the system works, it should be clearly visible profile of the hydrogen line. The signal level will be minimal, given that the antenna "observes" a region of the sky away from the Milky Way where the gas is thickened.

The following images show some test recordings: more details on the structure of the radio telescope and the recordings can be found in the following animations.

https://www.radioastrolab.com/video/Hydrogen_1.webm

The purpose of our experiment was to test the functionality of an amateur radio telescope suited to the study of the profile of the neutral hydrogen line at 21 centimeters: in our tests we used, and built for the occasion, an antenna horn able to provide sufficient gain for the purpose.

Obviously, this is not the only or the best possible solution: larger antennas as, for example, parabolic reflectors with a diameter of about three meters, allow an easy reception of the hydrogen "monochrome" emission.

Particular attention was paid to the development of a radio-spectrometer characterized by a high sensitivity and stability, as requested by these applications. As we shall see, a receiver of this type is

used for other purposes such as, for example, in the development of an amateur SETI listening program.

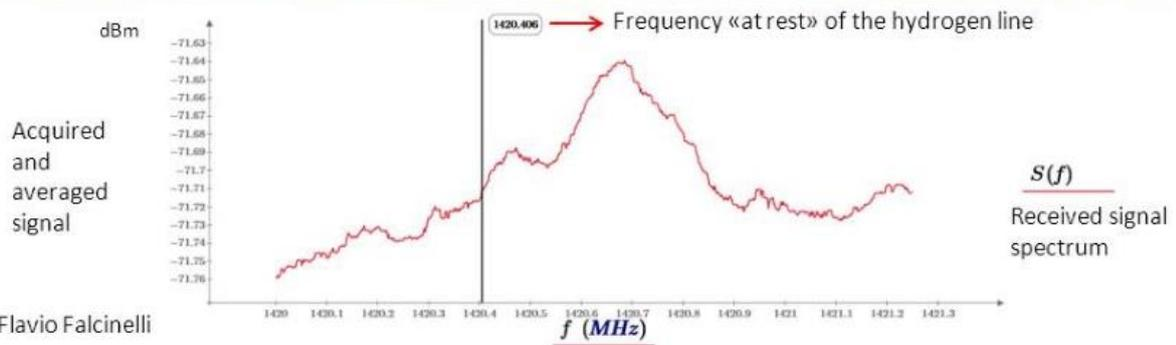
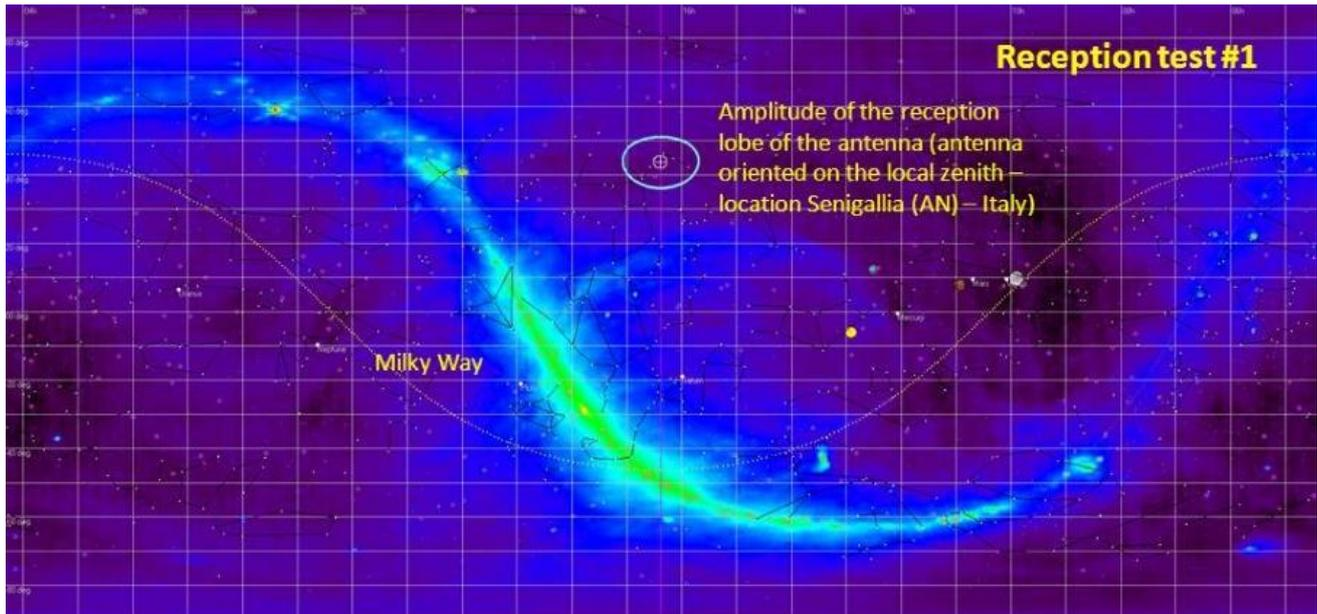

By Flavio Falcinelli

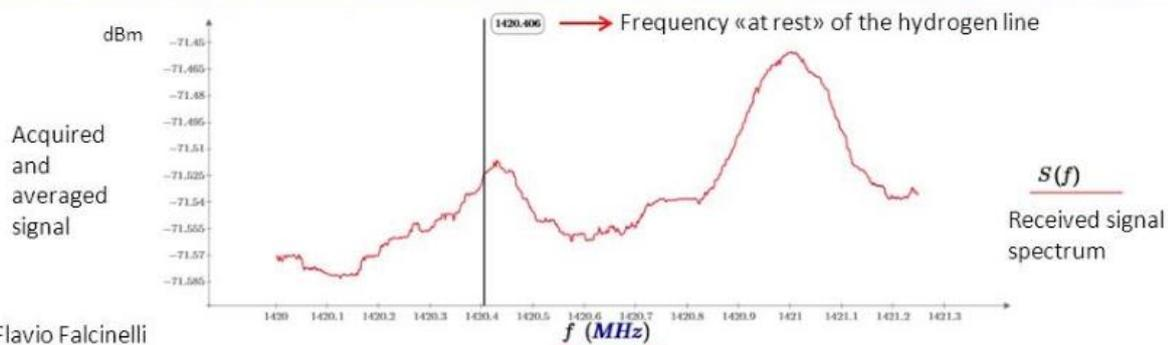
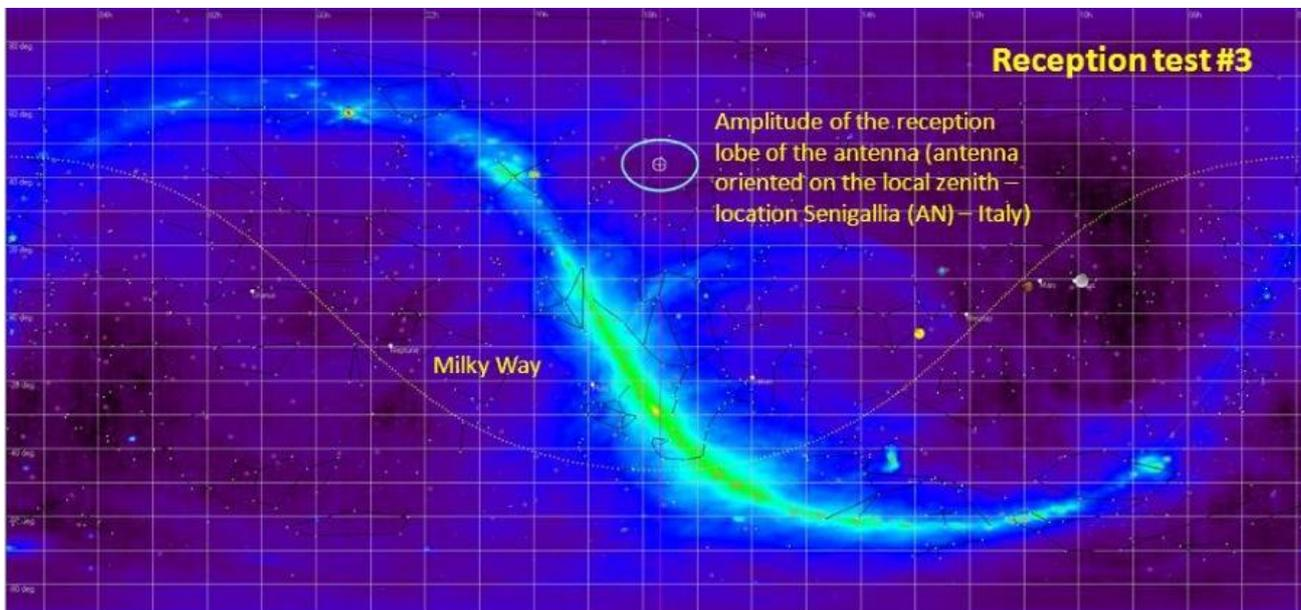

By Flavio Falcinelli

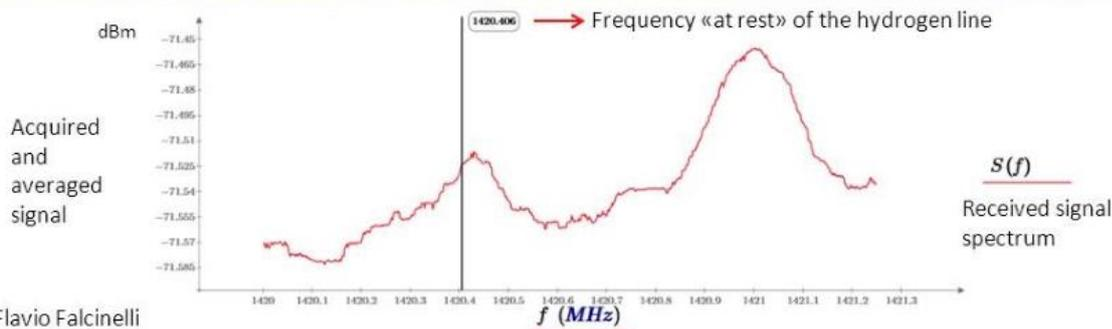
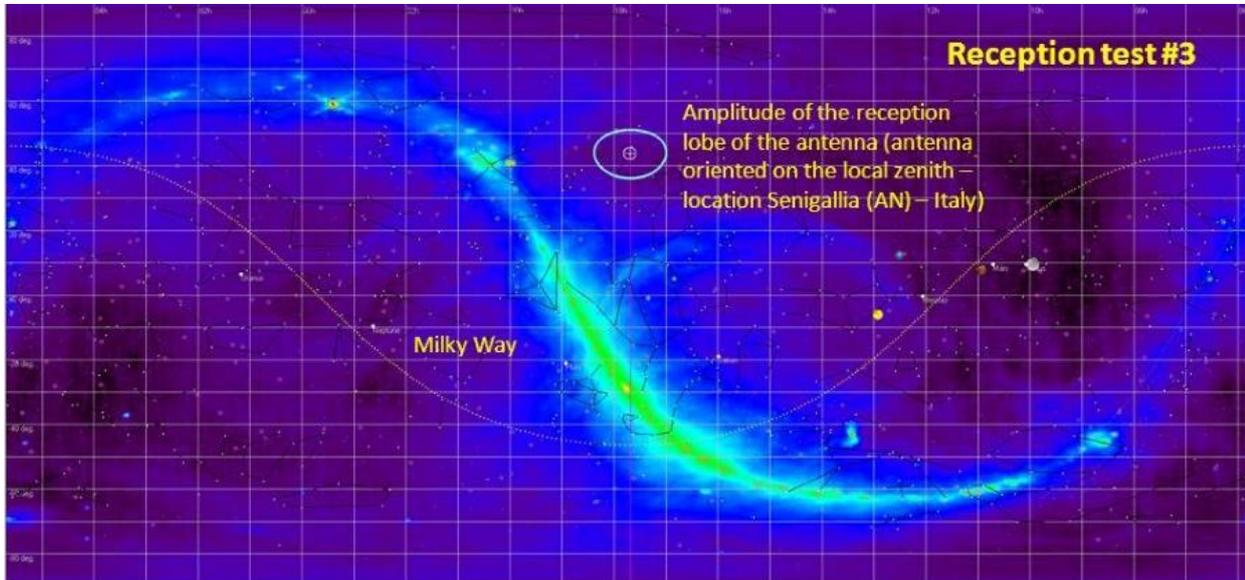

By Flavio Falcinelli

12. The “magic” band 1400-1600 MHz and the SETI researches

Radio astronomy enthusiasts are well aware that the frequencies around the hydrogen line (1420 MHz), with their receiving devices, are also used for S.E.T.I. researches (*Search for Extra-Terrestrial Intelligence*). These tools, in fact, are perfect to set up a SETI activity at amateur level, if one just optimizes and specializes the management and data analysis software.

The idea of assessing to what extent the radio waves emitted from the Earth are admissible in interstellar space came from two physicists at Cornell University, Giuseppe Cocconi and Philip Morrison: they have demonstrated, in a famous and innovative article of 1959, how the most suitable radio waves to propagate information in outer space are the ones next to the wavelength of 21 cm, the neutral hydrogen line. This frequency would be a "natural" tune easily distinguishable from the

background noise, known to every hypothetical extraterrestrial civilization. It represents "a unique and objective sample of frequency, necessarily known to any observer in the universe."

It is also reasonable to expect that receivers at this frequency are built from the beginning of the evolution of radio astronomy...".

In SETI's history, the article by Cocconi and Morrison explains the scientific motivations and represents the beginning of the search for extraterrestrials "smart" radio signals.

Subsequently were also offered other interesting frequencies corresponding to the spectral lines of molecules discovered in interstellar space, all valid for interstellar communications, since they have good chances of being accidentally revealed by hypothetical extraterrestrial civilizations during a scan of the sky, if not only to astrophysical interest.

Among the experts it is customary to identify with the suggestive name of "waterhole" the band from 1420 MHz to 1700 MHz, the water hole around which the galactic civilization gather, like animals in the jungle. The water, in fact, is formed from hydrogen (natural frequency of 1420 MHz) and the OH molecule (1665 MHz frequency): if it has an essential role in life and if we consider the technical advantages offered by interstellar communications in this frequencies band (the cosmic background noise is minimum), it is reasonable to start from these frequencies the search for possible extraterrestrial radio signals.

Much documentation is available on the web about the different philosophies and SETI search strategies, both academic and amateur level. There are also many groups of amateur radio astronomers involved in this type of research, sometimes coordinated by institutional radio-observers. The challenge is simply (so to say....) this: you need to gear up to receive very weak signals near the neutral hydrogen line. Fascinating activity, although a bit "nebulous"... The reasons that could stimulate a fan to invest resources and time in this work are:

- Intelligent extraterrestrial civilization distant no more than 100 light years, equipped with radio telescopes similar to that of Arecibo (diameter of about 500 meters), could transmit radio signals strong enough to be detected on Earth with amateur equipment, for example using parabolic antennas with a diameter of the order of 2-3 meters.
- Some amateur radio astronomer could have dumb luck....
- Continuing discoveries of new planets are documented (including Earth-like) external to our solar system.
- In interstellar clouds there have been discovered (thanks to radio astronomy) many complex organic molecules, such as those necessary for the chemistry of (our) life.
- The current technology provides the tools (radio telescopes), and analytical strategies of signals necessary to organize the first research efforts.