

electrorheology

ACCESSORY

ELECTRORHEOLOGY ACCESSORY (ER)

Electrorheological, or "ER", fluids are suspensions of extremely fine non-conducting particles in an electrically insulating fluid. These materials show dramatic and reversible rheological changes when the electric field is applied. The Discovery Hybrid Rheometer ER accessory provides the ability to characterize ER fluids up to 4,000 volts using either parallel plate or concentric cylinder geometries. The accessory is available for all DHR models and compatible temperature systems include the popular Peltier Plate (-40 °C to 200 °C) and Peltier Concentric Cylinder (-20 °C to 150 °C). A custom waveform and function generator enables the user to program a wide range of voltage profiles directly in TRIOS Software. Voltage Profiles include: constant voltage, step voltage, ramp voltage, sine wave voltage function, triangle wave voltage function, and wave functions with DC offsets. There are no limitations to the type or rheological experiments that can be performed with this accessory. A protective polycarbonate shield with trigger interlocks is also included with the accessory to provide safety from electrical shocks.

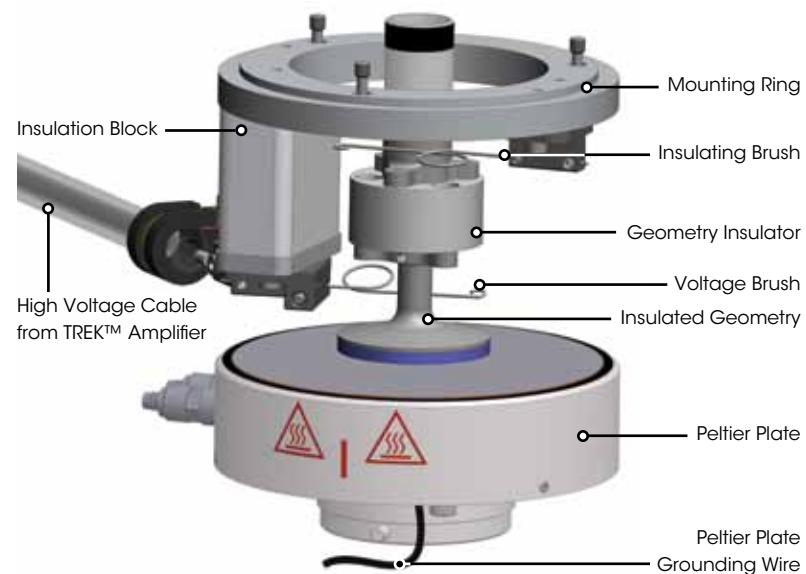

Features and Benefits

- Smart Swap™ technology
- Easy installation and removal
- Compatible with Peltier Plate and Peltier Concentric Cylinder
- 25 mm and 40 mm diameter plates with ceramic insulation
- 28 mm diameter DIN concentric cylinder rotor
- Wide voltage range: 4000 VDC, 4000 VAC (8000 V peak to peak)
- Compatible temperature systems
 - Peltier Plate: -40 °C to 200 °C
 - Peltier Concentric Cylinder: -20 °C to 150 °C
- Fully programmable from TRIOS Software
- Flexible voltage profile programming including:
 - constant voltage
 - step voltage, ramp voltage
 - sine wave voltage function
 - triangle wave voltage function
 - wave functions with DC offsets

DC Voltage Response of a Starch in Oil Suspension

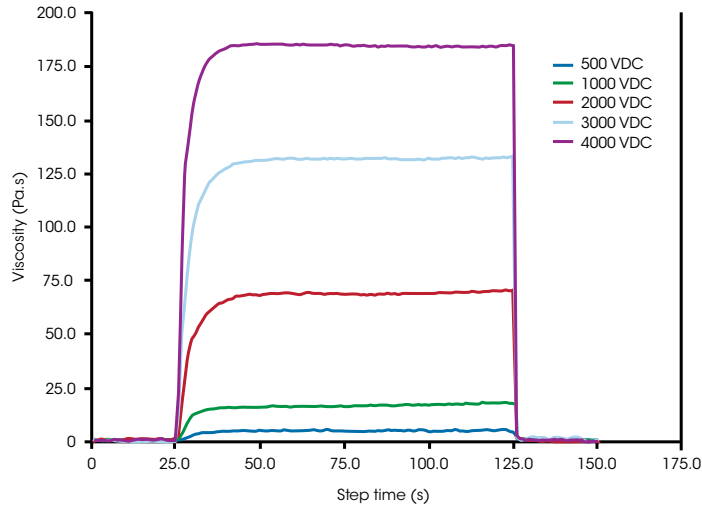

AC Voltage Response of a Starch in Oil Suspension

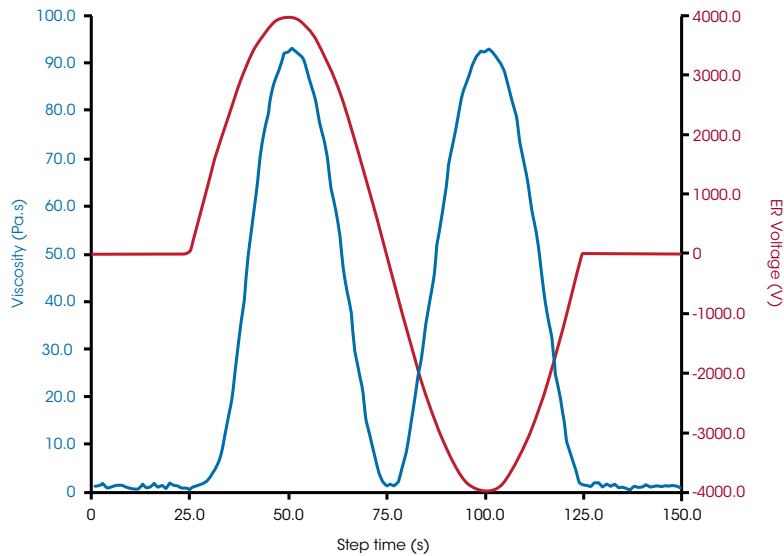

Step Voltage on Starch Suspension under Steady Shear

A 10% starch solution in silicon oil demonstrates dramatic and reversible changes in structure under the application of high voltage. The figure shows time dependent viscosity with varying DC voltage, from 500 to 4000 V, applied for 100 s. The underlying rheological test is a constant rate at 1 s^{-1} , which minimizes the disturbance to the structuring process. When an electrical field is applied, polarization of the starch particles in the non-conducting silicone oil leads to stringing of the starch particles, which align between the electrode plates. This orientation is responsible for the strong viscosity increase. The time to align the particles depends on the viscosity of the suspending fluid and the strength of the electrical field. Because under the applied shear rate, deformation of the structuring process is not completely eliminated, a maximum viscosity is observed when the dynamic equilibrium between forming and breaking of strings of aligned particles is achieved.

Sinusoidal Voltage Oscillation under Steady Shear

Electrorheological materials demonstrate interesting responses to AC voltage profiles. The figure to the left shows the viscosity response at a constant shear rate when an AC voltage with a peak maximum of 4000 V and a frequency of 0.01 Hz is applied to a starch in oil suspension. Under this applied electrical profile, it can be seen that the viscosity changes with twice the frequency of the voltage, or put another way, is in phase with the absolute value of the voltage. This behavior occurs because the viscosity is independent of the sign of the voltage. When the electrical field has zero voltage, the viscosity has the lowest value.