

The Journal of the
**Utah Academy of
Sciences, Arts, & Letters**

Volume 87 • 2010

**Includes selected and refereed articles from the
2010 Annual Conference
held at
Dixie State College
April 9, 2010**

Editor

Kristin L. Kraus

Copyright 2011, Utah Academy of Sciences, Arts, & Letters.
Copyright reverts to authors after publication. Printed in the United States of America by Brigham Young University Academic Publishing, Provo, Utah. Neither the editors nor the sponsoring organization assumes responsibility for statements of fact or opinion made by the contributors.

ISBN 978-0-9815501-4-5
All Rights Reserved

Board of Editors

Art: **Nichole Ortega**

Biological Science: **Erin O'Brien**

Business: **Jonathan H. Westover**

Education: **Joyce Sibbett**

Health, Physical Education, and Outdoor Recreation:

Shaunna McGhie

Letters, Humanities, and Philosophy: **Matias Martinez-Abeijon**

Letters, Language, and Literature: **Steve Peterson**

Physical Science: **Jean-Francois VanHuele**

Social Science: **Rob Reynolds**

2009-2010 Utah Academy of Sciences, Arts, & Letters Officers

President-Elect: **Nichole Ortega**

President: **Spencer Blake**

Past President-Elect: **Steve Turley**

General Secretary & Membership: **CoCo James**

Treasurer: **Karl Israelsen**

Publicity: **Peter Kraus**

Member at Large: **Dwight Israelsen**

Division Chairs

Art: **Nichole Ortega**, Utah Valley University

Biological Science: **Erin O'Brien**, Dixie State College

Business: **Jonathan H. Westover**, Utah Valley University

Education: **Joyce Sibbett**, Westminster College

Health, Physical Education, and Outdoor Recreation:

Shaunna McGhie, Utah Valley University

Letters, Humanities, and Philosophy: **Matias Martinez-Abeijon**,
Southern Utah University

Letters, Language, and Literature: **Steve Peterson**, Snow College

Physical Science: **Jean-Francois VanHuele**, Brigham

Young University

Social Science: **Rob Reynolds**, Weber State University

Member at Large: **Dwight Israelsen**, Utah State University

Cover Photo: Andrew Bishop

Utah Academy of Sciences, Arts, and Letters

History: Founded 3 April 1908, the Utah Academy of Sciences was organized "to promote investigations and diffuse knowledge in all areas of science." Beginning in 1923, the Academy started publishing the papers presented in its annual meetings in *Proceedings*. In June 1933 at the annual meeting, the Academy was enlarged to include arts and letters, and the name was changed to the Utah Academy of Sciences, Arts, and Letters. Articles of incorporation and non-profit organization status were accepted by the Academy membership at the spring meeting in April 1959. In 1977, the name of the journal of the Academy was changed from *Proceedings* to *Encyclia*. It became a refereed journal at this time. In the mid 1980s, the scope of the Academy was expanded further to include (1) business, (2) education, (3) engineering, (4) library information and instruction, and (5) health, physical education, and recreation. Beginning with the 1998 issue, the journal became *The Journal of the Utah Academy of Sciences, Arts, and Letters*.

Annual Meeting: The Academy's annual meetings are normally held in the spring on one of the Utah campuses of higher education. The plenary session is called the Tanner Lecture, endowed by Mr. O.C. Tanner in 1986.

Best Paper Awards: The best paper presented in every division is given a cash award, which is presented at the Academy's "Awards Evening" held the following fall.

Distinguished Service Awards: The Academy recognizes outstanding contributions to teaching and scholarship by means of annual Distinguished Service Awards, alternating every other year between disciplines.

Membership: When the Academy was founded in 1908, membership was by nomination, ratified by the Council, and elected by a "three-fourths votes of members present." Today, the Academy's membership is available by application.

Institutional Members: All Utah institutions of higher education are members of the Utah Academy. The Academy appreciates their patronage.

PUBLICATION POLICY

Papers published in *The Journal of the Utah Academy of Sciences, Arts, and Letters* are drawn from papers presented by members in good standing at the annual conference of the Utah Academy. To qualify for publication, the papers must be recommended through a refereeing system.

Presenters are encouraged to publish their paper in *The Journal of the Utah Academy*. *The Journal's* criteria are that a submission is (1) fresh, meaningful scholarly insight on its subject; (2) readable and well written; and (3) of general interest for an academic readership beyond the author's field.

If you wish your paper to be considered for publication in *The Journal*, please send one hard copy of your paper and abstract to Spencer Blake, Sociology Dept. TBF, Salt Lake Community College, 4600 South Redwood Road, Salt Lake City, UT 84123, and three copies to the chair of your division by May 1, 2010. All submitted papers will be considered for an Outstanding Paper Award. Include both your institutional and home addresses and phone numbers, email address and fax number. Papers will be peer reviewed. Please suggest possible appropriated referees, including names, telephone numbers and addresses.

At the time of acceptance for publication, manuscripts must be submitted as an attachment in Microsoft Word via email, also attach a PDF. Figures, diagrams and photographs must be saved as TIFF files and should be no larger than 5 x 7. Papers must conform to the style of the paper's discipline: MLA, APA, Chicago, CBE, or AIP. Papers should be between ten and twenty double-spaced pages.

The Journal of the Utah Academy is a refereed journal. Editorial responses will be forthcoming after the resumption of school the following fall when referees have returned their comments to the division chairs.

Detailed publication guidelines are available at the Utah Academy website: www.utahacademy.org.

Among the bibliographic services listing at Bowker Serials Bibliographies and The Standard Periodical Direction. Indexing and abstracting services that cite articles in the journal include Arts and Humanities Citation Index, Biosciences Information Services, Current Geographical Publicatoin, Chemical Abstracts, Mathematical Reviews, MLA Biography, Sociological Abstracts, Excerpta Botanica, Social Planning, Policy and Development Abstracts, Language and Language Behavior Abstracts, Index to Scientific Technical Proceedings, and Index to Social Sciences, and Humanities Proceedings.

The Journal of the
**Utah Academy of
Sciences, Arts, & Letters—2010**

AWARDS

Distinguished Service Award	11
Academy Fellow 2010	13
John and Olga Gardner Prize	14
Tanner Lecture	15
Awards Evening Lecture	16
Honorary Member	17
2010 Best Paper Awards	19

ARTICLES

ARTS

World War in the Wasatch Mountains	23
Stephen B. Armstrong, <i>Dixie State College</i>	
InterPlay: Performing on a High-Tech Wire (Collaborative, Real-Time, Distributed, Surrealistic Cinema)	29
Elizabeth Ann Miklavcic and Jimmy Miklavcic, <i>Another Language Performing Arts Company University of Utah Center for High Performance Computing</i>	

BIOLOGICAL SCIENCES

- Emerging Infectious Disease Chytridiomycosis and the Significance of the Absence of *Batrachochytrium dendrobatidis* on *Hyla arenicolor* in Zion National Park** 49
Allystair D. Jones, Daniel J. Sumko, and Curt Walker, *Dixie State College*

BUSINESS

- The Risk That Wasn't There: Understanding the Role of Derivatives on Reducing and Creating Risk** 57
Leo Chan, *Utah Valley University*
- Complex Job Structure and Intelligence: A Research Proposal** 69
Christopher Michael Nelson, *Utah Valley University*
- Engaged Learning and the Entrepreneurial Mind Set** 87
Peter B. Robinson, *Utah Valley University*

EDUCATION

- The Weakening of Tenure and Post-Tenure Review: An Issue Analysis** 111
John Hill, *Salt Lake Community College*
- Westminster College's Master of Arts in Teaching and YouthCity: An Effective After-School Partnership** 121
Joyce Sibbett, Shamby Polychronis, and Elizabeth Robinson Rich, *Westminster College*

ENGINEERING

- 3-D Numerical Simulations of Liquid Laminar Flow at Re=1 over Super-hydrophobic Surfaces with Post Geometries** 129
Abolfazl Amin, *Utah Valley University*

**HEALTH, PHYSICAL EDUCATION, AND
RECREATION**

- A Correlation between Collegiate Baseball Players’
Posture and Individual Baseball Statistics** 145
Bret Boyer, Corey Rankin, Leoni Lobendahn, Jason Slack,
Mike Bohne, *Utah Valley University*

- Comparable Study: Running the 1.5-mile Run on a
Treadmill Vs. Running the 1.5-mile Run on an Indoor
Track** 151
M. Vinson Miner and Jason Slack, *Utah Valley University*

LETTERS—PHILOSOPHY

- Pedro Salinas’s Theory of Tourism** 157
Andrew Bishop, *Brigham Young University*

- The Women in Parzival: An Experiment in Jungian
Literary Criticism** 197
James W. Harrison, *Southern Utah University*

- Parzival and the Hero Cycle** 225
Jessica Pierce, *Southern Utah University*

LETTERS—LITERATURE

- Victory of the Ash Buttocks: The Role of Hybridity in
Colonization, Decolonization, and Postcolonization** 235
Jennifer Gibb, *Dixie State College*

- A Mean and Ungentlemanly Act: Casaubon’s Passive
Aggressive Maneuvering in George Eliot’s Middlemarch** 245
Randy Jasmine, *Dixie State College*

PHYSICAL SCIENCES

Measurement of the Imaginary Index of Refraction of UO_x in the Extreme Ultraviolet 255

Heidi M. Dumais, R. Steven Turley, and David D. Allred,
Brigham Young University

Persistence of Magnetic Domain Memory Through Field Cycling in Exchange Bias Thin Films 267

Joseph Nelson, Brian Wilcken and Karine Chesnel,
Brigham Young University

SOCIAL SCIENCES

Rare, Though it Shouldn't Be: A Virgin's Perspective on Sexual Activity 275

CoCo James, Andrea Santurro, and Spencer Blake, *Salt Lake Community College*

Americanization of Russian Culture and Its Effects on English Language Acquisition in that Country 283

Olga A. Pilkington, *Dixie State College*

Reassessing American Foreign Policy Amidst the Maelstrom: The Last Superpower? Revisiting the Paradigm of Imperial Decline 293

G. Michael Stathis, *Southern Utah University*

The Economics of Geographical Ward Boundaries in the LDS Church 317

Daniel Robertson and Tyler Bowles, *Utah State University*

ABSTRACTS 337

DISTINGUISHED SERVICE AWARD

Dr. Harold McNamara

Brigham Young University

D. Harold McNamara was born in Salt Lake City and was educated in Salt Lake City schools. He attended the University of California, Berkeley, where he received his B.A. (1947) and Ph.D. (1950). During his career, Dr. McNamara was a professor at Brigham Young University from 1955 until 2007, a Guest Investigator at many different observatories, and Managing Editor of two different publications. He has authored or co-authored more than 100 publications and has presented in different countries around the world. Dr. McNamara received the Karl G. Maeser Research Award in 1966, the Fourth Distinguished Annual Faculty Lecture from Brigham Young University in 1967, the Wesley P. Lloyd Memorial Award in 1982-83, and the George Van Biesbroeck Prize in 2000. Dr. McNamara also served in the United States Navy during World War II (1943–1946), and retired as a Lieutenant JG. He is the father of 3 children and grandfather of 19 grandchildren.

DISTINGUISHED SERVICE AWARD

Dr. Andrew Barnum

Dixie State College

Dr. Andrew H. Barnum was born in Mesquite, NV, and moved to St. George as a child. He attended Dixie Jr. College (A.S.), Brigham Young University (B.A. and M.A., *summa cum laude* for both), and Iowa State University (Ph.D.) and completed post-doctoral studies at Arizona State University. Dr. Barnum has been a part of the Dixie State College of Utah community since 1959. During his tenure at Dixie State College, Dr. Barnum has been a professor, Division Director of Biological Sciences, Dean of Natural Sciences, Dean of Administration, and Vice President and Director of the College's Natural History Museum. He was also recognized by the U.S. Department of Agriculture as one of the three top entomology specialists in the United States. He has made significant contributions to BYU through donations of a valuable collection of beetles and another of grasshoppers, each numbering more than 10,000 specimens, to be used in advanced study and research. Since Dr. Barnum's retirement in 1995, he has worked as an unpaid volunteer for the college, running the Department of Biological Sciences introductory laboratory classes and continuing his work as director of the Museum. In addition, Dr. Barnum volunteers his time identifying cases of West Nile Virus for Washington County and classifying orthopteroid insects for both the Monte L. Bean Museum (BYU) and the C.P. Gillette Museum of Arthropod Diversity (Colorado State). Dr. Barnum published one of his first papers with the Utah Academy in 1953.

ACADEMY FELLOW 2010

Dr. Ted Warner

Brigham Young University

Dr. Ted J. Warner, Professor Emeritus of History at Brigham Young University, received his B.A. and M.A. at BYU and his Ph.D. at the University of New Mexico. He taught history at BYU for 32 years. Altogether he taught for 39 years, including two years at the College of Eastern Utah, one year in London, one year in Madrid, one year in China, and two years at the Joseph Smith Academy in Nauvoo, Illinois. His major area of teaching and research was the Spanish Borderlands—that part of Northern Mexico and the Southwestern part of the United States that the Spaniards explored, colonized, and exploited. Dr. Warner served in administration duties at BYU as History Department Chairman, Dean of the College, and Director of International Programs. He has been married for 56 years to Dr. Doris S Warner, a retired teacher who taught for 42 years!

JOHN AND OLGA GARDNER PRIZE

Michael Ballum

Utah Festival Opera

Michael Ballam has received critical acclaim with the major opera companies of the U.S. and a recital career in the most important concert halls of every continent. His operatic repertoire includes more than 600 performances of over 70 major roles, sharing the stage with the world's greatest singers. At the age of 24, Mr. Ballam became the youngest recipient of the degree of Doctor of Music with Distinction in the history of Indiana University. An accomplished pianist and oboist, he is the Founder and General Director of the Utah Festival Opera, which is fast becoming one of the nations major opera festivals. A Professor of Music at Utah State University, he is the author of over 40 publications and recordings in international distribution, has a weekly radio program on Utah Public Radio, starred in three major motion pictures and appears regularly on television, and serves on the Board of Directors of 12 professional arts organizations.

TANNER LECTURE

Power, Place and Prejudice

W. Paul Reeve

University of Utah

“By 1866, the power for making space in southwestern Utah Territory shifted far afield from local Mormon, miner, or Paiute control to the halls of Congress. A hierarchy of power emerged that privileged Nevada's mining frontier over Mormons and Paiutes and that built borders to enforce its prejudices. . . . The mere promise of silver hidden in a small spot of ground, possibly in Utah Territory, was enough to lift a 300 mile long border and toss it fifty miles east.”

W. Paul Reeve is Associate Professor of History at the University of Utah and Associate Chair of the History department, where he teaches Utah history and history of the U.S. West. He is on the board of editors of the Utah Historical Quarterly, the governing board of the Mormon History Association, and the Faculty Advisory Council of the University of Utah Press. The University of Illinois Press published his first book, *Making Space on the Western Frontier: Mormons, Miners, and Southern Paiutes*, in April 2007. The Mormon History Association awarded *Making Space* the Smith-Pettit Best First Book award in 2008. In 2007 Reeve was awarded a Mayers Research Fellowship at the Huntington Library in San Marino, California and a Virgil C. Aldrich Research Fellowship at the Tanner Humanities Center at the University of Utah. He is researching 19th-century notions of Mormon physical otherness, including ways in which outsiders racialized Mormons and a corresponding Mormon effort to claim whiteness for themselves. His future book on the subject, *Religion of a Different Color: Race, Whiteness, and Mormon Bodies*, is under contract with Oxford University Press. His Tanner Lecture explores the strange series of events touched off when a Southern-Paiute-Indian-agent-turned-pro prospector discovered silver in a remote Nevada desert in 1865. Before it ended, Congress intervened to make decisions that impacted southern Utah Mormons, Southern Paiutes, and the very shape of Utah.

AWARDS EVENING LECTURE

Dr. Brandie R. Siegfried

Brigham Young University

Dr. Brandie R. Siegfried is Associate Professor of English at Brigham Young University. She received her B.A. and M.A. in English and American literature at BYU. She went on to complete a Ph.D. in English and American literature at Brandeis University, where she also finished an additional M.A. in Women's Studies. In her 17 years professing 16th and 17th century English literature and culture, she has received numerous research and teaching awards. She specializes in Shakespeare but also teaches and publishes on a variety of poets, essayists, and dramatists of the Renaissance. Her various publications address topics such as the conflict between theories of chance and probability in the 17th century; the philosophies of art in 16th century drama, painting, and book illustration; and the theological implications of 16th and 17th century theories of science. One of her forthcoming books, *'The Rational Soul': Science, Philosophy, and the Idea of God in the Works of Margaret Cavendish*, includes essays by several of the foremost current thinkers on the Cavendish circle's influence on developments in 17th century natural philosophy. In addition, Prof. Siegfried has served as President of the International Margaret Cavendish Society, an academic group which explores the interrelations of literature, art, and science in the later English Renaissance. She is currently president-elect of the Queen Elizabeth I Society. On a more personal note, she loves cycling, skiing, tennis, fencing, shooting, and knife throwing. She is an avid reader of detective fiction, enjoys R&B music, and is currently teaching herself classical guitar. Originally from Oregon, she occasionally misses the ocean, but finds the beauty of Mt. Timpanogos to be every bit as ravishing.

HONORARY MEMBER

Paul Rolly

Salt Lake Tribune

Paul Rolly is a life-long resident of Salt Lake City and graduated from the University of Utah with a B.S. in political science with a minor in journalism. He has worked at the *Salt Lake Tribune* since 1973, except for a three-year interruption in the early 1980s, when he joined the Salt Lake City bureau of United Press International as UPI's state government and political reporter as well as the Utah Correspondent for UPI's national political report. He also spent a year as bureau chief. When he returned to the Tribune, he was the state government, legislative, and political reporter. He was named business editor of the Tribune in 1990, but after a year was persuaded to start a column with JoAnn Jacobsen Wells, called "Rolly and Wells." Since Wells retired in 2004, Rolly has written the column solo. He also writes a Sunday column for the *Tribune's* Opinion section focused on local politics. He has been a correspondent for the *Wall Street Journal* and has taught a column-writing class at Weber State University. He also served on the board of the Utah Chapter of the National Society of Professional Journalists and served as its president for one year. He is married to Dawn House, who also works at the *Tribune* as a business reporter.

2010 BEST PAPER AWARDS

Arts

Interplay: Performing on a High-Tech Wire

Elizabeth Ann Miklavcic and Jimmy Miklavcic

University of Utah

Biological Science

Emerging Infectious Disease Chytridiomycosis and the Significance of the Absence of *Batrachochytrium dendrobatidis* on *Hyla arenicolor* in Zion National Park

Allystair Jones, Daniel J. Sumko, and Curt Walker

Dixie State College

Business

Engaged Learning and the Entrepreneurial Mindset

Peter B. Robinson

Utah Valley University

Education

The Weakening of Tenure and Post-Tenure Review: An Issue Analysis

John Hill

Salt Lake Community College

Health Sciences and Outdoor Recreation

Comparable Study: Running the 1.5-Mile Run on a Treadmill vs. Running the 1.5-Mile Run on an Indoor Track

M. Vinson Miner and Jason Slack

Utah Valley University

Physical Science

**The Persistence of Magnetic Domain Memory Through
Field Cycling in Exchange Bias Thin Films**

Joseph Nelson and Karine Chesnel
Brigham Young University

Letters: Literature/Language

**A Mean and Ungentlemanly Act: Casaubon's Passive
Aggressive Maneuvering in George Eliot's
Middlemarch**

Randy Jasmine
Dixie State College

Victory of the Ash Buttocks

Jennifer Gibb
Dixie State College

Letters: Humanities/Philosophy/Foreign Language

Pedro Salinas' Theory of Tourism

Andrew Bishop
Brigham Young University

World War in the Wasatch Mountains

Stephen B. Armstrong
Dixie State College

Abstract

In 1967, director Andrew V. McLaglen came to Utah to shoot a World War II adventure film with actors William Holden, Vince Edwards, and Cliff Robertson. Titled The Devil's Brigade, the motion picture chronicles the efforts of American and Canadian troops as they struggle to drive Nazi forces out of the Italian Alps. For the picture's climactic sequence, McLaglen and the film's producer, David L. Wolper, set up their cameras in and around the Wasatch Front, exploiting the area's soaring cliffs and sweeping views. This paper traces the production history of The Devil's Brigade, providing information about the filmmakers' reasons for choosing the Wasatch region as a production location and the challenges they experienced shooting their movie in this rugged section of our state.

Released in 1968, *The Devil's Brigade* is a World War II-era adventure film that follows a group of soldiers who train for and eventually lead a pair of dangerous assaults in the Italian Alps. Much of the outdoor footage that appears in the picture was shot in the mountains that surround Salt Lake City, Utah.

A brief summary of the film's plot may be helpful. *The Devil's Brigade* opens in the summer of 1942, as Robert T. Frederick, a lieutenant colonel in the United States Army, is told to create a special fighting unit comprised of Canadian and American soldiers. Called the 1st Special Service Force, the group is charged with driving the Nazis out of Norway. Given only four months to prepare the men, Frederick faces numerous obstacles: While the Canadians are all exemplary soldiers, the Americans are criminals and miscreants.

Training in Montana, the soldiers eventually become adept at hand-to-hand combat, skiing, and mountain climbing. Then Frederick learns that the mission to Norway has been cancelled. Hating to see his men's efforts go to waste, the lieutenant colonel persuades his superiors in Washington to send the men to Italy to conduct a raid on a small mountain town held by the Germans. The attack is successful, and the soldiers bring back several prisoners. During an interrogation, a captured officer refers to Frederick's soldiers as devils, and thereafter the members of the 1st Special Service Force call themselves "The Devil's Brigade." The men's prowess subsequently lands them another assignment. This time, they are sent to knock out a battalion of Germans who occupy a mountain along the route to Rome.

The Devil's Brigade was directed by Andrew V. McLaglen, a prolific American filmmaker who may be best remembered for making Westerns like *Shenandoah* (1965) with Jimmy Stewart and *Chisum* (1970) with John Wayne. David L. Wolper served as the film's executive producer, his first venture into motion picture production. Previously, Wolper had established himself as a television producer, with credits that included several notable documentaries about the Second World War: *D-Day June 6, 1944* (1962); *France: Conquest to Liberation* (1965); and *Prelude to War* (1965).

In his memoir *Producer*, Wolper explains that he became interested in making a feature about the 1st Special Service Force after "an agent sent me the manuscript of a book...entitled *The Devil's Brigade*," by Robert Aldeman and George Walton. "It was a terrific story and I made a deal with United Artists to produce it" (Wolper, 161). It should be noted that Aldeman and Walton's book was based on actual events. For the script, Wolper hired William Roberts, who had written the screenplay for John Sturges's *The Magnificent Seven* (1960), which, like *The Devil's Brigade*, tells the story of a unit of fighting men who

face a nearly impossible challenge. Wolper and McLaglen managed to put together an all-star cast for the film, signing Vince Edwards, Cliff Robertson, and William Holden, who played the lead role of Lt. Colonel Frederick.

The filmmakers arrived in Utah to shoot their picture in the spring of 1967, drawn by the state's stunning Wasatch Front area. The Montana camp where Frederick first organizes his men, for example, is in fact Camp W.G. Williams, a training facility administered by the Utah National Guard in Riverton, and the Italian mountain where the soldiers subdue the enemy in the movie's climactic sequence was actually shot east of Draper in the Lone Peak Wilderness Area, on Lone Peak's mountain summit. *The Salt Lake Tribune* notes that Wolper and McLaglen "persuaded the Utah National Guard to grade a road up a steep ridge to the spectacular Jacob's Ladder area on Lone Peak's south slope." ("Andrew McLaglen Keeps Control at all Times"; "Cops Break Out Heavy-Duty Machines"). The road was used to transport cast, crew, and equipment to the mountaintop. The producers leased a helicopter as well (Thomas, 160).

Salt Lake City served as home for the cast and crew when they weren't shooting. The film's director Andy McLaglen was an enormous boxing fan, and on his first night in town, after checking into his hotel, he headed out to the Valley Music Center in Bountiful to watch West Jordan native Don Fullmer in a bout. After the match, McLaglen approached the fighter and invited him and his brother Gene, another boxer, to appear in the picture. The two accepted the offer and can be seen in a barroom brawl sequence that appears about a third into *The Devil's Brigade*. This sequence, incidentally, was filmed in the National Guard armory in Lehi ("Now Meet Andy McLaglen").

Although conditions on the mountains were windy and cold when the filmmakers were photographing exterior sequences, shooting generally went smoothly. Leading man William Holden, however, was an alcoholic, which proved to be an occasional problem for McLaglen. The director recalled that "when the actor was drinking, his whole personality changed. He became garrulous, talkative, loud, outgoing. His performance, which at most times would be a hundred percent, became inept. He tottered on his feet, steeling himself to say the dialogue. Usually he made it through. I had to reshoot only one scene because he was drunk" (Personal interview). Ironically, the scene that McLaglen had to reshoot follows the barroom brawl sequence in which the Fullmer brothers appear. Holden's character actually scolds the soldiers for being intoxicated. When the production moved to Italy later that spring to complete the production, Holden's drinking became more serious. At one point, he got so drunk that he became irate during a scene and

turned a machine gun he was carrying on a crowd of bystanders and fired. Fortunately, the gun was loaded with blanks, not live ammunition (Thomas, 161; Capua, 132).

There was one other dilemma for the filmmakers, albeit a minor one, that surfaced during the Utah shoot. For a sequence in which Frederick's soldiers are taught to ski, some students from the University of Utah showed up and sneaked themselves into the picture. An article that appeared in the *Deseret News* explains: "Pam Richards and Kim Powley, both co-eds at the University of Utah, heard that David L. Wolper's 'The Devil's Brigade' was filming ski training scenes...near Salt Lake City. They decided to become extras in the picture....There was just one hitch: There were no females in the scenes, just stars William Holden, Cliff Robertson and Vince Edwards, plus the busy extras, all members of the National Ski Patrol. It was this last that made it easy—the girls simply climbed into the baggy white parkas and ski pants worn by the Ski Patrol, acted as much like males as possible, and weren't discovered till [sic] the parkas came off at lunch. Had they been trying to crash the movies, Director McLaglen asked. 'Gosh, no!' Pam said. 'We're not interested in Hollywood. We just wanted the \$15 a day you pay—and a chance to meet all those boys'" ("Money Lured Them to the Screen").

The Devil's Brigade received mixed reviews and stumbled at the box office upon its release in May 1968 ("Cinema: The Devil's Brigade"). [The film had its premiere screening in Salt Lake City at the Lyric Theater near Temple Square, ("'Brigade' Has Humor, Action").] Many critics faulted the picture for bearing too close a resemblance to Robert Aldrich's *The Dirty Dozen* (1967), which also focuses on misfit soldiers who undergo rigorous training before they head out for battle. The review in *Time*, for instance, noted, "Last year it was *The Dirty Dozen*. This year it is the filthy 1,500, a mixed bag of World War II regimental rejects who hate the brass en masse. As in *Dozen*, they are given a last chance to shape up or ship out." Wolper, however, claims that he and McLaglen had no intention of mimicking the earlier film; he argued that the parallels between the two pictures were coincidental and that rather than being helped by its likeness to *The Dirty Dozen*, *The Devil's Brigade* suffered: "Unfortunately, [our picture] came out just a few months after the release of *The Dirty Dozen*, which was the same kind of story. It was a big hit and it killed us. We got lost in the wind" (Wolper, 164).

The Devil's Brigade may have had a poor run at the box office, but in the decades since its release, it has nevertheless found an audience of admirers, thanks in part to frequent broadcasts on cable television. Notably, director Quentin Tarantino has cited the feature as an

influence on his Oscar-winning blockbuster *Inglourious Basterds*. (“Pulp and Circumstance”). The outdoor sequences in Tarantino’s lauded film, however, were shot in Germany and France, and while the landscapes in this picture are often scenic, they lack the grandeur that characterizes the jagged peaks and sprawling valleys that surface in *The Devil’s Brigade* (“Bunch of Guys on a Mission Movie”). Might *Inglourious Basterds* have been a stronger film if Tarantino had shot it in Utah? We can only guess.

Works Cited

Capua, Michelangelo. *William Holden: A Biography*. Jefferson, NC: McFarland, 2010.

Greenberg, Abe. “Now Meet Andy McLaglen.” *Citizen News*. 24 Feb. 1968.

Hohennadel, Kristin. “Bunch of Guys on a Mission Movie.” *New York Times* 6 May 2009: AR15

McLaglen, Andrew. Personal interview. 10 Mar. 2010.

Pearson, Howard. “‘Brigade’ Has Humor, Action.” *Deseret News* [Salt Lake City] 20 May 1968: 2B.

Staff. “Andrew McLaglen Keeps Control at all Times.” *Ottawa Citizen* [Can.] 3 June 1967: 20.

Staff. “Cinema: The Devil’s Brigade.” *Time* 31 May 1968.

Staff. “Money Lured Them to Camera.” *Deseret News* [Salt Lake City] 26 Dec. 1967: 8A.

The Devil’s Brigade. Dir. Andrew V. McLaglen. Perfs. William Holden, Vince Edwards, Cliff Robertson. 1967. DVD. United Artists, 2002.

Tarantino, Quentin. “Pulp and Circumstance: Tarantino Rewrites History.” *Fresh Air*. National Public Radio. KNPR, Las Vegas. 27 Aug. 2010.

Thomas, Bob. *Golden Boy: The Untold Story of William Holden*. New York, St. Martin's, 1983.

Ure, John. "Cops Break Out Heavy-Duty Machines to Retake Ravaged Corner Canyon." *Salt Lake Tribune* 2 May 1994: D1.

Wolper, David L., with David Fisher. *Producer: A Memoir*. New York: Scribner, 2003.

InterPlay: Performing on a High-Tech Wire (Collaborative, Real-Time, Distributed, Surrealistic Cinema)

Elizabeth Ann Miklavcic and Jimmy Miklavcic

*Another Language Performing Arts Company
University of Utah Center for High Performance Computing*

Abstract

This paper will describe the InterPlay form and discuss its process and structure through the investigation of eight InterPlay performances. It will analyze some of the issues that have been encountered and surmounted and those that require continued examination. It will also discuss subjects such as distributed collaboration, communications, production elements, real and virtual venues, and the layered development of works within this innovative art form.

Introduction

InterPlay, a Telematic Performance Form

Telematic performance maintains connections to early Fluxus events of the 1960s and 1970s by artists such as John Cage and Alan Kaprow (Bukoff 2006). In the 1980s, artists such as Roy Ascott began integrating computer, networking, communications technology, and infrastructure into what is now defined as telematic art, with works like *La Plissure du Texte* (1983) (Shanken 2003). In the new millennium, artists and technologists in academic institutions have taken advantage of the latest network and computer advances to investigate the creative possibilities in merging dance, music, visual arts, and theater with the global network infrastructure to create innovative collaborative works. Another Language Performing Arts Company (ALPAC), in partnership with the University of Utah (UU) and the Center for High Performance Computing (CHPC), is among the leaders in telematic performance.

InterPlay is a multifaceted, real-time, collaborative digital performance event that occurs simultaneously at multiple sites throughout the world. Artists and technologists from several academic institutions synchronously perform and collaborate in real-time, streaming digital cinema and audio while using media and technologies of various forms, such as computer animation, remote Musical Instrument Digital Interface (MIDI) control, motion capture, interactive distributed virtual reality, and Access Grid[®].

Electro-acoustic musicians, dancers, actors, digital graphic artists, virtual reality designers, video artists, motion control engineers, and a variety of creative technologists come together, integrating their ideas into this large-scale, distributed performance. Each performance site generates two or more video and audio streams, using the Access Grid video communications technology, and transmits them onto Internet2. These video streams are collected, processed, combined into the digital mix at the host site, and then transmitted back onto the network. This multimedia content is integrated into each site's local performance, creating a live, distributed, cinematic performance event.

The first *InterPlay* performance premiered in March 2003 with *InterPlay: Intransitive Senses*. Since then, there have been seven additional *InterPlay* productions.

The Process and Structure

The collaborative creative process and the technological structure of an *InterPlay* performance is a complex undertaking that involves distributed creative collaboration, digital communication, technological

and network infrastructure support, production elements, rehearsal, and performance. Each of these elements possesses several challenges that require close attention by the directors of the host site. The host site is responsible for the execution of the entire project. This also includes scheduling weekly distributed video conference meetings, testing new technologies and integrating them into the project, network troubleshooting, systems support, communication, overall publicity, documentation, rehearsals, direction, and post production. The University of Utah CHPC was the host site for the *InterPlay* performance series, codirected by Elizabeth and Jimmy Miklavcic from 2003 through 2010.

Distributed Collaboration

The *InterPlay* begins with an artistic concept as a foundation on which all participants can build. Artists and technologists at each site interpret the artistic concept and create a performance based on their particular discipline and technological infrastructure. The host site guides, directs, and assists the participants in the development of each site's creative contribution to integrate that work into the entire artistic event.

The coordinators of the participating sites are responsible for all local creative and technological contributions to the project. They work closely with their regional artists and technologists, schedule local meetings and testing sessions, monitor creative and technical progress, generate local publicity, and are responsible for other activities at their site.

Communications

The *InterPlay* form is built on an infrastructure of internet protocol (IP)-based telecommunications. ALPAC and all collaborating sites use the Access Grid technology for telecommunications and performance activities. The level of communication necessary to create a coordinated piece over long distances is extensive. Constant communication with all participating sites is crucial to the success of the production; this process consists of videoconference meetings, telephone calls, emails, wikis, and web blogs. To coordinate and develop a project, no single form of communication is sufficient in this collaborative process. For example, to create a fully integrated piece such as *InterPlay: Nel Tempo di Sogno* (2007), three or four meetings a week with individuals and groups, telephone calls, web blogs, as well as more than 500 e-mail messages were required to coalesce the six participating sites.

Technology and Network Infrastructure

Jimmy Miklavcic, with the assistance of Sam Listen at CHPC, adapted the Access Grid technology for use as a performance system, modeling the venue server, *artgridvs.chpc.utah.edu*, after a theater space. The virtual Lobby has access to a Black Box, a Café, a Theatre, and two Studios. Through the Theatre, there is access to the Back Stage, Green Rooms, and other virtual areas. The goal is to one day map the virtual theatre to physical theatrical spaces, connecting components of several theaters distributed globally.

The Access Grid software is scalable and can operate on a single laptop or expand to a larger Enhanced Performance Grid. The Enhanced Performance Grid is an environment of as many as 20 various systems that, together, supports the *InterPlay* event. It consists of streaming, broadcast, display, video-capture, recording and venue servers, an audio control system, streaming collectors, video effects processors, and text-chat systems. The heterogeneous computational environment creates a highly distributed event, taking into account all the participating sites.

Production Elements

The technological tools used during the *InterPlay* performance are crucial. Professional video cameras, high-fidelity microphones, computers, lighting design, and a detailed layout of the performance space are used to provide high-quality content. A team of creative technicians at each site is necessary: Minimally, this includes a cinematic display operator, a lighting technician, several camera operators, an audio engineer, and a performance manager. Communication with the site's network personnel is essential, and some understanding of the backbone network topology is helpful.

During performances, the camera is a portal into the artist's world. Awareness of the quality of the streamed video and its framing is imperative. Providing useful content is achieved by having knowledge of camera technique and effective lighting. Regardless of the quality of each site's live performance, if it is not visually comprehensible through the camera, then the work is lost within the scope of the *InterPlay*. Providing high-quality visual imagery is important even if the main component supplied by the participating site is audio. Some considerations include close, medium, or wide shots to produce compelling imagery enhancing the overall *InterPlay* production.

Lighting and audio design is critical for an interesting and technically executed performance. Each site's local performance needs a

lighting plan that encompasses both a well-lit theatrical design for their live audience and a cinematic lighting design for the camera to benefit the network audience.

Providing high-fidelity audio is a primary component and the most pronounced challenge of working within this form. There are many components in the audio design that can malfunction, and troubleshooting such problems is complex. The audio equipment required includes an echo canceling system, audio transmission software, a sound card's software mixing system, microphones, audio mixer, and local/remote sound systems.

Performance Venues

Performance venues exist in two forms, the physical and the virtual. The physical performance venue is the space that houses each site's live performance and its audience. The virtual performance venue is the place where the Internet viewer can experience the performance.

There are very few traditional performance venues that have the cyber infrastructure required to support an *InterPlay* event. In Utah, ALPAC uses a lecture hall in the Intermountain Networking and Scientific Computation Center (INSCC) at the UU. Other examples include the Electronic Visualization Lab at the University of Illinois, Chicago, and the Discovery Lab in the Arctic Region Supercomputing Center (ARSC) at the University of Alaska, Fairbanks (UAF).

The Access Grid technology provides the best virtual view of the *InterPlay* event, for the Internet audience, with its multiple video and audio streams. The viewer is able to see all simultaneous content, including the digital mix. A live QuickTime stream of the digital mix is also available on ALPAC's web site, www.anotherlanguage.org/interplay.

During the 2007 *InterPlay* performance, an uncompressed 30 megabit-per-second digital video stream using the Digital Video Transport Systems (DVTS) was provided. This video stream was only available to users that connected through professional or educational facilities with the appropriate bandwidth and infrastructure. As of 2009, the performances have been streamed into Second Life at the UU Marriott Library Island, and in 2010, the UU Information Technology Department established a live Flash broadcast.

Rehearsals

InterPlay rehearsals include individual site testing and experimentation followed by a progression into multi-site rehearsals. Scheduling involves the coordination of local and remote teams. This requires awareness of the time zone differences and the schedules of each site's participants. Differences in time zones can result in confusion, so it is helpful if the schedule specifies the appropriate times for each zone.

The rehearsals function as test sessions and technical trials, where performers interact with the technology. These preparations are critical in determining what technologies can be incorporated into the project. This is the time for troubleshooting multicast network issues; testing and integrating software and hardware development, utilizing new audio–video streaming systems, adjusting human–technology interfaces, researching other emerging technologies, and, most importantly, integrating the artistic contributions from each site into the overall *InterPlay* event.

InterPlay *Performances*

ALPAC, in partnership with the UU CHPC, hosted, created, and produced eight *InterPlay* projects in collaboration with 16 institutions and research labs across North America, Canada, and the United Kingdom from 2003 to 2010. The following project descriptions will highlight many of the structural concepts of the *InterPlay* process. More information and videos of these performances can be seen at www.anotherlanguage.org/interplay.

InterPlay: Intransitive Senses (2003)

InterPlay: Intransitive Senses, directed by Jimmy Miklavcic, premiered on April 19, 2003, was an investigation that concurrently streamed four simultaneous performances and processed the video streams as *found objects*. The overall goal was to weave a distributed tapestry of kinetic imagery. It incorporated four performances from four locations on the first floor of the INSCC building. This prototype project provided an opportunity to understand the constructs needed to expand the collaboration process into a larger, more complex distributed event. *Intransitive Senses* included four simultaneous performances by five artists, Elizabeth and Hanelle Miklavcic (performance artists), Flavia Cervino-Wood (violinist and performance artist), Harold

Carr (bassist and poet), and Alex Caldiero (poet and sonosopher). A camera operator was assigned to each performance location in the building, and the corresponding video feeds were mixed, processed, and transmitted onto the Internet.

InterPlay: Intransitive Senses was performed a second time for the *Symposium in Science and Literature* at the UU on October 10, 2003. Artists for this performance were Elizabeth and Hanelle Miklavcic, Alex Caldiero, Sam Liston (guitarist), and Kate Macleod (violinist). In this performance, Elizabeth and Hanelle's performance was placed on the third floor of the INSCC building to simulate a remote site and to test the reliability of video, audio, and communications over a longer distance.

Embedded Performance (Utah) - Tea Party

Elizabeth Miklavcic investigated the development of embedded performance works within the *InterPlay* form. In the first four *InterPlays*, Elizabeth conceived the embedded performance as an anchor event for the local Utah audience and as a foundation to the shape of the overall *InterPlay* event. In *InterPlay: Intransitive Senses*, she created *Tea Party*.

As one of the UU's four simultaneous performances of *InterPlay: Intransitive Senses*, it was a performance/installation that depicted a cross-generational place of play and sharing within the simple constructs of a tea party. It was a very gentle piece that focused on acceptance, by allowing the tea party guests (Elizabeth and Hanelle Miklavcic) to play through the fantasy of color and design.

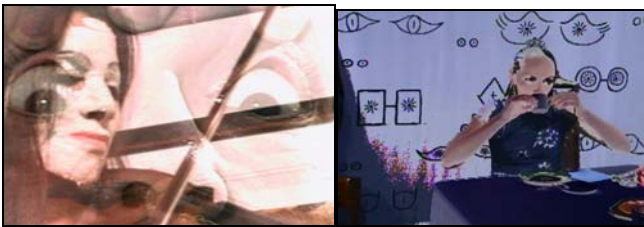

(Left) Video still from *InterPlay: Intransitive Senses*. Pictured: Flavia Cervino-Wood, Alex Caldiero. (Right) Hanelle Miklavcic in *Tea Party*

Magical bags were filled with a variety of items and hung from the ceiling. The bags depicted the magic of discovery; once the contents were exposed, they were then explored and incorporated into the ever-changing environment of the tea party installation. The sequence of actions by the partygoers was predetermined, but the conversation and some of the events were left open to improvisation. By the time the tea party came to a conclusion, the whole environment had been transformed by the interaction of the two people spending time together.

InterPlay: Hallucinations (2004)

InterPlay: Hallucinations debuted on April 23–25, 2004. This performance, for the first time, incorporated remote sites: the UAF and the ARSC, with artists Miho Aoki (computer graphics), Scott Deal (percussion), and Paul Mercer (technologist); the University of Maryland (UMD), with artists Nadja Masura (video) and Brian Buck (dance); and ALPAC at the UU.



(Left) Video still from *InterPlay: Hallucinations*. Pictured Mary Larimer, Brian Buck. (Right) Aaron Henry, Tony Larimer and Beth Miklavcic in *The Surface of Things*.

Hallucinations explored various types of social, commercial, and political hallucinations. Each site interpreted the concept through several different performance and media forms. Artists from UMD investigated commercial and political brainwashing through dance and video, UAF investigated the delusion of communication through music and computer animation, and UU dealt with social hallucinations through computer animation and the theatrical performance of Elizabeth Miklavcic's *The Surface of Things*.

Embedded Performance (Utah) - The Surface of Things

The Surface of Things focused on stereotypes of first impressions and assumptions that are in direct conflict with the real personae. The work consisted of a younger man, Opponent A (Aaron Henry), and an older woman, Opponent B (Elizabeth Miklavcic), and a mediating Judge (Tony Larimer). Opponents A and B vocalized assumptions based on outward appearances. They directed video cameras at each other and used the projected video images as ammunition for their misinformed statements. Images were projected on the scrim and hanging sheets of frosted Plexiglas. Two full-length mirrors hung on the walls and a hand-held mirror allowed the opponents to examine their own *surface*. The Judge, as an outside observer, recognized the encounter and became the instrument that empowered the two opponents to drop their assumptions and see clearly for the first time.

Flash animations (created by Elizabeth) played during pauses in the exchange. The animations served as an abstract apparition of the inner voice. The *Surface* play served as a statement examining the human tendency to make assumptions. As the play resolved and the opponents became friends, two new opponents appeared with a new judge and the assumption dance began again.

InterPlay: Loose Minds in a Box (2005)

InterPlay: Loose Minds in a Box was performed March 31–April 2, 2005. Participating institutions included UAF and ARSC, UMD, CHPC at the UU, ALPAC, University of Illinois, Chicago (UIC), the Envision Center for Data Perceptualization (ECDP), University of Montana (UMT), and Purdue University (PU).

This *InterPlay* explored aspects of multiple personalities or schizophrenia. Approached abstractly, the concept allowed for a broad interpretation of the psychological theme. The performance structure was divided into six scenes that featured different artists and technologists individually or in groups of two or more. Miho Aoki (UAF) developed a plan to represent each scene by color. From this, a dramaturgy was developed to organize the progression through the scenes. Each scene contained different background designs and geometrical arrangements of the live video windows. These were placed in real-time by the display operator to evoke a dynamic kinetic progression of the cinematic display.

Timothy J. Rogers (PU), a motion capture engineer, worked with dancer Joe Hayes (PU) and choreographer Carol Cunningham (PU) to map and translate the dancer's movements into MIDI data that was

transmitted to the other sites, controlling audio and video processing. Dioselin Gonzalez (PU), a virtual environment engineer developed a software module for the Access Grid called AG Juggler. This program allowed audience members at all participating sites to manipulate avatars in Purdue's visualization lab. Miho Aoki and David Sigman (PU) created the three-dimensional graphics for the virtual environment.



(Left) *InterPlay: Loose Minds in a Box*. Mixed Stream; Dancer Joe Hayes inside the Box. (Right) *InterPlay: Loose Minds in a Box*. Pictured: Elizabeth Miklavcic (Utah) and Joe Hayes (Purdue) in the virtual environment

The final *InterPlay: LMIB* scene was an excellent example of site integration. It featured Charles Nichol's (UMT) recordings of *The Blue Box* haiku, written by Nadja Masura (UMD). He created an interactive composition that was manipulated by dancer Joe Hayes. Recorded readings of the haiku by Dwight McKay (PU), Tina Shah (UIC), Nadja Masura (UMD), and Jimmy and Elizabeth Miklavcic (UU) were processed through MAX/MSP and controlled by Hayes' movements at PU. Timothy Rogers captured the X and Y coordinates of Hayes' movements and converted them to MIDI control parameters. These data were sent over the Internet to UMT, using a transport program written by Rob King and facilitated by Many Ayromlou from Ryerson University in Toronto, Ontario, Canada.

InterPlay: Loose Minds in a Box was performed again for SIGGRAPH 2005 at the Los Angeles Convention Center on August 3 and 4 and for Supercomputing Global 2005 in Seattle, Washington, on November 17.

Embedded Performance (Utah) - Dressers

Dressers was an endeavor to coordinate a specific idea among sites. Remote performers from different locations worked with the concept of the restrictions or freedoms of external *costumes*. The structure for dressing began with sedate or normal clothing and worked toward a more outlandish or fantastic presentation.

The premise of *Dressers* was based on readily observable external changes in appearance as indicators into affiliations such as class, status, wealth, intelligence, mental health, etc. The exploration involved a philosophical premise of personalities in constant fluid motion like a lava lamp. The analogy of each heat-activated floating bubble inside the lamp represented a personality skill set revealed by external dress, which at times morphed, split, and combined according to the events of any given moment within the performance. *Dressers* was designed to show the evolution of personality through a manifestation of matching the external with the internal, through the process of dressing in different outfits and exploring physical actions influenced by these outfits.

In Utah, Elizabeth explored a variety of characters during the six *InterPlay* scenes. In Scene 1, *The Void in the Corner*, she became “Church Lady” sitting in a pew of imagination listening to a sermon and surveying the congregation’s myriad of fashion statements. Scene 2, *The Imprisonment of Thought*, introduced “Red Bandit” and “Dragon Lady.” The red satin costume was a visual and textural experience that affected movement and attitude.



(Left) Madeline Unprocessed Image. (Right) Madeline Mixed Image

In Scene 3, *The Air Inside our Head*, “Madeline” donned a 1970s polyester suit jacket, sky-blue Lycra modern dance skirt, thick blue mittens, a blue hat, and a wool scarf that tied the hat down as if to keep a chilly wind from blowing it off. Scene 4, *One is None*, focused on imprisonment and deformation, where the ceiling and front cameras were mixed together creating a perception that “Masked Witch” was

falling through the floor. In Scene 5a, *How Many Are We?*, and 5b, *Let Loose the Mind*, “Party Crasher” used layers of unique color, outlandish sparkle, and freedom from restraints for the purpose of joyful expression, symbolizing the conscious choice to free the mind and reveal the concealment of different personalities.



(Left) Crone unprocessed image. (Right) Crone mixed image.

In Scene 6, *The Blue Box*, Elizabeth portrayed “Old Crone” with a maroon velveteen cape and held a carved wooden box. Ending the performance as an aged, mysterious crone depicted a journey, a lifetime in miniature that flashed inside a little world, inside a magic box.

InterPlay: Dancing on the Banks of Packet Creek (2006)

The March 31–April 2, 2006, *InterPlay: Dancing on the Banks of Packet Creek* concept addressed the rising trend of tenuous devotion towards the inundating wave of digital information and dependence on non-experiential knowledge. *Packet Creek* depicted the Internet with its flow of disassembled pieces of data that course throughout the world like schools of spawning salmon. *Dancing on the Banks* represented the exposed ritualistic gyrations of searching, acquiring, disseminating, creating, and believing in this electronic epistemological knowledge. There were five participating sites; UAF/ARSC; Boston University (BU); UMD; PU/ECDP; and UU/CHPC and ALPAC.

The performance began with a video of a simulated Linux system booting up and graphics from UAF. The text of the Linux boot sequence was replaced with a poem by Elizabeth Miklavcic and was arranged to invoke the sense of a beginning, an awakening through a visual introduction symbolizing the ubiquitous transmission of data.

Through 10 scenes, the artists, musicians, and performers forged a slow Bolero style build that came to a complete stop when the *system* crashed. Sam Liston (UU) added a three-dimensional element to the cinematic display. The operating system of the center display provided a desktop feature that allowed the operator to map video windows onto

the outside or inside surfaces of a cube. The video windows would either slide across the surface to remain in the front while the cube was rotated or moved with the surface, revealing new video window configurations with the rotation of the cube. The arrangement of the windows on the scrim defined the visual and kinetic spirit of the overall piece. Each scene was designed to evoke a different quality, and the display structure followed a Bolero dynamic, of tension and energy, which built the layered, distributed performance events until, at the climax, all of it ended abruptly. Then the poetic boot sequence engaged once more, representing the never-ending reoccurrence of the process.

The digital mix was placed in the center of the display. It tied the various offerings together by combining different moments from each of the sites. At various moments in the piece, video from all five sites intersected in the digital mix on the cinematic display.

Embedded Performance (Utah) - Mind Waves

Elizabeth created a piece about personal and universal explorations of visual spirituality. First, she broke down the words of the *InterPlay* title: *dancing*—movement as expressive spiritual life force; *banks*—the representation of an edge, the place where elements meet and transitions exist, places of magic; *packet*—packets as enclosed matter, or bounded information; *creek*—water, flow, force, life, sensation, reflection, an element that must be respected.

Inspiration came from the Great Salt Lake and an earthwork created by Robert Smithson in 1970, located on the northeast side of the lake. These influences were brought indoors through the building of a Zen garden and with images of the Salt Lake projected using a visualization cluster.



(Left) The southwest shore of the Great Salt Lake, Utah. (Right) The Spiral Jetty at Rozel Point, Great Salt Lake, created by Robert Smithson in 1970

A dynamic component of *Mind Waves* was the kinetic building of a string web that symbolized the formation of the World Wide Web and the entanglement of our complicated lives. Utah performer, Kate Bradford (eight years old) strung the room while Elizabeth Miklavcic constructed the Zen Garden. At BU, Robert Putnam (Access Grid Node Operator), Junko Simons (Cellist) and Jacqueline Combs (Performer), incorporated the web idea into their performance creating a visual connection between Utah and Boston.

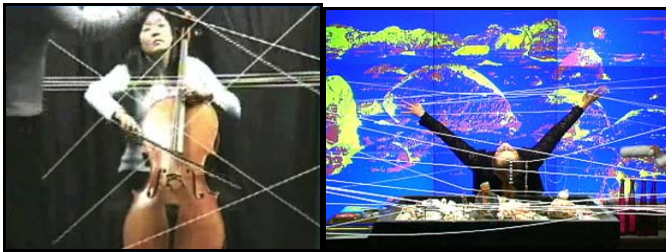

(Left) Junko Simons performing in Boston. (Right) Elizabeth Miklavcic performing in Utah

This visual effect connected both sites literally and figuratively. It was as if the strings extended across the country. The harmonious musical and visual connections between the textures of Junko's cello and the quiet approach of creating the Zen Garden tied the sites together, creating a quartet between the two sites. In *Mind Waves*, the action of filling the room with string was a symbolic representation of the *InterPlay* concept as the performers became more and more entangled in their self-created web.

InterPlay: Nel Tempo di Sogno (2007)

InterPlay: Nel Tempo di Sogno (In the Dream Time) was performed on March 30–April 1, 2007. Co-directed by Elizabeth and Jimmy Miklavcic, *InterPlay: Nel Tempo di Sogno* was a work of unprecedented integration among sites. It incorporated 32 artists and technologists and six institutions, UU/CHPC and ALPAC, UAF/ARSC, BU, University of Illinois at Urbana-Champaign, UMD, and PU.



(Left) *InterPlay: Nel Tempo di Sogno*. Pictured: Travis Eberhard and Utah Time Line. On Screen: Peter Rogers. Photograph: Rusty Kirkpatrick. (Right) *InterPlay: Nel Tempo di Sogno*. Chun-Chen Chang and Travis Eberhard in Scene 12

Elizabeth crafted artistic contributions into an integrated statement involving all contributors rather than the framework of autonomous embedded performance works. Elizabeth Miklavcic coordinated nine actors from three distributed sites (Utah, Alaska, and Maryland) into a cohesive expression examining temporal experiences. A widow from Victorian England mourned the passing of a loved one, a French aristocrat told her horrific experiences living through the French Revolution, a mid-century Cardinal struggled to tend to his flock of believers, and a talking televangelical head spouted rhetorical half-truths about the morality of time. Those and others, intersected through different moments in time, interacted and communicated with each other as they examined how their lives had slipped through time.

The multi-framed cinematic display incorporated background flash animations by Miho Aoki that ran behind the various video window arrangements. More than eight video streams of performers, musicians, and computer animations were distributed in different groupings across the display.

InterPlay: Carnivale (2008)

InterPlay: Carnivale was performed March 28–30, 2008, and co-directed by Jimmy and Elizabeth Miklavcic, and written by Elizabeth Miklavcic. This work was an examination of the mystery of the performing soul through an amalgamation of a variety of celebratory performance forms such as circus, Mardi Gras, carnival, amusement park, fair, and arcade. This live, distributed, real-time, surrealist, cinematic performance was crafted as if the viewer entered a memory of by-gone circuses, carnivals, parks, and fairs. The performance began as if frozen in time, the carnival awakened and the parade began.

Carnivale incorporated 33 artists and technologists and four institutions, UU/CHPC and ALPAC, University of Illinois at Urbana-Champaign Technology, Research, Education and Commercialization Center (TRECC), Rochester Institute of Technology (RIT) in New York, and Cardiff University Welsh e-Science Center, UK.



Travis Eberhard in Scene 3 of *InterPlay: Carnivale*

Original music compositions were created, performed, and streamed live by Joe Reitzer from TRECC. The work by Joe Geigel and Marla Schweppe at RIT included compositing three-dimensional graphic characters from their three-dimensional virtual puppet control system with live performers in Utah. Mike Daley at Cardiff University developed a Java-based video display interface for the Access Grid system called AG Carousel. The animation of the cinematic display has been a long-term goal in this research, and this was a step toward seeing the automated movement of the video windows. Unfortunately, the upgrade from the h.261 video codec to h.264 video streaming six weeks before the performance created an incompatibility with Mike Daley's Java video display interface.

InterPlay: AnARTomy (2009)

InterPlay: AnARTomy was performed March 27–29 and April 3–5, 2009. The concept of this project centered on the human body as a complex system of thought and action where the simplest impulse generates the most amazing human motion. The subject of *AnARTomy* was an exploration into this very personal receptacle as a connector through which humans operate, activate, and live.

AnARTomy incorporated 29 artists and technologists from seven institutions, UU/CHPC and ALPAC, UAF and the ARSC; Brigham Young University in Provo, Utah; Indiana University–Purdue University Indianapolis (IUPUI) and the Donald Tavel Arts and Technology Center; Long Island University in Brooklyn, New York; Cardiff Uni-

versity's Welsh e-Science Center, Wales, UK; and the Human Interface Technology (HIT) Lab at the University of Canterbury, New Zealand.

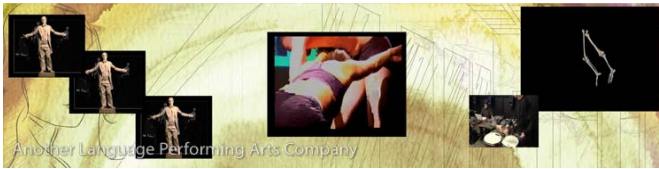

Scene 3 of *InterPlay: AnARTomy*. Pictured: Ben Spruce, Theresa Kulikowski, Patrick Barnes, and Big Robot

Two dancers in Utah, Theresa Kulikowski and Patrick Barnes, performed as moving sculptures, while simultaneously, Ben Spruce, a mime in Cardiff, Wales, responded to their movements. Artists sketched the dancers, and three-dimensional skeleton animations were sent live in response to the dancers' movements. Elizabeth Miklavcic created the structure of this work; she wrote and performed poetry that textured the tone of the three scenes, *Female Form*, *Male Form*, and *Joining Forms*. The digital mix, manipulated in real-time by Jimmy Miklavcic, tied the converging videos into an added dimension, combining artistic relationships existing in the virtual space.

The upgrade to high-definition (HD) recording and streaming created a series of problems, not the least of which was getting HD to run within the Access Grid toolkit. Nathan Gardiner and ChangHyeok Bae from the HIT Lab worked on the code to incorporate HD video streaming for *InterPlay: AnARTomy*. There were seven HD video streams in this production, and there were times when the display system had difficulty decoding the amount of HD video data that it was receiving. The HD video streams would digitally "break up," with artifacts from previous frames remaining on the screen and mixing in with the current frame. In light of the difficulties in the display system, the amount of HD video data being transmitted among the sites had very little impact on the network infrastructure. The live broadcast was available at www.anotherlanguage.org and was streamed for the first time in Second Life at the UU Marriott Library Island.

InterPlay: Event Horizon (2010)

InterPlay: Event Horizon was performed March 26–28 and April 2–3, 2010, at the UU INSCC. The concept of *Event Horizon* was based

on the exploration of the unknown future. The participating artists explored their interpretation about the discovery of what is just beyond sight or knowledge.

Co-directed by Elizabeth and Jimmy Miklavcic, participants included Carrie Baker (UAF) who performed original poetry and movement at the ARSC Discovery Lab; Miho Aoki, living in Tokyo, Japan, at the time, who contributed processed digital video; Diana Hsu, musician and actress, who was filmed in Los Angeles performing original flute compositions, Lexie Levitt, who created four original music compositions and performed live in Utah, and Elizabeth Miklavcic, who performed interpretive movements live in the Visualization Lab at the UU. Additional artistic elements included digital video, digital photography, and the animated background.

The display problems experienced in the *InterPlay: AnARTomy* project persisted, and the animation of the cinematic display continued to be an unsolved research aspect.



InterPlay: Event Horizon. Pictured: Lexie Levitt, Carrie Baker and Elizabeth Miklavcic

The prevailing artistic question in the midst of this development process for the *InterPlay* performances remains: How does one approach or attempt to work within an emerging medium, where constant upgrades change the landscape of creation?

The open-source nature of the Access Grid Toolkit lends itself to constant development. Additional components are developed and integrated by various developers. These components are completed but are hardly ever maintained on an ongoing basis. For example, software

packages such as Access Grid Video Conference Recorder (AGVCR) were developed at Indiana University. The developer of this event recording system has since moved, and there is no attempt to keep this package up to date with changing video formats.

Time-intensive software development is necessary to keep the many coexisting programs that make up the Access Grid Toolkit functioning. Nonetheless, the Access Grid is extremely flexible and there are very few videoconference software packages that can allow unlimited participation (the limitation only exists within the hardware system's specifications). The Access Grid's viability remains with the specialized skills of the technologists and artists that work with and use this software package.

References

Bukoff, Allen 2006. The Fluxus Portal for the Internet. Fluxus.org

Shanken, Edward A. 2003. Telematic Embrace. University of California Press

Emerging Infectious Disease Chytridiomycosis and the Significance of the Absence of *Batrachochytrium dendrobatidis* on *Hyla arenicolor* in Zion National Park

Allystair D. Jones, Daniel J. Sumko, and Curt Walker
Dixie State College

Abstract

*Chytridiomycosis, an infection caused by the chytrid fungus (*Batrachochytrium dendrobatidis*), has become a global concern threatening the stability of amphibian populations and has spread rapidly across the United States since 1999. The fungus infects the skin of amphibians and may result in death. Recent numbers suggest that more than 30% of the world's amphibian populations have already been affected. We provide the first data on whether this dangerous infective agent has migrated into the populations of the canyon tree frog (*Hyla arenicolor*) in the canyon systems of Zion National Park (ZNP) in southwestern Utah from the infected population in Arizona. To test for the presence of the chytrid fungus, epidermal swabs were collected from 69 frogs, and the*

samples were tested for DNA markers associated with the chytrid fungus as well as universal fungal markers. The PCR did not show the presence of the chytrid fungus in ZNP at this time. We propose that this population be continually monitored in this area to gain insight into the spread of this disease.

Introduction

The chytrid fungus *Batrachochytrium dendrobatidis* is a serious threat to amphibians, infecting populations globally with the disease chytridiomycosis (Berger *et al.* 2004). The first identification of a specimen infected with *B. dendrobatidis* was found in South Africa in 1938 (Weldon *et al.* 2004). Upon infection, chytridiomycosis quickly kills frogs, and it has been responsible for extinctions of at least 30 populations of frogs (Kilpatrick *et al.* 2010). *B. dendrobatidis* has infected *Hyla arenicolor* (Canyon tree frog) in Arizona, and deaths have been reported (Bradley *et al.* 2002; Schlaepfer *et al.* 2007). *B. dendrobatidis* is able to move easily from host to host through water, and the initial spread of the disease is thought to be from the transportation of frogs from one location to another either through the pet trade or for zoos (Weldon *et al.* 2004)

Of the 6000+ vertebrate species, amphibians are among the most vulnerable to disease and population decline (The Global Amphibian Assessment, <http://www.iucnredlist.org/amphibian>), with 32.5% of amphibian species threatened. Ninety-two percent of the critically endangered populations are in decline due to *B. dendrobatidis* (Stuart *et al.* 2005). With the population declines associated with *B. Dendrobatidis*, it is imperative that we understand how this disease enters and spreads through populations, both in infected populations and in vulnerable populations that have yet to be infected (Kilpatrick *et al.* 2010).

B. dendrobatidis was first described in 1998 (Berger *et al.* 2005). The fungus has a simple life cycle and can be contracted by skin to skin contact or contact with infected water. *B. dendrobatidis* needs water to survive, and desiccation will kill the fungus and break the life cycle. The sporangia produced from the zoospores infect the host. Two different mechanisms result in host mortality. An enzyme that *B. dendrobatidis* secretes is absorbed by the frog through its semi-permeable skin, damaging neural cells. The second mechanism is damage to the skin that results in a disruption in cutaneous respiration or in water and electrolyte imbalance (Berger *et al.* 2005). The exact mechanism underlying these symptoms in the frog's skin is not well known at this time (Berger *et al.* 2005).

There are a few classic symptoms to identify if a frog has been infected. PCR is needed to confirm infection, but many host frogs will present with a red coloration of the underbelly, loss of coordination and directionality, and lethargy and unwillingness to flee from predators. This makes the frog vulnerable and will kill a frog that otherwise would have been able to avoid predation.

Hyla arenicolor is found in the Southwestern United States and northern parts of Mexico. It is well adapted to a desert environment and is prevalent in most waterways in this geographic region. The canyon tree frog is a member of the *Hyla* genus that is the second largest family of amphibians, with 861 species and 42 genera. They are characterized by large toe pads and intercalary phalangeal elements that make them excellent climbers (Wiens *et al.* 2005). The canyon tree frogs usually climb out of the ephemeral pools or streams where they live and sun themselves all day perched on rocks, eating insects. This behavior is thought to help control bacterial infections (Kluger 1977) as well as help rid the frogs of unwanted parasites (Cagle 1950). The broad range and ability to disperse make this hylid an ideal model to use for the study of how *B. dendrobatidis* spreads.

Many studies and extensive sampling have shown the negative effect this fungus has on infected populations. This study describes a vulnerable population that is not yet infected. Finding and describing a population of frogs that has not yet been infected but is susceptible to this disease will provide valuable information about the disease (Kilpatrick *et al.* 2010). This study investigates whether *B. dendrobatidis* has infected the canyon tree frog population in Zion National Park. Locations with heavy foot traffic, many different waterways, large frog populations, and in close proximity to infected populations make this an ideal area to sample for *B. dendrobatidis* (Skerratt *et al.* 2008). If *B. dendrobatidis* is found in Zion National Park then we will gain insight into how far the disease had traveled, assuming it comes from Arizona. If *B. dendrobatidis* is not found, then we would have an uninfected but presumably vulnerable population to study to help us understand what protects such a population, and for how long.

Methods

Field Methods

We were unable to find any published information on the presence of *B. dendrobatidis* in Zion National Park. With permits from Zion National Park, The Utah Department of Division of Wildlife Resources, and the Bureau of Land Management, we sampled the north-

western population of *H. arenicolor* to see whether the disease has spread from Arizona. We sampled 69 different frogs throughout eight different slot canyons in Zion National Park. These slot canyons were Behuinin, Subway, Taylor Creek, Sprie, Misery, Keyhole, Pine Creek, and Leap Creek. When possible, we noted GPS location and time of day. Traversing slot canyons is difficult and required climbing and rappelling expertise because of the towering canyon walls and narrow passages. To collect samples from the frogs we used pre-established swabbing protocols (Skerratt *et al.* 2008).

A new pair of vinyl gloves was worn for each capture as these gloves may kill the fungus (Mendez *et al.* 2008). The gloves were kept in a waterproof container with a shoulder strap to keep them sterile as we traversed the canyons or while we were rappelling. All other materials used to take the samples were kept in a waterproof and shatterproof container. No nets or other items were used to capture the frogs to prevent cross contamination. All captures were attempted to be done with minimal harm and stress to the animal.

Once the frog was captured, five ventral surfaces were swabbed with five strokes each. These swabs covered the stomach area, the groin, the sides, the manus, and pes. The infection intensity of *B. dendrobatidis* varies over the body surface, and these areas are the most likely to be infected (North and Alford 2008). The swab was then cut and stored in a 2-ml vial with a snap cap according to recommended procedures (CSIRO Livestock Industries, Australian Animal Health Laboratory, Greelong, Australia). The vial was stored in a waterproof, shatterproof container in a backpack and transported to a freezer within 12 hours, where it was stored at -4°C (Skerratt *et al.* 2008) until analysis.

Lab methods

To begin testing, we cut the tip of the swab off with a razor blade. The blade was sterilized between each swab with sodium hypochlorite (Cashins *et al.* 2008). We then cultured the tip in a solution containing glucose that would grow the fungus (Boyle *et al.* 2004). Swabs were cultured for two days at 25°C in sealed 50-ml test tubes. The tubes were rocked as they cultured. We cultured a yeast fungus in the same manner to use as a control to prevent false negatives.

We tested the samples with PCR using a general fungus primer. The samples that showed positive for a general fungus were then tested with the specific PCR primers for *B. dendrobatidis* following a modified version of the protocol described by Boyle *et al.* (2004). The only alteration was that we used touchdown PCR (Korbie and Mattick

2008). The primers we used were BdLa/Bd2a (Annis *et al.* 2004), which would give us a 300-base-pair sequence if a positive was found.

Results

Of the 69 samples, 18 were positive for a general fungus. None of these 18 samples tested positive for *B. dendrobatidis*.

Discussion

The absence of the chytrid fungus in our study canyons was a significant finding, suggesting that the population in these canyons is not currently infected by *B. dendrobatidis*. With further study, a timeline can be established should this population become exposed to and infected by *B. dendrobatidis*. We know that the chytrid has infected *H. arenicolor* in Arizona (Bradley *et al.* 2002) and that *B. dendrobatidis* can spread very rapidly once it infects populations (Lips *et al.* 2006). This means there is a need for monitoring this disease in Zion National Park on an annual basis. In addition, the movement patterns of this species should be monitored to let us know how the disease will spread if this population does become infected. The annual testing and movement studies will help us understand how the disease spreads or what makes populations resistant to *B. dendrobatidis*.

The absence of the infection also makes *H. arenicolor* an ideal model, as this population may show some resistance to chytridiomycosis because of their desert environment adaptations. Because these frogs produce a mucus that allows them to almost dry their skin, they may also be able minimize parasitic infections in general. This would mean that even though there have been infections in Arizona, the frog population may not decline as rapidly as other more susceptible hosts. However, even highly resistant hosts of the fungus may contain sporangia and zoospores once infected (Pounds *et al.* 2007). Resilience and low mortality rates of infected frogs may, however, cause the population in Zion National Park to become a vector for disease. Tourists entering the park and then returning to their home state might carry the fungus with them on their shoes or gear.

H. arenicolor will secrete mucus that helps prevent cutaneous water loss (Preest *et al.* 1992). This allows the frog to sun itself for most of the day and may kill any blood parasites that have attached themselves to the host (Preest *et al.* 1992). Basking raises the body temperature of this frog to 35.8°C (Wylie 1981), and high temperatures can inhibit the fungus from growing as well as kill the fungus at 37°C (Woodhams *et al.* 2003). If *H. arenicolor* is resistant to the disease and

monitoring of the disease does not continue, these frogs may act as a reservoir for the fungus to spread to other native species and further.

Chytridiomycosis dies when exposed to high temperatures (Woodhams *et al.* 2003), and it is unclear how global warming will aid or impede this disease. It has been shown that warm years are linked to outbreaks of this fungus (Pounds *et al.* 2006); however, questions have arisen as to the validity of the correlation between warmer years and outbreaks of the fungus.

Frogs are an indicator species that can be used to assess the health of an ecosystem. As such, the importance of the continued study of the canyon tree frog in Zion National Park is clear. This study sets a foundation for an opportunity to understand how this particular disease spreads. We need to continually monitor this disease and learn how these frogs move from canyon to canyon. If we lose this species in Zion National Park, we lose a charismatic species for the ecosystem of this majestic park.

References

ANNIS, S. L., DASTOOR, F. P., ZIEL, H., DASZAK, P. AND LONGCORE, J. E. 2004. A DNA-based assay identifies *Batrachochytrium dendrobatidis* in amphibians. *J. Wildlife Dis.*, 40, 420-428.

BERGER, L., HYATT, A. D., SPEARE, R. AND LONGCORE, J. E. 2005. Life cycle stages of the amphibian chytrid *Batrachochytrium dendrobatidis*. *Dis. Aquat. Organ.*, 68, 51-63.

BERGER, L., SPEARE, R., HINES, H. B., MARANTELLI, G., HYATT, A. D., MCDONALD, K. R., SKERRATT, L. F., OLSEN, V., CLARKE, J. M., GILLESPIE, G., MAHONY, M., SHEPPARD, N., WILLIAMS, C. AND TYLER, M. J. 2004. Effect of season and temperature on mortality in amphibians due to chytridiomycosis. *Aust. Vet. J.*, 82, 434-439.

BOYLE, D. G., BOYLE, D. B., OLSEN, V., MORGAN, J. A. T. AND HYATT, A. D. 2004. Rapid quantitative detection of chytridiomycosis (*Batrachochytrium dendrobatidis*) in amphibian samples using real-time Taqman PCR assay. *Dis. Aquat. Organ.*, 60, 141-148.

BRADLEY, G. A., ROSEN, P. C., SREDL, M. J., JONES, T. R. AND LONGCORE, J. E. 2002. Chytridiomycosis in native Arizona frogs. *J.*

Wildlife Dis., 38, 206-12.

CAGLE, F. R. 1950. The life history of the slider turtle, *Pseudemys scripta troostii* (Holbrook). *Ecol. Monogr.* 20, 31-54

CASHINS, S. D., SKERRATT, L. F. AND ALFORD, R. A. 2008. Sodium hypochlorite denatures the DNA of the amphibian chytrid fungus *Batrachochytrium dendrobatidis*. *Dis. Aquat. Organ.*, 80, 63-67.

KILPATRICK, A. M., BRIGGS, C. J. AND DASZAK, P. 2010. The ecology and impact of chytridiomycosis: an emerging disease of amphibians. *Trends Ecol. Evol.*, 25, 109-118.

KLUGER, M. J. 1977. Fever in the frog *Hyla cinerea*. *Thermobiology*, 2, 79-81.

KORBIE, D. J. AND MATTICK, J. S. 2008. Touchdown PCR for increased specificity and sensitivity in PCR amplification. *Nat. Protoc.*, 3, 1452-1456.

LIPS, K. R., BREM, F., BRENES, R., REEVE, J. D., ALFORD, R. A., VOYLES, J., CAREY, C., LIVO, L., PESSIER, A. P. AND COLLINS, J. P. 2006. Emerging infectious disease and the loss of biodiversity in a Neotropical amphibian community. *Proc. Natl. Acad. Sci. USA*, 103, 3165-3170.

MENDEZ, D., WEBB, R., BERGER, L. AND SPEARE, R. 2008. Survival of the amphibian chytrid fungus *Batrachochytrium dendrobatidis* on bare hands and gloves: hygiene implications for amphibian handling. *Dis. Aquat. Organ.*, 82, 97-104.

NORTH, S. AND ALFORD, R. A. 2008. Infection intensity and sampling locality affect *Batrachochytrium dendrobatidis* distribution among body regions on green-eyed tree frogs *Litoria genimaculata*. *Dis. Aquat. Organ.*, 81, 177-188.

POUNDS, J. A., BUSTAMANTE, M. R., COLOMA, L. A., CONSUEGRA, J. A., FOGDEN, M. P. L., FOSTER, P. N., LA MARCA, E., MASTERS, K. L., MERINO-VITERI, A., PUSCHENDORF, R., RON, S. R., SANCHEZ-AZOFEIFA, G. A., STILL, C. J. AND YOUNG, B. E. 2007. Ecology - Pounds *et al.* reply. *Nature*, 447, E5-E6.

PREEST, R. M. DOUGLAS, G. BRUST. WYGODA, L. M. 1992. Cutaneous water loss and the effects of temperature and hydration state on aerobic metabolism of canyon treefrogs, *Hyla arenicolor*. *Herpetologica*, 48, 210-219.

SCHLAEPFER, M. A., SREDL, M. J., ROSEN, P. C. AND RYAN, M. J. 2007. High prevalence of *Batrachochytrium dendrobatidis* in wild populations of lowland leopard frogs *Rana yavapaiensis* in Arizona. *Ecohealth*, 4, 421-427.

SKERRATT, L. F., BERGER, L., HINES, H. B., MCDONALD, K. R., MENDEZ, D. AND SPEARE, R. 2008. Survey protocol for detecting chytridiomycosis in all Australian frog populations. *Dis. Aquat. Organ.*, 80, 85-94.

STUART, S. N., CHANSON, J. S., COX, N. A., YOUNG, B. E., RODRIGUES, A. S. L., FISCHMAN, D. L. AND WALLER, R. T. 2005. Response to comment on "Status and trends of amphibian declines and extinctions worldwide". *Science*, 309, 1999.

WIENS, J. J., FETZNER JR, J. W., PARKINSON, C. L., AND REEDER, T. R. 2005. Hylid frog phylogeny and sampling strategies for speciose clades. *Syst. Biol.*, 54, 719-748

WELDON, C., DU PREEZ, L. H., HYATT, A. D., MULLER, R. AND SPEARE, R. 2004. Origin of the amphibian chytrid fungus. *Emerg. Infect. Dis.*, 10, 2100-2105.

WOODHAMS, D. C., ALFORD, R. A. AND MARANTELLI, G. 2003. Emerging disease of amphibians cured by elevated body temperature. *Dis. Aquat. Organ.*, 55, 65-67.

WYLIE, S. R. 1981. Effects of basking on the biology of the canyon treefrog, *Hyla arenicolor* Cope. Ph.D. Dissertation, Arizona State University, Tucson, Arizona

The Risk That Wasn't There: Understanding the Role of Derivatives on Reducing and Creating Risk

Leo Chan

Utah Valley University

Abstract

Traditional finance teaching on derivatives suggests that they can be used to reduce portfolio and market risk. Such outcome hinges on the assumptions that derivatives are used as risk management tools and that there is at least one true hedger in the transaction. In the absence of hedgers, however, the trading of derivatives actually creates greater risks for the market. This paper explains how derivatives can reduce overall portfolio risk when used as hedging, and how their use could create greater risk if there are only speculators trading derivatives among each other.

Introduction

Derivatives have been in the news often since the collapse of the credit market in 2008. Most of the information about derivatives presented by the media is misleading at best, if not altogether wrong. This, in part, is due to the complicated nature of derivatives. It is difficult enough for an average person to understand a simple financial asset. It is far more difficult to understand the assets in which these financial assets are based on. The other major contributing factor is the lack of clarity about the true nature of derivatives in financial education, both in academic settings and the mass media. The objective of this paper is to contribute to our understanding of the true nature of derivatives as a risk management tool, as well as potential risk-inducing financial instrument.

Derivatives have been portrayed as a risk management tool in academic research articles and finance textbooks. The central argument has been that a portfolio that includes derivatives could reduce the overall risk. Most textbooks (e.g., Hull 2008; Jordan and Miller 2009; Strong 2009) also show that trading stock options requires a lower initial capital and thus has the potential of achieving higher returns. Derivatives contracts have been used as examples of how users and producers can reduce their risk by entering into these contracts. These portrayals, however, are incomplete because they all assume the derivatives markets are used mostly by true users and hedgers. The third player in the derivatives market is the speculators. In an efficient market, the number of speculators is assumed to be small relative to true users and thus can be ignored. The markets for most derivatives are anything but efficient (Davis 2008). The explosion of new derivatives products and spikes in trading volumes for some of the existing products in recent years point to markets that are full of speculators (Gilbert 2010).

In this paper, I will present a brief analysis of how derivatives can be used as a risk management tool and the impact of speculators on the overall risk of the derivatives markets. The rest of the paper is organized as follows: In the next section, I will present a brief introduction and general argument for using derivatives to reduce risk. In the third section, I will present a more complete picture of risk when speculators dominate the various derivatives markets. Next, I will discuss more complex derivatives and how they can affect the market risk. I will conclude with a discussion of complex derivatives, such as the many credit default swaps (CDSs) American Insurance Group (AIG) entered into and the speculations in oil futures that have created a riskier mar-

ket, and how to improve education and understanding of the derivatives market.

Introduction to Derivatives

Derivatives are so named because the value of these assets derives from other assets. The underlying assets for derivatives can be tangible (commodity derivatives) or intangible (financial derivatives). There are also derivatives of derivatives (options on futures) that are very popular among traders. In recent years, exotic derivatives, such as weather derivatives and CDSs, have been engineered to meet the needs of traders and possible hedgers.

The first derivative contracts traded in the U.S. were forward contracts among producers and users of agriculture commodities, started in 1833 (Besant 1985) to deal with demand and supply imbalances that lead to large losses for producers. A forward contract is an agreement between two parties (possibly the true producer and the end user) to sell a certain amount of goods for a specific price at a future date. By agreeing to this arrangement, both parties avoid any possible price fluctuations between the actual transaction took place. To see how this transaction reduces the risk for both sides, let's consider the following example: A cattle farmer has 1000 heads of cattle that will be ready for the market in 6 months. Assuming that each cattle can produce 200 pounds of meat, the cattle farmer has 200,000 pounds of meat he must sell in 6 months. Assume that the current wholesale price for meat is \$2 a pound. The future price is unknown. There is a possibility that the wholesale price could go up to \$2.30 or drop to \$1.90 a pound, with 50–50 possibility for each price. The expected price is \$2.10. If the cattle farmer waits until the end of the sixth month, he is subject to two possible incomes: \$460,000 if the price is at \$2.30 a pound, or \$380,000 if the price is \$1.90 a pound. The expected income is \$420,000 and a standard deviation of \$40,000. The same dilemma is faced by the end user of meat. Both parties can enter into a forward contract that will require the producer to deliver 200,000 lbs of meat at \$2.10 a pound in 6 months to the end user. Under such agreement, the producer is certain to get the \$420,000 and the cost to the end user is also \$420,000. There is no price risk to either party.

Since the start of the first forward contract, the market has seen a significant growth, both in number of participants and variation of contracts. An organization exchange was formed to standardize these contracts and facilitate trading of these contracts. The standardized contracts being traded in the exchange are called futures contracts. Within the exchange, there is a third player involves in the trading of

these contracts: speculators. Harris (2003) and Bekaert et al. (1995) argue that speculators are necessary for an efficient market because they will drive down the bid–ask spread. Market efficiency theory also argues that speculators are relatively few in number and the volume of the contracts in which they buy and sell are relatively small so they cannot affect the price in a significant way.

In theory, it is free to enter into futures position, although the exchange requires both parties to put up an initial deposit called initial margin (less than 20% of the contract value for most contracts) when they enter into the position. The margin requirement reduces the possibility that a speculator with a small amount of funds will be able to have too big of an influence on the market price, as well as a guarantee that both parties could fulfill their obligation to each other. However, there was no formal limit on the position value of a particular investor prior to the 2010 financial reform. Therefore, an investment company that has large amount of funds to speculate in the futures market could have significant impact on the trading activities, and thus price volatility.

The second type of simple derivative contracts is call and put options. An option gives the holder of the option to buy (call) or sell (put) an asset at a specific price at specific date. There are two types of options in terms of the ability to exercise. The American option allows early exercise (single stock options), while the European option can only be exercised at the date of expiration (index options). For example, a June \$30 Microsoft (MSFT) call gives the holder of the call the right to buy MSFT for \$30 until the third Friday of June. If the holder of the call does not exercise the option until the end of the third Friday, the contract will be exercised if the option is in the money (when strike price is below the current market price). For example, if the MSFT price in the third Friday of June is \$33, the option is worth \$3. If the price of MSFT is below \$30, the value of the option is \$0.

Most finance textbooks teach the impact of options in three different possible scenarios: a portfolio with stocks only, a portfolio with options only, or a portfolio with options equal to the number of stocks that would equal the number of shares under the stock-only portfolio and investing the rest in risk-free asset. Bodie et al. (2009) argue that a portfolio with call options and Treasury bills (T-bills) would produce the lowest level of risk because the most an investor would lose is the option premiums. This argument, however, is incomplete. If all investors are rational, they would not purchase the underlying asset and thus making the asset worthless. A stock that is worthless has no option contract, and the investors would be investing in T-bills only. A portfolio with options only is the riskiest portfolio.

There are many other possible combinations of options and the underlying asset (see Hall 2008). A portfolio with a long (short) position on the underlying asset and a put (call) option is a protective position. A protective position involves buying a put to limit the downside risk of the long position in the underlying asset, or a long position on calls to protect a short position in the underlying asset. There are other possible use of options and underlying assets combinations. For example, the long position holder of the underlying could write a call option to generate income from the option premium if the portfolio manager believes the stock price will remain within a certain range (below the exercise price). This combination limits the upside potential for the portfolio if the stock price goes above the strike price of the call on which they are written.

The Impact of Speculations on Portfolio Risk

Ross (1976) pointed out that the existence of options contract completes a market, thus improving market efficiency and reduces market risk. The Black-Scholes (1973) option pricing model uses the volatility of the underlying asset as one of the factors affecting option price. Nothing in the literature discusses the possibility of options affecting the volatility of the underlying assets. However, there is evidence that points to possible manipulation of underlying assets by large holders of options contracts to affect the spot price to gain from the sudden, large price fluctuations. Davis (2008) pointed out that an investment firm, the Vitol Group, held \$8 billion worth of crude oil in one day, more than 3 times the daily consumption in the U.S. Hoarding such a large amount of the underlying asset for crude oil future would allow the holder of oil futures contracts to drive up spot (and thus futures) price, resulting in large gain for the long position holder. This practice is commonly known as cornering the market. While it is illegal to corner the market, it is very difficult to prove any particular firm's participation in cornering the market.

There are many other ways a large position holder could manipulate the market to reap large gains. For example, a writer of call options could benefit from the calls being expired worthless. A large holder of short position in a stock with relatively small trading volume could drive the price down by shorting a relatively small amount of stocks to drive the price down, benefiting both from the expiration of the calls and the short position. Similar actions could be taken by holder of large short position in put options. Holders of a short position on puts can buy the underlying assets, thus driving up the price and profit from the put being expired worthless, and long position on stocks. These types

of manipulations will drive up the volatility of the underlying assets. It is particularly true if the underlying asset is a thinly traded asset or there are a large number of speculators in the options market.

The potential for risk reduction by using derivative contracts only applies if the derivatives are used for hedging purposes. When speculators are introduced into the mix, the risk could go up, potentially very significantly if the volume is small. Take the cattle futures market example we used in the previous section. If there is no end user in the market, the speculators who enter into the forward position with the cattle farmer would absorb the price risk. In this case, the risk has not been eliminated by the futures contracts, it has simply been transferred from one party to another party. Now, if we extend the example by assuming that both the long and short position holder are speculators, the risk is not eliminated as in the case of the true user and producer. The risk of speculators on both sides of the contracts could increase the risk of the market considerably since the initial capital requirement for derivative contracts is much smaller.

Most textbooks on investment or derivatives only discuss options as potential substitutes for the underlying asset, or protection for the value of a portfolio. All of them show all of the potential gain/loss of the option/underlying combinations. None of them show the potential for risk reduction if the underlying asset reached a certain price level in expiration. I will demonstrate with the following example: Suppose you purchased 10,000 shares of DOW index ETF (The Diamond Trust, DIA) for \$120 a share. There is a 50% probability that the ETF price will be \$150 by the end of the year. There is also a 50% chance that the ETF will be worth \$110 at the end of the year. The expected price of the stock is \$130. The expected return for holding the ETF until the end of the year would be 8.34%, with a standard deviation of 23.65% for the expected return. Next, we assume that the portfolio manager is cautious about large declines in the portfolio and wants to buy protective puts. Assume that the price for the \$120 put that matures in one year is \$5. The total cost of the underlying asset and the put option is \$125. If the ETF price turns out to be \$150, the put would expire worthless and the ETF would be worth \$150. The investment return would be 20%. If the ETF price falls to \$110, the option would be worth \$10. The net loss of the option and ETF combination would be -\$5. The investment return would be -4%. The expected return would be 8% and a standard deviation of 12%. The protective put portfolio produces lower risk for this particular portfolio.

The above discussion, however, is incomplete because it ignores the risk that is being transferred to the put option writer. The option writer would make 100% profit if the stock price is \$150 and would

lose 100% if the stock price is \$110. The expected return for the option writer is 0%, with a standard deviation of 100%. Since the total investment of these two counter parties combined is \$125, the option writer's share is \$5 (or 4%). Therefore, the contribution of the overall risk from the option writer is 4%. The combined risk is 16%, still much lower than the 23.8% of a portfolio that consists of stocks only. However, each additional unhedged option contract would contribute 8% ($4\% \times 2$) more risk to the market. All else being equal, it would take just 100 unhedged put options to create a greater risk for the market. The impact of call options to overall market risk can be analyzed in similar manner. In markets in which derivative trading is relatively small compared with the trading activities of the underlying assets, derivatives can indeed reduce market risk. However, when a market is dominated by speculators (or investors who used only derivatives), the market risk can be greatly increased as a result of the derivatives trading (Soros 2008).

Another largely ignored impact of option trading is the implied volatility calculated by Black-Scholes Equation (Black and Scholes 1973). While the volatility of the underlying asset is a factor in determining the price of the option, future price volatility is not observed and thus can be obtained by given option prices. Thus, an increasing demand for option that drives up the price of options would also drive up future volatility. On April 8, 2010, former Treasury Secretary Robert Rubin told a Senate Panel investigating the credit market collapse in 2008 that the Treasury knew of potential large spillover of risk from derivative markets as early as 1987, during the market crash in October of that year. Yet nothing has been done to prevent such spillover effect more than two decades after the fact. Meanwhile, Long Term Capital Management managed to expose itself to more than \$1 trillion of derivative bets in 1997 that almost brought down the world's financial markets.

Speculative activities in derivatives markets not only did not decline after the Long Term Capital Management failure, it grew substantially because the government refused to increase regulation in derivatives markets. There are at least two derivatives markets in which speculations had led to large increase in spot price for the underlying asset, or created substantially more risk in the market.

The first example is the crude oil futures market. Oil futures can be used by many producers that require petroleum products or byproducts. One such candidate is the airline industry. There is no jet fuel futures market. To hedge their exposure to fluctuating oil price, an airline can enter into oil futures contracts to offset gains/losses from higher/lower jet fuel price. The oil futures market, however, saw an

increase in trading volume of over five times in just a few years (2004 to 2009). From 1984 to 1994, the number of oil futures contract trade daily remained flat (under 100,000 contracts). From 1994 to 2004, the number of contracts trade grew by 50% (under 150,000 contracts daily). By 2009, the average daily volume exceeded 600,000 contracts (400% growth in just 5 years versus 50% over the previous 20 years). Theory suggests that increases in trading activities should reduce price volatility. The spike in trading activities in the oil futures market had exactly the opposite effect (Bekiros and Diks 2007).

After oil prices reached more than \$60 a barrel shortly after Hurricane Katrina devastated New Orleans, portfolio managers started adding oil futures in their portfolio to participate in the oil commodity market. The spike in trading activities caused the basis to be negative (cash price lower than futures price), volatilities greatly increased and oil price hit all time high in 2008 and has the most spectacular fall in prices in the same year. A plot of increases in trading volume and increases in oil price show a very strong correlation from 2005 onwards.

The unintended consequence of the spikes in crude oil future prices is higher food prices (Masters 2008). Because of the artificially high oil prices, ethanol (substitute for gasoline) usage increased drastically from 2005 to 2008. Since most ethanol derives from corn, a large amount of farmland was used to plant corn, thus reducing available land for other crops. Corn is also a main feed for hogs, cattle, and chicken. As a result, volatility in futures markets for many commodities went up drastically from 2005 to 2008.

The second example is AIG's involvement in the CDS market, which most believed had contributed greatly to the credit market crash in 2008. A CDS is an agreement between two parties to exchange cash flows. The buyer of CDS is generally lenders/creditors who want to protect the cash flows from their loans. The writer of CDS can be any large financial company that has large enough capital to underwrite. The buyer agrees to pay a certain percentage to the writer when the loans perform normally. When any of the loans is in default, the writer agrees to assume the cash flows the borrower is obligated to pay the lenders. The writer will get the cash flows from the now defaulted loans. CDS is essentially an insurance policy for lenders to be compensated in the event that the borrowers default on their loans. As long as the borrowers do not default on their loans, the underwriter can collect the insurance premiums and increase the company's profit. The CDS market allows lenders to become somewhat reckless and generate loans that they would not generate if they were no CDS available to them.

The price for the CDS is supposed to be directly related to the credit quality of the borrower's credit worthiness. As it is a relatively

new derivative product and the housing market was in a bull market, the CDS contracts were greatly underpriced. If this derivative contract is only used by true hedgers, AIG will be the only speculator in this market and the total risk would be far less than what now realized. The problem was AIG was writing CDS contracts to just about anyone willing to buy. Speculators were able to short the financial instruments (mortgage-backed securities) that were not being traded. The end result was AIG was underwriting far greater CDS than it should and, as the housing market started to collapse, the true risk AIG was exposed to was realized in 2008. Although the value of the subprime mortgage market was less than \$2 trillion by the end of 2007, the value of all CDS contracts exceeded \$4 trillion. It was essentially a market full of speculators. Not only did the CDS market not reduce or redistribute risk, it created far greater risk, and most of the risks were concentrated in one financial institution. Without the intervention by the Federal government, AIG would have collapsed and could have created a far more devastating effect on the credit market than the collapse of Lehman Brothers.

Conclusion

In this paper, I have presented some examples of how derivatives can reduce market risk when use appropriately. I also demonstrated the potential for derivatives to contribute greater risk to the market when it is mostly used as speculative instrument. The theoretical argument that derivatives can reduce risk assumes an efficient market with many true users and relatively few speculators is largely an academic argument. In reality, speculators will flood the markets that are easy to manipulate. Gilbert (2010), Soros (2008), and Masters (2008) provide ample evidence that the world in practice is greatly different from the academic world. The collapse of AIG from participating in the CDS market suggests that even large financial institutions with supposedly smart researchers could not understand the real risk these contracts presented. This suggests that perhaps we should rethink how derivatives contracts are being presented in finance textbooks. Speculation in derivatives market is common in practitioner's world. Let's study the derivatives market where speculators have larger influences on risk.

References

Bekaert, Geert, Marcio G.P. Garcia, and Campbell R. Harvey, 1995, "The Contribution of Speculators to Effective Financial Markets," Catalyst Institute.

Bekiros, Stelios and Cees G.H. Diks, 2007, "The Relationship between Crude Oil Spot and Futures Prices: Cointegration, Linear and Nonlinear Causality," Universiteit van Amsterdam CeNDEF Working Paper #07-11

Besant, Lloyd, 1985, *Commodity Trading Manual*, Chicago Board of Trade, Chicago, Illinois

Black, Fischer, and Myron S. Scholes, 1973, "The Pricing of options and Corporate Liabilities," *J. Polit. Econ.*, 81, 637–645.

Bodie, Zvi, Alex Kane, and Alan Marcus, 2009, *Investments*, 8th edition, McGraw-Hill Irwin, New York, New York

Davis, Ann, 2008, "Vitol Lays Out Role in Oil Market", *The Wall Street Journal*, December 24, 2008.

Gilbert, Christopher L., 2010, "Commodity Speculation and Commodity Investment," Global Commodities Forum, Geneva, March 2010

Hull, John C., 2008, *Options, Futures and Other Derivatives*, 7th edition, Prentice Hall, Upper Saddle River, New Jersey

Harris, Larry, 2003, *Trading and Exchanges: Market Microstructure for Practitioners*, Oxford University Press, New York

Jordan, Bradford D., and Thomas W. Miller, 2009, *Fundamentals of Investments*, 5th edition, McGraw-Hill Irwin, New York, New York

Masters, Michael W., 2008, Testimony before the U.S. Senate Committee of Homeland Security and Government Affairs, Washington, DC, 20 May 2008.

Ross, Stephen A., 1976, "Options and Efficiency," *Q. J. Econ.*, 90, 75–89.

Soros, George, 2008, Testimony before the U.S. Senate Commerce Committee Oversight Hearing on FTC Advanced Rulemaking on Oil Market Manipulation, Washington D.C., 4 June 2008.

Strong, Robert A., 2009, *Portfolio Construction, Management and Protection*, 5th edition, South-Western College, Mason, Ohio

Complex Job Structure and Intelligence: A Research Proposal

Christopher Michael Nelson
Utah Valley University

Abstract

While engaging in complex activities, there is an increase in fluid intelligence. This increase in intelligence is facilitated by neural plasticity which takes place within the Lateral Prefrontal Cortex. This paper is a research proposal that will either support or not support the relationship between complex job-like activities and fluid intelligence, as facilitated by neural plastic mechanisms in the Lateral Prefrontal Cortex. This proposal outlines literature to support this thesis, methods for testing neural plasticity and intelligence, possible participant qualifications, and other details that will be useful when conducting this study. The information gained from this study may result in greater awareness of the importance of engaging in complex activities; specifically those found in the workplace.

Introduction

In Aristotle's Nichomachean Ethics, the use of one's reason is essential in achieving and sustaining well-being (Jackson 2007). The use

of reason can be seen as using one's intellect or intelligence, and it is the use of the intellect that increases one's well-being. Well-being is expressed empirically by the absence of physiological and psychological strain, decreased somatic complaints, and decreased depression (Shaw 2004).

Because many adults spend the majority of their lives at work, it logically flows that having a complex job, one that requires the intellect to be used, would be beneficial to one's well-being. This paper outlines a research model whereby the relationship between complex job structure and intelligence may be empirically observed. For years, complex job structure and intelligence have been studied separately; however, there has never been a specific study designed to link the two. This paper provides evidence in support of the idea that a correlation between complex job structure and intelligence does exist, as observed by neural plasticity.

Definition of Complex Job: Dependent on the Individual

The definition of a complex job makes it a concept that is tailored to the individual. Based on the individual's skills, attributes, handicaps, and other factors, a job may be termed as being complex. Thus, when we talk about a complex job, it is not contained within a specific industry or exclusively one that requires extreme intelligence; rather it is one that uses the full capacity of the individual (Klimoski and London 1975). To one individual, a complex job may consist of complex mathematical theory and the designing of intricate structures using engineering principals; however, to another individual, the use of basic mathematics and elementary teaching principles may be just as complex. Consequentially, the pairing of individuals with jobs appropriately complex to them is more important than the type of job chosen (Carless 2005). If a job is overly complex it may have the opposite effect on well-being (Carless 2005). This may be the most difficult aspect of this study—the pairing of individuals with a job that to them is considered complex.

Complex jobs have been described in the literature for decades (Klimoski and London 1975; Ganzach 1998; Shaw 2004), and a composite definition can be developed from several of the definitions. Job complexity is the extent to which a job challenges and requires the skills, knowledge, autonomy, social intractability, and responsibility for resources, both human and nonhuman, of the individual, as well as the extent to which it challenges and requires the individual's ability to produce novel ideas and formulate objectives and strategies that lead to

the initiating and completing of specific tasks. Job complexity is also determined by the extent to which it promotes the further development of the abilities and attributes previously mentioned. In short, job complexity is defined by the extent to which it uses the full capacity of the individual (Klimoski and London 1975).

Person–Job Fit and the Consequences of Misfit on Well-Being

The results of this study are expected to be consistent with the theory of person–job fit. Person–job fit describes the effects of the fit or misfit between one’s abilities and the requirements, or complexity, of one’s job (Carless 2005; Ehrhart 2006). The greater the misfit between one’s abilities and the job’s complexity, the more the individual will experience a lack of well-being. Conversely, the greater the fit, the more that job will contribute to the individual’s well-being (Carless 2005; Billsberry 2005).

The Gravitational Hypothesis states that “...individuals will move over time to occupations that match their cognitive ability...” (Wilk and Sackett 1996). This theory adds depth to the theory of person–job fit in that it shows how one’s person–job fit will most likely become more accurate over time and with the attainment of each new job. A common problem with hiring is that often a poor person–job fit is not perceived by the employer or employee, and thus some employers offer individuals jobs that are not a good fit, and individuals accept jobs that are a poor fit. If the relationship between person–job fit and well-being is better understood, then there may be more caution taken when accepting a job and extending a job.

The Peter Principle, otherwise known as occupational incompetence, occurs when “[an] employee [has] been promoted from a position of competence to a position of incompetence” (Peter and Hull 1994). The Peter Principle has relevance in the study of job complexity and well-being because it is an example of a common problem regarding person–job misfit. As seen by the Peter Principle, there is a limit to how much complexity in a job will lead to well-being. At a certain point, one’s abilities will not be adequate to perform according to the job’s level of complexity, and a decrease in well-being will result (Carless 2005; Ehrhart 2006).

From these theories involving job complexity and well-being, it is apparent that having an appropriate fit between one’s abilities and one’s job complexity plays a key role in well-being. Since no job will fit the exact abilities of a specific individual, there is a need for the individual to bridge the gap between his or her abilities and the job’s

complexity. Positive job performance is the factor that allows one to experience well-being from a somewhat close, although imperfect, job fit (Shaw 2004). If the mismatch between employee ability and job complexity is too great, not even positive job performance can bridge the gap. On one hand is occupational incompetence, the job being too complex for the individual's abilities, and on the other hand is occupational overcompetence, the individual's abilities far exceeding the complexity of the job. Both of these misfits hinder the individual's well-being.

Defining Complex Activity and Non-Complex Activity

In this study, two activity sets have been created to test the different effect each activity set has on the participants. One activity set will be defined as being complex, administered to the treatment group, whereas the other will be defined as being noncomplex, administered to the control group.

Earlier in the paper, complex activity was simplified to be defined as the extent to which it uses the full capacity of the individual (Klimoski and London 1975). Complexity will vary with each individual because of the skills, attributes, and mental capacities they contain. Participants in this study will be selected from similar employment backgrounds, which will require that only two activity sets be used in the study—one that is complex, and another that is noncomplex. Activities were chosen that would be similar to activities done in the office for administrative assistants, except that the activities for one group will be more complex than those for the other.

The complex activity set will consist of activities that include concept formation, goal setting, problem solving, decision making, unitizing, relating, creating, and ordering (Van Gigch 1970). The variety and integration of the activities will ensure that the participants are not simply acting by routine but that they are being required to develop new skills and deepen existing skills. This "...higher level of integration implies more complexity of mental function and hence a higher rate of information processing" (Van Gigch 1970).

The noncomplex activity set will consist of activities that facilitate an environment where "[n]o learning or judgment is involved." (Van Gigch 1970), and likely one that is more simple than each participant's own work environment. These activities are not meant to challenge the mind, require unique responses or actions, or be particularly interesting to the individual. These activities will be used to show the difference between engaging in complex activities as opposed to noncomplex activities on the lateral prefrontal cortex's development.

Relevance of Intelligence

The impact that using one's intelligence has on one's well-being is important when considering the amount of stress and depression present in modern-day Western societies (Greenwald 2009). If one is not able to apply intelligence in meaningful ways throughout one's life, how will this affect that person's well-being over time? Based on Aristotle's logic, and as has been discussed previously regarding the Person–Job Fit theory, that person's well-being will be seriously compromised.

Each individual's unique neural makeup is due in large part to the memories they have acquired over a lifetime (Thompson 1986). “Lasting changes in behavior resulting from prior experience can be characterized as the result of learning, memory, and retrieval processes” (Thompson 1986). Intelligence cannot be termed as simply as one essence or a single factor; instead, it is the sum of many cognitive abilities (Das 2002). Intelligence can be thought of as the accumulation of and interrelatedness of planning processes, attention or arousal, simultaneous processing, and successive processing or integrating stimuli (Das 2002). Memory and learning are components of each of these factors of intelligence. The following section shows how neural plasticity mechanisms facilitate the acquisition of intelligence as stimuli are encountered.

Fluid intelligence, “...reasoning and novel problem solving ability...” (Gray and Thompson 2004), is the specific kind of intelligence being discussed in this paper. This kind of intelligence relates to a specific area of the brain that will be described later on. Fluid intelligence is associated with working memory, “[a] cognitive/neural system for maintaining information actively in mind (storage) and manipulating it (executive processing), or hold it in mind despite potential distraction or interference (control of attention)” (Gray and Thompson 2004), whereas some definitions of intelligence (i.e., crystallized intelligence) relate to static knowledge and do not focus on the adaptability of intelligence. “Performance on [measures of working memory capacity] predicts performance on a wide range of higher-order cognitive tasks...including reading comprehension, complex learning, and reasoning” (Engle 2002).

Neural Plasticity: Facilitating the Acquisition of Intelligence

The mechanisms of neural plasticity make the acquisition of new knowledge, and the organizing of existing knowledge, possible

(Ansermet and Magistretti 2004). Neural plasticity is complex, and our understanding of it is expanding constantly. In this paper, neural plasticity will be considered and referred to often as the mechanism that allows for fluid intelligence to be developed; however, some of the specific mechanisms of neural plasticity will be focused on only briefly.

Activity, regardless of its complexity or relevance to productivity, causes neural plastic mechanisms to create changes within the neural structure and function of the brain (Ansermet and Magistretti 2004, Rubinov et al. 2009). Even after activity is translated into a change in the brain, by way of neural plastic mechanisms, these “memories” are adjusted so they are in closer connection with more similar “memories” and in less close connection with less similar memories (Rubinov et al. 2009). Thus, as time goes by, acquired memories are organized, involving them in functional networks with more ordered characteristics (Rubinov et al. 2009); however, memories that are not accessed often may be discarded over time (Massey and Bashir 2007).

Complex job-like activities are the stimuli used in this study to spur the neural plastic mechanisms. Complex job-like activities will be contrasted with noncomplex job-like activities to provide evidence for a disparity between the affects of each upon the individual’s neural development. The mechanisms of long-term potentiation, long-term depression, synaptogenesis, neurogenesis, and homeostatic and intrinsic plasticity will be described briefly below. The brain uses multiple neural plastic mechanisms simultaneously to create organization and stability within its plethora of neural networks. “Somehow these mechanisms must work together to allow the brain to learn efficient representations for the various tasks it is facing. They shape the neural code and form the foundation on which our higher cognitive abilities are built” (Lazar et al. 2009). Some neural plastic mechanisms are directly involved with the allocation and storage of memories (Silva et al. 2009) and are thus of great importance to this study.

Long-term potentiation (LTP) is the neural plastic mechanism that causes synapses to be retained in neural networks (Morris 2003). Synapses that experience increased activity are retained by the mechanism of LTP (Zukin et al. 2009). LTP is exhibited as “[a] brief tetanic electrical stimulus...to certain pathways [which] induces an increased synaptic excitability” (Thompson 1986). LTP is of particular interest in this study because it is connected to memory: “...the persistence of LTP correlate[s] with the persistence of memory...” (Morris 2003). As synapses experience increased activity, indicating that they are used often and that they are important to the brain’s functioning, LTP facilitates that those synapses be protected and experience growth (Morris

2003). This LTP also facilitates that the synapses nearby the synapse, experienced increased activity, be potentiated as well (Silva et al. 2009).

One of the roles of long-term depression, on the other hand, is essentially to eliminate synapses, as directed by neural activity. Synapses that have remained inactive for some time may experience a silencing and reduction in size because of LTD (Lisman 2003, Zukin et al. 2009, Minerbi et al. 2009). LTD contributes to the removal of old memory traces as they are no longer needed and as new memories are being stored (Massey and Bashir 2007).

“The combination of [LTP and LTD] contributes to the essential brain function of learning and memory. Impaired synaptic activity almost certainly results in impaired mental development.” (Zukin et al. 2009). Over time, as synapses are incorporated into neural networks, they experience a phenomenon known as drift. Synaptic drift is observed as synapses increase or decrease in size partially as a result of activity and also as a result of a lack of activity. Synaptic drift “...promot[es] the convergence of synaptic sizes on some optimal size distribution” (Minerbi et al. 2009). A network may also drift in relation to its function. This network drift can be seen as “...an ‘exploratory’ process that that allows networks to explore the space of synaptic configurations in search of appropriate synaptic input levels or functionally ‘useful’ or ‘successful’ configurations” (Minerbi et al. 2009).

The birth of new synapses is called synaptogenesis. This is not an uncommon phenomenon since “...new, small synapses are continually formed at a constant rate...” (Minerbi et al. 2009). These new synapses begin their existence without strong connection to any specific neural network; however, as time goes on, and as activity guides the need for new synapses, these synapses are stabilized, most likely by forming interactions with nearby neurons (Minerbi et al. 2009). As even more time goes by, if the neural networks that these new synapses are incorporated into experience an adequate amount of activity, the synapses will grow and become mature (Minerbi et al. 2009).

Neurogenesis, the birth of new neurons both in the child’s brain and the adult’s, is a far less common experience when compared to synaptogenesis. These new neurons are highly excitable, have high levels of synaptic potentiation, and are more susceptible to being incorporated into new memory traces, and as a result are believed to play an important role in memory development and storage (Silva et al. 2009). These new neurons have sufficiently mature synapses and overall physiology at four weeks old to be involved with connections leading to memory allocation and storage (Silva et al. 2009). The storage of

memories is thought to take place in the synapses of neurons, specifically when the neurons are newly formed (Silva et al. 2009).

The constantly changing functional and structural networks of the brain, enacted by its own self organization, will lead to neural chaos unless homeostatic plasticity mechanisms are in place (Turrigiano and Nelson 2004, Lazar et al. 2009). “The key to the brain’s solution to [this neural chaos] may be the synergistic combination of multiple forms of neuronal plasticity” (Lazar et al. 2009). Homeostatic mechanisms are believed to be the means of regulating the constant neuronal changes taking place on the synaptic level, whereas intrinsic plasticity mechanisms regulate plasticity at the neuron level (Lazar et al. 2009). These regulatory forms of neural plasticity allow the networks in the brain to learn to better organize themselves, remain efficiently organized as new stimuli are incorporated into the network, and execute prediction tasks better than if there were no regulatory mechanisms in place (Lazar et al. 2009). Homeostatic and intrinsic plasticity mechanisms are vitally important to the brains ever-changing, but continually stable, state. Without these mechanisms the brain would likely exhibit seizure-like bursts of activity and/or amnesia (Lazar et al. 2009).

We will refer to neural plasticity as being positive when it increases the “...integrity, structure, and function of the lateral prefrontal cortex” (Gray and Thompson 2004). This correlates to a greater view of positive neural plasticity—that it is neural plasticity that increases the individual’s memory, learning, and fluid intelligence, aiding in the accomplishment of goals, tasks, and ultimately, success. The term “positive neural plasticity,” as it has been defined in this paper, applies only as a descriptive term and is not documented in other related literature and/or studies.

Lateral Prefrontal Cortex: Area of Interest Regarding Intelligence

The areas of the brain being monitored in this study are found within the lateral prefrontal cortex. This general area has been speculated as being a good indicator of fluid intelligence. “Overall, intelligence in the sense of reasoning and novel problem-solving ability is consistently linked to the integrity, structure and function of the lateral prefrontal cortex and possibly to that of other areas.” (Gray and Thompson 2004).

The frontal cortex shows activation when the individual undergoes “...feature binding [...] creation of an organized structure [...] generation of images based on words [...] and integration of information in working memory” (Nyberg 2003). The lateral prefrontal cortex

is an area of the brain that deals with fluid intelligence and will be this study's indicator of participant level of fluid intelligence. An increase in the mass and structure of the lateral prefrontal cortex will indicate an increase in participant fluid intelligence, whereas a decrease will indicate a decrease in participant fluid intelligence.

When completed, this study will provide evidence that either supports or does not support a relationship between complex job structure and increased fluid intelligence. Following is a research plan that outlines the procedures that may be used to determine this correlation in a meaningful way. Following the research section is a description of methods to be used in the research process, as well as a rough estimate of costs to be expected.

Research Model

Selecting Participants

For the research to be consistent and for a single model to be followed, participants must be drawn from similar employment. Selecting participants based on their employment will allow for the same activity sets to be used for each group of participants. This will help to ensure that the amount of fluid intelligence increase is related to the complex activities being performed. It is also important to note that the neurons in the prefrontal cortex (the area of the brain being monitored in this study) are "...susceptible to age-related change, as these cells show a decrease in dendritic branching in...humans" (Burke and Barnes 2006) as well as "...decreases both [in] excitability of neurons...and the rates of neurogenesis..." (Silva et al. 2009). Hence, participant age will be of concern, as this may decrease the amount of neural plasticity seen in general, not as a result of the activity sets.

The type of employment used as a filter for participants will be administrative assistants. An individual that has been employed as an administrative assistant for at least 2 years, and that is under the age of 55 (Nyberg et al. 2003), will qualify to participate in the study. Individuals must also be currently employed as administrative assistants to qualify for participations. Participants will be selected from a single county to control for the distance they will need to travel to participate.

A questionnaire will be sent out to workplaces who hire administrative assistants, requesting the participation of these individuals. Individuals under the age of 55 that have been employed as an administrative assistant for at least 2 years and under the age of 55 will be invited to participate. As a preface to the questionnaire, a letter will include information regarding the nature of the study (basic outline with hypothesis, techniques, and compensation). The questionnaire is

the initial filtering process and will require information discussed above, as well as participant's date of birth, sex, years of formal education, and race. Although these additional questions will not be used directly in this study, they will allow the information gathered to possibly be more useful to other studies. After the selection process is completed, it is hoped that there will be at least 30 qualified participants available, 15 for each group.

Participants will be divided into two groups: those undergoing complex activities and those undergoing noncomplex activities. Each group will contain the same amount of participants, who will be randomly assigned to the groups. Each group will undergo the same number of activity sets and will receive the same information, working environment, etc. Participants in each group will undergo a positron emission tomography (PET) scan upon completing each set of activities, and data/images from these scans will be used later to detect changing brain activity correlating with the different activity sets.

Resources Available to Each Group

Each participant will be provided with a workspace that includes a chair, desk, and computer. A set of documents will also be provided both in hard-copy form and digital form. This set of documents will consist of a standard organization chart, the organization's mission statement, value statement, goals, and an employee information list. Both the complex and the non-complex activity sets were derived from the "Mental Therbligs and Levels of Integration" model described in van Gigch's article "A Model for Measuring the Information Processing Rates and Mental Load of Complex Activities" (van Gigch 1970).

Complex Activity Set

The complex activity set consists of 3 activities that participants will be required to perform. This activity set is unique because there are elements of creativity and personal reasoning that are required. There may be many ways to accomplish each task effectively, and it is up to the participant to use his or her skills, knowledge, and attributes in a way that fulfills the requirements for each task.

- **Organizing the Contact Information:** The participant is assigned to organize contacts, found on the contact information sheets, by four criteria: department, position, years experience in organization, and date of birth. This document is available in hard-copy form as well as digital form. The digital copy of the document is

stored on an Excel sheet and may be manipulated by the participant if desired.

- **Compile Minutes:** The participant is required to compile the available company minutes, showing where there is integration between sets of minutes. The format should include indication of the following: task assignment and follow up, goals and achievement, problems and resolutions, and innovative suggestions and integration of innovation.
- **Creating Teams:** The participant is required to create five different teams based on the information present in the available documents. Teams may consist of as many or few individuals as desired and may serve any purpose desired. The creation of each team should have a well-thought-out purpose. The participant is required to write a description of how teams were formulated and what purpose they serve in the company.

Noncomplex Activity Set

The noncomplex activity set is designed to allow the participant to remain occupied with “forced pace and overlearned activities” (van Gigh 1970). These activities require little, if any, creativity, reasoning, or complex skills of any kind. Each task requires the participant to do something that, in essence, only has one route to completion and only one outcome. Each participant will possess the skills, knowledge, and attributes necessary to accomplish these tasks.

- **Reading Documents Aloud:** The participant reads each document available aloud, word for word. The participant should not attempt to make sense of the documents except to simply recite what is written.
- **Retype Documents:** The participant retypes each document available, word for word. The participant should not change the formatting of the forms, but should completely replicate the format of the original document.
- **Adding Numbers:** The participant adds together each number on a single document, including the contact lists. The participant then adds together the total from each document to produce a grand total.

Detecting Changes in Intelligence

Positron emission tomography scans will be used to detect the use of and changes in participant intelligence as described previously. PET scans detect gamma rays being emitted from isotopes that have been

injected into the patient. These gamma rays allow the PET scan to detect and image many of the body's processes, including areas of the brain experiencing increased metabolism (Kapur et al. 1994). In this study, the PET scan will be able to provide a four-dimensional image of brain activity, by way of changing blood delivery to specific areas of the brain. The area of most importance in this study is the lateral pre-frontal cortex.

Methods

Condition of Participants During the Procedure

The participant will perform the activity sets in a well-lit, comfortable room with an observation window and intercom system. Each participant will be monitored by an observer (i.e., a research assistant or student aide) to ensure that any questions the participant might have are addressed. The participant will be provided with a cubicle-like desk and computer to emulate a natural setting in which the participant would actually perform their work. If the participant needs a drink, snack, or to use the bathroom, they will have access to an intercom and can request such from the observer. The observer should not interfere with the creative processes of the participant; however, if the participant requires clarification regarding an activity then the observer may assist the participant.

Administering Activity Sets

The observer will review each activity with the participant prior to starting. Once the participant has begun the activity set, the observer will keep the participant informed as to when it is time to move to a new activity. If the participant has a need or request the observer will facilitate this break, although it is hoped that no breaks will be needed. Upon concluding the activity set, the observer will escort the participant to the PET scan, and following the scan, will set up the next appointment.

PET Scans

A PET scan will be administered to each participant upon completion of each activity set. Each participant will undergo three PET scans.

Compensation for Participants

Participants will be given \$60 each time they complete an activity set, resulting in \$180 per participant in compensations over the length of the study. This will result in \$5,400 spent on participant compensation for this study.

Participant Consent and Ethical Awareness

A consent form will be given to each participant before an agreement is requested to participate in the study. This form will comply with the Institutional Review Board's (IRB) requirements, and will present each potential participant with the information needed to make an informed consent to participate in the study. The IRB's initial requirements that must be met before a review will be done are that the "[r]isks to subjects are minimized" that the "risks to subjects are reasonable in relation to anticipated benefits" and that "[i]nformed consent will be sought from each prospective subject or the subject's legally authorized representative, in accordance with, and to the extent required by the Code of Federal Regulations, Title 45, Part 46 §116" (UVU IRB Handbook 2008).

The Utah Valley University Institutional Review Board requires that procedures involving PET undergo an expedited review by the executive review board (UVU IRB Handbook 2008). This procedure requires that each participant undergo PET scans throughout the study, thus the number of PET scans and a description of a PET scan will be provided on the consent form along with information regarding potential health threats regarding each of these.

The consent form will describe the potential threats of the PET scan, as well as the potential strains the activity sets may cause the participant. The primary concern regarding the PET scan is exposure to ionizing radiation. The activity sets may require participants to remain mentally engaged in activities for multiple hours at a time. This has the potential of placing stresses on the participant that are not present in his/her daily experiences.

The consent form will also address the potential benefits gained through this study. Although there are no benefits that apply directly to the participants, there are benefits for the workforce as a whole. This study will provide evidence that complex jobs are important to the well-being of those filling them. It is hoped that employers will become more aware of the importance of complex jobs and person-job fit, and that in turn there will be more meaningful and beneficial employment made available. A monetary compensation will be made to

each participant each time he or she completes an activity set and set of scans. The amount of this compensation will be \$60 for each activity set and scan, resulting in \$180 in compensation for the duration of the study for each participant.

The participants will be made aware that their personal information will be kept confidential, and at any point during the study they are free to discontinue their participation for any reason. The nature of the data will not require that specific participants or their personal information be named in the results of the study. Code names and other forms of separating data from participants will be applied to protect the identity of the participants (UVU IRB Informed Consent Letter)

If the project is deemed by the IRB as being too dangerous for human participants because of the radiation received from the extensive PET scanning, the project may be modified by searching out other methods of neural scanning.

If the project is changed to discard the use of PET scans, then details throughout the project must be changed as well. Details in the procedure, method, and results would need to be changed so as to eliminate the use of PET scans as well as the data that would result from these scans, and any other aspects of the study deemed unethical by the IRB.

The above structure for the ethical portion of the study has been derived and modified from the UVU IRB Handbook and the UVU IRB Informed Consent Letter.

Acquiring Funds

Funding for this project may be acquired by way of a grant. Grants are offered by the U.S. Federal Government and also by private foundations. Applying for these grants will need to take place before this project can commence.

Conclusion

The expectations for this study are that PET scans will show a relationship between complex job structure and fluid intelligence. The concept of positive neural plasticity is used in this study to differentiate between neural plasticity taking place in the lateral prefrontal cortex during complex job-like activities as opposed to other parts of the brain due to other stimuli.

The procedures outlined in this research proposal are expected to be reasonable and effective. There are many variables within this study that can be changed to produce possible better results; however, it is

important to note that where there is a change in the participant population, there must also be an appropriate change made to the activity sets.

The information gathered from this study may result in a greater awareness of the importance of engaging in complex activities, including and especially, in the workplace. This kind of activity helps not only in neural development, but also in the achieving and sustaining of well-being. This study may have many valuable implications and applications regarding employment as it relates to employee well-being.

Job enrichment, the designing of a job that “provide[s] sufficient variety and challenge, and require[s] enough skill to engage the abilities of the worker” (Klimoski and London 1975), plays a key role in the possible results of this study. If the hypothesis, that complex job structure, when properly fitted to the individual, increases fluid intelligence and as a result increases well-being, is supported, then it is hoped that employers will have greater evidence to provide complex employment. The focus of an employer should be to offer jobs that are complex, according to the abilities of potential employees, and consequently to provide opportunities for appropriate gravitation into job positions within the company that will keep current employees in a close person–job fit. This will improve employee retention, development, and loyalty. In this way, the employer can benefit the lives of those that he or she employs, and in return, the employer gains their best resource, that of an increasingly intelligent and skilled pool of employees.

References

- Ansermet, F., Magistretti, P. (2004). *Biology of Freedom : Neural Plasticity, Experience, and the Unconscious*. Other Press.
- Billsberry, J. (2005). Some suggestions for mapping organizational members' sense of fit. *J. Bus. Psychol.* Vol. 19, No. 4 (Summer, 2005), pp. 555-570.
- Burke, S.N., and Barnes, C.A. (2006). Neural plasticity in the ageing brain. *Nat. Rev. Neurosci.*, Vol. 7, No. 1 (January 2006), pp. 30-40.
- Carless, S.A. (2005). Person-job fit versus person-organization fit as predictors of organizational attraction and job acceptance intentions: a longitudinal study. *J. Occup. Organ. Psych.*, Vol. 78 (September 2005), pp. 411-429.
- Das, J.P. (2002). A better look at intelligence. *Curr. Dir. Psychol. Sci.*

Vol. 11, No. 1 (February 2002), pp.28-33.

Ehrhart, K.H. (2006). Job characteristic beliefs and personality as antecedents of subjective person-job fit. *J. Bus. Psychol.*, Vol. 21, No. 2 (Winter 2006), pp. 193-226.

Engle, R.W. (2002). Working memory capacity as executive attention. *Psychol. Sci.*, Vol.11, No. 1 (February 2002), pp.19-23.

Ganzach, Y. (1998). Intelligence and job satisfaction. *Acad. Manage. J.*, Vol. 41, No. 5, pp. 526-539.

Gray, G. R., Thompson, P.M. (2004). Neurobiology of intelligence: science and ethics. *Nat. Rev. Neurosci.*, Vol. 5, pp. 471-482.

Greenwald, J. (2009). Employers grapple with rise in workplace suicides. *Bus. Insur.*, Vol. 43, Issue 30, pp. 1-22.

Jackson, R. A. (2007). Aristotle on what it means to be happy. *Richmond J. Philos.*, 16 (Winter 2007).

Kapur, S., Craik F.I.M., Tulving E., Wilson, A.A., Houle, S., Brown, G.M. (1994). Neuroanatomical correlates of encoding in episodic memory: levels of processing effect. *Proc. Natl. Acad. Sci. USA* Vol. 91, No. 6 (Mar. 15, 1994), pp. 2008-2011

Klimoski, R. J., London, M. (1975). A study of perceived job complexity. *Pers. Psychol.* Vol. 28, pp. 45-56.

Lazar, A., Pipa, G., and Triesch, J., (2009). SORN: a self-organizing recurrent neural network. *Front. Comput. Neurosci.*, Vol.3, Article 23, October 2009.

Lisman, J., (2003). Long-term potentiation: Outstanding questions and attempted synthesis. *Philos. T. R. Soc. B*, Vol. 358, pp. 829-842.

Massey, P.V., and Bashir, Z.I., (2007). Long-term depression: multiple forms and implications for brain function. *Trends Neurosci.*, Vol. 30, No. 4, pp. 176-184.

Minerbi, A., Kahana, R., Goldfield, L., Kaufman, M., Marom, S., and Ziv, N.E. (2009). Long-term relationships between synaptic tenacity, synaptic remodeling, and network activity. *PLOS Biol.*, Vol. 7, Issue 6

(June 2009), e1000136.

Morris, R.G.M. (2003). Long-term potentiation and memory. *Philos. T. R. Soc. B*, Vol. 358, No. 1432, pp. 643-647.

Nyberg, L., Sandblom, J., Jones, S., Stigsdotter, N., Petersson, K.M., Ingvar, M., and Backman, L. (2003). Neural correlates of training-related memory improvement in adulthood and aging. *Proc. Natl. Acad. Sci. USA*. Vol. 100, No. 23 (November 2003), pp. 13728-13733.

Peter, L.J., Hull, R. (1994). The Peter Principle, *The London Souvenir*, pp. 19-27

Rubinov, M., Sporns, O., Leeuwen, C.V., and Breakspear, M., (2009). Symbiotic relationship between brain structure and dynamics. *BMC Neurosci.*, 2009, Vol. 10, pp. 55.

Shaw, J.D. (2004). Job complexity, performance, and well-being; when does supplies-values fit matter? *Pers. Psychol.*, Vol. 57, 847-879.

Silva, A.J. et al. (2009). Molecular and cellular approaches to memory allocation in neural circuits. *Science*, Vol. 326 (16 October 2009), pp. 391-395.

Thompson, R.F., (1986). The neurobiology of learning and memory. *Science*, Vol. 233, No. 4767, pp. 941-947.

Turrigiano, G.G. and Nelson, S.B. (2004). Homeostatic plasticity in the developing nervous system. *Nat. Rev. Neurosci.*, Vol. 5 (February 2004), pp. 97-107.

Utah Valley University Institutional Review Board Informed Consent Letter. <http://uvu.edu/irb/lib/includes/Sample%20Consent%20Form.pdf>

Utah Valley University Institutional Review Board Investigator's Handbook for Research Involving Human Subjects. (2008). Revised January 12, 2009. <http://uvu.edu/irb/lib/includes/IRB%20Handbook%20%28pdf%29.pdf>

van Gigch, J.P., (1970). A model for measuring the information processing rates and mental load of complex activities. *CORS Journal*, Vol. 8, Issue 2, p. 116-128.

Wilk, S.L., Sackett, P.R. (1996) Longitudinal analysis of ability-job complexity fit and job change, *Pers. Psychol.*, Vol. 49, Issue 4 (Winter 1996), pp. 937-967.

Zukin, S.R., Richter, J.D., and Bagni, C. (2009). Signals, synapses, and synthesis: how new proteins control plasticity. *Front. Neural Circ.*, Vol. 3, Article 14, October 2009.

Engaged Learning and the Entrepreneurial Mind Set

Peter B. Robinson

Utah Valley University

Abstract

While some argue that entrepreneurship cannot be taught, it is usually the entrepreneurial mindset they would insist is not teachable. This mindset is often based on older theories that are usually outdated or inconsistent with current theories and assumptions. This paper presents a conceptual and empirical tie between engaged learning and the entrepreneurial mindset using a model of the mindset based on current attitude theory, as exemplified by the Entrepreneurial Attitude Orientation (EAO) as an example of entrepreneurial mindset. Engaged learning models are explored in terms of both (1) the elements of good engaged learning and (2) the steps involved in engaging students in the learning process. Finally, two examples of engaged entrepreneurship education are provided and related back to the elements of engaged learning.

It Just Can't Be Taught: an introduction to entrepreneurial mindset

On December 20, 2009, Derrick Rose of the Chicago Bulls had what was described as “A Dream Shake.” He drove hard to the basket, pushing the defender back, he slid to the side, stepped back, spun, and jumped, nailing two points, and there was virtually nothing the defender could do. It was a pressure shot at a key point in the game, and he made it. That move sparked an interesting conversation on the Fan Shot - Comments page of the Blog-a-Bull web site (Dec 20, 2009).

A poster, “Option27,” posted the video with the comment “There’s just some things you can’t teach,” and the following thread ensued (word choice, punctuation, and spelling unedited).

tyger1147: Um... you think that's not something that can be taught?

Option27: I honestly don't. That play displayed so much. Agility, natural athletic ability, speed, awareness, creativity and most of all, the pressure to make such an important shot whilst all the chaos involved in that play.

SoulEater7: I think it can be taught. But it takes Agility, natural athletic ability, speed, awareness, creativity, and timing to pull it off.

Option27: If you have all those attributes, then yes . . . it can be taught. But those abilities are what cannot be taught. Got my point?

SoulEater7: Oh I thought you meant the move couldn't be taught.

Option27: I just meant the whole process of the play and what you would need to pull it off.

tyger1147: In that sense, nothing can be taught??? I realize I'm getting sucked into a vortex of the unknown here, but whatever.

Option27: That was deep.

There have been similar discussions with regard to entrepreneurship. We could observe the founding of a company where the founders identify a great opportunity that nobody else had seen. They marshal the resources, raise the capital, and launch the successful venture while the larger community watches in awe as the pundits step in.

Pundit 1: There are just some things you can't teach,

Pundit 2: You think that's not something they teach at Utah State, BYU or the U?

Pundit 1: I honestly don't. That displayed so much knowledge, foresight, gut instinct, innate ability and street smarts; to start that business under our current economic conditions, it just can't be taught in an MBA class and certainly not at the undergraduate level.

Pundit 3: I think it can be taught but it takes knowledge, foresight, gut instinct, innate ability and street smarts to pull it off.

Pundit 1: If you have all those attributes, then yes . . . it can be taught. But those abilities are what cannot be taught.

Pundit 3: Oh I thought you meant that entrepreneurship couldn't be taught

Pundit 1: I just mean the whole process of creativity, generating ideas, identifying, evaluating and executing opportunities, and building a successful organization, and the attributes you would need to pull it off can't all be taught.

Pundit 2: In that sense, nothing can be taught. I realize I'm getting sucked into a vortex of the unknowable here, but whatever.

Pundit 1: That was deep.

The Things That Can't Be Taught

There does seem to be some set of characteristics that set entrepreneurs apart from managers, wage, and salary workers. Some set of at least quasi-innate abilities that can collectively be called the entrepreneurial mindset. The question then becomes, what is the entrepreneurial mindset?

In the popular press there are as many definitions or formulas for the entrepreneurial mindset as there are consultants, researchers, and educators. A Google search turned up 250,000 results in 0.39 seconds, and while there was a great deal of redundancy, the list was impressive. Even when the search is limited to scholarly research on the entrepreneurial mindset, there were over 23,000 results.

Just some of the attributes of the entrepreneurial mindset from both popular press and scholarly publications include (Google Scholar; Gibb, 2002):

Free thinkers,	A passion for business,
Problem solvers,	A product/customer focus,
Innovative in their approach to change,	Tenacity,
Willing to fail to eventually win,	Execution intelligence,
Take calculated risks,	Achievement motivated / oriented,
Learn from failure,	Alert to opportunities,
Passionately seek new opportunities,	Creative,
Strong personal discipline,	Decisive,
Focus on execution,	Energetic,
Work through others,	Internal Locus of Control,
Excel at planning.	Risk taker,
	Networking ability,

Persuasive,	Strong work ethic, and
Self confident,	Tolerance for ambiguity
Self-starter,	

The list could go on indefinitely. The problems with the popular approach and often with scholarly research are:

- First: It is often based on individual experience with little or no empirical support.
- Second: There is no theory base, and when there is a theory base, it often uses theories that are older not generally accepted in the home discipline.
- Third: The characteristics or mindset, while it may be true that entrepreneurs in general possess the attribute, it does not distinguish them from managers, wage and salary workers, or the general population.
- Finally: So what if entrepreneurs possess the attributes? Is it of any utilitarian value?

Focusing on the second problem, the lack of theory and use of older outdated information (Robinson and Shaver, 1995) noted that this has resulted in “a considerable amount of folklore and myth embedded in popular and some scholarly conceptualizations of the entrepreneur” (p.98). Older conceptualizations tend to be based on assumptions consistent with traits and personality types that are not in harmony with reality and more current social science theories. The lack of empirical support for traits and types has led to a focus on firm level strategy and the behavior of the entrepreneur (Endres and Woods, 2006; Gartner and Carter, 2003; Ross and Westgren, 2006). The result has been the conclusions that “there are some things that just can’t be taught.”

This conclusion is true, if education is based on the older conceptualizations and models in which entrepreneurs are considered to have innate characteristics such as a need to achieve, internal locus of control, or a certain Myers-Briggs personality type. The resulting educational programs would then be lecture- and text-based case studies, memorization of terms and concepts, story problems, and very little

practical application. The focus is on skill building, behavior parroting, and appropriate responses to outside stimulus.

This conclusion is false if education is based on newer conceptualizations and models of the human experience. This paper will explore these newer conceptualizations and the type of education that will naturally arise from current social psychological theory.

A New Approach Psychological “Things”

Before exploring the “things” of education and entrepreneurship, there must be some exploration of the “things” of psychology (theories and frameworks) and the “things” of entrepreneurship (Mindset).

Starting with psychological “things,” in 1989, Mitchell and James (1989) described “a new view [of psychology] that stresses the important attributes of people, their contexts, and their interactions.” They listed several points that defined the relationship between the person and the environment. These points are: (1) the person fitting into an environment; (2) both the person and the environment changing over time; (3) changes in the person causing changes in the environment and changes in the environment causing changes in people; (4) people being both active and reactive with respect to these changes; and (5) people’s views of their past and future influencing whether they are active or reactive and how much or how little they change.”

Again, Mitchell and James state that, “what emerges is a human who is active psychologically and behaviorally, interacting in a dynamic way with a changing environment. For the person, there is both stability and change, there is [pro] active and reactive behavior, [and] there are abilities and acquired skills that merge” (p. 147).

This view became part of the foundation of a more current stream of theories that provides for characteristics that must be dynamic, changing across both time and situations, that are learned through experience, and that interact with the environment. The primary thrust of this line of research in entrepreneurship is attitude theory as conceptualized by Robinson et al. (1991).

The “Things” That Need To Be Taught?

Next, the “things” of entrepreneurship, those things to be taught, depend on the conceptualization and definition of entrepreneurship. In 2000, Shane and Venkataraman (2000) examined the literature across multiple business disciplines looking for those activities that distinguished entrepreneurship from every other business discipline (strategy, organizational behavior, organizational development, organ-

izational theory, etc.), and they found three defining activities that were unique to entrepreneurship: (1) opportunity identification; (2) opportunity evaluation; and (3) opportunity execution.

This took entrepreneurship from a knowledge base or skill set to a process. It moved the “things” that define an entrepreneur from a static, stimulus response set of traits and behaviors to a dynamic, interactive mindset consistent with the description of Mitchell and James (1989). It made it appear, at first, as though these “things” really couldn’t be taught. What it actually did was to clearly define what processes constitute the field of entrepreneurship and challenged the field to find ways to model, measure, and teach those processes.

It clarified what many had been advocating for some time. Models of entrepreneurial characteristics must be based on current theory and founded on accurate assumptions of how people interact in their environment (Carsrud and Johnson, 1987; Robinson and Shaver, 1995). Entrepreneurship became an intention and an inclination, not just an action or set of behaviors. It had become a mindset not a skill set.

The Entrepreneurial Mindset and Attitude Theory

Mindset is often defined as an established set of attitudes held by someone, that influences or predisposes an individual to interact (perceive and behave, act and react) with the world in a certain and consistent way. It is synonymous with an intention or inclination, a frame of mind, an approach or an outlook. Operationalizing constructs such as “mindset” has been the domain of social psychology for decades and is best embodied in research dealing with attitudes.

Attitude is the predisposition to respond in a generally favorable or unfavorable manner with respect to the object of the attitude (Ajzen, 1982; Huefner, 1991; Kristensen et al. 2001; Robinson et al. 1991; Rosenberg and Hovland, 1960; Shaver, 1987). Attitude is a dynamic construct, changing over time and acquired through experience. In the field of entrepreneurship the best embodiment of this framework is the Entrepreneurial Attitude Orientation (EAO) developed by Robinson (1987) as part of his doctoral dissertation. It is the most widely used and cited attitude measure in the field.

The EAO consists of a constellation of four related attitude scales the objects of which are a psychological construct representing a way of interacting with the world in the context of business. Together they constitute a measure of the entrepreneurial mindset. It should be noted that the EAO does not measure one’s attitude toward entrepreneurship. Rather it measures four business-based attitude scales that are highly related to entrepreneurship. These four scales are:

1. **Achievement in business**, referring to concrete results associated with the start-up and growth of a business venture.
2. **Innovation in business**, relating to perceiving and acting upon business activities in new and unique ways.
3. **Perceived personal control of business outcomes**, concerning the individual's perception of control and influence over his or her business.
4. **Self-esteem in business**, pertaining to the self-confidence and perceived competency of an individual in conjunction with his or her business affairs.

Each subscale is measured using a tripartite model, which holds that people interact with and learn from their environment in three distinct but related ways, through their affect, cognitions, and conations. Attitude is a combination of all three types on interaction (Allport, 1935; Breckler, 1983, 1984; Carlson, 1985, 1994; Katz and Stotland, 1959; Kothandapani, 1971; Kristensen et al. 2001; Ostrom, 1969; Robinson, 1987; Rosenberg and Hovland, 1960; Shaver, 1987). The cognitive component consists of the beliefs and thoughts an individual has about an attitude object. The affective component consists of positive or negative feelings toward the object. The cognitive or behavioral component consists of intentions, predispositions, or inclination to behave in a given way toward the attitude object.

The EAO has been validated across dozens of studies across multiple industries, cultures, and countries (Gibson et al. 2010; Harris et al. 2007/2008, 2009; Kasselmann et al. 2002; Kassicieh et al. 1996; Rasheed and Rasheed, 2003; Robinson et al. 2000; Shariff and Saud, 2009; Shepherd and Evans, 2002; Tam, 2009; Tam et al. 1996, 2009; Van Wyk et al. 2003; Walstad and Kourilsky, 1998). It provides a strong foundation for attitudes as a viable model of entrepreneurial characteristics and for the four sub scales as components of the distinct set of characteristics that set entrepreneurs apart from the general population. It measures the entrepreneurial mindset.

How The “Things” Could Be Taught: From Education to Mindset

This model of entrepreneurial mindset has strong implications for education and training, where the objective is to positively influence those “things” in the realm of entrepreneurship “that just can’t be taught.” With support from attitude theory, it seems that those “things”

that set entrepreneurs apart, may be taught after all, if done with the right pedagogy, context, and content.

With the change in perspective advocated by Shane and Venkataraman (2000) and the adoption of a dynamic paradigm consistent with the mindset/attitude conceptualization of Robinson, learning then becomes a “process whereby knowledge and understanding¹ are created through the transformation of experience within a realistic environment” (Robinson and Malach, 2004, 2007). You can learn the “things” that define entrepreneurs by doing them and then learning from the doing.²

In education this is best achieved through actual performance of task relevant to the learning objectives (Specht and Sandlin, 1991) within a theory base or conceptual framework. This model has been a standard in the field of medicine for hundreds of years. Students of medicine are expected to learn through the “practice” of medicine, and this “practice” usually includes a “clinical setting” as part of the overall curriculum. It also follows that learning entrepreneurship would be best accomplished through undertaking entrepreneurial activities in a realistic environment.

Crosby (1995) indicated that the assumptions underlying experiential education are more reliable than those underlying traditional theories of education. By this she meant, “That students educated according to these assumptions are better prepared to deal with the world than are students educated according to traditional epistemologies (p. 4-5).”

At the foundation of this type of learning is a shift in the way students interact with their environment. Simply interacting with the environment is not enough for education. (Joplin, 1995) states that the process must include reflection. She provides a five-step model for how this interaction may be structured for maximum effect. These steps include:

Focus.	This consists of presenting the task and isolating the attention of the learner for concentration, preparing the individual for the
--------	---

¹ Defined as a quality of knowing going beyond cognitions such as facts, concepts, beliefs and principles to include connotation and affect.

² Learning by doing and learning from doing are different processes based on the structure of the pedagogy and the interaction with a conceptual framework. Learning from the doing is based in a theoretical framework that informs the actions of the learner.

challenging action that is to follow.

- Action. This stage places the learner in a stressful situation where he is unable to avoid the problem presented, often in an unfamiliar environment requiring new skills or the use of new knowledge. Actions may be physical, mental, emotional, and spiritual or any combination of several actions. Actions are student centered requiring a sustained effort in observing, sorting, ordering, analyzing, behaving, emoting, struggling, and in general interacting with the environment and the presented problem.
- Support. Support provides security and protection for the learner giving them the confidence to try new things and stretch themselves in risky situations.
- Feedback. Feedback provides information about the students' performance relative to the task and gives some guidance for future actions.
- Debrief. Here the learning is recognized, articulated and evaluated. The teacher is responsible for seeing that the actions previously taken do not drift along unquestioned, unrealized, uninterrupted, or unorganized.

The Link: Entrepreneurial Mindset and Engaged Learning

While past research has identified the elements of the entrepreneurial mindset as embodied in attitude theory and the EAO, there has been research linking the entrepreneurial mindset to education. Starting as early as 2003, Rasheed and Rasheed (2003) found empirical evidence using a pre-test, post-test experimental design for a positive shift in the entrepreneurial attitudes of inner-city youth participating in an business education program focusing on entrepreneurship.

More substantial work is emerging linking entrepreneurship education to entrepreneurial mindset. Tam (2009; Tam et al. 2009) and others (Harris et al. 2007/2008; Rasheed and Rasheed, 2003; Souitaris et al. 2007) provided empirical evidence that education affect entrepre-

neurial characteristics and particularly the entrepreneurial attitudes of the students, on top of imparting skills and knowledge embodied in a curriculum. Tam's research went on to demonstrate that:

“Students became more entrepreneurial through the confidence gained from the real-world relevant content material and the application focus of the curriculum. The mix of having practice-oriented instructors capable of blending practice with theory, frequent exposure to reputable, practitioner guest-speakers with expertise in topical areas, learn by doing through hands-on projects in collaborative teams are contributory factors.” (Tam, 2009)

This provides empirical evidence for the theoretical link between engaged learning and the entrepreneurial mindset. Based on this research we can conclude that in terms of entrepreneurship, yes, the things can be taught.

Engaged Learning in Practice

Engaged learning activities are designed to teach complex principles through the use of structured behavioral activities (Dutton and Stumpf, 1991; Thatcher, 1990). It is through these activities that the person–environment relationship with respect to cognitions, conations, and affect can be established or changed for a particular individual and a particular set of complex principles. The following are elements that will enhance the effectiveness of attitude change and thus are elements of good experiential education:

A balance of content and process: An examination of process is fundamental to experiential learning. How we solve the problem is as important as the solution in the learning process (Chapman et al. 1995; Joplin, 1995).

Student- rather than teacher-based: The teacher will create safe working boundaries and then get out of the way, placing the responsibility for learning squarely on the student (Joplin, 1995).

Personal not impersonal in nature: The learner as a perceiving, thinking, feeling, and behaving human being is placed under stress to perform in a specific situation. Individuals must be engaged in the process to bring all their faculties to bear on the problem. It must become personally relevant to them (Joplin, 1995).

Holistic rather than reductionist: Complex environmental situations facilitate learning the complexity of relationships in real world settings. Solutions must take into account the rich diversity present in

realistic environmental situations. The whole is in reality greater than the sum of the parts (Chapman et al. 1995; Joplin, 1995).

Creates an emotional investment: Any experiential learning model that does not recognize the importance of emotional investment diminishes its potential effectiveness for the learner. The processes need to engage the learner to a point where what is being experienced strikes a critical central chord within the learner (Chapman et al. 1995; Joplin, 1995).

Reflection and self examination: Experience without reflection and examination is only interaction and not education. Learners must reflect on the processes and examine their reaction to the situation and their actions (Chapman et al. 1995).

Moving outside one's comfort zone: Experiential learning often stretches the learner beyond their normal range of cognitive, conative, and affective responses. This enables them to examine their normal responses and learn new patterns of responding to situations (Chapman et al. 1995).

In summary, engaged learning is an approach whereby knowledge and understanding are acquired through a complex set of interactions between thinking, feeling, and behaving beings and a complex environment. Through this interaction relationships and theories can be explored and examined to create new insights into the practice of any specific field.

Examples of Engaged Learning in Entrepreneurship

The following are two examples of engaged learning in the field of entrepreneurship. “The Challenge” is an in-class activity based in a simulation. “Start-a Business” is a five-week out-of-class activity based in reality. Both are designed to teach complex relationships in an entrepreneurial context.

The Challenge as Engaged Learning

“The Challenge” was adapted for entrepreneurship education from part of a larger set of experiential learning activities. It has also been used for over 20 years in entrepreneurship and has been integrated into both classroom and public seminar settings with participants ranging from high school students to postgraduate students and educators. A full description of the “The Challenge” can be found in Simulation and Gaming (Robinson, 1996).

“The Challenge” is a simulation-based learning activity that involves structured scenarios within which the participants enact unstruc-

tured roles. Learning takes place through the examination of interactions between:

1. The scenario and the roles adopted by the individuals;
2. The different roles adopted by the individuals in the activity; and
3. The roles adopted by the participants and their normal mode of behavior.

The scenarios involve a strong problem-solving component, yet it is not the solution to the problem that is critical to the learning (there are multiple solutions to any scenario), but the examination of the processes involved in arriving at the solutions.

A simulation is a simplified situation that contains enough similarities with reality to elicit real-world responses from the participants (Keys and Wolfe, 1990). “The Challenge,” although it is not couched in a business scenario, can be related to the entrepreneurial process through the use and manipulation of artifacts as symbols that can represent business based concepts. First, the participants are part of a venture, an undertaking involving risk and uncertainty. The scenario goes on to introduce key variables consistent with an entrepreneurial situation, such as

1. A superordinate goal or mission to be accomplished;
2. limited resources that may change based on factors within and external to the group;
3. an uncertain outcome including the possibility of failure;
4. an ambiguous situation where the procedures are not set but must be developed by the group;
5. multiple options in terms of strategies and tactics in accomplishing the task;
6. emotional involvement and commitment to reach the objective;
7. an action imperative where participants take action often without understanding the situation.

In summary, “The Challenge” models an entrepreneurial venture along several key dimensions that can be controlled by the facilitator.

The Scenario

Participants should imagine that they have been caught behind enemy lines after recently escaping from a prisoner-of-war or concentra-

tion camp. They have hired a guide or bribed a guard to help them get back to their own territory. Their last obstacle is a very sophisticated electronic minefield. The minefield is constructed with sensors so that if one person touches any part of the ground within the field, that person and anyone else on the field or in the near vicinity is killed.

To accomplish this seemingly impossible task, the guide (facilitator) has provided the group with a number of anti-mines disguised as rocks, blocks, or other flat unstable objects that are capable of sustaining 200 to 500 pounds of pressure and can be easily picked up, carried, and tossed very short distances without breaking, chipping, or cracking.³ Individuals can place the anti-mines on the field and stand on them without triggering the mines. Several people may share one anti-mine. However, if anyone falls or steps off the anti-mine, he or she is immediately blown up—along with the entire group—and will have to return to the starting line to begin again. The group should start with two or three fewer anti-mines than the total number of people participating in the exercise.

Three specific rules must be stressed. First, because the group is trying to get across the minefield without being detected, it must do so in total silence; that is, no talking, laughing, or even whispering. Group members can communicate as long as it is not written or spoken. Second, no one may cross over the finish line until everyone is on an anti-mine in the minefield; that is, out of the starting area. If one person crosses the finish line while another is still in the starting area, it completes a circuit that blows everyone up and the whole group starts over again. Finally, there are to be no sacrifices or martyrs; everyone must exit the minefield.

The Objective

There are a few basic rules or objectives in the simulation.

First: Everyone must cross the minefield. There are no martyrs; no one can be left behind.

Second: No one can cross the finish line until everyone is out of the starting place.

³ Rocks are often used as anti-mines, but if they are unavailable, scrap lumber of about one-half square foot, cut at odd angles, may be used.

<p>Finally: There can be no talking during the activity. Normally this would include writing, whispering, or making noise. It does not include body language and gesturing.</p>
--

The Minefield

The minefield to which the group is taken is described to the participants as an area of unlimited width and variable length; in truth, it is usually an open area at least 50 yards long and 10 yards wide, ideally with grass (or carpet if indoors). At the onset, the field should be a minimum of 10 to 15 feet longer than the group could stretch if everyone in the group stood, arms spread, finger tip to finger tip, lengthwise on the field. The perception of the group should be that this is an impossible distance to cross given the resources available. The length of the field may change at any time during the activity, with the leader determining the length at any particular moment. A visible marker should be placed at both ends of the field to identify the beginning and end for the participants.

Ideally, the activity should take place outside on a lawn or grassy area with access to rocks or other objects. It also may be conducted indoors in a large hallway or gymnasium. The leader should be creative in building environmental factors such as sidewalks, ditches, landscaping, buildings, hallways, and so on, into the scenario.

The Leader

The guide has the freedom to roam across the minefield without detonating the field and (a) to add or remove anti-mines from the group for their use (only the anti-mines he or she gives to the group may be used), (b) to move the end of the minefield closer to or further from the group, (c) to catch people talking or touching the ground and send them back to the start, or (d) to forgive those who step off the anti-mine by not sending them back (this option should not be used except when there are extreme time constraints).

The group is usually rewarded (e.g., adding an anti-mine or shortening the field) when it is working together well and progressing toward the goal. It may lose an anti-mine, find the field lengthened, or get blown up when group members talk, laugh, make individual rather than group efforts, or in general are not working together and helping each other. The addition or removal of one anti-mine may seem insignifi-

cant, but after the group has been struggling for an hour or more and has become highly involved, one anti-mine can be extremely meaningful.

“The Challenge” as Applied to Engaged Learning

The challenge is engaged learning.

A balance of content and process: While the focus is on the processes involved in crossing the minefield, the participants are encouraged through to examine the process by looking for the symbols involved in the activity and relating them to the process of opportunity identification, evaluation and execution.

Student—rather than teacher—based. The facilitator (teacher) sets the parameters and enforces the rules and allows the students to develop their own strategies and tactics. The teacher may take a more active role through selective reinforcement and punishment to encourage more productive behavior.

Personal not impersonal in nature: The minefield is a stressful situation in which the participants perform unspecified tasks to accomplish specific objectives. It is personal. They must be engaged in the situation or it become obvious very quickly that the group will not succeed.

Holistic rather than reductionist: The minefield is a relatively complex situation in which students can explore ideas and strategies. Participants must think on the go, try multiple tactics and constantly adjust their actions to accomplish their objective.

Creates an emotional investment: Participants must be engaged or invested physically, emotionally, and mentally. Their emotional investment is obvious by their reaction when they fail, and they will fail, as well as when the last person comes off the minefield.

Reflection and self examination: There must be a debriefing session after the activity in which participants share the experience from their multiple perspectives. In sharing, insights are gained that participants might not have gained otherwise. This discussion can be deep and rich in terms of the content and application of principle that may have been abstract concepts up to that point in time.

Moving outside one’s comfort zone: It is not easy. It requires focused and concentrated effort to complete the task. It can be very stressful. Often, individual liabilities, particularly physical liabilities, become obvious to both the individual and the group, and both must learn to compensate for those liabilities. This is particularly true of balance.

“Start-A-Business” as Engaged Learning

“Start-A-Business” has been used for decades in teaching entrepreneurship. It is not a simulation but a reality-based activity designed to force students into an entrepreneurial act in a relatively safe, low-risk environment. There are many variations, such as “start a business with a dollar” or “the five-buck, five-week challenge”; however it is done it is intended to be a condensed experience that engages students in opportunity identification, evaluation, and execution.

Because students are seldom experienced in this level of engaged learning it must often be stressed to them that this is not an academic exercise or a plan for a business that they might start at some point but that they are to start a real revenue-generating business.

The Utah Valley University version takes the following form as described in the syllabus of the introductory class:

As a group or as an individual you will start a LEGAL and profitable business. You may have a maximum of one dollar (\$1) for each person involved in your business as start-up capital. The business must be new to you and/or the group. You may sell existing products/services in new markets or sell new products/services to current customers. Current products/services to current markets (target customers) are not acceptable.

In addition to the dollar, you may use any other resources you currently possess. If those resources are expendable (lumber, materials, cake mix, etc) they must be replaced or the replacement value subtracted from the revenue of the business. The use of capital assets (equipment, tools, computer, vehicle, etc.) is acceptable.

The sale of capital assets is not acceptable except under exceptional circumstances – see the instructor.

You will have about five weeks to complete the assignment. At the end of the time you will add up all revenues (paid and accounts receivable) and subtract all expenses (paid and accounts payable) to determine profits. Grades will be awarded on a competitive basis with the top profit performer(s) receiving 100%, the second most profitable receiving 99%, third 98%, and so on. The lowest grade you may receive on this assignment will be a "B-" if:

(1) You try to start a business. This is not a hypothetical or academic exercise. This is practice, not theory. You must

demonstrate a real effort to sell a product or service. It doesn't matter whether you make a profit, you must try.

(2) You must hand in a report, on time. Late reports will be discounted.

Results

Most students struggle with the assignment. Some go into denial for a period of time. Others spend so much time planning that there is not enough time to execute their business. In the end, most make some money.

It is common for 10–15% of a class to make over \$1000 in the five weeks with the highest profit earner coming in between \$3,000 and 5,000. On the low end, 20–30% will earn less than \$50. The majority (80%) earn more on an hourly basis in their little venture than they can make working at their normal employment, and 20–30% of the students intend to continue their venture while they are in school.

In all cases the students identify, evaluate, and execute opportunities in a relatively safe, risk free environment. Failure is possible, but the consequence is minimal. If they try and hand in a report, the lowest grade they can get is a B-, and this assignment only count for 5 to 10% of their course grade.

“Start-a-Business” as Applied to Engaged Learning

A balance of content and process: This assignment focuses specifically on the identification, evaluation, and execution of opportunities. In particular, this activity focuses more on execution than any other assignment or activity in entrepreneurship education.

Student—rather than teacher—based: The teacher sets very few parameters, allowing the students to develop their own strategies and tactics. The teacher takes a supportive but very passive role with the student responsible for “figuring it out” and making it happen.

Personal not impersonal in nature: The students are the center of the assignment. They take the risk, they enact the business, and they receive the reward.

Holistic rather than reductionist: Students must enact all aspects of the business they start. They create (or purchase) the product or service, they must market the business, and they have to account for the finances. Finances are easy—they can only use \$1.

Creates an emotional investment: Students are forced to confront their fear and anxiety relative to starting a business. Those who have

never started a business have a greater emotional involvement and have the greatest learning experience in terms of overcoming the anxiety.

Reflection and self examination: There must be a debriefing session after the activity in which participants share the experience from their multiple perspectives. Not only do they share what they did but often the excitement of discovering a new business opportunity.

Moving outside one's comfort zone: All of the students who have not started a business are forced outside their comfort zone because they have to take a risk and start something they have never done before. Risk takes many forms and in this case it becomes more of a risk to ego and self esteem than a risk of money or grade. Many who have started or owned a business in the past are similarly challenged.

Conclusion

This paper represents a strong first step in linking engaged entrepreneurship education to the entrepreneurial mindset. The paper provides insight into the type of educational pedagogy (experience-based or engaged learning) that is likely to have the strongest effect on increasing the strength of the entrepreneurial mindset as conceptualized by the attitude model.

This entrepreneurial mindset model (based on Robinson's attitude consistency model (Robinson, 1987; Robinson et al. 1991) is important for several reasons. First, it provides a dynamic framework for understanding the dynamics of an entrepreneurial career. Second, it provides insight into the educational practices that will influence the entrepreneurial mindset. Third, it can be used to assess the fit of an individual with the lifestyle of an entrepreneur. It can also be used to assess their strengths and weaknesses in terms of the consistency between the attitude components (affect, cognitive and conative) in the individual's entrepreneurial mindset. Finally, it may also be the start of a theory-based assessment program for entrepreneurship programs at all levels of education—assessment that can go beyond knowledge and skill-based testing to demonstrate a true impact on attitude-based mindset.

References

Ajzen, I. (1982) On behaving in accordance with one's attitudes. In M.P. Zanna, E.T. Higgins, and C.P. Herman (Ed.), *Consistency in Social Behavior: The Ontario Symposium 2* (pp. 3-15). Hillsdale, NJ: Erlbaum.

Allport, G.W. (Ed.) (1935) *Attitudes*. Worcester, MA: Clark University.

Breckler, S.J. (1983) Validation of affect, behavior, and cognition as distinct components of attitude *Dissertation Abstracts International 44(11B)*, 3569.

Breckler, S.J. (1984) Empirical validation of affect, behavior, and cognition as distinct components of attitude. *Journal of Personality and Social Psychology*, 47, 1191-1205.

Carlson, S.D. (1985) Consistency of attitude components: A new proposal for an old problem. *Dissertation Abstracts International*, 46(09B), 3261.

Carlson, S.D. (1994) *Entrepreneurship education for the multiple cognitive-developmental levels of third graders: Differential impacts of three experience-based programs*. Los Angeles: University of California.

Carsrud, A.L., and Johnson, R.W. (1987) Entrepreneurship: A Behavioral Science Perspective. *Entrepreneurship and Regional Development: An International Journal*, 1(1), 21-31.

Chapman, S., McPhee, P., and Proudman, B. (1995) What is Experiential Education. In M.S.K. Warren, J.S. Hunt, Jr. (Ed.), *The Theory of Experiential Education*. Dubuque, Iowa: Kendall/Hunt Publishing Company.

Crosby, A. (1995) A Critical Look: The Philosophical Foundations of Experiential Education. In M.S.K. Warren, J.S. Hunt, Jr. (Ed.), *The Theory of Experiential Education*. Dubuque, Iowa: Kendall/Hunt Publishing Company.

Dutton, J.E., and Stumpf, S.A. (1991) Using behavioral simulations to study strategic processes. *Simulation & Gaming*, 22, 149-173

Endres, A.M., and Woods, C.R. (2006) Modern theories of entrepreneurial behavior: A comparison and appraisal. *Small Business Economics*, 26(2), 189-200.

Gartner, W.B., and Carter, N. (2003) Entrepreneurial Behavior and Firm Organizing Processes. In D.B.A. Zoltan J. Acs (Ed.), *Handbook of entrepreneurial research: An interdisciplinary survey and*

introduction (Vol. 1, pp. 195-221): International Handbook Series on Entrepreneurship.

Gibb, A. (2002) In pursuit of a new 'enterprise' and 'entrepreneurship' paradigm for learning creative destruction, new values, new ways of doing things and new combination of knowledge. *International Journal of Management Reviews*, 4(3), 233-269.

Gibson, S.G., Walker, P., Harris, M.L., and Harris, D. (2010) *Investigating the Entrepreneurial Attitudes of African Americans: a study of young adults* Presented at the 2010 Small Business Institute National Conference Proceedings

Harris, M.L., Gibson, S.G., and Taylor, S.R. (2007/2008) Examining the impact of small business institute participation on entrepreneurial attitudes *Journal of Small Business Strategy*, 18(2), 57-75.

Harris, M.L., Gibson, S.G., Wang, C., Barber III, D., and Orazov, S.A. (2009) *Examining the Entrepreneurial Attitudes of College Students: a multi-country perspective* Presented at the USASBE 2009 Conference Anaheim, California.

Huefner, J. (1991) *Affect-cognition-conation consistency and the attitude-behavior relationship*. (Vol. PH.D.) Provo, Utah: Brigham Young University.

Joplin, L. (1995) On defining experiential education. In M.S.K. Warren, J.S. Hunt, Jr. (Ed.), *The Theory of Experiential Education*. Dubuque, Iowa: Kendall/Hunt Publishing Company.

Kasselman, B.H., De Beer, J.J., and Vermeulen, L.P. (2002) 'Personality attributes of successful franchisees in the fast foods sector in South Africa'. *South African Journal of Economic and Management Sciences*, 5(1), 154-179.

Kassicieh, S.K., Radosevich, R., and Umbarger, J. (1996) A Comparative Study of Entrepreneurship Incidence among Inventors in National Laboratories. *Entrepreneurship: Theory and Practice*, 20(3), 33-49.

Katz, D., and Stotland, E. (1959) A preliminary statement to a theory of attitude structure and change. In S. Koch (Ed.), *Psychology: A study of a science* (Vol. 3, pp. 423-475). New York: The Free Press.

Keys, B., and Wolfe, J. (1990) The role of management games and simulations in education research. *Journal of Management Education*, 16, 307-336.

Kothandapani, V. (1971) Validation of feeling, belief, and intention to act as three components of attitude and their contribution to prediction of contraceptive behavior. *Journal of Personality and Social Psychology*, 19, 321-333

Kristensen, K., Pedersen, D., and Williams, R.N. (2001) Profiling religious maturity: The relationship of religious attitude components to religious orientations. *Journal for the Scientific Study of Religion*, 40(1), 75-86.

Mitchell, T.R., and James, L.R. (1989) Conclusions and future directions: Theory Development Forum, Situational versus dispositional factors: Competing explanations of behavior. *Academy of Management Review: Theory Development Forum, Situational versus dispositional factors: Competing explanations of behavior*. 14(3).

Ostrom, T.M. (1969) The relationship between the affective, behavioral, and cognitive components of attitude. *Journal of Experimental Social Psychology*, 5, 12-30.

Rasheed, H.S., and Rasheed, B.Y. (2003) Developing entrepreneurial characteristics in minority Youth: The effects of education and enterprise experience. *International Research in the Business Disciplines*, 4, 261-277.

Robinson, P.B. (1987) *Prediction of Entrepreneurship Based on an Attitude Consistency Model*. Unpublished Doctoral Dissertation, Brigham Young University, Provo.

Robinson, P.B. (1996) The Minefield Exercise: "The Challenge" in entrepreneurship education. *Simulation and Gaming*, 27(3), 350-365.

Robinson, P.B. and Malach, S. (2004) Multi-disciplinary entrepreneurship clinic: experiential education in theory and practice. *Journal of Small Business and Entrepreneurship*, 17(4), 317- 332

Robinson, P.B. and Malach, S. (2007) Multi-Disciplinary Entrepreneurship Clinic: Experiential Education in Theory and Practice. *Handbook of Research in Entrepreneurship Education*,

Volume 1. Alain Fayolle (Ed.) Edward Elgar Publishing Limited, Cheltenham, UK

Robinson, P.B., and Shaver, K.G. (1995) Metatheory and Entrepreneurship Research. In J. A. Katz and S. R. A. Brockhaus (Eds.), *Advances in Entrepreneurship, Firm Emergence* (Vol. 2, pp. 97-120). London, England: JAI Press LTD.

Robinson, P.B., Stimpson, D.V., Huffner, J.C., and Hunt, H.K. (1991) An attitude approach to the prediction of entrepreneurship. [Empirical Research]. *Entrepreneurship: Theory and Practice*, 15(4), 13-31.

Robinson, P.B., Ahmed, Z.U., Dana, L.P., Latfullin, G.R., and Smirnova, V. (2000) Toward entrepreneurship and innovation in Russia. *International Journal of Entrepreneurship and Innovative Management*, 1(2), 230-240.

Rosenberg, M.J., and Hovland, C.I. (1960) Cognitive, Affective, and Behavioral Components of Attitudes. In M.J. Rosenberg, C.I. Hovland, W.J. McGuire, R.P. Abelson and J.W. Brehm (Eds.), *Attitude Organization and Change: An Analysis of Consistency among Attitude Components*. New Haven, CT: Yale University.

Ross, R.B., and Westgren, R.E. (2006) Economic returns to entrepreneurial behavior. *Journal of Agricultural and Applied Economics*, 38(2), 403-420.

Shane, S., and Venkataraman, S. (2000) The promise of entrepreneurship as a field of research. *Academy of Management Review*, 25, 217-226.

Shariff, M.N.M., and Saud, M.B. (2009) An attitude approach to the prediction of entrepreneurship on students an institution of higher learning in Malaysia. *International Journal of Business Management*, 4(4), 129-135.

Shaver, K.G. (1987) *Principles of Social Psychology* (3rd. ed.). Cambridge, MA: Winthrop.

Shepherd, D.A., and Evans, D. (2002) Self-employment as a career choice: attitudes, entrepreneurial intentions, and utility maximization. *Entrepreneurship: Theory and Practice*, 26 (March).

Souitaris, V., Zerbinati, S., and Al-Laham, A. (2007) Do entrepreneurship programmes raise entrepreneurial intention of science and engineering students? The effect of learning, inspiration and resources. *Journal of Business Venturing* 22(4), 566-591.

Specht, L.B., and Sandlin, P.K. (1991) The differential effects of experiential learning activities and traditional lecture classes in accounting. *Simulation & Gaming*, 22(196-210), 196.

Tam, H. (2009) *How and to what extent does entrepreneurship education make students more entrepreneurial? A California case of the Technology Management Program*. Santa Barbara: University of California, Santa Barbara.

Tam, H., Hansen, G., Blomstrom, S., and Robinson, P.B. (2009, June 14-17) *Entrepreneurship Program Assessment by Student Outcome*. Presented at the Proceedings of the American Society for Engineering Education 116th Annual Conference & Exposition, Austin, TX.

Tan, W.L., Long, W.A., and Robinson, P.B. (1996) Entrepreneurship attitude orientation and the intention to start a business. *Journal of Small Business & Entrepreneurship*, 13(4), 50-61.

Thatcher, D.C. (1990) Promoting learning through games and simulations. *Simulation & Gaming*, 21, 262-273.

Van Wyk, R., Boshoff, A.B., and Bester, C.L. (2003) 'Entrepreneurial attitudes : what are their sources? *South African Journal of Economic and Management Sciences*, 6(1), 1-24.

Walstad, W.B., and Kourilsky, M.L. (1998) Entrepreneurial attitudes and knowledge of black youth. *Entrepreneurship: Theory and Practice*, 23(2), 2-18.

The Weakening of Tenure and Post-Tenure Review: An Issue Analysis

John Hill

Salt Lake Community College

Abstract

Tenure has come under increasing attack in American higher education. While some may deny the presence of an all-out attack, few can deny a trend toward weakening of the power or significance of tenure, coupled with an overall decrease in the prevalence of tenure. Great Britain has already abolished tenure, and the argument could be made that strategies such as the increasing post-tenure review are simply a more stealthy approach to tenure abolishment in the United States. This author analyzes the legal, ethical, and practical aspects of these issues, and presents a reasonable approach toward amelioration of the issue of weakening tenure.

Introduction

Tenure evolved in the early 1900's over concerns in academia regarding the academic freedom necessary for faculty to teach and research without fear of reprisals. In 1940, following a series of joint

conferences begun in 1934, representatives of the American Association of University Professors (AAUP) and the Association of American Colleges (now the Association of American Colleges and Universities) agreed upon a restatement of principles set forth in the 1925 Conference Statement on Academic Freedom and Tenure. This restatement is known to the profession as the 1940 Statement of Principles on Academic Freedom and Tenure (AAUP, 2005a):

Institutions of higher education are conducted for the common good and not to further the interest of either the individual teacher or the institution as a whole. The common good depends upon the free search for truth and its free exposition. *(1940 Statement of Principles on Academic Freedom and Tenure)*

Tenure has essentially become a civil-service style protection for faculty careers in academia. College and university faculty contend that tenure is an absolute necessity and the linchpin of academic freedom (Poskanzer, 2002, p. 148). Some institutions and administrators contend that tenure is an antiquated system that imposes inflexible burdens on the academy, and may foster—or even encourage—mediocrity. An analysis over the past several years has indicated a climate in which the tenure system is weakening. Data show that over a 20-year period starting in 1975, the number of full-time non-tenure-track faculty nearly doubled, while the number of full-time faculty on tenure track dropped by 12% (Poskanzer, 2002, p. 156). If scholars, and the AAUP, agree that tenure and academic freedom are inextricably linked, then it can be argued that post-tenure review and the weakening of tenure are similarly connected.

Legal Aspects

Tenure certainly is a unique and amazing entity. No other profession, except federal judgeships, awards tenure (Nova Southeastern University, 2005). Tenure provides faculty some powerful legal contours, including property interests, liberty interests, and contract principles, as well as procedural rights (Cann, 2005, pp. 344-345; Olivas, 1997, p. 318).

The traditional and historic protections provided under the tenure system took on more formalized and legally defined authority under such landmark cases as *Perry v. Sindermann* [408 U.S. 593 (1972)] and *Board of Regents v. Roth* [408 U.S. 564 (1972)] (Olivas, 1997, pp. 320-

327). These two cases provided a legal guideline for the property and liberty rights of faculty (Poskanzer, 2002, pp. 240-241).

Perhaps the most significant source of legal basis regarding tenure has been that provided by the AAUP. Founded in 1915, the AAUP has been the foremost advocate of tenure and academic freedom.

In 1900 when noted economist Edward Ross lost his job at Stanford University because Mrs. Leland Stanford didn't like his views on immigrant labor and railroad monopolies, other professors were watching. The incident stuck in the mind of Arthur O. Lovejoy, philosopher at Johns Hopkins. When he and John Dewey organized a meeting in 1915 to form an organization to ensure academic freedom for faculty members, the AAUP was born. "Academic freedom" was a new idea then.

More than eighty years later the AAUP is still addressing the kinds of abuse that spurred Lovejoy and Dewey to organize the Association. Academia has changed a lot since 1915, but there are still people who want to control what professors teach and write. Thanks to the AAUP, academic freedom is recognized as the fundamental principle of our profession. Despite this acceptance, academic freedom remains vulnerable. The attacks are more subtle in some cases, but the response must always be decisive.

AAUP remains the leading organization primarily dedicated to protecting the academic freedom of professors. Faculty members turn to AAUP for assistance in the thousands each year. Some of these faculty members are well-known figures with resources and support. Most, however, are ordinary faculty members who need guidance in responding to troublesome or threatening professional attacks.

Through AAUP, faculty determine the principles of our profession and the procedures by which to protect them. When the AAUP speaks, it is the voice of the profession. (AAUP, 2004).

The AAUP has managed to remain influential and at the forefront of tenure advocacy through a variety of means. The AAUP has backed faculty legally and financially, by filing motions and briefs on cases in which it realized concerns and interests relating to the ramifications of

the outcome of the cases, and through its established principles. Many colleges and universities have adopted established AAUP principles (and formal statements) as part of organized faculty labor contracts. This has provided widespread recognition of same in a vast array of case law. As such, the AAUP reigns as the benchmark on the legal aspects of this issue.

Ethical Aspects

This author firmly believes that the previously noted comparison of federal judgeships and faculty regarding tenure is just as prophetic as it is profound. The innate balance of the American legal system and its wonderful and amazing history of litigation, which have provided incredible fairness and foresight, speaks volumes about the tenure provided to judges. Could these judges have acted so prudently, fairly, and boldly given the politically charged climate surrounding much of the litigation?

Similarly, reflecting on the wonderful and amazing history of research and teaching displayed by American colleges and universities—would this history be markedly different were it not for tenure and academic freedom? This author proposes that it would be remarkably different, and detrimentally so. Educators need freedom to grow professionally (Glickman et al. 2005, p. 351). If our colleges and universities are to fill the great tasks we set for them, the college and university faculty who will take the lead in accomplishing these tasks will require enormous intellectual and didactic latitude—what is commonly called *academic freedom* (Poskanzer, 2002, p. 2).

Still, this author acknowledges that there have been abuses of the tenure system. There are cases in which the shield of tenure has been used as a sword by unethical or unscrupulous faculty. Fortunately, these cases are rare. Hamilton (2002) highlights some significant ethical dilemmas regarding tenure and academic freedom, noting that higher education has historically accepted some degree of misbehavior or incompetence among a subset of tenured professors because the degree of vigilance necessary to prevent it would generate greater costs than benefits (p. 27).

Caution must be taken here not to punish all faculty for the transgressions of a very few misguided colleagues. Faculty sometimes find it necessary to remind administrators that the institution's ultimate strength and distinction derives from the quality of its faculty. They are right to stress this point. More than any other factor, it is the presence of an outstanding faculty that enables a college or university to attract

the most talented students, and to recruit the new faculty that are crucial to its future (Poskanzer, 2002, p. 2).

The AAUP, faculty in general, and many scholars believe that—as a result of the aforementioned influences—tenure as we know it is being weakened. Indeed, this fact is inherent in the position of these stakeholders and scholars on post-tenure review. Post-tenure review has emerged as a contemporary double-edged sword. It is seen by some as a means of bolstering tenure, and by others as a means of diminishing tenure.

Practical Aspects

Whichever side of the issue one may stand on, faculty or administration/institution, there has to be general agreement that tenure is weakening, if not under direct attack. Great Britain's Education Reform Act (1988) called for new governance and accountability measures, no small aspect of which abolished tenure (Duke, 2004, p. 20). British academic staff had traditionally enjoyed a security of tenure that was "second to none" (Perkin, 1969, p. 85). Court (1998) laments that the Education Reform Act was nothing less than a death knell for academic tenure in the "old" universities:

... (i.e., not including the institutions which have become universities since 1992) of the UK, and perhaps raised more questions about academic freedom than it answered. The Act established the University Commissioners, whose remit included making sure that each university had: "an appropriate body, or any delegate of such a body, to dismiss any member of the academic staff by reason of redundancy"; the power to dismiss any member of academic staff for good cause; disciplinary procedures for dealing with complaints made against members of academic staff; and procedures for hearing and determining appeals by dismissed academic staff. The Act said a member of academic staff was redundant if the university had ceased, or intended to cease, "the activity for the purposes of which he was appointed", or if the demand for work of a particular kind had ceased or diminished or re expected to cease or diminish. The Act empowered the University Commissioners to modify the statutes of any university "as they consider necessary or expedient". Academic staff appointed before November 20, 1987 were exempt from the Act; staff appointed on or after November 20, 1987, or promoted on or after that date were not exempt. All universities existing be-

fore 1992 have now amended their statutes to include the new law about academic redundancy. Institutions which became universities after 1992, principally the former polytechnics, were not covered by the provisions of the Act; their academic staff did not have tenure (Court, 1).

Higher education in America has taken notice of what occurred in Great Britain. This author purports that the American version of England's reform may be the increase of post-tenure review. Hamilton (2002) supports this position, indicating that in the last 15 years, as a result of growing public pressure for accountability, there has been significant movement toward some form of post-tenure review (p. 26), specifically:

...thirty seven states either have adopted system-wide post-tenure policies, implemented them in selected state institutions or are considering such policies, and several regional accrediting bodies now require institutions to implement post-tenure review. A recent Harvard study of 217 institutions found that 46 percent of the 192 institutions that grant tenure have post-tenure review (Hamilton, 27).

A larger 1996 study, involving 680 colleges and universities, found that 61% had post-tenure review policies in place and another nine percent were considering imposing such a requirement (Poskanzer, 2002, pp. 202-203). The AAUP subsequently published a policy statement on post-tenure review conceding that if post-tenure reviews must occur, the faculty should take the lead in crafting and administering them (p. 203).

The AAUP obviously believes that if the growing post-tenure paradigm is upon us, then what better entity to have a say in it than the faculty? If not, by default the institutions and administrators will take the initiative on post-tenure review policies. Lamentably, colleges and universities, like many American employers, have a poor record of treatment, in many cases, of their employees. Indeed, in pouring over Olivas' (1997) casebook (*The Law and Higher Education: Cases and Materials on Colleges in Court*), one cannot help but notice that there is a recurrent theme of ulterior motivation embedded in the fact-patterns of the cases—in layman's terms, a "story behind the story."

Frequently, the decisions display the judge's excellent insight in muddling through the smokescreen of motive. For example, in cases where financial exigencies are cited as a cause for termination of a ten-

ured employee, mentioned specifically is the concern that a purported emergency is demonstrably bona fide (Poskanzer, 2003, p. 226).

Pratt (2005) offers a good example of just how capricious review processes can be. What if the reviewed faculty member is found competent overall, but at odds with something as arbitrary and elusive as personal teaching philosophy? He notes that, increasingly, college and university faculty are asked to articulate their personal philosophies of teaching when they are reviewed for reappointment, tenure, or promotion. Although many institutions use these statements of teaching philosophy to good and fair purpose, other institutions offer false promises, making the statements more of a box than a ladder (Pratt, p. 33). How does a faculty member defend his personal teaching philosophy if denied tenure because of same?

The practicality of such is impractical, according to this author. Moreover, the “bogeyman” concern that tenure promotes mediocrity or even misconduct has no factual basis:

Dismissals of tenured faculty for incompetence or unethical conduct have been rare. In the period 1970-1990, the AAUP reported 1,589 dismissals. Eighty-four percent (1,334) were for financial exigency, retrenchment, or restructuring; 6.5 percent (104) were civil liberties cases involving freedom of speech or political or religious activity; 4.0 percent (63) were dismissed for union or faculty senate organizational activity, criticism of the administration, or employment grievances; and the remaining 5.5 percent (87) of the cases involved miscellaneous causes, including incompetence or unethical conduct (Hamilton, 2002, p. 28).

So, if the vast majority of dismissals, 84%, are for financial exigency, retrenchment, or restructuring, then why is tenure under such contemporary scrutiny? In accordance with the “sound-bite” paradigm in America, this author believes that the “horror stories” may be distorting the collective perception on the matter. An example is the infamous Ward Churchill case, erupting furiously out of Colorado, in which Churchill was dubbed “The 9/11 Professor.”

Churchill has been excoriated by the conservative media for his written remarks in which he described victims of the attacks on September 11, 2001, as “little (Adolf) Eichmanns” (AAUP, 2005c). The resulting fallout has led to a polarization of a small cadre of Churchill supporters opposite an overwhelming array of citizens and powerful government and media representatives calling for Churchill’s removal.

Subsequently, officials in Colorado instituted the process that led to the termination of Churchill.¹

Because Churchill was a tenured professor, the case has all the elements inherent in an analysis of the power of tenure. It revolves around tenure's principal component, academic freedom. This author is conservative, and moreover, lost 10 personal friends and acquaintances (over half of whom were police officers) in the collapse of the World Trade Center in New York City. Still, in the name of tenure and academic freedom, this author believes that Professor Churchill should not be removed from his professorship.

Could Churchill have used better words in his treatise? Yes, as the connotation to Eichmann and Nazism is more caustic and polarizing in nature than collegial and academic. As such, perhaps discipline lesser than dismissal seems to be in order. Indeed, these contingencies have been previously addressed by the profession:

...college and university teachers are citizens, members of a learned profession, and officers of an educational institution. When they speak or write as citizens, they should be free from institutional citizenship or discipline, but their special position in the community imposes special obligations. As scholars and educational officers, they should remember that the public may judge their profession and their institution by their utterances. Hence, they should at all times be accurate, should exercise appropriate restraint, should show respect for the opinions of others, and should make every effort to indicate that they are not speaking for the institution – 1915 AAUP General Declaration of Principles (AAUP, 2005b) (Hamilton, 2002, p. 33).

Conclusion

In conclusion, this author believes that a more reasoned, common-sense, measured, practical, and non-knee-jerk approach must be taken when it comes to tenure and post-tenure review. One need not have a

¹ Churchill was fired in July of 2007 from his tenured position teaching ethnic studies at the University of Colorado at Boulder for multiple instances of research misconduct, including plagiarism and misrepresenting the work of other scholars—charges he has denied. Several faculty panels reached the conclusion that Churchill had committed research misconduct, but they investigated him in the wake of a furor over his controversial comments in which he had labeled some of the victims of 9/11 as "little Eichmanns." (Jaschik, 2007)

crystal ball to predict that assaults on academic freedom will continue unabated (Bowen, 2005, p. 88). This author sees tenure as not unlike the abortion issue. To do away with it is to create a remedy worse than the cause, with tragedy pouring into the void.

Post-tenure review seems to diminish the very principle of tenure itself. One innovative and practical approach was that of Richard Chait (1998) who suggested that post-tenure review should be for entire departments, and not the individual faculty (p. 15). This would go a long way toward eliminating personal “witch hunts” and ulterior motives, while building a sense of team spirit among department faculty. Or, as Chait notes, reinforce the faculty’s collective responsibility for quality (p. 20). Discrepancies found at a departmental level could then be analyzed more closely. This idea shows more respect for the tenure system, while seeming to be less vulnerable to abuse by administrators and institutions.

References

American Association of University Professors—AAUP (2005a). 1940 Statement of Principles on Academic Freedom and Tenure. Retrieved February 10, 2005 from the World Wide Web: <http://www.aaup.org/statements/Redbook/1940stat.htm>

American Association of University Professors—AAUP (2005b). 1915 General Declaration of Principles. Retrieved February 11, 2005 from the World Wide Web: <http://www.aaup.org/statements/Redbook/1915stat.htm>

American Association of University Professors—AAUP (2005c). Statement on Professor Ward Churchill Controversy. Retrieved February 15, 2005 from the World Wide Web: <http://www.aaup.org/newsroom/Newsitems/churchill.htm>

American Association of University Professors—AAUP (2004). About the AAUP. Retrieved February 12, 2005 from the World Wide Web: <http://www.aaup.org/aboutaaup/HIST.htm>

Bowen, R. W. (2005). Funding academic freedom. *Academe: Bulletin of the American Association of University Professors*, 91(1), 88.

Cann, S. J. (2006). *Administrative law* (4th Ed.). Thousand Oaks, CA: SAGE Publications.

Chait, R. (1998). Ideas in incubation: Three possible modifications to traditional tenure practices. AAHE new pathways working paper series, No. 9. Washington, DC: American Association for Higher Education.

Court, S. (1998). *Academic tenure and employment in the U.K.* Retrieved February 13, 2005 from the World Wide Web: <http://www.csus.edu/psa/court.html>

Duke, D. (2004). *The challenges of educational change*. Boston, MA: Pearson/Allyn and Bacon.

Glickman, C. D., Gordon, S. P., and Ross-Gordon, J. M. (2005). *The basic guide to supervision and instructional leadership*. Boston, MA: Allyn and Bacon.

Hamilton, N. W. (2002). *Academic ethics: Problems and Materials on professional conduct and shared governance*. Westport, CT: American Council on Education/Praeger Publishers.

Jaschik, S. (2007, December 31) A Moderate MLA. *Inside Higher Ed*. Retrieved January 2, 2008 from the World Wide Web: <http://insidehighered.com/news/2007/12/30/mla>

Nova Southeastern University (2005). *On-line study guide (and module notes) EHD/LDR 9820: Legal and ethical issues in higher education leadership* (Drs. Aselson and Wolfson). Ft. Lauderdale, FL: Nova Southeastern University FSEHS.

Olivas, M. A. (1997). *The law and higher education: Cases and materials on colleges in court* (2nd Ed.). Durham, North Carolina: Carolina Academic Press.

Perkin, H. (1969). *Key profession: The history of the association of university teachers*. London, England: Routledge & Kegan Paul.

Poskanzer, S. G. (2002). *Higher education law: The faculty*. Baltimore, MD: Johns Hopkins University Press.

Pratt, D. D. (2005). Personal philosophy of teaching: A false promise? *Academe: Bulletin of the American Association of University Professors*, 91(1), 33.

Westminster College's Master of Arts in Teaching and YouthCity: An Effective After-School Partnership

Joyce Sibbett, Shamby Polychronis, and Elizabeth Robinson Rich

Westminster College

Abstract

After-school programs hold promise for providing a safe and supportive environment for preteens and teens. In an effort to increase awareness of the importance of after-school programs, which includes effective parent involvement, Westminster College School of Education has partnered with YouthCity, an after-school program in Salt Lake City. Westminster pre-service teachers do fieldwork that includes observation, lesson planning and implementation, and parent interviews at the four YouthCity locations in Salt Lake City. In the past two years, the outcome for Westminster students has been an awareness and appreciation for the importance of creating safe havens for preteens and teens to develop self confidence, respectful relationships, and varied interpersonal and academic skills that benefit them in school and beyond. YouthCity students have also benefitted from the lessons and involvement of Westminster students.

Benefits of Quality After-School Programs

According to Bodilly and Beckett (2005), claims of effectiveness of after-school programs include changed attitude toward academic achievement, changed social and health behaviors, and changed social interactions. They associate the following nine factors with quality program provision: clear vision; high expectations and positive social norms; safe and healthy environment; supportive emotional climate; small enrollment; trained personnel; appropriate pedagogy with opportunities for all to engage; integrated family partners; and frequent assessment.

In ways that regular school programs may fall short, after-school programs have the potential to fill the gaps. They can provide tutors and mentors who can promote skill development and reinforce high academic expectations. Hirsch (2005) refers to them as a natural venue for efforts to enhance school reform.

Programs are not only geared toward academic achievement; they may include nonacademic work that enhances personal skills, which may in turn improve academics. For example, students who relate to literary characters tend to be more motivated to read. Activities in music, drama, and art integrate subjects such as mathematics or science. Experience in these broad activities increases self confidence, which carries over to academic achievement. Adolescents need such activities not only for what they provide but for what they prevent. Students without supervision are at greater risk for truancy, stress, poor grades, and substance abuse. They are most likely to be perpetrators or victims of crime in the first few hours after school (Rothstein, 2006).

One study by Martin and colleagues (2007) reported a number of positive academic and behavior changes in a group of 33 youth who attended an after-school program over a period of two years. The after-school program served high-risk teens in an alternative setting. While the study could not specifically distinguish the effects of the after-school program from the alternative setting, the results were impressive. The students' basic skill levels improved at least two grade levels, daily attendance increased, discipline referrals decreased, and none of the students was suspended or expelled.

Both academic and behavioral changes may be affected by connections that students make with their teachers. Youth need adults on whom they can rely and trust (Hirsch, 2005). When these positive supports are in place, after-school programs have the potential to put children on a path to success (Metz, R.; Goldsmith, J.; Arbreton, A., 2008). Based on current research and experience with after-school programs, the Lucile Packard Foundation for Children's Health commissioned the

publication “Putting It All Together: Guiding Principles for Quality After-School Programs Serving Preteens.” The report focuses on six after-school components that may produce positive outcomes for preteens: (1) Focused and Intentional Strategy: Programs have a clear set of goals, target specific skills, and deliberately plan all aspects of the program with a youth development framework in mind; (2) Exposure: Programs are designed to provide preteens with a sufficient number of hours per week over an extended period of time that matches program outcome goals and allow preteens to attend a variety of activities; (3) Supportive Relationships: Programs emphasize positive adult-youth relationships regardless of the curriculum; (4) Family Engagement: Programs strive to include families through various strategies, such as clear communication and a welcoming environment; (5) Cultural Competence: Programs have diverse staff whose backgrounds are reflective of participants and who create practices and policies that make services available to and inclusive of a variety of populations and help participants understand and value a broad range of cultures; and (6) Continuous Program Improvement: Programs strengthen quality through an ongoing and integrated process of targeted staff training, coaching and monitoring, and data collection and analysis.

The advantages of after-school programs have caught the attention of Americans. The After-School Alliance (2009) reports that a poll taken on election eve and election night shows that nearly 89% of voters say that, given the dangers that young people face, after-school programs are important; 76% want the new Congress and their newly elected state and local officials to increase funding for after-school programs.

This need is apparent when Americans realize that adult supervision may deter young people from engaging in activities that harm themselves and society in general. Every weekday afternoon, more than one-third of middle school students are released from school and left without supervision because parents lack good alternatives for care. At this critical age when adolescents may begin to experiment with risky behaviors, 4 million middle school students have no adult supervision (Rinehart, 2008).

YouthCity: An Effective After-School Program

YouthCity (YC) is a comprehensive set of four programs that began in 2000 under the direction of then-Mayor Rocky Anderson. It includes both an after-school and a summer program that were designed to address issues related to the education, prevention, and enrichment of youth aged 9 to 14 years. The programs are strategically

located within four city parks in the heart of Salt Lake City, Utah. The mission of YC is to support the efforts of families, schools, and neighborhoods in helping make Salt Lake City a safe and nurturing environment for children.

One of the foundational components of the YC framework is help develop personal relationships with caring adults. To accomplish this, YC maintains a 12:1 student-to-staff ratio. Staff members receive ongoing training on child development, behavior management, and teaching strategies and are encouraged to share their talents and interests inside the program.

A second critical component is a character education program called the Power of One. This program was designed to help students take personal responsibility for the success of their lives. To achieve this, YC has identified nine character education principles, which are discussed, modeled, and explored through a series of large and small group activities. These principles are service, honesty, integrity, determination, compassion, caring, resiliency, perspective, and respect.

In each program, children of every shape, color, and size meet together and form strong connections and friendships. The programs are purposefully located away from public schools to bring students from various neighborhoods together for a new common experience. Participating youth come from a variety of backgrounds, including children from educated homes and private schools, children receiving special education services, children living at homeless shelters, children with two, three, and four sets of parents, children being raised by foster and grandparents, children who are refugees, children whose parents are incarcerated, children who speak little English, and children who simply live across the street and want to have some fun after school. Each program is a unique blend of the best and brightest Salt Lake City has to offer. One of the unintended consequences of the YC composition is that a child could be a “super nerd” at school but has the opportunity to be a respected leader at YC. If a child can feel accepted, connected, and cared for, learning increases tenfold.

Westminster’s Partnership with Youth City

Westminster College’s School of Education has reached out to partner with YC’s after-school programs as part of their effort to acquaint teacher candidates with a diverse population of students. The goal was to teach Westminster students about the importance of fostering a sense of community, learning about “funds of knowledge” (Gonzales and Moll, 2009) that YouthCity students bring to the after-school

setting and learning the importance of enriched programs for after school.

Westminster Master of Arts (MAT) students visited four YC sites during their first semester (Summer 2009) in small groups of three to five individuals, observing YC programs in action and then teaching a community-building lesson to students. They also interviewed a parent whose child attends the YC program.

Westminster students found that their experience at YC helped them acquire fundamental understandings that impacted their conceptualization of the teaching and learning experience. They recognized connections between students and leaders that emphasized trust and respect. Children enrolled at YC, ages 8 to 15, were able to enjoy a variety of experiences that spread across age levels. Students played games, engaged in learning activities, cared for their environments, and interacted with each other in ways that typical school experiences discourage based upon age demarcations that separate students.

YC students were invested in one another and openly forged friendships regardless of age differences. An attitude of camaraderie and helpfulness was apparent in each of the sites. Every one of the 20 MAT students who observed at YC commented on the ethics of respect and consideration that pervaded the YC sites. One MAT student made the following comment in a reflection on her observations: "As I observed the culture and community of Youth City I was struck by the dynamics. There were children ranging from eight to fifteen years old, and they treat each other as if they were family. They take care of each other. When they play games, they make sure the youngest ones are included. They were especially sensitive to the fact that on more physical games, such as Capture the Flag, the youngest girls were not always 'it.' An older child would step in and take a turn. This and other observations demonstrated an ethic of care that children are developing." Another comment captures a similar tone: "Inclusion and respect are at the core of (Youth City). The 'Power of One' is a major concept that emphasizes how each individual has the power to make a difference in other people's lives and their environment."

YC provides creative freedom for movement and lessons that extend beyond academics. Children write and perform songs; write and produce brief movie clips; and negotiate rules for team play, and then abide by their own rules. In short, these students learn life skills through life activities, and they do it with respect and collaboration.

The driving force behind YC students' success is the comfort students experience with staff members. They know and understand the rules, and they respect staff members' need to uphold the rules. This respect is earned by staff members exhibiting respect toward students,

parents, and each other. They connect with students as individuals, regularly listen to their opinions, and routinely celebrate their accomplishments. Each student knows that he or she will receive public recognition, so competition for negative attention does not typically occur at YC. Staff members communicate with parents or guardians on a regular basis, and families participate in YC on-site events. As a result, YC students recognize that their leaders understand characteristics of their family backgrounds, which seems to add a layer of personal investment that extends beyond the program.

In conclusion, Westminster MAT students had a critically important learning experience at Youth City. They witnessed the importance of a safe haven that reinforces positive identity and respect for others; they experienced firsthand the benefits that children enjoy in a nurturing and supportive environment; and they observed YC's concerted effort to help students gain the confidence and self respect required to become good citizens and successful students. Relationship building was at the core of YC's success, and the positive relationship extended to family members as well as YC participants. Through their experiences at YC, Westminster's students also connected with each other in supportive relationships as they collaborated and reflected on effective practices that facilitate learning in a fun, active, and effective environment.

References

After-School Alliance (2009). *2008 Afterschool year in review: A year of diligence and promise*. Retrieved from <http://www.afterschoolalliance.org/documents/2008YearInReview.pdf>

Bodilly, S. and Beckett, M. (2005). *Making out of school time matter: Evidence for an action agenda*. Santa Monica, CA: RAND Corporation.

Gonzales, N. and Moll, L. (2009). *Theorizing practices in households, communities and practices*. New Jersey: Lawrence Erlbaum Associates, Inc.

Hirsch, B.J. (2005). Competing directions for after-school programs. In B.J. Hirsch (Ed.) *A place to call home: After-school programs for urban youth* (pp. 3-19). Washington, DC: American Psychological Association.

Martin, D., Martin, M., Gibson, S.S., and Wilkins, J. (2007). Increasing prosocial behavior and academic achievement among adolescent African American males. *Adolescence*, 42, 689-698.

Metz, R.A., Goldsmith, J., and Arbreton, A.J.A. (2008). Putting it all together: Guiding principles for quality after-school programs serving preteens. *Philadelphia: Public/Private Ventures*. Retrieved April 15, 2010, from http://www.ppv.org/ppv/publications/assets/234_publication.pdf

Rinehart, J. (2008). The promise and challenge of after-school programs. *Principal*, 88 (1). Retrieved from http://www.naesp.org/resources/1/Principal/2008/S-O_p60.pdf

Rothstein, R. (2006). Reforms that could help narrow the achievement gap. *Policy Perspectives*. Retrieved from http://www.wested.org/online_pubs/pp-06-02.pdf

3-D Numerical Simulations of Liquid Laminar Flow at $Re=1$ over Super-hydrophobic Surfaces with Post Geometries

Abolfazl Amin

Utah Valley University

Abstract

We numerically investigated the influence of post patterned super-hydrophobic surfaces on the drag reduction for liquid flow through microchannels. Hydrophobically coated surfaces exhibiting microscale structures such as ribs/cavities and posts/cavities can significantly reduce the liquid–solid contact. Preventing liquid from entering the cavities increases the fraction of liquid–gas interface, which results in reduced surface friction. Fully developed laminar flow at low Reynolds number is considered here. The effects of cavity fraction (the ratio of cavity area to total surface area) and relative module width (ratio of post/cavity repeating length to the channel hydraulic diameter) on the slip length and on the Darcy friction factor-Reynolds number product, fRe , were explored numerically for the post structured

hydrophobic walls. The cavity fraction and relative module width were allowed to vary from 0.5 to 0.9998 and from 0.01 to 1.5, respectively. In general, as both cavity fraction and relative module width increase, the equivalent frictional resistance decreases. The present results were compared with those for surfaces exhibiting rib/cavity patterns aligned parallel and perpendicular to the flow direction. At high cavity fractions, the post/cavity structuring produces larger relative slip and greater reductions in the frictional resistance than either parallel or perpendicular rib/cavity structures.

Introduction

In micro- and nanoscale applications super-hydrophobic surfaces can provide, if the right conditions are met, reduced friction at liquid–solid interfaces. An ultra- or superhydrophobic surface is a surface that provides a contact angle, θ , greater than 150° for a liquid droplet. Figure 1 illustrates the contact angle exhibited by a droplet on a surface. An example of a super-hydrophobic surface is a hydrophobically coated and carefully structured or patterned surface.

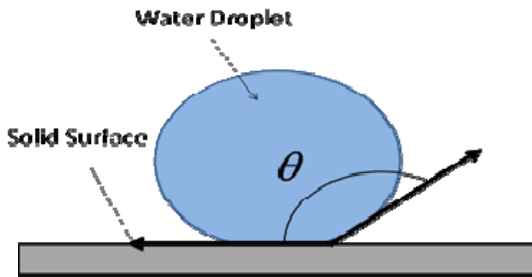

Figure 1. Illustration of the contact angle a liquid droplet attains on a solid surface.

Fluid flow through micro- and nano-channels requires large driving forces. A particular solution for overcoming this difficulty is by reducing the frictional resistance. Recent progress in research and development of microelectromechanical systems, MEMS, and nanoelectromechanical systems, NEMS, has required a greater need for the production of super-hydrophobic surfaces. One way to fabricate a super-hydrophobic surface is by carefully etching away part of the solid surface, creating patterns or structures such as ribs or posts. Subse-

quently, the solid surface is coated with a hydrophobic solution. A review of the literature indicates that the amount of frictional resistance reduction depends on many factors, such as surface geometry, nature of the flow (laminar or turbulent), and whether the liquid enters (wets) the cavities or not.

Intuitively, as the spacing between the created solid surfaces increases, the possibility of liquid entering and wetting the cavities also increases. In order to achieve frictional reduction at the liquid–solid interface, wetting needs to be avoided.

The primary objective of our research was to numerically simulate and examine the effect of various parameters on surface friction in the case of laminar micro-channel flow of liquids over a super-hydrophobic surface exhibiting post-type patterning. The liquid of choice was water at room temperature and numerical simulations were performed for square post geometries.

Results were compared with previously published studies of Davies et al. [2] and Maynes et al. [4]. These analyses enabled us learn under what conditions super-hydrophobic surfaces exhibiting micro-posts produce smaller frictional resistance than surfaces exhibiting micro-rib geometries.

Background

Fluid flow through micro-channels and nano-channels require substantial driving force or pressure drop. In both micro- and macro-channels, this pressure can be reduced greatly by decreasing the frictional resistance. A literature review of previous studies indicate that, in the case of laminar flow at the micro-scale and nano-scale, high surface roughness can potentially reduce frictional resistance at the liquid–solid interface.

Surfaces can be classified as hydrophilic, hydrophobic, or super-hydrophobic, and the contact angle of a water droplet on a surface is used as a measure of hydrophobicity. Figure 2 illustrates hydrophilic (wetted), hydrophobic, and super-hydrophobic surfaces.

A water droplet on a hydrophilic surface will wet the surface and resemble the illustration on the top left in Figure 2, where the angle θ is smaller than 90° . Treating a surface with a hydrophobic coating can reduce the wettability of the surface and change it to a hydrophobic one, as shown in the top right of Figure 2. Carefully patterning a solid surface, or making it rougher, and applying a hydrophobic coating, trapping gas in the cavities, and preventing liquid from entering the cavities can produce a super-hydrophobic surface as presented on the bottom of Figure 2. Studies have shown the larger the contact angle

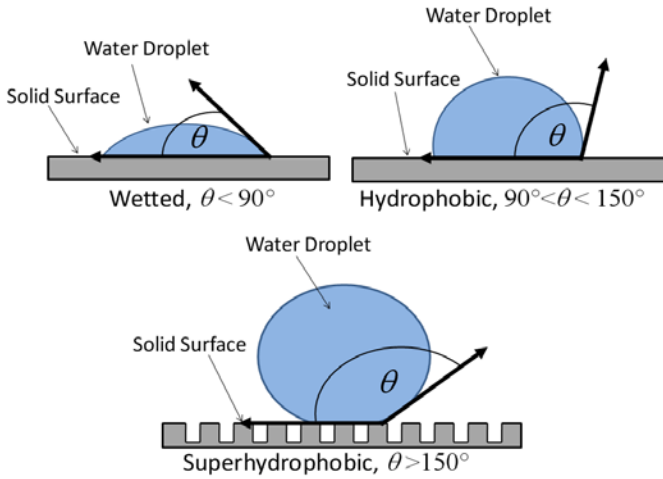

Figure 2. Schematic illustration of the contact angle for hydrophilic (wetted), hydrophobic, and super-hydrophobic liquid–gas–solid surfaces.

(greater than 90°), the greater its hydrophobicity. A scanning electron microscope (SEM) picture of a micro-engineered surface created in the clean room at Brigham Young University is shown in Figure 3(b) [4]. The ribs have a width of $4\ \mu\text{m}$, a depth of $25\ \mu\text{m}$, and a rib spacing of $36\ \mu\text{m}$. A similar SEM picture of a super-hydrophobic surface exhibiting square-post pattern is illustrated in Fig. 3(c). These configurations can be etched directly into the silicon substrate using the deep reactive ion etching (DRIE) process.

Previous work has shown that for the case of continuously flowing liquid through a micro-channel, a super-hydrophobic surface can result in reduced wettability and frictional resistance. By trapping air in cavities and preventing liquid from entering the cavities in a systematic and controlled manner as shown in Figure 3(a), both the frictional resistance and the required pressure drop can be greatly reduced. In this situation, no-slip and slip flow conditions exist at the liquid–solid and liquid–air interfaces, respectively, if wetting of the cavities is avoided. The schematic diagram in Figure 4 also demonstrates qualitative velocity distributions in regions where slip and no-slip conditions prevail. The illustration represents a two-dimensional image of a micro-post or rib and its adjacent cavity with the relevant dimensions labeled. In this figure W_s , W_c , and W represent the solid micro-post width, the cavity width, and their sum, respectively.

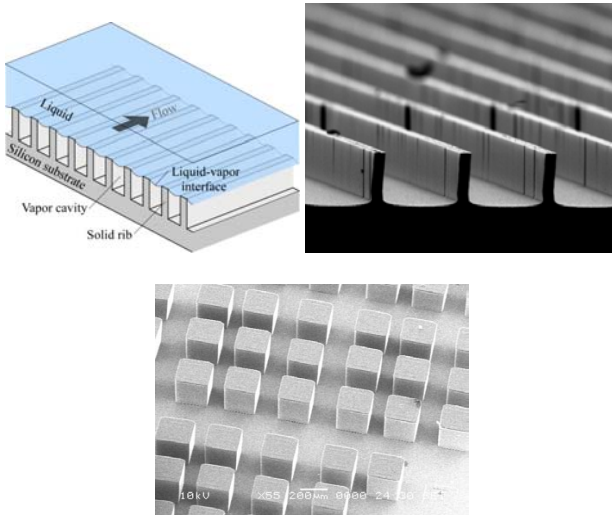

Figure 3. (a) Schematic diagram illustrating a super-hydrophobic surface exhibiting micro-ribs oriented longitudinal to the liquid flow direction, (b) SEM image of a micro-fabricated surface exhibiting rib configuration, (c) SEM image of a micro-fabricated surface exhibiting post configuration.

This illustration is for the non-wetting (super-hydrophobic) scenario where liquid does not enter the cavity. Further, the liquid–vapor interface is assumed to be flat, and the effect of the meniscus is neglected.

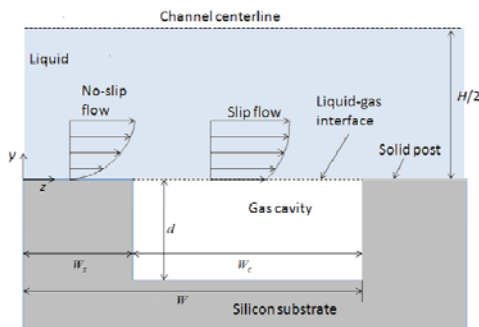

Figure 4. The side view illustration identifies channel regions, dimensions, and notations used in relation to super-hydrophobic post/cavity surfaces. Qualitative velocity distributions are also shown.

Figure 5 is a schematic diagram of a computational domain or a control volume used for the simulations. Because of symmetry and the periodic nature of flow conditions, the illustrated control volume was chosen.

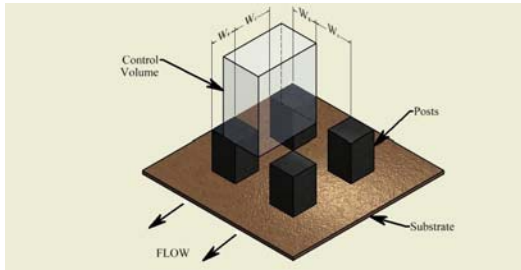

Figure 5. A three-dimensional schematic diagram of the computational domain (or the control volume) over a typical super-hydrophobic surface exhibiting post configuration.

Several relevant variables such as cavity fraction, relative module width, and Reynolds number, which will be used in the following sections, are defined as:

$$F_c = A_c/A \quad (1)$$

$$W_m = W/D_h \quad (2)$$

$$Re = (\bar{U}D_h)/\nu \quad (3)$$

In the above expressions, A_c is the top surface area of the cavity surface, A_p is the top surface area of the post surface, and A is the total surface area ($A_c + A_p$). D_h is the channel hydraulic diameter, $D_h = 2H$, \bar{U} is the average channel velocity, and ν is the liquid kinematic viscosity. The slip length, λ , is another quantity used for analyzing frictional resistance reduction in micro- or macro-channel flow. Macroscopically, there is a specific amount of slip between the liquid and the surface (Figure 6). The slip length is used to characterize the degree of apparent slip that exists, and the greater the slip length the smaller the friction along the interface will be. The slip length, λ , is determined from

an overall macro-level qualitative velocity distribution on a super-hydrophobic surface as shown in Figure 6 [1].

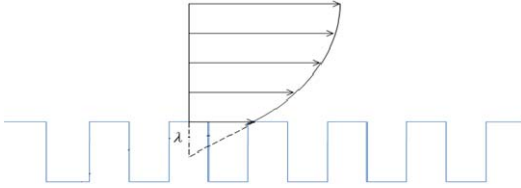

Figure 6. A schematic diagram illustrating representation of the slip length, λ , with respect to the velocity profile.

It is customary to use a nondimensional form of the slip length where it is normalized by the module width, w . It has been shown [2] that the Darcy friction factor, f , and the Reynolds number product $fRe = f(\lambda/w, w_m)$ can also be expressed as:

$$fRe = 8 [1/12 + w_m(\lambda/w)]^{-1} \quad (4)$$

Equation (4) is rearranged to solve for the relative slip length λ/w :

$$\lambda/w = 8/(w_m fRe) - (1/12w_m) \quad (5)$$

Parameters such as fRe and λ/w are frequently used to characterize the frictional resistance reduction in micro-channel flow.

Literature Review

Micro-post designs were studied by Ou et al. [5]. The shear free fractions studied in their micro-post designs ranged from 55.5% to 97%. They obtained about 40% reductions in viscous drag and the required pressure drop.

Salmon et al. [6] performed a three-dimensional numerical simulation of a Newtonian fluid flow through a micro-channel with super-hydrophobic walls. Using finite element analysis, the conservation of mass and momentum equations were solved for the three-dimensional steady flow fully developed incompressible flow with appropriate boundary conditions. The channel was patterned with square posts.

They assumed the liquid–vapor interface was flat, but they considered two scenarios. One was the non-wetting and the other was wetting with liquid intersecting the posts at a distance (d_{wet}) from the top of the posts. They examined effects of post size, post spacing, channel height, and wetting. They discovered that flow enhancement was about 40% compared with that of the smooth, nonpatterned surface channel, and the apparent slip length was about 5.4 μm . Furthermore, increasing post spacing, decreasing post size, and decreasing wetting depth increased flow enhancement.

Experiments performed by Lee et al. [3] produced noteworthy results. A rotating cone rheometer was used to drive the flow over micro-structured surfaces consisting of posts and grates. It was concluded that slip length over super-hydrophobic surfaces increases exponentially with gas fraction and linearly with another important surface parameter, pitch. For the non-wetting case, the slip lengths up to 20 μm were achieved. They were able to obtain effective slip lengths as large as 185 μm carefully delaying the transition from the non-wetting or Cassie state to wetting or Wenzel state.

Ybert et al. [7] used an analytical/numerical approach for determining effective slip length. They analytically obtained scaling laws for effective slip length at the surface for two extreme limits when the solid fraction approaches zero and one. Using the expressions for these two limits, they derived a general scaling law or formula by interpolation of these two limiting case results. They compared the scaling laws with results obtained numerically for three different geometries: grooves, posts, and holes. They also examined the effects of the gas phase and meniscus curvature on slip length for surfaces consisting of posts, ribs, and grate patterns.

The literature reviewed yields the following conclusions for liquid laminar flow in micro-channels: 1) super-hydrophobic surfaces, regardless of the type of the micro-structure used, can reduce the overall frictional resistance; 2) surface roughness increases the hydrophobicity of a surface; 3) as the cavity fraction increases, the frictional resistance decreases; and 4) to reduce frictional resistance wetting needs to be avoided. Another important conclusion is that for the same amount of liquid–solid contact, micro-post geometries should provide greater decrease in frictional resistance or increase in slip length than other types of micro-structures. It is important to realize that fewer studies on micro-posts have been conducted than other types of geometries such as micro-ribs.

Objectives

This study focused on characterizing the fluid flow over micro-post super-hydrophobic surfaces in micro-channels exhibiting laminar flow. The results from the study will lead to a more complete and detailed understanding of the influence that super-hydrophobic surfaces have on drag reduction based on the influencing parameters. The main objectives were as follows:

Examine the effect of F_c on fRe and λ/w at a very low Reynolds number, $Re = 1$, and the range of $0.25 \leq F_c \leq 0.9998$.

Characterize the influence of W_m on fRe and λ/w at $Re = 1$ and the range of $0.01 \leq W_m \leq 1.5$.

Method

The three-dimensional simulations were performed using the commercially available software package Fluent. They included square micro-posts with the following assumptions:

1. Fully developed steady laminar flow
2. Constant liquid water properties at room temperature
3. Flow through two infinite symmetric parallel plates
4. No slip flow over the solid surfaces
5. Shear free flow at the interface of liquid and air over the cavities
6. Idealized flat interface between the liquid and the air cavities

To numerically simulate and examine the characteristics of flow near the super-hydrophobic surfaces exhibiting micro-posts, a typical three-dimensional control volume with appropriate boundary conditions as shown in Figure 7 was used.

With the boundary conditions and assumptions mentioned above, Fluent was used to solve the coupled Navier-Stokes and continuity equations. For a chosen Re , an average velocity and mass flow rate were calculated. With this fixed mass flow rate simulations were performed, and the output value for the pressure gradient, $\Delta p/L$, was used in the following formula to calculate friction factor–Reynolds number product, fRe :

$$fRe = (2D^2_H/\bar{U}\mu)(\Delta p/L) \quad (6)$$

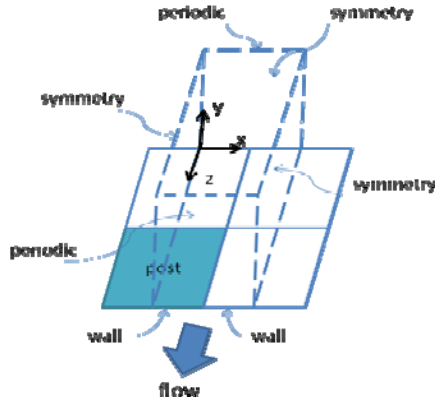

Figure 7. Illustration of the control volume used, with the appropriate boundary conditions, and coordinate system.

Results

Simulations have been performed at 10 different cavity fractions with $W_m = 0.1$ and $Re = 1$. Figure 8 shows the results of fRe versus F_c for these scenarios. Also shown are the previously obtained results of laminar flow in a micro-channel with super-hydrophobic walls for the rib/cavity configuration oriented transverse [2] and parallel [4] to the direction of the flow.

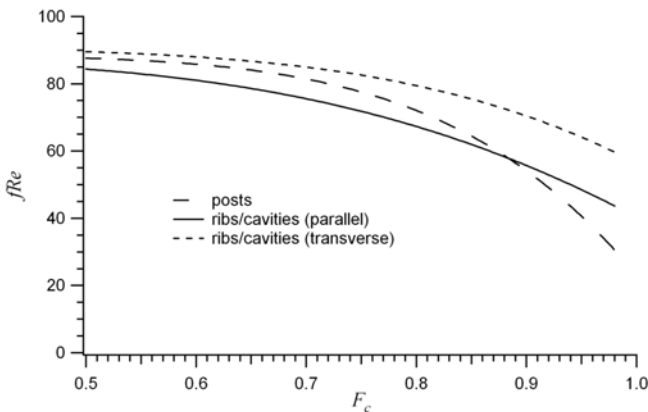

Figure 8. fRe as a function of F_c for post patterning with $W_m=0.1$ and $Re=1$. Also shown are results for flow parallel and perpendicular to ribs.

It can be seen that for all three cases the fRe product decreases as F_c increases. Micro-ribs configured parallel to the flow direction [4] consistently yield smaller values for fRe than for the transverse case [2], with the difference more significant at higher values of F_c . It is very interesting to note that the decrease in fRe for micro-posts is more substantial at high values of cavity fraction than for micro-ribs. This difference seems to begin at about $F_c = 0.78$. The behavior of the fRe result for the micro-posts compared with the other two cases does indeed provide some interesting observation. Up to approximately $F_c = 0.88$, the values of fRe for micro-posts fall between those of parallel and transverse micro-ribs. It appears that for this range of F_c micro-ribs oriented parallel to the flow direction perform better than transverse micro-ribs and micro-posts, but for $F_c > 0.88$ micro-posts outperform micro-ribs and yield greater amount of frictional resistance reduction. Liquid flow through micro-channels requires a great amount of driving force because of very small length scales and very large frictional resistance. In such situations, frictional resistance reduction within the channel becomes desirable. One way to achieve such a reduction in friction is by reducing the friction between the liquid and the surface. The above results demonstrate that by reducing the amount of liquid–solid contact area (*i.e.*, by increasing F_c) the liquid glides over a larger layer of air, which provides smaller amount of friction for the liquid than the solid surface. According to Figure 8, in the opposite scenario the fRe values are larger for smaller values of F_c for all three surface configurations. The implication of this result is logical, because for small values of F_c the liquid–solid contact area, hence, the frictional resistance, is large. In such situations, all three surface configurations provide approximately the same amount of friction to the liquid flow. As seen in Figure 8, the difference between the three patterned surfaces diminishes as F_c decreases.

Shown in Figure 9 are the results obtained for λ/w for the 10 cases considered. As the cavity fraction increases the slip length also increases. This is consistent with the results obtained so far by other research teams on super-hydrophobic surfaces. Since the liquid–vapor interface is assumed to be shear free, the friction is reduced and slipping occurs. In the extreme cases of $F_c = 0$ (all solid or no cavity), the slip length approaches zero, and for $F_c = 1$ (no solid or all vapor) it tends to increase significantly. This is expected and is also similar to results available in the literature for micro-ribs. At high cavity fractions, micro-posts provide larger slip lengths than micro-ribs. Figure 9 illustrates that parallel ribs consistently provide about 20% more slip length than the transverse ribs, but that difference is more significant for posts compared with both rib scenarios. For instance, the slip

length for posts is about 60% higher than the slip length for parallel ribs at $F_c = 0.5$. Increased liquid–air contact area allows a greater amount of slip near the surface of the micro-channel.

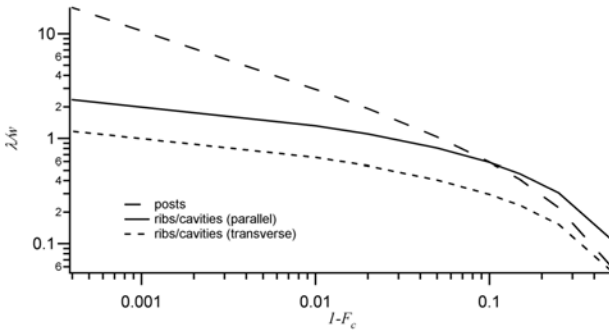

Figure 9. Variation of apparent slip length with cavity fraction for liquid flow through a micro-channel patterned with micro-post features where $W_m = 0.1$ and $Re = 1$.

Figure 10 presents variation of fRe with respect to solid width ratio for longitudinal ribs, transverse ribs, and posts. In classical channel flow, the $fRe = 96$. It can be seen that fRe for all three cases approaches the value of 96 as solid ratio increases. At solid ratio of 1, all three geometries behave exactly the same and provide $fRe = 96$, because there is no cavity and they behave similar to a classical channel. Figure 10 shows more clearly that, for the most part, the posts prove to have smaller values for fRe than the other two configurations.

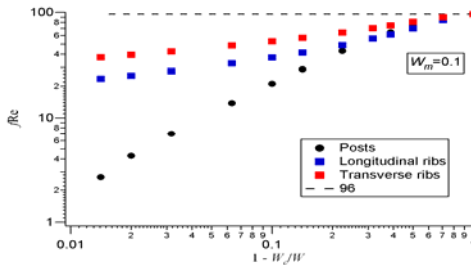

Figure 10. fRe as a function of relative solid width ratio for post patterning at $Re = 1$.

Effect of relative module width on fRe is shown in Figure 11 for three different cavity fractions. As W_m increases, its influence on fRe also increases. This results in decreased values for fRe with increased values of W_m in all three cases. It is good to mention that, according to Figure 11, at high values of F_c this decrease seems to be greater than surfaces with small values of F_c . That implies the larger the amount of the liquid–air contact area the greater the influence of the relative size of the channel height with respect to its width. According to Equation 2, larger or taller channels have smaller relative module width. From the Figure 11 it is important to note that the taller and narrower channels provide more friction to the liquid flow than the shorter and wider channels. That is because for tall channels most of the liquid is far from the surface to be influenced by the type and the geometry of the surface.

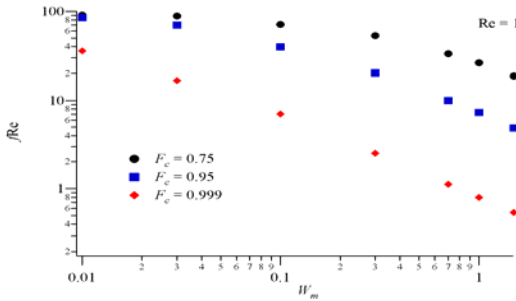

Figure 11. Variation of fRe with respect to W_m at three different cavity fractions for post geometry.

Conclusions

The general contribution of this study was a better understanding of the influence that super-hydrophobic surfaces have on the reduction in frictional resistance for liquid flow through micro-channels at low Reynolds number. A detailed description based on the numerical results showed how the influences of F_c and W_m affect the reduction of surface friction in micro-channels. It was discovered that, regardless of surface geometry, the higher the F_c and W_m the smaller the frictional resistance on super-hydrophobic surfaces. Micro-post patterning provides greater reduction in frictional resistance than transverse micro-rib configuration and at $F_c > 0.88$ also performs better than the parallel micro-rib patterned surface. With respect to the classical channel flow and at the highest F_c considered (0.9998), the transverse and the longi-

tudinal ribs produce 60% and 75% reduction in frictional resistance [2], respectively, whereas the micro-posts reduced friction by 96%. The obtained results are consistent with results found in the literature and the experimental works conducted by Davies et al. [2] and Mayne et al. [4]. Davies et al. [2] also considered the non-flat liquid–gas interface scenario for transverse ribs and concluded that flat liquid–gas interface assumption overestimated the reduction in frictional resistance by about 6%. In our work, the flat liquid–gas interface assumption was made to simplify the governing equations. A future work could consider the existence of meniscus at the liquid–gas interface.

References

1. Chen W, Fadeev AY, Hsieh MC, Oner D, Youngblood J, and McCarthy JT. Ultrahydrophobic and Ultralyophobic Surfaces: Some Comments and Examples. *Langmuir* 15, 3395-3399 (1999).
2. Davies J, Maynes D, Webb B and Woolford B. Laminar flow in a microchannel with superhydrophobic walls exhibiting transverse ribs. *Physics of Fluids* 18: 8: 7110-1-7110-11, 2006.
3. Lee C, Choi CH, and Kim CJ. Structured surfaces for giant liquid slip. *Physical Review Letters* 101: 064501, 2008.
4. Maynes D, Jeffs K, Woolford B, and Webb B. Laminar flow in a microchannel with hydrophobic surface patterned microribs oriented parallel to the flow direction. *Physics of Fluids* 19: 9: 3603-1-3603-12, 2007.
5. Ou J, and Rothstein JP. Direct velocity measurements of the flow past drag-reducing ultra-hydrophobic surfaces, *Physics of Fluids* 17, 103606, (2005).
6. Salamon T, Lee W, Krupenkin T, Hodes M, Kolodner P, Enright R, and Salinger A. Numerical simulation of fluid flow in microchannels with super-hydrophobic walls. *Proceedings of the ASME Heat Transfer Division* 376: 819-829, 2005.

7. Ybert C, Barentin C, Cottin-Bizonne C, Joseph P, and Bocquet L. Achieving large slip with superhydrophobic surfaces: Scaling laws for generic geometries. *Physics of Fluids* 19:12: 3601-1-3601-10, 2007.

A Correlation between Collegiate Baseball Players' Posture and Individual Baseball Statistics

Bret Boyer, Corey Rankin, Leoni Lobendahn, Jason Slack, Mike Bohne

Utah Valley University

Abstract

Postural patterns or deviations may have an effect on athletic performance. In this study, the posture of 28 Utah Valley University baseball players was assessed and correlated with their personal offensive statistics to determine whether there was a correlation between posture and performance. There was no significant relationship identified between overall postural score and position; however, certain postures suggested a relationship to the individual statistics.

Introduction

Postural assessment is commonly used to identify and monitor musculoskeletal norms, anomalies, and/or imbalances (1). Postural assessment has been shown to give insight into biomechanical issues stemming from over-training on some parts of the body and under-training in others (2). Sport-specific and even position-specific training may lead to such imbalances, which in turn may lead to altered (en-

hanced or diminished) performance (3,4) and even injury (5). These postural patterns or deviations may have a correlation between sports and even specific positions that can possibly be revealed in a static posture.

Statement of the Problem

The purpose of this study is to determine whether there is a correlation between static posture and position played and personal performance statistics of Utah Valley University (UVU) baseball players.

Significance of the Study

Static posture is of relative importance in and of itself as it serves as a point of departure for the many dynamic positions assumed by the body and it provides a static method to assess structural (musculoskeletal) balance and symmetry. In addition, "since the number of dynamic postures are endless it is a convenient custom to accept the static standing posture as the individual's basic posture from which all his other postures stem." (2). Although often referred to, the correlation between athletic position and anatomic posture and their potentially associated performance has not been clearly demonstrated in the literature. More research is needed in this area to identify whether there is a correlation and enable us to take appropriate steps to correct posture (imbalances) and reduce injury or enhance performance.

Hypothesis

We hypothesize that there is a relationship between the static posture of UVU baseball players and their relative positions and personal statistics.

Research Methods

The study population consisted of 28 UVU male baseball players. A statistical analysis was used to assess whether there was a correlation between posture, position, and personal statistics. Having completed an informed consent, the subjects completed a demographic survey addressing issues such as age, position played, and years at that position. Each subject then presented to the assessor in short gym shorts that revealed the kneecap for visual inspection. No shoes or shirts were worn so that the subjects' surface anatomy could be visually inspected for landmarks. Subjects were then assigned an identification number to

associate questionnaire with their postural pictures and to protect identity.

Subjects were then posed with toes on a line located 18 inches in front of a 7-foot-tall lined postural grid fixed behind them. Each of the subjects was instructed to breathe deeply and exhale several times to feel relaxed before having his posture assessed. The subjects were told to stand facing the assessors with feet at shoulder width and in a relaxed typical standing posture with their arms to their side. A frontal picture was taken for a future reference for postural assessment by the assessors. Each subject was then asked to rotate one quarter turn to his right with feet at shoulder width and in a relaxed typical standing posture with his arms to his side. A left side picture was taken for a future reference for study by the assessors. This was repeated for posterior view and right-side view pictures. A right side picture will be taken at this point for a future reference for study by the assessors. The 4 pictures for each subject were digitized.

The assessors were trained by a Licensed Physical Therapist to assess and score the subjects' posture using a standardized postural assessment tool. Head tilt, forward head, shoulder level, kyphosis, scoliosis, and lordosis were all assessed. The subjects' posture was scored for each postural item being addressed, and a total postural score was given by each member of the assessment team. When scores differed between assessors they were discussed until a consensus score was determined. The scores were analyzed statistically with the subjects' respective questionnaire.

Several steps were taken to prevent bias. All of the pictures were taken from the same angle, the subjects were not told which postures were being examined, consistent instructions were provided to each subject, consensus was obtained between the assessors with the postural scores, and the assessors were trained to evaluate posture by a Licensed Physical Therapist.

Several steps were used to minimize risks to subjects. Subjects wore gym shorts of their own choosing and no shirts exposing upper body and from mid-thigh down. The subjects were not exposed to elements as they entered the assessment room from the locker room. Each subject's identity was protected by an identification number, and only the assessors associated ID numbers with the subject's picture.

The baseball statistics that were addressed include each of batting average, runs scored, home runs, runs batted in, slugging percentage, strike outs, put outs, attempts, errors, and fielding percentage.

Results

The various postural elements of each subject were compared with the baseball statistics. The following elements were significantly correlated with individual statistics.

—Head Tilt Severity		
Batting Average	R - .617	P - .003
— Forward Head		
Field %	R - .540	P 0 .038
— Kyphosis, Scoliosis, Lordosis		
Wild Pitches	R - .997	P - .049
—Shoulder Level		
Runs Scored	R - .693	P - .003
Hits	R - .725	P - .001
Home Runs	R - .526	P - .036
Runs Batted In	R - .852	P - .001

Discussion

There was no significant relationship identified between overall postural score and position; however, certain postures suggested a relationship to the individual statistics.

Limitations and recommendations

Some of the limitations of this study include having a very small and heterogeneous study population. It was also noted that a more detailed analysis and classification of posture may demonstrate a higher correlation and probability.

Further Research

Having established that there is a relationship between some postural elements and personal statistics, further research needs to be done to determine cause and effect between posture and performance or performance and posture.

Bibliography

Frost, L.H. Individual structural differences in the orthopedic examination. *L. Health & Phys. Ed.*, 9:90-93, 122, 1938.

Sward L. The thoracolumbar spine in young elite athletes. Current concepts on the effects of physical training. *Sports Med* 1992;13:357-64.

Kums T., Vain A. Functional state of the locomotive apparatus and spine posture in rhythmic gymnasts. German Society of Sport Science 6th Annual Congress of the European College of Sport Science; 24-28 July 2001, Koln, Sport und Strauss, 2001.

Dalichau S, Scheele K. Significance of the motoric demands in swimming for spinal profile and postural capacity. German Society of Sport Science 6th Annual Congress of the European College of Sport Science; 24-28 July 2001, Koln, Sport und Strauss, 2001.

Watson AW. Sports injuries in footballers related to defects of posture and body mechanics. *J Sports Med Phys Fitness* 1995;35:289-94

Comparable Study: Running the 1.5-mile Run on a Treadmill Vs. Running the 1.5-mile Run on an Indoor Track

M. Vinson Miner and Jason Slack
Utah Valley University

Abstract

Both quantitative and qualitative components were analyzed to compare running times of 1.5 mile run on an indoor track, to the running times of a 1.5 mile run on a treadmill. Running times were compared to determine if there are any significant time differences or psychological elements between the two methods of running. The research project tested and rendered several runs (both on the treadmill and on the indoor track) over a 7 ½ to 15 week period of time [results; no significant difference between average treadmill time (13:14) and average track time (13:25) were determined]. In addition, the qualitative components were observed, analyzed and documented. Including participants' psychological responses such as motivational, emotional, attitude, likes/dislikes, and preferences, etc were tabulated and compared. In conclusion, no significant difference existed between running

times on a treadmill vs. the indoor track, but psychological preferences varied greatly on the two methods.

Introduction

As part of the requirements for our PES 1097 Fitness for Life class, students are assessed on their cardiovascular fitness by running 1.5 miles. Applying Kenneth H. Cooper Fitness Categories for the 1.5-mile run test, students are able to classify their running time. On certain occasions it has been necessary for us as instructors to have the students run on treadmills because of scheduling conflicts on the running track. This situation has motivated us to investigate, study, and compare, in this initial pilot study, running times of our students on both the indoor track and the treadmill to see whether there are significant differences in their running times. In addition, we were interested and concerned with the psychological elements between the two methods that affect the running times of our students. We were especially interested in psychological responses such as the motivation, emotional state, and attitude of our students about which of the two methods were most preferred. This qualitative component to compare and analyze our students' likes and dislikes, preferences, and feelings about the methods was a major concern for our instructors.

Methods

The Study

Participants (n=70) were enrolled in the Fitness for Life class at Utah Valley University. As part of the class, students are assigned several 1.5-mile runs. Students were asked to sign an informed consent form that explained the study; the study was approved by the Utah Valley University Institutional Review Board. The 1.5-mile runs occur throughout the semester, with the idea that as the students are involved in their cardiovascular training program they will be able to reduce their run times. During the semester, these runs were performed on the Lifestyle 9600 treadmill and on the 1/8-mile indoor track located at Utah Valley University. The speed on the treadmill was self selected, and the student was instructed to adjust the speed to complete the 1.5-mile run as fast as possible. The grade of the treadmill was set to 0 percent. Time was recorded on the treadmill and reported to the researcher. The 1.5-mile run on the track was within a week of the recorded treadmill run. Students were instructed to complete this track run as fast as possible at a self-selected pace. At the completion of the run, the time

was recorded by the researcher, and the data were analyzed using the SPSS statistical software package.

Questionnaire

At the end of the semester, the participants were asked to respond to a questionnaire. They were asked which method of running they preferred and why they preferred their chosen method (reason behind their first response). In addition, the questionnaire asked each participant to discuss (open ended) some of their likes and dislikes and physical or psychological reasons for their preference. Each individual's response was noted and recorded (qualitative component of the research).

Results

Data

Demographic data about the participants was summarized using descriptive statistics: mean age in years (22.7 ± 5.3), mean height in inches (69.1 ± 11.1), mean weight in pounds (163 ± 37.8), mean percent body fat (15.9 ± 7.6), and mean sit-and-reach in inches (15.9 ± 4.23). A Paired T-test was used to compare the difference between the times to complete each run. The average time to complete the run on the treadmill was 794 ± 327 seconds, and the average time to complete the 1.5-mile run on the track was 805 ± 229 seconds. Using the Paired T-test, there was no statistical significance between the times of the two runs with a ($P = 0.693$).

Qualitative Results

Students preferred running on the track to running on the treadmill at a ration of approximately 2 to 1 (46 preferred the track, 21 preferred the treadmill, and 3 expressed no preference). Noted responses to why the participants preferred one method over the other were documented.

Participants' responses for track:

- Running on indoor track feels like it goes by faster.
- View changes and you make progress instead of looking at times.
- On the track counting laps pushes me harder. On the treadmill, I stare at the time and it feels like it goes forever.

- Because I can run at the speed and pace I want to run at.
- I do not like staying in the same place. I am a very active person and it drives me nuts running in place. Also, I constantly look at the clock and it seems like an eternity to finish a run.
- Because I am actually moving and not just running in place.
- It's not as awkward trying to run in such a small space, you can actually move on the track. It helps me feel like I am progressing, and so it pushes me harder to improve.

Participants' responses for treadmill

- I am sure to stay at a steady pace.
- I tend to work better.
- Treadmill makes it so you stay at a constant rate.
- Running on the treadmill is easy because you know exactly where you're at and how fast you're going and everything.
- You can set your speed.
- I feel like I was better able to pace myself and because of the clock on the treadmill I was aware of how fast I was running.
- Never allows me to slow down.
- On the treadmill I was running more because I felt more relaxed.
- Easier, more comfortable, and you can control your speed better.

Discussion

The results demonstrated no significant time difference between track running and treadmill running. Although time varied from participant to participant as the totals were compiled, there was no real time difference noted. The fact that participants preferred track running over treadmill running by a 2 to 1 margin was a unique research element that was discerned by the research. Additional insight was also documented by the research into the qualitative elements and preference of each participant/student.

Conclusion

In summary, the research showed that no matter the mode of running, running times were very similar. Most participants preferred the physical dynamic motion of the track to the stability and stationary motion of the treadmill by a margin of 2 to 1. Additional information

on likes, dislikes, preference, and attitude of each participant varied greatly, but demonstrated unique individual differences. Additional research and number of subjects would enhance the study.

References

Nummela, A, Hamalainen, I, and Rusko, H. (2005). Comparison of maximal anaerobic running tests on a treadmill and track. *Journal of Sports Sciences*, 25(1), 87-96.

Jones, A, and Doust, J. (1996). A 1% treadmill grade most accurately reflects the energetic cost of outdoor running. *Journal of Sports Sciences*, 14, 321-327.

Schlosberg, S. (2003). Outdoor running vs treadmill. *Shape*, 23(1), 140.

Bassett, D., Giese, M., Nagle, F., Ward, A., Raab, D. and Balke, B. (1985). Aerobic requirements of overground versus treadmill running. *Medicine and Science in Sports and Exercise*, 17, 477-481.

Leger, L. and Mercier, D. (1984). Gross energy cost of horizontal treadmill and track running. *Sports Medicine*, 1, 270-277

McMiken, D. and Daniels, J. (1976). Aerobic requirements and maximal aerobic power in treadmill and track running. *Medicine and Science in Sports and Exercise*, 8, 14-17.

Van Ingen Schenau, G.J. (1980). Some fundamental aspects of the biomechanics of overground versus treadmill locomotion. *Medicine and Science in Sports and Exercise*, 12, 257-261.

Pedro Salinas's Theory of Tourism

Andrew Bishop

Brigham Young University

Abstract

Pedro Salinas, a poet from Spain's Generation of 1927, resided in the United States during and after the Spanish Civil War. While teaching in various schools across the country, he attended conferences showcasing his literary criticism, poetry, and playwriting. During this time, he corresponded prolifically with his wife, Margarita Bonmati. On one occasion, he traveled to Los Angeles, California, to attend a literary conference, but along the way he traveled through Missouri, Colorado, and Utah, visiting various landscapes, national parks, and cities. He chronicled his impressions in letters to his wife. These impressions follow a theory of tourism developed by Pedro Salinas. They also follow the idea of intentionality—a phenomenological concept in which appearances have ontological meanings, especially as explained by the French philosopher Maurice Merleau-Ponty. The letters Salinas wrote and the appearances he intended show his focus and soul are his wife. Other impressions recall his lover, Katherine Whitmore. These meditations help Salinas to commune with his beloved. The paper retraces

Salinas's travels through Utah using historical references, contemporary figures, his letters, and a few of his poems.

Introduction

Pedro Salinas exerts a spiritual force in his poetry. His themes deal with the beloved's presence or absence, essences, and the poetic self's perception of scenery. He also deals with spatiality and how the one can commune with another despite long distances. Critics give praise for his talent. Enric Bou and Andrés Soria Olmedo opine that he writes "algunos de los más bellos poemas de amor escritos en español" ("some of the most beautiful love poetry written in Spanish")¹ (1564, footnote 473). Francisco Moreno Gómez describes him as a person that "tiene una visión semiplatónica" ("has a semi-platonic vision") and "estudia [...] la caridad y la claridad" ("studies [...] charity and clarity") (51). Francisco Javier Díez de Revenga admires his "rica personalidad" ("rich personality"), a "madrileño castizo" ("authentic Madrilenian") that loves "al mar y a la luz mediterránea de sus juveniles veranos en Santa Pola" ("the sea and the Mediterranean light of his childhood summers in Santa Pola") (García 87). Díez de Revenga then categorizes him as "uno de los más destacados poetas amorosos españoles de todos los tiempos" ("one of the most prominent Spanish love poets of all time.") (88). R.A. Cardwell sees how Salinas becomes one of the best by incorporating memory in Spanish love poetry:

When we examine the work of [...] Salinas, [...] the positive aspect [...] is immediately apparent. [It is] believed that through remembered experiences the poet can discover a definition of essence, an immanent or transcendent reality for which the existent or phenomenal entity is but an outer shell. (810)

Salinas's ability to find this essence and associate it with a beloved in love poetry has its roots in Romanticism and courtly love. The only modification, according to R. Gullón and Montserrat Escartín Gual, lies in the fact that the poetic self's relationship with the beloved is "controlado por el juego de la inteligencia, pero dependiente de la sensualidad" ("controlled by the game of intelligence, but dependent

¹ All translations, except where indicated, are my own and are only provided in an attempt to help readers who do not know Spanish.

upon sensuality") (Escartín 22). These characteristics emerge in all of the works written by Salinas, including his habitual and almost daily letter writing.

Correspondence, including love letters, forms a part of Salinas's artistic repertoire. Salinas corresponded prolifically with his many friends and family members over his lifetime. In his letters, he writes unpretentiously about his feelings towards people, places, ideas, and art. Readers may get the impression that they are intruding on a private conversation in which they hear only Salinas's side. Salinas never meant to publish or publicize his intimate letters to anyone outside his circle of friends, family, or lover, although he may have suspected they would come to light one day. Thanks to his daughter and son-in-law, as well as to dedicated critics, we have the privilege of knowing a more personal side of Salinas. We can commune with a poetic friend as we learn his likes, dislikes, and points of view. We see how Salinas intends objects in nature deeply. This essay will focus on Salinas's contemplations of nature during a trip to a literary conference in Los Angeles, California. He especially takes notice of landscapes located in Utah. Salinas sees these natural landscapes and records his impressions in writing, painting them with poetic language. He then dedicates all of his observations to his wife, Margarita Bonmatí.

Salinas also had a mistress by the name of Katherine Reding, who later changed her name to Katherine Whitmore, who also received letters and poetic dedications for several years. He met her in his classroom during the 1930s, pursued her as his paramour, and initiated an extramarital affair. The affair lasted until Margarita found out and attempted to commit suicide. Her conscious pricked, Katherine ended physical contact with Salinas and stopped the affair. Nevertheless, they continued to correspond even after the relationship ended. As time went on, Katherine faded away and the communication gap widened. By 1940, Salinas and Margarita were in the U.S. with their family intact. Katherine Whitmore takes second place, indicating that Salinas did not forget her completely.

Salinas developed a heightened sense of observation during his adolescence and young adulthood. He grew up into a responsible and intelligent professor of literature, studying in his hometown of Madrid and in Paris, France. He taught in various places including Spain, France, and Great Britain. When he was not teaching or studying, he wrote letters and poems to Margarita Bonmatí, a young woman living

on the shores near Algiers, Algeria,² at the time. They courted for some years before eventually marrying on December 29, 1915 (Bou 27, footnote 1). Before and during their marriage, Salinas described to Margarita in great detail objects he observed in nature. He dedicated these phenomenological-filled intentions he had to her. He writes about his desire to visit certain places, and in one letter he writes, “Hace muchísimo tiempo que espero una ocasión favorable para ir a América, país por el que siento una vivísima curiosidad y simpatía” (“It has been a long time since I have waited for an occasion to go to America, a country for which I feel a vivacious curiosity and affinity”) (Salinas, *Cartas de viaje* 59).

Salinas’s poetry spans decades. The first set includes titles that whimsically look for the essences of objects (*Presagio*, *Seguro azar*, and *Fábula y signo* or *Presages*, *Certain Chance*, and *Fable and Sign*). When he moves to the U.S., he composes other volumes focusing on the sea surrounding Puerto Rico and other topics, as well as an English translation of some of his poetry with the help of Eleanor L. Turnbull (*El Contemplado*, *Error de cálculo*, *Lost Angel and Other Poems*, and *Todo más claro y otros poemas*). The most popular set of volumes deals with the events of an affair with a beloved. Katherine Reding becomes the catalyst he needs to write about the beloved in *La voz a ti debida* (*The Voice I Owe to You*), *Razón de Amor* (*A Reason for Love*), and *Largo Lamento* (*Long Lament*).³ In other areas, Salinas prolifically produces literary articles, works of theater, and lesser-known translations of other authors.

Salinas became a successful and famous writer and literary professor during his time in Spain before the Spanish Civil War. He even worked as a public official in the education system of the Second Republic. Circumstances changed when the political climate began to sour. Salinas knew his time in Spain was getting shorter. In making his plans, he writes to Katherine the following:

² “Pedro Salinas y su novia, Margarita Bonmatí,” writes Solita Salinas de Marichal, “estuvieron separados durante los tres años de su noviazgo. Ella vivía en Argelia, él en Madrid, y sólo se veían durante un mes al año, en Santa Pola, un pueblecito de Alicante” (“Pedro Salinas and his girlfriend, Margarita Bonmatí, were separated during the three years of their courtship. She was living in Algeria, he in Madrid, and they only saw each other for a month each year, in Santa Pola, a village in Alicante”) (“Presentación” 11).

³ These three collections of poems are now published in one volume with the titles in this order. However, citations in this essay will refer to an individual collection. If readers desire to further their reading or check a particular edition, please refer to entries beginning with either Escartín Gual or Salinas in the Bibliography.

La solución ideal sería irme al extranjero: eso es el modo de romper más natural. ¿Pero dónde y cómo? Lo que me dices de América, alma, es un sueño. ¡Si pudiera ser! Aceptaría cualquier cosa, cualesquiera condiciones, con tal de estar en la misma tierra que tú.

The ideal solution for me would be to leave to other countries: that is the most natural way to *break off*. But where and how? What you have told me about America, my soul, is a dream. If it could only be! I would accept anything, any conditions, so long as I am in the same land as you. (Salinas, *Obras* 483, emphasis in original).

However, fortune smiled on Salinas and he found a way to come to the United States. He got the opportunity while applying for a job located in Massachusetts, and when the Spanish Civil War was about to break out, he accepted the position at Wellesley College and made plans to leave Spain. He became an exile with his wife and children, never to see his land of origin again. Katherine kept her distance from him in the U.S., meeting him rarely. Salinas was left to his contemplation while he traveled for business and pleasure. Travel had always been part of his job description as poet.

The curiosity Salinas has while traveling is insatiable. Wherever he goes he “intends”—a phenomenological verb meaning to observe consciously the essence of an object either real or imagined—each mountain, valley, seashore, or forest in its transcendence. He dedicates visions and poetry to the two women in his life. He writes Margarita a letter stating, “Realmente, vida, la poesía es tuya: así que yo no he hecho más que escribirla” (“In fact, darling, poetry is yours: so I have done nothing but write it down”) (Salinas, *Cartas de amor* 75). He also dedicates poetry to Katherine saying, “Sólo versos escribo. ¿Por qué? Porque se escriben pronto, porque se escriben corriendo, en un momento. Y porque me los manda, me los ordena, una fuerza superior e irresistible, porque vienen de mi Katherine, son de ella, por ella, y para ella, como todo lo de su PEDRO” (“I write only verses. Why? Because they are written soon, they are written running, in a moment. And because a superior and irresistible force commands me, orders me, to write them, because they come from my Katherine, they are of her, by her and for her, like everything from her PEDRO”) (*Obras* 336). Margarita and Katherine form his poetic center, sometimes exchanging places, other times blending into a fused entity. The topic has not been without contention, but by the late 1930s and early 1940s, the romantic drama had begun to settle down. By 1940, letters from Katherine be-

come scarce while letters to Margarita flow generously again when Salinas travels about America.

Salinas traveled so extensively he began to reduce tourism down to a science. He visited places and recounted to his wife moments in letters, making sure to inform her of the day's events and his thoughts about her. On Saturday, June 17, 1939, he writes a letter while on a trip through Arizona and other points of interest. The following quote is quite long, but indispensable in understanding his *joie de vivre* while he creates his theory of tourism. Notice how profound and thoughtful his observations are when he perceives.

Otro día estupendo. Estaba cansadísimo, anoche, me pasé diez horas en la cama y me he levantado al pelo. Y en seguida, a lo mismo, a ver, y a ver. Por la mañana un recorrido en autocar, parándose en los mejores puntos de vista. Y ahora, después de comer, dejaré el rebaño turístico y me iré yo solito, a pasear, a tomar el sol, y a mirar. Sabes, he descubierto que el turismo tiene tres grados, de menos a más. El primero, y elemental, es ver. La mayoría de los turistas ven, nada más. Ven lo que les enseñan, sin voluntad, porque se lo ponen delante, sin escoger ni diferenciar. El segundo grado es mirar: ya en mirar hay elección, y más actividad; se mira lo que uno prefiere e implica cierta personalidad e iniciativa. El turista decente ve todo, pero escoge y sólo mira a ciertas cosas. Y se llega al tercer grado: contemplar. Eso es lo supremo: una vez escogido lo que nos llama más la atención al corazón, se lo contempla es decir se fija la vista en ello, se pone en la vista la voluntad de penetrarlo con el alma, y así va uno apoderándose de ello. Es el grado supremo, porque al llegar a él el turismo queda abolido: ya no se anda, no nos movemos. Plus de tours! El verdadero turismo conduce a la contemplación, ¿no te parece? A pararse, a no andar más. ¡Jardines de Granada!

Ya ves cómo estoy desarrollando una teoría nueva del turismo. ¿Te gusta? Es un tanto mística, me parece. Pero ellos tenían razón en que la forma superior de conocimiento es la contemplación, no la acción. La posesión por la contemplación es mucho más pura. La posesión por la acción, empieza en la fiera. Adiós, guapa. Ves que estoy animado. Salgo esta tarde y mañana en Los Ángeles. ¿Estarás tú allí haciendo de ángel suplementario?

Another great day. I was very tired, last night, I spent ten hours in bed and I got out of bed feeling great. And straight away, the same, seeing, and seeing. In the morning a trip by coach, stopping at the best viewpoints. And now, after eating, I will abandon the tourist herd and leave all by myself, to go for a walk, to take in the sun, and to look. You know, I have discovered that tourism has three degrees, from least to greatest. The first, and elementary, is seeing. The majority of tourists see, nothing more. They see what is shown them, without will, because they are placed before it, without choosing or differentiating. The second degree is looking: now in looking there is a choice, and more activity; the thing looked at is what one prefers and it implies a certain personality and initiative. The decent tourist sees everything, but chooses and only looks at certain things. And then comes the third degree: contemplating. That is the supreme: once chosen what best calls attention to our heart, we contemplate it that is to say the view is fixed on it, the will to penetrate it with the soul is placed in the view, and so one becomes overpowered by the thing. It is the supreme degree, because upon arriving to the person tourism is left abolished: now walking stops, we do not move. *Plus de tours!* Real tourism leads to contemplation, don't you think? To stop, to no longer move. Gardens of Granada!

Now you see how I am developing a new theory of tourism. Do you like it? It's a bit mystical, it seems to me. But they are right in that the higher form of knowledge is contemplation, not action. Possession because of contemplation is far more pure. Possession because of action, it starts in the brute. Goodbye, doll. You see how I am *in high spirits*. I leave this afternoon and in the morning Los Angeles. Will you be there playing the additional angel? (Salinas, *Cartas de viaje* 109, emphasis in original)

Salinas shows how open and personal he is with his thoughts and with his love. His personal theory of tourism parallels phenomenological intentionality quite nicely. His first degree of tourism, seeing, satisfies the basic concept of filled intentions. The subject simply allows some things to appear while disregarding other objects. The second degree, looking, corresponds to intending the object's "sides, aspects, and profiles" (Sokolowski 20). The subject exerts more energy by physically moving the object or moving him or herself, literally or imaginatively, to intend the different sides of the object. Intuition fits

closely with this concept. The subject intuits the object and recognizes its properties. The third degree, contemplating, is the key to intend truly the object in its essence. It takes time to contemplate upon what one sees, and Salinas practices this faithfully.

A critic notes Salinas's type of contemplation as follows: "Contemplar: trascender la apariencia, hasta tocar con las manos, estremecidas por el cansancio de la vida, «el alma de las cosas»" ("Contemplate: to transcend appearance, until touching with the hands, trembling because of the weariness of life, 'the soul of things'") (Vila 65). Contemplation is an action in which the subject intends with his body the object of his vision. Contemplation is one characteristic the poetic self encourages his beloved to do throughout the trilogy of poems mentioned previously. Salinas observes the behavior of other tourists as only fulfilling the first degree of tourism, merely seeing. The introspection one gains from it reveals not just the essence of the object, but also the essence of oneself. A psychological mirror reflects the aspirations and qualities of the subject, inducing a desire to see ordinary objects in a new light or changing an attribute of one's character. When done properly, contemplation helps the beholder gain much more than just an appearance. For Salinas, many things he sees while he travels point back to his poetic center. Whenever Margarita or Katherine fills an intention, in the form of a memory, a letter, or a photo—or an empty intention by way of distance—it does not matter to him. He communes with either of them in any place and at any time. She is one with him when he remembers her, for the memories he brings about her fill him with a perception based on experience.⁴

In the next few sections, we will see how Salinas contemplates natural scenery during a trip he makes in 1940. As usual, he writes to Margarita and to his children from time to time. Salinas plans to attend a literary conference in Los Angeles, California, but on the way he takes a peripatetic opportunity and schedules plenty of time to see the sights for a week before the conference convenes. The historical background that allows Salinas to take his trip at this time will intersperse these sections as well.

⁴ For purposes of this essay, we need to note that Salinas's poetic center revolves around Margarita more than around Katherine. As we focus on a particular year, Salinas writes a letter to Katherine on Monday, December 10, 1939, before he travels through western states roughly nine months later (Obras 798-802). He writes her again in December 1940, but this letter is unusually short and wishes her a happy holiday season (865-66). The tone implies that Katherine has cut off most contacts with Salinas for quite some time. Therefore, Margarita assumes a larger role as his poetic center during this time period.

St. Louis, Missouri

Salinas writes his first letter to Margarita in Saint Louis. It is Saturday, August 3, 1940, and while waiting for his train connection he takes the opportunity to jot down his observations. He spends considerable time discussing how he sees light and water interact. Water acts like light emitting its own shine while light acts like flowing water of “pura esencia” (“pure essence”) (Salinas, *Cartas de viaje* 141-42). Yet he states, “Sobre todo, no pude *contemplantarlo*” (“Above all, I was unable to *contemplate it*.”) (142, emphasis in original). He reaches an intuition about how both forces behave and react to each other. Time may have impeded him to reach the contemplative stage. Nevertheless, the appearance reminds him of previous experiences with Niagara Falls and the Grand Canyon. Through memory he revisits these places and reaches the third stage of tourism when he contemplates these famous places. He writes, “No obstante, ahora el Niágara, como el año pasado el Grand Canyon, me dan las dos sensaciones de naturaleza más grandes y majestuosas. En este país de lo *nice*, de lo *sweet*, de lo bonito, sólo estas dos maravillas compensan de tanta dulzarronería” (“However, now the Niagara, like the Grand Canyon the year before, the two give me the most great and majestic sensations of nature. In this country of the *nice*, of the *sweet*, of the lovely, only these two wonders make up for so much saccharinity”) (142, emphasis in original).

Privacy also is an obstacle to contemplation of his surroundings. Salinas notices a difference between Niagara Falls and the Grand Canyon. Niagara Falls is more easily accessible to residents of the east coast of the United States than the Grand Canyon near the west coast. Yet the western United States has more national parks with lots of space in between and fewer people. An introverted and introspective person like Salinas would have a difficult time meditating with scores of tourists around. Salinas does condescend a bit when he observes tourists constantly seeing and never contemplating. He vents his frustrations writing the following:

¡Pero qué público! La diferencia con el Grand Canyon es que allí se puede uno aislar para la visión y la contemplación, en cualquier sitio del monte, porque el cañón se ve desde todas partes. Pero aquí, sólo hay unos cuantos puntos de vista y la gente se amontona, chilla, se mueve, y saca fotos, y fotos, sin parar. En mi vida he visto más máquinas fotográficas. ¿Cómo se podría arreglar eso? ¿Democracia, nazismo? Siempre

turba, plebe. Es un sueño, ver el Niágara solo, en silencio. Sueño imposible.

But what an audience! The difference with the Grand Canyon is that over there one can isolate for vision and contemplation, in any place on the mount, because the canyon is seen from all parts. But here, there are only a few scenic outlooks and the people crowd together, shout, move, and take pictures, and pictures, without stopping. In my life I have seen more cameras. How could we fix that? Democracy, Nazism? Always mobs, masses. It's a dream, to see the Niagara alone, in silence. Impossible dream. (142)

Salinas does not have anything against photography per se, but how tourists experience settings through their cameras: “Ya sabes que me gusta la fotografía” (“You already know that I like photography”) (*Obras* 324). Salinas wishes that tourists in general should slow down and think about what they see. They miss the point when they intend objects superficially, take pictures, and move on to the next sight repeating the same thing. Tourists who frame scenery through a viewfinder in a camera intend the place differently than others who do not. Effectively, the camera distances the subject from the object further through an artificial lens and packages a portion of the landscape into a small, deformed, rectangular surface. Later, a tourist develops the picture and marvels over intending the pictorial representation more than the visceral experience he or she had. Years later, the same picture presents a different appearance to the tourists involved, and they wonder why they took the picture in the first place. One should intend the object purely, without filters. Salinas longs to perceive the object in its entirety, or in its pure state, filled and empty intentions alike. Salinas employs all of his senses and goes beyond them to probe the essences of the surrounding world. He experiences events. He senses the object and searches for latent possibilities of the object he wants to understand. Being alone gives him the time to reflect, to behold intensely. The interruptions of tourists, their sounds and their squabbling, detract from this meditation. If Salinas gets a chance to avoid tourists, he takes the opportunity to leave the group and finds a way to commune with the landscape in silence. In the case of Niagara Falls, it is an empty intention, but one that has been filled before. He intends Niagara Falls in its absence, in its reflective state. He also intends Niagara Falls in an imaginative state, creating a space where he beholds it without distractions. He admits though that such a desire may never come true because of its popularity with the masses; hence he laments saying,

“Sueño imposible,” (“Impossible dream,”) and closes his letter (*Cartas de viaje* 142).

Manitou Springs, Colorado

He wrote his next letter to Margarita while staying at the Hotel Grand View in Manitou Springs, Colorado. He is near Pikes Peak and plans to go to the summit the next day because he misses the tour bus. The tardiness of the train does not faze him. In fact, he recounts the sensations he feels during the trip while seeing the prairie landscape and he allows the land to recall his native land. “Happy and sad at the same time,” writes Newman, “Salinas hovered in that delicate balance between prospect and retrospect [...]. Spain was superimposing itself on America, [...] the lands seemed to remember their Spanish origins” (177).

One of the most unfortunate moments Salinas had to face was becoming an exile from his native country. During the years preceding the Spanish Civil War, Salinas saw the political complications playing out between the right and the left. Although sympathetic to the Second Republic, he understood the gravity of the situation and prepared his family to leave Spain. Luckily, he corresponded with an Alice Bushee of Wellesley College and obtained employment as a distinguished visiting professor (Salinas, *Cartas de viaje* 59-61). Enric Bou relates in a footnote that Salinas, “Tuvo dificultades para encontrar un medio de abandonar España por mar, puesto que la frontera terrestre estaba cerrada. Por fin surgió la posibilidad de salir en un barco de guerra norteamericano, el ‘Cayuga’” (“He ran into obstacles to locate means to abandon Spain by sea, since the border by land was closed. At last the possibility of leaving emerged in a North American warship, the ‘Cayuga’”) (62).⁵ He embarked and made his way to Wellesley, Massachusetts, to teach Spanish literature to young women.

As an exile, Salinas reminisces from time to time about certain parts of Spain on the train ride he just had. On the train, he spends

⁵ See footnote 66 that appears on page 62 of *Cartas de viaje* to read about Salinas's experience before embarking. Because of the suspicion towards artists and literary critics, the military personnel inspecting his luggage found a copy of one of his plays. The probability of getting arrested intensified until a sailor said, in effect, that the boat was ready to sail. Salinas then leaves Spain on August 31, 1936, never to return. His wife and children do not accompany him, but leave for Maison Carrée (now El Harrach), Algeria, to wait and find another way to leave the Old World. By the time Salinas takes this trip through the United States, he and his family have already reunited and are living in Massachusetts.

hours contemplating the landscape of Kansas. He remarks to Margarita in his letter how the landscape appears like “un paisaje castellano, sí. ¿Valladolid?” (“a Castilian landscape, yes. Valladolid?”) (*Cartas de viaje* 142). Salinas may have thought about Katherine for a moment, his “Gran Duquesa de Kansas” (“Grand Duchess of Kansas”) (*Obras* 373).⁶ Other times, he thinks of “Burgos, tierra parda y gris, apenas ondulada y montañas azuleantes, al fondo” (“Burgos, brown and gray land, scarcely undulating and bluish mountains, in the background”) (142). Then he sees another essence of what makes Castile the way it is compared to its sister in America. Salinas writes:

Pero sólo la tierra es como Castilla. ¡Cómo se echan de menos aquellos pueblos, con la torre de la iglesia, a veces con el castillo! Son el alma de la tierra, ahora lo siento. Y ésta es una Castilla que no puede engañar, sin alma, sin iglesias, sin castillos. Paisaje sin historia, simplemente pobre. Apenas poblado, muy de lejos en lejos hay unas casuchas de madera, sucias, como de gitanos. Y por los caminos, blancos como los castellanos, el eterno auto, la marca de América. Si con los ojos veía al aparecer Kansas, datos reales, tierra semejante, pero el alma no se equivocó. Parece una tontería, pero ciertos paisajes necesitan historia. No los verdes, que parecen jóvenes siempre, y por eso sin historia. Pero sí los otros. Hoy he comprendido cómo Castilla es mucho más que pobre: por su historia. Y no es que se la conozca o sepa, no. Es que está allí, ya dentro, hecha una con lo terreno, en cruce eterno con el Espíritu, no literatura.

But only the land is like Castile. How one misses those villages, with the church spire, sometimes with the castle! They are the soul of the earth, now I feel it. And this is a Castile that does not deceive, without soul, without churches, without castles. A landscape without history, simply poor. Hardly settled, very few and far in between there are some wooden hovels, dirty, like those of Gypsies. And through the routes, white like the Castilians, the eternal car, the *mark* of America. If the

⁶ The comparison of Kansas with Castile recalls a letter Salinas writes to Katherine during a train trip on December 14, 1932: “¡Qué gris, qué parda, qué austera Castilla, esta que voy atravesando, mientras te escribo! [...] Y toda Castilla parece estar poblada por esqueletos en pie” (“How gray, how dun, how austere Castile, this that I go crossing, while I write you! [...] And all Castile seems to be filled with standing skeletons”) (*Obras* 345).

eyes could see Kansas upon showing up, real facts, similar land, but the soul was not wrong. It seems a silly thing, but certain landscapes *need* history. Not the green ones, that appear always young, and therefore without history. But the others do. Today I have comprehended how Castile is much more than poor: by its history. And it is not that it is recognized or known, no. It is because it is there, already within, made one with the terrain, in eternal crossing with the Spirit, not literature. (142-43, emphasis in original)

Salinas lets the landscape recall memories of Spain within him. He relives experiences and reflects upon them within the new reflection of the American plains. He notices how rich in history the poor terrain of Castile is. The memories he reenacts within his soul cause him consciously to have empty intentions of the churches, castles, and houses he used to see. Not only that, but the reflection also awakens a memory about his relationship with Katherine. He, like the Castilian terrain, needs a history, which he does carry from Spain to the United States. It is already within him, “en cruce eterno con el Espíritu, no literatura” (“in eternal crossing with the Spirit, not literature.”) (143). He is not the only poet from his generation that transposes Spain onto the American landscape. Seeing the homeland appear in transcendent juxtaposition with an adopted landscape is not new. Other members of the Generation of 1927 have similar experiences as well as Salinas. The ghostly manifestations of Spain remind members of this group that what they remember can express not just memories, but also bodily reactions or homesickness. These poets transform their experiences into literary works, giving a portion of their being to poetic patrons who read their creations on paper. Like the artist who paints with his hands and not his mind, the poet writes with his hands what he has in mind (Merleau-Ponty 57).

Salinas mentions in his letter that despite the train's tardiness to arrive in Colorado on time, he tells how “el viaje en tren ha sido muy curioso” (“the train trip has been very curious”) (*Cartas de viaje* 142). He describes the characteristics of the vehicle as “Tren bueno, cómodo y fresco, coche salón, sin gente” (“Good train, comfortable and fresh, lounge car, without people”) (142). When he mentions “coche salón” (“lounge car”), he may be referring one like the one shown in Figure 1. This lounge car gives travelers a complete panoramic view of the countryside. With the benefit of few passengers on board the train, Salinas would certainly take advantage of the “silencio” (“silence”) necessary to contemplate the American/Spanish landscape. The Utah Parks Company, a subsidiary of the Union Pacific Railroad, offered these

lounge cars as a way to pamper its guests while they made their way to destinations. The lounge car transported the exiled poet from one place to another while he contemplated the significations before him, around him, and in him during his journey.

Salinas ends his letter with anticipatory empty intentions of his next stops. He writes, “Estoy deseando llegar a Cedar City para tener carta tuya” (“I can’t wait to arrive at Cedar City to have your letter”) (143). Salinas, more than anything, intends the beloved within the appearances he perceives during his journeys. He communes with his Margarita/Katherine through memories, intentions, and significations. They encapsulate the essence of Salinas’s intentionality. He speaks only to his essence because he says, “Ya estoy bien, contento. Me gusta no hablar con nadie, y no me encuentro mal por eso. Descanso de tanto hablar [...]” (“Now I am fine, content. I like not talking to anyone, and I do not feel ill because of it. I rest from so much talking [...]”) (143). At last, through a mixture of imagination and experience, Salinas signs off writing, “Te abrazo, Marg mía, en el recuerdo” (“I embrace you, my Marg, in the recollection”) (143). He sends the letter hoping his upcoming empty intention of an answer will become another presence of memory of his beloved.



Fig. 1. “Union Pacific Company lounge car,” photo by Union Pacific Company, no date, ph18b01i0374. Reproduced with permission of the Special Collections, Sherratt Library, Southern Utah University, Cedar City, Utah.

Cedar City, Utah

Two days later, he writes another letter to Margarita describing new intentions of nature in his travels. He does not find a letter like he hopes, but he faithfully writes anyway. “Se amontonan tanto las impresiones, Margarita mía, que no sé si te las puedo contar todas” (“The impressions pile up so much, my Margarita, that I do not know if I can tell them all to you”) (143). He visits Pikes Peak like he promises in his previous letter. On this day, the panoramic view from Pikes Peak reveals a blanket of clouds. For a normal tourist, this would be a disaster of sorts. Tourists from America would feel especially cheated because “America the Beautiful”—the famous, patriotic song written by Katharine Lee Bates—describes the land’s features from the poet’s point of view from the summit. Salinas may not have understood the disappointment they feel, but he writes what they say, “Y aún había gente que decía ‘¡Lástima que haya estado nublado! ¡No hemos visto nada!’ Echaban de menos el *plano*” (“And still there were people saying, ‘What a pity that it was overcast! We haven’t seen anything.’ They missed the *map*”) (143, emphasis in original). Forsaking maps excites the poet when tourists want the predictable. “Lo dejaría todo, / todo lo tiraría: / [...] / el azul del océano en los mapas,” (“I would leave everything, / I would throw everything over: / [...] / the blue of the ocean on maps,”) writes Salinas in *La voz a ti debida* (104-05, 107; Crispin 5). Despite cloudy conditions, Salinas ventures to find his own experience and not that of another. He contemplates the clouds willingly.

On the way up to the summit, Salinas relates to Margarita in his letter that “Una niña que venía en el auto dijo, ‘Mamá, ¡cuánto humo!’” (“A girl that came in the car said, ‘Mommy, [there is] so much smoke’”) (143). The girl, of course, is referring to the clouds as if they were smoke. Salinas’s observation of the girl’s mistake has significance in that when it comes to seeing essences, children see better than adults, even if, and especially because, they blur the things they see. He does not observe the girl’s observation as a mistake. He notices the moment because she immediately and unconsciously sees the clouds like smoke from a previous experience or from memory. She confuses smoke and clouds as one substance in an interconnected relationship in the girl’s universe. The signifier she gives the smoke/clouds outside the vehicle connotes another world as existing concurrently with the one Salinas perceives. The girl and Salinas share this world almost immediately and the objects they intend reveal new essences from these new appearances. Adults have difficulty seeing beyond the appearance of things because they have grown up delineating objects from one another.

Children, however, see objects as interconnected substances. They see them all come from one entity. Salinas captures this spirit in an earlier poem while still residing in Spain. The poetic self recalls a child that names her father, mother, and a mountain with the same name:

*«Todo lo confunde», dijo
su madre. Y era verdad.
Porque cuando yo la oía
decir «Tatá, dadá»,
veía la bola del mundo
rodar, rodar,
el mundo todo una bola,
y en ella papá, mamá,
el mar, las montañas, todo
hecho una bola confusa;
el mundo «Tatá, dadá».*

“She confuses everything,” said
her mother. And it was true.
Because when I heard her
say “Tatá, dadá,”
I saw the ball of the world
roll on, roll on,
the whole world a ball
and on it papá, mamá,
the sea, the mountains, all
done into a confused ball
the world “Tatá, dadá.” (Salinas, *Poesías* 5-6)

Salinas, as well as the poetic self in this poem, relearns how to see like a child. He sees the world, the ball, the mother, the father, the clouds, and the smoke as one.

He continues describing the clouds of Pikes Peak as though he were ascending the summit of Mount Olympus and panning the domain of Zeus above the golden clouds. Salinas takes the entire view in and writes:

*Fue un camino a las nubes. Conforme ascendíamos, nos
aproximábamos más a unos vapores difusos. [...] Llegamos
hasta ellas y por fin en la cumbre, nos vimos por encima de el-
las. [...] Miré, miré, miré. Encima un cielo azul, sol vivo.
Debajo las nubes, variando de matices, sugiriendo formas. Y
nada más: lo otro, la tierra, era una sospecha, un recuerdo,*

sin nada que lo probase. [...] Al descender, muy cerca de la cima hay un recodo del camino donde se asoma uno a una especie de mirador: allí las rocas forman una rinconada, semejante a un pozo. ¿Y qué se ve? Nubes. Es un pozo de nubes, así lo bauticé yo, en mi interior. Se me venía a la memoria el verso, mejor dicho la frase, de Bécquer: "Huésped de las nieblas."⁷ Fue maravilloso, eso de pasar por todos los niveles de las nubes.

It was a path to the clouds. As soon as we were ascending, we were coming closer to more diffuse vapors. [...] We arrived up to them and finally at the summit, we found ourselves above them. [...] I looked, looked, looked. On top a blue sky, burning sun. Below the clouds, giving some variety to nuances, hinting at forms. And nothing more: the other, the earth, was a suspicion, a memory, without anything to prove it. Upon descending, very close to the peak there is a nook in the path where one looks out from a sort of viewing point: over there the rocks form a corner, like that of a well. And what can one see? Clouds. It is a *well of clouds*, thus I named it, deep down. A verse came to me in my memory, or rather a phrase, by Bécquer: "Host of mists." It was marvelous, all that passing through all levels of the clouds. (Salinas, *Cartas de viaje* 143, emphasis in original)

Salinas reaches only his second level, which is to look at the sights. He could reach the level of contemplation if he had more time to stay at each destination. Hence, he "looks, looks, looks" at the clouds and their subtle forms while emptily intending the hidden land beneath them. Memories and experiences from his studies recall other poets and their works. The impressions come to him plentifully and he concludes, "Ojalá lea algo algún día, en eso que ayer vi" ("I hope to read something some day, in what I saw yesterday") (143). He ponders on linguistic difficulties in describing what he sees and remarks the following to his beloved Margarita:

⁷ This reference comes from Gustavo Adolfo Bécquer's "Rima LXXV" ("Rhyme 75") in his collection *Rimas y leyendas*. It appears in the second stanza: "¿Será verdad que, huésped de las nieblas / de la brisa nocturna al tenue soplo, / alado sube a la región vacía / a encontrarse con otros?" (Isn't it true that, host of the mists / of the nocturnal breeze lightly puffing, / quickly rises to the empty region / to find himself with others?) (Bécquer 60).

Porque me ocurre con muchas de las cosas que veo que se me representa en ellas un a modo de conjunto de signos supremos, absolutos que no sé leer ni traducir en el sistema de signos relativos que llamamos palabras. Esas cosas inmensas me dicen algo, sí, pero no se me formula en la conciencia su mensaje, comprendes, de modo organizado y comunicable. Espero. Quizás algún día vea lo que ayer miré, hecho forma expresiva. Entretanto, o para siempre, a ti sola van estas señas de lo visto.

Because it occurs to me that many of the things that I see that are represented in them are a manner overall of supreme signs, absolutes that I know not how to read or translate in the system of relative signs we call words. Those vast things say something to me, yes, but they don't formulate their message in my consciousness, you understand, in an organized and communicable way. I wish. Maybe someday *I will see* what I looked at yesterday, made into expressive form. In the meantime, or forever, these *signs* of the seen go to you alone. (143-44, emphasis in original)

The linguistic obstacle he faces as a poet tries him endlessly. As a person probing the essence of objects, sometimes the task becomes impossible when he tries to formulate descriptions of essence from a limited pool of vocabulary. His quest for capturing this essence, like every other poet's, almost becomes impossible. Nevertheless, he succeeds as a poet who reaches the closest to portraying essence to his readers. He may intend differently than a reader, but both intentions point to the same entity. The first intends it as past experience while the second intends it as anticipatory future. Author and reader, at least, have the possibility to have the empty intentions filled again or for the first time. In his letter, Salinas intends emptily what he just sees, while his wife will read the letter and intend the same entities emptily as a person who imagines their forms in anticipation for future experience. Both join together in soul like the poetic self in a poem Salinas writes for Katherine: "Que hay otro ser por el que miro el mundo / porque me está queriendo con sus ojos" ("For there is another being through whom I look at the world / because she is loving me with her eyes") (*La voz* 808-09; Crispin 39).

Salinas travels again the next day to Salt Lake City, Utah. He takes advantage of the two-hour layover by touring the city. On the way, he sees the landscape and again has reminisces of Spain. Salt Lake City "Recuerda a Murcia, mancha de verdor en un valle mucho

más grande, inmenso” (“It recalls of Murcia, a spot of verdure in a valley much more grand, immense”) (Salinas, *Cartas de viaje* 144). He also notices, as is shown in Figure 2, that the valley is “Cercado por montañas peladas y ardientes” (“Enclosed by treeless and burning mountains”) (144).

Salinas mentions Salt Lake City only briefly in the letter to his wife, but for the Union Pacific Railroad it is one of the major hubs. Salinas never mentions the name of the railroad, but historical research verifies that the Union Pacific Railroad mainly services this part of the U.S.



Fig. 2. “Enclosed by treeless and burning mountains,” photo by Andrew Willard Bishop, 2 November 2009.

The company also fathered a tour company to organize activities and facilities within the national parks found in Utah. The smaller company called itself the Utah Parks Company. The Utah Parks Company advertised across the country, and with the help of the Union Pacific Railroad, sold tour packages to potential tourists. Salinas does not mention purchasing a tour package from the Utah Parks Company, but the venues he writes about imply that he has done so. One scholar summarized the transportation system in this manner:

For many years, tours from Chicago were sponsored by the Union Pacific in conjunction with the Chicago & North Western, leaving every Saturday. They included sightseeing stops at Ogden Canyon, Salt Lake City, and Denver, with side trips to Colorado Springs and Pike’s Peak, taking two weeks. The tour routes did not vary much over the years, but the details of the tours changed slightly. (Waite 26)

Not only did the two companies carry passengers from one place to another, but they were “directly involved in the development of these national parks and monuments” (17). To do so they contracted with individuals and the government to establish their facilities within some

parks and develop them.⁸ Salinas stayed in some of the hotels and lodges operated by the Utah Parks Company, possibly starting in Manitou Springs, Colorado, but definitely when arriving in Utah. The Los Angeles and Salt Lake Railroad Line leaves Salt Lake City heading west, and after passing the Oquirrh Mountain Range and the Great Salt Lake, it turns southbound going through the desert in western Utah.

Salinas does mention the Great Salt Lake and describes it beautifully, writing, “Luego hemos pasado junto al Lago Salado. ¡Rarisimo! A trechos como la costa de Alicante, rosa la tierra, azul el agua” (“Later we have passed next to Salt Lake. Very strange! Like the coast of Alicante in places, pink the land, blue the water”) (*Cartas de viaje* 144). By so describing the features of the landscape, Salinas leaves footprints for Margarita to follow, using “signs” she already has experienced in her life. Margarita receives the chance to behold Salinas’s presence through his letters to her. When she reads the signs and significations recorded on the page, she experiences the same things Salinas senses without having to be there physically. By imagining the landscape as analogous to other landscapes she has been familiar with, she instantly beholds the essence she already exerts in Salinas. The landscape she beholds in her intentionality is not there in the same way the Utah landscape presents itself in reality, but neither is it elsewhere.⁹ Thus, she participates with Salinas despite distances and time.

After passing the Great Salt Lake, the train takes Salinas down Tooele County into the mountains and deserts of the Great Basin’s edge. The view does not disappoint him (Fig. 3). “Y el viaje hasta aquí estupendo: tierras secas, desoladas, y montes y montes varios de forma, rosados de color con su horizonte dilatadísimo y una luz radiante, sin un árbol” (“And the trip up to here wonderful: dry lands, desolate, and mountains and mountains diverse in shapes, rosy in color with their very vast horizon and a radiant light, without a tree”) (144). The

⁸ Other historians recount the founding of the Utah Parks Company this way: “The Utah Parks Company, a subsidiary of the Union Pacific Railroad Company was officially incorporated in 1923. [...] Through a series of agreements, leases and contracts, the Utah Parks Company became a major factor in the development of the tourist industry at Zion, Bryce and Grand Canyon National Parks and Cedar Breaks National Monument. The company developed and operated the transportation facilities at these national parks. The transportation facilities included the operation of the railroad services between the parks as well as the tour buses within each park. The Los Angeles and Salt Lake Railroad Line, also controlled by the Union Pacific Railroad, played a major part in the development of the transportation facilities” (Kellough and Rowley 1).

⁹ The presence of Margarita despite her absence coincides with Merleau-Ponty’s example in “Eye and Mind.” “The animals painted on the walls of Lascaux are not there in the same way as are the fissures and limestone formations. Nor are they *elsewhere*” (126, italics in original).

desolate and dry lands become filled intentions for the spiritual poet while trees surprisingly become empty intentions. Unlike the short times he spends at parks, he has time to contemplate what he beholds during train rides.



Fig. 3. “Plays of sun and shadow in their violent forms,” photo by Andrew Willard Bishop, 31 January 2010.

The scene carries on for hundreds of miles. He scans the land and sees “Cortinas y cortinas de sierras y juegos de sol y sombra en sus formas violentas” (“Curtains and curtains of mountain ranges and plays of sun and shadow in their violent forms”) (144). The shadows may recall a poem from *La voz a ti debida* in which the poetic self exclaims:

*Tú no puedes quererme:
estás alta, ¡qué arriba!
Y para consolarme
me envías sombras, copias,
retratos, simulacros,
todos tan parecidos
como si fueses tú.*

You can't possibly love me:
you are glorious, how you dazzle!
And to console me

you send me shadows, copies,
 portraits, simulacra,
 all so like you
 they might as well be you. (1728-34; Crispin 83)

The shadows are but images of his beloved but are not the beloved herself. Salinas sees Margarita and Katherine in these appearances, but these appearances are not Margarita and Katherine themselves. The features veil the presence of the beloved in both cases. The poetic self responds to the simulacra saying:

*Yo vivo
 de sombras, entre sombras
 de carne tibia, bella,
 con tus ojos, tu cuerpo,
 tus besos, sí, con todo
 lo tuyo menos tú.*

I live
 from shadows, among shadows
 of warm, lovely flesh
 with your eyes, your body,
 your kisses, yes, with everything
 of you except you. (*La voz* 1754-59; Crispin 83)

The beloved's essence flees from the poetic self, and Salinas finds other essences standing in place of the beloved. Like the shadows that mingle with the shine of the beloved's light, he ebbs and flows to and with her consciousness. Salinas recounts the images of the landscapes, their shadows and radiance, to Margarita/Katherine¹⁰ as though she has

¹⁰ Surprisingly, even though Salinas is writing to his wife, he may be thinking about Katherine at any moment on this trip. Most of the references, if not all, of shadows and symbols come from Katherine's inspiration. It is possible at this point for Salinas to dwell on his mistress for a time without having to mention this provocative character to his wife. On the other hand, Katherine admits that some elements in *La voz a ti debida* do not originate from their affair. Katherine confirms this in part writing, "Es cierto que poemas [...] pertenecen claramente a nuestro amor naciente, pero otros, sumamente apasionados, implican una experiencia que no conocimos" ("It's true that poems [...] clearly belong to our budding love, but others, extremely passionate, imply an experience that we never knew") (Whitmore 1524). "It is not unthinkable," writes Newman, "that the essential focus of the love theme as developed later in *La voz* may have had its genesis in Salinas' outpourings to Margarita" (57). One cannot ignore Margarita in the formation of the beloved. Until further evidence appears, we must conflate Katherine and Margarita in these shadows.

already sent these filled intentions to him. Salinas moves as though the appearances come to him, and not he to them.

The land offers Salinas solitude as he exercises his intentionality upon it. Outside the metropolitan area of Salt Lake City, the population is very sparse. He finds spiritual rejuvenation and writes, "Y ni una casa, ni un alma, en leguas y leguas" ("And not even a house, not even a soul, for leagues and leagues") (Salinas, *Cartas de viaje* 144). The railroad tracks act a connection bridging great chasms that are "enormes fosas llenas de su falta" ("enormous cavities full of her absence") (*Largo Lamento* 1502). The distance he has from her only intensifies the bond he has with her like an imaginary bridge that gets stronger as it grows longer. "¿Qué habría sido de nosotros, di, / si no existieran puentes? / Pero hay puentes, hay puentes. ¿Los recuerdas?" ("What would have become of us, tell me, / if there had been no bridges? / But there are, there are bridges. Do you remember them?") (1969-71; Crispin 223). Space is a unifying force and not a dividing one. One may ask, upon reading the complete collection of letters, why Salinas would allow separating himself from her often. His answer comes from a letter he writes to Margarita on July 6, 1941. He writes:

¿Qué es ese espacio tan grande que dices que se ha ido formando, por tu parte, entre tú y yo, Margarita? No te entiendo bien. ¿Une o separa ese espacio que tú sientes? ¿Es espacio de respirar, de moverse, de vivir, o espacio de distancia? No te lo pregunto, claro. Me lo pregunto. Tú estás donde estás, donde quieres estar. Yo sé dónde buscarte. "Porque tú tienes las señas –Donde tuviste las alas.""¹¹ Hazte todo el espacio que quieras, que necesites. No me importa, porque el espacio se traspasa y recorre en un segundo. [...] Y la vida misma es espacio, espacio ilimitado, en el que se puede uno volver con la vista a todas partes, dejándola volar. Bendito tu espacio, si lo usas con tus alas. Alguna vez me encontrarás por él, porque yo ando rondando, con las alas que me haya dado Dios, flojas o vigorosas, por ese espacio, también.

What is that space so big that you say that has been forming, on your part, between you and me, Margarita? I don't under-

¹¹ Pedro Salinas refers to a line from Rubén Darío's "La lira de siete cuerdas" ("The Lyre of Seven Strings"). The line comes from the "I cuerda" ("First String"): "Luz y gloria son tus galas, / ángel eres, y en Dios sueñas: / Tú debes tener las señas / donde tuviste las alas" ("Light and glory are your finery, / angel you are, and in God you dream: / You must have the signs / where you received your wings") (Silva 158).

stand you well. Does that space that you feel unite or separate? Is it space to breathe, to move, to live, or space of distance? I am not asking you about it, of course. I ask myself. You are where you are, where you want to be. I know where to look for you. “Because you have the signs –Where you received your wings.” Make yourself all the space that you want, that you need. It matters not to me, because space exceeds itself and travels in a second. [...] And life itself is space, unlimited space, where one can return with the gaze towards all places, letting it fly. Happy your space, if you use it with your wings. Sometimes you will meet me within it, because I go roaming, with wings that God has given me, idle or vigorous, through that space, as well. (Salinas, *Cartas de viaje* 158-59)

Here, Margarita is the center for Salinas, not the other way around. He gives her space according to her needs. Like the poetic self in *Largo Lamento*, he would rather “volverse sombra” (“to become shadow”) than suffocate the one he loves (1685-887). Other ways exist to conjure the lover: “Por lejos que se esté si digo: ‘tú’, / si dices: ‘tú’, se pasa invariablemente, / de mí a ti, de ti a mí” (“As far away as I may be if I say: ‘you’, / if you say: ‘you’, we move invariably, / from me to you, from you to me”) (*Largo Lamento* 2003-05; Crispin 225). He reiterates this sentiment again in a letter, dated September 7, 1947, which reads, “Te digo otra vez, que esté donde esté, haga lo que haga, y vea lo que vea, siento como un centro de gravedad espiritual, que eres tú, que desde lejos gobierna mi bienestar o mi preocupación” (“I tell you again, wherever I am, whatever I do, and whatever I see, I sense [something] like a center of spiritual gravity, that is you, from afar that governs my wellbeing or my worry”) (Salinas, *Cartas de viaje* 209).

Neither space nor distance bothers Salinas. He sees the center, the essence, the filled intention of objects, in everything he sees. All his intentions, filled and empty, point to the same entity. He penetrates the veil with his contemplation of his beloved. He finishes the letter and writes: “Ayer, Marg, una embriaguez pura de nubes, hoy de montañas y tierra pura y desnuda. [...] Estoy contento. Gozo honda y permanente, con los ojos y el alma. Lo demás es servidor de ellos. Te abrazo en lo que siento” (“Yesterday, Marg, a pure intoxication of clouds, today of mountains and pure and naked land. [...] I am content. Profound and permanent joy, with the eyes and the soul. The rest is at their service. I embrace you in what I sense”) (144).

Salinas saw these landscapes until the train stopped at Lund, Utah, where he then caught a local train that took him to Cedar City, Utah. Roughly 30 miles later, the train pulled into a depot (Fig. 4). Across



Fig. 4. “Train Station In Cedar City,” photo by Anderson, 1949, ph18b01i0006. Reproduced with permission from the Special Collections, Sherratt Library, Southern Utah University, Cedar City, Utah.

the street to the south was El Escalante Hotel, where tourists taking tours provided by Utah Parks Company spent their nights. This was where Salinas hoped to find a letter waiting for him, but upon finding out none was waiting, he wrote to Margarita instead. He slept there one night and started his tour of national parks the following day (Fig. 5).



Fig. 5. “Escalante Hotel,” photo by Anderson, 1948, ph18b01i0007. Reproduced with permission from the Special Collections, Sherratt Library, Southern Utah University, Cedar City, Utah.

Bryce Canyon National Park

“By 1931,” remarks Waite, “the Utah Parks Company was operating 65 buses out of Cedar City over 459 miles of intrastate roads and 195 miles of interstate highways” (26). The company set up its headquarters in Cedar City because of its convenient location to nearby parks and the station that the Union Pacific Railroad had built for that purpose. Waite also informs that:

While the railroad would build the new branch line and park facilities, the Utah Parks Company would provide a loop tour of the parks in new motor coaches. Although longer or shorter stays could be arranged, the tourist would be able to visit Cedar Breaks, Kaibab National Forest, and the Grand Canyon, Bryce, and Zion National Park in a loop tour which normally took five days. (23, see Fig. 6)



Fig. 6. “Cedar City Railroad Depot,” photo source: Lois Iverson, no date, ph18b01i01344.jpg. Reproduced with permission from the Special Collections, Sherratt Library, Southern Utah University, Cedar City, Utah.

Salinas must have decided to take a loop tour of only two days, because once he reached Los Angeles on August 10, 1940, three days have already passed, supposing he takes a day traveling to his final destination (*Cartas de viaje* 145).

According to *Hi-Way Map to Zion-Bryce Canyon, Grand Canyon National Parks*, by 1940, Highway 14 was an “improved road” consist-

ing of gravel, stone, shell, or sand clay.¹² Salinas may have visited Cedar Breaks National Monument because it lies just a couple of miles off Highway 14, but he does not mention it in his letters. In any case, the tour bus drives up Highway 14 until turning north on Highway 89, which is paved. The bus continues to Bryce Junction to connect to Highway 12 and arrives at the Bryce Canyon National Park Lodge within the park (Fig. 7). Inside the park, the tourists can again take advantage of a paved road all the way to Rainbow Point. The map also mentions rates, and according to the room Salinas describes in his letter to his children, he may have reserved a Standard Sleeping Lodge Room, European plan (without bath) at \$2.25 per day.



Fig. 7. “Bryce Lodge Flexible Bus,” photo source: Joe Ott, no date, ph18b01i0039. Reproduced with permission from the Special Collections, Sherratt Library, Southern Utah University, Cedar City, Utah.

This time, Salinas writes to his children, Solita and Jaime Salinas, on August 7, 1940. He writes a descriptive account of his lodgings at the Bryce Canyon National Park Lodge and includes a reference to a famous Spanish play:

Nobles vástagos: ¿Os acordáis, oh ignaros, de aquellos versos del “Tenorio”?: “Yo a los palacios subí — yo a las cabañas

¹² Highway 20, an alternative route by way of northern Iron County and Panguitch, Utah, did not exist in 1940.

bajé.”¹³ *Pues vuestro padre perillustre, después de haber subido a hoteles-palacios esta noche va a dormir en una cabaña de madera. Como Robinson Crusoe. Porque este Hotel es una Federación de cabañas, en torno a un edificio central, donde no hay apenas cuartos. Y a mí me ha tocado una cabaña muy cuca, con luz eléctrica y todo, pero con la jofaina y el jarrito de nuestra España. (Márquese en los fastos de mi historia como efemérides sin par que por primera vez voy a dormir en U.S.A. en un cuarto sin agua corriente.) Por lo demás el Hotel es muy simpático. Figuraos (¡y aprended!) que todos los que sirven a la mesa y cogen las maletas y están en la oficina, son estudiantes de College u Universidad que, así, trabajando tres meses, se ganan su matrícula. ¡Ánimo para la temporada de 1941, niño! El viaje estupendo.*

Noble offspring: Do you remember, oh uneducated ones, those lines from “Tenorio”? “I rose to the palaces — I fell to the cabins.” Well your very illustrious father, after having risen to hotel-palaces tonight is going to sleep in a wooden cabin. Like Robinson Crusoe. Because this Hotel is a Federation of cabins, around a central building, where there are hardly any rooms. And it became my turn to get a very cute cabin, with electric lights and everything, but with a washbasin and a pitcher from our Spain. (Let it be written in the archives of my history like a matchless anniversary of events which took place on this day that for the first time I am going to bed in the USA in a room without running water.) For the rest the Hotel is very nice. Imagine (and learn!) how everybody, those that serve tables and retrieve suitcases and work in the office, are College or University students that, in this way, working three months, earn their tuition. Courage for the 1941 season, son! A stupendous trip. (Salinas, *Cartas de viaje* 144-45)

Fig. 8 depicts one of the cabins that surrounded the main lodge.

He continues his letter to his children about observations he has made while making the trip with other tourists. Again, he does not

¹³ Pedro Salinas makes a reference here to the play *Don Juan Tenorio* by José Zorrilla. The complete verse reads, “Yo a las cabañas bajé, / yo a los palacios subí, / yo los claustros escalé / y en todas partes dejé / memoria amarga de mí” (“I fell to the cabins, / I rose to the palaces / I burgled the cloisters / and in all places I left / bitter memories of me”) (Zorrilla 206).

appreciate how tourists go from one venue to another with cameras. He vents his frustration.



Fig. 8. “Cabin,” photo by Bain or Libbie Matheson, 1949, ph18b01i0167. Reproduced with permission from the Special Collections, Sherratt Library, Southern Utah University, Cedar City, Utah.

No ven, no miran, sino lo necesario para escoger el “tema” y fotografiarlo. De donde deduzco el siguiente sabio apotegma: La actitud del turista hacia los paisajes es la misma que la del cazador hacia la fauna: ver, apuntar, disparar y seguir hasta la próxima presa. Supongo que luego, al volver a casa, verán en foto, lo que no pudieron ver en realidad porque se les pasó el tiempo en hacer fotos. ¡Técnica de turista!

They don't see, they don't look, except for the necessary to choose the “subject” and photograph it. From whence I infer the following wise maxim: The attitude of the tourist towards landscapes is the same as the hunter's towards fauna: look, aim, shoot and continue to the next prey. I suppose later, upon returning home, they will see in the photo what they couldn't see in reality because time swept by them while taking pictures. Technology of tourists! (145)

He sees the tourists staying maddeningly in the first stage of his theory of tourism. They do not take advantage of experiencing with their bodies the landscape around them. It is as though they settle with photographic or pictorially filled intentions and representations rather than the real objects themselves. They may contain a record of having been to places, but they do not carry the memories of them in their

souls. Salinas continues, however, doing what he does best and probes the essences of objects to pierce their veils of empty intentions.

Salinas wrote to Margarita when he arrived at Los Angeles on August 10, 1940. This time, the recollections of his intentionality overwhelm him with what he has seen during the previous two days. On August 8, he had gone along with the tour group to take in the vistas at Bryce Canyon. “He venido siguiendo un verdadero camino de maravillas” (“I have come following a true path of wonders”), writes Salinas (145). The two days he spends sightseeing “fueron prodigiosos” (“were prodigious”) (145). He describes two national parks to Margarita, overwhelmed by the visions he sees.

Bryce Canyon becomes a fascinating landscape with ambiguous appearances. He writes, “El primero es un fantástico y enorme anfiteatro de piedras de color rosa, rojo, bermellón, gris y blanco, que por la erosión del tiempo y las aguas, han tomado las más extrañas formas” (“The first is a fantastic and enormous amphitheater of colored rocks of pink, red, vermilion, gray and white, that by the erosion of time and the rains have taken the most peculiar shapes”) (145-46). Merleau-Ponty asserted color necessitated touch in order for the subject to perceive the essence of the object (125). Salinas perceives the colors of the sandstone transcendently, just like the poetic self intends the seashell in “La concha” (“The Shell”):

*Entreabierto, curva, cóncava,
su albergue, encaracolada,
mi mirada se hace dentro.
Azul, rosa, malva, verde,
tan sin luz, tan irisada,
tardes, cielos, nubes, soles,
crepúsculos me eterniza.*

Half-open, curved, concave,
its refuge, sea shelled,
my gaze becomes inward.
Blue, pink, mauve, green,
so without light, so iridescent,
evenings, heavens, clouds, suns,
twilights eternize me. (Salinas, *Poesías* 67)

He transcendently intends the stone, an object that originates from nature, as well in “La memoria en las manos” (“Memory in My Hands”).

*A tiempo sabe
 el peso de una piedra entre las manos.
 En una piedra está
 la paciencia del mundo, madurada despacio.
 Incalculable suma
 de días y de noches, sol y agua
 la que costó esta forma torpe y dura
 que acariciar no sabe y acompaña
 tan sólo con su peso, oscuramente.*

The weight of the stone between the hands
 tastes of time.
 In a stone lies
 the patience of the world, slowly ripened.
 The incalculable sum
 of days and nights, sun and water
 which it took to form this hard and awkward shape
 that can't caress and keeps us company
 with only its weight, darkly. (*Largo Lamento* 1899-907;
 Crispin 233).

His contemplation, manifested by these examples, allows him to imagine the time and the forces shaping the features of the national park.

Salinas then describes the features of the park saying, "Se sienta uno al borde de ese abismo de maravillas y la vista se pierde entre formas de lo infinitamente posible" ("One feels on the edge of that abyss of wonders and the view loses itself among forms of the infinitely possible") (*Cartas de viaje* 146). The infinity presented to Salinas acts like a metaphysical darkness penetrated by the light of his inward gaze and reach, uncovering knowledge as he goes. The filled intentions present themselves purely to the poet as they emerge. They also invoke images of other objects empty intended at this time. Salinas wonders writing, "¿Qué es aquello? ¿Un castillo, una catedral, un templo? Todo y nada. Pero para la interpretación de la imaginación las variaciones, las posibilidades, no tienen fin" ("What is that? A castle, a cathedral, a temple? Everything and nothing. But for the interpretation of the imagination the variations, the possibilities, do not end") (146). The confusion sweeps him back into a child-like state of perception, similar to the girl confusing clouds with smoke and the child naming everything "Tatá, dadá." He perceives the world revolving and turning in his gaze even if his adult behavior manages to distinguish everything and nothing in the

same entity. Fig. 9 shows how the canyon hoodoos give ambiguous images to the observer.



Fig. 9. “A castle, a cathedral, a temple?” photo by Andrew Willard Bishop, 2 January 2010.

The park also recalls to Salinas’s soul a painting he remembers. He comes closer to perceiving through the body and expanding his vision to the realm of the “I can” (Merleau-Ponty 124). The hellish depiction he gives of the canyon manifests another identity laced within Bryce’s sandstone. The comparison conjures up the divine and the demonic in one place, like Dante’s sublime, poetic telling of a sobering locale.

A veces es un color de primitivo, de Fra Angélico, montes de rosa, de gris, de azul, de blanco pálido. Todo lo que aquel pintor imaginaba está aquí. Otras veces, en cambio los picachos parecen un mar de llamas, un infierno petrificado, y se hunde la vista en oscuras galerías rojas y ardientes, pasillos del infierno. No he visto nada de una hermosura tan extraña.

Sometimes it is a primitive color, of Fra Angelico, mountains of red, of gray, of blue, of pallid white. All that the painter imagined is here. At other times, in exchange the mountain peaks seem like a sea of flames, a petrified hell, and the view sinks into obscure, red and burning galleries, corridors of hell. I have never seen anything of such strange beauty. (Salinas, *Cartas de viaje* 146)

Salinas contemplates these scenes deeply, although in a very short time. He laments writing, “Pasé muy pocas horas, por desgracia, allí, pero no las olvidaré” (“I spent very few hours, unfortunately, over there, but I will never forget them”) (146). The places he visits exceed expectations of previous trips, and he wishes implicitly to stay longer to probe the ontology of these objects.

Zion National Park

Salinas and the group continued their travels by heading back the way they came the day before. They returned west on Highway 12 back to Bryce Junction and Highway 89. They headed south, passing a small settlement named Mount Carmel, until reaching another junction. At the junction, they turned and headed west again on Mount Carmel Highway and reached Zion National Park. This park also left an indelible impression on the poet. He writes to Margarita, “Y luego Zion Park. Otro prodigio: un desfiladero de proporciones inmensas, larguísimo, con paredes de piedra cortadas casi a pico, y de colores” (“And later Zion Park. Another prodigy: a gorge of immense proportions, very long, with sides of cut stone almost to a peak, and of colors”) (146). What Zion lacks in texture it makes up for in size. Erosion wears away the park not bit by bit, but chunk by chunk (Fig. 10).



Fig. 10. “Zion observation point, Great White Throne,” photo source: Carl R. Croft, no date, ph18b01i0161. Reproduced with permission from the Special Collections, Sherratt Library, Southern Utah University, Cedar City, Utah.

Salinas viewed Bryce Canyon from above, standing on a plateau looking down. In Zion, however, he views the park from below,

flanked by all sides in a narrow river valley. His perception changes significantly as he sees from a different angle. Instead of intending evidence of appearances from a secure standing, he senses a vertigo surrounding him in chaotic space. “Se va por el fondo de la garganta, sobrecogido, atemorizado, y embriagado, al mismo tiempo, de tanta grandeza y hermosura” (“One goes to the bottom of the throat, taken by surprise, frightened, and drunken, at the same time, of so much greatness and beauty”) (146). The pure essence collides with Salinas’s soul, jarring his intentionality.

Before reaching Zion Canyon National Park, Salinas’s anticipatory, empty intention does not expect such grandness at this magnitude. He has seen the Grand Canyon in its splendor, but the proximity and the intimacy of Zion intrigue him more strongly. “Porque también aquí las rocas son colores: hay montes blancos, otros rojos, otros rosas” (“Because here as well the rocks are colors: there are white mountains, others red, others pink”) (146). Again, textures, or qualia of colors within the textures, play a part in helping Salinas perceive the colors (the whiteness, the redness, the pinkness) because the objects are the colors instead of comprising of colors. The essences of the rocks’ colors shed a magnificence of grandeur.

Salinas again sees the divine and the demonic. “Es una mezcla de solemnidad y poesía, como ciertos poemas religiosos, Milton” (“It is a mix of solemnity and poetry, like certain religious poems, Milton”) (146). Milton, of course, wrote *Paradise Lost*, an epic poem about the creation of Adam and Eve and their fall from grace by succumbing to the temptations of the fallen angel Satan. The poem blends the sublimity of poetry with the terrible landscapes of the abyss. The spiritual connection Salinas feels with these parks merits the attention he gives them and the mention of them to his central force, Margarita: “Estoy, Marg, como mareado, embriagado de tanta belleza natural. La he gozado con toda mi alma. Ya te contaré, todo, hablado, muy despacio. ¡Lástima, tener que meterse ahora en este Congreso ridículo!” (“I am, Marg, as dizzy, intoxicated from so much natural beauty. I have enjoyed it with all my soul. Later I will tell you, everything, very slowly. A shame, having to get involved now in this ridiculous Conference!”) (146). Fig. 11, in essence and in reenactment, portrays the connection the poet has with his beloved upon contemplating these parks. It also shows the Mount Carmel Highway that Salinas took with his tour group to reach Zion National Park.

Salinas finished his tour of national parks in Utah when the Utah Parks Company returned him and the tour group to Cedar City. Salinas caught the train at the station, rode to Lund, and caught another train heading for the “ciudad-luz, luz-ciudad” (“city-light, light-city”) on the

Los Angeles and Salt Lake Railroad Line (145). Upon arriving at his accommodations, he found a letter from Margarita waiting for him. It is an empty intention imagined since Manitou Springs, Colorado, which manifests itself as finally a filled one in Los Angeles, California.



Fig. 11. “View of Mt. Carmel switchbacks,” photo source: Homer Jones, no date, ph9b1i578. Reproduced with permission from the Special Collections, Sherratt Library, Southern Utah University, Cedar City, Utah.

He communes with his beloved through linguistic signs and significations. He promptly writes a letter and ends it recording the following: “Tu carta me esperaba aquí. Gracias, alma, gracias. Son el *otro lado* el de dentro, de las bellezas que he estado viendo. Por eso me siento hoy contento y feliz, Marg, y te lo digo para tu alma” (“Your letter was waiting for me here. Thank you, my love, thank you. They are the *other side* of the inside, of the beauties that I have been seeing. That’s why I feel today, content and happy, Marg, and I tell it to you for your soul”) (146, emphasis in original). Margarita Bonmatí has always formed the center for Salinas. At this moment, she is his beloved, his essence, and his communion. She represents and is represented by all evidence within his perception. He lives for her. Salinas explains it best in the following poem he wrote for Katherine from an earlier time:

*Qué alegría, vivir
sintiéndose vivido.
Rendirse
a la gran certidumbre, oscuramente,
de que otro ser, fuera de mí, muy lejos,
me está viviendo.
[.....]*

*La vida —¡qué transporte ya!—, ignorancia
de lo que son mis actos, que ella hace,
en que ella vive, doble, suya y mía.
[.....]
Con la extraña delicia de acordarse
de haber tocado lo que no toqué
sino con esas manos que no alcanzo
a coger con las mías, tan distantes.*

What a joy, to live
feeling yourself lived.
To surrender
to the great certainty, darkly,
that another being, outside of me, very far away,
is living me.

[.....]
Life—what ecstasy! ignorance
of what my acts are, which she performs,
in which she lives, double, her life and mine.

[.....]
With the strange delight of remembering
having touched what I never touched
except with those hands that I cannot reach
and take into mine, so distant are they. (*La voz* 792-97, 813-
15, 821-24; Crispin 39)

Pedro Salinas lives through Margarita Bonmatí and Katherine Whitmore, and they live through Pedro Salinas. Despite distances, they are together. Despite distances, Salinas sees his poetic center's essence or presence within landscapes. Landscapes are connections and portray a message using a language Salinas cannot decipher entirely. Through these essences he reaches his beloved. In his letter of July 6, 1941, he compares the temporary distances he has with Margarita to the space in which a bird flies:

*Espacio, tiene para mí sensación de amplitud, de claridad, de
aire circulante. Lo cual quiere decir que un espacio, para mí,
sólo separa si no se tiene voluntad y afán de surcarlo, de re-
correrlo. Hoy estaba yo pensando en las palabras de tu carta,
en la terraza, mirando vagamente al aire. Espacio. En el es-
pacio lo árboles las ramas. Y de cuando en cuando, de un ár-
bol a otro, como una flecha, cruzaba un pájaro. No, el aire no*

separa, me decía yo, por lo menos a los pájaros. Lo terrible para los pájaros sería que no hubiese espacio. La jaula es la limitación brutal de espacio.

Space, it has for me a sensation of amplitude, of clarity, of circulating air. The idea means that a space, for me, only separates if we don't have will and zeal to ply it, to travel it. Today I was thinking the about the words of your letter, on the balcony, looking vaguely in the air. Space. In space the trees the branches. And from time to time, from a tree to another, like an arrow, a bird was crossing. No, air doesn't separate, I was telling myself, at least for the birds. The terrible thing for birds would be that there was no space. The cage is the brutal limitation of space. (Salinas, *Cartas de viaje* 159)

Freedom and will allow Salinas to connect with his beloved through space like a bird needs air to take flight. Essences are what Salinas needs to connect with and understand the center of his world. His body and his soul are one. They perceive the physical visible and the transcendental invisible in the world and transform them into letters and poetry, dedicated to a gravitational center that anchors Salinas's revolutions.

Bibliography

Bécquer, Gustavo Adolfo. "Rima LXXV." *Rimas y leyendas*. Barcelona, Sp.: Linkgua, 2007. 60. *Google Books*. 23 Nov. 2010. http://books.google.com/books?id=csJyjLwLX1MC&pg=PA60&dq=B%C3%A9cquer+Rima+LXXV&hl=en&ei=YT_sTKTeCoG6sAPBq7msDw&sa=X&oi=book_result&ct=result&resnum=3&ved=0CC4Q6AEwAg#v=onepage&q&f=false.

Bou, Enric, ed. *Cartas de viaje [1912-1951]*. By Pedro Salinas. Valencia, Sp.: Pre-Textos, 1996.

Bou, Enric, and Andrés Soria Olmedo, eds. *Obras completas III: Epistolario*. By Pedro Salinas. Biblioteca Avrea. Madrid: Cátedra, 2007.

Cardwell, R. A. "The Persistence of Romantic Thought in Spain." *The Modern Language Review* 65.4 (1970): 803-12.

Crispin, Ruth Katz, trans. *Memory in My Hands: The Love Poetry of Pedro Salinas*. By Pedro Salinas. Ed. Tamara Alvarez-Detrell and Michael G. Paulson. *Currents in Comparative Romance Languages and Literatures*. Vol. 171. New York: Peter Lang, 2009.

Escartín Gual, Montserrat, ed. *La voz a ti debida. Razón de Amor. Largo Lamento*. By Pedro Salinas. *Letras Hispánicas* 386. 6th ed. Madrid: Cátedra, 2003.

García de la Concha, Victor, ed. *Antología comentada de la Generación del 27*. Comp. Francisco Javier Díez de Revenga. 12th ed. *Austral Poesía* 8. Madrid: Espasa Calpe, 2007.

Hi-Way Map to Zion-Bryce Canyon, Grand Canyon National Parks. Map. Utah: Utah Parks Company, 1940.

Kellough, Patrick, comp., and Dennis Rowley, ed. *A Guide to the Microfilm of the Utah Parks Company Records: Mss 533*. Archives and Manuscripts. Harold B. Lee Library. Provo: Brigham Young University, 1981.

Merleau-Ponty, Maurice. “Eye and Mind.” *The Merleau-Ponty Aesthetics Reader: Philosophy and Painting*. Ed. Galen A. Johnson. Trans. Michael B. Smith. *Northwestern University Studies in Phenomenology and Existential Philosophy*. Evanston, IL: Northwestern University Press, 1993. 121-49.

Moreno Gómez, Francisco, ed. *Generación del 27*. Madrid: McGraw, 2005.

Newman, Jean Cross. *Pedro Salinas and His Circumstance*. San Juan, PR: Inter American UP, 1983.

Salinas, Pedro. *Cartas de amor a Margarita (1912-1915)*. Ed. Solita Salinas de Marichal. *Alianza Tres* 137. Madrid: Alianza Editorial, 1984.

---. *Cartas de viaje [1912-1951]*. Ed. Enric Bou. Valencia, Sp.: Pre-Textos, 1996.

---. *La voz a ti debida. Razón de Amor. Largo Lamento*. Ed. Montserrat Escartín Gual. *Letras Hispánicas* 386. 6th ed. Madrid: Cátedra, 2003.

---. *Obras completas III: Epistolario*. Ed. Enric Bou and Andrés Soria Olmedo. Biblioteca Avrea. Madrid: Cátedra, 2007.

---. *Poesías completas*. Ed. Juan Marichal. 3rd ed. Madrid: Aguilar, 1961.

Salinas de Marichal, Solita, ed. "Presentación." *Cartas de amor a Margarita (1912-1915)*. Alianza Tres 137. Madrid: Alianza Editorial, 1984.

Silva Castro, Raúl. *Rubén Darío a los veinte años*. 2nd ed. Santiago, Chile: Editorial Andrés Bello, 1966.

Sokolowski, Robert. *Introduction to Phenomenology*. Cambridge: Cambridge University Press, 2000.

Vila Selma, José. *Pedro Salinas*. Grandes Escritores Contemporáneos 57. Madrid: ESPESA, 1972.

Waite, Thornton. "The Cedar City Branch and the Utah Parks Company." *The Streamliner*. June-Aug. 1998: 17-32.

Whitmore, Katherine Prue Reding. "La amada de Pedro Salinas." *Obras completas III: Epistolario*. Ed. Enric Bou and Andrés Soria Olmedo. Trans. Concepción Díez de evenga Ruiz. Biblioteca Avrea. Madrid: Cátedra, 2007. 1521-27.

Zorrilla, José, and Tirso de Molina. *Don Juan Tenorio / El burlador de Sevilla*. Temas de España. Vol. 4. Madrid: Taurus, 1967.

The Women in *Parzival*: An Experiment in Jungian Literary Criticism

James W. Harrison

Southern Utah University

Abstract

*This paper investigates the possibility of using Erich Neumann's schema of the feminine archetype found in his work, *The Great Mother*, as a means to compare the feminine characters in Wolfram von Eschenbach's *Parzival*. Six female figures from *Parzival* are analyzed and plotted on Neumann's schema: Herzeloyde, Ampflise, Belacane, Sigune, Cundrie, and Cundwiramurs. Each of these characters displays some characteristic of the Great Mother. Rather than occupying a discreet point on the schema, all of these characters describe a position which moves and thus describes a line on the schema. When considered together these figures describe all the features of the Great Mother. Using this technique it is possible to compare female characters with each other in a very objective way. If this technique were used with several works, one would have an objective method of comparing various female characters from different works with each other.*

One of the epistemological divides that has separated liberal arts and the physical sciences since the 17th century is the latter's penchant for empirical measurement. It is hard to argue with scientific facts. On the other hand, many see the serious study of literature, in which exact empirical measurement appears quite seldom, as being subjective to the point of caprice, particularly if they are just beginning their studies. With time this feeling will generally correct itself, but there will always be a great difference between what even a seasoned critic says about Herzloyde in Wolfram's *Parzival* and how a chemist uses the periodic chart of elements. For at least 400 years, scientific empiricism has relied on increasingly sophisticated metrics, with the outcome being that many believe if it can't be measured, it doesn't exist. This is the mantra that the West has chanted since Descartes proclaimed that "numbers are the only test of certainty" (Berman 33). The problem with this *Weltanschauung*, of course, is that the things that are most important for our humanity cannot be measured. How would one measure a Beethoven symphony or a Rilke poem? Attempting to equate being with measurability has some serious problems, but the success of the scientific method has been so obvious that these problems are often overlooked.

The goal of this paper is not to reduce literature or literary characters to measurable units. Rather, it is to investigate the possibilities of combining some of the insights of Jungian psychology and literary criticism in an attempt to clarify certain aspects of characterization, thus rendering them, to a certain extent at least, if not measurable perhaps more objective. In this paper, I will investigate whether one might establish a plane that is shared by several characters, thereby enabling the critic to compare these figures and delineate more exactly their structural roles in the narrative. Wolfram von Eschenbach's romance, *Parzival*, is well suited for this type of analysis. It includes several female figures who occupy the same narrative plane and whose characters differ from each other enough that some ordering element is necessary to compare them. Further, I will investigate whether the critic can communicate these comparisons in an abbreviated, symbolic form, thereby making them easier for the non-specialist to comprehend. These symbols may help to summarize certain aspects of the critical process in ways which more empirically oriented readers will find easier to grasp.

In his work, *The Great Mother: An Analysis of the Archetype*, a Jungian interpretation of the feminine archetype and its function in the human psyche, Erich Neumann provides a matrix that establishes just such a plane. It won't be possible in the limits of this paper to give an exhaustive account of his methods and findings; however, it is feasible

to outline enough of his argument to show its potential for this undertaking.

At the outset, Neumann states that, “the archetype of the Great Mother does not exist in space and time but in the human psyche” (Neumann 3). Consequently, it is uniquely impervious to empirical examination. Like all archetypes, this one manifests itself by determining “human behavior unconsciously but in accordance with laws and independently of the experience of the individual....” (Neumann 4). Clearly then, while this phenomenon is not empirical, it is nonetheless objective and capable of disinterested observation.

The “dynamic action of [any] archetype extends beyond unconscious instinct and continues to operate as an unconscious will that determines the personality When the unconscious content is perceived, it confronts consciousness in the symbolic form of an image” (Neumann 4f.). Neumann credits the archetype with arranging “the material of consciousness into definite patterns” (Neumann 6). It also “combines positive and negative attributes” (Neumann 7). Thus, one finds many contradictory motifs and symbols joined in the archetype. “Its nature is paradoxical....” (Neumann 12).

Since the archetype communicates symbolically, one must ultimately distinguish between the symbol as the carrier of the meaning and the meaning itself. This is a challenging task, for as Neumann states, “If one speaks of the sun and identifies it with the lion, the king, the hoard of gold guarded by the dragon, or the power that makes for the life and health of man, it is neither the one thing nor the other, but the unknown third thing that finds more or less adequate expression in all these similes, yet—to the perpetual vexation of the intellect—remains unknown and not to be fitted into a formula” (Neumann 17). The most objective symbol still tells us more about feelings than facts. These feelings lie at the core of our being and to a large extent define us as individuals and as a species.

The Great Mother archetype has two characteristics: the elementary and the transformative (Neumann 24). “As elementary character we designate the aspect of the Feminine that as the Great Round, the Great Container, tends to hold fast to everything that springs from it and to surround it like an eternal substance” (Neumann 25). The transformative character carries the dynamic element of the psyche, which, in contrast to the conservative tendency of the elementary character, drives toward motion, change, and ...transformation (Neumann 30f.). Jung referred to this aspect of the archetype as the anima. “The anima is the vehicle par excellence of the transformative character. It is the mover, the instigator of change, whose fascination drives, lures, and

encourages the male to all the adventures of the soul and spirit, of action and creation in the inner and the outward world” (Neumann 33).

In psychic development the transformative character is at first dominated by the elementary character and only gradually throws off this domination to assume its own independent form (Neumann 31). “Those women in whom the elementary character is dominant are related only collectively to their mate; they have no individual relation to him and experience only an archetypal situation in him.... The woman in whom the transformative character is dominant represents a higher, or rather later stage of development. In her the matriarchal character of the Feminine, in which the relation to the mate as well as the ego and the individual is still undeveloped, is surpassed” (Neumann 36).

“The transformative and elementary axes are not opposites. They almost always appear together but one is generally dominant” (Neumann 29). The ambiguous nature of the feminine archetype is evident in the fact that it “is not only a giver and protector of life but, as container, also holds fast and takes back” (Neumann 45). For example, the Great Mother often dominates the son and holds him fast even in his masculine movement and activity (Neumann 48).

Neumann summarizes the elementary and transformative aspects of the feminine in a schema that has at its center the elementary aspect of the feminine archetype represented as a circle (Figure 1).¹ This circle is surrounded by other circles representing other aspects of the feminine archetype. As one moves up the schema the elementary aspect gives way to a positive transformation in which the child leaves the vessel of the mother and becomes self actualized. As one moves down from the elementary aspect, one moves into the negative transformative and elementary aspect of the feminine archetype where the child is caught and imprisoned in the vessel of the mother and cannot develop. All of these circles are bisected by two axes representing the transformative and elementary characteristics of the feminine archetype. The M axis is more material and corporeal, while the A axis is more psychic and spiritual (Neumann 70). The transformative character of axis A+ is most active in the creativity of a psyche in which the receptivity of the masculine consciousness to the unconscious has become difficult and which is therefore dependent on the *anima* or transformative character (Neumann 79).

“At the negative pole of Axis A we find the alluring and seductive figures of fatal enchantment, some of which are goddesses like Astarte,

¹ This schema is based on the schema found in Neumann’s book, *The Great Mother*, as an insert between pages 82 and 83.

Aphrodite, and Artemis; some specters like Lilith, the Lorelei, and others; and some, like Circe and Medea, personalized forms of primordial goddesses. In all of them the character of enchantment leading to doom is dominant” (Neumann 80f.). At key points on the circle, Neumann has placed the name of famous mythological or religious characters that represent the features or combination of features located at a given locus of the circle. He says of this representation that it is “not to provide a dead system of co-ordinates but rather to translate the numinous dynamic of the archetypal development into quasivisual terms” (Neumann 64). While it is not empirical, it is sensual and thus seems a more accessible method of describing characterization.

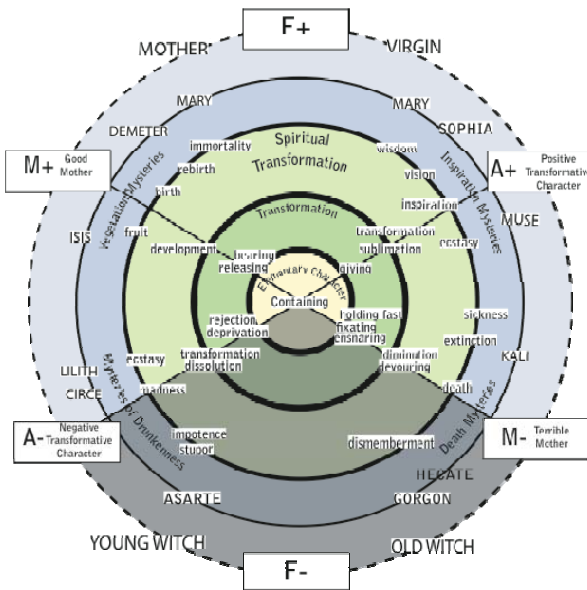

Figure 1. The Great Mother: An Analysis of the Archetype. There are two axes in this figure. The axis going from the lower left to the upper right represents the transformative principle of the Great Mother with both its negative and positive poles. Mythological and religious figures which incorporate the qualities located on this axis are listed as examples of the qualities described. The axis going from the upper left to the lower right indicates the nutritive aspects of the good mother with characters listed along the axis to serve as examples of the qualities listed. (Modified with permission from Princeton University Press.)

Neumann's emphasis in this work is on the emergence and role of various symbols, a topic that is of great interest to the study of literature. A careful consideration of characters in literary works of art and how they manifest the traits mentioned by Neumann illustrates the potential for this type of analysis. While any work of literature would suffice, in this paper, as mentioned above, I will consider Wolfram's *Parzival* and use it to delineate this type of literary criticism. While there is not time to discuss all of *Parzival's* female characters, one might turn initially to three figures who are all related to each other through the figure of Gahmuret: Herzeloide, Belacane, and Ampflise.

At the beginning of the second book of *Parzival*, Gahmuret has just come to Herzeloide's kingdom and found that she has organized a large festival. He has left his Moorish wife, Belacane, whom he won by freeing her besieged city, Patelamunt in the country of Zazamanc, from Isenhart who had laid siege because Belacane would not return his love. Gahmuret has left Africa to seek knightly adventure. The champion of Herzeloide's festival will win her hand. Gahmuret decides to participate in the festival simply because of his desire for knightly adventure. Within the space of a few pages, the reader observes Gahmuret's relationship with three different women, Belacane, Ampflize, and Herzeloide, each of whom have a claim on Gahmuret's loyalty.

There is no question that the most important of these three women is Herzeloide. Book II's primary purpose is to show how Gahmuret and Herzeloide wed and to recount *Parzival's* birth and childhood. However, as is the case with so much in *Parzival*, Wolfram doesn't order the events of this episode in an easy-to-follow chronological order. He forces his readers to recall past actions and relationships. Only then can they understand the context of any specific action.

Ampflise and Belacane

Chronologically speaking, the first of the three women mentioned above with whom Gahmuret has a relationship is Ampflize. Hans Nauman writes of her relationship to Gahmuret:

Von Ampflise hat er sein Rittertum, für sie hat er sich zum Ritter erzogen, sie ist seine wahre Herrin, ihr gilt der Deinst seiner hohen Minne.... Als sie ihn heiraten will, kann er dies um der ritterlichen Idee willen verweigern, in deren Dienste er doch für sie steht. Rittertum und Frauendienst um die Minne Ampflisens sind ihm durchaus identisch und zwingen ihn recht instruktiv zweimal, seine Ehefrau zu verlassen, nacheinander nämlich Belakanen und Herzeloiden, so innig er mit der

anderen Seite seines Wesens diese in ehelicher Liebe liebt (as quoted in Blamires 45).

He is a knight because of her. It was for her that he educated himself as a knight. She is his true mistress. It is to her that he owes his service of courtly love.... When she wants to marry him, he can refuse based on this idea of knightly behavior which has dictated his service to her. For him knighthood and the service owed Ampflise for her love are identical and force him significantly to leave his married wife twice, namely Belacane and Herzeloide, as devotedly as he has served them as their husband.

Up to this point, Ampflise has not been able to consider marriage with Gahmuret because she was already married to the King of France. But he has died, and now she is anxious to marry Gahmuret. Her words to him disclose her confidence that she and not Herzeloide will win Gahmuret as her husband. This is a confidence built on the fact that Gahmuret has served her for years already and considers her his *minneherrin* (“the object of his courtly love”). She writes him concerning her desires and says, “Moreover, you shall be my knight in the land of Waleis and before the capital city of Kanvoleis. I do not care whether the queen [i.e., Herzeloide, the Queen of Waleis] sees it; it can do me no serious harm. I am richer and more beautiful and I can more lovingly give love and receive love. If you are willing to live in accordance with worthy love, take my crown as reward” (Mustard 44; 77,8-11).² Gahmuret’s response to this statement is to return to the knightly tournament arranged by Herzeloide, his strength renewed because of Ampflise’s love. But it is important to emphasize that this love that inspires him is not the love that leads Ampflise to propose marriage. Rather, it is the love that binds him to her through *hohe mine* (“courtly love”). This conceit differs substantially from marriage and is, in fact, opposed to it (Singer vol. I 124ff., vol. II 23).

Ampflise represents the A+ axis on Neumann’s chart mentioned above. For Gahmuret, it is she who “drives toward motion, change and ...transformation” (Neumann 30).³ When we read in Book I that Gah-

² When I quote Wolfram in English, the number indicating the citation from the Mustard and Passage translation, noted as Mustard, will be followed immediately with the standard citation from Lachmann’s Middle High German edition of *Parzival* for those who wish to check the quotation in the original.

³ See above page 197

muret “had through the love of a woman’s friendship, received gifts worth a thousand marks” (Mustard 8; 12,1 f), the woman spoken of is Ampflise (Blamires 46). Gahmuret’s primary concern is *ritterschaft* (“kighthood”), which is unthinkable without a *minneherrin* (“the woman as object of courtly love”), and that is exactly what Ampflise is to Gahmuret. His relationship to her defines the concept of *hohe minne*, which is an excellent example of the A+ axis of Neumann’s schema. Here the transformative power of the feminine archetype reaches its full potential. The courtly lady becomes the knight’s muse. In Jungian terms, she is the projection of Gahmuret’s *anima*. Gahmuret says of Ampflise, “she is my real lady” (Mustard 53; 94,21), and he goes on to say how important she is to him.

One would do well to remember when speaking of the *anima* that Neumann believes it to be the link between the masculine consciousness and the unconscious. When the masculine conscious mind has developed to the point where it is no longer aware of the unconscious, it is the *anima* that enables that communication to take place (Neumann 78). This communication is sometimes so complete that the person who projects this *anima* sees himself as identical with it.

Knights frequently identify themselves as being a part of, or identical with, their lady. Consider, for example, in Book I Belacane’s relationship to Gahmuret after they have both been taken by their feelings for each other. As Gahmuret leaves the Queen, she gives him a departing drink: The Mustard and Passage translation of this passage is unfortunate for the purposes of this paper. They translate as follows: “Then she ordered them to pour the parting wine cup. That she would have left undone if she had dared, and it vexed her that it could not be left undone, because it always drove the knights away who liked talking to women. Yet she was now his, and he had given her the feeling that his life was now the lady’s life” (Mustard 18; 29,9-16). The words “yet she was now his” translate the Middle High German “*doch was ir lip sin selbes lip*,” which says literally, “yet her life (or body) was his own life (or body).” The words “his life was now the lady’s life” translate the Middle High German “*sin leben was der frouwen lebn*.” *lip* and *leben* can both mean life, but *leben* can only mean life. It would seem that Wolfram in using *lip* twice in the beginning of this sentence and *leben* or *lebn* at the end of the sentence is drawing attention to the fact that *lip* is to be understood as body. I would therefore suggest the following translation of the sentence: “Yet her body was his own body; his life was the woman’s life.” This is the *anima* at work. There is a

one-for-one identification between the knight and his soon-to-be mistress.⁴

As long as Gahmuret is allowed to serve Ampflise in the context of *hohe minne* (“courtly love”), he can remain true to the ideal of *ritterschaft* (“knighthood”) even if he is married to someone else. However, now that the King of France has died, Ampflise wants to change her relationship to Gahmuret. Instead of the transformative influence in his life she has been up to this point, she now wants to exert an elementary influence. We see her slide down the A+ axis toward the center of the elementary character (see Figure 2a). Gahmuret will have nothing to do with this and continues to serve the memory of what Ampflise was to him even after his marriage to Herzloyde, just as he did after his marriage to Belacane. It is while he is serving this memory that he dies in battle. Even though (or better, because) Gahmuret does not accept Ampflise’s offer of marriage, he remains true to her throughout his life. The roles of *minneherrin* and wife cannot be filled by the same person, because they are on opposing axes of the schema.

The next woman who becomes a major influence in Gahmuret’s life is Belacane. To understand her influence on Gahmuret in Book II and, therefore, her placement on the schema, one must know of their relationship in Book I. Gahmuret leaves his home in France to seek his fortune as a knight abroad, as explained above. He enters the employ of the Baruch of Baghdad and becomes famous throughout Arabic lands as a model knight. As he is traveling by boat, a fierce storm drives him to Patlamunt, the capitol of Zazamanc, where the kinsmen of Isenhart are besieging Belacane. Gahmuret’s arrival in this North African city on the shores of the Mediterranean is an obvious reference to Aeneas. Aeneas also arrives in Africa after being driven off course by a storm and, upon landing, meets Dido, lives with her, and then leaves her to find another wife in Europe. This same series of events will play itself out with Gahmuret and Belacane.

After Gahmuret has landed at Patlamunt, he is told of Belacane’s plight and offers her his assistance. Wolfram does his best to empha-

⁴This projection of the anima, which is so powerful that it combines the identity of two people, is hardly unique to any period of literature. One thinks, for example, of the scene in *Wuthering Heights* where Catharine says concerning Heathcliff, “I am Heathcliff” (Brontë 175) or in Wagner’s *Götterdämmerung* where Siegfried says to Brünnhilde, “Durch deine Tugend allein/so soll ich Taten noch wirken?/ Meine Kämpfe kiesest du, meine Siege kehren zu dir:/ auf deines Rosses Rücken,/ in deines Schildes Schirm,/ nicht Siegfried acht’ ich mich mehr,/ ich bin nur Brünnhildes Arm.” (Wagner 32) “Through thy virtue alone shall I perform deeds? Thou wilt choose my battles, my victories will turn to thee; on thy horses back, protected by thy shield, I shall not consider myself Siegfried any longer, I am only Brünnhildes arm.”

size the courtly splendor of Belacane’s court. She is smitten by Gahmuret when she first sees him. Belacane has “a woman’s manor” and “was on other counts worthy of a knight” (Mustard 14; 24,8f.).

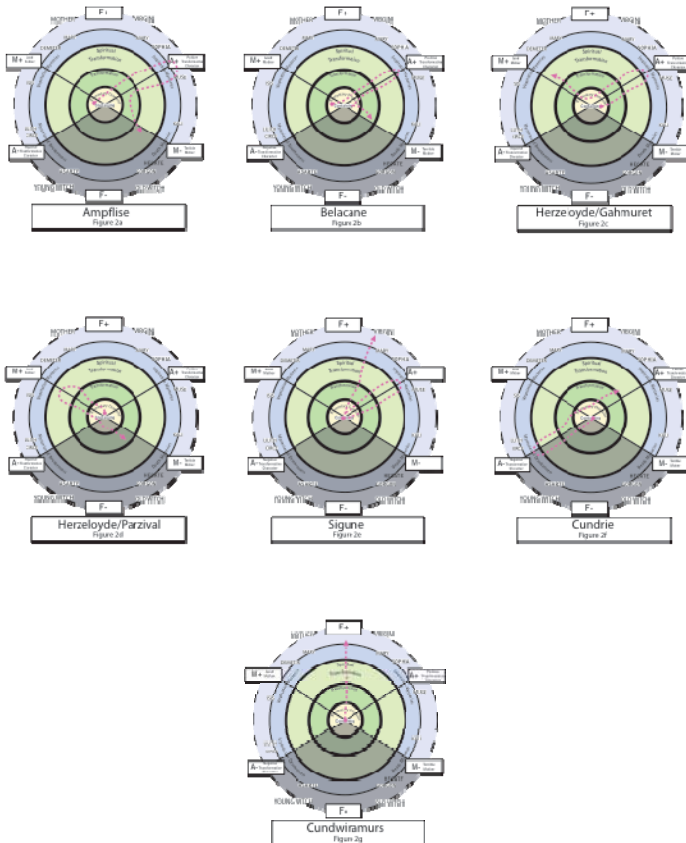

Figure 2. (A) This schema plots the path taken by Ampflise as charted on the Great Mother Archetype. (B) This schema plots the path taken by Belacane as charted on the Great Mother Archetype. (C) This schema plots the path taken by Herzeoyde on the Great Mother Archetype as she woos and marries Gahmuret. Throughout this experience her path is in the positive part of the schema (F+). (D) This schema plots Herzeoyde’s path on the Great Mother Archetype as Parzival’s mother. Throughout this experience her path while beginning in positive territory (F+) also moves into negative territory (F-). (E) This schema plots Sigune’s path as charted on the Great Mother Archetype. (F)

This schema plots Cundrie's path as charted on the Great Mother Archetype.
 (G) This schema plots Cundwiramurs path as charted on the Great Mother Archetype.

There is only one problem and that is that "her complexion was black of hue" (Mustard 14; 24,11). Wolfram calls attention to this fact more than once. Belacane is aware that this issue might be a problem. When her marshal brings the news that a hero has found his way to Patelemunt, she says, "He is of a different color from us. O, I do hope he won't be offended by that" (Mustard 13; 22, 8f.). Wolfram introduces Belacane by saying, "If there is anything brighter than daylight—the queen in no way resembled it" (Mustard 24; 24, 6f.). This description is meant, among other things, to contrast Belacane with Herzeloide. When describing the latter, Wolfram says, "From the lady Herzeloide was shed such radiance that, if all the candles had been extinguished, there would from her alone have been sufficient light." (MP 48)(84,13). The issue of brightness and darkness will be dealt with below, but for now it is safe to say that even though Belacane is "of black hue," Wolfram makes it clear that she lacks nothing that would distinguish her as a courtly lady.

As Belacane and Gahmuret speak and he inquires concerning her relationship with Isenhart, Wolfram makes clear that she is as perfect a courtly lady as any in Europe. The issue of religion Wolfram settles by saying that "her innocence was a pure baptism" (Mustard 17; 28, 14). It is at this point that the scene discussed above occurs in which Gahmuret and Belacane merge, figuratively speaking, into one person. A sure sign, as already mentioned, that she has become his anima.

After a dinner at which Belacane spares no expense to please Gahmuret and his retinue, the hero retires and has trouble sleeping because of his love for Belacane. In the morning he takes the field against the queen's enemies. Wolfram states succinctly, "his service was for love's reward, and a sharp fight weighed lightly with him" (Mustard 22; 37, 8f.). After the battle it is Belacane herself who leads the victorious Gahmuret through the city, removes his armor, and beds him. When he speaks with his cousin, Kaylet, concerning Belacane, he states, "the queen took me captive with her own hand, and with love I defended myself, for my wits so counseled me" (Mustard 28; 49, 22f.).

Gahmuret and Belacane marry, and with that their relationship changes from one in which she serves as his anima to one in which she is seen as the opposite of the force that impels him to seek adventure. Eventually, "he found no knightly activity, and then his joy was pawned to sorrow" (Mustard 31; 54, 17-20). He mentions this later in

Book II. There he says, “the lady’s protectiveness held a tight bit on me, so that I could not get to knightly action, and then I fancied that knightly action would rid me of the bonds of discontent” (Mustard 51; 90,29-91,2). He leaves secretly at night leaving behind a note that assures Belacane of his love for her and that she might win him back if she were to convert to Christianity, a request she would gladly fulfill but never gets the chance to do.

We move now to Book II where it is Belacane’s memory rather than her person that affects Gahmuret. The first mention of her occurs when Gahmuret’s servants are putting up his tent before the field where Herzeloide’s festival is being held. We hear that this tent was lost by Isenhart, the man driven by unrequited love for Belacane (Mustard 35; 61,9). The fact that the tent was so large that it required thirty pack horses to transport it reminds us that this suitor for Belacane was a wealthy, powerful individual. That he could be so overcome by love for Belacane is tacit evidence of her beauty and nobility.

The next and most important mention of Belacane in Book II occurs when Gahmuret who has fought the entire day in the festival at Kanvoleis receives the news of his brother’s death. He is so overcome by grief that he cannot continue with the festival even though he is the clear champion. He is also overcome by his desire to be with Belacane: “I yearn for the queen. I left in Patelamunt a sweet woman of purest kind, and my heart is sore because of it. Her noble dignity compels me to sorrow for her love.... Lady Belacane robs me of manly gladness....” (Mustard 51). These two griefs, his sorrow for Belacane and for his brother’s death, he takes with him as he retires.

When plotting Ampflise and Belacane on Neumann’s schema, the paths their characters describe are similar (Figure 2a and b). Initially, both of them are on the A+ axis. They both have a positive transformative effect on Gawan. As shown above, Ampflise compromises this influence when she proposes marriage. Belacane compromises it in the same way, with the difference that she really does marry Gahmuret. It would seem then that the problem here is marriage. The A+ axis seems to be able to function only in the absence of marriage. Once a hero and his lover marry, the woman slips down the A+ axis and begins her descent on either the A- or the M- axis. But as we will see later on when considering Cundwiramurs, it only *seems* this way.

Herzeloide

The morning after Gahmuret’s great sorrow, as just described, Herzeloide comes to press her claim on Gahmuret. He has won the tournament and must therefore take her as his prize, but Gahmuret is

unwilling. His first excuse is that he is already married: "Lady, I have a wife," [i.e., Belacane] "dearer to me than I am to myself..." (Mustard 53; 94, 5f.). Herzeloide will not hear of this and says, "You should renounce the Moorish woman for my love's sake. The sacrament of baptism has superior power" (Mustard 53; 94, 11-13). Gahmuret's next excuse is his relationship with Ampflise as discussed above. His third excuse is that while he understands that Herzeloide should be given to the champion of the tournament, the tournament never took place. He points out that the vesper games in which he had been fighting all day were a prelude to the tournament. These games have so exhausted the armies that no one can continue with the tournament itself. Since there will be no tournament, there will be no champion of the tournament, and she cannot press her claim.

Finally a judge is called in to adjudicate concerning Herzeloide's claims on Gahmuret. The verdict is then given in Herzeloide's favor. Ultimately, it is "the fairy strain" in him, aided by the fact that all of this takes place in the Spring, that moves Gahmuret to love Herzeloide (Mustard and Passage 54; 96, 20). But even as he surrenders to her, he says that he must be allowed one tournament a month. His inspiration in these tournaments will be Ampflise as discussed above.

Initially, Herzeloide's relationship with Gahmuret seems to be cast in the same mold as Belacane's and Ampflise's. She seems to inspire Gahmuret, though not to the degree that Ampflise does. Whether she will provide the domestic comforts for Gahmuret that Belacane did is a moot point, because we never see or hear Gahmuret and Herzeloide in anything like a domestic scene, but we have no reason to believe that she would be incapable of, or averse to, this type of behavior. That she is potentially a courtly heroine cannot be doubted. Wolfram identifies her initially as a maiden, not a woman (Mustard 35; 60,15); that is, she is at that point in her life when knights fight for her honor and to win her hand in marriage. She can function in the role of *anima*.

One of the most interesting aspects of Herzeloide mentioned above is the light symbolism Wolfram employs to describe her. "From the lady Herzeloide was shed such radiance that, if all the candles had been extinguished, there would from her alone have been sufficient light" (Mustard 48; 84,13). Neumann shows the importance of this light symbolism in determining the valence of the feminine archetype. According to him, "bearing and releasing belong to the positive side of the elementary character; their typical symbol is the vegetation symbol, in which the plant bursts out of the dark womb of the earth and sees 'the light of the world.' This release from the darkness to the light characterizes the way of life and also the way of consciousness" (Neu-

mann 65). Some pages later he says, “the rise of consciousness from the unconscious has been glimpsed as the central factor in human history as a whole.... The tendency toward the light, which C.G. Jung once called human heliotropism, has in the long run proved stronger than all the forces of darkness that have striven to extinguish consciousness” (Neumann 90).⁵

Herzeloide begins her role in Parzival on the A+ axis and then, like Belacane and Amplise, instead of pursuing her role as Gahmuret’s muse she turns back on herself, moves away from the A+ pole of the A axis, and slides down to the center, the point where the transformative and nutritive aspects merge (Figure 2c). In doing so she leaves the conceit of courtly love behind her just as Belacane and Ampflise do in favor of the nutritive aspect of the Great Mother. The difference between Herzeloide and the other two female characters discussed thus far is that she turns away from courtly life and knowingly changes from muse to mother. She is the first character thus far to occupy the M axis.

This maternal element expresses itself first not with her son, Parzival, but with her husband, Gahmuret. Wolfram makes this clear when he has Herzeloide, who is lamenting her husband’s death, say, “I was much younger than he, yet I am both his mother and his wife. I bear him here within me and also the seed of his life which our two loves gave and received...” (Mustard 62; 109, 24-27). Herzeloide’s role as Gahmuret’s *anima*, by means of which she bears and nourishes his heroism and inspires his knightly deeds on the transformative axis, is now expressed on the elemental axis. In this highly instructive scene, the closeness of the transformative and elemental aspects of the feminine archetype becomes obvious. And so we pass from Herzeloide as wife to Herzeloide as mother.

Herzeloide’s role as Parzival’s mother is marked at the outset by her renunciation of the court. She wants to insure that the *rittershaft* (“knighthood”) that led to her husband’s death will never disturb her son. In rejecting this she must also reject the *hohe minne* (“courtly love”), which cannot exist without *rittershaft*. The other obvious fact about Herzeloide’s relationship to her son at this point is her determination to keep him close to her. One is reminded of Neumann’s words in describing the negative aspects of the Great Mother: “But the ele-

⁵Concerning this heliotropism, I cannot let the opportunity pass by to remind the reader of the great scene in Faust I, 1349ff. “Ich bin ein Teil des Teils, der anfangs alles war./Ein Teil der Finsternis, die sich das Licht gebar./ Das stolze Licht, das nun der Mutter Nacht/ Den alten Rang, den Raum ihr streitig macht....” I am a part of that part that in the beginning was everything, a part of the darkness that gave birth to light, the proud light that now contests mother night’s status and space.

mentary character of the Archetypal Feminine is far from containing only positive features. Just as the Great Mother can be terrible as well as good, so the Archetypal Feminine is not only a giver and protector of life but, as container, also holds fast and takes back;..." (Neumann 45). This explains Herzeloide's relationship with the young Parzival. She tries to prevent his development. Her role as the protecting vessel for Parzival changes into an ensnaring hindrance and drags Parzival away from his preordained fate. When she can no longer absorb him into her, she dies; this allows him to escape the effects of the M- pole of the elementary axis (Figure 2d). Although she does not completely frustrate his journey to his ultimate destiny, she does slow it down. It is her influence as much as anything that is responsible for him being a slow learner at court and throughout the first part of his journey.

After Parzival leaves his mother and begins his journey of self-actualization, his adventures are marked by the various women he meets, among whom Sigune, Cundrie, and Cundwiramurs are some of the most important. Each of these characters can be plotted on Neumann's schema. When this is done, one can see a pattern developing with regard to how these characters are charted.

Sigune

Beginning with Sigune, we see a figure whose influence on Parzival is almost exclusively on the A+ axis. Sigune is always an index of what Parzival has accomplished or failed to accomplish (Blamires, 174). She is an unerring advisor to Parzival and can discern his circumstance at all times (Blamires 175). The importance that Wolfram attaches to this character is obvious from the fact that he has greatly expanded her role from the same character in his source, Chretien de Troye's *Percival*. Chretien leaves this figure unnamed in his work, where she meets Parzival only twice. Wolfram's Sigune encounters Parzival four times. She also becomes the primary female character in Wolfram's *Titurel*. Clearly, she is a figure of some importance for Wolfram and deserves careful attention.

She teaches Parzival by precept and example about *leit* ("sorrow") and *triuwe* ("loyalty") (Blamires 174). On all four occasions when she and Parzival meet, she is in the company of her fallen lover and therefore comes to symbolize *minne* ("courtly love"). The religious atmosphere evoked by her character and circumstances elevates that *minne* from the purely secular to the religious sphere, thus helping to prepare Parzival for his future life in the Grail society and at the same time making a statement about Wolfram's concept of courtly love, which is often at variance with the standard view of the court (Blamires 174).

This same religious atmosphere and the moral earnestness that it invokes highlight Sigune's moral excellence, which is the source of her ability to pass judgment on and ultimately pardon Parzival (Blamires 175).

Parzival's first meeting with Sigune occurs soon after his first episode with Jeschute, the first woman other than his mother that he meets. It is Jeschute's lover, Orilus, who has killed Sigune's beloved, Schionatulander. By doing penance, Sigune hopes to expiate the guilt she feels because of this knight's death. She waited too long to grant her *minne* ("courtly love") to Schionatulander. Parzival pities Sigune when he hears her story. His first thought is to find the knight who killed Sigune's love and avenge her loss. This offers us an important insight into Parzival's character. While he is yet naïve and untutored, he is still capable of feeling genuine *riuwe* (remorse) (Mustard 178; 140,2), which is a sign of his *triuwe* ("fidelity") (Mustard 178; 140,1). Sigune compliments Parzival on these virtues and then asks his name. He says that his mother always called him *bon fils, cher fils, beau fils* ("good son, dear son, beautiful son") (Mustard 78; 140,6). When she hears this response, she recognizes with whom she is speaking. Sigune was raised by Herzeloide, Parzival's mother, after her mother, Schoysiane, died. Having been a member of Herzeloide's household, she heard these names frequently when Herzeloide used them to address her son. She informs him of his true name, Parzival, along with its etymology, "right through the middle" (Mustard 78; 140, 17). She goes on to inform Parzival of his ancestry, of the fact that he is the King of Norgals, and that her dead lover had been protecting Parzival's lands when he was killed. She further informs Parzival that Orilus and Orilus's brother, Lehelin, have done Parzival much harm.

It is interesting to note that in Chretien's poem, Parzival guesses his own name, not knowing whether he is right or wrong, and his identity is not made explicit until after his visit to the Grail castle (Blamires 177). Wolfram, however, underlines the transformative influence of Sigune on Parzival by allowing her to give Parzival his identity, thus identifying her once more with the A+ axis of Neumann's schema.

Parzival's second meeting with Sigune occurs immediately after his departure from the Grail castle. Both characters have changed. Parzival has failed to ask the all-important question. Since he cannot grasp the significance of that act yet, Sigune must help him to comprehend it. She has moved from the forest of Brizljan to the Grail forest. This change of venue indicates a change in the plane of action. Both characters have moved further away from courtly society (Blamires 179), and their deeds have assumed a greater religious significance. For Parzival, this scene will begin a new and important part of his jour-

ney. Wolfram draws attention to this when he says, “alrerst nu aventi-urt ez sich,” “His adventures begin now in earnest” (Mustard 135; 249,4).

Sigune’s primary virtue, her *triuwe* (“fidelity”), which might also be translated either as her loyalty or compassion, is immediately obvious. As in the other scenes where she meets Parzival, one has the feeling that one is looking at a still life. The constancy of her *triuwe* adds to this impression. She remains as we first see her throughout the scene. Parzival comes and leaves, but Sigune never changes her position. She holds her dead, embalmed lover in her lap. The resemblance to a *pieta* is unavoidable. It is worth remembering that the word *pieta* comes from the Latin *pietas*, which along with *dignitas* and *gravitas* were the primary virtues of a noble Roman. *Pietas* represented adherence to duty, which Sigune incarnates in this scene. Wolfram says that all earthy loyalty is like a fleeting breeze when weighed against the constancy one sees in her (Mustard 135f.;249, 24f.). As important as this virtue is, Sigune and Parzival seem to hold disparate views concerning it (Blamires 179f.). For Sigune it is based on compassion. For Parzival it subsumes his relationship with God and man. It is an expression of compassion and love (Blamires 181).

While the ambiguity that arises from the difference between potential *triuwe*, which Parzival possesses, and actual *triuwe*, which is lacking in his relationship with Anfortas (Blamires 181), won’t be worked out until Book IX, the important point in this scene is that Sigune is again cast as Parzival’s mentor. Once more we see her acting as a symbol of the A+ axis. She tells Parzival a great deal concerning the Grail society, how it came to be, and who belongs to it. She predicts a bright future for Parzival as Grail King. But then she finds out that Parzival did not ask Anfortas the all-important question when he visited the Grail castle; that is, he did not ask Anfortas why he was suffering.

Her estimation of Parzival now changes completely, much to Parzival’s dismay. He asks how he can atone for his failure at the Grail castle. Sigune’s response is, “you can spare yourself the atonement.... I know well that you lost your honor and your knightly fame at Munsalvaesche. You will get no other answer from me” (Mustard 139; 255,24-29). Parzival leaves her at this point confused and depressed, in the belief that he will never be able to recover from his blunder.

This last episode deserves some attention with regards to Sigune’s movement along the A+ axis. Some of the reasons for locating her on this axis have been mentioned already. As we have seen in Parzival’s first encounter with her, she gives Parzival his identity. She moves him along the path of wisdom. She also helps Parzival understand the Grail

society and how he is to fit into that society. There are other reasons to place Sigune on this axis. If one looks at the top of the schema, one sees that the virgin is just to the right of the F+, signifying the first real difference between the M and A axes of the feminine. It is, of course, Sigune's fate to be a virgin. This focuses her role as the muse of inspiration as opposed to the nurturing mother.

However, Sigune is much more than an archetype. As helpful as an archetypal approach can be to literary figures, there is always the danger of seeing the archetype rather than the figure itself as the end and trying to force the figure into a preconceived mold. This obfuscates rather than clarifies the figure's character. Sigune is not just an idea or a projection of a psychological state, but a human being. Therefore her character is in some respects ambivalent. While the preponderance of her actions places her on the A+ axis, there are other aspects of her behavior that suggest qualities of the M axis (Figure 2e). One of the characteristics of that axis is its conservative nature. The M axis encourages growth, but that growth must occur in a set environment, an environment controlled by the Great Mother. If something happens to that environment, the offending party can no longer be a part of it. This quality is not the same as the grasping mother who holds fast and ensnares, but some of the consequences are often the same as if it were. Sigune encourages Parzival and predicts a bright future for him only until she finds that he has not asked the question. When she discovers his error, she cannot see a way around it. This conservatism appears to destroy the bright future which she just foresaw. While Sigune's character is fundamentally a positive one, here it is not. She must find a way around this impediment if she is to remain a marker of the A+ axis for Parzival.

Another problem Sigune must deal with in this regard is the fact that she never returned her lover's love while he was alive, a fact she freely admits (Mustard 79; 141,20 f.). Sigune's devotion to the conservative demands of chastity incorporated in the conceit of courtly love deprived her of the love relationship for which she yearned. It also denied Schionatulander the opportunity of progressing along his path as a courtly knight and may have hastened his untimely death. The exact circumstances surrounding Schionatulander's death are unclear, but there seem to be reasons to suspect it was involved with his unrequited love of Sigune. If this is in fact the case it would place Sigune in this relationship on the negative M axis. She ensnares Schionatulander in a relationship that is a dead end. On the other hand, had she not done this she would not have become the virgin lover that she is at the end of her life and would therefore have sacrificed much of her symbolic authority as we shall see later on.

The third meeting of Parzival and Sigune occurs just before Parzival's meeting with Trevrizent in Book IX. There is general agreement that this meeting with Trevrizent is the climax of Parzival's education and that Parzival has everything he needs to realize his destiny as the Grail King when he leaves Trevrizent. Therefore, Sigune's meeting with Parzival just prior to this meeting is of utmost importance. Her first two meetings with Parzival have followed important events in his life, the first, the embarrassing episode with Jeschute, in which he has his first experience with the world of women after he leaves home, and the second, his even more unsuccessful encounter with the Grail society. The third meeting with Sigune does not follow but precedes the all-important meeting with Trevrizent in which he will finally see his destiny clearly.

Again there is an intensification of the religious atmosphere. Sigune is portrayed as a hermit (Blamires 183). However, she is wearing a ring. When Parzival asks about the ring because anchorites do not involve themselves in romantic relationships, Sigune answers that the ring symbolizes her pure devotion to Schionatulander. In commenting on this scene Blamires says: "...what Sigune stands for is not purely religious, but a fusion of the worldly with the religious" (Blamires 183). I agree with him. The dualism of the spiritual and the worldly, of *agape* and *eros*, begins to fade here. In this meeting, Sigune's love has lost all of its worldly aspects. Sigune's devotion to Schionatulander throughout Wolfram's work suggests that the author felt the *unio mystica*, which was one of the pillars of courtly love (Singer, Vol. II 31), finally had found its realization. Sigune's love for God and for Schionatulander merge in this scene (Mustard 234; 435,13-15). Her *triuwe* ("fidelity), which defines her relationship to Schionatulander, she also offers to God, thereby combining these two loves in a virtue that is both spiritual and secular but seems to surpass both. In overcoming the duality of world and spirit, Sigune synthesizes the two into a third quality that represents the result of the courtly love tradition as it works itself out in Wolfram. As Blamires says, "*Triuwe*, in this episode, has become quite definitely more than merely the basis of compassion: it is now the foremost expression of love for God, in which love for one's fellow man is included" (Blamires 184).

At this point where *minne* and *triuwe* converge, Parzival and Sigune are united in *leit* (sorrow)—she for her fallen lover, and he for his wife. She has yearned for God, and he for the Grail (Blamires 184). The growth that both have experienced because of their respective quests now unites them. Sigune, who in the past has received Parzival's compassion, now offers hers to him. She withdraws her censure of him (Mustard 237f.; 441, 18f.) and puts him on the path to find

Trevrizent, their mutual uncle. Parzival asks advice of her now, “*liebiu niftel, gip mir rat,*” “dear cousin, advise me” (Mustard 238; 442.1 ff.) in a statement that in its simplicity and directness is reminiscent of the question he will ultimately ask his uncle. Her act of rescinding her harsh judgment of Parzival is all the more important because she has been in close contact with Cundrie, who cursed Parzival in Arthur’s court. Her forgiveness foreshadows Cundrie’s forgiveness later. So this entire scene can be viewed as a prelude to the final denouement when Parzival finally establishes himself as the King of the Grail. After her censuring of Parzival, Sigune’s actions in this third meeting clearly reestablish her squarely on the A+ axis of the chart.

The fourth and final meeting between Parzival and Sigune occurs on Parzival’s own initiative (Blamires 188). The previous three episodes with Sigune have been chance meetings, but here Parzival actively seeks out his cousin. When he finds her she has died, sealing her devotion (*triuwe*) to her fallen lover with her death. She has finally achieved a perfect union with Schionatulander. Although she is dead, her body is still in the posture of prayer. This confirms the close union between spiritual and earthly love mentioned above and secures her a permanent place on the A+ axis. Parzival sees to it that Sigune’s body is placed next to her lover’s body and then closes the grave where both have been laid to rest.

Cundrie

Cundrie is one of three characters in Wolfram’s work who curses Parzival. The other two are Sigune, as mentioned above, and the servant at the Grail castle. She is unique in Wolfram’s work because of her description. While the superlatives used in describing the other female characters are general terms of praise one associates with women of the court, Cundrie’s description is as specific as it is horrific.

We first hear of her intellectual accomplishments, which are considerable. She is fluent in French, Latin, and Arabic. She has been trained in dialectic, geometry, and astronomy; that is, she has studied both the trivium and the quadrivium. We also hear of her elegant dress. But whereas courtly ladies instill joy at court, she “struck down great rejoicing” (Mustard 169; 312, 30). Her physical appearance indicates something is terribly wrong. Her hair is “black and hard, not pretty, and soft as the bristles of a pig. She had a nose like a dog’s, and two boar’s teeth stuck out from her mouth, each a span in length. Both eyebrows were braided and the braids drawn up to the ribbon that held her hair. . . . Cundrie had ears like a bear’s, and no lover could desire a face like hers, hairy and rough.” Her hands “looked like a monkey’s

skin. Her fingernails were none too fine, and...they stuck out like a lion's claw. Rarely was a joust fought for her love" (Mustard 169; 313, 18-25, 29ff.). A quick look at Neumann's schema is enough to place this character in the lower half along with other negative feminine characters from mythology whose appearance is witness of their disruptive influence (Figure 2f). The witches and Gorgons both are hideous beings who represent death and dismemberment. The difficulty with Cundrie stems from the fact that she is without question a representative of the Grail. How can a member of the Grail society be portrayed in this way? The only plausible answer is that there is something wrong in the Grail society itself beyond the fact that its king, Anfortas, is ill.

To confirm this theory it will help to point out that while the Grail society has a king, it has no queen. Anfortas, whose spouse was supposed to fill that role, made some bad mistakes in his choice of women and in the process was wounded with a wound that only Parzival will be able to heal. Not coincidentally, Parzival will also provide the Grail society with a queen. Only after he does both these things will the Grail society fulfill its proper function. It is a woman who symbolizes that the society is faulty; it is a woman who will help restore the proper balance there.

Cundrie's chiding of Parzival reveals that she sees the question that Parzival neglected to ask the same way Sigune does; that is, as a question of compassion (Blamires 347); however, her vehemence in attacking Parzival at Arthur's court indicates that there is more at stake here than Parzival's standing with the Grail society. She views Parzival's failure as threatening the very being of the knightly Arthurian society to which Parzival belongs (Blamires 348). Cundrie's attack is not limited to Parzival's lack of compassion. She also berates him for his lack of manly honor (Mustard 171; 316, 13) and knightly virtue (Mustard 171; 316, 14). She believes his faults are systemic and that he has squandered any chance he may have had for salvation, saying that he is destined for hell (Mustard 171; 316, 11). Here again she agrees with Sigune. She compares him unfavorably with both his brother, Feirefiz, and his father, Gahmuret (Mustard 171; 317, 8ff.).

This is the conservative negative M axis trying to protect that which is reassuring and familiar. It is the same reaction, though much more violent, that we noticed above when Sigune chided Parzival in their second encounter.

In discussing this scene, Blamires points out the interesting fact that while Cundrie is addressing matters that pertain only to the Grail society, she is doing it not in that society but at Arthur's court. The court itself is completely passive and takes no stand concerning Par-

zival or Gawan, whom Cundrie also criticizes. Parzival's decision to leave the court is his own and is neither ratified nor contradicted by Arthur's court (Blamires 149).

Cundwiramurs

If one of the defining characteristics of Cundrie is her explicit ugliness, then one of Cundwiramurs's is her beauty. Wolfram is not given to excess in describing this beauty. His technique in describing Cundwiramurs is rather oblique. He describes the beauty of Jeschute carefully and then says concerning Cundwiramurs that she was even more beautiful than Jeschute (Blamires 219). As is the case in all medieval romances, the exterior always indicates the quality of the person's interior. We know from the beginning then that Cundwiramurs will occupy the positive area of both axes. The question here is which of the axes predominates, the M or the A. Sigune and Cundrie are closer to the A axis. Cundwiramurs's character, however, will include more of the M axis, not just because she is the mother of Parzival's sons, Hardeiz and Loherangrin, but because of the role she occupies in Parzival's development (Figure 2g).

Cundwiramurs is not the first woman Parzival has loved. Gurnemanz's daughter, Liaze, attracted him to such a degree that upon leaving Gurnemanz he promised to marry Liaze when he felt he had sufficiently distinguished himself as a knight. As is so often the case in Wolfram, fate contrives to associate two characters with each other, in this case Liaze and Cundwiramurs, who at first seem unrelated. Gurnemanz is Cundwiramurs's maternal uncle. Liaze's brother, Schentaflurs, sought to help Cundwiramurs against Clamide who was trying to force her into marriage. In the process, Schentaflurs was killed in a war that is still raging when Parzival arrives in Cundwiramurs's kingdom of Pelrapeire. By defeating Clamide, Parzival wins Cundwiramurs. The sequence of events that leads to this victory and subsequent marriage is an interesting chapter in Parzival's life and tells us a much about Cundwiramurs, how Wolfram perceived her character, and how he conceived the marriage relationship between the future Grail King and Queen.

After she welcomes Parzival into her castle and provides what meager fare she can because of the famine her castle is experiencing, Parzival retires. It is Cundwiramurs who comes to him that night. She initiates their first private contact. Wolfram is anxious to confirm that, "the proper limits of womanhood were not broken" (Mustard 105; 192,2). The extremities that her besieged city now endure are the motive force behind this visit to Parzival. Wolfram again emphasizes that

her visit has nothing to do with any romantic inclinations, "...she came now, not for such love as gains the name of changing maids to women, but for help and a friend's advice" (Mustard 105; 192,9). Chretien, Wolfram's source, strongly suggests a certain amount of sexual dalliance in this meeting, but Wolfram insists that both Parzival and Cundwiramurs were totally innocent of any amatory desires (Blamires 235). She is there solely to implore Parzival's aid against Clamide so that she may save her town. While Wolfram is quite explicit that Cundwiramurs gets into bed with Parzival while he is still asleep, he for the third time assures his audience that the two do no more than talk while they are in bed together. When Cundwiramurs wakes Parzival, she says that she will tell him what she desires to say only if he will show such restraint that he not "wrestle" with her (Mustard 106; 194,1). She explains the problem with Clamide and Kingrun, his seneschal, who are both trying to force her into a marriage with Clamide. Parzival agrees to fight Kingrun the next day. He defeats him, and when he returns to the Cundwiramurs and her joyful people, Cundwiramurs embraces him and says that she shall never marry any man but the one she has just embraced. The two spend the next two days and three nights together "happy with each other in their affection" (Mustard 110; 203,1). Then Parzival must complete the victory that he began by defeating Kingrun. He defeats Clamide and charges him, as he did Kingrun, to go to Cunneware, a lady at Arthur's court, to pledge her his allegiance and assure her that Parzival was still fighting for her.

At the end of Book IV, Wolfram assures us that the love between Cundwiramurs and Parzival "stood in such strength that no wavering could affect it" (Mustard 120; 223,2f.). Concerning Cundwiramurs's feelings for Parzival when he asks that he be allowed to go see how things fare with his mother, the text says, "He was dear to her...and she had no desire to deny him" (Mustard 121; 223, 27f.). This is the last direct reference we have of Cundwiramurs until Book XVI. She is mentioned in passing in Book XII, when Ogeluse offers Parzival her lands and herself (Mustard 326; 619,3). Parzival declines and says that he has a more beautiful wife whom he prefers to her (Mustard 326; 619, 4f.). It is clear from this encounter that Parzival is not only sure of Cundwiramurs's love for him, but even more importantly of his love for her.

There is, however, one problem with their love that Parzival feels acutely. As we approach the end of the work, Parzival has been away from his wife for several years. He says, "I parted from her—too long ago" (Mustard 382; 732,22). In his despondency over their long separation, he considers taking another lover, but quickly sees that his love for Cundwiramurs is so strong that he cannot even consider such a

thing and then gives himself up to the sorrow of loving her but being without her. He states that those who are fortunate enough to have found love and have it with them at present are blessed but that he is not in their number. He concludes by deciding to do without love, “From these joys I shall depart.” (Mustard 382; 733,20). It might be noted parenthetically that these words bear a striking resemblance to Gottfried’s words at the beginning of *Tristan* when he says that those who don’t understand the true nature of love are welcome to their joys but that his way and theirs diverge sharply. Wolfram says, *got gebe freude al diesen sharn*, (“May God bestow joy on all these hosts”) (Mustard 382; 733,19), while Gottfried records, *die laze ouch got mit fröuden leben* (“may God let them live with joy”) (Gottfried 54).⁶

The intent is similar in both passages. Gottfried believes that those who are not of the *edlen herzen* (“noble hearts”) will never understand the love Tristan and Isolde feel for each other. Wolfram also indicates that the love Parzival feels for Cundwiramurs is not an option for others. It turns out that they are both correct. It is clear that Gottfried’s hero and heroine respond to a different amatory ethic than the courtly love conceit as it was commonly practiced in his day. It is just as clear that Wolfram’s hero cannot go along with the courtly display of his day. His destiny is different from theirs. The future Grail King must be held to other standards. And those standards, of course, have to do with the Grail. That must be Parzival’s primary concern, not his love for his wife. That is where Anfortas made his mistake. Carl Wesle writes well concerning the earthly love that Parzival feels for Cundwiramurs (and she for him) when he says,

Wenn irdische Minne den Wert der Treue in sich trägt..., hat sie etwas gemein mit der gotes minne, steht nicht in Gegensatz zu ihr, ist vielmehr ihr irdisches Abbild.... So ist die Treue, die Parzival in den langen Jahren Condwiramurs bewahrt, ein Band, das ihn auch in diesen Jahren der Gottentfremdung immer noch mit Gott verbindet.

When earthly love carries within itself the virtue of loyalty..., it has something in common with the love of God. It does not stand in opposition to it, rather it is its earthly reflexion.... So it is with the loyalty which Parzival shows to Cundwiramurs during several long years. It is a bond that in these years when

⁶ In keeping with tradition I have given the line number rather than the page number when quoting from Gottfried. The translations from Gottfried are my own.

he is distant from God still connects him with God” (as quoted in Blamires 249).

Clamide, the knight who tried to force Cundwiramurs to marry him, is a good example of what this love would be like if it were not tempered by this type of religious devotion. In Book IV when he sees that he cannot have Cundwiramurs, the most beautiful woman in Parzival’s work, he is completely undone. The power of this type of love when left unchecked by a higher force is demonic and destroys everything in its path (Blamires 255).

A similar type of problem affects Parzival in the famous scene where he sees three drops of blood in the snow. These remind him so powerfully of the beauty of his wife that he succumbs to a stupor and is incapable of any rational action. Only after he has chosen the Grail as his life’s goal, as opposed to his wife, is Parzival able to reunite with Cundwiramurs, who then becomes a “mediator between the transcendental powers of God as expressed through the symbol of the Grail and of the world as expressed through *minne*” (Blamires 250).

After her initial meeting with Parzival where she takes the initiative in saving her country, Cundwiramurs becomes completely dependent on Parzival. It wouldn’t be too strong a statement to say that she becomes his *anima*. Thus, we are led to consider the Jungian implications of this character and where she might fit on Neumann’s schema. The first conclusion is obvious. Her great beauty places her squarely in the positive upper half of the chart. Her concern for her people as the widowed queen of Pelrapeire suggests that she has qualities of the M+ axis in her makeup. But her primary function as just mentioned is as the inspiration that allows Parzival to overcome the discouragement he feels in his search for the Grail. This, of course, suggests the A+ axis as being her true home.

Besides Cundwiramurs, Herzeloide is the only figure discussed who has both M+ and A+ characteristics. But as the future queen of the Grail, Cundwiramurs claim to this honor seems to me more secure. If one looks at Neumann’s schema, one sees at the top on either side of the M+ and A+ axes the name of Mary, the mother of Christ. Parzival’s redemption of the Grail society is a Christomimetic act. It should come as no surprise then that his wife fulfills the equivalent female role.

Conclusion

Looking at the paths charted on Neumann’s schema by the six characters discussed in this paper, one notices the following. First, the

characters considered cannot be represented by a point on the schema. While Neumann's chart contains various mythological and religious figures as points, any careful consideration of a literary figure must show that figure's action. Good figures never remain static. Second, of the seven paths charted (there is one for Herzloyde and Parzival and one for Herzloyde and Gahmuret), only two are similar, those for Ampflise and Belecane. Both of these characters begin by moving upward on the A+ axis, but then retreat to the center of the schema and move down the M- axis because they wish to hold Gahmuret.

The other figures all describe different courses on the schema. While Sigune, Belecane, and Ampflise describe the M- axis, Sigune and Cundrie travel on the A- axis. Herzloyde moves along different axes in her relationships with her husband and her son, as one might expect, and Cundwiramurs moves directly between the M+ and A+ axes, thus confirming that she has the requisite qualities to become the Grail Queen.

It is also interesting that the six women considered represent all the axes of Neumann's schema. Is it possible that a truly successful work of literature of the scope of Wolfram's *Parzival* will always present female characters that, when taken together, represent the entire feminine archetype? One thinks, for example, of the *Divine Comedy*, *The Canterbury Tales*, or *Orlando Furioso*. Isn't one of the most satisfying aspects of these works the sense of completeness at the end? They seem to symbolize the entire cosmos, and how could that be possible without also modeling the complete feminine archetype?

If one were to do this type of analysis with other works from the courtly literature of the German High Middle Ages, eventually one would be able to compare different female characters by the path they trace on the schema, and by doing so one might check to see whether what has been written about them concurs with their trajectories on the schema. Obviously different authors will write differently about their heroines, but just as obviously this method might help to define various types of heroines and show the critic what to look for in their actions.

References

Berman, Morris. *The Reenchantment of the World*. Ithaca: Cornell University Press, 1981.

Blamires, David. *Characterization and Individuality in Wolfram's 'Parzival'*. London: Cambridge University Press, 1965.

Brontë, Emily. *Wuthering Heights*. Ed. Christopher Heywood. New York: Broadview Press, 2002.

Goethe, Johann Wolfgang von. *Goethes Faust: Der Tragödie erster und zweiter Teil Urfaust*. Ed. Erich Truntz. Hamburg: Christian Wegner Verlag, 1963.

Gottfried von Strassburg. *Tristan*. Ed. Karl Marold. Vol. 1. Berlin: Walter de Gruyter, 2004.

Lachmann, Karl (Ed.). *Wolfram von Eschenbach*. Karl Lachmann. 6th ed. Berlin: Walter de Gruyter, 1926.

Neumann, Erich. *The Great Mother: An Analysis of the Archetype*. Trans. Ralph Manheim. Princeton: Princeton University Press, 1974.

Singer, Irving. *The Nature of Love*. Vol. 2. Chicago: The University of Chicago Press, 1984.

Wagner, Richard. *The Ring of the Nibelungen Fourth Part: The Twilight of the Gods (Götterdämmerung)*. Trans. Frederick Jameson. New York: Kalmus, no date.

Wolf, Norbert R. "Die Minne als Strukturelement in Parzival Wolframs von Eschenbach." *Euphorion* 64 (1970): 59-74.

Wolfram von Eschenbach. *Parzival*. Trans. Helen M. Mustard and Charles E. Passage. New York: Vintage, 1961.

Parzival and the Hero Cycle

Jessica Pierce

Southern Utah University

Abstract

The purpose of this paper is to show that there is more to becoming a hero than the journey alone; a hero must develop psychologically and philosophically before he can claim the title of "hero". By using Plato's tripartite soul theory which states a person must learn to balance reason, the spirited element and bodily appetites, and E.R. Dodds's Shame and Guilt society theory in which the two societies are separated by the differing standards of each society, I show how a character must balance these aspects of himself to become a hero. For example, the Shame society is concerned with upholding a good reputation while the focus of the Guilt society is maintaining personal standards. I believe that combining the tripartite soul and Shame and Guilt society theories makes up the psychological and philosophical background of the hero. To these theories I will be adding my own hero cycle which maps out a hero's development through the course of a story. I will also introduce the grace line, which is the falling and redemption of a hero as he moves through the hero cycle.

While studying Wolfram's *Parzival*, a cycle, which will be termed the hero cycle, manifests itself in the development of the characters Parzival and Gawan.

The hero cycle correlates to the society with which the hero is associated (Figure 1). E.R. Dodds theorizes in his book, *The Greeks and Irrationals*, that there are two societies the Shame and Guilt societies. These societies differ in the emphasis on societal worth and individual worth. Societal worth defines the Shame society. People in this society guard their reputation because it is the summation of their character. For example, the character, Gawan, is accused of killing a man unfairly in a duel. And so he fears that his fellow knights will think he is a murderer. An invitation for a duel is offered to Gawan, he accepts it to clear his name. The modern equivalent of this can be seen with Marty McFly from the *Back to the Future* series. Whenever Marty is called a chicken or a coward he makes the same decision as Gawan to fight, because if he does not prove his bravery the accusation of cowardice is correct. Therefore Gawan, a knight from the courtly society, embodies the idea that King Arthur's court is a shame driven society (Dodds, 32) (Wolfram) (*Back to the Future*).

In the other society, the Guilt society, the importance of individual worth takes precedence over reputation. It is more important that the hero realizes *who* he is than *what others* think of him. This shift can be seen in the story of Oedipus Rex. Oedipus is secure in his position as king, but when he is accused of killing King Laius, he starts to question his situation. He starts to have questions like: "Who killed the king?" "Did I kill the king?" "Who am I?" The first question is one that a person from the Shame society would ask. If Oedipus only asked "Who killed the king?" then the title of murderer would be the definition of Oedipus Rex. The next question, "Did I kill the king?" shows a shift from merely a title of society to a more personal opinion of self. Instead of looking outward for the killer Oedipus starts to turn the search inward. The last question, "Who am I?" marks the internal focus of Oedipus Rex and by asking this question shows that he is now in the Guilt society (Dodds, 33-4)(Harrison).

Parzival starts to question his purpose in life much like Oedipus Rex. Parzival makes two mistakes. First, he kills his cousin Ither and second, he fails to ask a pivotal question while he stays at the Grail castle; one that would set the Grail inhabitants free from a curse. Because he lacks knowledge, Parzival does not understand how he has disgraced himself. He wanders for some time in search of answers to his questions and goes through the average sage phase as demonstrated below. Parzival shows in his attempt to identify himself that he is from the Guilt society. He does not care what other people think about him;

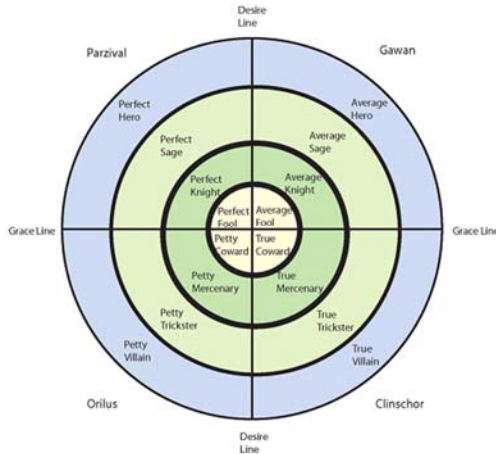

Figure Key

Desire Line- Marks the balance of the Hero's tripartite soul

Grace Line- Marks when the nature of the character is challenged and defined

<p>Perfect Fool- has a balanced tripartite soul with reason being the main element</p> <p>Average Fool- has an unevenly balanced tripartite soul, favoring reason and the spirited element</p> <p>Petty Coward- the tripartite soul is imbalanced, favoring bodily appetites and the spirited element</p> <p>True Coward- the tripartite soul is driven mainly by bodily appetites or the spirited element</p>	<p>Perfect Knight- has control over the tripartite soul and may start to cross the Grace line</p> <p>Average Knight- may struggle with his tripartite soul and is starting to cross the Grace line</p> <p>Petty Mercenary- either the spirited element or bodily appetite are starting to take control and is beginning to cross the Grace line</p> <p>True Mercenary- bodily appetite dominates the tripartite soul and is starting to cross the Grace line</p>	<p>Perfect Sage- the tripartite soul is balanced, and is in the Grace phase, which reveals his character to be selfless</p> <p>Average Sage- the hero is still struggling with the tripartite soul and is in the Grace phase</p> <p>Petty Trickster- bodily appetite or the spirited element is in charge and the Grace phase reveals the character to be self-serving</p> <p>True Trickster- bodily appetite drives the character and the Grace phase reveals his selfish desires</p>	<p>Perfect Hero- has mastered the tripartite soul, defined his character, and is secure in his society</p> <p>Average Hero- may struggle with the tripartite soul but he has defined his character and is comfortable with his society</p> <p>Petty Villain- either the spirited element or bodily appetite rules and is unhappy within a society</p> <p>True Villain- bodily appetite is the main focus and the character has a complete disregard for any society or its rules</p>
--	--	--	--

Figure 1. The Hero Cycle

instead, he is more concerned with defining his character, which is the key focus of the Guilt society.

In addition to appeasing the rules of the society the hero espouses, he also has to balance what Plato calls the tripartite soul. Plato theorizes that the soul is divided into three elements: reason (logic or wisdom); the spirited element (emotional drives like courage, anger, love); and

bodily appetite (desire or need). How the hero maintains the balance between these elements drives the character forward in the story. Using Marty McFly as an example again, his spirited element or pride leads his actions when he is called a coward. In *Parzival* the character Gawan deals with the tripartite soul through the course of his adventures (Lavine, 49-53) (*Back to the Future*).

Gawan travels to the magician, Clinschor's, castle. There Gawan finds a series of trials that no knight has been able to withstand before. First, there is a wildly bucking bed that Gawan finds will not allow him any rest. Next, a lion is released into the room. Gawan discovers that to kill the lion he must avoid the bed or else it will crush him. Once the lion is dead, arrows are fired into the room and Gawan must seek some sort of shelter or else he will die. All of these trials symbolically represent the tripartite soul. The bed is bodily appetite; the lion is the spirited element being courage and pride; and the arrows represent knowledge and quick wit. By conquering all of the elements Gawan is able to succeed where so many other knights have failed. It is important to note that in most stories the main character or protagonist will not have to face all elements of the tripartite soul at once. For example, *Parzival* succumbs to his bodily appetite when he kills his cousin Ither to obtain his red armor.

With this understanding of the Shame and Guilt societies and the tripartite soul, it is easier to understand the structure of the hero cycle. Two of the most important components of this cycle are the desire and the grace lines. The desire line functions as a marker to indicate the balance of the hero's tripartite soul and the grace line marks when the hero has made a definitive decision that shows the true nature of his character. Associated with the grace line is a period or phase of deliberation that leads up to the crossing of the grace line. These lines come into focus as a character goes through the hero cycle.

In most stories, the hero starts as a perfect fool. The balance of the tripartite soul is almost equal where bodily appetite has been replaced with more basic needs like food and shelter. *Parzival* is in the perfect fool phase while he lives with his mother. It is only when he encounters knights for the first time and is exposed to a new society that he is able to progress as a character.

After a few adventures, *Parzival* meets his cousin, Ither, outside of King Arthur's castle. The exchange that takes place shows *Parzival* crossing the desire line. Ither has red armor with which *Parzival* becomes entranced and will do anything to obtain. *Parzival* challenges Ither to a duel for the armor and kills him. Killing Ither for his armor illustrates *Parzival* crossing the desire line. He did not need the armor; rather, he wanted it. This also shows that his tripartite soul desires bod-

ily appetite rather than the spirited element and reason. Once Parzival has obtained the armor he becomes an average knight.

The balance of the tripartite soul in an average knight favors the spirited element and bodily appetite. Reason is not as prevalent as the other elements. Parzival finds the Grail Castle and while he stays there this imbalance is obvious. The Grail castle is under a curse because of the actions of Anfortas. He is the king of the Grail society and as a young man he fell in lust with a woman named Orgeluse and fought for her honor. This results in Anfortas receiving a wound to his groin by a poison tipped spear. The way to cure Anfortas is to ask him the question, "What ails you?" Parzival, even though he sees Anfortas in obvious pain, forgoes asking this question because he thinks at this time he was behaving as a knight should and as a result Parzival is cursed as well.

Shortly after Parzival leaves the Grail castle, he encounters King Arthur's camp. It is here that Cundrie, a member of the Grail society, brings Parzival and Gawain's misdeeds to light. The course of action taken by Parzival and Gawain reinforces the differences in their societies. Parzival, coming from the Guilt society, seeks guidance to rectify his wrong doings, while Gawain, being driven by the Shame society, accepts the duel to clear his name. It is at this time that Parzival meets Trevrizent, the hermit. This meeting marks the beginning of the average sage phase.

The average sage phase is when the hero has a personal dilemma and receives guidance from an outside source. This source uses his life and personal experiences as examples to aid the hero in overcoming and understanding his circumstances. For example, Trevrizent had been a knight of the Grail castle when his brother, Anfortas, received the fateful wound. Trevrizent left to pray for forgiveness on behalf of Anfortas. It is here that Parzival learns he could have been king of the Grail castle, but because he did not ask the question he brought disgrace upon himself. This error upsets Parzival to the point that he withdraws from society and wanders the countryside in order to answer the question, "Who am I?" An example of a modern sage today is Yoda from the Star Wars series. He helps Luke master his Jedi powers and gives him advice about the course of action he should take concerning his friends (Star Wars: Ep. VI).

When Parzival leaves to contemplate his situation and the advice given to him by Trevrizent, he enters the grace phase. The grace phase is a period where the hero processes the information given to him by the sage and compares it with the path that he has been following and tries to come to a decision. The duration of the grace phase depends on the hero. It could be several years, months, or moments. Parzival, for

example, takes about four years to come to a decision. Gawain, on the other hand, sleeps on his decision. Once a hero comes to a decision he is able to cross the grace line.

The grace line marks the moment when the hero makes a decision that reveals his true nature and defines his character. For Gawain, this comes when he learns that the man, with whom he must duel to clear the charges of murder, is in love with and is loved by Gawain's younger sister, Itonje. Knowing that a duel between the two men would ultimately result in death for one or both of the men and heartache for Itonje, Gawain decides to find a different way to defend his honor. Parzival, however, crosses the grace line during the time he wanders the countryside. He is only mentioned in passing when Gawain is the focus of the story, but these glimpses show an evolution of Parzival's character. This manifests itself when Gawain meets Orgeluse and he offers to be her knight. She scoffs at Gawain's offer and states that many knights have fought for her honor except for one. This knight turns out to be Parzival and since he refuses to fight for her he proves that he has control of his tripartite soul because she is the same woman that enticed Anfortas and ultimately brought the curse on the Grail castle.

It is important to note that there are minor grace lines that the hero crosses as well. These moments also define the character, but the consequences from the decision made at the time do not impact the hero until later, or are not as dire and immediate as the consequences that the hero receives when he is in a later phase. Parzival leaving the pivotal question unasked at the Grail castle is one instance of a minor grace line; another example can be seen with Peter Parker from the first Spiderman movie.

After Peter fails to get compensation for winning a fight in a wrestling match, he witnesses someone rob the fight promoter. As he is escaping, the robber runs towards Peter. The promoter shouts at Peter to stop the man, but Peter, angry that he did not get all of the money promised him, lets the man go by without any attempts to stop him. By not stopping the man, Peter shows that his tripartite soul is heavily unbalanced in favor of bodily appetite in that he wants revenge for not being fully compensated. Peter finally realizes he needs to find balance with his tripartite soul when he discovers his Uncle Ben dying after the robber just mentioned fatally wounds him. Both of the examples given show that at the time the character made the decision the consequences were not immediate, but the incident prompts the character to change an aspect of himself (Spiderman).

An example of a major grace line comes from the Star Wars: Return of the Jedi. When the Emperor is killing Luke, Darth Vader watches passively. It is in this moment that Darth Vader decides the life

of his son is more important to him than the rules of the Emperor. He kills the Emperor, which in the end, results in his own death as well. It took years for the moment to come, but Darth Vader was able to cross the grace line and somewhat redeem his character (*Star Wars: Ep. VI*).

Darth Vader is also an example of a hero refusing to cross the grace line because of selfish desires. Also, a character can refuse to cross the grace line to redemption and instead focus on selfish desires. The characters Orilus and Clinschor from *Parzival* exemplify this. Orilus's wife Jeschute appears as though she has had an affair when really she met a very young and foolish Parzival. Orilus refuses to listen to his wife's story and assumes she slept with another man. He lets his pride and wrath control his actions, and as a result he decides to punish his wife Jeschute by not allowing her to change into any new clothes and denying her and her horse inadequate food. In addition to the physical treatment, she is also not allowed to speak to Orilus. It is only when Parzival meets the couple and explains to Orilus the truth that Orilus is able to believe and forgive his wife.

Another *Star Wars* example can be seen with Qui-Gon Jinn from *Star Wars: The Phantom Menace*. Qui-Gon seeks the advice of Yoda about the course he should take with the training of Anakin. Yoda warns that Anakin is too old and too fearful to be a proper Jedi, but Qui-Gon ignores Yoda's warning and decides to train Anakin anyway. This decision results in innumerable tragedies as is evidenced in the later films. Both Qui-Gon Jinn and Orilus let their pride and avarice guide their actions and others must suffer for it (*Star Wars: Ep. I*).

Another character in *Parzival* that refuses to cross the grace line for selfish reasons is the magician Clinschor. Little detail is given about this character, but it is revealed that he used to be a knight and slept with a king's wife. As a result, the king had him castrated. Instead of learning from his mistake, Clinschor let his anger and lust for revenge drive him to terrorize several towns and to enslave and entrap women in the castle that Gawain encounters. This shows that his tripartite soul is heavily in favor of the bodily appetite and the spirited element. The modern equivalent of Clinschor would be the Joker from the *Batman* series. The Joker shares the same ruthlessness and complete disregard for the rules of society, and he lacks compassion for others much like Clinschor (Kane).

The characters Orilus, Qui-Gon, Clinschor, and the Joker illustrate how if a hero does not balance his tripartite soul he can become a petty villain or a true villain. The difference between a petty villain and a true villain is the balance of the tripartite soul. For a petty villain, the balance is heavily in favor of the bodily appetite and the spirited element while reason no longer has a strong influence on the character.

The balance of the tripartite soul for a true villain has bodily appetite being the lead element and the spirited element has turned to more negative emotions like pride or revenge and reason is now justification for the actions that the true villain undertake.

If a character can balance the tripartite soul properly and choose to cross the grace line with good intentions he can then progress to the level of a hero. Gawain and Parzival, once they cross the grace line, are both able to enjoy their rewards after their trials and adventures. Gawain is married and Parzival is able to ask the question at the Grail castle that frees everyone trapped inside. He is then made king of the castle. Parzival now exhibits the qualities found in a perfect hero. He maintains control over his tripartite soul, and he is secure in himself and answers the question, “Who am I?” Gawain, however, is an average hero because he still struggles with the tripartite soul which is shown by the affair he has with Antikonie.

Through the examples given from Parzival, one can articulate the hero cycle as the characters progress through the story. First by understanding the society the hero espouses clarifies the actions that are acceptable and appropriate for a character to take, whether it is upholding honor in the Shame society or seeking personal knowledge in the Guilt society. Next, comprehending and striking a balance with the tripartite soul drives the character forward with his progress on the hero cycle. This progression is marked by the desire line and how the hero balances the elements of the tripartite soul governs if the character is a hero or a villain. Also, the grace line and grace phase focus the character and his relation to a true hero.

As the story of Parzival has shown, a character can evolve from a fool yearning for knowledge of another world to a knight exploring and challenging all that he encounters until he has a question that he cannot answer on his own and seeks guidance. If the character keeps his tripartite soul in balance and makes a decision for positive progress based on the assistance given to him by the sage then he will be able to cross the grace line and become a hero. Whether it is a hero from the Shame society that has defended his name or a hero from the Guilt society that has to search inward to discover who he is before facing his foe a perfect hero can be found in anyone as long as a balance has been established with the tripartite soul and the decision made to cross the grace line and accept fate as it comes.

Works Cited

Back to the Future. Dir. Robert Zemeckis. Perf. Michael J. Fox, Crispin

Glover, Christopher Lloyd, and Lea Thompson. Universal Pictures. 1985. Film.

Dodds, E. R. *The Greeks and the irrational*. Berkeley: U of California Press, 1951. 28-63. Print.

Harrison, James. "Oedipus Rex". Tanner Center. Cedar City, Utah. 28 Jan. 2010. Lecture.

Kane, Bob, and Bill Finger. Creators. *Batman*. Art by Bob Kane, and Jerry Robinson. DC Comics. 1940. Print.

Lavine, T.Z. *From Socrates to Sartre: the Philosophic Quest*. New York: Bantam Books, 1984. 43-53. Print.

Spiderman. Dir. Sam Raimi. Perf. Willem Dafoe, Kirsten Dunst, James Franco, and Toby Maquire. Columbia Pictures. 2002

Star Wars: Episode I—The Phantom Menace. Dir. George Lucas. Perf. Jake Lloyd, Natalie Portman, Ewan McGregor, and Liam Neeson. Lucasfilm. 1999. Film.

Star Wars: Episode VI—Return of the Jedi. Dir. Richard Marquand. Perf. Carrie Fisher, Harrison Ford, Mark Hamill, and Billy Dee Williams. Lucasfilm, 1983. Film

Wolfram von Eschenbach. *Parzival*. Trans. A.T. Hatto. New York: Penguin Books, 2004. Print.

Victory of the Ash Buttocks: The Role of Hybridity in Colonization, Decolonization, and Postcolonization

Jennifer Gibb

Dixie State College

Abstract

*The creation of the colonial hybrid as a political tool played an integral part in the conquest of indigenous lands by colonial rulers as well as the ability to maintain control of these locations. Eventually hybridity turned on its creators and armed native peoples with the ideologies and knowledge to overthrow colonial powers. This gave rise to a post-colonial period in which the internalization of hybridity left lingering effects, both sociological and psychological, for the once colonized people. This timeline of hybridity can be traced through *Things Fall Apart* by Chinua Achebe, *Death and the King's Horseman* by Wole Soyinka, and *The House of the Spirits* by Isabel Allende. These works of literature provide the opportunity to experience hybridity in states, forms, and intensities different from our own and affords the ability to understand colonialism in the emotionally charged circumstances in which they occurred.*

An understanding of colonial hybridity is vital to the comprehension of modern race issues in their historical context, but it is within a purely historical context that a deeper understanding is abstracted into facts and dates. It is therefore important to study hybridity within other frameworks. Works of literature can provide insight into colonialism, postcolonialism, and hybridity in the emotionally charged contexts in which they occurred. It is through works of literature that the role of hybridity in colonization, decolonization, and the aftermath of post-colonization become clear: Hybridity is central to the fissures caused by colonization and decolonization as well as the healing to be done postcolonization.

Colonial hybridity is the notion that indigenous people are through various means civilized, educated, and assimilated into the colonizers' culture while at the same time relegated to a state of perpetual otherness that allows their continued subjugation. The creation of this colonial hybrid played an integral part in the conquest of indigenous lands by European rule as well as the ability to maintain control of said locations from a distant center of power. *Things Fall Apart*, *Death and the King's Horseman*, and *The House of the Spirits* create a timeline of colonization through which hybridity can be viewed.

Imagine a great war fought between two white colonizers and thousands of native Igbo tribesmen hungry to preserve their culture, freedom, and way of life. This, of course, could never occur, but in *Things Fall Apart*, Chinua Achebe shows how a very small number of white colonists are able to infiltrate and take over Igbo society. Achebe uses Part One to explore the richness of this native culture, while Parts Two and Three examine the various methods and designs used by Colonizers to take control of a stable, strong community. The creation and exploitation of the hybrid "other" enables the colonists to gain control but also has far reaching effects into the culture, its people, and the future social psychology of their posterity.

When six missionaries arrive in Mbanta, only one of them is white. The interpreter is Igbo but from a different location, and Achebe uses their arrival to show the folly of being subject to a white man by poking fun at his translations. The interpreter says 'my buttocks' instead of 'myself.' When speaking to these two outsiders, the villagers continue to call the interpreter "your buttocks" (85). This allusion to those who make themselves subservient being 'a buttocks' resonates throughout the second half of the novel. Similarly, the guards who work for the District Commissioner are called Kotma and Ashy-Buttocks for the ash-colored shorts they wear. These Kotma are indispensable to the white administrators in controlling the indigenous people. They enforce the laws and will of the newly established white

government, act as jailers to those who have offended this government, and even facilitate the arrest of the tribal leaders of Umuofia (a pivotal point in the novel that signals the complete loss of indigenous rule).

The Kotma are a poignant example of Ania Loomba's description of hybridity in that they "mimic but never exactly reproduce English values, and that their recognition of the perpetual gap between themselves and the 'real thing' will ensure their subjection" (146). This state of existence undoubtedly caused a psychological split for the Kotma, but it also caused a social rift between them and their native counterparts. The "Kotma of the Ash Buttocks" were scorned and ridiculed by the clan, and the clan in turn was left feeling betrayed and broken. At a great meeting of the clan, Okika expresses this sentiment, "We who are here this morning have remained true to our fathers, but our brothers have deserted us and joined a stranger to soil their fatherland" (115). This desertion has far greater effects than a simple act of disloyalty. Because Umuofia could not have been colonized without the exploitation of the hybrid other, in the end Umuofia defeated itself.

The most clear-cut example of hybridity in *Things Fall Apart* is Mr. Kiaga. He is a native missionary left behind in Mbanta after Mr. Brown returns to Umuofia. There he not only preaches the gospel and acquires new followers, but he also behaves like a white man ignoring many social norms and customs. Mr. Kiaga saves twins from death in the Evil Forest and welcomes outcasts into the congregation. He seems to do this out of genuine love and concern and with the best of intentions. This character might well have been based on Achebe's father, who was in fact a missionary. Achebe's own viewpoint can therefore reflect the voice of the colonial hybrid: "...in our village you had two sides—the 'people of the Church', as we were called, and the 'people of the world', the others. And there was a certain amount of distance; although we were in the same village there was a certain distance" (quoted in Serumaga 129). Achebe's comment shows how hybridity locked many indigenous people into a state of perpetual otherness. They were neither white nor native.

It is unclear in the novel why Mr. Kiaga chose to align himself with the beliefs and social framework of the colonizers, but Achebe offers other examples of why natives may have chosen to take on the mantle of the hybrid. One such example is Nneka, who had four pregnancies that resulted in the birth of twins, an occurrence that is looked down upon in the Igbo culture. Because when twins are born, they are placed in the Evil Forest to die, it is no surprise that, "She was very heavy with child...they found she had fled to join the Christians"(87). Another example is Okonkwo's own son, Nwoye, who voluntarily leaves his way of life to align himself with the faith of the colonizers.

He does so because he does not understand many of the cultural practices of his people and because he wishes to leave the abusive and oppressive hand of his father. Many of the other natives who are drawn to the Christians are disillusioned with Igbo society or are excluded from it altogether, such as the outcasts or *osu*. “An *osu* could not attend an assembly of the free-born, and they, in turn could not shelter under his roof. He could not take any of the four titles of the clan, and when he died he was buried by his kind in the Evil Forest. How could such a man be a follower of Christ?”(90). Mr. Kiaga welcome the *osu* into the folds of the Church, and hybridity spreads under the veil of religion.

Although there are several examples and explanations given in the novel as to why many of the natives allow themselves to be molded into the hybrid other, it may well be that the introduction of the colonizers was made possible through the pre-established social psychology of the Igbo tribe. Victor C. Uchendu points out that

“The Igbo world is one in which change is expected. Change is accepted as a realistic adjustment to the status and role structure, as an adjustment to the world around them...Believing that he chose his roles, the Igbo is constrained to make a success of his social position or career” (233).

Furthermore,

“The individual freedom of choice fostered by Igbo culture allows innovation. There is opportunity for experimentation as well as tolerance for failure and admiration for success. The most important factor for the acceptance or rejection of an innovation is its status implication for the individuals and groups concerned” (234).

The attitude towards change and the desire to make oneself a success produced the perfect situation for the colonizers to create and exploit the hybrid other.

Things Fall Apart shows how hybridity enables colonizers to gain control. *Death and the Kin's Horsemen* takes the reader further down the colonial timeline to show how hybridity allows the colonizers to remain in power. It illustrates the difficulties that continue when one distinct culture attempts to impose its norms and beliefs on another. The hybrid characters display how they are both necessary to colonial power as well as integral to preservation of indigenous culture.

Sergeant Amusa is a native who serves under Simon Pilkings, the District Officer, to maintain control of his own indigenous people. He is not treated with respect by Pilkings, and when he attempts to do his bidding in the market, he is again met with disrespect by the native people. He is told to leave, and when he refuses, he is mocked and ridiculed. His only recourse is to return to Pilkings and exaggerate the situation so that Pilkings might retaliate. Although Amusa may seem to hold a position of power as a law enforcement officer, he is actually quite powerless because of the hybrid nature of his situation in which he exists between two different social groups but not a part of either one. This position has left him without standing in any social group other than perhaps that of his fellow hybrids.

Another interesting hybrid character in *Death and the King's Horseman* is Joseph, Pilkings's house boy. Although he appears relatively few times throughout the play, he is an excellent example of how the colonizer felt about the hybrid other that they had themselves created. Joseph serves Pilkings like a slave. Although Joseph has been converted to Christianity, Pilkings openly mocks him for his belief in what the colonizers have taught him. "Don't tell me all that holy water nonsense also wiped out your tribal memory" (24). Pilkings's treatment of Joseph emphasizes the colonizers' intention and need to ensure that the hybrid remain subjected to perpetual otherness.

Joseph's subservience is a stark contrast to Olunde, the Elesin's son. With Pilkings's help, Olunde was sent to England to study medicine. He returns upon hearing the news of the king's death because he understands the fate of his father. His conversations with Jane and Pilkings show that his education has given him the understanding to defy the hypocrisy of the colonizers. (The English are at war to protect their freedoms while they oppress others in distant lands.) Olunde's experiences within the motherland of the colonizers as well as his education give him the power to stand up to Pilkings and his wife. His final act of completing the suicide that his father was unable to complete is actually done to maintain social cohesion of his native people but also serves to show Pilkings that he cannot completely overtake and/or assimilate the Yoruban culture. Elesin poignantly states: "You may have stopped me in my duty but I know now that I did give birth to a son. Once I mistrusted him for seeking the companionship of those my spirit knew as enemies of our race. Now I understand. One should seek to obtain the secrets of his enemies. He will avenge my shame, white one. His spirit will destroy you and yours" (52).

The scene, which most poignantly displays the dual facets of the hybrid other, takes place when the girls in the market ridicule Amusa. This scene is actually a symbolic display of hybridity clashing against

itself. Amusa is an example of how hybridity acts as a tool in the hands of the colonizers, while the girls show how the goal within hybridity to educate indigenous people turns on the colonizers. In his essay, Olakunle George points out that the girls represent the educated, “Westernised” native and the white man’s future adversary (215). They are able to defend their community because they understand the colonizers’ language and cultural patterns—because they are the hybrid other. The fact that the girls can be perceived as victorious over Amusa has clear meaning. The girls have these departing words for Amusa: “Then tell him to leave this market. This is the home of our mothers. We don’t want the eater of white left-overs at the feast their hands have prepared” (31). Although these words are somewhat harsh, they re-enforce the underlying meaning behind the conflict. The more like the colonizers the natives become, the more they are able to defy the loss of their culture. Therefore, in a sense, in losing their native self they are able to reclaim it.

The House of the Spirits provides a picture of hybridity’s progression down the colonial timeline into postcolonialism. Set in Chile, the story plays out during an era in which hybridity no longer occurs intermittently but has taken over most of the culture. The few remaining groups who have not been Europeanized are referred to as “Indians.” They are often “othered” and cast in an unflattering light. For example, when Esteban Trueba arrives at Tres Marias as the Patron, one of the poor, unwashed Indian children defecates at his feet. This symbolic action makes him appear more like an animal. This idea that the Indians are a lower race of people works to the advantage of the upper class who subjugate them. Hybridity and colonization have locked them into the socioeconomic status of what Ana Maria Manzanos and Jesus Benito refer to as an “internal colony.” This occurs when “the colonized Other was seen to share the geographical space of the colonizer... (and when) these ethnic Others continue to be kept apart and contained, ‘linguistically and spatially,’ as if in a final attempt to avoid their inevitable hybridization, both social and cultural” (50-51).

Allende makes it clear within the novel that the Indians are kept apart from society to avoid their hybridization, thereby continuing their oppression: “The peasants were still living exactly as they had in colonial times” (68). This is accomplished through various means of violence: physical, political, and economic. Esteban exhibits all of these forms of violence towards the people of Tres Marias at some point in the novel. He beats Pedro Tercero in front of his father when his actions go against Esteban’s wishes. He ensures their continued poverty by paying them with pink slips of paper they must use to purchase goods through him. This allows him to work them day in and day out

with no hope of independence from their reliance on him as their patron. Trueba and the other patrons force them to vote the way they see fit and threaten them with physical violence and the loss of employment if they go against the patrons' political agendas.

In contrast to the Indians, Esteban Trueba behaves like the colonizers once did. He bathes and dresses for dinner. He wears fine clothes and seeks to gain wealth even at the expense of others. He ruthlessly rules over the natives who work on his land with the belief that they are incapable of doing things properly or taking care of themselves in an acceptable way. As patron he acts as the colonizers would, believing that all things indigenous are to be disdained. He clearly expresses his feelings about Tres Marias and its inhabitants when he states, "The place would go to hell! There would be no one to give orders, sell the crops, take responsibility for things... They need someone to do their thinking for them, someone around to make decisions, someone to help them" (283). Trueba takes great pride in the fact that he is educating the people of Tres Marias and encouraging their immersion into a more European cultural system. During the second half of the novel, the lower classes begin to revolt against the oppressing upper class. It is no surprise that this comes after they have been hybridized. It is as if colonization began a cycle of oppression, followed by hybridization, and then an uprising against subjugation.

Things Fall Apart illustrates the devastating affects of colonial hybridity in the early stages of colonization. It ends with the tragic death of Okonkwo, who cannot live to face the fate colonialism has left him. The story may end with Okonkwo's death, but the far-reaching social implications of colonization affected the native people into post-colonization and into the authors' own lifetimes. This is why *Things Fall Apart*, *Death and the King's Horsemen*, and *The House of the Spirits* are able to depict colonization as a dynamic force that became ingrained in the society and psychology of those who lived it, especially through colonial hybridity, which changed the way the colonized viewed not only themselves but also the culture that made them who they are. In an interview given in 1964, Achebe explained that colonization had left his people with "a 'crisis in the soul.' We have been subjected—we have subjected ourselves too—to this period during which we have accepted everything alien as good and practically everything local or native as inferior... and the whole society during this period began to look down on itself" (quoted in Nwoga 125). These sentiments reverberate throughout the timeline of hybridity created by these three novels.

The creation of colonial hybridity has therefore caused social rifts as colonialists invaded and destroyed indigenous cultures and also cre-

ated internal psychological strife. This damage can never be erased, but there is a possibility to move forward with a deeper understanding of hybridity. Hybridity is not monodirectional. Even as the colonized are forced to assimilate parts of their oppressor's culture, various aspects of the indigenous cultures are absorbed into the colonizers' literature and culture. Homi Bhabha asks that we open ourselves to the idea of international culture "not based on exoticism or multi-culturalism of the diversity of cultures, but on the inscription and articulation of culture's hybridity...and emerge as the others of ourselves" (quoted in Laragy 3). In a world of globalization and unprecedented access to information among various cultures and peoples, we are all in some way living in a state of hybridity. Literature provides the opportunity to experience hybridity in states, forms, and intensities different from our own and affords the ability to understand colonialism beyond its historical context. Traveling the literary timeline of *Things Fall Apart*, *Death and the King's Horseman*, and *The House of the Spirits* is a journey that offers a unique understanding of the creation and history of hybridity with the goal of a more complete understanding of the present.

Works Cited

- Achebe, Chinua. *Things Fall Apart: Authoritative Text, Contexts, and Criticism*. Ed. Francis Abiola Irele. New York: Norton, 2009. 3-117.
- Allende, Isabel. *The House of the Spirits*. New York: Bantam, 1985.
- George, Olakunle. "Tragedy, Mimicry, and 'The African World.'" *Death and the King's Horseman: Authoritative Text, Backgrounds and Contexts, Criticism*. Ed. Simon Gikandi. New York: Norton, 2003. 207-22.
- Laragy, Elizabeth. "Hybridity." Queen's University Belfast. Web. 5 Oct. 2009.
- Loomba, Ania. *Colonialism/Post colonialism*. 2nd ed. New York: Routledge, 2005.
- Manzanas, Ana Maria, and Jesus Benito. *Intercultural Mediations: Hybridity and Mimesis in American Literatures*. New Brunswick: Transaction, 2003.

Nwoga, Donatus. "Interview with Chinua Achebe." *Things Fall Apart: Authoritative Text, Contexts, and Criticism*. Ed. Francis Aviola Irele. New York: Norton, 2009. 124-26.

Serumaga, Robert. "Interview with Chinua Achebe." *Things Fall Apart: Authoritative Text, Contexts, and Criticism*. Ed. Francis Aviola Irele. New York: Norton, 2009. 129-35.

Soyinka, Wole. *Death and the King's Horseman: Authoritative Text, Backgrounds and Contexts, Criticism*. Ed. Simon Gikandi. New York: Norton, 2003. 1-63.

Uchendu, Victor C. "The Igbo World." *Things Fall Apart: Authoritative Text, Contexts, and Criticism*. Ed. Francis Aviola Irele. New York: Norton, 2009. 225-35.

A Mean and Ungentlemanly Act: Casaubon's Passive Aggressive Maneuvering in George Eliot's *Middlemarch*

Randy Jasmine

Dixie State College

Abstract

*In the infamous catechism of rational self-interest from Balzac's *Pere Goriot*, the Machiavellian criminal Vautrin boasts, "I'm like a great poet, but I don't write my poems: my poems are what I do, what I feel" (p. 86). No one would ever mistake the blustery Vautrin for George Eliot's withered and inept scholar Edward Casaubon, but this statement can be productively examined in relation to both characters. Whereas Vautrin clearly comes across as a pragmatic character, Casaubon hides his personal desires within mummified layers of bitterness, scorn, and silence. Casaubon's greatest achievement, the work for which he will be known to posterity, is not his unwieldy and ultimately unfinished "Key to All Mythologies"; instead, it is the codicil he adds to his will that disinherits his wife Dorothea if she marries his*

cousin Will Ladislaw. This legal tactic is shrewd, merciless, and effective—adjectives that cannot be applied to the rest of his life's work. In this paper, I argue that Casaubon attempts to make up for all of his other failings by revealing his jealousy and codifying his resolve in the legal document he leaves behind. As Eliot builds her great realist project, Casaubon's egoism (a trait held by all of the characters in the novel) is presented as being particularly selfish and malicious. I also suggest that, from a practical standpoint, the passive aggressive nature of Casaubon's actions make them far more effective than any open protestations would have been. Just as Vautrin hides behind his aliases and disguises, Casaubon is able to secrete his intentions toward his wife and his cousin behind the blanket of his pathetic failures. Mr. Casaubon's legal amendment of his will is his great poem.

Almost invariably, Edward Casaubon from George Eliot's *Middlemarch* is viewed as a weak and ineffectual character, blindly plodding through both his hopelessly ambitious scholarly work and his ill-conceived marriage to the young and vibrant Dorothea Brooke. No doubt with significant reason, readers and scholars alike are moved to comment on the failings of this particularly irksome man. On a current blog dealing with literary and pop culture topics, Anthony Campbell has actually coined the term “the Casaubon delusion.”

This pejorative designation is based on Casaubon's attempt to “show that all mythologies of the world are corrupt fragments of an ancient corpus of knowledge” (Campbell). Campbell elaborates on this delusion, describing it as the “tendency of the mind to search for all-inclusive answers.” Campbell goes on to point out that “we are all liable to fall into it [the so-named delusion] in one way or another, probably because it is an exaggeration of an inbuilt function of our minds.” Presumably, Casaubon overindulges in this impulse, ultimately offering his name to the condition. According to Campbell, the failure of Casaubon is so monumental that it can be used to explain and name an entire range of human pathology. These observations are interesting, and they are in line with the way many readers ultimately view Casaubon. I suggest, however, that Casaubon's psychological disorder is not delusional at all. In my opinion, Casaubon suffers from a type of recognized and defined oppositional disorder, specifically passive aggressive personality disorder.

Most of the casual and student readers with whom I have discussed the novel are inclined to experience negative reactions toward

this character. Most wince at the thought of Dorothea marrying such a prune of a man. They readily join Casaubon's young cousin Will Ladislaw in his rejection of Casaubon's metaphysical scholarship as pie-in-the-sky dreaming. They are also amused by Dorothea's sister, Celia, and her frank descriptions of Casaubon as "very ugly" (Eliot, p. 15), with "two white moles with hairs on them" (p. 16). Celia is also bothered by "how he scrapes his spoon" while he is eating soup and by the fact that "he always blinks before he speaks" (p. 43).

Contemporary literary criticism has not been much kinder to Casaubon. The fictional scholar and his work are often identified as embodying a quixotic element within the pages of Eliot's novel. According to Malcolm Bull, "the writing of [Casaubon] focuses on the past and is characterized by a chaotic and fragmentary style" (quoted in Faubert, p. 47). Michelle Faubert believes that "Dorothea views her impending marriage to Casaubon as the certain fulfillment of her desire to be subsumed in 'a divine consciousness,' a superhuman intellect, which she mistakenly ascribes to the merely pedantic Casaubon" (p. 50). From very early in the marriage, Dorothea begins to adjust her attitude toward her husband, suspecting that she has married a man with "a blank absence of interest or sympathy" (Eliot, p. 188). Such assessments seem perfectly accurate on the surface, but these scathing condemnations of Casaubon ignore his position of relative power in the world he has chosen for himself.

Interestingly, one critic who takes a slightly different tack is Dwight H. Purdy, who in his examination of Eliot's repeated use of the word "poor" suggests that this epithet is used as often to describe Casaubon, as it is to describe his wife: "For every 'Poor Dorothea,' a 'Poor Casaubon.' The narrator, absolutely consistent with Casaubon, invests a great deal in the adjective's power to arouse sympathy. Whenever it appears, it comes with a thick array of other rhetorical pleas for compassionate understanding" (Purdy, p. 810). Purdy calls for a benevolent, yet still patronizing, reading of this man.

Is all of this negative criticism fair? Do we have, when we examine Edward Casaubon more closely, merely a pathetic scholar and impotent husband? Is he deserving of only our scorn or our sympathy? Like all of the developed characters that Eliot presents in *Middlemarch*, the admittedly flawed figure of Casaubon is more complex than he first appears to be. Throughout the body of her work, and particularly in *Middlemarch*, Eliot invites examination of her characters as actual human beings, complete with strengths and weaknesses and psychological complications. In my look at Casaubon, I will attempt to, as Kate Flint puts it, "engage with imaginary characters" (Flint, p. 65) as if they existed in the real world. Casaubon impresses readers as a human being

(a view famously shared by E. M. Forster in *Aspects of the Novel*), and most of these readers picture him always among his research notebooks, papers, and rough drafts. This disorganized and unpublished body of work is the primary evidence used to condemn him as a failure: a failure on such a large scale as to offer Campbell the name for his patented theory of delusion.

Like his psychological make-up, however, the truly lasting accomplishments of Casaubon's life may be underestimated and misunderstood. His major problems stem from his lack of progress on his academic work and from his miscalculation in his personal life. He does not question his choice of Dorothea as his wife, but he questions the very necessity for marriage. I do not agree with several popular conclusions about him, his work, and his marriage. He does not see his own life as a complete failure; his jealousy of Ladislav and Dorothea does not stem, I would argue, from a fear of cuckolding; although he does want his *Key* to be published, I do not believe he sees this work as a significant scholarly contribution that must see the light of day because of its transcendent truth.

Casaubon actually lives a life of luxury. He is able to pursue his academic work because of his great wealth and his nominal ecclesiastical position. In fact, he is able to carry out his aggressive dislike for Ladislav, a feeling that predates his marriage to Dorothea, in a variety of passive aggressive ways. After Dorothea first meets Ladislav and asks about his career prospects, Casaubon snipes, "I fear that my young relative Will Ladislav is chiefly determined in his aversion to these callings by a dislike to steady application" (Eliot, p. 75). Casaubon keeps his relative at arm's length, and he never misses an opportunity to spread a negative opinion of Ladislav behind his back.

Casaubon is also able to exert a great deal of influence on Dorothea, much of it even after he has shuffled off the mortal coil. Although he keeps both the strength of his resentment toward Ladislav and his suspicion of his wife's lack of fidelity to his scholarly work secret while he is living, the amendment that he makes to his will discouraging the marriage between Dorothea and Ladislav (Dorothea would be disinherited of the wealth and property from her husband if this happens), actually serves as a very formidable legacy. Casaubon clearly has looked up from his books long enough to form these opinions about Ladislav and Dorothea and to act on them in his typical passive aggressive manner.

It is truly an extraordinary event when Casaubon shows up at Tip-ton Grange and commences his courtship of the youthful Dorothea Brooke. He has spent his life engaged in scholarship, interacting only rarely with fellow scholars and high Church of England officials, but

for some reason he sees the possible benefits in having a female companion later in his life. He quickly realizes, however, that he has made a miscalculation by proposing marriage to Dorothea:

Mr. Casaubon . . . spent a great deal of his time at the Grange in these weeks, and the hindrance which his courtship occasioned to the progress of his great work—the Key to all Mythologies—naturally made him look forward the more eagerly to the happy termination of courtship. But he had deliberately incurred the hindrance, having made up his mind that it was now time for him to adorn his life with the graces of female companionship, to irradiate the gloom which fatigue was apt to hang over the intervals of studious labor . . . Hence he determined to abandon himself to the stream of feeling, and perhaps was surprised to find what an exceedingly shallow rill it was. (Eliot, p. 57)

Even before the actual marriage, Casaubon knows, not only that his physical needs will not be met, but that he has overestimated the power of those needs. He certainly cannot go back on his decision, so he is anxious to get married merely to get back to work.

Later in the novel, when Casaubon learns of the seriousness of his health problems, and when he begins to come to terms with the reality of his rapidly approaching death, his actions do not follow the pattern of someone who is delusional. He is jealous of a possible future relationship between Dorothea and Ladislav, but his fear is based on the damage to his reputation as a scholar that will result from such liaisons. Casaubon is sure that Ladislav is maligning his work in front of Dorothea, and this fear, far from being delusional, is absolutely correct. On only their second meeting, Ladislav says to Dorothea of Casaubon's work, "it is a pity that it should be thrown away . . . for want of knowing what is being done by the rest of the world. If Mr. Casaubon read German he would save himself a great deal of trouble" (p. 197).

Ladislav's continued criticism erodes Dorothea's faith in her husband's project, and this is the infidelity that Casaubon has always feared: "Poor Mr. Casaubon! This suffering was the harder to bear because it seemed like a betrayal: the young creature who had worshipped him with perfect trust quickly turned into the critical wife" (p. 418). Casaubon sees Ladislav not as a sexual threat, but as an intellectual threat, someone who will expose his scholarly ineptitude to his once-devoted disciple. It is to limit the damage of this attack that Casaubon adds the codicil to his will, an action that even those closest to the couple misread as a fit of passion and sexual jealousy—a mean and ungen-

tlemanly act that inaccurately casts doubt upon his wife's moral character—an unintended, but perhaps not a wholly undesirable consequence for Casaubon once deceased.

Casaubon's final legal act as Dorothea's husband is a noteworthy success if viewed from a certain perspective. He clearly detects Dorothea's reservations about his work and her hesitancy to have it published posthumously. The narrator tells us, of Dorothea, that "the poor child had become altogether unbelieving as to the trustworthiness of that Key which had made the ambition and the labor of her husband's life" (p. 455). With her doubt so clear and his death imminent, Casaubon has very few options, and he resolves on a course of action that seems to defy all earlier assessment of his character. He acts swiftly, decisively, and profoundly to try to affect a lasting influence over not so much his relationship with his wife, but his reputation. He shows Dorothea and everyone close to her the power and influence someone in his position can command. It is important to note that this action follows the pattern set by Casaubon earlier in the novel. His most important and strongest feelings are always expressed through letters. This is how he proposes to Dorothea, and this is also how he continually expresses his displeasure with Ladislaw, eventually forbidding him to visit Lowick. Like most people who exhibit some form of passive aggressive tendencies, passion, criticism and even reprimand of others is often expressed in absentia.

Of Casaubon's legal action, Sir James Chetham angrily reflects, "I say that he has most unfairly compromised Dorothea. I say that there never was a meaner, more ungentlemanly action than this—a codicil of this sort to a will" (p. 461). Mr. Brooke adds by way of possible justification, "Poor Casaubon was a little buried in books—he didn't know the world" (p. 461). These last words particularly, spoken by the character in *Middlemarch* who clearly is the most delusional, ring with irony and further legitimate the idea of Casaubon's success through absence and inscrutability.

Unlike Mr. Brooke, Casaubon actually knows the world very well and seems to understand perfectly his place in it. After all, he has lived the life of a wealthy and unencumbered clergyman and landowner. His position and his money have allowed him to remain aloof from his intellectual inferiors and from his sniping critics. Although his academic work is hopelessly out of step with current trends in scholarship and will never be completed or published, "Poor Casaubon" seems an inappropriate and misleading description. He is not an isolated, threadbare scholar who dies among the stacks of his personal library without anyone noticing. He is a petty and conniving man who has the power to get what he wants, at least for a while.

As I have been arguing throughout, Casaubon is not delusional, but instead he exhibits model passive aggressive behavior. The *Handbook of Personality Disorders* describes the category of “passive aggressive personality disorder (PAG),” which is an “oppositional disorder—a *DSM-IV* [*Diagnostic and Statistical Manual of Mental Disorders*, fourth edition] category closely related to [PAG]” (Magnavita, p. 156). People who fit into these categories are often angry and depressed, and in the example given in the *Handbook*, the subject manifesting these disorders “burned out from trying to meet impossible expectations . . . [and] adopted the strategy of resisting coercion at all costs” (Magnavita, p. 156). This description sounds eerily familiar to Casaubon as he is working on his *Key to All Mythologies*, while constantly frustrating all of Dorothea’s attempts to assist him. Furthermore, PAG/oppositional disorder sufferers often attempt to “win by losing,” and even more relevantly to Casaubon, they enjoy sending, sometimes elaborate, messages to those they feel have wronged them, and these messages are often connected to “after-death fantasies” (Magnavita, p. 156). Once again, the behavior associated with this type of disorder accurately describes Casaubon’s actions.

Casaubon relays his displeasure toward Ladislav always by way of letters, and he ultimately manifests his disappointment with Dorothea through the amendment to his will. He envisions these maneuvers as capable of controlling and frustrating his principle antagonists, even in his permanent absence. Casaubon can confidently be diagnosed as suffering from PAG, but this analysis in no way suggests that he is delusional. The characteristics attributed to his PAG make him come across as unpleasant and off-putting to those around him, and to readers as well; however, this type of behavior also seems to be a viable defense mechanism for someone living in a world as complex as the intricate provincial society of Middlemarch. I would go even farther and say that perhaps passive aggressive behavior might be the basis for living a highly successful life, particularly in a less moral world than the one over which Eliot has artistic control.

Although Eliot was a realist, she was also a moralist; Harold Bloom suggests that she possesses “a nearly unique spiritual authority” (p. 1) among her novel-writing contemporaries. All that I am suggesting here is that under such circumstances, Casaubon’s spiteful doings are sure to be trumped by Dorothea’s near-saintly devotion to helping others. In another, less spiritual world, Casaubon would probably be even more successful than he turns out to be with his machinations.

In the infamous catechism of rational self-interest from Balzac’s *Pere Goriot*, the outspoken criminal Vautrin boasts, “I’m like a great poet, but I don’t write my poems: my poems are what I do, what I feel”

(p. 86). No one would ever mistake the muscular, blustery, and mono-maniacal Vautrin for Casaubon, but this statement can be productively examined in relationship to both characters. Whereas Vautrin clearly comes across as a pragmatic character who does whatever he wants, Casaubon hides his personal desires within mummified layers of bitterness, scorn, and silence. Vautrin is clearly immoral and dangerous, but he is also inviting and intriguing to many readers because of his unapologetic Nietzschean honesty and his larger-than-life presence. He does, however, end up imprisoned at the end of the novel, at least partly because he has chosen open rebellion against society as his primary means of self-satisfaction. Casaubon, on the other hand, while no superman, coolly and calculatedly lives a life with material comfort entirely devoted to his chosen purpose. At the end of that life, he is still able to affect many of those around him through his passive aggressive actions. His *Key* is never published, but his petulant letters, his aloof behavior, and his spiteful codicil constitute the cannon of his life's work.

Casaubon's influence is negated only by the remarkable, and somewhat unbelievable, responses to his codicil from both Dorothea and Ladislaw. Dorothea decides that the wealth she inherits from her husband can be put to better use by others, whether she ultimately decides to marry Ladislaw or not. Ladislaw himself, although not saintly by nature, is made nearly so by his love for Dorothea, and he too eliminates his cousin's hold over him primarily through acts of altruism. Place Casaubon in the Paris of Balzac, however, and I think you have a character who wields an enormous amount of power; you also have a character who is read as being dangerous rather than delusional. His passive aggressive behavior and his oppositional tendencies would serve him well in a world ruled by narcissism and materialism.

In the end, I don't find myself defending or even admiring Casaubon. Instead, I simply suggest that he is often misread as a failed and laughable character. I am puzzled as to why other characters in this novel are rightly identified as complex, while Casaubon frequently is not. Such critical assessments only deal with the surface of the man, and I think do a disservice to the significant literary project that George Eliot creates in *Middlemarch*. Her characters do consistently come across as human beings, none more so than Edward Casaubon.

Works Cited

Balzac, Honore. *Pere Goriot*. Trans. Burton Raffel. New York: Norton, 1997.

Bloom, Harold. Introduction. *Modern Critical Interpretations: Middlemarch*. Ed. Bloom. New York: Chelsea House, 1987. 1-7.

Campbell, Anthony. "The Casaubon Delusion." *Anthony Campbell's Home Page*. <http://www.acampbell.ukfsn.org/essays/skeptical/casaubon.html>. Accessed 31 Mar 2010.

Eliot, George. *Middlemarch*. New York: Barnes and Nobel Classics, 2003.

Faubert, Michelle. "A Possible Source for George Eliot's Edward Casaubon." *ANQ: A Quarterly Journal of Short Articles, Notes, and Reviews* 18.2 (2005): 46-52.

Flint, Kate. "The Materiality of *Middlemarch*." *Middlemarch in the Twenty-First Century*. Ed. Karen Chase. Oxford University Press, 2006. 65-86.

Magnavita, Jeffery J, ed. *Handbook of Personality Disorders: Theory and Practice*. Hoboken: Wiley, 2004.

Purdy, Dwight H. "'The One Poor Word' in *Middlemarch*." *Studies in English Literature, 1500-1900* 44.4 (2004): 805-21.

Measurement of the Imaginary Index of Refraction of UO_x in the Extreme Ultraviolet

Heidi M. Dumais, R. Steven Turley, and David D. Allred

Brigham Young University

Abstract

We measured the transmittance and reflectance of two reactively sputtered diodes prepared with approximately 20 nm of UO_x in the extreme ultraviolet (XUV) at the Advanced Light Source at Lawrence Berkeley National Laboratory. Fitting the reflectance data to the Parratt model yielded the thickness of the UO_x film. This thickness combined with a simple analysis of the transmission measurements provides estimates for the imaginary part of the index of refraction for UO_x at approximately every tenth of a nanometer from about 3 nm to 30 nm with emphasis in the 12- to 13-nm range. The analysis discussed in this paper yields only the imaginary part of the complex index but will lead to a more robust analysis to find both the real and imaginary parts of the index of refraction. These values provide researchers with information for modeling, design, and fabrication of optical systems in the extreme ultraviolet.

I. Introduction

The motivation for studying materials in the extreme ultraviolet (XUV) includes integrated circuit applications,¹ astrophysical observations,² planetary physics,^{2,3} and high-resolution microscopy.^{4,5} Photolithography techniques for microelectronics involve projecting an image over photo-sensitive materials to etch patterns for integrated circuits. The use of shorter-wavelength light in this process increases the resolution, leading to smaller features and faster circuits.^{1,6} In astrophysics, energetic processes that emit in the XUV can be studied in greater detail as better optics are developed in that range.² In planetary science, helium ions trapped in the Earth's magnetic field radiate in the XUV.³ As a result, images and movies of the Earth's magnetic field have been made using XUV optics from the IMAGE satellite.⁷ In optical microscopy, shorter wavelengths improve resolution of smaller samples with less preparation than that of electron microscopy. Understanding the optical properties of materials in the XUV allows for the design and fabrication of optical systems that can be used for all of these applications, in addition to a better understanding of the materials themselves.^{4,5}

Lunt⁸ predicted that uranium would be a useful element in XUV optical systems. Elemental uranium has been studied for application in thin-film XUV optical systems,^{9,10,11} however, the formation of oxides on the surfaces of uranium films makes using the pure element difficult. Uranium oxides themselves can be used for similar applications with greater stability. Uranium dioxide has been studied in the visible and infrared¹² but not the XUV. The constants in the XUV are often predicted (but not measured) using the independent atom approximation (IAA).¹³ The IAA weights the optical constants of each element by its density in the compound. This approximation is most valid at high energies (x-rays) and away from band edges. Its use in the XUV for compounds is being investigated here and elsewhere.^{14,15,16} Programs at the Center for X-Ray Optics (CXRO) website¹⁷ typically use the IAA to calculate optical constants for the compounds, using elemental data such as that from Henke et al.¹³ Recent in situ measurements of the optical properties of elemental uranium in the XUV¹⁸ conflict with those recorded in the CXRO database. The following analysis simply compares the measured values with the CRXO values.

Light incident on a material can be transmitted, reflected, or absorbed. An equation for the intensity of light reveals which parts of the index of refraction affect reflection and absorption:

$$I = I_0 \cdot e^{-\frac{4\pi}{\lambda}(1-\delta+\beta i)t} \quad (1)$$

where I and I_0 are the measured and incident intensity, λ is the vacuum wavelength, t is the distance the light travels, $1-\delta$ is the real part of the index of refraction, and β is the imaginary part. From Equation (1), the imaginary part of the index of refraction gives rise to an attenuation factor that corresponds to absorption. The real part of the index of refraction would affect the intensity of the reflected fields.

Both the real and the imaginary parts of the index of refraction depend on the wavelength of light incident on the material. Most materials, including air, strongly absorb XUV light, which ranges from 1 to 60 nm. This range of wavelengths is also highly sensitive to surface roughness and contamination. Additionally, the real part of the index of refraction for materials in this region of the spectrum lies near unity for many materials, resulting in low reflection. This is because the Fresnel coefficients depend on the difference in the refractive index between various layers. Consequently, mirrors for this region must be constructed of layers of thin films with precise thicknesses meant to cause constructive interference between reflected fields from each interface. Figure 1 shows a simplified schematic for light incident on a four layer stack of thin films (on the nanometer scale) with reflectance at each interface. For clarity, Figure 1 does not show the multiple reflections that would occur at each interface. To properly model the reflectance and transmission of a stack of thin films, the recursive Parratt method,¹⁹ which considers the fields traveling up or down in each layer, must be used.

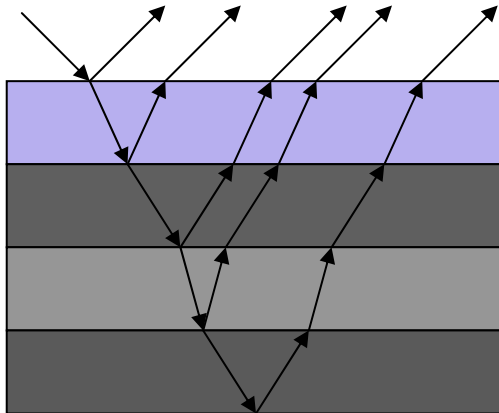

Figure 1: Reflection at thin film interfaces.

II. Background and Calibration

We measured two multilayer samples at Lawrence Berkeley National Laboratory's Advanced Light Source (ALS). Both samples were prepared by sputtering uranium onto a silicon diode with a 7.69-nm SiO₂ layer. Half of each diode was covered by a shutter to leave it uncoated for comparison; however, the first sample was reactively sputtered (with oxygen), while the other was oxidized after sputtering.

To calibrate the measurements made at ALS, the response of the uncoated part of the diode was compared with the standard measured by the ALS beamline 6.3.2 personnel. Using Matlab, the normalized signal was given a wavelength offset to minimize the squared difference between the calibration curve and our measurement. The resulting wavelength shift, 0.0038 nm, was subtracted from each wavelength measurement made. This value amounted to a negligible difference, as the precision of our wavelength measurements was 0.01 nm.

After calibration, the reflectance and transmission of the sample at various wavelengths was measured to provide data for the calculation of the index of refraction of the sample material. Measurements of the transmitted intensity are made at a set wavelength by varying the angle of incidence of the beam. Each successive run has a different wavelength, so that analysis of each run yields the index of refraction at that wavelength. The reflectance runs vary the incident angle from near grazing to near normal for a given wavelength.

III. Analysis

As a result of measuring the reflected intensity from near normal to near grazing, the curves varied by several orders of magnitude. These curves show peaks and valleys in the reflectance measurement due to interference between fields that were reflected at the various thin film interfaces on the diodes. Figure 1.1 illustrates the principle behind how light incident on the top surface can be reflected at several interfaces and yield a more intense reflected beam than would be possible with a single material layer. The angles at which the maxima and minima occur depend on the thickness of the layers. It is therefore possible to use the reflectance runs to calculate the thickness of each thin film layer.

The samples were prepared to be at least 20 nm thick; however, to find a more precise thickness, the reflectance data were fit to the Parratt recursive method¹⁹ including a Nevot-Croce correction factor for the surface roughness by varying the real and imaginary parts of the index of refraction and the film thickness in Matlab. This method uses the

indices to calculate Fresnel coefficients for each interface. The thickness of the SiO_2 layer was held constant at the measured value of 7.69 nm based on ellipsometry performed on the uncoated diodes at the BYU campus. The large changes in reflectance during a single run require a weight function to prevent the optimization program from over- or under-emphasizing any one portion of the data.¹⁴ Figure 2 shows a typical reflectance run fit to the Parratt model including the weight function, the data, and the fit curve. The average thickness of the UO_x layer for these runs was 21.8 ± 0.7 nm for the sample allowed to oxidize after sputtering, and 27.4 ± 0.4 nm for the sample that was sputtered with oxygen. Several reflectance runs were performed on the same diode position for each sample at different wavelengths to obtain these average thicknesses and standard deviations. These thicknesses allowed for a first approximation of the imaginary part of the index of refraction based on analysis of the transmission data.

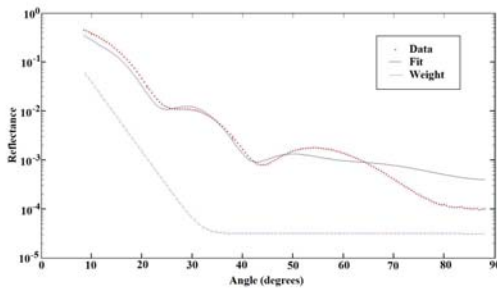

Figure 2: Typical reflectance data fit to the Parratt model using a weight function.

Measurement of the transmission as a function of angle at a given wavelength provided the data for the determination of the imaginary part of the index of refraction. The wavelengths measured ranged from 1 to 40 nm in varied step sizes. As a first approximation, the transmission intensity was assumed to be of the form of Equation (1), with the following simplifications:

$$I = I_0 \xi e^{-\alpha t} \quad (2)$$

where I is the transmitted intensity, I_0 is the incident intensity, t is the distance the light travels through the sample, ξ is a factor that includes attenuation due to reflection, surface contamination, and surface rough-

ness. Figure 3 shows a cross-section of the sample with these parameters.

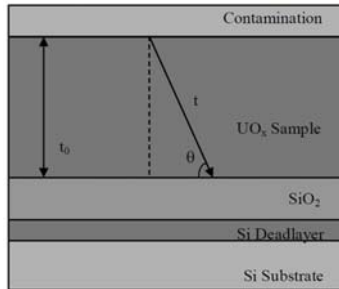

Figure 3: Geometry of transmission approximation.

The distance t is given by

$$t = \frac{t_0}{\sin \theta} \quad (3)$$

where θ is the angle measured from grazing which assumes perfect sample alignment and t_0 is the UO_x film thickness. To correct for possible misalignment of the sample, we add another fitting parameter to θ and substitute the expression for t into Equation (2) to get

$$I = I_0 \xi e^{-\frac{\alpha t_0}{\sin(\theta+\phi)}} \quad (4)$$

where ϕ corrects for the misalignment of the sample. Fitting the measured values to this model by varying the product of αt_0 , ϕ , and the product of $I_0 \xi$, we arrive at a value of αt_0 for each transmission run. The value of ϕ was within 0.3 degrees of zero for each run. This indicates that the alignment was very good and that Equation (4) represents the behavior of the data relatively well.

The reflectance analysis provided a value for t_0 , the film thickness, allowing for the isolation of α . By comparing the attenuation factor introduced in Equation (2) with that acquired from an expression for the intensity of the field, Equation (1), we can arrive at an equation for β in terms of α ,

$$\beta = \frac{\alpha \lambda}{4\pi} \quad (5)$$

Using Matlab, we calculated a value for β at each wavelength according to the preceding analysis. Figure 4 shows the results for the sample sputtered in the presence of O_2 and the sample that was allowed to oxidize after sputtering. The differences in the imaginary index for these samples indicate the importance of deposition techniques on structure in determining the optical properties of thin films.

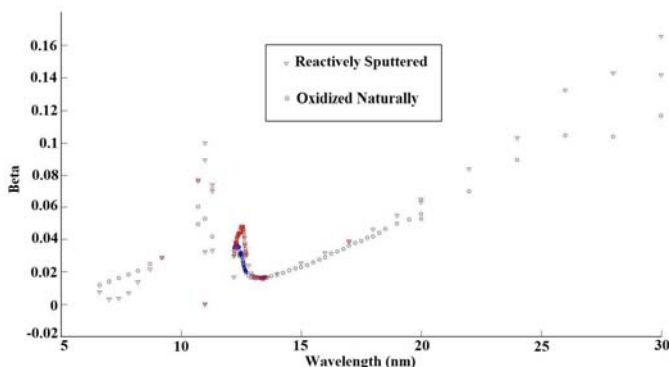

Figure 4: Measured imaginary index of refraction for sputtered UO_x samples.

IV. Results and Discussion

Figure 5 compares the values of the imaginary part of the index of refraction predicted by the CXRO database for U, UO_2 , and U_3O_8 with both samples as a function of wavelength. The reactively sputtered sample seems to follow the U curve in the longer-wavelength region before dropping to the U_3O_8 values in the shorter-wavelength range. The sample oxidized after sputtering qualitatively matches the CXRO values for U_3O_8 . Comparison with silicon and silicon dioxide values indicated that the presence of these elements did not influence the measurements made during this research. These data indicate that the sample that oxidized naturally formed a higher oxide, probably U_3O_8 . The reactively sputtered sample appears to have formed a lower oxide; however, the peak in the index was shifted toward longer wavelengths for the lower-oxide sample. The IAA cannot explain this type of behavior in a compound's refractive index. This indicates that further study of the lower oxide sample should be undertaken.

The analysis of the transmission data to arrive at the imaginary component of the index of refraction did not include the measured re-

flectance in the model. A more robust and in-depth analysis is required to confirm these results and calculate the real component of the refractive index. The BYU XUV research group is continuing to analyze these data in a more robust calculation to include both transmission and reflection to find both the real and imaginary parts of the index of refraction. Preliminary results indicate that the approximation discussed in this paper represents the data well and therefore provides a valid and accurate method for finding the imaginary part of the index of refraction.

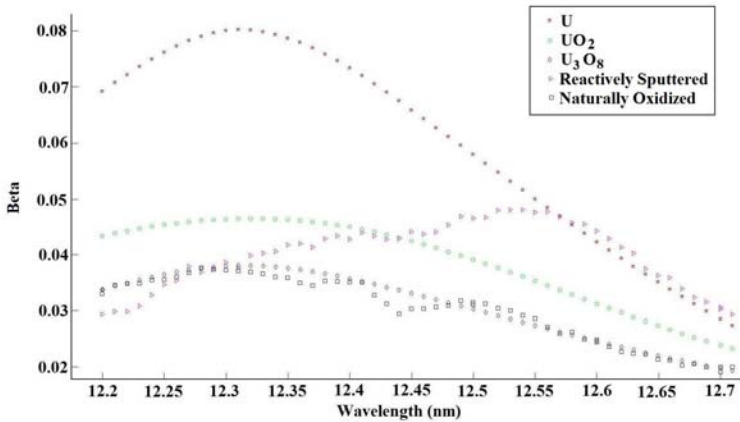

Figure 5: Comparison of CXRO predicted beta (imaginary portion of index) with measured values for both diodes.

V. Conclusion

The imaginary index of refraction for UO_x has been measured for two different sample preparation procedures. The data indicate that the index of elemental uranium does influence the compound's index, but the IAA cannot fully predict the behavior of β as a function of wavelength. Future research will refine these results, enable us to draw conclusions about the structure of the samples, and provide both the real and the imaginary parts of the index of refraction for UO_x in the XUV range. These values will aid researchers in the modeling of XUV optical systems for application to photolithography, astronomical imaging, planetary science, high-resolution microscopy, and materials characterization.

VI. Acknowledgments

The transmission and reflection measurements needed to calculate β were made at beamline 6.3.2 of the Advanced Light Source at the Lawrence Berkeley Laboratory by the authors, Keith Jackson, Zephne Larsen, and Alison Wells with the aid of Eric Gullikson, with beamtime granted under user contract # ALS-03197. The Advanced Light Source is supported by the Director, Office of Science, Office of Basic Energy Sciences, of the U.S. Department of Energy under Contract No. DE-AC02-05CH11231.

This research was funded by the Rocky Mountain NASA Space Grant Consortium and Brigham Young University.

References

U. Stamm, "Extreme ultraviolet light sources for use in semiconductor lithography—state of the art and future development," *J. Phys. D: Appl. Phys.* 37, 3244–3253 (2004). See, for example, <http://www.ssl.berkeley.edu/euve/sci/EUVE.html> and bibliography cited therein.

B.R. Sandel, A.L. Broadfoot, J. Chen, C.C. Curtis, R.A. King, T.C. Stone, R.H. Hill, J. Chen, O.H.W. Sigmund, R. Raffanti, D.D. Allred, R.S. Turley, and D.L. Gallagher, "The extreme ultraviolet imager investigation for the IMAGE mission," *Space Science Reviews* 91, 197-242 (2000).

W. Chao, B.D. Harteneck, J.A. Liddle, E.H. Anderson, and D.T. Attwood, "Soft X-ray microscopy at a spatial resolution better than 15 nm," *Nature* 435, 1210-1213 (2005).

K.A. Goldberg, I. Mochi, P. Naulleau, T. Liang, P.Y. Yan, and S. Huh, "EUV pattern defect detection sensitivity based on aerial image linewidth measurements," *J. Vac. Sci. Technol.* B27, 2916 (2009). See also references therein.

D. Attwood, "Soft X-rays and extreme ultraviolet radiation: principles and applications," Cambridge University Press, Chapter 10 (1999). See also <http://ast.coe.berkeley.edu/sxreuv/2005/Ch10.pdf> and <http://>

courses.ee.psu.edu/ruzylo/ee518/EUV%20Presentation.ppt

IMAGE Mission EUV images available online at <http://evu.lpl.arizona.edu/evu/>

S. Lunt, “The use of genetic algorithms in multilayer mirror optimization,” Thesis, Brigham Young University (1999).

I.A. Artioukov, R.M. Fechtchenko, and A.L. Udovskii, *Nucl. Instrum. Methods Phys. Res. Sect. A* 372, 517 (2004).

D.D. Allred, M.B. Squires, R.S. Turley, W. Cash, and A. Shipley, “Highly reflective uranium mirrors for astrophysical applications,” *Proc. SPIE* 4782, 212–223 (2002).

R.L. Sandberg, D.D. Allred, and S. Lunt, *Proc. SPIE* 5193, 191–203 (2003).

Q. Chen et al. “Structural characterization and optical properties of UO_2 thin films by magnetron sputtering,” *Applied Surface Science* 256, 3047–3050 (2010).

B.L. Henke, E.M. Gullikson, and J. C. Davis, “X-ray interactions: photoabsorption, scattering, transmission, and reflection at $E=50\text{--}30000$ eV, $Z=1\text{--}92$,” *Atomic Data and Nuclear Data Tables* 54 no.2, 181–342 (July 1993).

G.A. Acosta, “Scandium oxide thin films and their optical properties in the extreme ultraviolet,” Ph.D. dissertation, Brigham Young University (2007). Available online at http://www.physics.byu.edu/faculty/Allred/CV/Theses/acosta_dissertation_6.pdf

J.B. Muhlestein, “Optical constants for Y_2O_3 in the extreme ultraviolet,” Thesis, Brigham Young University (2009). Available online at <http://volta.byu.edu/pubs/JosephThesis.pdf>

N. Brimhall, N. Herrick, D.D. Allred, R.S. Turley, M. Ware, and J. Peatross, “Measured optical constants of copper from 10 nm to 35 nm,” *Optics Express*, Vol. 17 Issue 26, pp. 23873–23879 (2009).

CXRO resources available online at http://henke.lbl.gov/optical_constants/

N. Brimhall, N. Herrick, D.D. Allred, R.S. Turley, M. Ware, and J. Peatross, "Characterization of optical constants for uranium from 10 nm to 47 nm," *Applied Optics* Vol. 49, Iss. 9, pp. 1581–1585 (2010).

L.G. Parratt, "Surface studies of solids by total reflection of X-Rays," *Phys. Rev.* 95 (1954) 359.

Persistence of Magnetic Domain Memory Through Field Cycling in Exchange Bias Thin Films

Joseph Nelson, Brian Wilcken and Karine Chesnel
Brigham Young University

Abstract

The occurrence of memory effects in the formation of magnetic domains is both of fundamental and technological interest. We have probed the amount of domain memory in ferromagnetic thin films by using soft x-ray speckle cross-correlation metrology. We have found that a very strong domain memory (over 90%) can be induced in the ferromagnetic layer when subjected to exchange couplings with an antiferromagnetic layer. We show here the variation of the degree of memory as function of magnetic field through magnetization loop and the persistence of this memory through repeated field cycling.

1. Introduction

Let's imagine a magnetic hard disk that could be subjected to magnetic fields of any strength and not lose its data. Among many other uses, hard disks made from such a material would be extremely

useful for long-term data archives, which presently must be re-recorded every few years to protect against data degradation by external magnetic fields. The microscopic magnetic domains in such a material would need to have some kind of intrinsic memory or ability to reproduce a former morphology after application of a strong magnetic field. It is therefore technologically important to understand and control the fundamental properties that lead to the persistence of magnetic memory in some materials [1].

We are particularly interested here in the occurrence of memory effects in the formation of magnetic domains and their morphology throughout the magnetization cycle. A few years ago, it was found that memory effects can be triggered by the presence of structural defects in thin films [2]. When the film is smooth, the pattern formed by the magnetic domains is completely random each time the domains form. However, partial magnetic domain memory can be observed when the roughness of the sample is increased. In that case, the domains nucleate (begin forming) mostly at the same locations, that is, in the vicinity of structural defects. More recently, we have found that magnetic domain memory can be more fully controlled and optimized to almost 100% by inducing exchange couplings [3]. This effect has been evidenced in exchange bias (EB) films made of ferromagnetic/antiferromagnetic (FM/AFM) multilayers of finely adjusted thicknesses [4]. In such systems, the magnetic domain memory is found to be extremely high and robust over a large extent of the magnetization process [5]. We present here results obtained on a $[\text{Co}(4\text{\AA})/\text{Pd}(7\text{\AA})] \text{IrMn}(24\text{\AA})$ stacking, where the Co/Pd multilayer is AF and the IrMn alloy is AFM. The thicknesses have been optimized so that the Neel temperature and associated blocking temperature of this system is about 300K. Our measurements have been performed at low temperature, below the blocking point, in a zero-field (ZFC) state so the net magnetization of the system is zero.

2. Methods

To quantify the degree of domain memory in the FM films, we have used soft x-ray resonant magnetic scattering (XRMS) metrology. The XRMS technique was developed relatively recently [6], using the interaction between polarized light and magnetization in matter [7]. Essentially, the x-rays are tuned to the magnetic resonant energy of the material so that the scattering pattern generated is unique to the magnetic morphology of the sample.

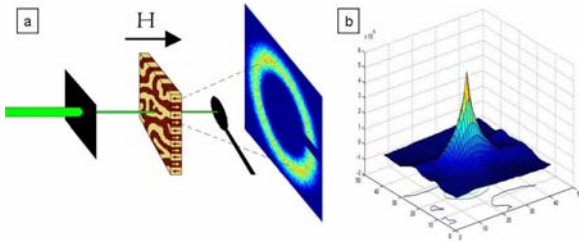

Fig. 1. (a) Sketch of the coherent x-ray resonant magnetic scattering experiment. The sample (not to scale) is here mounted in transmission geometry. Under the illumination of coherent x-rays, it produces a speckle pattern collected on a charge-coupled device (CCD) camera. (b) Cross-correlation pattern resulting from cross-correlating two scattering patterns similar to the one shown in (a).

In our experimental setup, shown in Figure 1(a), the x-rays irradiate the sample in transmission such that the magnetization in the material is parallel to the beam. The magnetic domains scatter the x-rays laterally, which are detected by charge-coupled device (CCD) [8]. The pattern formed by the coherent x-rays is called a speckle pattern and is unique to the exact microscopic configuration of the magnetic domains, as its amplitude is related to the true Fourier Transform of the magnetic profile.

Because the speckle pattern is unique to the exact pattern formed by the domains, the similarity between two speckle patterns is indicative of the similarity between the respective domain patterns. We use this fact to measure the memory in the system by quantifying the similarity between speckle patterns and, ultimately, the “degree of memory” ρ . To estimate ρ we use the technique of speckle cross-correlation [9]. The technical aspects of this approach and all the optimization steps are presented in detail elsewhere [10]. Briefly, if A and B are two distinct images, cross-correlating A and B is symbolized by the notation $A \otimes B$, and results in a correlation pattern as shown in Figure 1(b). The intensity of the peak in the center of such pattern indicates the similarity between the two images. We then integrate the peak in this cross-correlation result and normalize the integration by the cross-correlation of A with itself ($A \otimes A$) and B with itself ($B \otimes B$) as follows:

$$\rho = \frac{\sum A \otimes B}{\sqrt{\sum A \otimes A \cdot \sum B \otimes B}}$$

We refer to ρ as the degree of correlation, which translates here as the degree of memory. If A and B are exactly the same image, ρ will be equal to 1, the highest possible correlation value. If the two images are extremely different, ρ will be near zero. Thus, ρ provides an intuitive measurement of the domain memory of the sample.

3. Magnetic memory through magnetization loop

To obtain our scattering patterns, we demagnetized our EB film at high temperature, then performed a zero-field cooling (ZFC) down to low temperature to enhance exchange couplings in the material. We then recorded speckle patterns at different values of applied magnetic field, H , along the magnetization loop, shown in Figure 2(a). This magnetization loop, plotting the net magnetization of the film, M , as a function of the magnetic field H , was measured by vibrating sample magnetometry (VSM) at Brigham Young University, in the ZFC state at 20K. The fact that the descending branch does not match the ascending branch reveals a hysteresis effect, characteristic of FM materials. The amount of hysteresis at $M=0$, called the coercive field, is here about 30 mT. The saturation field on the ascending branch is about 350 mT and the nucleation field is about 50 mT, when descending from positive saturation. At saturation, all the magnetic moments are pointing in the same direction, so the magnetic profile of the FM film is flat and no magnetic feature can be observed in the scattering signal. A magnetic scattering signal (or magnetic speckle pattern) only occurs at nucleation when domains nucleate and start to propagate. While the field increases along a given branch of the magnetization loop, the magnetic scattering signal is intensified and peaks at the coercive point, then decreases and fades away at the opposite saturation. We have recorded magnetic speckle patterns at several points along each branches of the hysteresis loop. We repeated this measurement for several cycles, in order to cross-correlate speckle images taken at the same point on the hysteresis loop but separated by one or more cycles through the loop. The result of cross-correlating two images taken at the same field and separated by one or more cycles is called return-point memory (RPM). One interesting question is to understand the behavior of the RPM along the magnetization branch and if the behavior remains symmetrical.

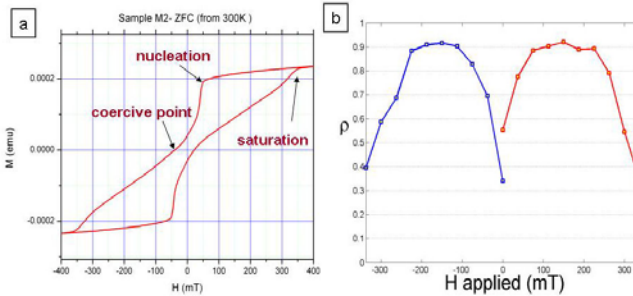

Figure 2. (a) Magnetization loop of our [CoPt]IrMn film measured by VSM, after ZFC cooling at 20K, with indication of nucleation, coercive and saturation points, respectively $H_n \sim 50$ mT, $H_c \sim -30$ mT and $H_s \sim 350$ mT. (b) Resulting degree of magnetic memory ρ for RPM, evaluated on the ascending branch (right curve) and descending branch (left curve) of the magnetization loop.

Results from our analysis are shown in Figure 2(b). Here, we cross-correlated scattering patterns separated by one field cycle. The result on the ascending and the descending branches are plotted together in Figure 2(b). First, we observe an extremely high domain memory, above 90%, meaning that the magnetic domains are returning to about 90% of the same morphology before and after the application of a full field cycle. This high degree of memory is obtained when the magnetization (on the vertical axis in Figure 2(a)) is near the coercive region. Second, we observe that the degree of memory varies with the magnitude of the applied field. Along the ascending branch, for example, going down from positive saturation toward negative saturation, it starts at a low level, about 0.35, at nucleation (when the first domains form), then peaks to 0.9 in the coercive region, and finally decreases again down to below 0.4 when the sample goes toward negative saturation. This low–high–low behavior is noteworthy because it is consistent with an exchange-coupling-induced magnetic memory as outlined in our recent paper [3]. It is interesting to note that this behavior differs from the memory observed in the rough films was highest at nucleation and relatively low in this coercive region [2]. Third, we observe that the behavior of RPM along the ascending and descending branches is fairly symmetrical, which is consistent with the symmetry of the magnetization loop itself. Some minor differences observed on the extremities of the branches, for example at $H = 0$, can be explained by an artificial bias resulting from instrumental limitations—the intensity of the scattering signal being very low, close to saturation, the signal-to-noise ratio is fairly poor at these extremities.

4. Magnetic memory through field cycling

Next, we wanted to know how robust this memory was after more than one field cycle. We collected scattering patterns at three specific field values ($H = 0, 75,$ and 150 mT), and repeated the measurement after one cycle, two cycles, and up to five field cycles separation. We then cross-correlated the patterns based on the number of field cycles separating them. We quantified the amount of RPM but also the amount of conjugate-point memory (CPM), where images on the descending branch are correlated with their conjugate images on the ascending branch. For example, if an image were taken at 75 mT, it would be correlated with an image taken at -75 mT after a half-loop cycle.

Figure 3 shows our results, measured for the three points $H = 0$ (nucleation), $H = 75$ mT (coercive point), and $H = 150$ mT (above coercive point). We observe a very high RPM, above 95%, at the coercive point, as indicated in Figure 3(a). We also observe that both RPM and CPM are pretty high in the coercive plateau region ($H \sim 75$ mT up to 250 mT). Both RPM and CPM are found to be above 90% in that region and also decreased very little after repeated field cycling. The lower value observed at $H = 0$ for CPM is potentially due to a combination of an experimental bias effect in the film caused by presence of an extra in-plane component in the applied field and an artificial bias caused by low signal-to-noise ratio at nucleation. More importantly, we find that for each given field value, the degree of correlation stays fairly stable, decreasing very little after repeated field cycling [11]. This stability reveals that the magnetic domain memory is very robust throughout field cycling.

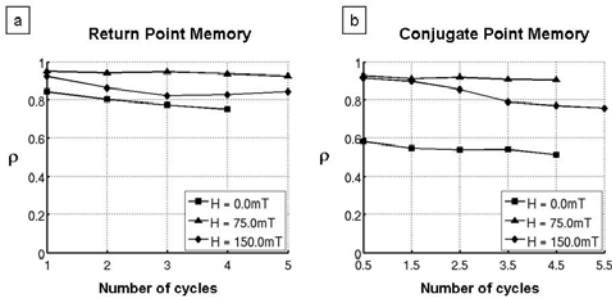

Figure 3. (a) Degree of RPM trough field cycling at $H = 0, 75,$ and 150 mT.; (b) Degree of CPM trough field cycling at $H = 0, 75,$ and 150 mT (a number $N=1.5$ means a separation of one cycle and a half, etc.)

5. Conclusion

In conclusion, we observe extremely high magnetic domain memory in our exchange-bias thin films. Not only are the domains over 90% reproducible after cycling through the hysteresis loop, but they continue to be just as reproducible after repeated field cycling. Such systems would be extremely useful for long-term data storage, as well as applications in which saturation by magnetic field is likely. In these applications, the information stored could not be erased by magnetic fields when below the blocking temperature.

Acknowledgments

We thank Matt Carey and Eric Fullerton for preparation of exchange bias films and Steve Kevan for valuable discussions about the cross-correlation methods and results. We acknowledge the Advanced Light Source, at Berkeley, California, who made the experiment possible. We recognize Brigham Young University's Office of Research and Creative Activities (ORCA) for the monetary support for the VSM instrumentation and for the research time.

References

- [1] H. Richter, "Density limits imposed by the microstructure of magnetic recording media," *J. Magn. Magn. Mater.* **321**, 467–476 (2009)
- [2] M. S. Pierce *et al.*, "Disorder-induced magnetic memory: Experiments and theories" *Phys. Rev. B* **75**, 144406 (2007).
- [3] K. Chesnel, E. E. Fullerton, M. J. Carey, J. B. Kortright, and S. D. Kevan, "Magnetic memory in ferromagnetic thin films via exchange coupling," *Phys. Rev. B* **78**, 132409 (2008).
- [4] S. Maat, K. Takano, S. Parkin, and E. Fullerton, "Perpendicular exchange bias of Co/Pt multilayers," *Phys. Rev. Lett.* **87**, 087202 (2001).
- [5] K. Chesnel, J.A. Nelson, S.D. Kevan, M.J. Carey, and E.E. Fullerton. "Oscillating spatial dependence of domain memory in ferromagnetic films mapped via x-ray speckle correlation." *Phys. Rev. B* **83**, 054436 (2011)

- [6] F. de Bergevin and M. Brunel, «Diffraction of X-rays by magnetic materials» *Acta. Cryst. A.* **37** (1981)
- [7] M. Blume, “Magnetic scattering of X-rays” *J. Appl. Phys.* **57**, 3615 (1985)
- [8] K. Chesnel, J. J. Turner, M. Pfeifer, and S. D. Kevan, “Probing complex materials with coherent soft X-rays,” *Appl. Phys. A-Mater. Sci. Process.* **92**, 431–437 (2008).
- [9] M.S. Pierce, et al. “Disorder-induced microscopic magnetic memory”, *Phys. Rev. Lett.* **94**, 017202 (2005)
- [10] B. Wilcken, “Magnetic Memory in Exchange Bias Thin Films” senior thesis, Brigham Young University, Department of Physics & Astronomy (2009)
- [11] J. Nelson, “Spatial and temperature dependence of magnetic memory induced by exchange couplings”, senior thesis, Brigham Young University, Department of Physics & Astronomy (2010)

Rare, Though it Shouldn't Be: A Virgin's Perspective on Sexual Activity

CoCo James, Andrea Santurro, and Spencer Blake
Salt Lake Community College

Abstract

In 2009, a survey was given at Salt Lake Community College (SLCC). This survey was a replication of a study previously given at Truckee Meadows Community College (TMCC) in 1988. It surveyed attitudes on first sexual experience of sexual intercourse. Because of the sensitive nature of the survey, accommodations were made to facilitate student anonymity. To avoid sampling only those who would be willing to indicate that they have had sex by participating in the survey, a section was created for those who had not yet participated in sexual intercourse. This section was not in the original TMCC survey. This work is related to the responses that the additional section created. The survey showed the reasons students gave for not participating in sexual intercourse. It also showed that just because that hadn't participated in intercourse, that didn't mean they were sexually inactive.

In 2009, a survey was given at Salt Lake Community College (SLCC) (James et al. 2009) This survey was a replication of a study previously given in 1988 at Truckee Meadows Community College (TMCC) in Reno, Nevada (Stroub 1988). Information was gathered in both surveys about students' first experience of sexual intercourse; the age at which it took place, the nature of the relationship in which it occurred, and the psychological imprint left on the participants. The 2009 SLCC survey was conducted to compare the responses from students on the other side of the Great Basin against those on the Wasatch Front, two decades later.

Because of the sensitive nature of the survey, accommodations were made to facilitate student anonymity. One of those accommodations forms and creates the foundation of this paper. To avoid sampling only those students who would be willing to indicate that they had had sex by participating in the survey, a section was created for those who had not yet participated in sexual intercourse. Thus, the survey could be passed out to all of the students,¹ regardless of their level of sexual experience. Those who had had sexual intercourse could fill out one section. Those who had not had sexual intercourse could fill out a different section. In this way, each respondent could participate in the survey without "announcing" to others around them (by participating in the survey) their own personal experience. This additional section was not in the original TMCC survey.

This section provided some interesting data on the attitudes of those who had not participated in sexual intercourse. It showed how they viewed themselves, as well as how they felt society viewed them. It revealed what sexual activities they had participated in. It disclosed some of their concerns and some of their reasons for abstinence. It also allowed the participants to express their attitudes about birth control and STDs. These responses have given insight into "the college virgin," at least those at SLCC.

Results

Three main attitudinal patterns emerged in the study. First, a majority of respondents listed religion as the main factor explaining why

¹ To create a random sample, classes were selected from SLCC General Education courses. This would give a broad-based student sample from the college. Classes that were selected included Anthropology, Education, English, History, Math, Philosophy, Psychology, and Sociology.

they had not participated in sexual intercourse. Second, just because a respondent hadn't participated in sexual intercourse did not mean that he or she was completely inactive sexually. Finally, these students were proud and felt a sense of accomplishment that they had abstained from sexual intercourse to that point in their lives.

The Virgin Label

Given the strong message that mass media sends to youth that sexual activity outside of marriage is expected and acceptable, why are some college students abstaining? Can they not find a suitable partner? Have they not yet had the opportunity? Are they waiting until marriage? Have they been afraid of contracting sexually transmitted diseases (STDs)? Do they have medical concerns? Or, have they adopted a different message than the one portrayed by mass media?

To the question "Why have you not participated in sexual intercourse?" each respondent could check all the answers that applied to them (Table 1). Consequently, the total percentage could and does equal greater than 100%. Respondents marked "waiting until marriage" more often than any other reason for their current celibacy (79.3%).² The next most common response (76.2%) was "religious beliefs," with just over three out of every four respondents indicating this as their reason for not having sexual intercourse. The next highest was "haven't found the right person," with just under half (41.5%) of the respondents selecting this reason.

By far, the most common attitude conveyed in the survey was a religious belief about abstaining from sexual activity. These results mirror those of other studies that focused on sexual behavior and religious attendance. Tim B. Heaton and Cardell K. Jacobson's 1994 study showed that strength of religious beliefs, along with frequency of church attendance, influenced and delayed first intercourse in the respondents. In 2003, A.M. Meier's work showed that adolescent girls who attended church regularly delayed participation in sexual intercourse. Also, studies have indicated that lower alcohol consumption is related to less risky sexual behavior and strongly held religious beliefs often lower alcohol consumption in individuals.

² 92.7% of this group indicated "religious beliefs" as their reason for waiting until marriage.

	Male	Female	Total
Religious beliefs	37.3%	38.9%	76.2%
Haven't had the opportunity	6.7%	5.2%	11.9%
Haven't wanted to	7.8%	16.1%	23.8%
Waiting until marriage	35.3%	44.0%	79.3%
Afraid	7.3%	11.4%	18.7%
Haven't found the right person	21.8%	19.7%	41.5%

In a follow-up question, “If religion was a factor, what is your religious affiliation?”, the Church of Jesus Christ of Latter-day Saints (LDS) was cited 68.9% of the time. Only 4.8% listed a faith different than LDS; however, it should be noted that 19.2% left that question blank. There were also 7.1% of the responses that were illegible.

The Bill Clinton Effect

Although the respondents reported that they had not yet participated in sexual intercourse, this did not mean that they had completely abstained from sexual activity. In fact, about two out of every three had participated in some form of sexual behavior (Table 2). Over half of the respondents (50.3%) reported “touch over clothing,” 40% reported “touch under clothing,” and 14.5% had participated in oral sex. Only 37.6% indicated that no sexual activity had occurred.

Another interesting attitude that emerged was in regards to birth control. The most common response from SLCC virgins about which form of birth control they planned to use someday was “the pill.” In contrast, the sexually experienced respondents reported the most common response as “condoms” (James et al. 2009). This difference might be in that the sexually active respondents viewed the condom as both birth control and a way of preventing STDs, whereas the virgins weren’t personally concerned with spreading or catching STDs since they weren’t sexually active.

None	37.60%
Touch over clothing	50.30%
Touch under clothing	39.90%
Mutual masturbation	17.10%
Masturbation	31.10%
Oral sex	14.50%
Phone/Internet sex	8.80%
Other	3.50%

Condoms are closely associated with the idea of “safe sex,” and a majority of the virgins in this study do not expect to be at risk, because of their own abstinence and the expected absence of STDs in their future partner. As one respondent put it when asked about STD prevention in the future, “He is going to be a virgin. ☺” In fact, as many people cited some form of abstinence as their plan to prevent STDs as those who cited condom use.

Proud to Still Have My Innocence

Most respondents held positive views about themselves for their virginity. They felt a sense of accomplishment. They stated that their decision to remain celibate was a good choice, one that set them apart from the crowd. It was a decision that would be beneficial to them in the future. When asked how they felt about their virginity, typical responses were “happy to be clean,” “proud to say I’m a virgin,” “glad I haven’t, just to say I have,” and “I am unique and not a tramp.” Some responses indicated a willingness to wait until marriage, “I’m excited to wait for that special occasion,” and “the smart choice: marriage.” Others noted the difficult nature of this choice, saying, “tough but worth it” and “curious but willing to wait.” Still others had a different view of celibacy, “I’m not some sex-addicted gigolo” and “I feel awesome for not giving in to vaginal tyranny.”

One interesting observation was the communicative nature of the respondents. They underlined words, wrote in the margins, drew symbols (such as smiley faces), and commented at length. They seemed very anxious to express that their virginity was the result of a personal choice, and not that they were socially awkward in some way. In general, they were intent on conveying their religious beliefs about sexual

activity and pride in their personal choice to abstain from intercourse. A handful of respondents felt diminished in some way by their lack of experience, but even they did not want to convey desperation. As one respondent put it, "Just because I haven't done it don't mean I haven't done crazy things."

Conclusion

One could conclude that religion plays a significant socialization role in forming sexual attitudes and influencing sexual behavior. Although mass media is a powerful influence, religion and its message of abstinence until marriage is still playing a role in the choices of about two thirds of SLCC students who remain celibate. These students fell outside of the societal norm, and they understood that. They were still willing to wait, and a good portion of them referred to their religious values as the reason. Specific religious vocabulary was used in their descriptions of their feelings, and specific religious practices were cited as factors in their decisions.

Being a virgin is not the same as refraining from all sexual activity. To a majority of the respondents, intercourse is much different from other forms of sexual activity. The respondents still considered themselves virgins if they had participated in activities such as mutual masturbation or oral sex. The term "sexual activity" is far broader than the term "sexual intercourse." Some respondents, who had participated in activities such as mutual masturbation and oral sex, described feelings of pride in their virginity. Still others had resisted more activities but felt less pride in their abstinence.

Nonetheless, those who embraced the abstinence message had internalized it. They fully recognized and acknowledged the difficulty of remaining celibate given the messages they receive on a daily basis; however, they expressed their desire to withstand those messages. They conveyed that their virginity was a deliberate choice and not the result of circumstance. Most of them see themselves as different, unique, and even special. As one respondent reflected, "Rare, though it shouldn't be."

References

James, CoCo, Cunningham, Richard, and Blake, Spencer. Survey of first experience of sexual intercourse. *Journal of the Utah Academy of Sciences, Arts, and Letters* 86:287-305, 2009.

Stroub, Dee. Survey of First Experience of Sexual Intercourse (Reno,

Truckee Meadows Community College, 1988).

Heaton, Tim B., and Jacobson, Cardell K. 1994. Race differences in changing family demographics in the 1980s. *Journal of Marriage and the Family* 15-290-308.

Meier, A.M. 2003. Adolescents transition to first intercourse, religiosity, and attitudes about sex. *Social Forces* 81(3): 103-25.

Americanization of Russian Culture and Its Effects on English Language Acquisition in that Country

Olga A. Pilkington

Dixie State College

Abstract

This paper examines linguistic and cultural changes that took place in post-Soviet Russia and analyzes them in relation to the acquisition of English as a foreign language in that country. The research reveals the link between Americanization of Russian culture and English language learning. According to the data collected for this project, Americanization of Russian culture has a positive effect on English language acquisition. The findings demonstrate that exposure to culture alone (not supplemented by formal instruction) is sufficient to acquire some English language vocabulary. The effect of Americanization is not generation specific and influences older and younger members of the society alike.

Introduction

Since the fall of the Soviet Union in 1991, Russian culture has been gradually westernized by the increased freedom of travel abroad, more frequent visits by European and American tourists, the availability of foreign media, and other factors, but mostly by the desire of the Russian people to catch up with the rest of the western world in the field of consumer goods and services. Cultural changes in modern Russia are numerous; many travelers to the country comment that by now big Russian cities are not much different from major American or European capitals. The most visible change in Russian culture, however, is the influence of modern American culture. Every major Russian city now has a MacDonald's, a multiplex cinema, shopping malls. Many people in Russia are just as curious about the lives of Hollywood stars as the Americans, and many people aspire to look and to behave just like their American idols.

The effects of globalization and Americanization are vast and complex. They can ignite debates on both sides of the ocean. It is not the purpose of this study, however, to analyze all the spheres of American influence on Russian culture; the focus of the present work is to look at the effects that Americanization is having on English language acquisition in Russia and to determine whether these influences are positive or negative, generation specific or universal.

First of all, it is explicit that the cultural changes that the Russian Federation has undergone in the last two decades have influenced the foreign language teaching practices. The availability of authentic teaching materials alone has had a huge positive effect on teaching English as a foreign language. Classroom acquisition of English changed from memorization of reading rules and irregular verbs to learning how to communicate using the language. English language teaching abandoned the use of anti-western propaganda and turned to western culture in general and American culture in particular for examples of language use in everyday life.

The language classroom in Russia is not the only place where one can get a good dose of Anglophone culture. The media has become saturated with Americanized television shows, copy-cat situation comedies, and Hollywood blockbusters dubbed into Russian, not to mention Russian versions of popular American magazines, translations of current best sellers, and the access to the Internet. Over the years, all of these have created a Russian culture that is heavily influenced and dependent on American tastes and views.

As Claire Kramsch, an expert on foreign language acquisition, points out, "It is a truism to say that teaching language is teaching cul-

ture” (p. 177), but does easy access to culture facilitate acquisition? This is the question I will attempt to answer in this study.

Method

Participants

This work is based on the information provided by three participants who all are native speakers of Russian and have been living in Russia all their lives. The participants include two adults and a child. The names of the participants have been changed for privacy purposes:

Nina, a 58-year-old chemist, has limited English language proficiency. She has studied English at a university as an undergraduate student as is currently taking English language classes for adults.

Aleksei, a 57-year-old professor of chemistry has never studied English.

Tatiana, a 10-year-old public school student has been learning English for three years in school.

Design

This was a qualitative research study based on interview data collected via phone conversations. Each participant was interviewed over the phone using focused conversation techniques described in Corbett (2003, pp. 121–123). These techniques include avoiding any kind of evaluation during the interview, encouraging the respondent to provide the information her or she wants instead of asking leading questions, and interviewing each subject several times. During the interview analysis, nonverbal responses such as voice pitch were also taken into consideration.

Each subject provided information relevant to different parts of the study. For example, the interview with Aleksei helped to determine whether someone who has never studied English could acquire English-language words exclusively by being exposed to Americanized culture. The interview with Nina provided data about adult learners of English and how they might be influenced by the Americanization of Russian culture. Tatyana’s responses serve as a examples of a new generation of English-language learners who grow up in the new Americanized culture.

Procedure

All of the interviews were conducted in Russian and later transcribed and translated into English. This work will use only English translation of the transcripts.

Subjects' interviews lasted about an hour each. During the interviews, the subjects were first prompted to talk about American influence on Russian culture in general and then to speak about any linguistic influence they noticed (if any). Later in the interviews, each subject was asked to respond to a few questions specific to his/her background in English-language learning.

Although the interviews differed depending on the subject's background, some questions were the same for all three subjects. Everyone was asked to provide specific examples of English-language acquisition through exposure to Americanized Russian culture. All participants were asked whether exposure to Americanized Russian culture had influenced their English-language acquisition.

Results

The major question of this study is whether the Americanization of Russian culture affects English-language acquisition in that country, and if so, whether the influences positive or negative. The interview data collected clearly demonstrate a link between modern Russian culture and English language acquisition. In the case of Aleksei, the acquisition of English vocabulary takes place unnoticeably and without formal instruction; to some extent, it is involuntary:

Aleksei: I watch the news and read [news articles] on the Internet. Most of the political and computer-related terms are not Russian words.

Interviewer: Really?

Aleksei: Yes, they are from English, because all of it comes from America. All computer terms and political terms are the same as in America.

Interviewer: What words are you talking about?

Aleksei: "Electorate," "impeachment," "speaker," "user," "account," "spammer."

Interviewer: Interesting... What does "account" mean in

Russian?

Aleksei: When you are on the Internet, you open a website and you have to sign in. "Account," it is like your information on the Internet. There is a Russian word for it, but it is not used. One has to say "account."

This interview fragment demonstrates several things. First of all, Aleksei has learned some English vocabulary without any formal instruction and solely from exposure to the Americanized culture. His explanation of the word "account" shows that the meaning in English and in Russian is identical, and it is very likely he will not have any trouble at all transferring this word from his Russian vocabulary into an English one if the need arises.

Second, Aleksei realizes that he has acquired words from a foreign language. Such vocabulary as "user," "account," and "spammer" is not considered Russian by the participant. In fact, he labels them "not Russian words" and demonstrated knowledge of their origin.

Lastly, Aleksei shows disappointment that the Russian word for "account" is not used any more. He acknowledged it not only verbally, but also by the change in the manner of speaking and the pitch of his voice. He sounded irritated and upset.

This last bit of information in combination with the fact that Aleksei has never shown interest in formal English language instruction allows one to suppose that, in his case, acquisition of English vocabulary is involuntary; however, Aleksei has acquired the words and uses them frequently whenever appropriate. Without this vocabulary, some of his daily activities such as watching the news and surfing the Internet would become frustrating since he would not be able to understand and process the information as effectively as he does now. Aleksei also noticed that English words have become popular in aspects of culture other than politics or computers. An example he gave from his everyday life illustrates how Russian culture becomes more and more Americanized as more English vocabulary flows into the Russian language. As Russia implements an education reform that will make the Russian higher-education system more similar to an American one, new words enter the lexicon of professors and students. Aleksei gives an example:

Aleksei: Everyone now says "campus." It is like in America. They call it "campus" now, not "student's town." Everything is being renovated, and it is now "campus."

This statement clearly links sociocultural changes in modern Russia with the increase in word borrowing from English. The use of newly borrowed words demonstrated by Aleksei allows classifying this new vocabulary as “nonce borrowings.” According to Paradis and Nicoladis (2007), nonce borrowings constitute a “single lexeme insertion into a phrase in a clause where all other elements come from the other language” (p. 284). This is exactly the use that Aleksei himself demonstrates, and he suggests that others do the same.

In Aleksei’s mind, structural renovations of universities are linked to lexical borrowings from English. Because renovations are done in an American style, it is not surprising that the new labels are borrowed from English.

While it is obvious (as Aleksei demonstrates) that to function properly in a modern Russian society one has to acquire some English-language vocabulary, it is not as clear whether the American influence on Russian culture and language is of any assistance to those who learn English with the help of formal classroom instruction.

The interviews with Nina and Tatyana provide the data necessary to answer this question.

For Nina, “It is easier to study words that one has already heard. Easier to comprehend something that sounds familiar.” Tatyana has a similar view, “Sometimes the teacher tells us the new words to learn, and I know I have already heard one or two of the words, but I don’t know how to translate. I just know that they sound familiar, and it is easier to remember them when I learn the translation.”

Both comments indicate that exposure to English-language vocabulary in everyday life is beneficial when it comes to formal instruction. In some ways, knowledge of American culture and knowledge of even limited English vocabulary that inevitably comes with it create a sort of background knowledge that, once accessed, speeds up acquisition. What both Tatyana and Nina describe are examples of cognitive strategies such as auditory perception, elaboration, and transfer. All of them are based on tapping into previous knowledge and using it to cope with the new information (Brown, 1994, p. 177).

The Americanization of Russian culture has provided not only an infusion of random English words into Russian language, but it has also accomplished much more. It has minimized the perceived social distance between the two cultures and, by doing so, eased the process of acquisition (Acton, 1979, cited in Brown, 1994, pp. 179–180). Perceived social distance is the attitude one has about the differences between two cultures. The shorter the perceived social distance, the easier it is to learn a foreign language (Brown, 1994, p. 180–181).

During the interviews, Nina and Tatyana demonstrated different ways of presentation of self. Nina always used the first-person singular pronoun when discussing her experience, even though she attended an English-language class with 10 other people. Tatyana preferred to use the first-person plural pronoun when talking about her experiences. This allows an assumption that, while Nina's English-language learning experience is associated with her individual discoveries of American culture, Tatyana's experiences are linked to school and to classroom acquisition, but not to her individual observations. Different realizations "of communicative orientation" can not only signal sociocultural differences between participants but can also help determine the participants' views of the subject discussed (Corbett, 2003, p. 124).

While Tatyana associated learning English only with her classroom experiences, she demonstrated knowledge, usage, and acquisition of the English language outside the classroom as well. During the interview she singled out several English words as "every day" and "common" to her. These words were "shopping," "Okay," and "cool." Tatyana also indicated that on several occasions in the company of her classmates, she used code-mixing (mixing two or more languages in speech) incorporating the above words. She claims to have done so for comic effect. When asked where she learned these words, Tatyana responded that she could not remember; however, she provided an example of how she first encountered the word "shopping"—it was written on one of her T-shirts and her mother told her what it meant.

The use of codemixing and the inability to clearly identify the origin of acquisition of certain words indicates that they are very likely entering the vocabulary through Americanized Russian culture, as the "shopping" example demonstrates.

Tatyana also showed an interesting notion not expressed by other participants that American culture is not foreign to her. In fact, in some instances, she failed to separate American/Western and Russian cultures. For example, she showed great surprise when she was told that *Finding Nemo*—her favorite animated film—was a Disney cartoon. She said she did not know that. To her it was Russian. Tatyana also did not see Harry Potter as an English boy; in her mind he was not a foreigner.

On the other hand, Aleksei and Nina—the older participants—drew clear lines between Russian and foreign. Aleksei was aware of the origins of the new words in his vocabulary and showed open remorse for the abandonment of their Russian equivalents. Nina's examples of separating Russian and foreign in her environment include an example of visual culture. When asked about the textbook she used in her English class, Nina said that she did not like it because of the way it was organized. She pointed out that she was unhappy about the text being

separated into a workbook containing exercises and a textbook containing grammar explanations. She said that this separation so popular in Western published English as a Second Language materials felt foreign to her and was inconvenient. She said it would have been easier for her to study if the new grammar and the exercises were side by side in one book—the way that it common for Russian-language materials.

Both Nina and Aleksei noticed that Americanization of Russian culture tended to elevate the status of English and to diminish the status of the Russian language. The examples they gave included names of new businesses that used English words such as “Elegance,” “Hollywood,” and “Saloon” instead of Russian words. Aleksei also said that most of the time such names would be spelled with a combination of Cyrillic and Roman alphabets. As Corbett (2003) explains, it is common for a westernized culture to use the Roman alphabet “for its pictorial qualities” (p. 159). He also points out that, “In cultures aligned to the West, English is often used to glamorise a product or service being sold to the public” (p. 160).

Discussion

Judging by the responses and the experiences of the participants in this study, the Americanization of Russian culture has a definite effect on the English-language acquisition in that country. All of the participants indicated some degree of familiarity with English that they have acquired through the surrounding environment. Aleksei is probably the best example since he has never studied English formally and his knowledge of English vocabulary is due exclusively to the Americanization of the Russian society.

While Tatyana is the one who demonstrated the strongest connection between modern Russian culture and English-language acquisition, the fact that Nina also noticed some changes in her English studies indicates that the effect is not generation specific. However, the younger members of the Russian society probably benefit the most because they grow up in the Americanized culture and accept some of its Anglophone elements without questioning.

Corbett (2003) suggests that “Information exchange is culturally shaped” (p. 127). Modern Russian society is a good example of this statement. As Aleksei indicated, it has become impossible to exchange and to process information without the knowledge of at least some English-language vocabulary. Americanization of Russian culture has brought about not only social, but also linguistic changes. According to the Whorfian hypothesis, grammar can influence our thought process and thus language can in some ways dictate culture, but the current

cultural situation in Russia demonstrates the opposite—cultural changes dictate linguistic ones.

The opinions about cultural changes in Russia differ; however, none of the participants indicated animosity toward Americanization of the culture in general. Aleksei was the only one who voiced his dissatisfaction with the usage of nonce borrowings such as “account” and “campus.” An example of the same participant’s acceptance of other aspects of Americanized Russian culture, on the other hand, is his favorite television program—*Happy Together*—a Russian-language version of the American sitcom *Married with Children*. As Clifford J. Levy (2007) describes it, “The show is an authorized copy of the American sitcom ‘Married With Children,’ with a Russian cast and dialogue but scripts that hew closely to those of the original” (p. 1). *Happy Together* is not the only recent example of the popularity of American sitcoms in Russia. *My Fair Nanny* (*The Nanny*) and *The Voronins* (*Everybody Loves Raymond*) are now part of Russian culture. When such shows air, it is not a secret that they are copied from American originals; in fact, very often viewers get so interested in the prototype that the Russian producers discuss inviting the original stars.

Cultural and linguistic changes go hand in hand. As Seelye (1994) writes, “When for one reason or another members of one language community are forced to function either within or alongside another language, both their language and way of life inevitably change” (p. 4). As Russian participants demonstrate, “cultural community” can be easily substituted for “language community,” and “another language” can become “another culture” without altering the meaning of Seelye’s phrase. Seelye also suggests that in the situation he describes above there is a “considerable positive correlation between linguistic change and social change” (p. 4). Again, as the participants in the study indicate, “considerable positive correlation” also exists between cultural change and linguistic opportunities for the people of new Russia.

It is clear that there is a correlation between the Americanization of Russian culture and English-language acquisition. This correlation is positive and not constricted by generation divides. It can be explained by the sensitivity of community members to language patterns around them. As Paradis and Nicoladis (2007) demonstrate, even preschool children are old enough to sense language patterns of their communities (p. 294). It is not surprising that adults follow the same path and try to acquire and use language patterns of the surrounding community.

The Americanization of Russian culture has provided Russian society with new language patterns, which are easily assimilated and have had a positive effect on English-language acquisition in Russia.

References

Brown, H. D. (1994). *Principles of language learning and teaching*. Englewood Cliffs, NJ: Prentice Hall Regents.

Corbett, J. (2003). *An intercultural approach to English language teaching*. Clevedon: Multilingual Matters LTD.

Kramsch, C. (1993). *Context and culture in language teaching*. Oxford: Oxford University Press.

Levy, C. J. (2007). Still married, with children, but in Russian. *The New York Times*, September 10. Retrieved November 30, 2008, from http://www.nytimes.com/2007/09/10/world/europe/10sitcom.html?pagewanted=1&_r=2&hp

Paradis, J. and Nicoladis, E. (2007). The influence of dominance and sociocultural context on bilingual preschooler's language. *The International Journal of Bilingual Education and Bilingualism*, 10(3), 277-297.

Seelye, H. N. (1994). *Teaching culture: Strategies for intercultural Communication*. Lincolnwood, Illinois: National Textbook Company

Reassessing American Foreign Policy Amidst the Maelstrom: The Last Superpower? Revisiting the Paradigm of Imperial Decline

G. Michael Stathis

Southern Utah University

Abstract

The economic and political maelstroms of the past few years have not only brought into question the status of the United States as a superpower, but have raised questions about the very nature of what we have called a superpower. While there is still much to admire in the United States as a great power one might be led to ask whether it is the last superpower. Once again Paul Kennedy's paradigm of overextension, or imperial overstretch and decline, a paradigm of imperial decline if you will, have come into focus, and again we turn to Samuel P. Huntington's more optimistic response to ponder the potential fate of the empire of liberty. And should the United States fall victim to Kennedy's theory of imperial demise, will another superpower emerge? Or have we reached a point when the necessary elements of superpower status have proven too taxing for even the most innovative of powers? Huntington postulated that unlike other great powers that have come and gone, the United States has had that rare ability to "renew" its power and itself and that outcome is likely to hold true at least one

more time due in some part to the audacity of hope reflected in the new American President. But beyond that the realities of the new century will almost certainly prove too overwhelming to allow the birth of any new superpowers. Two other questions have emerged to further complicate this issue: should the paradigm of imperial decline prove sound will it lean towards the traditional notion of gradual decline and fall, or as Niall Ferguson has recently postulated will it come quickly as a "thief in the night," and secondly, as teachers and scholars how do we react academically to the paradigm of decline in the shadow of the recent maelstrom? Clearly the paradigm of imperial decline remains a relevant topic. And history seems to have favored the process of gradual decline rather than a precipitous and quick fall. Interestingly, as a recent contributor to the literature of imperial decline has noted, we have the enviable advantage of historical perspective, and that should form the better part of motivation for academics regarding this vital issue.

Introduction: Revisiting the Paradigm of Imperial Decline

The economic and political maelstroms of the past few years have not only brought into question the status of the United States as a superpower but have also raised questions about the very nature of what we have called a superpower. While there is still much to admire in the United States as a great power, one might be led to ask whether it is the last superpower? Once again Paul Kennedy's paradigm of overextension, or imperial overstretch and decline, a paradigm of imperial decline, if you will, have come into focus, and again we turn to Samuel P. Huntington's more optimistic response to ponder the potential fate of the empire of liberty. And should the United States fall victim to Kennedy's theory of imperial demise, will another superpower emerge? Or have we reached a point when the necessary elements of superpower status have proven too taxing for even the most innovative of powers? Huntington postulated that unlike other great powers that have come and gone, the United States has had that rare ability to "renew" its power and itself and that outcome is likely to hold true at least one more time due in some part to the audacity of hope reflected in the new American President. But beyond that, the realities of the new century will almost certainly prove too overwhelming to allow the birth of any new superpowers. Two other questions have emerged to further complicate this issue: should the paradigm of imperial decline prove sound, will it lean towards the traditional notion of gradual decline and fall, or

as Niall Ferguson has recently postulated will it come quickly as a “thief in the night,” and secondly, as teachers and scholars, how do we react academically to the paradigm of decline in the shadow of the recent maelstrom?

Clearly the paradigm of imperial decline remains a relevant topic of discussion and concern including focus on current and future prospects for the United States in the shadow of the recent maelstrom. It remains to be seen whether the era of the superpower is passing, as there are limited prospects for any new contenders for that vaunted title. As to whether imperial decline and fall comes quickly or through a long process, history still seems to favor the latter case. Interestingly, as one of the more recent contributors to the literature of imperial decline has noted, we have the enviable advantage of historical perspective, and that should form the better part of motivation for academics regarding this vital issue.

The Paradigm of Imperial Decline

We begin with what Paul Kennedy called *imperial overstretch* resulting from overextension either geographically, economically, or militarily, which inevitably leads to the exhaustion of vital domestic resources, decline and fall.¹ As a later commentator on the subject, Piers Brendon, has put it, “...the ascendancy of states or empires results from the superiority of their material resources, and that the wealth on which that dominance rests is eroded by the huge military expenditures needed to sustain national or imperial power, leading inexorably to its decline or fall.”² Kennedy was, of course, not the first chronicler of declinist literature. Indeed, the subject was touched on in the ancient world by Thucydides, Polybius, and Tacitus, while in Islamic tradition Ibn Khaldun gained notoriety both in his realm and in the West. Clearly, the iconic version of this paradigm was Edward Gibbon (did he really blame the Christian right for Rome’s decline and collapse?). Both Oswald Spengler and Arnold Toynbee brought the discussion into the 20th century, where lately a host of writers have reexamined it, including Kennedy, Niall Ferguson, and Brendon. Recent motivation has had much to do with the decline of British power, the decline and col-

¹Paul Kennedy, *The Rise and Fall of the Great Powers: Economic Change and Military Conflict from 1500 to 2000* (New York: Random House, 1987, note especially the chapters *The Soviet Union and Its “Contradictions,”* and *The United States: The Problem of Number One in Relative Decline*, 488-514, and 514-535.

²Piers Brendon, “Like Rome Before the Fall? Not Yet,” *The New York Times*, February 25, 2010, 27 (A).

lapse of the U.S.S.R., speculation about the state of the United States, and, in a broader context, the fate of great powers altogether.

A New Twist on an Old Theme

Niall Ferguson recently returned to the subject of the *paradigm of imperial decline* in his generally impressive piece “Complexity and Collapse: Empires on the Edge of Chaos.”³ Ferguson is generally accurate if not complete in his short look at the recognized modern literature regarding the paradigm of imperial decline, including Henry St. John, First Viscount Bolingbroke in 1738 (*The Idea of a Patriot King*), Giambattista Vico in *Scienza nuova* (1725), Edward Gibbon, (*The History of the Decline and Fall of the Roman Empire, 1776–1778*), the various works of Frederick Hegel and Karl Marx, Ostwald Spengler (*The Decline of the West, 1918–1922*), the work of Arnold Toynbee (*A Study of History, 1934–1961*), Paul Kennedy’s *The Rise and Decline of the Great Powers* (1987), and, more recently, Jared Diamond’s *Collapse: How Societies Choose to Fail or Succeed* (2005). Not unexpectedly, he leaves out a classic non-Western perspective on the subject in Ibn Khaldun’s *Muqaddimah (Introduction to History)*, some popular but very interesting images in film such as *The Fall of the Roman Empire* (1964), and *Apocalypto* (2006), as well as some recent and more optimistic views by Samuel P. Huntington, Fared Zakaria, Piers Brendon and even Paul Kennedy, which prove to be interesting omissions.⁴

Ferguson rightly points out that most of this declinist literature cites multiple causes and gradual or prolonged decline and eventual fall, but he also suggests that at least in some cases it was not an instance of protracted decline and fall at all, but rather something accelerated and sudden “like a thief in the night.”⁵ And, of course, the suggestion is that this may apply to the United States. While he, and others such as Paul Kennedy, may yet be proved right in general, imperial fall usually does not come overnight, or as Ferguson puts it in his concluding statement: “A defective brake or a sleeping driver can be all it takes to go over the edge of chaos.”⁶ In truth, even Ferguson speaks of sudden or quick fall in terms of a human generation or even a century, which is hardly quick. Even the artistic device that he cleverly uses as tapestry for his argument belies the idea of suddenness. The

³ Niall Ferguson, “Complexity and Collapse: Empires on the Edge of Chaos,” *Foreign Affairs* 89: 2 (March/April, 2010): 18–32.

⁴ *Ibid.*, 19 and 26.

⁵ *Ibid.*, 22.

⁶ *Ibid.*, 32.

five paintings by Thomas Cole generally entitled *The Course of Empire* (1833–1836) portray the more traditional notion of gradual rise, decline, and fall.⁷ Moreover, the suggestion that Rome's fall could be described as relatively sudden from 406 to 476, less than a century and a generation even at that time, essentially ignores the fact that the Western Empire by 400 was little more than a shadow of what it had been some two centuries before under Trajan or Marcus Aurelius. Indeed, many historians use the death of the latter as a convenient point to begin the discussion of Roman decline and fall. A better historical example of a precipitous imperial fall would be the case of the Aztec Empire as the result of a thief in the night and a true clash of civilizations (1521). Still, Ferguson makes a case that the United States may prove an exception to the idea of gradual decline in persuasive terms and must be observed at least as seriously as Huntington's reaction to Kennedy's original suggestion of American decline. Ferguson offers an unexpected, and yet plausible, premise that, if nothing else, refreshes the academic discussion.

Of the more recent academic proponents of the paradigm of imperial decline, Paul Kennedy is arguably the most influential if not iconic, while Jared Diamond has proven the most recently engaging because of his emphasis on what might be called *green* issues involving agriculture, land use, ecology, and other more traditional reasons for decline such as war and civil disruption.

Ferguson's reference to Cole's paintings, *The Course of History*, proved an apt symbolic backdrop to frame his discussion, but today the most common source for popular imaginings of the paradigm of decline are to be found in film. Two of the more interesting entries are Anthony Mann's *The Fall of the Roman Empire* and Mel Gibson's *Apocalypse*, the former representing the more traditional explanations of decline and fall, while the latter at least touches on more recent insistence on *green* causes.

The Fall of the Roman Empire, the 1964 film epic from producer and movie impresario Samuel Bronston and director Anthony Mann, was opulent and well received by critics and proved to be a literate (thanks in part to Will Durant who served as a consultant) entry into the sword and sandal films of the period. The film opens with a prologue that is somewhat simplistic but not entirely inaccurate and clearly emphasizes the sub-paradigm of gradual decline.

⁷ Cole's paintings include: *The Savage State*, *The Arcadian or Pastoral State*, *The Consummation of Empire*, *Destruction*, and *Desolation*.

Two of the greatest problems in history are how to account for the rise of Rome and how to account for her fall. We may come nearer to understanding the truth if we remember that the fall of Rome, like her rise, had not one cause but many and was not an event but a process spread over 300 years. Some nations have not lasted as long as Rome fell.⁸

The first half of the film takes place, more or less, on the Danube frontier in 180 A.D., where Emperor Marcus Aurelius led Roman legions against Germanic tribes. Later, the focus shifts to the East and problems with Persia (Iran). All of this is complicated by the death of Marcus Aurelius and the accession of his son Commodus. The thesis of this film, if an epic film really has such a thing, is that a combination of events—pressures on the northern frontiers from Germanic tribes and in the East from the Persians—coupled with the untimely death of a one of Rome’s five good emperors, Marcus Aurelius, and the disastrous reign of his less than dynamic son, Commodus. There are even some brief references to green causes: drought, famine, and population growth. Again, this is more or less accurate and true to the prologue regarding a process and multiple causes.

One might view this film from today’s perspective and create an overly clever scenario regarding the United States— substituting Cold War pressures in Europe, the impact of which continued (contributing to a growing national debt and other financial pressures) long after the collapse of the Soviet Union in 1991, pressures in the East, including potential regional threat from Iran, and the election of a president who proved to be less than dynamic, George W. Bush. We end the tempting comparisons here. After all, George H.W. Bush was no Marcus Aurelius, and the United States is one of those “nations” that has not yet lasted as long as Rome fell. Still, a case can be made for a combination of events and processes over almost 10 years that have weakened the United States considerably: the coincidence of the disastrous presidency of George W. Bush; the terrorist acts of 9/11; war in Afghanistan; an ill-advised invasion of Iraq, clearly a war of *choice*; and the emergence of the Islamic Republic of Iran as a significant, but troublesome, power in the Persian Gulf, in great part the result of Bush’s war with Iraq. At the very least, it could be said that the United States inherited by Barack Obama as President of the United States was a world

⁸ *The Fall of the Roman Empire*. Anthony Mann, dir. and Samuel Bronston, prod. 185 mins. Samuel Bronston, 1964; The Miriam Collection, 2008, DVD.

away from that which George W. Bush took from William Jefferson Clinton's hands.

Gibson's evocative *Apocalypso* cited superstition, blood lust, and fear as elements of decline in a late Mayan city-state. And, of course, there is the contrast of these negative factors in the urban city versus the comparative pristine family life of outlying tribes in the rainforest. As we see in a puzzling climax, Gibson totally dismisses earlier portrayals of the Maya as benign astronomer/priests; surely the Mayan priests would have had full knowledge of the solar eclipse that arrives as *deus ex machina* to fundamentally change the course of the story. Gibson is guilty of other historical shortcomings as well, including obvious errors in the time line: the zenith of the Mayan city-states passed several hundred years before the arrival of the Spaniards. Gibson's final answer to the cautionary tale of potential apocalypse, returning to the forest, may be clichéd, but it too gives some resonance to other green arguments.

Even with some critical weaknesses, Paul Kennedy's thesis based on the overextension of great powers, what he called *imperial overstretch*, is once again of interest. On the one hand, there was sound cause for criticism when Kennedy published his work, *The Rise and Fall of the Great Powers*, in 1987. For one thing, he speculated as to events from 1987 to 2000 and proved to be off target as far as the United States was concerned (as pointed out by Huntington in his important counterpoint regarding the United States as discussed below) though fairly accurate with the Soviet Union.⁹ The United States made significant strides towards economic stability under William Jefferson Clinton, who balanced the national budget (indeed, produced surpluses) and began a process to pay off the national debt. Lest it be forgotten, it was essentially the years between 1991 and 1999 that inspired reference to the "American moment." On the other hand, it became quite tempting to reconsider Kennedy from 2006 on. After the invasion of Iraq in 2003, it became all too clear that the United States was overextended militarily, politically, and economically. Embroiled in essentially three wars, an unprecedented event, the "War on Terror," the war in Afghanistan, and the war in Iraq, failing international coalitions and associations, growing trade deficits, and what would amount to a doubling of the national deficit and debt, by 2008 the *Empire of Liberty* was on the verge of catastrophe. Perhaps Kennedy was just a bit pre-

⁹Paul Kennedy, *The Rise and Fall of the Great Powers: Economic Change and Military Conflict from 1500 to 2000* (New York: Random House, 1987, note especially the chapters *The Soviet Union and Its "Contradictions,"* and *The United States: The Problem of Number One in Relative Decline*, 488-514, and 514-535.

mature in his analysis. Indeed, much of what Kennedy had warned about in his notion of imperial overstretch seemed to be coming about.¹⁰

There is little argument that Kennedy was fairly prescient in forecasting the demise of Soviet power, although he could not have foreseen the unexpected details of that stunning event. Essentially he hit the major point and was so much closer to the truth than the later *Reagan won the Cold War* scenario. Overextended militarily, politically, and economically the Soviet Union was hardly in a position to make the dramatic transitions called for by Mikhail Gorbachev to compete in a world that had come to demand a much higher degree of financial and economic competition than the Soviet state was capable of achieving. Gorbachev's bold efforts at reform failed, and the Soviet Union dissolved in 1991. Certainly, this was a case of imperial overstretch. The irony, of course, was in how the so-called "evil empire" came to an end—a failed coup, simple refusal to sign the Treaty of Union, and a presidential resignation on Christmas Day. "Never before has there been a case of an empire that caved in without a war, revolution, or invasion."¹¹ Or as George C. Herring described it "...an event as momentous in its ramifications as it was anticlimactic in its occurrence."¹²

Jared Diamond represents a fairly recent interpretation of the paradigm of imperial decline, one that tends to focus on so-called green causes. In *Collapse: How Societies Choose to Fail or Succeed*, Diamond examines a number of early (and some more recent) societies from an ecological point of view, "...human environmental impact and climate change intersecting, environmental and population problems spilling over into warfare...and societies collapsing swiftly after attaining peak population numbers and power."¹³ Not all of them fit under the title *imperial*, but several do, and perhaps the most intriguing case

¹⁰ *Ibid.*, 514-515.

¹¹ Sir Isaiah Berlin quoted in Walter LaFeber, *America, Russia, and the Cold War, 1945-1996*, 8th ed. (New York: McGraw-Hill, 1997), 347.

¹² George C. Herring, *From Colony to Superpower: U.S. Foreign Relation Since 1776* (Oxford: Oxford University Press, 2008), 913.

¹³ In reference to the collapse of the Chaco Canyon Anasazi and the Long Hours Valley Anasazi, Diamond concluded "Despite these varying proximate causes of abandonments, all were ultimately due to the same fundamental challenge: people living in fragile and difficult environments, adopting solutions that were brilliantly successful and understandable 'in the short run,' but failed or else created fatal problems in the long run, when people became confronted with external environmental changes or human-caused environmental changes that societies without written histories and without archeologists could not have anticipated." See Jared Diamond, *Collapse: How Societies Choose to Fail or Succeed* (New York: Penguin Books, 2005), 137 and 155.

is that of the Maya. Until the ruins of several of Mayan city-states were rediscovered by John Stephens and Frederick Catherwood in 1839, Mayan imperial power and civilization had not only fallen but had virtually disappeared in the subtropical forest and had very nearly been forgotten altogether. Ironically, as the Spaniards led by Hernán Cortés marched through the Central Petén, what had been the Mayan heartland, in 1524–1525, he passed within miles of the early Mayan urban centers of Tikal and Palenque without noticing the well-preserved ruins because they were covered by the jungle, and there were no people there to tell him of them. The formula for the Maya's decline and fall was long term, gradual, but complete.

They did damage their environment, especially deforestation and erosion. Climate changes (droughts) did contribute to the Maya collapse, probably repeatedly. Hostilities among the Maya themselves did play a large role. Finally, political/cultural factors, especially competition among kings and nobles that led to a chronic emphasis on war and erecting monuments rather than on solving underlying problems, also contributed.¹⁴

Ironically, the Maya, whose astronomical and mathematical genius had created their Long Count calendar, were unable to foresee the ultimate damage they were doing to their own world. They forsook long-term survival for short-term wealth and glory. What was left of the people in depopulated cities eventually did go back to the forest, Gibson was partially right, abandoning the unsustainable metropolis. Curiously, the Maya never formed a single empire, because no single Mayan city-state or alliance could grow enough food to feed such an endeavor.

The relevance of Diamond's case studies to modern society, especially the United States, will no doubt be questioned given what could be called their pre-modern nature, whereas Paul Kennedy focused on historical examples that existed in the modern era. But both emphasized elements of imperial overstretch, and both presented cases that noted long-term processes or *longevity*. Kennedy's case for the United States seemed to have lost validity in the late 1980s and the 1990s as it actually grew in power and seemed to validate Samuel P. Huntington's critique of the Kennedy paradigm in 1988/1989.¹⁵ But in 2010, it may

¹⁴ *Ibid.*, 159-160.

¹⁵ Samuel P. Huntington, "The U.S.-Decline or Renewal?" *Foreign Affairs* 67: 2 (Winter 1988-1989): 76-96.

be Huntington's notion of a dynamic United States that unlike other great powers possesses the ability to renew its power that seems to be in question.

Some More Optimistic Scenarios

Well into Barack Obama's second year as President of the United States, domestic news may be improving but prospects for continued annual federal deficits are grim, as is news on employment. Meanwhile, in foreign affairs, there may be a promise for an end in Iraq within the year, but Afghanistan still smolders, while aspects of the war on terror have begun to destabilize Pakistan, and there are signs of *al-Qa'ida* beyond the Persian Gulf and American attacks have followed. Overstretch, indeed. Instead, this paper turns to Kennedy's chief critic, Samuel P. Huntington.

For years, PBS ran a promotion for its laudable series *The American Experience* showing images from different decades in American development backed by the wondrous music of John Barry from the film "Dances With Wolves." The narration promoted the notion that the United States was that unique country that had the capacity to continually reinvent itself, a point that has proven to be true more or less.

Certainly this was the general point that Huntington promoted in his refutation of Kennedy regarding the United States in his notable piece "The U.S.—Decline or Renewal?" in 1988. Despite the market crash of October 1987 and the enormous sense of pessimism that followed, Huntington posed the simple question "Is the United States fundamentally a nation in decline? Or is it in the midst of renewal?"¹⁶ At the time, Huntington suggested that far from being a great power in decline, the United States was in the process of what he considered a fairly regular process of "renewal."¹⁷ Citing the necessary economic and financial figures at the time, he conceded that the United States had hit a major block in the road, actually coming close to supporting Kennedy's *overstretch* thesis, something that was likely to reoccur, but also held that unlike other great powers described by Kennedy, the United States was fundamentally different and therefore not as prone to the outcome of decline and fall.

Declinist literature sets forth images of a nation winding down economically, living beyond its means, losing its competitive

¹⁶ *Ibid.*, 77.

¹⁷ "The image of renewal is far closer to the American truth than the image of decadence purveyed by the declinists." *Ibid.*, 76-77.

edge to more dynamic peoples, sagging under the burdens of empire, and suffering from a variety of intensifying social, economic, and political ills.¹⁸

Huntington offered something of his own great power model, countering Kennedy's assessment of the United States and generally a host of negative opinions quite secure in contemporary financial/economic fact. The two fundamental elements of this model emphasized the ability to renew national power and the diversity or dynamism of the sources of a state's power.

The ultimate test of a great power is its ability to renew its power. The competition, mobility, and immigration characteristic of American society enable the United States to meet this test to a far greater extent than any other great power, past or present. They are the central sources of American strength.¹⁹

Unlike any other power of the time, Huntington believed, "...American strength is peculiarly multidimensional," that is, not singularly based on either economic power, political power, or military power, and possesses the ability to adapt, to shift emphasis according to changing national and international condition.²⁰ Huntington also held that the continuation of American superpower status would accrue according to the simple fact that there was unlikely to be an emergence of an "alternative hegemonic power" in the 21st century. In this Huntington was almost certainly correct.²¹ His ultimate conclusion was simple enough, "...the United States is less likely to decline than any other country. It is distinguished by the openness of its economy, society, and politics. Its engines of renewal are competition, mobility, and immigration."²² It is interesting to consider these "engines of renewal" from 2001 to 2010.

Huntington may actually prove to be right in his assessment of the United States, but any power, especially one that could be described as overextended, is vulnerable to the kind of scenario that might resemble the so-called *perfect storm*, that unexpected coincidence of events where the sum is greater than the parts. Still, the United States does indeed have that innate capacity to reinvent itself every now and again,

¹⁸ *Ibid.*, 77.

¹⁹ *Ibid.*, 90.

²⁰ *Ibid.*, 90-91.

²¹ *Ibid.*, 92.

²² *Ibid.*, 89

often amounting to a true renewal of national power. This is evident to a great extent in the events of the past five months. The election of 2008 on many levels marked a seismic change in the American political landscape, bringing new economic approaches, dramatic alterations of domestic policies, and significant shifts in foreign policy. All told, it could amount to changes that verge on the revolutionary. But only time will tell if the hope and skill of a new administration is equal to the myriad challenges facing the United States and the world at this time, and if Huntington's older premise of American renewal will again restore American power.

The United States is not immortal, and American preeminence is not inevitable. Yet, some states endure for extraordinary lengths of time, and little reason exists to assume that recent prophecies of American decline are more accurate than earlier ones. Every reason exists, however, to encourage belief in such prophesies in order to disprove them. Happily, the self-renewing genius of American politics does exactly that.²³

Huntington's earlier reference to the "self-renewing genius of American politics" seems to be reflected in some more recent voices, if not in a few recent events.

While Fareed Zakaria has offered a broad spectrum of problems facing the United States as a superpower, he has nevertheless concluded, not unlike Huntington, that it remains a power apart from others, "...such problems must be considered in the context of an overall economy that remains powerful and dynamic."²⁴ He also notes other elements of American power: higher education, a vibrant demography, flexibility, resourcefulness, and resilience.²⁵ The primary problem identified by Zakaria is what he calls *dysfunctional politics*. He describes the United States as "A can-do country...saddled with a do-nothing process, designed for partisan battle rather than problem solving."²⁶ Zakaria notes that the so-called unipolar moment may fade, and clearly many dimension of power are shifting away from the United States, but it is not about to happen suddenly, and it may be that ultimately the shift of many of these elements to the rest of the world may still favor the United States,

²³ Ibid., 96.

²⁴ Fareed Zakaria, "The Future of American Power: How America Can Survive the Rise of the Rest," *Foreign Affairs* 87: 3 (May/June): 30.

²⁵ Ibid., 31-39.

²⁶ Ibid., 41.

The world is changing, but it is going the United States' way. The rest that are rising are embracing markets, democratic government (of some form or another), and greater openness and transparency. It might be a world in which the United States takes up less space, but it is one in which American ideas and ideals are overwhelmingly dominant.²⁷

This sentiment is even echoed by the political right. Recently, T. Boone Pickens said, "This is the greatest nation in the world. When we get off course, we have the ability to change and do it quickly."²⁸

Neil Ferguson finally suggests that we may be approaching a world without a superpower of any kind, neither a unipolar nor multipolar world. "The future, in short, might prove for a time to be apolar, a world without even *one* dominant imperial power, the 9th century, perhaps, but without the Abbasid caliphate."²⁹ But this scenario would still leave the United States in the mix.

Even Paul Kennedy concedes that in some areas the *American moment* may not be quite over,

It is reasonable to argue that the United States' military power, being so massive, will face few direct challenges in the years ahead, even if it will always find it tricky to handle asymmetric threats from terrorists and other nonstate actors.³⁰

Of course, Kennedy remains cautious about the United States' economic power where he suggests that America has "...reentered a multipolar world after an unusual half century of its own preeminence," and the United States' *soft power*, which he emphasizes was "frittered away" with the "flawed foreign policies of the past seven years."³¹ Amazingly, Kennedy is now not quite ready to condemn the United States to historical heap of fallen great powers, despite the emerging calamities of 2008, which leaves us to speculate about the possibility of American *renewal*.

Perhaps the most recent commentary on the paradigm of imperial decline also happens to fit into this more optimistic niche. Piers Bren-

²⁷ *Ibid.*, 43.

²⁸ Quoted in *Esquire* 151: 2 (February 2009): 97.

²⁹ Ferguson, *Colossus: The Price of America's Empire* (New York: The Penguin Press, 2004), 298.

³⁰ Paul Kennedy, "The Distant Horizon: What Can 'Big History' Tell Us About America's Future?" *Foreign Affairs* 87: 3 (May/June 2008): 132-133.

³¹ *Ibid.*

don, the respected British historian who has made his own mark in declinist literature with *The Decline and Fall of the British Empire: 1781-1997*, recently defended Vice President Joseph Biden's rejection of projections of American decline, "...prophecy that we are going to be a great nation that has failed because we lost control of our economy and overextended." Essentially Brendon agrees with Biden that reports of America's demise are greatly exaggerated.³² He also notes significant differences in the respective cases of the decline of other great powers and the modern case of the United States, particularly this oft-cited example of Rome,

Rome was prone to internecine strife whereas America is constitutionally stable. Rome was overwhelmed by barbarians whereas America's armed forces are so powerful as to prompt dreams of what is known in military doctrine as "full spectrum dominance." Even in an age of terrorism and nuclear proliferation, it is hard to visualize an attack on America as devastating as that inflicted by Vandal, Goths, and Huns on Rome.³³

Brendon also gives some cautionary, but more or less positive, advice on what the United States should do to avoid possible decline, as shall be seen below.

Does the Paradigm of Imperial Decline Apply to the United States?

Over the past six years or so, reference to Kennedy's paradigm was again quite tempting, with wars in Afghanistan and Iraq, growing national deficits and debt, a close call with full-scale economic calamity domestically and globally, and, until the last days of March 2010, dim prospects for a health care bill that was singularly important for this president... a maelstrom indeed.

There is reference in the vernacular of American college and professional football to sudden change resulting from a turnover, by interception or fumble, forcing an immediate redirection according to an immediate negative or positive change in circumstances. President Barack Obama suddenly finds himself with a Nobel Peace Prize in his back pocket, domestic success in national health care legislation, some

³² Piers Brendon, "Like Rome Before the Fall? Not Yet," *The New York Times*, February 25, 2010, 27 (A).

³³ *Ibid.*

modestly good news regarding economic recovery, the prospects for troop withdrawals in Iraq this year and next year in Afghanistan, and the signing of New START, the first nuclear arms reduction treaty in two decades, in Prague on April 8, 2010, and the Nuclear Security Summit in Washington, D.C. on April 12, 2010. Sudden change indeed from just a few weeks ago. All of this coincides with a recent prescription from one of the contributors to the paradigm of decline, Piers Brendon,

Despite its grave problems, there are some relatively simple steps America could take to recover its position. It could bring its military commitments into line with its resources, rely more on the ‘soft power’ of diplomacy and economic engagement and, as George Washington said, take advantage of its geographically detached situation to “defy material injury from external annoyance.” Such a policy would permit more investment in productive enterprise and pay for butter as well as guns, thus vindicating Joe Biden’s faith in the recuperative capacities of the Great Republic.³⁴

Brendon is probably correct in his conclusion just as Huntington was right about the dynamism of American power and the ability of the United States to renew its power, as is Diamond’s reference to the historical advantage of hindsight. Indeed, Joe Biden may yet prove to be quite accurate as well, but only if American leadership initiates the right policies. Hope alone may not be enough, and the time for simple renewal may actually have past. It may take something closer to reinvention.

Prospects for a New Superpower

Two questions arise at this juncture of the discussion. One, if indeed the United States on the “edge of chaos,” as Ferguson has put it, and falls as an imperial power or more to the point as a superpower, what is the likelihood that another will emerge? Is it possible that the United States is the last superpower? And two, what other states, if any, still possess the potential for superpower status?

Using Huntington’s arguments about the perseverance of American power, particularly the dynamic and adaptable nature of American power, it presents an unlikely scenario that, given a failure of the

³⁴ Ibid.

United States, some other less dynamic or adaptable state will rise to take its place as a true superpower. Hindsight regarding the Soviet Union is useful here. Given what we know now, was the U.S.S.R. a true superpower, particularly if somehow you factor out its strategic nuclear weapons?³⁵ The list of potential candidates is actually a fairly short one: the People's Republic of China, the Russian Federation, India, Brazil, a united states of Europe should the European Union ever move to that eventuality. All of these candidates are at least partially dubious in the short-run, even China. Not only do they have enormous domestic problems, they lack the kind of resources that the United States historically had at hand. The most interesting prospect would of course be a united Europe, but given the European Union's inability to make final strides towards a full economic community a political union is unlikely soon. The People's Republic of China also presents great possibilities, but until it deals successfully with a myriad of problems including a realistic currency policy, pollution, and a variety of local national issues, it is not at all clear this is the stuff of a stable superpower. The more likely conclusion would suggest the end of the superpower and the beginning of a world of rough parity, or as Richard Haas has suggested a "nonpolar world...a world dominated not by one or two or even several states but rather by dozens of actors possessing and exercising various kinds of power."³⁶ This later scenario would likely include a gradual decline in American power to a level roughly comparable with a number of other states and a world where compromise and accommodation would be increasingly necessary.

Conclusions: The Last Superpower?

What should the teacher and scholar say about the paradigm of imperial decline and potential American decline? How should we react to papers that take extreme positions predicting decline or continued preeminence? As Brendon has said, "All too often, however, students of the past succumb to the temptation to foretell the future."³⁷ This is a temptation fraught with obvious dangers, but clearly as Diamond re-

³⁵ As Tom Clancy famously put it in April 1988, "Nuclear weapons are the only legitimacy the Soviet government has to be a world power. The Soviet Union is a third-world country in every real sense—but a third-world country with 10,000 deliverable nuclear warheads. The country cannot feed itself. You cannot drive from one side of the country to another on a paved road."

³⁶ Richard Haas, "The Age of Nonpolarity: What Will Follow U.S. Dominance?" *Foreign Affairs* 87: 3 (May/June 2008): 44.

³⁷ Brendon, "Like Rome Before the Fall?"

minds readers, American leaders have the enviable advantage of historical perspective if they choose to use it.³⁸

Perhaps improbably, the dark clouds of pending disaster have parted and the United States seems to have veered away from the edge of chaos, at least for the moment. But clearly necessary changes are in the offing, including governmental cuts in programs at home and abroad, and President Obama has at least given lip service to a number of environmental issues that threaten the United States, unlike his predecessor. Michael Mandelbaum has offered that largely because of the misadventures of the George W. Bush Administration, particularly in “its profligate fiscal policies, the United States will do perhaps a good deal less abroad over the next two decades than in the last two.”

This retrenchment will not come about because the views of the Founders have gained currency among the wider U.S. public or as the result of the disappointments and failures of recent U.S. military interventions. The principal cause will be the fiscal condition of the United States. The country will bear the burden of a huge and growing national debt, from three principal sources: the chronic deficits from 2001 to 2008; the very high costs of coping with the financial crisis of 2008 and the recession it dramatically deepened; and, most importantly, the skyrocketing bill for Social Security and Medicare as the baby-boom generation becomes eligible for these entitlements.³⁹

Mandelbaum’s prognosis is sobering to be sure, but at least he has moved beyond the language of decline and fall. Clearly, the paradigm of imperial decline remains a relevant topic. The ultimate question is again whether it will be a case of imperial decline for the United States, by slow process or as a thief in the night, or renewal? History seems to have favored the process of gradual decline rather than a precipitous fall allowing time enough to take advantage of historical perspective. And in answer to that pressing question regarding the United States; for the moment the tables seem to be tipping towards renewal. It is interesting to return to Paul Kennedy who recently added a positive note regarding the importance of statecraft as *soft power* and America’s future,

³⁸ Diamond, 525.

³⁹ Michael Mandelbaum, “Overpowered? Questioning the Wisdom of American Restraint,” *Foreign Affairs* 89: 3 (May/June 2010): 118-119.

...the United States' current unpopularity worldwide is reversible—and that the best way to reverse it might be by taking a page out of the playbook of previous hyperpowers. Those empires learned an important lesson: the need for accommodation, cutting deals, cultivating allies—and keeping the steel behind the curtain, for use only in emergencies.⁴⁰

Kennedy's rather surprising optimism emphasizing accommodation and compromise seems a good point to end the discussion for the time being as far as foreign policy is concerned. And it is likely that these turns abroad may help to allow renewal at home. Even in a reduced capacity, the United States will remain something of an economic, political, and military colossus as Niall Ferguson has said, one not likely to see another contender for the title of superpower in the near future.

Professor of History Frank Bourne of Princeton University always opened and closed his course on Ancient Rome with the phrase *De nobis fabula narrator*, that is, *Their story is our story*. Indeed, there is much to be said about the American debt to Rome on many levels as well as a number of similarities. But the fatal eventualities borne of the Roman imperial paradigm may not hold true for the United States, as Piers Brendon noted earlier. Hopefully, these may yet serve as instructive warnings (apologies to Edward Gibbon and Paul Kennedy) rather than harbingers of doom. It is far too early to speculate about the fall of the United States as a great power or perhaps even its possible decline, but it is all too clear that this superpower has lost a significant amount of its power, influence, and prestige. It is also clear that much of the blame must rest with the last presidential administration and both its economic and foreign policies. But what will it take to regain this mantle of prestige and power? A simple answer would follow a significant "renewal" in three areas: politics, economy, and statecraft.

Samuel P. Huntington hinged much of his thesis for American "renewal" on what he called the "self-renewing genius of American politics," something that Fareed Zakaria has also subscribed to, and to a greater or lesser extent that may have been evidenced in November 2008. But a full realization of a resurgence of his "engines of renewal" as "competition, mobility, and immigration" may take something closer to "reinvention."

For most Americans in 2008, simple political "renewal" seemed to be not enough; they looked to what amounted to something closer to

⁴⁰ Kennedy, "The Distant Horizon," 132.

political “reinvention” and were confident that they had found it in Barack Obama. The prospects for political renewal seemed at once full of initial promise after November 2008. The United States elected a new president and rather dramatically altered the face of Congress in the shadow of the Republican domination of the previous eight years. President Obama’s promises of hope and change struck vibrant chords among a significant part of the American public. Wall Street, however, seemed unconvinced by the message and still waits for more financial/economic substance, as does one of the United States creditors and economic partners, the People’s Republic of China.⁴¹

It is in the financial/economic realm where simple “renewal” may fall short of the mark. Here something closer to “reinvention,” at least up front, may be necessary to restore stability both domestically and internationally. And to be honest neither the stock market nor so-called financial experts are convinced of the validity of the Obama recovery plan.⁴² A stimulus package, tax adjustments, an unprecedented new Federal budget, and literally a host of financial bailouts have ushered in what Obama hopes will begin a recovery process to an economic crisis that is still not over. It is not at all clear whether they will also stimulate positive competition or social and economic mobility, or whether they will restore the desirability of immigration to the United States for the sake of a better life.

The broad experience of the George W. Bush Administration as well as the particular tenor of John McCain’s 2008 campaign for the presidency cast a dim light on diplomacy and statecraft. Candidate Barack Obama was regularly criticized for suggesting possible talks with those it considered to be troublesome world leaders. President Bush had rather openly refused to “reward” some of these people with diplomacy. What was lost here was the simple fact that, one, these are exactly the people you need to talk to, and two, even limited diplomacy is preferable to war.⁴³ The good news is what appears to be an early commitment to diplomacy and statecraft by President Obama with the

⁴¹ Note the comments of Chinese Premier Wen Jiabao on March 13, 2009: “We are concerned about the safety of our assets. To be honest, I’m a little worried.” He went on to urge the United States to “...honor its word and stay a credible nation and ensure the safety of Chinese assets.”

⁴² Ironically, many of the critics could be tied to the ill-advised policies that helped bring about the economic/financial demise.

⁴³ This was exactly the point intended by President John F. Kennedy in his *Inaugural Address* (January 1961), “Let us never negotiate out of fear. But let us never fear to negotiate.” Possibly a passing sentiment in the 1961 inaugural but clearly one of the cornerstones of Kennedy’s *Commencement Address* at American University in June 1963.

appointment and initial efforts of Hillary Rodham Clinton as Secretary of State, George J. Mitchell as Special Emissary to the Middle East, and Richard Holbrooke as Special Representative to Afghanistan and Pakistan. The potential for a renewal of positive statecraft would prove critical to a general renewal of American prestige and power.

Writing about the challenges facing the United States in 2006–2007, Dennis Ross, former Middle East envoy and negotiator for both George H.W. Bush and William Jefferson Clinton, said “We can redeem our foreign policy and our place in the world. But if we are to do so, statecraft must no longer be a lost art. It is time to rediscover it.”⁴⁴ Clearly, Ross was spot on regarding the need for statecraft at a time when a president seemed loath to use it properly, and today it is still part of what must be a broad process of renewal. But the problems facing the United States in 2007 were certainly less than the full load that President Obama faced as the newly elected president in 2009 or those that continue in 2010.

This is a critical time in the history of the United States, and while it is unlikely to fall abruptly, according to Niall Ferguson’s scenario of a thief in the night, there has clearly been a significant loss of power and prestige, although again not likely to be enough to immediately strip away the title and reality of superpower status. But certainly this is a time that demands some degree of renewal, if not some reinvention. There is the famous story of Benjamin Franklin at the close of the Constitutional Convention in Philadelphia in 1787, where it is said he paused to consider whether the image of the sun painted on the back of the chair that George Washington had occupied throughout the proceedings was a rising sun or a setting sun. He finally concluded, “. . . now at length I have the happiness to know that it is a rising and not a setting sun.” Only time will tell if Franklin’s optimism will again apply to the “empire of liberty” in the 21st century.

Bibliography

Apocalypse. Mel Gibson, dir. and prod. 139 mins. Touchstone Pictures, 2006; Buena Vista, 2007, DVD.

Barnett, Thomas P.M. “Obama’s New Map.” *Esquire* 151: 3 (March 2009): 53–54.

⁴⁴ Dennis Ross, *Statecraft: And How to Restore America’s Standing in the World* (New York: Farrar Straus, and Giroux, 2007), 341.

Bobbitt, Phillip. *The Shield of Achilles: War, Peace, and the Course of History*. New York: Anchor Books, 2002.

_____. *Terror and Consent: The Wars for the Twenty-First Century*. New York: Alfred A. Knopf, 2008.

Brendon, Piers Brendon. "Like Rome Before the Fall? Not Yet." *The New York Times*, February 25, 2010, 27 (A).

_____. *The Decline and Fall of the British Empire: 1781-1997*. New York: Vintage Books, 2010.

Brzezinski, Zbigniew. "From Hope to Audacity: Appraising Obama's Foreign Policy." *Foreign Affairs* 89: 1 (January/February 2010): 16-30.

Diamond, Jared. *Collapse: How Societies Choose to Fail or Succeed*. New York: Penguin Books, 2005.

The Fall of the Roman Empire. Anthony Mann, dir. and Samuel Bronston, prod. 185 mins. Samuel Bronston, 1964; The Miriam Collection, 2008, DVD.

Ferguson, Niall. *Colossus: The Price of America's Empire*. New York: The Penguin Press, 2004.

_____. "Complexity and Collapse: Empires on the Edge of Chaos." *Foreign Affairs* 89: 2 (March/April 2010): 18-32.

_____. *Empire: The Rise and Demise of the British World Order and the Lessons For Global Power*. New York: Basic Books, 2002.

_____. "Hegemony or Empire?" *Foreign Affairs* 82: 5 (September/October 2003): 154-161.

_____. "Wall Street Lays Another Egg." *Vanity Fair* No. 580 (December 2008): 190-205.

French, Howard W. "Thinking Globally; America's Rise to Dominance, With Slips Along the Way." *The New York Times*, November 24, 2008, 7 (C).

Fromkin, David. *In the Time of the Americans: FDR, Truman, Eisenhower, Marshall, MacArthur—The Generation That Changed*

America's Role in the World. New York: Alfred A. Knopf, 1995.

Gibbon, Edward. *The Decline and Fall of the Roman Empire*. London: W. Strahan and T. Cadell, 1776-1788; New York: Washington Square Press, 1963.

Haas, Richard N. "The Age of Nonpolarity: What Will Follow U.S. Dominance?" *Foreign Affairs* 87: 3 (May/June 2008): 44-56.

Herring, George C. *From Colony to Superpower: U.S. Foreign Relations Since 1776*. Oxford: Oxford University Press, 2008.

Holbrooke, Richard. "The Next President: Mastering a Daunting Agenda." *Foreign Affairs* 87: 5 (September/October 2008): 2-24.

Huntington, Samuel P. "The U.S.-Decline or Renewal?" *Foreign Affairs* 67: 2 (Winter 1988-1989): 76-96.

_____. "The Lonely Superpower." *Foreign Affairs* 78: 2 (March/April 1999): 35-49.

_____. "The Clash of Civilizations." *Foreign Affairs* 72: 3 (Summer 1993): 22-49.

_____. "If Not Civilizations, What? Paradigms of the Post-Cold War World." *Foreign Affairs* 72: 5 (November/December 1993): 186-194.

Kagan, Robert. *Of Paradise and Power: America and Europe in the New World Order*. New York: Alfred A. Knopf, 2003.

Kennedy, Paul. *The Rise and Fall of the Great Powers: Economic Change and Military Conflict from 1500 to 2000*. New York: Random House, 1987.

_____. "The Distant Horizon: What Can 'Big History' Tell Us About America's Future?" *Foreign Affairs* 87: 3 (May/June 2008): 126-132.

Ibn Khaldun. *The Muqaddimah: An Introduction to History*. Franz Rosenthal, trans. Princeton: Princeton University Press, 1989.

Kissinger, Henry. *Diplomacy*. New York and London: Simon and Schuster, 1994.

_____. *Does America Need a Foreign Policy?* New York and London: Simon and Schuster, 2001.

Linderski, Jerzy. "Si Vis Pacem, Para Bellum: Concepts of Defensive Imperialism." From *The Imperialism of Mid-Republican Rome*. Papers and Monographs Volume 29. Rome: American Academy in Rome, 1984, 133-164.

Mandelbaum, Michael. "Overpowered? Questioning the Wisdom of American Restraint." *Foreign Affairs* 89: 3 (May/June 2010): 114-119.

Meyer, Karl E., and Shareen Blair Brysac. *Kingmakers: The Invention of the Modern Middle East*. New York and London: W.W. Norton & Company, 2008

Morgenthau, Hans J. *Politics Among Nations: The Struggle for Power and Peace*. 5th ed. Revised. New York: Alfred A. Knopf, 1978.

Niebuhr, Reinhold. *The Irony of American History*. Chicago: University of Chicago Press, 2008.

Polybius. *The Rise of the Roman Empire*. Ian Scott-Kilvert, trans. London and New York: Penguin Books, 1979.

Rashid, Ahmed. *Descent Into Chaos: The U.S. and the Disasters in Pakistan, Afghanistan, and Central Asia*. New York: Penguin Books, 2009

Rice, Condoleezza. "Promoting the National Interest." *Foreign Affairs* 79: 1 (January/February 2000): 45-62.

_____. "Rethinking the National Interest: American Realism for a New World." *Foreign Affairs* 87: 4 (July/August 2008): 2-26.

Ricks, Thomas E. *The Gamble: General David Petraeus and the American Military Adventure in Iraq*. New York: Penguin Press, 2009.

Ross, Dennis. *Statecraft and How to Restore America's Standing in the World*. Farrar, Strauss and Giroux, 2007.

Schlesinger, Arthur M., Jr. *War and the American Presidency*. New York and London: W.W. Norton & Company, 2004.

Stathis, G. Michael. "Thucydides: Still Relevant in Post-Cold War International Relations." *Journal of the Utah Academy of Sciences, Arts, and Letters* 75 (1998): 192-206.

_____. "Statesmanship and Politics: A Realist Interpretation With Perspectives on American Statecraft." *Journal of the Utah Academy of Sciences, Arts, and Letters* 82 (2005): 228-249.

Stoessinger, J.G. *Crusaders and Pragmatists: Movers of American Foreign Policy*. 2nd ed. New York and London: W.W. Norton and Company, 1985.

_____. *Why Nations Go To War*, 9th ed. Belmont: Thomson/Wadsworth, 2005.

Thucydides. *The Peloponnesian War*. Walter Blanco trans. Walter Blanco and Jennifer Tolbert Roberts, eds. New York and London: W.W. Norton & Company, 1998.

Tucker, Robert W., and David C. Hendrickson. *Empire of Liberty: The Statecraft of Thomas Jefferson*. Oxford and New York: Oxford University Press, 1990.

Urquhart, Brian. "What You Can Learn from Reinhold Niebuhr." *The New York Review of Books* 56: 5 (March 26, 2009): 22-24.

Woodward, Bob. *State of Denial: Bush at War, Part III*. New York and London: Simon & Schuster, 2006.

Zakaria, Fareed. "The Future of American Power: How America Can Survive the Rise of the Rest." *Foreign Affairs* 87: 3 (May/June 2008): 18-45.

_____. *The Post-American World*. New York: W.W. Norton and Co., 2009.

The Economics of Geographical Ward Boundaries in the LDS Church

Daniel Robertson and Tyler Bowles
Utah State University

Abstract

Just a few years ago, Michael McBride published his intriguing article “Club Mormon: Free-Riders, Monitoring, and Exclusion in the LDS Church,” highlighting important incentives at work in the organization of the Church. In his discussion of the Church’s efforts to monitor its members, McBride mentions, almost in passing, that the Church uses geographical ward boundaries to maintain ward sizes small since smaller congregations require fewer monitoring costs. In this paper, we argue that the Church uses geographical boundaries not only to control ward size, but also to stimulate the creation of religious capital. Ward boundaries do this by stabilizing the ratio of high-contributing to low-contributing members in a ward. This results in each ward collectively having a type of “property right” over those within their boundaries. These aspects of ward boundaries increase the efficiency of religious capital production. We hypothesize that the benefits of thus restricting members’ choice of ward outweigh the associated costs.

Introduction

One interesting characteristic of the modern Church of Jesus Christ of Latter-Day Saints (LDS) is that it continues to use geographic boundaries to organize its members into basic ecclesiastical units called wards, which are often compared with Catholic parishes. This means that in the LDS Church today, individual members' addresses determine not only when and where they will attend services, but also those with whom they will be worshipping. In other words, place is fate for current members of the LDS Church. Place used to be fate for members of the Catholic Church as well, but since the Second Vatican Council in the early 1960s, the Catholic Church has moved away from geographical parish boundaries in an attempt to focus less on geography and more on community. The comparison of wards with parishes, therefore, while meant to facilitate an understanding of the organizational structure of the LDS Church for those unfamiliar with it, also highlights disparities between them and motivates the desire to know why they are different.

Some authors have already considered the effects of the policy changes concerning parish boundaries within the Catholic Church. Moving away from such boundaries, for example, can be seen as the introduction of competition into the Catholic Church (de Groot 2007; Hadaway 2009; McBrien 1995). These authors reason that the freedom for Catholics to choose their own parish gives priests the incentive to prepare better services and to take better care of the members of their parish in general; if they do not, their parish members will move to other parishes. There is some evidence that Catholics have been taking advantage of the religious marketplace to best accommodate their needs (Maines and McCallion 2004; Office of Pastoral Resources and Research, Archdiocese of Detroit 2005).¹ A second argument in support of the actions of the Catholic Church is that letting individuals choose their parish will increase lay involvement in general—one of the objectives endorsed by the Second Vatican Council (Maines and McCallion 2004; p. 98). This argument is based upon the *de facto* congregationalism hypothesis, which posits that the decisions that govern congregations are increasingly being made on the local level in the United States. This local control gives congregations the flexibility they need to cater to their members' needs, which may help explain why religious

¹ This line of argument goes all the way back to Adam Smith in the fifth chapter of *The Wealth of Nations*.

participation rates in the U. S. are relatively high (Warner 1993) and which therefore sheds some light on the reasons behind the policy changes of the Second Vatican Council. These two arguments, while by no means a complete summary of the work done on the Catholic Church, adequately portray the importance of the incentives that institutional structures create and the impact they have on their members. Those who have considered the impact of the incentives created by the Second Vatican Council in separating place from fate seem to agree that such incentives are, if not positive, at least necessary for the continuation of the Catholic Church in contemporary western culture.

We must then ask why the LDS Church continues to organize its wards geographically. It is not at first clear to what extent the competition argument can be used for the LDS Church. The Church uses an uncompensated, lay clergy, so having more members does not translate into more money for the clergy. In addition, the budget for each congregation is mandated by the central headquarters in Salt Lake City, so having more members does not necessarily mean more money from Salt Lake City. More members may mean more money for the ward though, since the entire LDS Church holds a fast on the first Sunday of each month and each ward collects "fast offerings" from its members. Members are encouraged to donate an amount at least as great as their meals would have cost had they not fasted, and these donations remain in the ward and are distributed to the poor. It might seem, then, that ward leaders would want to recruit members with larger incomes into their wards to increase fast-offering levels, giving leaders more discretion to help their poor. There is a limit, however, to any incentive this may give wards to compete against each other. The LDS Church maintains its wards at a standard, relatively small size. If a ward becomes too large, it will eventually be split into two new wards. Such a split would quash all earlier attempts of the original local leaders to recruit new ward members, and they would have to start over again. There does not seem to be, therefore, any compelling reason why one ward would compete against another for members within the church.

The argument concerning increased lay involvement, however, is not easily dismissed or evaded. The LDS Church depends heavily on its lay clergy, particularly at the local level. Almost every member has a role to play in the operations of the local ward. If letting members choose their own ward tends to increase lay involvement, why would the Church deny its members this freedom? It is this question we wish to address. We do so by building on Michael McBride's "menu-monitoring model," arguing that the Church uses geographical ward boundaries to make religious capital creation more efficient. Ward boundaries do this in part by stabilizing the ratio of high- to low-

contributing members in each ward. They simultaneously give the ward a type of “property right” over those living in their jurisdiction. In short, the ward is given a relatively stable set of resources, and it therefore has the incentive to develop these resources for its own benefit. We suggest that since the Church has continued to use geographical ward boundaries, the efficiencies in religious capital creation gained from the use of ward boundaries must offset the costs incurred from any decrease in lay involvement associated with denying members the choice of ward.

Literature Review

In order to understand McBride (2007), it is useful to begin with Iannaccone (1992). Iannaccone develops a joint production model where “a person’s religious satisfaction depends on both his or her own inputs and those of others” (p. 274). The inputs of goods and time that one person devotes to his or her own religious participation benefit other members of the church by increasing the quality of the church. In this way, religious participation creates a positive externality for others, and, as a consequence, members will not choose to participate as much as is desirable from a club-wide perspective. That is, religious participation exhibits “positive crowding.” Therefore, members have the incentive to “free-ride” on the participation of other members, even when all the members are identical and equally value religious participation.

Because of the unique nature of religion, however, the familiar solutions to positive externalities (e.g., subsidies) do not seem to be appropriate. Not only does paying people to participate seem disingenuous, but Iannaccone notes that “such schemes are rarely practical” (p. 274). Iannaccone concludes that there is “a kind of ‘second-best’ solution” where “[i]nstead of subsidizing participation, churches can prohibit or penalize alternative activities that compete for members’ resources” (p. 275). By placing stigmas on and prohibiting particular secular activities, the church would in effect be raising the price of those activities for church members, and the members would therefore substitute away from the prohibited activities toward religious activities. Iannaccone is able to show that the church should target those secular activities for which there is a sufficiently high degree of substitutability.

While the free-rider problem among homogenous populations is remedied by ongoing prohibitions, Iannaccone explains that only member heterogeneity can “account for one-time costs” (p. 281). The free-rider problem resurfaces among populations in which not all members are identical since “people with low levels of participation have an in-

centive to free-ride off groups with high average levels of participation” (p. 281). Iannaccone concludes that the church is able to discourage such behavior by exacting “one-time costs” from its members. These one-time costs, or sacrifices, screen out potential members with low levels of commitment. Those individuals who ultimately choose to make the sacrifice and join the church are therefore more likely to have high levels of participation. Using a game-theoretic framework, Iannaccone is able to prove that in a church composed of two types of people, as long as one type always participates less and values participation less than the other and is sufficiently large, there will be a signaling equilibrium where those who value participation more will “end up in groups that require their members to sacrifice a valued resource or opportunity” while those who value participation less will “end up in groups that require no such sacrifice” (p. 283). He calls this result Proposition 2 and uses it to explain the reason for the existence of less-demanding “churches” and more rigid “sects.”

In response, McBride (2007) argues that “[a] group would ... only resort to [Iannaccone’s model of] stigma-screening if it cannot identify and selectively reward those who contribute to the group” (p. 398). This is not a startling argument—Iannaccone himself justified his model by emphasizing how it is notoriously difficult within a religious context to identify and reward high-contributors. McBride’s contribution, though, is in detailing how a church (in this case, the LDS Church) might be able to do just that. “Instead of offering one club good,” he says, “the Mormon Church is better understood as implicitly providing a menu of club goods such that the more a member contributes, the more excludable benefits that person receives.” That is, by excluding low-contributors from certain goods, the church gives individual members of the church an incentive to contribute more and free-ride less. Implementing such exclusion may be costly, however, depending on the time and resources required to implement it; therefore a more realistic policy would be that low-contributing members should be excluded from goods that can be excluded at low cost. The effectiveness of the incentives created by this exclusion ultimately depends upon the Church’s ability to make good on its intentions to exclude low-contributors from certain goods. McBride therefore places great emphasis on the “Church’s sophisticated administrative structure [which] is used to monitor members and enforce the terms of the menu” (p. 397). This emphasis can be seen in McBride’s characterization of his paradigm as a “menu-monitoring” model (as opposed to Iannaccone’s “stigma-screening” model).

Geographical Ward Boundaries

In his discussion of the monitoring programs in the Church, McBride acknowledges that there are “higher-order collective action problems that the [Church] must resolve to ensure that the monitors do their jobs” (p. 411). Effective monitoring benefits all members in McBride’s analysis, but the cost of monitoring—the time and the energy required—are born by individual members. This dispersion of benefits and concentration of costs leads to another free-rider problem where there will be too little monitoring. It is here where McBride first mentions, almost in passing, the use of geographical ward boundaries in the Church:

The Church’s policy concerning ward sizes also helps [to mitigate the higher-order collective action problem]. Wards, which are defined according to geographical boundaries, are split once their memberships become large. Keeping wards small fosters repeated interaction through various Church-related activities and improves monitoring. (p. 412)

McBride’s insight here appears to be sound. Smaller groups, as first noted by Mancur Olson (1971), are less susceptible to free-riding since members are more likely to know each other and to be aware of each others’ actions. Geographical boundaries are an easy way of organizing members into small wards and managing membership levels. But size is only one aspect of the ward affected by such boundaries. The composition of the ward is another. Boundaries determine not only how many members are in a ward but also which types of members are in which wards. To see what implications the composition of wards will have on Church vitality, we must first return to another important result of the menu-monitoring model.

McBride emphasizes that a natural consequence of the menu-monitoring approach is that “any variation in conviction, religious capital, outside economic opportunities, etc. among members...will result in observable variation in religiosity within the LDS Church” (pp. 414, 415). In the following paragraph, McBride posits that by tolerating the presence of low-contributors alongside of high-contributors, the church is actually facilitating interactions between the two types of members—interactions that can help the low-contributing members accumulate the religious capital they need to become high-contributing members. Indeed, one of McBride’s most perceptive insights is that there are some goods the church provides that are excludable at low cost *but that are not excluded from anyone*. The high-contributing members generating

the goods are therefore more likely to be brought into contact with the low-contributing members consuming the goods, increasing the likelihood of religious capital creation among low-contributing members. Using such logic, McBride concludes that “while the Church does not encourage free-riding *per se*, it openly allows low-commitment members to free-ride to a limited extent...in the hope that they will become high contributors” (p. 415). Two of the explicitly stated goals of the Church—to grow its membership and to increase the contributions of current members—can be reinterpreted as religious capital creation. McBride therefore sees the menu-monitoring approach, which gives individuals incentive to contribute more and which allows enough diversity for high-contributors to generate new religious capital in low-contributors, as a way for the Church to attain its goals (p. 397).

It is not clear, then, what McBride means when he says that his logic “does not imply that the Church prefers variation in religiosity to every member being highly committed” (p. 415). The Church of course would say that it would like all of its members to be high-contributors. But the Church also maintains an extensive missionary program to bring more members into the Church, and few of those new members will begin as high-contributors. So there is an apparent tension in the desires of the Church: Would the Church really prefer having many members or only high-contributing members? To shed light on this question, it is perhaps instructive to look more carefully at the nature of the creation of religious capital. Consider, for example, the long-term experience of a member of a religious organization. New converts to churches are barraged with new rites and ordinances, doctrines,¹ and customs, not to mention new acquaintances and friends. After a year or two, though, if they have truly found a faith that suits them, most will have comfortably assimilated to their new faiths. How much more religious capital, then, will they require? In other words, it seems that the creation of religious capital, as with many other forms of production, experiences diminishing returns. If, indeed, it is the case that it is easier to create religious capital in new and less-involved members, then the Church should prefer to maintain some variation in religiosity in its congregations to create more religious capital more efficiently. Therefore, it would be reasonable that there would be an optimal level of diversity in a ward, some optimal ratio of high- to low-contributing members.²

² In a working paper, Katherine Anderson uses both game and network theory to conclude that unrestrained homogeneous individuals will tend to form groups that are too large and that membership restrictions should be used to achieve optimal group size. She also mentions that “requiring a social or spatial connection can effectively substitute” for

If this is so, there would be two rationales to the splitting of wards that McBride mentions. One, of course, is to keep the size of the ward small, as McBride observed. But since the Church organizes all of its wards in the same way, each with the same leadership positions and titles, it also seems that a larger ward is more likely to have a surplus of high-contributing members. That is, wards with relatively large ratios of high- to low-contributing members may not use their available religious capital efficiently since some of that capital may be unemployed. We can even say more than this if we assume diminishing marginal returns. Then wards with larger than optimal ratios of high- to low-contributing members (larger wards) *cannot* use their available religious capital as efficiently as wards with optimal such ratios, even if they succeed in employing all available religious capital. So a second, more subtle, rationale for splitting the ward is to lower the ratio of high- to low-contributing members closer to its optimal level.

From there it is only a short step to argue that the Church will draw the ward boundaries in ways that optimize the diversity in each ward when it is able to do so.³ It is obvious that the Church cannot choose exactly which members will attend which wards, since households are free to move whenever they wish. Stories of “ward shopping” are not unheard of, if not common, but the Church does have some limited control over which *types* of members attend certain wards since it can choose which neighborhoods to include in a ward. The Church, for example, may include high-income neighborhoods with low-income neighborhoods, or older neighborhoods with younger neighborhoods, or neighborhoods having more single-family homes with neighborhoods having more apartments. Anecdotal evidence suggests that ward boundaries are indeed drawn with these intentions.⁴ A certain stake in Provo, Utah, for example, has a number of wards that are only a few streets wide but approximately 15 streets long (Figure 1). Specifically, consider wards five through nine (ward nine does not

membership restrictions (p. 20). This justifies McBride’s view of ward boundaries limiting ward size. In this paper, we suggest that the LDS Church uses spatial connections in an attempt to optimize the composition of coalitions given the heterogeneity of its members.

³ To make strategic decisions in drawing boundaries, the Church would of course require the ability to draw the boundaries in many ways. This presupposes that in the area under consideration the Church is well established and that there are indeed enough members living in diverse neighborhoods to give Church leaders some latitude in choosing boundaries.

⁴ A more methodical study of LDS ward boundaries is required to make any definitive conclusions; we are aware of no such study.

appear as narrow as the others but much of the northern area in the ward is nonresidential).

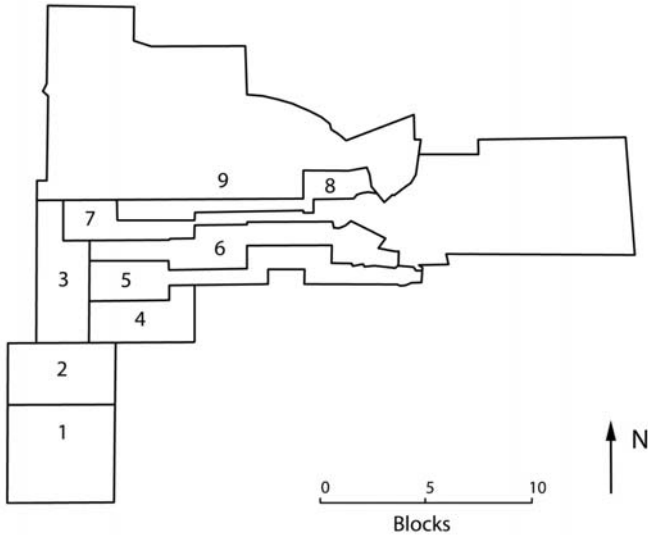

Figure 1: Ward boundaries of a Provo Stake

These wards are drawn this way since there are many young married couples who study at Brigham Young University (BYU) and who live in the stake. By making the wards long and narrow, Church leaders included neighborhoods with both long- and short-term residents in each ward, allowing the less well-established and somewhat busier (low-contributing) students to benefit from the stability and efforts of the more established (high-contributing) members.

This provides some evidence for the idea that the Church can create closer-to-optimal diversity by including different neighborhoods in one ward. Figure 2 corroborates this by showing that the western halves of wards five through nine lie in a different neighborhood than their eastern halves.

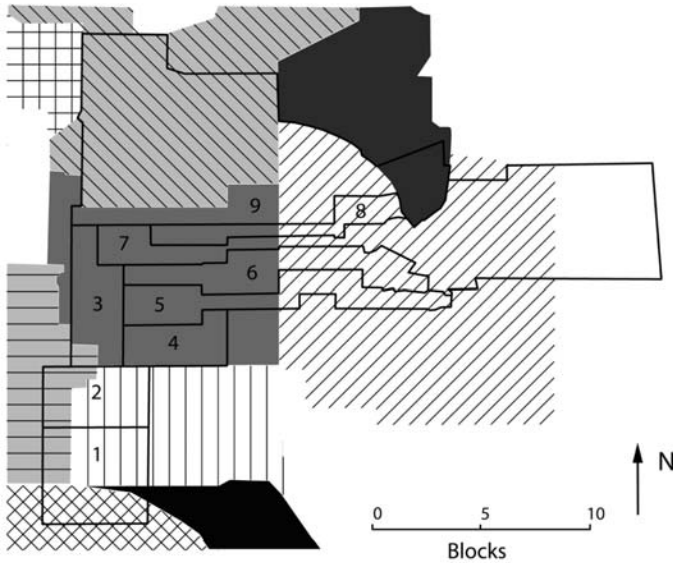

Figure 2: Ward boundaries with official Provo neighborhoods overlaid

This central-west neighborhood containing wards three through nine is closer to BYU and therefore has a large student/renter population. The neighborhood directly to the east has relatively fewer apartments and more houses and therefore a relatively larger non-student/long-term resident population. The easternmost part of ward nine is a case in point: The portion of the dark-shaded neighborhood it snags could just as easily have been included in another stake. The area is circumscribed with roads, so one cannot argue that its inclusion in the stake and in ward nine is due to a natural division. When compared with wards five through eight, though, it is no surprise that it would be included in ward nine since that just continues the pattern of long, narrow wards.⁵

⁵ Wards one through four, of course, do not follow this long-but-narrow pattern. Although we have not yet examined these wards individually, we can conjecture that they have fewer newly married student couples. We can also conjecture that if they needed more diversity, their boundaries would be drawn in more peculiar ways. The presence of wards shaped so differently in a single stake only provides further evidence of our hypothesis.

Other variables the Church seems to consider when drawing boundaries are the boundaries of both school districts and civic districts. As implied above, interactions with other members are one of the key factors in the creation of religious capital, but there is no need for the Church to limit the interactions it takes into consideration to interactions at church-sponsored activities. Constructive interactions between members in forums outside of Church will only strengthen their existing religious capital. The Church will therefore tend to draw ward boundaries in ways that maximize the interaction of its members in both secular and religious contexts. By drawing ward boundaries to coincide with school boundaries, for example, the Church assures that the children who go to church together also go to school together. The children in the Church will therefore have a good chance of creating a stable Church-oriented network of friends, which will encourage higher levels of religious capital among them. The Provo stake we considered above does not cut across high school or middle school boundaries. Since those boundaries are so large, one would need to consider a collection of stakes to see how stake and ward boundaries interact with them, but the stake does lie within the boundaries of two different elementary schools (Figure 3).

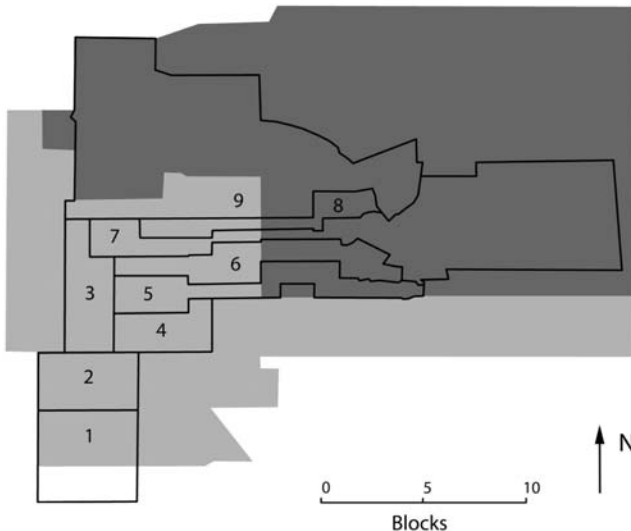

Figure 3: Ward boundaries with elementary school boundaries overlaid

It does not seem that the Church took these elementary school boundaries into consideration when drawing ward boundaries, since

wards five through nine all cut across school boundaries. Perhaps Church leaders, knowing that the western halves of those wards had a large college student population and would therefore have fewer children on average, did not find it necessary to consider elementary school boundaries when drawing ward boundaries; achieving an optimal high-to-low-contributor ratio was a higher priority. This would be consistent with our hypothesis of strategic ward boundary drawing.

Another way to interpret the peculiar boundaries of wards five through nine is that they increase the stability of the ward and the stability of its religious capital. Some elements of religious capital appear to be transferable and others nontransferable: knowledge of church doctrine, principles, and policies, for example, will not diminish when a member moves from one ward to another. The mutual trust that develops between members in a specific ward and the corresponding ability to work well together, however, will certainly not follow the member who moves to another ward where he or she knows no other members. The time that it takes for such trust to develop is a cost the Church must bear each time a member moves. It is therefore in the interest of the Church to discourage frequent moving. Common economic logic suggests that members of the Church would likely transfer their membership records from one ward to another more often if they could do so without cost. The Church is acting in its best interest, then, by making place fate for ward membership, since this implicitly raises the cost of transferring records from one ward to another to at least the amount it would cost to move one's place of residence to the new ward. Since it is therefore costly to transfer membership from one ward to another, members will tend to remain in wards for longer periods of time on average. This will give members more opportunities to interact with each other, to get to know and help each other, or to put up with each other as the case may be, all of which will tend to increase members' levels of religious capital. Without the opportunity for prolonged interaction with other members, it is less likely that a member will develop enough religious capital to become a high-contributing member.

This idea of stability hints at another benefit derived from geographical boundaries: Such boundaries create an incentive for high-contributing members to help low-contributing members develop religious capital. In an article focusing on the proselytary efforts of the LDS Church, Rick Phillips (2008) discusses certain tensions between the centrally organized full-time missionaries and the more locally oriented ward members. He focuses on how the goal of the full-time missionaries is to maximize total membership, while the "ward's highest priority is sustaining a vibrant religious community that meets the needs of its diverse membership" (p. 632). Since "[n]ew converts drain

ward resources,” he says, “the ward seeks committed converts who can quickly demonstrate *that investing in them will pay dividends*” (pp. 632, 633, emphasis added). In the context of this paper, we could substitute “low-contributing members with high-contributing potential” for “committed converts” in this quote. What is interesting about the italicized statement is the implicit assumption it makes that high-contributing members will benefit from the future contributions of their investments in low-contributing members’ religious capital. Suppose, for example, that some high-contributing members of a certain ward spent time helping a low-contributing member in the ward to develop religious capital. If that low-contributing member, having attained a sufficient amount of religious capital to become a high-contributor, could choose on a whim to attend whichever ward s/he wanted, then the high-contributing members that initially invested in them would not be likely to obtain the “dividends” from their “investment.” They would have no (economic) incentive to invest in that person. The assumption Phillips makes is that geographical boundaries give the ward, for lack of a better term, a “property right” over those residing in their jurisdiction.⁶ The ward is given a more or less stable set of resources and its objective is to utilize and develop those resources to create a vibrant community. The idea of a property right is not quite right here, though, since members can move at will from the ward, so perhaps a better way to put it is that geographical boundaries increase the probability that high-contributing members will benefit from their investments in low-contributing members, which increases the high-contributing members’ expected net benefit of investing and leads them to invest more than they would without the boundaries. The use of geographical boundaries, in this way, gives high-contributing members greater incentive to invest in low-contributing members.⁷

Those skeptical of this argument might respond that members would be more likely to help people develop religious capital if they could choose who those people would be. Would not geographical boundaries limit such so-called investments? What incentive does a member then have to invest time in someone living outside his or her

⁶ Those members who attend the temple covenant to consecrate their time, talents and means to the Lord, so in a sense they may be seen as assets of the church.

⁷ It is important to note that this incentive is only effective as long as the size of the ward is small. Once the ward becomes large, then members will suspect that the ward will be split and therefore the expected net benefit of any investment in current low-contributing members in the ward will fall dramatically. Perhaps this is one rationale to maintain a centrally organized missionary program that will continually initiate new growth, despite the tensions that will inevitably exist between such a program and local congregations.

ward boundaries? These are formidable arguments and certainly seem to call into question the prudence of the Church's use of geographical boundaries, but in this context it is also important to remember the results of Iannaccone's analysis. Recall that in Iannaccone's Proposition 2, he concluded that in the presence of heterogeneity (high-contributors and low-contributors commingled together) then there will ultimately be a schism where low-contributors would form one group and high-contributors another requiring a sacrifice to enter.⁸ McBride's menu-monitoring method certainly appears to change the rules of Iannaccone's game in that it allows for more heterogeneity within the church on a church-wide level, thereby helping to avoid the types of schisms Iannaccone predicts for heterogeneous organizations. But there is nothing in the menu-monitoring approach to prevent members from self-partitioning into high-contributing wards and low-contributing wards. The Church would clearly not allow high-contributing wards to require a sacrifice for entry as Iannaccone predicts they would, but one can imagine all types of informal social norms that would develop to discourage entry of low-contributing members. Such partitioning would decrease the diversity within each ward and would therefore hinder the creation of new religious capital, despite the apparent benefits of self-partitioning considered at the beginning of the paragraph. By allowing diverse neighborhoods to be assigned to a single ward, geographical boundaries can help to maintain a certain level of intra-ward diversity. The high-contributing members then have an incentive to invest in the low-contributors. And the result is greater religious capital creation within the Church.

It is important to point out that this hypothesis requires that members actually do attend the ward in which they live. There is no mechanism in the Church to prevent members from *unofficially* participating in wards other than their own. But it is quite difficult for any member of the Church to become an *official* member of a ward in which he or she does not live. To do so would require not only the consent of the bishops of the wards involved, but also that of the stake president and even the First Presidency of the Church. It is also Church policy that such exceptions should be few. Trying to obtain an official exemption from church leaders with low probability of success may therefore be more hassle than it is worth. This means that for most members, official interactions with the Church must be conducted through the leaders

⁸ Isaacs and Laband (1999) found empirical evidence that greater heterogeneity in a given population is correlated with a greater number of congregations.

of the ward in which they live.⁹ A member cannot, for example, perform in any official capacity in a ward other than their own, and to obtain a temple recommend,¹⁰ the member must be interviewed by the bishop of the ward that has his or her membership records. Part of that interview concerns the member's attendance at (official) weekly services and other meetings, so a member who had been attending another ward but not his or her own would be quite unlikely to walk out of such an interview with a temple recommend. This illustrates the incentive members have to attend the wards in which they live: It just makes Church life much easier.¹¹ With such incentive, there appears to be a high degree of compliance with the organizational protocol of geographical boundaries among members of the Church.¹²

While the rules stated above certainly give members incentive to attend their official wards, such rules also lead the general membership to feel that members should "lift where they stand," or attend services in the ward in which they live. As the literature of the new institutional economics instructs, institutions are made up of not only rules but also of norms. It is so in the Church as well. If one asked a member of the Church why they attend the ward in which they live, they would likely answer that they did so simply because "that is the way it is done" or because "that is what they should do," and not because they are taking all of the costs of moving membership records or of unofficially attend-

⁹ The Catholic Church, for comparison, used quite restrictive geographical boundaries to determine parish memberships before the Second Vatican Council in the 1960s. Gerald Gamm (2001) relates a story in which a Catholic woman was temporarily moving out of one parish but wanted her membership to remain at that parish since she and her family planned on moving back before long. She quickly received the reply: "Although you and your family are free to attend whatever Church is more convenient to you, except for the sacraments of record, I regret that it is impossible to transfer you from one parish to another as long as your home remains in the territory of the former parish. Canon Law determines that individuals are members of the parish in whose territory their home is located and excludes the possibility of any Bishop making an exception to this law" (p. 44).

¹⁰ A temple recommend is an official document printed by the Church about the size of a driver's license. To be allowed to enter the temple, upon which salvation depends, a member must furnish a recommend that has been signed by local priesthood authorities, verifying that they have interviewed the member and deemed him or her worthy to enter the temple. Recommends even have barcodes now for ease of verification at the temple entrance.

¹¹ It seems to be fairly common for young single adults to officially join wards in which they do not live. To explain this, it might be argued that in the case of young single adult wards the Church is more concerned with social than religious capital.

¹² The degree of such compliance is of course subject to more empirical work, which to our knowledge has not yet been conducted.

ing wards other than their own into account. The existence of this norm makes it easy for the Church to continue using geographical ward boundaries. Without the rule, however, there would be little to maintain the strength of this norm among the membership.

Whatever the reason, the degree of compliance is what is important for our hypothesis. As long as the degree of compliance is high, the Church will have a certain amount of control over the composition of its wards and will draw the ward boundaries in a way that maximizes the Church's interests. If the level of compliance is high enough and if the Church draws ward boundaries carefully, the gains from more efficient religious capital creation induced by the boundaries may be enough to offset the decline in lay involvement and the diminished competition that such boundaries are likely to cause. Since the Church has seen fit to continue the practice of fixing geographical ward boundaries, it appears that the Church feels that the benefits of these boundaries outweigh the costs. The seemingly high level of compliance with ward boundaries among members of the Church lends credence to this perception and leads us to tentatively suggest that the benefits stemming from fixed ward boundaries do outweigh their resulting costs.

Insight from the History of Ward Boundaries

It is interesting to note that the early Church did not divide its congregations up into "wards." Nor did it use geographical boundaries. In the Nauvoo period, which began eight years after the Church was officially constituted, worship services "were generally Nauvoo-wide meetings" (Hartley 1992, p. 62). The term "ward" did not begin to show up until this Nauvoo period—the original term for the basic ecclesiastical unit of the Church, "stake," was taken from the book of Isaiah—and even then it was in a political context: "[w]ards in Nauvoo were civil divisions for police, tax, election, school, and other municipal purposes." This should come as no surprise since "[i]n the eastern United States then and now, a ward is a political subdivision of a city." Early Church leaders used these divisions "for convenience" when they "needed to collect funds to aid the poor" (p. 58). The Church designated a "bishop" for each ward to coordinate these charitable (and mainly secular) activities. Over time as the Church and its stakes grew, the smaller ward units came to be seen as subdivisions of stakes, and the bishops came to preside over their wards with both spiritual and secular functions. It seems appropriate because of the historical connection between political and religious districts to draw an analogy between strategically forming religious districts and strategically form-

ing political districts. Or rather, we can draw an analogy between the strategic drawing of ward boundaries and political gerrymandering. The analogy is of course quite limited; LDS Church members do not vote for church clergy since there are not any elections in the Church. But the Church, like political parties, does draw its boundaries in ways that maximize its interests. It may be useful therefore to call the actions of the Church described in this paper “sectarymandering.” And since McBride holds no monopoly over mnemonic model monikers, the slightly extended version of McBride’s model presented in this paper may then be dubbed the “menu-monitor-mandering” model.

Conclusion

The success of the growing field of the economics of religion in the last decades of applying rational choice theory to the study of religion suggests that it is possible to analyze churches as firms that provide religious goods and services to their members. This also suggests that religious organizations, like other secular organizations, will structure themselves in ways that advance their own self-interest. If this is true, then it is profitable to analyze their organizational structure in an attempt to understand the incentives they create and the problems they try to solve. In the case of the LDS Church, we can therefore see the use of geographical ward boundaries as a way to combat inefficiencies in the production of religious capital. Fixed ward boundaries stabilize ward membership roles by making it costly to transfer memberships. They increase the amount of interaction among members not only at church services but also in secular activities by taking school and civic boundaries into consideration. They not only keep ward sizes and therefore monitoring costs small, but they also encourage wards to make the most efficient use of their high-contributing members. They give each ward the incentive to develop the religious capital of the low-contributors within its boundaries to lighten the load of the high-contributors and to create a more vibrant religious community. As long as the assumption of diminishing returns to inputs invested in religious capital holds, ward boundaries make religious capital creation more efficient by helping to maintain closer-to-optimal high- to low-contributor ratios, forcing high-contributors to interact with low-contributors for whom religious capital is more easily created. Taking these efficiencies and incentives into account, it is indeed possible that the benefits of “sectarymandering” outweigh the costs of coercing members to attend specific wards.

References

Anderson, K. 2011. Optimal institutional design in sequential coalition formation games with a network constraint (Working paper). Retrieved March 6, 2011, from http://www.andrew.cmu.edu/user/andersok/Katharine_A._Anderson/CV_files/TeamAssembly.pdf

de Groot, K. 2007. At your service: A congregational study in Dutch Catholicism. *International Journal of Practical Theology* 10(2), 217-237.

Gamm, G. 2001. After the urban exodus: Jews, Protestants and the erosion of Catholic exceptionalism, 1950-2000. In Andrew Walsh (Ed.), *Can Charitable Choice Work? Covering Religion's Impact on Urban Affairs and Social Services* (pp. 39-55). Hartford, Connecticut: The Leonard E. Greenberg Center for the Study of Religion in Public Life.

Hadaway, K. C. 2009. Congregationally based religion: Boon or bane for faith in the West? *Review of Religious Research* 51(2), 117-133.

Hartley, W. G. 1992. Nauvoo stake, priesthood quorums, and the Church's first wards. *BYU Studies* 32(1, 2), 57-80.

Iannaccone, L. 1992. Sacrifice and stigma: Reducing free-riding in cults, communes and other collectives. *Journal of Political Economy* 100(2), 271-291.

Isaacs, J. P., and Laband, D. N. 1999. Within-group homogeneity and exit in religious clubs. *Applied Economics Letters*, 6(12), 805-808.

Maines, D. R., and McCallion, M. J. 2004. Evidence and speculations on Catholic de facto congregationalism. *Review of Religious Research* 46(1), 92-101.

McBride, M. 2007. Club Mormon: Free-riders, monitoring and exclusion in the LDS Church. *Rationality and Society* 19(4), 395-424.

McBrien, R. 1995. Laity shops for good liturgy, good preaching. *National Catholic Reporter* 32(6), 17.

Office of Pastoral Resources and Research, Archdiocese of Detroit. 2005. Number of Catholic families living within their parish

boundaries. *Review of Religious Research* 46(3), 308–9.

Olson, M. 1971. *The Logic of Collective Action*. Cambridge, Mass.: Harvard University Press.

Phillips, R. 2008. “De Facto Congregationalism” and Mormon missionary outreach: An ethnographic case study. *Journal for the Scientific Study of Religion* 47(4), 628–643.

Warner, R. S. 1993. Work in progress toward a new paradigm for the sociological study of religion in the United States. *American Journal of Sociology* 98(5), 1044–93.

Abstracts

ARTS

World War in the Wasatch Mountains

Stephen B. Armstrong

Dixie State College of Utah

In 1967, director Andrew V. McLaglen came to Utah to shoot a World War II adventure film with actors William Holden, Vince Edwards, and Cliff Robertson. Titled “The Devil’s Brigade,” the motion picture chronicles the efforts of American and Canadian troops as they struggle to drive Nazi forces out of the Italian Alps. For the picture’s climactic sequence, McLaglen and the film’s producer, David L. Wolper, set up their cameras in and around the Wasatch Front, exploiting the area’s soaring cliffs and sweeping views. This paper traces the production history of *The Devil’s Brigade*, providing information about the filmmakers’ reasons for choosing the Wasatch region as a production location and the challenges they experienced shooting their movie in this rugged section of our state.

ARTS

InterPlay: Performing on a High Tech Wire: (Telematic Cinema)

Elizabeth Ann Miklavcic and Jimmy Miklavcic

Another Language Performing Arts Company

University of Utah Center for High Performance Computing

In this paper we will discuss our experiences in creating projects within the *InterPlay* performance form. Through the investigation of five performances, we will describe the *InterPlay* form and discuss the process and structure. We will examine some of the issues that have been encountered and surmounted and those that require continued examination. We will discuss subjects such as distributed collaboration, communications, production elements, real and virtual venues, and the layered development of works within this innovative art form.

ARTS

Musical Energy Analysis: A New Aspect of Phenomenology

Brian Mortensen

Utah Valley University

While traditional musical analysis deciphers the form of music based on predefined rules, Musical Phenomenology focuses on the way the average audience member perceives musical sound and form by considering aspects such as motion, tonal quality, and harmony. Few scholars, however, have attempted to study what affects the perception of dynamic growth. While most assume that dynamic growth and decay are simply a function of loudness, this paper will posit that the perception of dynamics is a function of the energy in the music, energy that is an interaction of the pace, pitch, loudness, and texture of the musical fabric. It will discuss the effect that each of these elements has on musical energy, propose a method to analyze changes quantitatively in musical energy over the course of a work, and test this method on Anton Bruckner's "Os justi" to determine the perceived musical form.

ARTS**Action Research in Dance: Preliminary Findings of a Study that Employed Visitor-Employed Photography (VEP) as the Basis for Choreography****Angie Banchemo-Kelleher, Amy Markgraf-Jacobson, and Betsy Lindley***Utah Valley University*

The purpose of this presentation is to inform attendees of the efficacy of using visitor-employed photography (VEP) and dance as a method for facilitating place attachment to encourage community building. “Community” is seen as advantageous to student retention at the university level. The desire to foster a sense of community among Utah Valley University (UVU) dance students led the researchers to hypothesize that our sense of community could be improved by utilizing the ability of dance and VEP to create meaningful relationships across time, space, and people resulting in “place attachment” and a more profound sense of community. This piece is the result of research between student and faculty participation in the choreographic process and five places at UVU that are seen as the most meaningful to our dance students as identified through the VEP process. These photos and the responses to them formed the basis for a movement vocabulary. *Sense of Place* is a representation in movement of meaningful places on the UVU campus. Preliminary data collected from the student participants indicates that dance and VEP did contribute to a greater sense of community.

BIOLOGICAL SCIENCES

Uptake of BPA, Phthalates, and Plasticizers by Plants and the Effect on Growth

Jareau Cordell

Dixie State College

While ample research has explored the relationship between bisphenol A (BPA), phthalates, and other harmful plastic additives, such as anti-mony, on animal systems, little attention has been paid to their effects on plants. Consumption of these harmful polymers through primary food sources should be considered and investigated. Radicalized BPA, plastic polymers, and various phthalates from polycarbonate and polypropylene baby bottles were applied to *Brassica juncea* and *Phaseolus vulgaris* to determine if there was an effect on growth. There was an increase in overall root length and stem radius with exposure to the plastic derivatives compared with controls. Height and leaf number also increased in the plasticized water plants versus the control groups. These preliminary data indicate some uptake and growth benefit from plasticizers by *Brassica juncea* and *Phaseolus vulgaris*. The presence of plasticizers in plant stems, roots, and leaves would, no doubt, pose serious public health questions if these substances remain intact and can be transferred from crops into humans and other animals.

BIOLOGICAL SCIENCES**Dinosaurs Know Squat: A Crouching Theropod Trace from the Lower Jurassic Moenave Formation, St. George, Utah and its Implications****Jerry D. Harris***Dixie State College*

Trace fossils (ichnites) made by a 198-million-year-old theropod dinosaur include a traditional, hindfoot-only trackway plus intermittent tail drags interrupted by prints made by the animal squatting in the substrate in a posture very similar to that of modern birds. The trace also includes impressions made by its pelvic region and both hands. The new fossil corroborates the theory that theropods held their palms facing medially, in contrast to manus prints previously attributed to theropods that have forward-pointing digits. Both the avian-style hand configuration and resting behavior therefore evolved very early in the theropod lineage and were inherited later by birds.

BIOLOGICAL SCIENCES

Aquatic Preference of *Hyla arenicolor* in Zion National Park

Jayson Malufau, Seth Mortenson, and Curt Walker

Dixie State College

Canyon tree frogs (*Hyla arenicolor*) are found in many canyons in Zion National Park. We focused on the distribution of these frogs and the environmental factors that could determine their presence. The small pools frequently inhabited by the frogs often had pools without frogs in very close proximity. We measured a variety of aspects of water quality to see if any explained pool choice by adult frogs. Using a field data logger, we measured the temperature, conductivity, and pH of pools with and without frogs. Our sample size was rather small; results showed statistically insignificant correlations among the measured variables and pool choice, although temperature seemed to play a role. We plan to repeat the study next summer to increase sample size; new variables will be measured and the presence/absence of tadpoles will be monitored as well.

BIOLOGICAL SCIENCES**The Presence of Chytridiomycosis in Zion National Park****Dan Sumko, Allystair D. Jones, and Curt Walker***Dixie State College*

Chytridiomycosis, an infection caused by the chytrid fungus (*Batrachochytrium dendrobatidis*), has become a global concern threatening the stability of amphibian populations. The chytrid fungus has spread rapidly across the United States since 1999. The fungus infects the skin of amphibians and almost always results in death. Recent numbers suggest that more than 30% of the world's amphibian populations have already been affected. We provide data on whether this dangerous infective agent has migrated into the populations of the canyon tree frog (*Hyla arenicolor*) in the canyon systems of Zion National Park. To test for the presence of the chytrid fungus, epidermal swabs were collected from 69 frogs, and the samples were tested for DNA markers associated with the chytrid fungus, as well as universal fungal markers. The PCR analysis did not show the presence of the chytrid fungus in ZNP at this time, and we propose that preventive steps be taken to preserve this species that is so valuable to tourist and nature lovers in the park.

BIOLOGICAL SCIENCES

The Direct Effects of Wildfire Retardant on Hatch Rate, Survival, and Development in *Xenopus laevis*

Logan Vance, Brett Riche, Derek Potter, Patrick Bell, Dallas Wright, Jared Garlick, and Rachel Smetanka

Southern Utah University

The African clawed frog (*Xenopus laevis*) is a species of South African aquatic frog found throughout Africa and in specifically introduced populations in many of the western U.S. This species is commonly used as a model of developmental biology because its embryos are large and easy to manipulate and develop rapidly. Phos-Chek LC-95A is wildfire retardant commonly used as an aerial suppressant in much of the intermountain western U.S. Previous studies have demonstrated that fire retardant has no effect on survival rate in adult aquatic invertebrates. The purpose of the current project is to test the direct effects of Phos-Chek LC-95A on hatch rate, embryo survival rate, and development in *X. laevis*. To test hatch rate and survival, various concentrations of fire retardant were introduced to controlled environments simulating a common freshwater pond containing either *Xenopus* eggs or larvae. All concentrations of fire retardant were detrimental to hatch rate and embryo survival. To test the effect of fire retardant on development, various doses were introduced into similar controlled pond environments containing various developmental stages of *Xenopus* larvae. Head width and length were both measured. Fire retardant was also detrimental to development rate in young tadpoles but did not significantly alter growth rate in older tadpoles, suggesting that *Xenopus* tadpoles become increasingly resistant to the effects of fire retardant. These results will be used to support and further develop environmental regulations governing the use of wildfire retardant near freshwater sources.

BIOLOGICAL SCIENCES

Diversity Survey of Soil Bacteria and Fungi in the Wat Punpee Urban Community, Phitsanulok, Thailand

Uriwan Vijaranakul

Rajabhat Pibulsongkram University, Phitsanulok, Thailand

A diversity survey of soil bacteria and fungi in the Wat Punpee Urban Community, Phitsanulok, Thailand, was performed. Wat Punpee community, which occupies an area of 3.5 square kilometers, is the habitat of human beings and other organisms. The purpose of this study was to survey the diversity of soil bacteria and fungi in the soil fauna in this community. A top-view photo that covers the whole area was taken. For sample collection, the whole area was divided into 11 subareas. The sample collection and the identification were done between November 2001 and December 2005. The result showed that there were 14 genera of bacteria: *Alcaligenes*, *Bacillus*, *Clostridium*, *Corynebacterium*, *Enterobacter*, *Escherichia*, *Neisseria*, *Nocardia*, *Proteus*, *Pseudomonas*, *Serratia*, *Staphylococcus*, *Streptococcus*, and *Xanthomonas*. The bacteria in genus *Alcaligenes* was *Alcaligenes faecalis*. The bacteria in genus *Serratia* was *Serratia marcescens*. The bacteria in genus *Bacillus* were *Bacillus cereus*, *Bacillus amyloliquefaeciens*, *Bacillus lentus*, *Bacillus stearothermophilus*, and *Bacillus subtilis*. Twelve genera of fungi were identified: *Aspergillus* sp., *Curvularia* sp., *Fusarium* sp., *Geotrichum* sp., *Monilia* sp., *Neurospora* sp., *Helminthosporium* sp., *Rhizoctonia* sp., *Rhizopus* sp., *Trichoderma* sp., and one unidentified genus. Fifteen species of soil mushroom were found: *Mycena* sp., *Leucocoprinus otsuensis*, *Lepiota rachodes*, *Tylostoma berkeleyii*, *Clavulina carallodes*, *Marasmius maximus*, *Macrolepiota zeheri* (Fr.) Sing, *Lepiota molybdietes* Meyer ex (Fr.), *Lacterius volemus* (Fr.) Fr., *Russula* sp., *Russula delica*, *Coprinus disseminatus* Pers. Ex Fr., *Agaricus trisulphuratus* Berk., *Laccaria vinaceoavellanea* Hongo, *Clavulina cristata* Fr. Schroet.

BIOLOGICAL SCIENCES

Optimization of Medium M9 for *Escherichia coli*

Natalie Weber and William Lorowitz

Weber State University

M9, a defined medium for growth of *Escherichia coli*, was optimized using statistical design of experiments (DOE) with absorbance as response variable. Screening with a factorial design revealed that Na_2HPO_4 , KH_2PO_4 , and NH_4Cl had the greatest effects on growth. Steepest descent analysis suggested optimum values for Na_2HPO_4 , KH_2PO_4 , and NH_4Cl were within the ranges 2.2 to 3.0 g/L, 1.45 to 1.50 g/L, and 0.34 to 0.38 g/L, respectively. Optimum values for these components were determined using response surface methodology. They were 3.0 g/L for Na_2HPO_4 , 1.49 g/L for KH_2PO_4 , and 0.35 g/L for NH_4Cl . The values for these components in M9 medium are 6.0 g/L, 3.0 g/L, and 1.0 g/L, respectively. Comparisons of the modified medium with M9 and verification of the model are underway. This experiment was an excellent application of DOE, combining an educational experience with enhancement of a common medium for growth of *E. coli*.

BUSINESS

Social Networking as a Recruiting Tool

Deborah Carper

Utah Valley University

Social networking used to mean, “It’s not what you know, but who you know.” Since the invention of online social media sites, such as MySpace, Facebook, Twitter, YouTube, and Linked In, the term “social media” has taken on new meaning. Recruiters have the ability to reach further into the candidate pool than ever before, and job-seekers have more options than ever before in locating employment opportunities. Employers are finding ways to brand themselves in the World Wide Web universe in ways that will attract and connect organizations with knowledge-workers and tech-savvy talent. Additionally, recruiters are no longer confined to domestic candidates but now have the ability to reach talent around the world. Human Resource Managers concerned with cost-effectiveness have recognized that newspaper ads and internet job boards are expensive, while social media sites are low-cost or even free. Additionally, as Human Resource management is playing a greater role in maintaining an organizations competitive advantage. Recruiters are screening candidates to a degree never seen in previous generations in order to push the cream to the top. Finding the “right” candidates has almost become an obsession and the information is available for the taking. While it is clear that social media can be an effective recruiting tool, and it is certainly here to stay, it has its downside as well. Recruiters using social media to research candidates may be exposed to information that would be protected by law. Such things as age, religion, ethnicity, education, pregnancy, and sexual orientation are examples. Social networking sites carry considerable personal information that is off limits to professional recruiters. This paper seeks to capture the advantages of using social media as a recruiting tool while avoiding lawsuits from violation of Civil Rights and Equal Employment Opportunity laws.

BUSINESS

Fraud Prevention through the Human Resource Department

David Bogdan

Utah Valley University

In the recent economic recession, ethical lines were blurred, and the misuse of funds and lack of accountability led to poor national confidence in the economy's ability to rebound. The Association of Certified Fraud Examiners forecasts an increase in fraud that could result in billions being lost in the next 12 months. Preventing fraud may be a strong option to quickly repair the confidence lost in the world-wide economy. Based on findings from fraud examiners, the current ethical state of the U.S. is that 30% of the population is dishonest, 40% is situationally dishonest, and the remaining 30% is honest. Applying this to internal fraud, organizations can classify potential and current employees as more likely to commit fraud based on previous statistical evidence. Internal fraud can be prevented through controlling the flow of members into and out of an organization and eliminating unethical elements entering the organization, moderating the opportunities, pressures, and rationales for committing fraud for the situationally unethical elements in the organization, and empowering the ethical elements in the organization.

BUSINESS

The Risk That Wasn't There: Understanding the Role of Derivatives on Reducing and Creating Risk

Leo Chan

Utah Valley University

Traditional finance theory on derivatives suggests that they can be utilized to reduce portfolio and market risk. Such outcome hinges on the assumption that derivatives are used as risk management tools and there is at least one true hedger in the transaction. In the absence of hedgers, however, the trading of derivatives actually creates greater risks for the market. This paper explains how derivatives can reduce overall portfolio risk when used as hedging, and how it could create greater risk if there are only speculators trading derivatives among each other.

BUSINESS

The Mission–Money Tradeoff: Challenges of Government Service Provision by Non-Governmental Organizations in South Africa

Eric C. Darsow and Warner P. Woodworth

Brigham Young University

Many non-governmental organizations (NGOs) struggle to balance donor demands with the actual needs of their target clients, the world's poor. Yet many NGOs reluctantly modify their projects to appease funders because they rely on their donations to survive. This paper draws on months spent in Africa carrying out a field study of interviews and observation of NGO management practices. It explores how an education-focused NGO navigated this tension between funder and client needs in South Africa. This is a country where social development funds are relatively abundant but are raised and disbursed by the government through service provision contracts. This made it unlike its Sub-Saharan African peer countries, which rely heavily on grants from international donors. While the organization remained financially solvent by contracting with various government departments, undertaking these unrelated contracts eroded its ability to promote capacity-building within any particular community, its ostensible mission. Based on six months of on-site data collection, this paper describes how the NGO navigated this tradeoff and uses organizational identity theory to evaluate new approaches for more effective NGO–government collaboration.

BUSINESS**Changes in the Structure of Utah's Economy,
1850–2008****L. Dwight Israelsen***Utah State University*

Between 1850 and 1890, Utah's economy was diversified, with its industrial structure and its demographic structure looking much more like those of the overall U.S. economy than of other Mountain West states. This diversification helped Utah avoid the prolonged periods of economic instability associated with changes in world commodity prices that created serious hardships in surrounding states. By the early 20th century, however, Utah's economy was becoming less diversified and more dependent on extractive industries, particularly mining. This structural change created an economy that was less stable, in general, than the overall U.S. economy. By 1960, Utah's economy had become much more dependent on government employment and much less dependent on manufacturing than the U.S. economy. The structural changes that have occurred in Utah's economic structure since the mid-20th century have created a more diverse and more stable economy that once again closely resembles the overall U.S. economy in the early 21st century.

BUSINESS

Complex Job Structure and Intelligence: A Research Proposal

Christopher Nelson

Utah Valley University

While engaging in complex activities, there is an increase in fluid intelligence. This increase in intelligence is facilitated by neural plasticity that takes place within the lateral prefrontal cortex. This paper is a research proposal that will either support or not support the relationship between complex job-like activities and fluid intelligence, as facilitated by neural plastic mechanisms in the lateral prefrontal cortex. This proposal outlines literature to support this thesis, methods for testing neural plasticity and intelligence, possible participant qualifications, and other details that will be useful when conducting this study. The information gained from this study may result in greater awareness of the importance of engaging in complex activities, specifically those found in the workplace.

BUSINESS**Engaged Learning and the Entrepreneurial Mind Set****Peter B. Robinson***Utah Valley University*

While some argue that entrepreneurship cannot be taught, it is usually the entrepreneurial mindset they would insist is unreachable. This mindset is often based on older theories that are usually outdated or inconsistent with current theories and assumptions. A current theory-based model of mindset, as exemplified by the Entrepreneurial Attitude Orientation (EAO) is considered as an exemplar of entrepreneurial mindset. Engaged learning models are explored in terms of both the elements of good engaged learning and some of the steps involved in engaging students in the learning process. Engaged learning is conceptually and empirically tied to changes in entrepreneurial mindset as measured by changes in student EAO scores. Finally, two examples of engaged entrepreneurship education are provided and related back to the elements of engaged learning.

BUSINESS

Human Resource Management and Multinational Corporations: A Utah Perspective

Michelle Spencer

Utah Valley University

As companies grow, they search for effective avenues by which to successfully expand their consumer base and decrease operating costs. Many companies institute global operations by establishing multinational corporations, international joint-ventures, and other such forms of international business. In so doing, they take on the risks, responsibilities, and challenges inherent to the international business environment. To sustain a competitive advantage and mitigate risks associated with global operations, firms must allocate sufficient time, effort, and money to establish effective human resource management practices. As Utah-based companies prepare to expand operations in other countries, they will encounter myriad obstacles including those connected to hiring decisions, talent management, and international compliance. In this research, I will use data gathered by the International Trade and Diplomacy Office, the World Trade Commission, and the United States International Trade Commission to examine the risks and challenges facing Utah-based multinational companies. The research will focus primarily on possible compliance issues, and their impact on human resource departments. Additionally, I will utilize other secondary research to help explain the causes behind current barriers, as well as provide a framework that companies can use to decrease their risks.

BUSINESS**A Comparative International Look at Differences in Job Quality and Worker Satisfaction: The Case of France and Germany****Michelle Spencer and Jonathan H. Westover***Utah Valley University*

Countless studies have examined the various determinants of job satisfaction. However, there has been no significant research conducted to date that has examined the country-level structural and contextual conditions that impact workplace conditions, and thereby worker satisfaction and its determinants. In this research, we will address the existing gap in the academic literature on job satisfaction. We will use a comparative international methodology to examine similarities and differences between France and Germany from 1997 to 2005. First, we will use a variety of bivariate and multivariate descriptive statistics and procedures, as well as ordinary least squares and ordered probit regression analysis, to test for statistically significant variations across the two countries. Second, to move beyond the existing research of social psychologists and organizational behavior researchers, we will utilize descriptive country-level comparative data to include important macro cross-national factors that may directly influence working conditions and the perceptions of workers. Finally, we will compare and combine previous cross-disciplinary theoretical work surrounding globalization and the role of the state to examine and explore these macro-level variables behind country similarities and difference, resulting in differences in work quality characteristics and the perceived worker satisfaction in France and Germany.

EDUCATION

Integrating Evolutionary Scaffolding and Authentic Learning into Business Classes

Darrell Coleman

University of Utah

The concepts in a business class are often complex and ambiguous. How can the business instructor enhance learning given such conditions especially when they are now faced with a generation of Millennial learners that tend to be either risk averse and safety-oriented or confident and special-oriented? In this paper I draw from authentic learning theory and evolutionary scaffolding theory to suggest a new approach called experiential evolutionary scaffolding. With experiential evolutionary scaffolding, instructors construct student learning along expert, reciprocal, and self-scaffolds while simultaneously incorporating authentic learning experiences that leverage hierarchies of task complexity. This method offers an innovative yet effective approach to enhance learning for Millennials in business classes. While this approach is particularly useful for business classes, experiential evolutionary scaffolding can be applied to a wide range of higher education disciplines.

EDUCATION**Popular Culture as University Pedagogy:
Academics or Just Plain Fun?****AmiJo Comeford, Nancy Ross, and Chelsi Sutton***Dixie State College of Utah*

Because so much of popular culture, particularly television, draws on literary and artistic allusions, engaging significant cultural narratives just as regularly as it depicts visually stimulating scenes and characters, it provides academics with the ideal platform to bridge an at-times looming gap for students whose academic experiences can no longer be separated from the popular culture world literally at their fingertips. This panel explores how various television shows and popular culture mediums function as texts to be addressed in the wider field of narrative, literature, and art since critical analysis of visual narratives in our culture is often related to our literary and artistic history and cultural consciousness. Panelists will offer practical pedagogical strategies to overcome the permeable barrier between academic discourse and lived experience in the college classroom through the venue of popular culture.

EDUCATION

The Weakening of Tenure and Post-Tenure Review: An Issue Analysis

John Hill

Salt Lake Community College

Tenure has come under increasing attack in American higher education. While some may deny the presence of an all-out attack, few can deny a trend toward weakening of the power or significance of tenure, coupled with an overall decrease in the prevalence of tenure. Great Britain has already abolished tenure, and the argument could be made that strategies such as the increasing post-tenure review are simply a more stealthy approach to tenure abolishment in the United States. This author analyzes the legal, ethical, and practical aspects of these issues, and presents a reasonable approach toward amelioration of the issue of weakening tenure.

EDUCATION

Using Digital Storytelling to Promote Classroom Curriculum

Talitha Hudgins

Utah Valley University

Encouraging teachers to use technology in the classroom has been a difficult process. Many believe technology integration is difficult and at best more trouble than it is worth. The purpose of this presentation is to demonstrate the ease of applying digital video technology.

There have been various technology tools developed enabling teachers to utilize different approaches and tools to help students construct their own knowledge. One of these powerful technology tools is the multi-media production of digital storytelling.

Digital storytelling in the classroom provides students with a sense making process and the ability to share deep understanding of the subject matter. Students learn to think and write about people, places, events and problems. They develop communication skills, acquire new media literacy and information technology skills including capturing and editing digital photos, recognizing different image formats, recording, writing scripts and developing storyboards, as well as using audio clips and learning to search the Internet for appropriate and accurate information.

EDUCATION

John Wesley Powell: Soldier, Professor, Scholar, Explorer, Geologist, ...Development Officer and Lobbyist?

Peter L. Kraus

University of Utah

John Wesley Powell's place in history will be forever noted by his explorations of the Green and Colorado Rivers, his expedition of the Grand Canyon, as well as his role in the founding of the Bureau of Ethnology at the Smithsonian Museum and his tenure as Director of the U.S. Geological Survey. However, the question must be asked—in the initial planning stages of his early expeditions out West after his service as an Officer in the Union Army during the Civil War, who funded Powell and why? This paper will explore Powell's fundraising talents, establishing him as early player in the field of American philanthropy and describing his successful lobbying efforts for government funding in higher education and scientific exploration during the late 19th century.

EDUCATION

After-School Programs: A Successful Partnership of Westminster College and Youth City

Joyce Sibbett, Shamby Polychronis, Tim Carr, and Elizabeth Rich
Westminster College

After-school programs hold promise for providing a safe and supportive environment for preteens and teens; however, funding to accommodate adolescents across the country is limited. In an effort to increase awareness of the importance of after-school programs, which includes effective parent involvement, Westminster College School of Education has partnered with Youth City, an after-school program in Salt Lake City. Westminster pre-service teachers do fieldwork that includes observation, lesson planning and implementation, and parent interviews at the four Youth City locations in Salt Lake City. In the past two years, the outcome for Westminster students has been an awareness and appreciation for the importance of creating safe havens for preteens and teens to develop self confidence, respectful relationships, and varied interpersonal and academic skills that benefit them in school and beyond. Youth City students have also benefited from the lessons and involvement of Westminster students.

ENGINEERING**Numerical Investigation of Liquid Flow through Micro-channels with Post Patterned Super-hydrophobic Walls****Abolfazl Amin***Brigham Young University*

We numerically investigate the influence of post patterned super-hydrophobic surfaces on the drag reduction for liquid flow through micro-channels. Hydrophobically coated surfaces exhibiting micro-scale structures such as ribs/cavities and posts/cavities can significantly reduce the liquid–solid contact. Preventing liquid from entering the cavities increases the fraction of liquid–gas interface, which results in reduced surface friction. Fully developed laminar flow is considered here. The effects of cavity fraction (the ratio of cavity area to total surface area) and relative module width (ratio of post/cavity repeating length to channel hydraulic diameter) on the slip length and on the Darcy friction factor–Reynolds number product, fRe , was explored numerically for the post structured hydrophobic walls. The cavity fraction and relative module width are allowed to vary from 0.5 to 0.9998 and from 0.01 to 1.5, respectively. In general, as both cavity fraction and relative module width increase, fRe decreases. The present results are compared with those for surfaces exhibiting rib/cavity patterns that are parallel and perpendicular to the flow direction. At high cavity fractions, the post/cavity structuring produces larger slip-length and greater reduction in fRe than either parallel or perpendicular rib/cavity structures. The results are also compared with scaling laws previously published in the literature.

HEALTH, PHYSICAL EDUCATION, AND RECREATION

A Correlation of Collegiate Baseball Players Posture and Individual Baseball Statistics

**Bret Boyer, Corey Rawlins, Leoni Lobendahn, Jason Slack, and
Mike Bohne**

Utah Valley University

Justification: Postural assessment is a commonly used technique to identify and monitor musculoskeletal norms, anomalies, and/or imbalances. Sport-specific and position-specific training may lead to such imbalances, which in turn may lead to altered (enhanced or diminished) performance.

Design: This study was a convenience group used to establish correlative data between posture and individual baseball statistics.

Methods: Twenty-eight Utah Valley University baseball players completed a demographic questionnaire. Participants were photographed with anterior, bilateral, and posterior views with only shorts on while standing behind a plumb line and in front of a posture grid. The athletes' postures were scored then compared with personal demographics and individual statistics.

Results/Conclusions: The overall postural score showed no significant relationship; however, individual components of the overall score suggests a relationship to some individual statistics. A larger, more heterogeneous population and more detailed analysis/classification of posture may demonstrate a higher correlation and probability.

HEALTH, PHYSICAL EDUCATION, AND RECREATION
Comparable Study: Running the 1.5-Mile Run on a Treadmill Versus Running the 1.5-Mile Run on an Indoor Track

M. Vinson Miner and Jason V. Slack

Utah Valley University

Both quantitative and qualitative components were analyzed to compare running times of a 1.5-mile run on an indoor track with the running times of a 1.5-mile run on a treadmill. Running times were compared to determine if there are any significant time differences or psychological elements between the two methods of running. The research project tested and rendered several runs (both on the treadmill and on the indoor track) over a 7.5- to 15-week period of time. No significant difference between average treadmill time (13:14) and average track time (13:25) were determined. In addition, the qualitative components were observed, analyzed, and documented. Participants' psychological responses, such as motivational, emotional, attitude, likes/dislikes, and preferences, were tabulated and compared. In conclusion, no significant difference existed between running times on a treadmill and those on the indoor track, but psychological preferences varied greatly on the two methods.

LETTERS—LITERATURE**Victory of the Ash Buttocks: The Role of Hybridity in Colonization, Decolonization, and Postcolonization****Jennifer Gibb and Sue Bennett***Dixie State College*

The creation of the colonial hybrid as a political tool played an integral part in the conquest of indigenous lands by colonial rulers as well as the ability to maintain control of these locations. Eventually hybridity turned on its creators and armed native peoples with the ideologies and knowledge to overthrow colonial powers. This gave rise to a postcolonial period in which the internalization of hybridity left lingering effects, both sociological and psychological, for the once-colonized people. This timeline of hybridity can be traced through *Things Fall Apart* by Chinua Achebe, *Death and the King's Horseman* by Wole Soyinka, and *The House of the Spirits* by Isabel Allende. These works of literature provide the opportunity to experience hybridity in states, forms, and intensities different from our own and affords the ability to understand colonialism in the emotionally charged circumstances in which they occurred.

LETTERS—LITERATURE

**The West's "Immoralism": Gide's Latent Message
in *The Immoralist***

Dustin Jackson

Dixie State College

This essay explores how André Gide's *The Immoralist* questions the dominant hegemonic ideology concerning one's sexual attraction and the West's dealings with the East. By raising questions within 20th-century Western society, André Gide constructs Michel, a character that does not know what he wants. He spends much of the novel yearning to be with younger Arab boys. One cannot be sure of his wishes to engage in homosexual pedophilia with these boys, but he holds no attraction to the woman to whom he is married. In addition, those boys must notice his frequent lustful gazes, and those gazes may have been part of the problem that led to the unhappiness of many of the characters, which prohibits the expression of humanist endeavors. This essay concludes with the concepts of empire and how greed drives people's motivation and the world's desire for colonialism and imperialism, which makes one "immoral."

LETTERS—LITERATURE

**A Mean and Ungentlemanly Act: Casaubon's
Passive Aggressive Maneuvering in George Eliot's
*Middlemarch***

Randy Jasmine

Dixie State College of Utah

In the infamous catechism of rational self-interest from Balzac's *Pere Goriot*, the Machiavellian criminal Vautrin boasts, "I'm like a great poet, but I don't write my poems: my poems are what I do, what I feel" (86).¹ No one would ever mistake the blustery Vautrin for George Eliot's withered and inept scholar Edward Casaubon, but this statement can be productively examined in relationship to both characters. While Vautrin clearly comes across as a pragmatic character, Casaubon hides his personal desires within mummified layers of bitterness, scorn, and silence. Casaubon's greatest achievement, the work for which he will be known to posterity, is not his unwieldy and ultimately unfinished *Key to All Mythologies*; instead, it is the codicil he adds to his will that disinherits his wife Dorothea if she marries his cousin Will Ladislaw. This legal tactic is shrewd, merciless, and effective—adjectives that cannot be applied to the rest of his life's work.

In this paper, I argue that Casaubon attempts to make up for all of his other failings by revealing his jealousy and codifying his resolve in the legal document he leaves behind. As Eliot builds her great realist project, Casaubon's egoism (a trait held by all of the characters in the novel) is presented as being particularly selfish and malicious. I also suggest that, from a practical standpoint, the passive aggressive nature of Casaubon's actions make them far more effective than any open protestations would have been. Just as Vautrin hides behind his aliases and disguises, Casaubon is able to secrete his intentions toward his wife and his cousin behind the blanket of his pathetic failures. Mr. Casaubon's legal amendment of his will is his great poem.

¹ Translated by Burton Raffel.

LETTERS—LITERATURE

Jules Verne's *The Castle of the Carpathians*: Gothic Castles and Science Fiction in a Literary Landscape

Ace G. Pilkington
Dixie State College

The Castle of the Carpathians is a good novel by a great writer, and as usually happens with such works—Shakespeare's *King John* or *Cymbeline*, for instance—it has received far less attention than it deserves. The sheer size and the unique shape of Jules Verne's reputation both militate against fair treatment. However, Jules Verne is currently under attack or perhaps, more accurately, he has become a battleground in the continuing wars of literary critics, and out of that plentiful shedding of ink and wounding of reputations may well come just the attention that *The Castle of the Carpathians* ought to have. Ironically, a novel about (among many other things) the fierce dangers of celebrity may benefit from Verne's own star status.

LETTERS—LITERATURE**Gender Constructions in *Story of the Stone*****Nathaniel R. Ray and Margaret Wan***University of Utah*

This paper will analyze the gender constructions in *Story of the Stone*, arguably the greatest novel in pre-modern China. The narrative provides a sympathetic view of behavior counter to Confucian norms. The central character, Jia Baoyu, represents an amalgamation of male and female characteristics that lead him to neglect his role as male heir to the household.

The garden in the novel accentuates Baoyu's feminine qualities while allowing him freedom to pursue activities antithetical to Confucian duty. As his father, Jia Zheng is emblematic of Confucian male propriety; beating Jia Baoyu in chapter 33 explicates upon this disparity between the two. We use Foucault's concept of "the gaze" to show that Baoyu's relationship with Confucianism is a dialectic on the power of Confucian hegemony.

Baoyu's actions, which run contrary to traditional gender appropriation, are foreshadowed in the frame story while also reflecting historical change in 18th-century China.

LETTERS—PHILOSOPHY**Arab and Muslim Americans: Two Diverse Minorities****Kholoud Al-Qubbaj***Southern Utah University*

Arab and Muslim Americans are the two most rapidly growing minorities in America. The diversity among these two groups is still misunderstood and tangled. A major difference between the two groups is that Arabs are an ethnic group, while Muslims are a religious group. Also, most Muslims are not Arabs, while Arabs are mostly Muslims. The Muslim populations around the world is approximately 1.3 billion people (about 1/5 of the world population) while the Arabs are about 300 million (equal to the population of the U.S.). The majority of Arab Americans are not Muslims. In fact, a little more than three quarters of them are Christians from different denominations, including Catholic, Greek Orthodox, Maronite Christian Church, and Coptic. Arab American immigrants and their descendants come from the 22 countries that comprise the Arab world. Most early Arab immigrants to the U.S. were Christian. Islam has only been practiced in North America since the first century of European settlement. The early immigrants were often a working class, but recent immigrants are professionals and business people who are prosperous economically compared with other racial and ethnic groups. Arab Americans are considered highly educated. Their children attend both public schools and Islamic private schools. Children attending public schools encounter the type of adjustment experienced by those of a religious faith different from the dominant one of society. When a negative political event involving Arabs occurs, discrimination against Arabs rises. Muslims in the U.S. often express the view that their faith encourages political participation. The Palestinian–Israeli conflict plays an influential role in the U.S. foreign policy; therefore, there is a clear distancing that one can observe between the major political parties and Muslims and Arab Americans. One of the most visible Arab Americans in politics, Ralph Nader, tried to open presidential politics to a true alternative to the two-party system.

LETTERS—PHILOSOPHY**Pedro Salinas en Utah****Andrew Bishop***Brigham Young University*

Pedro Salinas, a poet from Spain's Generation of 1927, resided in the United States during and after the Spanish Civil War. While teaching in various schools across the country, he attended conferences showcasing his literary criticism, poetry, and playwriting. He corresponded prolifically with his wife Margarita Bonmatí. On one occasion, he traveled to Los Angeles, California, to attend a literary conference, but along the way he traveled through Missouri, Colorado, and Utah visiting various landscapes, national parks, and cities. He chronicled his impressions in letters to his wife. These impressions follow a theory of tourism developed by Pedro Salinas. They also follow the idea of intentionality—a phenomenological concept in which appearances have ontological meanings, especially as explained by the French philosopher Maurice Merleau-Ponty. The letters Salinas writes and the appearances he intends show his focus and soul are his wife. These meditations help Salinas to commune with his beloved. The paper retraces Salinas's travels through Utah using historical references, contemporary figures, his letters, and a few of his poems.

LETTERS—PHILOSOPHY

The Women in *Parzival*: An Experiment in Jungian Literary Criticism

James Harrison

Southern Utah Univeristy

No matter how comfortable one feels with medieval literature, there lingers over the whole enterprise the feeling of “otherness.” Seen from a modern perspective, things move differently in the romances and epics of the Middle Ages. Characters react in ways that no allowance for the mores of a past age can explain. While there are many explanations for this, one of the most important is that medieval literature deals with allegory and the literary phenomena associated with allegory in a much more transparent and candid fashion than modern literature. There are, for example, few if any modern works that could make place for the dialogue that occurs at the beginning of Book IX in Wolfram’s *Parzival*:

- “Open up!”
- To whom? Who are you?
- “I want to come into your heart to you.”
- Then it is a small space you wish.
- “What does that matter?...”
- Oh, it is you, Lady Adventure? How fares that lovable knight?

Or what modern work has a figure like Sigune. While she engages in very important dialogs with Parzival, the thing that one remembers about her is not her words but her image. When the reader remembers her, he/she remembers a still life. It is the powerful, timeless image more than the word that is important here. It is, to use a term introduced by G.G. Jung, archetypal. And Sigune is only one such female image in Wolfram’s work. There are others. One senses the same characteristics, for example, in Herzeloide, Cundwiramur, Cundrie, and Orgeluse to mention only the most obvious. These characters are freighted with characteristics that lift them above Northrup Frey’s high

mimetic mode. Without being mere types, they take on allegorical significance.

Ernst Neumann, in his book, *The Great Mother: An Analysis of the Archetype*, suggests how the numinous feeling that so often accompanies archetypal characters develops in the human psyche. Not only does he investigate the morphology of this archetype, but he devises a particularly useful method for organizing its many manifestations. He uses a circle in which the two primary functions of the feminine archetype, the nurturing and the transformative, serve as two axes that intersect at obtuse angles and divide the circle into quadrants. Each axis has a positive and a negative pole. He then gives examples from various mythologies of certain characters that represent various points on the circle. There is the positive transformative function, e.g., the muses, and the negative transformative function, e.g., Circe. There is a positive nurturing function, e.g., Demeter or Isis, and a negative nurturing function, e.g., Hecate or Kali.

This paper will build on work that was presented to the Rocky Mountain Modern Language Association convention in Snow Bird, Utah, in the fall of 2009. In it I propose to use Neumann's idea of a circular matrix to map several important female figures in *Parzival*. By fixing them on a two-dimensional matrix, it will be easier to see their relationship to Parzival and to each other. I will then try to draw some conclusions concerning them as symbols of Neumann's Great Mother and its importance to literature in general and the medieval romance in particular.

LETTERS—PHILOSOPHY

Witch Hunt: Genocide in Middle Age Europe

Jorge Nisguritzer

Utah Valley University

The word genocide can be associated with different fields, such as culture, ethnicity, and gender, among others. It is also a process that destroys ideas, freedom, and ultimately lives. One can conclude that genocide is the last step or consequence in a chain that starts with intimidation and dominance. In other words, when dominance is not perceived by the oppressor as having enough power, genocide takes place. According to Ervin Staub, “Genocide is an attempt to eliminate, directly by killing them or indirectly by creating conditions (e.g., starvation) that lead to their death, a whole group of people.” The U.N. Genocide Convention defines genocide as “acts committed with the intent to destroy in part or in whole a national, ethnic, racial, or religious group as such” (368). Considering this definition, the world has seen many genocides. Among the most famous examples are the Nazi Holocaust during World War II, which caused the extermination of million of Jews, and the Spanish Inquisition, which sought the destruction of all who lived in Spain but did not declare themselves Christians. However, there was another genocide, which I refer to as “womenicide,” that happened in Europe, namely between the 14th and 18th centuries. This was the extermination of women based on superstitions or religious beliefs of the time. This paper focuses on the various aspects of the violence and persecution that led to the killing of European women in that particular period of time. I analyze the psychological plot that was organized by the Catholic Church against the female sector accused of being witches or practicing witchcraft. I consider also the actions taken by the Church in an attempt to keep women controlled and oppressed.

LETTERS—PHILOSOPHY

Parzival and the Hero Cycle

Jessica Pierce

Southern Utah University

The purpose of this paper is to show that there is more to becoming a hero than the journey alone; a hero must develop psychologically and philosophically before he can claim the title of “hero.” Plato’s tripartite soul theory states a person must learn to balance reason, the spirited element, and bodily appetites and E.R. Dodds’s shame and guilt society theory states that the two societies are separated by the differing standards of each society; for example, the shame society is concerned with upholding a good reputation while the focus of the guilt society is maintaining personal standards. I believe that combining the tripartite soul and shame and guilt society theories makes up the psychological and philosophical background of the hero. To these theories I will be adding my own hero cycle, which maps out a hero’s development through the course of a story. I will also introduce the grace line, which is the falling and redemption of a hero as he moves through the hero cycle.

By examining two characters from Wolfram von Eschenbach’s *Parzival*, Parzival and Gawan, I will attempt to illustrate how both of these characters develop through the course of the story on the hero cycle, how each character is an example of both the shame and guilt societies, when they cross the grace line, and how they balance the tripartite souls.

LETTERS—PHILOSOPHY

***Kudos or Straight Jacket* for Sven Birkerts! The Fate of Reading and Readers in the Electronic Age**

Kay Smith

Utah Valley University

Although once believed to be an electrifying boost for the distribution of knowledge and information, technology may have actually, and ironically, sedated the masses and helped generate a culture of non-thinkers and superficial readers. Fifteen years ago, literary critic Sven Birkerts wrote, not as a nostalgic romantic but as a realist, and indicted the electronic postmodern age as the eventual death of books and enculturation of vigorous readers. Has Birkerts's ideology remained valid, and have educators seen the habits of readers who have slipped blissfully into digital literary erosion? Come, listen, and decide for yourself.

PHYSICAL SCIENCES**Defect Concentration Dependence of
Inhomogeneous Broadening in PAC Spectroscopy****Mike Adams, Austin Bunker, Jeffery Hodges, Tyler Park, Michael
Stufflebeam, W. Evenson, P. Matheson,***Utah Valley University***and M. O. Zacate***Northern Kentucky University*

Defects, such as vacancies in crystals, affect the electric field gradient (EFG) tensor components at probe nuclei and can thus perturb nuclear phenomena such as double gamma emission used in perturbed angular correlation (PAC) studies. We model the net EFG from a random distribution of vacancies combined with a single trapped vacancy in a near neighbor position to a probe nucleus, for various concentrations of vacancies. We find the statistical probability distribution of appropriately transformed EFG components to be fit best by gamma distributions, parameterized by k and q . These are then used to model inhomogeneous broadening (IHB) of the PAC spectrum, $G_2(t)$. We have investigated IHB in simple cubic, body-centered, and face-centered cubic crystal structures for various concentrations of vacancies (.1% to 15%). By characterizing the concentration dependence of k and q , we are able to reconstruct $G_2(t)$ for various defect concentrations and compare them with their original simulated $G_2(t)$ spectra to check for self-consistency. We can then use the derived probability distributions to examine the concentration dependence of experimental broadened PAC spectra.

PHYSICAL SCIENCES

Fabrication and Testing of a Strain-Based Carbon Nanotube Magnetometer Structure

D.D. Allred, J.A. Brame, J.E. Goodsell

Brigham Young University

and S.A. Getty and Y. Zheng

National Aeronautics and Space Administration (NASA)

A test structure for a prototype nanoscale magnetometer exploiting the strain sensitivity of Single Walled Carbon Nanotubes (SWCNTs) has been fabricated. The nanotube magnetometer would boast reduced dimensions, mass, and power requirements compared with a Fluxgate magnetometer. Dramatic resistance increase with strain has been previously reported for individual nanotubes, and this magnetometer design concept seeks to extend this strain-resistance property to an “as grown” ensemble of SWCNTs. Measurements of a test structure show a correlation between applied magnetic field and device conductivity. This correlation indicates an increase in conductivity with strain to the network of nanotubes; candidate mechanisms for this behavior are discussed.

PHYSICAL SCIENCES**Constraint Preserving Boundary Conditions In
General Relativistic Magnetohydrodynamics****Michael Besselman***Brigham Young University*

Astrophysically, we observe many compact objects, such as neutron stars, which in addition to being examples of strong field gravity, also carry a magnetic field. We are interested in simulating the evolution of such objects using general relativistic magnetohydrodynamics (GRMHD). An important aspect in these models is ensuring that physical constraints are everywhere satisfied during these computations. We have successfully imposed consistent boundary conditions to maintain the vanishing of the divergence of the magnetic field. We compare the differences in a system when these conditions are and are not applied.

PHYSICAL SCIENCES

Inhomogeneous Broadening in Perturbed Angular Correlation Spectroscopy

Austin Bunker, Mike Adams, Jeffery Hodges, Tyler Park, Michael Stufflebeam, William Evenson, Phil Matheson, and Matthew Zacate

Utah Valley University

Our research concerns the effect of a static distribution of defects on the net electric field gradient (EFG) within a crystal. Defects such as vacancies perturb the spatial probability distribution of emitted gamma rays from radioactive probe nuclei within a crystal. These defects produce a net EFG at the site of a probe that interacts with the electric quadrupole moment of that nucleus, causing a torque on the nucleus and a corresponding perturbation of emitted gamma rays. The EFG is strongly concentration dependent, and the resulting perturbed angular correlation (PAC) of the gamma rays is seen as damping of the perturbation function, $G_2(t)$, in time and a broadening of the spectral peaks in its Fourier transform, $G_2(\omega)$. We have used computer simulations to study the probability distribution of EFG tensor components of various cubic structures to uncover the concentration dependence of $G_2(t)$. This in turn can be used to analyze experimental PAC data and quantitatively describe the correlation of defects to properties of the crystal.

PHYSICAL SCIENCES**Measurement of the Complex Index of Refraction for Uranium Dioxide in the Extreme Ultraviolet****Heidi Dumais, R. Steven Turley, David Allred, Zephne Larsen, Keith Jackson, and Alison Wells***Brigham Young University*

The Brigham Young University Extreme Ultraviolet (XUV) research group recently visited Berkeley's Advanced Light Source to measure reflectance and transmittance in the extreme ultraviolet for a diode sputtered with a uranium dioxide film (approximately 20 nanometers thick). We left half of the diode uncoated. The reflectance data for the coated side has been fit to a model to determine the thickness of the film. Fitting the transmission data to a model and combining this with the thickness calculation from the reflectance data yielded the complex part of the index of refraction for uranium dioxide in the extreme ultraviolet region at every tenth of a nanometer in wavelength. Similar analysis performed on the uncoated data using tabulated indices of refraction for silicon dioxide and silicon provided an estimate for the thickness of the silicon dioxide film and the "dead layer" for the diode. These values provide researchers with valuable information for modeling, design, and fabrication of optical systems in the extreme ultraviolet. This data will aid XUV researchers in designing optical systems allowing smaller microelectronics devices, more efficient solar cells, higher resolution optical microscopy, and better astronomical imaging systems.

PHYSICAL SCIENCES

Characterization of Storm Water Runoff in the Coal Creek Drainage Basin

Shannon Force, Samantha Huntsman, Darren Dillard, Lauren Bunker, Jordan Leach, Kasidy Grimshaw, Kim Weaver, and Ty Redd

Utah State University

Coal Creek is a small, perennial stream, fed by mountain runoff, which is located in the Coal Creek Drainage Basin in the Cedar City, Utah, area. The increasing urbanization of the Cedar City area puts the water quality of this basin at risk. This study focuses on characterizing pollutants from non-point sources and their impact on the water quality of Coal Creek and the organisms living within it. Analytes of interest include common anions, mineral metals, pH, turbidity, conductivity, and pesticides. The determination of pollutant concentrations in runoff and affected surface water will be beneficial to understand basic sources of non-point source pollution. It is hoped that this study will help to better understand the effects of population growth and urbanization on the water quality of Coal Creek and the organisms living within it.

PHYSICAL SCIENCES

The State of Physics Teacher Preparation across the Nation: Brigham Young University's Highlights in the National Survey

Duane Merrel

Brigham Young University

In March 2009, Brigham Young University (BYU) was visited by a national task force studying the role that universities are playing in preparing secondary physics teachers. Findings from the National Task Force on Physics Teacher Preparation will be discussed. The task force did follow-up interviews and asked further questions while considering BYU's efforts in the preparation of secondary physics teachers. BYU's efforts will be discussed.

PHYSICAL SCIENCES

Is There a Black Hole in the Starburst Merger IIZw96?

Victor Migenes, Kirstin Coopriider

Brigham Young University

and R. Coziol

University of Guanajuato

The merging of galaxies is an excellent environment for the study of events such as extreme starbursts or active galactic nuclei (AGN).

OH megamasers (OHM) probe these extremely dusty and molecular-rich regions. By determining the structure and positional information of these OHM, we can understand the nature of the merger and if there are indeed AGNs or starburst occurring. There have been exceptional surveys in the optical and radio determining the locations and environments of these masers; however, the classifications are sometimes in conflict and require higher-resolution studies to understand more clearly what is occurring in the merging galaxy system.

IIZw096, with a very interesting morphology, has been observed optically by the San Pedro Martir 1.5 m telescope with BVRI filters and even the Hubble Space Telescope. These observations are being compared with radio observations done by the MERLIN and the EVN array. From the radio and optical data it has been determined that the OHM emission may be associated to what seems to be an AGN core. The mass of the core is a few million solar masses. The structure itself has just barely been resolved and requires further analysis to understand how its structure correlates to the optical environment and more importantly the evolution of the merger.

PHYSICAL SCIENCES

The First Science from the Remote Observatory for Variable Object Research (ROVOR)

J. Ward Moody, Cameron Pace, Richard Pearson III, Brett Little, Evan Hansen

Brigham Young University

and Jonathan Barnes

Salt Lake Community College

and Alberto Sadun

University of Denver

The Remote Observatory for Variable Object Research (ROVOR) is an 0.4-m RC Optical telescope sited in Millard County, Utah, that is run remotely through an internet link from the Brigham Young University campus. It was built to monitor classical variable objects and conduct specialized surveys. We report on the first complete year of scientific operations. Our successes include improving the BRVI photometric accuracy of the optical standards around the northern TeV blazars, finding half a dozen brightening events in the blazar Mkn 501, and making the first observations of a survey for microquasars in the galactic plane.

PHYSICAL SCIENCES

Successful Sampling Strategies for Characterizing Particles from Point and Diffuse Area Sources Using Lidar

Kori D. Moore, Michael D. Wojcik, and Randal S. Martin

Utah State University

Ground-based remote sensing technologies such as scanning lidar systems (light detection and ranging) are increasingly being used to characterize ambient aerosols because of key advantages [i.e., wide area of regard (10 km^2), fast response time, high spatial resolution ($<10 \text{ m}$), and high sensitivity]. Scanning lidar allows for three-dimensional imaging of atmospheric motion and aerosol variability. Energy Dynamics Laboratory at Utah State University, in conjunction with the U.S. Department of Agriculture–Agricultural Research Service, has developed and successfully deployed a three-wavelength lidar system called Aglite to characterize particles in diverse settings. Generating meaningful particle size distribution, size-segregated mass concentration, and emission rate results based on lidar data is dependent on strategic onsite deployment of mass-based and size distribution point sensors and characterization of local meteorology. Based on over five years of field and laboratory experience, we present some successful strategies and lessons learned regarding the use of lidar to characterize and map aerosols from different facilities/operations.

PHYSICAL SCIENCES**Analysis of Anomalous Film Growth when Yttrium Oxide is Exposed to Vacuum-Ultraviolet Light****Devon Mortensen, Alison Wells, Thomas McConkie, and David D. Allred***Brigham Young University*

We have recently found that exposure under a vacuum-ultraviolet (VUV) lamp causes a reactively sputtered yttrium oxide film to increase in thickness with a decline in refractive index. This result was completely unexpected and therefore demanded further investigation. We have experimentally observed the following:

1. These effects are noticeably absent under the same conditions for a plain silicon wafer.
2. When placed in a furnace the changes rendered to the yttrium oxide sample are mostly reversed. In the VUV lamp, the sample then increased in thickness.
3. A film placed in a plasma cleaner does not show this increase, and such a sample does not show any increase when subsequently exposed to VUV light.

We are attempting to elucidate this mystery by examining transmission electron micrographs of similarly grown yttrium films. We have also expanded our study to Sc_2O_3 , which lies just above yttrium in the periodic table.

PHYSICAL SCIENCES

Magnetic Domain Memory: A Radius-Selective Analysis

Joe Nelson, Karine Chesnel, Eric Fullerton, Steve Kevan, and Brian Wilcken

Brigham Young University

Microscopic magnetic domain memory has been shown to be induced in exchange-bias thin films. We have expanded the methodology previously used to quantify this memory by utilizing radius-selective correlation of x-ray resonant magnetic speckle scattering. Using this technique, we can obtain information about the spatial dependency of the magnetic domain memory at the nanometric scale, which is essential to understanding the details of this phenomenon. The challenges encountered in this specialized cross-correlation process and our solutions are described in detail.

PHYSICAL SCIENCES**Neutron Star Kick due to Asymmetric Neutrino Diffusion in a Forming Neutron Star with Strong Magnetic Field****Alexander Panin***Utah Valley University*

Many neutron stars move with high velocity (several hundred km/sec) suggesting asymmetric collapse of a supernova in which they were formed. Various mechanisms of asymmetric collapse were proposed, yet not resulting in high enough kick velocities. We propose yet another one relying on the initial asymmetry of magnetic field of a supernova. Our estimations show that the asymmetries of magnetic field found in stars could be enough to result in asymmetric dynamics of formation of progenitor neutron star with the subsequent asymmetric diffusion and asymmetric radiation of neutrinos, reaction to momentum of which is enough to give high kick velocity to newly formed neutron star.

PHYSICAL SCIENCES

Finding Probability Distributions for Electric Field Gradient Components with Inhomogeneous Broadening in Perturbed Angular Correlation Spectroscopy

Tyler Park, Mike Adams, Austin Bunker, Jeff Hodges, Michael Stufflebeam, William Evenson, Phil Matheson

Utah Valley University

and M.O. Zacate

Northern Kentucky University

Materials contain defects, which affect crystal properties such as damping of the correlation signal $G_2(t)$ in time and broadening of the frequency spectrum in perturbed angular correlation (PAC) experiments. We attribute the inhomogeneous broadening (IHB) to the random static defects that produce a distribution of electric field gradients (EFGs). Our goal is to find a relationship between the amount of broadening and the concentration of defects. After simulating the EFGs with random configurations of defects, we map our results from the V_{zz} - V_{xx} plane to a coordinate system optimized for the EFG distribution through a Czjzek transformation and conformal mapping. From histograms in this space, we can define probability distribution functions with parameters that vary according to defect concentration. This allows us to calculate the broadened $G_2(t)$ for any concentration, and, in reverse, identify defect concentration given a broadened $G_2(t)$ spectrum.

PHYSICAL SCIENCES**Dynamics of Classical Inverted Pendulum and the Heisenberg Uncertainty Principle****Jeremy Redd and Alexander Panin***Utah Valley University*

Classical inverted pendulum can stay in the position of its unstable equilibrium (upside-down) indefinitely. However, according to the Heisenberg uncertainty principle no object can have both its position and its momentum to be absolutely certain at the same time. This fundamental principle applies to inverted pendulum resulting in an impossibility to have even an unstable equilibrium. As a consequence, an inverted pendulum has only a finite time to stay near its classical equilibrium position before it falls. Surprisingly, this time for a macroscopic-size pendulum (say, a pen on its tip) is only a few seconds long. In this presentation we analyze the time scales of “quantum mechanical instability” of inverted pendula of various lengths to see how quantum mechanics interferes with the behavior of classically macroscopic objects.

PHYSICAL SCIENCES

Fabrication and Applications of Microscale Silica Nanotubes

Jun Song

Brigham Young University

Here we report the synthesis of a patterned porous nanostructured material consisting of silica nanotubes and their application in silica based binder free thin layer chromatography (TLC) plates. The nanomaterials are formed by coating a vertically aligned and patterned carbon nanotube (CNT) forest with low-pressure chemical vapor deposition (LPCVD) of silicon. Following the infiltration process, the TLC plate is subjected to a thermal oxidation step to remove the CNTs and simultaneously convert the elemental silicon into silicon dioxide, which can be used a chromatographic sorbent.

PHYSICAL SCIENCES**Structural Studies of a Halophilic Archaeal Malate Synthase****Geoffrey Thomas, Kenneth Lamle, and Bruce Howard***Southern Utah University*

Malate synthase is one of two enzymes unique to the glyoxylate cycle, the other being isocitrate lyase. This metabolic pathway has been identified in all three domains of life; it allows plants to convert fatty acids to citric acid cycle intermediates and allows microorganisms to survive on two-carbon compounds such as acetate for a sole carbon source. The glyoxylate cycle has been shown to be important for the virulence of pathogenic organisms, such as *Mycobacterium tuberculosis* and *Candida albicans*, and is therefore a target for antibacterial and anti-fungal drug development efforts. Malate synthases found in cells of the halophilic Archaea constitute a third isoform of this important metabolic enzyme, in addition to the well-characterized A and G isoforms. They are active in 3 M salt concentrations, and they share very little sequence similarity with these other two isoforms. Database searches using basic local alignments reveal relationships between isoforms A and G but do not indicate a significant sequence relationship between members of this third isoform and those of isoform G and only a distant relationship with members of isoform A. This third isoform, which we propose to call isoform H (Halophilic archaeal), is also significantly smaller in size: ~100 residues shorter than isoform A and ~300 residues shorter than isoform G. Representatives of both isoform A and G have been structurally characterized, but no three-dimensional structural information exists for isoform H. Here we report the crystallization and preliminary X-ray diffraction from a crystal form of an H-isoform member, the malate synthase from the halophilic archaeon *Haloferax volcanii*, originally isolated from the mud of the Dead Sea. This crystal form diffracts well, and is amenable to single crystal X-ray analysis.

PHYSICAL SCIENCES

Dynamical Considerations of Relaxation Processes and Clusters of Galaxies

Brandon K. Wiggins, Anthony R. Thomas, and Brent A. Sorensen
Southern Utah University

Data from previous numerical simulations in literature maintain that the initial conditions of N-body simulations dictate the final relaxed state of a gravitationally bound system. Understanding of dynamical relaxation may continue to shed light on processes incident to non-linear structure formation. In this paper, we present the results of successive n-body simulations produced through supercomputing containing up to 20,000 particles with differing initial physical and kinematical configurations. Brief discussion is provided on computing algorithms. We compare the results of our work with literature and observation, and we discuss these processes in context of large-scale structure formation and the kinematics of cluster members. Finally, we present and discuss the results of a simple code engineered to modestly reproduce the kinematics of members of a regular, rich cluster of galaxies that has achieved a semblance of dynamical equilibrium.

POSTER SESSION**Attention to Social Categories in Infants****Jessica M. Feigleson, Joseph M. Baker, and Kerry. E Jordan***Utah State University*

Categorizing the world around us is a natural tendency. In social categorization specifically, we tend to have biases towards certain characteristics (e.g., race and gender) that we encounter. Here, we begin to explore this phenomenon by investigating the origins of human social categorization in infancy. To address this question, we are investigating whether infants are more attentive to changes in gender or changes in race when viewing a series of photographs. Preliminary results obtained with six-month-old infants suggest that, overall, they do not look any longer at changes in gender than changes in race ($p > .05$). However, a greater number of infants looked longer at a change in gender (sign-test, $p = .035$). In the future, we intend to compare six- and nine-month-old infants' performance on this task to determine if salience of these social dimensions changes over infant development.

POSTER SESSION

Investigation of the Effect of Concentration on Molecular Distribution of Cyanine Dyes in Aqueous Solution

John Kunzler, Renwu Zhang, and Hussein Samha

Southern Utah University

The molecular distribution of 5-chloro-2-[3-[5-chloro-3-(4-sulfobutyl)-2(3H)-benzothiazolylidene]-1-propenyl]-3-(4-sulfobutyl)-benzothiazolium hydroxide triethylamine dye, (NK-3796) in aqueous solution is investigated using absorption and emission spectroscopy.

The equilibrium, $n(\text{monomer}) \rightleftharpoons \frac{1}{2}n(\text{dimer}) \rightleftharpoons (\text{H-aggregate})_n$, is observed over a series of concentrations ranging from 10^{-4} mM to 0.1 mM. At concentration $<10^{-6}$ M, the solution contains mainly monomeric dye. Dimer becomes more significant when the concentration of the dye exceeds 10^{-5} M. Unlike the substituted dye at the 9th position, this dye tends to form H-aggregate at higher concentration ($>10^{-4}$ M). Monomers and dimers exhibit strong emission when excited at 450 nm. However, the emission of the H-aggregate is very weak due to self quenching.

SOCIAL SCIENCES**Harm Reduction in Higher Education in the U.S.:
Preparing Policy-makers and Human Service
Providers****Mark O. Bigler***Weber State University*

Higher education in the U.S. is one important training ground for future policy-makers and health and social welfare practitioners. Harm reduction is an emerging policy, prevention, and practice model that has gained a great deal of attention in recent years. While harm reduction is intuitive to many policy-makers and practitioners and is now being adopted in many parts of the world, helping professionals in the U.S.—and those who train them—have been slow to endorse the model. This paper describes results of a study that examined the integration of harm reduction into the curricula of two distinct disciplines in the U.S.—social work and health professions. Participants were students of social work (n=855 bachelor's, n=461 master's) and health professions (n=160) who completed a 24-item questionnaire that assessed harm reduction thinking, endorsement of harm reduction strategies, formal exposure to the harm reduction model, harm reduction ideology, and demographics relevant to the study. Just over one third of respondents (34.1%) reported specific instruction in harm reduction. Significant findings are discussed, including those based on comparisons between undergraduate and graduate social work students and comparisons between students in social work versus health professions majors. Findings are considered in the context of professional preparation in health and human services. Social, health, and public policy implications are discussed.

SOCIAL SCIENCES

Clever Coyotes: An Investigation of Numerical Discrimination Abilities of Coyotes (*Canis latrans*)

Joseph M. Baker, Katrina S. Rodzon, John Shivik, and Kerry E. Jordan

Utah State University

Previous studies have demonstrated that various nonhuman species such as monkeys and birds exhibit numerical abilities, which conform to predictions of Weber's Law in that successful discrimination is mediated by the ratio between opposing numerical options. Here, we tested the ability of semi free-ranging coyotes at the United States Department of Agriculture–Utah State University Predator Research Facility to discriminate between large and small quantities of discrete food items and found that coyotes reliably discriminate between large versus small quantities of such food. As predicted, this discrimination is mediated by Weber's Law; when the ratio between options increases, the tendency of the animals to choose the larger option also increases. Moreover, coyotes were not basing their judgments on olfactory cues alone. Our results are the first to identify quantitative competency in coyotes and suggest that coyotes rely on this competency when choosing food options. These results may inform coyote livestock predation prevention methods.

SOCIAL SCIENCES**The Economics of Geographical Ward Boundaries
in the LDS Church****Tyler Bowles and Daniel Robertson***Utah State University*

Just a few years ago, Michael McBride published his intriguing article “Club Mormon: Free-Riders, Monitoring and Exclusion in the LDS Church,” highlighting important incentives at work in the organization of the Church. In his discussion of the Church’s efforts to monitor its members, McBride mentions, almost in passing, that the Church uses geographical ward boundaries to maintain small ward sizes since smaller congregations require fewer monitoring costs. In this paper, we argue that the Church uses geographical boundaries not only to control ward size, but also to stimulate the creation of religious capital. Ward boundaries do this by stabilizing the ratio of high-contributing to low-contributing members in a ward. This results in each ward collectively having a type of “property right” over those within their boundaries. These aspects of ward boundaries increase the efficiency of religious capital production. We hypothesize that the benefits of thus restricting members’ choice of ward outweigh the associated costs.

SOCIAL SCIENCES

The Triangle of Political Communication: How Infotainment Has Changed the Relationship between the Media, Public, and Politicians

Julia Fullmer

Southern Utah University

This paper explores the relationship between politicians, traditional media, and the public and the extent to which the emergence of infotainment has shifted the relationship. Current research indicates the traditional triangle relationship between the media, public, and politicians has shifted with the emergence of non-traditional media such as infotainment, or rather the attempt of media to treat factual material in an entertaining manner. The indirect effects that stem from the relationship shift reflect the cumulative and complementary function of mass communication in response to changing media consumption habits. An analysis of nontraditional media in coordination with the triangular political communication relationship reveals a fourth actor in the process. Infotainment has forced the political communication relationship to evolve as the public seeks nontraditional outlets to gather pertinent information.

SOCIAL SCIENCES

Outlaw Motorcycle Gang Culture

John Hill

Salt Lake Community College

An analysis of the culture of outlaw motorcycle gangs in America. The author covers the origins, organization, symbolism, and lifestyles of these gangs. Also addressed is the impact of these gangs on the criminal justice system and some considerations for the public.

SOCIAL SCIENCES**Determinants of Racial Concentration in United States Counties, 2000****L. Dwight Israelsen***Utah State University*

Studies of residential segregation have concentrated on racial/ethnic segregation in neighborhoods, metropolitan statistical areas, counties, and states and have looked at socioeconomic status and other variables to explain differences in segregation measures across groups and over time. Commonly used segregation indices measure segregation of a particular race or ancestral group in an area by examining the distribution of that group across sub-areas. The current study introduces a new measure of segregation, the "racial concentration ratio" or RCR. The RCR is a one-parameter measure of the racial (ethnic, ancestral) composition of an area (county, state) relative to the racial composition of the entire United States, and is similar to a Gini coefficient. RCRs are based on the percentages of county (state) population in six groups: Non-Hispanic Whites, Hispanics, Blacks, Asians (Asians/Pacific Islanders), American Indians (Indians and Alaskan Natives), and All Other. First, the percentage of each group in a county or state is scaled by the overall U.S. percentage of that group. Then, RCRs are calculated treating these cumulative scaled percentages as "cumulative income" is treated in the income Gini coefficient calculation (i.e., on the y axis of the Lorenz curve) and treating the fractions 1/6, 2/6, 3/6, 4/6, 5/6, and 6/6 as "cumulative population" is treated in the income Gini coefficient calculation (i.e., on the x axis of the Lorenz curve). Hence, if the racial composition of an area is exactly like that of the entire U.S., the RCR is zero, and as the racial composition increasingly diverges from that of the U.S., the RCR grows closer to one. These RCRs are calculated for all U.S. counties and states. In addition, RCRs are calculated for each county in a particular state, where the percentage of each racial/ethnic group is scaled by the percentage of that group in the particular state. Using the two sets of county RCRs as dependent variables, econometric models including economic, social, education, demographic, and political independent variables are developed and

used to identify the determinants of RCRs at the county level. For the model using RCRs scaled to the U.S. population, we find that statistically significant variables associated with higher county RCRs include net in-migration of Hispanics, net in-migration of "Others," net births of Blacks, net births of Hispanics, net births of Others, percent speaking a language other than English at home, percent rural farm dwellers, average age, poverty rate, unemployment rate, local government employment per capita, average household size, percent of eligible voters who voted, and percent of voters who voted Democrat. Statistically significant variables associated with lower county RCRs include population churning rate, percent foreign-born, percent urban dwellers, and percent with at least 12 years of schooling. For the model using RCRs scaled to the populations of the respective states, we find that statistically significant variables associated with higher county RCRs include net in-migration of Hispanics, net births of Whites, net births of Hispanics, net births of Others, percent rural farm dwellers, poverty rate, unemployment rate, local government employment per capita, percent of households married, crimes per 100,000, and percent of eligible voters voting. Statistically significant variables associated with lower county RCRs include net in-migration of Blacks, net births of Blacks, percent foreign-born, percent urban dwellers, population per square mile, real per capita income, and percent with at least 12 years of schooling.

SOCIAL SCIENCES

Much Ado About Nothing: A Virgin's Perspective on Sexual Activity

CoCo James, Andrea Santurro, and Spencer Blake

Salt Lake Community College

In 2009, a survey was given at Salt Lake Community College. This survey was a replication of a study previously given at Truckee Meadows Community College (TMCC) in 1988. It surveyed attitudes on first sexual experience of sexual intercourse. Because of the sensitive nature of the survey, accommodations were made to facilitate student anonymity. To avoid sampling only those who would be willing to indicate that they have had sex by participating in the survey, a section was created for those who had not yet participated in sexual intercourse. This section was not in the original TMCC survey. This work is related to the responses that the additional section created. The survey showed the reasons students gave for not participating in sexual intercourse. It also showed that just because that hadn't participated in intercourse that didn't mean they were sexually inactive.

SOCIAL SCIENCES

On Legalization of Compensated Solid Organ Donation and Establishment of Organ Banks to Govern Organ Procurement and Distribution

Ruhul Kuddus

Utah Valley University

Current laws and regulations allow donation of solid organs only as an act of charity but allow compensated donation of plasma and sperm. A highly efficient network of plasma centers, sperm bank affiliates, and organ procurement centers harvests and coordinates the distribution of the specimens. There is no critical shortage of plasma and sperm, and the collection centers are able to obtain high-quality samples from a restricted pool of healthy donors. On the other hand, lack of an adequate supply of donated organs is the most critical problem of transplantation medicine. Over 100,000 patients (mostly patients with kidney failure) are currently waiting for an organ in the United States alone, and many of those patients will die while in the waiting list. Although organ donors receive no compensation for their “gifts of life,” the donated organs generate a significant economic output. The parties that enjoy the economic pot are generally reluctant in changing the current system. The crisis of organ shortage forces harvest of organs from suboptimal donors (i.e., donors with genetic diseases such as Down syndrome, older donors, and organs that have suffered significant ischemia) and obtaining organs using illegal means (such as international organ and human trafficking). A healthy person may donate bone marrow, a kidney, or portion of the liver with an acceptable level of health risks. Legalizing compensated donation of solid organs through establishing organ banks could end the current crisis of solid organ shortage. The organ banks with an appropriate legal and ethical foundation and enforcing authority could use the already existing solid organ procurement and distribution network to harvest high quality of organs, save lives by distributing the organs across the regional boundaries, and inhibit any type of questionable organ procurement activities. The present

article argues for legalization of compensated solid organ donation and establishment of organ banks and outlines the structure of such banks.

SOCIAL SCIENCES

Americanization of Russian Culture and its Effects on English Language Acquisition in that Country

Olga A. Pilkington

Dixie State College

This paper examines linguistic and cultural changes that took place in post-Soviet Russia and analyzes them in relation to the acquisition of English as a foreign language in that country. The research reveals the link between Americanization of Russian culture and English language learning. According to the data collected for this project, Americanization of Russian culture has a positive effect on English language acquisition. The findings demonstrate that exposure to culture alone (not supplemented by formal instruction) is sufficient to acquire some English language vocabulary. The effect of Americanization is not generation specific and influences older and younger members of the society alike.

SOCIAL SCIENCES

Cognition and Impulsivity: The role of attention

Katrina Rodzon, Amy Odum, and Kerry Jordan

Utah State University

Impulsivity, or the tendency to engage in behavior without sufficiently considering the consequences of this behavior, is often measured using delay discounting tasks and a hyperbolic discounting model. Recent research has started to evaluate the impact of cognitive factors on impulsivity, finding that taxing working memory significantly increases impulsivity. Our studies aimed to evaluate whether working memory uniquely impacts delay discounting or whether other cognitive factors, such as attention, exert a similar influence. Study 1 replicates the findings of Hinson and colleagues in 2003, while Study 2 evaluates the effects of limiting attentional capacity and allocation on impulsivity. Attentional taxation significantly increases impulsivity as measured by delay discounting. This effect of attention is not significantly different from the effect of taxed working memory on delay discounting, suggesting that working memory may not enjoy a privileged cognitive influence on delay discounting.

SOCIAL SCIENCES**Enumeration and Temporal Perception****Danielle Schwarz, Rhett Bolton, Katrina Rodzon, and Kerry Jordan***Utah State University*

It has been shown that cognitive representation of abstract and concrete environmental properties can be seen across species with humans, rats, and pigeons being able to quantify stimuli based on number, time, and space. More recent research has investigated the link between the systems demonstrating that both number and distance impact temporal processing. We further investigated this link by utilizing numerical stimuli presented simultaneously rather than serially to see if the impact of number on time was still present. In addition, the reverse relationship was investigated to see if time influenced enumeration of neutral stimuli. Preliminary results replicate the influence of enumeration on temporal perception as well as demonstrating no effect of time on number.

SOCIAL SCIENCES**Reassessing American Foreign Policy Amidst the Maelstrom: The Last Superpower? Revisiting the Paradigm of Imperial Decline****G. Michael Stathis***Southern Utah University*

The economic and political maelstroms of the past few years have not only brought into question the status of the United States as a superpower but have raised questions about the very nature of what we have called a superpower. While there is still much to admire in the United States as a great power, one might be led to ask whether it is the last superpower. Once again Paul Kennedy's paradigm of overextension, or imperial overstretch and decline, a paradigm of imperial decline if you will, has come into focus, and again we turn to Samuel P. Huntington's more optimistic response to ponder the potential fate of the empire of liberty. And should the United States fall victim to Kennedy's theory of imperial demise, will another superpower emerge? Or have we reached a point when the necessary elements of superpower status have proven too taxing for even the most innovative of powers? Huntington postulated that unlike other great powers that have come and gone, the United States has had that rare ability to "renew" its power and itself and that outcome is likely to hold true at least one more time due in some part to the audacity of hope reflected in the new American president. But beyond that the realities of the new century will almost certainly prove too overwhelming to allow the birth of any new superpowers. Two other questions have emerged to further complicate this issue: Should the paradigm of imperial decline prove sound will it lean towards the traditional notion of gradual decline and fall, or as Niall Ferguson has recently postulated will it come quickly as a "thief in the night," and secondly, as teachers and scholars, how do we react academically to the paradigm of decline in the shadow of the recent maelstrom?

Clearly the paradigm of imperial decline remains a relevant topic, and history seems to have favored the process of gradual decline rather than

a precipitous and quick fall. Interestingly, as a recent contributor to the literature of imperial decline has noted, we have the enviable advantage of historical perspective, and that should form the better part of motivation for academics regarding this vital issue.

SOCIAL SCIENCES

Water Policy-Making and the Palestinians

Julia S. Templin

Utah State University

The politics of water as a theme of the conflicts in the Middle East has gained momentum over the past few decades, and particularly in recent years. In the Palestinian–Israeli conflict, it is taking an especially prominent role. This study looks at the Palestinian involvement in the regional water discussion and policy-making through four periods of Palestinian modern history: the British Mandate, the Jordanian Administration, the Israeli Occupation, and the Palestinian Authority. The water issue is closely linked with the mission of establishing a Palestinian state. The surrounding nations vied for water resources in their process of state-building. However, the Palestinians remained without any water resources or leadership to contend for them through most of the 20th century. Despite the importance of water resources for the future of a Palestinian state, Palestinians have largely been left out of regional water policy-making.