

THE MAGAZINE FOR CONSUMER ELECTRONICS SERVICING PROFESSIONALS

ELECTRONICTM

Servicing & Technology

DECEMBER 1989/\$3.00

Troubleshooting Varactor Tuners — Part II

Servicing Zenith Microcomputers — Part V



Looking for
parts?
Here's
help

AN INTERTEC PUBLICATION

Cut Your Video Troubleshooting Time By 54%* With The VA62A Universal NTSC Video Analyzing System

**New
And Improved!**



VA62A Universal Video Analyzer
Patented

- Identify tuner problems with All-Channel, VHF, UHF, and Cable RF Generators.
- Pinpoint IF Problems with modulated troubleshooting signal and exclusive programmable IF/RF generators.
- Isolate any video problems with patented video and standard color-bar patterns.
- Find defective stages, without disconnecting parts, using exclusive phase-locked drive signals.
- Test yokes and flybacks, plus measure signal levels with autoranged digital meter.

* Based on a nationwide survey of users who reported an average time savings of 54% compared to their previous test equipment.

Call 1-800-SENCORE
In Canada 1-800-851-8866
(736-2673)

Update For New Technology With Exclusive Phase-Locked Accessories

VC63 VCR Test Accessory

Solve the VCR servicing challenge with substitute VCR signals, phase-locked to your VA62A.



NT64 NTSC Pattern Generator

Meet all Warranty Requirements by adding the NTSC full-field and split-field patterns to your VA62A Universal Video Analyzer.



ST65 Video Analyzer Stereo TV Adder

Easily test and troubleshoot today's new MTS Stereo TVs & VCRs.



RG67 NTSC Video Monitor Adaptor

Expand into analog and digital video monitor service with phase-locked R, G, B and I signals.



SENCORE



PHILIPS

THERE IS NO SMARTER CHOICE THAN PHILIPS ECG.



ECG PR200A OR PR60: FOR THE RIGHT ANSWER TO YOUR SCOPE PROBE NEEDS.

ECG™ scope probes come packed with features and packed with value. Features on the PR200A include:

- 200 Mhz bandwidth capability
- X1, X10 attenuation and reference switch
- Low input capacitance
- Large thumb switch with positive detents, for easy switching between X1 and X10 and ground reference
- Comes with an IC tip, BNC adaptor, insulating tip and a retractable hook



The PR60 features:

- 60 Mhz bandwidth capability
- X1, X10 attenuation and reference switch
- Retractable hook

ECG scope probes: the smart choice.

Circle (4) on Reply Card

ECG VCR MECHANICAL REPLACEMENT PARTS CATALOG: THE SMART PLACE TO LOOK FOR YOUR REPLACEMENT PARTS.

The ECG VCR mechanical replacement parts catalog has the industry's most comprehensive cross-references to make sure you get the correct part:

- Complete product line includes: 13 pinch rollers, 42 idler wheels and assemblies, 4 idler tires and 48 belt kits
- 55 individual belts also available

ECG VCR replacement parts: the smart choice.



Circle (5) on Reply Card

Contact one of more than 900 distributors or call 1-800-233-8767 for the name of the distributor nearest you. It just might be the smartest call you make all week.

ECG DM-26 AND DM-27 FULL FUNCTION GENERAL PURPOSE MULTIMETERS.

The ECG DM-26 and DM-27 multimeters are loaded with features and loaded with value. Just check out the array of capabilities:

- Diode test
- Rotary range switch
- Tilt stand
- 0.8% basic DC accuracy
- 3½" digit LCD display, 0.5" high
- 20 MΩ full scale
- 10 MΩ input resistance, DC
- Low power Ohms
- Overload protected
- The DM-27 also includes an audible continuity test



ECG multimeters: the smart choice.

Circle (6) on Reply Card

ECG TV-1100 CABLE CONVERTER: THE SMART WAY TO MAKE ANY TV CABLE-READY.



The ECG TV-1100 Cable Converter adapts any TV to receive cable channels. And the added features give added value:

- Remote control features on/off, channel selection, and picture fine tuning. Operates from up to 25 feet away
- Converts VHF and cable channels to a switch-selectable output, channel 2 or 3
- Remote control features last channel recall and memory to store up to 10 favorite channels
- Features a sleep timer that automatically turns TV off after pre-determined time (up to 90 minutes)

ECG cable converter: the smart choice.

Circle (7) on Reply Card

Philips ECG Company

A Division of North American Philips Corporation

© 1989, Philips ECG Company.



Page 8

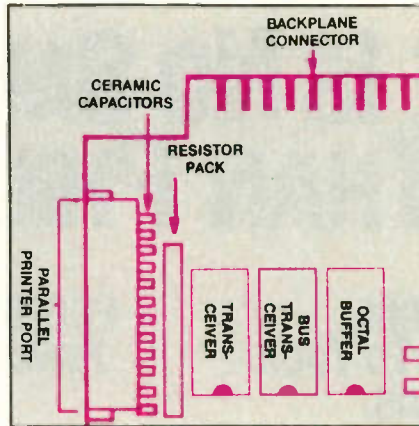

Page 20

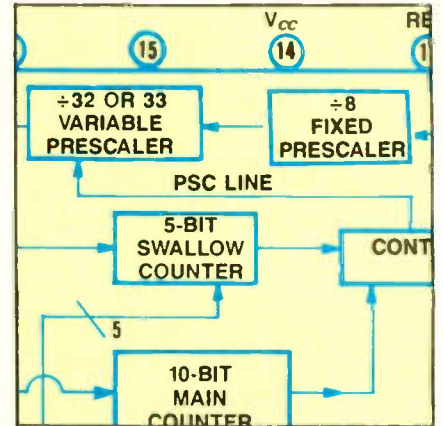

Page 38

FEATURES

8 Looking for Parts Information? Here's Help

By Conrad Persson

The top problem for most electronics servicers is the difficulty they face getting replacement parts and schematics. The problem: One manufacturer makes the product, but the name on the front of the TV might be some off brand you've never heard of. Next time you're faced with this problem, try to find a UL or FCC number. With that information, you might have a shortcut to the manufacturer's order line.

20 Servicing Zenith Microcomputers Part V: Timing Signals

By John A. Ross

One of the most important uses for the microcomputer is the storage of important information. However, without proper timing signals, the microcomputer can't access that memory, and that can spell big trouble for customers who rely on their computers' memory. Here's a

run-down of how the microcomputer's timing signals function and how to keep them operating properly.

38 Troubleshooting Varactor Tuners — Part II

By Stephen J. Miller

A faulty PLL tuning system can seem a little daunting, but there is a logical line of attack you can take to track down the problem. Part II of this series describes the PLL tuning system and offers some basic troubleshooting steps to follow in repairing this common system.

DEPARTMENTS

4 Editorial
Records and Identification

6 News

16 Books

18 Troubleshooting Tips

19 Test Your Electronics Knowledge

27 Profax

37 Technology
The Computerized Library

48 Products

50 What Do You Know About Electronics?
Truth Tables

52 Audio Corner
Electronically Tuned Radios

54 Video Corner
Understanding the Vacuum Fluorescent Display — Part III

56 Computer Corner
Print-head Problems

57 Literature

58 Business Corner
Collecting Those Bouncing Checks

59 Readers' Exchange

60 Advertisers' Index

ON THE COVER

The tough part of repairing consumer electronics products should be the actual troubleshooting process. However, after tracking down the faulty component, the electronics servicer often spends more time tracking down a source for the replacement. Finding replacement parts and schematics can be the most frustrating part of the servicer's job. (Photo courtesy of Thomson Consumer Electronics.)

THE MAGAZINE FOR CONSUMER ELECTRONICS SERVICING PROFESSIONALS

ELECTRONIC
Servicing & Technology

LEADER

A TYPICAL "PORTABLE" SCOPE

THE TRULY PORTABLE
LBO-315

If both of these scopes are portable,
then this is a lapdog.

What's the difference between a portable scope and the *truly* portable LBO-315? A lot of weight, among other things. At just 10 lbs and 10.5 x 3 x 13" with battery, the full-function LBO-315 can easily go everywhere a technician goes.

Don't waste money.

When a tech must return to the shop or a car, for the heavy scope left behind, time costs money. LBO-315, the scope techs love to carry, saves time and *delivers more profit*. It's that simple.

No so-called "portable" even comes close.

Compact 60-MHz LBO-315 packs all the performance of a bench scope. Operates from

supplied 12-Vdc battery, external 10 to 20 Vdc source or 85 to 264 Vac, without switching. Has bright 3.5", 12-kV, PDA CRT; alternate trigger, time base, and sweep; 2-channel and X-Y operation; variable holdoff, and more. *All this from a unit small enough to fit into an attache case!*

Leader has "truly portable" 20 to 60-MHz oscilloscopes for ac/dc or ac operation. Each is backed by our 2-year warranty and factory service on both coasts.

Call toll-free
1 800 645-5104
In NY State
516 231-6900

Ask for our full-line Catalog, an evaluation unit, and the address of your nearest Leader Distributor.

For Information Circle (8) on Reply Card

For Demonstration Circle (9) on Reply Card

Leader Instruments Corporation
380 Oser Avenue, Hauppauge, New York 11788
Regional Offices:
Chicago, Dallas, Los Angeles, Boston, Atlanta
In Canada call Omnitrax Ltd. 416 828-6221

LEADER
FOR PROFESSIONALS WHO KNOW
THE DIFFERENCE

The truly portable LBO-315 comes with complete accessories, as shown at left.



Records and identification

One of the fascinating things about the old *Dragnet* show, for those of us who remember it, was when Joe Friday would be faced with a crime and would tell his sidekick to "run it through R&I." For those of you who are unfamiliar with that term, R&I is Records and Identification. The next scene we'd see was in the records room, with IBM cards whizzing through the sorter. Ultimately, there would be a match or several matches for the detectives to investigate.

Wouldn't it be nice if servicers had a similar setup for identifying electronics manufacturers? Electronics servicers today face a problem similar to the problems Joe Friday faced. For example, Friday had to go into the police records with whatever information he had — a fingerprint, an MO (modus operandi or method of operation) — and, from that information, he had to identify the perpetrator. The servicer's situation is similar — to obtain servicing literature or parts, he frequently has to identify the manufacturer of a TV, VCR or other product from some sketchy information: an obscure brand name, a UL manufacturer's code number, an FCC ID number.

Once he has identified the manufacturer, he has to try to find a source for the literature or parts locally or through mail order. As every servicer knows, just because you have found a source for something, it doesn't mean it's going to be easy to get in contact with the company. Many distributors are so busy it's almost impossible to get through to order what you need. It might be necessary to try several sources to find one that's responsive enough to give you the help you need. Unfortunately, all of this effort takes time — time away from the bench or from running the business.

It's bad enough if you only have to do it once for a given manufacturer, but if weeks later another one of those units from that manufacturer comes in and you've forgotten everything about it, you'll have to waste time all over again.

Every servicing facility needs an "R&I division" so the effort you expend in

researching a product isn't wasted. Every precious gem of information you unearth should be filed so the next time you need that information, it's available.

But the key word is "file." It's not enough just to retain the information somewhere. If the information is going to be useful, you have to store it somewhere where you can find it readily, not in a stack of papers somewhere. Of course, it takes time to file things properly, but the time saved later will compensate for the time it takes to file the information properly.

Taking another clue from Joe Friday, it might make sense to hire someone to perform this task. Joe didn't file or retrieve the information himself. The department had an R&I division to do the work. For the busy technician, it might make sense to hire a records clerk, even if only part-time, to set up a filing system and maintain it. Another possibility for those with a personal computer in the shop is to use a computer database program or even a good word processor or spread sheet program to file this information and make it easy to retrieve.

This issue gives you what we hope is a good start on establishing or expanding your filing system. The article "Looking for Parts Information? Here's Help" features not only a listing of some suggested sources of information, but partial cross-references from UL manufacturer code number to manufacturer name, and from FCC ID number to manufacturer name. Because these are only preliminary and unofficial, we can't guarantee that all of the information in these cross-references is correct, but it's a good start. Don't forget to file the information now so you can find it later when you need it.

An information file won't solve all of the problems that face electronic servicers today, but it will go a long way toward saving time that might otherwise be wasted in duplicating research efforts.

Nile Conrad Pearson

NTE KEEPS YOU UP AND RUNNING.

NTE specializes in "replacitivity," the science of getting things up and running again—fast! After all, downtime is costly, so no one can wait weeks on end for an OEM part to come in. With NTE, no one has to! One call gives you access to 3,400 top of the line universal replacement semiconductors that are cross-referenced to more than 235,000 original devices! Included in the NTE line are: bipolar transistors, integrated circuits, rectifiers, diodes, thyristors, optoelectronic devices, varistors, resistors, capacitors, and much, much more. All are backed by NTE's exclusive two-year warranty.

For your copy of the NTE Technical Guide contact your local NTE distributor, or simply fill in the coupon below and send it to us today with a check or money order for \$3.25 each.

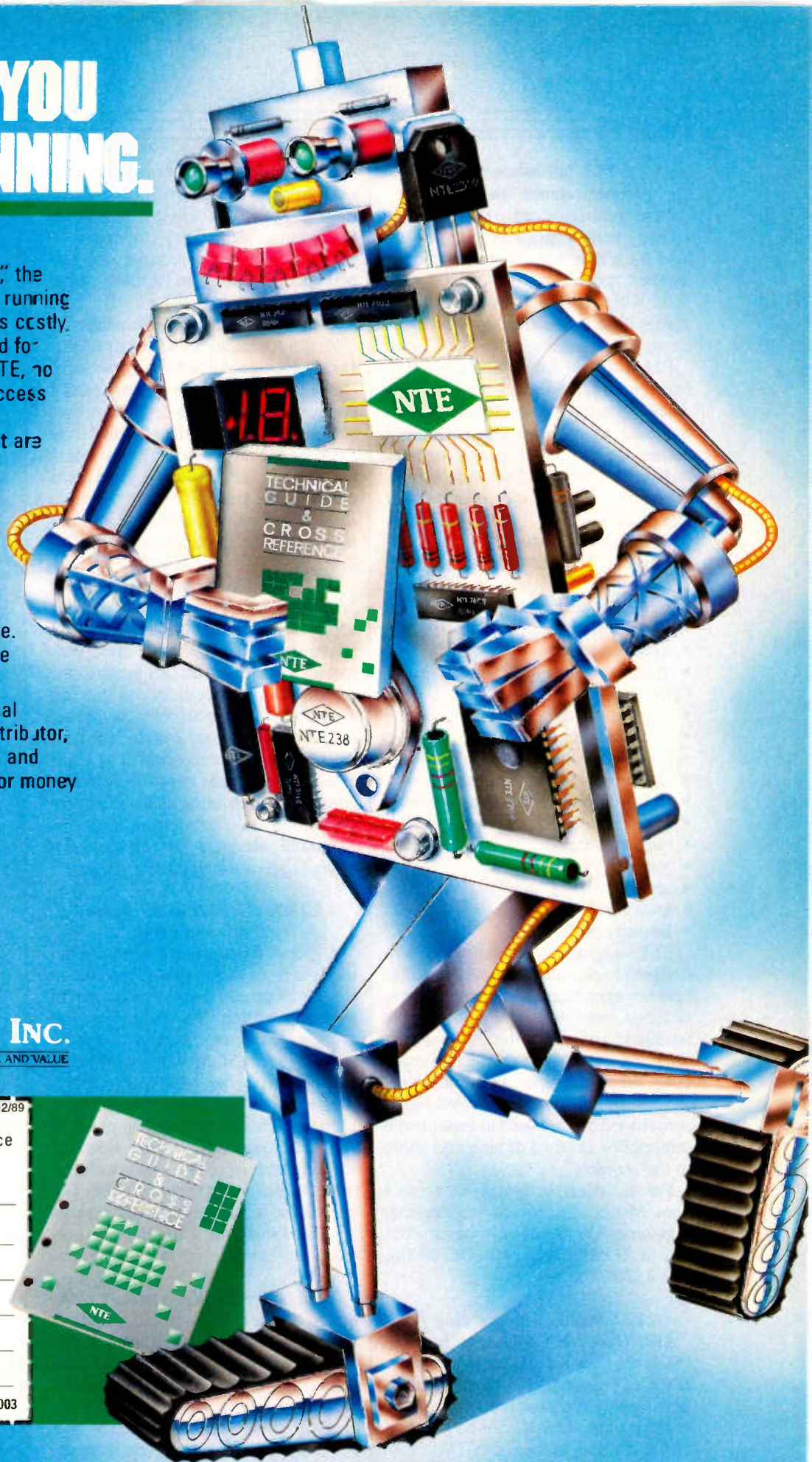

NTE ELECTRONICS, INC.

A WORLDWIDE REPUTATION FOR QUALITY, SERVICE AND VALUE

Please rush me _____ copies of the ES&T 12/89
NTE Technical Guide and Cross Reference
manual at \$3.25 each. I have enclosed
my check or money order for a
total of \$ _____

Name _____

Company _____

Address _____

City _____

State _____ Zip _____

Mail to: NTE, 44 Farrand St., Bloomfield, NJ 07003

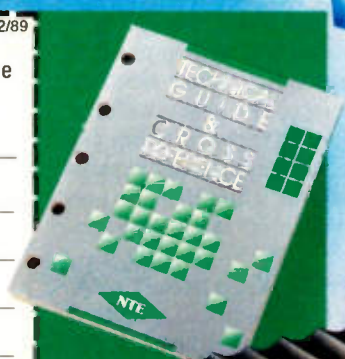

FOR THE NAME OF YOUR NEAREST NTE DISTRIBUTOR, CALL NTE TOLL FREE: OUTSIDE NJ 1-800-631-1250 • INSIDE NJ 1-800-624-2624

Circle (10) on Reply Card

EIA publishes CD measurement standard

New guidelines for testing performance characteristics of CD players have been issued by the Electronic Industries Association (EIA). The standard will provide a uniform rating system for consumers to use when purchasing CD players.

EIA Standard 560, which was developed by the CD Subcommittee of EIA's Audio Systems Committee, applies to domestic reproducing equipment and defines the method of measurement as well as the form of disclosure of performance characteristics of consumer CD players.

The standard lists 15 primary disclosures to be used when rating CD players:

- frequency response.
- signal-to-noise (S/N) ratio.
- dynamic range.
- total harmonic distortion + noise (THD-N).
- channel separation.
- de-emphasis error.
- wow and flutter.
- intermodulation distortion.
- phase difference between channels.
- level difference between channels.
- output voltage.
- pitch error.
- access time.
- level linearity.
- linearity with dither.

EIA engineering standards are designed to eliminate misunderstandings between manufacturers and purchasers, facilitate interchangeability, improve products, and assist the purchaser in selecting and obtaining, with minimum delay, the proper product. The standards are issued on the basis of voluntary compliance and are used to disseminate information deemed of technical value to the industry.

For technical information, contact Tom Mock, director of engineering, Consumer Electronics Group, at 2001 Eye St. N.W., Washington, DC 20006; 202-457-4975.

ITT builds decoder chip

The National Captioning Institute (NCI) has awarded a \$1 million contract to the ITT Corporation for the design, development and production of a single decoder chip. This IC can be installed during the manufacturing of TVs, cable converters and VCRs. NCI says TV

manufacturers will be able to offer sets capable of decoding closed captions by the mid 1990s. ITT will use large-scale integration technology to make a decoder chip with a reduced size and power consumption and a lower price.

Zenith sells computer business

Zenith Electronics and Groupe Bull, Paris, have signed a definitive agreement in which Bull will purchase Zenith's computer business (the Zenith Computer Group, which includes Zenith Data Systems and Heath/Zenith). The transaction will allow Zenith to grow in its original core business, consumer electronics, and will allow Bull to improve its position in the microcomputer industry.

Zenith has elected to submit the proposed transaction to its stockholders for approval. The transaction also is subject to regulatory approval and other customary conditions. Zenith plans to repay short-term obligations and to retire a portion of long-term debt. According to Jerry K. Pearlman, Zenith chairman, "The remaining proceeds will be available for appropriate investments in new consumer electronics and component technologies, particularly high-definition television (HDTV) and advanced high-resolution color displays."

EIA/CEG establishes home automation group

A special focus group comprising executives from 14 companies involved in the development and introduction of home automation (HA) technology and products convened in July to discuss plans for successfully introducing home automation to the consumer market. The purpose of the group is to exchange ideas and information to help promote HA technology to consumer electronics manufacturers. The group will also try to influence future public policy and build inter-industry marketing support programs that will align with the participating companies' marketing objectives.

The EIA/CEG has also been involved in developing HA standards. According to the association, marketing strategies should include stressing the benefits of HA technology, which include enhanced security and personal entertainment; increased convenience, efficiency and economy in home energy and management; and better quality of life. ■

Electronic Servicing & Technology is edited for servicing professionals who service consumer electronics equipment. This includes service technicians, field service personnel and avid servicing enthusiasts who repair and maintain audio, video, computer and other consumer electronics equipment.

EDITORIAL

Nils Conrad Persson, *Editor*
Tom Cook, *Senior Managing Editor*
Alisa Carter, *Associate Editor*
Jennifer Hinkle, *Editorial Assistant*

CONSULTING EDITORS

Carl Babcock, *Consumer Servicing Consultant*
Homer L. Davidson, *TV Servicing Consultant*
Christopher H. Fenton, *Circuit Fabrication Consultant*
William J. Lynott, *Business Consultant*
Victor Meeldijk, *Components Consultant*
Kirk G. Vistain, *Audio Consultant*
Sam Wilson, *Electronics Theory Consultant*

ART

Barbara Miles, *Graphic Designer*

BUSINESS

Cameron Bishop, *Group Vice President*
Eric Jacobson, *Group Publisher*
Greg Garrison, *Sales Manager*
Kevin Callahan, *Creative Director*
Marcia Durrett, *Marketing Director*
Evelyn Hornaday, *Promotions Manager*
Darren Sextro, *Promotions Coordinator*
Dee Unger, *Advertising Business Manager*
Susan Edwards, *Advertising Coordinator*

ADVERTISING

Greg Garrison, 913-888-4664

ADMINISTRATION

R. J. Hancock, *President*
Chuck Rash, *Corporate Circulation Director*
Sandra Stewart, *Circulation Director*
Donna Schlagle, *Circulation Manager*
Customer Service, 913-541-6628



The Audit Bureau

Member, Audit Bureau of Circulation



Member, American Business Press



Member, Electronic Servicing Dealers Association

CORRESPONDENCE

Editorial and advertising: P.O. Box 12901, Overland Park, KS 66212 (a suburb of Kansas City, MO); 913-888-4664. Circulation: P.O. Box 12960, Overland Park, KS 66212. Home office fax: 913-541-6697. Home office telex: 42-4156 INTERTEC OLPK

SUBSCRIPTION PRICES: one year, \$19.49; two years, \$32.98 in the USA and its possessions. Foreign countries: one year, \$23.49; two years, \$36.98. Single copy price: \$3.00; back copies, \$5.00. Adjustment necessitated by subscription termination to single copy rate. Allow 6 to 8 weeks for new subscriptions.

PHOTOCOPY RIGHTS: Permission to photocopy for internal or personal use is granted by Intertec Publishing Corp. for libraries and others registered with Copyright Clearance Center (CCC), provided the base fee of \$2 per copy of article is paid directly to CCC, 21 Congress St., Salem, MA 01970. Special requests should be addressed to Eric Jacobson, publisher.

ISSN 0278-9922 \$2.00 + 0.00

Electronic Servicing & Technology (ISSN 0278-9922) is published monthly for \$19.49 per year by Intertec Publishing Corp., 9221 Quivira Road, Overland Park, KS 66215. Second-class postage paid at Shawnee Mission, KS and additional mailing offices. POSTMASTER: Send address changes to ELECTRONIC SERVICING & TECHNOLOGY, P.O. Box 12960, Overland Park, KS 66212.

©1989 by Intertec Publishing. All rights reserved.



EVERY SONY PRODUCT COMES FULLY EQUIPPED WITH OUR DEDICATION TO QUALITY SERVICE.

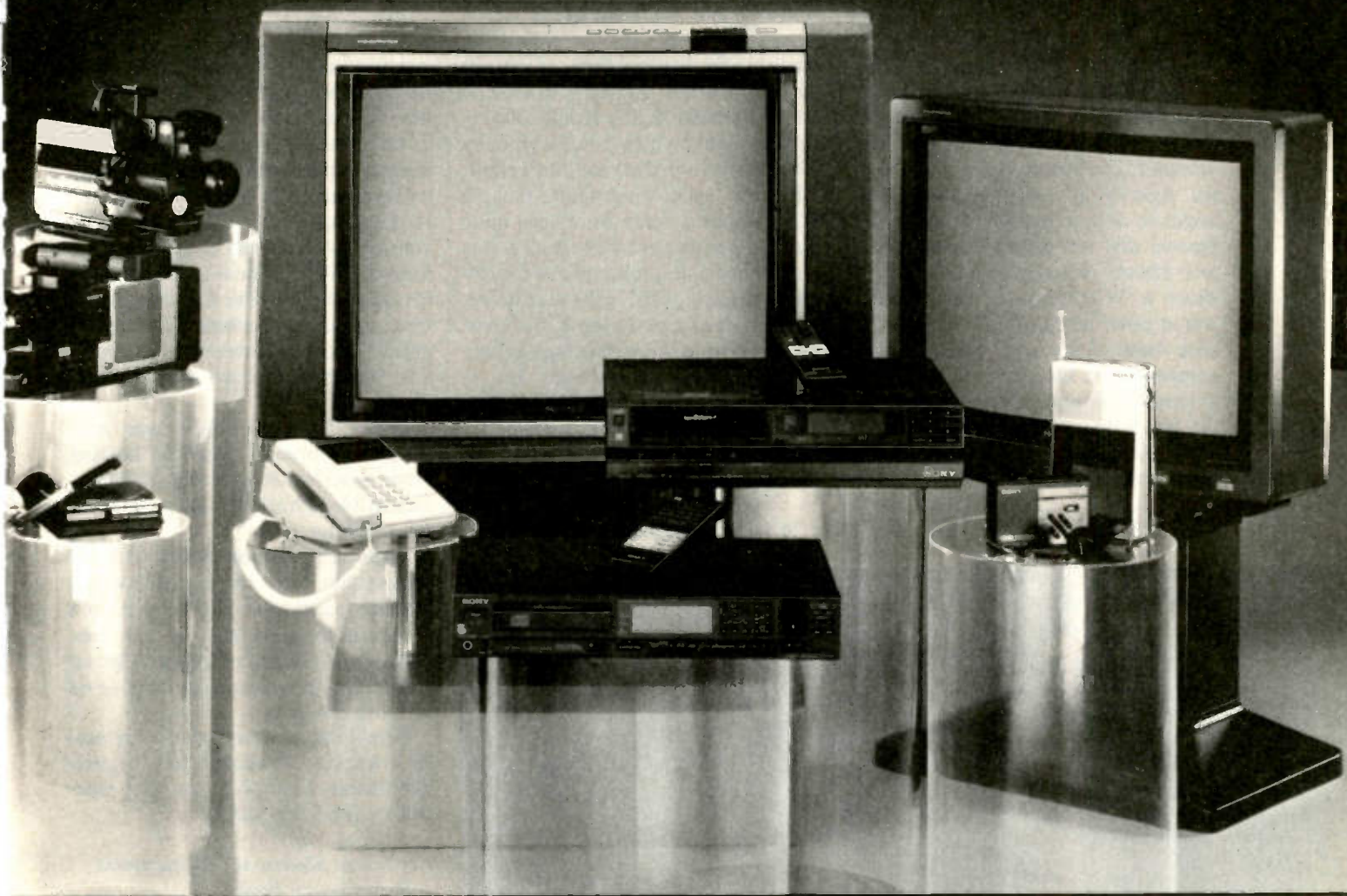

Your customers may never need The Sony Service Company, but it's comforting to know we're only a phone call away.

Our nationwide network of Sony Service Centers, Training and Technical Departments and our National Parts Center represent our commitment to service. This means if you sell or service Sony products, Sony is there for you. Read on to find out more.

1. Sony Service Centers. Repair work is performed at over 27 Sony Service Centers located throughout the country (even Hawaii). The Centers also sell Sony accessories and rent video equipment. For the nearest Sony Service Center call (201) 930-SONY (7669).

2. Regional Centers. Our Regional Centers are set up to assist you with any technical questions. Just call one of the following numbers. Mahwah, NJ (201) 529-1616; Philadelphia, PA (215) 768-8845; Irving, TX (214) 550-5269; Atlanta, GA (404) 953-5858; Honolulu, HA (808) 834-6622; Niles, IL (312) 647-2424; Detroit, MI (313) 347-2251; Costa Mesa, CA (714) 549-4836, San Jose, CA (408) 280-7675.

3. Training & Technical Departments. Because constant innovation is the rule in the field of consumer

electronics, authorized servicers and Sony Service Center technicians need the latest information available. This information is provided through training sessions at our Regional Training facilities and publication of Service Bulletins by our Technical Department.

4. National Parts Centers. All Sony Service Centers, parts distributors and authorized servicers depend on the National Parts Center. The Center also provides up-to-date service manuals and training tapes. To receive the Comprehensive Service Literature brochure free of charge write: Sony Service Company, National Parts Center, 8281 NW 107th Terrace, Kansas City, MO 64153 Attention Publications Department or call (816) 891-7550.

SONY®

Sony Service Company

A Division of Sony Corporation of America

Looking for parts information?

Here's help

By Conrad Persson

Did you know that if you can find a UL manufacturer's code number or an FCC ID number on a TV or VCR, you can use that number to identify the manufacturer? Did you know that if you have the right VCR cross reference, you might be able to use a VCR servicing manual that you already have from a well-known manufacturer to troubleshoot a VCR from a manufacturer you've never heard of? You might even have some of the needed replacement components in stock and might be able to identify them. In today's world, tracking down manufacturers of consumer electronics products and the servicing literature and replacement components

needed to fix their products can present serious problems. Armed with some of the information in this article, however, you might be able to solve some of those problems without too much effort.

In some cases, when you're fixing a VCR, it makes sense to replace more than just the particular component that caused the failure; related wear components are likely to fail in the near future. Not only does it make sense, but some manufacturers are now offering mechanical component replacement kits to make the ordering of these related parts more convenient and less costly.

Here are the facts.

Finding replacement parts

To suggest that the replacement-parts

and servicing-information situation in the consumer electronics servicing business is completely insane is, perhaps, to understate the situation. There are many manufacturers who are diligently trying to maintain reasonable stocking levels of repair parts. They often spend considerable amounts of money to inform the industry how to find and order needed parts. On the other hand, there are many manufacturers who don't appear to care whether the consumers who buy their products can get them fixed.

In fact, there seem to be many consumer electronics products bearing brand names so obscure that it's almost impossible to track the unit back to the manufacturer.

Fortunately, there are ways to find this information. However, if you make it a practice to accept brands that you don't recognize for servicing, you will have to maintain a library of sorts to help you track down the manufacturers of some of those products.

Here's a list of references that are useful in tracking the manufacturer or parts distributors, a must-have for every electronics servicing facility:

Consumer Electronics Replacement Parts Source Book

Consumer Electronics Group, Electronic Industries Association
P.O. Box 19100
Washington, DC 20036
(Include \$1 for postage and handling)

Electronic Industry Telephone Directory (or some equivalent)

Harris Publishing Company
2057-2 Aurora Road
Twinsburg, OH 44087-1999
(Cost is about \$50)

Consumer Electronics Show (CES) Official Directory

Consumer Electronics Group, Electronic Industries Association
Temporary address:
1722 Eye St. NW, Suite 200
Washington, DC 20006

Persson is editor of ES&T.



VCR replacement parts kits

For years, many servicing organizations have understood the wisdom of replacing a group of parts when one of the parts has worn to the point of causing a failure. In many cases, it's actually not a bad idea to replace groups of parts before they fail. For example, in the automotive world, it's considered wise to replace all engine hoses and belts when one of these fails after the car is several years old. Even better is to replace them on a scheduled maintenance schedule and avoid the danger and inconvenience of having one fail when you're out on the highway. In industrial and commercial electrical maintenance, when it's time to replace light bulbs, group relamping is often practiced. If one or several lamps have failed, the rest are due, and it makes good economic sense to replace all of the lamps in a given area at once.

With VCRs, the situation is similar. If a belt or an idler tire fails, stretches, hardens or becomes glazed, it means the rubber has deteriorated as a result of aging or the effects of ozone. If the unit is a couple of years old, every rubber part in the unit also has aged considerably and might fail soon. Also, by the time a rubber part has failed, many of the parts that rub and wear probably will have worn to the point that they will either fail soon or not operate properly. Conversely, if bearing parts have worn to the point that they are failing or out of tolerance, all of the wear parts and rubber parts in the machine are likely to be worn to the point of being out of tolerance or near failure.

Here is what a Hitachi service bulletin says about the situation:

The video recorder is a precision electromechanical device that has a number of mechanical parts subject to wear. Rubber parts become hardened and glazed, clutches bind, and belts stretch and slip. Usually when a repair is performed, wear-related parts are not replaced unless they are causing a problem. While a product is still fairly new, it is usually safe to assume that such parts are in good condition and do not need to be replaced. But at some point during the product life, replacement of all low-cost wear parts is recommended in order to avoid a series of related failures.

From the viewpoint of the customer, the time for such maintenance is during the course of other repairs that occur when mechanical maintenance is likely to be needed. Although maintenance is due after more than two years of use, wear parts sometimes are not replaced during a repair because the customer or technician does not realize they are needed, or simply because the parts are not available in bench stock.

To meet customer desires for quality repairs and servicer requests for simplified ordering of wear parts, we [Hitachi] researched the needs on our most

popular video recorder models. Then we combined the most needed and ordered wear parts into a package that simplifies part ordering and encourages a good repair.

Hitachi's suggested use for a parts kit:

1. At the customer option for non-mechanical repairs after more than two years of use.

2. When other transport-related mechanical problems are being repaired after more than two years of use. Such problems include:

- intermittent mechanical FF/RWD/Search/Play operation.
- excessive wow/flutter.
- unusually slow servo lock at the start of play, end of search, or after a speed change. (If the servo is electrically OK.)
- replacement of worn video heads.

When mechanical maintenance is performed, the capstan bearing and reel table shafts should be lubricated and the tape path should be cleaned.

Here is a list of the parts found in one of the VCR mechanical maintenance parts kits: main loading belt, back tension belt, main belt, pressure roller, FF/REW belt, clutch assembly, T/U idler, and pressure roller washer.

Besides putting all of the wear parts in one package for convenience, ordering a kit instead of individual parts is less expensive, representing a savings of about 25% to the dealer and to the customer.

RCA also is offering mechanical maintenance parts kits for its VCRs. Other manufacturers either do so, or soon will.

The CES directory includes a Brand Name section, which lists the booth numbers where all of the brand names will be exhibited at the show. The booth number listings then show which companies will be in which booths. For example, if you look up a Conic TV in the Brand Names section, you find the booth number. The booth number section will then show you that Cony Electronics is the manufacturer and give the address.

The best way to get a copy of the directory is to attend the Consumer Electronics Show. It comes with the price of attendance. If you can't get to the show, limited quantities will be available to ES&T readers who send in the coupon at the right. Quantities are limited, but the EIA/CEG will fill as many orders as possible.

A VCR parts reference

Another invaluable reference is published by the Arizona State Electronics Association (ASEA): *The VCR Model Number and Parts Reference* is available for \$33 plus \$3 postage and handling from NESDA (National Electronic

Servicing Dealers Association), 2708 W. Berry St., Fort Worth, TX 76109; 817-921-9062. This is a 2-part reference that will help VCR servicing organizations locate by cross-reference different brands made by the same manufacturer. Part 1 of this reference will allow the

Please send me a copy of the *Consumer Electronics Show Official Directory*, as mentioned in *ES&T*. Enclosed is a check for \$12, payable to the Consumer Electronics Show. (For *ES&T* readers only. Regular price is \$25.)

Name _____

Address _____

City _____ State _____ Zip _____

Mail to: CES, Attn. Patty Kain, 1722 Eye St. NW, Suite 200, Washington, DC 20006.

If you want better measurements, check these figures out.

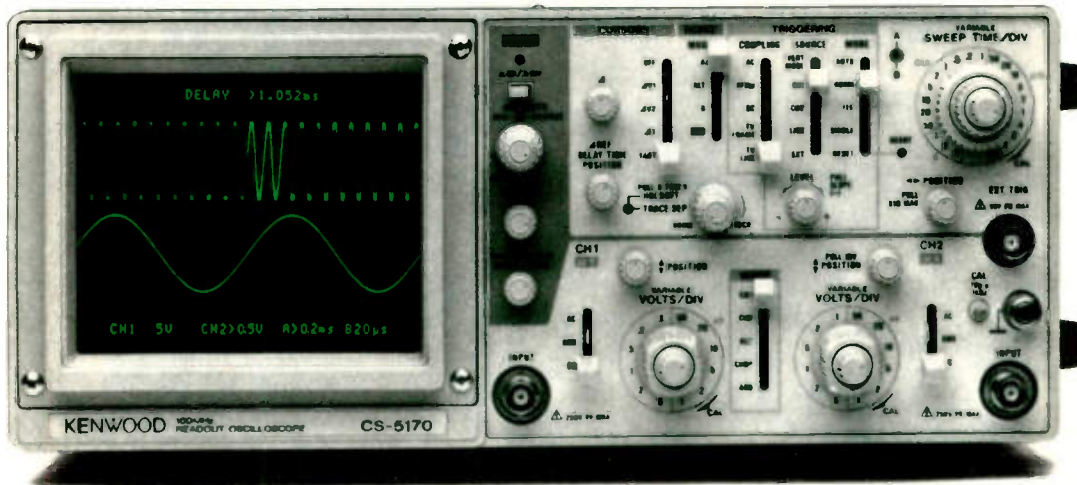

100 MHz \$1595
CS-5170

The Kenwood CS-5170. No other dual-channel 100MHz oscilloscope more economically combines performance and simplicity. And through December 31, 1989, its reasonable price has been reduced almost beyond reason.

You see, the CS-5170 forgoes unnecessary extras in favor of the practical features that make high-speed signal readings quick and easy. Like digital readout with cursor functions for voltage, time, frequency, ratio, phase, and delay measurements. The CS-5170's high-resolution 12kV CRT eliminates parallax error. Delayed sweep, high vertical-axis sensitivity from 1mV to 5V, automatic triggering and video signal capabilities all add to this scope's optimum functionality.

Prudent performers. For economical electronics, the 3-channel 60MHz CS-5165, 50MHz CS-5155 and 2-channel 40MHz CS-5135 models feature delayed



60 MHz \$1095
CS-5165

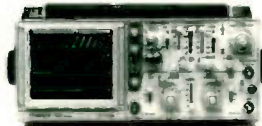

50 MHz \$995
CS-5155



40 MHz \$895
CS-5135

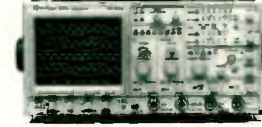

100 MHz \$1995
CS-6010



150 MHz \$2395
CS-6020

sweep, bright CRTs, 1mV to 5V vertical-axis sensitivity and more.

Advanced 4-channel oscilloscopes. Kenwood's 6000 Series, the 150 MHz CS-6020 and 100MHz CS-6010, deliver added versatility for advanced applications. Cursor measurements include voltage, time, frequency, ratio, phase, and delay. Both models offer digital readout with a convenient calendar display and bright CRT. A trigger counter is useful for analysis of complex digital and video signals.

Irresistible prices. Consider all the features you get with sophisticated Kenwood Test and Measurement Equipment and the figures you see here look all the more attractive.

To get FREE information on any or all Kenwood oscilloscopes contact Kenwood USA Corp.—Communications & Test Equipment Group at 2201 E. Dominguez Street, Long Beach, CA 90810. Or call (213) 639-4200.

KENWOOD

DELIVERY IS THE MOST IMPORTANT FUNCTION OF A PARTS DISTRIBUTOR. BUT IT'S NOT ENOUGH.



MATSUSHITA AUTHORIZED PARTS-LINK™ DISTRIBUTORS. BECAUSE IT PAYS TO BE SURE.

Some distributors are quick to promise fast delivery of replacement electronic parts. But they may not always be the right parts. That's never a problem when you put your trust in a Matsushita Authorized PARTS-LINK™ Distributor — your best source for Panasonic, Technics and Quasar original replacement parts. For basic stocking, each distributor maintains over 1,000 of the most demanded part numbers for off-the-shelf delivery. Even if the part you need isn't so common, your Matsushita distributor is tied into our exclusive PARTS-LINK™ network, tracking over 385,000 part numbers, so that we can locate the part you need, lock in the order, and deliver it — if overnight delivery is requested to your doorstep within 24 hours. They can even cross-reference these original

replacement parts to other Matsushita built products so that you can retain the high quality and reliability of Matsushita's design.

THE DIFFERENCE BETWEEN A PROMISE KEPT, AND A PROMISE BROKEN.

Your Matsushita Authorized PARTS-LINK™ Distributor isn't authorized by accident; each has met (and continues to meet) stringent requirements to ensure fast, courteous and responsive service backed by Matsushita's replacement parts warranty.

The right part at the right time from the right source. For the name and location of your Matsushita Authorized PARTS-LINK™ Distributor — see our listings at right. **YOUR SOURCE OF CONFIDENCE.**



MATSUSHITA SERVICES COMPANY

50 Meadowland Parkway, Secaucus, NJ 07094

Panasonic Technics Quasar

MATSUSHITA

AUTHORIZED REPLACEMENT PARTS DISTRIBUTORS

Panasonic® • Technics™ • Quasar®

ARIZONA

ARIZONA WHOLESALE SUPPLY CO (C/M) • 2020 E. University Dr. Phoenix 85062 • 602-258-7901
ELECTRONIC PARTS CO. (C/V/M) • 4021 N. 31st. Ave., Phoenix 85017 • 602-277-7281

CALIFORNIA

ANDREWS ELECTRONICS (C/V/M) • 25158 Avenue Stanford, Valencia 91355 • 805-257-7700
AUDIO VIDEO PARTS, INC. (C/V/M/A) • 1071 South La Brea Ave., Los Angeles 90019 • 213-933-8141
CASS ELECTRONICS (C/V/M/A) • 801 Seventh Ave., Oakland 94606 • 415-839-2277
CHUCK HURLEY ELECTRONICS (C/M/A) • 2557 Albatross Way, Sacramento 95815 • 916-927-5891
E AND K PARTS, INC. (C/V/M/A) • 2115 Westwood Blvd., Los Angeles 90025 • 213-475-6848
HURLEY ELECTRONICS (C/M) • 10712 Inglewood Ave., Inglewood 90304 • 800-356-8734
HURLEY ELECTRONICS (C/M) • 730 W. Spruce, San Bernardino 92410 • 714-885-0721
HURLEY ELECTRONICS (C/V/M) • 318 16th St., San Diego 92101 • 619-235-6245
HURLEY ELECTRONICS (C/M) • 2101 N. Fairview, Santa Ana 92706 • 714-971-2992
PACIFIC COAST PARTS (C/V/M/A) • 15024 Staff Court, Gardena 92048 • 213-515-0207
WHOLESALE VACUUM (V) • 5811 Rose Ave., Long Beach 90813 • 213-428-6411

COLORADO

DENVER WALKER WINTRONICS (C/M) • 1001 W. Arizona Ave., Denver, 80223 • 303-744-9505

CONNECTICUT

SIGNAL ELECTRONICS SUPPLY, INC. (C/M/A) • 589 New Park Ave., West Hartford 06110 • 203-233-8551

FLORIDA

HERMAN ELECTRONICS (C/V/M/A) • 1365 N.W. 23rd St., Miami 33142 • 305-634-6591
LAYCO, INC. (C/V/M) • 501 South Main St., Crestview 32536 • 904-682-0321
VANCE BALDWIN (C/A/M) • 2207 S. Andrews Ave., Fort Lauderdale 33316 • 305-523-3461
VANCE BALDWIN (C/M/A) • 1801 NE 2nd Ave., Miami 33132 • 305-379-4794
VANCE BALDWIN (C/V/M/A) • 1007 N. Himes Ave., Tampa 33607 • 813-870-2606
VANCE BALDWIN (C/V/M) • 500 Clematis St., West Palm Beach 33401 • 407-832-5671

GEORGIA

BUCKEYE VACUUM CLEANER (V) • 2870 Plant Atkinson Rd., Smyrna 30080 • 404-351-7300
WHOLESALE INDUSTRIAL (C/M/A) • 5925 Peachtree Corners East, Norcross 30071 • 404-447-8436

HAWAII

PANASONIC HAWAII, INC. (C/V/M) • 99859 Iwaiwa St., PO Box 774, AIEA, HI 96701 • 808-488-1996

ILLINOIS

B-B & W, INC. (C/V/M) • 2137 S. Euclid Ave., Berwyn 60402 • 312-242-1533
HESCO, INC. (V) • 6633 North Milwaukee Ave., Niles 60648 • 312-647-6700
JOSEPH ELECTRONICS, INC. (C/M/A) • 8830 N. Milwaukee Ave., Niles 60648 • 312-297-4200
UNION ELECTRONIC DIST. (C/V/M/A) • 16012 S. Cottage Grove, South Holland 60473 • 312-333-4100
YEOMANS DISTRIBUTING CO. (C/V/M) • 1503 W. Altorf Dr., Peoria 61614 • 309-691-0050

INDIANA

ELECTRONIC SERVICE PARTS (C/V/M) • 2901 E. Washington St., Indianapolis 46201 • 317-269-1527

IOWA

JONES DISTRIBUTING CO. (C/V/M/A) • 2650 Bndgeport Dr., Sioux City 51111 • 712-277-8600
YEOMANS DISTRIBUTING CO. (C/M) • 616 New York Ave., Des Moines 50313 • 515-280-8179

KANSAS

G & A DISTRIBUTORS, INC. (C/V/M/A) • 635 N. Hydraulic St., Wichita 67201 • 316-262-3707

KENTUCKY

MAJOR DISTRIBUTING COMPANY (C/M) • 449 S. 16th St., Paducah 42003 • 502-443-5345
SERVICE ELECTRONICS SUPPLY (C) • 10464 New Circle Rd., NE, Lexington 40505 • 606-254-5786

MARYLAND

FAIRWAY ELECTRONICS (C/V/M) • 3040 Waterview Drive, Baltimore 21230 • 301-576-8555
FAIRWAY ELECTRONICS (C/V/M/A) • 4210 Howard Ave., Kensington 20795 • 301-564-1440
TRITRONICS, INC. (C/V/M/A) • 1306 Continental Dr., Abingdon 21009-2334 • 301-676-7300

MASSACHUSETTS

MIL ELECTRONICS (C/V/M/A) • 27-33 Jones Rd., Waltham 02154 • 617-891-6730
SIGNAL ELECTRONICS SUPPLY, INC. (C) • 484 Worthington St., Springfield 01105 • 413-739-3893
TEE VEE SUPPLY CO. (C/V/M/A) • 407 R Mystic Avenue, P.O. Box 649, Medford, MA 02155 • 617-395-9440

MICHIGAN

G.M. POPKEY CO. (C/V/M/A) • 4477 East Paris Ave. S.E., Grand Rapids 49512 • 616-698-2390
REMCOR ELECTRONICS (C/M/A) • 10670 Nine Mile Rd., Oak Park 48237 • 313-541-5666

MINNESOTA

NESS ELECTRONICS, INC. (C/V/M/A) • 441 Stinson Blvd. NE, Minneapolis 55413 • 612-623-9505
MID AMERICA VACUUM CLEANER SUPPLY CO. (V) • 666 University Ave., St. Paul 55104 • 612-222-0763

MISSISSIPPI

TRI-STATE ELECTRONICS (C/V/M) • 605 W. Fortification St., Jackson 39203 • 601-355-3431

MISSOURI

CITITRONIX, INC. (C/V/M/A) • 1641 Driellman Rd., St. Louis 63132 • 314-427-3420
MANHATTAN ELECTRONICS, INC. (C/V/M) • 1101C E. 76th Terrace, Kansas City 64131 • 816-361-9440
TACONY CORP. (V) • 1760 Gilsmn Lane, Fenton 63036 • 314-349-3000

NEW HAMPSHIRE

TEE-VEE SUPPLY CO. (C/V/M/A) • 58 Elm St., Nashua 03060 • 603-889-4171

NEW JERSEY

NIDISCO ELECTRONICS (C/V/M/A) • 181 Route 46 W. Lodi 07644 • 201-773-1771

NEW YORK

DALE ELECTRONICS (C/V/M/A) • 7 E. 20th St., New York City 10003 • 212-475-1124
GREEN TELE-RADIO DIST. (C/M/A) • 84-00 73rd Avenue, Glendale 11385 • 718-821-1114
GMB SALES (C/V/M/A) • 140 Terminal Rd., Setauket 11733 • 516-689-3400
MILL ELECTRONIC SUPPLY (C/V/M/A) • 2026 McDonald Ave., Brooklyn 11223 • 718-336-4575
PAGO APPLIANCE PARTS (C/M/A) • 700 Broadway, Buffalo 14212 • 716-856-8133
PANSON ELECTRONICS (C/V/M/A) • 268 Norman Avenue, Greenpoint 11222 • 718-383-3400
RADIO EQUIPMENT CORP. (C/A) • 196 Vulcan St., Buffalo 14207 • 716-874-2690
STAR FOR PARTS (V) • 250 Rabro Drive East, Hauppauge 11788-0255 • 800-525-6046
UNITED TELETRONIC PARTS (C/M) • 3860 10th Ave., New York 10034 • 212-569-2330

NORTH DAKOTA

WESTECH DISTRIBUTING (C/V) • 1345 Main Ave., Fargo 58103 • 701-237-4885

OHIO

FOX INTERNATIONAL, INC. (C/V/M/A) • 23600 Aurora Rd., Bedford Heights 44146 • 216-439-8500

OREGON

DIVERSIFIED PARTS (C/V/M/A) • 2104 S.E. 9th Ave., Portland 97214 • 503-236-6140
THE MOORE CO. (C/V/M) • 333 SE 2nd, Portland 97214 • 503-234-5000

PENNSYLVANIA

AMERICAN VAC DISTRIBUTORS (V) • 3130 E. Thompson St., Philadelphia 19134 • 215-423-4522
CRS ELECTRONICS (C/M) • 818 Brownsville Rd., Pittsburgh 15210 • 412-431-7700
LINWOOD WHOLESALE, INC. (C/M) • 1139 Sumner Ave., Whitehall 18052 • 215-820-0357
STEINBERG ELECTRONICS (C/V/M/A) • 2520 N. Broad St., Philadelphia 19132 • 215-223-9400

RHODE ISLAND

JABBOUR ELECTRONICS (C/V/M/A) • 1744 Cranston St., Cranston 02920 • 401-944-2570

SOUTH CAROLINA

WHOLESALE INDUSTRIAL (C/V/M) • 515 E. Bay St., Charleston 29403 • 803-722-2634

TENNESSEE

CURREY'S, INC. (C) • 923 8th Ave., S. Nashville 37203 • 615-242-4223
MILLS MORRIS CO. (C/V/M/A) • 677 Phelan Ave., Memphis 38101 • 901-774-9810
SHIELDS ELECTRONICS SUPPLY, INC. (C/V/M/A) • 4722 Middlebrook Pike, Knoxville 37921 • 615-588-2421

TEXAS

ELECTRONIC COMPONENT (C/V/M/A) • 2401 Bissonnet, Houston 77005 • 713-528-1543
FOX INTERNATIONAL (C/V/M) • 752 So. Sherman, Richardson 75081 • 214-231-1826
M-TRONICS (C/V/M/A) • 3201 West Ave., San Antonio 78213 • 512-340-4069
PORTER BURGESS CO. (C/V/M) • 1233 Levee St., Dallas 75207 • 214-741-5161
SHERMAN ELECTRONICS (C/V/M) • 702 San Pedro Ave., San Antonio 78212 • 512-224-1001
SHERMAN ELECTRONICS (C/V/M) • 1701 Morgan Ave., Corpus Christi 78404 • 512-888-9454
SOUTHWEST MANUFACTURERS, INC. (V) • 3243 S. Jones St., Fort Worth, TX 76110-4397 • 817-926-8281
VCP INTERNATIONAL INC. (V) • 2285 Merritt Dr., Garland 75040 • 214-271-7474

VIRGINIA

AVEC ELECTRONICS CORP. (C/M) • 711 Granby St., Norfolk 23510 • 804-627-3502
AVEC ELECTRONICS CORP. (C/M) • 2002 Staples Mill Rd., Richmond 23230 • 804-359-6071
FAIRWAY ELECTRONICS, INC. (C/V/M) • 2304 Chamberlayne Ave., Richmond 23222 • 804-321-7255

WISCONSIN

DYKRO, INC. (C/V/M) • N90 W14401 Commerce Dr., Menomonee Falls 53051 • 414-255-1900
G.M. POPKEY COMPANY (C/V/M/A) • 2035 Larsen Rd., Green Bay 54307-2237 • 414-497-0400

CODING:

(C) . . . Consumer Electronic Parts
(V) . . . Vacuum Parts
(M) . . . Major Appliance Parts
(A) . . . Accessories

(as of 9/1/89)

Matsushita Services Company, 50 Meadowland Parkway, Secaucus, NJ 07094

The FCC public-access information system

Every VCR, personal computer, microwave oven and cordless phone sold in the United States must bear an FCC identification number because they are considered to be potential generators of radio-frequency interference. This number identifies which company manufactured the unit. If you have one of these products in your shop for service and can't identify the manufacturer, you can contact the FCC through its public-access system and find out.

There are two ways to get this information: via telephone or via computer

and modem by contacting the public-access bulletin board. The FCC prefers to have people use direct computer-to-computer contact.

To contact the FCC bulletin board, you must have a computer and a modem capable of 300 baud or 1,200 baud. The number to call, in Maryland (just outside of Washington, DC), is 301-725-1072. This is a toll call. Dialing this number should get you in direct contact with the bulletin board. Just follow the instructions. Your call will be limited to 15 minutes.

The other method of obtaining this information is to call 301-725-1585, Monday through Thursday between 2:00 p.m. and 4:30 p.m. and ask to be connected to the status desk. The individual who answers will relay your question to the bulletin board via a computer terminal, and will then relay the information it provides to you.

Obviously, if you have a computer with a modem, it makes far more sense to contact the computer directly. You'll cut out the middleman, and, of course, you can contact the computer anytime.

FCC ID numbers	
Manufacturer	FCC ID Number
Akai	ASH
Fisher	AFA
GE	AJU
Goldstar	BEJ
Hitachi	ABL
Lloyds	ADT
Magnavox	BOU
Mitsubishi	BGB
NEC	A3D
Panasonic	ACJ
RCA	AHA
Samsung	A3L
Sharp	ATA
Shintom	EOZ
Sony	AK8
Sylvania	AIX
Symphonic	ADT
TMK	A7R
Toshiba	AGI
Zenith	ASI

Figure 3. The FCC requires an ID number on any product that might cause interference. This list of number prefixes may help you identify a product's manufacturer.

UL numbers for VCR manufacturers (unofficial)		
UL number	Manufacturer	Brand names
16M4	Samsung	Supra, Multitech, Unitech, Tote Vision, Cybrex, GE, RCA
174Y	Toshiba	Sears
238Z	Hitachi	RCA, GE, Penny, Pentax
333Z	Symphonic	Teac, KTO, Realistic, Multitech, Funai, Porta Video, Dynatech, TMK
403Y	Fisher/Sanyo	Realistic, Sears
439F	JVC	Zenith, Kenwood, Sansui
44L6	TMK	Emerson, Lloyds, Brooksonic
504F	Sharp	Wards, KMC
51K8	Portavideo	
536Y	Mitsubishi	Emerson, Video Concepts, MGA
570F	Sony	Zenith
679F	Panasonic	RCA, GE, Magnavox, Quasar, Canon Philco
781Y	NEC	Dumont, Video Concepts, Vector, Sears
86B0	Goldstar	Realistic, JCPenney, Tote Vision, Shinton, Sears, Memorex

Figure 4. This is an unofficial list of manufacturer code numbers assigned by Underwriters Laboratories. If you have a product in the shop for service and the UL code number on it matches one of the numbers on the list, you know who manufactured the product, even if the brand name is different.

manufacturers they represent. Again, this listing is unofficial, provided by a reader, and may not be totally correct. We're working on expanding both lists and checking them for accuracy. For now, we felt that this information, although incomplete and needing verification, was so vital to all readers that we should get it into print. According to NESDA, they're working on adding the UL information to the next edition of the VCR model number and parts reference.

The list of FCC ID numbers and UL manufacturers code numbers was provided by Jim Teeters, CET/CSM.

According to him, credit for compiling these lists goes to many hard-working people who belong to electronics associations in Florida, Louisiana, New York, Ohio and Virginia. Thanks to all of you who made these lists possible.

This list is something else to which readers of this magazine can contribute. If you find errors or can add entries to either list, please let us know. We will be publishing comprehensive lists of this type of information as they are updated. Perhaps one day, armed with these lists, a servicing technician will be able to immediately identify the manufacturer of any unit that comes into his shop.

Information Exchange

Here at ES&T, we are trying to gather as much information as we can to help our readers find both servicing information and replacement parts for obscure (and not so obscure) product brands. The strength of the magazine in finding this kind of information is the size of our readership and the willingness of readers to share information. The sidebar "Information Exchange" (see page 15) is a comprehensive list of all of the information we have unearthed to date via our Information Exchange department.

Our thanks to those readers who have

Information Exchange

Akai

Servicing literature and replacement parts for Akai products are available from:

Mitsubishi Electric Sales America
National Service Department
5757 Plaza Drive
P.O. Box 6007
Cypress, CA 90630-0007
800-553-7278
714-220-2500

BSR parts

Service, repair and parts for BSR equipment is available from:

Carillon Technology
707 E. Evelyn Ave.
Sunnyvale, CA 94086
408-720-9800

Bohsei parts

Available from:

Audio Parts Co.
1070 S. Orange Drive
Los Angeles, CA 90019
213-933-2141

Conic, Contec

Manufactured by:

Cony Electronics
222 S. Riverside Plaza, Suite 1550
Chicago, IL 60606
312-207-0017

The Conic model T-7711A is the same as the Radio Shack unit, catalog 16-234, according to one reader.

Dokorder

Sources for belts for the model 7140 Dokorder reel-to-reel tape recorder are available from the following suppliers:

Prime Electronics
P.O. Box 28
Whitewater, WI 53190
800-558-9572
Fax: 414-473-4727

Indiana Wholesale Electronics
514 Third Street
Aurora, IN 47001
812-926-4344

Emerson VCR parts

The STK5486 replacement IC voltage regulator chip for an Emerson model VCS966A VCR is listed in the MCM Electronics catalog:

MCM
650 Congress Park Drive
Centerville OH 45459
800-543-4330

Other readers have indicated that Emer-

son parts are available from the following companies:

Electronics Warehouse
1910 Coney Island Ave.
Brooklyn, NY 11230
800-221-0424
Fax: 718-375-2796

Fox International
752 S. Sherman
Richardson, TX 75081
800-331-2501

The company address is:

Emerson Radio Corporation
One Emerson Lane
N. Bergen, NJ 07047
201-854-4800

Fisher

The Sanyo Fisher Service Corporation strongly recommends ordering by fax, telex or mail.

Western Region:
1200 W. Artesia Blvd.
Compton, CA 90224
213-605-6742
Fax: 213-604-0925

Mid-West Region:
600 Supreme Drive
Bensenville, IL 60106
312-350-1505
Fax: 312-350-1621

Eastern Region:
210 Riser Road
Little Ferry, NJ 07643
201-641-3000
Fax: 201-641-1791

Southern Region:
1790 Corporate Drive #340
Norcross, GA 30093
404-925-8900
Fax: 404-925-9308

Goldstar

The company address is:

Goldstar Electronics International
1050 Wall St. W.
Lyndhurst, NJ 07071
800-225-2550

Grundig stereo equipment

Servicing manuals and replacement parts for *some* Grundig units are available from:

Act Electronics
Parts Department
2345 E. Anaheim St.
Long Beach, CA 90804
214-433-0475

Sidebar continued on page 16.

New mother- boards and chassis.

PTS has hundreds of motherboards/chassis available for immediate exchange. Plus, PTS has factory-trained technicians for quality, complete motherboard, chassis, electronic tuners and tuner clusters remanufacturing service. Exact replacement motherboards/chassis from PTS meet or exceed industry standards. These are just a few of the hundreds of motherboards/chassis available from PTS!

Magnavox

APW002
A100026
EMH103

Zenith

9-470
9-516
9-770
9-592

RCA

CTC145
CTC149
CTC136

GE

EP93X535
EP93X488
EP93X631

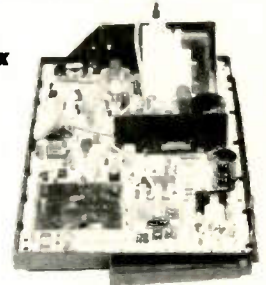

Depend on PTS for savings, speed and quality!
Order direct and save!

1-800-333-PTS-1

To order - or for the servicenter or distributor nearest you - call today!



FREE PRODUCT GUIDE!

Call today for your FREE copy of the PTS Catalog and Parts Reference Guide! Comprehensive listing of the world's largest inventory of TV modules, motherboards, tuners, thousands of exact replacement parts. Plus new sections on VCR parts and service, new products, rebuilding services, and more!

PTS

PTS Corporate Headquarters
P.O. Box 272, Bloomington, IN 47402

Circle (13) on Reply Card

Information Exchange

Continued from page 15.

Kawasho

The company address is:
Kawasho International
1500 Clinton St., Bldg. 747
Buffalo, NY 14206
800-922-1722
716-821-0747

Kawasho flybacks are also available from:

Electo Dynamics
898 Route 106
E. Norwich, NY 11732
800-426-6423

Lloyds

The company address is:
Lloyds Electronics
180 Raritan Center Parkway
Edison, NJ 08818
210-225-2030

Lloyds model L838 series 821A VCR parts and Magnasonic TV parts are also available from:

M.L. Corporation
1959 Leslie St.
Donmills, Ont.
Canada, M3B 2M3

Hitachi

Hitachi doesn't stock manuals for products more than 10 years old. However, the company can photocopy schematics for these products for a nominal fee.

Hitachi Service Company
401 W. Artesia Blvd.
Compton, CA 90220
213-357-8383

MultiTech

Parts and servicing information for MultiTech, DynaTech, Spectrum and HiTech are available from Trans-World Electronics:

Trans-World Electronics
15304 E. Valley Blvd.
City of Industry, CA 91748
800-822-1236

The MultiTech MV-089 is identical to the Symphonic model 5200:

Symphonic Corporation
100 North St.
Teterboro, NJ 07608
800-242-7158

Phone-Mate

The company address is:
Phone-Mate
Customer Service
215 W. Old Country Road
Hicksville, NY 11801

Parts, schematics, etc., for Phone-Mate answering machines can be ordered from Audio Video Parts:

Audio Video Parts
P.O. Box 19670
1071 S. LaBrea Ave.
Los Angeles, CA 90019
213-933-8141

Samsung

Samsung and Astra brand products are manufactured by Samsung:

Authorized servicers:
Samsung Electronics
18600 Broadwick St.
Rancho Dominguez, CA 90220
800-634-8276

Non-authorized servicers:
Fox International Ltd.
23600 Aurora Road
Bedford Heights, OH 44146
800-321-6993

Vector Research

Vector Research is an audio company that sold specially designed VCRs manufactured in Japan. The company no longer offers VCRs for sale, but it will provide information for anyone needing to service one of its products.

Vector Research Service Department
1230 Calle Suerte
Camarillo, CA 93010
805-987-1312

Video Concepts

Mitsubishi will give its equivalent number for the Video Concepts HT2000.

Mitsubishi Electric Sales America
Attn: Service Parts Dept.
P.O. Box 6007
5757 Plaza Drive
Cypress, CA 90630-0007
800-553-PART
Fax: 800-825-6655

Books/Photofact

General Radiotelephone Operator's License Study Guide, 2nd edition, by Thomas LeBlanc; TAB Books; 230 pages; \$23.95 hardbound, \$15.60 paperback.

This guide provides a general review as well as specific information on the Radiotelephone Operator's License test, which was changed by the FCC in November, 1986. Improvements on the book since the change of test include an expanded section on telecommunications rules and regulations, and new chapters on troubleshooting and radar fundamentals. The author emphasizes concepts rather than memorization, and avoids exposing the reader to extraneous information.

TAB Books, Blue Ridge Summit, PA 17294-0850; 800-822-8138.

How To Keep Your VCR Alive; Worthington; 376 pages; \$24.95.

This book is an introduction to VCR servicing, including a universal VCR diagnostic procedure for localizing problems, plus step-by-step procedures for repairing them. Information from hundreds of manufacturers' service manuals is condensed into the appendices, including part numbers for most commonly need parts, and addresses and telephone numbers of parts sources for all VCR brands.

Worthington Publishing, 6907 Halifax River Drive, Suite 202F, Tampa, FL 33617; 813-988-5751.

Audio Technology Fundamentals, by Alan A. Cohen; Howard W. Sams; 250 pages; \$19.95.

The author provides an overview of the electric and electronic circuitry used in typical audio systems, assuming the reader has only a basic understanding of math and electronics principles. Topics covered include the audio chain, sound measurement, op-amps, passive and active filters, transformers, semi-conductors, the tape recorder, digital audio, practical audio circuits, troubleshooting and maintenance.

Howard W. Sams, 4300 W. 62nd St., Indianapolis, IN 46268; 317-298-5604.

How To Draw Schematics And Design Circuit Boards With Your IBM PC, by Steve Sokolowski; TAB Books; 192 pages; \$19.95 hardbound, \$13.60 paperback.

This book describes two computer-

sent in information in response to questions from other readers. We think we're making some real headway in getting this problem of information sorted out, but we have a long way to go. Please keep the questions and answers coming.

Unless otherwise noted, the address-

es and phone numbers are the best information we currently have to locate parts and servicing information for the listed manufacturers. If you try these addresses or phone numbers and find information to the contrary, please let us know. ■

aided software programs designed by the author for IBM PCs, Tandy 1000s or other compatible microcomputers. It shows how to use the programs to draw a 12V power supply and a printed circuit board to be used with it. Step-by-step instructions and diagrams are included.

TAB Books, Inc., Blue Ridge Summit, PA 17294-0850; 1-800-822-8138.

The Art of Electronics, second edition, by Paul Horowitz and Winfield Hill; Cambridge University Press; 1,152 pages; \$49.50.

This text emphasizes methods used by circuit designers — a combination of basic laws, rules of thumb and tricks of the trade. This edition includes new tables and revised topics, including microprocessors, digital electronics, microprocessor design, construction techniques, filters and regulators, FETs, op-amps and precision design.

Cambridge University Press, 32 57th St., New York, NY 10022.

Electronics Engineer's Reference Book, 6th edition, edited by Fraidoon Mazda; Butterworth Publishers; 1,000+ pages.

This edition of the reference has been expanded to include new segments on surface-mount technology, hardware and software design technique, semi-custom electronics, and data communications. It also has been updated to account for changes in standards, materials and techniques. The text covers techniques, physical phenomena, materials and components, electronic design and applications.

Butterworth Publishers, 80 Montvale Ave., Stoneham, MA 02180; 800-366-2665.

Portable Electronics Data Book, by John Douglas-Young; Prentice Hall; 360 pages.

This encyclopedia-style reference describes electronics terms and includes facts, figures and formulas used in electronics. A section on Calculus shows standard formulas and tables, plus a computer program for doing integration. Several computer programs are written in BASIC to help readers use the correct data and algorithms to do calculations.

Prentice Hall, Route 9W, Englewood Cliffs, NJ 07632; 201-767-5937.

Engineering Electronics, A Practical Approach, by Robert Mauro; Prentice Hall; 1,003 pages.

The text describes analog and digital electronics that use both discrete and integrated components. The book contains more than 700 figures, about 130 examples, 650 end-of-chapter problems and about 230 exercises with answers. Appendices cover network theory and techniques for analyzing transmission line problems.

Prentice Hall, Route 9W, Englewood Cliffs, NJ 07632; 201-767-5937.

PHOTOFACT

EMERSON

2695-1 EC1331
2697-1 EC1931

HITACHI

2693-1 CT2086B, CT2086W

JCPENNEY

2691-1 685-2519-00 (855-3869)
2692-1 685-2132M-00 (855-4065),
685-2508M-00 (855-3257),
685-4024M-00 (855-3430),
685-4025M-00 (855-0428),
685-4026M-00 (855-0436)
2694-1 685-2507M-00 (855-4073),
685-4110M-00 (855-3922),
685-4208M-00 (855-3422),
2696-1 685-2520-00 (855-3539)

PANASONIC

2694-2 CTK-2042R

RCA

2696-2 E13159EGF01,
E13164GMF01, E13165FWF01,
E13167WNF01, E13168NGF01,
E13169GMC01/GMF01
(CH. CTC145B/C)

SANYO

2695-2 AVM278 (A3R-27800),
AVM278SV (A5R-278SV0)

SEARS

2691-2 562.40811850
2697-2 564.42703850,
564.42704850

SHARP

2693-2 25NC158

ZENITH

2692-2 D1910B, D1912W,
SD1907W, SD1911W, SD3981H

Free new product guide.



Order your
FREE PTS

Catalog and Parts
Reference Guide today!

You'll have the industry's most complete in stock inventory of TV and VCR Exact Replacement Parts available overnight. All makes. All models. Plus new VCR Parts and VCR camcorder service, new disc drive and computer service, plus all makes of tuners, tuner clusters, modules, new motherboards/chassis and much more! Call toll free today and order your FREE PTS Catalog and Parts Reference Guide!

Now PTS ships Federal Express for as little as \$2.00 over UPS ground rates. And every in stock order received before 2:00 pm. is shipped the same day. That's PTS Express Service!

To order — or for the servicerenter or distributor nearest you — call today!

1-800-333-PTS-1

PTS

PTS Corporate Headquarters
P.O. Box 272, Bloomington, IN 47402

Circle (14) on Reply Card

Troubleshooting Tips

Symptom: blown fuse

Set ID: GE 8-1972

Photofact: none listed (similar to RCA, Photofact 2596-1).

This set was completely dead when it was brought in. A quick check revealed that the line fuse was blown. (See Figure 1.) My first suspicion naturally was that a problem existed in the power supply. I checked all the diodes and the main filter for shorts or leakage, but there were no problems there.

It occurred to me that it might be wise to consult someone who had a great deal of experience with RCA sets, so I checked with a local service shop technician/owner who was familiar with RCA chassis. He suggested the possibility that some of the tuner modules might not be the correct units for this set, and he said that if I unplugged certain connectors the short would disappear. I checked these possibilities, each time blowing a new fuse (4A, T-series), also noting that R101, the 3.9Ω, 10W resistor, overheated excessively in the time it took to blow the fuse. This resistor eventually succumbed to the stress and had to be replaced.

I next sat down with a DMM and traced the power-supply lines: perhaps something supplied by the 120V source was loading the power supply excessively. This line of investigation yielded positive results — I discovered a low resistance reading. I desoldered each connection on the foil connection for that line, but the low resistance reading didn't change.

Thinking that perhaps one of the capacitors in the area of the flyback transformer might be shorted, I began investigating in that area. I discovered that when I unplugged one of the yoke plugs, the short disappeared, which meant the problem was somewhere on the other side of the plug. A resistance reading of 3Ω to 4Ω from the jack to ground confirmed the location of the short.

Further investigation revealed that ca-

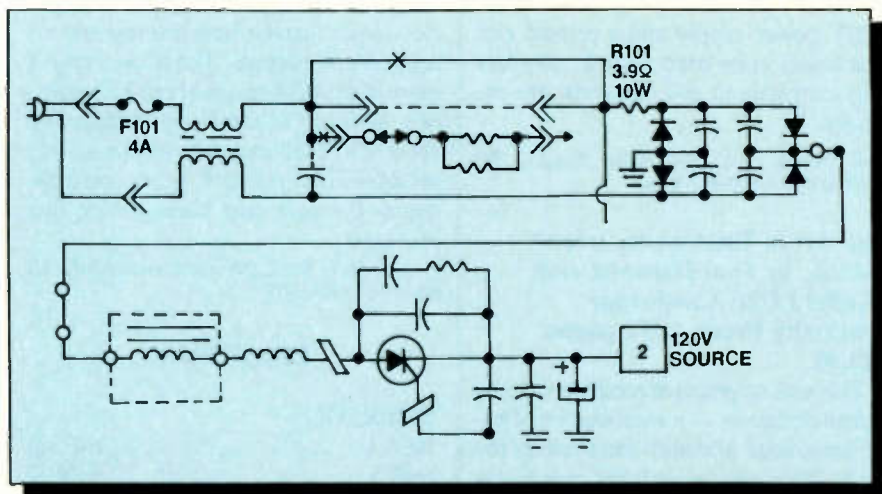

Figure 1. A quick check revealed that a blown line fuse was the problem with this dead set.

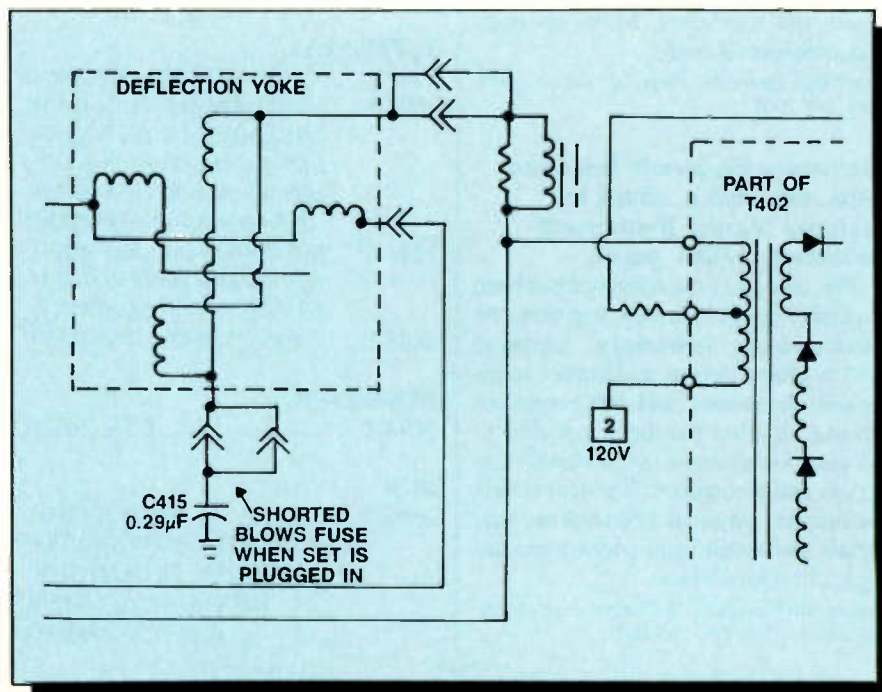

Figure 2. A shorted C45 was blowing fuse F101 whenever the set was plugged in.

pacitor C45 was shorted. (See Figure 2.) The capacitor, a 0.29μF device rated at 200Vdc, had to be specially ordered from RCA. Evidently it is a special high-frequency polycarbonate capacitor.

When the replacement arrived, I soldered it in and was pleased to observe that the set operated perfectly.

Phillip M. Jones, CET
Martinsville, VA

Test your electronics knowledge

By Sam Wilson, CET

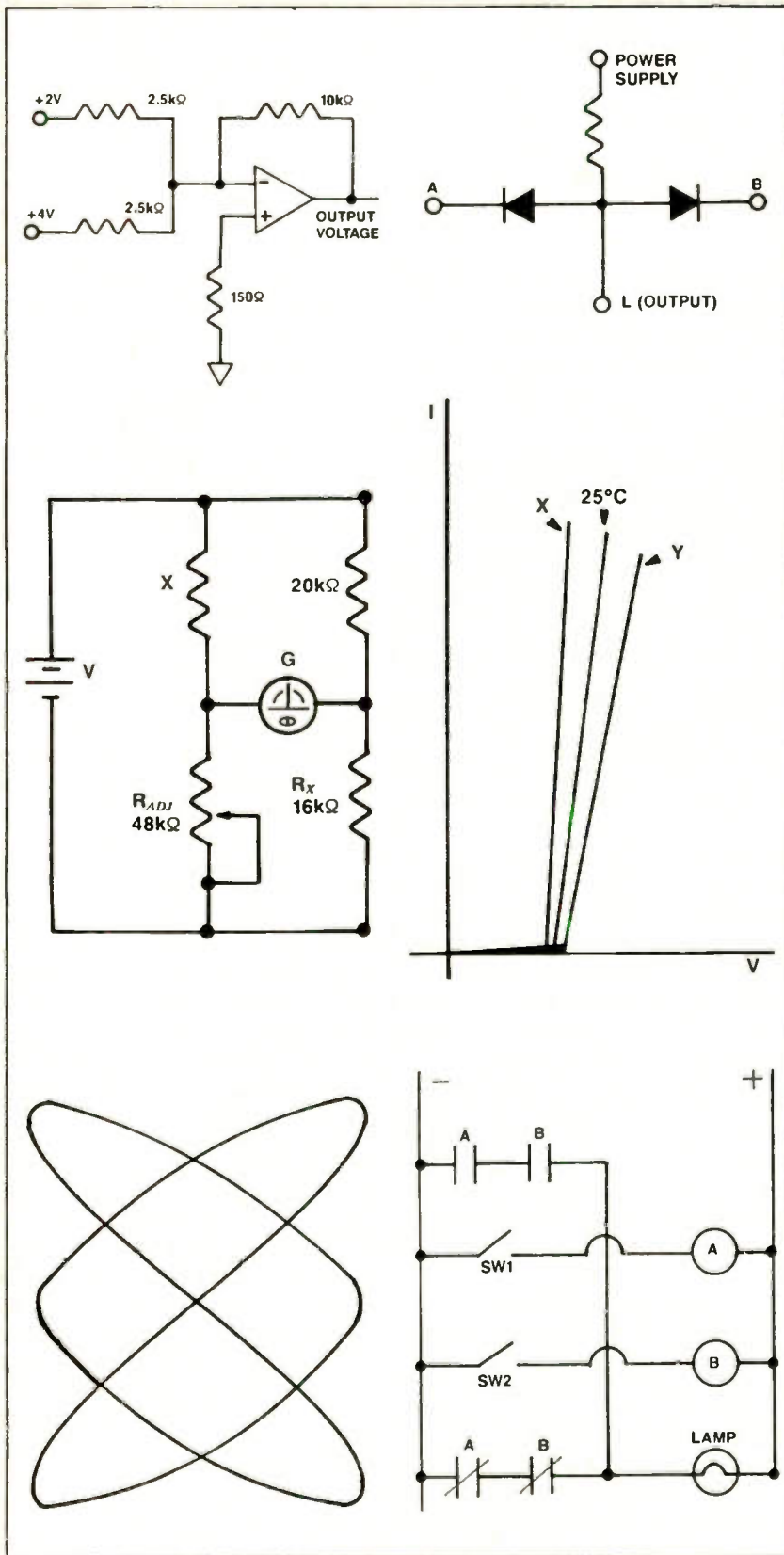

1. Which of the following is correct for finding bipolar transistor alpha?

- A. I_B/I_E
- B. I_C/I_E
- C. I_C/I_B
- D. $I_C \times \text{beta}$

2. Is the following statement correct? The current gain of an emitter follower is less than one.

- A. Correct
- B. Not correct

3. What should be the output voltage for the circuit in Figure 1?

4. Which bipolar transistor amplifier configuration can be used to match a low impedance to a high impedance?

5. What value of resistance at x in the circuit in Figure 2 will be required for the bridge to be balanced?

6. The Lissajous pattern in Figure 3 is obtained with a frequency of 150Hz delivered to the horizontal deflection plates. What is the frequency of the signal on the vertical deflection?

7. Which of the following is a piezoelectric material?

- A. barium titanate
- B. quartz
- C. human bone
- D. all of the above

8. The logic circuit in Figure 4 was drawn by Bobby Ordflug. He's not very good at drawing, but he has shown the correct connections for what kind of logic circuit?

9. Which of the silicon diode characteristic curves in Figure 5 might be for a temperature of 30°C?

10. In the relay ladder diagram in Figure 6, switch 1 is closed and switch 2 is open.

- A. The lamp is on.
- B. The lamp is off.

Answers are on page 24.

Wilson is the electronics theory consultant for ES&T.

Servicing Zenith microcomputers

Part V: Timing signals

By John A. Ross

In the previous article in this series (see the October issue), we laid the foundation for an understanding of semiconductor memory devices. Given the complexity of the task, it became necessary to review the technological evolution necessary for the efficient operation of the memory devices of today. We also defined different types of semiconductor memory devices and discussed some of the parameters that govern the operation of those integrated circuit designs. In Part V, we will now study how those devices work in the I50 series of the Zenith microcomputer line, and we'll discuss troubleshooting procedures.

Voltage supplies

Looking at the memory card shown in Figure 1, the technician must consider the voltage supplies required for the operation of the memory devices. Using the card edge connector as a logical starting point, you can trace the +5Vdc and ground lines (needed for the transistor-transistor logic devices) throughout the memory card. Pins B3 and B29 act as tie-points for the +5Vdc; pins B1, B10 and B31 work as tie-points for the ground plane. Following the +5Vdc line, you will find 5V supplied to pin 20 of ICs U455, U470 and U469; pin 14 of ICs U467, U456, U468 and U451; and pin 16 of ICs U465, U473, U474 and U454. Going to the random-access memory (RAM) devices, the +5Vdc appears at pin 8 of each integrated circuit, including U401 through U409, U411 through U419, U421 through U429, U431 and U439, and U441 through U449.

Ground connections are located at pin 10 of U455, U470 and U469; pin 7 of U467, U456, U468 and U451; pin 8 of U465, U473, U474 and U454; and pin

16 of the RAMs. Just as we use voltage and ground plane checks as a way of troubleshooting problems while working on entertainment electronics, we

We may use voltage checks as a way of narrowing the fault analysis in the microcomputer. The technician repairing the microcomputer has the added advantage of using disk-based diagnostics for pin-pointing the faulty integrated circuit.

may also use voltage checks as a way of narrowing the fault analysis in the microcomputer. The technician repairing the microcomputer has the added advantage of using disk-based diagnostics for pin-pointing the faulty integrated circuit. Although the diagnostics may not display a voltage/no voltage condition, the technician may combine the two troubleshooting methods in finding the fault. As we progress through the memory circuitry, we will continually refer to both the traditional method of troubleshooting and to the disk-based diagnostics.

Support circuitry

Even though the semiconductor memory devices make up the main part of the memory card, we should consider some of the other support circuitry that the card also contains before we analyze the memory circuit operation. Indeed, the operation of the timing and encoding circuitry becomes an integral part of the operation of the actual memory circuitry. U467 (an OR gate), U469 (a

tri-state octal buffer) and U456 (a delay line) control the cycle initiation and timing. Proper timing becomes essential to the access of a memory address. With the operation of this circuitry, three signals — RASTIM, CASTIM and MUXTIM — become recognizable and control the timing relationships.

A digital active low signal containing one of two possible sets of information appears at U469, the tri-state buffer. If the input-output (I/O) bus sends MEMR information, the signal appears at pin 2. If the bus relays MEMW information, the signal appears at pin 4. U467 inverts the signal and sends it through a digital OR operation. This OR operation leaves a digital high signal, which becomes the row-address strobe timing (RASTIM) signal, at pin 3 of U469. This RASTIM signal causes the RAM to latch onto the eight least significant bits on the I/O address bus and to select a row in the memory chip 256-by-256-bit matrix. Applying this signal to pin 3 of a memory-address controller, U455, and pin 1 of the delay line, U456, delays the RASTIM signal 40ns and applies a resulting multiplex timing (MUXTIM) signal to pin 1 of the memory address controller. U455 determines which row address strobe line to enable by using the I/O address bits A16 through A19. A normal read/write sequence will cause one of the address lines from RAS0 through RAS4 to go to a digital active low state. Only the memory bank associated with that line will enable.

System requirements come into play at this point. Because the architecture uses eight address lines, the necessity of addressing 64kbits or 256kbits dictates multiplexing the RASTIM and column address strobe (CASTIM) signals. A built-in delay time adds system stability before the CASTIM signal arrives. Sixty nanoseconds later, the CASTIM or signal shows at pin 8 of

Ross is a technical writer and a microcomputer consultant for Fort Hays State University, Hays, KS.

U456 and is applied to pin 2 of U455. This applied signal retrieves the eight most significant bits from the address bus and selects a column in the 256-by-256-bit matrix. Again, the system architecture uses multiplexing. Address multiplexing allows toggling between the low-order and the high-order bytes. Although each bank will receive a multiplexed address signal, only the bank that has the RAS signal will recognize the signal.

Timing sequences

A timing chart (shown in Figure 2) helps to depict the relationship between all of the timing signals. If a flaw occurs in the timing sequences, the memory-access portion of the memory operation will have problems. Instead of relying on disk-based diagnostics, the technician could depend on his troubleshooting expertise.

Again looking at Figure 2, the technician can use a multitrace oscilloscope, preferably with a 100MHz bandwidth, to check for proper timing. Multiple problems with memory access suggest that a problem has occurred in either the column-address timing, row-address timing or multiplex timing relationships. The technician generally will find that a faulty delay line, U456, will cause timing problems. Checking for timing problems calls for a combination of traditional troubleshooting methods and an on-board diagnostics aid. This check essentially calls for initiating a memory read or write operation through the ROM diagnostic sequences so the technician can watch the timing sequences and their relationships.

You enter the Monitor ROM diagnostics by pressing the Ctrl, Alt and Insert keys on the keyboard. This sequence will leave a prompt or > displayed at the upper left corner of the monitor display screen. These diagnostics contain

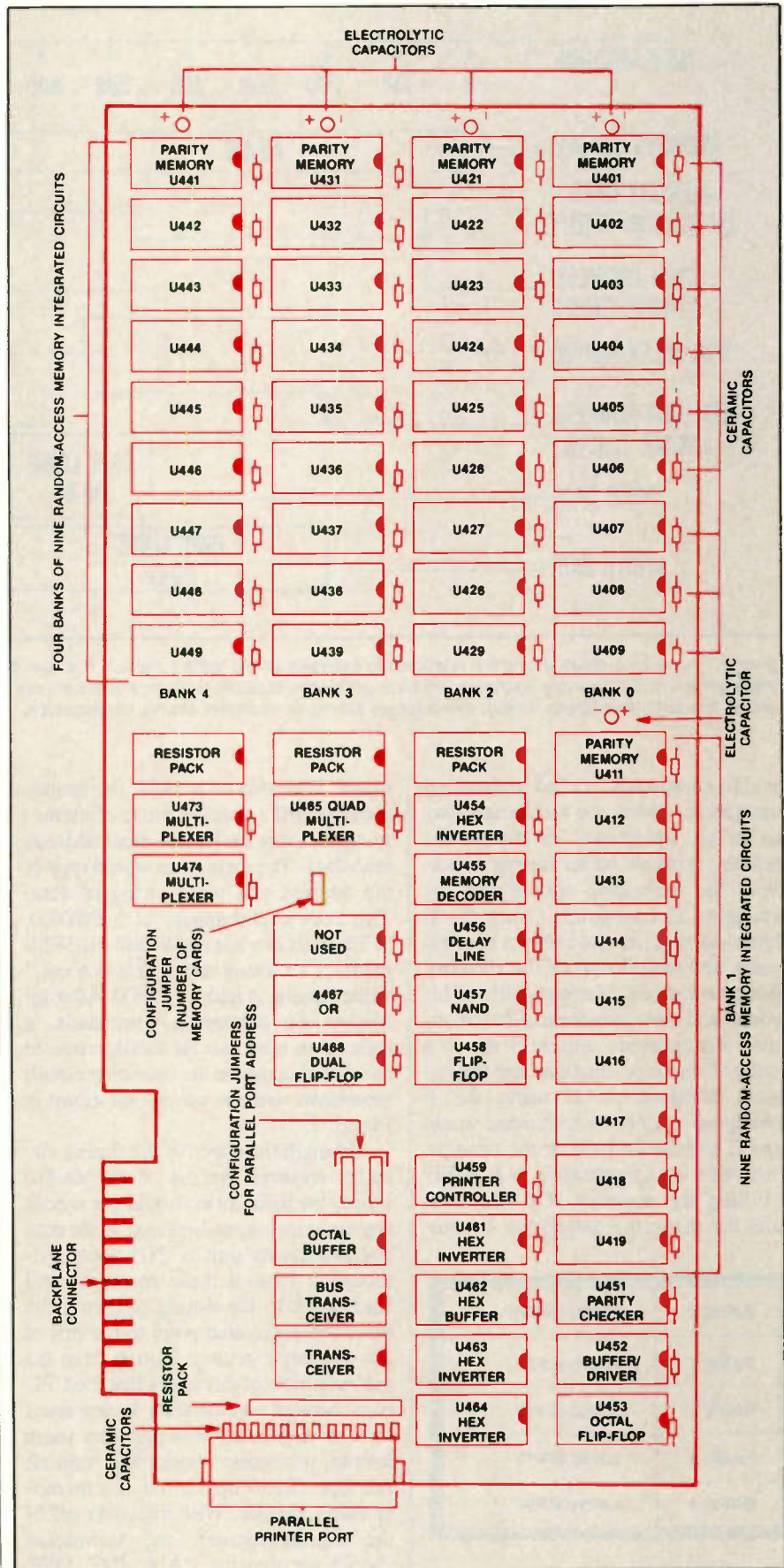

Figure 1. Using the card edge connector of the memory card as a logical starting point, you can trace the +5Vdc and ground lines throughout the memory card.

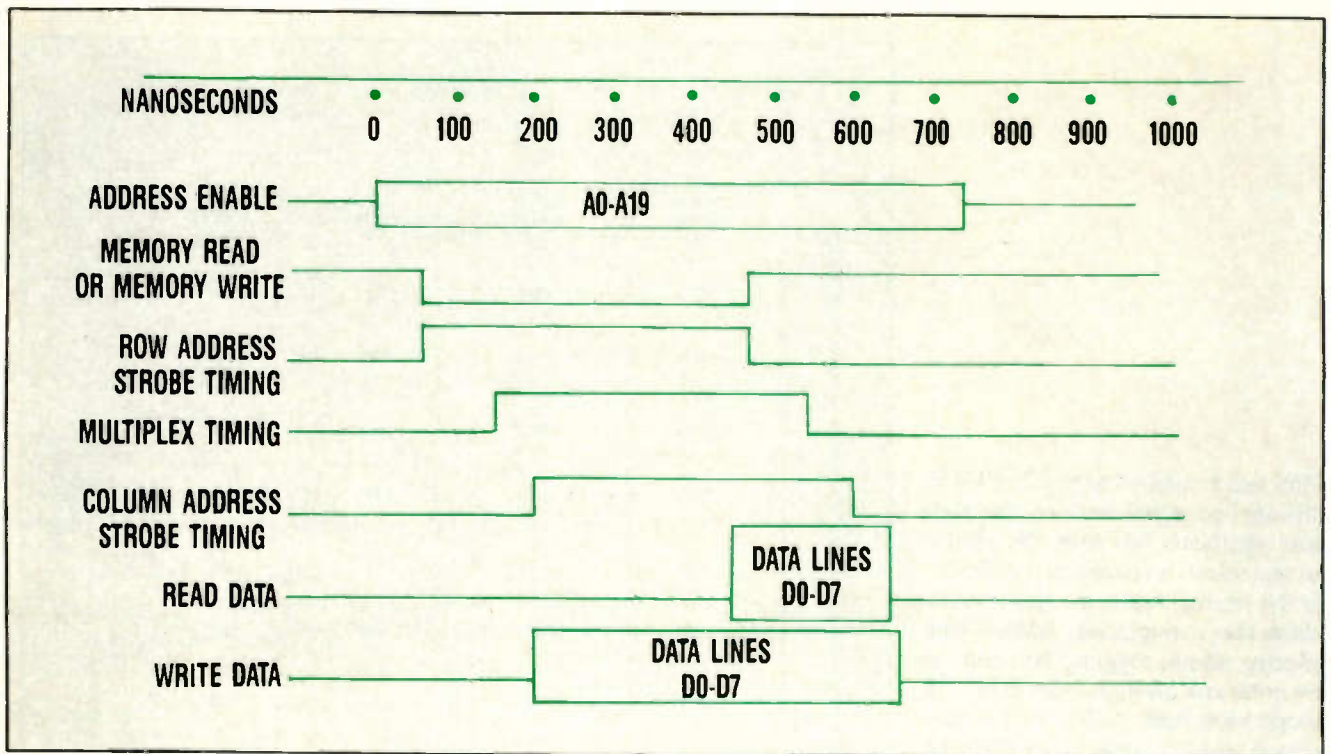

Figure 2. This timing chart shows the relationship between all the timing signals. If a flaw occurs in the timing sequences, the memory-access portion of the memory operation will have problems. Multiple problems with memory access suggest that a problem has occurred in either the column-address timing, row-address timing or multiplex timing relationships.

special commands, called *debugging* commands, which the technician may use to his advantage. To change the memory contents under testing conditions, the technician should use the debugging E command. Using the E command requires the use of a specific syntax and knowledge of the memory address locations. Memory address locations will have hexadecimal-based numeric designations. Figure 3 shows a listing of memory locations and the numeric designations. If using the E debugging routine, the technician would type E and the address at the prompt. This code would appear as >E 3FFF.

Filling the memory ICs with data calls for using the debugging F com-

BANK 0	00000-0FFFF
BANK 1	10000-1FFFF
BANK 2	20000-2FFFF
BANK 3	30000-3FFFF
BANK 4	40000-4FFFF

Figure 3. This listing shows the memory locations and hexadecimal-based numeric designations.

mand. With this command, the technician may fill a specific range of memory, again using the hexadecimal address, with data. The technician would type F, the address and some string of data. This code would appear as >F1800:0,3FFF. This is a test and would fill 3FFF memory locations with "This is a test," while starting at address 18000. After initiating the debugging commands, a technician may use an oscilloscope to check and compare the operating circuit waveforms with the waveforms shown in Figure 2.

Although the check of the timing circuitry requires the use of an oscilloscope, the technician should not ignore any error messages displayed as the central processing unit (CPU) boots. Although a look at these messages still leads back to the timing circuitry, the error messages also point to the rest of the memory circuitry. Noting from the second article of this series that the CPU runs through routine tests during start-up, the technician will find that these simple, automatic checks will stop all microprocessor operations if a memory error appears. With the cover off of the microcomputer, the technician should see that the RAM, INT, DSK and RDY error indicator LEDs, located on the 150 series CPU card, remain

on. These error indicators give the first clue that a problem exists in the RAM. The technician may also see a memory address location, usually shown in hexadecimal code, displayed on the monitor. When we explore the final characteristics of RAM operation in the next article, we will take a penetrating look at finding a defective IC with the assistance of the error message and disk-based diagnostics.

Figure 4 shows a problem-solving flow chart for RAM error symptoms. As shown in the chart, a defective U455, a memory decoder, will cause the selection of incorrect RAM banks during the address operation. Again referring to the flow chart, notice that another addressing error affecting the same location in each bank may also appear. Suspect the multiplexing circuitry contained in U465, U473 and U474 if this problem arises. A lack of the column-address logic signal or CASGATE will cause the loss of the high-order address signals. Because U467, U468 and U469 supply the signals needed for CASGATE, the technician should center his attention on the OR gate, the dual flip-flop and the tri-state octal buffer. A defective tri-state data latch, U470, will cause the drop-out of data for any user memory. A faulty bidirectional data bus IC, U471,

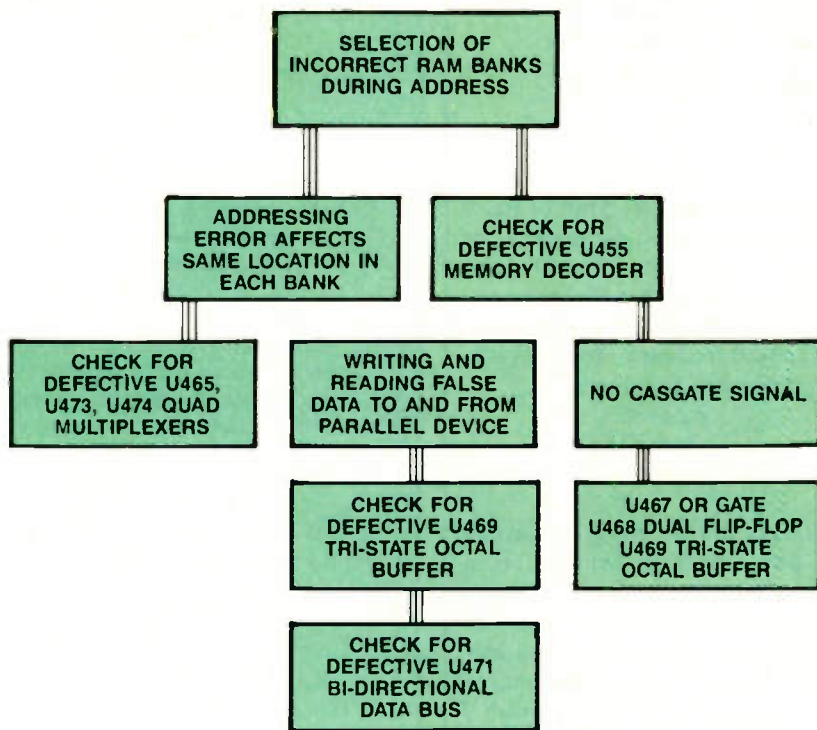

Figure 4. This problem-solving flow chart for random-access memory error symptoms shows some of the likely problem components for certain common errors.

generally will cause the writing or reading of false data by some device, such as a printer, connected to the parallel interface. If a data dropout occurs and the tri-state data latch passes all tests, the technician should check pin 1 of U471 with an oscilloscope. A low digital signal tells the technician that the attached parallel device has sent data onto the bus. A high digital signal shows that the bus has sent data to the device.

Moving through these diagnostics and typical symptoms for the timing circuitry leads the technician closer to the heart of the memory card — the random-access ICs. Everything we have learned about the peripheral circuits on the memory card should come into focus. In Part VI, we will conclude this look at the workings of the memory card with an examination of the RAM operation, a description of parity and an in-depth study of the role that disk-based diagnostics can play in troubleshooting memory circuits. We will also take another look at the interaction between the memory circuits and equipment fastened to the output ports of the micro-computer. ■

MCM ELECTRONICS



MCM Electronics is a broadline distributor of electronic products used in the repair of Television, Stereo, VCR, Computer and Camcorder equipment. We also offer an extensive line of original Japanese semiconductors from manufacturers such as Hitachi, Matsushita, NEC, Sanyo, SanKen and Toshiba.

MCM stocks replacement parts from many top suppliers...Pioneer and Pyle speakers, Audio Technica audio accessories, Cambridge connectors, Switchcraft plugs and jacks, Littelfuse fuses, Leviton electrical accessories, Eveready batteries and more. We are also an authorized distributor of RCA/GE replacement parts and Semiconductors!

Why not make MCM your electronic distributor? For a one-year subscription to our catalogs call TOLL-FREE at 1-800-543-4330.



MCM ELECTRONICS
650 CONGRESS PARK DR.
CENTERVILLE, OH 45459-4072
A PREMIER Company

ES-49

Circle (26) on Reply Card

THE BEST DEGAUSSER FOR CRTS



Lightweight, handy, easy to operate. This is a most effective demagnetizer for video screens, computer monitors, measuring tools, dies, tool-bits, cutting tools, etc. Correlative magnetic flux generation: 6.3V. Consumption: 3.3A. Continuous Service Hr: 2.5 Minutes. Weight: 1 Lb. Size: 1.25" x 1.24" x 8".

Send for your FREE Catalog today.

TECHNI-TOOL Inc.

5 Apollo Road, P.O. Box 368
Plymouth Meeting, PA 19462 U.S.A.
(215) 825-4990 Telex 83-4763
Fax. No. 215-828-5623

Circle (25) on Reply Card

Answers to the quiz

Questions are on page 19.

1. B — IC/IE. Alpha is obtained with the transistor in the common-base configuration. Therefore, of interest are the collector and emitter currents.

2. B — Not correct. The current gain of an emitter follower can be quite high but the voltage gain is less than one.

3. 24V. The circuit shown is a summing amplifier. It will add the 2V and 4V inputs to produce an output of 6V in an amplifier that has a gain of one. However, this amplifier has a gain of 4 obtained by dividing the feedback resistor (10kΩ) by the input resistance (2.5kΩ). Therefore, the output voltage is 6×4, or 24V.

4. The common base amplifier can be used to match a low impedance to a high impedance. This configuration is more often used for high-frequency amplifiers.

5. This is an ordinary bridge rectifier problem. The ratio of x to the adjusting resistor is the same as the ratio of the 20kΩ to 16kΩ resistor. An easy way to look at this is that 20kΩ is 1.25 times greater than 16kΩ. Therefore, x must be 1.25 times greater than 48kΩ. That makes x=60kΩ.

6. 100Hz. (See Figure 7.) The hori-

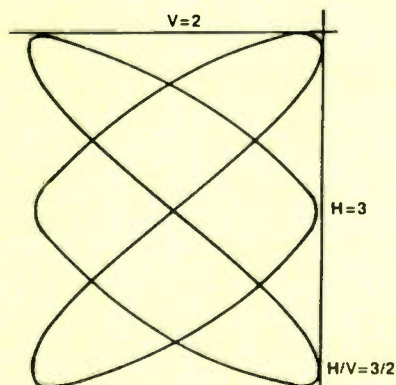

FIGURE 7

zontal line shows the limit of travel on the vertical axis; the vertical line shows the limit of travel on the horizontal axis. Note that the horizontal frequency must be 3/2 multiplied by the vertical frequency. You can make a simple ratio as follows:

$$\begin{aligned} 3/2 &= 150/x \\ 3x &= 300 \\ x &= 100 \end{aligned}$$

7. I know you are going to consider this a trick question, but think about it. You know A and B are both correct choices. Therefore, choice D would have to be correct. You may not have known that human bone is piezoelectric, but it has to be true if both A and B are true. If you stress a bone to the point where it is near breaking, it produces a voltage. This voltage may be used to produce a pain signal in the brain. It tells you to stop stressing your arm or leg or it's going to break.

8. This is an AND circuit. If either A or B (or both) is at logic 0, then the output will be at logic 0. (Disregard the voltage drop across the diode.) However, if A and B are both at logic 1, there will be no voltage drop across the resistor and the output voltage will also be at logic 1.

9. When the silicon diode is heated, its conductivity increases. Another way of saying that is there will be more current flowing through the diode for a given voltage. For that reason, characteristic curve X would correspond to a higher temperature.

10. In the relay diagram, the circled letters represent coils. The relay contacts are in series, showing that one pair is normally open and the other pair is normally closed. If one of the switches is closed and the other is open, there is no complete path through the lamp, and the lamp is off.

Symcure guidelines

ES&T is now paying \$60 per page for accepted Symcure submissions.

The term *Symcure* is a contraction of two words: symptom/cure. Problems that are published in the Symcure department are those that have occurred more than once. This is the kind of problem you can solve without even a second thought because you've already seen so many of that particular brand and model of set with those symptoms. In almost every case, it will be the same component that fails or the same solder joint that opens. Submissions must follow these rules:

- Each submission must consist of seven individual symptom/cure units on a single brand of TV set.
- If there is no Sams Photofact on the unit, we cannot accept the submission.

Troubleshooting Tips guidelines

ES&T is also paying \$25 per item for accepted Troubleshooting Tips.

A Troubleshooting Tip describes a procedure used to diagnose, isolate and correct an actual instance of a specific problem in a specific piece of equipment. Its value, however, lies in the general methods described.

A good Troubleshooting Tip has the following elements:

- It should be a relatively uncommon problem.
- The diagnosis and repair should present something of a challenge to a competent technician.
- It should include a detailed, step-by-step description of why you suspected the cause of the problem and how you confirmed your suspicions—anything that caused you to follow a false trail also should be included.
- It should describe how the repair was performed and any precautions about the possibility of damage to the set or injury to the servicer.

For Symcures and Troubleshooting Tips, please also include:

- the manufacturer's name;
- the model and chassis number;
- the Sams Photofact number;
- a sketch of the schematic area where the fault was found. (Include a major component such as a transformer or transistor to provide a landmark.)

ZENITH CM-140/DIGITAL(C) MAIN ENHANCED BLOCK DIAGRAM

Product safety should be considered when component replacement is made in any area of a receiver. Components marked with a ! designate sites where safety is of special significance. It is recommended that only exact cataloged parts be used for replacement of these components. A lightning bolt designates the presence of uninsulated, dangerous voltage.

Use of substitute replacement parts that do not have the same safety characteristics as recommended in factory service information may create shock, fire, excessive x-radiation or other hazards.

This schematic is for the use of qualified technicians only. This instrument contains no user-serviceable parts.

The other portions of this schematic may be found on other Profax pages.

(Note: The CM140/DIGITAL(C) chassis is similar to the CM140/DIGITAL(A), but with Bose and Premium Sound sound circuitry. The CM140/DIGITAL(A) chassis is used for models SE2035H/SE2733H/SE2733H2/SE2735P/SE2735P2/SE2791W/SE2791W2/SE2795W/SE2795W2/SE3133W.)

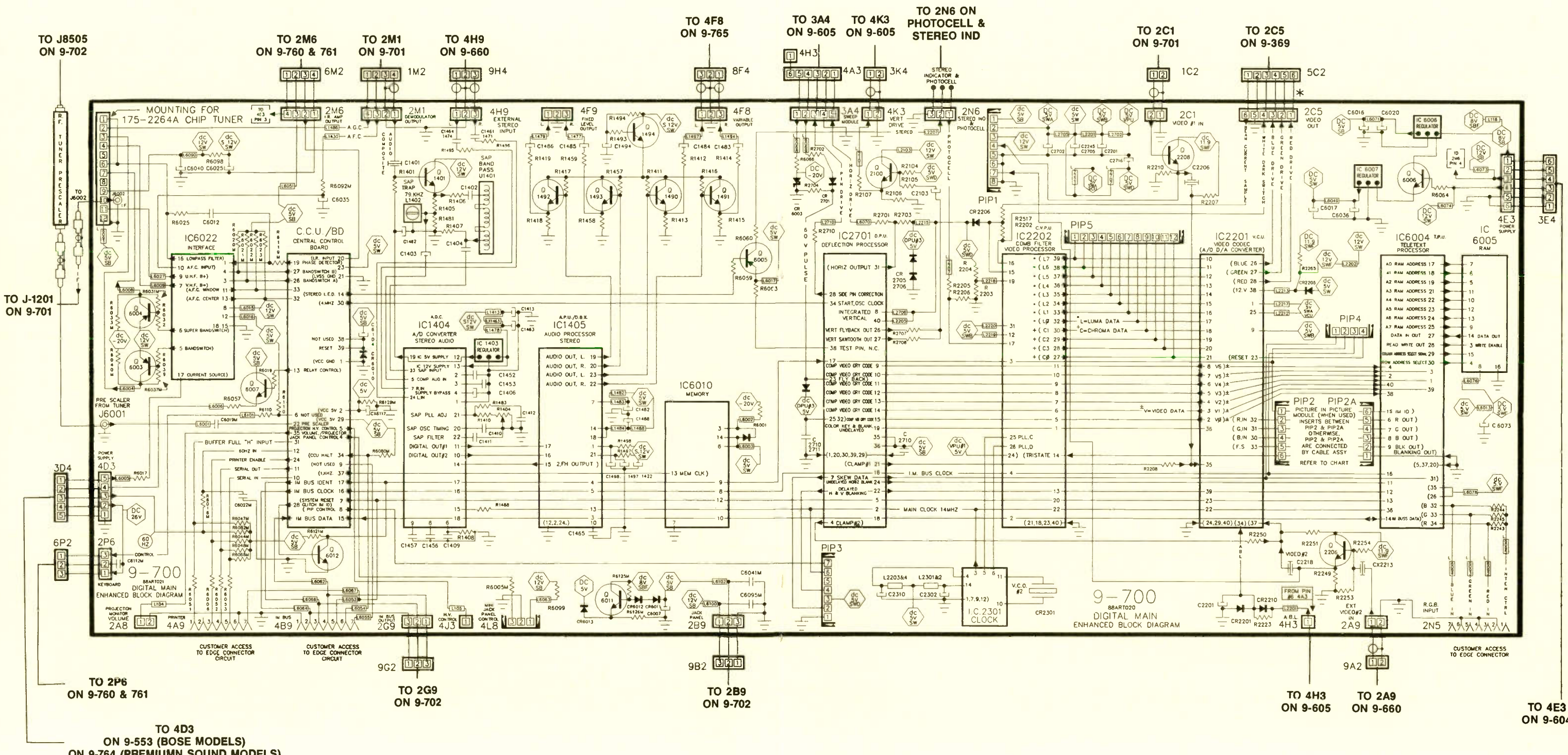

ZENITH CM-140/DIGITAL(C) SOUND CIRCUITRY

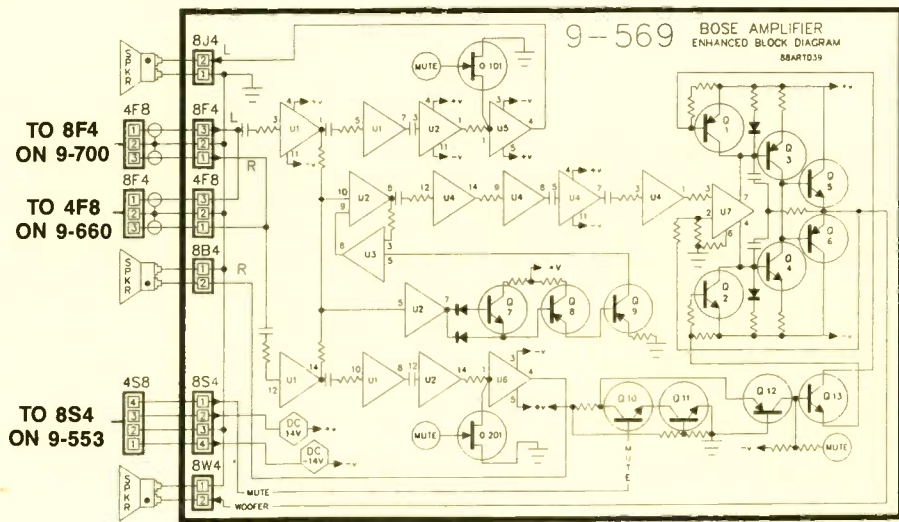
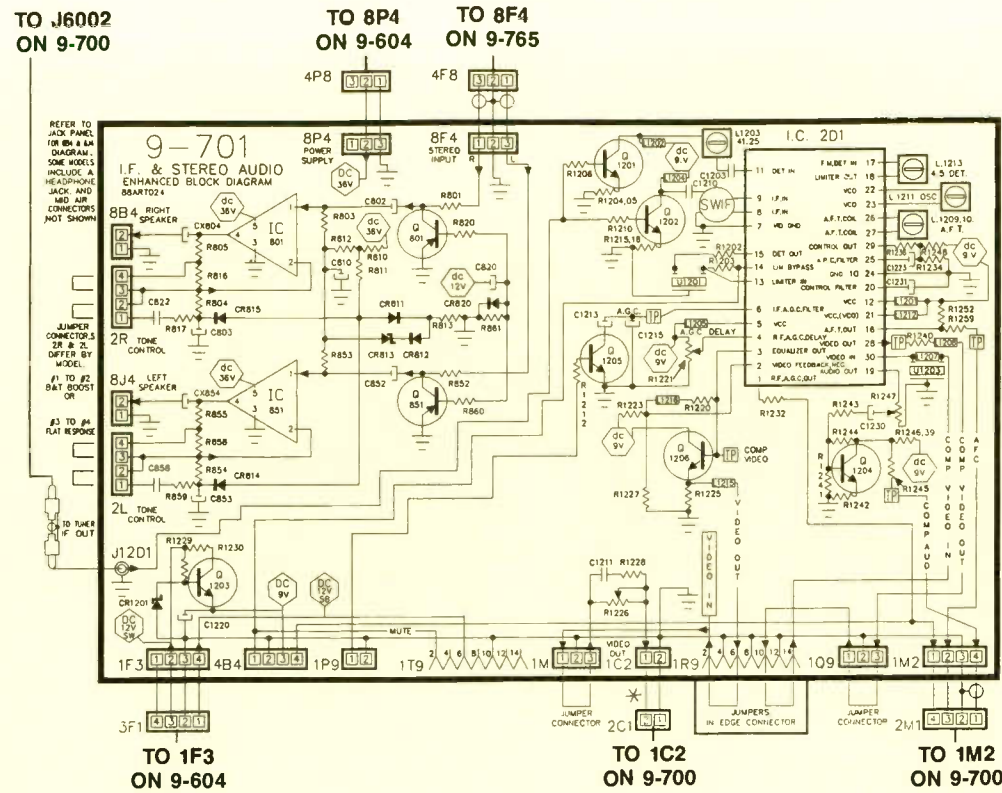

Reprinted by permission of Zenith Video Tech Corporation Copyright 1989, Electronic Servicing & Technology, P.O. Box 12901, Overland Park, KS 66212.

ZENITH CM-140/DIGITAL(C) SOUND CIRCUITRY

Product safety should be considered when component replacement is made in any area of a receiver. Components marked with a ! designate sites where safety is of special significance. It is recommended that only exact cataloged parts be used for replacement of these components. A lightning bolt designates the presence of uninsulated, danger-

ous voltage.

This schematic is for the use of qualified technicians only. This instrument contains no user-serviceable parts.

The other portions of this schematic may be

found on other Profax pages.

Use of substitute replacement parts that do not have the same safety characteristics as recommended in factory service information may create shock, fire, excessive x-radiation or other hazards.

Reprinted by permission of Zenith Video Tech Corporation Copyright 1989, Electronic Servicing & Technology, P.O. Box 12901, Overland Park, KS 66212.

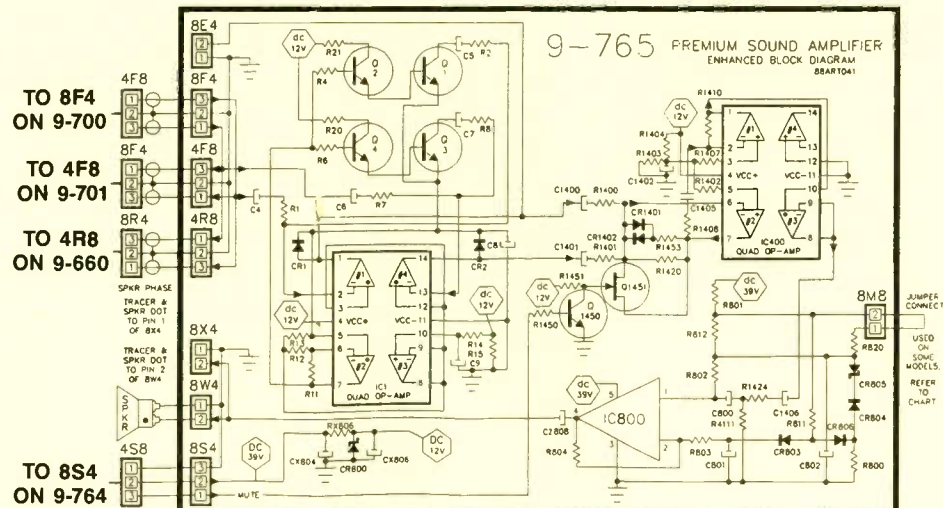
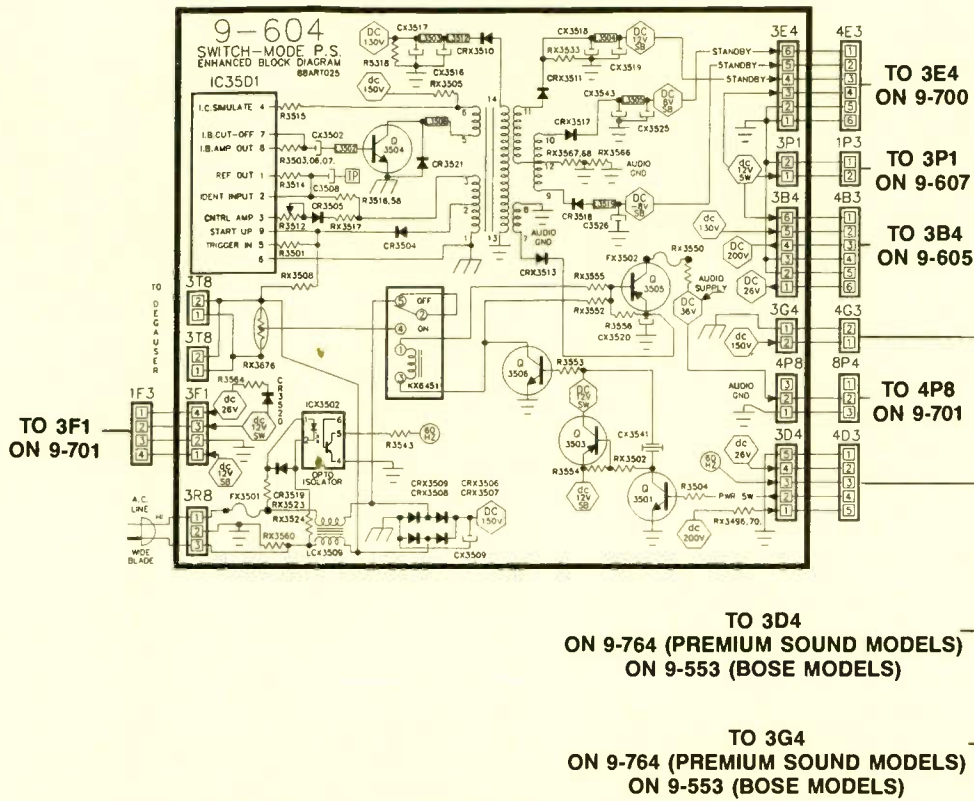

"PREMIUM SOUND" MODELS USE 9-765 & 9-764 MODULES

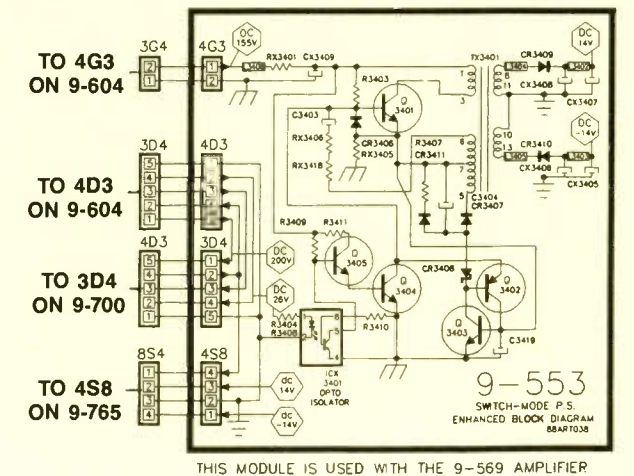
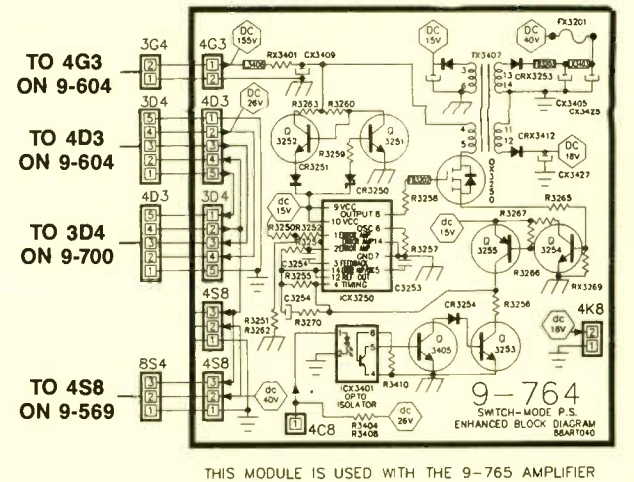
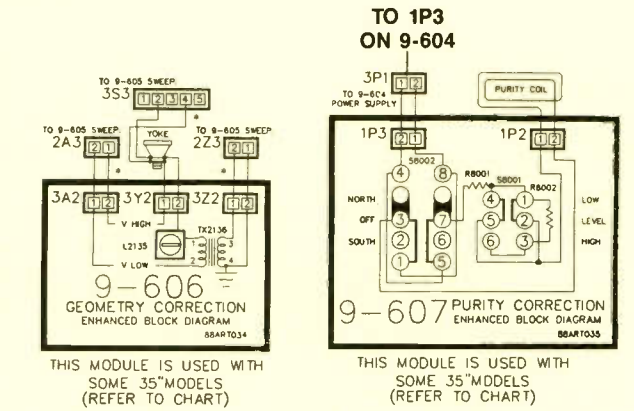

THIS MODULE IS USED WITH THE 9-569 AMPLIFIER

**ZENITH CM-140/DIGITAL(C)
RF AND VIDEO/AUDIO SELECTORS**

Product safety should be considered when component replacement is made in any area of a receiver. Components marked with a ! designate sites where safety is of special significance. It is recommended that only exact cataloged parts be used for replacement of these components. A lightning bolt designates the presence of uninsulated, dangerous voltage.

Use of substitute replacement parts that do not have the same safety characteristics as recommended in factory service information may create shock, fire, excessive x-radiation or other hazards.

This schematic is for the use of qualified technicians only. This instrument contains no user-serviceable parts.

The other portions of this schematic may be found on other Profax pages.

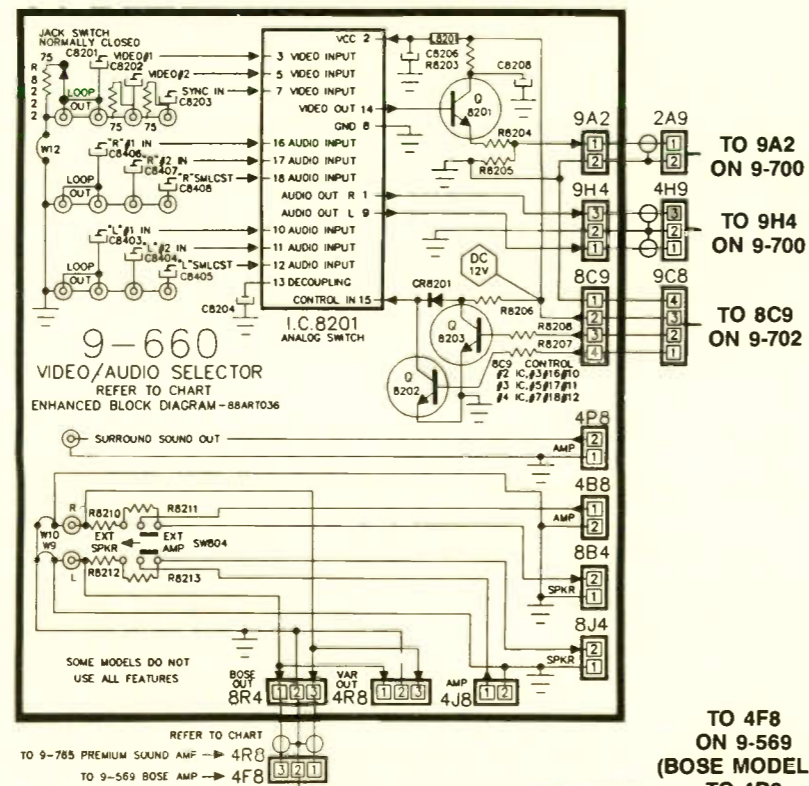
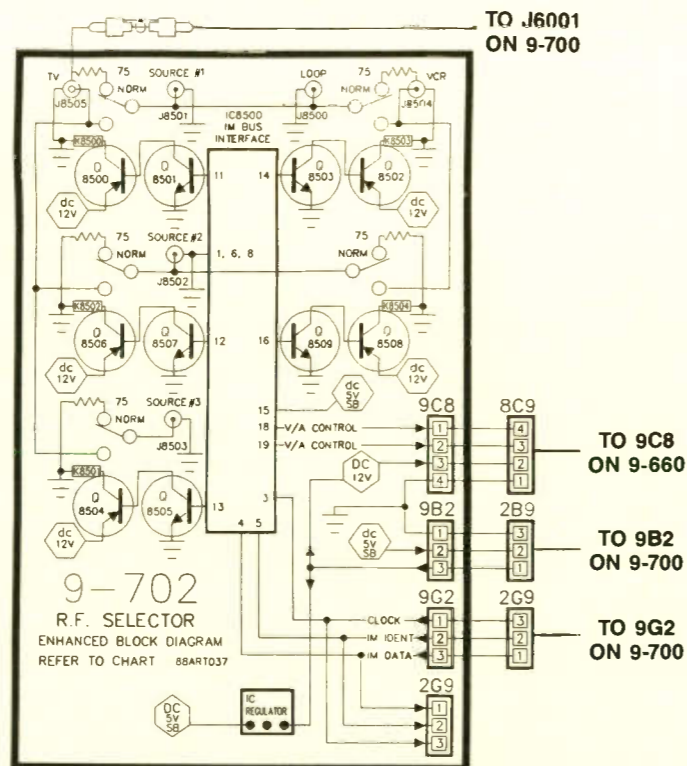

NOTE
9-700 CHASSIS USES SEVERAL INTEGRATED CIRCUITS WHICH ARE PLUG-IN (REFER TO CHART)

KEY TO SYMBOLS USED

- DC D.C. VOLTAGE SOURCE
- DC D.C. VOLTAGE
- 0 C. GROUND
- A.C. GROUND
- WAVE FORMS (AT CONNECTORS)
- DIRECTION OF FLOW
- SB STANDBY
- SBF STANDBY FILTERED
- SW SWITCHED
- SWF SWITCHED FILTERED

**ZENITH CM-140/DIGITAL(C)
WAVEFORMS**

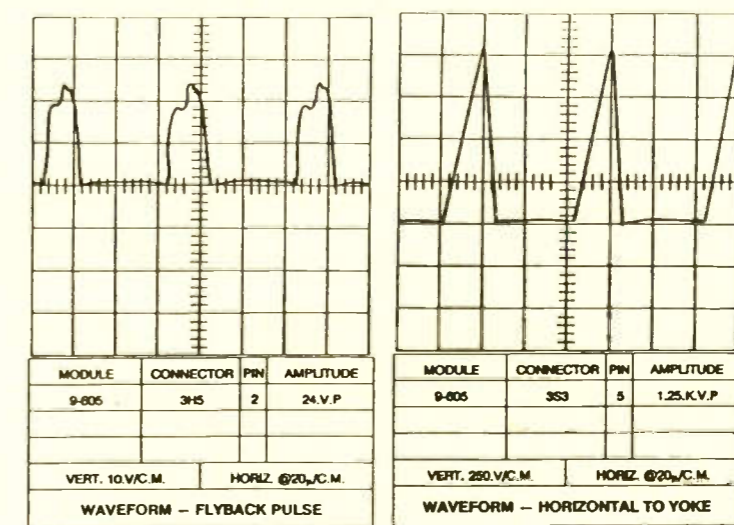
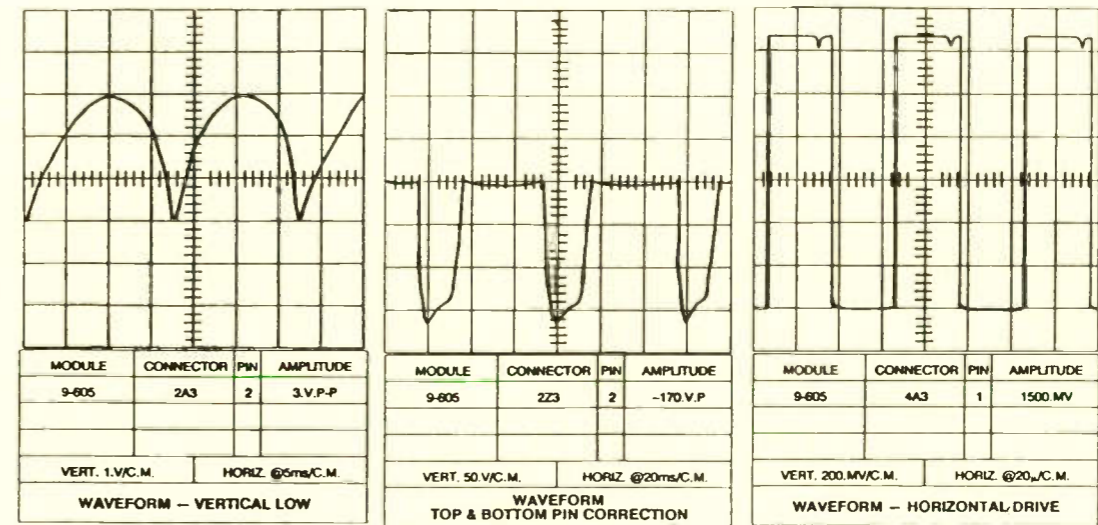
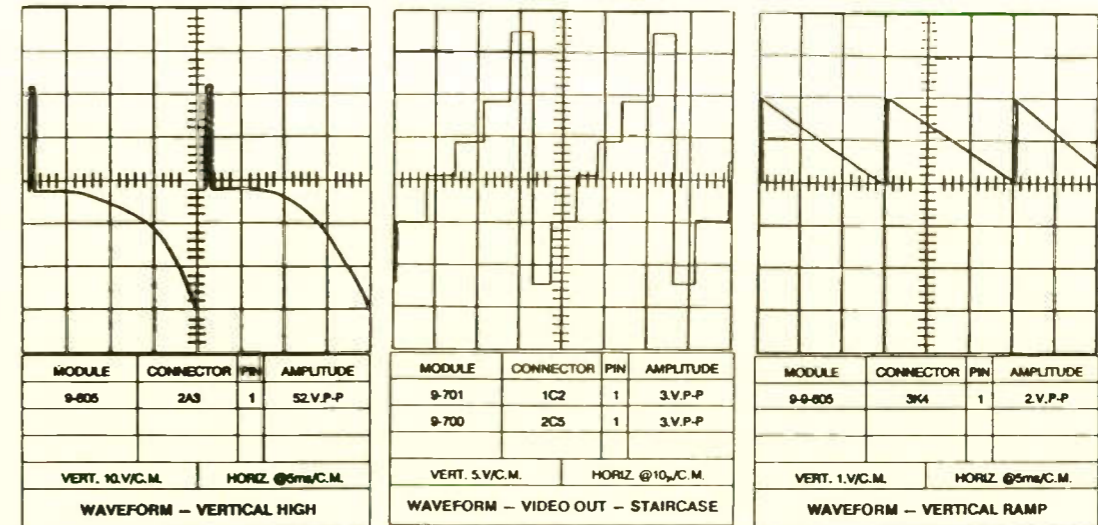

**ZENITH CM-140/DIGITAL(C)
VIDEO CIRCUITRY**

Product safety should be considered when component replacement is made in any area of a receiver. Components marked with a ! designate sites where safety is of special significance. It is recommended that only exact cataloged parts be used for replacement of these components. A lightning bolt designates the presence of uninsulated, danger-

ous voltage.

This schematic is for the use of qualified technicians only. This instrument contains no user-serviceable parts.

The other portions of this schematic may be found on other Profax pages.

found on other Profax pages.

Use of substitute replacement parts that do not have the same safety characteristics as recommended in factory service information may create shock, fire, excessive x-radiation or other hazards.

Reprinted by permission of Zenith Video Tech Corporation
Copyright 1989, Electronic Servicing & Technology, P.O. Box 12901, Overland Park, KS 66212.

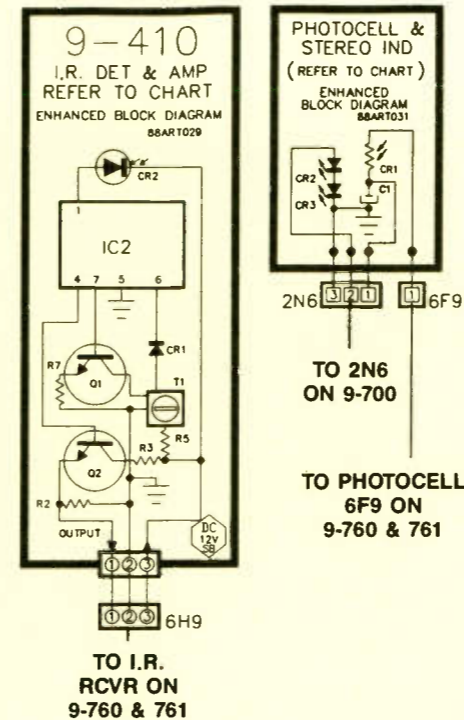
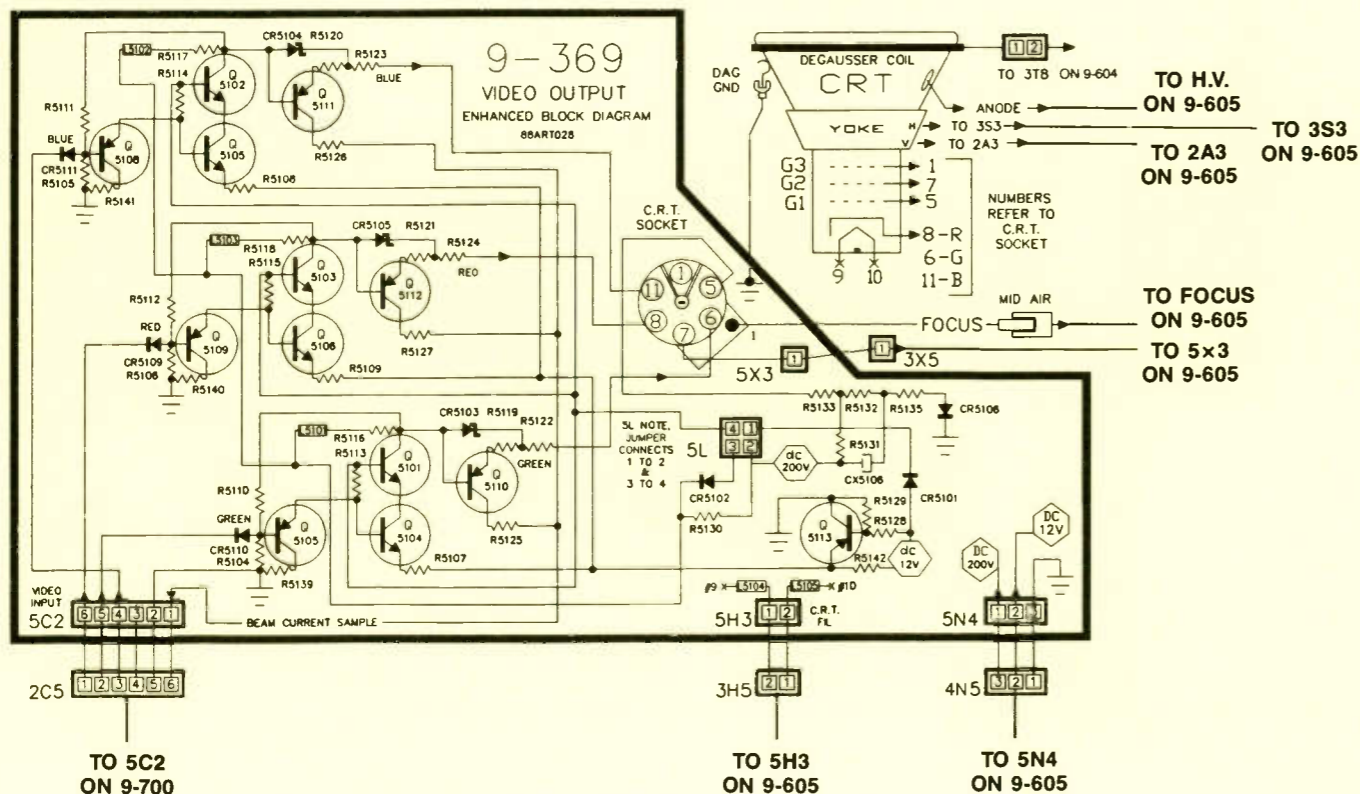
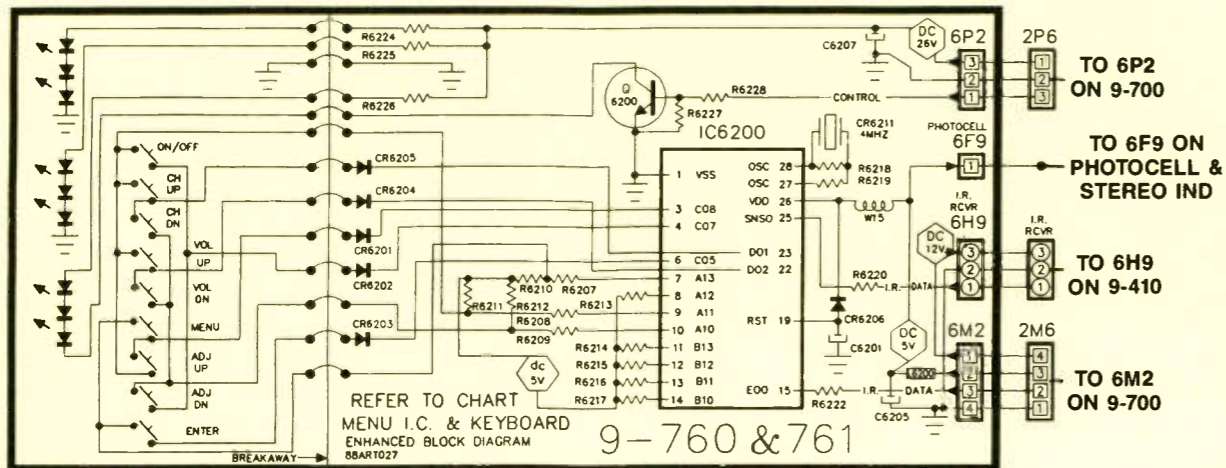

Product safety should be considered when component replacement is made in any area of a receiver. Components marked with a ! designate sites where safety is of special significance. It is recommended that only exact cataloged parts be used for replacement of these components. A lightning bolt designates the presence of uninsulated, dangerous voltage.

Use of substitute replacement parts that do not have the same safety characteristics as recommended in factory service information may create shock, fire, excessive x-radiation or other hazards.

This schematic is for the use of qualified technicians only. This instrument contains no user-serviceable parts.

The other portions of this schematic may be found on other Profax pages.

DECEMBER 1989

PROFAX
NUMBER

ZENITH
CM-140/DIGITAL(C) chassis digital
direct-view color TV receiver..... 3059
(Models SE3135P/SE3191H/SE3535H/ZB2771H/
ZB2771H2/ZB2777H/ ZB2777H2/ZB2797P/ZB2797P2/
ZB2797Y/ZB2797Y2/ZB3193H/ZB3193Y/ZB3539T/ ZB3539Y)

Reprinted by permission of Zenith Video Tech Corporation
Copyright 1989, Electronic Servicing & Technology, P.O. Box 12901, Overland Park, KS 66212.

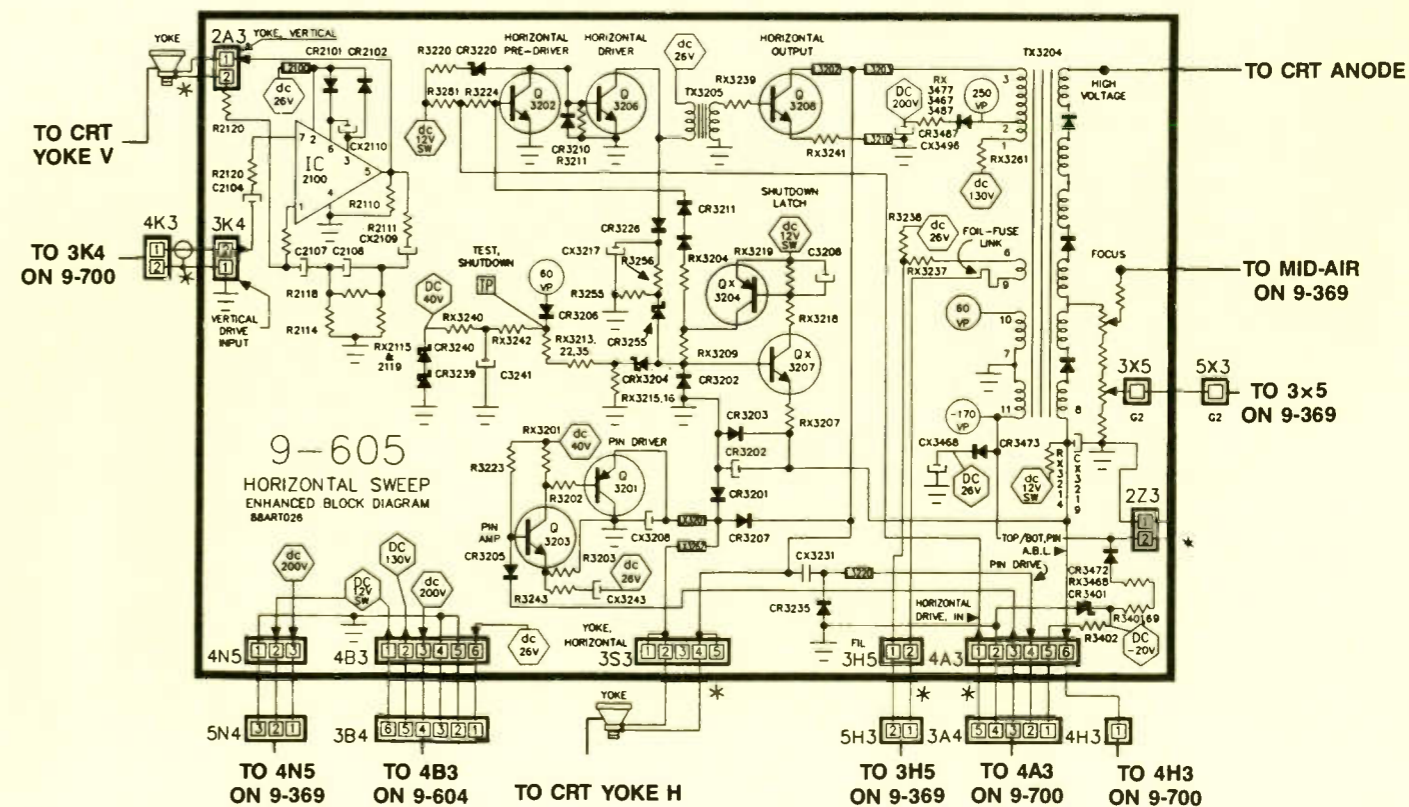

The computerized library

GE's prototype information-retrieval system not only reads information, but it understands what it reads and answers questions.

By drawing on artificial intelligence techniques, GE Research and Development Center scientists have taught a computer the rudiments of how to read and digest a variety of printed texts, and then to understand and answer questions about what it has read.

To demonstrate the potential of their computerized information-retrieval system, now in the laboratory prototype stage, GE researchers have applied it to a business problem — the task of helping a financial magazine keep track of daily happenings in the fast-moving field of acquisitions and mergers, as reported by the press.

In this demonstration, the GE information-retrieval system was fed a day's worth of stories (about 500 items in all) transmitted by a financial news service. It automatically picked out those dealing with mergers and acquisitions and stored them in terms of the concepts with which they dealt.

At that point, the GE researchers were able to ask the system such questions as "Who received an offer from Bethlehem Steel?" and "What was offered for DTS?" The system responded with short, accurate answers. Questions and answers were phrased in plain English, not computer language.

The system can potentially be adapted to operate in vernacular versions of other languages, such as French and German.

GE's research points toward the day when computers will be able to quickly scan and digest mountains of written information, providing data on demand that will help people make decisions faster and more intelligently.

Understanding concepts

The basic tool in the GE research program is a software package known as SCISOR (System for Conceptual Infor-

mation Summarization, Organization and Retrieval). Built on advanced natural language-understanding concepts, it was designed by Lisa F. Rau and Paul S. Jacobs, computer scientists at the GE Research and Development Center. The system has a lexicon of 10,000 words.

Conventional search systems can look for key words but cannot answer questions. If the system finds a key word, it can only reprint the news story the word appears in. SCISOR, by contrast, can answer questions and provide digested summaries of topics.

Potential applications of this technology include almost any area in which human beings under intense deadline pressure have to struggle through smothering amounts of paperwork. Examples include financial management, requisition engineering, marketing and national defense.

A major part of this research is focused on devising software programs that permit computers and people to interact in natural language. That goal may not be reached for several decades. Working toward it, however, will gradually reduce the language barrier between users and computers, thereby opening computerized information to a growing audience.

"In the distant future, we can imagine the computer not as a static repository of information but as a librarian who not only knows where all the information in the library is kept, but also has read and understood everything in the library," Rau explained. "Our work rests on the belief that a truly helpful information-retrieval system must, in some sense, understand what the user is looking for."

How the system works

In GE's prototype system, the raw material for tracking a takeover or merger comes from a syndicated financial

news wire, which is routed directly into the researchers' computer, an engineering workstation. A component known as the *topic analyzer* is programmed to act as a gatekeeper, admitting stories that involve potential or actual mergers and takeovers and turning away others.

The news wire stories admitted by SCISOR's topic analyzer are fed into a software system known by the acronym TRUMP (for TRansportable Understanding Mechanism Package), which comprehends the English prose in which the news reports are written. TRUMP tries to understand just what each story is reporting, in terms of such factors as who is planning to take over whom, the value of the share prices offered, and the target company's acceptance or rejection of the offer.

Another component of SCISOR, known as the *integration mechanism*, is programmed to recognize fresh facts in each new story and to add those facts to SCISOR's existing store of knowledge about that particular takeover.

Categorizing information

The system understands and categorizes the information that reaches it by analyzing it in two distinct ways: bottom-up and top-down parsing.

In bottom-up parsing, the system builds up the meaning of the prose by diagramming sentences in junior-high-school English style. That approach runs into trouble when the system encounters unknown words, such as names, and ambiguous language, which is common in natural English. A naive machine could take the phrase "a tender offer" to indicate a kinder, gentler approach to business negotiations.

Top-down parsing aims to grab pieces of the meaning by using expectations built into the knowledge base — for ex-

Continued on page 57.

Troubleshooting varactor tuners – Part II

By Stephen J. Miller

In Part I of this series (see the November issue), we covered varactor tuning systems in general and the voltage synthesis tuning system in depth. This month we will delve into the mysteries of the frequency synthesis tuning system. Phase locked loop (PLL) tuning is another common name for frequency synthesis tuning.

The PLL system

The mysterious PLL tuning system is actually closely related to a familiar circuit, the horizontal AFC circuit. Figure

Miller is a senior bench technician for a Lancaster, PA, repair company.

1 shows a block diagram of the horizontal automatic frequency control (AFC) circuit. In the phase comparator, the horizontal sync pulses are compared to sample pulses from the horizontal sweep circuit. If any frequency or phase error exists between the two inputs, the phase comparator will output a correction signal. This error signal is filtered into a dc voltage by the low-pass filter and then applied to the horizontal voltage-controlled oscillator (VCO). Thus the AFC section will provide any necessary correction to ensure that the horizontal sweep section remains in exact synchronization with the transmitted signal.

Figure 2 shows a simplified block di-

agram of a PLL tuning system. In place of the sync input, a crystal oscillator is divided down to produce an accurate and stable reference signal. The only major difference between this diagram and the horizontal AFC circuit is the addition of a variable frequency divider in the VCO feedback line. This variable frequency divider block allows the tuning system to change channels by varying the divide ratio of this block. For example, assume that the divide ratio is initially set at 1 (the frequency of the VCO equals the reference frequency). If the divide ratio is changed to 2, the inputs to the phase comparator will differ in frequency and the phase comparator will output an error signal that will shift the frequency of the VCO to twice that of the reference frequency. Thus the VCO's frequency can be varied in discrete frequency steps, the value of each step being equal to the reference frequency.

In a PLL tuning system, the VCO is the local oscillator inside the tuner, and the variable frequency divider is controlled by the microprocessor. When the customer changes channels, the microprocessor will reprogram the frequency divider to the value corresponding to the desired channel. Because of the large frequency difference between its

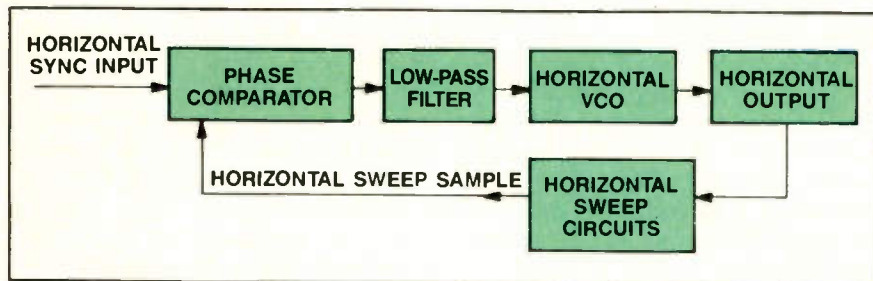

Figure 1. The horizontal automatic frequency control (AFC) circuit provides any necessary correction to ensure that the horizontal sweep section remains in exact synchronization with the transmitted signal. In the phase comparator, the horizontal sync pulses are compared to sample pulses from the horizontal sweep circuit. If any frequency or phase error exists between the two inputs, the phase comparator will output a correction signal. This error signal is filtered into a dc voltage by the low-pass filter and then applied to the horizontal VCO.

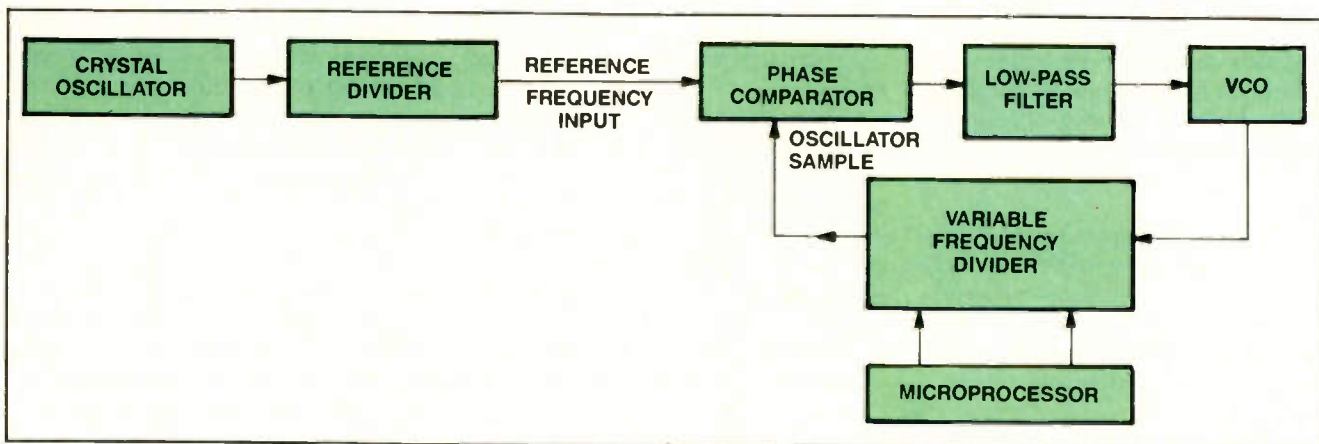

Figure 2. In place of the sync input, the PLL tuning system uses a crystal oscillator divided down to produce an accurate and stable reference signal. A variable frequency divider in the VCO feedback line allows the tuning system to change channels by varying the divide ratio of this block.

inputs, the phase comparator outputs a large error signal, which forces the VCO toward the desired frequency. As the VCO approaches the desired frequency, the magnitude of the error signal diminishes to zero and the tuning system locks onto the new channel. Once the PLL tuning system locks onto the channel, it will accurately track the VCO and make the corrections necessary to maintain the desired frequency.

Usually the PLL IC contains the programmable divider, phase comparator and reference oscillator circuits. Digital data, pertaining to the channel requested, is transmitted from the microprocessor to the PLL IC. Some tuning systems use a dual-function microprocessor in which one chip performs both the microprocessor and the PLL functions.

Modifications

Although the circuitry in Figure 2 will produce a working PLL tuning system, it is usually modified to be more economical. Because high-frequency devices are also high-cost, a prescaler divide circuit is often placed inside the tuner to divide or *prescale* the local oscillator signal by a fixed amount. By reducing the frequency of the oscillator sample, the programmable divider can be constructed of less expensive, slower logic circuits.

A major drawback of adding a prescaler is that the minimum frequency step of the VCO is increased. The frequency step is equal to the reference frequency times the prescaler value. Too high a frequency step can lead to inaccurate fine-tuning of channels and difficulties in tracking channels, especially offset carrier cable channels. To overcome these problems, designers have two options: lower the reference frequency or add an additional circuit called *pulse swallow control* (PSC).

Pulse swallow control uses a prescaler that can be switched between two different divide ratios. A PSC line connects the microprocessor to the prescal-

er circuit. This control line instructs the prescaler as to which divide ratio to use. A computer program inside the microprocessor produces a specific pulse train on the PSC line to minimize the frequency step, along with other parameters, for the particular channel requested.

Some of the latest tuning systems incorporate the prescaler and PLL circuits into one IC, making the circuit simpler and easier to service. Figure 3 is an example of such an IC. Notice that the prescaler and pulse swallow circuitry are internal to the IC. Serial tuning data is input on pin 3. A clock signal, on pin 4, synchronizes the serial data transfer. After the proper data is loaded into the shift register section, a latch pulse loads the data from the shift register to the data latch. Because the internal data latch stores the tuning data, serial data transfer occurs only when a channel change is requested. All three signals (data, clock and latch) must be present for data transfer from the microprocessor to the PLL IC. A 4MHz oscillator, generated from the crystal connected to pins 6 and 7, supplies the reference signal to the phase comparator. The phase comparator output exits the IC on pin 9.

Troubleshooting

In troubleshooting PLL tuning systems, follow the flowchart in Figure 4. If the tuner operates with the diagnostic device (see the sidebar "Building a Servo Diagnostic Device" in Part I) installed, verify that a sample of the local oscillator is reaching the programmable divider. This signal level varies with different tuning systems. Some prescaler output signals are several volts peak-to-peak, while others are only a few millivolts peak-to-peak. For example, the RCA CTC140/148/149 series of chassis have a peak-to-peak amplitude of 0.5V. For accurate information on how much signal is correct, consult the service manual. If a signal is observed, vary the diagnostic device and verify that the oscillator sample varies in fre-

Why order your parts from several parts houses? Order them from your all-in-one parts distributor.



MARYLAND

1306 Continental Drive
Abingdon, MD 21009-2334

Parts Order Desk Only:

1-800-638-3328

Research and Information:

1-301-676-7300

*FLORIDA

1015 NW 52nd Street
Ft. Lauderdale, FL 33309

Parts Order Desk Only:

1-800-365-8030

Research and Information:

1-305-938-8030

**AUTHORIZED PARTS
DISTRIBUTOR FOR:**

SHARP *

SANYO *

FISHER *

RCA

PANASONIC

QUASAR

GE

TECHNICS

ALSO STOCKING

Large inventory of N.A.P. Parts
Sylvania • Philco • Magnavox

SAMS • CHEMTRONICS • RCA SK's

TRITRONICS

Circle (27) on Reply Card

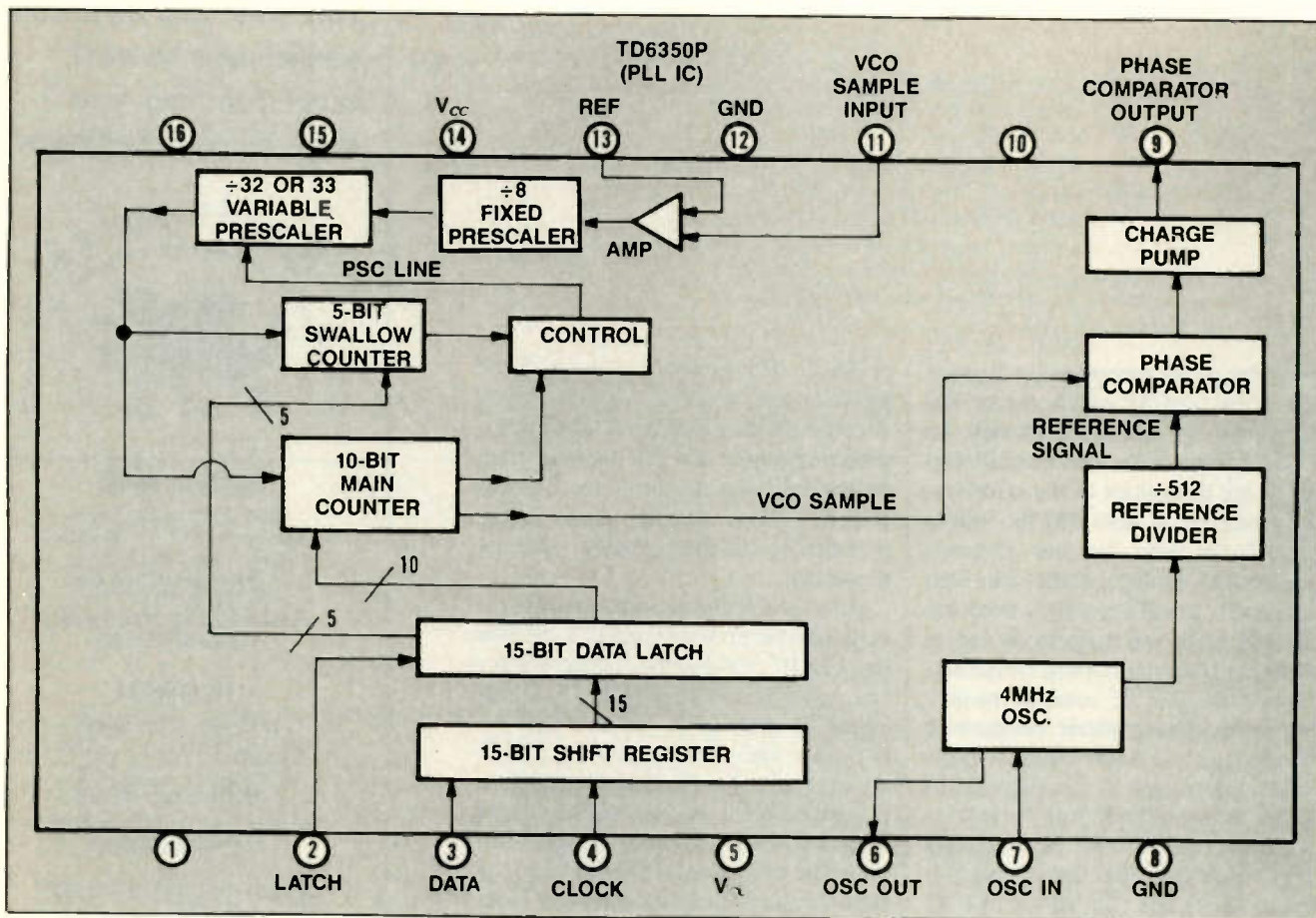

Figure 3. Some of the latest tuning systems incorporate the prescaler and PLL circuits into one IC, making the circuit simpler and easier to service.

quency. If the oscillator sample is of correct amplitude and varies in frequency, then the tuner itself is probably OK.

Problems with the PSC circuitry most often cause one of three symptoms:

- Channels are mistuned — a black-and-white picture or a herringbone pattern appear on-screen.
- Channels are not tuned in the correct location (channel 10 may be tuned when channel 9 is requested).
- The tuning system continually searches, adjusting the tuning voltage slightly above and then slightly below the correct point. This problem causes the picture to tear or flash.

In troubleshooting these symptoms, verify that the PSC signal exists right at the input to the tuner. (See Case History #1.) Some tuning systems do not generate a pulse swallow output signal for every channel. The tuning system in the RCA CTC140/148/149 chassis generates a pulse swallow output only for UHF and cable channels. To test the pulse swallow circuitry, connect the diagnostic device to the tuning voltage line. Tune in a channel with the device.

While monitoring the PSC line with a scope, enter a different channel number with the receiver's keyboard. The pulse train output should react by changing its frequency or number of pulses if the PSC circuitry in the microprocessor is OK.

PLL tuning-control systems have several inputs and two main types of outputs: the bandswitching output lines and the phase comparator output line. The bandswitching lines tell the tuner into which frequency band the desired channel falls. Loss of bandswitching signals will cause symptoms of no reception or reception on only certain blocks or bands of channels. Bandswitching circuitry often requires a negative voltage supply. Often the only load on this negative supply is the bandswitching circuits. Loss of this negative supply will therefore not affect the operation of any other section of the receiver. When it is used, always check the negative power supply to the bandswitching circuits. (See Case History #2.)

The phase comparator output line is a tri-state line. This line can output ei-

ther a HIGH, a LOW or a high-impedance state. The high-impedance state is used when the tuning voltage is precisely right and no correction is necessary. Once the tuning system has locked on a channel, the phase comparator output line is normally at the high-impedance state. If the frequency of the local oscillator begins to drift low, the phase comparator output will go low momentarily to raise the local oscillator's frequency back to normal. Conversely, if the frequency of the local oscillator goes too high, the phase comparator output will go high momentarily to lower the local oscillator's frequency back to normal.

To test the phase comparator output line, attach the diagnostic device to the VT terminal of the tuner, enter a channel number on the receiver's keyboard, then adjust the device until the particular channel you selected is received. This last step is very important. If you enter channel 6 on the keyboard, the device must be adjusted until channel 6 appears on the screen. Now attach the scope probe to the phase comparator

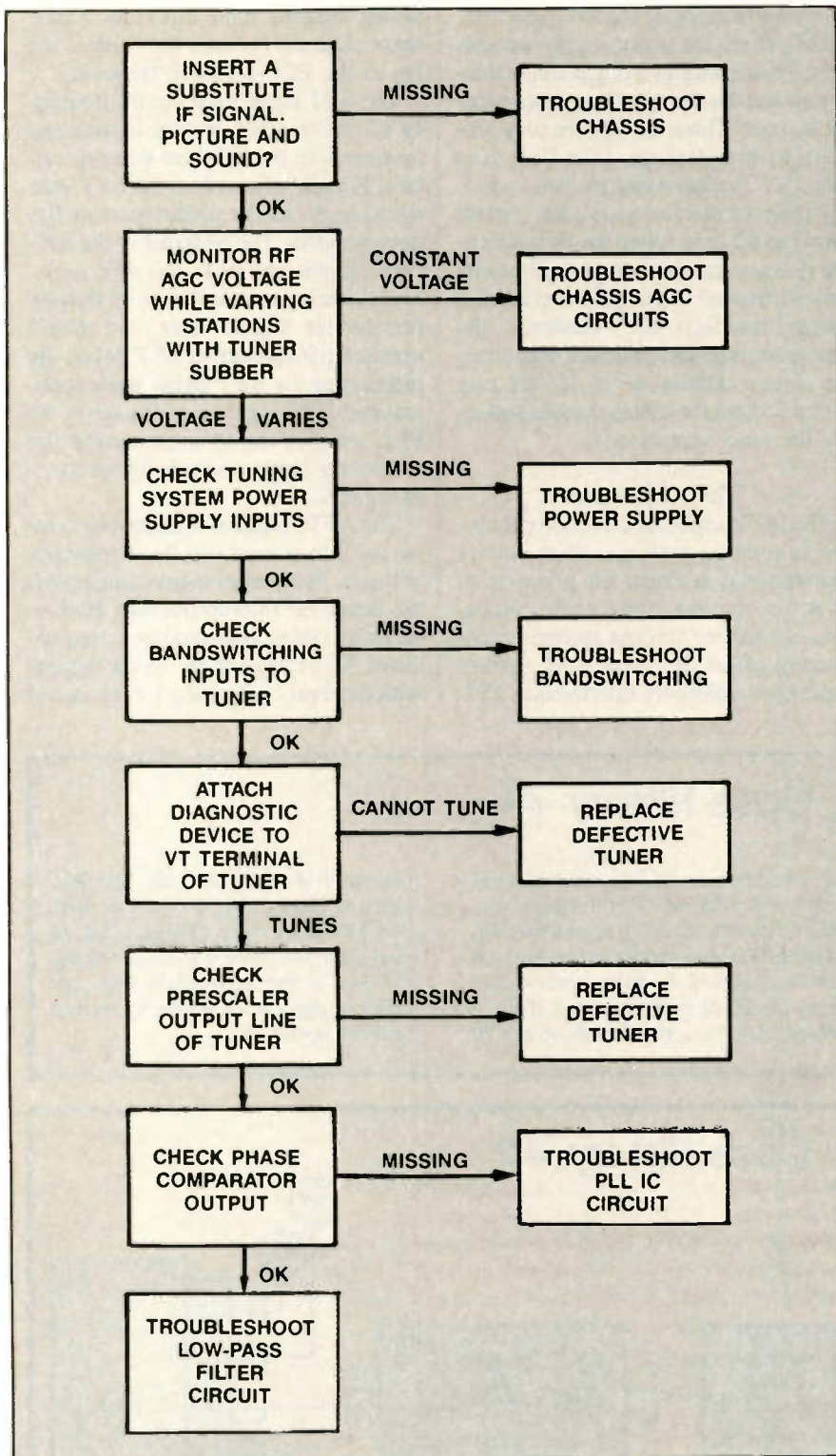

Figure 4. With PLL tuning systems, if the tuner operates with the diagnostic device, verify that a sample of the local oscillator is reaching the programmable divider. If a signal is observed, vary the diagnostic device and verify that the oscillator sample varies in frequency. If the oscillator sample is of correct amplitude and varies in frequency, then the tuner itself is probably OK.

output line. (Use a 1V per division scale and dc coupling.) While watching the scope, vary the diagnostic device. If the phase comparator output is OK, the scope's trace should vary between a high and a low as the device's control is ad-

justed back and forth through the correct tuning point. If this reaction is not seen, verify that the prescaler, master oscillator and digital data inputs are present before replacing the PLL IC. If the phase comparator output is correct,



VCR ALIGNMENT TAPE

This professionally mastered 15 minute alignment tape will prove to be an important addition to your repair equipment inventory. It will assist in the adjustment of the tape path and audio/control head alignment, head switching point, luminance and chroma circuit, and tracking fix. 30 Hz audio tone, gray raster, NTSC color bars, convergence grid and convergence dots. Great for TV alignment also.



#505-030

\$24⁹⁵

BATTERY ELIMINATOR

This handy adaptor eliminates the need for batteries when using your camcorder in your automobile. Simply insert the "dummy" battery pack into the camcorder and the lighter plug into the cigarette lighter jack of the vehicle. Your camcorder then draws its power from the car's electrical system. The lighter plug has a built-in 7 amp fuse to protect your camcorder from harmful current surges. Will replace our battery # 140-541. Call for more details.



#090-920

\$14⁹⁰

VCR IDLER KIT

Make VCR tire repairs quickly by having the tire you need in stock when you need it. This comprehensive kit contains 170 of the most commonly used tires in an easy-to-use case and a cross reference with over 80 manufacturer assembly numbers crossing to over 200 VCR model numbers. A \$400.00 retail value.



#400-900

\$55⁰⁰

VCR REPAIR PARTS KIT

Now you can do most of your VCR repair jobs the same day. Parts Express' VCR Parts Kit makes this possible. It contains over 45 of the most commonly used parts to repair RCA, Hitachi, Fisher, Sanyo, Lloyds, Panasonic, Sony, Sharp, JVC, Samsung, TMK, GE, Magnavox and more. Idler assemblies, pinch roller, sensing transistors, switches, and lamps are included in this comprehensive kit. You also save over \$20.00 (wholesale pricing). Call for more details.



#400-950

\$89⁹⁵

FREE CATALOG



CALL TOLL FREE
1-800-338-0531

340 E. First St., Dayton, OH 45402
Local: 1-513-222-0173

Circle (15) on Reply Card

the problem is most likely in the low-pass filter circuit.

Figure 5 shows two common low-pass filter circuits that can be used as inverting active low-pass filters. C2 and C3 provide negative feedback from output to input, which cancels out any ac signal components. These capacitors also act as charge-storage devices that maintain the output at a constant dc level when the input is in its high-impedance state. If the charge on C1 begins to bleed off, the input voltage to Q1 will decrease, which will cause the conduction of both Q1 and Q2 to decrease and raise the output voltage. The increase in output voltage will be fed back via C2 and C3 to replenish the charge in C1 and bring the circuit to its initial operating point. By outputting high correction pulses, the phase comparator can discharge C2 and C3 and reduce the output voltage. The opposite effect happens when the phase comparator outputs low correction pulses.

In troubleshooting the low-pass filter circuit, check the power-supply voltages first. Then carefully check both the transistors and the charge-storage capacitors for leakage. These circuits are very sensitive to stray leakage. (See Case History #3.) The latest designs are including most of the low-pass filter circuit inside an IC chip. Often the bandswitching drivers and the low-pass filter circuit are housed in one chip and labeled "tuner interface IC." However, the charge-storage and feedback capacitors are always external to the IC. Be sure to check them for leakage before replacing the tuner interface IC.

The AFT input

The AFT input to the microprocessor is used to perform offset carrier searches and to detect the presence of an active channel. Some cable companies and master antenna systems intentionally offset the carriers of various channels to minimize interference. PLL

tuning systems have difficulty tuning these channels because the carriers are not at the FCC-assigned frequency.

The AFT signal indicates the frequency of the received picture carrier and originates in the IF/video detector circuit. Figure 6 shows how the AFT voltage changes as the picture carrier frequency varies. The midpoint of the AFT curve is referred to as the *AFT crossover point* because at that point the picture carrier "crosses over" the correct operating frequency of 45.75MHz. By monitoring the AFT signal while systematically altering the divide ratio of the PLL section, the microprocessor can accurately locate and tune offset carrier signals.

The AFT voltage is evaluated by comparing it to at least two fixed reference voltages. Sometimes these comparators are inside the microprocessor. However, many tuning system designs have external AFT comparators. In the designs with external comparators, there are at

Case History #1

A Capehart TV, model 1990ARO, arrived for service with a complaint that it had a poor picture. On the test bench, the set displayed a distorted black-and-white picture with a lot of herringbone. Also, some channels were not tuned in the correct slots. For example, channel

10 would be received when channel 9 was requested. After verifying the power supplies, I checked the AFT input into IC101. The AFT input seemed to be correct. Next, I checked the pulse swallow control, pin 20 of microprocessor IC101. I observed a 5V_{p-p} signal both on pin 20

and pin 2 of connector P103. The PSC signal is carried over a coax line from plug P103 to the tuner. Disconnecting the coax from the tuner, I checked the signal level at the input to the tuner and found no signal at all. Replacing the coax restored operation.

Case History #2

Only some superband channels could be received on a Zenith SB2523G6. Power-supply voltages enter the 9-442 controller module on connector 6K3. After taking some voltage readings, I discovered that pin 4 of this connector was incorrect — the -30V supply was missing. Following the circuit back to the main module, I found R3468 open and CR3472 shorted. Replacing these components repaired the set. Figure A shows a simplified diagram of the circuit. Notice the transformer winding is on the 9-187 module, the -30V rectifier and filter are on the 9-214 module, and the remainder of the bandswitching circuitry is on the 9-442 module. With bandswitching circuitry spread out over several modules, blindly replacing a module is unlikely to repair the set. However, with a little troubleshooting, the cause can be quickly determined.

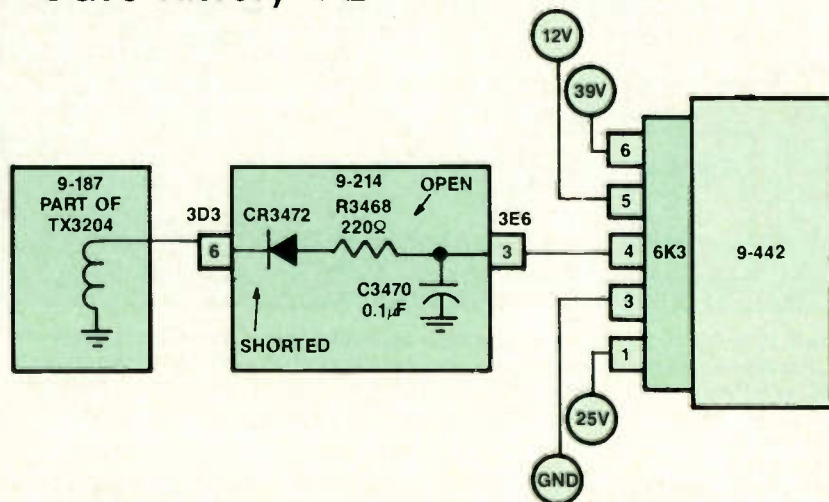

Figure A. When bandswitching circuitry is spread out over several modules, blindly replacing a module is unlikely to repair the set. In this schematic, the transformer winding is on the 9-187 module, the -30V rectifier and filter are on the 9-214 module, and the remainder of the bandswitching circuitry is on the 9-442 module.

Case History #3

No channels could be received on a TMK 1933RC, although the channel LED could be varied. Tuner substitution verified that no problem existed in the chassis. Voltage checks also ruled out any power-supply problems. Attaching the diagnostic device to the tuning voltage line

of the tuner, I proved that the tuner was OK. Scoping pin 22 of IC101 while varying the diagnostic device resulted in a normal output from the phase comparator. Therefore, the problem must be in the low-pass filter, the circuit between pin 22 and the tuner. (See Figure B.) After

making careful leakage checks, I found that C114 had $3k\Omega$ of leakage. Replacing this tantalum capacitor completed the repair.

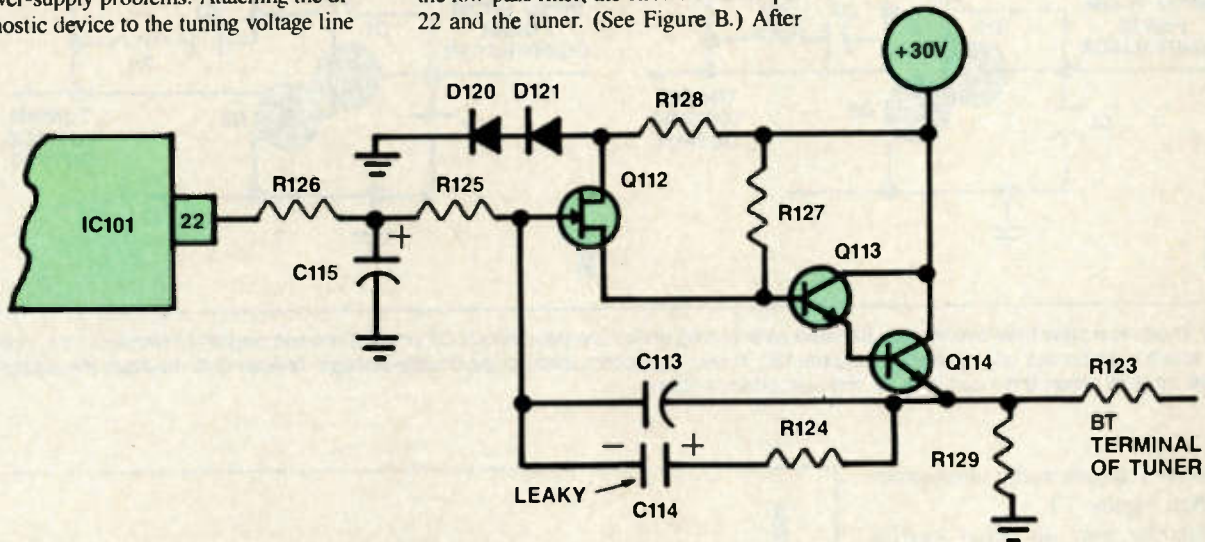

Figure B. When no channels can be received and chassis, power-supply and tuner problems are ruled out, scope pin 22 of IC101 while varying the diagnostic device. If normal output is verified from the phase comparator, the problem must be in the low-pass filter, the circuit between pin 22 and the tuner.

Come Out of the Dark.

Light Up
your business with
"current" news from
the NESDA Update, a bi-monthly
newsletter of events that affect your
business. For information about NESDA,
and a free sample of the Update, just mail
the following to NESDA:

Name _____

Address _____

City _____ State _____

Zip _____

Phone _____

National Electronic Sales &
Service Dealers Association
NESDA

2708 W. Berry St.
Ft. Worth TX 76109
(817) 921-9061

One of a series.

Presenting an affordable Light Box System.

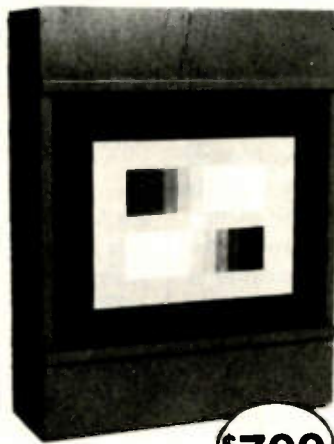

\$799

The method most
manufacturers recommend

Model TR100 CB
Camera Light Box
with (2) transparencies

- (2) 3200° Kelvin Lamps (meets mfr. spec.)
- 1-year conditional guarantee
- Transparencies mounted in acrylic with optical scratch-resistant surface
- 11-step gray scale transparency
- 7-Bar color transparency
- All orders are shipped within 72 hours, U.P.S.

NOTRONIX (313) 939-2740



P.O. Box 77103 • Sterling Hts., MI 48077



Circle (16) on Reply Card

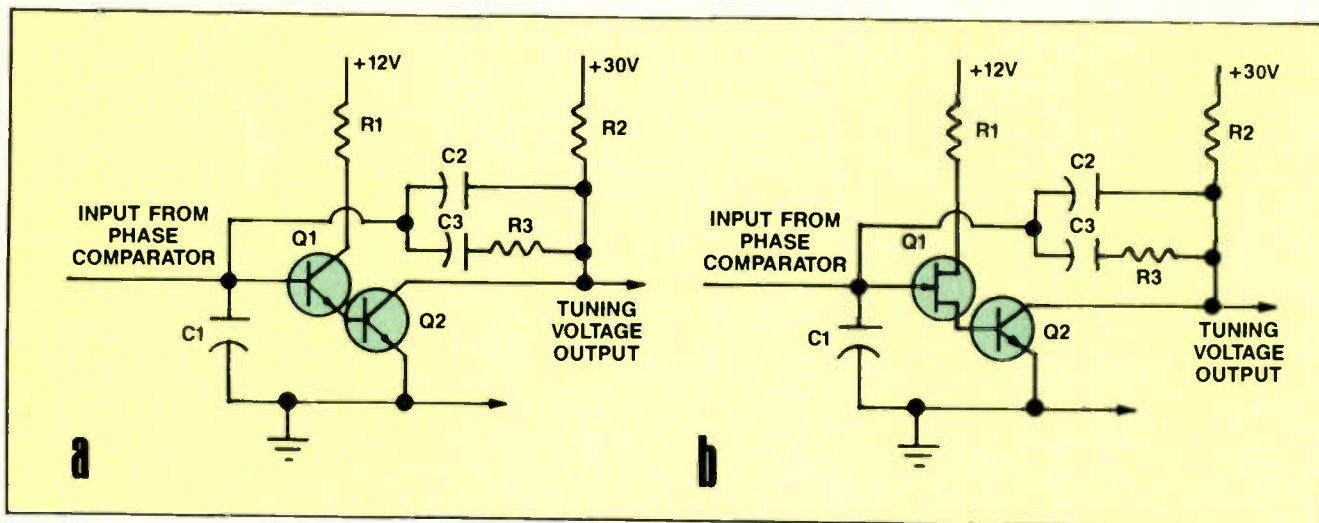

Figure 5. These low-pass filter circuits can be used as inverting active low-pass filters. C2 and C3 provide negative feedback from output to input, which cancels out any ac signal components. These capacitors also act as charge-storage devices that maintain the output at a constant dc level when the input is in its high-impedance state.

least two AFT inputs to the microprocessor. (See Figure 7.)

To illustrate how an offset carrier search operates, consider the GE 8-1445. In this chassis, IC701 performs both the microprocessor and PLL functions. The AFT input is pin 13 and the AFT comparators are internal to IC701. Upon changing channels, IC701 sets the tuner to a frequency 2MHz below the FCC-assigned frequency. While monitoring the AFT input, IC701 then increases the local oscillator in 240kHz steps. After the AFT voltage drops below 3.3V, IC701 switches to smaller, 40kHz steps. Once the AFT voltage drops below 2.3V, IC701 stops increasing the local oscillator frequency and starts decreasing it in 40kHz steps. When the AFT voltage again exceeds 2.3V, IC701 stops searching and maintains the local oscillator at that frequency until the next channel change. Figure 8 illustrates the search procedure.

IC701 will scan a channel from 2MHz below to 2.24MHz above the picture carrier. If, after four passes through this frequency range, no AFT crossover is detected, one of two actions will be taken. If the channel change was initiated in the direct-access mode (the customer entered the desired channel number into the keyboard), IC701 will default to the FCC-assigned frequency for that channel. If the customer initiated the channel change with the channel-scan keys, IC701 will advance to the next channel.

Many receivers also have a sync input to the microprocessor. Some receivers use the sync input instead of

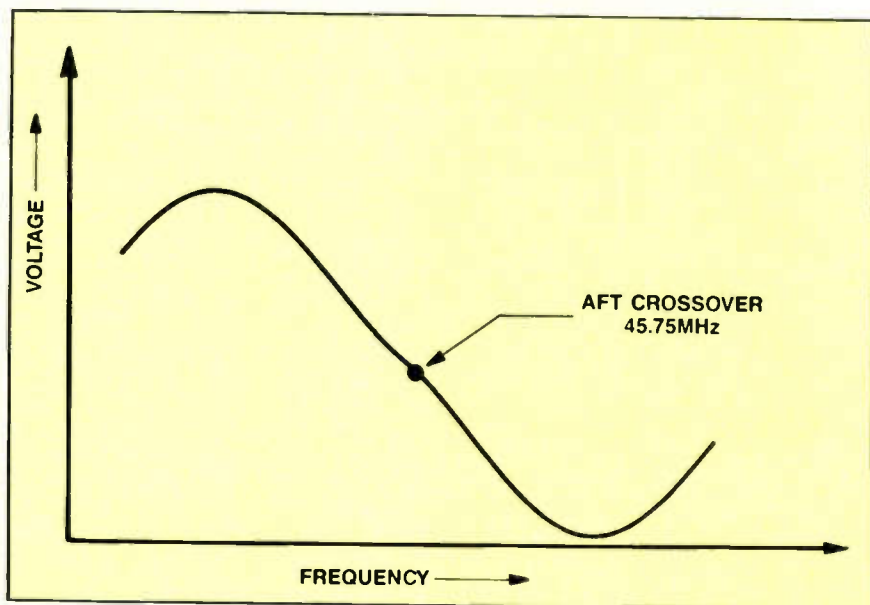

Figure 6. The AFT signal indicates the frequency of the received picture carrier. The midpoint of the AFT curve is referred to as the AFT crossover point because the picture carrier "crosses over" the correct operating frequency of 45.75MHz.

the AFT input to determine active channels. However, most often the sync input is used as a secondary check after AFT crossover has been detected. By checking for valid sync after AFT crossover has been detected, the microprocessor is less likely to be confused by a spurious signal.

Some receivers use an external circuit to convert the valid sync signal from an ac signal to a dc logic level before inputting this signal into the microprocessor. One method is to compare a sync signal and a flyback pulse in an AND circuit. The output of this AND circuit is then sent to the sync input port of the

microprocessor. Another name for this type of sync input is the *coincidence input*. A high signal on the coincidence input tells the microprocessor that both the sync AND the flyback pulse are present and in phase.

Figure 9 shows a common AND circuit. Q1 and Q2 are in series with the B+ line and both must be turned on simultaneously to supply B+ to R1 and C1. C1 filters the dc pulses into a constant dc level. If the drive signal to either transistor is missing or out of phase with the other, no voltage will be developed across C1. By monitoring the voltage on C1, the microprocessor can de-

tect when valid sync is present.

In receivers with channel-scan problems, difficulty with autoprogramming, or slow channel lockup, both the AFT and sync inputs signals should be verified. To check the AFT circuits, attach the diagnostic device and tune in a channel. If the tuning system constantly scans through all the channels, the diagnostic device will be unable to properly tune. For these cases, remove the IF line from the tuner and connect an external tuner subber to the IF line for this test. (See the sidebar "Building a Tuner Subber" in the November issue.) With a dc meter, monitor the AFT input to the comparators. The AFT voltage should correspond to the value given in the service manual, and it should swing above and below this operating point as the diagnostic device or tuner subber is fine-tuned slightly above and below the channel. If this voltage is incorrect, follow the AFT line back to the IF/video detector stage. (See Case History #4.) If this voltage is correct, follow the signal through the comparators to the microprocessor input(s).

The sync input line is verified by

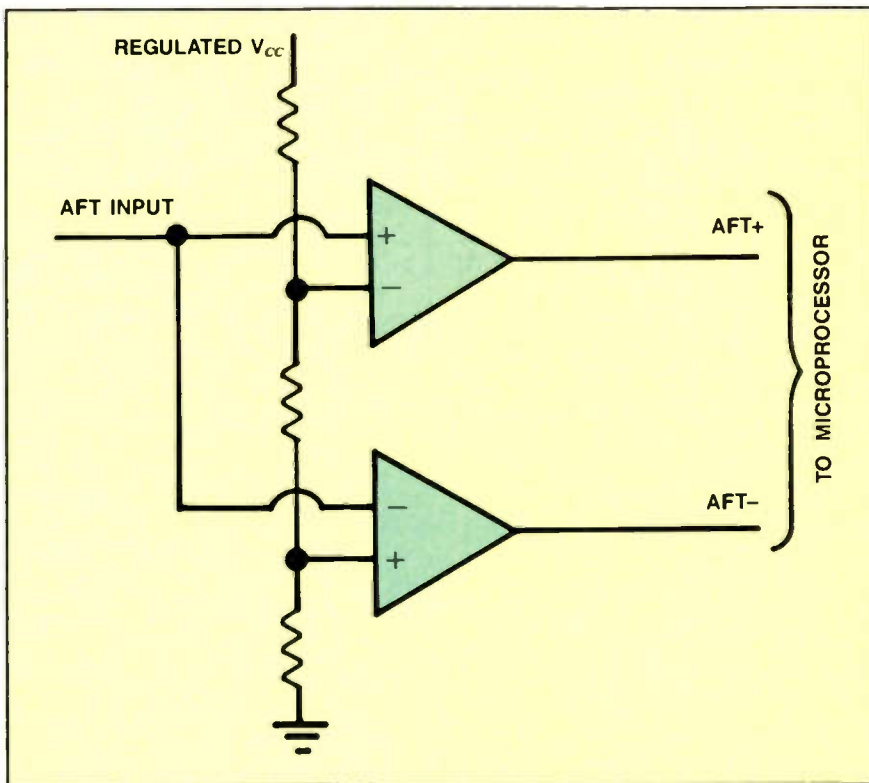

Figure 7. The AFT voltage is evaluated by comparing it to at least two fixed reference voltages. If the AFT comparators are external to the microprocessor, there are at least two AFT inputs to the microprocessor.

Moving?

TAKE US WITH YOU.

Just peel off your subscription mailing label and attach it to the address change card inside this issue. Please allow 6-8 weeks to process your address change.

Plug in!

To the NESDA system.

YOUR BUSINESS is in the world's fastest changing industry. If you're not careful, you could find your business in the dark.

But, you don't have to stay there.

Through a system of local, state, and regional groups, the National Electronics Sales & Service Dealers Assn. (NESDA) keeps members up-to-date with the fast pace of advancing technology while offering:

- ◆ Managerial and technical training.
- ◆ Business contacts.
- ◆ Technical and management certification.
- ◆ Information on new products.
- ◆ Legislative activities that affect the industry.

Don't be left in the dark. Let the NESDA system work **FOR YOU!**

For more information and an application, write to:
 NESDA, 2708 W. Berry St., Ft. Worth, TX 76109; Ph (817) 921-9061

Name _____

Bus. Name _____

Address _____

State _____ Zip _____ Phone _____

Member of State Local Assn. _____

monitoring its signal both with and without an active channel tuned in. The diagnostic device can be used for tuning during this test also. Most external sync detector circuits will place a high on the microprocessor input pin when an active channel is being received. When an inactive channel is received, the input pin should be pulled low. Always verify that this occurs.

New designs

The latest generation of tuning sys-

tems place the PLL and bandswitching circuitry inside the tuner. Digital data is sent from the microprocessor right into the tuner. This data instructs the tuner as to the specific channel requested. Figure 10 shows a typical pin-out for one of these tuners. In troubleshooting these tuners, three different types of tuner inputs must be checked.

First confirm the power supplies. Three different supplies are used. A +30V supply is used to generate the tuning voltage. The analog sections of

the tuner require a medium voltage supply, typically +12V. Finally, the digital sections require a +5V input. Be sure to verify all three supplies.

Next, verify activity on the digital pins. Digital data is commonly transmitted via a 3-line serial bus. This bus is made up of data, clock and latch lines. The clock input signal synchronizes the transfer of information from the serial data input to an internal shift register. Once the shift register is fully loaded, the latch pulse loads the data into memory. In troubleshooting these inputs, verify the signals on all three lines. Data transfer occurs only when a channel change is requested.

After a channel has been selected, the tuner uses the data stored in its memo-

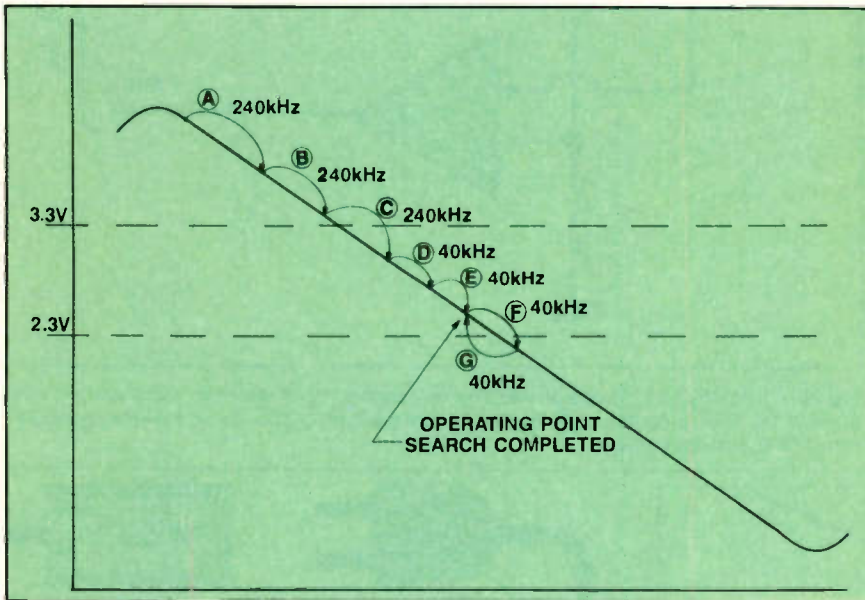

Figure 8. To change channels, the IC sets the tuner to a frequency 2MHz below the FCC-assigned frequency. While monitoring the AFT input, the IC increases the local oscillator in 240kHz steps. After the AFT voltage drops below 3.3V, the IC switches to smaller, 40kHz steps. Once the AFT voltage drops below 2.3V, the IC starts decreasing the local oscillator frequency in 40kHz steps. When the AFT voltage again exceeds 2.3V, the IC stops searching and maintains the local oscillator at that frequency until the next channel change.

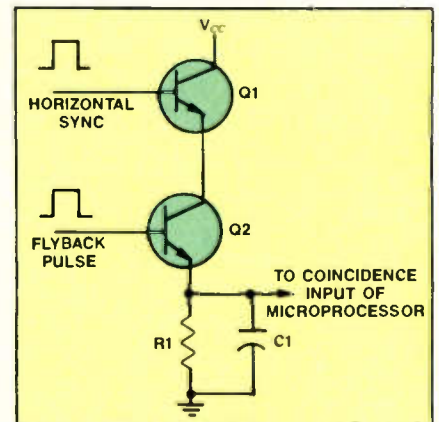
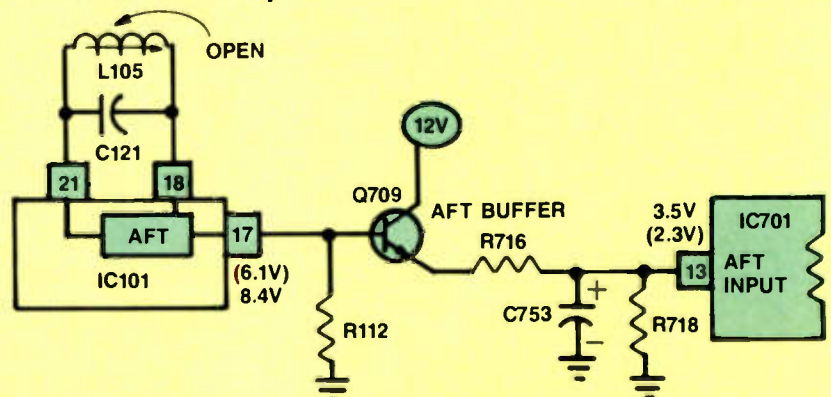

Figure 9. Some receivers use an external circuit to convert the valid sync signal from an ac signal to a dc logic level before inputting this signal into the microprocessor. One method is to compare a sync signal and a flyback pulse in an AND circuit.

Case History #4

A GE8-1445 exhibited slow channel lockup in the direct-access mode. In the channel-scan mode, the set would continually search through all the channels. These symptoms seemed to indicate a problem with the AFT input to the microprocessor, IC701. The AFT input, pin 13, was a constant 3.5Vdc and did not change during tuning. Following the AFT line back to IC101, I found that the voltage on pin 17 was both constant and incorrect. (See Figure C.) Before replacing IC101, I decided to check the various discrete components connected to the AFT pins of IC101. This proved to be a good idea because the AFT tank coil, L105, was open. Replacing this coil repaired the set. In this case, the symptoms indicated a tuning problem, yet the defective component was back in the IF section of the chassis.



NOTE: VOLTAGES SHOWN IN PARENTHESES ARE THE NORMAL VALUES. VOLTAGES NOT IN PARENTHESES ARE FROM THE DEFECTIVE RECEIVER.

Figure C. A set that continually searches through all the channels when it is in channel-scan mode might have a tuning problem or it might have a defective component in the IF section. Before assuming that the problem is the AFT input to the IC, check the discrete components connected to the AFT pins.

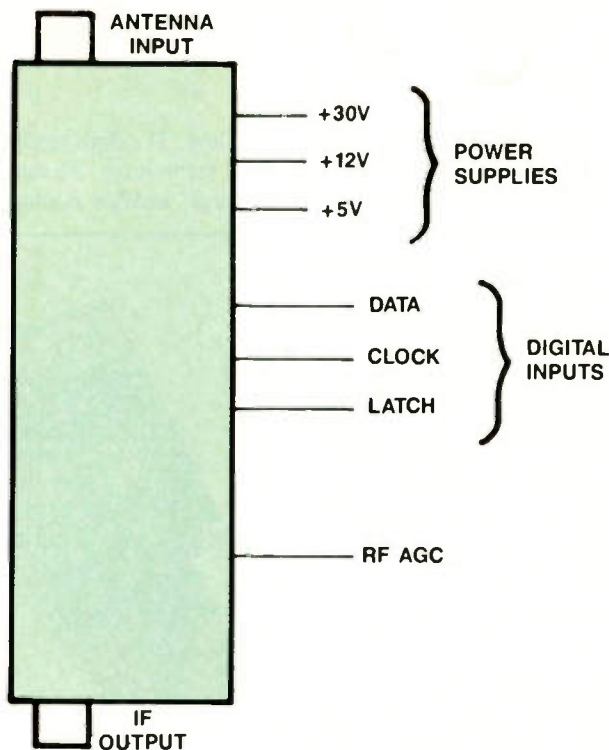

Figure 10. The latest generation of tuning systems place the PLL and bandswitching circuitry inside the tuner. Digital data is sent from the microprocessor right into the tuner. This data instructs the tuner as to the specific channel requested.

ry to maintain proper tuning. When viewing these pins on an oscilloscope, you should see a momentary burst of activity each time a new channel is requested. Offset carrier-search operations are still carried out by the microprocessor. During an offset carrier search, the microprocessor will alter the serial data information, depending on the AFT signal received from the IF section.

After the offset carrier search is completed, the AFT terminal is ignored until the next channel change on most receivers. Because modern transmitters are extremely stable and drift-free, AFT is not required after the search procedure has located the picture carrier. The PLL tuning loop alone will maintain the local oscillator at the correct frequency for proper reception.

However, reception problems in these tuning systems can occur when the viewer selects between multiple RF sources at the same frequency. For example, assume the customer has a cable converter box and a video game attached to the same receiver via an RF switch. If both devices transmit on the same frequency, tuning problems can result. If the customer initially plays a video game before switching to the cable

converter box, the cable box signal could be mistuned. This mistuning is caused by the cable's picture carrier being offset with respect to the video game's picture carrier. Because no channel change was initiated, the AFT terminal is ignored and the receiver produces a mistuned picture. This quirk has caused numerous complaints of intermittent mistuning. When the problem arises, the customer should re-enter the present channel number. An offset carrier search will be performed and proper reception will be restored.

Finally, check the RF AGC input. This tuner input adjusts the gain of the RF amp to maintain a constant signal strength at the output of the IF section. In most tuners, the RF gain is directly proportional to the RF AGC voltage. Troubleshooting methods for the AGC terminal can be found in Part I of this series.

If all inputs to the tuner are present and correct, the tuner itself is defective. Service literature usually does not supply diagrams or parts lists for the tuner, so it must be replaced as an assembly.

Applying these troubleshooting steps should help you repair those mysterious tuning systems. ■

Genuine Replacement Parts

We stock:
**FISHER, GE, PANASONIC
 QUASAR, RCA, SANYO
 SHARP, TECHNICS**

We also carry:
 Original transistors & ICs, belts, flybacks, modules, video heads, video accessories, cables, fuses, chemicals, antennas, styli, resistors, capacitors, telephone accessories, VCR parts, tires, lamps, tools, auto alarms, auto accessories, test equipments and many other parts
CALL FOR FREE CATALOG

**ELECTRONIC PARTS SUPPLY
 4071 EMERY STREET
 EMERYVILLE, CA 94608
 TOLL FREE ORDER DESK
 In Calif: 800-628-9664
 Outside Calif: 800-227-0104
 Information: 415-420-1040**

Circle (18) on Reply Card

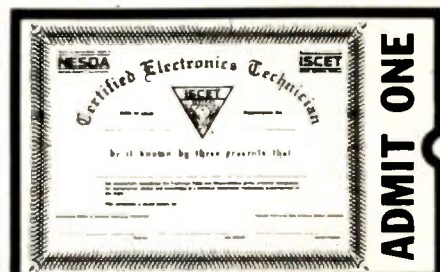

Your Ticket To SUCCESS

Over 25,000 technicians have gained admittance worldwide as certified professionals. Let your ticket start opening doors for you.

ISCET offers Journeyman certification in Consumer Electronics, Industrial, Medical, Communications, MATV, Radar, Computer, and Video. For more information, contact the International Society of Certified Electronics Technicians, 2708 West Berry St., Fort Worth, TX 76109 • (817) 921-9101.

Name _____
 Address _____
 City _____
 State _____ Zip _____

Send material about ISCET and becoming certified.

Send one "Study Guide for the Associate Level CET Test." Enclosed is \$10 (Includes postage).

Frequency converter/modulator

The *B&K Precision* model 120ISR TV frequency converter/modulator converts the output of video pattern generators to operate on any VHF broadcast TV channel, cable TV channel and several



UHF broadcast TV channels. Servicers can use the device to duplicate the cable TV scheme used by service customers without having cable wired into the shop. The unit allows servicers to test all channel tuners and channel assignments for cable-ready TV receivers and VCRs. With an external amplifier, the unit can feed a VCR or other video source into CCTV or MATV systems on any channel. Crystal control and PLL techniques assure that the selected channel operates at the precise frequency, allowing the unit to serve as a frequency standard for tuner testing.

Circle (79) on Reply Card

Ruggedized DMM

American Reliance has introduced the AR-3200, a 4,000-count, programmable, auto-ranging DMM with 0.25% basic accuracy. The ruggedized DMM has an audible range alert that allows it to be used as a level comparator. Features include a relative mode, a programmable TTL/CMOS logic probe (up to 10MHz), a 40-segment analog bargraph display for monitoring peaking and nulling, and min/max memory. A fast display mode provides updated displays 20 times per second. The dBm/dB measurement mode is accurate to within ± 0.3 dB at 60 dB. Measurements include dcV, ac and dBm, ac and dc current, audible continuity, diode test and resistance. Measurement ranges are 400mVdc to 1,000Vdc, 4Vac to 750Vac, 400 μ A to 20A ac or dc, and 400 Ω to 40M Ω .

Circle (80) on Reply Card

Signal generator

The model 408 gen-lockable NTSC

video test signal generator from *Leader Instruments* provides more than 80 test patterns in composite, S-VHS, RGB and Y, R-Y B-Y output formats with RF channel coverage of all broadcast and cable channels. Channel frequencies and video signal-level specifications are set up using a menu-driven, multi-purpose data control panel with LCD readout. Control of key video signal levels such as sync, burst, luminance, chrominance, setup and RF frequency selection is provided. Up to 100 sets of video level specifications and channel frequencies can be stored in memory for instant recall.

Circle (81) on Reply Card

Electroplating pens

Disposable electroplating pens from *Hunter Products* permit plating without the preparation of plating solutions. The pens are used with a 12V battery and rheostat or variable-voltage dc power supply. The pens are available with copper, tin, zinc, nickel, black nickel, silver, chrome-color, 24K or 18K gold and rhodium.

Circle (82) on Reply Card

Socket bit sets

The Socket Saver interchangeable socket bit sets from *Bondhus* include 26 interchangeable socket bit tools to use with two standard 1/4-inch and 3/8-inch square drive tools. Four sets are available with different bit combinations.

Circle (83) on Reply Card

Video alignment generator

The portable video alignment generator from *Heath* produces a series of crosshatch or dot video patterns to use for converging the red, blue and green video information in a TV set. The unit works off of a 9V battery and includes CMOS circuitry for low power consumption and long battery life. A channel 3 RF output, a choice of six alignment patterns and an NTSC-compatible output for monitor alignment are included.

Circle (84) on Reply Card

Hand-held DMMs

The SOAR models 3210, 3220 and 3230 hand-held DMMs from *Carlo Gavazzi Instruments* feature 3,200-count, full-scale LCD analog bar graph

displays, 3 1/2-digit readout and LSI circuit technology. Features include auto-range, audible continuity and diode



testing. The model 3210 offers 0.7% accuracy and 10A current measurements; the model 3220 offers 0.5% accuracy with 3mA to 10mA ac/dc current measurements; the model 3230 offers 0.35% accuracy with measurements of 300 μ A to 10A ac/dc current ranges.

Circle (85) on Reply Card

Service management software

MAGIC Solutions has introduced the ServiceMagic 1.6 service management software, which maintains inventory and parts usage, service contracts and customer histories; creates work orders and return merchandise authorizations; and tracks shipping and receiving orders in a single module. The 1.6 version also has cross-shipping, mail-in and a receiving module that interfaces directly with work orders.

Circle (86) on Reply Card

Frequency source

The WAVEBOX 100 synthesized frequency source from *Teledata Systems* has 0.001% accuracy and stability over its 1Hz to 100kHz frequency range. The output frequency is dialed directly on thumbwheel switches, and resolution is 1Hz over the entire range. Sine-wave output is variable up to 20V_{p-p} with ± 10 V offset. Total harmonic and non-harmonic distortion is approximately 40dB. Auxiliary TTL/HCMOS level square-wave output is provided.

Circle (87) on Reply Card

HOW TO SUCCEED IN SERVICE

1. Send in this coupon for free information

NAME _____

TITLE _____

COMPANY _____

ADDRESS _____

CITY, STATE, ZIP _____

PHONE _____

Return to: NARDA/NASD Convention & Expo '90
William T. Glasgow, Inc.
16066 South Park Avenue
South Holland, IL 60473

02

2. Go to Nashville for "Success Strategies for the 90's" March 11-14

Here's What You'll Learn

- New management techniques for tough times
- How to avoid getting ripped-off by employees and customers
- How to make your service operation look outstanding to your customer
- How to create new business with effective direct mail advertising
- How to keep good employees
- How to run a healthy service business

Meet successful servicers and

- See hundreds of the most effective ads of 1989
- How to beat the competition with premium service.
- Learn how they solved family business problems
- Find out their most effective expense control measures

Meet with manufacturers of the products you service

- See over a hundred exhibits of brands you service, brands you want to service and products you need to do business
- Meet behind closed doors with the top executives of the brands you service

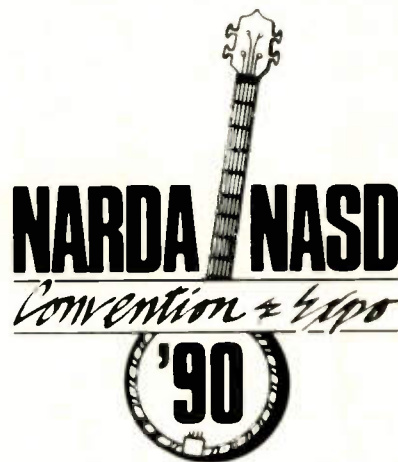

March 11-14, 1990

**OPRYLAND HOTEL
NASHVILLE, TENNESSEE**

For more information call William T. Glasgow, Inc. at 312/333-9292 or fax 312/333-4086.

Sponsored by: NARDA — National Association of Retail Dealers of America and NASD — National Association of Service Dealers

What do you know about electronics?

Truth tables

By Sam Wilson, CET

One of the methods used to evaluate logic gates and circuits is to list all of the possibilities in a truth table. This series has been a review of that method.

EXCLUSIVE OR

The Boolean method of writing EXCLUSIVE OR is $\bar{A}B + A\bar{B} = L$. This equation is read: NOT A AND B OR A AND NOT B equals L.

The Boolean expression tells you how to make an EXCLUSIVE OR using the basic gates. The construction is shown in Figure 1. The first step is to list the inputs. Then, invert the inputs to get the NOT A and NOT B columns. (See Table 1.) When you have A and B columns as well as \bar{A} and \bar{B} columns, you have all of the inputs to the AND gates.

The AND gate marked X in Figure 1 shows that the first and fourth columns in Table 1 must be ANDed — that is,

Wilson is the electronics theory consultant for ES&T.

A	B	\bar{A}	\bar{B}	$\bar{A}B$	$A\bar{B}$	L
0	0	1	1	0	0	0
0	1	1	0	1	0	1
1	0	0	1	0	1	1
1	1	0	0	0	0	0

combined according to AND rules. The only way to get a logic 1 output from an AND gate is to have a logic 1 at each of the inputs. Therefore, the first and fourth columns in the truth table are ANDed. For the AND gate marked Y in Figure 1, the second and third columns of the truth table are ANDed.

The two columns marked $\bar{A}B$ and $A\bar{B}$ are ORed in Table 1 to get the output of the OR gate marked Z. That output — called L — is the desired result. The truth table is redrawn using the first, second and last columns. (See Table 2.) It is the EXCLUSIVE OR truth table.

A	B	L
0	0	0
0	1	1
1	0	1
1	1	0

You can use this same technique to analyze any logic system. When the fan-in (number of inputs) is high, the truth table becomes complicated. (But then, so does the Boolean algebra.) It is sometimes best to divide the circuit into smaller segments and perform the analysis.

Breaking the IC logic codes

The coding of IC logic devices is getting complicated. Here is a brief look at some of the most popular logic ICs:

- 74XX — 7400 series TTL.
- 54/74CXX — CMOS that has the same pinout as a 54XX or 74XX. Example: 74C00 is like a 7400, but it's made with CMOS.
- 54/74SXX — Schottky; same as 54/74XX but faster.
- 54/74LSXX — low-power Schottky; same as 54/74XX series with Schottky, but especially designed for low power.
- 54/74ALSXX — advanced low-power Schottky.
- 54/74FXX — fast TTL.
- 54/74CTXX — CMOS drop-in replacement for 54/74LSXX.
- 4XXX — 4000 series CMOS.
- 54/74HCXXX — unbuffered CMOS, equivalent to TTL.
- QMOS family — high-speed, low-power RCA CMOS devices.
- QMOS HC & HCT — CMOS devices that can be operated with power supplies

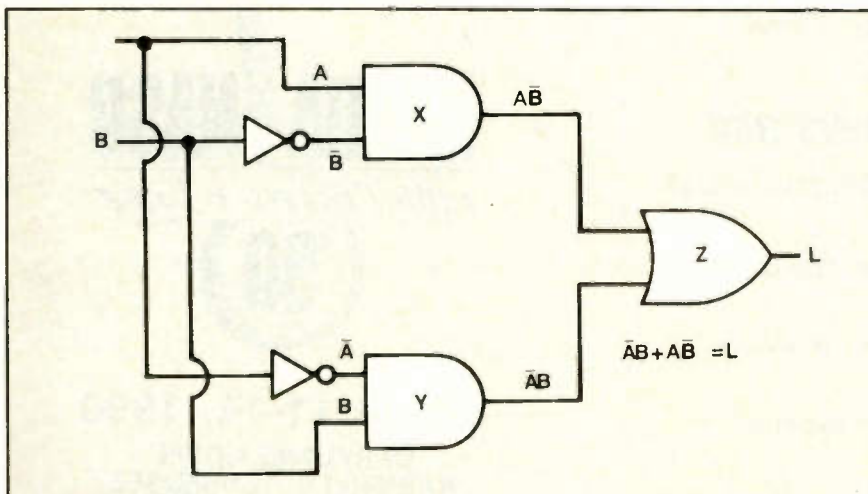

Figure 1. The Boolean $\bar{A}B + A\bar{B} = L$ expression tells you how to make an EXCLUSIVE OR using the basic gates.

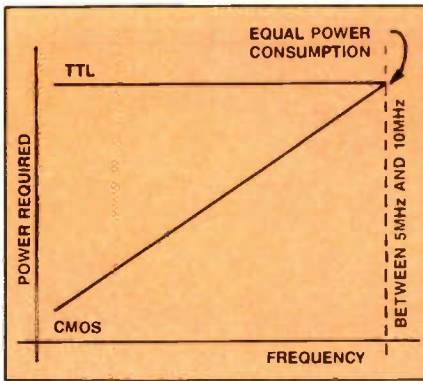

Figure 2. CMOS devices require very little power at low frequencies. At some frequency between 5MHz and 10MHz, the power consumption of CMOS and TTL devices is about the same.

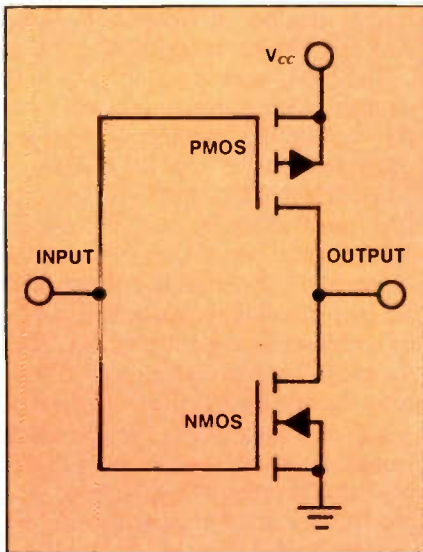

Figure 3. To make an amplifier out of an inverter, you should use an unbuffered CMOS device. A CMOS inverter is made with complementary MOSFETS.

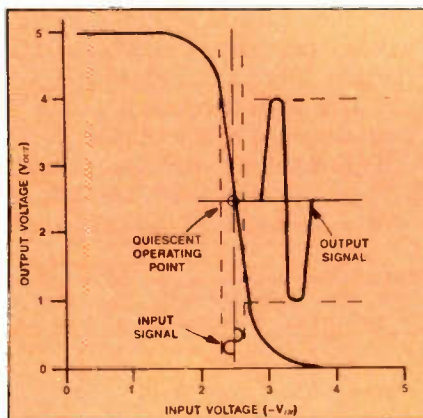

Figure 4. To make an amplifier out of an inverter, you should use an unbuffered CMOS device such as the 54/74HCU04 hex inverter, which has these transfer characteristics.

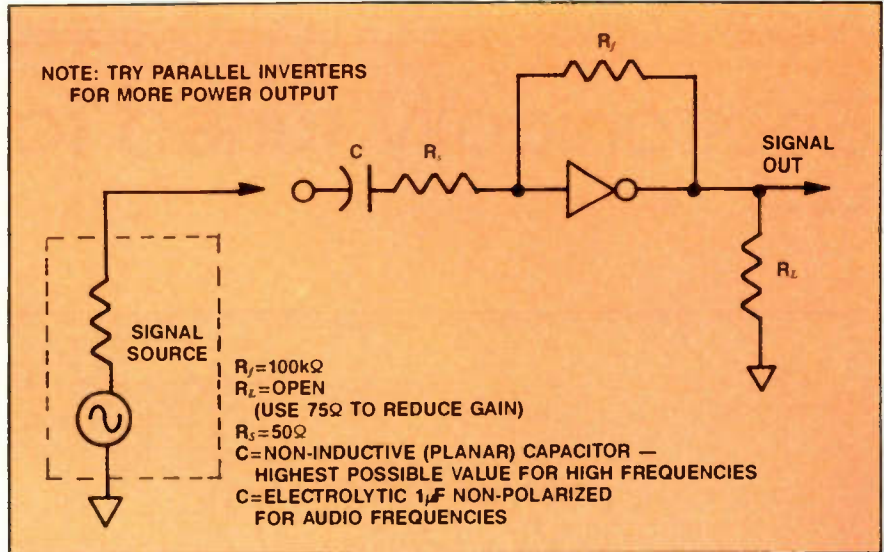

Figure 5. For an amplifier made from an inverter, use +2.5V and -2.5V supplies (split a 5V floating supply). The amp should have a gain of about 10 with low noise and will handle frequencies up to about 6MHz.

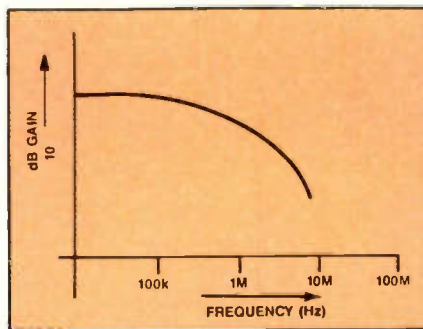

Figure 6. A typical response curve for the amplifier.

in the range of 2 to 6V (7V max).

You usually think of TTL as being faster and CMOS as being more efficient. However, that generalization is not exactly true. At high frequencies (in the megahertz range), the TTL logic is more efficient than CMOS. Of course, if speed is important, the designer should consider ECL.

CMOS has a bad reputation for being destroyed by static charges. However, the newer CMOS are buffered — that is, protected against static destruction.

Despite a manufacturer's claim that a logic gate from one certain family can be directly substituted for a gate from another family, remember that different propagation delays can cause destructive glitches. Use identical replacement whenever you can.

Another factor is power consumption. A system supply designed for lower power may not be able to provide the higher power required from a logic family that demands more power.

Figure 2 shows a graph of power con-

sumption vs. frequency. You can see that CMOS devices require very little power at low frequencies. At some frequency between 5MHz and 10MHz, the power consumption is about the same.

TTL devices require power to be delivered from the signal source. CMOS requires no signal power (current). You cannot interchange 7400 and 4000 series logic gates for that reason alone.

The 21 cent amplifier — updated

A long, long time ago I wrote an article about an amplifier that cost 21 cents. It involved the use of a CMOS inverter, which is made with complementary MOSFETS as shown in Figure 3.

I wasn't surprised to see an RCA applications note on using a CMOS inverter as an amplifier. Since it was published, RCA was taken over by GE. The semiconductor division was then taken over by Harris. At least, that's the way it was told to me by someone working at Harris.

To make an amplifier out of an inverter, you should use an unbuffered CMOS device. The 54/74HCU04 hex inverter is a good choice, according to the RCA manual. Figure 4 shows its transfer characteristics. Figure 5 shows the amplifier. Use +2.5V and -2.5V supplies. You can get those voltages from splitting a 5V floating supply. With the values shown, you should get a gain of about 10 and with low noise. It will handle frequencies up to about 6MHz. Figure 6 shows a typical response curve.

How's that for an AM radio pre-amplifier? ■

Electronically tuned radios

By Craig R. Seelig

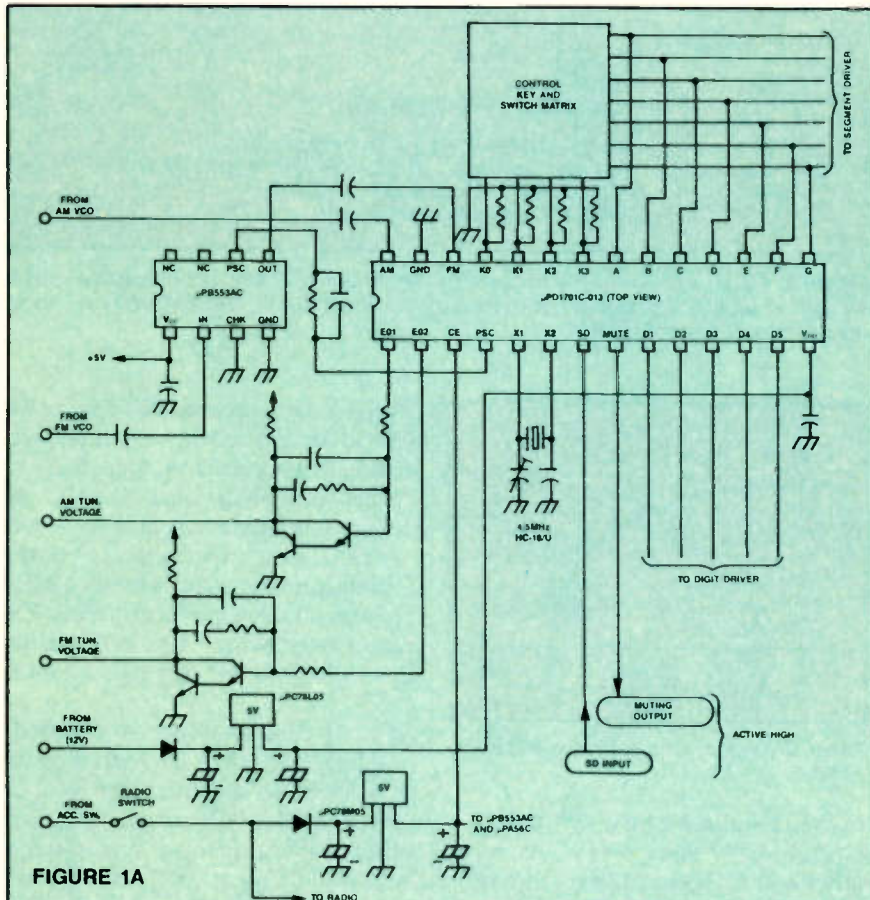

FIGURE 1A

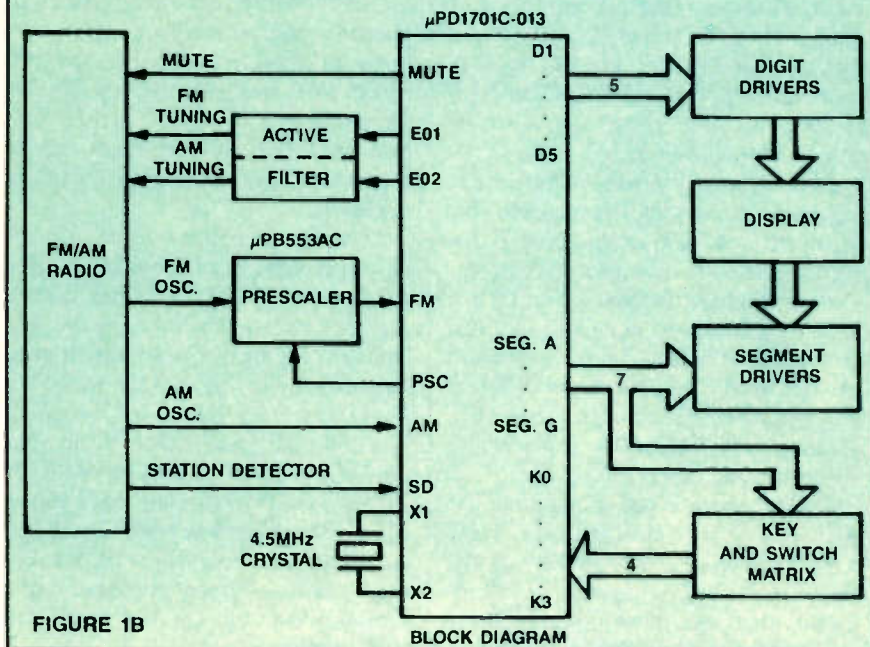

FIGURE 1B

BLOCK DIAGRAM

Electronically tuned radios (ETRs) now compose a major portion of the home and car stereo equipment presently being sold in the United States. An ETR is not to be confused with mechanically tuned radios that employ a frequency counter and digital display instead of a dial scale, mimicking the appearance of an ETR. Such a radio is an analog receiver that will tune to an infinite number of frequencies in the AM and FM broadcast bands.

The ETR, however, tunes to a finite number of valid broadcast channels. In the case of U.S. receivers, these frequencies are from 87.9MHz to 107.9MHz in 200kHz increments in the FM band, 530kHz to 1,620kHz in 10kHz increments in the AM band. Because the FCC demands that broadcast stations maintain tight carrier frequency drift limits, a receiver doesn't need to tune frequencies other than assigned broadcast channels.

Rather than use a mechanically ganged variable capacitor or slug tuner, an ETR tunes by applying a variable tuning voltage to ganged varactors. A phase-locked loop (PLL) is employed to control this tuning voltage. Stability is achieved by using a crystal-controlled reference frequency. From the individual AM and FM local oscillators, a sample is routed to the microprocessor control IC. The control IC uses this sample RF, after processing, to determine whether the tuning voltage should be changed. This process of sampling and adjusting is performed thousands of times a second by the control IC.

ETRs manifest several outstanding advantages over traditionally tuned radios. Mechanical backlash, thermal and me-

Seelig, an electronics servicing consultant, has spent the last 11 years doing circuit-design, prototyping and troubleshooting for a car stereo manufacturing company.

Figure 1. In an electronically tuned radio, a microprocessor selects from a finite number of assigned radio channels. The tuning circuitry of a typical electronically tuned radio is shown here in schematic and block diagram form.

chanical drift, and inaccurate dial scales are all eliminated. Receiver stability is such that ETRs make it possible to receive AM stereo. Of course, all functions are controlled by the touch of a finger. ETRs are also easily aligned.

A common IC

A common electronic tuning system control IC found in both home and car stereo equipment is NEC's PD1701C-013. NEC's application circuit reveals a compact design that is a far cry from the sprawling circuits of early CB radio PLLs and is much easier to troubleshoot and align.

Let's consider some of the specifics.

(See Figure 1.) Two 5V supply connections are required. Pin 14, labeled V_{DD} , is the primary supply for the chip and is constantly powered to maintain memory. Pin 3 is the standby/enable pin. Connected between pins 5 and 6 is a 4.5MHz crystal as required for the on-board oscillator circuit. Pin 1 or 2 supplies low-level control voltage to an external 2-transistor charge-pump/low-pass filter.

Pin 28 directly accepts a sample of the AM local oscillator RF for reference. However, the sample FM local oscillator RF is first divided by the PB533 prescaler IC. This IC is a divide-by-16/17 swallow counter. The resultant,

which is in the range of 6.15MHz to 7.4MHz, is then supplied to pin 26.

When a broadcast signal of sufficient strength is detected by the AM or FM detectors, a logic high is sent to pin 7, which is the station detector input. This information allows the control IC to know when it has scanned up to an occupied channel. While the control IC is scanning, directly accessing a memory preset location or changing bands, pin 8 supplies a logic high to activate external audio muting circuitry.

Next month's Audio Corner will describe user interface functions and give some tips on troubleshooting electronically tuned radios. ■

LEARN VCR

CLEANING/MAINTENANCE/REPAIR

EARN UP TO \$1000 A WEEK, WORKING PART TIME FROM YOUR OWN HOME!



Secrets Revealed!

NO Special Tools or Equipment Needed.

EARN UP TO \$60 AN HOUR AND MORE!

THE MONEYMAKING OPPORTUNITY OF THE 1990's

IF you are able to work with common small hand tools, and are familiar with basic electronics (i.e. able to use voltmeter, understand DC electronics)...

IF you possess average mechanical ability, and have a VCR on which to practice and learn...then we can teach YOU VCR maintenance and repair!

FACT: up to 90% of ALL VCR malfunctions are due to simple MECHANICAL or ELECTRO-MECHANICAL breakdowns!

FACT: over 77 million VCRs in use today nationwide! Average VCR needs service or repair every 12 to 18 months!

Viejo's 400 PAGE TRAINING MANUAL (over 500 photos and illustrations) and AWARD-WINNING VIDEO TRAINING TAPE reveals the SECRETS of VCR maintenance and repair - "real-world" information that is NOT available elsewhere!

Also includes all the info you'll need regarding the BUSINESS-SIDE of running a successful service operation!

FREE INFORMATION

CALL TOLL-FREE 1-800-537-0589
Or write to Viejo Publications, Inc.
3540 Wilshire Bl., STE 310
Los Angeles, CA 90010, Dept. EST

Circle (19) on Reply Card

ATTENTION TECHNICIANS

- ★ JOB OPENINGS
- ★ MONTHLY TECHNICAL TRAINING PROGRAM
- ★ BUSINESS MANAGEMENT TRAINING
- ★ SDC SATELLITE NEWS
- ★ CERTIFICATION
- ★ TECHNICAL SEMINARS

All of this in a nonprofit international association for technicians

FIND OUT MORE:



604 N. Jackson St.
Greencastle, IN 46135
1-800-359-6706

PRIME ELECTRONICS CO.

For All Your Electronic
Parts & Accessories

WE'RE THE ONE . . .

- With over 10,000 Electronic Products
- With Everyday LOW Prices and Volume Discounts
- With 100% Guarantee On All Products
- With the PRB LINE of Replacement Belts and Tires

For Your Free Copy of Our
New Catalog Call Toll-Free
1-800-558-9572

In Wisconsin 1-800-242-9553
or for 24 Hour Ordering Call . . .
FAX: 414-473-4727



"First in Quality And Service"

PRIME ELECTRONICS CO.

P. O. Box 28
Whitewater, Wisconsin 53190

Circle (20) on Reply Card

Understanding the vacuum fluorescent display – Part III

By Stephen J. Miller

In the October and November 1989 issues, we discussed how key-scan and IC time sharing operate the grids and segments of fluorescent display systems. In this issue, we will conclude our analysis of display circuits and provide some case histories and troubleshooting procedures.

Cathode bias schemes

In the November issue, we left off with a description of the two cathode bias schemes. The tube's cathode bias is critical to ensure bright illumination during conduction and no illumination during cutoff. Figure 1A illustrates a cathode bias scheme for negative drive voltage systems. Figure 1B shows a cathode bias scheme for positive drive voltage systems.

In the negative drive system, the cathode is maintained at a dc voltage equal to the negative supply voltage minus the zener's breakover voltage. A typical sup-

ply voltage is $-30V$; a typical zener value is $6V$. Therefore, the cathode is maintained at $-24V$. When the grid driver is off, the grid will be at $-30V$ and a net cathode-to-grid bias of $-6V$ will result, cutting off the tube. When the grid driver transistor is on, the grid will be at $+5V$ and a net cathode-to-grid bias of $+29V$ will bias the tube into conduction. The segment terminals will be similarly affected.

In the positive voltage drive system, the cathode is maintained at a voltage equal to the zener's breakover voltage. Again, $6V$ is a typical zener value. When the grid driver transistor is off, the grid will be at ground potential and a net cathode-to-grid bias of $-6V$ will cut off the tube. When the grid driver transistor is on, the grid will be at $+30V$ and a net cathode-to-grid bias of $+24V$ will bias the tube into conduction. Likewise, the segment terminals will be similarly affected.

The filament or heater terminals of the display tube are usually powered by a separate transformer winding. Because

the filament also acts as the cathode, the cathode bias voltage must be coupled into the filament circuit. Figure 2 gives two examples. In Figure 2A, a center-tapped filament winding is used and the cathode bias voltage is connected to the center tap. In systems that do not use a center-tapped filament winding, two low-value resistors are used as in Figure 2B to couple the cathode bias voltage to the filament circuit. The cathode bias voltage must remain constant across the entire filament. If one side of the filament has a higher cathode bias than the other, the display tube will exhibit unequal illumination. To prevent this type of illumination problem, either a center-tapped winding or twin coupling resistors are used.

Troubleshooting display problems

In troubleshooting display problems, start by checking the power supplies to the driver IC. Next, verify that the cathode bias voltage agrees with the value given in the service manual. This voltage is usually controlled by the zener

Miller is a senior bench technician for a Lancaster, PA, repair company.

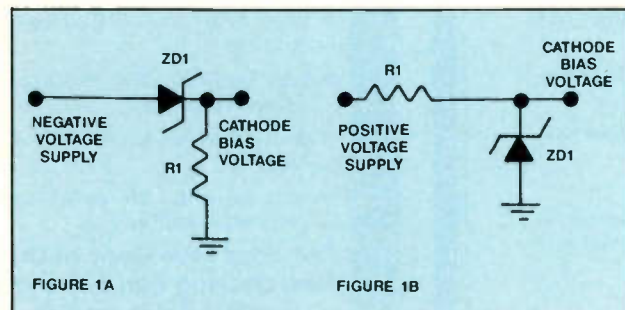
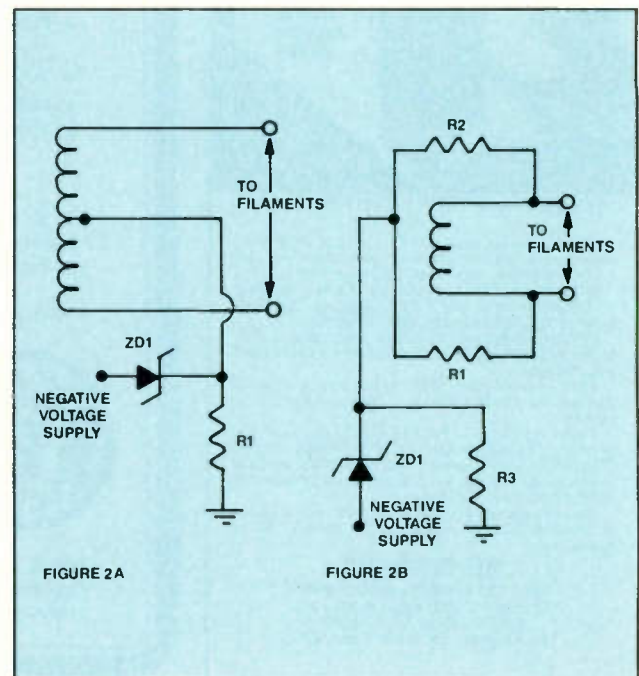

Figure 1. To ensure bright illumination during conduction and no illumination during cutoff, the tube's cathode bias is critical. Figure 1A illustrates a cathode bias scheme for negative drive voltage systems. Figure 1B shows a cathode bias scheme for positive drive voltage systems.

Figure 2. The filament or heater terminals of the display tube are usually powered by a separate transformer winding. Because the filament also acts as the cathode, the cathode bias voltage must be coupled into the filament circuit. If one side of the filament has a higher cathode bias than the other, the display tube will exhibit unequal illumination. To prevent this problem, either a center-tapped winding is used as in Figure 2A, or twin coupling resistors are used as in Figure 2B.



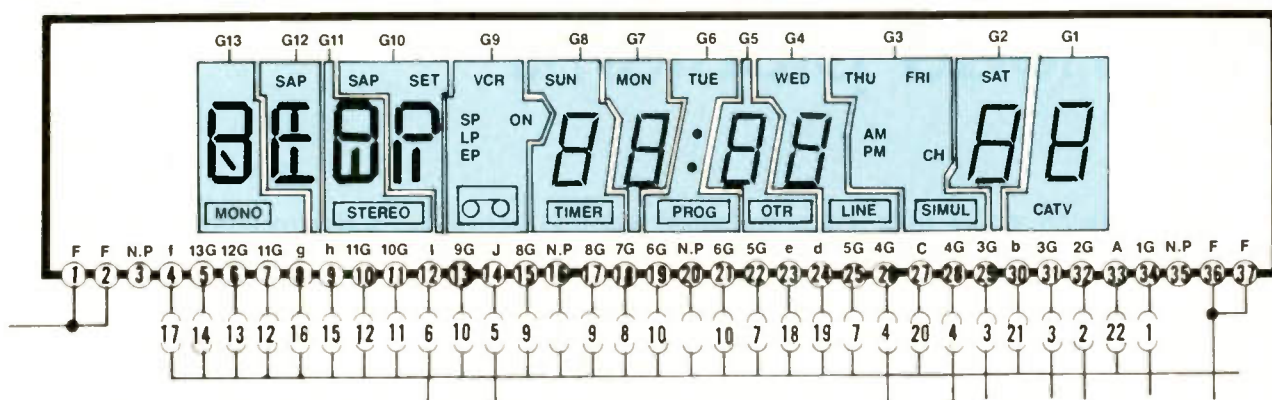

Figure 3. This diagram maps out the grids and segments of a faulty display tube matrix. Because the rest of the display was correct, the problem had to be in the drive signals to grid G4 and G5.

described at the article's beginning.

Leakage in this zener will result in insufficient cutoff of the display, allowing all the segments to glow dimly at all times.

For example, an NEC VCR (model number N925U) was brought in for service with the complaint of an incorrect display. All segments of the display glowed at all times, making the display unreadable. Measuring the cathode bias, I found it to be at $-33V$ instead of $-27V$. D7, the cathode bias zener, exhibited 30Ω of leakage. Often, as in this case, this zener is not located on the timer board but is back on the power-supply regulator board. Replacing this diode restored the VCR to proper operation.

When the VCR's front panel is removed, a silvery black dot will be visible in the corner of most tubes. If this dot appears milky white in color, the tube has lost its vacuum and will not illuminate. Because these tubes are made of glass and are somewhat fragile, take care when working with the VCR's front panel removed.

After verifying both the power-supply inputs and the cathode bias, check the grid and segment drive waveforms. Use dc coupling on your oscilloscope and verify that both the proper peak-to-peak and dc levels are present. These drive pulses are digital signals in that they have only two voltage states: a positive maximum voltage and a negative maximum voltage. The negative voltage supply systems typically will exhibit pulses that extend from $+5V$ to $-30V$. The positive voltage-supply systems will usually exhibit pulses extending from $+30V$ to $0V$ (ground).

If a segment drive signal fails to reach the required maximum positive voltage, that segment will be only dimly illuminated in those grids where it is supposed to be on. When a grid drive signal fails to reach its maximum positive voltage, all the segments that should be on within that grid will be only dimly illuminated.

In an older VCR, the clock sections have been used for much greater lengths of time than the remaining display sections. After sufficient time, these clock sections will become weakened from constant use, and illumination will be dimmer. These VCRs will then exhibit a display with unequal brightness. In these cases, first make sure the grid and segment drive signals are normal. Then, to correct for a few weak sections, the entire display tube must be replaced.

If a segment drive signal fails to reach the required maximum negative voltage, that segment, in all grids, will constantly exhibit dim illumination. When a grid drive signal fails to reach the required maximum negative voltage, all segments within that grid will be dimly illuminated at all times. Leakage within the display driver IC will often prohibit the drive signals from reaching their required maximum negative voltage. Therefore, the major symptom of a leaky driver IC is dim illumination of many erroneous segments. Note that this same symptom can be caused by either a power-supply problem or a cathode bias problem. Don't overlook these possibilities.

Figure 3 shows a diagram that maps out both the grids and segments of a display-tube matrix. Diagrams such as this are generally shown in the service manual. If only part of the display is

working properly, study both the diagram and the VCR display to learn which segments or grids are not functioning normally. Scope these terminals, comparing the waveforms to a properly operating terminal.

Example: A GE VCR (model number VG-7515) arrived for service with the complaint of an incorrect clock display. Although the fluorescent display clock was incorrect, the on-screen display clock was functioning normally. On the fluorescent display, both the tens of minutes and minute sections always displayed the same arrangement of illuminated segments. Figure 3 is the diagram of this display tube. Studying the diagram, I realized that the problem must be in the drive signals to grid G4 and G5 because the rest of the display was correct. Scoping G4 and G5, I found that both had identical drive waveforms with pulse widths that equaled two normal scanning pulses. These incorrect waveforms obviously were causing the symptoms. With both grids on for two scanning pulses, their segments were displaying the sum of both the G4 and G5 data. Resistance measurements indicated 10Ω of leakage between pin 16 (G4 output) and pin 22 (G5 output) of IC701. However, after these pins were isolated from the circuit, no leakage was detected between them. A check of the display tube revealed that the leakage was inside the display tube. Replacing the fluorescent display repaired the VCR.

Fluorescent display circuits are not too difficult. When they are broken down into easily understandable blocks, the circuits can be readily understood and repaired. ■

Print-head problems

Dot matrix printers are the workhorses of computer output. Of course, there are laser printers, but they tend to be on the expensive side for general print output. You can also use formed-character printers, but they tend to be slow and they can't print graphics. Dot matrix printers have several advantages: They can print near-letter-quality characters; they can print acceptable (for many applications) graphics; they're relatively inexpensive to buy and operate; they're fast; and they're reliable. As often as not, if you're called on to service a computer printer, it will be a dot matrix unit.

Printer operation

A dot-matrix printer is a relatively simple device mechanically. The business end of the unit is the print head. This component consists of a housing that contains print wires, which form the dots. These dots make up the character on the page by striking the inked ribbon and forming a dot wherever it strikes the paper. Depending on the character quality desired, dot-matrix print heads may have different numbers of print wires of different diameters. Popular sizes are 9-pin (relatively coarse characters), 21-pin and 24-pin (this size can produce characters that look very much as if they had come off of a good-quality typewriter).

The print head rides on a smoothly polished rail and is driven horizontally across the page by a cogged belt driven by a motor. If everything is working properly, the print head is moved across the page, and when it gets to a point where a portion of a character is to be printed, solenoids in the print head are energized. The solenoids drive the appropriate pins out against the ribbon.

Repair or replace?

The course of action to take when a

print head exhibits problems depends on a number of factors. If the problem can be traced to a cause outside of the print head, it has to be corrected through traditional methods of troubleshooting and repair. On the other hand, if the problem is traced to the print head itself, the only course of action may be to replace the head. In many cases, the print head is a sealed unit and can't be repaired. In most other cases, the cost of purchasing a new print head is more cost-effective than having a professional technician disassemble, clean, lubricate and reassemble the head with no guarantees that the head will work. Even if that seems to help, you have no guarantee whether it will work for a day or for a year. If someone is doing the work for himself as a hobby or to save money, it might make sense to try to repair a print head. Whether a technician should experiment with trying to repair a print head is up to the policy of the shop, but this article will assume that any internal problem in the print head will be most economically repaired by replacement.

Print head symptoms

Here are a few typical symptoms of a faulty print head:

- The print head travels across the page normally, but it doesn't print any characters.
- The print head appears to be printing correctly, but a horizontal line within the line of characters doesn't print.
- The print head appears to be printing correctly, but a horizontal black line runs through the line of characters.
- The print head prints everything correctly, but all of the printing is faint.

If the print head moves but doesn't print, check the wiring. Each of the print head solenoids receives its signal to strike the ribbon from the printer's logic circuitry. The other end of all sole-

noids is connected to a common ground. If the print head travels across the paper without printing, the most likely defect is a disconnected or broken ground wire. If the printer isn't printing, check this wire for continuity first. If this wire is intact, check to see whether there is logic activity in the circuitry that feeds the print wires. If there are signals to the head and the print-head common wire is intact and properly connected, the problem is most likely in the head. Replace it.

If the line of characters has a white line running through it, these are the likely causes:

1. The wiring to the solenoid that controls the motion of that print wire is broken. Check the continuity of that circuit.
2. The solenoid for that print wire may be inoperative or misadjusted. Replace the print head.
3. That print wire may be stuck in. Replace the print head.

If the line of characters has a dark line running through it, check for these likely causes:

1. There is a short in the wiring that feeds the solenoid for that print wire.
2. The print wire may be stuck in the out position. Replace the print head.

If the printer prints everything correctly but the print is light, a number of problems could exist.

1. Check to see whether the ribbon is worn. Replace it if it is.
2. Check to see whether the ribbon is advancing. If not, check the ribbon-advance system.
3. Check to see whether the print head is properly adjusted. Move the print-head adjustment lever to move the print head closer to the paper and try printing out another page. If the adjustment lever is as far as it will go and the printer is still printing light, the problem may be that the print wires are worn out. In this case, replace the print head. ■

Continued from page 37.

ample, the fact that the target of a corporate takeover is a company. But this approach will miss the unexpected, such as the rare but not entirely unknown "Pac-Man defense," in which a target company turns the tables by making a counter-offer to take over its suitor.

In this case, the bottom-up approach, using its knowledge of language, can correct the top-down expectation that a larger company always takes over a smaller one. Similarly, the bottom-up mechanism may be unable to parse a sentence that reveals a takeover to be hostile. The top-down expectation that any takeover is either hostile or friendly enables the system to pick out that crucial fact.

Although other systems contain both types of parsing, only the new GE system gives roughly equal weight to both, thereby exploiting the strengths of each while minimizing their weaknesses. It is this weighting that enables SCISOR to extract important features reliably while ignoring more peripheral background information.

This approach could make SCISOR a powerful tool in applications beyond tracking takeovers. "With the arrival of optical readers, which can feed large amounts of written copy into computers, all businesses will face the problem of overload of their on-line information," said Rau. "The importance of SCISOR is that it can access information in summarized form and essentially in real time; it's better than a library service."

SCISOR also has the potential to help individuals unskilled in computers to gain access to information services that use time-shared mainframe computers (to make airline reservations or seek encyclopedia entries, for example). Scaled-up portions of the SCISOR system could help to extract desired features of an engineering device from a customer's order. In addition to speeding up this device-selection process, automated understanding of customers' specifications could help human engineers produce a more accurate fit to existing equipment. The system could also synthesize information in sales marketing reports from different regions, enabling sales managers to spot trends that might otherwise go unnoticed. ■

Literature

Precision hand tool catalog

Aven International is offering a 16-page catalog describing its precision hand tools, including more than 80 different tweezers of various designs, materials and properties; scissors; forceps; 20 specialized pliers and cutters; mallets; hammers; probes; screwdrivers; and self-illuminated and unilluminated precision magnifiers.

Circle (125) on Reply Card

Electronic and computer parts catalog

American Design Components is offering a catalog of electronic and computer-related parts and components. The 36-page catalog includes components such as integrated circuits, crystals, fans, connectors, semiconductors, batteries, LEDs, switches and power supplies. Computer-related products include disk drives, monitors, add-on boards and complete computers.

Circle (126) on Reply Card

Case catalog

Jensen Tools is offering a catalog of cases and shipping containers. The 32-page catalog includes lightweight and heavy-duty models for computers and peripherals, communications equipment, tools, circuit boards, test equipment and other instrumentation. Vacuum cases, static shielding bags, magnetic-disk portfolios, hand trucks and travel carts are also featured.

Circle (127) on Reply Card

Replacement semiconductor guide

Thomson Consumer Electronics has published its new *SK Replacement Semiconductor Guide* (SKG202F). The guide contains more than 3,370 parts, including 228 recently introduced semiconductors. A 329-page cross-reference section contains references to more than 217,000 original devices. New in the guide are expanded specifications in the discrete devices charts. The SK devices cover a variety of discrete and integrated circuits. Included in the SK line are thyristors, transistors, rectifiers, optoelectronics, microprocessors and other types. Contact a distributor or send \$4 (\$5.30 outside the United States) to TCE Distributor and Special Products Division, P.O. Box 597, Woodbury, NJ 08096. ■

VCR PARTS

SANYO RF Modulator #4-1164-031600	\$17.95 Ea.
FISHER RF Modulator 191002-143-9-4300	17.95 Ea.
MITSUBISHI RF Modulator #PU57855-01	19.95 Ea.
TOSHIBA RF Modulator #MSU-911	19.95 Ea.
RCA Loading Belt 157061 or 157062	10/For 8.50
FISHER Loading Belt 143-2-7504-01000	10/For 8.50
GOLDSTAR Samsung Photo Interrupter	1.99 Ea.
RCA Idler 164113	3.25 Ea.
FISHER Idler 143-0-4204-00400	3.99 Ea.
SHARP Idler NIDL0005	2.99 Ea.
SHARP Idler NIDL0006	2.99 Ea.

POPULAR SEMICONDUCTORS

2SD1341P	Original Sanyo	10 For \$19.90
2SD869	Original Toshiba	10 For 19.90
BU208A	Original Toshiba	10 For 19.90
2SD1398	Original Sanyo	10 For 19.90
STR3115	Original Sanken	3.95 Ea.
STR3125	Original Sanken	3.95 Ea.
STR30120	Original Sanken	3.95 Ea.
STK4273	Original Sanken	(10 min.) 9.95 Ea.
STK0080	Original Sanken	16.95 Ea.
375 Replacement		(10 min.) 99c Ea.

POPULAR CAPACITORS

100MFD/50 Volts	Radial	20 For \$10.00
4.7MFD/250 Volts	Radial	10 For 5.50
10MFD/350 Volts	Radial	10 For 7.50
1000MFD/200 Volts	Snap-In	5 For 12.50
680MFD/200 Volts	Snap-In	5 For 12.50
100MFD/200 Volts	Radial	10 For 12.50
47MFD/50 Volts	Radial	10 For 4.50
10MFD/25 Volts	Non Polarized	10 For 5.00
800MFD/200 Volts	Snap-In	5 For 12.50
80MFD/450 Volts	Axial	10 For 19.50

POPULAR ITEMS

Sharp Flyback	FO009G	\$24.95 Ea.
Sharp Flyback	FO003G	24.95 Ea.
Sharp Flyback	F0014G	24.95 Ea.
Sharp Flyback	F0015G	19.95 Ea.
Sharp Flyback	F0016G	24.95 Ea.
Sanyo Flyback	FO260	14.95 Ea.
Sanyo Flyback	FO192	14.95 Ea.
Tripler	523A/526A	9.95 Ea.
Samsung	FCC1415AL	19.95 Ea.
Samsung	FCC2015AL	19.95 Ea.
Samsung	523/526A	9.95 Ea.

ASK FOR OUR FREE CATALOG!

MAT ELECTRONICS



975 Jaymor Rd.
Southampton, PA 18966

CALL TOLL FREE:

1-800-628-1118

Circle (21) on Reply Card

Collecting those bouncing checks

By William J. Lynott

Do you remember when you took in your first bad check from a customer? I do. Although it was many years ago, I still remember the frustration. I had done my part — repaired a TV set — but the customer paid me with a rubber check. I needed that money, but I didn't know how to go about collecting it. I do now.

One friend of mine, a service dealer for more than 20 years, tells me that he has never received a bad check. Most service dealers I know aren't that lucky. Bad checks pop up often enough in most service businesses to make them decidedly unpopular. Fortunately, there are simple procedures that can sharply reduce the losses and inconveniences those little devils can produce.

Rubber checks

First, it's important to recognize the distinction between a truly "bad" check and one that bounced as the result of a simple error or carelessness on the part of the customer. A check that has been forged or drawn against a non-existent account is obviously the work of someone with criminal intent. When you get hit with a check like that (or one for which the customer stopped payment without good reason), your best bet is to seek legal counsel or help from your local authorities. Fortunately, that sort of situation is relatively rare.

The great majority of returned checks will simply be the result of an insufficient balance in the customer's account. The check usually comes back stamped NSF or "not sufficient funds." If you handle it properly, almost all of these funds can eventually be collected.

In most cases, your best bet when an NSF check is returned is to simply deposit it a second time. Most banks will permit you a second try for NSF checks, and this procedure often allows your

customer time to realize his error and make the necessary deposit to cover the check.

Keep in mind, however, that bank policies vary on this point. Some banks submit NSF checks a second time themselves before they return them to the depositors. Banks using this procedure will usually not allow the depositor to submit the check a second time. If you aren't already familiar with your bank's policy on this point, you may want to check with them.

Once an NSF check has made the round trip twice, you can safely assume you have a problem. What you do next usually will determine whether you're going to collect your money.

Act fast

As unpleasant as the task may seem, you should recognize that it is now time to make a direct contact with the customer. Don't be timid about this step. The customer owes you the money, and you have every moral and ethical right to insist on payment. Be diplomatic in your efforts. As often as not, your customer will be surprised and embarrassed over the incident. Courtesy on your part will help to avoid loss of face for the customer and may save you a valuable customer for the future.

Regardless of the customer's sincerity or lack thereof, a promise for immediate payment will almost always result. It's at this point that many dealers choose to pay a personal call or send a technician to the customer's home or business to collect the money. Human nature has a way of encouraging us to postpone unpleasant duties. The more time that passes after a debt is incurred, the greater the odds that it will never be discharged. This is one case where haste does not make waste, so act quickly.

That first bad check I mentioned came when I was just getting started in the business world. I had done a major overhaul on the customer's TV set — in-

vested what to me was a princely sum in parts. My pay came in the form of a bad check.

I contacted the customer, who was very apologetic. He assured me that a new check would be mailed immediately. I waited patiently for that check. You guessed it — it never came. Young and inexperienced, I didn't know what to do next.

That lesson stuck with me, and you may want to keep it in mind. Strike while the proverbial iron is hot. Ask for your money forthwith. You've earned it; you're entitled to it. You need not be hesitant to insist on payment as long as your collection efforts are carried out with courtesy and tact.

Harassment

A word of caution: Changing legislation has set new ground rules for debtors attempting to collect unpaid debts. You must be careful to avoid any action that could be interpreted as undue harassment in order to stay clear of entanglement with these new laws. Short of that, you should insist on payment of any money that is rightfully due you. Every uncollected check is a drain on your profits. Keeping that in mind may serve to strengthen your resolve.

And don't make the mistake of turning over an uncollected check to the customer before you've been paid. Although you may not press for collection through legal channels, the returned check is the only evidence for your case. *Never*, under any circumstances, part with that check until you've been paid.

Attempts to collect money from recalcitrant customers are not the most pleasant duties for a service dealer. The harsh truth of the matter, however, is that as long as there have been businesses, there have been customers who have been slow or no-pay. Dealing with them in a polite but uncompromising manner is a prime requisite for the servicer who expects to remain in business. ■

Lynott is president of W.J. Lynott, Associates, a management consulting firm specializing in profitable service management and customer satisfaction research.

Readers' Exchange

Readers' Exchange items cost 50 cents per word, per insertion, and must be accompanied by payment to ensure publication.

- Each initial or abbreviation counts as a full word (w/probes would be two words).
- Model numbers count as one word only. Company names also count (ACME model xyz would be three words).
- Specification ranges count as one word (1Hz-3MHz).
- Addresses should be included in the word count.
- Readers' Exchange items will continue to cover only Wanted and For Sale items. Specialized heads, such as job opportunities, business opportunities or help wanted, must continue to run in the Classifieds section.

Send your Readers' Exchange submissions, with check or money order, to:

READERS' EXCHANGE
% Jenny Wittman
Electronic Servicing & Technology
P.O. Box 12901
Overland Park, KS 66212

FOR SALE

Sencore T.V. and VCR test equipment. Bought new in June '89, used very little. VA62, VC63, NT64. ST65, PR57, CR70, LC75. Also, Tektronix 2247A oscilloscope. (707) 823-1103. 11-89 1-T

CB Gen. - \$125.00; SWR Pwr. - \$25.00; C.B. SER Master - \$75.00; 12V supply - \$30.00; X-STR tester - \$40.00; VOM - \$40.00; Tube tester - \$25.00; 10 MHz scope - \$95.00; DVM - \$42.00; Dot Gen. - \$65.00; Capacitance tester - \$125.00; I.C. tester - \$250.00; Deviation meter - \$250.00. **BOULEVARD RADIO & TV SERVICE, 1431 Robinson Avenue, HAVERTOWN, PA 19083, (215) 642-4429** 11-89 2-T

Sencore VA62, 63, 64. Ex231: \$2250. Sencore VA48: \$450. Tentel Tools VHS Package: \$1250; Bob Hendrickson, 5116 Hutchins St., Winston-Salem, N.C. 27106. 919-922-4571. 12-89 2T

RCA Color Test Jig and/or adapters. SASE for list. Box 787, Montrose, CO 81402. 12-89 1-T

B&K 1076 analyst: sweep part works, video part doesn't. Eddie Bryant, 9809 Hilgert Drive, Cleveland, OH 44104. (216) 721-9435. 12-89 1-T

Sams Photofacts and specialized books. All numbers. Loeb, 414 Chestnut Lane, East Meadow, NY 11554-12-89 2-T

WANTED

Wanted: Late complete years of manufacturer volumes of paper or microfiche service manuals for TV and VCR including service hints, service bulletins, and technical training manuals. Also want Bell & Howell MM2000 microfiche reader. (612) 477-4211 day, (612) 497-2709 night. Vergin TV, P.O. Box 220, Rockford, MN 55373 12-89 1-T

Wanted—19" Color Portable General Electric Television. Manufactured in 1970 or 1971 - Must have a C-1 Chassis - State Condition and Price - Contact Joe Rizzo 1-800-523-2900. 12-89 1-T

Need schematic Keyboard KTC 65-0821-01. George Kieffer, 5437 West 140 St., Hawthorne, CA 90250 12-89 1T

Moving?

Take us with you.

Just peel off the subscription mailing label and attach it to the address change card located at the front of this issue. Please allow 6-8 weeks to process your address change.

Classified

Advertising rates in the Classified Section are \$1.65 per word, per insertion, and must be accompanied by payment to insure publication.

Each initial or abbreviation counts as a full word.

Minimum classified charge \$35.00.

For ads on which replies are sent to us for forwarding (blind ads), there is an additional charge of \$40.00 per insertion to cover department number, processing of replies, and mailing costs.

Classified columns are not open to advertising of any products regularly produced by manufacturers unless used and no longer owned by the manufacturer or distributor.

BUSINESS OPPORTUNITIES

SPEAKER REPAIR. 4"-18" Speakers reconed. Cross-over parts. Orban Audio, 119 7th St. NW, North Canton, Ohio 44720, (216) 497-9932 6pm-9pm EST. 4-89-tfn

LARGE AUDIO/VIDEO SERVICE BUSINESS. In sunny S.W. city. Established 20 yrs. Well-equipped. Price & terms negotiable. (602) 298-8827. eves. 8-89-tfn

TV/VCR/TVRO SALES & SERVICE; VHS Video Rental with over 1400 tapes. Service for most area major retailers. State of the art test equipment, inventory, van included. Investment of \$75,000. 703-373-1212 Susan 12-89-11

Use ES&T
classified ads

FOR SALE

VHS-VCR Repair Solutions Sets I, II, III, IV, V. Each contains 150 symptoms and cures, cross reference chart, free assistance, \$11.95 each all five \$49.95. Eagle Electronics, 52053 Locks Lane, Granger, IN 46530 12-89-TFN

PHOTOFACTS: Folders under #1400, \$4.00. Above #1400, \$6.00. Sent same day first-class postpaid. Loeb, 414 Chestnut Lane, East Meadow, NY 11554. 12-89-31

OVER 100 TRADE-IN COLOR TVs, as is condition. 20 lot minimum. Reid's TV, 2510 Crill Avenue, Palatka, FL 32177. 1-904-325-5343. 12-89-11

TV SERVICE SHOP: Beautiful Oregon coast, equip with latest Sencore service equipment. Only service shop in 50 mile radius. Gross 100,000 yearly sales. Priced to sell at \$50,000. Send inquiries to: 2205 10th, Florence, OR 97439. 12-89-11

FLORIDA SUNCOAST TV/VCR/MICROWAVE SHOP High growth area in U.S. Fully equipped. Established Since 1973. Owner Retiring. Day (904) 489-1669, Evening (904) 489-3002. 12-89-11

STOCKLOT 4000 PCS AC/DC ADAPTORS \$2.00. GE Brand. UL listed. Input 120V 60Hz 6W. Output 9V DC 300 mA. Mr. K. S. Seow. ISLAND DISTRIBUTORS PTE LTD., 164 Bukit Merah Central, #03-3649 Singapore 0315. Tel: 2735050 Fax: 2741601 12-89-11

TV TROUBLESHOOTING: Over 300 problems/solutions. Nothing old listed. \$12.00, add \$1.50 shipping. Refund if not satisfied. Jones Enterprises, Box 702, Niceville, FL 32578. 12-89-TFN

VHS-VCR Repair Solutions Sets I, II, III, IV, V. Each contains 150 symptoms and cures, cross reference chart, free assistance, \$11.95 each, all five \$49.95. Eagle Electronic, 52053 Locks Lane, Granger, IN 46530. 10-89-TFN

TV/VCR REPAIR SOLUTIONS, printed out or IBM compatible with hard drive. 2,700 solutions (26 manufacturers). Save hundreds of hours. Quick scan by maker, model, chassis, or stage. \$90. Electronic Solutions, 407 West Avenue "N", San Angelo, Texas 76903 12-89-11

For Sale: TV Sales and Service Business, Real Estate, Tools and Inventory. Good family business, Good cash flow. Contact Whitney Realty Inc., P.O. Box 1947, Bandera, Texas, 78003 (512) 796-4497 12-89-11

TV TOUGH DOGS: 300 symptoms and cures. Send \$8.95 to DAVIS TV, 11772 Old Fashion Way, Garden Grove, CA 92640. 10-87-tfn

REDUCED 75%, Diehl Mark V scanner \$219, Diehl Mark III scanner \$89. New. 2805 University Ave., Madison, Wis. 53705, 608-238-4629, 608-233-9741. 3-89-tfn

HELP WANTED

TV TECHNICIAN. Outside calls. Dealer 33 years. Small N.E. Florida town on St. Johns river. Good fishing and hunting. Low cost of living. Good pay and benefits. Phone 1-904-325-5343 or 904-325-5077 evenings. Ed Reid, Palatka, FL 12-89-11

Just the fax...

Now it's easier than ever to run your ad in Electronic Servicing & Technology's Classified Advertising section. All you need to do is fax your ad and we'll take care of the rest.

Easy, right?

Fax #913/541-6697

Attention: Renee Hambleton,
Classified Ad Mgr.

FIX VCR's

3 out of 4 VCR breakdowns are due to a mechanical problems.
Do you have the tools to find these problems?
TENTEL Does!



Call Toll Free
(800)538-6894
In Calif- (916)939-4005

**4475 Golden Foothill Pkwy
El Dorado Hills, CA 95630**

Circle (22) on Reply Card

"Tech's Guide To Pricing"
updated new 5th edition... a framework for setting rates that apply to Hi-Tech products... a formula that guarantees SUCCESS!
Call Toll Free for details **1-800-228-4338** 8/5 CST

Circle (23) on Reply Card

WHY PAY SENCORE \$1295?
TEST/CLEAN/RESTORE with a UNIVERSAL CRT ADAPTER that fits all CRT testers and quickly hooks-up to all CRT's on the market (now or in the future). Guarantees profit & total CRT servicing. Used by TV Repair, US Govt., Airlines, Computer Serv., Dept. of Defense. Patented Adaptor-Sockets-CRT Reference/Setup book—Only \$59.95 plus \$2.50 postage & handling. Our 6th year. Over 15,000 sold. Chargecards/Checks/COD, Money Back Guarantee.
FREE CALL 1-800-331-9658
DANDY MFG. CO./RANDALL ELECTRONICS
(918) 682-4286, 2323 Gibson St., Muskogee, OK 74403

Circle (24) on Reply Card

IN OUR CONTINUING EFFORTS TO SERVE YOU...

From time to time, Intertec Publishing Corp. makes its subscriber lists available to carefully screened companies or organizations whose products, services, or information may be of interest to you. In every case, list users must submit their promotional material for approval. They may use the list only once.

No information other than name and address is ever divulged, although names may be selected by segments to which the particular offer might appeal.

We are confident that the majority of our readers appreciate this controlled use of mailing lists. A few people may prefer their names not be used.

If you wish to have your name removed from any lists that we make available to others, please send your request, together with your mailing address label to:

**Direct Mail Mgr.
Intertec Publishing Corp.
P.O. Box 12901
Overland Park, KS 66212**

Advertisers' Index

Company	Pages Number	Reader Service Number	Advertiser Hotline
Dandy Mfg. Co.	60	24	800/331-9658
Electronic Parts Supply	47	18	415/420-1040
ETA	53		800/359-6706
Fordham Radio Supply Co.	IBC	2	800/645-9518
Iscet	47		817/921-9101
Kenwood Test & Measuring Instruments	11	11	213/639-4200
Leader Instruments, Corp.	3	8,9	800/645-5104
M.A.T. Electronics	57	21	800/628-1118
Matsushita Services Co. (Parts Div.)	12,13	12	201/348-7589
MCM Electronics	23	26	800/543-4330
NARDA/NASD	49		312/333-9292
Nesda	43,45		817/921-9061
NTE Electronics, Inc.	5	10	800/631-1250
Nutronix Inc.	43	16	313/939-4710
Parts Express Int'l. Inc.	41	15	513/222-0173
Philips ECG	1	4-7	800/225-8326
Prime Electronics	53	20	414/473-4727
PTS Corp	15,17	13,14	800/333-PTSI
Sencore, Inc.	IFC	1	800/843-3338
Sony Service Company	7		201/930-6392
Sperry Tech, Inc.	60	23	800/228-4338
Techni-Tool	23	25	215/825-4990
Tentel	60	22	800/538-6894
Tritronics	39	27	305/938-8030
Viejo Publications	53	19	800/537-0589
Zenith	BAC		

ADVERTISING SALES OFFICES

ELECTRONIC

Service & Technology

KANSAS CITY, MISSOURI
Greg Garrison, Sales Manager
P.O. Box 12901
Overland Park, KS 66212
Phone: (913) 888-4664
Fax: (913) 541-6697
Telex: 42-4156 INTERTEC OLPK

OXFORD, ENGLAND
Nicholas McGeachin
Roseleigh House, New Street
Deddington, Oxford OX5 4SP
Phone: (0869) 38794
Telefax: (0869) 38040
Telex: 837469 BES G

TOKYO, JAPAN
Masuyoshi Yoshikawa
Orient Echo, Inc.
1101 Grand Maison
Shimomiyabi-Cho, 2-18
Shinjuku-ku, Tokyo 162, Japan
Tel: 03-235-5961
Telex: J-33376 MYORIENT

FREWVILLE, SOUTH AUSTRALIA
John Williamson
Hastwell, Williamson, Rep. Pty. Ltd.
109 Conyngham Street
Frewville 5063
South Australia
Phone: (08) 79 9522
Fax: 08 79 9735
Telex: AA87113 HANDM

TROUBLESHOOTERS!

PRECISION HAND-HELD INSTRUMENTS



B & K Precision Test Bench™
 • 41 range voltmeter • Ammeter
 • Ohmmeter • Frequency counter
 • Capacitance meter • Logic probe
 • Transistor & diode tester • Extra large LCD display

Model 388-HD
 Reg. \$129.95 **\$119⁰⁰**



SCOPE Digital Multimeter
 • 11 function, 38 ranges including Logic Level Detector, Audible and Visual Continuity, Capacitance & Conductance measurements

Model DVM-638
 Reg. \$87.50 **\$79⁹⁵**



SCOPE 3 1/2 Digit LCD Mini Meter
 • 0.5% accuracy • AC/DC Voltage
 • DC current • Resistance • Diode test • 300 hrs. battery life
 • Overload protection: DC-500V, AC-350V, ohms - 250V DC/AC

Model DVM-630
 Reg. \$50.00 **\$32⁵⁰**



SCOPE Hand-Held 3 1/2 Digit LCR Meter
 • Measure capacitance, resistance and inductance • Overload protection • Includes test leads, test clips, 9V battery and spare fuse

Model LCR-680
\$119⁹⁵



SCOPE Pocket Size Audio Signal Generator
 • Sine/square wave patterns • 20Hz to 150 KHz • Battery operated
 • Frequency accuracy $\pm 3\%$ (or less)
 • Output 1.2V rms max. (no load)
 • Low battery indicator • Test leads & 9V battery included

Model RC-555
 Reg. \$69.95 **\$59⁹⁵**

DUAL TRACE OSCILLOSCOPES



A.W. SPERRY 20 MHz OSCILLOSCOPE
 • Built-in component checker
 • Z-axis input • Low power consumption • TV Video sync filter • High-sensitivity XY mode
 • Front panel trace rotator
 • Includes 2 test probes

Model 620C
\$349⁹⁵

HITACHI 35 MHz OSCILLOSCOPE
 • 19 calibrated sweeps • 6" CRT with internal graticule, scale illumination & photographic bezel • Auto focus
 • XY operation • TV sync separation • Includes 2 probes (10:1 and 1:1)

Model V-355
 Reg. \$899.95



\$598⁰⁰

TRAINERS AND TOOLS



SCOPE DIGITAL TRAINER
 • Learn logic circuits and equipment design • Connects to oscilloscopes, signal generators and more • Logic probe included • Solderless breadboard and crib sheets help you build almost any circuit
 • Runs off 4 "AA" batteries or AC adapter (included)

Model DT-01
 Reg. \$149.95 **\$110⁰⁰**

ALL PURPOSE 92-PC. TOOL CASE
 • Complete kit for home, workshop and auto • Includes 52 pc. socket set with extenders
 • 2 tool pallets with roomy rear storage compartments
 • Attractive, rugged carry case

Model FTK-28
 Reg. \$169.95

\$129⁹⁵



ASK FOR YOUR FREE CATALOG

Fordham TOLL FREE 800-645-9518

(In NY State 800-832-1446)

260 Motor Parkway
 Hauppauge, New York 11788



Money orders, checks accepted
 C.O.D.'s require 25% deposit.

Service & Shipping Charge Schedule Continental U.S.A.

FOR ORDERS	ADD
\$0-50	\$4.50
\$51-100	\$6.00
\$101-200	\$8.00
\$201-300	\$9.00
\$301-400	\$10.00
\$401-500	\$12.00
\$501-750	\$15.00
\$751-1,000	\$17.50
\$1,001-1,250	\$20.00
\$1,251-1,500	\$25.00
\$1,501-2,000	\$30.00
\$2,001 and up	\$36.00

Circle (2) on Reply Card

PLAY IT SMART!



**INSIST ON
GENUINE ZENITH
FACTORY-FRESH
REPLACEMENT PARTS
NOW AVAILABLE AT
AUTHORIZED
EXCHANGE COUNTERS
THROUGHOUT THE U.S.**

Two of the most important reasons for exchanging Zenith replacement parts through your participating distributor's Exchange Program:

- 1) Your replacement part will most likely contain the latest Zenith engineering updates,
- 2) You will be assured of receiving a factory-fresh replacement part remanufactured and serviced for reliability by Zenith people

as knowledgeable and dedicated as those who made the original.

Don't risk exchanging sophisticated Zenith modules, tuners, channel selectors and sub-assemblies anywhere else.

Write today and we'll help you locate an authorized distributor Exchange Counter near you!

ZENITH
®

The quality goes in before the name goes on.®

Zenith Service, Parts & Accessories/11000 Seymour Avenue/Franklin Park, IL 60131 • A Division of Zenith Electronics Corporation